

Chelsea® 522 Series

Rear Mount Power Take-Off



Overview:

The 522 series P.T.O. is a two gear P.T.O. designed to fit the rear opening featured on the ZF Freedomline™ Transmissions. This P.T.O. is an excellent choice when there is a clearance issue with frame rails and exhaust systems. Installation is very quick and easy and there is no back lash to set. The unit comes standard with a 1-1/4" round output shaft Torque rating up to 258 Lbs. ft. make this a robust choice for your applications.

- Dump Truck
- Aerial
- Snow & Ice Removal
- Bulk Transporters



Product Features and Benefits:

Contact Information:

Parker Hannifin Corporation
Chelsea Products Division
8225 Hacks Cross Road
Olive Branch, MS 38654 USA

Phone: 1-888-PH4-TRUK
(1-888-744-8785)

Fax: 1-662-890-5379
chelseacustserv@parker.com

www.parker/chelsea.com

- Designed for the ZF Freedomline™ transmissions (US)
- ZF, Eaton and Iveco transmissions (EU)
- Direct mount pump flanges available
- Installation is quick and easy
- Comes standard with 1410 Series output flange (US)



ENGINEERING YOUR SUCCESS.

Model Number Designation

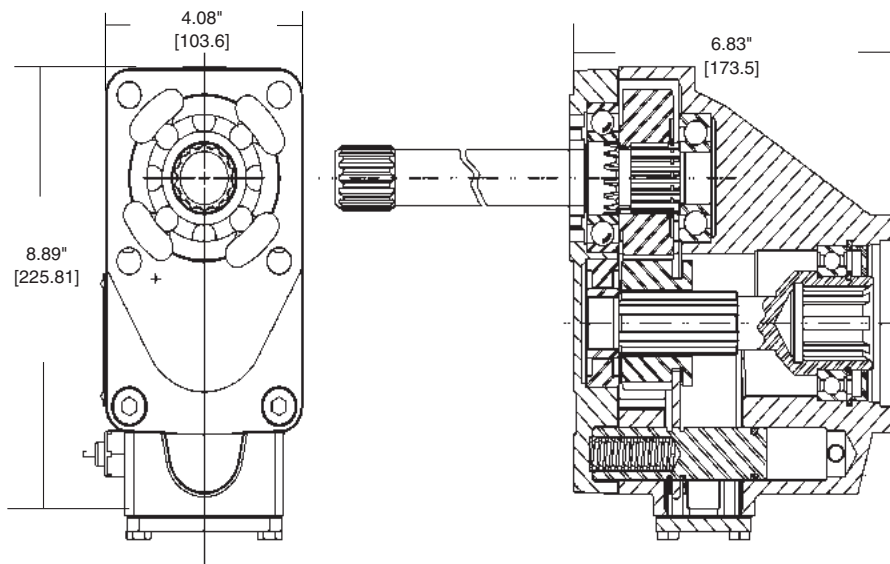
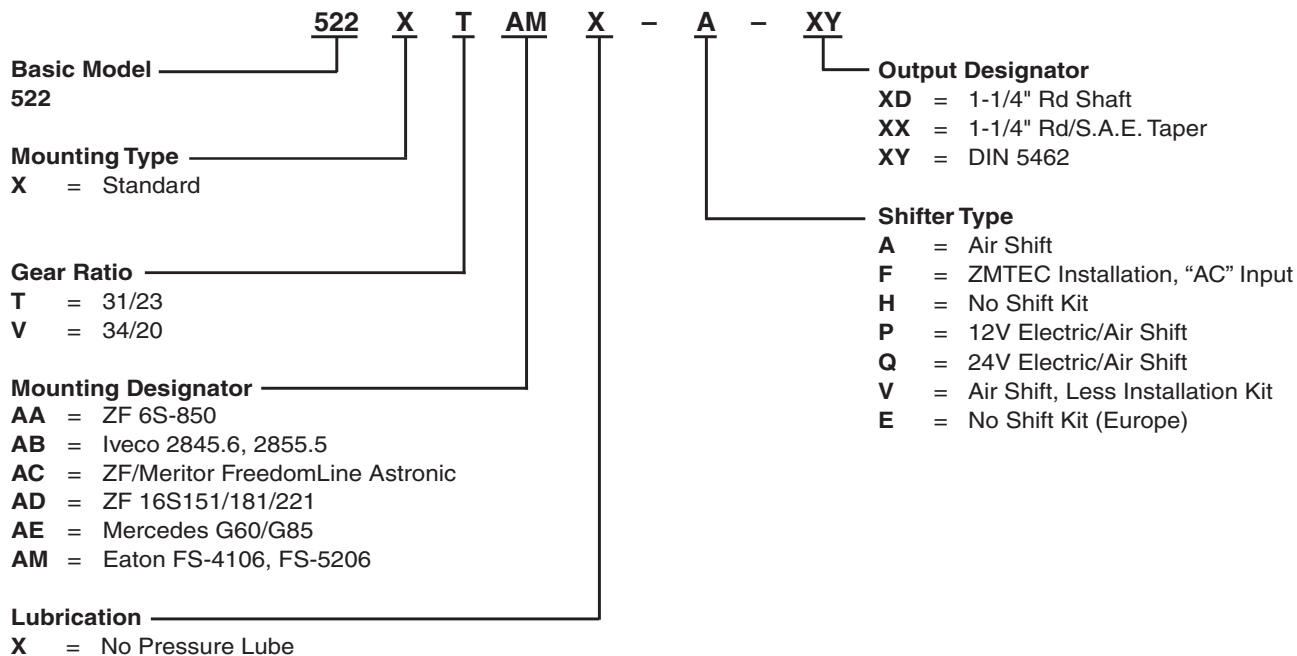

Series Specifications Chart – 522 Series

	522*T	522*V
Standard Output Shaft Size	— 1-1/4" Round w/key —	
Intermittent Torque Rating (Lbs. ft.)	258	258
Intermittent Torque Rating (N.m.)	350	350
Horsepower Rating for Intermittent Service		
At 500 R.P.M. of the Output Shaft (HP)	25	25
At 1000 R.P.M. of the Output Shaft (HP)	49	49
At 500 R.P.M. of the Output Shaft (Kw)	18	18
At 1000 R.P.M. of the Output Shaft (Kw)	37	37
Approximate Weight:	— 35lbs. [16 kg] —	