

Large Size – Engineered Plastics

LS-800PVC Series – Our Most Economical Large Size Unit

- ▶ NSF Approved All-PVC Wetted Parts Available
- ▶ 1 to 7 Actuation Levels
- ▶ Lengths to 60 inches

Inexpensive, all-PVC LS-800PVC Series switches bring reliable level sensing to corrosive liquids. These durable, yet economical, switches use the same high-quality, dependable reed switches found in GEMS' most expensive models. NSF-approved wetted parts make the LS-800PVC suitable for potable water applications.

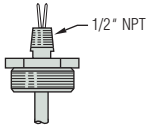
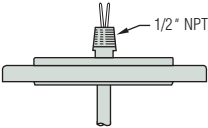

1. Mounting Types

	Type 1 1/2" NPT	Type 3 2" NPT	Type 4 3", 150# Flange
			
Mounting and All Wetted Parts	PVC		
Operating Temperatures	0°F to 125°F (-17.8°C to 51.7°C)		
Pressure, PSI, Max.	15 @ 70°F (21°C)		
Max. Length (Lo)	60 inches (152.4cm)		
Mounting Position	Vertical ±30° Inclination		

2. Float Type

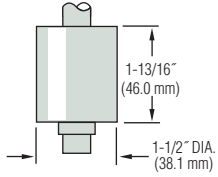
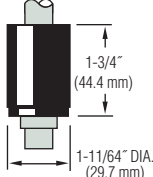
Float Material	PVC*	Buna N
Float Dimensions		
Float Part Number	16306	142251
Min. Liquid Specific Gravity	0.85	0.80

*Select for potable water applications.

LS-800PVC Series – Continued

3. Number of Actuation Levels and Electrical Specifications

Typically, one float is required for each point at which you need a switch action to occur. The number of actuation levels available depends on type of wiring selected. See below.

Group I Wiring: 1 to 7 Actuation Levels

Group II Wiring: 1 to 4 Actuation Levels

Group III Wiring: 1 to 3 Actuation Levels

Group IV Wiring: 1 to 2 Actuation Levels

Switch (N.O. or N.C.):

SPST: 20 VA or 100 VA

SPDT: 20 VA

Lead Wires: #22 AWG, 24" L., PVC

Typical Wiring Diagrams

For clarity, only two actuation levels are shown in each group diagram.

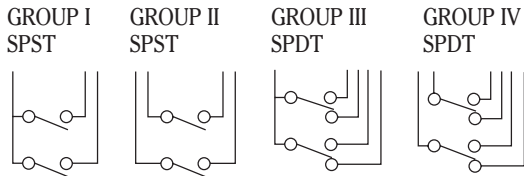

Wiring Color Code

Wiring	SPST Switches			SPDT Switches 20 VA				
	Group I	Group II		Group III		Group IV		
Com. Wire	Black	None		Black		None		
	NO/NC	SW. Com.	NO/NC	NO	NC	SW. Com.	NO	NC
L1	Red	Red	Red	Red	Wh/Red	Red	Wh/Red	Wh/Blk/Red
L2	Yellow	Yellow	Yellow	Yellow	Wh/Yel	Yellow	Wh/Yel	Wh/Blk/Yel
L3	Blue	Blue	Blue	Blue	Wh/Blue			
L4	Brown	Brown	Brown					
L5	Orange							
L6	Gray							
L7	White							

Notes: See "Electrical Data" on Page X-5 for more information.

4. Actuation Level Dimensions

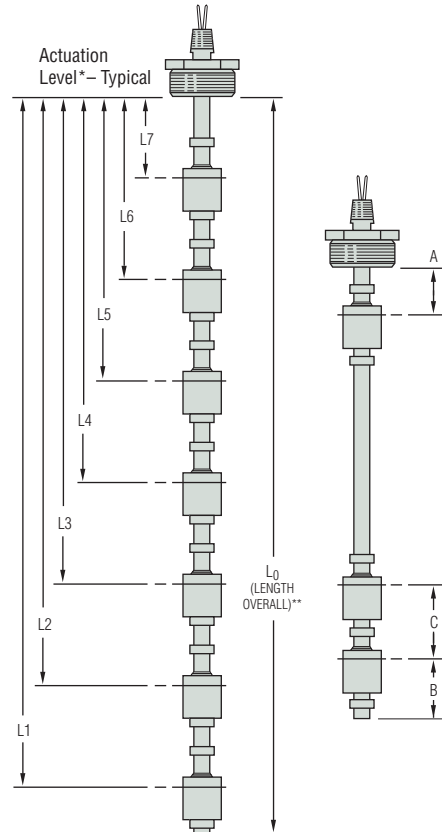

Switch actuation levels are determined following the guidelines below.

A = 1-1/2" (38.1 mm) Minimum distance to highest actuation level.

B = 2" (50.8 mm) Minimum distance from end of unit to lowest actuation level.

C = 3" (76.2 mm) Minimum distance between actuation levels.

Notes:

1. Actuation levels are calibrated on descending fluid level, with water as the calibrating fluid, unless otherwise specified.
2. A and B dimensions based on a top mounted unit.
3. Float stops are permanently cemented in place.
4. Tolerance on actuation levels is $\pm 1/8"$ (3.2 mm).
5. Dimensions based on a liquid specific gravity 1.0.

* Actuation level distances and L_0 (overall unit length) are measured from inner surfaces of mounting plug or flange.

** Length Overall (L_0) = L_1 + Dimension B. See Mounting Types for Maximum Length values.