

CODE	CALIPER OPTION	PART NO.
08	CALIPER - MECH. APPLY	01-266-0080
09	CALIPER - SPRING APPLY	01-266-0090
13	CALIPER SPRING APPLY	01-266-0130
14	CALIPER - SPRING APPLY	01-266-0140
15	CALIPER - HYD. APPLY	01-266-0150
17	CALIPER - SPRING APPLY	01-266-0170

X49B-AB.IDW
EFFECTIVE
FROM S/N 57755 9-15-98
TO: CURRENT

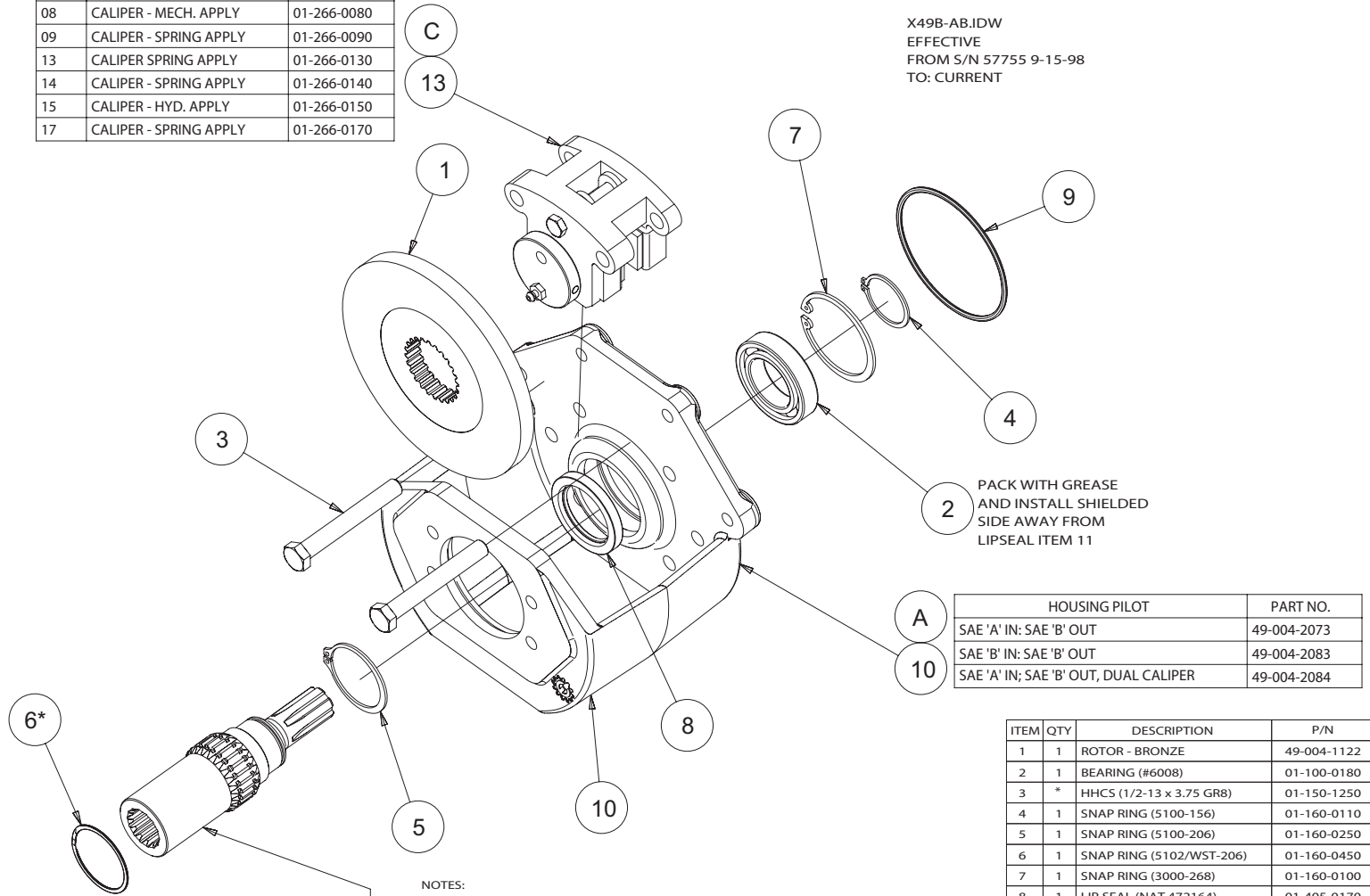

HOUSING PILOT		PART NO.
SAE 'A' IN; SAE 'B' OUT		49-004-2073
SAE 'B' IN; SAE 'B' OUT		49-004-2083
SAE 'A' IN; SAE 'B' OUT, DUAL CALIPER		49-004-2084

ITEM	QTY	DESCRIPTION	P/N
1	1	ROTOR - BRONZE	49-004-1122
2	1	BEARING (#6008)	01-100-0180
3	*	HHCS (1/2-13 x 3.75 GR8)	01-150-1250
4	1	SNAP RING (5100-156)	01-160-0110
5	1	SNAP RING (5100-206)	01-160-0250
6	1	SNAP RING (5102/WST-206)	01-160-0450
7	1	SNAP RING (3000-268)	01-160-0100
8	1	LIP SEAL (NAT 472164)	01-405-0170
9	1	O-RING (#242)	01-402-0220
10	1	HOUSING ASS'Y	-A-
11	1	SHAFT	-B-
12	*	CALIPER	-C-

SHAFT OPTIONS	PART NO.
14T 12/24 IN: 14T 12/24 OUT	49-004-1193
14T 12/24 IN: 13T 16/32 OUT	49-004-1183
14T 12/24 IN: 1-6B OUT	49-004-1173

NOTES:

1. A SECOND CALIPER IS OPTIONAL, ITEM 3 IS 2 OR 4 ACCORDINGLY
2. HOUSING IS PROVIDED WITH 2 & 4 BOLT PATTERNS FOR UP TO 6 MOUNTING CAPSCREWS. WITH DUAL CALIPERS, 2 CAPSCREWS IN 4 BOLT PATTERN WILL INTERFERE WITH CALIPERS
3. CALIPER MAY BE MOUNTED IN MIDDLE POSITION (AS SHOWN), OR EITHER SIDE POSITION
4. MINIMUM USABLE ROTOR THICKNESS IS .375" (NEW = 0.500")
5. SEAL KIT IS P/N 49-01601201 (INCLUDES ITEM 8 & 9) REPLACEMENT PAD KIT (ALL CODES) IS P/N 01-266-0160. ONE KIT PER CALIPER. CALIPER (ITEM 12) MUST BE REPLACED AS A UNIT. NO SEAL KIT IS AVAILABLE.
6. ITEM 6 MAY BE EITHER A MULTI-TURN SPIRAL RETAINING RING, OR A BEVELED SNAPPING. WHEN USING BEVELED RING, BEVELED EDGE MUST FACE AWAY FROM DISC.