



ELC-GP04

Instruction Sheet

GRAPHIC PANEL SERIES

WARNING

- DANGER - DC input power must be disconnected before any maintenance. Do not connect or disconnect wires and connectors while power is applied to the circuit. Maintenance must be performed by qualified technicians.
- DANGER - The ELC-GP04 requires 24VDC input power. The 24VDC input power should not be connected to the RS-485 communication port. The unit may be destroyed or can't be repaired if the input power is improperly applied. Please always check the correctly input power wiring before apply power.
- DANGER - An electrical charge will remain on the DC-link capacitors for 1 minute after power has been removed. Do not conduct any wiring or investigation on the ELC-GP04 until 1 minute after power has been removed. Do NOT touch terminals when power on.
- CAUTION - Always ground the ELC-GP04 by using the grounding terminal. Not only this acts as a safety, but also filter out electrical noise. The ground method must comply with the laws of the country where the unit is to be installed.
- CAUTION - ELC-GP04 may be damaged if the fixed support (shipped with the pack) is adjusted too tight.
- Please carefully read this instruction before using the ELC-GP04.
- The ELC-GP04 display panel is waterproof. But please prevent grease, corrosive liquids and sharp objects from contacting the ELC-GP04.
- Battery replacement: please use UL component type: CR2032 lithium battery (NOTE: RTC should be reset after changing battery).
- Do not disconnect while circuit is live unless area is known to be non-hazardous.
- This equipment is suitable for use in Class I, Division 2, Groups A, B, C, D or Non-Hazardous Locations only.
- Explosion Hazard – Substitution of components may impair suitability for class I, Division 2.
- Explosion Hazard – Do not disconnect equipment unless power has been switched off or the area is known to be Non – Hazardous.
- Power, input and output (I/O) wiring must all be in accordance with Class I, Division 2 wiring methods, Article 501-4 (b) of the National Electrical Code, NEPA 70, or as specified in Section 18-152 of the Canadian Electrical Code for units installed within Canada, and in accordance with that location's authority.

1 INTRODUCTION

1.1 Model Explanation

Thank you for choosing Eaton Logic Controller (ELC) GP Series. The features of ELC-GP04 are: resolution is 128*64, display 8*4 Chinese characters (max.) and multi-language support. It is built-in two communication ports (RS-232 and RS-485/RS-422, can be used simultaneously), and Built-in RTC and communication/alarm indication LED.

Possess extension slot for ELC-GPXFERMOD to copy settings and programs rapidly and save download time. Built-in variety objects to meet your requirement.

1.2 Outline



1.3 Panel Function Explanation

PANEL COMPONENT	EXPLANATION
Alarm Indication LED (RED)	Status 1: When power is on, the LED will flash three times slowly. Status 2: When there is an abnormal situation, the LED will flash quickly along with an alarm sound.
RS-232 Indication LED (Yellow)	It will be flashing when transmitting program and communicating by using RS-232.
RS-485/RS-422 Indication LED (Green)	It will be flashing when communicating by using RS-485/RS-422.
LCD Display Area	Liquid Crystal Module display area used to display current program state.
Escape/Exit	Used to cancel an incorrect input, or to Exit a programming step.
Arrow Keys	UP/Pg Up: Used to increase the value or move up one page. Pg Dn/DOWN: Used to decrease the value or move down one page. Left: Left direction key. (move cursor to left) Right: Right direction key. (move cursor to right)
Shift Key	Used to select keys F5, F6, F7, F8, F9.
Enter Key	Used to input a value or accept a programming command.
Function Keys	F0/F5: They are used to be constant 0 (F0) and 5 (Shift+F0) when they are in system menu and user can define the functions separately when they are in user page. F1/F6: They are used to be constant 1 (F1) and 6 (Shift+F1) when they are in system menu and user can define the functions separately when they are in user page. F2/F7: They are used to be constant 2 (F2) and 7 (Shift+F2) when they are in system menu and user can define the functions separately when they are in user page. F3/F8: They are used to be constant 3 (F3) and 8 (Shift+F3) when they are in system menu and user can define the functions separately when they are in user page. F4/F9: They are used to be constant 4 (F4) and 9 (Shift+F4) when they are in system menu and user can define the functions separately when they are in user page.

1.4 Back Panel

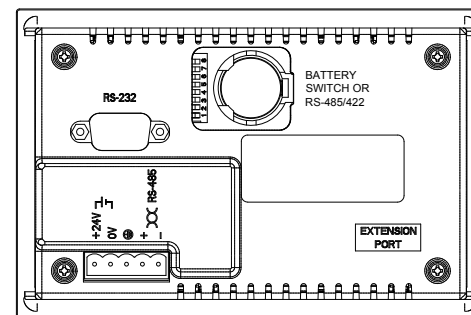

5-PIN terminals:
Wire gauge: 12-24 AWG
Torque: 4.5 lb.-inch

1.5 Dimension

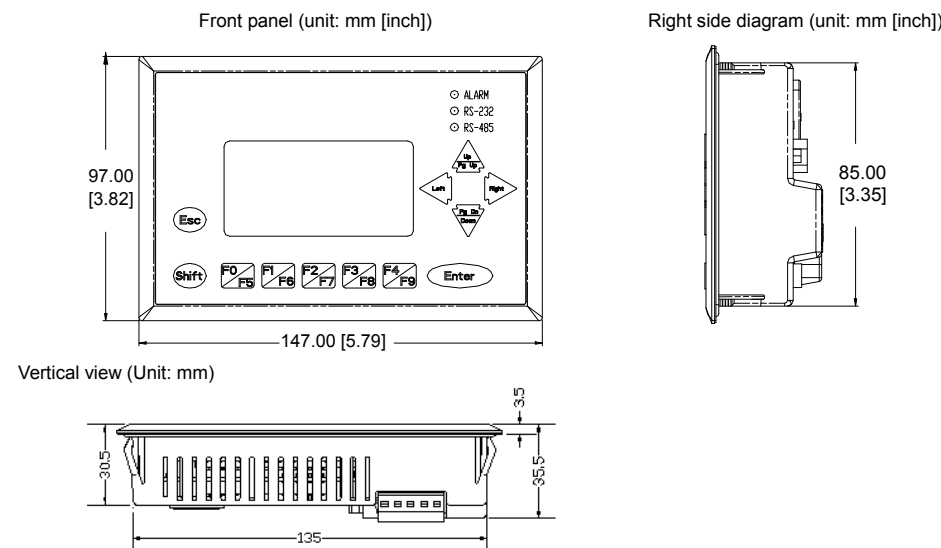

1.6 Installation

Mounting ELC-GP04 into the opening is done by carefully fitting the unit into the opening and pressing firmly on all four corners. You could fix it by using the fixed support packaged with ELC-GP04.

Warning: If you turn the screw exceeds torque: 4-5(kg-cm), ELC-GP04 may be damaged. (Note : the flat surface should be a Type 4 "Indoor Use Only" enclosure or equivalent.) Please leave sufficient space (more than 50mm) around the unit for heat dissipation.

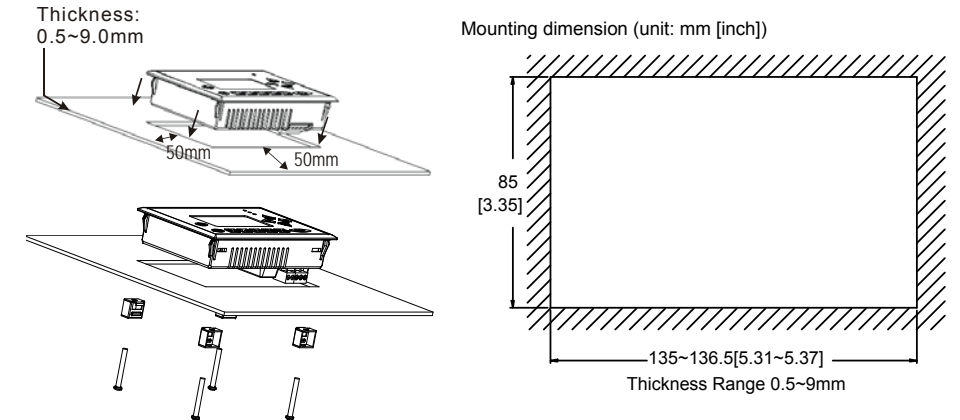

2 SPECIFICATION

2.1 Electrical Specification

ITEM	ELC-GP04
Function Key/Digital Key	F0~F4, ESC, SHIFT, ENTER and ARROW keys
External Input Power	24VDC (-15%~20%) 3.5W MAX.
Memory Capacity	256K Byte
CPU	Hitachi HD64F3064F
RAM of System	32K Byte
Communication Interface	COM1: RS232; COM2: RS485/RS422(See Section 6)
Waterproof Class of Front Panel	IP65/NEMA4/UL Type 4 (indoor use)
Environment Condition	0~50°C, relative humidity 20-90% RH (non-condensing)
Storage Temperature for Hardware	-20~60°C
Vibration	5Hz ≤ f < 9Hz = Continuous: 1.75mm / Occasional: 3.5mm 9Hz ≤ f ≤ 150Hz = Continuous: 0.5g / Occasional: 1.0g
Impact	15g peak, 11ms duration, half-sine, three shocks in each direction per axis, on 3 mutually perpendicular axes (total of 18 shocks)
Radiated Emission	CISPR11, Class A
Electrostatic Discharge Immunity	EN61000-4-2
Radiated Immunity	EN61000-4-3
Electrical Fast Transient	EN61000-4-4
Weight/Dimension	0.24kg/147×97×35.5mm (Width × Height × Deep)
Cooling Method	Natural Air Cooling
Temperature Code	T6
Hazardous Location rating	Class I, Division 2, Group A, B, C, and D

2.2 Function Specification

ITEM	ELC-GP04
Screen	STN-LCD
Color	Monochromatic
Backlight	The back-light automatic turn off time is 1~99 minutes (0 = do not turn off) (back-light life is about 50 thousand hours at 25°C)
Resolution	128X64 Points
Display Range	72mm (W) X 40mm (H); 3.00" (diagonal preferred)
Contrast Adjustment	10-step contrast adjustment

Font	ASCII: characters Other: user define	
Maximum Words x Rows, for Each Font Size	5X 8: 25 words X 8 rows	
	8X8: 16 words X 8 rows	
	8X12: 16 words X 5 rows	
	8X16: 16 words X 4 rows	
Font Size	ASCII: 5X8, 8X8, 8X12, 8X16	
Alarm Indication LED (RED)	1. Power on indication (Flash three times) 2. Flash for communication error or other alarm 3. Special Indication by user programming	
RS-232 Indication LED (Yellow)	It will be flashing when transmitting program and communicating by using RS-232.	
RS-485/RS-422 Indication LED (green)	It will be flashing when communicating by using RS-485/RS-422.	
Program Memory	256KB flash memory	
External Interface	Serial Communication Port RS-232 (COM1)	RS-232 Data length: 7 or 8 bits, Stop bits: 1 or 2 bits Parity: None/Odd/Even, Transmission speed: 9600bps~115200bps RS-232: 9 PIN D-SUB male
	Extension Communication Port RS-422/RS-485 (COM2)	RS-485/RS-422 Data length: 7 or 8 bits, Stop bits: 1 or 2 bits Parity: None/Odd/Even Transmission speed: 9600bps~115200bps RS-422: 9 PIN D-SUB male RS-485: 5-Pin removal terminal
	Extension Slot	1. Update program version 2.The slot for program copy card
	Battery Cover	DC 3V battery for HMI
	5-Pin Removal Terminal	There are DC 24V input and RS-485 input

3 TRANSFER MODULE

The function of transfer module that ELC-GP04 provides to copy user program, system function and passwords is different from the copy program. It is used to copy the whole HMI environment settings and application programs to another HMI rapidly. It can save much time and manpower. The operation is in the following.

Definition: Transfer module (ELC-GPXFERMOD) = XMOD, GP Series = GP

Step	GP→XMOD	XMOD→GP
1	Turn the switch on the XMOD to GP→XMOD	Turn the switch on the XMOD to XMOD→GP
2	Insert the XMOD into the extension slot of GP	Insert the XMOD into the extension slot of GP
3	Input the power to GP	Input the power to GP
4	It will display "remove XMOD" on the screen and power on again	It will display "remove XMOD" on the screen and power on again

HMI display message

Copy HMI program to XMOD (GP→XMOD)	Copy XMOD program to HMI (XMOD→GP)
If the model type of GP does not correspond with the model type of program of XMOD, GP will display "GP series and XMOD is different. Press Enter to Confirm GP series→XMOD. Press Esc to Exit".	If there is no program in XMOD, GP will display "The XMOD is Empty. XMOD→GP series is illegal".
GP will display "GP →XMOD series Please wait!" during transmission.	GP will display "XMOD → GP series Please wait!" during transmission.
GP will display "Please Remove the XMOD and Reboot !" when completing transmitting.	GP will display "Please Remove the XMOD and Reboot !" when completing transmitting.

4 PASSWORD FUNCTION

- If the password is forgotten, the password may be cleared using the following code: **8888**. This universal code will clear the password and all internal programs of ELC-GP04. The ELC-GP04 will be re-set to the factory settings.
- Users may use 0~9 and A~Z as characters for the password. Users must use the function keys F0~F4 to input the password characters.
F0/F5: scrolls in a loop as follows 0 → 5 → A → B → C → D → E → F → 0

- F1/F6: scrolls in a loop as follows 1 → 6 → G → H → I → J → K → 1
 F2/F7: scrolls in a loop as follows 2 → 7 → L → M → N → O → P → 2
 F3/F8: scrolls in a loop as follows 3 → 8 → Q → R → S → T → U → V → 3
 F4/F9: scrolls in a loop as follows 4 → 9 → W → X → Y → Z → 4

5 HARDWARE OPERATION

The steps to Startup the ELC-GP04:

- Apply 24V DC power,
- Enter into the startup display,
- Enter the user-designed program,
- Press Esc key and hold on for 5 seconds to return to system menu.

There are five selections in the system menu and are described below.

SELECTIONS	EXPLANATION
Download Program	Use the connection cable (ELC-CBPCCGP3) to connect the serial communication port RS-232 of ELC-GP04 to a PC. Then use the ELCSoftGP software to download an application program to the ELC-GP04.
Upload Program	Use the connection cable (ELC-CBPCCGP3) to connect the serial communication port RS-232 of ELC-GP04 to a PC. Then use the ELCSoftGP software to upload an application program from the ELC-GP04.
Copy Program	Transfer a program between two ELC-GP04 units. 1: transmit programs 2: receive programs When transmitting programs and data between two ELC-GP04 units. Set one ELC-GP04 to "Receive Program" mode and the other ELC-GP04 to "Transmit Program" mode. Please use twisted pair wires to connect the two units via the RS-485 ports.
ELC-GP04 Settings	There are 8 items that used to modify ELC-GP04 system settings: 1. Communication protocol: Setting the address of ELC-GP04, the control port of ELC, and the communication string for either RS-232 or RS-485. 2. Contrast: Adjust the contrast of LCD screen. 3. Back-light: adjust the automatic turn off time of LCD. Setting range is 00~99 seconds. If set to 00, the LCD Back-light will not turn off. 4. Date and Time: It is used to set the ELC-GP04 built-in RTC including year, month, day, hour, minute, second and week. Also the internal battery capacity display is shown here. 5. Buzzer: Used to set the buzzer sound, normal mode or quiet mode. 6. Language Setting: Used to set the displayed language. English, Traditional Chinese, simplified Chinese or user defined language. 7. Password setting: Used to set, enable, and disable the password function. If the password function is enabled, it will require the user to input a password before entering any system menu. The factory password is 1234. 8. Startup display: Used to select the ELC-GP04 startup display. User can select "user defined" to use the file that designed by ELCSoftGP and download to ELC-GP04. 9. Comm. Indicator : Used to select the communication Indicator enable or disable.
ELC Connection	There are three methods to connect to ELC: Using serial communication port (COM1) RS-232 of ELC-GP04: set 8-pin DIP switch to RS-485 mode and connect the cable (ELC-CBPCELC3) to program communication I/O RS-232C of ELC. Using extension communication port (COM2): set 8-pin DIP switch to RS-485 mode and connect 5-pin removal terminal of extension communication port to RS-485 of ELC with twisted pair. Using extension communication port (COM2): set 8-pin DIP switch to RS-422 mode and connect four pins (6, 7, 8, 9) of 9 PIN D-SUB male to RS-422 of ELC with 4-wire cable.
Execution	Execute the internal program that download from ELCSoftGP or transmitted from other ELC-GP04 units. When entering execution program, you can return to system menu by pressing Escape/Exit (Esc) key for 5 seconds.

6 COMMUNICATION CONNECTION

- ELC-GP04 may connect to a PC by using cable ELC-CBPCCGP3

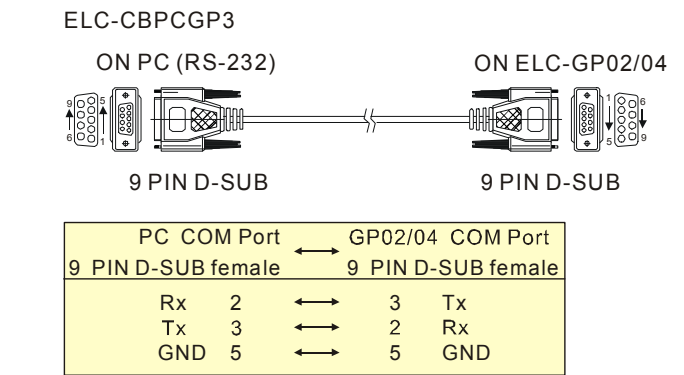

- ELC-GP04 may connect to a ELC by using cable ELC-CBPCELC3

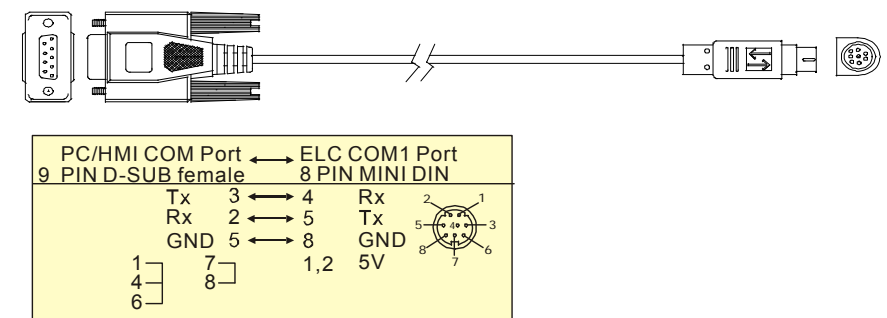

- The Pin definition of 9 PIN D-SUB

RS-232:

ELC-GP04 COM Port RS-232 9 PIN D-SUB male	
3	Tx
2	Rx
5	GND

RS-422:

ELC-GP04 COM Port RS-422 9 PIN D-SUB male	
6	Rx +
7	Rx -
8	Tx +
9	Tx -

- Switch between RS-422 / RS-485 (by using 8-PIN DIP switch)

8-PIN DIP switch	RS-485	RS-422
SW1~SW4	On	Off
SW5~SW8	Off	On

7 BATTERY LIFE AND PRECISION OF CALENDAR TIMER

- Battery life

Temperature (°C)	-20	0	20	60
Life (year)	1.972	2.466	2.712	2.835

- Precision of calendar timer(sec)

- At 0°C/32°F, less than -117 seconds error per month.
- At 25°C/77°F, less than 52 seconds error per month.
- At 55°C/131°F, less than -132 seconds error per month.