

Type S811+, Soft Starters with Digital Interface Module (DIM)



Contents

Description	Page
Type S611, Soft Starters	V6-T1-43
Type S801+, Soft Starters	V6-T1-59
Type S811+, Soft Starters with DIM	
Communications	V6-T1-76
Operation	V6-T1-76
Features and Benefits	V6-T1-79
Standards and Certifications	V6-T1-83
Instructional Leaflets	V6-T1-83
Catalog Number Selection	V6-T1-83
Product Selection	V6-T1-84
Accessories	V6-T1-88
Options	V6-T1-89
Technical Data and Specifications	V6-T1-90
Wiring Diagrams	V6-T1-94
Dimensions	V6-T1-95

Type S811+, Soft Starters with DIM

Product Description

Eaton's S811+ offers all the popular features of the S801+ and adds new enhanced functionality with the new Digital Interface Module (DIM), communications, metering, monitoring and diagnostics capabilities.

Eaton's line of S811+ reduced voltage soft starters is very compact, multi-functional, easy to install and easy to set operating parameters. Designed to control the acceleration and deceleration of three-phase motors up to 690 V, the line is available from 11A to 1000A.

The S811+ is designed to be a complete package, combining the silicon controlled rectifiers (SCRs), bypass contactor and overload in one, very compact unit. The S811+ is available as a component for panel mounting, in motor control centers or in enclosed control (NEMA Type 1, 3R, 4, 4X, 7/9 and 12).

Application Description

Designed to control the acceleration and deceleration of three-phase motors, the S811+ soft starter uses SCRs to control the voltage to soft start and soft stop the motor. After the motor is started, internal run bypass contactors close, resulting in the motor running directly across-the-line. The built-in solid-state overload protects the motor from overload conditions with sophisticated algorithms that model true motor heating, resulting in better motor protection and fewer nuisance trips. Advanced protective and diagnostic features reduce downtime.

A voltage ramp start or current limit start is available. Kick start is available in either starting mode. The soft stop option allows for a ramp stop time that is longer than the coast to stop time. The pump control option in the S811+ Premium provides a smooth transition for starting and stopping a motor and eliminating the "water-hammer" effect that can damage pipes, valves and pumps.

The S811+ offers an impressive array of advanced protective features. Not only are the protective features selectable, but many offer variable settings and adjustable time delays to ride through system discrepancies. Protective features may also be set to Warning status to avoid nuisance trips.

The S811+ has an easy to use Digital Interface Module (DIM) that allows the user to configure the device and to read system parameters and monitor system values. The DIM includes an LCD display and keypad to scroll through the various menus. The DIM allows the user to modify control parameters, enable or disable protections, set communication variables, monitor system parameters such as line voltages and currents, and access the fault queue.

The DIM can be removed from the S811+ and be remote mounted. Kits are available to door mount the DIM, enabling users to safely configure, commission, monitor and troubleshoot the system at the electrical panel without opening the enclosure door. This will help eliminate the possibility of an arc flash incident.

Digital Interface Module (DIM)

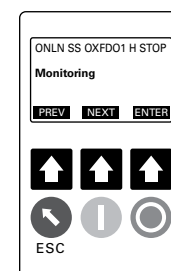

1

Communications

The S811+ has native Modbus RTU communication capabilities. The S811+ may be connected to a variety of networks, including DeviceNet, Modbus TCP, EtherNet/IP and PROFIBUS.

The S811+ communication parameters can be configured with the DIM or through the Fieldbus using CH Studio Component Manager. Advanced communication configuration settings provide the system integrator with powerful tools to facilitate system optimization

Communications Reference

Description	Part Number
Modbus TCP Communication Adapter with 120 Vac I/O	C441U
Modbus TCP Communication Adapter with 24 Vdc I/O	C441V
EtherNet/IP Communication Adapter with 120 Vac I/O	C441U
EtherNet/IP Communication Adapter with 24 Vdc I/O	C441V
85–264 Vac input, 24 Vdc output	PSG240E
360–575 Vac input, 24 Vdc output	PSG240F

Operation

Starting and Stopping Modes

The S811+ has a variety of starting and stopping methods to provide superior performance in the most demanding applications. The motor can be started in either voltage ramp start or current limit start mode. Kick start and soft stop are available within both starting modes. The user has the option to configure two independent start ramp profiles to accommodate variations in starting requirements.

Voltage Ramp Start

Provides a voltage ramp to the motor resulting in a constant torque increase. The most commonly used form of soft start, this start mode allows

you to set the initial torque value and the duration of the ramp to full voltage conditions. Bypass contactors close after ramp time.

- Adjustable initial torque 0–85% of locked rotor torque
- Adjustable ramp time 0.5–180 seconds (0.5–360 seconds with the S811+ Premium)

Starting Characteristics—Ramp Start

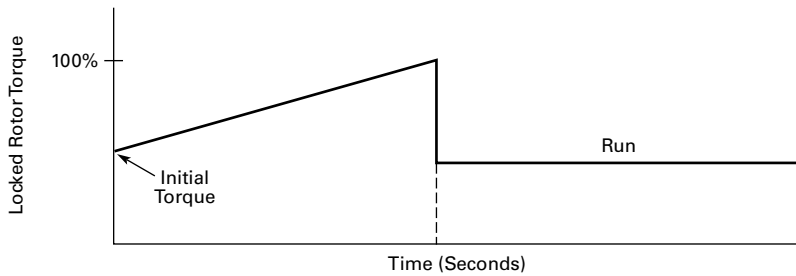

Current Limit Start

Limits the maximum current available to the motor during the start phase. This mode of soft starting is used when it becomes necessary to limit

the maximum starting current due to long start times or to protect the motor. This start mode allows you to set the maximum starting current as a

percentage of locked rotor current and the duration of the current limit. Bypass contactors close after current limit time.

- Maximum current of 0–85% locked rotor current
- Adjustable ramp time 0.5–180 seconds (0.5–360 seconds with the S811+ Premium)

Starting Characteristics—Current Limit Start

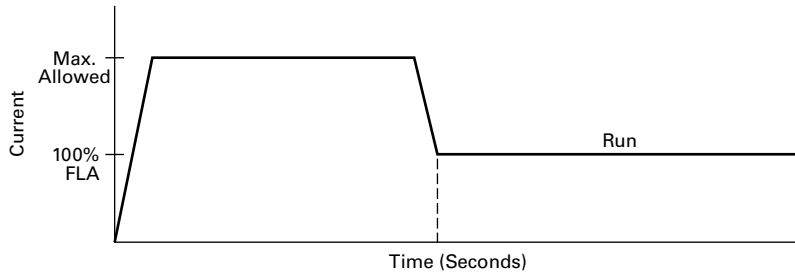

Kick Start

Selectable feature in both voltage ramp start and current limit start modes. Provides a current and torque “kick” for 0 to 2.0 seconds.

This provides greater initial current to develop additional torque to breakaway a high friction load.

- 0–85% of locked rotor torque
- 0–2.0 seconds duration

Starting Characteristics—Kick Start

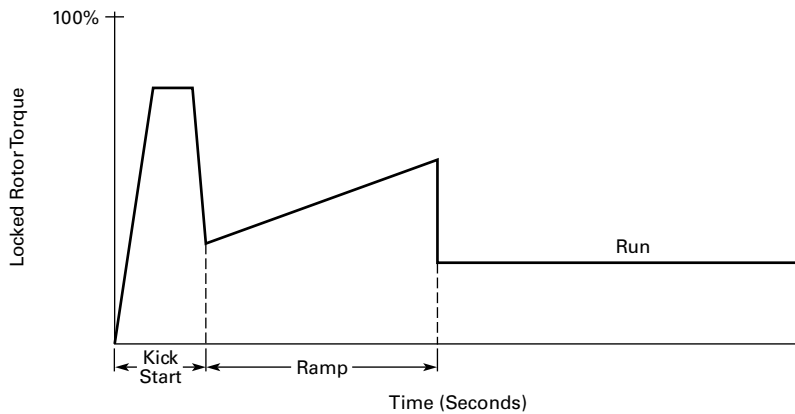

Soft Stop

Allows for a controlled stopping of a load. Used when a stop-time that is greater than the coast-to-stop

time is desired. Often used with high friction loads where a sudden stop may cause system or load damage.

- Stop time = 0–60 seconds

Starting Characteristics—Soft Stop

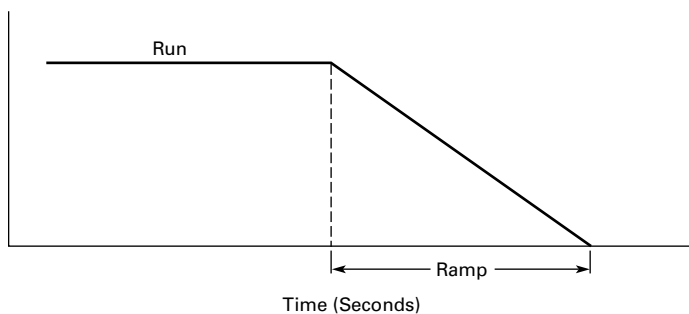

Edge and Level Sensing Control**Edge Sensing**

Edge sensing requires +24 Vdc power be momentarily applied to Control Terminal Block Pin 1 (with Terminal P at +24 Vdc) to initiate a start under all conditions. After a stop or fault occurs, the +24 Vdc must be removed, then reapplied to Terminal Pin 1 before another start can occur. This control configuration should be used when restarting of the motor after a fault or stop must be supervised manually or as a part of a control scheme. The cycling of +24 Vdc power to Terminal 1 Pin before starting is required regardless of the position of the auto reset switch on the DIM.

Level Sensing

Level sensing will enable a motor to restart after a fault is cleared without cycling +24 Vdc power to Terminal Pin 1 as long as:

- Terminal Pin P is supplied with +24 Vdc (to start from Control Terminal Block, Terminal Pin 3 must also be enabled)
- The auto reset switch on the DIM is set to enabled
- All faults have been reset

This control configuration should be used where it is desirable to restart a motor after a fault without additional manual or automatic control. An example of this condition would be on a remote pumping station where it is desirable to automatically restart a pump after a power outage without operator intervention.

Note: If the auto reset feature is used, CAUTION must be exercised to ensure that any restart occurs in a safe manner.

Features and Benefits

- Communication capabilities with various protocols
- The Digital Interface Module (DIM) provides an intuitive, easy-to-use human interface with powerful configuration capabilities to maximize system performance
- Door or device mounted DIM enables users to safely configure, commission, monitor and troubleshoot the system at the electrical panel without opening the enclosure door, eliminating the possibility of an arc flash incident
- System operating parameters can be monitored enterprise-wide through a communications network. Increase uptime by providing data for process management and preventive diagnostics
- Run internal bypass mode greatly reduces internal heating created by the greater power dissipation in the SCRs. Bypass contactor directly connects the motor to the line and improves system efficiency by reducing internal power losses
- Internal solid-state overload protection provides accurate current measurement and trip settings. Sophisticated algorithms solve a series of differential equations that model true motor heating and cooling, resulting in superior motor overload protection while minimizing nuisance trips. Advanced selectable protective features safeguard the motor and system against a variety of system faults
- Internal run bypass contactors and overload protection eliminate the need for additional devices, reducing enclosure sizes, minimizing installation and wiring time, and reducing overall assembly size and cost
- Wide range of overload FLA settings (31–100% of rated current) and a selectable trip class (5–30) offers users the flexibility to fine tune the starter to match specific application requirements
- Variable ramp times and torque control settings provide unlimited starting configurations, allowing for maximum application flexibility
- Kick-start feature enables soft starting of high friction loads
- Soft stop control for applications where an abrupt stop of the load is not acceptable
- The S811+ Premium with sophisticated pump control algorithms on both starting and stopping that minimize the pressure surges that cause water hammer. The pump control feature will maximize the life of the pump and piping systems while minimizing the downtime caused by system failure
- Six SCRs control all three motor phases, providing smooth acceleration and deceleration performance
- Soft acceleration and deceleration reduces wear on belts, gears, chains, clutches, shafts and bearings
- Reduce the peak inrush current's stress on the power system
- Manage peak starting torque to diminish mechanical system wear and damage
- 24 Vdc control voltage enhances personnel and equipment safety
- Removable, lockable control terminal block reduces maintenance costs. Also provides the opportunity for OEMs to reduce assembly and test costs by utilizing pre-assembled wire harnesses

Motor Wiring Configuration User Selectable Inline or Inside-the-Delta

Mains Motor Wiring Configuration is accomplished by simply selecting the required configuration from a menu. This feature allows adaptability from one configuration to another without any additional programming operations and reduces inventory levels by not having to stock both configurations.

Modbus Native Communications Protocol

Modbus RTU communications is now standard on all S811+ units. This allows users to quickly configure the unit for network communications using a common protocol. Adapters are available for users who prefer to use EtherNet/IP or Modbus TCP protocols.

Programmable Control Terminal Block Functionality

Four programmable terminals on the S811+ enable the user to expand functionality with options such as a second start ramp profile, externally triggered trip or warning functions, analog inputs, and others, in addition to the normal start, stop, reset, and so on, functions.

Second Start Ramp Profile Capability

A second start ramp profile may be configured for the soft starter. This profile is independent of the primary profile and retains all the parameter options such as start time and initial torques. With a signal at a terminal programmed for this feature, the second profile may be selected by a pushbutton station or a network.

Alarm-No-Trip Functionality

Some applications require the ability to effectively disable most protections with the intent of enabling the RVSS unit to control a motor under the most severe operating conditions characterized by current or voltage imbalances, high or low value deviations, or other fault conditions. This function causes the S811+ to ignore most fault trip conditions and continue operation of the application.

Digital Interface Module (DIM) Cloning

For OEMs or other users that desire to load identical parameter settings into multiple RVSS units, the DIM may be used to extract and duplicate parameter settings from one RVSS and loaded into other units, saving time, effort, and reducing chances for errors while programming.

Protective Features

All protective features can be configured, enabled or disabled with the DIM or through the communications network.

Motor Overload

The S811+ includes electronic overload protection as standard. The overload meets applicable requirements for a motor overload protective device. The overload protects the motor from over heat conditions with the use of sophisticated algorithms that model true motor heating, resulting in superior motor protection and fewer nuisance trips.

The S811+ calculates a thermal memory value based on the heat energy introduced into the motor during the start process. A 100% value represents the maximum safe internal temperature of the motor.

When the thermal memory value reaches 100%, an overload trip will occur removing power to the motor. Upon trip, the S811+ stores the calculated motor heating value and will not allow a motor re-start until the motor has a thermal memory value of less than 100%. This feature ensures the motor will not be damaged by repeated overload trip, reset and re-start cycles.

The thermal memory value can be monitored through the DIM or the communications network. The thermal memory value can be of great use in determining an impending overload trip condition. Alarms can be implemented in the process monitoring system warning of an impending trip before a trip occurs halting the process. Costly system downtime can be avoided.

The trip current is adjusted to match the specific application requirements by entering the motor nameplate full load current rating and trip class. The FLA parameter is adjustable from 32% to 100% of the unit's rated current. The overload trip class is adjustable from class 5 through class 30. The overload is ambient temperature compensated—meaning its trip characteristics will not vary with changes in ambient temperature. The overload protection can be enabled, disabled, or disabled on start.

Short Circuit

The use of a short-circuit protective device in coordination with the S811+ is required in branch motor circuits by most electrical codes. Short-circuit coordination ratings with both fuses and Eaton molded case circuit breakers are available providing customers with design flexibility. The S811+ has short-circuit coordination ratings as an open component, an enclosed starter, and in a motor control center.

External E-Stop

Emergency Stop functionality may be triggered from an external source. Removal of the 24 Vdc signal from a terminal configured for E-Stop will initiate an E-Stop action. The External E-Stop option is useful in applications where it is desirable to accomplish a motor shutdown in the event that an external condition(s) exist that will damage system components and/or product flows or operations.

External Trip

External Trip functionality may be triggered from an external source. Removal of the 24 Vdc signal from a terminal configured for External Trip will initiate an External Trip action. The External Trip option is useful in applications where it is desirable to accomplish a motor stop in the event that an external condition(s) exist that will damage system components and/or product flows or operations.

Fault Warning Functionality

Selected protection parameters may be assigned to provide a Fault Warning instead of a Fault Trip with user adjustable set points. When a Fault Warning condition is detected, the fault condition is reported via the DIM, network connection, or an auxiliary relay configured for this function. The soft starter remains in operation. At such time the fault condition no longer exists, the Fault Warning message will be extinguished.

External Warning

The S811+ will accept a Warning signal from an external source or device. In a fashion similar to the Fault Warning, the fault condition is reported via the DIM, network connection, or an auxiliary relay configured for this function. The soft starter remains in operation. At such time the fault condition no longer exists, the Fault Warning message will be extinguished.

Custom Fault/Warning Auxiliary Relays

Up to three fault and/or warning codes may be selected to operate an auxiliary relay configured to operate when any of these codes are detected. This option enables the user to provide external warnings or fault indications to increase monitoring effectiveness and to provide additional system control.

Motor Power

Motor Power can be not only be monitored, but trip levels can be adjusted to provide indications of system malfunctions or operating discrepancies. Both High and Low Power thresholds can be set to provide Fault Warning or Fault Trip functions. Additionally, fault delays times may be set to up to 60 seconds.

Analog Input

An input control terminal may be configured to accept a 0–20 mA DC signal with range scaling. This feature enables the S811+ to respond to an external device that may be monitoring a critical component or process and provides Fault Trip or Fault Warning capability to protect operating systems and processes.

Start Delay

Three start delay timers are available to enhance motor protection or to provide simple logic functions to coordinate motor control with other devices in the system. The timers will allow delays from 24 Vdc power up, receipt of a valid START command, or a delay in switch from one start ramp profile to another.

Jam

Excessive current and torque up to locked rotor levels can occur in a jam condition. The condition can result in stress and damage to the motor, load, mechanical system, and the electrical distribution system. Jam protection prevents the stress and damage from a jam during normal run. After the motor is in bypass, a current greater than 300% FLA setting will cause the starter to trip on a jam fault.

Stall

Excessive current and torque up to locked rotor levels can occur in a stall condition. The condition can lead to an overload trip and result in stress and damage to the motor, load, mechanical system, and the electrical distribution system. Stall protection prevents stress and damage to a motor that has not come up to speed during the soft start time. The S811+ will trip to protect the system in the event that the motor did not get to the rated speed in the defined soft start period. A current greater than 200% FLA at the end of the soft start period will cause the starter to trip on a stall fault.

Pole Over Temperature

High ambient temperatures, extended ramp times and high duty cycle conditions may cause the S811+ power pole conductors to reach a temperature that exceeds their thermal rating. The S811+ is equipped with sensors that monitor the temperature of the power poles. Over temperature protection occurs if the power pole's thermal capacity is exceeded. The soft starter will trip in over temperature conditions, preventing device failure.

Each power pole temperature value can be monitored through the DIM or the communications network. This feature can be of use in determining an impending over temperature trip condition.

When using a communications network, alarms can be implemented in the process monitoring system warning of an impending trip before the trip occurs, halting the process.

Phase Loss

Loss of a phase can cause a significant increase in the current drawn in the remaining two phases. Phase loss can lead to motor damage before an eventual overload trip occurs. Phase loss is typically an indication of a failure in the electrical distribution system. The S811+ will detect a phase loss and trip if any phase current drops below a preset value. The phase loss trip level is adjustable from 0% to 100% of the average of the other two phase levels with an adjustable trip delay of 0.1 to 60 seconds.

Phase Imbalance

Phase current or voltage imbalance can cause a significant increase in the current drawn in the remaining two phases. Phase imbalance can lead to motor damage before an eventual overload trip. Phase imbalance is typically an indication of a failure in the electrical distribution system or the motor. The S811+ will detect both current and voltage phase imbalances and trip if any phase becomes imbalanced as compared to the average of the other two phases.

The phase current imbalance trip level is adjustable from 0% to 100% of the average of the current in the other two phases with an adjustable trip delay of 0.1 to 60 seconds.

The phase voltage imbalance trip level is adjustable from 0% to 100% of the average of the voltage in the other two phases with an adjustable trip delay of 0.1 to 60 seconds.

Reset Mode

The S811+ can be set up for automatic or manual reset on trip. The manual reset mode requires the operator to physically press the RESET button located on the soft starter. The trip can be manually reset through the DIM or through the communications network. The trip can also be electrically reset by energizing a 24 Vdc input on the control terminal block.

The automatic reset mode allows the soft starter to be automatically reset as soon as the trip condition is no longer present. With the automatic reset mode, after the fault is no longer present, the motor will be restarted as soon as a valid start signal is present.

Phase Reversal

The S811+ can determine if the proper line phase sequence is present by default. The device will trip if the line phase sequence is something other than A-B-C. The S811+ can be configured to operate under reversed phase conditions (A-C-B).

Shorted SCR Detection

The S811+ monitors the operation of the power poles and will trip under a shorted SCR condition.

Open SCR Detection

The S811+ monitors the operation of the power poles and will trip under an open SCR condition.

Ground Fault Protection

The S811+ Premium and 690 V versions meet the IEC Ground Fault trip thresholds. Reference Application Note AP039007EN for more information.

Low Current

Low current conditions can be a result of a loss of load or a failure in the mechanical system. The S811+ has low current protection that will trip if the average rms current falls below a preset value. The low current protection can be programmed as a percent of motor FLA from 0% to 100%.

Low Voltage

Low voltage conditions can result from disturbances in the electrical power distribution system. Low voltage conditions can cause a malfunction and damage to electrical equipment. The S811+ has low voltage protection that will trip if the average rms voltage falls below a preset value. The low voltage protection can be programmed as a percent of nominal voltage from 1% to 99% with a trip delay of 0.1 to 60 seconds to accommodate short temporary voltage drops during the start process.

High Voltage

High voltage conditions can result from disturbances in the electrical power distribution system. High voltage conditions can cause malfunctions or failures of electrical equipment. The S811+ has high voltage protection that will trip if the average rms voltage is greater than a preset value. The high voltage protection can be programmed as a percent of nominal voltage from 101% to 120% with a trip delay of 0.1 to 60 seconds.

Monitoring Capabilities

The S811+ has an impressive array of system monitoring capabilities that allows users to access real time process and diagnostic data. This data can be viewed at the device with the DIM or through a communications network. Data over a communications network can provide valuable insight into the condition of the equipment and processes. Maintenance and production personnel can monitor critical operational and maintenance data from a central control station that can be located far away from the production facility. Process data can be monitored to determine system anomalies that may indicate a need for preventive maintenance or an impending failure. Adjustments made through the communications network can reduce costs by minimizing the time traveling to the location where the motor controls are located. When faults do occur, real time fault data can assist maintenance in troubleshooting and planning repair resources. Remote reset signals can be given to tripped devices without the need for manual intervention by maintenance personnel.

Average Line Current

Provides the average of the three-phase rms line currents in amps, accurate to within 2%. Current data can be used to indicate a need for maintenance. Increased currents in a fixed load application can indicate a reduction in system efficiencies and performance, signifying system maintenance is due.

Average Pole Current

Provides the average of the three-phase rms pole currents in amps, accurate to within 2%. The pole current is the current through the soft starter. The line and pole current will be identical in inline applications, and will differ in inside-the-delta applications.

Average Line Current as a % FLA

Provides the average rms line current as a percentage of the S811+ FLA setting.

Three-Phase Line Currents

Provides three rms phase line currents in amps, accurate to within 2%. Imbalances or changes in the relative phase current to one another can indicate anomalies in the motor or electrical distribution system.

Three-Phase Pole Currents

Provides three rms phase pole currents in amps, accurate to within 2%. The pole current is the current through the soft starter. The line and pole current will be identical in in-line applications, and will differ in inside-the-delta applications.

Three-Phase Line Voltages

Provides the individual rms three-phase line voltages. Imbalances or changes in the relative phase voltage to one another can indicate anomalies in the motor or electrical distribution system. Voltage can be used to monitor electrical distribution system performance. Warnings, alarms and system actions to low or high voltage conditions can be implemented.

Percent Thermal Memory

Provides the real time calculated thermal memory value. The S811+ calculates thermal memory value. A 100% value represents the maximum safe internal temperature of the motor. When the thermal memory value reaches 100%, an overload trip will occur, removing power to the motor.

The thermal memory value can be of great use in determining an impending overload trip condition. When using a communications network, alarms can be implemented in the process monitoring system warning of an impending trip before the trip occurs, halting the process. Costly system downtime can be avoided.

DC Control Voltage

Monitors level of the 24 Vdc control voltage. Fluctuations in control voltage can cause component malfunction and failure. System control voltage data can be used to implement warnings, alarms and system actions to low or high voltage conditions.

Pole Temperature

Increases in power pole temperature are caused by increases in ambient temperature, start/stop times and start duty cycles. Changes in pole temperatures represent a change in system operating conditions. Identifying unexpected operating conditions or changes can prompt maintenance and aid in process evaluation activities.

PCB Device Temperature

An increase in printed circuit board (PCB) device temperature is a strong indication of an increase in ambient temperature. High ambient temperature operation can be identified with the device temperature data. Device temperature increases can be due to undersized enclosures, failure of cooling fans or blocked venting. High operating temperatures will reduce the life of all electrical equipment in the enclosure.

Start Count

Start count data can be used to monitor system output, schedule preventative maintenance, identify system anomalies and identify changes in system operation.

Average Line Power

Provides the average of the three-phase line power in kilowatts, accurate to 5%. Power data may be used to monitor power transmitted to the load. Increased power demand may indicate degraded system components or connections. Additionally, such data is useful in determine power utilization in branch circuits consisting of multiple loads.

Power Factor

Provides the three-phase power factor value, accurate to 5%. The power factor of the circuit may be used to identify circuit conditions that may need to be corrected due to low power factor indications. Low circuit power factor can indicate improper or degraded components.

Diagnostics

Fault Queue

Current fault and a fault queue containing the last nine system faults can be read through the DIM or communications network. Fault identification can minimize troubleshooting time and cost, and prevent arc flash incidents. The fault queue can be remotely accessed through a communications network to assist in planning maintenance resources. Thirty (30) different faults can be identified by the S811+.

Control Status

The S811+ provides data that represents system conditions that can be read through the DIM or the communications network. This data identifies the status of the system and the control commands the system is requesting of the S811+. This can be used for advanced troubleshooting and system integration activities.

Breaker Status

The S811+ has provisions to read and display circuit breaker status. Eaton communicating cover control or other communicating protective device is required to take advantage of this feature.

Standards and Certifications

- IEC 60947-4-2
- EN 60947-4-2
- UL listed (NMFT-E202571) S811+N37... through S811+V85...
- UL recognized (NMFT2) S811+V10...
- CE marked
- CSA certified (3211 06)
- CSA elevator (2411 01)



Instructional Leaflets

- User manual MN03900001E
- Outline drawings:
 - S811+N...: 10-8574
 - S811+R...: 10-8575
 - S811+T...: 10-8576
 - S811+U...: 10-8857
 - S811+V...: 10-8577

Catalog Number Selection

S811+ Open Soft Starters ①

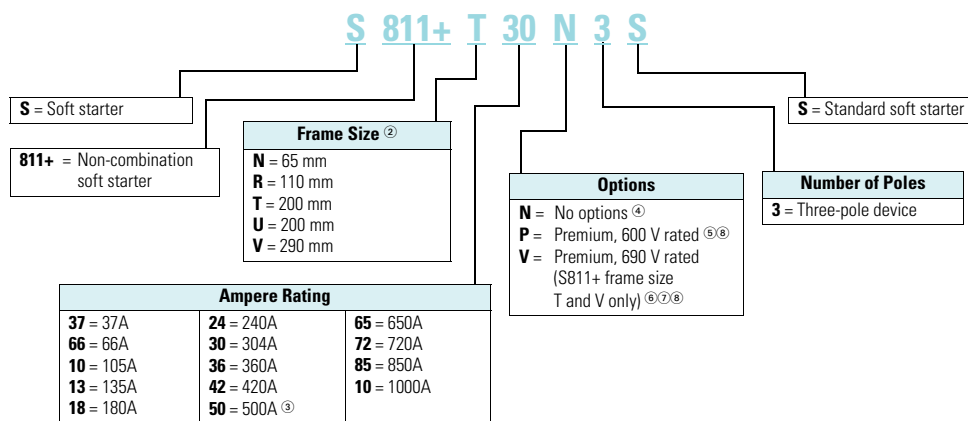

Notes

- ① All units require a 24 Vdc power supply found on catalog **Page V6-T1-88**, or equivalent.
- ② S811+T..., S811+U... and S811+V... units require lug kits found on **Page V6-T1-88**.
- ③ S811+U50... unit does not have IEC certification.
- ④ Level/Edge Sense, Inline or Inside-the-Delta wiring configuration.
- ⑤ Level/Edge Sense, Inline or Inside-the-Delta wiring configuration, pump control and extended ramp.
- ⑥ Not available in S811+U....
- ⑦ Level/Edge Sense, Inline wiring configuration, pump control, extended ramp.
- ⑧ Ground fault protection included.

Product Selection

Standard Duty Ratings

Starting Method	Ramp Current % of FLA	Ramp Time Seconds	Starts per Hour	Ambient Temperature
Soft start	300%	30 sec.	3	50°C
Full voltage	500%	10 sec.	3	50°C
Wye-delta	350%	20 sec.	3	50°C
80% RVAT	480%	20 sec.	2	50°C
65% RVAT	390%	20 sec.	3	50°C
50% RVAT	300%	20 sec.	4	50°C

Motor applications and customer needs come in many different varieties. With the standard and severe duty rating tables, we have attempted to provide

guidelines on what the soft starter is capable of. If the application falls under these categories, you can use these charts. For other applications, or when a

question arises, consult with your local Eaton representative or call our Technical Resource Center.

S811+



Standard Duty—15 Second Ramp, 300% Current Limit at 40°C, Inline Connection

Rated Current	Three-Phase Motors												Catalog Number ^①
	kW Rating (50 Hz)			hp Rating (60 Hz)									
	230 V	380–400 V	440 V	200 V		230 V		460 V		575–690 V			
			1.0SF	1.15SF	1.0SF	1.15SF	1.0SF	1.15SF	1.0SF	1.15SF	1.0SF	1.15SF	
Frame Size N													
37	10	18.5	18.5	10	10	10	10	25	20	30	30	S811+N37N3S	
66	18.5	30	37	20	15	20	20	50	40	60	50	S811+N66N3S	
Frame Size R													
105	30	55	59	30	25	40	30	75	60	100	75	S811+R10N3S	
135	40	63	80	40	30	50	40	100	75	125	100	S811+R13N3S	
Frame Size T													
180	51	90	110	60	50	60	60	150	125	150	150	S811+T18N3S	
240	75	110	147	75	60	75	75	200	150	200	200	S811+T24N3S	
304	90	160	185	100	75	100	100	250	200	300	250	S811+T30N3S	
Frame Size U													
360	110	185	220	125	100	150	125	300	250	350	300	S811+U36N3S	
420	129	220	257	150	125	175	150	350	300	450	350	S811+U42N3S	
500	150	257	300	150	150	200	150	400	350	500	450	S811+U50N3S^②	
Frame Size V													
360	110	185	220	125	100	150	125	300	250	350	300	S811+V36N3S	
420	129	220	257	150	125	175	150	350	300	450	350	S811+V42N3S	
500	150	257	300	150	150	200	150	400	350	500	450	S811+V50N3S	
650	200	355	425	250	200	250	200	500	450	600	500	S811+V65N3S	
720	220	400	450	—	—	300	250	600	500	700	600	S811+V72N3S	
850	257	475	500	—	—	350	300	700	600	900	700	S811+V85N3S	
1000	277	525	550	—	—	400	350	800	700	900	800	S811+V10N3S	

Notes

- ① Replace N3S with P3S for premium/pump option.
- ② S811+U50... rating does not have IEC certification.

Severe Duty

Severe Duty Ratings

Starting Method	Ramp Current % of FLA	Ramp Time Seconds	Starts per Hour	Ambient Temperature
Soft start	450%	30 sec.	4	50°C
Full voltage	500%	10 sec.	10	50°C
Wye-delta	350%	65 sec.	3	50°C
80% RVAT	480%	25 sec.	4	50°C
65% RVAT	390%	40 sec.	4	50°C
50% RVAT	300%	60 sec.	4	50°C

Severe duty ratings are defined as any combination of parameters that exceed the standard duty ratings where

the ramp time is over 30 seconds, and/or the number of starts per hour exceeds 4, and/or the current limit set is

over 300%. *Example:* 35-second ramp, 5 starts per hour, 350% current limit at 40°C ambient.

S811+



Severe Duty—30 Second Ramp and/or 450% Current Limit at 50°C, Inline Connection

Rated Current	Three-Phase Motors kW Rating (50 Hz)			hp Rating (60 Hz)				575–690 V				Catalog Number ^①
	230 V	380–400 V	440 V	200 V		230 V		460 V		575–690 V		
				1.0SF	1.15SF	1.0SF	1.15SF	1.0SF	1.15SF	1.0SF	1.15SF	
Frame Size N												
22	5.5	10	11	5	5	7-1/2	5	15	10	20	15	S811+N37N3S
42	11	18.5	22	10	10	15	10	30	25	40	30	S811+N66N3S
Frame Size R												
65	15	30	33	15	15	20	15	50	40	50	50	S811+R10N3S
80	22	40	45	25	20	30	25	60	50	75	60	S811+R13N3S
Frame Size T												
115	33	59	63	30	30	40	30	75	75	100	100	S811+T18N3S
150	45	80	90	50	40	50	50	100	100	150	125	S811+T24N3S
192	55	100	110	60	50	75	60	150	125	200	150	S811+T30N3S
Frame Size U												
240	75	110	147	75	60	75	75	200	150	200	200	S811+U36N3S
305	90	160	185	100	75	100	100	250	200	300	250	S811+U42N3S
365	110	185	220	125	100	150	125	300	250	350	300	S811+U50N3S^②
Frame Size V												
240	75	110	147	75	60	75	75	200	150	200	200	S811+V36N3S
305	90	160	185	100	75	100	100	250	200	300	250	S811+V42N3S
365	110	185	220	125	100	150	125	300	250	350	300	S811+V50N3S
420	129	220	257	150	125	150	150	350	300	450	350	S811+V65N3S
480	147	257	295	150	150	200	150	400	350	500	450	S811+V72N3S
525	160	280	335	150	150	200	150	450	350	500	450	S811+V85N3S
575	172	303	370	200	150	250	200	500	450	600	500	S811+V10N3S

Notes

- ① Replace N3S with P3S for premium/pump option.
- ② S811+U50... rating does not have IEC certification.

Inside-the-Delta Standard Duty Ratings

S811+

**Standard Duty— 15 Second Ramp, 300% Current Limit at 40°C, Inside-the-Delta Connection**

Rated Motor Line Current	Three-Phase Motor kW Rating (50 Hz)			hp Rating (60 Hz)								Catalog Number ^①
	230 V	380–400 V	440 V	200 V		230 V		460 V		575 V		
				1.0SF	1.15SF	1.0SF	1.15SF	1.0SF	1.15SF	1.0SF	1.15SF	
Frame Size N												
65	10	18.5	18.5	15	15	15	15	40	30	50	50	S811+N37N3S
114	18.5	30	37	30	25	30	30	75	60	100	75	S811+N66N3S
Frame Size R												
182	30	55	59	50	40	60	50	125	100	150	125	S811+R10N3S
234	40	63	80	60	50	75	60	150	125	200	150	S811+R13N3S
Frame Size T												
311	51	90	110	100	75	100	100	250	200	250	250	S811+T18N3S
415	75	110	147	125	100	125	125	300	250	300	300	S811+T24N3S
526	90	160	185	150	125	150	150	400	300	400	400	S811+T30N3S
Frame Size U												
623	110	185	220	200	150	250	200	450	400	550	450	S811+U36N3S
727	129	220	257	250	200	300	250	550	450	700	550	S811+U42N3S
865	150	257	300	250	250	300	250	600	550	750	700	S811+U50N3S ^{②③}
Frame Size V												
623	110	185	220	200	150	250	200	450	400	550	450	S811+V36N3S
727	129	220	257	250	200	300	250	550	450	700	550	S811+V42N3S
865	150	257	300	250	250	300	250	600	550	750	700	S811+V50N3S
1125	200	355	425	400	300	400	300	750	700	900	750	S811+V65N3S
1246	—	—	—	—	—	—	—	—	—	—	—	S811+V72N3S
1471	—	—	—	—	—	—	—	—	—	—	—	S811+V85N3S
—	—	—	—	—	—	—	—	—	—	—	—	S811+V10N3S

Notes

- ① Replace N3S with P3S for premium/pump option.
- ② S811+U50... unit does not have IEC certification.
- ③ 15 sec. start, 300% inrush, 40 °C, 1 start every 15 minutes. If these start parameters are exceeded, please refer to S811+V50...
Catalog numbers also represent P3S and V3S units.

Inside-the-Delta Severe Duty Ratings

Severe duty ratings are defined as any combination of parameters that exceed the standard duty ratings where the ramp time is over 30 seconds, and/or the number of starts per hour exceeds 4, and/or the current limit set is over 300%.

Example: 35-second ramp, 5 starts per hour 350% current limit at 40°C ambient.

S811+



Severe Duty—30 Second Ramp and/or 450% Current Limit at 50°C, Inside-the-Delta Connection

Rated Motor Line Current	Three-Phase Motor												Catalog Number ①
	kW Rating (50 Hz)			hp Rating (60 Hz)									
	230 V	380–400 V	440 V	200 V		230 V		460 V		575 V			
			1.0SF	1.15SF	1.0SF	1.15SF	1.0SF	1.15SF	1.0SF	1.15SF			
Frame Size N													
39	5.5	10	11	7-1/2	7-1/2	10	7-1/2	25	15	30	25	S811+N37N3S	
73	11	18.5	22	15	15	25	15	50	40	60	50	S811+N66N3S	
Frame Size R													
111	15	30	33	25	25	30	25	75	60	75	75	S811+R10N3S	
138	22	40	45	40	30	50	40	100	75	120	100	S811+R13N3S	
Frame Size T													
199	33	59	63	50	50	60	50	125	125	150	150	S811+T18N3S	
257	45	80	90	75	60	75	75	150	150	250	200	S811+T24N3S	
324	55	100	110	100	75	100	100	250	200	300	250	S811+T30N3S	
Frame Size U													
415	75	110	147	125	100	125	125	300	250	300	300	S811+U36N3S	
526	90	160	185	150	120	150	150	400	300	450	400	S811+U42N3S	
623	110	185	220	200	150	250	200	450	400	550	450	S811+U50N3S ②	
Frame Size V													
415	75	110	147	125	100	125	125	300	250	300	300	S811+V36N3S	
526	90	160	185	150	120	150	150	400	300	450	400	S811+V42N3S	
623	110	185	220	200	150	250	200	450	400	550	450	S811+V50N3S	
727	129	220	257	250	200	250	250	550	450	700	550	S811+V65N3S	
816	147	257	295	250	250	300	250	600	550	750	700	S811+V72N3S	
908	160	280	335	250	250	300	250	700	550	750	700	S811+V85N3S	
—	—	—	—	—	—	—	—	—	—	—	—	S811+V10N3S	

Notes

- ① Replace N3S with P3S for premium/pump option.
- ② S811+U50... unit does not have IEC certification.

Accessories

Lug Kits

S811+T..., S811U... and S811+V... soft starters each have different lug options based on your wiring needs. Each lug kit contains three lugs that can be mounted on either the load or line side.

Lug Kit



Lug Kits

S811+ Catalog Number	Description	Kits Required	Catalog Number
S811+T..., S811+U...	2 cable connections, 4 AWG to 1/0 cable	2	EML22
	1 cable connection, 4/0 to 500 kcmil cable		EML23
	2 cable connections, 4/0 to 500 kcmil cable		EML24
	1 cable connection, 2/0 to 300 kcmil cable		EML25
	2 cable connections, 2/0 to 300 kcmil cable		EML26
S811+V...	2 cable connections, 4/0 to 500 kcmil cable	2	EML28
	4 cable connections, 4/0 to 500 kcmil cable		EML30
	6 cable connections, 4/0 to 500 kcmil cable		EML32
	4 cable connections, 2/0 to 300 kcmil cable		EML33

Power Supplies

24 Vdc power supply that can be used with the S811+ SSRV or as a stand-alone device.

Power Supplies

Description	Catalog Number
85–264 Vac input 24 Vdc output	PSG240E
360–575 Vac input 24 Vdc output	PSG240F
600 Vac input 24 Vdc output	PSS55D

Lug Cover Kits

Replacement covers for the S811+T..., S811+U... and S811+V... soft starters are available in case of damage to the existing covers.

Lug Cover Kits

Description	Catalog Number
Lug cover S811+T..., S811+U...	EML27
Lug cover S811+V...	EML34

IP20 Kits

IP20 Kits

Description	Catalog Number
S811+N...	SS-IP20-N
S811+R...	SS-IP20-R
S811+T... and S811+U...	SS-IP20-TU
S811+V...	SS-IP20-V

Surge Suppressors

The surge suppressor can mount on either the line or load side of the soft starter. It is designed to clip the line voltage (or load side induced voltage).

Surge Suppressor



Surge Suppressors

Description	Catalog Number
600 V MOV for S811+... units	EMS39
690 V MOV for S811+... units [Ⓢ]	EMS41

Note

[Ⓢ] S811+T... only.

Mounting Plates

The mounting plates are designed to help make it easy to install or retrofit the soft starter into enclosures and MCCs. The soft starter can be mounted onto the plate prior to installation. The mounting plate is designed with tear drop mounting holes for easier installation.

Mounting Plates

Description	Catalog Number
S811+N...	EMM13N
S811+R...	EMM13R
S811+T... and S811+U...	EMM13T
S811+V...	EMM13V

Vibration Plates

The vibration plates allow the soft starter to be applied in high shock and vibration applications. The vibration plate allows vibration up to 5g and shock in up to 40g. The soft starter is mounted onto the vibration plate prior to installation in the panel.

Vibration Plates

Description	Catalog Number
S811+N...	EMM14N
S811+R...	EMM14R
S811+T... and S811+U...	EMM14T
S811+V...	EMM14V

Adapter Plates

The adapter plate allows customers to retrofit a S811+V... soft starter with the S811+U... soft starter.

Adapter Plates

Description	Catalog Number
Adapter plates	EMM13U

Control Wire Connector

Control Wire Connector

Description	Catalog Number
12-pin, 5 mm pitch connector for control wiring	EMA75

Digital Interface Module

The Digital Interface Module (DIM) is available as a replacement part.

DIM

Description	Catalog Number
Blank cover (filler)	EMA68
DIM for standard unit	EMA91
Panel mounting kit	
3 ft cable	EMA69A
5 ft cable	EMA69B
8 ft cable	EMA69C
10 ft cable	EMA69D

Options

S811+ Premium

In addition to what is already there in the S811+ standard, these devices offer pump control and extended ramp functions.

S811+ Premium

Current Range	Catalog Number
11–37	S811+N37P3S
20–66	S811+N66P3S
32–105	S811+R10P3S
42–135	S811+R13P3S
56–180	S811+T18P3S
75–240	S811+T24P3S
95–304	S811+T30P3S
112–360	S811+U36P3S
131–420	S811+U42P3S
156–500	S811+U50P3S ①
112–360	S811+V36P3S
131–420	S811+V42P3S
156–500	S811+V50P3S
203–650	S811+V65P3S
225–720	S811+V72P3S
265–850	S811+V85P3S
312–1000	S811+V10P3S

Note

① S811+U50... unit does not have IEC certification.

S811+ Premium 690 V Option

In addition to what is already there in S811+ standard, this product offers 690 V, pump control and extended ramp functions.

S811+ Premium 690 V Option

Current Range	Catalog Number
56–180	S811+T18V3S
75–240	S811+T24V3S
95–304	S811+T30 V3S
112–360	S811+V36V3S
131–420	S811+V42V3S
156–500	S811+V50 V3S
203–650	S811+V65V3S
225–720	S811+V72V3S
265–850	S811+V85V3S

Cooling Fan Kit

The EMM18 cooling fan kit mounts on either side of any frame size S811+ soft starter to provide additional printed circuit board cooling in high ambient operating temperatures.

Cooling Fan Kit

Description	Catalog Number
Fan kit	EMM18

Technical Data and Specifications

Soft Starters—S811+

Description	S811+N37...	S811+N66...	S811+R10+...	S811+R13...
Max. current capacity	37	66	105	135
FLA range	11–37	20–66	32–105	42–135
General Information				
Bypass mechanical lifespan	10M	10M	10M	10M
Insulating voltage U_i	660 V	660 V	660 V	660 V
Ramp time range	0.5–180 seconds (0.5–360 seconds S811+ Premium)	0.5–180 seconds (0.5–360 seconds S811+ Premium)	0.5–180 seconds (0.5–360 seconds S811+ Premium)	0.5–180 seconds (0.5–360 seconds S811+ Premium)
Resistance to vibration	3g	3g	3g	3g
Resistance to shock	15g	15g	15g	15g
Electrical Information				
Operating voltage	200–600 V	200–600 V	200–600 V	200–600 V
Operating frequency	47–63 Hz	47–63 Hz	47–63 Hz	47–63 Hz
Overload setting	30–100%	30–100%	30–100%	30–100%
Trip class	5, 10, 20 and 30	5, 10, 20 and 30	5, 10, 20 and 30	5, 10, 20 and 30
Cabling Capacity (IEC 947)				
Number of conductors	1	1	1	1
Wire sizes	14–2	14–2	14–4/0	14–4/0
Type of connectors	Box lug	Box lug	Box lug	Box lug
Control Wiring (12-Pin)				
Wire sizes in AWG	22–14	22–14	22–14	22–14
Number of conductors (stranded)	2 (or one AWG 12)	2 (or one AWG 12)	2 (or one AWG 12)	2 (or one AWG 12)
Torque requirements in lb-in	3.5	3.5	3.5	3.5
Solid, stranded or flexible max. size in mm ²	3.31	3.31	3.31	3.31
Control Power Requirements				
Voltage range (24V ±10%)	21.6–26.4	21.6–26.4	21.6–26.4	21.6–26.4
Steady-state current amps	1.0	1.0	1.0	1.0
Inrush current amps	10	10	10	10
Ripple	1%	1%	1%	1%
Relays (1) Class A and C				
Voltage AC—maximum	240	240	240	240
Voltage DC—maximum	120	120	120	120
Amps—maximum	3	3	3	3
Environment				
Temperature—operating	–30° to 50°C (no derating) consult factory for operation >50°C	–30° to 50°C (no derating) consult factory for operation >50°C	–30° to 50°C (no derating) consult factory for operation >50°C	–30° to 50°C (no derating) consult factory for operation >50°C
Temperature—storage	–50° to 70°C	–50° to 70°C	–50° to 70°C	–50° to 70°C
Altitude	<2000m—consult factory for operation >2000m	<2000m—consult factory for operation >2000m	<2000m—consult factory for operation >2000m	<2000m—consult factory for operation >2000m
Humidity	<95% noncondensing	<95% noncondensing	<95% noncondensing	<95% noncondensing
Operating position	Any	Any	Any	Any
Pollution degree IEC947-1	3	3	3	3
Impulse withstand voltage IEC947-4-1	6000 V	6000 V	6000 V	6000 V

Soft Starters—S811+, continued

Description	S811+T18...	S811+T24...	S811+T30...	S811+U36...
Max. current capacity	180	240	304	360
FLA range	56–180	75–240	95–304	112–360
General Information				
Bypass mechanical lifespan	10M	10M	10M	10M
Insulating voltage U_i	660 V	660 V	660 V	660 V
Ramp time range	0.5–180 seconds (0.5–360 seconds S811+ Premium)	0.5–180 seconds (0.5–360 seconds S811+ Premium)	0.5–180 seconds (0.5–360 seconds S811+ Premium)	0.5–180 seconds (0.5–360 seconds S811+ Premium)
Resistance to vibration	3g	3g	3g	3g
Resistance to shock	15g	15g	15g	15g
Electrical Information				
Operating voltage	200–600 V	200–600 V	200–600 V	200–600 V
Operating frequency	47–63 Hz	47–63 Hz	47–63 Hz	47–63 Hz
Overload setting	30–100%	30–100%	30–100%	30–100%
Trip class	5, 10, 20 and 30	5, 10, 20 and 30	5, 10, 20 and 30	5, 10, 20 and 30
Cabling Capacity (IEC 947)				
Number of conductors	1 or 2	1 or 2	1 or 2	1 or 2
Wire sizes	4 AWG to 500 kcmil	4 AWG to 500 kcmil	4 AWG to 500 kcmil	4 AWG to 500 kcmil
Type of connectors	Add-on lug kit	Add-on lug kit	Add-on lug kit	Add-on lug kit
Control Wiring (12-Pin)				
Wire sizes in AWG	22–14	22–14	22–14	22–14
Number of conductors (stranded)	2 (or one AWG 12)	2 (or one AWG 12)	2 (or one AWG 12)	2 (or one AWG 12)
Torque requirements in lb-in	3.5	3.5	3.5	3.5
Solid, stranded or flexible max. size in mm ²	3.31	3.31	3.31	3.31
Control Power Requirements				
Voltage range (24V ±10%)	21.6–26.4	21.6–26.4	21.6–26.4	21.6–26.4
Steady-state current amps	1.0	1.0	1.0	1.0
Inrush current amps	10	10	10	10
Ripple	1%	1%	1%	1%
Relays (1) Class A and C				
Voltage AC—maximum	240	240	240	240
Voltage DC—maximum	120	120	120	120
Amps—maximum	3	3	3	3
Environment				
Temperature—operating	–30° to 50°C (no derating) consult factory for operation >50°C	–30° to 50°C (no derating) consult factory for operation >50°C	–30° to 50°C (no derating) consult factory for operation >50°C	–30° to 50°C (no derating) consult factory for operation >50°C
Temperature—storage	–50° to 70°C	–50° to 70°C	–50° to 70°C	–50° to 70°C
Altitude	<2000m—consult factory for operation >2000m	<2000m—consult factory for operation >2000m	<2000m—consult factory for operation >2000m	<2000m—consult factory for operation >2000m
Humidity	<95% noncondensing	<95% noncondensing	<95% noncondensing	<95% noncondensing
Operating position	Any	Any	Any	Any
Pollution degree IEC947-1	3	3	3	3
Impulse withstand voltage IEC947-4-1	6000 V	6000 V	6000 V	6000 V

Soft Starters—S811+, continued

Description	S811+U42...	S811+U50... ^①	S811+V36...	S811+V42...
Max. current capacity	420	500	360	420
FLA range	131–420	156–500	112–360	131–420
General Information				
Bypass mechanical lifespan	10M	10M	10M	10M
Insulating voltage U _i	660 V	660 V	660 V	660 V
Ramp time range	0.5–180 seconds (0.5–360 seconds S811+ Premium)	0.5–180 seconds (0.5–360 seconds S811+ Premium)	0.5–180 seconds (0.5–360 seconds S811+ Premium)	0.5–180 seconds (0.5–360 seconds S811+ Premium)
Resistance to vibration	3g	3g	3g	3g
Resistance to shock	15g	15g	15g	15g
Electrical Information				
Operating voltage	200–600 V	200–600 V	200–600 V	200–600 V
Operating frequency	47–63 Hz	47–63 Hz	47–63 Hz	47–63 Hz
Overload setting	30–100%	30–100%	30–100%	30–100%
Trip class	5, 10, 20 and 30	5, 10, 20 and 30	5, 10, 20 and 30	5, 10, 20 and 30
Cabling Capacity (IEC 947)				
Number of conductors	1 or 2	1 or 2	2, 4 or 6	2, 4 or 6
Wire sizes	4 AWG to 500 kcmil	4 AWG to 500 kcmil	2/0 to 500 kcmil	2/0 to 500 kcmil
Type of connectors	Add-on lug kit	Add-on lug kit	Add-on lug kit	Add-on lug kit
Control Wiring (12-Pin)				
Wire sizes in AWG	22–14	22–14	22–14	22–14
Number of conductors (stranded)	2 (or one AWG 12)	2 (or one AWG 12)	2 (or one AWG 12)	2 (or one AWG 12)
Torque requirements in lb-in	3.5	3.5	3.5	3.5
Solid, stranded or flexible max. size in mm ²	3.31	3.31	3.31	3.31
Control Power Requirements				
Voltage range (24V ±10%)	21.6–26.4	21.6–26.4	21.6–26.4	21.6–26.4
Steady-state current amps	1.0	1.0	1.4	1.4
Inrush current amps	10	10	10	10
Ripple	1%	1%	1%	1%
Relays (1) Class A and C				
Voltage AC—maximum	240	240	240	240
Voltage DC—maximum	120	120	120	120
Amps—maximum	3	3	3	3
Environment				
Temperature—operating	–30° to 50°C (no derating) consult factory for operation >50°C	–30° to 50°C (no derating) consult factory for operation >50°C	–30° to 50°C (no derating) consult factory for operation >50°C	–30° to 50°C (no derating) consult factory for operation >50°C
Temperature—storage	–50° to 70°C	–50° to 70°C	–50° to 70°C	–50° to 70°C
Altitude	<2000m—consult factory for operation >2000m	<2000m—consult factory for operation >2000m	<2000m—consult factory for operation >2000m	<2000m—consult factory for operation >2000m
Humidity	<95% noncondensing	<95% noncondensing	<95% noncondensing	<95% noncondensing
Operating position	Any	Any	Any	Any
Pollution degree IEC947-1	3	3	3	3
Impulse withstand voltage IEC947-4-1	6000 V	6000 V	6000 V	6000 V

Note

① S811+U50... unit does not have IEC certification.

Soft Starters—S811+, continued

Description	S811+V50...	S811+V65...	S811+V72...	S811+V85...	S811+V10... ^①
Max. current capacity	500	650	720	850	1000
FLA range	156–500	203–650	225–720	265–580	320–1000
General Information					
Bypass mechanical lifespan	10M	10M	10M	10M	10M
Insulating voltage U _i	660 V	660 V	660 V	660 V	660 V
Ramp time range	0.5–180 seconds (0.5–360 seconds S811+ Premium)	0.5–180 seconds (0.5–360 seconds S811+ Premium)	0.5–180 seconds (0.5–360 seconds S811+ Premium)	0.5–180 seconds (0.5–360 seconds S811+ Premium)	0.5–180 seconds (0.5–360 seconds S811+ Premium)
Resistance to vibration	3g	3g	3g	3g	3g
Resistance to shock	15g	15g	15g	15g	15g
Electrical Information					
Operating voltage	200–600 V	200–600 V	200–600 V	200–600 V	200–600 V
Operating frequency	47–63 Hz	47–63 Hz	47–63 Hz	47–63 Hz	47–63 Hz
Overload setting	30–100%	30–100%	30–100%	30–100%	30–100%
Trip class	5, 10, 20 and 30	5, 10, 20 and 30	5, 10, 20 and 30	5, 10, 20 and 30	5, 10, 20 and 30
Cabling Capacity (IEC 947)					
Number of conductors	2, 4 or 6	2, 4 or 6	2, 4 or 6	2, 4 or 6	2, 4 or 6
Wire sizes	2/0 to 500 kcmil	2/0 to 500 kcmil	2/0 to 500 kcmil	2/0 to 500 kcmil	2/0 to 500 kcmil
Type of connectors	Add-on lug kit	Add-on lug kit	Add-on lug kit	Add-on lug kit	Add-on lug kit
Control Wiring (12-Pin)					
Wire sizes in AWG	22–14	22–14	22–14	22–14	22–14
Number of conductors (stranded)	2 (or one AWG 12)	2 (or one AWG 12)	2 (or one AWG 12)	2 (or one AWG 12)	2 (or one AWG 12)
Torque requirements in lb-in	3.5	3.5	3.5	3.5	3.5
Solid, stranded or flexible max. size in mm ²	3.31	3.31	3.31	3.31	3.31
Control Power Requirements					
Voltage range (24V ±10%)	21.6–26.4	21.6–26.4	21.6–26.4	21.6–26.4	21.6–26.4
Steady-state current amps	1.4	1.4	1.4	1.4	1.4
Inrush current amps	10	10	10	10	10
Ripple	1%	1%	1%	1%	1%
Relays (1) Class A and C					
Voltage AC—maximum	240	240	240	240	240
Voltage DC—maximum	120	120	120	120	120
Amps—maximum	3	3	3	3	3
Environment					
Temperature—operating	–30° to 50°C (no derating) consult factory for operation >50°C	–30° to 50°C (no derating) consult factory for operation >50°C	–30° to 50°C (no derating) consult factory for operation >50°C	–30° to 50°C (no derating) consult factory for operation >50°C	–30° to 50°C (no derating) consult factory for operation >50°C
Temperature—storage	–50° to 70°C	–50° to 70°C	–50° to 70°C	–50° to 70°C	–50° to 70°C
Altitude	<2000m—consult factory for operation >2000m	<2000m—consult factory for operation >2000m	<2000m—consult factory for operation >2000m	<2000m—consult factory for operation >2000m	<2000m—consult factory for operation >2000m
Humidity	<95% noncondensing	<95% noncondensing	<95% noncondensing	<95% noncondensing	<95% noncondensing
Operating position	Any	Any	Any	Any	Any
Pollution degree IEC947-1	3	3	3	3	3
Impulse withstand voltage IEC947-4-1	6000 V	6000 V	6000 V	6000 V	6000 V

Note

① UR recognized product.

1

Wiring Diagrams

Line Connected Soft Starter

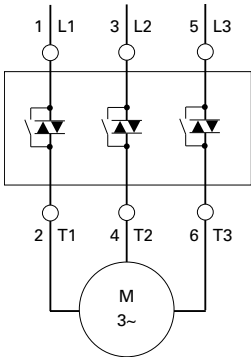

Inside-the-Delta Connected Soft Starter for a 6-Lead Motor

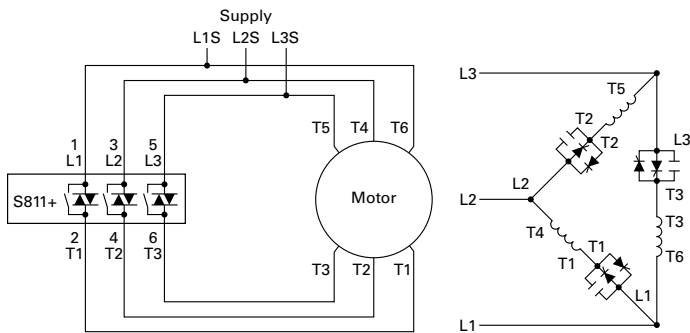

Inside-the-Delta Connected Soft Starter for a 12-Lead Low Voltage Motor

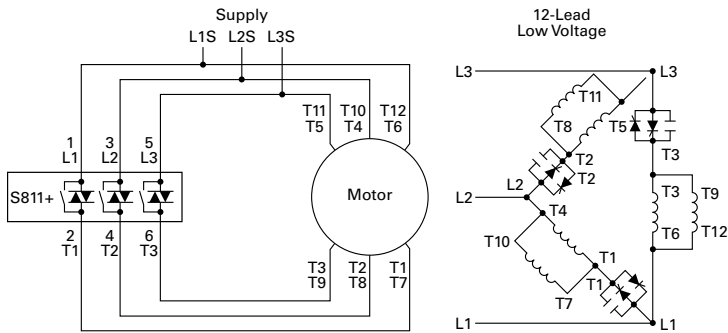

Inside-the-Delta Connected Soft Starter for a 12-Lead High Voltage Motor

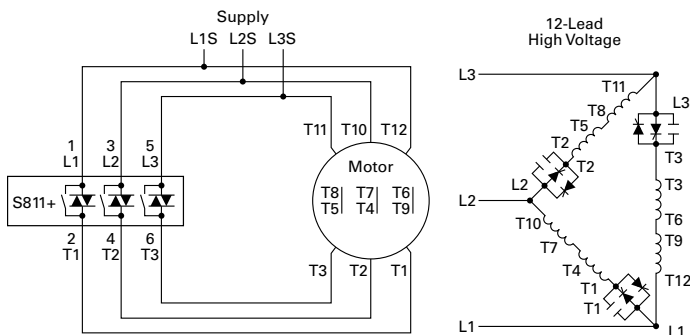

Dimensions

Approximate Dimensions in Inches (mm)

Soft Starters—S811+

Catalog Number ^①	W	H	D	Weight in Lbs (kg)
S811+N37N3S	2.66 (67.6)	7.37 (187.2)	6.45 (163.9)	5.8 (2.6)
S811+N66N3S	2.66 (67.6)	7.37 (187.2)	6.45 (163.9)	5.8 (2.6)
S811+R10N3S	4.38 (111.3)	7.92 (201.1)	6.64 (168.6)	10.5 (4.8)
S811+R13N3S	4.38 (111.3)	7.92 (201.1)	6.64 (168.6)	10.5 (4.8)
S811+T18N3S	7.65 (194.4)	12.71 (322.9)	6.47 (164.4)	48 (21.8) with lugs 41 (18.6) without lugs
S811+T24N3S	7.65 (194.4)	12.71 (322.9)	6.47 (164.4)	48 (21.8) with lugs 41 (18.6) without lugs
S811+T30N3S	7.65 (194.4)	12.71 (322.9)	6.47 (164.4)	48 (21.8) with lugs 41 (18.6) without lugs
S811+U36N3S	7.73 (196.3)	12.72 (323.1)	7.16 (181.8)	48 (21.8) with lugs 41 (18.6) without lugs
S811+U42N3S	7.73 (196.3)	12.72 (323.1)	7.16 (181.8)	48 (21.8) with lugs 41 (18.6) without lugs
S811+U50N3S	7.73 (196.3)	12.72 (323.1)	7.16 (181.8)	48 (21.8) with lugs 41 (18.6) without lugs
S811+V36N3S	11.05 (280.6)	16.57 (420.8)	7.39 (187.8)	103 (46.8) with lugs 91 (41.4) without lugs
S811+V42N3S	11.05 (280.6)	16.57 (420.8)	7.39 (187.8)	103 (46.8) with lugs 91 (41.4) without lugs
S811+V50N3S	11.05 (280.6)	16.57 (420.8)	7.39 (187.8)	103 (46.8) with lugs 91 (41.4) without lugs
S811+V65N3S	11.05 (280.6)	16.57 (420.8)	7.39 (187.8)	103 (46.8) with lugs 91 (41.4) without lugs
S811+V72N3S	11.05 (280.6)	16.57 (420.8)	7.39 (187.8)	103 (46.8) with lugs 91 (41.4) without lugs
S811+V85N3S	11.05 (280.6)	16.57 (420.8)	7.39 (187.8)	103 (46.8) with lugs 91 (41.4) without lugs
S811+V10N3S	11.05 (280.6)	16.57 (420.8)	7.39 (187.8)	103 (46.8) with lugs 91 (41.4) without lugs

Also refer to dimension drawings on **Pages V6-T1-96** through **V6-T1-98**.**Note**

① Dimensions of the frames stay consistent between the N3S, P3S, and V3S options.

1.2

Reduced Voltage Motor Starters

Solid-State Starters

1

Approximate Dimensions in Inches (mm)

S811+N...

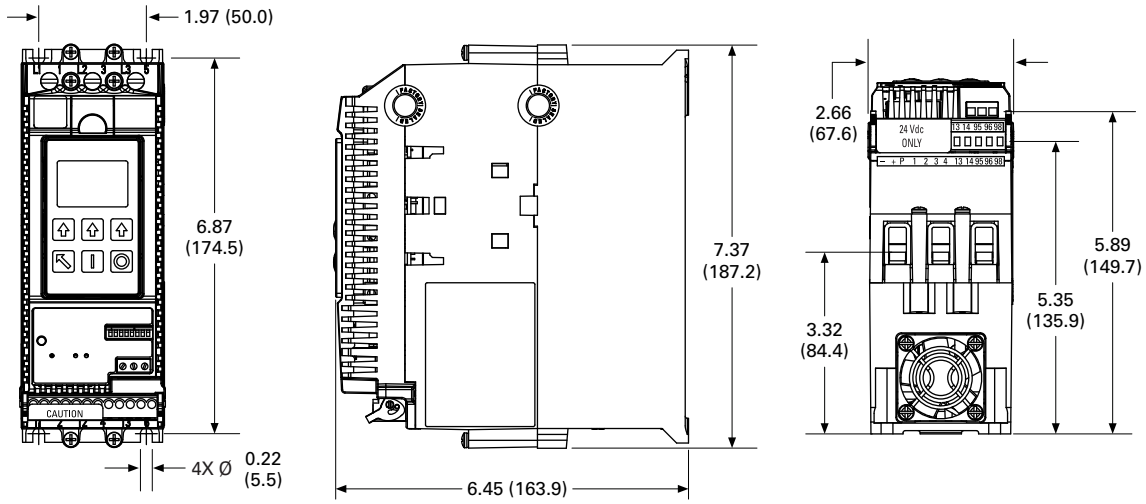

S811+R...

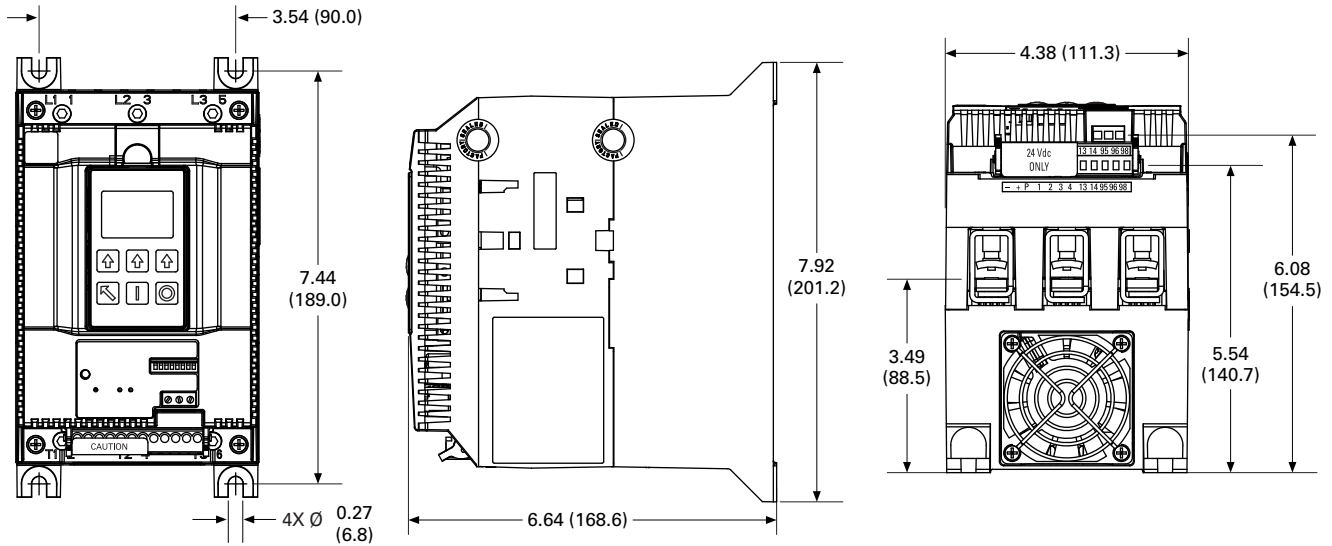

Approximate Dimensions in Inches (mm)

S811+T...

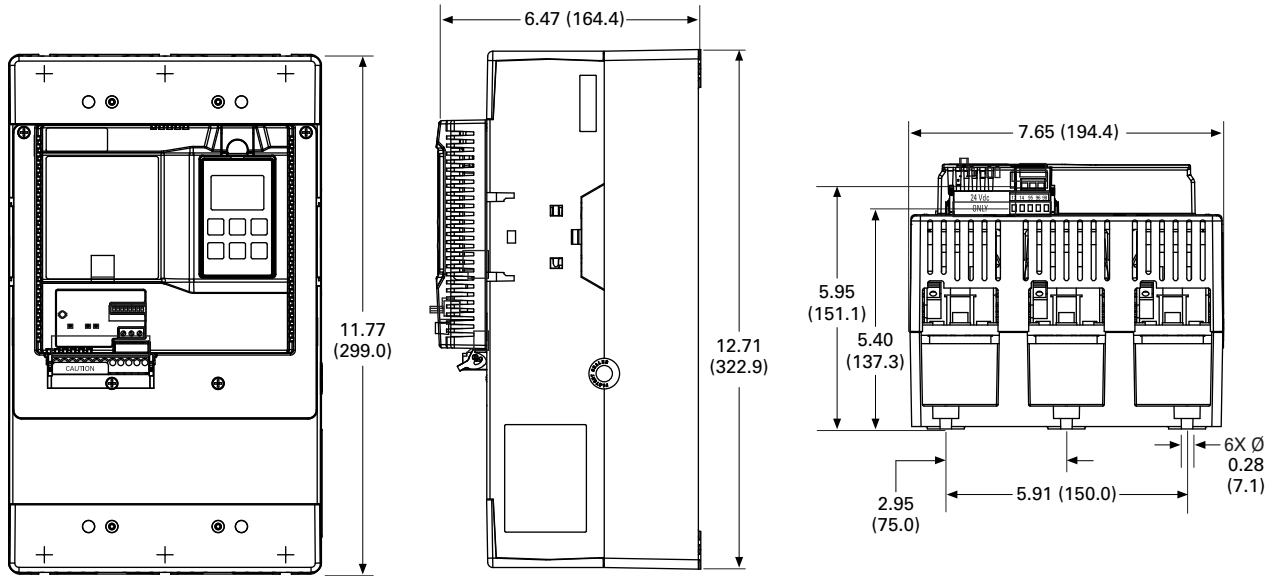

S811+U...

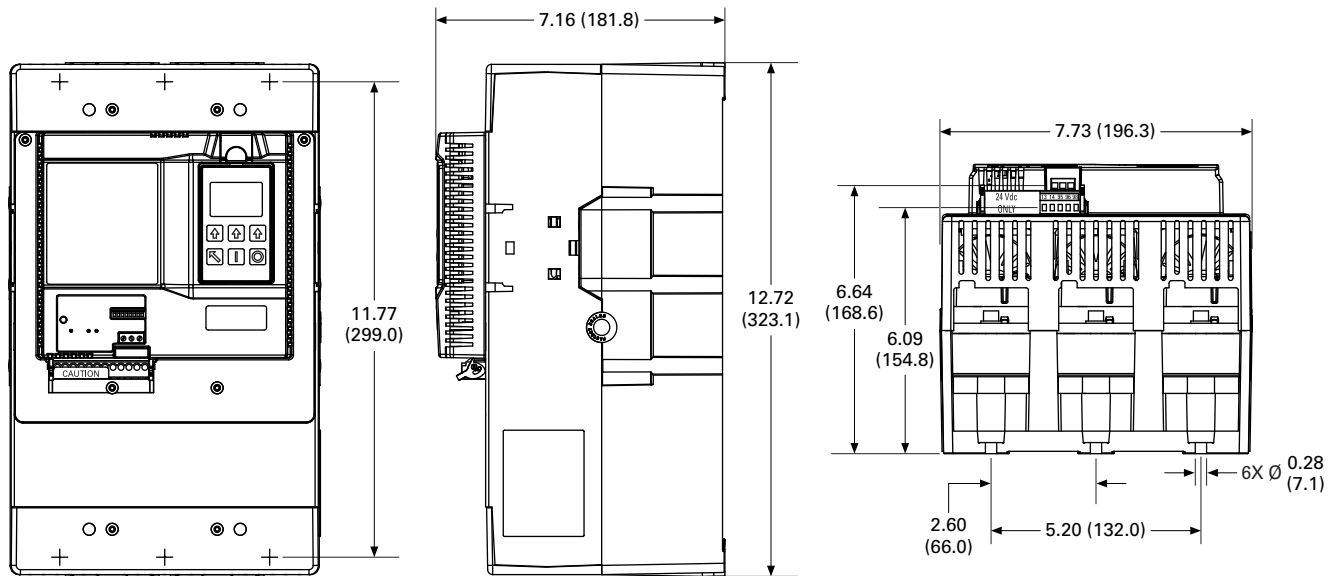

1.2

Reduced Voltage Motor Starters

Solid-State Starters

1

Approximate Dimensions in Inches (mm)

S811+V...

