

### Terminal Block Relays



### Contents

#### Description

#### Terminal Block Relays

Standard Terminal Block Relays .....	<b>V7-T3-4</b>
OptoCoupler Terminal Block Relays .....	<b>V7-T3-12</b>
High Current Terminal Block Relays .....	<b>V7-T3-15</b>
<b>XR</b> Series Accessories .....	<b>V7-T3-18</b>

#### Page

## Catalog Number Selection

### XR Series—Overview

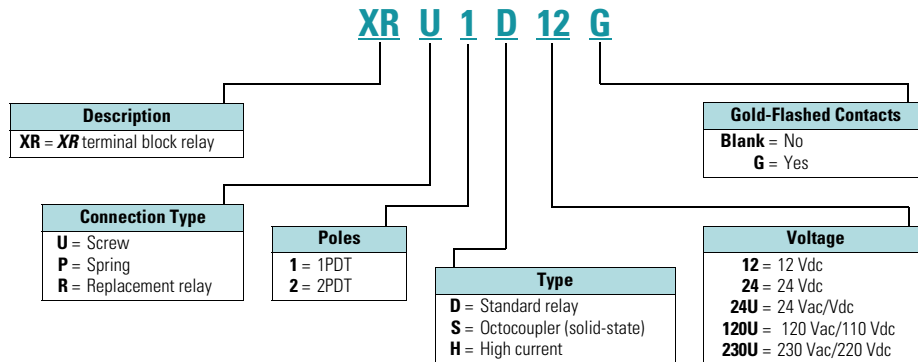

Standard Terminal Block Relay



### Contents

<b>Description</b>	<b>Page</b>
Standard Terminal Block Relays	
Product Selection .....	<b>V7-T3-5</b>
Technical Data and Specifications .....	<b>V7-T3-6</b>
Electrical Schematics .....	<b>V7-T3-11</b>
Dimensions .....	<b>V7-T3-11</b>
OptoCoupler Terminal Block Relays .....	<b>V7-T3-12</b>
High Current Terminal Block Relays .....	<b>V7-T3-15</b>
<b>XR</b> Series Accessories .....	<b>V7-T3-18</b>

### Standard Terminal Block Relays

#### Product Description

The **XR** Series Terminal Block Relays are ideal for applications that require a high switching capacity and long electrical service life. The relays are plug-in interfaces that connect to basic terminal blocks. The **XR** Series uses screw or spring-cage technology, as well as offers quick system wiring, superior safety features, clear labeling and a high level of modularity.

#### Application Description

Used in automation systems, electromechanical relays guarantee a safe connection between process I/O and electronic controls. The following functions are covered by relay coupling elements:

- Electrical isolation between the input and output circuits
- Independence of the type of switching current (AC and DC)
- High short-term overload resistance in the event of short circuits or voltage peaks
- Low switching losses
- Ease of operation

#### Features

- Pluggable relay allows for field replacement
- Functional plug-in bridges
- Choice of screw connections or spring-cage connection
- LED status indication
- DIN rail mount
- Only 6.2 mm wide for single-pole versions, 14 mm wide for double-pole
- All common input voltages between 12 Vdc to 120 Vac
- Gold-plated contacts available
- Equipped with a robust, miniature relay:
  - IP67 protection
  - Environmentally friendly, cadmium-free contact material
  - Easy, cost-effective installation and replacement using the engagement lever

#### Standards and Certifications

- cULus listed
- CE



## Product Selection

## XRU1D 24U



## Standard Terminal Block Relays

Gold-Plated Contacts	Rated Current	Supply Voltage	Standard Pack	Catalog Number
<b>1PDT Screw Connection</b>				
No	6A	12 Vdc	10	<b>XRU1D12</b>
No	6A	120 Vac/110 Vdc	10	<b>XRU1D120U</b>
Yes	6A	120 Vac/110 Vdc	10	<b>XRU1D120UG</b>
No	6A	24 Vdc	10	<b>XRU1D24</b>
No	6A	24 Vac/Vdc	10	<b>XRU1D24U</b>
Yes	6A	24 Vac/Vdc	10	<b>XRU1D24UG</b>
No	6A	230 Vac/220 Vdc	10	<b>XRU1D230U</b>
<b>1PDT Spring Cage Connection</b>				
No	6A	12 Vdc	10	<b>XRP1D12</b>
No	6A	120 Vac/110 Vdc	10	<b>XRP1D120U</b>
No	6A	24 Vdc	10	<b>XRP1D24</b>
No	6A	24 Vac/Vdc	10	<b>XRP1D24U</b>
No	6A	230 Vac/220 Vdc	10	<b>XRP1D230U</b>
<b>DPDT Screw Connection</b>				
No	6A	12 Vdc	10	<b>XRU2D12</b>
No	6A	120 Vac/110 Vdc	10	<b>XRU2D120U</b>
No	6A	24 Vdc	10	<b>XRU2D24</b>
No	6A	24 Vac/Vdc	10	<b>XRU2D24U</b>
No	6A	230 Vac/220 Vdc	10	<b>XRU2D230U</b>

## Standard Replacement Relays

Gold-Plated Contacts	Rated Current	Supply Voltage <sup>①</sup>	Standard Pack	Catalog Number
<b>1PDT</b>				
No	6A	12 Vdc	10	<b>XRR1D12</b>
No	6A	120 Vac/110 Vdc	10	<b>XRR1D120U</b>
Yes	6A	120 Vac/110 Vdc	10	<b>XRR1D120UG</b>
No	6A	24 Vdc	10	<b>XRR1D24</b>
Yes	6A	24 Vdc	10	<b>XRR1D24G</b>
<b>DPDT</b>				
No	6A	12 Vdc	10	<b>XRR2D12</b>
No	6A	120 Vac/110 Vdc	10	<b>XRR2D120U</b>
No	6A	24 Vdc	10	<b>XRR2D24</b>
No	6A	230 Vac/220 Vdc	10	<b>XRR2D230U</b>

**Note**

<sup>①</sup> Voltage is the rating at the base. It may not match the voltage on the specific replacement relay.

## Technical Data and Specifications

### Standard 1PDT Screw Connection Terminal Block Relays

Catalog Number	XRU1D12	XRU1D24	XRU1D24U	XRU1D120U
Replacement Relay	XRR1D12	XRR1D24	XRR1D24	XRR1D120U
Input voltage	12 Vdc	24 Vdc	24 Vac/Vdc	120 Vac/110 Vdc
<b>Connection Data</b>				
Rigid solid AWG (mm <sup>2</sup> )	26–14 (0.14–2.5)	26–14 (0.14–2.5)	26–14 (0.14–2.5)	26–14 (0.14–2.5)
Flexible stranded AWG (mm <sup>2</sup> )	26–14 (0.14–2.5)	26–14 (0.14–2.5)	26–14 (0.14–2.5)	26–14 (0.14–2.5)
<b>Input Data for 1PDT Screw Connection Versions</b>				
Input voltage	12 Vdc	24 Vdc	24 Vac/Vdc	120 Vac/110 Vdc
Permissible range	See <b>Page V7-T3-10</b>	See <b>Page V7-T3-10</b>	See <b>Page V7-T3-10</b>	See <b>Page V7-T3-10</b>
Typical input current	15.3 mA	9 mA	11 mA (24 Vac)/8.5 mA (24 Vdc)	3.5 mA (120 Vac)/3 mA (110 Vdc)
Typical response time	5 ms	5 ms	6 ms	6 ms
Typical release time	8 ms	8 ms	15 ms	15 ms
Input protection	Polarity protection diode, free-wheeling diode	Polarity protection diode, free-wheeling diode	Bridge rectifier	Bridge rectifier
<b>Output Data</b>				
Contact type	1PDT	1PDT	1PDT	1PDT
Contact material	AgSnO	AgSnO	AgSnO	AgSnO
Max. switching voltage	250 Vac/Vdc <sup>①</sup>	250 Vac/Vdc <sup>①</sup>	250 Vac/Vdc <sup>①</sup>	250 Vac/Vdc <sup>①</sup>
Min. switching voltage	12 Vac/Vdc	12 Vac/Vdc	12 Vac/Vdc	12 Vac/Vdc
Limiting continuous current	6A	6A	6A	6A
Min. switching current	10 mA	10 mA	10 mA	10 mA
Min. switching power	120 mW	120 mW	120 mW	120 mW
<b>Miscellaneous Data</b>				
Ambient temp range	–4° to 140°F (–20° to 60°C)	–4° to 140°F (–20° to 60°C)	–4° to 140°F (–20° to 60°C)	–4° to 140°F (–20° to 60°C)
Rated operating mode	100% operating factor	100% operating factor	100% operating factor	100% operating factor
Inflammability class	V0, in accordance with UL 94	V0, in accordance with UL 94	V0, in accordance with UL 94	V0, in accordance with UL 94
Mechanical service life	2 x 10 <sup>7</sup> cycles	2 x 10 <sup>7</sup> cycles	2 x 10 <sup>7</sup> cycles	2 x 10 <sup>7</sup> cycles

#### Note

<sup>①</sup> The separating plate, XRAPLCEsk, should be installed for voltages greater than 250V (L1, L2, L3) between identical terminal points of adjacent modules. Potential bridging is then possible with the XRAFBSST bridge system.

## Standard 1PDT Screw Connection Terminal Block Relays with Gold Contacts

Catalog Number	XRU1D24UG	XRU1D120UG
Replacement Relay	XRR1D24G	XRR1D120UG
Input voltage	24 Vac/Vdc	120 Vac/110 Vdc
<b>Connection Data</b>		
Rigid solid AWG (mm <sup>2</sup> )	26–14 (0.14–2.5)	26–14 (0.14–2.5)
Flexible stranded AWG (mm <sup>2</sup> )	26–14 (0.14–2.5)	26–14 (0.14–2.5)
<b>Input Data for 1PDT Screw Connection Versions with Gold Contacts</b>		
Input voltage	24 Vac/Vdc	120 Vac/110 Vdc
Permissible range	See <b>Page V7-T3-10</b>	See <b>Page V7-T3-10</b>
Typical input current	11 mA (24 Vac)/8.5 mA (24 Vdc)	3.5 mA (120 Vac)/3 mA (110 Vdc)
Typical response time	6 ms	6 ms
Typical release time	15 ms	15 ms
Input protection	Bridge rectifier	Bridge rectifier
<b>Output Data</b>		
Contact type	1PDT	1PDT
Contact material	AgSnO, gold plated <sup>①</sup>	AgSnO, gold plated <sup>①</sup>
Max. switching voltage	30 Vac/36 Vdc (250 Vac/Vdc) <sup>②</sup>	30 Vac/36 Vdc (250 Vac/Vdc) <sup>②</sup>
Min. switching voltage	100 mV (12 Vac/Vdc) <sup>②</sup>	100 mV (12 Vac/Vdc) <sup>②</sup>
Limiting continuous current	50 mA (6A) <sup>②</sup>	50 mA (6A) <sup>②</sup>
Min. switching current	1 mA (10 mA) <sup>②</sup>	1 mA (10 mA) <sup>②</sup>
Min. switching power	100 mW (120 mW) <sup>②</sup>	100 mW (120 mW) <sup>②</sup>
<b>Miscellaneous Data</b>		
Ambient temp range	–4° to 140°F (–20° to 60°C)	–40° to 131°F (–20° to 55°C)
Rated operating mode	100% operating factor	100% operating factor
Inflammability class	V0, in accordance with UL 94	V0, in accordance with UL 94
Mechanical service life	2 x 10 <sup>7</sup> cycles	2 x 10 <sup>7</sup> cycles

**Notes**

- <sup>①</sup> The separating plate, XRAPLCEsk, should be installed for voltages greater than 250V (L1, L2, L3) between identical terminal points of adjacent modules. Potential bridging is then possible with the XRAFBST bridge system.
- <sup>②</sup> If the maximum values are exceeded, the gold layer is destroyed and the values in parentheses apply.

## Standard 1PDT Spring Cage Terminal Block Relays

Catalog Number	XRP1D12	XRP1D24	XRP1D24U	XRP1D120U
Replacement Relay	XRR1D12	XRR1D24	XRR1D24	XRR1D120U
Input voltage	12 Vdc	24 Vdc	24 Vac/Vdc	120 Vac/110 Vdc
<b>Connection Data</b>				
Rigid solid AWG (mm <sup>2</sup> )	26–14 (0.14–2.5)	26–14 (0.14–2.5)	26–14 (0.14–2.5)	26–14 (0.14–2.5)
Flexible stranded AWG (mm <sup>2</sup> )	26–14 (0.14–2.5)	26–14 (0.14–2.5)	26–14 (0.14–2.5)	26–14 (0.14–2.5)
<b>Input Data for 1PDT Spring Cage Versions</b>				
Input voltage	12 Vdc	24 Vdc	24 Vac/Vdc	120 Vac/110 Vdc
Permissible range	See <b>Page V7-T3-10</b>	See <b>Page V7-T3-10</b>	See <b>Page V7-T3-10</b>	See <b>Page V7-T3-10</b>
Typical input current	15.3 mA	9 mA	11 mA (24 Vac)/8.5 mA (24 Vdc)	3.5 mA (120 Vac)/3 mA (110 Vdc)
Typical response time	5 ms	5 ms	6 ms	6 ms
Typical release time	8 ms	8 ms	15 ms	15 ms
Input protection	Polarity protection diode, free-wheeling diode	Polarity protection diode, free-wheeling diode	Bridge rectifier	Bridge rectifier
<b>Output Data</b>				
Contact type	1PDT	1PDT	1PDT	1PDT
Contact material	AgSnO	AgSnO	AgSnO	AgSnO
Max. switching voltage	250 Vac/Vdc <sup>①</sup>	250 Vac/Vdc <sup>①</sup>	250 Vac/Vdc <sup>①</sup>	250 Vac/Vdc <sup>①</sup>
Min. switching voltage	12 Vac/Vdc	12 Vac/Vdc	12 Vac/Vdc	12 Vac/Vdc
Limiting continuous current	6A	6A	6A	6A
Min. switching current	10 mA	10 mA	10 mA	10 mA
Min. switching power	120 mW	120 mW	120 mW	120 mW
<b>Miscellaneous Data</b>				
Ambient temp range	–4° to 140°F (–20° to 60°C)	–4° to 140°F (–20° to 60°C)	–4° to 140°F (–20° to 60°C)	–4° to 131°F (–20° to 55°C)
Rated operating mode	100% operating factor	100% operating factor	100% operating factor	100% operating factor
Inflammability class	V0, in accordance with UL 94	V0, in accordance with UL 94	V0, in accordance with UL 94	V0, in accordance with UL 94
Mechanical service life	2 x 10 <sup>7</sup> cycles	2 x 10 <sup>7</sup> cycles	2 x 10 <sup>7</sup> cycles	2 x 10 <sup>7</sup> cycles

**Note**

<sup>①</sup> The separating plate, XRAPLCEsk, should be installed for voltages greater than 250V (L1, L2, L3) between identical terminal points of adjacent modules. Potential bridging is then possible with the XRAFBSST bridge system.

## Standard DPDT Screw Connection Terminal Block Relays

Catalog Number Replacement Relay	XRU2D12 XRR2D12	XRU2D24 XRR2D24	XRU2D24U XRR2D24	XRU2D120U XRR2D120U
Input voltage	12 Vdc	24 Vdc	24 Vac/Vdc	120 Vac/110 Vdc
<b>Connection Data</b>				
Rigid solid AWG (mm <sup>2</sup> )	26–14 (0.14–2.5)	26–14 (0.14–2.5)	26–14 (0.14–2.5)	26–14 (0.14–2.5)
Flexible stranded AWG (mm <sup>2</sup> )	26–14 (0.14–2.5)	26–14 (0.14–2.5)	26–14 (0.14–2.5)	26–14 (0.14–2.5)
<b>Input Data for 1PDT Spring Cage Versions</b>				
Input voltage	12 Vdc	24 Vdc	24 Vac/Vdc	120 Vac/110 Vdc
Permissible range	See <b>Page V7-T3-10</b>	See <b>Page V7-T3-10</b>	See <b>Page V7-T3-10</b>	See <b>Page V7-T3-10</b>
Typical input current	33 mA	18 mA	17.5 mA	4.5 mA (120 Vac)/4.2 mA (110 Vdc)
Typical response time	8 ms	8 ms	8 ms	7 ms
Typical release time	10 ms	10 ms	10 ms	10 ms
Input protection	Polarity protection diode, free-wheeling diode	Polarity protection diode, free-wheeling diode	Bridge rectifier	Bridge rectifier
<b>Output Data</b>				
Contact type	2PDT	Single contact, 2PDT	Single contact, 2PDT	Single contact, 2PDT
Contact material	AgNi	AgNi	AgNi	AgNi
Max. switching voltage	250 Vac/Vdc <sup>①</sup>	250 Vac/Vdc <sup>①</sup>	250 Vac/Vdc <sup>①</sup>	250 Vac/Vdc <sup>①</sup>
Min. switching voltage	5V	5V	5V	5V
Limiting continuous current	6A	6A	6A	6A
Max. inrush current	15A (300 ms)	15A (300 ms)	15A (300 ms)	15A (300 ms)
Min. switching current	10 mA	10 mA	10 mA	10 mA
Min. switching power	50 mW	50 mW	50 mW	50 mW
<b>General Data</b>				
Ambient temp range	–4° to 140°F (–20° to 60°C)	–4° to 140°F (–20° to 60°C)	–4° to 140°F (–20° to 60°C)	–4° to 140°F (–20° to 60°C)
Rated operating mode	100% operating factor	100% operating factor	100% operating factor	100% operating factor
Inflammability class	V0, in accordance with UL 94	V0, in accordance with UL 94	V0, in accordance with UL 94	V0, in accordance with UL 94
Mechanical service life	3 x 10 <sup>7</sup> cycles	3 x 10 <sup>7</sup> cycles	3 x 10 <sup>7</sup> cycles	3 x 10 <sup>7</sup> cycles

**Note**

<sup>①</sup> The separating plate, XRAPLCEsk, should be installed for voltages greater than 250V (L1, L2, L3) between identical terminal points of adjacent modules. Potential bridging is then possible with the XRFBST bridge system.

# 3.2

## Control Relays and Timers

### Terminal Block Relays

#### Permissible Range Diagrams

1PDT Relay Modules

#### Operating Range Voltage for 12 Vdc

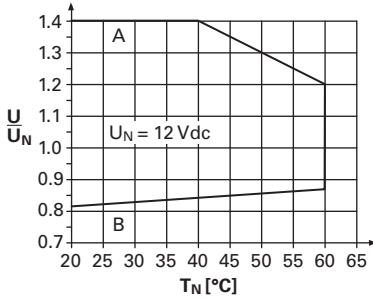

DPDT Relay Modules

#### Operating Range Voltage for 12 Vdc

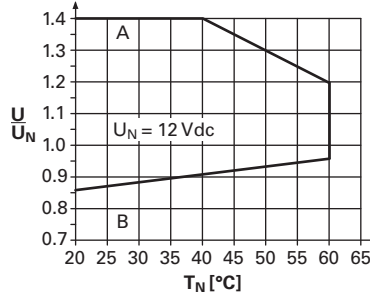

#### Operating Range Voltage for 120 Vac/110 Vdc

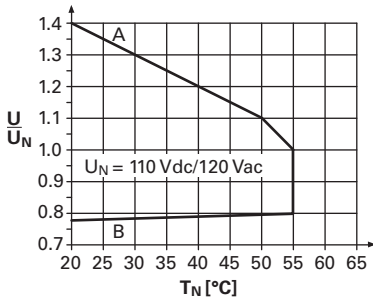

#### Operating Range Voltage for 120 Vac/110 Vdc

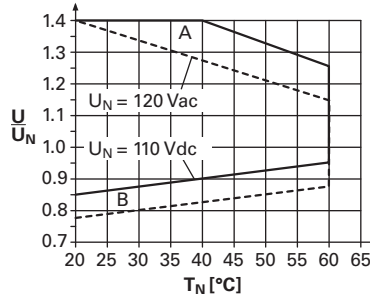

#### Operating Range Voltage for 24 Vdc

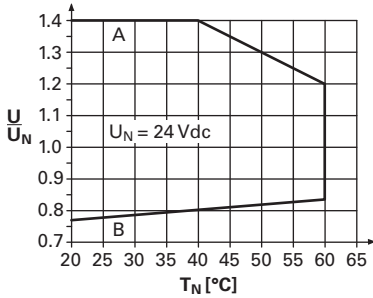

#### Operating Range Voltage for 24 Vdc

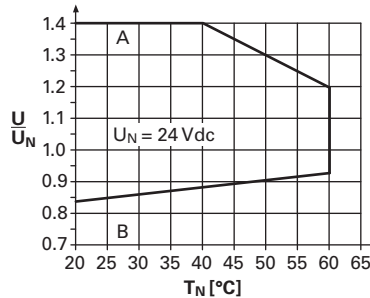

#### Operating Range Voltage for 24 Vac/Vdc

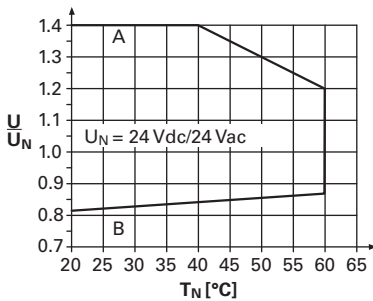

#### Operating Range Voltage for 24 Vac/Vdc

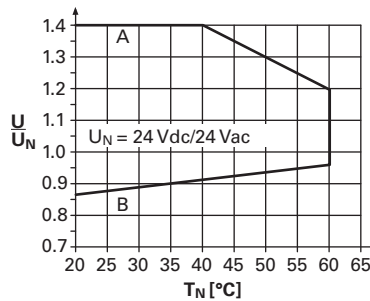

#### Notes

**General Conditions** — Direct alignment in the block, all devices 100% operating factor, horizontal or vertical mounting.

**Curve A** — Maximum permissible continuous operating voltage  $U_{max}$  with limiting continuous current on the contact side (see respective technical data).

**Curve B** — Minimum permissible relay operate voltage  $U_{op}$  after pre-excitation <sup>①</sup> (see respective technical data).

<sup>①</sup> Pre-excitation: Relay has been operated in a thermally steady state at the ambient temperature  $T_U$  with nominal voltage  $U_N$  and limiting continuous current on the contact side (see respective technical data) (warm coil). After being switched off for a short time, the relay must reliably pick up again at  $U_{op}$ .



### Electrical Schematics

#### 1PDT Terminal Block Relays

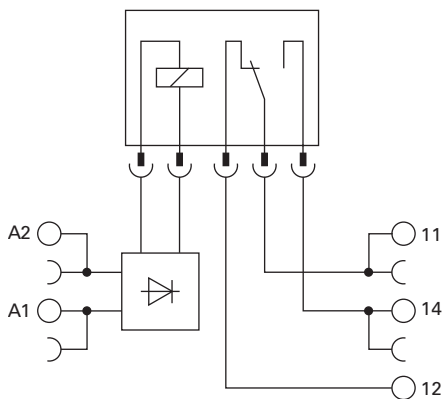

#### DPDT Terminal Block Relays

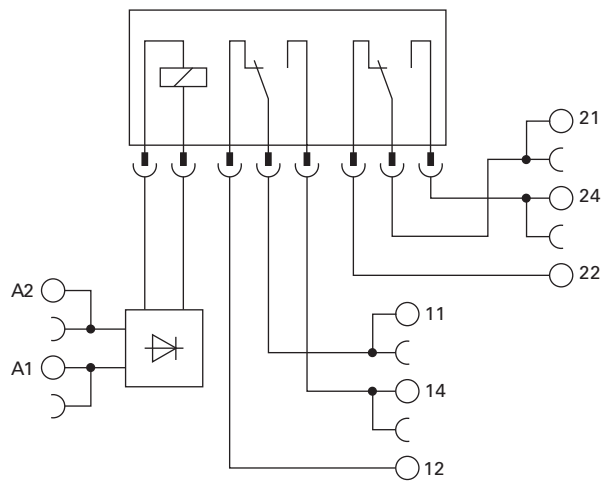

### Dimensions

Approximate Dimensions in Inches (mm)

#### Standard 1PDT Terminal Block Relays

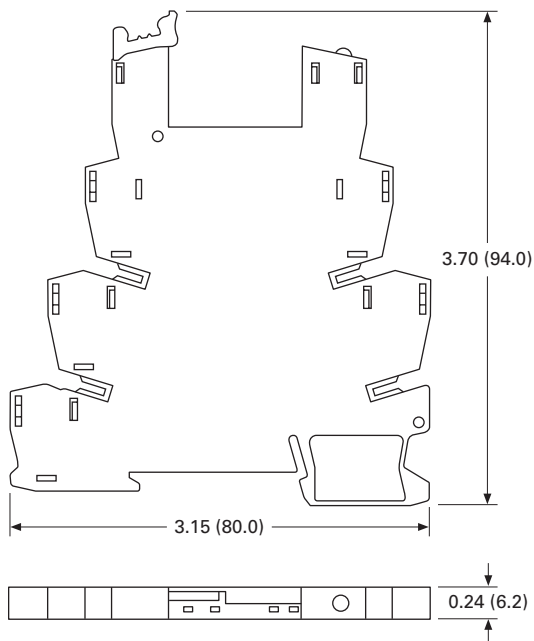

#### Standard DPDT Terminal Block Relays

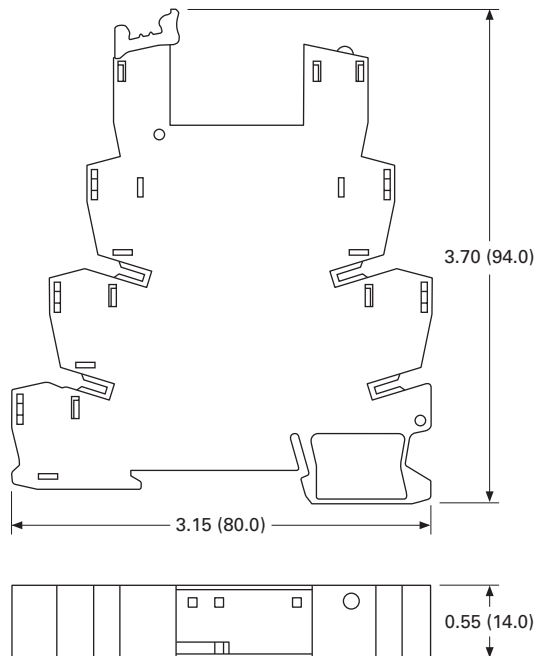

OptoCoupler Terminal Block Relay



3

### Contents

<b>Description</b>	<b>Page</b>
Standard Terminal Block Relays . . . . .	<b>V7-T3-4</b>
OptoCoupler Terminal Block Relays	
Product Selection . . . . .	<b>V7-T3-13</b>
Technical Data and Specifications . . . . .	<b>V7-T3-13</b>
Electrical Schematic . . . . .	<b>V7-T3-14</b>
Dimensions . . . . .	<b>V7-T3-14</b>
High Current Terminal Block Relays . . . . .	<b>V7-T3-15</b>
<b>XR</b> Series Accessories . . . . .	<b>V7-T3-18</b>

### OptoCoupler Terminal Block Relays

#### Product Description

The **XR** Series OptoCoupler Terminal Block Relays can be used in all applications and consist of a pluggable miniature OptoCoupler and a basic terminal block. The **XR** Series uses screw or spring-cage technology, as well as offers quick system wiring, superior safety features, clear labeling and a high level of modularity.

#### Application Description

The **XR** Series OptoCoupler relays can be used as an input or output interface. They provide the typical reliability of OptoCouplers and are especially suited for high operating frequencies.

#### Features

- Pluggable relay allows for field replacement
- Functional plug-in bridges
- LED status indication
- DIN rail mount
- Only 6.2 mm wide
- Switching capacity up to 24 Vdc/3A
- IP67-protected optical electronics
- Wear-resistant and bounce-free switching
- Insensitive to shock and vibration
- Integrated protection circuit
- Zero voltage switch at AC output

#### Standards and Certifications

- cULus listed
- CE



## Product Selection

## XRU1S24



## OptoCoupler Terminal Block Relays

Rated Current	Supply Voltage	Standard Pack	Catalog Number
2A	120 Vac/110 Vdc	10	XRU1S120U
2A	24 Vdc	10	XRU1S24

## OptoCoupler Replacement Relays

Rated Current	Supply Voltage <sup>①</sup>	Standard Pack	Catalog Number
2A	24 Vdc	18	XRR1S24
2A	120 Vac/110 Vdc	10	XRR1S120U

## Technical Data and Specifications

## Pluggable Power OptoCoupler (Solid-State) Terminal Block Relays

Catalog Number	XRU1S24	XRU1S120U
Replacement Relay	XRR1S24	XRR1S120U
Input voltage	24 Vdc	120 Vac/110 Vdc
<b>Connection Data</b>		
Rigid solid AWG (mm <sup>2</sup> )	26–14 (0.14–2.5)	26–14 (0.14–2.5)
Flexible stranded AWG (mm <sup>2</sup> )	26–14 (0.14–2.5)	26–14 (0.14–2.5)
<b>Input Data</b>		
Input voltage	24 Vdc	120 Vac/110 Vdc
Permissible range	0.8–1.2	0.8–1.1
Typical input current	9 mA	4 mA
Switching level 1 signal ("H")	≥0.8	≥0.8
Switching level 0 signal ("L")	≤0.4	≤0.25
Typical switch-on time	20 μS	6 ms
Typical turn-off time	500 μS	10 ms
Input protection	Polarity protection diode, free-wheeling diode	Bridge rectifier
<b>Output Data</b>		
Max. switching voltage	33 Vdc	33 Vdc
Min. switching voltage	3 Vdc	3 Vdc
Limiting continuous current	3A (See derating curve)	3A (See derating curve)
Max. inrush current	15A (10 ms)	15A (10 ms)
Output circuit	2-conductor floating	2-conductor floating
Output protection	Polarity protection, surge protection	Polarity protection, surge protection
Voltage drop at maximum limiting continuous current	≤ 200 mV	≤ 200 mV
<b>General Data</b>		
Ambient temp range	–4° to 140°F (–20° to 60°C)	–4° to 140°F (–20° to 60°C)
Rated operating mode	100% operating factor	100% operating factor
Inflammability class	V0, in accordance with UL 94	V0, in accordance with UL 94
Mechanical service life	2 x 10 <sup>7</sup> cycles	2 x 10 <sup>7</sup> cycles

**Note**

<sup>①</sup> Voltage is the rating at the base. It may not match the voltage on the specific replacement relay.

# 3.2

## Control Relays and Timers

### Terminal Block Relays

3

#### Derating Curve OptoCoupler

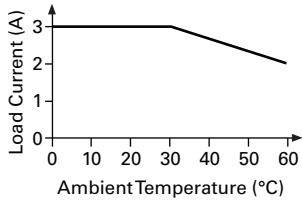

#### Electrical Schematic

##### Pluggable Power OptoCoupler (Solid-State) Terminal Block Relays

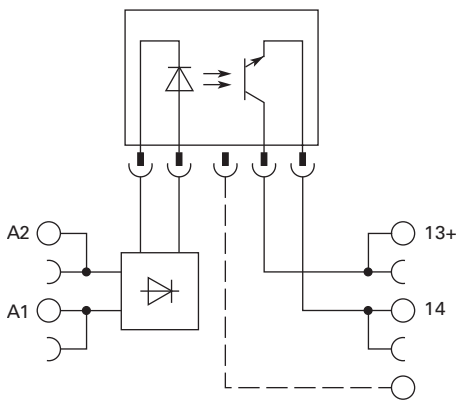

#### Dimensions

Approximate Dimensions in Inches (mm)

##### Pluggable Power OptoCoupler (Solid-State) Terminal Block Relays

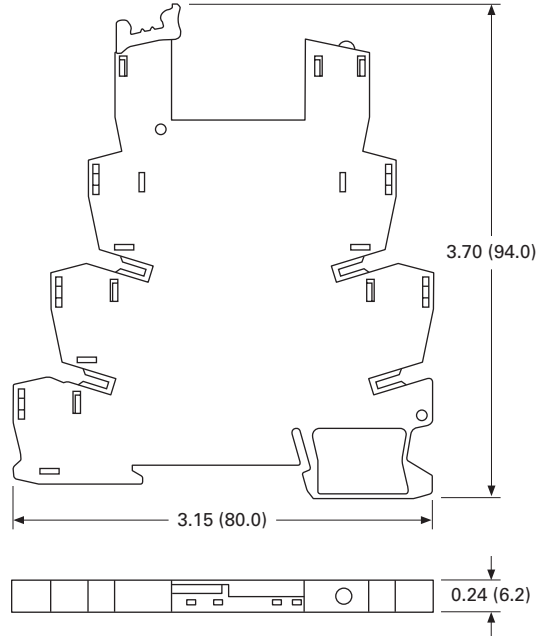

## High Current Terminal Block Relay



## Contents

<b>Description</b>	<b>Page</b>
Standard Terminal Block Relays . . . . .	V7-T3-4
OptoCoupler Terminal Block Relays . . . . .	V7-T3-12
High Current Terminal Block Relays	
Product Selection . . . . .	V7-T3-16
Technical Data and Specifications . . . . .	V7-T3-16
Electrical Schematic . . . . .	V7-T3-17
Dimensions . . . . .	V7-T3-17
<b>XR Series Accessories</b> . . . . .	<b>V7-T3-18</b>

## High Current Terminal Block Relays

## Product Description

The **XR** Series Relays include products designed to meet high continuous current and/or long electrical service life applications. The **XR** Series Relays are plug-in interfaces that connect to basic terminal blocks that use screw connection technology. Overall width is 14 mm.

## Application Description

These relays are best suited for applications that require higher continuous load currents than miniature relays can carry and switch. They can withstand inrush currents or brief overloads without damage, and allow for continuous load currents of up to 10A. The **XR** Series Relay boasts an average service life of the contacts that is two or three times the normal life of a less powerful relay, resulting in service cost savings.

## Features

- 14 mm wide
- Pluggable relay allows for field replacement
- Convenient plug-in bridge system
- LED status indication
- DIN Rail Mount
- IP67-protected optical electronics
- Wear-resistant and bounce-free switching
- Insensitive to shock and vibration
- Integrated protection circuit
- Zero voltage switch at AC output
- Environmentally friendly, cadmium-free contact material
- Electrical isolation between input and output

## Standards and Certifications

- cULus listed
- CE



## Product Selection

## XRU1H24



## High Current Terminal Block Relays

Rated Current	Supply Voltage	Standard Pack	Catalog Number
10A	12 Vdc	10	XRU1H12
10A	120 Vac/110 Vdc	10	XRU1H120U
10A	24 Vdc	10	XRU1H24
10A	24 Vac/Vdc	10	XRU1H24U

## High Current Replacement Relays

Rated Current	Supply Voltage <sup>①</sup>	Standard Pack	Catalog Number
10A	24 Vdc	10	XRR1H24
10A	24 Vac/Vdc	10	XRR1H24U
10A	12 Vdc	10	XRR1H12
10A	120 Vac/110 Vdc	10	XRR1H120U

## Technical Data and Specifications

## High Current Terminal Block Relays (1PDT)

Catalog Number Replacement Relay	XRU1H12 XRR1H12	XRU1H24 XRR1H24	XRU1H24U XRR1H24U	XRU1H120U XRR1H120U
Input voltage	12 Vdc	24 Vdc	24 Vac/Vdc	120 Vac/110 Vdc
<b>Connection Data</b>				
Rigid solid AWG (mm <sup>2</sup> )	26–14 (0.14–2.5)	26–14 (0.14–2.5)	26–14 (0.14–2.5)	26–14 (0.14–2.5)
Flexible stranded AWG (mm <sup>2</sup> )	26–14 (0.14–2.5)	26–14 (0.14–2.5)	26–14 (0.14–2.5)	26–14 (0.14–2.5)
<b>Input Data for 1PDT Spring Cage Versions</b>				
Input voltage	12 Vdc	24 Vdc	24 Vac/Vdc	120 Vac/110 Vdc
Permissible range	See <b>Page V7-T3-10</b>	See <b>Page V7-T3-10</b>	See <b>Page V7-T3-10</b>	See <b>Page V7-T3-10</b>
Typical input current	33 mA	18 mA	17.5 mA	4.5 mA (120 Vac)/4.2 mA (110 Vdc)
Typical response time	8 ms	8 ms	8 ms	7 ms
Typical release time	10 ms	10 ms	10 ms	10 ms
Input protection	Polarity protection diode, free-wheeling diode	Polarity protection diode, free-wheeling diode	Bridge rectifier	Bridge rectifier
<b>Output Data</b>				
Contact type	Single contact, 1PDT	Single contact, 1PDT	Single contact, 1PDT	Single contact, 1PDT
Contact material	AgNi	AgNi	AgNi	AgNi
Max. switching voltage	250 Vac/Vdc <sup>②</sup>	250 Vac/Vdc <sup>②</sup>	250 Vac/Vdc <sup>②</sup>	250 Vac/Vdc <sup>②</sup>
Min. switching voltage	12 Vac/Vdc	12 Vac/Vdc	12 Vac/Vdc	12 Vac/Vdc
Limiting continuous current	10A <sup>③</sup>	10A <sup>③</sup>	10A <sup>③</sup>	10A <sup>③</sup>
Max. inrush current	30A (300 ms)	30A (300 ms)	30A (300 ms)	30A (300 ms)
Min. switching current	100 mA	100 mA	100 mA	100 mA
Min. switching power	1.2W	1.2W	1.2W	1.2W
<b>Miscellaneous Data</b>				
Ambient temp range	–4° to 140°F (–20° to 60°C)	–4° to 140°F (–20° to 60°C)	–4° to 140°F (–20° to 60°C)	–4° to 140°F (–20° to 60°C)
Rated operating mode	100% operating factor	100% operating factor	100% operating factor	100% operating factor
Inflammability class	V0, in accordance with UL 94	V0, in accordance with UL 94	V0, in accordance with UL 94	V0, in accordance with UL 94
Mechanical service life	3 x 10 <sup>7</sup> cycles	3 x 10 <sup>7</sup> cycles	3 x 10 <sup>7</sup> cycles	3 x 10 <sup>7</sup> cycles

## Notes

- <sup>①</sup> Voltage is the rating at the base. It may not match the voltage on the specific replacement relay.
- <sup>②</sup> The separating plate, XRAPLCEsk, should be installed for voltages greater than 250V (L1, L2, L3) between identical terminal points of adjacent modules. Potential bridging is then possible with the XRAFBST bridge system.
- <sup>③</sup> The current rating for the normally open contact (#14) is 10A. The current rating for the normally closed contact (#12) is 6A and can be increased to 10A by bridging the two #12 contact connections.

### Electrical Schematic

#### High Current Terminal Block Relays

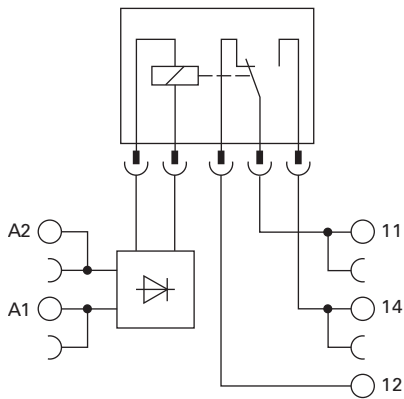

### Dimensions

Approximate Dimensions in Inches (mm)

#### High Current Terminal Block Relays

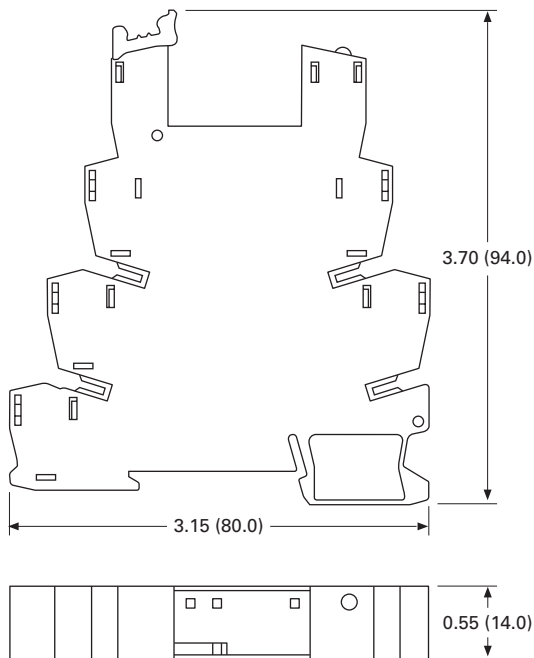

## XR Series Accessories

### Product Description

#### Power Terminal Block

#### Bridges



The XRAPLCESK power terminal block has the same shape as the relay modules and is used to feed in the bridging potentials. The nominal current is 32A. When the total current is less than or equal to 6A, supply can take place directly at the connecting terminal blocks of one of the connected relays.

#### End Cover

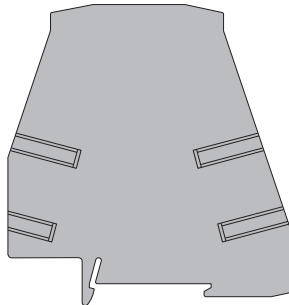

The XRAATPBK end cover is required at the start and stop of a relay strip. It can also be used for visual separation of groups of relays as well as separating relays with voltages greater than 250V and separating neighboring bridges with different potentials. It is equipped with pre-scored break out points at the bridging positions so that individual bridges can be passed through as needed. It may also be necessary to use the end cover between adjacent relays when three phases (L1, L2, L3) are used on the contact side of the relay.

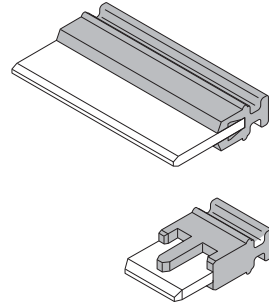

The XRAFBST colored, insulated plug-in bridge system reduces wiring time by up to 70% compared to conventionally wired relays. The XRAFBST2, 2-position bridges, are suited for bridging a smaller number of relays and total currents  $\leq 6A$ . When a circuit is supplied from both sides, the circuit can be opened at any point, allowing all other modules to continue being supplied at the same time. The XRAFBST500 allow up to 80 modules to be bridged at one time. If bridges with different potentials meet in neighboring modules, the end cover XRAATPBK should be used. All bridges are equipped with a groove for removal with a standard screwdriver.

### Product Selection

#### XR Series Accessories

Color	Standard Pack	Catalog Number
<b>2-Position Snap-In Jumper</b>		
Red	10	XRAFBST2RD
Blue	10	XRAFBST2BU
Gray	10	XRAFBST2GY
<b>80-Position Snap-In Jumper</b>		
Red	5	XRAFBST500RD
Blue	5	XRAFBST500BU
Gray	5	XRAFBST500GY
<b>Power Terminal Block</b>		
Gray	5	XRAPLCESK
<b>End Cover</b>		
Black	5	XRAATPBK

### Technical Data and Specifications

#### Power Terminal Block

Description	Specification
<b>Connection Data</b>	
Rigid solid AWG (mm <sup>2</sup> )	24–10 (0.2–4)
Flexible stranded AWG (mm <sup>2</sup> )	24–10 (0.2–4)
<b>Miscellaneous Data</b>	
Max. current	32A
Max. voltage	250 Vac <sup>①</sup>

#### Note

- <sup>①</sup> The separating plate, XRAPLCESK, should be installed for voltages greater than 250V (L1, L2, L3) between identical terminal points of adjacent modules. Potential bridging is then possible with the XRAFBST bridge system.