

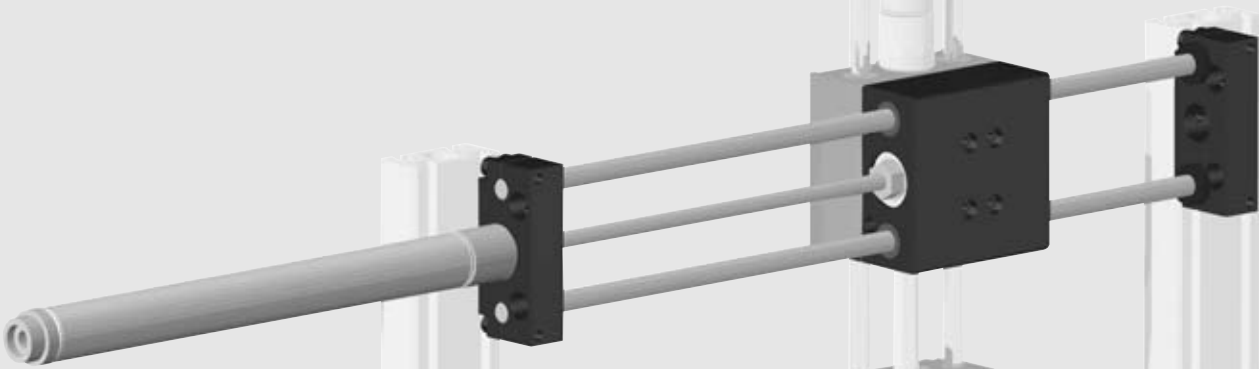

Externally Powered Base Slides



DLB SERIES

4.20

Cylinder options:

Externally powered base slides are available in a wide range of cylinder options. Choose from replaceable/disposable, replaceable with adjustable cushions, NFPA with adjustable cushions, ISO/Metric, VDMA, locking VDMA, or non-powered for use with customer supplied cylinders.

DIRECTCONNECT mounting patterns:

These slides have DIRECTCONNECT mounting patterns that connect to other slides without the need for adapter plates.

Mounting Information:

Mounts and operates in any orientation

Payload attaches to tapped holes in body with screws and locates using slip fit dowel pin holes

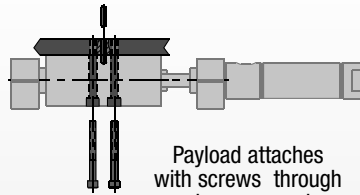
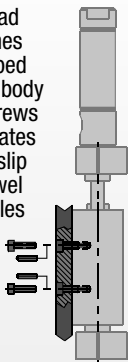

Payload attaches with screws through clearance and counterbored holes in body and locates using slip fit dowel pin holes

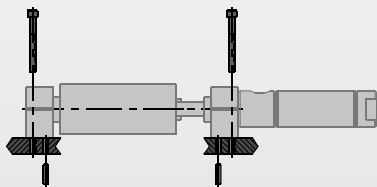

End blocks mount with screws and locate with slip fit dowel pin holes

Technical Specifications:

Pneumatic Specifications

Pressure Operating Range*
Cylinder Type
Dynamic Seals
Valve Required to Operate

Imperial	Metric
40-100 psi	3-7 bar
Double Acting	
Internally Lubricated Buna-N	
4-way, 2-position	

Air Quality Requirements

Air Filtration
Air Lubrication
Air Humidity

40 Micron or Better
Not Necessary**
Low Moisture Content (dry)

Temperature Operating Range

Buna-N Seals (standard)
Viton Seals (optional)

-30°~180° F	-35°~80° C
-20°~300° F	-30°~150° C

Maintenance Specifications†

Expected Life
Normal Application
w/ Preventative Maintenance
Field Repairable
Seal Repair Kits Available

5 million cycles
10+ million cycles†
No
No

Application Restrictions

Flow controls, shock absorbers and urethane bumpers recommended for nearly all applications.
Use composite bushing in dirty or gritty environments.
Never use silicone based lubricants with composite bushings.

*Higher pressure possible. Consult factory with application details.

**Addition of lubrication will greatly increase service life

†See Maintenance Section

DIRECTCONNECT™

Product Features

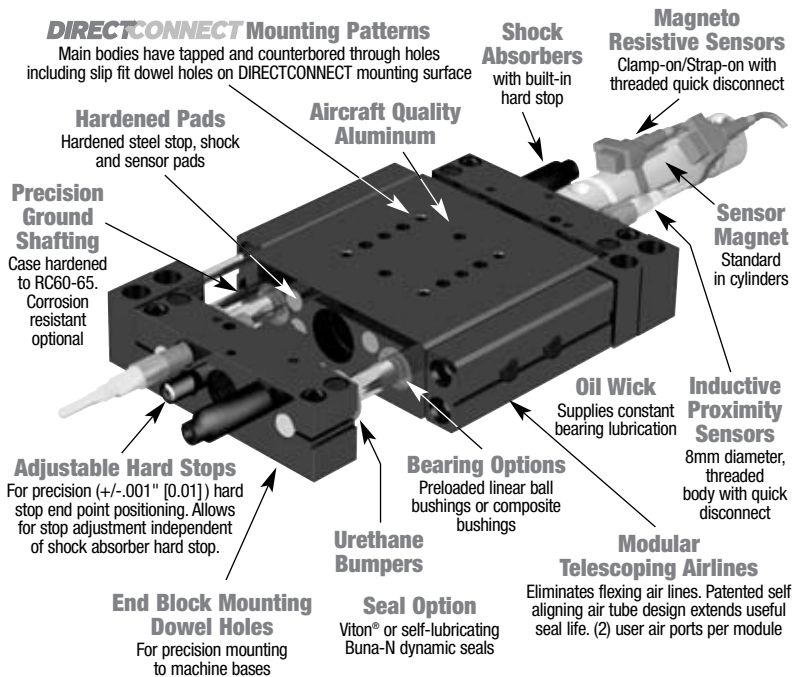

Operating Principle

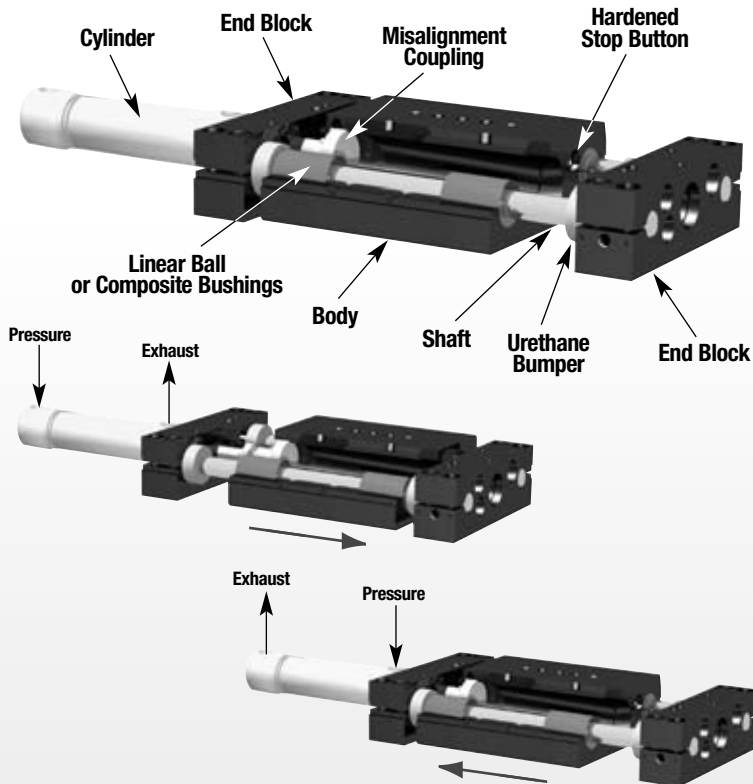

- A moveable body is supported by four linear bushings which slide on two hardened steel shafts.
- The shafts are supported on each end of the slide by two fixed end blocks.
- A double acting air cylinder is mounted to one of the end blocks.
- The piston rod of the cylinder is connected to the slide body with a misalignment coupling.
- When air pressure is applied to the cylinder the slide body moves.

Designed and manufactured in the USA

Style-T, A Replaceable Cyl.

-10M (Metric -A only) (shown)
-12M (Metric -A only)
-16M (Metric -A only)

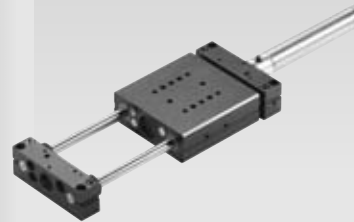

See Page **4.22**

Style-T, A Replaceable Cyl.

Size -20 (shown)
-25

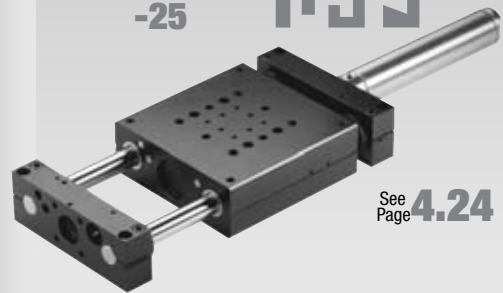

See Page **4.24**

Style-N, U Repairable Cyl.

Size -10 (shown)
-12
-16

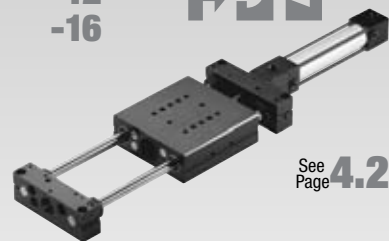

See Page **4.26**

Style-N, R, U Repairable Cyl.

Size -20M (shown)
-25M

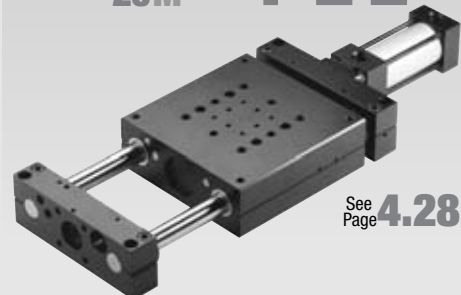

See Page **4.28**



DLB SERIES

4.21



DIRECTCONNECT™



BASE SLIDE DLB -10M, 12M, 16M -T, A REPLACEABLE CYLINDER WITH OR W/O ADJUST. AIR CUSHIONS

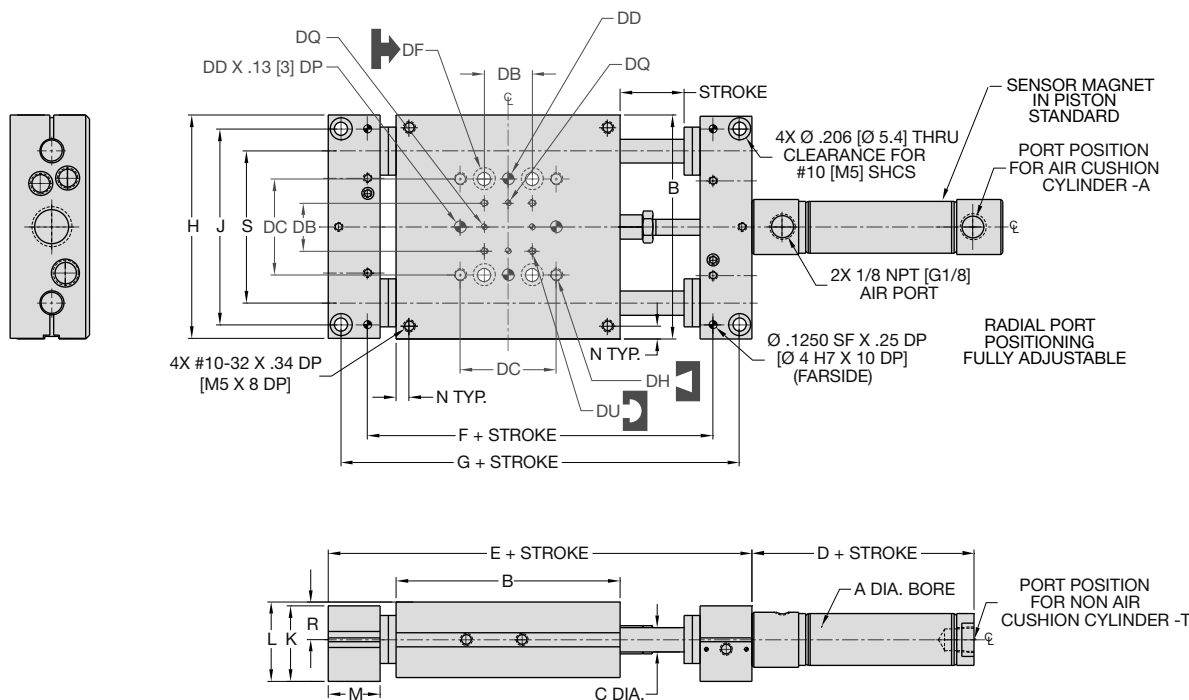

UNLESS OTHERWISE NOTED ALL TOLERANCES ARE AS SHOWN BELOW

				Imperial in.	Metric [mm]
Dimensions are symmetrical about centerline	Third Angle Projection	All Dowel Holes are SF (Slip Fit). Locational Tolerance ±.0005" or ±.013mm	Metric Threads Course Pitch	0.00 ± .01 0.000 ± .005 0.0000 ± .0005	[.] = ±.25 [0.] = ±.13 [0.00] = ±.013

DIRECTCONNECT DIMENSIONS STANDARD MOUNTING PATTERN FOR ALL SIZES

	Imperial (inches)	Metric (mm)
DB	.750	19.1
DC	1.500	38.1
DD	.1880 x .25 DP	5mm H7 x 6 DP
DF	Clearance for #10	Clearance for M5
DH	#10-32 x .34 DP	M5 x 8.5 DP
DQ	.0940 x .078 DP	3H7 x 2 DP
DU	#4-40 X .25 DP	M3 X 6 DP

MODEL #	BORE DIA.		SHAFT DIA.												
	A	B	C	D	E	F	G	H	J	K	L	M	N	R	S
DLB-10	3/4	3.50	.375	2.91	5.63	4.3975	5.228	3.485	3.060	1.178	1.245	.813	N/A	.594	2.375
DLB-12	1 1/16	4.00	.472	2.88	6.13	4.8975	5.728	3.985	3.500	1.615	1.657	.813	.375	.813	2.750
DLB-16	1 1/16	4.75	.630	2.88	6.88	5.6475	6.478	4.735	4.250	1.615	1.657	.813	.375	.813	3.250
DLB-10M	20	88.9	9.5	88.0	149.4	118.05	139.1	88.5	77.7	29.9	31.6	20.7	N/A	15.09	60.33
DLB-12M	25	101.6	12	91.5	162.1	130.75	151.8	101.2	88.9	41.0	42.1	20.7	9.5	20.65	69.85
DLB-16M	25	120.7	16	91.5	181.1	149.80	170.9	120.3	107.9	41.0	42.1	20.7	9.5	20.65	82.55

How to Order: Basic Unit

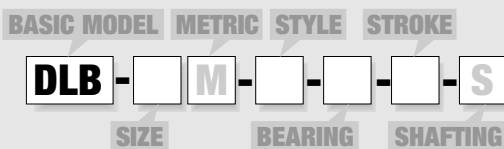

- SIZE** 10, 12, 16
- METRIC** M
- STYLE** T Replaceable cylinder w/o adjustable air cushions (Not avail. in metric)
A Replaceable cylinder with adjustable air cushions
- BEARING** B Linear ball bearings
C Composite bushings
- STROKE** (inches)
DLB-10 1-12 @ 1" increments
DLB-12 1-16 @ 1" increments
DLB-16 1-20 @ 1" increments
- STROKE** (mm)
DLB-10M 25, 50, 80, 100, 125, 160, 200, 250, 300
DLB-12M 25, 50, 80, 100, 125, 160, 200, 250, 300, 320, 360, 400
DLB-16M 25, 50, 80, 100, 125, 160, 200, 250, 300, 320, 360, 400, 500
- SHAFTING** S Corrosion resistant shafting
- Custom strokes available. Please consult factory.

SAMPLE ORDER: DLB-10M-A-B-25

Ex: Base Slide, Size 10 Metric, Replaceable Cylinder w/Adjustable Air Cushions, Linear Ball Bushings, 25mm Stroke

Accessories:

(Order Separately) DLB-10M DLB-12M DLB-16M QTY/SLIDE

SHOCK/STOP ACCESSORIES

Shock Absorber	SHOK-028	SHOK-010	SHOK-010	1 or 2
Adjustable Hard Stop	DLT-1023	DLT-1023	DLT-1023	1 or 2

INDUCTIVE SENSOR ACCESSORIES †

Inductive Sensor PNP Qk. Disconnect	OISP-011	OISP-011	OISP-011	1 or 2
Inductive Sensor NPN Qk. Disconnect	OISN-011	OISN-011	OISN-011	1 or 2
Quick. Disconnect 2M Cable Length	CABL-010	CABL-010	CABL-010	1 or 2
Quick. Disconnect 5M Cable Length	CABL-013	CABL-013	CABL-013	1 or 2

MAGNETIC SENSOR ACCESSORIES †**

Magneto Resistive Sensor PNP Qk. Disc.	OHSP-005	OHSP-005	OHSP-005	1 or 2
Magneto Resistive Sensor NPN Qk. Disc.	OHSN-005	OHSN-005	OHSN-005	1 or 2
Quick. Disconnect 2M Cable Length	CABL-010	CABL-010	CABL-010	1 or 2
Quick. Disconnect 5M Cable Length	CABL-013	CABL-013	CABL-013	1 or 2

PNEUMATIC ACCESSORIES

1/8 NPT Telescopic Airlines (up to 6")	OTAL-039	OTAL-039	OTAL-039	1,2,3 or 4
1/8 NPT Telescopic Airlines (up to 12")	OTAL-040	OTAL-040	OTAL-040	1,2,3 or 4
1/8 NPT Telescopic Airlines (up to 18")	OTAL-041	OTAL-041	OTAL-041	1,2,3 or 4
1/8 NPT Telescopic Airlines (up to 24")	OTAL-042	OTAL-042	OTAL-042	1,2,3 or 4
1/8 NPT Adjustable Flow Control	VLVF-004	VLVF-004	VLVF-004	1 or 2
G1/8 Telescopic Airlines (up to 160mm)	OTAL-045	OTAL-045	OTAL-045	1,2,3 or 4
G1/8 Telescopic Airlines (up to 300mm)	OTAL-046	OTAL-046	OTAL-046	1,2,3 or 4
G1/8 Telescopic Airlines (up to 450mm)	OTAL-047	OTAL-047	OTAL-047	1,2,3 or 4
G1/8 Telescopic Airlines (up to 600mm)	OTAL-048	OTAL-048	OTAL-048	1,2,3 or 4
G1/8 Adjustable Flow Control	VLVF-005	VLVF-005	VLVF-005	1 or 2

†Sensor and cable sold separately **Piston magnet standard

Please see back cover for DE-STA-CO Global Locations. www.destaco.com

www.comoso.com

DIRECTCONNECT™

DLB SERIES

4.22



BASE SLIDE DLB -10M, 12M, 16M -T, A REPLACEABLE CYLINDER WITH OR W/O ADJUST. AIR CUSHIONS



DLB SERIES

4.23

DIRECTCONNECT™

DLB-10M-T,A,U

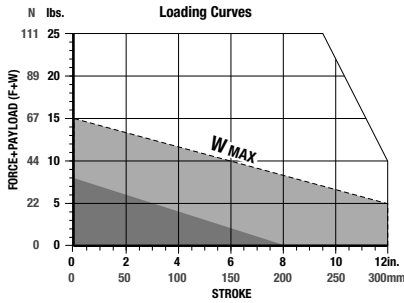

DLB-12M-T,A,U

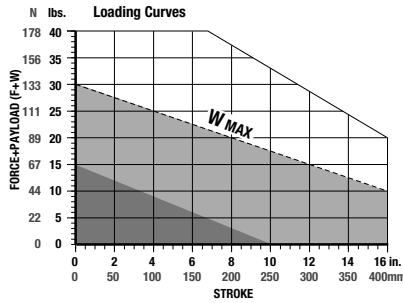

DLB-16M-T,A,U

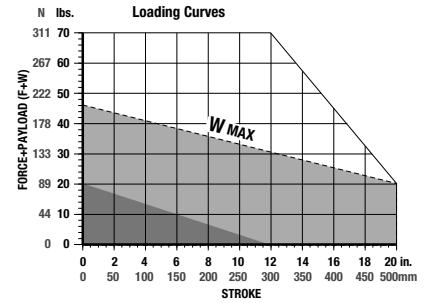

F=Externally applied force (lbs. or N)
W=Weight of payload (lbs. or N)
F+W=Total force (lbs. or N)

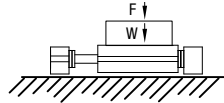

Shock Absorbers and Flow Controls are recommended for nearly all applications

(W) in this range use **Single Shock** in both directions

(W) in this range use **Bumpers or Cushioned Cylinder**

Shaded shock absorption ranges of horizontal payload (W) @ 80psi, flow controls fully open. For vertical applications do not exceed 1/2 of the recommended payload due to the additional acceleration effect of gravity.

Specifications	DLB-10	DLB-10M
Maximum Air Pressure.....	100 psi	6.9 bar
Thrust Force @ 80psi/5.5bar .	31 lbs.	145 N
Weight (Basic Unit -T, -A).....	1.98 lbs.	0.90 kg
Additional Weight per Stroke ..	0.09 lbs./in.	1.4 g/mm
Cylinder Bore Diameter	3/4"	20 mm
Shaft Diameter	0.375"	9.5 mm
Maximum Moment Load	75 in.-lbs.	8.4 N-m

Specifications	DLB-12	DLB-12M
Maximum Air Pressure.....	100 psi	6.9 bar
Thrust Force @ 80psi/5.5bar .	65 lbs.	289 N
Weight (Basic Unit -T, -A).....	3.73 lbs.	1.66 kg
Additional Weight per Stroke ..	0.15 lbs./in.	2.9 g/mm
Cylinder Bore Diameter	1-1/16"	25 mm
Shaft Diameter	0.472"	12 mm
Maximum Moment Load	150 in.-lbs.	16.9 N-m

Specifications	DLB-16	DLB-16M
Maximum Air Pressure.....	100 psi	6.9 bar
Thrust Force @ 80psi/5.5bar .	65 lbs.	289 N
Weight (Basic Unit -T, -A).....	5.03 lbs.	2.3 kg
Additional Weight per Stroke ..	0.23 lbs./in.	4.2 g/mm
Cylinder Bore Diameter	1-1/16"	25 mm
Shaft Diameter	0.630"	16 mm
Maximum Moment Load	300 in.-lbs.	33.9 N-m

Accessory Mounting Technical Data

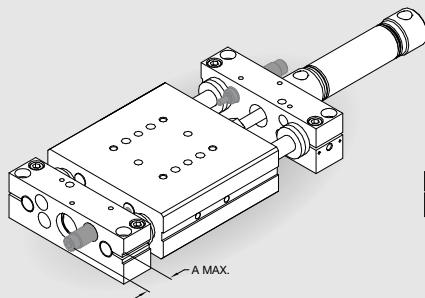

Shock Absorbers

- Full stroking piston rod
- Built-in hard stop
- Allen wrench adjustable

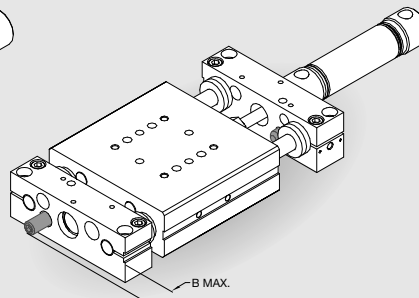

Adjustable Hard Stops

- For precision (+/- .001") hard stop end point positioning
- Allows for stop adjustment independent of shock absorber hard stop
- Allen wrench adjustable

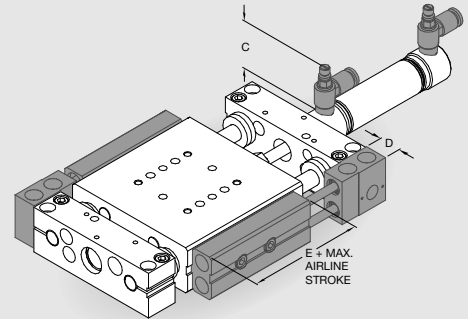

Telescoping Airlines

- Eliminate flexing air lines
- Self aligning air tube design extends useful seal life
- Modular stackable design. Up to (4) modules can be stacked
- Modules can be mounted on either side of slide
- 1/8 NPT or G1/8 pipe threads
- (2) user air ports per module

Flow Controls for Cylinders

- Thumb screw adjust with locking nut for adjusting cylinder speed
- 1/8 NPT or G1/8 pipe threads

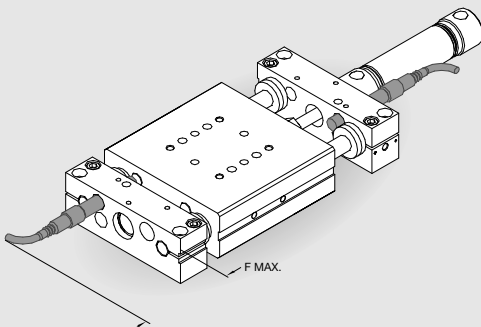

Inductive Proximity Sensors

- 8mm diameter
- Threaded quick disconnect with built-in LED output
- PNP and NPN available

Quick Disconnect Cable

- Threaded coupling with knurled head for secure electrical connections
- 2 meter cable length
- 5 meter cable length

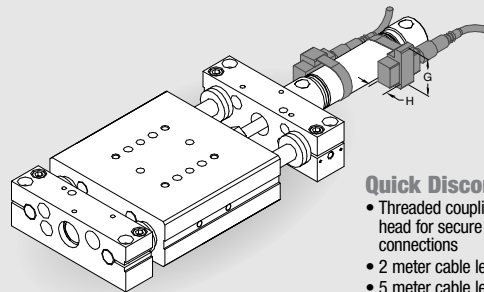

Magneto Resistive Sensors

- For all externally mounted cylinders
- Quick Disconnect with built in LED output
- Strap-on mounting kit included
- PNP and NPN available

Quick Disconnect Cable

- Threaded coupling with knurled head for secure electrical connections
- 2 meter cable length
- 5 meter cable length

	A	B	C	D	E	F	G	H
DLB-10	.70"	.47	1.25	.577	3.60	2.5	1.00	.43
DLB-12	.95"	.47	1.25	.577	3.60	2.5	1.00	.43
DLB-16	.95"	.47	1.25	.577	3.60	2.5	1.00	.43
DLB-10M	17.8mm	11.9	31.8	14.7	91.4	63.5	25.4	10.9
DLB-12M	24.1mm	11.9	31.8	14.7	91.4	63.5	25.4	10.9
DLB-16M	24.1mm	11.9	31.8	14.7	91.4	63.5	25.4	10.9

BASE SLIDE DLB -20, 25 -T, A REPLACEABLE CYLINDER WITH OR W/O ADJUST. AIR CUSHIONS

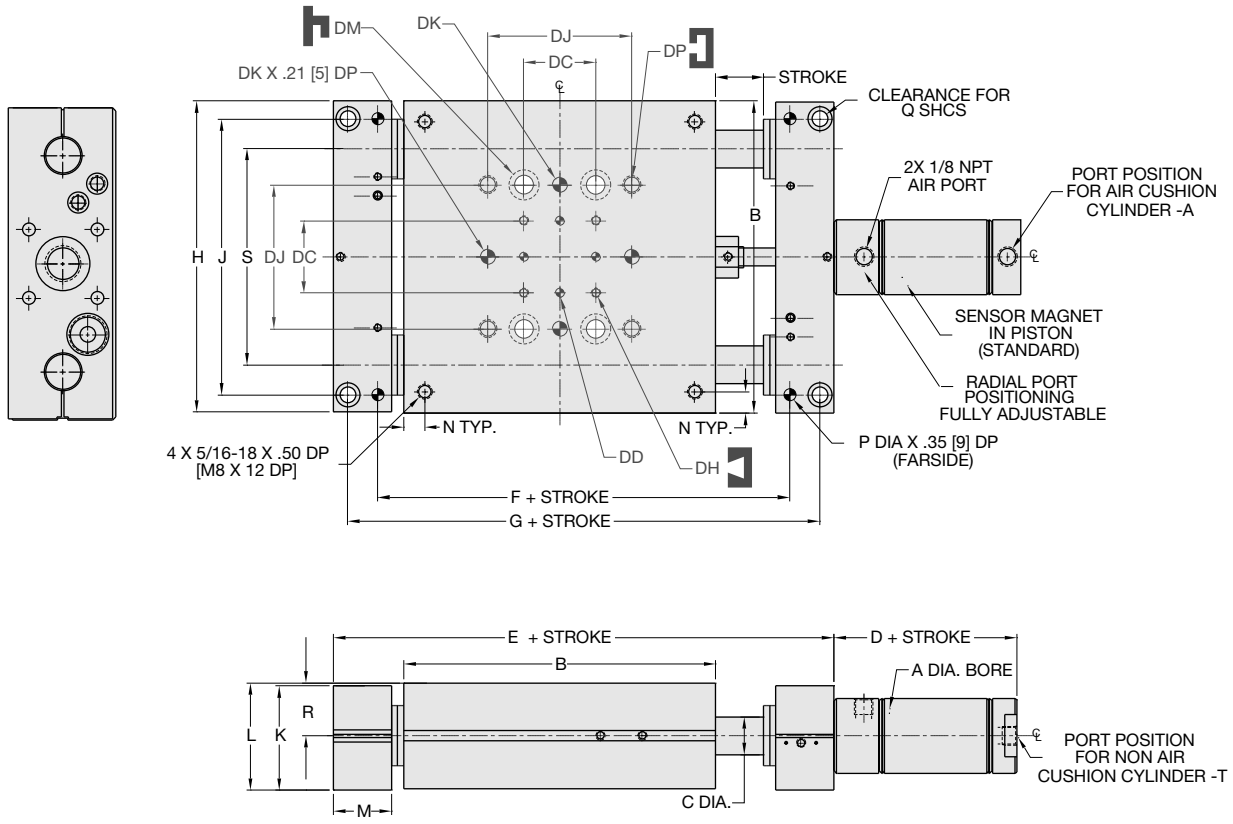

UNLESS OTHERWISE NOTED ALL TOLERANCES ARE AS SHOWN BELOW

Dimensions are symmetrical about centerline	Third Angle Projection	All Dowel Holes are SF (Slip Fit). Locational Tolerance ±.0005" or (±.013mm)	Metric Threads Course Pitch	Imperial in. 0.00 = ±.01 0.000 = ±.005 0.0000 = ±.0005	Metric [mm] [0.] = [±.25] [0.0] = [±.13] [0.00] = [±.013]
---	------------------------	--	-----------------------------	--	---

DIRECTCONNECT DIMENSIONS

STANDARD MOUNTING PATTERN FOR ALL SIZES

	Imperial (inches)
DC	1.500
DD	.1880 x .25 DP
DH	#10-32 x .38 DP
DJ	3.000
DK	.3130 x .37 DP
DM	Clearance for 3/8
DP	3/8-16 x .50 DP

MODEL #	BORE DIA.		BODY SIZE		SHAFT DIA.												
	A	B	C	D	E	F	G	H	J	K	L	M	N	P	Q	R	S
DLB-20	1 1/2	6.50	.787	3.0	9.42	7.5850	8.836	6.480	5.7500	2.180	2.236	1.210	.438	.2505	5/16	1.100	4.500
DLB-25	1 1/2	7.50	.984	3.0	10.84	8.7320	10.108	7.480	6.7500	2.180	2.236	1.420	.438	.3130	3/8	1.100	5.250

How to Order: Basic Unit

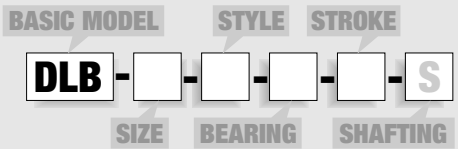

- SIZE 20, 25**
- STYLE T** Replaceable cylinder w/o adjustable air cushions
A Replaceable cylinder with adjustable air cushions
- BEARING B** Linear ball bearings
C Composite bushings
- STROKE** (inches)
DLB-20 **1-24** @ 1" increments
DLB-25 **1-26** @ 1" increments
- SHAFTING S** Corrosion resistant shafting
- Custom strokes available. Please consult factory.

SAMPLE ORDER: DLB-20-A-B-8

Ex: Base Slide, Size 20, Replaceable Cylinder w/Adjustable Air Cushions, Linear Ball Bushings, 8 inch Stroke

Accessories: (Order Separately)

	DLB-20	DLB-25	QTY/SLIDE
SHOCK/STOP ACCESSORIES			
Shock Absorber (adjustable dampening)	SHOK-029	SHOK-029	1 or 2
Adjustable Hard Stop	DLT-1023	DLT-1023	1 or 2
INDUCTIVE SENSOR ACCESSORIES †			
Inductive Sensor PNP Qk. Disconnect	OISP-011	OISP-011	1 or 2
Inductive Sensor NPN Qk. Disconnect	OISN-011	OISN-011	1 or 2
Quick. Disconnect 2M Cable Length	CABL-010	CABL-010	1 or 2
Quick. Disconnect 5M Cable Length	CABL-013	CABL-013	1 or 2
MAGNETIC SENSOR ACCESSORIES †**			
Magneto Resistive Sensor PNP Qk. Disc.	OHSP-005	OHSP-005	1 or 2
Magneto Resistive Sensor NPN Qk. Disc.	OHSN-005	OHSN-005	1 or 2
Quick. Disconnect 2M Cable Length	CABL-010	CABL-010	1 or 2
Quick. Disconnect 5M Cable Length	CABL-013	CABL-013	1 or 2
PNEUMATIC ACCESSORIES			
1/8 NPT Telescopic Airlines (up to 6")	OTAL-039	OTAL-039	1, 2, 3 or 4
1/8 NPT Telescopic Airlines (up to 12")	OTAL-040	OTAL-040	1, 2, 3 or 4
1/8 NPT Telescopic Airlines (up to 18")	OTAL-041	OTAL-041	1, 2, 3 or 4
1/8 NPT Telescopic Airlines (up to 24")	OTAL-042	OTAL-042	1, 2, 3 or 4
1/8 NPT Adjustable Flow Control	VLVF-004	VLVF-004	1 or 2

†Sensor and cable sold separately **Piston magnet standard

DLB SERIES
4.24

DIRECTCONNECT™



BASE SLIDE DLB -20, 25 -T, A REPLACEABLE CYLINDER WITH OR W/O ADJUST. AIR CUSHIONS

DIRECTCONNECT

DLB SERIES
4.25

DIRECTCONNECT™

DLB-20-T,A,U

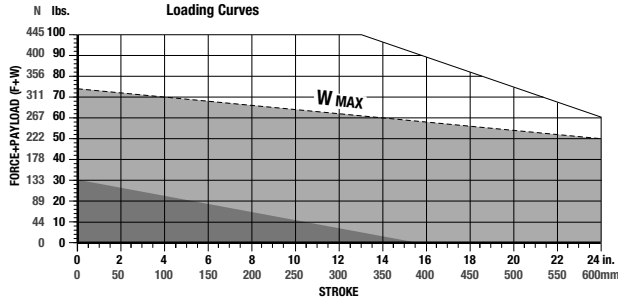

F=Externally applied force (lbs. or N)
W=Weight of payload (lbs. or N)
F+W=Total force (lbs. or N)

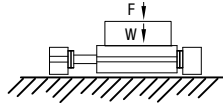

DLB-25-T,A,U

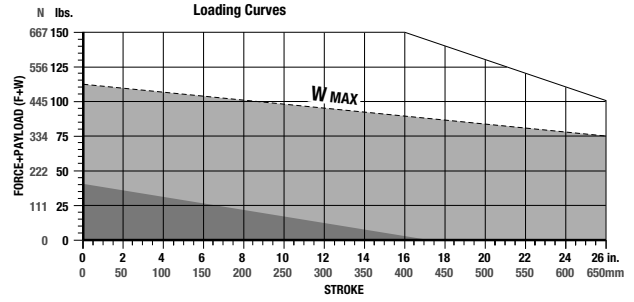

Shock Absorbers and Flow Controls are recommended for nearly all applications

(W) in this range use **Single Shock** in both directions

(W) in this range use **Bumpers or Cushioned Cylinder**

Shaded shock absorption ranges of horizontal payload (W) @ 80psi, flow controls fully open. For vertical applications do not exceed 1/2 of the recommended payload due to the additional acceleration effect of gravity.

Specifications

	DLB-20
Maximum Air Pressure	100 psi
Thrust Force @ 80psi/5.5bar	130 lbs.
Weight (Basic Unit -T, -A)	12.6 lbs.
Additional Weight per Stroke	0.38 lbs./in.
Cylinder Bore Diameter	1-1/2"
Shaft Diameter	0.787"
Maximum Moment Load	600 in.-lbs.

Specifications

	DLB-25
Maximum Air Pressure	100 psi
Thrust Force @ 80psi/5.5bar	130 lbs.
Weight (Basic Unit -T, -A)	17.7 lbs.
Additional Weight per Stroke	0.53 lbs./in.
Cylinder Bore Diameter	1-1/2"
Shaft Diameter	0.984"
Maximum Moment Load	1200 in.-lbs.

Accessory Mounting Technical Data

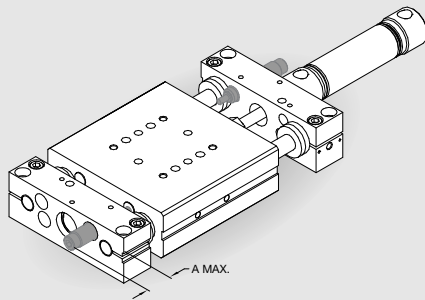

Shock Absorbers

- Full stroking piston rod
- Built-in hard stop
- Position adjustable
- Adjustable dampening

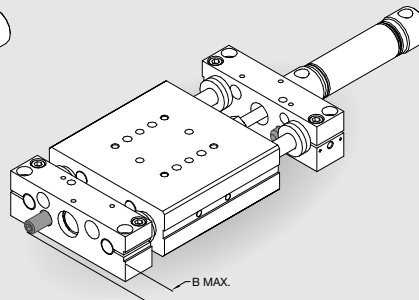

Adjustable Hard Stops

- For precision (+/- .001") hard stop end point positioning
- Allows for stop adjustment independent of shock absorber hard stop
- Allen wrench adjustable

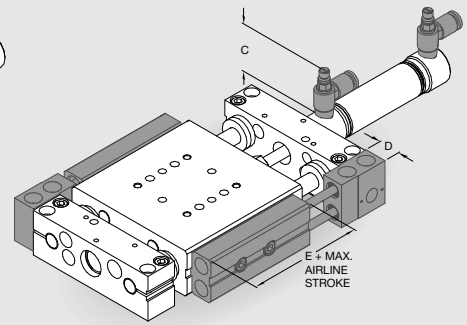

Telescoping Airlines

- Eliminate flexing air lines
- Self aligning air tube design extends useful seal life
- Modular stackable design. Up to (4) modules can be stacked
- Modules can be mounted on either side of slide
- 1/8 NPT pipe threads
- (2) user air ports per module

Flow Controls for Cylinders

- Thumb screw adjust with locking nut for adjusting cylinder speed
- 1/8 NPT pipe threads

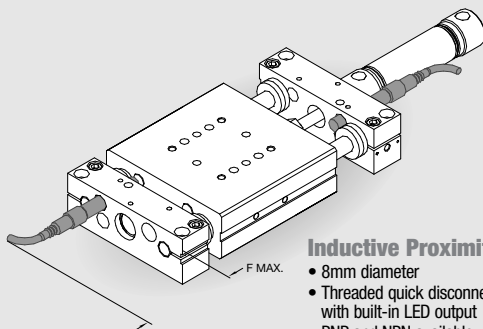

Inductive Proximity Sensors

- 8mm diameter
- Threaded quick disconnect with built-in LED output
- PNP and NPN available

Quick Disconnect Cable

- Threaded coupling with knurled head for secure electrical connections
- 2 meter cable length
- 5 meter cable length

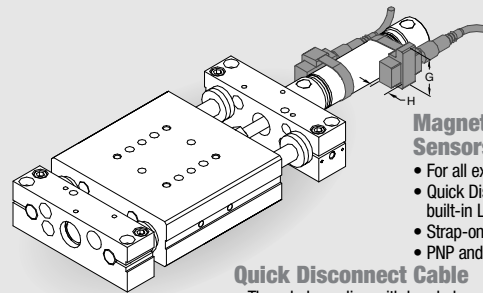

Magneto Resistive Sensors

- For all externally mounted cylinders
- Quick Disconnect with built-in LED output
- Strap-on mounting kit included
- PNP and NPN available

Quick Disconnect Cable

- Threaded coupling with knurled head for secure electrical connections
- 2 meter cable length
- 5 meter cable length

	A	B	C	D	E	F	G	H
DLB-20	2.03"	.10	1.25	.577	3.60	2.12	1.00	.43
DLB-25	1.82"	.10	1.25	.577	3.60	1.90	1.00	.43

Please see back cover for DE-STA-CO Global Locations. www.destaco.com

www.comoso.com



BASE SLIDE DLB -10M, 12M, 16M -N, U REPAIRABLE (NFPA STYLE) CYLINDER W/FIXED AIR CUSHIONS

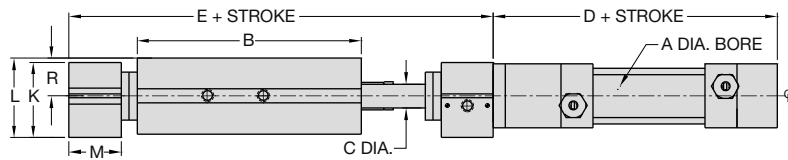
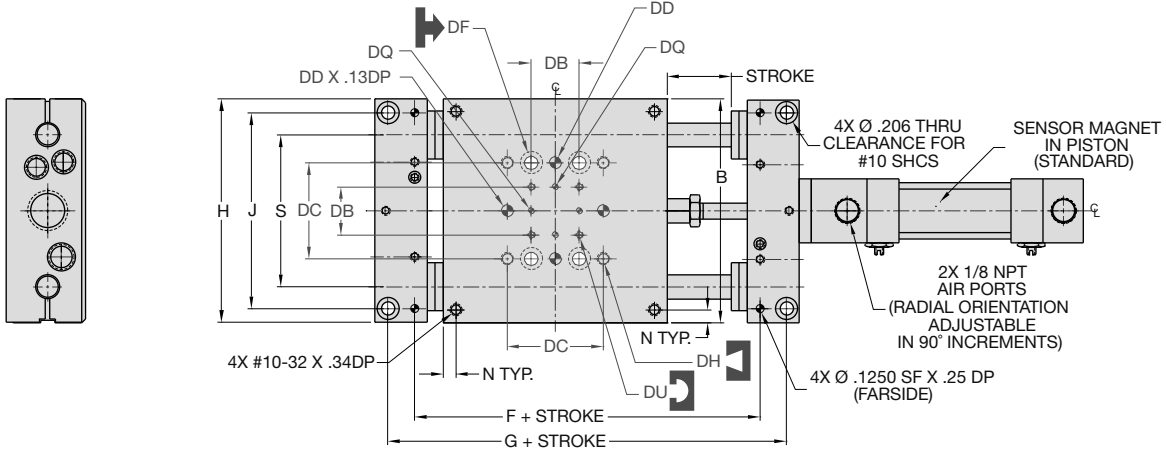

UNLESS OTHERWISE NOTED ALL TOLERANCES ARE AS SHOWN BELOW

				Imperial in.	Metric [mm]
Dimensions are symmetrical about centerline	Third Angle Projection	All Dowel Holes are SF (Slip Fit). Locational Tolerance ±.0005" or [±.013mm]	Metric Threads Course Pitch	0.00 ± .01 0.000 ± .005 0.0000 ± .0005	[.0] = [±.25] [0.0] = [±.13] [0.00] = [±.013]

DIRECTCONNECT DIMENSIONS

STANDARD MOUNTING PATTERN FOR ALL SIZES

	Imperial (inches)
DB	.750
DC	1.500
DD	.1880 x .25 DP
DF	Clearance for #10
DH	#10-32 x .34 DP
DQ	.0940 x .078 DP
DU	#4-40 X .25 DP

MODEL #	BORE DIA.		BODY SIZE		SHAFT DIA.		BASIC UNIT DIMENSIONS									
	A	B	C	D	E	F	G	H	J	K	L	M	N	R	S	
DLB-10	3/4	3.50	.375	3.44	5.63	4.3975	5.228	3.485	3.0600	1.178	1.245	.813	N/A	.594	2.375	
DLB-12	1 1/8	4.00	.472	3.44	6.13	4.8975	5.728	3.985	3.5000	1.615	1.657	.813	.375	.813	2.750	
DLB-16	1 1/8	4.75	.630	3.44	6.88	5.6475	6.478	4.735	4.2500	1.615	1.657	.813	.375	.813	3.250	

How to Order: Basic Unit

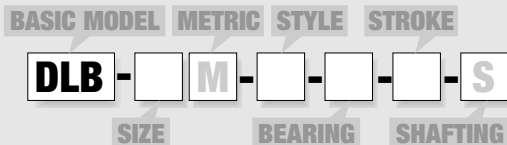

SIZE **10, 12, 16**

STYLE **N** Repairable NFPA cylinder w/ fixed air cushions (Not available in Metric)

U Non-powered unit (Without cylinder. Metric Units: Mount VDMA cylinder directly. NFPA not available. Imperial Units: Mount NFPA cylinders using NFPA mounting kit. VDMA not available.)

BEARING **B** Linear ball bearings
C Composite bushings

STROKE (inches)
DLB-10 **1-12** @ 1" increments
DLB-12 **1-16** @ 1" increments
DLB-16 **1-20** @ 1" increments

Custom strokes available. Please consult factory.

STROKE (mm)
DLB-10M **25, 50, 80, 100, 125, 160, 200, 250, 300**
DLB-12M **25, 50, 80, 100, 125, 160, 200, 250, 300, 320, 360, 400**
DLB-16M **25, 50, 80, 100, 125, 160, 200, 250, 300, 320, 360, 400, 500**

SHAFTING **S** Corrosion resistant shafting

SAMPLE ORDER: DLB-10-N-B-6

Ex: Base Slide, Size 10, Repairable Cylinder w/ Fixed Air Cushions, Linear Ball Bushings, 6 Inch Stroke

Accessories: (Order Separately)

SHOCK/STOP ACCESSORIES

	DLB-10	DLB-12	DLB-16	QTY/SLIDE
Shock Absorber	SHOK-028	SHOK-010	SHOK-010	1 or 2
Adjustable Hard Stop	DLT-1023	DLT-1023	DLT-1023	1 or 2

INDUCTIVE SENSOR ACCESSORIES*

	DLB-10	DLB-12	DLB-16	QTY/SLIDE
Inductive Sensor PNP Qk. Disconnect	OISP-011	OISP-011	OISP-011	1 or 2
Inductive Sensor NPN Qk. Disconnect	OISN-011	OISN-011	OISN-011	1 or 2
Quick. Disconnect 2M Cable Length	CABL-010	CABL-010	CABL-010	1 or 2
Quick. Disconnect 5M Cable Length	CABL-013	CABL-013	CABL-013	1 or 2

MAGNETIC SENSOR ACCESSORIES**

	DLB-10	DLB-12	DLB-16	QTY/SLIDE
Magneto Resistive Sensor PNP Qk. Disc.	OHSP-005	OHSP-005	OHSP-005	1 or 2
Magneto Resistive Sensor NPN Qk. Disc.	OHSN-005	OHSN-005	OHSN-005	1 or 2
Quick. Disconnect 2M Cable Length	CABL-010	CABL-010	CABL-010	1 or 2
Quick. Disconnect 5M Cable Length	CABL-013	CABL-013	CABL-013	1 or 2

PNEUMATIC ACCESSORIES

	DLB-10	DLB-12	DLB-16	QTY/SLIDE
NFPA Cylinder Mounting Kit (-U only)	ODLT-001	ODLT-002	ODLT-002	1
1/8 NPT Telescopic Airlines (up to 6")	OTAL-039	OTAL-039	OTAL-039	1,2,3 or 4
1/8 NPT Telescopic Airlines (up to 12")	OTAL-040	OTAL-040	OTAL-040	1,2,3 or 4
1/8 NPT Telescopic Airlines (up to 18")	OTAL-041	OTAL-041	OTAL-041	1,2,3 or 4
1/8 NPT Telescopic Airlines (up to 24")	OTAL-042	OTAL-042	OTAL-042	1,2,3 or 4
1/8 NPT Adjustable Flow Control	VLVF-004	VLVF-004	VLVF-004	1 or 2

*Sensor and cable sold separately **Piston magnet standard



BASE SLIDE DLB -10M, 12M, 16M -N, UNREPAIRABLE (NFPA STYLE) CYLINDER W/ADJ. AIR CUSHIONS



DLB-10-N,U

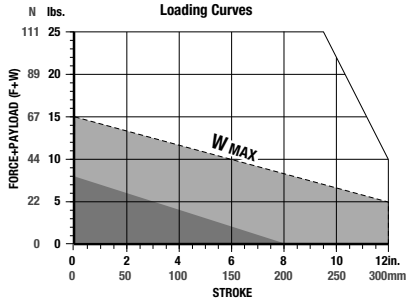

DLB-12-N,U

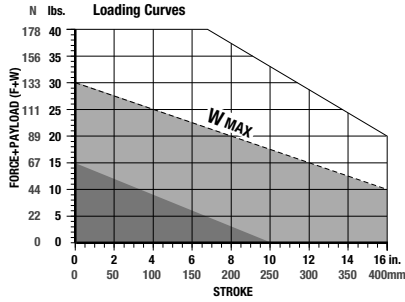

DLB-16-N,U

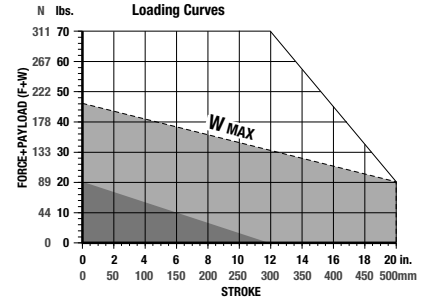

F=Externally applied force (lbs. or N)
W=Weight of payload (lbs. or N)
F+W=Total force (lbs. or N)

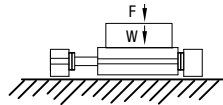

Shock Absorbers and Flow Controls are recommended for nearly all applications

(W) in this range use **Single Shock** in both directions

(W) in this range use **Bumpers or Cushioned Cylinder**

Shaded shock absorption ranges of horizontal payload (W) @ 80psi, flow controls fully open. For vertical applications do not exceed 1/2 of the recommended payload due to the additional acceleration effect of gravity.

Specifications

	DLB-10
Maximum Air Pressure.....	100 psi
Thrust Force @ 80psi/5.5bar.....	29 lbs.
Weight (Basic Unit -N).....	2.01 lbs.
Additional Weight per Stroke.....	0.08 lbs./in.
Cylinder Bore Diameter.....	3/4"
Shaft Diameter.....	0.375"
Maximum Moment Load.....	75 in.-lbs.

Specifications

	DLB-12
Maximum Air Pressure.....	100 psi
Thrust Force @ 80psi/5.5bar.....	71 lbs.
Weight (Basic Unit -N).....	3.79 lbs.
Additional Weight per Stroke.....	0.16 lbs./in.
Cylinder Bore Diameter.....	1-1/8"
Shaft Diameter.....	0.472"
Maximum Moment Load.....	150 in.-lbs.

Specifications

	DLB-16
Maximum Air Pressure.....	100 psi
Thrust Force @ 80psi/5.5bar.....	71 lbs.
Weight (Basic Unit -N).....	5.09 lbs.
Additional Weight per Stroke.....	0.24 lbs./in.
Cylinder Bore Diameter.....	1-1/8"
Shaft Diameter.....	0.630"
Maximum Moment Load.....	300 in.-lbs.

Accessory Mounting Technical Data

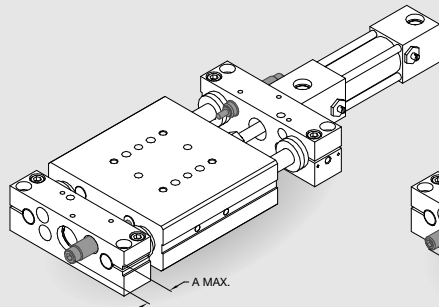

Shock Absorbers

- Full stroking piston rod
- Built-in hard stop
- Allen wrench adjustable

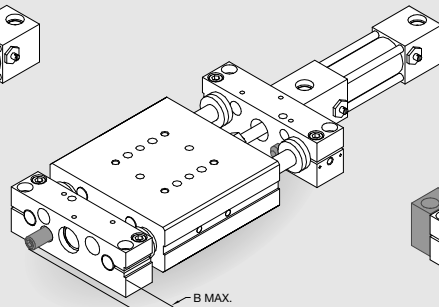

Adjustable Hard Stops

- For precision (+/- .001") hard stop end point positioning
- Allows for stop adjustment independent of shock absorber hard stop
- Allen wrench adjustable

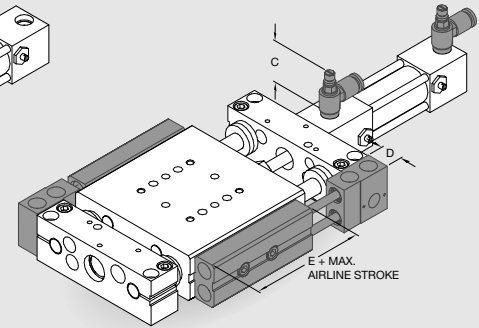

Flow Controls for Cylinders

- Thumb screw adjust with locking nut for adjusting cylinder speed
- 1/8 NPT pipe threads

Telescoping Airlines

- Eliminate flexing air lines
- Self aligning air tube design extends useful seal life
- Modular stackable design. Up to (4) modules can be stacked
- Modules can be mounted on either side of slide
- 1/8 NPT pipe threads
- (2) user air ports per module

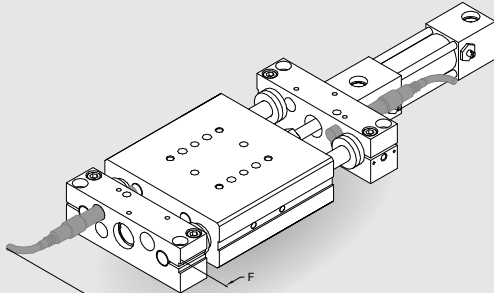

Inductive Proximity Sensors

- 8mm diameter
- Threaded quick disconnect with built-in LED output
- PNP and NPN available

Quick Disconnect Cable

- Threaded coupling with knurled head for secure electrical connections
- 2 meter cable length
- 5 meter cable length

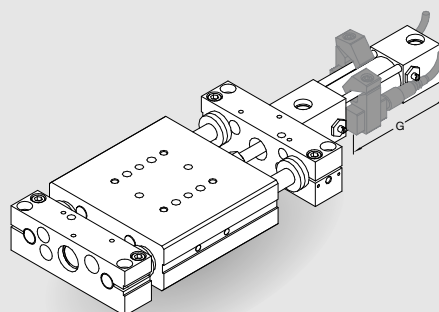

Magneto Resistive Sensors

- For all externally mounted cylinders
- Quick Disconnect with built in LED output
- Clamp-on mounting kit included
- PNP and NPN available

Quick Disconnect Cable

- Threaded coupling with knurled head for secure electrical connections
- 2 meter cable length
- 5 meter cable length

NFPA Cylinder Mounting Kit

- Used to mount standard face mounted NFPA cylinders to non-powered units (-U)

	A	B	C	D	E	F	G
DLB-10	.70"	.47	1.25	.577	3.60	2.5	3.00
DLB-12	.95"	.47	1.25	.577	3.60	2.5	3.00
DLB-16	.95"	.47	1.25	.577	3.60	2.5	3.00
DLB-10M	17.8mm	11.9	31.8	14.7	91.4	63.5	76.2
DLB-12M	24.1mm	11.9	31.8	14.7	91.4	63.5	76.2
DLB-16M	24.1mm	11.9	31.8	14.7	91.4	63.5	76.2

DLB SERIES

4.27

DIRECTCONNECT™



BASE SLIDE DLB -20M, 25M -N, R, U REPAIRABLE (NFPA/VDMA) CYLINDER W/ ADJ. AIR CUSHIONS

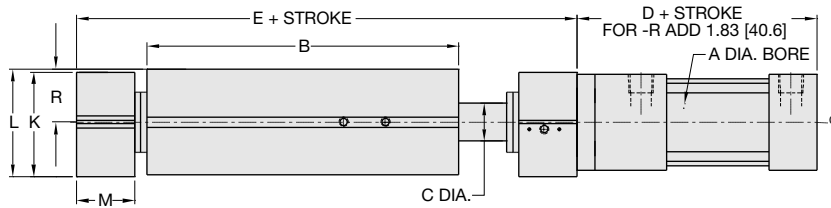
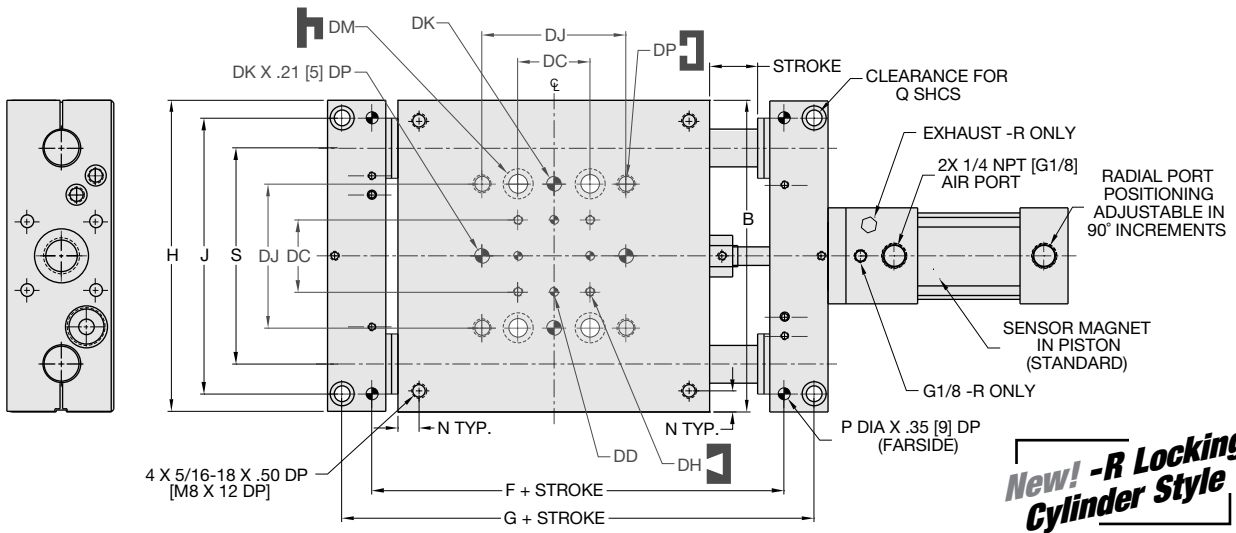

UNLESS OTHERWISE NOTED ALL TOLERANCES ARE AS SHOWN BELOW

Dimensions are symmetrical about centerline	Third Angle Projection	All Dowel Holes are SF (Slip Fit). Locational Tolerance ±.0005" or [±.013mm]	Metric Threads Course Pitch	Imperial in. 0.00 = ±.01 0.000 = ±.005 0.0000 = ±.0005	Metric [mm] [0.] = [±.25] [0.0] = [±.13] [0.00] = [±.013]
---	------------------------	--	-----------------------------	--	---

DIRECTCONNECT DIMENSIONS STANDARD MOUNTING PATTERN FOR ALL SIZES

Imperial (inches)	Metric (mm)
DC 1.500	38.1
DD .1880 x .25 DP	5mm H7 x 6 DP
DH #10-32 x .38 DP	M5 x 9 DP
DJ 3.000	76.2
DK .3130 x .37 DP	8mm H7 x 9.4 DP
DM Clearance for 3/8"	Clearance for M10
DP 3/8-16 X .50 DP	M10 X 12 DP

MODEL #	BORE DIA. -N		BORE DIA. -R		BODY SIZE		SHAFT DIA.		BASIC UNIT DIMENSIONS												
	A	B	C	D	E	F	G	H	J	K	L	M	N	P	Q	R	S				
DLB-20	1 1/2	32mm	6.50	.787	3.63	9.42	7.5850	8.836	6.480	5.7500	2.180	2.236	1.210	.438	.2505	5/16	1.100	4.500			
DLB-25	1 1/2	32mm	7.50	.984	3.63	10.84	8.7320	10.108	7.480	6.7500	2.180	2.236	1.420	.438	.3130	3/8	1.100	5.250			
DLB-20M	32	32	165.1	20	98.0	239.3	192.66	224.4	164.6	146.05	55.4	56.8	30.7	11.1	6.00	M8	27.94	114.30			
DLB-25M	32	32	190.5	25	98.0	275.3	221.79	256.7	190.0	171.45	55.4	56.8	36.1	11.1	8.00	M10	27.94	113.35			

How to Order: Basic Unit

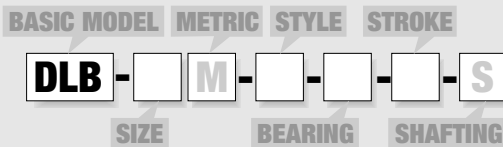

- SIZE** 20, 25
- METRIC** M
- STYLE** N Repairable NFPA/VDMA cylinder w/adjustable air cushions
R Repairable locking VDMA cylinder w/adjustable air cushions
U Non-powered unit (Without cylinder. Metric Units: Mount VDMA cylinder directly. NFPA not available. Imperial Units: Mount NFPA cylinders using NFPA mounting kit. VDMA not available.)
- BEARING** B Linear ball bearings
C Composite bushings
- STROKE** (inches)
DLB-20 1-24 @ 1" increments
DLB-25 1-26 @ 1" increments
- STROKE** (mm)
DLB-20M 25, 50, 80, 100, 125, 160, 200, 250, 300, 320, 360, 400, 500
DLB-25M 25, 50, 80, 100, 125, 160, 200, 250, 300, 320, 360, 400, 500
- SHAFTING** S Corrosion resistant shafting

SAMPLE ORDER: DLB-20-N-B-12

Ex: Base Slide, Size 20, Repairable NFPA Cylinder w/Adjustable Air Cushions, Linear Ball Bushings, Inch Stroke

Accessories: (Order Separately)

SHOCK/STOP ACCESSORIES

	DLB-20M	DLB-25M	QTY/SLIDE
Shock Absorber (adjustable dampening)	SHOK-029	SHOK-029	1 or 2
Adjustable Hard Stop	DLT-1023	DLT-1023	1 or 2

INDUCTIVE SENSOR ACCESSORIES†

	DLB-20M	DLB-25M	QTY/SLIDE
Inductive Sensor PNP Qk. Disconnect	OISP-011	OISP-011	1 or 2
Inductive Sensor NPN Qk. Disconnect	OISN-011	OISN-011	1 or 2
Quick. Disconnect 2M Cable Length	CABL-010	CABL-010	1 or 2
Quick. Disconnect 5M Cable Length	CABL-013	CABL-013	1 or 2
Cable Extension Cord 1M Length	CABL-015	CABL-015	1 or 2
Cable Extension Cord 2M Length	CABL-016	CABL-016	1 or 2

MAGNETIC SENSOR ACCESSORIES† **

	DLB-20M	DLB-25M	QTY/SLIDE
Magneto Resistive Sensor PNP Qk. Disc.	OHSP-020	OHSP-020	1 or 2
Magneto Resistive Sensor NPN Qk. Disc.	OHSN-020	OHSN-020	1 or 2
Quick. Disconnect 2M Cable Length	CABL-010	CABL-010	1 or 2
Quick. Disconnect 5M Cable Length	CABL-013	CABL-013	1 or 2
Cable Extension Cord 1M Length	CABL-015	CABL-015	1 or 2
Cable Extension Cord 2M Length	CABL-016	CABL-016	1 or 2

PNEUMATIC ACCESSORIES

	DLB-20M	DLB-25M	QTY/SLIDE
NFPA Cylinder Mounting Kit (-U only)	ODLB-001	ODLB-001	1
1/8 NPT Telescopic Airlines (up to 6")	OTAL-039	OTAL-039	1, 2, 3 or 4
1/8 NPT Telescopic Airlines (up to 12")	OTAL-040	OTAL-040	1, 2, 3 or 4
1/8 NPT Telescopic Airlines (up to 18")	OTAL-041	OTAL-041	1, 2, 3 or 4
1/8 NPT Telescopic Airlines (up to 24")	OTAL-042	OTAL-042	1, 2, 3 or 4
1/4 NPT Adjustable Flow Control	VLVF-006	VLVF-006	1 or 2
G1/8 Telescopic Airlines (up to 160mm)	OTAL-045	OTAL-045	1, 2, 3 or 4
G1/8 Telescopic Airlines (up to 300mm)	OTAL-046	OTAL-046	1, 2, 3 or 4
G1/8 Telescopic Airlines (up to 450mm)	OTAL-047	OTAL-047	1, 2, 3 or 4
G1/8 Telescopic Airlines (up to 600mm)	OTAL-048	OTAL-048	1, 2, 3 or 4
G1/8 Adjustable Flow Control	VLVF-005	VLVF-005	1 or 2
G1/8 Male to 1/8 NPT Adapter	PLFT-025	PLFT-025	1 or 2

†Sensor and cable sold separately **Piston magnet standard

Please see back cover for DE-STA-CO Global Locations. www.destaco.com

www.comoso.com

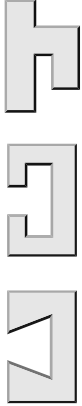

DLB SERIES

4.28





BASE SLIDE DLB -20M, 25M -N, R, U REPAIRABLE (NFPA/VDMA) CYLINDER W/ ADJ. AIR CUSHIONS



DLB -20M -N, R, U

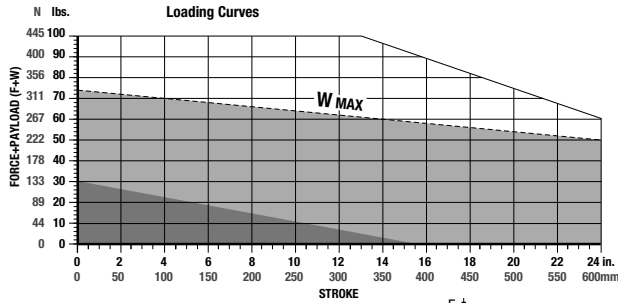

F=Externally applied force (lbs. or N)
W=Weight of payload (lbs. or N)
F+W=Total force (lbs. or N)

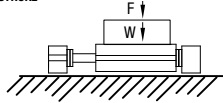

DLB -25M -N, R, U

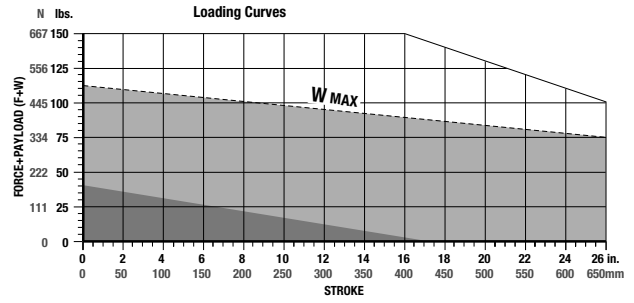

Shock Absorbers and Flow Controls are recommended for nearly all applications

(W) in this range use **Single Shock** in both directions

(W) in this range use **Bumpers or Cushioned Cylinder**

Shaded shock absorption ranges of horizontal payload (W) @ 80psi, flow controls fully open. For vertical applications do not exceed 1/2 of the recommended payload due to the additional acceleration effect of gravity.

Specifications	DLB-20	DLB-20M
Maximum Air Pressure.....	100 psi	6.9 bar
Thrust Force @ 80psi/5.5bar.....	117 lbs.	443 N
Weight (Basic Unit -N, -R).....	12.9 lbs.	5.9 kg
Additional Weight per Stroke -N, -R	0.53 lbs./in.	9.5 g/mm
Cylinder Bore Diameter -N	1-1/2"	32 mm
Cylinder Bore Diameter -R	32 mm	32 mm
Shaft Diameter.....	0.787"	20 mm
Maximum Moment Load.....	600 in.-lbs.	67.8 N-m
Min. Air Pressure to Release Cylinder Lock -R	60 psi	4 bar
Holding Force of Locking Mechanism -R	123 psi	550 N

Specifications	DLB-25	DLB-25M
Maximum Air Pressure.....	100 psi	6.9 bar
Thrust Force @ 80psi/5.5bar.....	117 lbs.	443 N
Weight (Basic Unit -N, -R).....	18.0 lbs.	8.3 kg
Additional Weight per Stroke -N, -R	0.68 lbs./in.	12.1 g/mm
Cylinder Bore Diameter -N	1-1/2"	32 mm
Cylinder Bore Diameter -R	32 mm	32 mm
Shaft Diameter.....	0.984"	25 mm
Maximum Moment Load.....	1200 in.-lbs.	135 N-m
Min. Air Pressure to Release Cylinder Lock -R	60 psi	4 bar
Holding Force of Locking Mechanism -R	123 psi	550 N

Accessory Mounting Technical Data

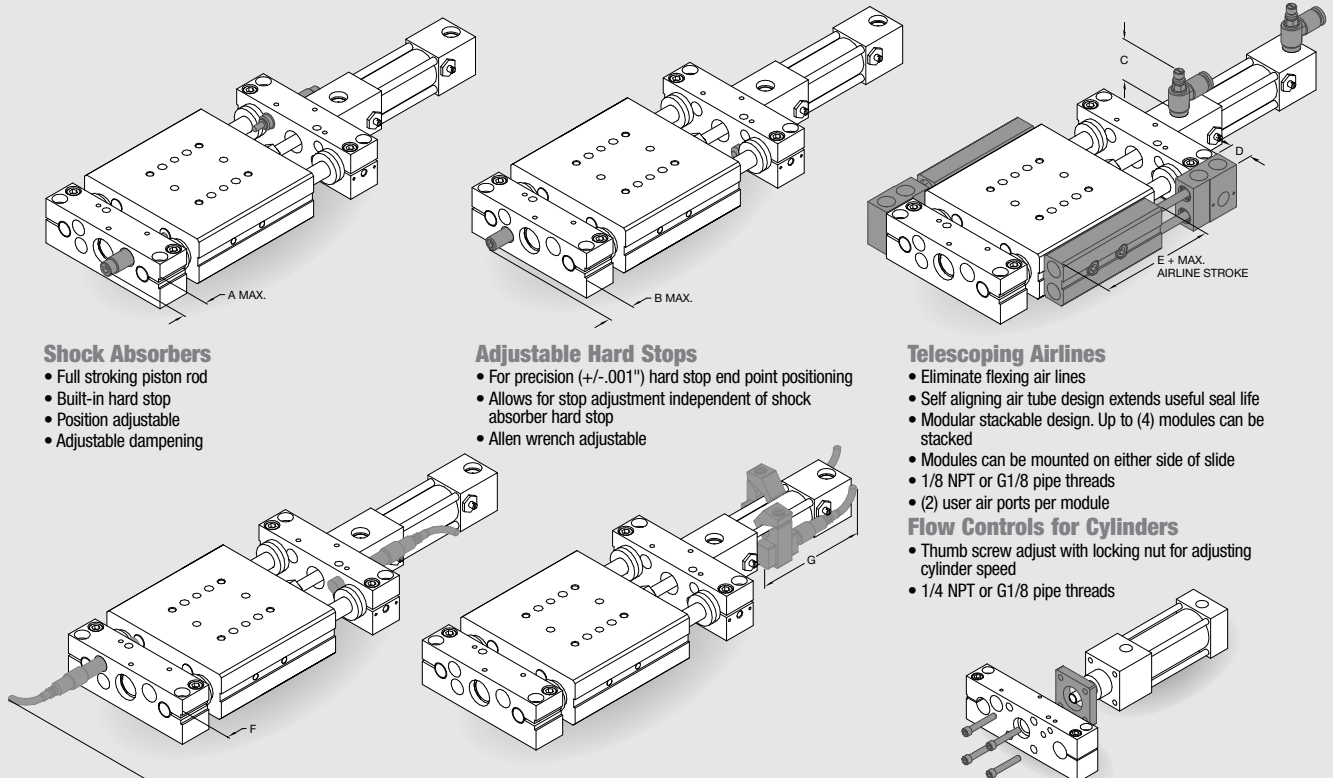

Shock Absorbers

- Full stroking piston rod
- Built-in hard stop
- Position adjustable
- Adjustable dampening

Adjustable Hard Stops

- For precision (+/- .001") hard stop end point positioning
- Allows for stop adjustment independent of shock absorber hard stop
- Allen wrench adjustable

Telescoping Airlines

- Eliminate flexing air lines
- Self aligning air tube design extends useful seal life
- Modular stackable design. Up to (4) modules can be stacked
- Modules can be mounted on either side of slide
- 1/8 NPT or G1/8 pipe threads
- (2) user air ports per module

Flow Controls for Cylinders

- Thumb screw adjust with locking nut for adjusting cylinder speed
- 1/4 NPT or G1/8 pipe threads

Inductive Proximity Sensors

- 8mm diameter
- Threaded quick disconnect with built-in LED output
- PNP and NPN available

Quick Disconnect Cable

- Threaded coupling with knurled head for secure electrical connections
- 2 meter cable length
- 5 meter cable length
- Quick disconnect cable extensions cords available in 1 or 2 meter lengths

Magneto Resistive Sensors

- For all externally mounted cylinders
- Quick Disconnect with built in LED output
- Clamp-on mounting kit included
- PNP and NPN available

Quick Disconnect Cable

- Threaded coupling with knurled head for secure electrical connections
- 2 meter cable length
- 5 meter cable length
- Quick disconnect cable extensions cords available in 1 or 2 meter lengths

NFPA Cylinder Mounting Kit

- Used to mount standard face mounted NFPA cylinders to non-powered units (**-U**) Refer to accessories mounting section.

	A	B	C	D	E	F	G
DLB-20	2.03"	.10	1.40	.577	3.60	2.12	3.00
DLB-25	1.82"	.10	1.40	.577	3.60	1.90	3.00
DLB-20M	51.6mm	2.5	31.8	14.7	91.4	53.8	76.2
DLB-25M	46.2mm	2.5	31.8	14.7	91.4	48.3	76.2

DLB-T, A, N, R, U Series Exploded View

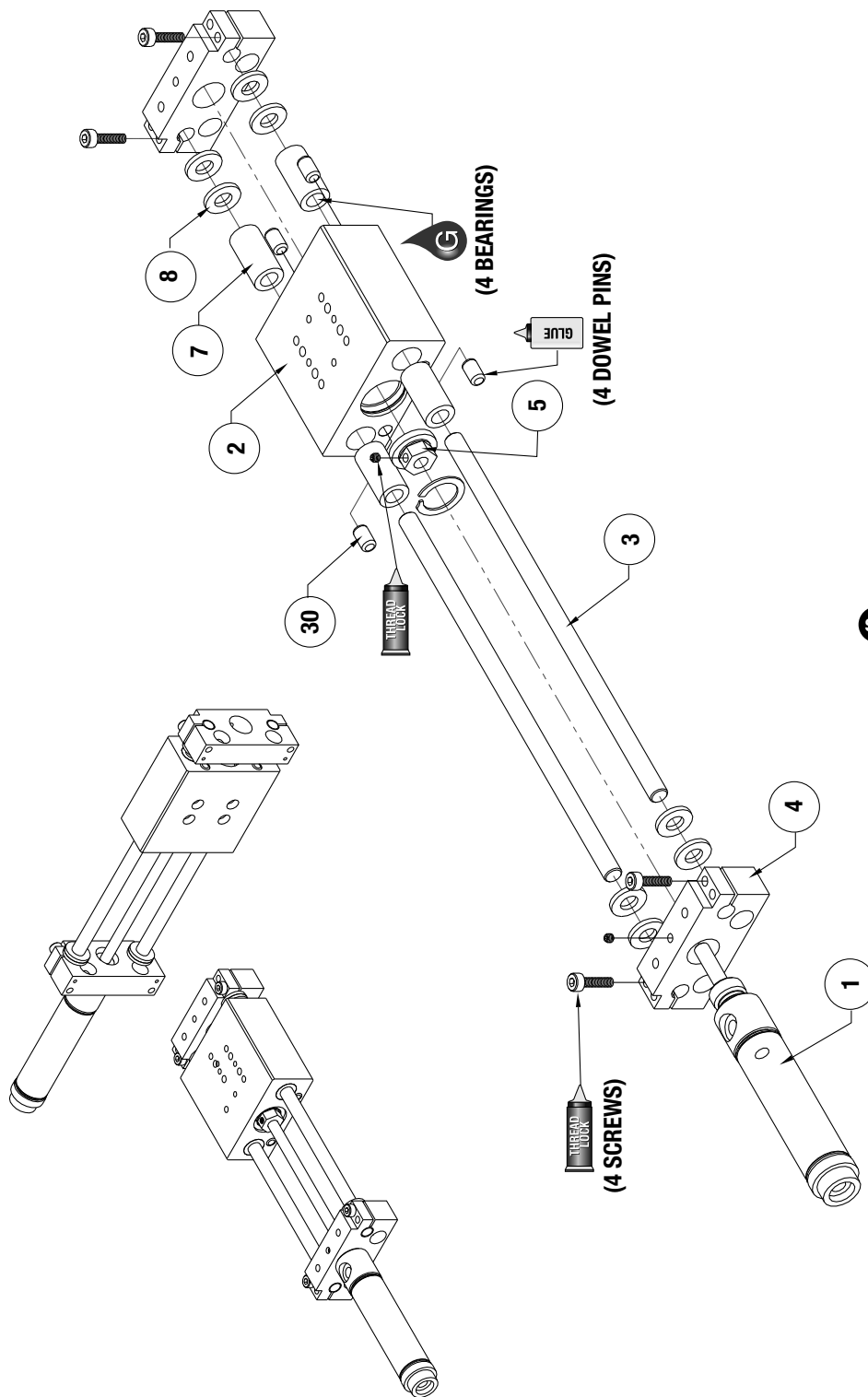

Item	Qty	Name
01	1	Cylinder
02	1	Body, Internally Powered
03	2	Guide Shaft
04	2	End Block
05	1	Coupling, Externally Powered
07	4	Bushing
08	8	Shock Pad, Urethane
30	4	Dowel Pin

NOTE: Contact the Robohand Sales Department for a complete spare parts list with order numbers and prices.

Assembly Procedure

- 1) Press bearings into body, insert shafts, and slide bumpers over each shaft end.
- 2) Install external coupler to body with retainer ring.
- 3) Mount end blocks onto shaft ends and tighten.
- 4) Attach cylinder through end block and external coupler.
- 5) Lock cylinder in place by tightening set screws in the external coupler and end block.

SK Seal Repair Kit Order #'s See Product Data Sheets

DLB-T, A, N, R, U
SERIES
MAINTENANCE
4.30



Seal Kit Items



Thread Locker



Krytox™ Lubricant



Lightweight Machine Oil



Teflon® Based Grease



Super Bonder



Third Angle Projection

Please see back cover for DE-STA-CO Global Locations. www.destaco.com

www.comoso.com

LOCKING CYLINDER -R PLUMBING DIAGRAM

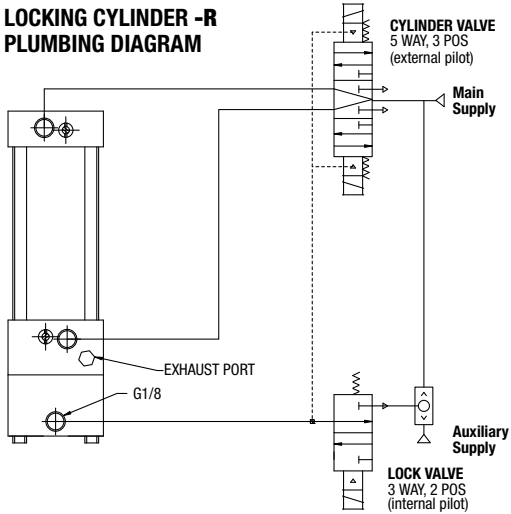

- 1) Lock valve must be maintained energized during cylinder motion, otherwise lock is engaged and cylinder valve shifts to mid position.
- 2) Cylinder valve must be maintained energized during extend or retract. Also, keep energized at end of stroke until change of direction is desired.
- 3) Mid-position of 5/3 cylinder valve may be pressurized outlets if the combination of pressure load on the cylinder and inertia effects of the attached load do not exceed the holding force rating of the locking device, including allowance for wear.
- 4) DO NOT use cylinder lines for any logic functions - pressure levels vary too much.

Item Qty Name

Item	Qty	Name
01	1	Cylinder
02	1	Body, Internally Powered
03	2	Guide Shaft
04	2	End Block
05	1	Coupling, Externally Powered
07	4	Bushing
08	8	Shock Pad, Urethane
30	4	Dowel Pin

NOTE: Contact the Robohand Sales Department for a complete spare parts list with order numbers and prices.

NOTE: For accessory mounting, see product data sheets.

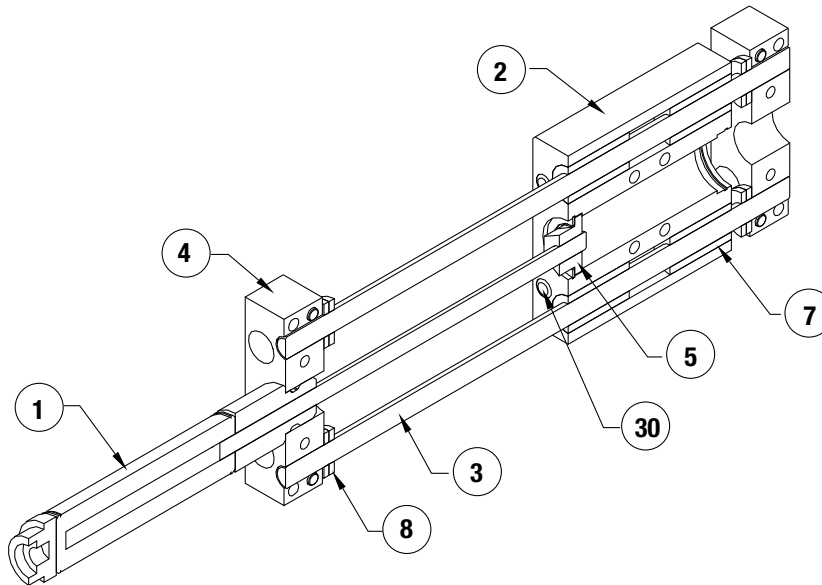

Seal Kit
Items



Thread
Locker



Krytox™
Lubricant



Lightweight
Machine Oil



Teflon® Based
Grease



Super
Bonder

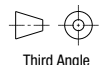

Third Angle
Projection