

MDE/HDE Series Index Drives

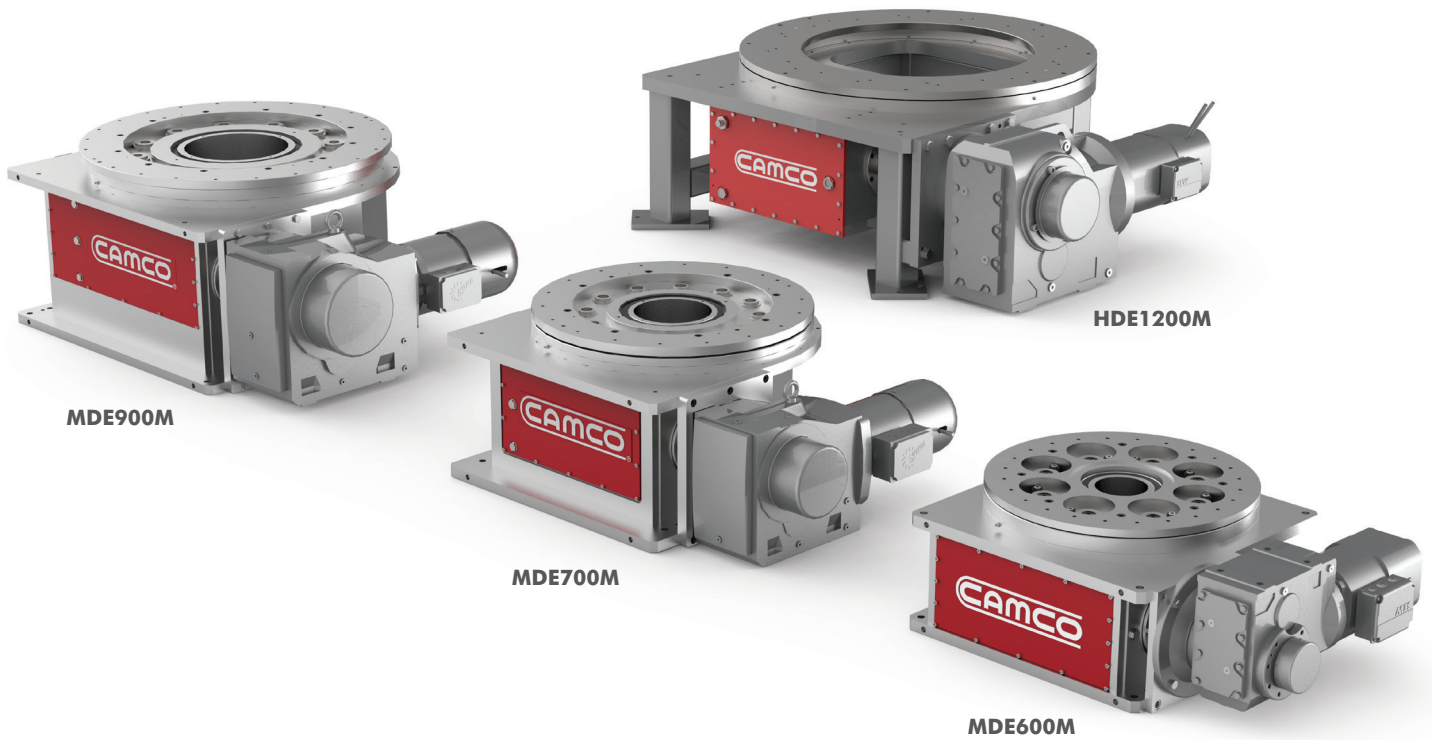

Features:

CAMCO® MDE and HDE series maintenance free mechanical and servo-based indexers. Built for cost sensitive applications

- **Flex-Mount housing** to meet your application’s height and width requirements
- **No oil changes or service required** for 5 years or 10,000 hours, whichever comes first
- **Quick access** field replaceable cam followers
- **Quick-stop** safe operation with industry leading E-stops times
- **Easy system integration** with SEW® and NORD® drive solutions
- **Zero backlash** for precision positioning

Table of Contents

MDE600M.....	3
MDE700M.....	7
MDE900M.....	11
HDE1200M	15
HDE1200S	19



MDE/HDE Series Index Drives How to Select a Reducer Ratio

Choosing the Right Indexer Option is Easy

MDE and HDE series Indexers make it easy to find the right reducer ratio and brake torque setting for your application requirements. The charts are designed to show the motion time between different stop configurations based on the indexer’s maximum axial load. The number in each cell is the maximum inertia allowed with each configuration. The charts are also color coded to indicate which brake torque setting works best for your choice of reducer ratios. Look at the following example to see how to properly use the charts.

Indexer	Axial Load	Torque Rating*
MDE600M	3200 kg	10000 Nm
MDE700M	5700 kg	8400 Nm
MDE900M	6800 kg	16500 Nm
HDE1200M	14500 kg	27500 Nm
HDE1200S	14500 kg	17500 Nm

*Ratings vary with indexer configuration

Using Catalog Indexer Reducer Ratio Charts:

Selecting the proper indexer requires the following application data:

- a) Axial Load
- b) Number of stops (stations)
- c) Application motion (index) time: required time to move between stations
- d) Total inertia of moving parts

ND1	Motion Time† [seconds]				
Gear Motor	1.36	1.50	1.69	2.06	2.35
Stops	Maximum Inertia* [Kgm ²]				
2	63	112	234	424	533
3	411	602	996	1643	2054
4	986	1397	2213	3574	4472
6	2400	3341	5170	8259	10344
8	4808	6594	10015	15874	19934
12	11729	14112	18098	21145	21145
16	14275	17764	21145	21145	21145
Reducer Ratio Options					
	A	B	C	D	E

Application Example

Payload: 7500 kg
 Stops: 4
 Move time 2.06 seconds
 Application inertia: 3190 Kgm²

Notes:

- 1) Axial load must be less than mass (axial load) used for chart.
- 2) Move time must be greater than chart value.
- 3) Inertia must be less than max inertia. Include work forces and overturning moments.

- Step 1:** Select Indexer with ratings that exceeds your payload weight
- Step 2:** Identify the indexer’s gear motor option from the ordering information and locate the corresponding reducer ratio chart.
- Step 3:** Identify the row that matches the desired number of application stops.
- Step 4:** Identify the motion time column that is equal to or less than the application motion (index) time.
- Step 5:** The intersected chart value indicates reducer ratio Option **D**.
- Step 6:** Verify your application inertia is less than the maximum inertia indicated in the chart where the row and column intersect.

MDE600M Series Indexer How To Order



Motion	Number of Stops	Gear Motor Ratios				Gear Motor Mount	(See Figure 1)	Dwell Sensor (See figure 2)	
		Reducer Ratio	ND1	ND2	SW1			SW2	
A	2	A	59.17	55.69	57.28	64.75	1	Side 1	0 No Sensor
B	3	B	64.08	63.25	60.66	73.99	2	Side 2	A Bracket for M12 Sensor only
C	4	C	75.91	68.61	68.95	78.07			B PNP N/O w/Bracket Qty:1
D	6	D	84.17	76.18	76.37	88.97			C PNP N/O w/Bracket Qty:2
E	8	E	93.50	86.43	90.04	97.05			D NPN N/O w/Bracket Qty:1
F	12	F	110.77	95.96					E NPN N/O w/Bracket Qty:2
		G	117.70	117.79					F PNP N/C w/Bracket Qty:1
		H	139.44	132.79					G PNP N/C w/Bracket Qty:2
									H NPN N/C w/Bracket Qty:1
									I NPN N/C w/Bracket Qty:2

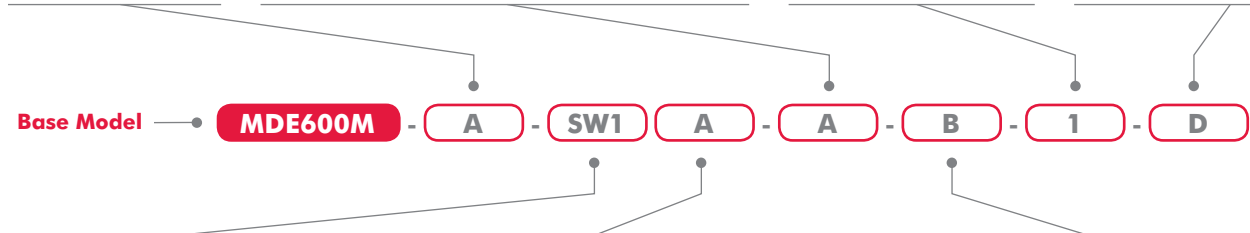

Gear Motor	Description	Motor Voltage	Description
ND1	NORD® 1.5 kW (2 hp)	A	400 VAC
ND2	NORD® 4.0 kW (5.4 hp)	B	460 VAC
SW1	SEW® 1.5 kW (2 hp)	C	575 VAC
SW2	SEW® 3 kW (4 hp)		

Brake	Gear Motor Brake Options*			
	ND1	ND2	SW1	SW2
A	AC 20 Nm	AC 28 Nm	AC 14 Nm	AC 28 Nm
B	AC 14 Nm	AC 20 Nm	AC 10 Nm	AC 20 Nm
C	DC 20 Nm	DC 28 Nm	DC 14 Nm	DC 28 Nm
D	DC 14 Nm	DC 20 Nm	DC 10 Nm	DC 20 Nm

*AC = Uses same AC voltage as Motor (except 575 VAC requires 110 VAC for brake voltage)
 DC = Uses 24 VDC signal logic

Figure 1: Gear Motor Mounting Position

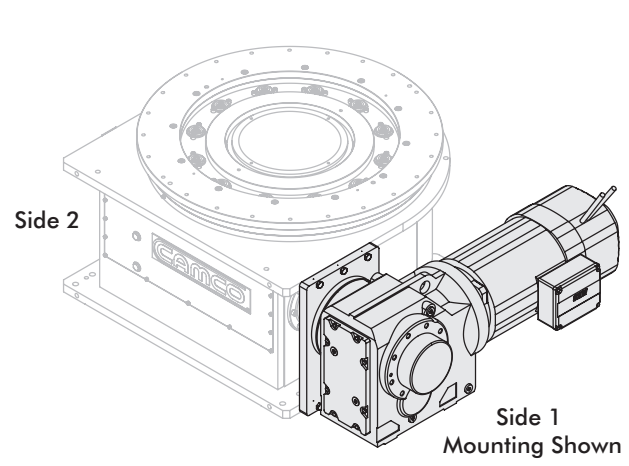
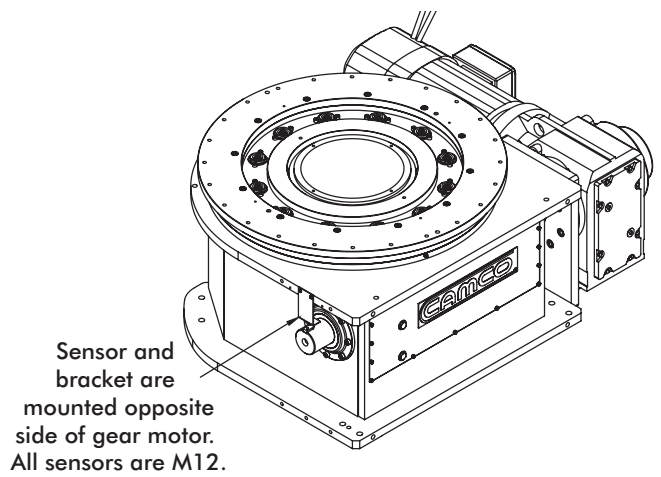

Figure 2: Sensor Mounting Position





MDE600M Series Indexer Sizing Tables

ND1 Gear Motor	Motion Time [†] [seconds]							
		2.24	2.43	2.88	3.19	3.55	4.20	4.46
Stops	Maximum Inertia* [Kgm ²]							
2	67	94	181	265	385	688	764	764
3	246	333	615	764	764	764	764	764
4	492	655	764	764	764	764	764	764
6	764	764	764	764	764	764	764	764
8	764	764	764	764	764	764	764	764
12	764	764	764	764	764	764	764	764
Reducer Ratio Options								
	A	B	C	D	E	F	G	H

Gear Motor Brake Option	
A or C	20 Nm
B or D	14 Nm

ND2 Gear Motor	Motion Time [†] [seconds]							
		2.11	2.40	2.60	2.89	3.28	3.66	4.47
Stops	Maximum Inertia* [Kgm ²]							
2	186	242	285	353	455	569	764	764
3	764	764	764	764	764	764	764	764
4	764	764	764	764	764	764	764	764
6	764	764	764	764	764	764	764	764
8	764	764	764	764	764	764	764	764
12	764	764	764	764	764	764	764	764
Reducer Ratio Options								
	A	B	C	D	E	F	G	H

Gear Motor Brake Option	
A or C	28 Nm
B or D	20 Nm

SW1 Gear Motor	Motion Time [†] [seconds]				
		1.61	1.84	2.18	2.41
Stops	Maximum Inertia* [Kgm ²]				
2	58	74	125	171	240
3	217	269	434	587	764
4	438	538	764	764	764
6	764	764	764	764	764
8	764	764	764	764	764
12	764	764	764	764	764
Reducer Ratio Options					
	A	B	C	D	E

Gear Motor Brake Option	
A or C	14 Nm
B or D	10 Nm

SW2 Gear Motor	Motion Time [†] [seconds]				
		2.45	2.80	2.95	3.36
Stops	Maximum Inertia* [Kgm ²]				
2	253	331	370	482	574
3	764	764	764	764	764
4	764	764	764	764	764
6	764	764	764	764	764
8	764	764	764	764	764
12	764	764	764	764	764
Reducer Ratio Options					
	A	B	C	D	E

Gear Motor Brake Option	
A or C	28 Nm
B or D	20 Nm

*Maximum Mass (Axial Load) used for charts is = 3182 kg
 †All motion times in tables are based on rated motor speed at 50 Hz

MDE600M Series Indexer Dimensions

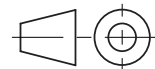
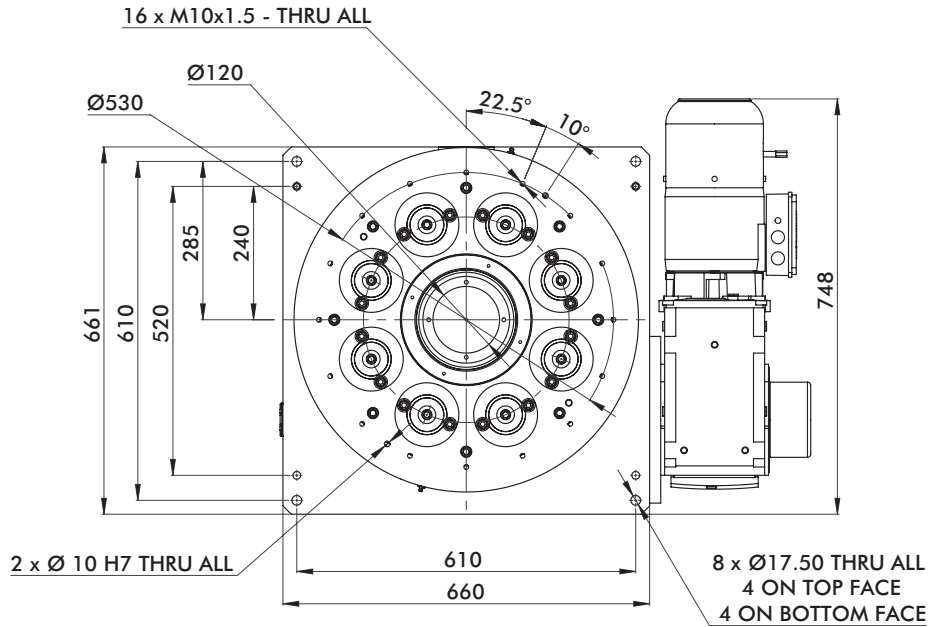
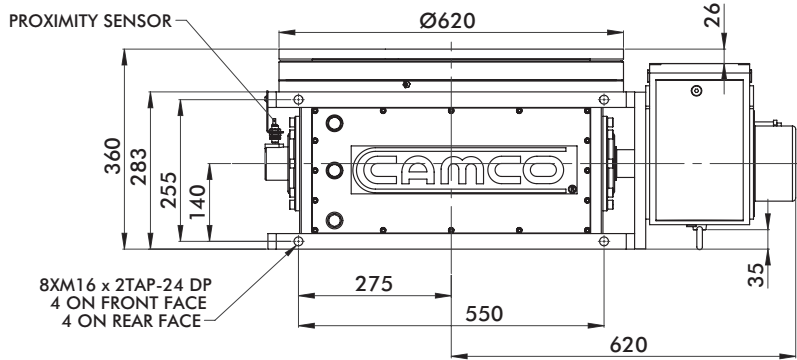
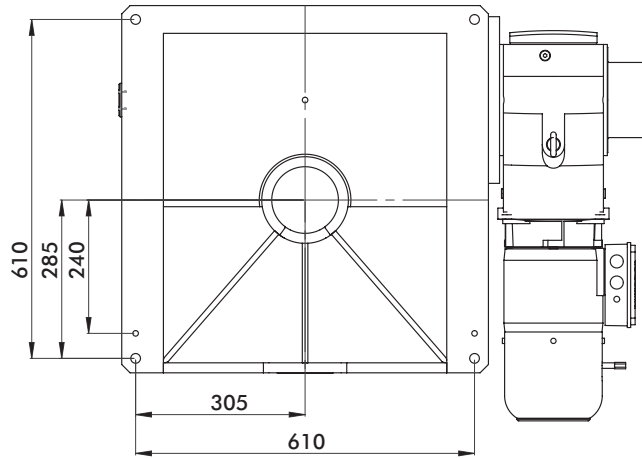

Unless otherwise noted, all dimensions are in mm.

Visit our website to download the specific cad model for your application.

MDE600M Series Indexer Specifications

Specifications

Main Dimensions	
Output Flange Diameter	620 mm
Height (Mounting surface of output flange)	360 mm
Center Opening	120 mm
Approximate Weight (Indexer)	650 Kg

Precision	
Indexing Accuracy	±35 arcsec
Indexing Repeatability	±6 arcsec
Axial Runout on Output Flange	0.02 mm
Radial Runout on Output Flange	0.02 mm

Load on Output Flange*	
Maximum Axial Force	31.3 kN
Maximum Radial Force	100 kN
Maximum Tilting Moment	6800 Nm
Maximum Output Torque (8-stop)	10000 Nm

*The specifications listed are simultaneous combined loading of maximum axial force, maximum radial force and maximum overturning moment.



Quick Access field replaceable cam followers

Horizontal Mounting

Vertical Mounting

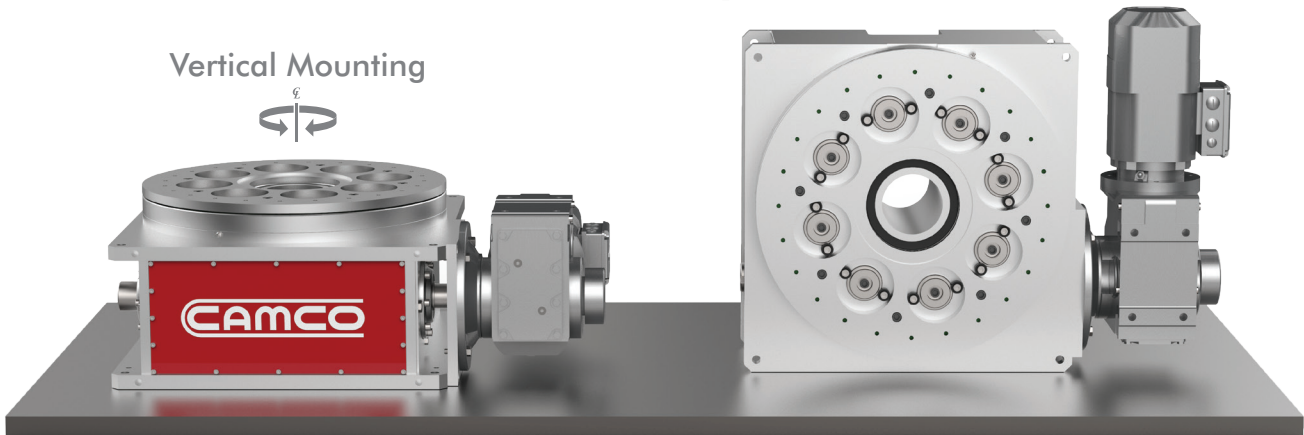

Consult Destaco for horizontal mounting applications

MDE700M Series Indexer How To Order



Motion	Number of Stops	Reducer Ratio	Gear Motor Ratios				Gear Motor Mount	(See Figure 1)	Dwell Sensor	(See figure 2)
			ND1	ND2	SW1	SW2				
A	2	A	59.17	55.69	64.75	56.64	1	Side 1	0	No Sensor
B	3	B	64.08	63.25	73.99	63.00	2	Side 2	A	Bracket for M12 Sensor only
C	4	C	75.91	68.61	78.07	70.46			B	PNP N/O w/Bracket Qty:1
D	6	D	84.17	76.18	88.97	79.34			C	PNP N/O w/Bracket Qty:2
E	8	E	93.50	86.43	97.05	86.34			D	NPN N/O w/Bracket Qty:1
F	12	F	110.77	95.96					E	NPN N/O w/Bracket Qty:2
G	16	G	117.70	117.79					F	PNP N/C w/Bracket Qty:1
		H	139.44	132.79					G	PNP N/C w/Bracket Qty:2
									H	NPN N/C w/Bracket Qty:1
									I	NPN N/C w/Bracket Qty:2

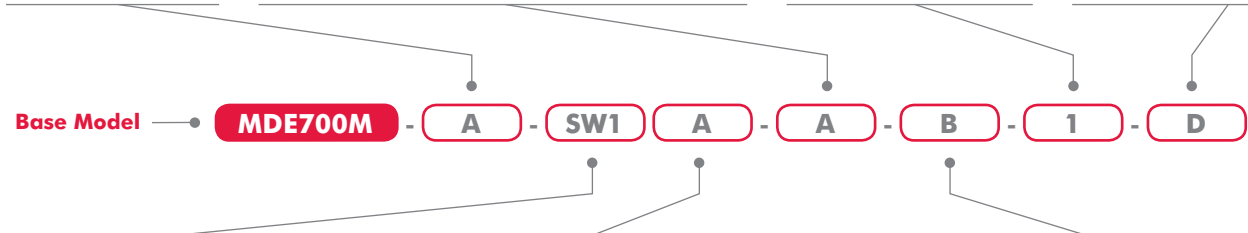

Gear Motor	Motor and Reducer	Motor Voltage	Description
ND1	NORD® 1.5 kW (2 hp)	A	400 VAC
ND2	NORD® 4.0 kW (5.4 hp)	B	460 VAC
SW1	SEW 3kW (4 hp)	C	575 VAC
SW2	SEW 5.6kW (7.5hp)		

Brake	Gear Motor Brake Options*			
	ND1	ND2	SW1	SW2
A	AC 20 Nm	AC 28 Nm	AC 28 Nm	AC 40 Nm
B	AC 14 Nm	AC 20 Nm	AC 20 Nm	AC 28 Nm
C	DC 20 Nm	DC 28 Nm	DC 28 Nm	DC 40 Nm
D	DC 14 Nm	DC 20 Nm	DC 20 Nm	DC 28 Nm

*AC = Uses same AC voltage as Motor (except 575 VAC requires 110 VAC for brake voltage)
 DC = Uses 24 VDC signal logic

Figure 1: Gear Motor Mounting Position

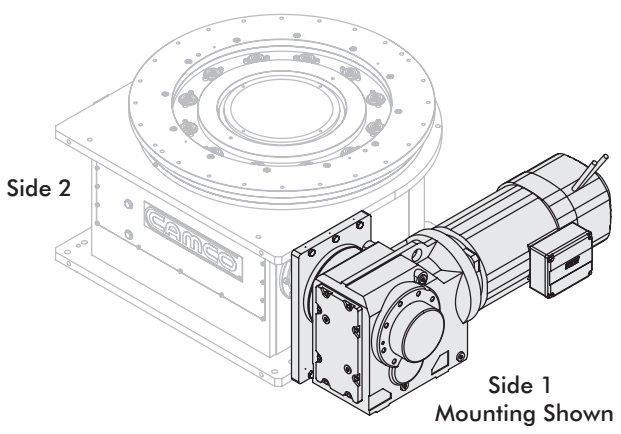
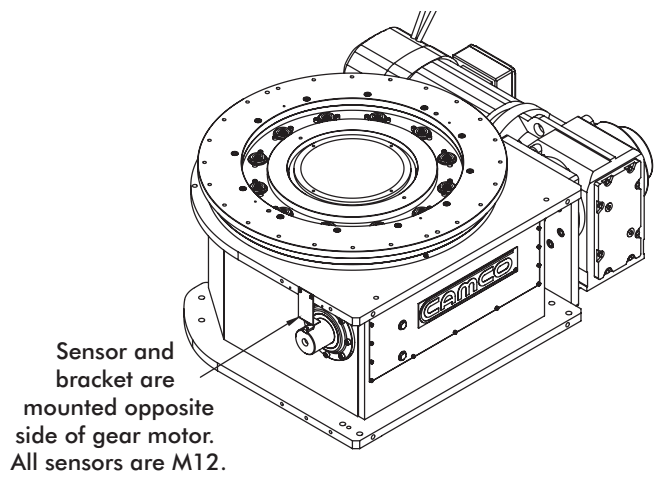

Figure 2: Sensor Mounting Position





MDE700M Series Indexer Sizing Tables

ND1		Motion Time [†] [seconds]							
Gear Motor		2.24	2.43	2.88	3.19	3.55	4.20	4.46	5.29
Stops		Maximum Inertia* [Kgm ²]							
2		8	25	85	148	241	487	616	962
3		100	150	320	486	728	1351	1673	1758
4		292	414	820	1214	1758	1758	1758	1758
6		752	1048	1758	1758	1758	1758	1758	1758
8		1590	1758	1758	1758	1758	1758	1758	1758
12		1758	1758	1758	1758	1758	1758	1758	1758
16		1758	1758	1758	1758	1758	1758	1758	1758

Gear Motor Brake Option	
A or C	20 Nm
B or D	14 Nm

Reducer Ratio Options								
A	B	C	D	E	F	G	H	

ND2		Motion Time [†] [seconds]							
Gear Motor		2.11	2.40	2.60	2.89	3.28	3.66	4.47	5.04
Stops		Maximum Inertia* [Kgm ²]							
2		146	191	226	281	365	457	684	871
3		436	566	667	825	1065	1330	1758	1758
4		1225	1758	1758	1758	1758	1758	1758	1758
6		1758	1758	1758	1758	1758	1758	1758	1758
8		1758	1758	1758	1758	1758	1758	1758	1758
12		1758	1758	1758	1758	1758	1758	1758	1758
16		1758	1758	1758	1758	1758	1758	1758	1758

Gear Motor Brake Option	
A or C	28 Nm
B or D	20 Nm

Reducer Ratio Options								
A	B	C	D	E	F	G	H	

SW1		Motion Time [†] [seconds]				
Gear Motor		2.45	2.80	2.95	3.36	3.67
Stops		Maximum Inertia* [Kgm ²]				
2		200	263	294	385	461
3		577	776	865	1127	1343
4		1372	1758	1758	1758	1758
6		1758	1758	1758	1758	1758
8		1758	1758	1758	1758	1758
12		1758	1758	1758	1758	1758
16		1758	1758	1758	1758	1758

Gear Motor Brake Option	
A or C	28 Nm
B or D	20 Nm

Reducer Ratio Options					
A	B	C	D	E	

SW2		Motion Time [†] [seconds]				
Gear Motor		2.14	2.38	2.66	3.00	3.26
Stops		Maximum Inertia* [Kgm ²]				
2		151	187	237	304	362
3		452	559	702	894	1061
4		1645	1758	1758	1758	1758
6		1758	1758	1758	1758	1758
8		1758	1758	1758	1758	1758
12		1758	1758	1758	1758	1758
16		1758	1758	1758	1758	1758

Gear Motor Brake Option	
A or C	40 Nm
B or D	28 Nm

Reducer Ratio Options					
A	B	C	D	E	

*Maximum Mass (Axial Load) used for charts is = 5682 kg
[†]All motion times in tables are based on rated motor speed at 50 Hz

MDE700M Series Indexer Dimensions

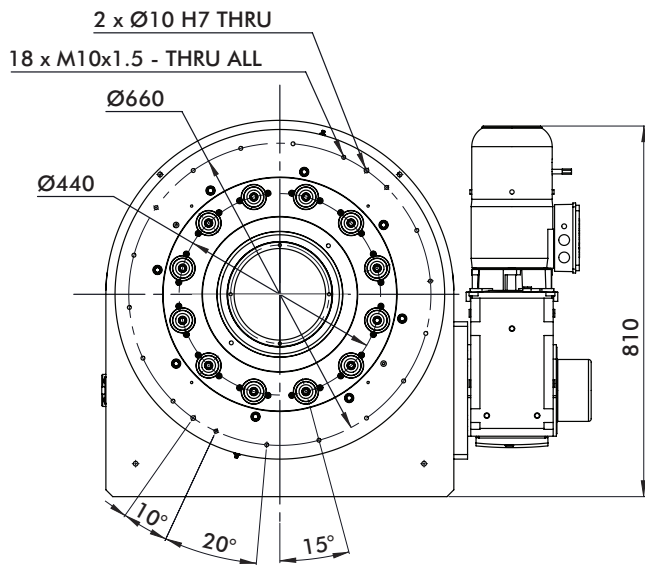
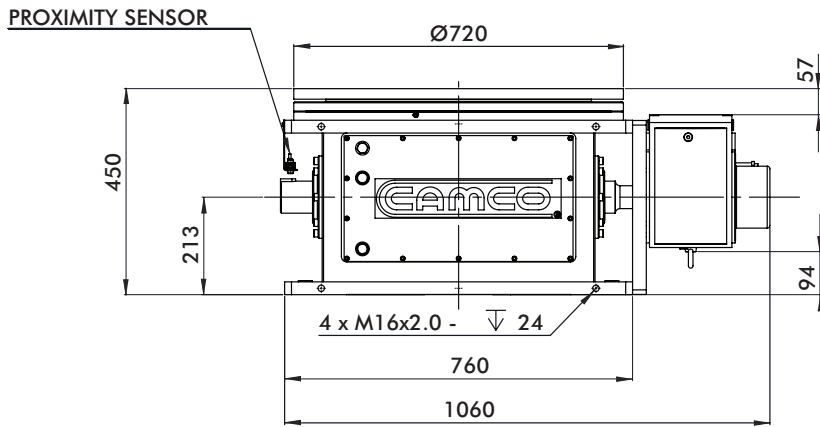
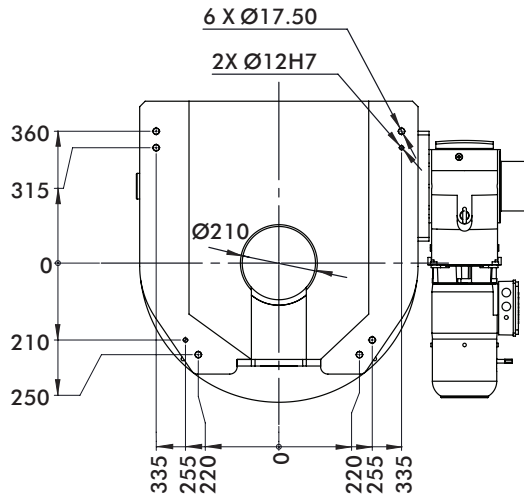

Visit our website to download the specific cad model for your application.

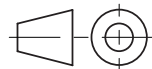

Unless otherwise noted, all dimensions are in mm.

MDE700M Series Indexer Technical Information

Specifications

Main Dimensions	
Output Flange Diameter	720 mm
Height (Mounting surface of output flange)	450 mm
Center Opening	210 mm
Approximate Weight (Indexer)	820 Kg

Precision

Indexing Accuracy	±27 arcsec
Indexing Repeatability	±6 arcsec
Axial Runout on Output Flange	0.02 mm
Radial Runout on Output Flange	0.02 mm

Load on Output Flange*

Maximum Axial Force	55.8 kN
Maximum Radial Force	100 kN
Maximum Tilting Moment	11.3 kNm
Maximum Output Torque (12-stop)	8400 Nm

*The specifications listed are simultaneous combined loading of maximum axial force, maximum radial force and maximum overturning moment.



Quick Access field replaceable cam followers

↕ Horizontal Mounting

Vertical Mounting

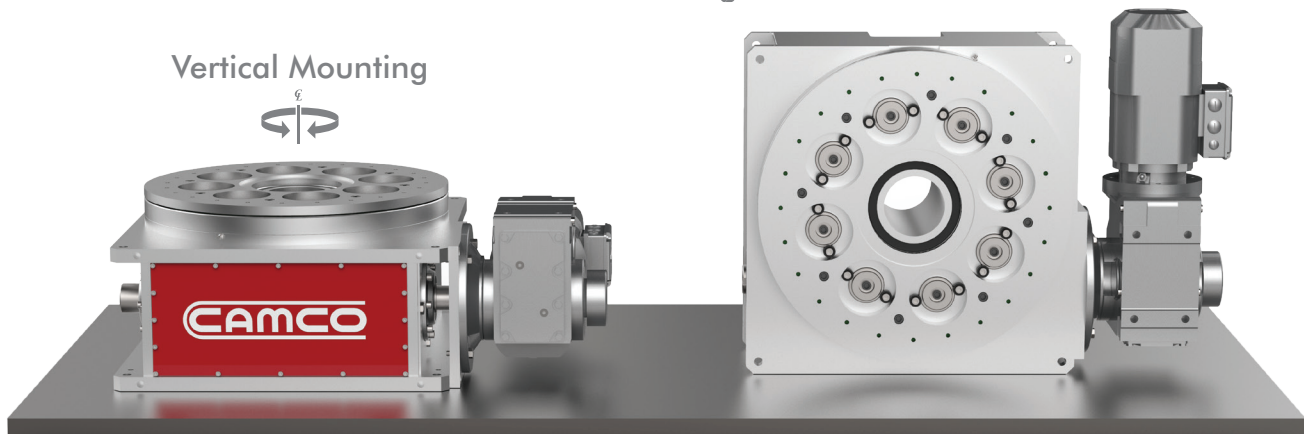

Consult Destaco for horizontal mounting applications

MDE900M Series Indexer How To Order



Motion	Number of Stops	Reducer Ratio	Gear Motor Ratios				Gear Motor Mount	Dwell Sensor (See figure 2)
			ND1	ND2	SW1	SW2		
A	2	A	55.69	54.56	56.64	41.87	1	0 No Sensor
B	3	B	63.25	62.42	63.00	47.93	2	A Bracket for M12 Sensor only
C	4	C	68.61	72.24	70.46	56.55		B PNP N/O w/Bracket Qty:1
D	6	D	76.18	88.17	79.34	62.55		C PNP N/O w/Bracket Qty:2
E	8	E	86.43	102.40	86.34	70.54		D NPN N/O w/Bracket Qty:1
F	12	F	95.96					E NPN N/O w/Bracket Qty:2
G	16	G	117.79					F PNP N/C w/Bracket Qty:1
		H	132.79					G PNP N/C w/Bracket Qty:2
								H NPN N/C w/Bracket Qty:1
								I NPN N/C w/Bracket Qty:2

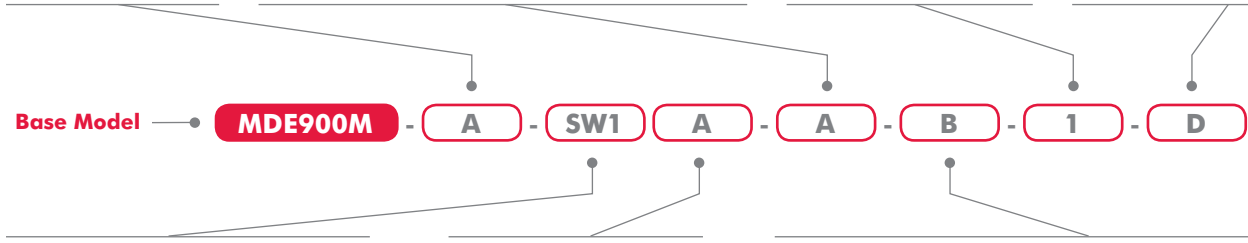

Gear Motor	Description	Motor Voltage	Description
ND1	NORD® 4 kW (5.4 hp)	A	400 VAC
ND2	NORD® 4 kW (5.4 hp)	B	460 VAC
SW1	SEW® 5.6 kW (7.5 hp)	C	575 VAC
SW2	SEW® 11 kW (14.8 hp)		

Brake	Gear Motor Brake Options*			
	ND1	ND2	SW1	SW2
A	AC 28 Nm	AC 40 Nm	AC 40 Nm	AC 110 Nm
B	AC 20 Nm	AC 28 Nm	AC 28 Nm	AC 80 Nm
C	DC 28 Nm	DC 40 Nm	DC 40 Nm	DC 110 Nm
D	DC 20 Nm	DC 28 Nm	DC 28 Nm	DC 80 Nm

*AC = Uses same AC voltage as Motor (except 575 VAC requires 110 VAC for brake voltage)
DC = Uses 24 VDC signal logic

Figure 1: Gear Motor Mounting Position

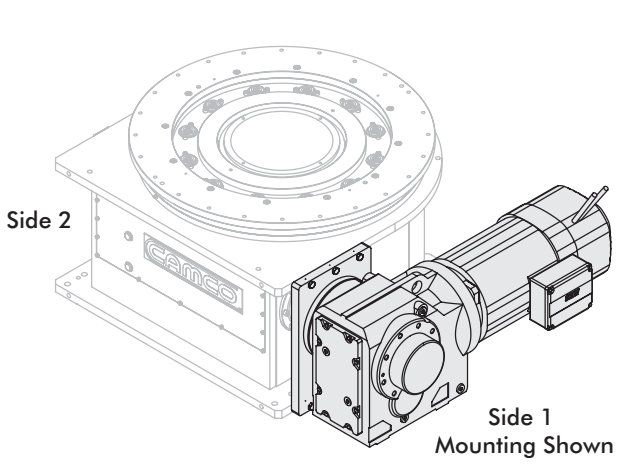
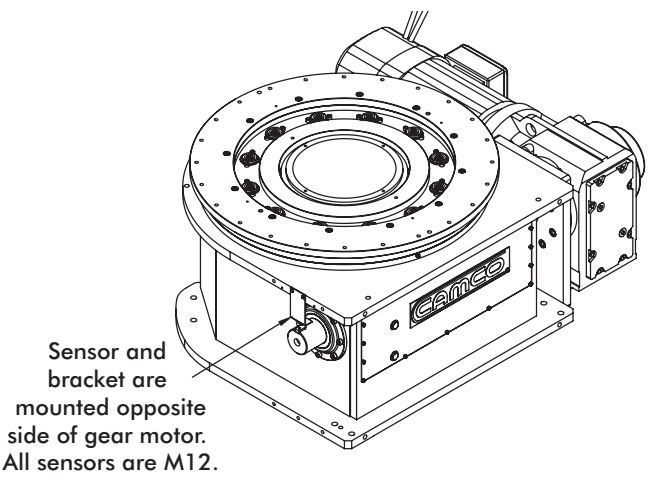

Figure 2: Sensor Mounting Position





MDE900M Series Indexer Sizing Tables

ND1 Gear Motor	Motion Time† [seconds]							
		2.11	2.40	2.60	2.89	3.28	3.66	4.47
Stops	Maximum Inertia* [Kgm ²]							
	2	116	210	256	323	425	538	817
3	397	643	866	1258	1873	2346	3507	3886
4	1006	1583	2103	3008	3886	3886	3886	3886
6	2488	3878	3886	3886	3886	3886	3886	3886
8	3886	3886	3886	3886	3886	3886	3886	3886
12	3886	3886	3886	3886	3886	3886	3886	3886
16	3886	3886	3886	3886	3886	3886	3886	3886

Gear Motor Brake Option	
A or C	28 Nm
B or D	20 Nm

Reducer Ratio Options								
A	B	C	D	E	F	G	H	

ND2 Gear Motor	Motion Time† [seconds]				
		2.07	2.37	2.74	3.34
Stops	Maximum Inertia* [Kgm ²]				
	2	104	198	287	443
3	366	611	1042	1950	2642
4	931	1509	2507	3886	3886
6	2316	3709	3886	3886	3886
8	3886	3886	3886	3886	3886
12	3886	3886	3886	3886	3886
16	3886	3886	3886	3886	3886

Gear Motor Brake Option	
A or C	40 Nm
B or D	28 Nm

Reducer Ratio Options				
A	B	C	D	E

SW1 Gear Motor	Motion Time† [seconds]				
		2.18	2.42	2.71	3.05
Stops	Maximum Inertia* [Kgm ²]				
	2	167	210	271	353
3	725	980	1234	1573	1869
4	1742	2486	3599	3886	3886
6	3886	3886	3886	3886	3886
8	3886	3886	3886	3886	3886
12	3886	3886	3886	3886	3886
16	3886	3886	3886	3886	3886

Gear Motor Brake Option	
A or C	40 Nm
B or D	28 Nm

Reducer Ratio Options				
A	B	C	D	E

SW2 Gear Motor	Motion Time† [seconds]				
		1.55	1.78	2.10	2.32
Stops	Maximum Inertia* [Kgm ²]				
	2	78	108	163	207
3	418	553	783	965	1237
4	1522	2356	3428	3886	3886
6	3679	3886	3886	3886	3886
8	3886	3886	3886	3886	3886
12	3886	3886	3886	3886	3886
16	3886	3886	3886	3886	3886

Gear Motor Brake Option	
A or C	110 Nm
B or D	80 Nm

Reducer Ratio Options				
A	B	C	D	E

*Maximum Mass (Axial Load) used for charts is = 6818 kg
 †All motion times in tables are based on rated motor speed at 50 Hz

MDE900M Series Indexer Dimensions

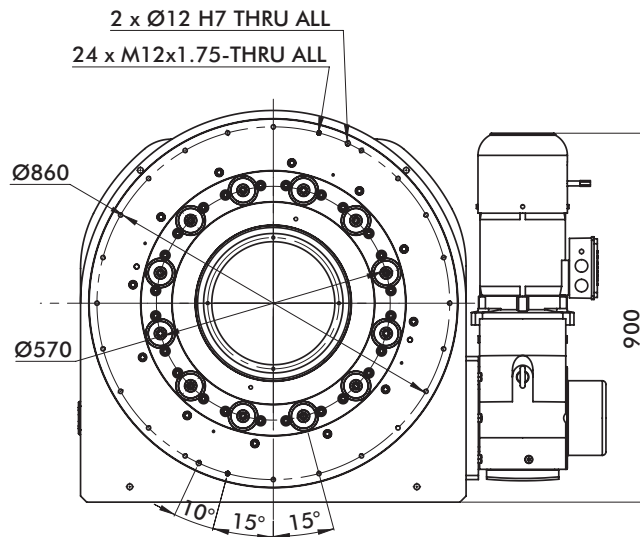
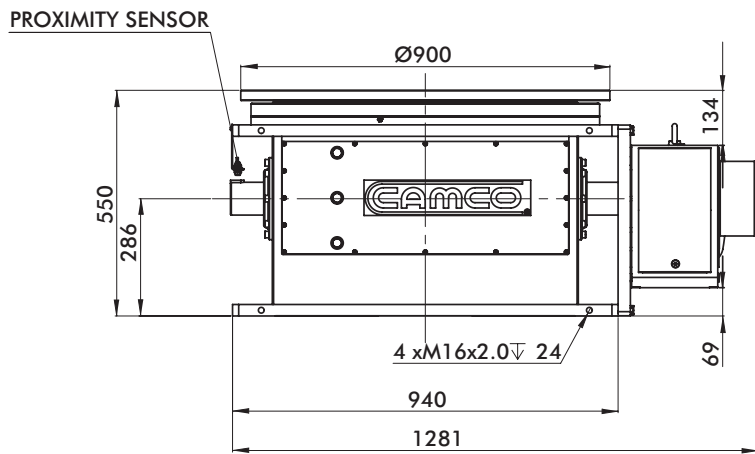
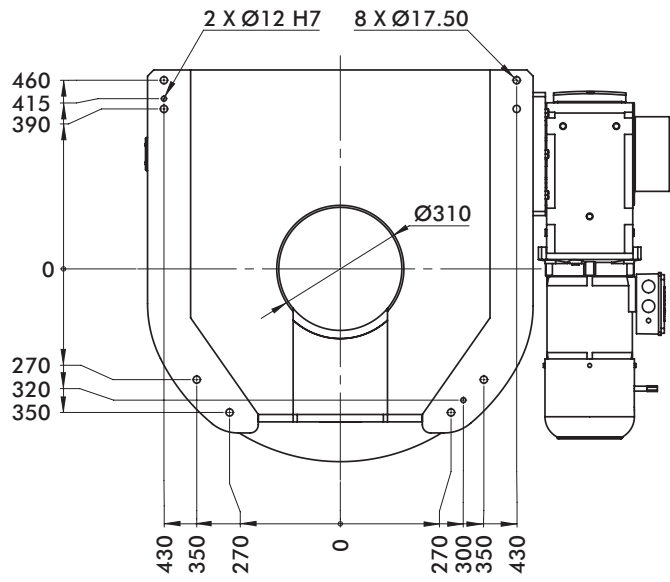

Visit our website to download the specific cad model for your application.

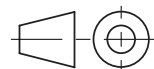

Unless otherwise noted, all dimensions are in mm.

MDE900M Series Indexer Technical Information

Specifications

Main Dimensions	
Output Flange Diameter	900 mm
Height (Mounting surface of output flange)	550 mm
Center Opening	300 mm
Approximate Weight (Indexer)	1300 Kg

Precision	
Indexing Accuracy	± 18 arcsec
Indexing Repeatability	± 6 arcsec
Axial Runout on Output Flange	0.02 mm
Radial Runout on Output Flange	0.02 mm

Load on Output Flange*	
Maximum Axial Force	66.7 kN
Maximum Radial Force	100 kN
Maximum Tilting Moment	16.9 kNm
Maximum Output Torque (12-stop)	16500 Nm

*The specifications listed are simultaneous combined loading of maximum axial force, maximum radial force and maximum overturning moment.



Quick Access field replaceable cam followers

Horizontal Mounting

Vertical Mounting

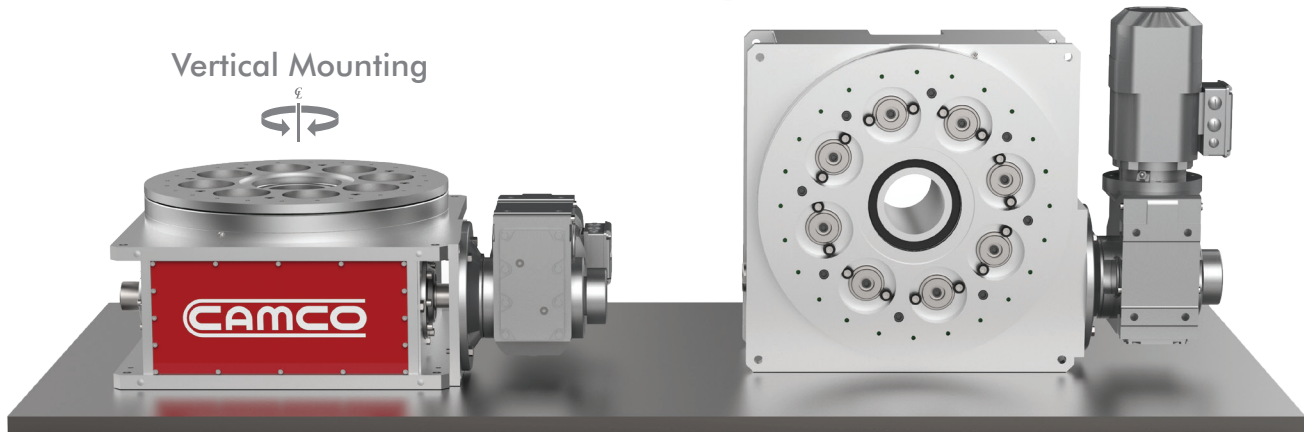

Consult Destaco for horizontal mounting applications

HDE1200M Series Indexer How To Order



Motion	Steps
A	2
B	3
C	4
D	6
E	8
F	12
G	16

Reducer Ratio

Reducer Ratio	ND1	ND2	SW1	SW2
A	36.21	41.11	41.87	57.17
B	39.72	44.81	47.93	66.52
C	44.96	50.35	56.55	73.30
D	54.56	58.44	62.55	82.61
E	62.42	70.22	70.54	90.96
F			100.75	

Gear Motor Ratios

Mount	(See Figure 1)
1	Side 1
2	Side 2

Dwell Sensor

(See figure 2)

0	No Sensor
A	Bracket for M12 Sensor only
B	PNP N/O w/Bracket Qty:1
C	PNP N/O w/Bracket Qty:2
D	NPN N/O w/Bracket Qty:1
E	NPN N/O w/Bracket Qty:2
F	PNP N/C w/Bracket Qty:1
G	PNP N/C w/Bracket Qty:2
H	NPN N/C w/Bracket Qty:1
I	NPN N/C w/Bracket Qty:2

Base Model → **HDE1200M** - **A** - **SW1** **A** - **A** - **B** - **1** - **D**

Gear Motor	Motor and Reducer
ND1	NORD 15kW (20.1 hp)
ND2	NORD 22kW (29.5 hp)
SW1	SEW 11kW (14.8 hp)
SW2	SEW 15kW (20.1 hp)

Voltage	Motor Voltage
A	400VAC Motor
B	460VAC Motor
C	575VAC Motor

Brake	Gear Motor Brake Options*			
	ND1	ND2	SW1	SW2
A	AC 150 Nm	AC 250 Nm	AC 110 Nm	AC 150 Nm
B	AC 85 Nm	AC 125 Nm	AC 80 Nm	AC 110 Nm
C	DC 150 Nm	DC 250 Nm	DC 110 Nm	DC 150 Nm
D	DC 85 Nm	DC 125 Nm	DC 80 Nm	DC 110 Nm

*AC = Uses same AC voltage as Motor (except 575 VAC requires 110 VAC for brake voltage)
DC = Uses 24 VDC signal logic

Figure 1: Gear Motor Mounting Position

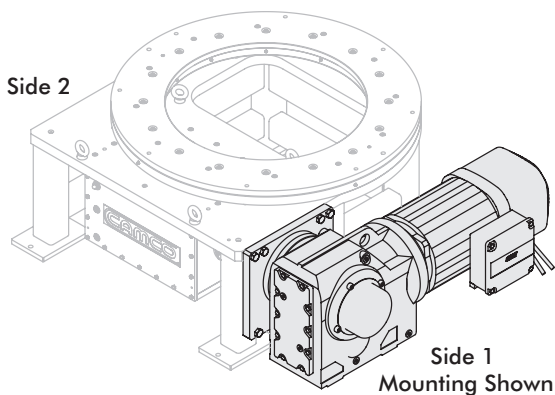
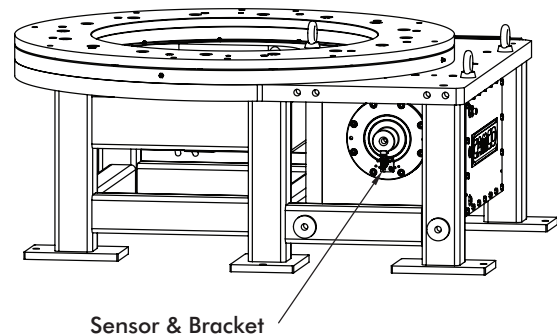

Figure 2: Sensor Mounting Position





HDE1200M Series Indexer Sizing Tables

ND1		Motion Time† [seconds]				
Gear Motor		1.36	1.50	1.69	2.06	2.35
Stops		Maximum Inertia* [Kgm ²]				
2		63	112	234	424	533
3		411	602	996	1643	2054
4		986	1397	2213	3574	4472
6		2400	3341	5170	8259	10344
8		4808	6594	10015	15874	19934
12		11729	14112	18098	21145	21145
16		14275	17764	21145	21145	21145

Reducer Ratio Options					
A	B	C	D	E	

ND2		Motion Time† [seconds]				
Gear Motor		1.55	1.69	1.90	2.20	2.65
Stops		Maximum Inertia* [Kgm ²]				
2		226	282	389	544	813
3		1341	1805	2698	3754	5447
4		2843	3620	4796	6589	9541
6		5860	7189	9450	12752	18439
8		9170	11241	14570	19650	21145
12		15133	17977	21145	21145	21145
16		19284	21145	21145	21145	21145

Reducer Ratio Options					
A	B	C	D	E	

SW1		Motion Time† [seconds]				
Gear Motor		1.55	1.78	2.10	2.32	2.62
Stops		Maximum Inertia* [Kgm ²]				
2		33	118	328	442	579
3		378	699	1393	1798	2304
4		966	1660	3109	3973	5070
6		2432	4030	7297	9275	11813
8		5035	8095	14249	18041	21145
12		12910	20280	21145	21145	21145
16		20138	21145	21145	21145	21145

Reducer Ratio Options					
A	B	C	D	E	

SW2		Motion Time† [seconds]					
Gear Motor		2.14	2.49	2.74	3.09	3.40	3.77
Stops		Maximum Inertia* [Kgm ²]					
2		530	723	891	1148	1405	1737
3		2441	4121	5676	7227	8775	10779
4		5155	8556	10402	13229	16051	19707
6		11691	16540	20097	21145	21145	21145
8		18814	21145	21145	21145	21145	21145
12		21145	21145	21145	21145	21145	21145
16		21145	21145	21145	21145	21145	21145

Reducer Ratio Options						
A	B	C	D	E	F	

Gear Motor Brake Option	
A or C	150 Nm
B or D	85 Nm

Gear Motor Brake Option	
A or C	250 Nm
B or D	125 Nm

Gear Motor Brake Option	
A or C	110 Nm
B or D	80 Nm

Gear Motor Brake Option	
A or C	150 Nm
B or D	110 Nm

*Maximum Mass (Axial Load) used for charts is = 14,091 kg
 †All motion times in tables are based on rated motor speed at 50 Hz

HDE1200M Series Indexer Dimensions

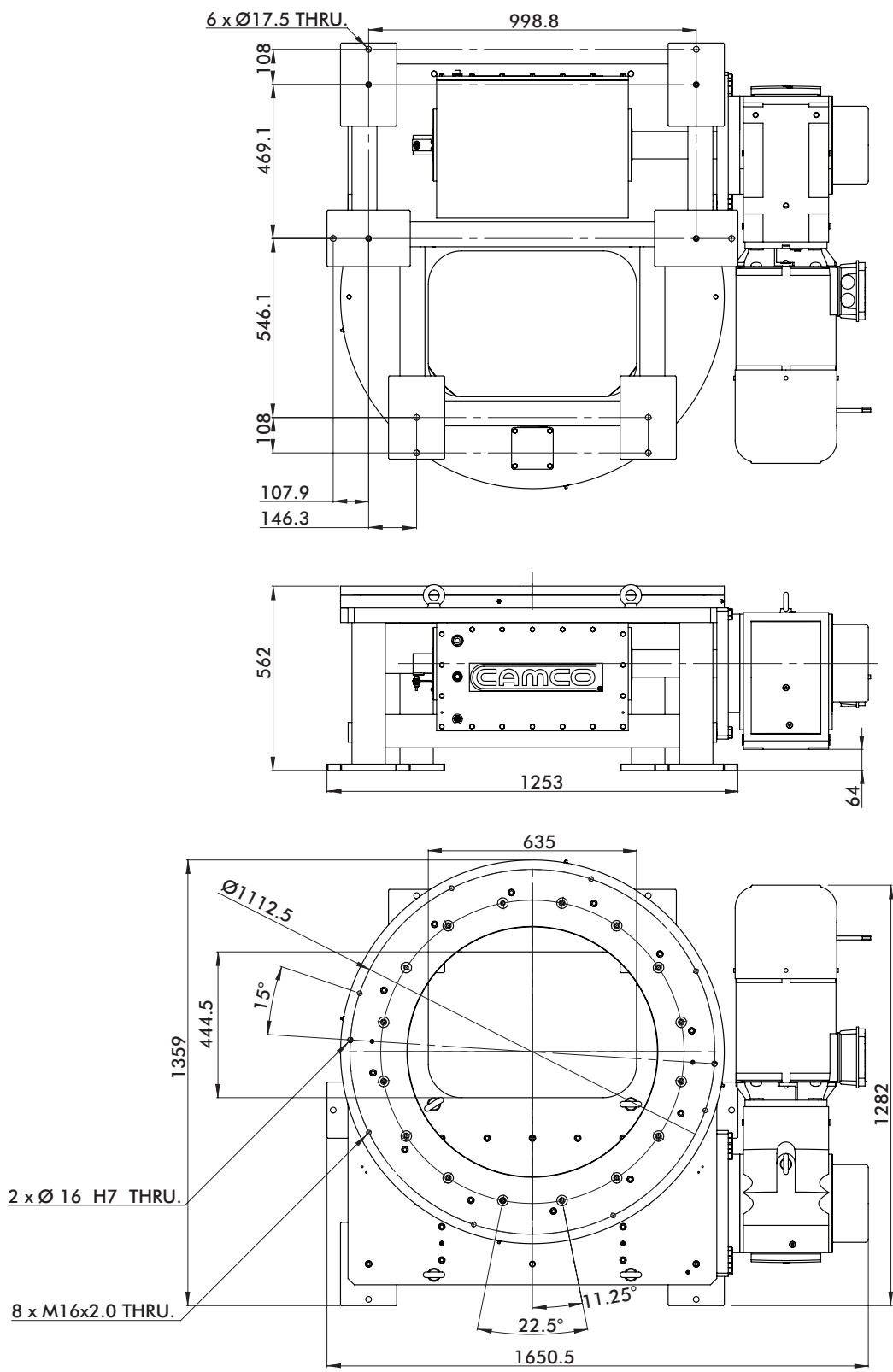

Visit our website to download the specific cad model for your application.



Unless otherwise noted, all dimensions are in mm.



HDE1200M Series Indexer Technical Information

Specifications

Main Dimensions	
Output Flange Diameter	1170 mm
Height (Mounting surface of output flange)	562 mm
Center Opening	445 x 635 mm
Approximate Weight (Indexer)	1790 Kg

Precision	
Indexing Accuracy	±11 arcsec
Indexing Repeatability	±3 arcsec
Axial Runout on Output Flange	0.02 mm
Radial Runout on Output Flange	0.02 mm

Load on Output Flange*	
Maximum Axial Force	142.4 kN
Maximum Radial Force	240 kN
Maximum Tilting Moment	6.8 kNm
Maximum Output Torque (12-stop)	27500 Nm

*The specifications listed are simultaneous combined loading of maximum axial force, maximum radial force and maximum overturning moment.

Industry's First Flex-Mount Indexing Solution



Flexible Mounting for custom height and width requirements.

HDE1200S Series Servo How To Order



Motion	Indexer Gear Ratio	Mount	(See Figure 1)	Adapter	ST1	ST2	SW1	SW2
B	32:1	1	Side 1	0	NONE	NONE	NONE	NONE
		2	Side 2	A	ST	ST	SW	SW
				B	AB	AB	AB	AB
				C	SIEM	SIEM	SIEM	SIEM

This adapter is a mounting plate attached to the planetary reducer that allows your choice of compatible servo motors.

Base Model → **HDE1200S** - **B** - **SW1** - **1** - **B** - **0**

Planetary Reducer	Description
000	No Planetary
ST1	STOBER 8:1 Ratio
ST2	STOBER 16:1 Ratio
SW1	SEW 7:1 Ratio
SW2	SEW 16:1 Ratio

Home Sensor	Description
0	No Sensor
A	Bracket for M12 Sensor
B	PNP N/O w/Bracket
C	NPN N/O w/Bracket
D	PNP N/C w/Bracket
E	NPN N/C w/Bracket

Sensor mounted on flat non-rotating surface above and on same side as planetary.

Gear Motor Mounting Position

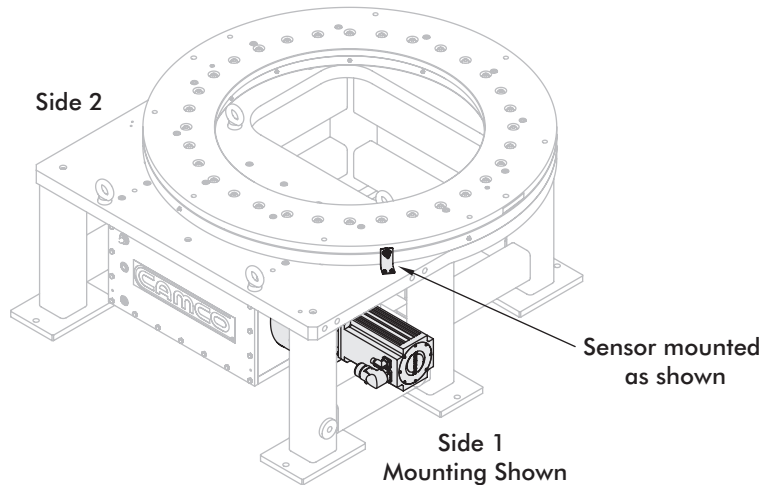



HDE1200S Series Servo Sizing Tables

ST1 Planetary Reducer	Motion Time [†] [seconds]			
	4	5	6	7
Stops	Maximum Inertia* [Kgm ²]			
2	2034	3196	4630	6326
3	3077	4826	6978	9520

ST2 Planetary Reducer	Motion Time [†] [seconds]			
	4	5	6	7
Stops	Maximum Inertia* [Kgm ²]			
4	4120	6456	9325	12715
6	6207	9716	14019	19104
8	8293	12976	18713	21145
12	12466	19496	21145	21145
16	16638	21145	21145	21145

SW1 Planetary Reducer	Motion Time [†] [seconds]			
	4	5	6	7
Stops	Maximum Inertia* [Kgm ²]			
2	3342	5240	7574	10332
3	5040	7892	11393	15530

SW2 Planetary Reducer	Motion Time [†] [seconds]			
	4	5	6	7
Stops	Maximum Inertia* [Kgm ²]			
4	4120	6456	9325	12715
6	6207	9716	14019	19104
8	8293	12976	18713	21145
12	12466	19496	21145	21145
16	16638	21145	21145	21145

*Based on 32:1 indexer gear ratio.

†All motion times in tables are based on rated motor speed at 50 Hz.

HDE1200S Series Servo Dimensions

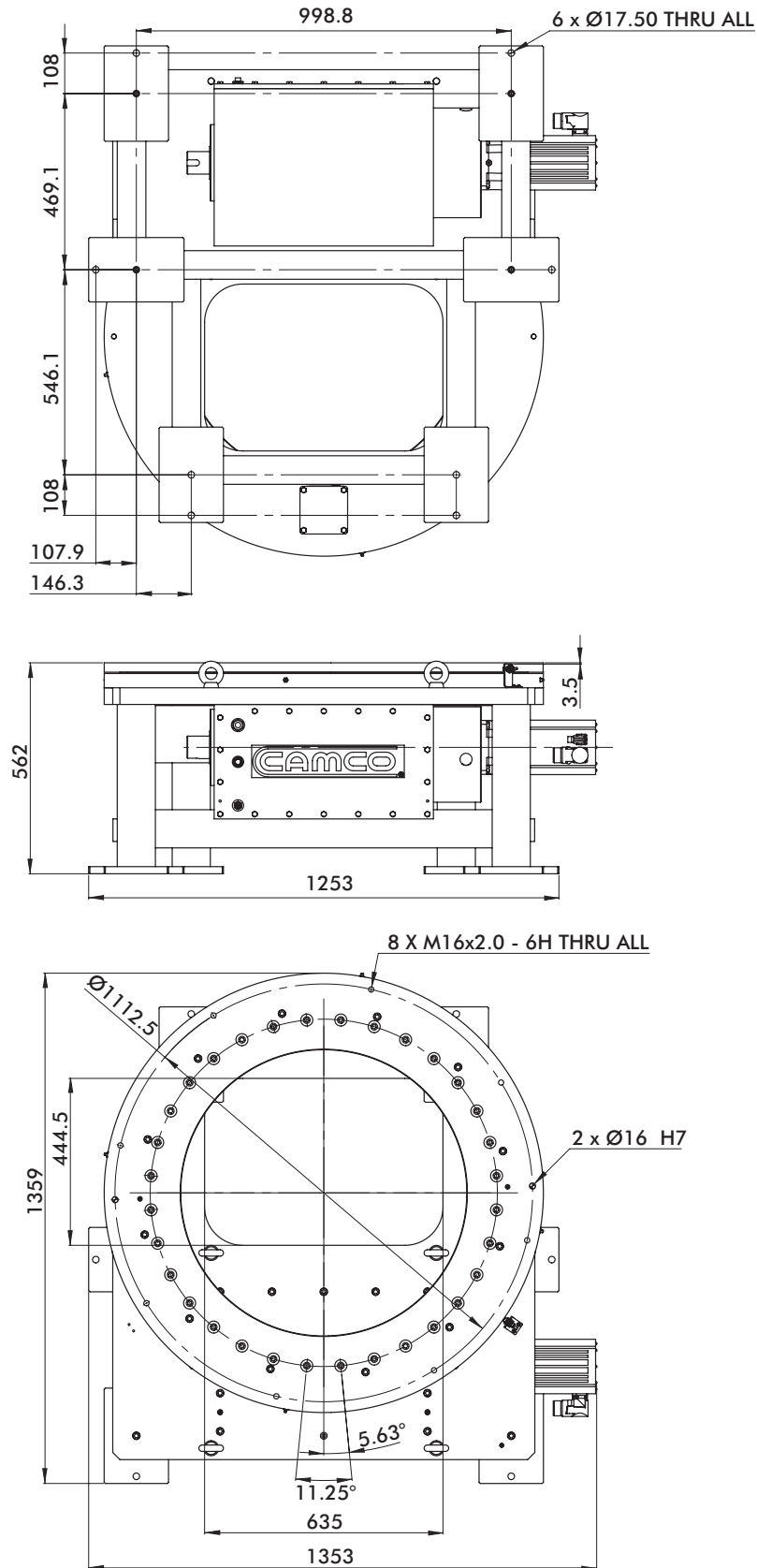

Visit our website to download the specific cad model for your application.

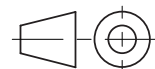

Unless otherwise noted, all dimensions are in mm.

HDE1200S Series Servo Technical Information

Specifications

Main Dimensions	
Output Flange Diameter	1170 mm
Height (Mounting surface of output flange)	562 mm
Center Opening	445 x 635 mm
Approximate Weight (Indexer)	1110 Kg

Precision	
Indexing Accuracy	±11 arcsec
Indexing Repeatability	±3 arcsec
Axial Runout on Output Flange	0.02 mm
Radial Runout on Output Flange	0.02 mm

Load on Output Flange*	
Maximum Axial Force	142.4 kN
Maximum Radial Force	240 kN
Maximum Tilting Moment	6.8 kNm
Maximum Output Torque (32:1 ratio)	17500 Nm

*The specifications listed are simultaneous combined loading of maximum axial force, maximum radial force and maximum overturning moment.

Industry's First Flex-Mount Indexing Solution



Flexible Mounting for custom height and width requirements.