



Vane pumps

Service information

vane-type triple pump / Flügelzellen-Dreifachpumpe

pompe triple à palettes / pompa tripla a palette

tipo bomba de paletas triple

T67DCC

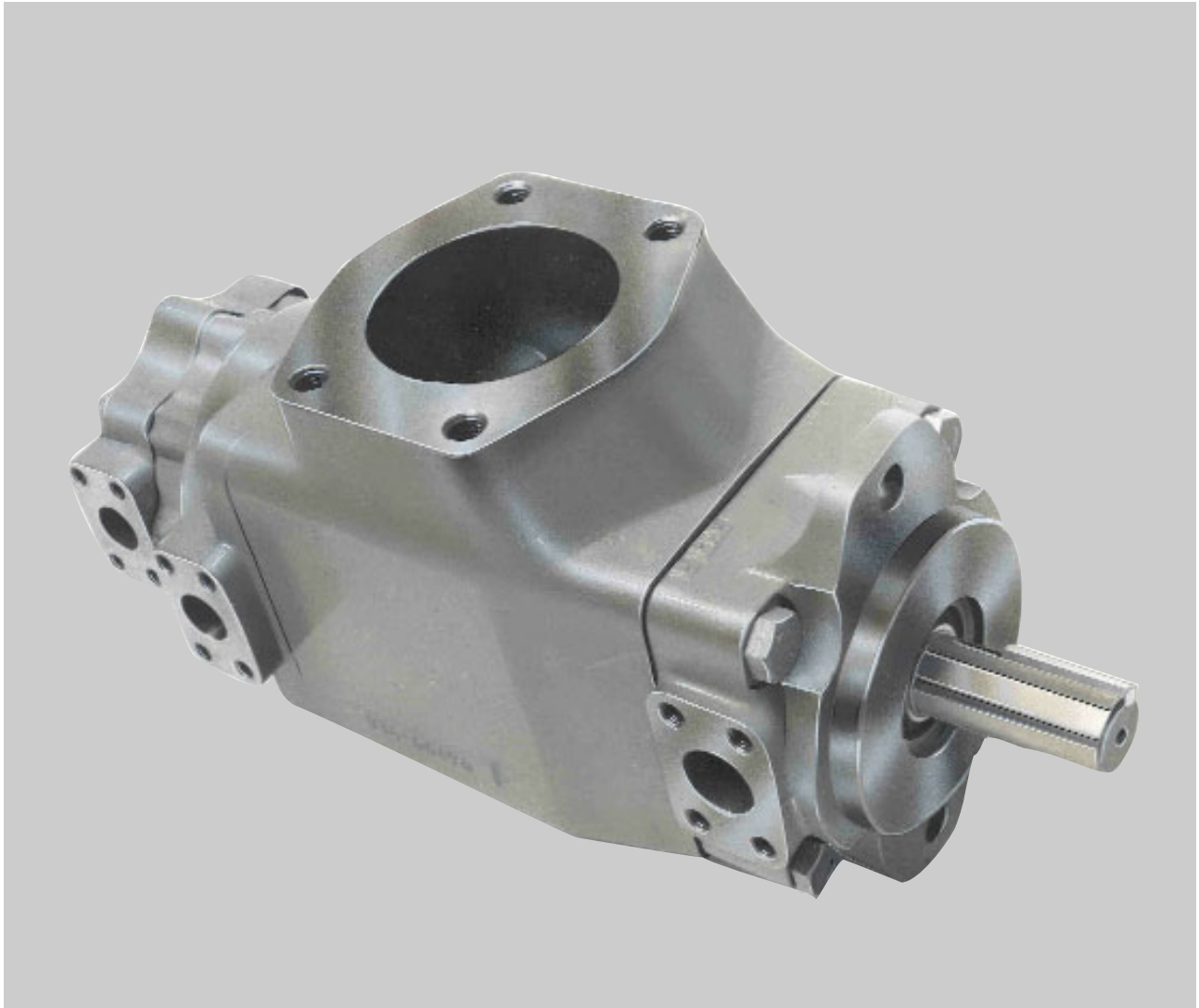

Recommended repair kits and assy's are bold printed
 Empfohlene Austausch - Baugruppen sind fett gedruckt
 Les pochettes de rechange recommandées sont imprimées en caractères gras
 I kit di ricambio consigliati sono indicati in grassetto
 Los juegos de reparacion recomendados y los conjuntos, estan en negrita

	Item - Pos. - Réf. - Pos.	
	42	43 - 46
Mounting torque		
Anziehdrehmoment	68 Nm	187 Nm
Couple de serrage	50 ft.lbs	138 ft.lbs
Coppia di serraggio		
Par de apriete		

T67DCC

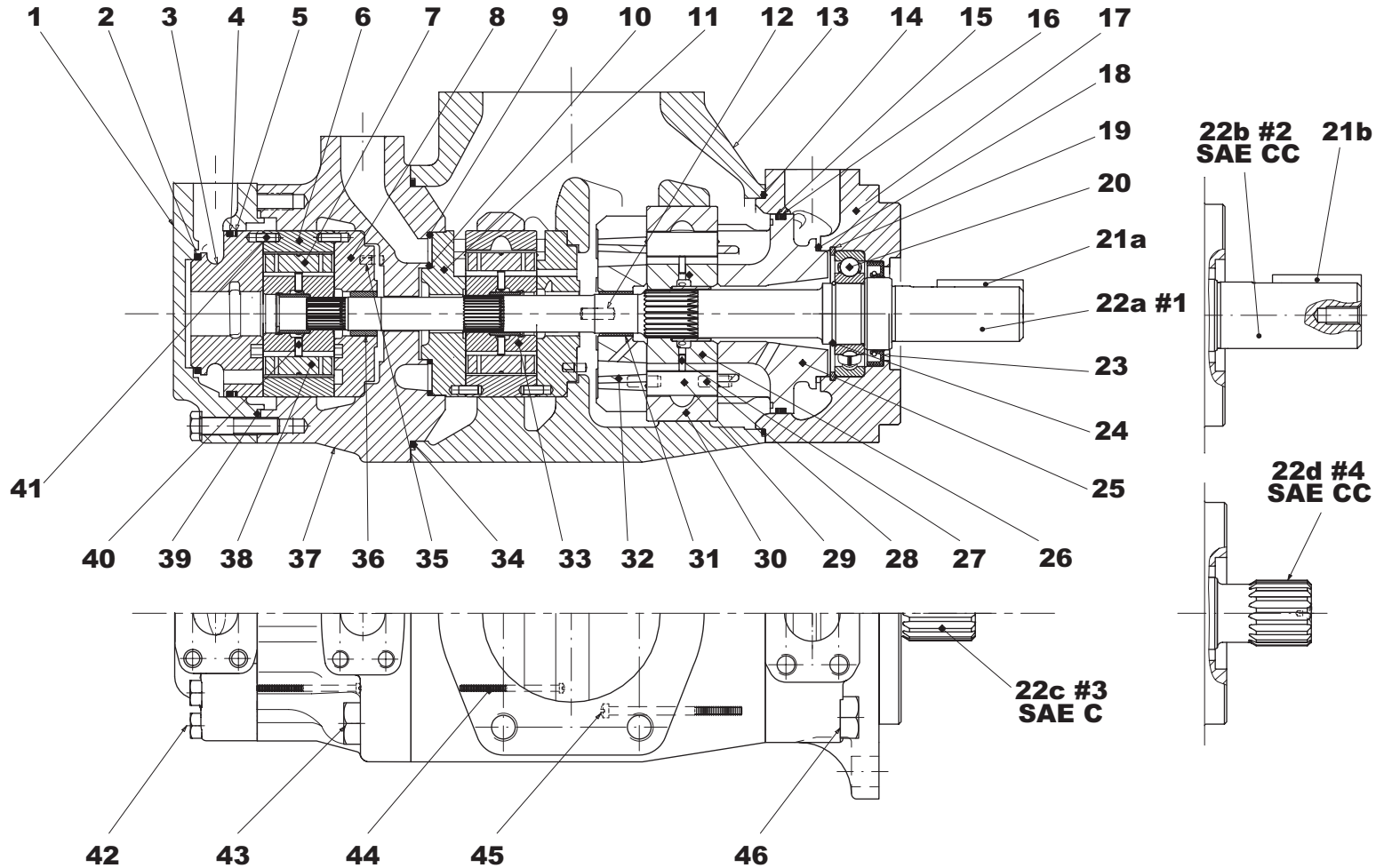

Item Pos. Réf. Pos.	Description Descrizione	Benennung Descrpcion	Description		Part N° Teil Nr. Code N° Cod. N° Referencia	Qty Stück Qté Q.tà Cant.	
1	End cap (metric 3/4") <i>Coperchio (metrica 3/4")</i>	Deckel (Metrisch 3/4") <i>Tapa (metrico 3/4")</i>	Chapeau (métrique 3/4")		034.66765	1	
	End cap (UNC 3/4") <i>Coperchio (UNC 3/4")</i>	Deckel (UNC 3/4") <i>Tapa (UNC 3/4")</i>	Chapeau (UNC 3/4")		034.66523	1	
	End cap (metric 1") <i>Coperchio (metrica 1")</i>	Deckel (Metrisch 1") <i>Tapa (metrico 1")</i>	Chapeau (métrique 1")		034.71327	1	
	End cap (UNC 1") <i>Coperchio (UNC 1")</i>	Deckel (UNC 1") <i>Tapa (UNC 1")</i>	Chapeau (UNC 1")		034.48579	1	
	Sq. section seal <i>Guarnizione</i>	Dichtring <i>Junta seccion cuadrada</i>	Joint section carrée	CD	691.10229	1	
	3	Port plate-pressure C.C.W. <i>Piatto distributore anter. antioraria</i>	Steuerplatte Linkslauf <i>Plato distribuidor-presión giro I</i>	Plaque press. rot. gauche	C	034.59773	1
Port plate-pressure C.W. <i>Piatto distributore anter. Oraria</i>		Steuerplatte Rechtslauf <i>Plato distribuidor-presión giro D</i>	Plaque press. rot. droite	CD	034.59772	1	
4	Sq. section seal <i>Guarnizione</i>	Dichtring <i>Junta seccion cuadrada</i>	Joint section carrée	CD	691.10238	1	
5	Back-up ring <i>Anello anti-estrusione</i>	Stützring <i>Anillo</i>	Bague anti-extrusion	CD	618.00010.3	1	
6	Cam ring 003 <i>Anello camma 003</i>	Hubring 003 <i>Aro volumetrico 003</i>	Came 003	BC	034.59050	2	
	Cam ring 005 <i>Anello camma 005</i>	Hubring 005 <i>Aro volumetrico 005</i>	Came 005	BC	034.59051	2	
	Cam ring 006 <i>Anello camma 006</i>	Hubring 006 <i>Aro volumetrico 006</i>	Came 006	BC	034.59052	2	
	Cam ring 008 <i>Anello camma 008</i>	Hubring 008 <i>Aro volumetrico 008</i>	Came 008	BC	034.59053	2	
	Cam ring 010 <i>Anello camma 010</i>	Hubring 010 <i>Aro volumetrico 010</i>	Came 010	BC	034.59054	2	
	Cam ring 012 <i>Anello camma 012</i>	Hubring 012 <i>Aro volumetrico 012</i>	Came 012	BC	034.66595	2	
	Cam ring 014 <i>Anello camma 014</i>	Hubring 014 <i>Aro volumetrico 014</i>	Came 014	BC	034.59206	2	
	Cam ring 017 <i>Anello camma 017</i>	Hubring 017 <i>Aro volumetrico 017</i>	Came 017	BC	034.59207	2	
	Cam ring 020 <i>Anello camma 020</i>	Hubring 020 <i>Aro volumetrico 020</i>	Came 020	BC	034.66607	2	
	Cam ring 022 <i>Anello camma 022</i>	Hubring 022 <i>Aro volumetrico 022</i>	Came 022	BC	034.59208	2	
	Cam ring 025 <i>Anello camma 025</i>	Hubring 025 <i>Aro volumetrico 025</i>	Came 025	BC	034.59209	2	
	Cam ring 028 <i>Anello camma 028</i>	Hubring 028 <i>Aro volumetrico 028</i>	Came 028	BC	034.59245	2	
	Cam ring 031 <i>Anello camma 031</i>	Hubring 031 <i>Aro volumetrico 031</i>	Came 031	BC	034.66843	2	
	7	Vane <i>Paletta</i>	Flügel <i>Paleta</i>	Palette	BC	034.59099	10
	8	Port plate-rear C.C.W. <i>Piatto distributore post. Antioraria</i>	Steuerplatte Linkslauf <i>Plato distribuidor trasero giro I</i>	Plaque arr. rotation gauche	BCM NPQ	034.59776	1
		Port plate-rear C.W. <i>Piatto distributore post. Oraria</i>	Steuerplatte Rechtslauf <i>Plato distribuidor trasero giro D</i>	Plaque arr. rotation droite	BCM NPQ	034.59777	1

Item Pos. Réf. Pos. Pos.	Description Descrizione	Benennung Descripción	Description		Part N° Teil Nr. Code N° Cod. N° Referencia	Qty Stück Qté Qtà Cant.
9	Sq. section seal <i>Guarnizione</i>	Dichtring <i>Junta seccion cuadrada</i>	Joint section carrée	BD	691.10153	1
10	Sq. section seal <i>Guarnizione</i>	Dichtring <i>Junta seccion cuadrada</i>	Joint section carrée	BD	691.10137	1
11	Port plate-pressure C.C.W. <i>Piatto distributore anter.antioraria</i>	Steuerplatte Linkslauf <i>Plato distribuidor-presión giro I</i>	Plaque press. rot. gauche	B	034.66522	1
	Port plate-pressure C.W. <i>Piatto distributore anter. Oraria</i>	Steuerplatte Rechtslauf <i>Plato distribuidor-presión giro D</i>	Plaque press. rot. droite	B	034.66521	1
12	Dowel pin <i>Spina</i>	Zentrierstift <i>Pasador</i>	Goupille	AJKL	323.82004	2
13	Housing (standard) (metric) <i>Corpo (standard) (metric)</i>	Gehäuse (Standard) (Metrisch) <i>Cuerpo (estándar) (metric)</i>	Carter (standard) (métrique)		034.66763	1
	Housing (standard) (UNC) <i>Corpo (standard) (UNC)</i>	Gehäuse (Standard) (UNC) <i>Cuerpo (estándar) (UNC)</i>	Carter (standard) (UNC)		034.66497	1
14	Sq. section seal <i>Guarnizione</i>	Dichtring <i>Junta seccion cuadrada</i>	Joint section carrée	AD	671.10159	1
15	Back-up ring <i>Anello anti-estrusione</i>	Stützring <i>Anillo</i>	Bague anti-extrusion	AD	618.00011.3	1
16	Sq. section seal <i>Guarnizione</i>	Dichtring <i>Junta seccion cuadrada</i>	Joint section carrée	AD	691.10244	1
17	Mounting cap (metric) <i>Coperchio (metric)</i>	Deckel (Metrisch) <i>Tapa de montaje 1" (metrico)</i>	Chapeau de montage (métrique)		034.66748	1
	Mounting cap (UNC) <i>Coperchio (UNC)</i>	Deckel (UNC) <i>Tapa de montaje (UNC)</i>	Chapeau de montage (UNC)		034.66495	1
18	Sq. section seal <i>Guarnizione</i>	Dichtring <i>Junta seccion cuadrada</i>	Joint section carrée	AD	691.10232	1
19	Retaining ring <i>Anello elastico</i>	Sicherungsring <i>Anillo de retención</i>	Circlips		356.32283	1
20	Ball bearing <i>Cuscinetto a sfere</i>	Kugellager <i>Cojinete de bolas</i>	Roulement à billes	EFGH	230.00207	1
21a	Key (code 1) <i>Chiavetta (codice 1)</i>	Paßfeder (Typ 1) <i>Chaveta (codigo 1)</i>	Clavette (code 1)	E	034.19579	1
21b	Key (code 2) <i>Chiavetta (codice 2)</i>	Paßfeder (Typ 2) <i>Chaveta (codigo 2)</i>	Clavette (code 2)	F	034.66981	1
22a	Shaft (keyed) (code1) <i>Albero a chiavetta (codice 1)</i>	Welle für Paßfeder (Typ 1) <i>Eje chaveteado (codigo 1)</i>	Arbre à clavette (code 1)	E	034.66500	1
22b	Shaft (keyed) (code 2) (SAE CC) <i>Albero a chiavetta (codice 2) (SAE CC)</i>	Welle für Paßfeder (Typ 2) (SAE CC) <i>Eje chaveteado (codigo 2) (SAE CC)</i>	Arbre à clavette (code 2) (SAE CC)	F	034.66513	1
22c	Shaft (splined) (code 3) (SAE C) <i>Albero a scanalato (codice 3) (SAE C)</i>	Vielkeilwelle (Typ 3) (SAE C) <i>Eje estriado (codigo 3) (SAE C)</i>	Arbre à cannelures (code 3) (SAE C)	G	034.66511	1
22d	Shaft (splined) (code 4) (SAE CC) <i>Albero scanalato (codice 4) (SAE CC)</i>	Vielkeilwelle (Typ 4) (SAE CC) <i>Eje estriado (codigo 4) (SAE CC)</i>	Arbre à cannelures (code 4) (SAE CC)	H	034.66514	1
23	Shaft seal (S1 - 0,7 bar) <i>Paraolio (S1 - 0,7 bar)</i>	Simmerring (S1 - 0,7 bar) <i>Reten eje (S1 - 0,7 bar)</i>	Joint d'arbre (S1 - 0,7 bar)	D	620.82064	1
	Shaft seal (S4 - S5 - 7 bar) <i>Paraolio (S4 - S5 - 7 bar)</i>	Simmerring (S4 - S5 - 7 bar) <i>Reten eje (S4 - S5 - 7 bar)</i>	Joint d'arbre (S4 - S5 - 7 bar)	D	620.82072	1
24	Round section ring <i>Anello elastico</i>	Sicherungsring <i>Anillo tórico</i>	Anneau	EFGH	034.70853	1
25	Port plate-pressure (Except cam rings 045 - 050) <i>Piatto distributore anter. (Eccetto anello camma 045-050)</i>	Steuerplatte (außer Hubringe 045-050) <i>Plato distribuidor-presión (Excepto los aros 045-050)</i>	Plaque pression (Excepté comes 045 - 050)	A	034.67479	1

Item Pos. Réf. Pos.	Description Descrizione	Benennung Descripcion	Description		Part N° Teil Nr. Code N° Cod. N° Referencia	Qty Stück Qté Q.tà Cant.	
25	Port plate-pressure C.C.W. (Only cam rings 045 - 050) <i>Piatto distributore anter. antioraria (Solo anello camma 045-050)</i>	Steuerplatte Linkslauf (nur Hubringe 045-050) <i>Plato distribuidor-presión giro I (Solo los aros 045-050)</i>	Plaque press. rot. G. (Seul. cames 045-050)	A	034.67113	1	
	Port plate-pressure C.W. (Only cam rings 045 - 050) <i>Piatto distributore anter. Oraria (Solo anello camma 045-050)</i>	Steuerplatte Rechtslauf (nur Hubringe 045-050) <i>Plato distribuidor-presión giro D (Solo los aros 045-050)</i>	Plaque press. rot. D. (Seul. cames 045-050)	A	034.67111	1	
26	Rotor ass'y (Except cam rings 045 - 050) <i>Insieme rotore (Eccetto anello camma 045-050)</i>	Rotor (außer Hubringe 045-050) <i>Conjunto rotor Excepto los aros 045-050)</i>	Rotor ass. (Excepté cames 045 - 050)	A	S24.73783	1	
	Rotor ass'y (Only cam ring 045 - 050) <i>Insieme rotore (Solo anello camma 045-050)</i>	Rotor (nur Hubringe 045-050) <i>Conjunto rotor (Solo los aros 045-050)</i>	Rotor ass. (Seul. cames 045-050)	A	S24.10121	1	
	Dowel pin <i>Spina</i>	Zentrierstift <i>Pasador</i>	Goupille	A	324.21612	2	
28	Pin-vane holdout (Except cam rings 045 - 050) <i>Pistoncino di sostentamento (Eccetto anello camma 045-050)</i>	Stössel (außer Hubringe 045-050) <i>Espiga empuje paleta (Excepto los aros 045-050)</i>	Poussoir de palette (Excepté cames 045 - 050)	A	034.59098	12	
	Pin-vane holdout (Only cam ring 045 - 050) <i>Pistoncino di sostentamento (Solo anello camma 045-050)</i>	Stössel (nur Hubringe 045-050) <i>Espiga empuje paleta (Solo los aros 045-050)</i>	Poussoir de palette (Seul. cames 045-050)	A	034.59130	10	
	Vane (Except cam rings 045 - 050) <i>Paletta (Eccetto anello camma 045-050)</i>	Flügel (außer Hubringe 045-050) <i>Paleta (Excepto los aros 045-050)</i>	Palette (Excepté cames 045 - 050)	A	034.67453	12	
29	Vane (Only cam ring 045 - 050) <i>Paletta (Solo anello camma 045-050)</i>	Flügel (nur Hubringe 045-050) <i>Paleta (Solo los aros 045-050)</i>	Palette (Seul. cames 045-050)	A	034.53588	10	
	Cam ring 014 <i>Anello camma 014</i>	Hubring 014 <i>Aro volumetrico 014</i>	Came 014	A	034.67469	1	
30	Cam ring 017 <i>Anello camma 017</i>	Hubring 017 <i>Aro volumetrico 017</i>	Came 017	A	034.67470	1	
	Cam ring 020 <i>Anello camma 020</i>	Hubring 020 <i>Aro volumetrico 020</i>	Came 020	A	034.67159	1	
	Cam ring 022 <i>Anello camma 022</i>	Hubring 022 <i>Aro volumetrico 022</i>	Came 022	A	034.67482	1	
	Cam ring 024 <i>Anello camma 024</i>	Hubring 024 <i>Aro volumetrico 024</i>	Came 024	A	034.67158	1	
	Cam ring 028 <i>Anello camma 028</i>	Hubring 028 <i>Aro volumetrico 028</i>	Came 028	A	034.67157	1	
	Cam ring 031 <i>Anello camma 031</i>	Hubring 031 <i>Aro volumetrico 031</i>	Came 031	A	034.67156	1	
	Cam ring 035 <i>Anello camma 035</i>	Hubring 035 <i>Aro volumetrico 035</i>	Came 035	A	034.67155	1	
	Cam ring 038 <i>Anello camma 038</i>	Hubring 038 <i>Aro volumetrico 038</i>	Came 038	A	034.67154	1	
	Cam ring 042 <i>Anello camma 042</i>	Hubring 042 <i>Aro volumetrico 042</i>	Came 042	A	034.67153	1	
	Cam ring 045 <i>Anello camma 045</i>	Hubring 045 <i>Aro volumetrico 045</i>	Came 045	A	034.59131	1	
	Cam ring 050 <i>Anello camma 050</i>	Hubring 050 <i>Aro volumetrico 050</i>	Came 050	A	034.66737	1	
	31	Bush <i>Bussola</i>	Buchse <i>Cojinete de fricción</i>	Bague	A	034.70868	1
		Port plate-rear (Except cam rings 045 - 050) <i>Piatto distributore post. (Eccetto anello camma 045-050)</i>	Steuerplatte (außer Hubringe 045-050) <i>Plato distribuidor trasero ((Excepto los aros 045-050)</i>	Plaque arrière (Excepté cames 045 - 050)	AJ	034.67478	1
	32	Port plate-rear C.C.W. (Only cam ring 045 - 050) <i>Piatto distributore post. Antioraria (Solo anello camma 045-050)</i>	Steuerplatte Linkslauf (nur Hubringe 045-050) <i>Plato distribuidor trasero giro I (Solo los aros 045-050)</i>	Plaque arr. rotation gauche (Seul. cames 045-050)	AL	034.67114	1
		Port plate-rear C.W. (Only cam ring 045 - 050) <i>Piatto distributore post. Oraria (Solo anello camma 045-050)</i>	Steuerplatte Rechtslauf (nur Hubringe 045-050) <i>Plato distribuidor trasero giro D (Solo los aros 045-050)</i>	Plaque arr. rotation droite (Seul. cames 045-050)	AK	034.67112	1

Item Pos. Réf. Pos. Pos.	Description Descrizione	Benennung Descripcion	Description		Part N° Teil Nr. Code N° Cod. N° Referencia	Qty Stück Qté Q.tà Cant.
33	Rotor ass'y <i>Insieme rotore</i>	Rotor <i>Conjunto rotor</i>	Rotor ass.	B	S24.10350	1
34	Sq. section seal <i>Guarnizione</i>	Dichtring <i>Junta seccion cuadrada</i>	Joint section carrée	BD	691.10256	1
35	Dowel pin <i>Spina</i>	Zentrierstift <i>Pasador</i>	Goupille	BCM NPQ	323.82010	1
36	Bush <i>Bussola</i>	Buchse <i>Cojinete de fricción</i>	Bague	CPQ	034.59412	1
37	Port block UNC <i>Corpo bocche UNC</i>	Anschlußblock UNC <i>Bloque distribuidor UNC</i>	Palier UNC		034.66499	1
	Port block metric <i>Corpo bocche metrica</i>	Anschlußblock Metrich <i>Bloque distribuidor metrico</i>	Palier métrique		034.66764	1
38	Rotor ass'y <i>Insieme rotore</i>	Rotor <i>Conjunto rotor</i>	Rotor ass.	C	S24.10116	1
39	Sq. section seal <i>Guarnizione</i>	Dichtring <i>Junta seccion cuadrada</i>	Joint section carrée	CD	671.10156	1
40	Pin-vane holdout <i>Pistoncino di sostentamento</i>	Stössel <i>Espiga empuje paleta</i>	Poussoir de palette	BC	034.59098	20
41	Dowel pin <i>Spina</i>	Zentrierstift <i>Pasador</i>	Goupille	BC	324.21208	4
42	Screw <i>Vite</i>	Schraube <i>Tornille</i>	Vis		306.40111	7
43	Screw <i>Vite</i>	Schraube <i>Tornille</i>	Vis		306.40154	4
44	Screw <i>Vite</i>	Schraube <i>Tornille</i>	Vis	BC	317.06266	4
45	Screw <i>Vite</i>	Schraube <i>Tornille</i>	Vis	A	317.10300.3	2
46	Screw <i>Vite</i>	Schraube <i>Tornille</i>	Vis		306.40156	4
	REPAIR KIT KIT DI RICAMBIO	AUSTAUSCH-BAUGRUPPEN CUNJUNTO REPARACION	POCHETTES RECHANGES			
A	Cart. and plate ass'y B14 C.W. (P1) <i>Ins. cart. B14 oraria (P1)</i>	Pumpeneinheit B14 Rechtslauf (P1) <i>Conjunto cart. y platos B14 giro d. (P1)</i>	Cart. et plaque ass. B14 rot. d. (P1)		S24.76312	1
A	Cart. and plate ass'y B14 C.C.W. (P1) <i>Ins. cart. B14 antioraria (P1)</i>	Pumpeneinheit B14 Linkslauf (P1) <i>Conjunto cart. y platos B14 giro i. (P1)</i>	Cart. et plaque ass. B14 rot. g. (P1)		S24.76313	1
A	Cart. and plate ass'y B17 C.W. (P1) <i>Ins. cart. B17 oraria (P1)</i>	Pumpeneinheit B17 Rechtslauf (P1) <i>Conjunto cart. y platos B17 giro d. (P1)</i>	Cart. et plaque ass. B17 rot. d. (P1)		S24.76314	1
A	Cart. and plate ass'y B17 C.C.W. (P1) <i>Ins. cart. B17 antioraria (P1)</i>	Pumpeneinheit B17 Linkslauf (P1) <i>Conjunto cart. y platos B17 giro i. (P1)</i>	Cart. et plaque ass. B17 rot. g. (P1)		S24.76315	1
A	Cart. and plate ass'y B20 C.W. (P1) <i>Ins. cart. B20 oraria (P1)</i>	Pumpeneinheit B20 Rechtslauf (P1) <i>Conjunto cart. y platos B20 giro d. (P1)</i>	Cart. et plaque ass. B20 rot. d. (P1)		S24.76316	1
A	Cart. and plate ass'y B20 C.C.W. (P1) <i>Ins. cart. B20 antioraria (P1)</i>	Pumpeneinheit B20 Linkslauf (P1) <i>Conjunto cart. y platos B20 giro i. (P1)</i>	Cart. et plaque ass. B20 rot. g. (P1)		S24.76317	1
A	Cart. and plate ass'y B22 C.W. (P1) <i>Ins. cart. B22 oraria (P1)</i>	Pumpeneinheit B22 Rechtslauf (P1) <i>Conjunto cart. y platos B22 giro d. (P1)</i>	Cart. et plaque ass. B22 rot. d. (P1)		S24.76318	1

Item Pos. Réf. Pos.	Description Descrizione	Benennung Descripcion	Description	Part N° Teil Nr. Code N° Cod. N° Referencia	Qty Stück Qté Q.tà Cant.
A	Cart. and plate ass'y B22 C.C.W. (P1) <i>Ins. cart. B22 antioraria (P1)</i>	Pumpeneinheit B22 Linkslauf (P1) <i>Conjunto cart. y platos B22 giro i. (P1)</i>	Cart. et plaque ass. B22 rot. g. (P1)	S24.76319	1
A	Cart. and plate ass'y B24 C.W. (P1) <i>Ins. cart. B24 oraria (P1)</i>	Pumpeneinheit B24 Rechtslauf (P1) <i>Conjunto cart. y platos B24 giro d. (P1)</i>	Cart. et plaque ass. B24 rot. d. (P1)	S24.76320	1
A	Cart. and plate ass'y B24 C.C.W. (P1) <i>Ins. cart. B24 antioraria (P1)</i>	Pumpeneinheit B24 Linkslauf (P1) <i>Conjunto cart. y platos B24 giro i. (P1)</i>	Cart. et plaque ass. B24 rot. g. (P1)	S24.76321	1
A	Cart. and plate ass'y B28 C.W. (P1) <i>Ins. cart. B28 oraria (P1)</i>	Pumpeneinheit B28 Rechtslauf (P1) <i>Conjunto cart. y platos B28 giro d. (P1)</i>	Cart. et plaque ass. B28 rot. d. (P1)	S24.76322	1
A	Cart. and plate ass'y B28 C.C.W. (P1) <i>Ins. cart. B28 antioraria (P1)</i>	Pumpeneinheit B28 Linkslauf (P1) <i>Conjunto cart. y platos B28 giro i. (P1)</i>	Cart. et plaque ass. B28 rot. g. (P1)	S24.76323	1
A	Cart. and plate ass'y B31 C.W. (P1) <i>Ins. cart. B31 oraria (P1)</i>	Pumpeneinheit B31 Rechtslauf (P1) <i>Conjunto cart. y platos B31 giro d. (P1)</i>	Cart. et plaque ass. B31 rot. d. (P1)	S24.76324	1
A	Cart. and plate ass'y B31 C.C.W. (P1) <i>Ins. cart. B31 antioraria (P1)</i>	Pumpeneinheit B31 Linkslauf (P1) <i>Conjunto cart. y platos B31 giro i. (P1)</i>	Cart. et plaque ass. B31 rot. g. (P1)	S24.76325	1
A	Cart. and plate ass'y B35 C.W. (P1) <i>Ins. cart. B35 oraria (P1)</i>	Pumpeneinheit B35 Rechtslauf (P1) <i>Conjunto cart. y platos B35 giro d. (P1)</i>	Cart. et plaque ass. B35 rot. d. (P1)	S24.76326	1
A	Cart. and plate ass'y B35 C.C.W. (P1) <i>Ins. cart. B35 antioraria (P1)</i>	Pumpeneinheit B35 Linkslauf (P1) <i>Conjunto cart. y platos B35 giro i. (P1)</i>	Cart. et plaque ass. B35 rot. g. (P1)	S24.76327	1
A	Cart. and plate ass'y B38 C.W. (P1) <i>Ins. cart. B38 oraria (P1)</i>	Pumpeneinheit B38 Rechtslauf (P1) <i>Conjunto cart. y platos B38 giro d. (P1)</i>	Cart. et plaque ass. B38 rot. d. (P1)	S24.76328	1
A	Cart. and plate ass'y B38 C.C.W. (P1) <i>Ins. cart. B38 antioraria (P1)</i>	Pumpeneinheit B38 Linkslauf (P1) <i>Conjunto cart. y platos B38 giro i. (P1)</i>	Cart. et plaque ass. B38 rot. g. (P1)	S24.76329	1
A	Cart. and plate ass'y B42 C.W. (P1) <i>Ins. cart. B42 oraria (P1)</i>	Pumpeneinheit B42 Rechtslauf (P1) <i>Conjunto cart. y platos B42 giro d. (P1)</i>	Cart. et plaque ass. B42 rot. d. (P1)	S24.76330	1
A	Cart. and plate ass'y B42 C.C.W. (P1) <i>Ins. cart. B42 antioraria (P1)</i>	Pumpeneinheit B42 Linkslauf (P1) <i>Conjunto cart. y platos B42 giro i. (P1)</i>	Cart. et plaque ass. B42 rot. g. (P1)	S24.76331	1
A	Cart. and plate ass'y 045 C.W. (P1) <i>Ins. cart. 045 oraria (P1)</i>	Pumpeneinheit 045 Rechtslauf (P1) <i>Conjunto cart. y platos 045 giro d. (P1)</i>	Cart. et plaque ass. 045 rot. d. (P1)	S24.10847	1
A	Cart. and plate ass'y 045 C.C.W. (P1) <i>Ins. cart. 045 antioraria (P1)</i>	Pumpeneinheit 045 Linkslauf (P1) <i>Conjunto cart. y platos 045 giro i. (P1)</i>	Cart. et plaque ass. 045 rot. g. (P1)	S24.10848	1
A	Cart. and plate ass'y 050 C.W. (P1) <i>Ins. cart. 050 oraria (P1)</i>	Pumpeneinheit 050 Rechtslauf (P1) <i>Conjunto cart. y platos 050 giro d. (P1)</i>	Cart. et plaque ass. 050 rot. d. (P1)	S24.40028	1
A	Cart. and plate ass'y 050 C.C.W. (P1) <i>Ins. cart. 050 antioraria (P1)</i>	Pumpeneinheit 050 Linkslauf (P1) <i>Conjunto cart. y platos 050 giro i. (P1)</i>	Cart. et plaque ass. 050 rot. g. (P1)	S24.40029	1
B	Cart. and plate ass'y 003 C.W. (P2) <i>Ins. cart. 003 oraria (P2)</i>	Pumpeneinheit 003 Rechtslauf (P2) <i>Conjunto cart. y platos 003 giro d. (P2)</i>	Cart. et plaque ass. 003 rot. d. (P2)	S24.25551	1
B	Cart. and plate ass'y 003 C.C.W. (P2) <i>Ins. cart. 003 antioraria (P2)</i>	Pumpeneinheit 003 Linkslauf (P2) <i>Conjunto cart. y platos 003 giro i. (P2)</i>	Cart. et plaque ass. 003 rot. g. (P2)	S24.25561	1
B	Cart. and plate ass'y 005 C.W. (P2) <i>Ins. cart. 005 oraria (P2)</i>	Pumpeneinheit 005 Rechtslauf (P2) <i>Conjunto cart. y platos 005 giro d. (P2)</i>	Cart. et plaque ass. 005 rot. d. (P2)	S24.25552	1
B	Cart. and plate ass'y 005 C.C.W. (P2) <i>Ins. cart. 005 antioraria (P2)</i>	Pumpeneinheit 005 Linkslauf (P2) <i>Conjunto cart. y platos 005 giro i. (P2)</i>	Cart. et plaque ass. 005 rot. g. (P2)	S24.25562	1
B	Cart. and plate ass'y 006 C.W. (P2) <i>Ins. cart. 006 oraria (P2)</i>	Pumpeneinheit 006 Rechtslauf (P2) <i>Conjunto cart. y platos 006 giro d. (P2)</i>	Cart. et plaque ass. 006 rot. d. (P2)	S24.25553	1
B	Cart. and plate ass'y 006 C.C.W. (P2) <i>Ins. cart. 006 antioraria (P2)</i>	Pumpeneinheit 006 Linkslauf (P2) <i>Conjunto cart. y platos 006 giro i. (P2)</i>	Cart. et plaque ass. 006 rot. g. (P2)	S24.25563	1
B	Cart. and plate ass'y 008 C.W. (P2) <i>Ins. cart. 008 oraria (P2)</i>	Pumpeneinheit 008 Rechtslauf (P2) <i>Conjunto cart. y platos 008 giro d. (P2)</i>	Cart. et plaque ass. 008 rot. d. (P2)	S24.25554	1
B	Cart. and plate ass'y 008 C.C.W. (P2) <i>Ins. cart. 008 antioraria (P2)</i>	Pumpeneinheit 008 Linkslauf (P2) <i>Conjunto cart. y platos 008 giro i. (P2)</i>	Cart. et plaque ass. 008 rot. g. (P2)	S24.25564	1

Item Pos. Réf. Pos.	Description <i>Descrizione</i>	Benennung <i>Descripcion</i>	Description	Part N° Teil Nr. Code N° Cod. N° Referencia	Qty Stück Qté Q.tà Cant.
B	Cart. and plate ass'y 010 C.W. (P2) Ins. cart. 010 oraria (P2)	Pumpeneinheit 010 Rechtslauf (P2) Conjunto cart. y platos 010 giro d. (P2)	Cart. et plaque ass. 010 rot. d. (P2)	S24.25555	1
B	Cart. and plate ass'y 010 C.C.W. (P2) Ins. cart. 010 antioraria (P2)	Pumpeneinheit 010 Linkslauf (P2) Conjunto cart. y platos 010 giro i. (P2)	Cart. et plaque ass. 010 rot. g. (P2)	S24.25565	1
B	Cart. and plate ass'y 012 C.W. (P2) Ins. cart. 012 oraria (P2)	Pumpeneinheit 012 Rechtslauf (P2) Conjunto cart. y platos 012 giro d. (P2)	Cart. et plaque ass. 012 rot. d. (P2)	S24.26484	1
B	Cart. and plate ass'y 012 C.C.W. (P2) Ins. cart. 012 antioraria (P2)	Pumpeneinheit 012 Linkslauf (P2) Conjunto cart. y platos 012 giro i. (P2)	Cart. et plaque ass. 012 rot. g. (P2)	S24.26485	1
B	Cart. and plate ass'y 014 C.W. (P2) Ins. cart. 014 oraria (P2)	Pumpeneinheit 014 Rechtslauf (P2) Conjunto cart. y platos 014 giro d. (P2)	Cart. et plaque ass. 014 rot. d. (P2)	S24.25556	1
B	Cart. and plate ass'y 014 C.C.W. (P2) Ins. cart. 014 antioraria (P2)	Pumpeneinheit 014 Linkslauf (P2) Conjunto cart. y platos 014 giro i. (P2)	Cart. et plaque ass. 014 rot. g. (P2)	S24.25566	1
B	Cart. and plate ass'y 017 C.W. (P2) Ins. cart. 017 oraria (P2)	Pumpeneinheit 017 Rechtslauf (P2) Conjunto cart. y platos 017 giro d. (P2)	Cart. et plaque ass. 017 rot. d. (P2)	S24.25557	1
B	Cart. and plate ass'y 017 C.C.W. (P2) Ins. cart. 017 antioraria (P2)	Pumpeneinheit 017 Linkslauf (P2) Conjunto cart. y platos 017 giro i. (P2)	Cart. et plaque ass. 017 rot. g. (P2)	S24.25567	1
B	Cart. and plate ass'y 020 C.W. (P2) Ins. cart. 020 oraria (P2)	Pumpeneinheit 020 Rechtslauf (P2) Conjunto cart. y platos 020 giro d. (P2)	Cart. et plaque ass. 020 rot. d. (P2)	S24.40352	1
B	Cart. and plate ass'y 020 C.C.W. (P2) Ins. cart. 020 antioraria (P2)	Pumpeneinheit 020 Linkslauf (P2) Conjunto cart. y platos 020 giro i. (P2)	Cart. et plaque ass. 020 rot. g. (P2)	S24.40353	1
B	Cart. and plate ass'y 022 C.W. (P2) Ins. cart. 022 oraria (P2)	Pumpeneinheit 022 Rechtslauf (P2) Conjunto cart. y platos 022 giro d. (P2)	Cart. et plaque ass. 022 rot. d. (P2)	S24.25558	1
B	Cart. and plate ass'y 022 C.C.W. (P2) Ins. cart. 022 antioraria (P2)	Pumpeneinheit 022 Linkslauf (P2) Conjunto cart. y platos 022 giro i. (P2)	Cart. et plaque ass. 022 rot. g. (P2)	S24.25568	1
B	Cart. and plate ass'y 025 C.W. (P2) Ins. cart. 025 oraria (P2)	Pumpeneinheit 025 Rechtslauf (P2) Conjunto cart. y platos 025 giro d. (P2)	Cart. et plaque ass. 025 rot. d. (P2)	S24.25559	1
B	Cart. and plate ass'y 025 C.C.W. (P2) Ins. cart. 025 antioraria (P2)	Pumpeneinheit 025 Linkslauf (P2) Conjunto cart. y platos 025 giro i. (P2)	Cart. et plaque ass. 025 rot. g. (P2)	S24.25569	1
B	Cart. and plate ass'y 028 C.W. (P2) Ins. cart. 028 oraria (P2)	Pumpeneinheit 028 Rechtslauf (P2) Conjunto cart. y platos 028 giro d. (P2)	Cart. et plaque ass. 028 rot. d. (P2)	S24.25560	1
B	Cart. and plate ass'y 028 C.C.W. (P2) Ins. cart. 028 antioraria (P2)	Pumpeneinheit 028 Linkslauf (P2) Conjunto cart. y platos 028 giro i. (P2)	Cart. et plaque ass. 028 rot. g. (P2)	S24.25570	1
B	Cart. and plate ass'y 031 C.W. (P2) Ins. cart. 031 oraria (P2)	Pumpeneinheit 031 Rechtslauf (P2) Conjunto cart. y platos 031 giro d. (P2)	Cart. et plaque ass. 031 rot. d. (P2)	S24.45773	1
B	Cart. and plate ass'y 031 C.C.W. (P2) Ins. cart. 031 antioraria (P2)	Pumpeneinheit 031 Linkslauf (P2) Conjunto cart. y platos 031 giro i. (P2)	Cart. et plaque ass. 031 rot. g. (P2)	S24.45774	1
C	Cart. and plate ass'y 003 C.W. (P3) Ins. cart. 003 oraria (P3)	Pumpeneinheit 003 Rechtslauf (P3) Conjunto cart. y platos 003 giro d. (P3)	Cart. et plaque ass. 003 rot. d. (P3)	S24.10749	1
C	Cart. and plate ass'y 003 C.C.W. (P3) Ins. cart. 003 antioraria (P3)	Pumpeneinheit 003 Linkslauf (P3) Conjunto cart. y platos 003 giro i. (P3)	Cart. et plaque ass. 003 rot. g. (P3)	S24.10750	1
C	Cart. and plate ass'y 005 C.W. (P3) Ins. cart. 005 oraria (P3)	Pumpeneinheit 005 Rechtslauf (P3) Conjunto cart. y platos 005 giro d. (P3)	Cart. et plaque ass. 005 rot. d. (P3)	S24.10751	1
C	Cart. and plate ass'y 005 C.C.W. (P3) Ins. cart. 005 antioraria (P3)	Pumpeneinheit 005 Linkslauf (P3) Conjunto cart. y platos 005 giro i. (P3)	Cart. et plaque ass. 005 rot. g. (P3)	S24.10752	1
C	Cart. and plate ass'y 006 C.W. (P3) Ins. cart. 006 oraria (P3)	Pumpeneinheit 006 Rechtslauf (P3) Conjunto cart. y platos 006 giro d. (P3)	Cart. et plaque ass. 006 rot. d. (P3)	S24.10753	1
C	Cart. and plate ass'y 006 C.C.W. (P3) Ins. cart. 006 antioraria (P3)	Pumpeneinheit 006 Linkslauf (P3) Conjunto cart. y platos 006 giro i. (P3)	Cart. et plaque ass. 006 rot. g. (P3)	S24.10754	1
C	Cart. and plate ass'y 008 C.W. (P3) Ins. cart. 008 oraria (P3)	Pumpeneinheit 008 Rechtslauf (P3) Conjunto cart. y platos 008 giro d. (P3)	Cart. et plaque ass. 008 rot. d. (P3)	S24.10755	1

Item Pos. Réf. Pos.	Description <i>Descrizione</i>	Benennung <i>Descripcion</i>	Description	Part N° Teil Nr. Code N° Cod. N° Referencia	Qty Stück Qté Q.tà Cant.
C	Cart. and plate ass'y 008 C.C.W. (P3) Ins. cart. 008 antioraria (P3)	Pumpeneinheit 008 Linkslauf (P3) Conjunto cart. y platos 008 giro i. (P3)	Cart. et plaque ass. 008 rot. g. (P3)	S24.10756	1
C	Cart. and plate ass'y 010 C.W. (P3) Ins. cart. 010 oraria (P3)	Pumpeneinheit 010 Rechtslauf (P3) Conjunto cart. y platos 010 giro d. (P3)	Cart. et plaque ass. 010 rot. d. (P3)	S24.10757	1
C	Cart. and plate ass'y 010 C.C.W. (P3) Ins. cart. 010 antioraria (P3)	Pumpeneinheit 010 Linkslauf (P3) Conjunto cart. y platos 010 giro i. (P3)	Cart. et plaque ass. 010 rot. g. (P3)	S24.10758	1
C	Cart. and plate ass'y 012 C.W. (P3) Ins. cart. 012 oraria (P3)	Pumpeneinheit 012 Rechtslauf (P3) Conjunto cart. y platos 012 giro d. (P3)	Cart. et plaque ass. 012 rot. d. (P3)	S24.26482	1
C	Cart. and plate ass'y 012 C.C.W. (P3) Ins. cart. 012 antioraria (P3)	Pumpeneinheit 012 Linkslauf (P3) Conjunto cart. y platos 012 giro i. (P3)	Cart. et plaque ass. 012 rot. g. (P3)	S24.26483	1
C	Cart. and plate ass'y 014 C.W. (P3) Ins. cart. 014 oraria (P3)	Pumpeneinheit 014 Rechtslauf (P3) Conjunto cart. y platos 014 giro d. (P3)	Cart. et plaque ass. 014 rot. d. (P3)	S24.10759	1
C	Cart. and plate ass'y 014 C.C.W. (P3) Ins. cart. 014 antioraria (P3)	Pumpeneinheit 014 Linkslauf (P3) Conjunto cart. y platos 014 giro i. (P3)	Cart. et plaque ass. 014 rot. g. (P3)	S24.10760	1
C	Cart. and plate ass'y 017 C.W. (P3) Ins. cart. 017 oraria (P3)	Pumpeneinheit 017 Rechtslauf (P3) Conjunto cart. y platos 017 giro d. (P3)	Cart. et plaque ass. 017 rot. d. (P3)	S24.10761	1
C	Cart. and plate ass'y 017 C.C.W. (P3) Ins. cart. 017 antioraria (P3)	Pumpeneinheit 017 Linkslauf (P3) Conjunto cart. y platos 017 giro i. (P3)	Cart. et plaque ass. 017 rot. g. (P3)	S24.10762	1
C	Cart. and plate ass'y 020 C.W. (P3) Ins. cart. 020 oraria (P3)	Pumpeneinheit 020 Rechtslauf (P3) Conjunto cart. y platos 020 giro d. (P3)	Cart. et plaque ass. 020 rot. d. (P3)	S24.31023	1
C	Cart. and plate ass'y 020 C.C.W. (P3) Ins. cart. 020 antioraria (P3)	Pumpeneinheit 020 Linkslauf (P3) Conjunto cart. y platos 020 giro i. (P3)	Cart. et plaque ass. 020 rot. g. (P3)	S24.40032	1
C	Cart. and plate ass'y 022 C.W. (P3) Ins. cart. 022 oraria (P3)	Pumpeneinheit 022 Rechtslauf (P3) Conjunto cart. y platos 022 giro d. (P3)	Cart. et plaque ass. 022 rot. d. (P3)	S24.10763	1
C	Cart. and plate ass'y 022 C.C.W. (P3) Ins. cart. 022 antioraria (P3)	Pumpeneinheit 022 Linkslauf (P3) Conjunto cart. y platos 022 giro i. (P3)	Cart. et plaque ass. 022 rot. g. (P3)	S24.10764	1
C	Cart. and plate ass'y 025 C.W. (P3) Ins. cart. 025 oraria (P3)	Pumpeneinheit 025 Rechtslauf (P3) Conjunto cart. y platos 025 giro d. (P3)	Cart. et plaque ass. 025 rot. d. (P3)	S24.10765	1
C	Cart. and plate ass'y 025 C.C.W. (P3) Ins. cart. 025 antioraria (P3)	Pumpeneinheit 025 Linkslauf (P3) Conjunto cart. y platos 025 giro i. (P3)	Cart. et plaque ass. 025 rot. g. (P3)	S24.10766	1
C	Cart. and plate ass'y 028 C.W. (P3) Ins. cart. 028 oraria (P3)	Pumpeneinheit 028 Rechtslauf (P3) Conjunto cart. y platos 028 giro d. (P3)	Cart. et plaque ass. 028 rot. d. (P3)	S24.25547	1
C	Cart. and plate ass'y 028 C.C.W. (P3) Ins. cart. 028 antioraria (P3)	Pumpeneinheit 028 Linkslauf (P3) Conjunto cart. y platos 028 giro i. (P3)	Cart. et plaque ass. 028 rot. g. (P3)	S24.25546	1
C	Cart. and plate ass'y 031 C.W. (P3) Ins. cart. 031 oraria (P3)	Pumpeneinheit 031 Rechtslauf (P3) Conjunto cart. y platos 031 giro d. (P3)	Cart. et plaque ass. 031 rot. d. (P3)	S24.45771	1
C	Cart. and plate ass'y 031 C.C.W. (P3) Ins. cart. 031 antioraria (P3)	Pumpeneinheit 031 Linkslauf (P3) Conjunto cart. y platos 031 giro i. (P3)	Cart. et plaque ass. 031 rot. g. (P3)	S24.45772	1
D	Seal kit (S1 - 0,7 bar) <i>Serie guarnizioni (S1 - 0,7 bar)</i>	Dichtringsatz (S1 - 0,7 bar) <i>Juego de juntas (S1 - 0,7 bar)</i>	Pochette de joint (S1 - 0,7 bar)	S24.25575	1
D	Seal kit (S4 - 7 bar) <i>Serie guarnizioni (S4 - 7 bar)</i>	Dichtringsatz (S4 - 7 bar) <i>Juego de juntas (S4 - 7 bar)</i>	Pochette de joint (S4 - 7 bar)	S24.25575.4	1
D	Seal kit (S5 - 7 bar) <i>Serie guarnizioni (S5 - 7 bar)</i>	Dichtringsatz (S5 - 7 bar) <i>Juego de juntas (S5 - 7 bar)</i>	Pochette de joint (S5 - 7 bar)	S24.25575.5	1
E	Shaft and bearing ass'y (code 1) <i>Ins. albero (codice 1)</i>	Baugruppe (Welle u. Lager) (Typ 1) <i>Conjunto eje cojinete (codigo 1)</i>	Arbre et roulement ass. (code 1)	S24.25571	1
F	Shaft and bearing ass'y (code 2) <i>Ins. albero (codice 2)</i>	Baugruppe (Welle u. Lager) (Typ 2) <i>Conjunto eje cojinete (codigo 2)</i>	Arbre et roulement ass. (code 2)	S24.25572	1
G	Shaft and bearing ass'y (code 3) <i>Ins. albero (codice 3)</i>	Baugruppe (Welle u. Lager) (Typ 3) <i>Conjunto eje cojinete (codigo 3)</i>	Arbre et roulement ass. (code 3)	S24.25573	1

Model Code

Typenschlüssel

Désignation - type

Model number

Typenbezeichnung :

Numéro du modèle :

T67DCC - **B38** - **028** - **010** - **1** **R** **00** - **A** **1** **M1** - ..

Series - SAE C - 2 bolts
Mounting flange J744

Baureihe - SAE C 2-Loch
Montageflansch, J744

Série - SAE C 2 trous
Bride de montage J744

One letter can be added to specify special parts in series

Optionen

Une lettre peut être ajoutée pour spécifier les pièces spéciales dans la série.

Cam ring P1

(Volumetric displacement) (ml/rev.)

B14 = 44,0
B17 = 55,0
B20 = 66,0
B22 = 70,3

Hubring P1

(Geometrisches Fördervolumen) (cm³/U)

B24 = 81,1
B28 = 90,0
B31 = 99,2
B35 = 113,4

Came P1

(Cylindree théorique) (cm³/tr)

B38 = 120,6
B42 = 137,5
045 = 145,7
050 = 158,0

Cam ring P2 & P3

(Volumetric displacement) (ml/rev.)

003 = 10,8
005 = 17,2
006 = 21,3
008 = 26,4
010 = 34,1

Hubring P2 & P3

(Geometrisches Fördervolumen) (cm³/U)

012 = 37,1
014 = 46,0
017 = 58,3
020 = 63,8

Came P2 & P3

(Cylindree théorique) (cm³/tr)

022 = 70,3
025 = 79,3
028 = 88,8
031 = 100,0

Type of shaft

1 = keyed (non SAE)
2 = keyed (SAE CC)
3 = splined 12/24 (SAE C)
4 = splined 12/24 (SAE CC)

Art der Welle

1 = Paßfederwelle (nicht SAE)
2 = Paßfederwelle (SAE CC)
3 = Vielkeilwelle 12/24 (SAE C)
4 = Vielkeilwelle 12/24 (SAE CC)

Type d'arbre

1 = à clavette (non SAE)
2 = à clavette (SAE CC)
3 = à cannelures 12/24 (SAE C)
4 = à cannelures 12/24 (SAE CC)

Direction of rotation

R = Clockwise
L = Counter-clockwise

Drehrichtung

R = Rechtslauf
L = Linkslauf

Sens de rotation

R = à droite
L = à gauche

Porting combination

00 = standard

Lage der Anschlüsse

00 = standard

Combinaison des orifices

00 = standard

Design letter

Ausführungsbuchstabe

Conception

Seal class

1 = S1 - BUNA N
4 = S4 - EPDM
5 = S5 - VITON

Dichtungsklasse

1 = S1 - BUNA N
4 = S4 - EPDM
5 = S5 - VITON

Classe de joint

1 = S1 - BUNA N
4 = S4 - EPDM
5 = S5 - VITON

Mounting w/connection variables

4 bolts SAE flanges (J518)

	P1 = 1"1/4 - P2 = 1" - S = 4"	
	UNC	Metric
P3 = 1"	00	M0
P3 = 3/4"	01	M1

Gehäuse-Anschlußgröße

SAE-Vierlochflansch (J518)

	P1 = 1"1/4 - P2 = 1" - S = 4"	
	UNC	Metrisches
P3 = 1"	00	M0
P3 = 3/4"	01	M1

Option sur orifices

Bride SAE 4 trous (J518)

	P1 = 1"1/4 - P2 = 1" - S = 4"	
	UNC	Métrique
P3 = 1"	00	M0
P3 = 3/4"	01	M1

Modifications

Modifikationen

Modifications

Designazione

Clave de designación

Sigla :

Serie - SAE C 2 fori
Flangia di montaggio J744

Una lettera può essere aggiunta per specificare parti speciali nella serie

Tipo di cartuccia P1

(Cilindrata) (ml/giro)

B14 = 44,0
B17 = 55,0
B20 = 66,0
B22 = 70,3
B24 = 81,1
B28 = 90,0

Tipo di cartuccia P2 & P3

(Cilindrata) (ml/giro)

003 = 10,8
005 = 17,2
006 = 21,3
008 = 26,4
010 = 34,1
012 = 37,1
014 = 46,0

Tipo di albero

1 = a chiavetta (SAE C)
2 = a chiavetta (SAE CC)
3 = scanalato 12/24 (SAE C)
4 = scanalato 12/24 (SAE CC)

Senso di rotazione

R = Orario
L = Antiorario

Orientamento delle bocche

00 = standard

Disegno

Tipo di guarnizioni

1 = S1 - BUNA N
4 = S4 - EPDM
5 = S5 - VITON

Dimensioni delle bocche

Flangia SAE 4 drenaggio (J518)

	P1 = 1"1/4 - P2 = 1" - S = 4"	
	UNC	Metrica
P3 = 1"	00	M0
P3 = 3/4"	01	M1

Modifiche

Referencia modelo :

Serie - SAE C 2 taladros
Brida de montaje J744

Una letra puede ser añadida para especificar piezas especiales en la serie

Aro volumetrico P1

(Cilindrada) (ml/rev)

B31 = 99,2
B35 = 113,4
B38 = 120,6
B42 = 137,5
045 = 145,7
050 = 158,0

Aro volumetrico P2 & P3

(Cilindrada) (ml/rev)

017 = 58,3
020 = 63,8
022 = 70,3
025 = 79,3
028 = 88,8
031 = 100,0

Tipo de eje

1 = chaveteado (SAE C)
2 = chaveteado (SAE CC)
3 = estriado 12/24 (SAE C)
4 = estriado 12/24 (SAE CC)

Sentido de giro

R = Derecha
L = Izquierda

Posición de bocas

00 = estándar

Letra de diseño

Clase de juntas

1 = S1 - BUNA N
4 = S4 - EPDM
5 = S5 - VITON

Opciones de las bocas

Brida SAE 4 taladros (J518)

	P1 = 1"1/4 - P2 = 1" - S = 4"	
	UNC	Metrico
P3 = 1"	00	M0
P3 = 3/4"	01	M1

Modificaciones

T67DCC - B38 - 028 - 010 - 1 R 00 - A 1 M1 - ..