



Vane pumps Service information

vane-type double pump / Flügelzellen-Doppelpumpe

pompe double à palettes / pompa doppia a palette

tipo bomba de paletas doble

T67EC

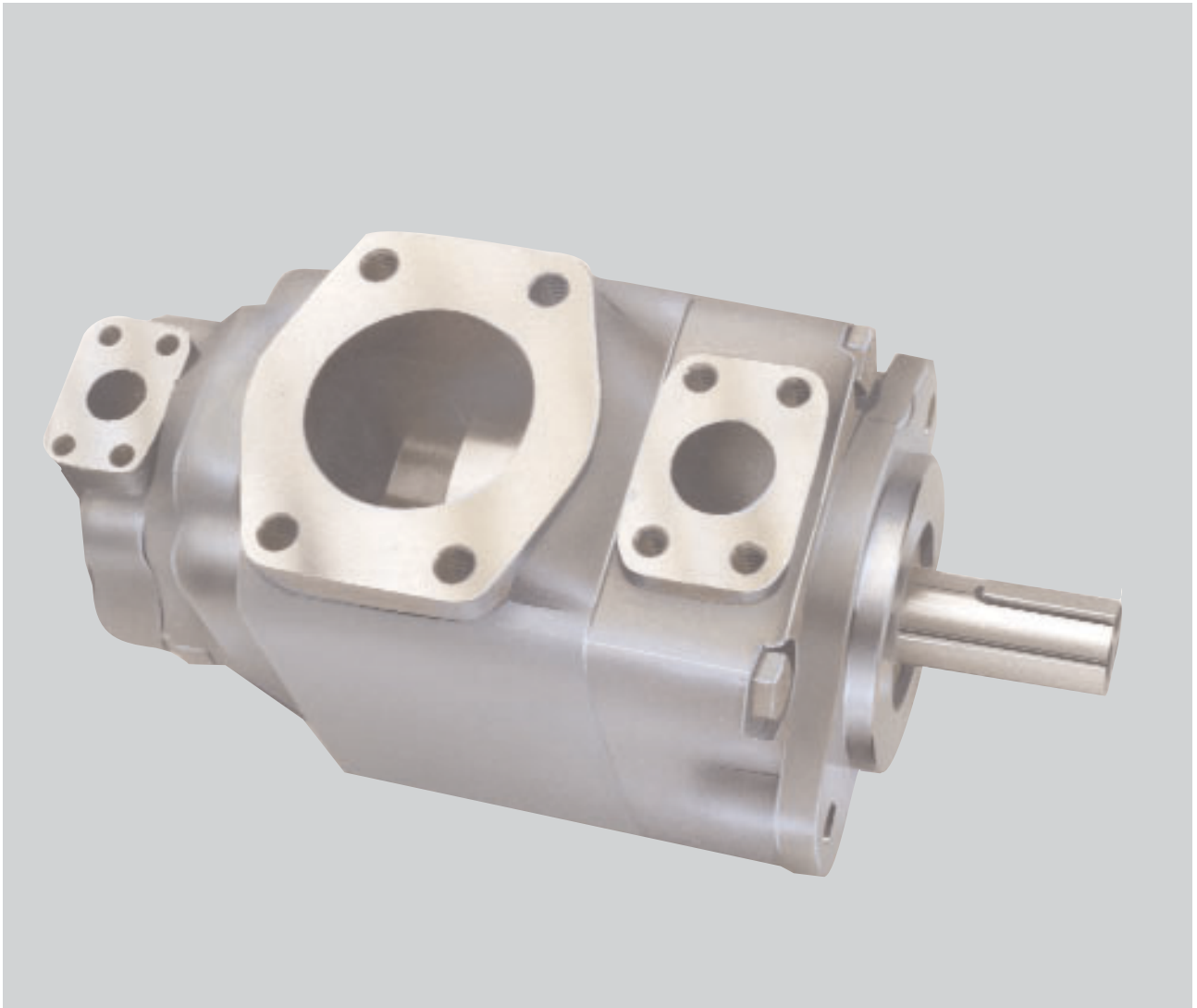

Recommended repair kits and assy's are bold printed
 Empfohlene Austausch - Baugruppen sind fett gedruckt
 Les pochettes de rechange recommandées sont imprimées en caractères gras
 I kit di ricambio consigliati sono indicati in grassetto
 Los juegos de reparacion recomendados y los conjuntos, estan en negrita

	Item - Pos. - Réf. - Pos.	
	22	35
Mounting torque		
Anziehdrehmoment	187 Nm	68 Nm
Couple de serrage	138 ft.lbs	50 ft.lbs
Coppia di serraggio		
Par de apriete		

T67EC

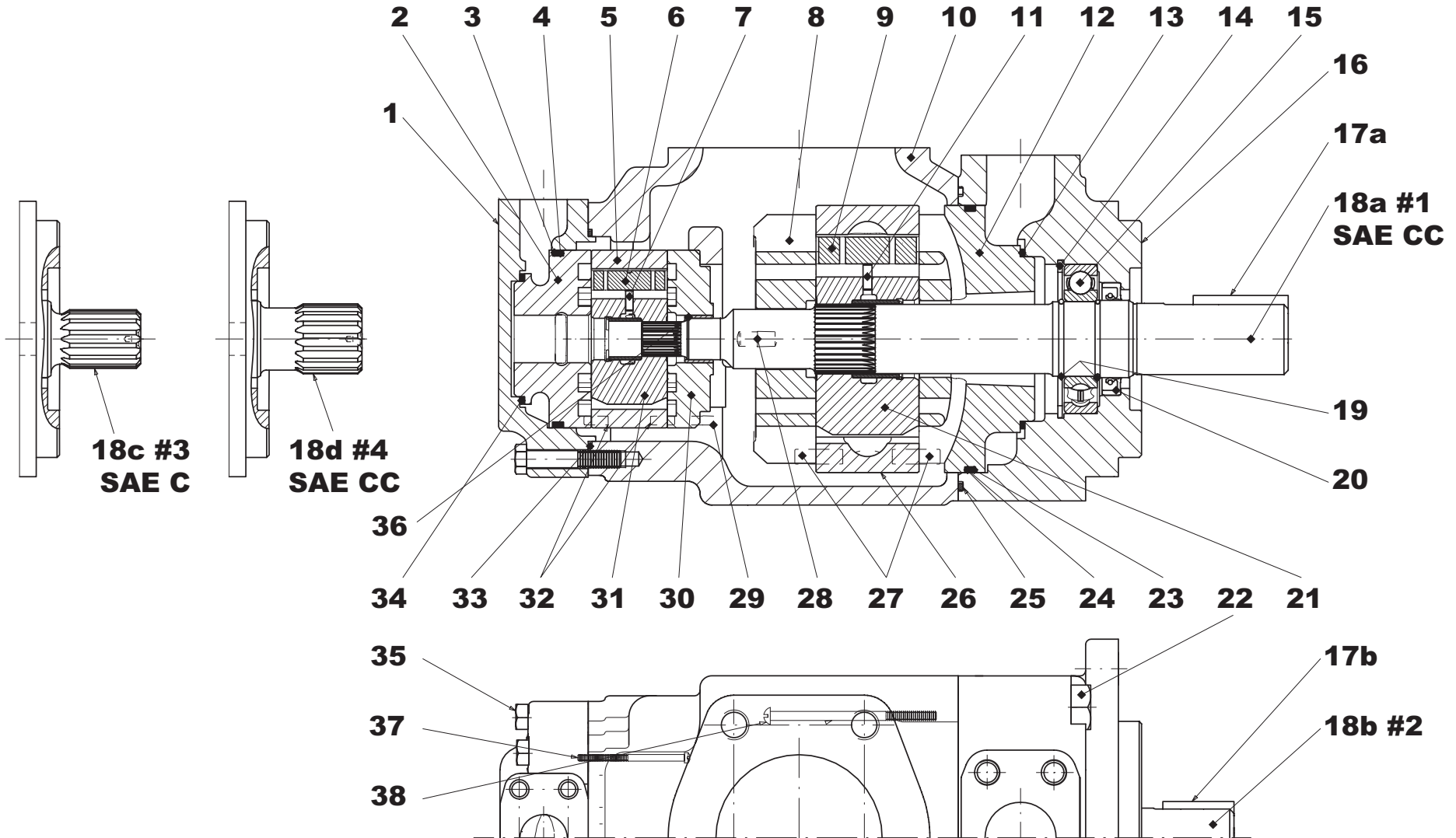

Item Pos. Réf. Pos.	Description Descrizione	Benennung Descripcion	Description		Part N° Teil Nr. Code N° Cod. N° Referencia	Qty Stück Qté Q.tà Cant.	
1	End cap 1" (metric) <i>Coperchio 1" (metrica)</i>	Deckel 1" (Metrisch) <i>Tapa 1" (metrico)</i>	Chapeau 1" (métrique)		034.71327	1	
	End cap 1" (UNC) <i>Coperchio 1" (UNC)</i>	Deckel 1" (UNC) <i>Tapa 1" (UNC)</i>	Chapeau 1" (UNC)		034.48579	1	
	End cap 3/4" (metric) <i>Coperchio 3/4" (metrica)</i>	Deckel 3/4" (Metrisch) <i>Tapa 3/4" (metrico)</i>	Chapeau 3/4" (métrique)		034.66765	1	
	End cap 3/4" (UNC) <i>Coperchio 3/4" (UNC)</i>	Deckel 3/4" (UNC) <i>Tapa 3/4" (UNC)</i>	Chapeau 3/4" (UNC)		034.66523	1	
	2	Port plate-pressure C.C.W. <i>Piatto distributore anter. antioraria</i>	Steuerplatte Linkslauf <i>Plato distribuidor-presión giro I</i>	Plaque pression rotation gauche	B	034.59773	1
Port plate-pressure C.W. <i>Piatto distributore anter. oraria</i>		Steuerplatte Rechtslauf <i>Plato distribuidor-presión giro D</i>	Plaque pression rotation droite	B	034.59772	1	
3	Sq. section seal <i>Guarnizione</i>	Dichtring <i>Junta seccion cuadrada</i>	Joint section carrée	BC	691.10238	1	
4	Back-up ring <i>Anello anti-estrusione</i>	Stützring <i>Anillo</i>	Bague anti-extrusion	BC	618.00010.3	1	
5	Cam ring 003 <i>Anello camma 003</i>	Hubring 003 <i>Aro volumetrico 003</i>	Came 003	B	034.59050	1	
	Cam ring 005 <i>Anello camma 005</i>	Hubring 005 <i>Aro volumetrico 005</i>	Came 005	B	034.59051	1	
	Cam ring 006 <i>Anello camma 006</i>	Hubring 006 <i>Aro volumetrico 006</i>	Came 006	B	034.59052	1	
	Cam ring 008 <i>Anello camma 008</i>	Hubring 008 <i>Aro volumetrico 008</i>	Came 008	B	034.59053	1	
	Cam ring 010 <i>Anello camma 010</i>	Hubring 010 <i>Aro volumetrico 010</i>	Came 010	B	034.59054	1	
	Cam ring 012 <i>Anello camma 012</i>	Hubring 012 <i>Aro volumetrico 012</i>	Came 012	B	034.66595	1	
	Cam ring 014 <i>Anello camma 014</i>	Hubring 014 <i>Aro volumetrico 014</i>	Came 014	B	034.59206	1	
	Cam ring 017 <i>Anello camma 017</i>	Hubring 017 <i>Aro volumetrico 017</i>	Came 017	B	034.59207	1	
	Cam ring 020 <i>Anello camma 020</i>	Hubring 020 <i>Aro volumetrico 020</i>	Came 020	B	034.66607	1	
	Cam ring 022 <i>Anello camma 022</i>	Hubring 022 <i>Aro volumetrico 022</i>	Came 022	B	034.59208	1	
	Cam ring 025 <i>Anello camma 025</i>	Hubring 025 <i>Aro volumetrico 025</i>	Came 025	B	034.59209	1	
	Cam ring 028 <i>Anello camma 028</i>	Hubring 028 <i>Aro volumetrico 028</i>	Came 028	B	034.59245	1	
	Cam ring 031 <i>Anello camma 031</i>	Hubring 031 <i>Aro volumetrico 031</i>	Came 031	B	034.66843	1	
	6	Vane <i>Paletta</i>	Flügel <i>Paleta</i>	Palette	B	034.59099	10
	7	Pin-vane holdout <i>Pistoncino di sostentamento</i>	Stößel <i>Espiga empuje paleta</i>	Poussoir de palette	B	034.59098	10
8	Port plate-rear C.C.W. <i>Piatto distributore post. Antioraria</i>	Steuerplatte Linkslauf <i>Plato distribuidor trasero giro I</i>	Plaque arr. rotation gauche	AK	034.67435	1	
	Port plate-rear C.W. <i>Piatto distributore post. Oraria</i>	Steuerplatte Rechtslauf <i>Plato distribuidor trasero giro D</i>	Plaque arr. rotation droite	AL	034.67407	1	

Item Pos. Réf. Pos.	Description Descrizione	Benennung Descripcion	Description		Part N° Teil Nr. Code N° Cod. N° Referencia	Qty Stück Qté Q.tà Cant.
9	Vane <i>Paletta</i>	Flügel <i>Paleta</i>	Palette	A	034.59162	12
10	Housing (standard) (metric) <i>Corpo (standard) (metrico)</i>	Gehäuse (Standard) (Metrisch) <i>Cuerpo (estándar) (metrica)</i>	Carter (standard) (métrique)		034.66734	1
	Housing (standard) (UNC) <i>Corpo (standard) (UNC)</i>	Gehäuse (Standard) (UNC) <i>Cuerpo (estándar) (UNC)</i>	Carter (standard) (UNC)		034.70263	1
11	Pin-vane holdout <i>Pistoncino di sostentamento</i>	Stössel <i>Espiga empuje paleta</i>	Poussoir de palette	A	034.59161	12
12	Port plate-pressure C.C.W. <i>Piatto distributore anter. antioraria</i>	Steuerplatte Linkslauf <i>Plato distribuidor-presión giro I</i>	Plaque pression rotation gauche	A	034.67434	1
	Port plate-pressure C.W. <i>Piatto distributore anter. oraria</i>	Steuerplatte Rechtslauf <i>Plato distribuidor-presión giro D</i>	Plaque pression rotation droite	A	034.67408	1
13	Sq. section seal <i>Guarnizione</i>	Dichtring <i>Junta seccion cuadrada</i>	Joint section carrée	AC	691.10237	1
14	Retaining ring <i>Anello elastico</i>	Sicherungsring <i>Anillo de retención</i>	Circlips		356.30315	1
15	Ball bearing <i>Cuscinetto a sfera</i>	Kugellager <i>Cojinete de bolas</i>	Roulement à billes	DE FG	230.03208	1
16	Mounting cap (metric) <i>Coperchio (metrica)</i>	Deckel (Metrisch) <i>Tapa de montaje 1" (metrico)</i>	Chapeau de montage (métrique)		034.66735	1
	Mounting cap (UNC) <i>Coperchio (UNC)</i>	Deckel (UNC) <i>Tapa de montaje (UNC)</i>	Chapeau de montage (UNC)		034.70265	1
	Mounting cap (ISO) <i>Coperchio (ISO)</i>	Deckel (ISO) <i>Tapa de montaje (ISO)</i>	Chapeau de montage (ISO)		034.67646	1
17a	Key (code 1) <i>Chiavetta (codice 1)</i>	Paßfeder (Typ 1) <i>Chaveta (codigo 1)</i>	Clavette (code 1)	D	034.70330	1
17b	Key (code 2) <i>Chiavetta (codice 2)</i>	Paßfeder (Typ 2) <i>Chaveta (codigo 2)</i>	Clavette (code 2)	E	034.49676	1
18a	Shaft (keyed) (code1) (SAE CC) <i>Albero a chiavetta (codice 1) (SAE CC)</i>	Welle für Paßfeder (Typ 1) (SAE CC) <i>Eje chaveteado (codigo 1) (SAE CC)</i>	Arbre à clavette (code 1) (SAE CC)	D	034.71408	1
18b	Shaft (keyed) (code 2) <i>Albero a chiavetta (codice 2)</i>	Welle für Paßfeder (Typ 2) <i>Eje chaveteado (codigo 2)</i>	Arbre à clavette (code 2)	E	034.66891	1
18c	Shaft (splined) (code 3) (SAE C) <i>Albero a scanalato (codice 3) (SAE C)</i>	Vielkeilwelle (Typ 3) (SAE C) <i>Eje estriado (codigo 3) (SAE C)</i>	Arbre à cannelures (code 3) (SAE C)	F	034.71315	1
18d	Shaft (splined) (code 4) (SAE CC) <i>Albero a scanalato (codice 4) (SAE CC)</i>	Vielkeilwelle (Typ 4) (SAE CC) <i>Eje estriado (codigo 4) (SAE CC)</i>	Arbre à cannelures (code 4) (SAE CC)	G	034.71409	1
19	Round section ring <i>Anello elastico</i>	Sicherungsring <i>Anillo tórico</i>	Anneau	DE FG	034.70866	2
20	Shaft seal (S1 - 0,7 bar) <i>Paraolio (S1 - 0,7 bar)</i>	Simmerring (S1 - 0,7 bar) <i>Reten eje (S1 - 0,7 bar)</i>	Joint d'arbre (S1 - 0,7 bar)	C	620.82064	1
	Shaft seal (S4 - S5 - 7 bar) <i>Paraolio (S4 - S5 - 7 bar)</i>	Simmerring (S4 - S5 - 7 bar) <i>Reten eje (S4 - S5 - 7 bar)</i>	Joint d'arbre (S4 - S5 - 7 bar)	C	620.82072	1
21	Rotor ass'y <i>Insieme rotore</i>	Rotor <i>Conjunto rotor</i>	Rotor ass.	A	S24.10185	1
22	Screw <i>Vite</i>	Schraube <i>Tornille</i>	Vis		306.40216	4
23	Sq. section seal <i>Guarnizione</i>	Dichtring <i>Junta seccion cuadrada</i>	Joint section carrée	AC	691.10253	1
24	Back-up ring <i>Anello anti-estrusione</i>	Stützring <i>Anillo</i>	Bague anti-extrusion	AC	618.00012.3	1

Item Pos. Réf. Pos. Pos.	Description Descrizione	Benennung Descripcion	Description		Part N° Teil Nr. Code N° Cod. N° Referencia	Qty Stück Qté Q.tà Cant.	
25	Sq. section seal <i>Guarnizione</i>	Dichtring <i>Junta seccion cuadrada</i>	Joint section carrée	AC	691.10259	1	
26	Cam ring 042 <i>Anello camma 042</i>	Hubring 042 <i>Aro volumetrico 042</i>	Came 042	A	034.67503	1	
	Cam ring 045 <i>Anello camma 045</i>	Hubring 045 <i>Aro volumetrico 045</i>	Came 045	A	034.67504	1	
	Cam ring 050 <i>Anello camma 050</i>	Hubring 050 <i>Aro volumetrico 050</i>	Came 050	A	034.67505	1	
	Cam ring 052 <i>Anello camma 052</i>	Hubring 052 <i>Aro volumetrico 052</i>	Came 052	A	034.67506	1	
	Cam ring 054 <i>Anello camma 054</i>	Hubring 054 <i>Aro volumetrico 054</i>	Came 054	A	034.67619	1	
	Cam ring 057 <i>Anello camma 057</i>	Hubring 057 <i>Aro volumetrico 057</i>	Came 057	A	034.67507	1	
	Cam ring 062 <i>Anello camma 062</i>	Hubring 062 <i>Aro volumetrico 062</i>	Came 062	A	034.67508	1	
	Cam ring 066 <i>Anello camma 066</i>	Hubring 066 <i>Aro volumetrico 066</i>	Came 066	A	034.67509	1	
	Cam ring 072 <i>Anello camma 072</i>	Hubring 072 <i>Aro volumetrico 072</i>	Came 072	A	034.67447	1	
	Cam ring 085 <i>Anello camma 085</i>	Hubring 085 <i>Aro volumetrico 085</i>	Came 085	A	034.67455	1	
	27	Dowel pin <i>Spina</i>	Zentrierstift <i>Pasador</i>	Goupille	A	324.22016	2
	28	Dowel pin <i>Spina</i>	Zentrierstift <i>Pasador</i>	Goupille	AKL	323.82014	1
	29	Dowel pin <i>Spina</i>	Zentrierstift <i>Pasador</i>	Goupille	BHJ	323.82010	1
	30	Port plate-rear C.C.W. <i>Piatto distributore post. Antioraria</i>	Steuerplatte Linkslauf <i>Plato distribuidor trasero giro I</i>	Plaque arr. rotation gauche	BJ	034.59776	1
Port plate-rear C.W. <i>Piatto distributore post. Oraria</i>		Steuerplatte Rechtslauf <i>Plato distribuidor trasero giro D</i>	Plaque arr. rotation droite	BH	034.59777	1	
31	Rotor ass'y <i>Insieme rotore</i>	Rotor <i>Conjunto rotor</i>	Rotor ass.	B	S24.10116	1	
32	Dowel pin <i>Spina</i>	Zentrierstift <i>Pasador</i>	Goupille	B	324.21208	2	
33	Sq. section seal <i>Guarnizione</i>	Dichtring <i>Junta seccion cuadrada</i>	Joint section carrée	BC	671.10156	1	
34	Sq. section seal <i>Guarnizione</i>	Dichtring <i>Junta seccion cuadrada</i>	Joint section carrée	BC	691.10229	1	
35	Screw <i>Vite</i>	Schraube <i>Tornille</i>	Vis		306.40111	7	
36	Bush <i>Bussola</i>	Buchse <i>Cojinete de fricción</i>	Bague	BHJ	034.70868	1	
37	Screw <i>Vite</i>	Schraube <i>Tornille</i>	Vis	B	317.06266	2	
38	Screw <i>Vite</i>	Schraube <i>Tornille</i>	Vis	A	310.10340	2	

Item Pos. Réf. Pos.	Description Descrizione	Benennung Descripcion	Description	Part N° Teil Nr. Code N° Cod. N° Referencia	Qty Stúck Qté Q.tà Cant.
	REPAIR KIT KIT DI RICAMBIO	AUSTAUSCH-BAUGRUPPEN CUNJUNTO REPARACION	POCHETTES RECHANGES		
A	Cart. and plate ass'y 042 C.W. (P1) Ins. cart. 042 oraria (P1)	Pumpeneinheit 042 Rechtslauf (P1) Conjunto cart. y platos 042 giro d. (P1)	Cart. et plaque ass. 042 rot. d. (P1)	S24.77675	1
A	Cart. and plate ass'y 042 C.C.W. (P1) Ins. cart. 042 antioraria (P1)	Pumpeneinheit 042 Linkslauf (P1) Conjunto cart. y platos 042 giro i. (P1)	Cart. et plaque ass. 042 rot. g. (P1)	S24.77676	1
A	Cart. and plate ass'y 045 C.W. (P1) Ins. cart. 045 oraria (P1)	Pumpeneinheit 045 Rechtslauf (P1) Conjunto cart. y platos 045 giro d. (P1)	Cart. et plaque ass. 045 rot. d. (P1)	S24.77677	1
A	Cart. and plate ass'y 045 C.C.W. (P1) Ins. cart. 045 antioraria (P1)	Pumpeneinheit 045 Linkslauf (P1) Conjunto cart. y platos 045 giro i. (P1)	Cart. et plaque ass. 045 rot. g. (P1)	S24.77678	1
A	Cart. and plate ass'y 050 C.W. (P1) Ins. cart. 050 oraria (P1)	Pumpeneinheit 050 Rechtslauf (P1) Conjunto cart. y platos 050 giro d. (P1)	Cart. et plaque ass. 050 rot. d. (P1)	S24.77679	1
A	Cart. and plate ass'y 050 C.C.W. (P1) Ins. cart. 050 antioraria (P1)	Pumpeneinheit 050 Linkslauf (P1) Conjunto cart. y platos 050 giro i. (P1)	Cart. et plaque ass. 050 rot. g. (P1)	S24.77680	1
A	Cart. and plate ass'y 052 C.W. (P1) Ins. cart. 052 oraria (P1)	Pumpeneinheit 052 Rechtslauf (P1) Conjunto cart. y platos 052 giro d. (P1)	Cart. et plaque ass. 052 rot. d. (P1)	S24.77681	1
A	Cart. and plate ass'y 052 C.C.W. (P1) Ins. cart. 052 antioraria (P1)	Pumpeneinheit 052 Linkslauf (P1) Conjunto cart. y platos 052 giro i. (P1)	Cart. et plaque ass. 052 rot. g. (P1)	S24.77682	1
A	Cart. and plate ass'y 054 C.W. (P1) Ins. cart. 054 oraria (P1)	Pumpeneinheit 054 Rechtslauf (P1) Conjunto cart. y platos 054 giro d. (P1)	Cart. et plaque ass. 054 rot. d. (P1)	S24.77683	1
A	Cart. and plate ass'y 054 C.C.W. (P1) Ins. cart. 054 antioraria (P1)	Pumpeneinheit 054 Linkslauf (P1) Conjunto cart. y platos 054 giro i. (P1)	Cart. et plaque ass. 054 rot. g. (P1)	S24.77684	1
A	Cart. and plate ass'y 057 C.W. (P1) Ins. cart. 057 oraria (P1)	Pumpeneinheit 057 Rechtslauf (P1) Conjunto cart. y platos 057 giro d. (P1)	Cart. et plaque ass. 057 rot. d. (P1)	S24.77685	1
A	Cart. and plate ass'y 057 C.C.W. (P1) Ins. cart. 057 antioraria (P1)	Pumpeneinheit 057 Linkslauf (P1) Conjunto cart. y platos 057 giro i. (P1)	Cart. et plaque ass. 057 rot. g. (P1)	S24.77686	1
A	Cart. and plate ass'y 062 C.W. (P1) Ins. cart. 062 oraria (P1)	Pumpeneinheit 062 Rechtslauf (P1) Conjunto cart. y platos 062 giro d. (P1)	Cart. et plaque ass. 062 rot. d. (P1)	S24.77687	1
A	Cart. and plate ass'y 062 C.C.W. (P1) Ins. cart. 062 antioraria (P1)	Pumpeneinheit 062 Linkslauf (P1) Conjunto cart. y platos 062 giro i. (P1)	Cart. et plaque ass. 062 rot. g. (P1)	S24.77688	1
A	Cart. and plate ass'y 066 C.W. (P1) Ins. cart. 066 oraria (P1)	Pumpeneinheit 066 Rechtslauf (P1) Conjunto cart. y platos 066 giro d. (P1)	Cart. et plaque ass. 066 rot. d. (P1)	S24.77689	1
A	Cart. and plate ass'y 066 C.C.W. (P1) Ins. cart. 066 antioraria (P1)	Pumpeneinheit 066 Linkslauf (P1) Conjunto cart. y platos 066 giro i. (P1)	Cart. et plaque ass. 066 rot. g. (P1)	S24.77690	1
A	Cart. and plate ass'y 072 C.W. (P1) Ins. cart. 072 oraria (P1)	Pumpeneinheit 072 Rechtslauf (P1) Conjunto cart. y platos 072 giro d. (P1)	Cart. et plaque ass. 072 rot. d. (P1)	S24.77691	1
A	Cart. and plate ass'y 072 C.C.W. (P1) Ins. cart. 072 antioraria (P1)	Pumpeneinheit 072 Linkslauf (P1) Conjunto cart. y platos 072 giro i. (P1)	Cart. et plaque ass. 072 rot. g. (P1)	S24.77692	1
A	Cart. and plate ass'y 085 C.W. (P1) Ins. cart. 085 oraria (P1)	Pumpeneinheit 085 Rechtslauf (P1) Conjunto cart. y platos 085 giro d. (P1)	Cart. et plaque ass. 085 rot. d. (P1)	S24.77693	1
A	Cart. and plate ass'y 085 C.C.W. (P1) Ins. cart. 085 antioraria (P1)	Pumpeneinheit 085 Linkslauf (P1) Conjunto cart. y platos 085 giro i. (P1)	Cart. et plaque ass. 085 rot. g. (P1)	S24.77694	1
B	Cart. and plate ass'y 003 C.W. (P2) Ins. cart. 003 oraria (P2)	Pumpeneinheit 003 Rechtslauf (P2) Conjunto cart. y platos 003 giro d. (P2)	Cart. et plaque ass. 003 rot. d. (P2)	S24.10767	1
B	Cart. and plate ass'y 003 C.C.W. (P2) Ins. cart. 003 antioraria (P2)	Pumpeneinheit 003 Linkslauf (P2) Conjunto cart. y platos 003 giro i. (P2)	Cart. et plaque ass. 003 rot. g. (P2)	S24.10768	1
B	Cart. and plate ass'y 005 C.W. (P2) Ins. cart. 005 oraria (P2)	Pumpeneinheit 005 Rechtslauf (P2) Conjunto cart. y platos 005 giro d. (P2)	Cart. et plaque ass. 005 rot. d. (P2)	S24.10769	1
B	Cart. and plate ass'y 005 C.C.W. (P2) Ins. cart. 005 antioraria (P2)	Pumpeneinheit 005 Linkslauf (P2) Conjunto cart. y platos 005 giro i. (P2)	Cart. et plaque ass. 005 rot. g. (P2)	S24.10770	1

Item Pos. Réf. Pos.	Description <i>Descrizione</i>	Benennung <i>Descripcion</i>	Description	Part N° Teil Nr. Code N° Cod. N° Referencia	Qty Stück Qté Q.tà Cant.
B	Cart. and plate ass'y 006 C.W. (P2) Ins. cart. 006 oraria (P2)	Pumpeneinheit 006 Rechtslauf (P2) Conjunto cart. y platos 006 giro d. (P2)	Cart. et plaque ass. 006 rot. d. (P2)	S24.10771	1
B	Cart. and plate ass'y 006 C.C.W. (P2) Ins. cart. 006 antioraria (P2)	Pumpeneinheit 006 Linkslauf (P2) Conjunto cart. y platos 006 giro i. (P2)	Cart. et plaque ass. 006 rot. g. (P2)	S24.10772	1
B	Cart. and plate ass'y 008 C.W. (P2) Ins. cart. 008 oraria (P2)	Pumpeneinheit 008 Rechtslauf (P2) Conjunto cart. y platos 008 giro d. (P2)	Cart. et plaque ass. 008 rot. d. (P2)	S24.10773	1
B	Cart. and plate ass'y 008 C.C.W. (P2) Ins. cart. 008 antioraria (P2)	Pumpeneinheit 008 Linkslauf (P2) Conjunto cart. y platos 008 giro i. (P2)	Cart. et plaque ass. 008 rot. g. (P2)	S24.10774	1
B	Cart. and plate ass'y 010 C.W. (P2) Ins. cart. 010 oraria (P2)	Pumpeneinheit 010 Rechtslauf (P2) Conjunto cart. y platos 010 giro d. (P2)	Cart. et plaque ass. 010 rot. d. (P2)	S24.10775	1
B	Cart. and plate ass'y 010 C.C.W. (P2) Ins. cart. 010 antioraria (P2)	Pumpeneinheit 010 Linkslauf (P2) Conjunto cart. y platos 010 giro i. (P2)	Cart. et plaque ass. 010 rot. g. (P2)	S24.10776	1
B	Cart. and plate ass'y 012 C.W. (P2) Ins. cart. 012 oraria (P2)	Pumpeneinheit 012 Rechtslauf (P2) Conjunto cart. y platos 012 giro d. (P2)	Cart. et plaque ass. 012 rot. d. (P2)	S24.26480	1
B	Cart. and plate ass'y 012 C.C.W. (P2) Ins. cart. 012 antioraria (P2)	Pumpeneinheit 012 Linkslauf (P2) Conjunto cart. y platos 012 giro i. (P2)	Cart. et plaque ass. 012 rot. g. (P2)	S24.26481	1
B	Cart. and plate ass'y 014 C.W. (P2) Ins. cart. 014 oraria (P2)	Pumpeneinheit 014 Rechtslauf (P2) Conjunto cart. y platos 014 giro d. (P2)	Cart. et plaque ass. 014 rot. d. (P2)	S24.10777	1
B	Cart. and plate ass'y 014 C.C.W. (P2) Ins. cart. 014 antioraria (P2)	Pumpeneinheit 014 Linkslauf (P2) Conjunto cart. y platos 014 giro i. (P2)	Cart. et plaque ass. 014 rot. g. (P2)	S24.10778	1
B	Cart. and plate ass'y 017 C.W. (P2) Ins. cart. 017 oraria (P2)	Pumpeneinheit 017 Rechtslauf (P2) Conjunto cart. y platos 017 giro d. (P2)	Cart. et plaque ass. 017 rot. d. (P2)	S24.10779	1
B	Cart. and plate ass'y 017 C.C.W. (P2) Ins. cart. 017 antioraria (P2)	Pumpeneinheit 017 Linkslauf (P2) Conjunto cart. y platos 017 giro i. (P2)	Cart. et plaque ass. 017 rot. g. (P2)	S24.10780	1
B	Cart. and plate ass'y 020 C.W. (P2) Ins. cart. 020 oraria (P2)	Pumpeneinheit 020 Rechtslauf (P2) Conjunto cart. y platos 020 giro d. (P2)	Cart. et plaque ass. 020 rot. d. (P2)	S24.40234	1
B	Cart. and plate ass'y 020 C.C.W. (P2) Ins. cart. 020 antioraria (P2)	Pumpeneinheit 020 Linkslauf (P2) Conjunto cart. y platos 020 giro i. (P2)	Cart. et plaque ass. 020 rot. g. (P2)	S24.40235	1
B	Cart. and plate ass'y 022 C.W. (P2) Ins. cart. 022 oraria (P2)	Pumpeneinheit 022 Rechtslauf (P2) Conjunto cart. y platos 022 giro d. (P2)	Cart. et plaque ass. 022 rot. d. (P2)	S24.10781	1
B	Cart. and plate ass'y 022 C.C.W. (P2) Ins. cart. 022 antioraria (P2)	Pumpeneinheit 022 Linkslauf (P2) Conjunto cart. y platos 022 giro i. (P2)	Cart. et plaque ass. 022 rot. g. (P2)	S24.10782	1
B	Cart. and plate ass'y 025 C.W. (P2) Ins. cart. 025 oraria (P2)	Pumpeneinheit 025 Rechtslauf (P2) Conjunto cart. y platos 025 giro d. (P2)	Cart. et plaque ass. 025 rot. d. (P2)	S24.10783	1
B	Cart. and plate ass'y 025 C.C.W. (P2) Ins. cart. 025 antioraria (P2)	Pumpeneinheit 025 Linkslauf (P2) Conjunto cart. y platos 025 giro i. (P2)	Cart. et plaque ass. 025 rot. g. (P2)	S24.10784	1
B	Cart. and plate ass'y 028 C.W. (P2) Ins. cart. 028 oraria (P2)	Pumpeneinheit 028 Rechtslauf (P2) Conjunto cart. y platos 028 giro d. (P2)	Cart. et plaque ass. 028 rot. d. (P2)	S14.97722	1
B	Cart. and plate ass'y 028 C.C.W. (P2) Ins. cart. 028 antioraria (P2)	Pumpeneinheit 028 Linkslauf (P2) Conjunto cart. y platos 028 giro i. (P2)	Cart. et plaque ass. 028 rot. g. (P2)	S24.25791	1
B	Cart. and plate ass'y 031 C.W. (P2) Ins. cart. 031 oraria (P2)	Pumpeneinheit 031 Rechtslauf (P2) Conjunto cart. y platos 031 giro d. (P2)	Cart. et plaque ass. 031 rot. d. (P2)	S24.45789	1
B	Cart. and plate ass'y 031 C.C.W. (P2) Ins. cart. 031 antioraria (P2)	Pumpeneinheit 031 Linkslauf (P2) Conjunto cart. y platos 031 giro i. (P2)	Cart. et plaque ass. 031 rot. g. (P2)	S24.45790	1
C	Seal kit (S1 - 0,7 bar) <i>Serie guarnizioni (S1 - 0,7 bar)</i>	Dichtringsatz (S1 - 0,7 bar) <i>Juego de juntas (S1 - 0,7 bar)</i>	Pochette de joint (S1 - 0,7 bar)	S24.10242	1
C	Seal kit (S4 - 7 bar) <i>Serie guarnizioni (S4 - 7 bar)</i>	Dichtringsatz (S4 - 7 bar) <i>Juego de juntas (S4 - 7 bar)</i>	Pochette de joint (S4 - 7 bar)	S24.10242.4	1
C	Seal kit (S5 - 7 bar) <i>Serie guarnizioni (S5 - 7 bar)</i>	Dichtringsatz (S5 - 7 bar) <i>Juego de juntas (S5 - 7 bar)</i>	Pochette de joint (S5 - 7 bar)	S24.10242.5	1

Item Pos. Réf. Pos. Pos.	Description <i>Descrizione</i>	Benennung <i>Descripcion</i>	Description	Part N° Teil Nr. Code N° Cod. N° Referencia	Qty Stück Qté Q.tà Cant.
D	Shaft and bearing ass'y (code 1) <i>Ins. albero (codice 1)</i>	Baugruppe (Welle u. Lager) (Typ 1) <i>Conjunto eje cojinete (codigo 1)</i>	Arbre et roulement ass. (code 1)	S14.28178	1
E	Shaft and bearing ass'y (code 2) <i>Ins. albero (codice 2)</i>	Baugruppe (Welle u. Lager) (Typ 2) <i>Conjunto eje cojinete (codigo 2)</i>	Arbre et roulement ass. (code 2)	S24.49213	1
F	Shaft and bearing ass'y (code 3) <i>Ins. albero (codice 3)</i>	Baugruppe (Welle u. Lager) (Typ 3) <i>Conjunto eje cojinete (codigo 3)</i>	Arbre et roulement ass. (code 3)	S14.28176	1
G	Shaft and bearing ass'y (code 4) <i>Ins. albero (codice 4)</i>	Baugruppe (Welle u. Lager) (Typ 4) <i>Conjunto eje cojinete (codigo 4)</i>	Arbre et roulement ass. (code 4)	S14.28177	1
H	Port plate rear ass'y C.C.W. <i>Ins. piatto distributore post. antioraria</i>	Steuerplatte Linkslauf <i>Conj. plato dist. trasero giro I</i>	Plaque arrière ass. rot. gauche	S24.10810	1
J	Port plate rear ass'y C.W. <i>Ins. piatto distributore post. oraria</i>	Steuerplatte Rechtslauf <i>Conj. plato dist. trasero giro D</i>	Plaque arrière ass. rot. droite	S24.10809	1
K	Port plate rear ass'y C.C.W. <i>Ins. piatto distributore post. antioraria</i>	Steuerplatte Linkslauf <i>Conj. plato dist. trasero giro I</i>	Plaque arrière ass. rot. gauche	S24.76213	1
L	Port plate rear ass'y C.W. <i>Ins. piatto distributore post. oraria</i>	Steuerplatte Rechtslauf <i>Conj. plato dist. trasero giro D</i>	Plaque arrière ass. rot. droite	S24.73820	1

Model Code

Typenschlüssel

Désignation - type

Model number :

Typenbezeichnung :

Número du modèle :

T67EC . - 085 - 020 - 1 R 00 - A 1 00 - ..

Series T67EC - SAE C - 2 bolts
Mounting flange J744

Baureihe T67EC - SAE C - 2-Loch
Montageflansch J744

Série T67EC - SAE C - 2 trous
Bride de montage J744

One letter can be added to specify special parts in series

Optionen

Une lettre peut être ajoutée pour spécifier les pièces spéciales dans la série.

Cam ring for P1

(Volumetric displacement) (ml/rev.)

042 = 132,3
045 = 142,4
050 = 158,5
052 = 164,8

Hubring P1

(Geometrisches Fördervolumen) (cm³/U)

054 = 171,0
057 = 183,3
062 = 196,7

Came pour P1

(Cylindree théorique) (cm³/tr)

066 = 213,3
072 = 227,1
085 = 268,7

Cam ring for P2

(Volumetric displacement) (ml/rev.)

003 = 10,8
005 = 17,2
006 = 21,3
008 = 26,4
010 = 34,1

Hubring P2

(Geometrisches Fördervolumen) (cm³/U)

012 = 37,1
014 = 46,0
017 = 58,3
020 = 63,8

Came pour P2

(Cylindree théorique) (cm³/tr)

022 = 70,3
025 = 79,3
028 = 88,8
031 = 100,0

Type of shaft

1 = keyed (SAE CC)
2 = keyed (no SAE)
3 = splined (SAE C)
4 = splined (SAE CC)

Art der Welle

1 = Paßfederwelle (SAE CC)
2 = Paßfederwelle (no SAE)
3 = Vielkeilwelle (SAE C)
4 = Vielkeilwelle (SAE CC)

Type d'arbre

1 = à clavette (SAE CC)
2 = à clavette (no SAE)
3 = à cannelures (SAE C)
4 = à cannelures (SAE CC)

Direction of rotation

R = Clockwise
L = Counter-clockwise

Drehrichtung

R = Rechtslauf
L = Linkslauf

Sens de rotation

R = à droite
L = à gauche

Porting combination

00 = standard

Lage der Anschlüsse

00 = standard

Combinaison des orifices

00 = standard

Design letter

Ausführungsbuchstabe

Conception

Seal class

1 = S1 - BUNA N
4 = S4 - EPDM
5 = S5 - VITON

Dichtungsklasse

1 = S1 - BUNA N
4 = S4 - EPDM
5 = S5 - VITON

Classe de joint

1 = S1 - BUNA N
4 = S4 - EPDM
5 = S5 - VITON

Mounting w/connection variables

4 bolts SAE flange (J518)

Gehäuse-Anschlußgröße

SAE Flansch (J518)

Option sur orifices

Bride SAE 4 trous (J518)

P1 = 1"1/2 - S = 3"1/2		
	UNC	Metric
P2 = 1"	00	M0
P2 = 3/4"	01	M1

P1 = 1"1/2 - S = 3"1/2		
	UNC	Metrisches
P2 = 1"	00	M0
P2 = 3/4"	01	M1

P1 = 1"1/2 - S = 3"1/2		
	UNC	Métrique
P2 = 1"	00	M0
P2 = 3/4"	01	M1

Modifications

Modifikationen

Modifications

Designazione

Clave de designación

Sigla :

Serie T67EC - SAE C - 2 fori
Flangia di montaggio J744

Una lettera può essere aggiunta per specificare parti speciali nella serie

Tipo di cartuccia P1

(Cilindrata) (ml/giro)

042 = 132,3
045 = 142,4
050 = 158,5
052 = 164,8
054 = 171,0

Tipo di cartuccia P2

(Cilindrata) (ml/giro)

003 = 10,8
005 = 17,2
006 = 21,3
008 = 26,4
010 = 34,1
012 = 37,1
014 = 46,0

Tipo di albero

1 = a chiavetta (SAE CC)
2 = a chiavetta (no SAE)
3 = scanalato (SAE C)
4 = scanalato (SAE CC)

Senso di rotazione

R = Orario
L = Antiorario

Orientamento delle bocche

00 = standard

Disegno

Tipo di guarnizioni

1 = S1 - BUNA N
4 = S4 - EPDM
5 = S5 - VITON

Dimensioni delle bocche

Flangia SAE 4 drenaggio (J518)

P1 = 1 ¹ / ₂ - S = 3 ¹ / ₂		
	UNC	Metrica
P2 = 1"	00	M0
P2 = 3/4"	01	M1

Modifiche

Referencia modelo :

Serie T67EC - SAE C - 2 taladros
Brida de montaje J744

Una letra puede ser añadida para especificar piezas especiales en la serie

Aro volumetrico para P1

(Cilindrada) (ml/rev)

066 = 213,3
072 = 227,1
085 = 268,7
057 = 183,3
062 = 196,7

Aro volumetrico para P2

(Cilindrada) (ml/rev)

017 = 58,3
020 = 63,8
022 = 70,3
025 = 79,3
028 = 88,8
031 = 100,0

Tipo de eje

1 = chaveteado (SAE CC)
2 = chaveteado (no SAE)
3 = estriado (SAE C)
4 = estriado (SAE CC)

Sentido de giro

R = Derecha
L = Izquierda

Posición de bocas

00 = estándar

Letra de diseño

Clase de juntas

1 = S1 - BUNA N
4 = S4 - EPDM
5 = S5 - VITON

Conexiones de montaje

Flange SAE 4 fori (J518)

P1 = 1 ¹ / ₂ - S = 3 ¹ / ₂		
	UNC	Metrico
P2 = 1"	00	M0
P2 = 3/4"	01	M1

Modificaciones

T67EC - 085 - 020 - 1 R 00 - A 1 00 - ..