

WHL Series Hoisting Winches

www.comoso.com





Take a look around any city and you'll see lots of winch systems: on tower cranes, lifts on moving trucks, truck-mounted cranes, and highway assistance tow trucks. Also in other areas such as maritime, harbor and military installations and in any activity that requires weights or loads to be lifted.

New Brevini WHL winches are the ideal solution for hoisting applications: we satisfy all market needs.

We have worked to design and produce a wide and complete product range: each unit is classified according to performance, hoisting capacity and motor types, always in compliance with international rules and regulations.

Thanks to their Brevini planetary gear systems inside of the drum, the brakes and a wide range of hydraulic powered units with axial pistons or orbital and electric motors, these WHL winches are extremely versatile and practical. Easy installation and use, great value for money and compact size are the main features of this new range of winches.



WHL Series

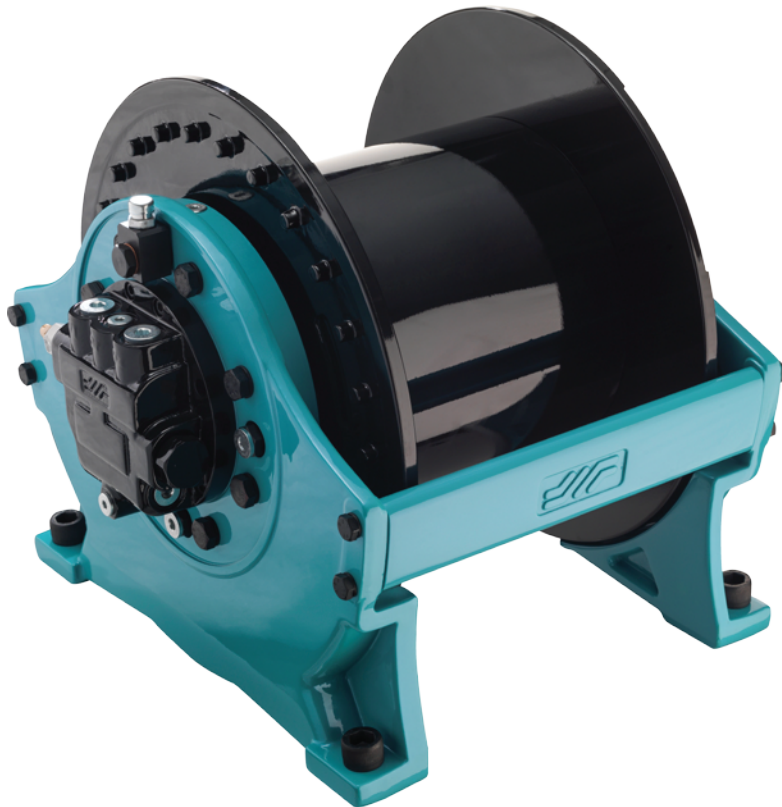

This new range of Winches, with the reliable Brevini planetary gears inside, are the most competitive solution in terms of compactness and flexibility. Brevini WHL winches are available with a variety of ratios, with line pull up to 8,000 Kg.

Brevini planetary gearbox is inside the drum. The minimal space required by the planetary gears makes it possible to produce winches extremely compact. The compactness and

the flexibility with CE marking are the main features of the new WHL range. Every winch is a unit ready to install, so it provides a cost-effective solution in situations in which space is at a premium.

Ideal for lifting and lowering loads of all kinds, these new Brevini hoisting winches are perfect for integration in mobile, marine and loading cranes, stationary crane systems, construction machinery and drilling rigs. They meet all the demands associated with these fields of application - reliably and accurately. This means greater flexibility, higher productivity and considerable time saving. Furthermore they have been designed to resist to aggressive weather conditions.

Designing to exact safety requirements is central to product development, as is a commitment to reliable performance and to the world's environment. Based on a combination of innovative solutions, experienced engineers and use of best practice, our designs provide safe, efficient and cost competitive applications for every use.

Description



1 - 2 / 3 / 4 - 5 - 6 / 7 - 8

1

Family size



2

Gearbox position

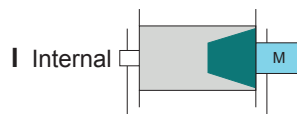

3

Line pull TOP layer

0,7	<i>0,7 ton</i>	<i>700 Kg</i>
0,8	<i>0,8 ton</i>	<i>800 Kg</i>
1,0	<i>1,0 ton</i>	<i>1000 Kg</i>
...		...
6,0	<i>6 ton</i>	<i>6000 Kg</i>

4

Drum configuration and rope diameter ϕ

SDϕ	Smooth	
GDϕHL	Helical left grooved	
GDϕHR	Helical right grooved	
GDϕLL	Left grooved "lebus style"	
GDϕLR	Right grooved "lebus style"	

5

Drum rotation

01	Clockwise (viewed from the motor side)	
02	Counter-clockwise (viewed from the motor side)	
00	None or double Overcenter valve, no motor, not defined (only for smooth drum, grooved drum with more than one thread)	

6

Ratio

Ratio	Decimals	Example
<10	X,X	<i>5,1</i>
<200	XXX,X	<i>110,3</i>
>200	XXX	<i>250</i>

Description



1 - 2 / 3 / 4 - 5 - 6 / 7 - 8

7

Adaptor flange - motor position

In case of:	To be written	Example
Adaptor flange	611xxxxxxxxx 130xxxx	.../61101801480-...
Universal input	E00	.../E00-...
Motor	Motor type Displacement_position	BRZV

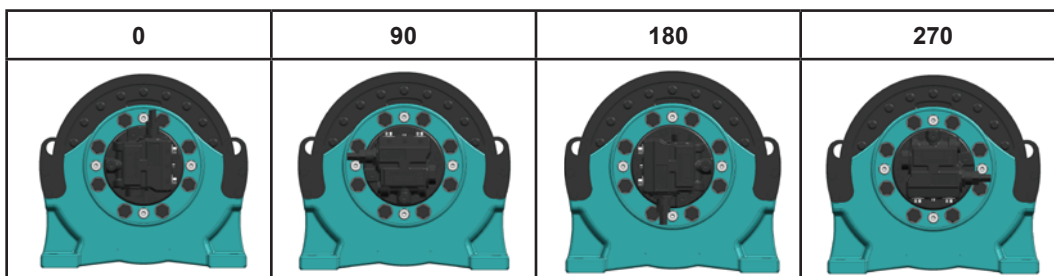

For a motor with an integrated valve (example BRZV) it is possible to have frontal ports as an option. In this case the letter "F" identifies their frontal position

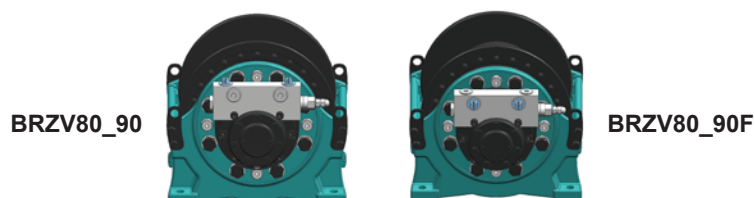

8

Accessories

PRESSURE ROLLER	
	Not present
P	Present

ROPE	
	Not present
R	Present

CONTROLS	
	Not present
TL	Torque limiter sensor
EN	Encoder
EL	Electric control system
HL	Hydraulic Limit Switch

Model code examples

WHL025-I/1,4/SD12-01/14/BRZV80_90 (StdDLA-MinDLB-BT298-) C5MH RAL9005_50

F.E.M. Standard



Table N°1

Crane type classification guide		According to FEM section I, 3rd edition, Table T.2.1.3.5	
Type of crane	Type of duty	Type of mechanism	
		Hoisting	Luffing
Erection cranes		M2 - M3	M1 - M2
Loading bridge cranes	Hook duty	M5 - M6	-
	Grab or magnet duty	M7 - M8	-
Workshop cranes		M6	-
Overhead travelling cranes, pig-breaking cranes, scrapyard cranes	Grab or magnet duty	M8	-
Bridge cranes for unloading, bridge cranes for containers	a) Hook or spreader duty	M6 - M7	M3 - M4
Other bridge cranes (with crab, and/or slewing jib)	b) Hook duty	M4 - M5	-
Bridge cranes for unloading, bridge cranes (with crab, and/or slewing jib)	Grab or magnet duty	M8	M3 - M4
Dry dock cranes, shipyard jib cranes, jib ceanes for dismantling	Hook duty	M5 - M6	M4 - M5
Dockside cranes (slewing, on ganty, etc.), floating cranes and pontoon derricks	Hook duty	M6 - M7	M5 - M6
	Grab or magnet duty	M7 - M8	M6 - M7
Floating cranes and pontoon derricks for very heavy loads (usually greater than 100 t)	Hook duty	M3 - M4	M3 - M4
Deck cranes	Hook duty	M4	M3 - M4
	Grab or magnet duty	M5 - M6	
Tower cranes for building		M4	M4
Derricks		M2 - M3	M1 - M2
Railway cranes allowed to run in a train		M3 - M4	M2 - M3
Mobile cranes	Hook duty	M3 - M4	M2 - M3

Table N°2

CLASSES OF UTILIZATION								
		T2	T3	T4	T5	T6	T7	T8
Classes of utilisation (Table T.2.1.3.4.)		400 < T2 800	800 < T3 1600	1600 < T4 3200	3200 < T5 6300	6300 < T6 12500	12500 < T7 25000	25000 < T8 50000
L1	0 > Km 0,125		M2	M3	M4	M5	M6	M7
L2	0,125 > Km 0,250	M2	M3	M4	M5	M6	M7	M8
L3	0,250 > Km 0,500	M3	M4	M5	M6	M7	M8	
L4	0,500 > Km 1000	M4	M5	M6	M7	M8		

Table N°3

Mechanism Group	Drums	Pulleys	Compensating Pulleys
M 1	11,2	12,5	11,2
M 2	12,5	14	12,5
M 3	14	16	12,5
M 4	16	18	14
M 5	18	20	14
M 6	20	22,4	16
M 7	22,4	25	16
M 8	25	28	18

For more information please contact the Brevini Sales Dept.

WHL015-I/0,7

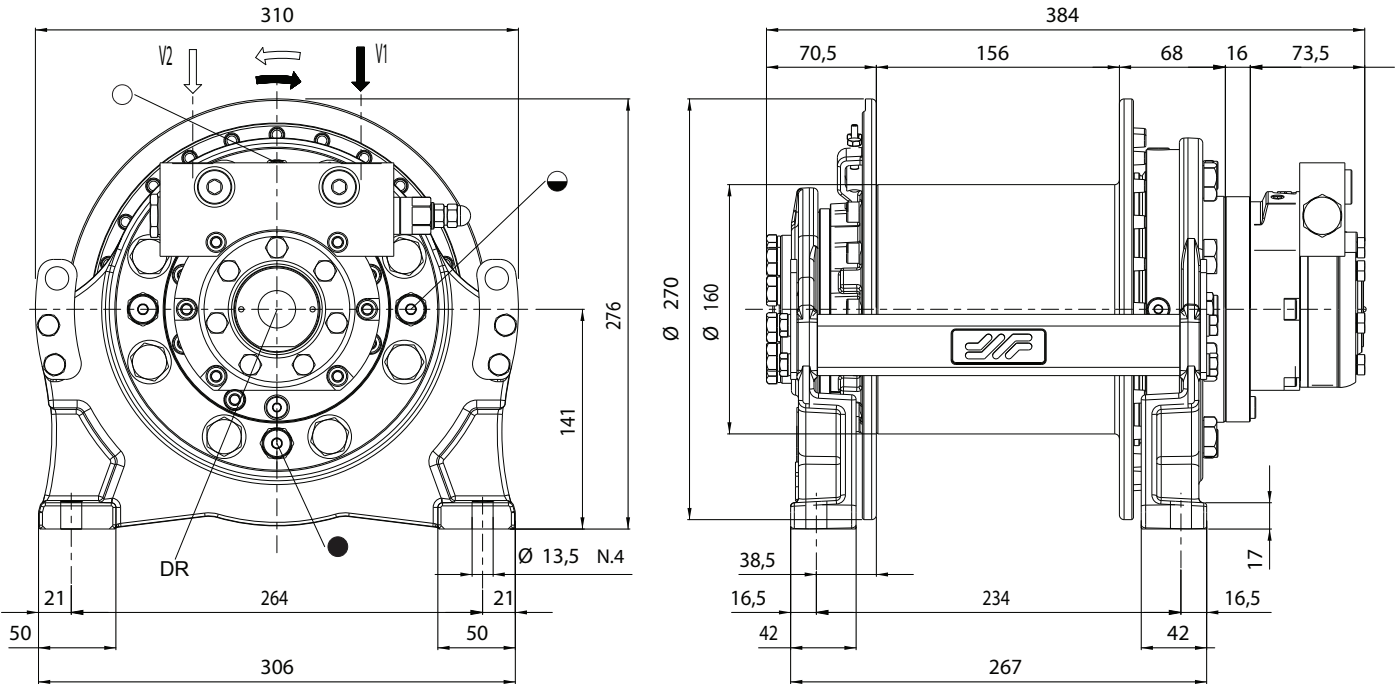
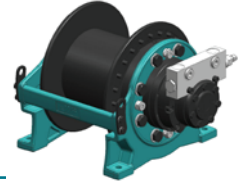

⁽³⁾ ○ Filling plug ● Oil level plug ● Drain plug

Rope layer	n°	1	2	3	4	5	6 Full drum
Line pull	[kg]	1000	950	850	800	750	.. ⁽¹⁾
Rope speed with 60 [l/min]	[m/min]	54	59	65	70	76	-
Rope length	[m]	9	20	32	45	59	74

Starting lifting pressure	175	[bar]	Recommended rope diameter		8	[mm]
Max. back pressure on return line	5	[bar]	Oil quantity		0,8	[l]
Maximum pump delivery	60	[l/min]	Weight		55	[kg]
Minimum pump delivery	8	[l/min]	Lubrication plug		G1/4	○ ● ● ⁽³⁾
Motor displacement	100	[cm ³ /rev]	Lifting port		G3/8	V1
Static braking torque	395	[Nm]	Lowering port		G3/8	V2
Gear ratio	5	[i :]	Drain port		G1/4	DR ⁽²⁾

Winch mechanisms classification in agreement with F.E.M. (1.001) (Third edition revised on 01.10.1998)	n ₂ = 25 rpm	M6(T6-L2)
--	-------------------------	-----------

Always keep at least 3 wraps of rope on the drum for safety reasons

To fix the winch use screws 8.8 grade

Technical features may change with no previous notice from the manufacturer

THE PRESENT EQUIPMENT MUST NOT BE USED TO LIFT PEOPLE

WHL015-I/1,0

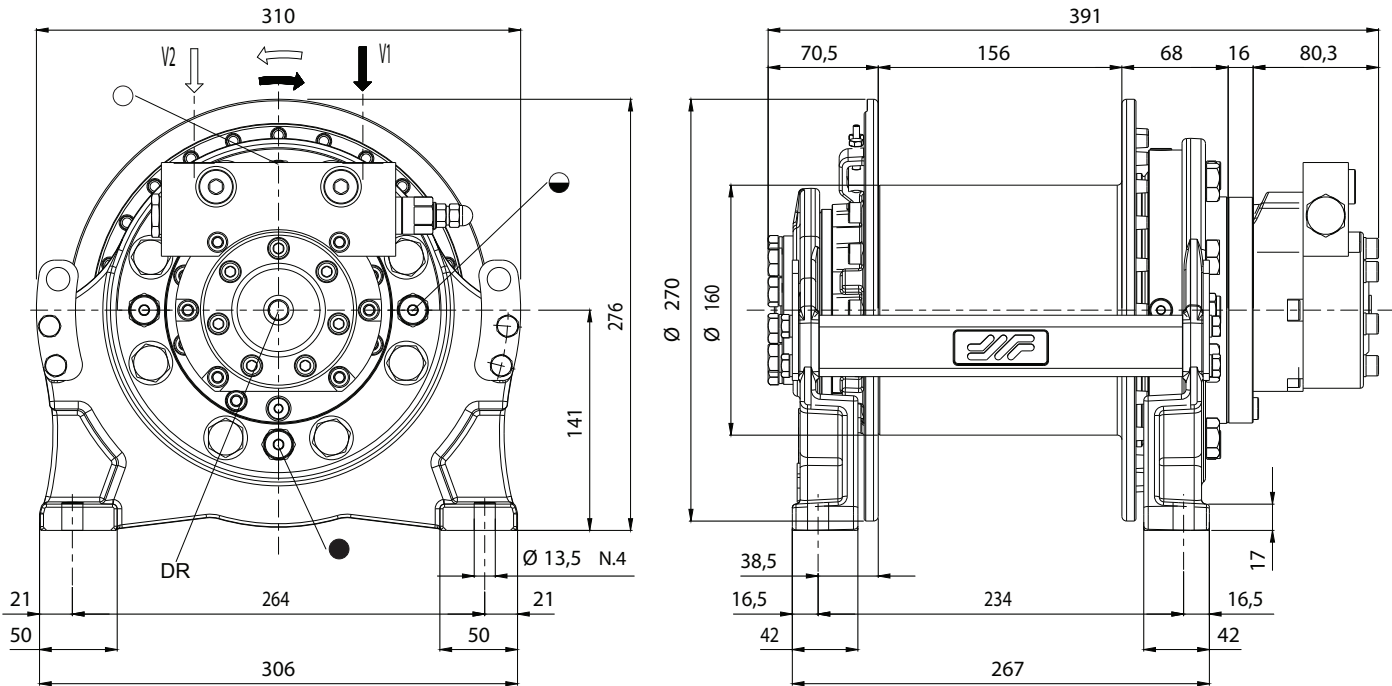
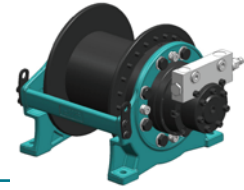

⁽³⁾ ○ Filling plug ● Oil level plug ● Drain plug

Rope layer	n°	1	2	3	4	5	6
Line pull	[kg]	1400	1250	1100	1000	Full drum	-
Rope speed with 50 [l/min]	[m/min]	36	41	45	50	-	-
Rope length	[m]	8	17	27	38	49	-

Starting lifting pressure	195	[bar]	Recommended rope diameter	10	[mm]
Max. back pressure on return line	5	[bar]	Oil quantity	0,8	[l]
Maximum pump delivery	60	[l/min]	Weight	55	[kg]
Minimum pump delivery	8	[l/min]	Lubrication plug	G1/4	○ ● ● ⁽³⁾
Motor displacement	125,7	[cm ³ /rev]	Lifting port	G3/8	V1
Static braking torque	395	[Nm]	Lowering port	G3/8	V2
Gear ratio	5	[i :]	Drain port	G1/4	DR ⁽²⁾

Winch mechanisms classification in agreement with F.E.M. (1.001) (Third edition revised on 01.10.1998)

$n_2 = 25$ rpm

M4(T4-L2)

Always keep at least 3 wraps of rope on the drum for safety reasons

To fix the winch use screws 8.8 grade

Technical features may change with no previous notice from the manufacturer

THE PRESENT EQUIPMENT MUST NOT BE USED TO LIFT PEOPLE

WHL025-I/1,1

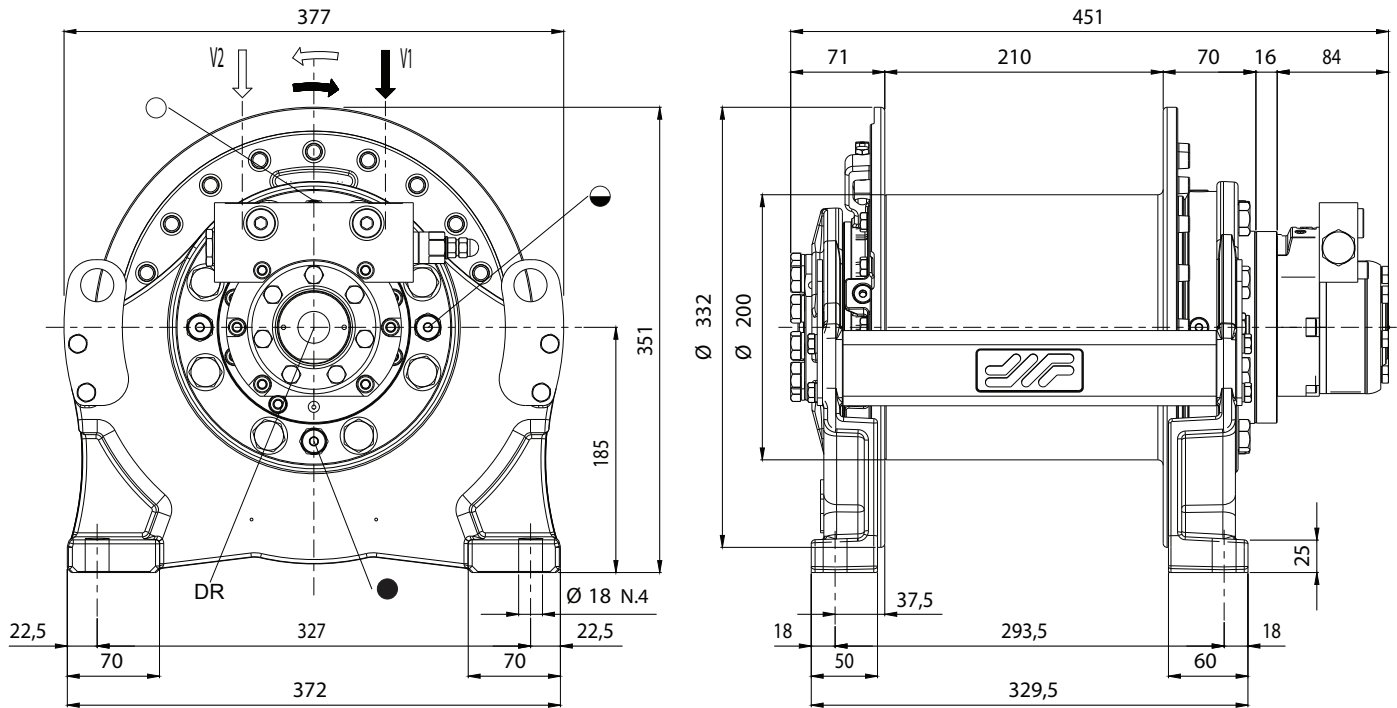
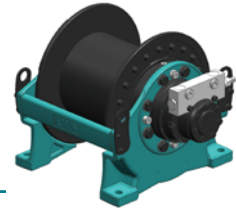

⁽³⁾ ○ Filling plug ● Oil level plug ● Drain plug

Rope layer	n°	1	2	3	4	5	6 Full drum
Line pull	[kg]	1600	1450	1300	1200	1150	-(⁽¹⁾)
Rope speed with 60 [l/min]	[m/min]	40	44	48	53	57	-
Rope length	[m]	13	28	43	61	79	99

Starting lifting pressure	195	[bar]	Recommended rope diameter		10	[mm]
Max. back pressure on return line	5	[bar]	Oil quantity		1,5	[l]
Maximum pump delivery	60	[l/min]	Weight		85	[kg]
Minimum pump delivery	8	[l/min]	Lubrication plug		G1/4	○ ● ● ⁽³⁾
Motor displacement	160	[cm ³ /rev]	Lifting port		G3/8	V1
Static braking torque	510	[Nm]	Lowering port		G3/8	V2
Gear ratio	5,15	[i :]	Drain port		G1/4	DR ⁽²⁾

Winch mechanisms classification in agreement with F.E.M. (1.001) (Third edition revised on 01.10.1998)

$n_2 = 25$ rpm

M5(T5-L2)

Always keep at least 3 wraps of rope on the drum for safety reasons

To fix the winch use screws 8.8 grade

Technical features may change with no previous notice from the manufacturer

THE PRESENT EQUIPMENT MUST NOT BE USED TO LIFT PEOPLE

WHL025-I/1,4

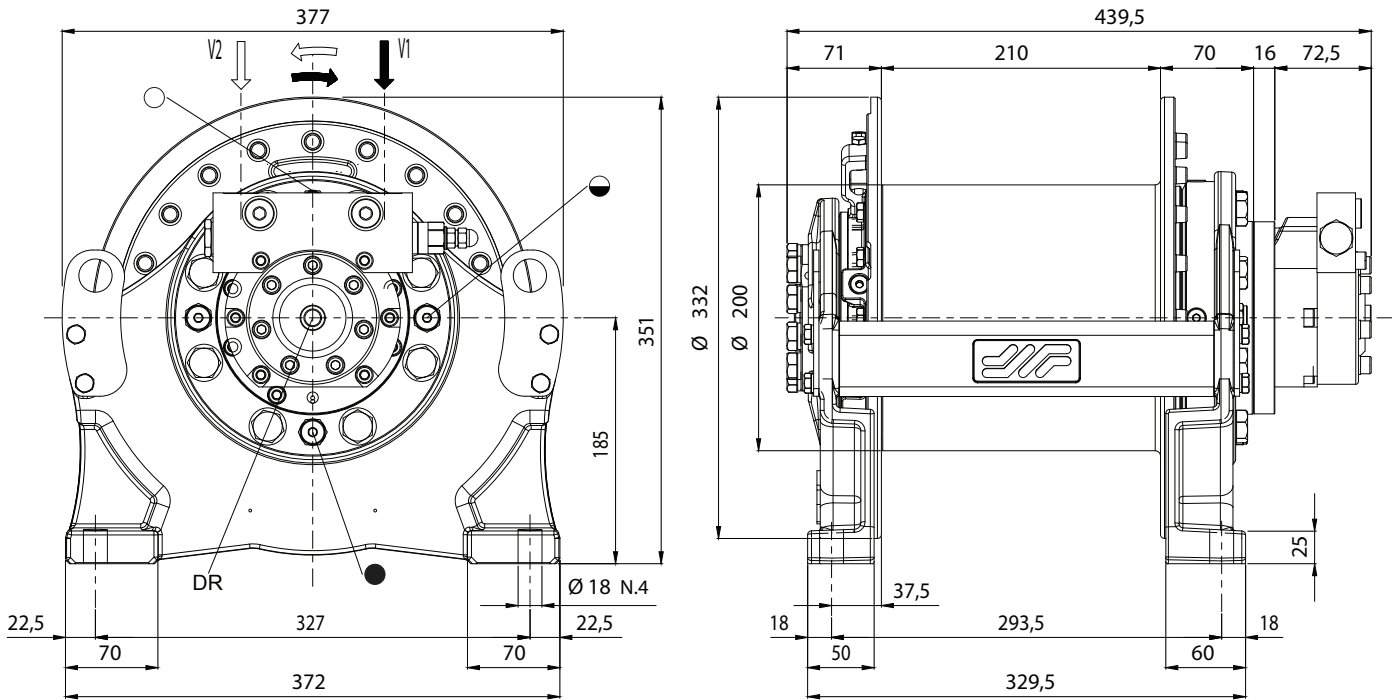
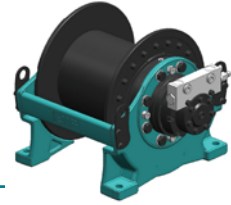

⁽³⁾ ○ Filling plug ● Oil level plug ● Drain plug

Rope layer	n°	1	2	3	4	5 Full drum	6
Line pull	[kg]	2000	1750	1600	1450	-(¹)	-
Rope speed with 60 [l/min]	[m/min]	30	34	37	41	-	-
Rope length	[m]	11	23	37	52	69	-
Starting lifting pressure	200 [bar]	Recommended rope diameter		12 [mm]			
Max. back pressure on return line	5 [bar]	Oil quantity		1,4 [l]			
Maximum pump delivery	60 [l/min]	Weight		90 [kg]			
Minimum pump delivery	8 [l/min]	Lubrication plug		G1/4 ○ ● ● ⁽³⁾			
Motor displacement	80 [cm ³ /rev]	Lifting port		G3/8 V1			
Static braking torque	298 [Nm]	Lowering port		G3/8 V2			
Gear ratio	14 [i :]	Drain port		G1/4 DR ⁽²⁾			

Winch mechanisms classification in agreement with F.E.M. (1.001) (Third edition revised on 01.10.1998)

$n_2 = 25$ rpm

M4(T4-L2)

Always keep at least 3 wraps of rope on the drum for safety reasons

To fix the winch use screws 8.8 grade

Technical features may change with no previous notice from the manufacturer

THE PRESENT EQUIPMENT MUST NOT BE USED TO LIFT PEOPLE

WHL025-I/1,4

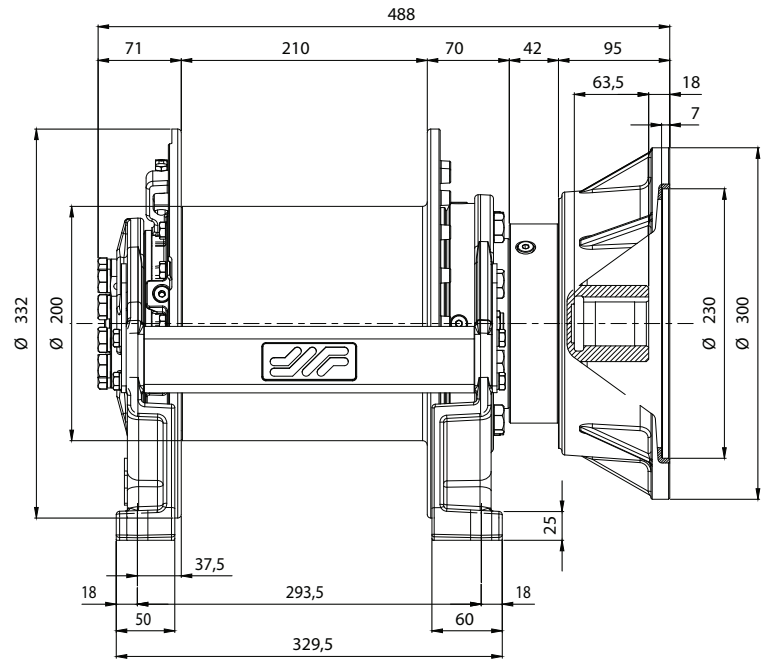
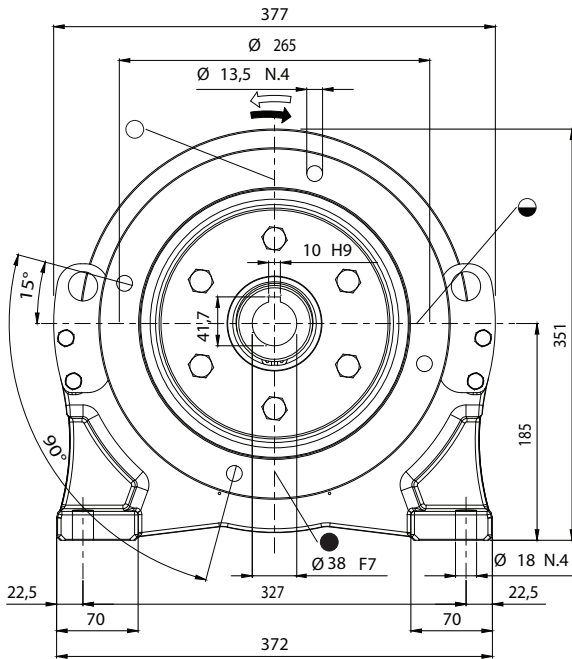
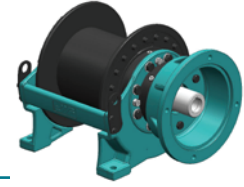

⁽³⁾ ○ Filling plug ● Oil level plug ● Drain plug

Electric motor not supplied as standard

Rope layer	n°	1	2	3	4	5 Full drum	6
Line pull	[kg]	2000	1800	1600	1450	-(¹)	-
Rope speed with	[m/min]	29	33	36	40	-	-
Rope length	[m]	11	23	37	52	69	-

Rated Power	11	[kW]	Recommended rope diameter	12	[mm]
Frequency	50	[Hz]	Oil quantity	1,4	[l]
Input rev. per minute (4 poles)	1410	[rpm]	Weight	90	[kg]
Nominal voltage	400	[Volt]	Lubrication plug	G1/4	○ ● ● ⁽³⁾
Motor size - mounting configuration	IEC132	B5	Lifting port	-	V1
Static braking torque	100 ^(*)	[Nm]	Lowering port	-	V2
Gear ratio	31,5	[i :]	Drain port	-	DR ⁽²⁾

Winch mechanisms classification in agreement with F.E.M. (1.001) (Third edition revised on 01.10.1998)	n ₂ = 25 rpm	M4(T4-L2)
--	-------------------------	-----------

Always keep at least 3 wraps of rope on the drum for safety reasons

To fix the winch use screws 8.8 grade

Technical features may change with no previous notice from the manufacturer

THE PRESENT EQUIPMENT MUST NOT BE USED TO LIFT PEOPLE

^(*) = Safety factor of the braking static torque 1,5

WHL025-I/1,9

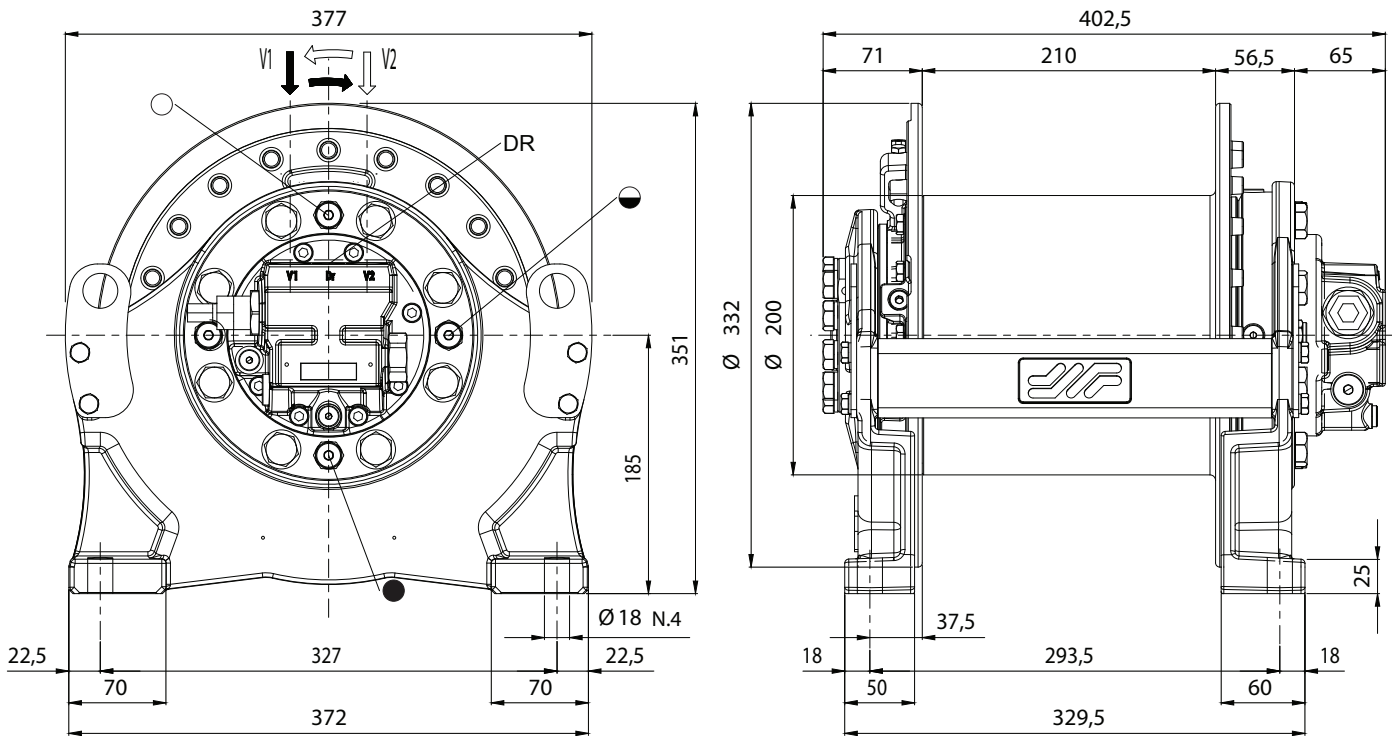
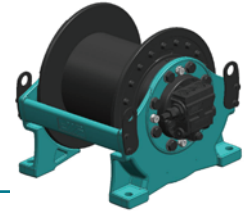

⁽³⁾ ○ Filling plug ● Oil level plug ● Drain plug

Rope layer	n°	1	2	3	4	5 Full drum	6
Line pull	[kg]	2650	2350	2100	1950	-(¹)	-
Rope speed with 60 [l/min]	[m/min]	55	62	68	75	-	-
Rope length	[m]	11	23	37	52	69	-
Starting lifting pressure	340 [bar]	Recommended rope diameter		12 [mm]			
Max. back pressure on return line	5 [bar]	Oil quantity		1,4 [l]			
Maximum pump delivery	60 [l/min]	Weight		90 [kg]			
Minimum pump delivery	5 [l/min]	Lubrication plug		G1/4 ○ ● ● ⁽³⁾			
Motor displacement	21 [cm ³ /rev]	Lifting port		3/4-16 UNF V1			
Static braking torque	178 [Nm]	Lowering port		3/4-16 UNF V2			
Gear ratio	31,5 [i :]	Drain port		1/2-20 UNF DR ⁽²⁾			

Winch mechanisms classification in agreement with F.E.M. (1.001) (Third edition revised on 01.10.1998)

$n_2 = 25$ rpm

M4(T4-L2)

Always keep at least 3 wraps of rope on the drum for safety reasons

To fix the winch use screws 8.8 grade

Technical features may change with no previous notice from the manufacturer

THE PRESENT EQUIPMENT MUST NOT BE USED TO LIFT PEOPLE

WHL025-1/2,0

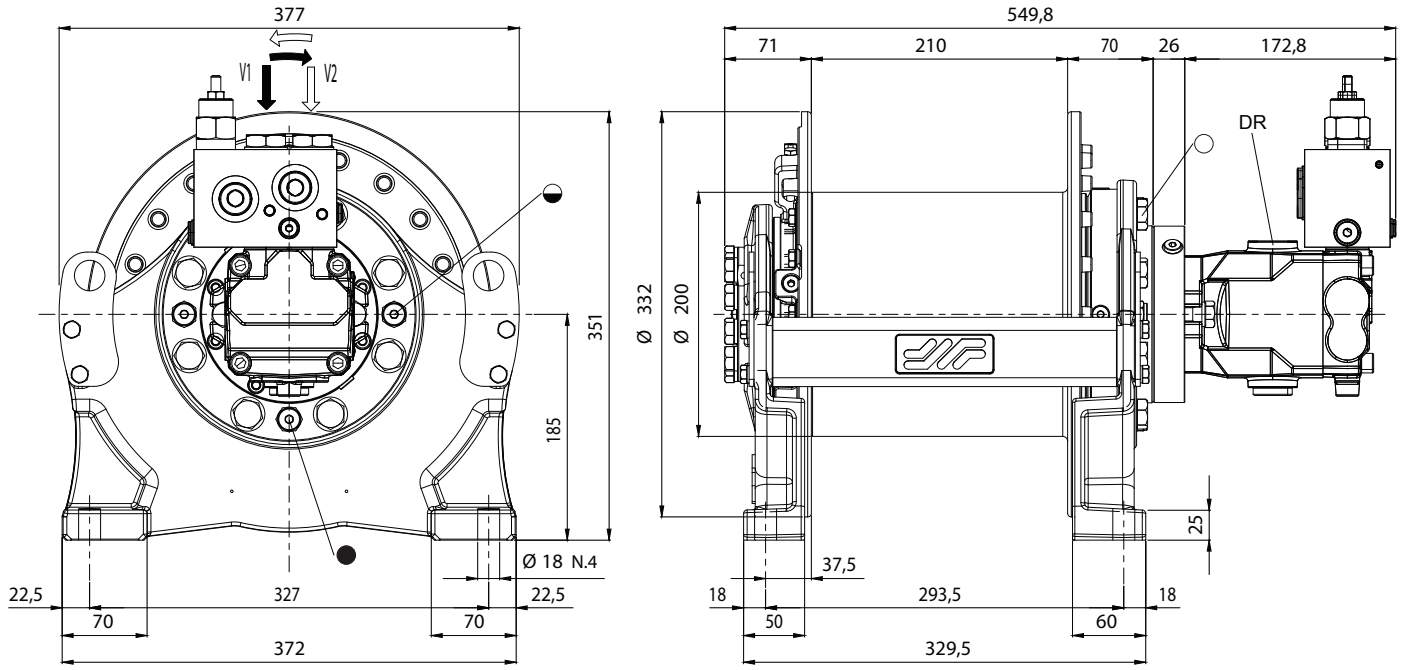
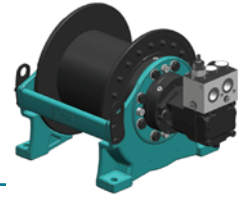

⁽³⁾ ○ Filling plug ● Oil level plug ● Drain plug

Rope layer	n°	1	2	3	4	5 Full drum	6
Line pull	[kg]	2700	2400	2150	2000	-(¹)	-
Rope speed with 90 [l/min]	[m/min]	75	84	92	101	-	-
Rope length	[m]	11	23	37	52	69	-
Starting lifting pressure	315 [bar]	Recommended rope diameter		12 [mm]			
Max. back pressure on return line	5 [bar]	Oil quantity		1,4 [l]			
Maximum pump delivery	100 [l/min]	Weight		90 [kg]			
Minimum pump delivery	5 [l/min]	Lubrication plug		G1/4 ○ ● ● ⁽³⁾			
Motor displacement	28 [cm ³ /rev]	Lifting port		G3/4 V1			
Static braking torque	298 [Nm]	Lowering port		G3/4 V2			
Gear ratio	26,5 [i :]	Drain port		G3/4 DR ⁽²⁾			

Winch mechanisms classification in agreement with F.E.M. (1.001) (Third edition revised on 01.10.1998)

$n_2 = 25$ rpm

M4(T4-L2)

Always keep at least 3 wraps of rope on the drum for safety reasons

To fix the winch use screws 8.8 grade

Technical features may change with no previous notice from the manufacturer

THE PRESENT EQUIPMENT MUST NOT BE USED TO LIFT PEOPLE

WHL025-1/2,0

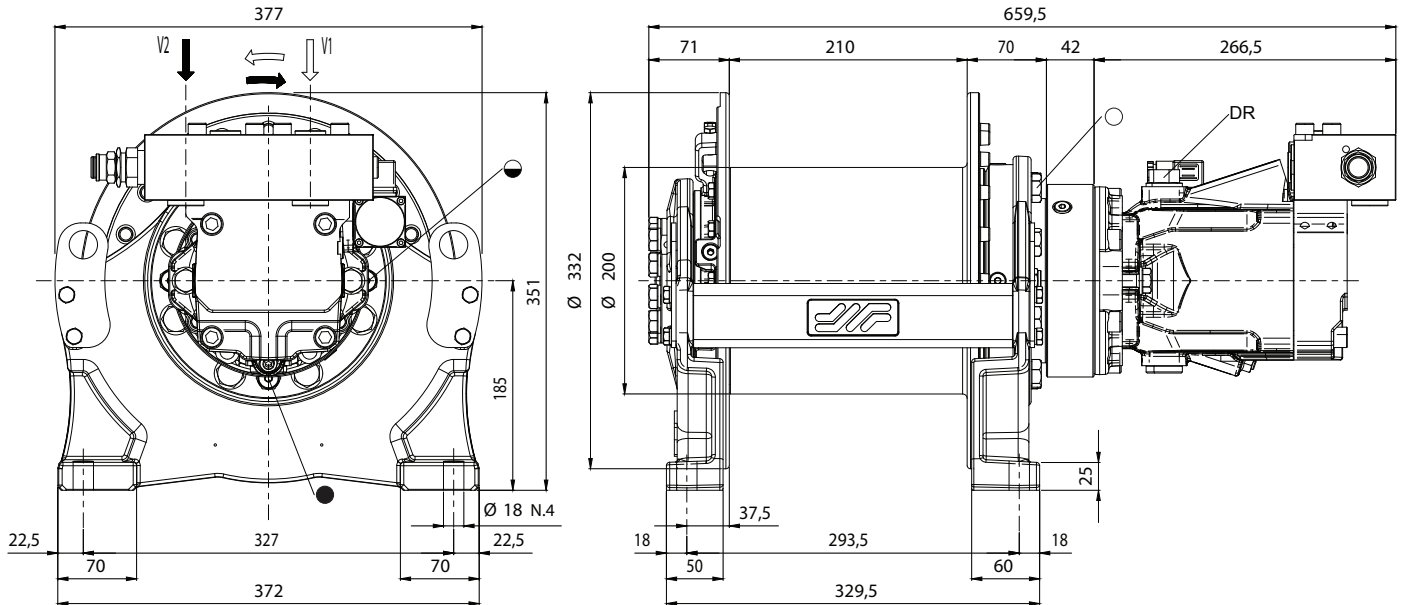
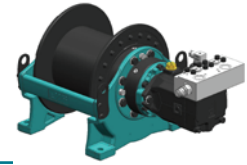

⁽³⁾ ○ Filling plug ● Oil level plug ● Drain plug

Rope layer	n°	1	2	3	4	5 Full drum	6
Line pull	[kg]	2700 / 1500	2400 / 1350	2200 / 1200	2000 / 1100	-(¹)	-
Rope speed with 80 [l/min]	[m/min]	46 / 82	51 / 92	57 / 102	62 / 112	-	-
Rope length	[m]	11	23	37	52	69	-
Starting lifting pressure	220 [bar]	Recommended rope diameter		12 [mm]			
Max. back pressure on return line	5 [bar]	Oil quantity		1,4 [l]			
Maximum pump delivery	100 [l/min]	Weight		90 [kg]			
Minimum pump delivery	10 [l/min]	Lubrication plug		G1/4 ○ ● ● ⁽³⁾			
Motor displacement	34 / 19 [cm ³ /rev]	Lifting port		G3/4 V2			
Static braking torque	298 [Nm]	Lowering port		G3/4 V1			
Gear ratio	31,5 [i :]	Drain port		G3/4 DR ⁽²⁾			

Winch mechanisms classification in agreement with F.E.M. (1.001) (Third edition revised on 01.10.1998)

$n_2 = 25$ rpm

M4(T4-L2)

Always keep at least 3 wraps of rope on the drum for safety reasons

To fix the winch use screws 8.8 grade

Technical features may change with no previous notice from the manufacturer

THE PRESENT EQUIPMENT MUST NOT BE USED TO LIFT PEOPLE

WHL045-1/2,0

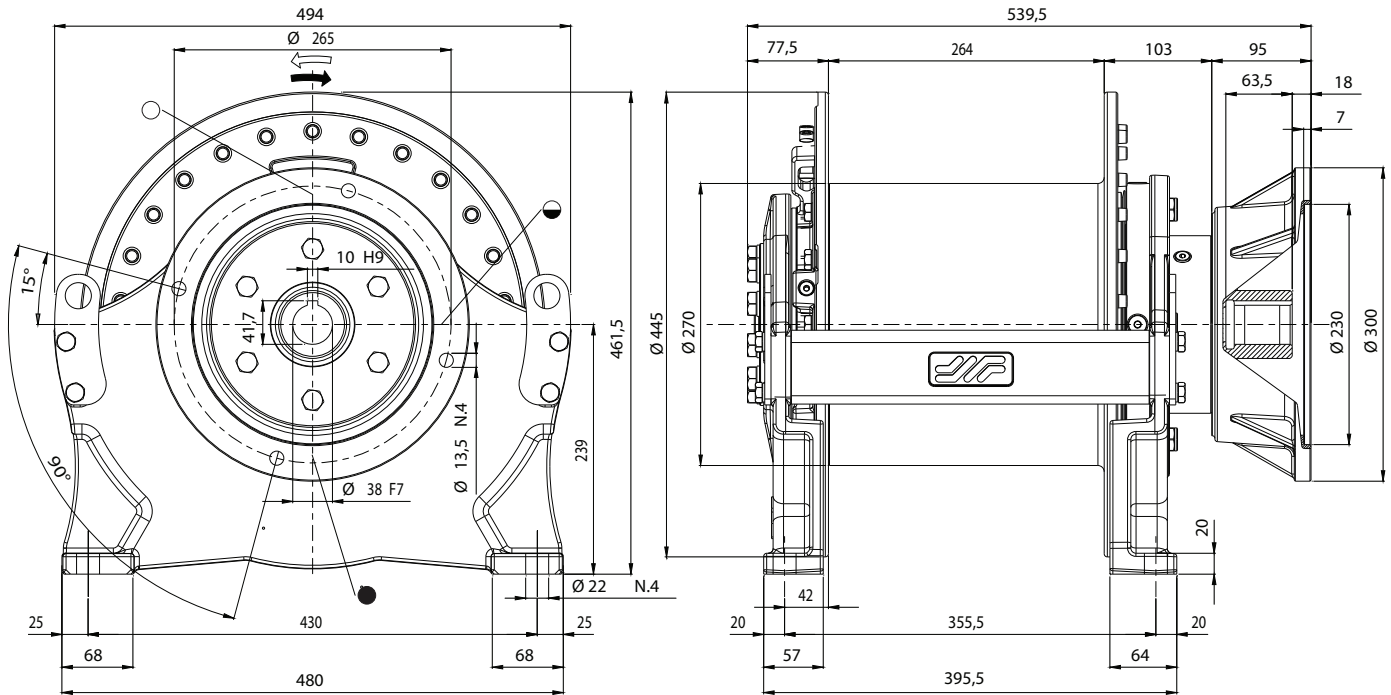
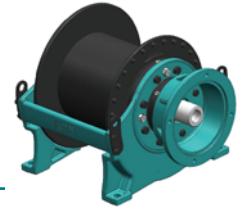

⁽³⁾ ○ Filling plug ● Oil level plug ● Drain plug

Electric motor not supplied as standard

Rope layer	n°	1	2	3	4	5	6 Full drum
Line pull	[kg]	2700	2500	2300	2150	2000	.. ⁽¹⁾
Rope speed with	[m/min]	20	22	24	26	27	-
Rope length	[m]	18	39	61	85	110	137

Rated Power	11	[kW]	Recommended rope diameter		12	[mm]
Frequency	50	[Hz]	Oil quantity		3	[l]
Input rev. per minute (4 poles)	1410	[rpm]	Weight		180	[kg]
Nominal voltage	400	[Volt]	Lubrication plug		G3/8	○ ● ● ⁽³⁾
Motor size - mounting configuration	IEC132	B5	Lifting port		-	V1
Static braking torque	95 ⁽¹⁾	[Nm]	Lowering port		-	V2
Gear ratio	60,79	[i :]	Drain port		-	DR ⁽²⁾

Winch mechanisms classification in agreement with F.E.M. (1.001) (Third edition revised on 01.10.1998)	n ₂ = 25 rpm	M7(T9-L2)
--	-------------------------	-----------

Always keep at least 3 wraps of rope on the drum for safety reasons
To fix the winch use screws 8.8 grade
Technical features may change with no previous notice from the manufacturer

THE PRESENT EQUIPMENT MUST NOT BE USED TO LIFT PEOPLE

⁽¹⁾ = Safety factor of the braking static torque 1,5

WHL045-I/3,0

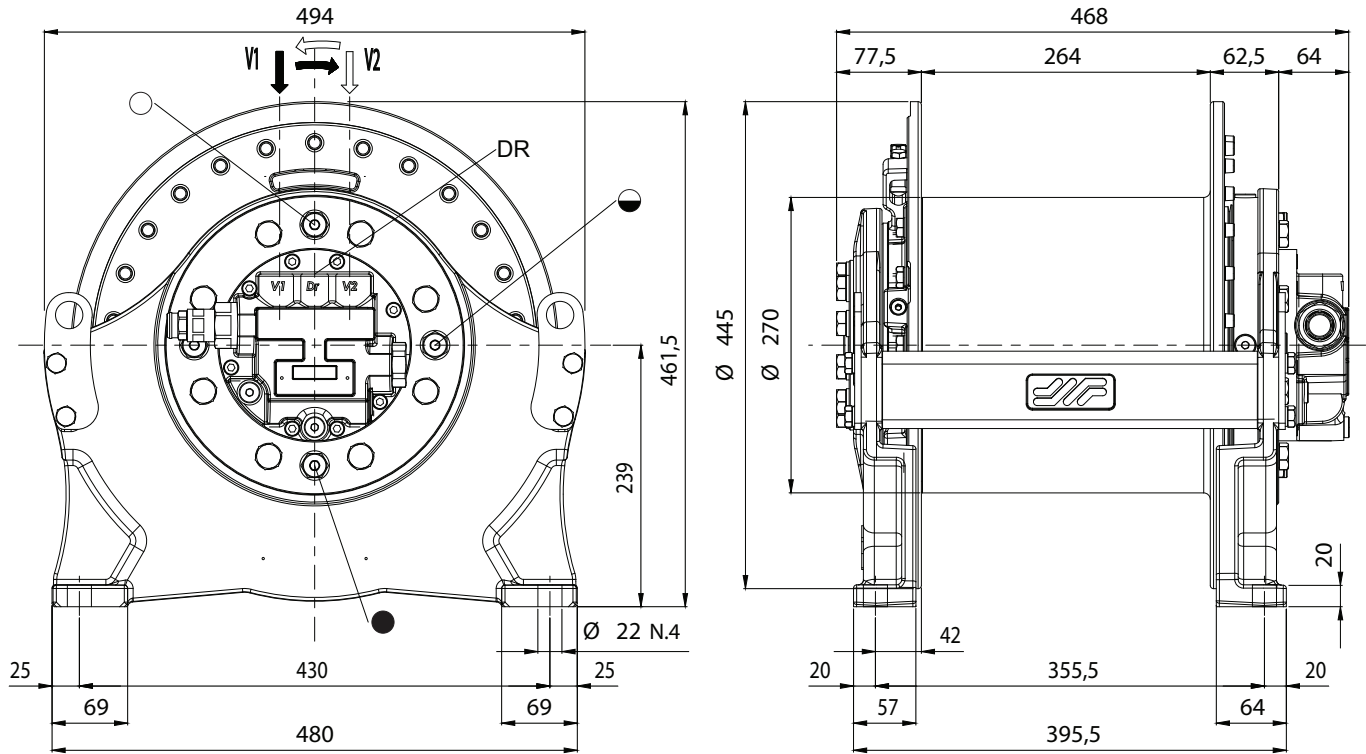

⁽³⁾ ○ Filling plug ● Oil level plug ● Drain plug

Rope layer	n°	1	2	3	4	5 Full drum	6
Line pull	[kg]	4150	3700	3350	3050	-(¹)	-
Rope speed with 85 [l/min]	[m/min]	51	56	62	68	-	-
Rope length	[m]	16	34	54	74	95	-
Starting lifting pressure	350 [bar]	Recommended rope diameter		14 [mm]			
Max. back pressure on return line	5 [bar]	Oil quantity		3 [l]			
Maximum pump delivery	100 [l/min]	Weight		172 [kg]			
Minimum pump delivery	10 [l/min]	Lubrication plug		G3/8 ○ ● ● ⁽³⁾			
Motor displacement	37 [cm ³ /rev]	Lifting port		7/8-14 UNF V1			
Static braking torque	280 [Nm]	Lowering port		7/8-14 UNF V2			
Gear ratio	38,22 [i :]	Drain port		9/16-18 UNF DR ⁽²⁾			

Winch mechanisms classification in agreement with F.E.M. (1.001) (Third edition revised on 01.10.1998)

$n_2 = 25$ rpm

M4(T4-L2)

Always keep at least 3 wraps of rope on the drum for safety reasons

To fix the winch use screws 8.8 grade

Technical features may change with no previous notice from the manufacturer

THE PRESENT EQUIPMENT MUST NOT BE USED TO LIFT PEOPLE

WHL045-1/3,5

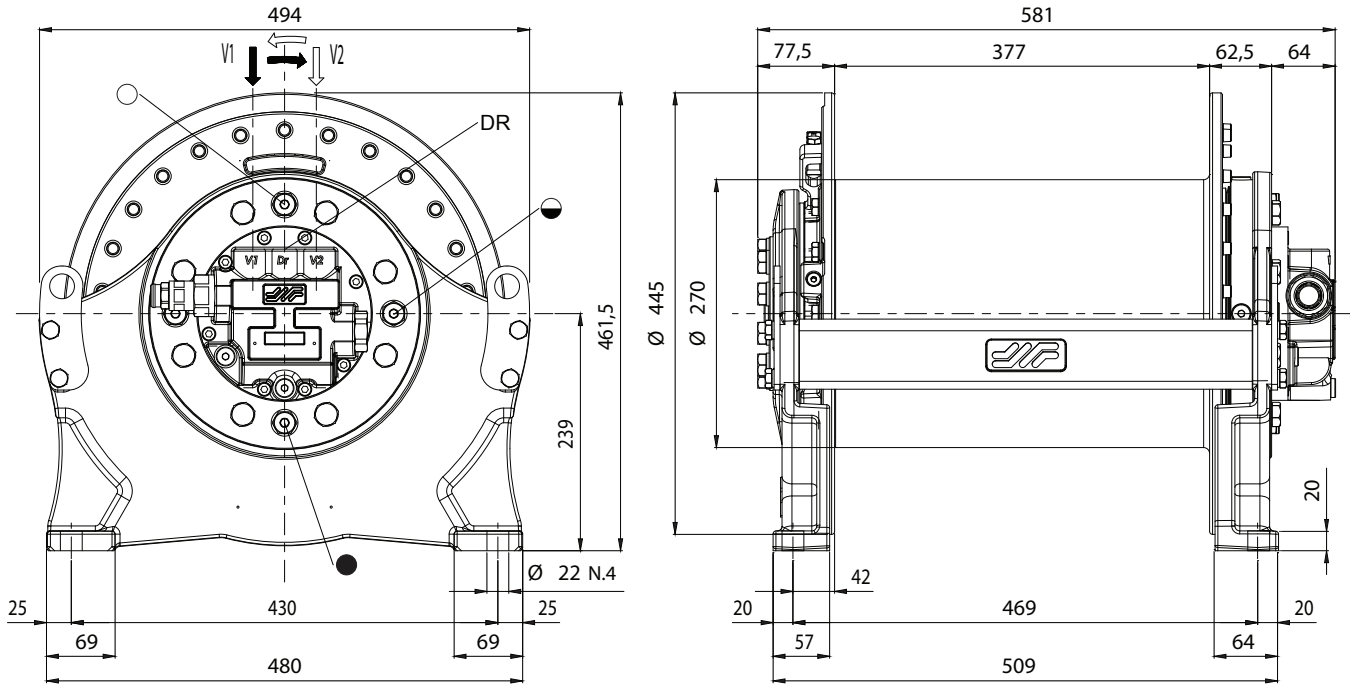
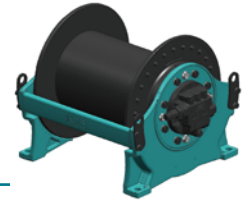

⁽³⁾ ○ Filling plug ● Oil level plug ● Drain plug

Rope layer	n°	1	2	3	4	5 Full drum	6
Line pull	[kg]	5150	4600	4150	3800	-(¹)	-
Rope speed with 90 [l/min]	[m/min]	38	43	47	52	-	-
Rope length	[m]	20	42	67	95	125	-
Starting lifting pressure	320 [bar]	Recommended rope diameter		16 [mm]			
Max. back pressure on return line	5 [bar]	Oil quantity		4,5 [l]			
Maximum pump delivery	100 [l/min]	Weight		230 [kg]			
Minimum pump delivery	10 [l/min]	Lubrication plug		G3/8 ○ ● ● ⁽³⁾			
Motor displacement	37 [cm ³ /rev]	Lifting port		7/8-14 UNF V1			
Static braking torque	280 [Nm]	Lowering port		7/8-14 UNF V2			
Gear ratio	52,78 [i :]	Drain port		9/16-18 UNF DR ⁽²⁾			

Winch mechanisms classification in agreement with F.E.M. (1.001) (Third edition revised on 01.10.1998)

$n_2 = 25$ rpm

M4(T4-L2)

Always keep at least 3 wraps of rope on the drum for safety reasons

To fix the winch use screws 8.8 grade

Technical features may change with no previous notice from the manufacturer

THE PRESENT EQUIPMENT MUST NOT BE USED TO LIFT PEOPLE

WHL045-I/3,5

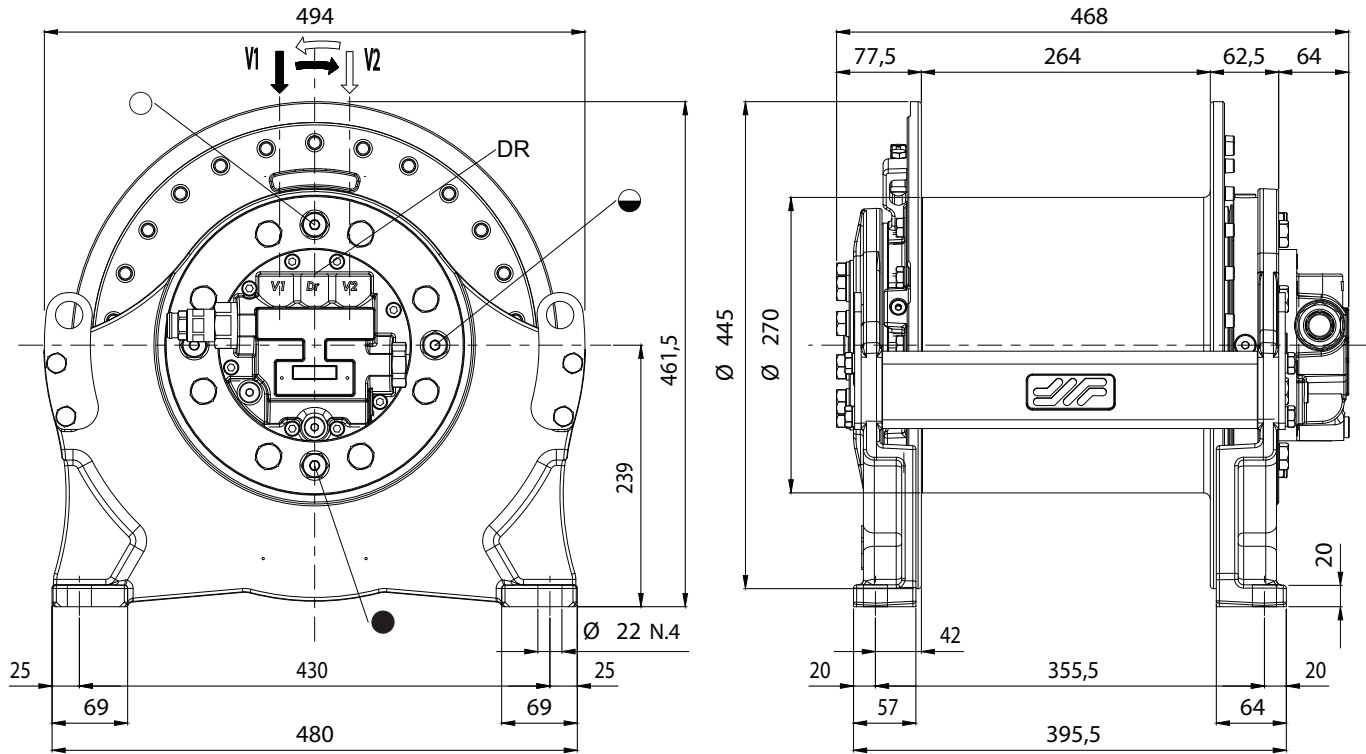
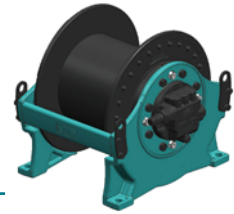

⁽³⁾ ○ Filling plug ● Oil level plug ● Drain plug

Rope layer	n°	1	2	3	4	5 Full drum	6
Line pull	[kg]	5150	4600	4150	3800	-(¹)	-
Rope speed with 90 [l/min]	[m/min]	34	38	42	46	-	-
Rope length	[m]	14	30	47	67	88	-

Starting lifting pressure	285	[bar]	Recommended rope diameter	16	[mm]
Max. back pressure on return line	5	[bar]	Oil quantity	3	[l]
Maximum pump delivery	100	[l/min]	Weight	180	[kg]
Minimum pump delivery	10	[l/min]	Lubrication plug	G3/8	○ ● ● ⁽³⁾
Motor displacement	37	[cm ³ /rev]	Lifting port	7/8-14 UNF	V1
Static braking torque	280	[Nm]	Lowering port	7/8-14 UNF	V2
Gear ratio	60,16	[i :]	Drain port	9/16-18 UNF	DR ⁽²⁾

Winch mechanisms classification in agreement with F.E.M. (1.001) (Third edition revised on 01.10.1998)

$n_2 = 25$ rpm

M4(T4-L2)

Always keep at least 3 wraps of rope on the drum for safety reasons

To fix the winch use screws 8.8 grade

Technical features may change with no previous notice from the manufacturer

THE PRESENT EQUIPMENT MUST NOT BE USED TO LIFT PEOPLE

WHL045-1/3,5

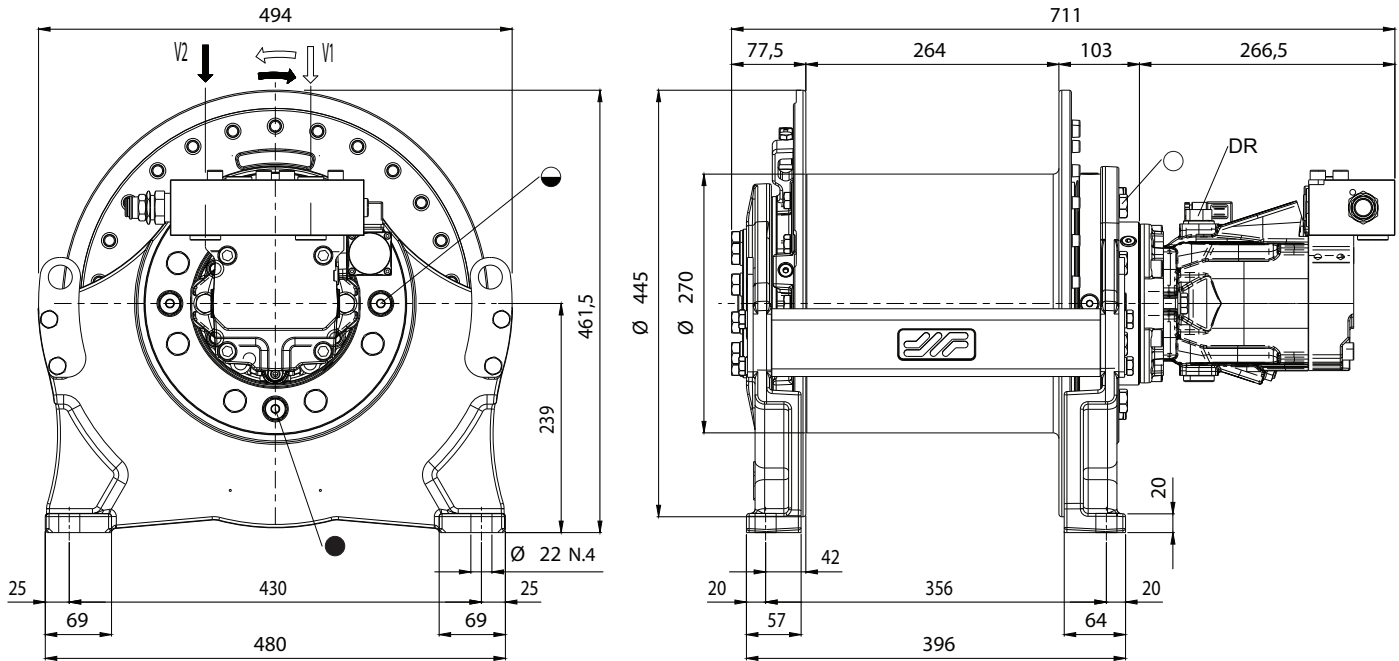
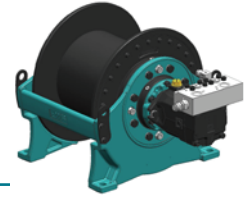

⁽³⁾ ○ Filling plug ● Oil level plug ● Drain plug

Rope layer	n°	1	2	3	4	5 Full drum	6
Line pull	[kg]	5150 / 2550	4600 / 2300	4150 / 2050	3800 / 1900	-(¹)	-
Rope speed with 90 [l/min]	[m/min]	24 / 49	27 / 55	30 / 60	33 / 66	-	-
Rope length	[m]	14	30	47	66	87	-
Starting lifting pressure	205 [bar]	Recommended rope diameter		16 [mm]			
Max. back pressure on return line	5 [bar]	Oil quantity		3 [l]			
Maximum pump delivery	120 [l/min]	Weight		230 [kg]			
Minimum pump delivery	15 [l/min]	Lubrication plug		G3/8 ○ ● ● ⁽³⁾			
Motor displacement	58 / 29 [cm ³ /rev]	Lifting port		G3/4 V2			
Static braking torque	295 [Nm]	Lowering port		G3/4 V1			
Gear ratio	52,78 [i :]	Drain port		G3/4 DR ⁽²⁾			

Winch mechanisms classification in agreement with F.E.M. (1.001) (Third edition revised on 01.10.1998)

$n_2 = 25$ rpm

M4(T4-L2)

Always keep at least 3 wraps of rope on the drum for safety reasons

To fix the winch use screws 8.8 grade

Technical features may change with no previous notice from the manufacturer

THE PRESENT EQUIPMENT MUST NOT BE USED TO LIFT PEOPLE

WHL045-I/3,5

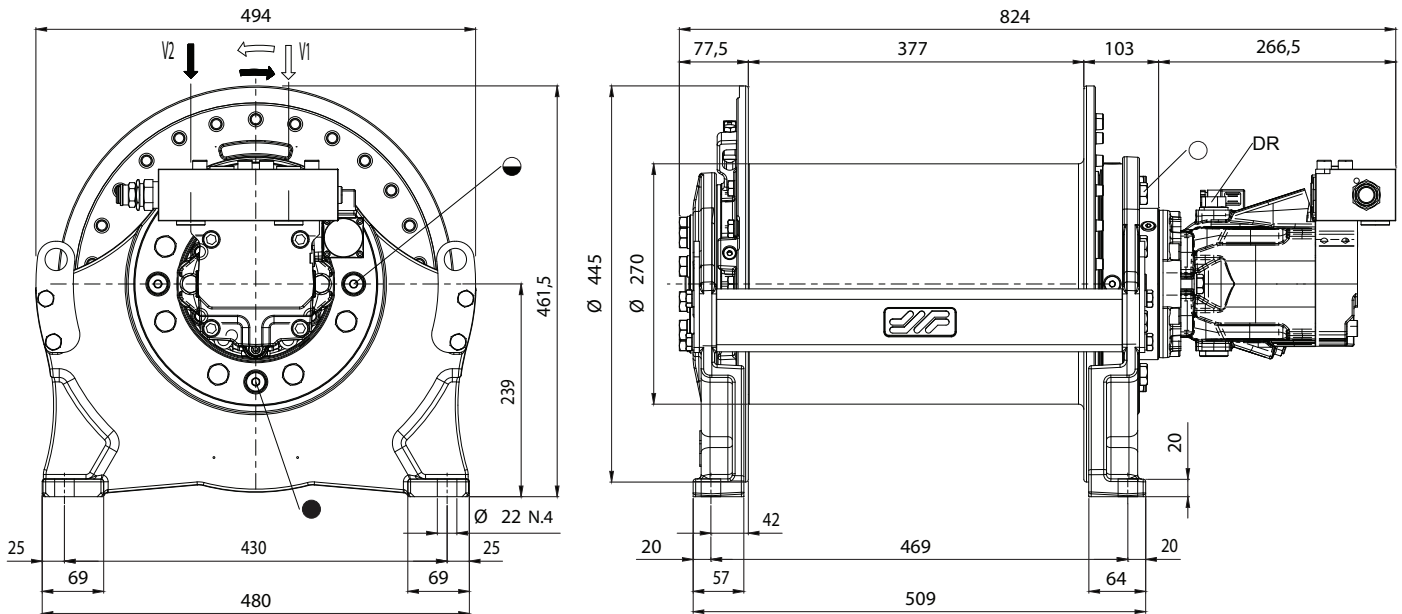
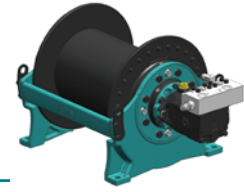

⁽³⁾ ○ Filling plug ● Oil level plug ● Drain plug

Rope layer	n°	1	2	3	4	5 Full drum	6
Line pull	[kg]	5150 / 2550	4600 / 2300	4150 / 2050	3800 / 1900	-(¹)	-
Rope speed with 90 [l/min]	[m/min]	24 / 49	27 / 55	30 / 60	33 / 66	-	-
Rope length	[m]	20	42	67	95	125	-

Starting lifting pressure	205	[bar]	Recommended rope diameter		16	[mm]
Max. back pressure on return line	5	[bar]	Oil quantity		4,5	[l]
Maximum pump delivery	120	[l/min]	Weight		230	[kg]
Minimum pump delivery	15	[l/min]	Lubrication plug		G3/8	○ ● ● ⁽³⁾
Motor displacement	58 / 29	[cm ³ /rev]	Lifting port		G3/4	V2
Static braking torque	295	[Nm]	Lowering port		G3/4	V1
Gear ratio	52,78	[i :]	Drain port		G3/4	DR ⁽²⁾

Winch mechanisms classification in agreement with F.E.M. (1.001) (Third edition revised on 01.10.1998)

$n_2 = 25$ rpm

M4(T4-L2)

Always keep at least 3 wraps of rope on the drum for safety reasons

To fix the winch use screws 8.8 grade

Technical features may change with no previous notice from the manufacturer

THE PRESENT EQUIPMENT MUST NOT BE USED TO LIFT PEOPLE

WHL065-I/4,0

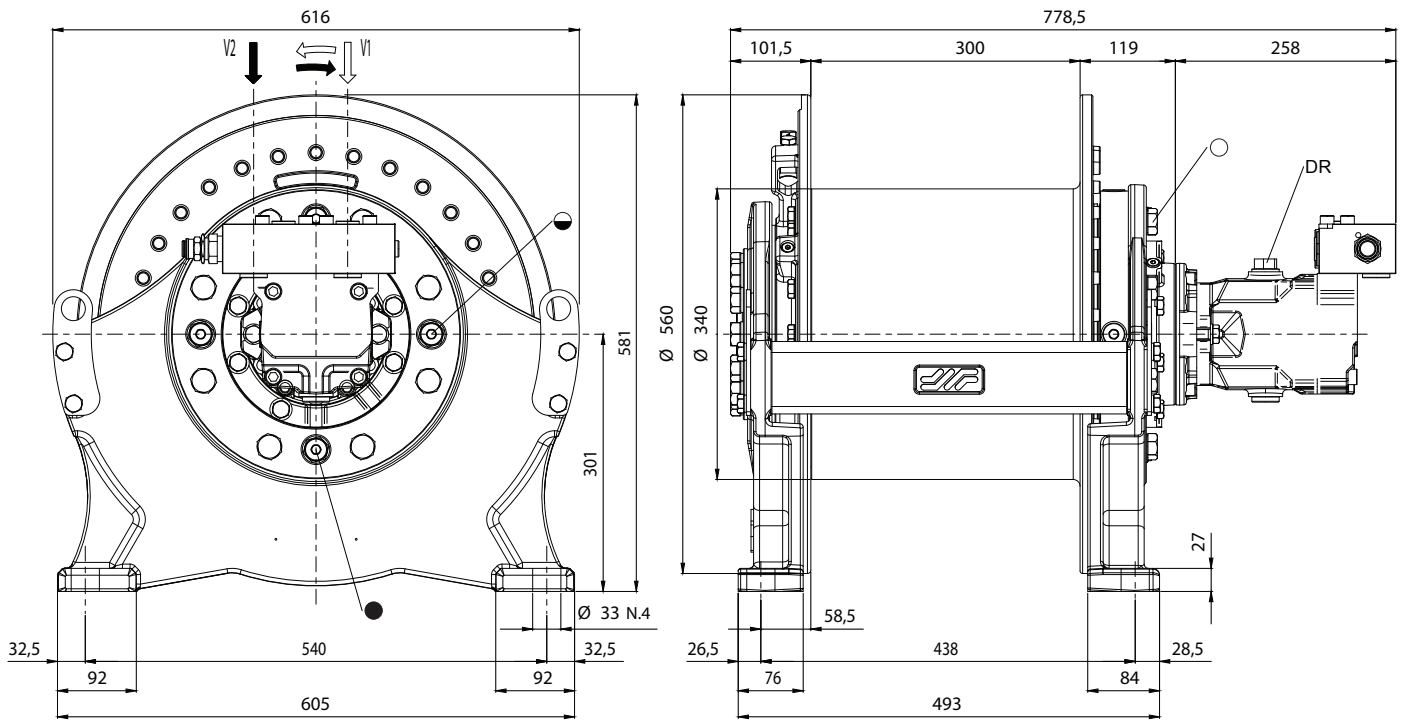
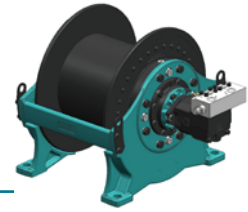

⁽³⁾ ○ Filling plug ● Oil level plug ● Drain plug

Rope layer	n°	1	2	3	4	5 Full drum	6
Line pull	[kg]	5500	4950	4550	4150	-(¹)	-
Rope speed with 100 [l/min]	[m/min]	46	50	55	60	-	-
Rope length	[m]	18	38	60	83	109	-
Starting lifting pressure	350 [bar]	Recommended rope diameter		18 [mm]			
Max. back pressure on return line	5 [bar]	Oil quantity		8 [l]			
Maximum pump delivery	100 [l/min]	Weight		290 [kg]			
Minimum pump delivery	10 [l/min]	Lubrication plug		G1/2 ○ ● ● ⁽³⁾			
Motor displacement	65 [cm ³ /rev]	Lifting port		G3/4 V2			
Static braking torque	571 [Nm]	Lowering port		G3/4 V1			
Gear ratio	35,3 [i :]	Drain port		G3/4 DR ⁽²⁾			

Winch mechanisms classification in agreement with F.E.M. (1.001) (Third edition revised on 01.10.1998)

$n_2 = 25$ rpm

M4(T4-L2)

Always keep at least 3 wraps of rope on the drum for safety reasons

To fix the winch use screws 8.8 grade

Technical features may change with no previous notice from the manufacturer

THE PRESENT EQUIPMENT MUST NOT BE USED TO LIFT PEOPLE

WHL065-I/4,0

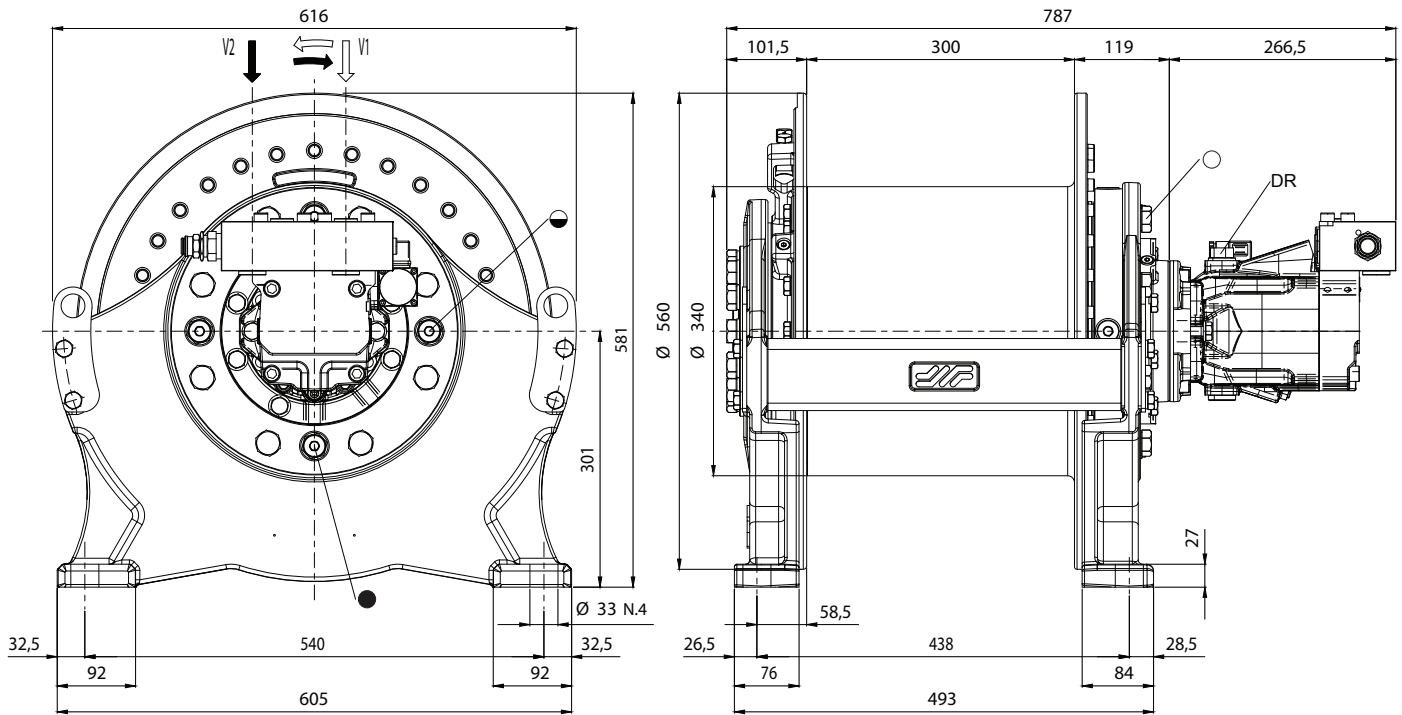
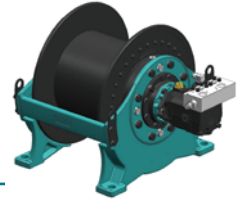

⁽³⁾ ○ Filling plug ● Oil level plug ● Drain plug

Rope layer	n°	1	2	3	4	5 Full drum	6
Line pull	[kg]	5500 / 2700	4950 / 2450	4550 / 2200	4150 / 2050	-(¹)	-
Rope speed with 100 [l/min]	[m/min]	46 / 93	50 / 103	55 / 113	60 / 123	-	-
Rope length	[m]	18	38	60	83	109	-
Starting lifting pressure	350 [bar]	Recommended rope diameter		18 [mm]			
Max. back pressure on return line	5 [bar]	Oil quantity		8 [l]			
Maximum pump delivery	130 [l/min]	Weight		285 [kg]			
Minimum pump delivery	15 [l/min]	Lubrication plug		G1/2 ○ ● ● ⁽³⁾			
Motor displacement	65 / 32 [cm ³ /rev]	Lifting port		G3/4 V2			
Static braking torque	571 [Nm]	Lowering port		G3/4 V1			
Gear ratio	35,3 [i :]	Drain port		G3/4 DR ⁽²⁾			

Winch mechanisms classification in agreement with F.E.M. (1.001) (Third edition revised on 01.10.1998)

$n_2 = 25$ rpm

M4(T4-L2)

Always keep at least 3 wraps of rope on the drum for safety reasons

To fix the winch use screws 8.8 grade

Technical features may change with no previous notice from the manufacturer

THE PRESENT EQUIPMENT MUST NOT BE USED TO LIFT PEOPLE

WHL065-I/6,0

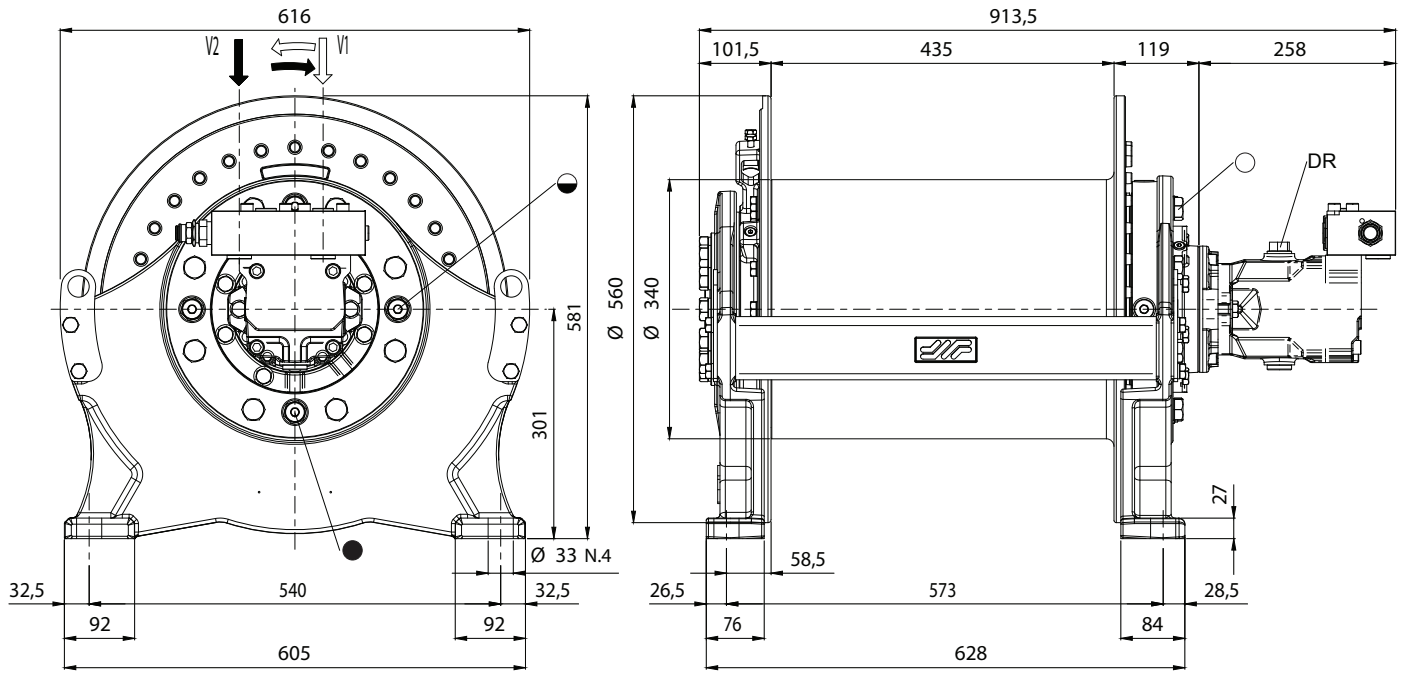
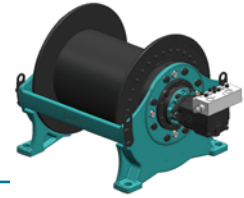

⁽³⁾ ○ Filling plug ● Oil level plug ● Drain plug

Rope layer	n°	1	2	3	4	5 Full drum	6
Line pull	[kg]	8000	7150	6500	6000	-(¹)	-
Rope speed with 150 [l/min]	[m/min]	43	48	53	58	-	-
Rope length	[m]	23	50	79	111	145	-

Starting lifting pressure	330	[bar]	Recommended rope diameter	20	[mm]
Max. back pressure on return line	5	[bar]	Oil quantity	11	[l]
Maximum pump delivery	200	[l/min]	Weight	330	[kg]
Minimum pump delivery	15	[l/min]	Lubrication plug	G1/2	○ ● ● ⁽³⁾
Motor displacement	65	[cm ³ /rev]	Lifting port	G3/4	V2
Static braking torque	570	[Nm]	Lowering port	G3/4	V1
Gear ratio	56,8	[i :]	Drain port	G3/4	DR ⁽²⁾

Winch mechanisms classification in agreement with F.E.M. (1.001) (Third edition revised on 01.10.1998)

$n_2 = 25$ rpm

M4(T4-L2)

Always keep at least 3 wraps of rope on the drum for safety reasons

To fix the winch use screws 8.8 grade

Technical features may change with no previous notice from the manufacturer

THE PRESENT EQUIPMENT MUST NOT BE USED TO LIFT PEOPLE

WHL065-I/6,0

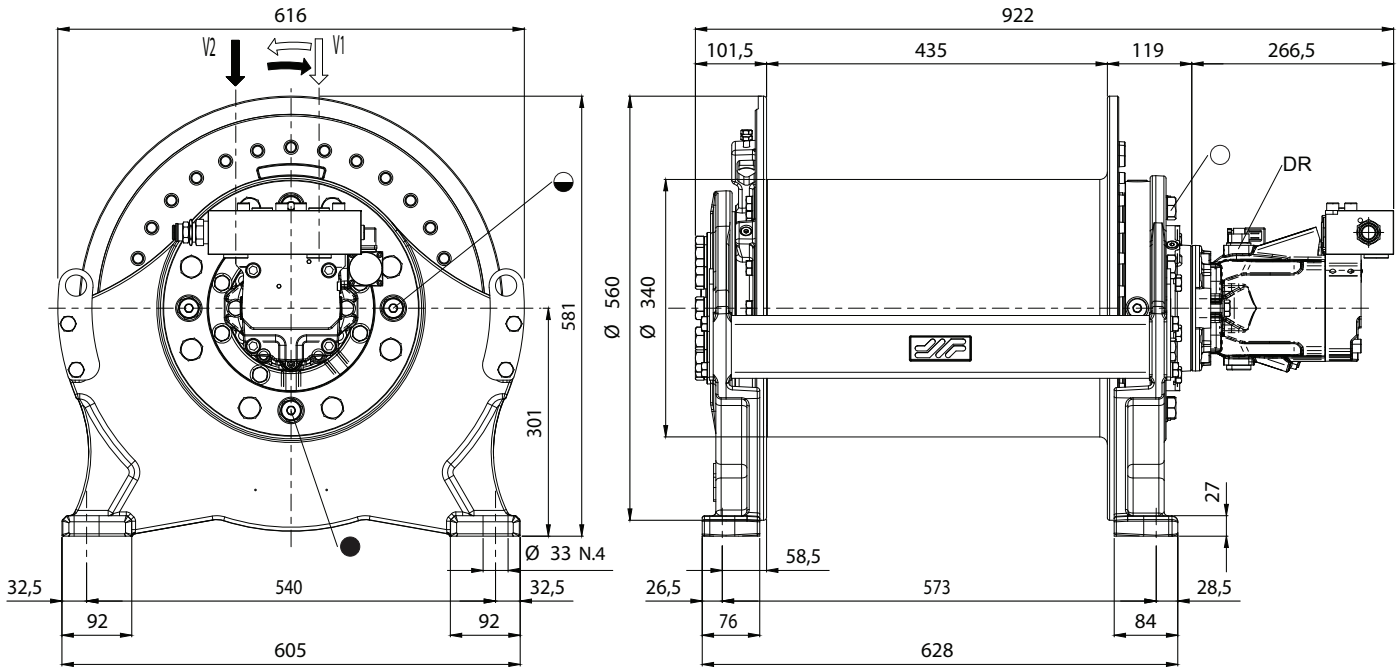
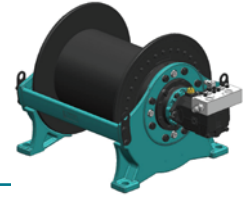

⁽³⁾ ○ Filling plug ● Oil level plug ● Drain plug

Rope layer	n°	1	2	3	4	5 Full drum	6
Line pull	[kg]	8000 / 3900	7150 / 3500	6500 / 3200	6000 / 2900	-(¹)	-
Rope speed with 130 [l/min]	[m/min]	37 / 76	41 / 84	46 / 93	50 / 102	-	-
Rope length	[m]	23	50	79	111	145	-
Starting lifting pressure	330 [bar]	Recommended rope diameter		20 [mm]			
Max. back pressure on return line	5 [bar]	Oil quantity		11 [l]			
Maximum pump delivery	130 [l/min]	Weight		330 [kg]			
Minimum pump delivery	15 [l/min]	Lubrication plug		G1/2 ○ ● ● ⁽³⁾			
Motor displacement	65 / 32 [cm ³ /rev]	Lifting port		G3/4 V2			
Static braking torque	570 [Nm]	Lowering port		G3/4 V1			
Gear ratio	56,8 [i :]	Drain port		G3/4 DR ⁽²⁾			

Winch mechanisms classification in agreement with F.E.M. (1.001) (Third edition revised on 01.10.1998)

$n_2 = 25$ rpm

M4(T4-L2)

Always keep at least 3 wraps of rope on the drum for safety reasons

To fix the winch use screws 8.8 grade

Technical features may change with no previous notice from the manufacturer

THE PRESENT EQUIPMENT MUST NOT BE USED TO LIFT PEOPLE

Input

Universal input E00

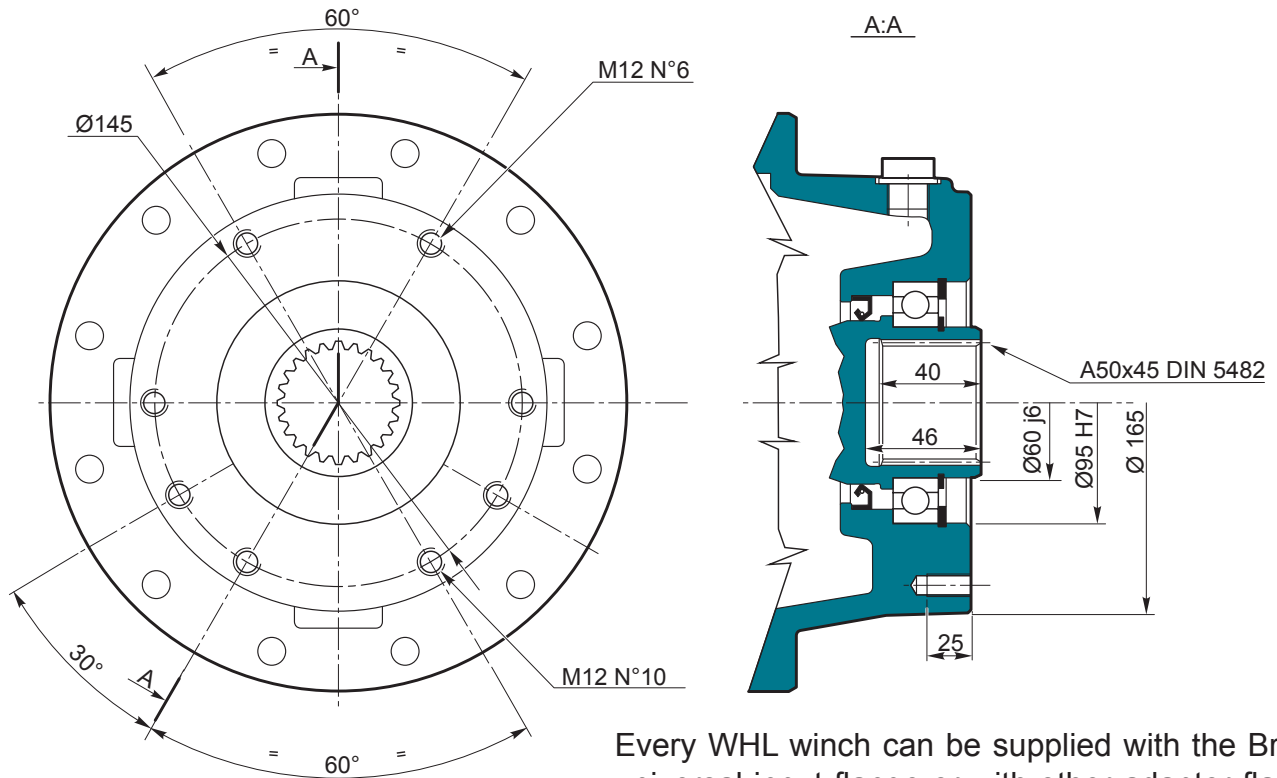

Every WHL winch can be supplied with the Brevini universal input flange or with other adaptor flanges for external motors.

Motor options

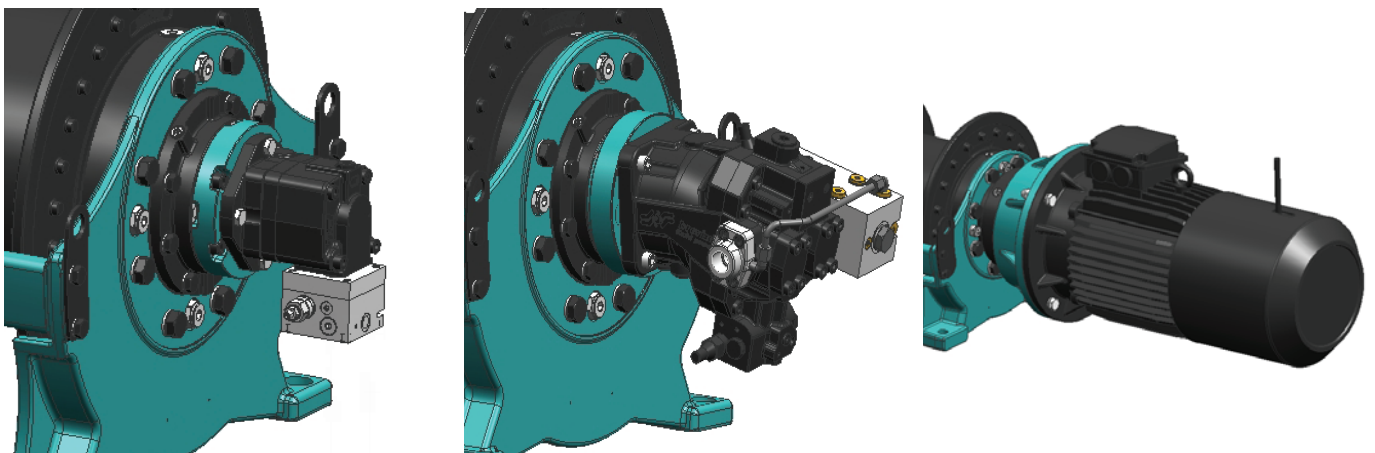

According to the needs of the customer, different motors are available. This means optimizing the performance related to motor displacements and type (orbital or axial piston or electric motor), reduction ratios and hydraulic system characteristics.

Accessories

Grooved drum



All the winches can be supplied not only with our standard grooved drums, but also with other solutions in order to cover customer requests.

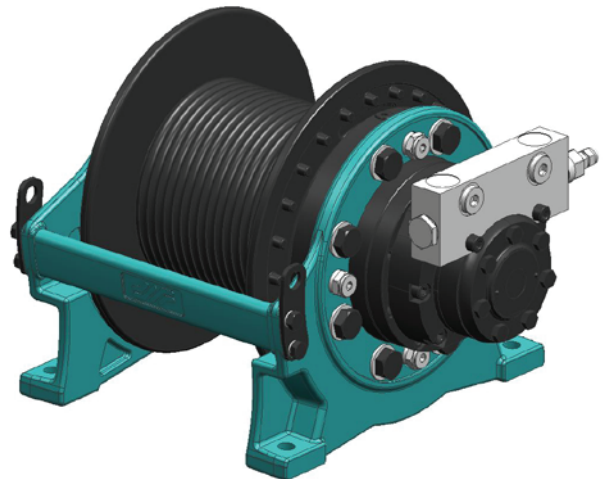

Torque reader sensor



On request, all the WHL winches can be supplied with a strain gauge system which reads the value of the output torque from the drum, according to the existing regulations.

This system has been designed by Brevini Power Transmission in cooperation with BPE Electronics, specialist company (part of the Brevini Group) in the electronic industry.

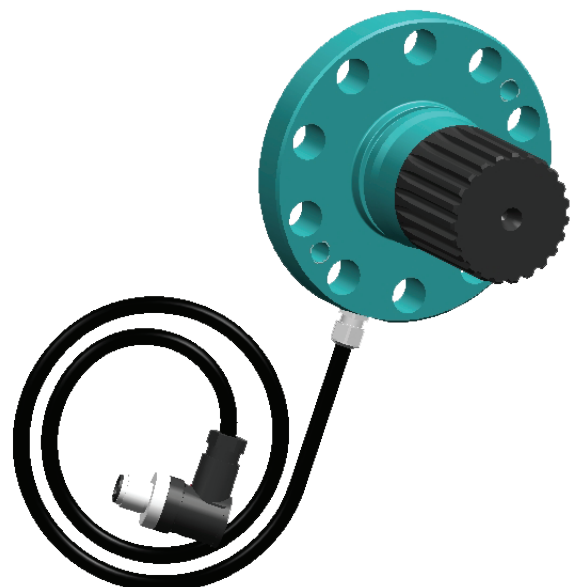

Accessories

Ropes

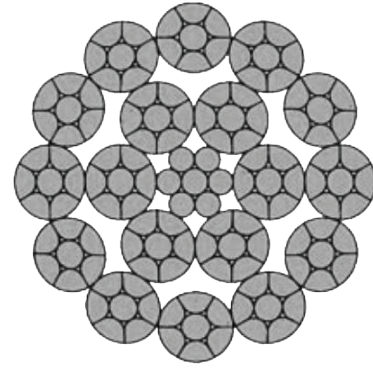
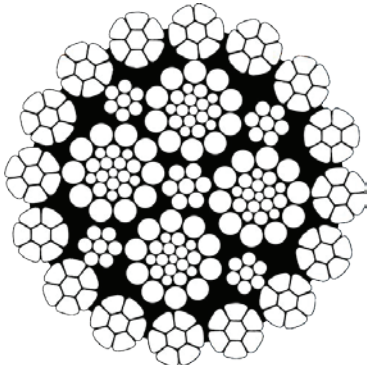
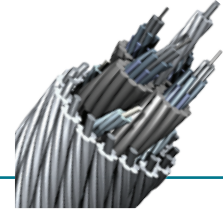

Nominal Diameter [mm]	Minimum Breaking Strength 1960 Grade		Weight/mt [Kg/m]
	[kN]	[t] (M)	
8	55	5,61	0,305
9	69,61	7,1	0,387
10	85,94	8,76	0,477
11	104	10,6	0,577
12	123,8	12,62	0,687
13	145,2	14,81	0,806
14	168,4	17,18	0,935
15	193,4	19,72	1,074
16	220	22,43	1,222
18	278,5	28,39	1,546

Nominal Diameter [mm]	Minimum Breaking Strength		Weight/mt [Kg/m]
	1960 N/mm ² [kN]	200 Kg/mm ² [Kg]	
8	53,3	5.440	0,31
9	67,6	6.890	0,39
10	83,5	8.500	0,48
11	100,9	10.290	0,58
12	120	12.240	0,69
13	141	14.380	0,79
14	163,4	16.660	0,94
15	188	19.170	1,06
16	213,4	21.760	1,22
18	270,1	27.540	1,55

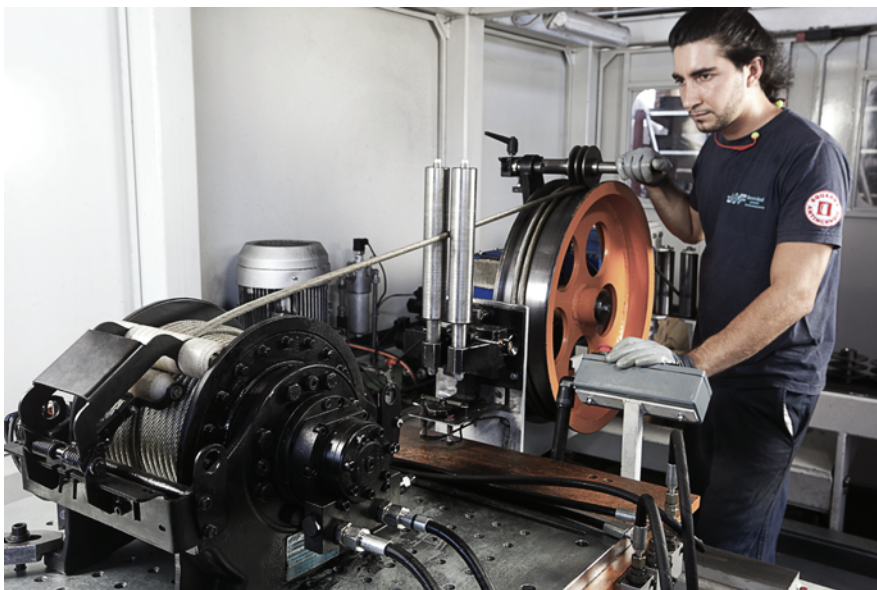

A wide range of high-performance ropes can be installed on all the WHL winches.

The rope winding is made in accordance with the pre-load values in force.

Accessories

Standard Pressure Roller



Use of the standard pressure roller is suggested for an improved rope winding control.

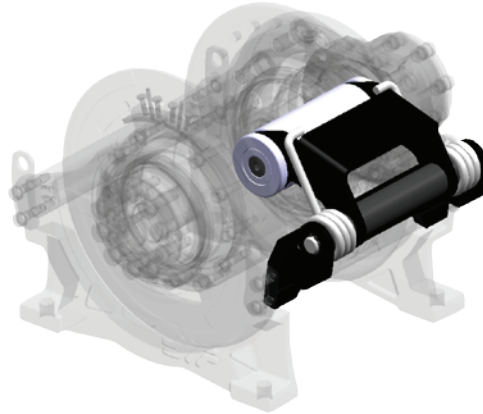

Electric minimum rope controller

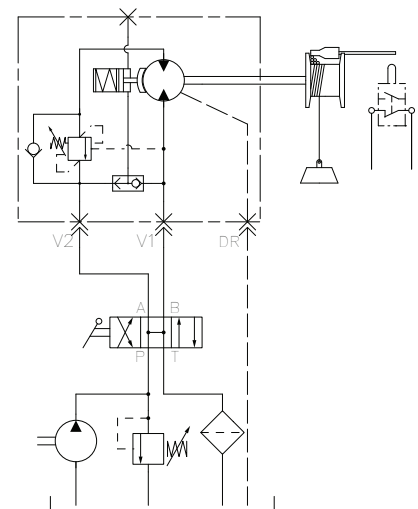
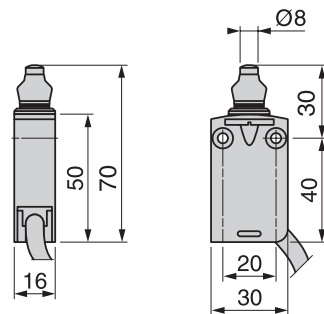
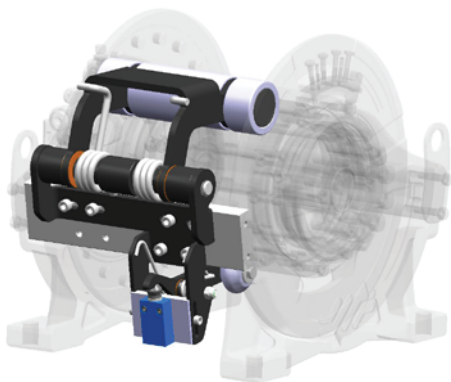

Every minimum rope controller is equipped with a standard pressure roller

Hydraulic minimum rope controller

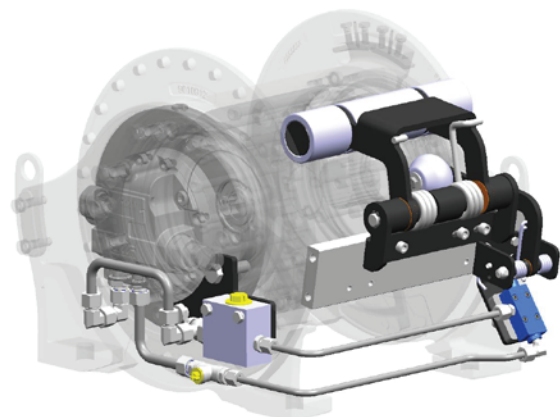
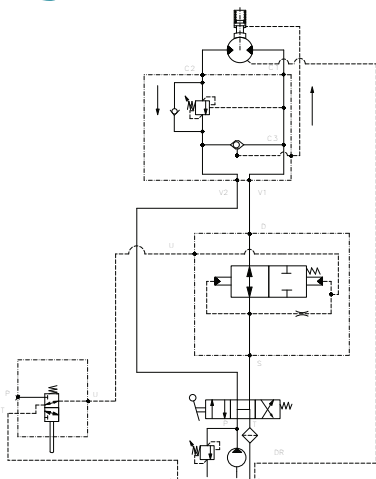

Every minimum rope controller is equipped with a standard pressure roller

For any different solution please contact the Brevini Sales Dept.

Pressure roller position

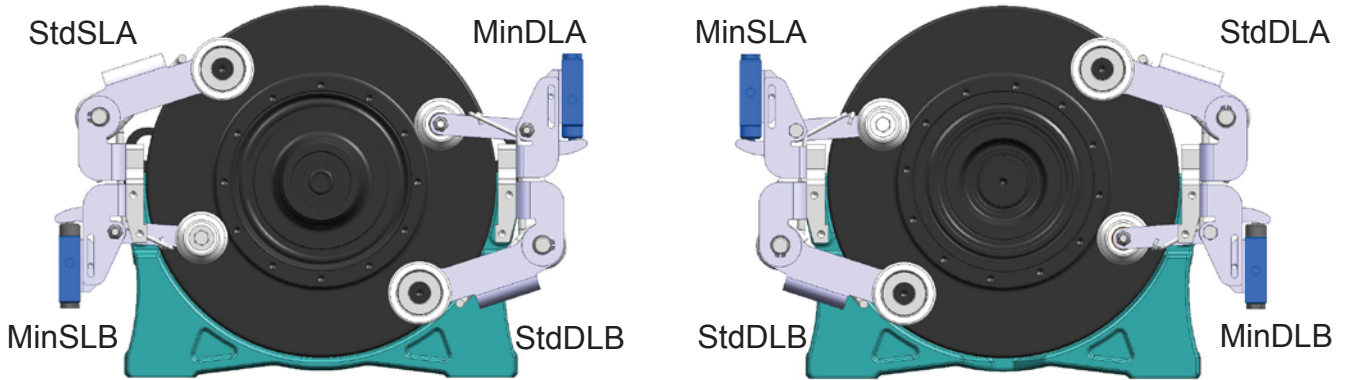
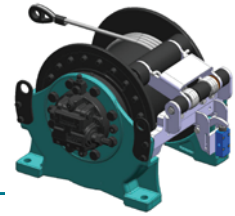

The new and innovative system of pressure roller and rope winding control is highly flexible and ensures continuous pressure on the rope during the winding process. Pressure roller positioning is based on the drum rope exit.

The pictures illustrate the possible assembly combinations, viewed from the motor side.

Full drum (1) only as storage

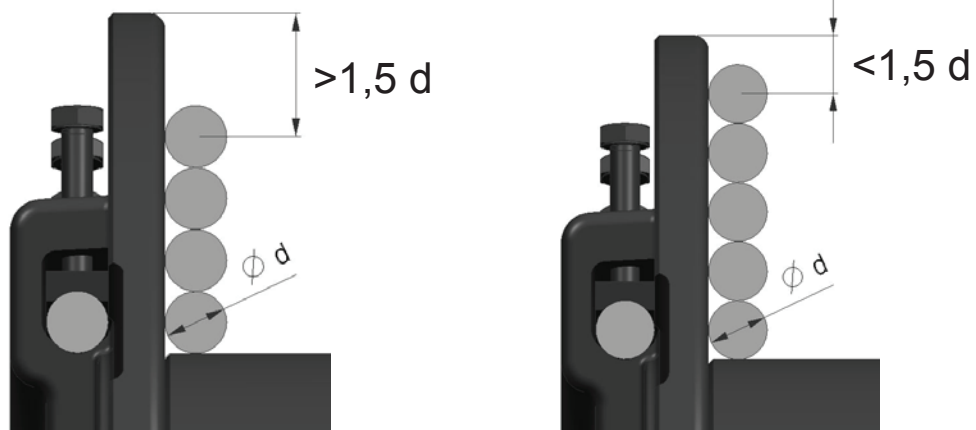
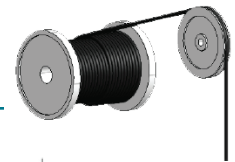



To contain the spill side of the rope, the linear space between the flange end of the drum and the last rope layer must be equal or 1,5 times higher than the nominal rope diameter.

⁽¹⁾The values given in full drum cannot be reached during working conditions, but only during the transport and closing the application.

Accessories

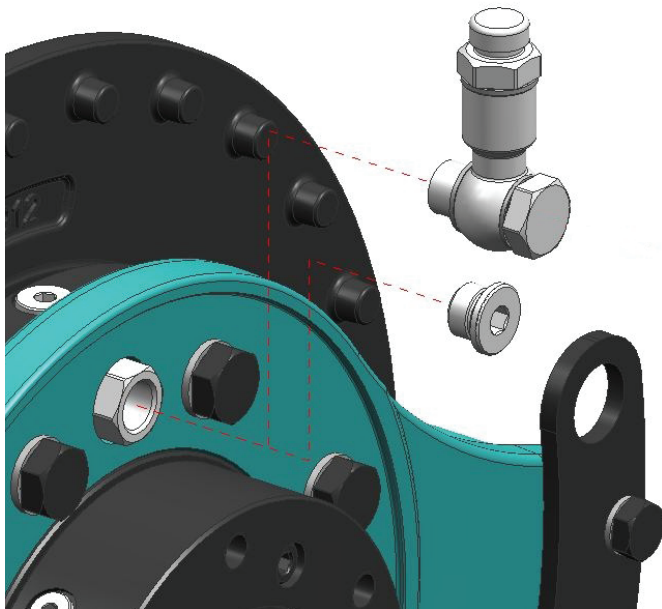
Breather plug



The winches are supplied closed with the right quantity of lubricant oil. Unless otherwise specified, the oil is the synthetic ISO VG 150, provided by SHELL. 

All of this to guarantee the highest quality and reliability and to maintain consistent performance over time, according to the most recent low environmental impact laws. The oil suitable temperature range is from -20°C to 40°C . For other conditions, please contact the Brevini Sales Dept.

In order to avoid oil spills during transport, the winches are supplied without the breather plug. Nevertheless, it can be mounted by the customer, who will be provided with an adequate kit to install the breather in the suitable position for the condition of use of the machine.

Lubrication plugs



(3) Breather and filling

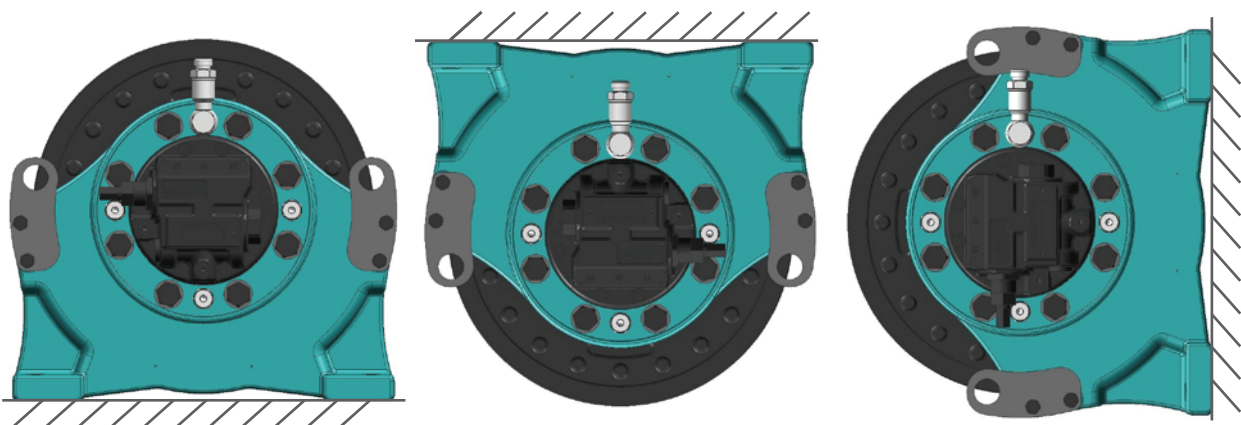

Brevini Power Transmission suggests possibly positioning the breather plug as shown in the highlighted positions, by adapting it to the specific application (customer's machinery).

Hydraulic control system

Recommended solution

Lifting port
V1

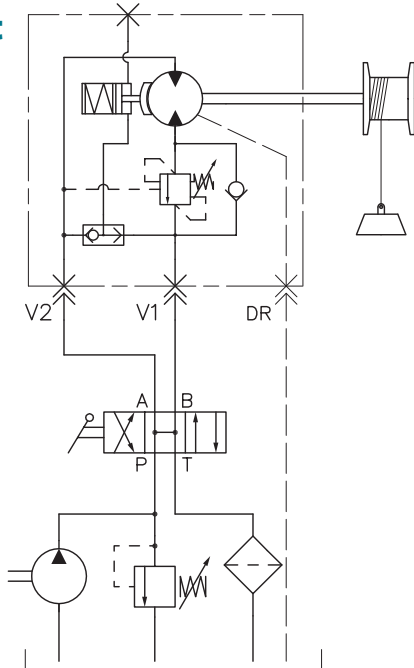

Lifting port
V2

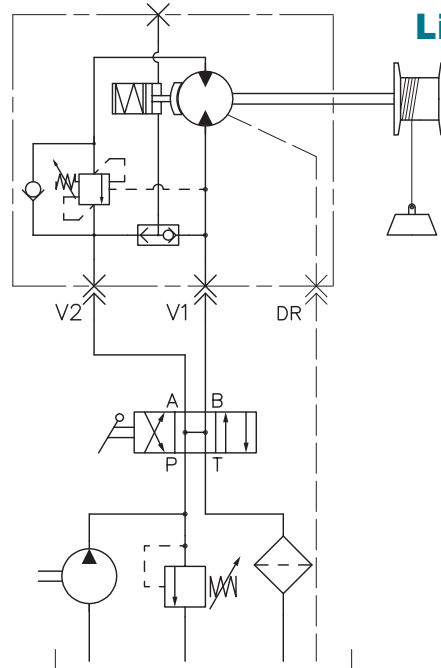

The use of a proper hydraulic oil is recommended as well as a filter not exceeding 10 microns. The drawings illustrate control systems to be purchased by the customer, unless otherwise agreed.

The standard upward rotation is clockwise (01), viewed from motor side.

Drain
(2)

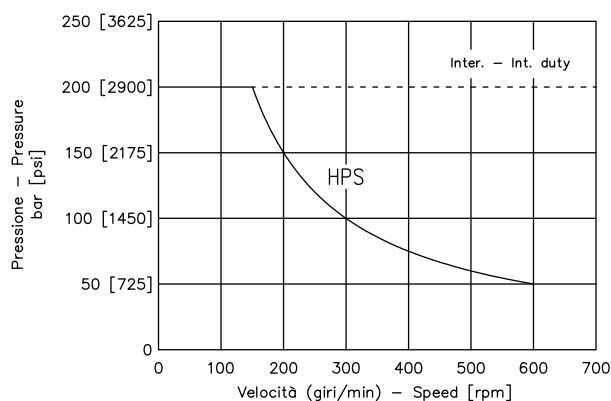

BRZV motors don't feature build-in check valves. The (Ph) pressure on the HPS seal is the average between inlet and outlet pressure. If Ph exceeds rated figures (see graph on side), the drain line must be connected.

$$Ph = \frac{pi + pr}{2} [bar]$$

Ph = housing pressure
pi = inlet pressure
pr = outlet pressure

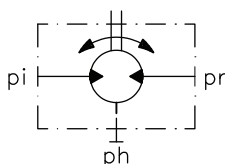

The axial piston hydraulic motor needs a drain port in a high position in order to ensure the presence of the oil in the motor before starting.

Comparative table: Less is more!

Former Series

New WHL Series

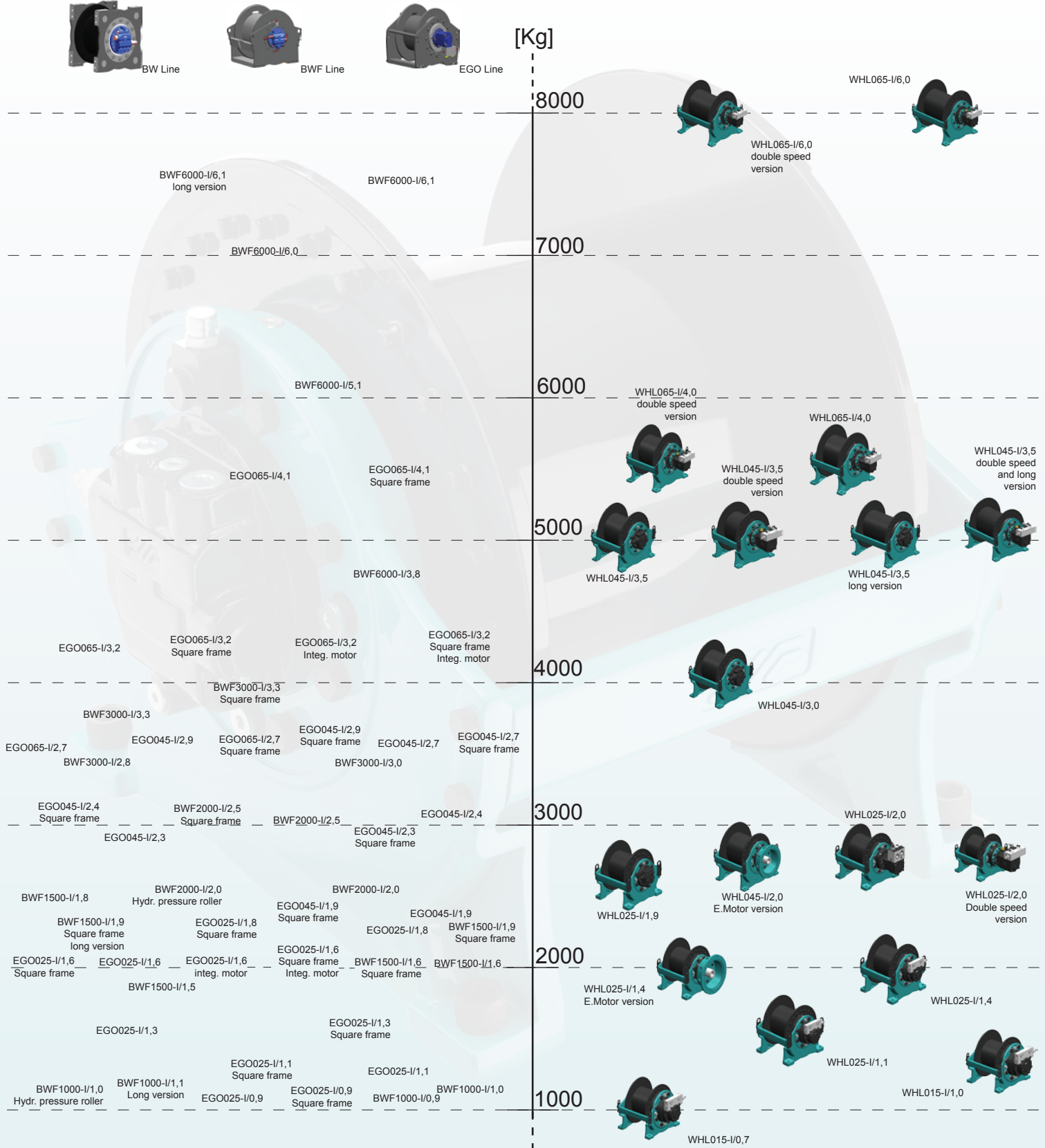

Italy

Brevini Centrosud

00012 - Guidonia Montecelio (Roma) - ITALY
Tel.: +39 - 0774 - 365246
www.brevinicentrosud.it

Piemonte

10143 Torino (TO) – ITALY
Tel.: +39 - 011 7492045
www.brevini.com

Europe

Brevini Austria

A-4300 Gutenhofen - AUSTRIA
Tel.: +43 7435 52823
thomas.zwimer@brevini.com

Brevini España

28350 – Madrid - SPAIN
Tel.: +34 - 91 - 8015165
www.breviniespana.com

Brevini Ireland

Allenwood, Naas, Co. Kildare - IRELAND
Tel.: +353 - 45 - 890100
www.brevini.ie

Brevini Power Transmission Redüktör

Istanbul - Türkiye
Tel. +90 216 540 5909
www.brevini.com

Brevini U.K.

WA1 1QX – Warrington - ENGLAND
Tel.: +44 - 1925 - 636682
www.brevini.co.uk

Overseas

Brevini Australia

Girraween, NSW, 2145 - AUSTRALIA
Tel.: +61 - 2 - 88484000
www.brevini.com.au

Brevini India

400102 – Mumbai - INDIA
Tel.: +91 - 22 - 26794262
www.breviniindia.com

Brevini Latino Americana

13487-220 - Limeira - São Paulo - BRAZIL
Tel.: +55 - 19 - 3446 8600
www.brevini.com.br

Brevini Power Transmission South Africa

1504 - Apex Benoni Johannesburg – SOUTH AFRICA
Tel.: +27 11 421 9949
www.brevinisouthafrica.com

Emilia Romagna and Marche

40012 – Lippo di Calderara di Reno (BO) – ITALY
Tel.: +39 - 051 - 725436
www.brevini.com

Sicilia

91025 Marsala (TP) – ITALY
Tel.: +39 - 0923 - 719721
www.brevini.com

Brevini Benelux

2408 AB - Alphen aan de Rijn - NETHERLANDS
Tel.: +31 - 172 - 476464
www.brevinipowertransmission.nl

Brevini Finland

02270 – Espoo - FINLAND
Tel.: +358-20-743 1828
www.brevini.fi

Brevini Norge

3255 – Larvik - NORWAY
Tel.: +47 - 3311 - 7100
www.brevininorge.no

Brevini Russia

196233 Saint-Petersburg - RUSSIA
tel +7 812 380 2162
www.brevini-russia.ru

Brevini Canada

ON M9W 5R8 – Toronto - CANADA
Tel.: +1 - 416 - 6742591
www.brevini.ca

Brevini Japan

650-0047 – Kobe - JAPAN
Tel.: +81 - 078 - 304 - 5377
www.brevinijapan.com

Brevini De Mexico S.A.

C.P. 76120 Querétaro - MEXICO
Tel.: +52 - 4422 - 100389
www.brevini.com

Brevini South East Asia

608780 SINGAPORE
Tel.: +65 - 6356 - 8922
www.brevini-seasia.com.sg

Lombardia

24050 - Lurano (BG) - ITALY
Tel.: +39 - 035 - 800430
www.brevinilombarda.it

Veneto

45021 - Badia Polesine (RO) - ITALY
Tel.: +39 - 0425 - 53593
www.breviniveneta.it

Brevini Danmark

DK-2690 – Karlslunde - DENMARK
Tel.: +45 - 4615 - 4500
www.brevini.dk

Brevini Power Transmission France

69516 - Vaulx en Velin Cedex - FRANCE
Tel.: +33-04-72-81-25-55
www.brevini-france.fr

Brevini PIV Drives

61352 - Bad Homburg - GERMANY
Tel.: +49 (0)6172 102-0
www.brevini.de

Brevini Svenska

60116 – Norrköping - SWEDEN
Tel.: +46 - 11 - 4009000
www.brevini.se

Brevini China Shanghai Gearboxes

200231 – Shanghai - CHINA
Tel.: +86 - 21 - 64964351/2
www.brevinchina.com

Brevini Korea

1254 – Seoul - KOREA
Tel.: +82 - 2 - 2065 - 9563/4/5
www.brevinikorea.co.kr

Brevini New Zealand

PO Box 58-418 - Greenmount Auckland
NEW ZEALAND
Tel.: +64 - 9 - 2500050
www.brevini.co.nz

Brevini USA

47396 Yorktown, Indiana - U.S.A.
Tel.: +1 - (765) 759-2300
www.breviniusa.com

Distributors



Brevini Power Transmission S.p.A.

Via Luciano Brevini 1
42124 Reggio Emilia - Italy
tel +39 0522 9281
fax +39 0522 928200
info@brevini.com

www.brevini.com



Brevini Power Transmission S.p.A. 42124 Reggio Emilia - Italy -Via Luciano Brevini, 1
T el. +39 0522 9281 - Fax +39 0522 928200 - brevini@brevini.com - www.brevini.com