

AIR-MITE

Pneumatic Arbor Presses & Safety Control Systems

**Building
Affordable
Quality
Precision
Presses
for Over
Half a
Century**

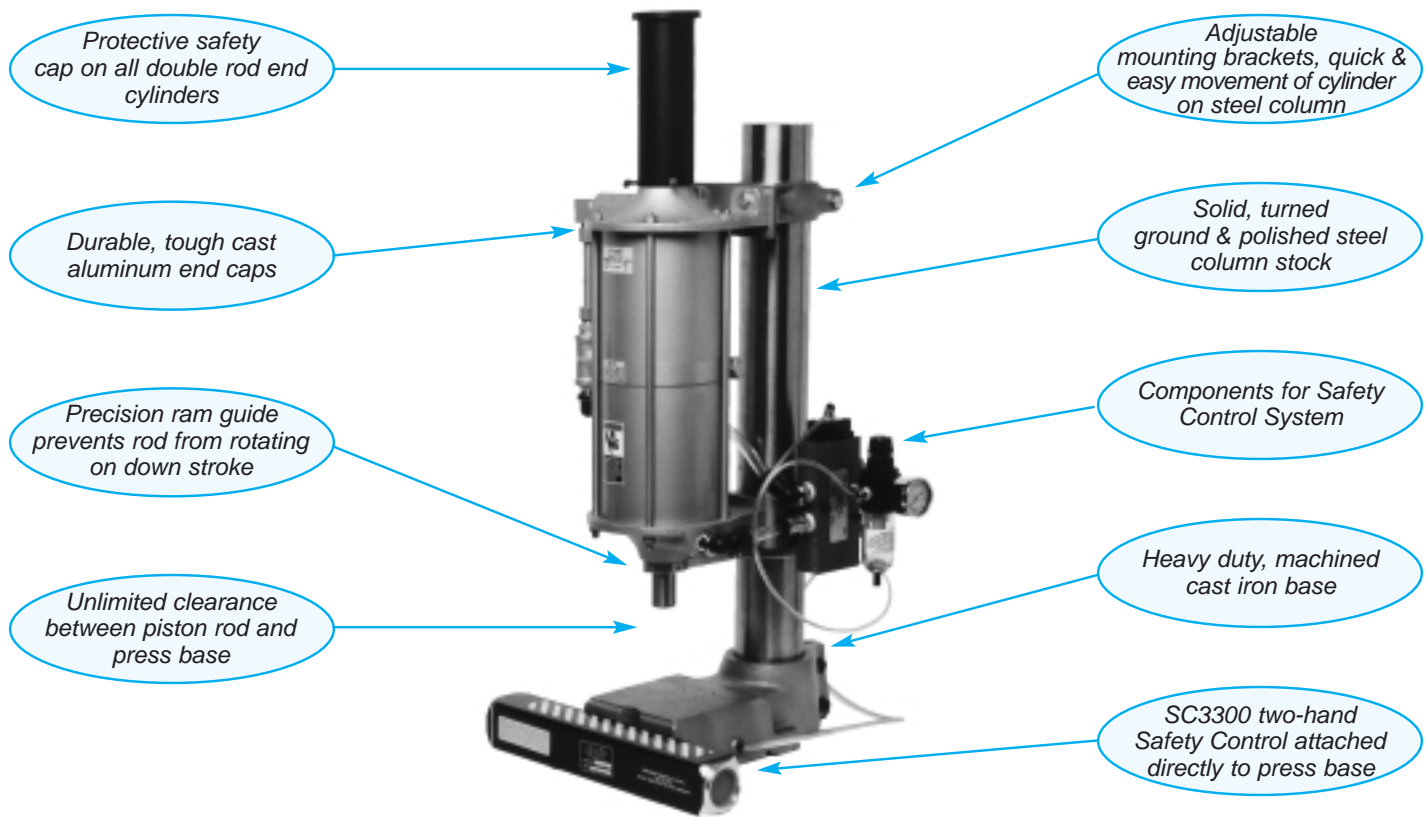



Many reasons why you should purchase an AIR-MITE Press.

Here are answers to most of your questions.

Longevity

For over 50 years, our quality presses have been working in production and assembly areas in industrial plants around the world. Built to be remembered!

Large Selection

Select from 10 models ranging in deliverable force from 1/4 ton to 3 tons. Most complete line anywhere.

Versatility

Our presses are available with single or double rod ends. Fully adjustable up or down to accept all tooling applications. Unlimited clearance between piston rod and press base.

Economical & Affordable

Some of the lowest prices in the industry. Quality combined with economy assures payback in a hurry.

Safety Features & Benefits

Pneumatic or electric safety control systems available for all Air-Mite presses. Two hand safety controls attach directly to the front of the press base. Automated clamp and hold circuits available for all presses.

Rugged, Accurate & Durable

Designed for heavy duty use. Each Air-Mite press has machined cast iron base, a solid-turned, ground and polished steel column and impregnated aluminum end caps. Maintenance free to handle the tough environments.

Press Selection

Applications

- Basic crimping, forming, pressing, stamping, broaching
- Complicated die sets, electronics, medical products

Basic Daylight (Work Area) Distance – All Models

- Standard 6" clearance – from retracted rod to base platen
- Additional daylight area – specify additional when ordering

Stroke & Stroke Adjustment

- Standard – as shown, Additional – as required
- DR (Double Rod) Models – top rod threaded UNF with rod nuts provided
- Lower rod threaded – additional charge

Rod End Options (see chart below)

- Type 1 – Blank (plain) rod end
- Type 2 – Full thread – Male UNF or UNC
- Type 3 – Reduced diameter male UNF or UNC thread
- Type 4 – Female UNF thread
- Type 5 – Per customer requirement

Standard Rod Extension

Models 4, 7, 12, 19 – 1.5"

Models 24, 38, 58 – 2"

Longer extensions available

Ram Guides

Standard on DAP38, DAP38DR and DAP58DR models – for applications requiring non-rotating rod during press cycling.

- Type A – Yoke design attaching rod to OD of press column – standard guide
- Type B – Keywayed into steel or chromed column

Operating Pressures

- Minimum Pressures – 25-30 psi
- Maximum Pressure – 120 psi

Safety Controls

Controls specifically designed for all presses – two hand non-tie down controls.

- Stand alone – Self-contained or modular designs
- Press ready – Specifically designed for presses – a complete system ready to install

Power Conversion Table

Air-Mite presses are built to provide the maximum in holding power. However, some applications require a regulated inlet pressure. This table is furnished as a quick reference to provide the force delivered in pounds by all Air-Mite presses. To determine the desired amount of force for your application, refer to model number & diameter of press selected and read across at the various line pressures.

Press Model Number	Cylinder Diameter in Inches	Power Factor & Bore in Sq. Inches	Line Pressure Power Conversion Table (Force in lbs.)							
			50 psi	60 psi	70 psi	80 psi	90 psi	100 psi	110 psi	120 psi
4	2.25	3.98	199	229	278	318	358	398	438	477
7	3	7.07	353	424	494	565	635	707	777	847
12	4	12.56	628	754	879	1005	1130	1256	1382	1507
14	3	14.14	706	848	988	1130	1270	1414	1554	1694
19	5	19.63	982	1178	1374	1571	1767	1963	2159	2356
24	4	25.12	1256	1508	1758	2010	2260	2512	2764	3014
38	5	39.26	1964	2356	2748	3142	3534	3926	4318	4712
58	5	58.89	2946	3534	4122	4713	5301	5889	6477	7068

Suggested Rod End Styles

Identify the appropriate model number, rod diameter & thread type for your press. When ordering, add the corresponding Type-1,2,3,4-after stroke length to receive desired rod end option. Threads noted are suggested sizes. We can furnish other thread sizes upon request.

Note: To order wrench flats on rod ends, simply add WF after thread type.

Suggested Rod End Options				
Press Model Nos.	Rod Diameter	Full Thread UNF	Reduced Thread	Female Thread
	Type 1	Type 2	Type 3	Type 4
4, 7, 14	1/2	1/2-20	7/16-20	1/4-28
12, 24	3/4	3/4-16	1/2-20	3/8-24
19, 38, 58	1	1-14	3/4-16	1/2-20

Spring Return Shorter Stroke 1/4, 1/2, 3/4 & 1 Ton Models

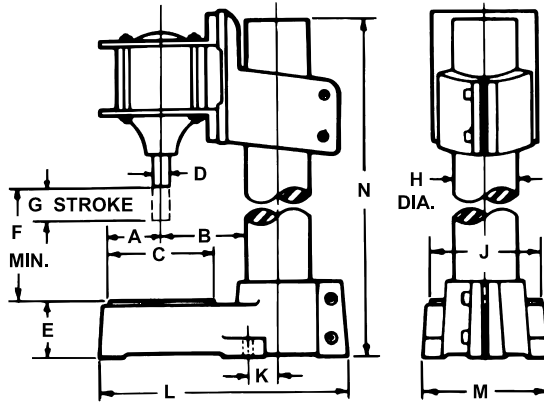

SINGLE ACTING-SPRING RETURN

Model No.	Bore Size	Stroke	Power Factor	A	B	C	D	E	F	G	H	J	K	L	M	N	Pipe Size	Net Weight
AP4	2 1/4"	1 1/2"	3.98	1 7/8"	4"	4"	1/2"	2 1/8"	6"	1 1/2"	2 3/8"	4"	1 3/4"	10 1/8"	4 11/16"	12 3/4"	1/4 NPT	40
AP7	3"	1 1/2"	7.07	1 3/4"	4 3/8"	4"	1/2"	2 1/8"	6"	1 1/2"	2 3/8"	4"	1 3/4"	10 1/8"	4 11/16"	12 3/4"	1/4 NPT	41
AP12	4"	2"	12.56	2 1/2"	4 1/8"	5"	3/4"	2 9/16"	6"	2"	3"	5"	1 7/16"	11 7/8"	5 7/8"	14 1/2"	3/8 NPT	71
AP19	5"	2"	19.63	1 7/8"	4 11/16"	5"	1"	2 9/16"	6"	2"	3"	5"	1 7/16"	11 7/8"	5 7/8"	14 1/2"	1/2 NPT	73

Spring Return Shorter Stroke Double Rod End 1/4, 1/2, 3/4 & 1 Ton Models

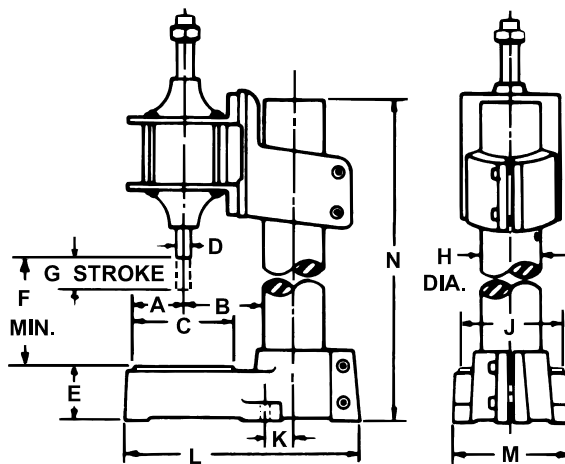

SINGLE ACTING-SPRING RETURN

Model No.	Bore Size	Stroke	Power Factor	A	B	C	D	E	F	G*	H	J	K	L	M	N*	Pipe Size	Net Weight
AP4DR	2 1/4"	1 1/2"	3.98	1 5/8"	4"	4"	1/2"	2 1/8"	6"	1 1/2"	2 3/8"	4"	1 3/4"	10 1/8"	4 11/16"	12 3/4"	1/4 NPT	40
AP7DR	3"	1 1/2"	7.07	1 1/2"	4 3/8"	4"	1/2"	2 1/8"	6"	1 1/2"	2 3/8"	4"	1 3/4"	10 1/8"	4 11/16"	12 3/4"	1/4 NPT	41
AP12DR	4"	2"	12.56	2 1/2"	4 1/8"	5"	3/4"	2 9/16"	6"	2"	3"	5"	1 7/16"	11 7/8"	5 7/8"	14 1/2"	3/8 NPT	73
AP19DR	5"	2"	19.63	1 7/8"	4 11/16"	5"	1"	2 9/16"	6"	2"	3"	5"	1 7/16"	11 7/8"	5 7/8"	14 1/2"	1/2 NPT	75

*Longer stroke available on request. *Longer column available on request.

Spring Return Models

Spring Return Longer Stroke 1/4, 1/2, 3/4 & 1 Ton Models

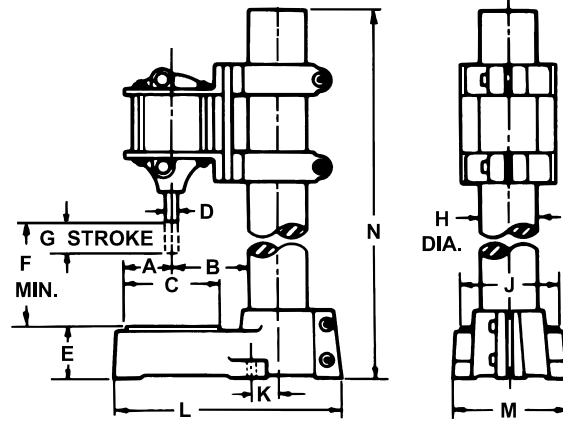

SINGLE ACTING-SPRING RETURN

Model No.	Bore Size	Stroke	Power Factor	A	B	C	D	E	F	G*	H	J	K	L	M	N*	Pipe Size	Weight
AP4	2 1/4"	2"	3.98	1 7/8"	3 3/4"	4"	1/2"	2 1/8"	6"	2"	2 3/8"	4"	1 3/4"	10 1/8"	4 11/16"	15 3/4"	1/4 NPT	41
AP7	3"	2"	7.07	1 3/4"	4 1/8"	4"	1/2"	2 1/8"	6"	2"	2 3/8"	4"	1 3/4"	10 1/8"	4 11/16"	15 3/4"	1/4 NPT	43
AP12	4"	3"	12.56	2 1/2"	4"	5"	3/4"	2 9/16"	6"	3"	3"	5"	1 7/16"	11 7/8"	5 7/8"	18 1/2"	3/8 NPT	74
AP19	5"	3"	19.63	1 7/8"	4 1/2"	5"	1"	2 9/16"	6"	3"	3"	5"	1 7/16"	11 7/8"	5 7/8"	18 1/2"	1/2 NPT	76

*Longer stroke available on request. *Longer column available on request.

Spring Return Longer Stroke Double Rod End 1/4, 1/2, 3/4 & 1 Ton Models

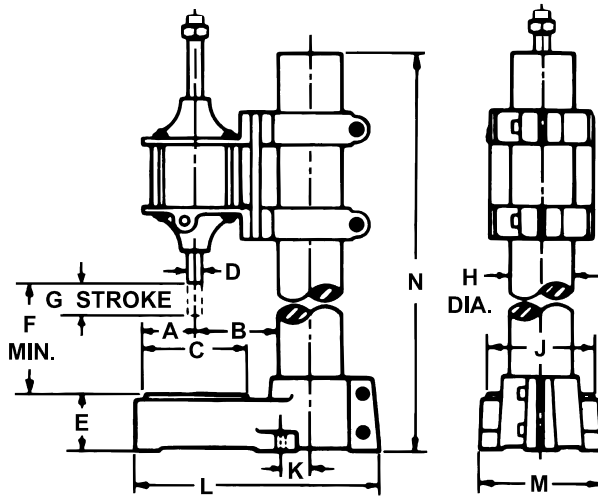

SINGLE ACTING-SPRING RETURN

Model No.	Bore Size	Stroke	Power Factor	A	B	C	D	E	F	G*	H	J	K	L	M	N*	Pipe Size	Net Weight
AP4DR	2 1/4"	2"	3.98	1 7/8"	3 3/4"	4"	1/2"	2 1/8"	6"	2"	2 3/8"	4"	1 3/4"	10 1/8"	4 11/16"	15 3/4"	1/4 NPT	41
AP7DR	3"	2"	7.07	1 3/4"	4 1/8"	4"	1/2"	2 1/8"	6"	2"	2 3/8"	4"	1 3/4"	10 1/8"	4 11/16"	15 3/4"	1/4 NPT	43
AP12DR	4"	3"	12.56	2 1/2"	4"	5"	3/4"	2 9/16"	6"	3"	3"	5"	1 7/16"	11 7/8"	5 7/8"	18 1/2"	3/8 NPT	75
AP19DR	5"	3"	19.63	1 7/8"	4 1/2"	5"	1"	2 9/16"	6"	3"	3"	5"	1 7/16"	11 7/8"	5 7/8"	18 1/2"	1/2 NPT	77

*Longer stroke available on request. *Longer column available on request.

Double Acting Shorter Stroke 1/4, 1/2, 3/4 & 1 Ton Models

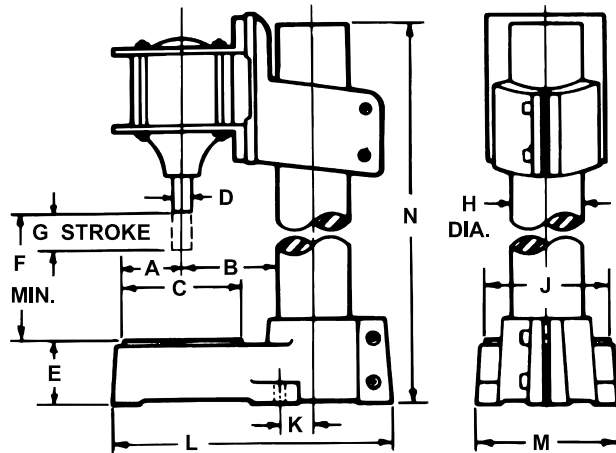

DOUBLE ACTING-AIR RETURN

Model No.	Bore Size	Stroke	Power Factor	A	B	C	D	E	F	G	H	J	K	L	M	N*	Pipe Size	Net Weight
DAP4	2 1/4"	1"	3.98	1 7/8"	4"	4"	1/2"	2 1/8"	6"	1"	2 3/8"	4"	1 3/4"	10 1/8"	4 11/16"	12 3/4"	1/4 NPT	40
DAP7	3"	1"	7.07	1 1/2"	4 3/8"	4"	1/2"	2 1/8"	6"	1"	2 3/8"	4"	1 3/4"	10 1/8"	4 11/16"	12 3/4"	1/4 NPT	41
DAP12	4"	1 1/2"	12.56	2 1/2"	4 1/8"	5"	3/4"	2 9/16"	6"	1 1/2"	3"	5"	1 7/16"	11 7/8"	5 7/8"	14 1/2"	3/8 NPT	71
DAP19	5"	1 1/2"	19.63	1 7/8"	4 11/16"	5"	1"	2 9/16"	6"	1 1/2"	3"	5"	1 7/16"	11 7/8"	5 7/8"	14 1/2"	1/2 NPT	73

*Column length optional. Ram guides optional. "K" Dimension figures are approximate

Double Acting Shorter Stroke Double Rod End 1/4, 1/2, 3/4 & 1 Ton Models

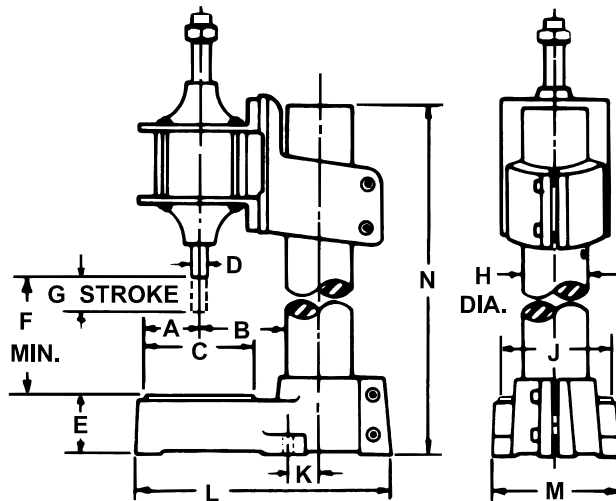

DOUBLE ACTING-AIR RETURN

Model No.	Bore Size	Stroke	Power Factor	A	B	C	D	E	F	G	H	J	K	L	M	N*	Pipe Size	Weight
DAP4DR	2 1/4"	1"	3.98	1 7/8"	4"	4"	1/2"	2 1/8"	6"	1"	2 3/8"	4"	1 3/4"	10 1/8"	4 11/16"	12 3/4"	1/4 NPT	40
DAP7DR	3"	1"	7.07	1 1/2"	4 3/8"	4"	1/2"	2 1/8"	6"	1"	2 3/8"	4"	1 3/4"	10 1/8"	4 11/16"	12 3/4"	1/4 NPT	41
DAP12DR	4"	1 1/2"	12.56	2 1/2"	4 1/8"	5"	3/4"	2 9/16"	6"	1 1/2"	3"	5"	1 7/16"	11 7/8"	5 7/8"	14 1/2"	3/8 NPT	73
DAP19DR	5"	1 1/2"	19.63	1 3/4"	4 11/16"	5"	1"	2 9/16"	6"	1 1/2"	3"	5"	1 7/16"	11 7/8"	5 7/8"	14 1/2"	1/2 NPT	75

*Column length optional. Ram guides optional. "K" Dimension figures are approximate

Double Acting Models

Double Acting Longer Stroke 1/4, 1/2, 3/4 & 1 Ton Models

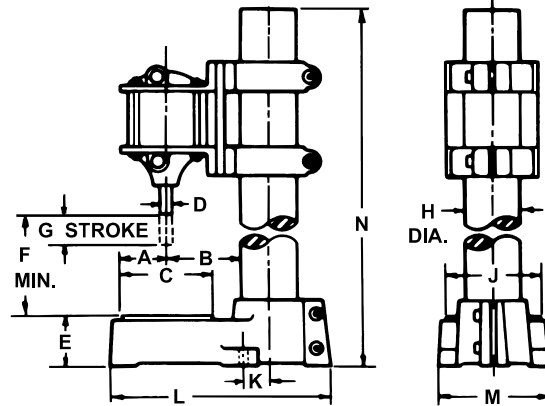

DOUBLE ACTING-AIR RETURN

Model No.	Bore Size	Stroke	Power Factor	A	B	C	D	E	F	G*	H	J	K	L	M	N*	Pipe Size	Weight
DAP4	2 1/4"	1 1/2"	3.98	1 7/8"	3 3/4"	4"	1/2"	2 1/8"	6"	1 1/2"	2 3/8"	4"	1 3/4"	10 1/8"	4 11/16"	15 1/4"	1/4 NPT	40
DAP7	3"	1 1/2"	7.07	1 1/2"	4 1/8"	4"	1/2"	2 1/8"	6"	1 1/2"	2 3/8"	4"	1 3/4"	10 1/8"	4 11/16"	15 1/4"	1/4 NPT	41
DAP12	4"	2"	12.56	2 1/2"	4"	5"	3/4"	2 9/16"	6"	2"	3"	5"	1 7/16"	11 7/8"	5 7/8"	17 1/2"	3/8 NPT	71
DAP19	5"	2"	19.63	1 7/8"	4 1/2"	5"	1"	2 9/16"	6"	2"	3"	5"	1 7/16"	11 7/8"	5 7/8"	17 1/2"	1/2 NPT	72

*Column length optional. *Stroke length optional. Ram guides optional. "K" Dimension figures are approximate

Double Acting Longer Stroke Double Rod End 1/4, 1/2, 3/4 & 1 Ton Models

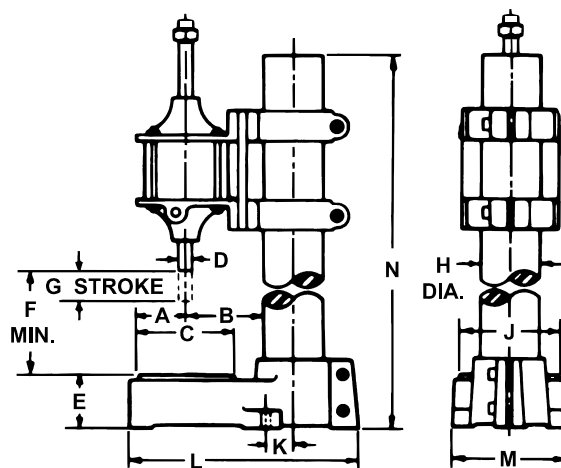

DOUBLE ACTING-AIR RETURN

Model No.	Bore Size	Stroke	Power Factor	A	B	C	D	E	F	G*	H	J	K	L	M	N*	Pipe Size	Net Weight
DAP4DR	2 1/4"	1 1/2"	3.98	1 7/8"	3 3/4"	4"	1/2"	2 1/8"	6"	1 1/2"	2 3/8"	4"	1 3/4"	10 1/8"	4 11/16"	15 1/4"	1/4 NPT	41
DAP7DR	3"	1 1/2"	7.07	1 1/2"	4 1/8"	4"	1/2"	2 1/8"	6"	1 1/2"	2 3/8"	4"	1 3/4"	10 1/8"	4 11/16"	15 1/4"	1/4 NPT	42
DAP12DR	4"	2"	12.56	2 1/2"	4"	5"	3/4"	2 9/16"	6"	2"	3"	5"	1 7/16"	11 7/8"	5 7/8"	17 1/2"	3/8 NPT	73
DAP19DR	5"	2"	19.63	1 7/8"	4 1/2"	5"	1"	2 9/16"	6"	2"	3"	5"	1 7/16"	11 7/8"	5 7/8"	17 1/2"	1/2 NPT	76

*Longer stroke available on request. *Longer column available on request. Ram guides optional.

Tandem Press Double Acting 3/4, 1 1/4 & 2 Ton Models

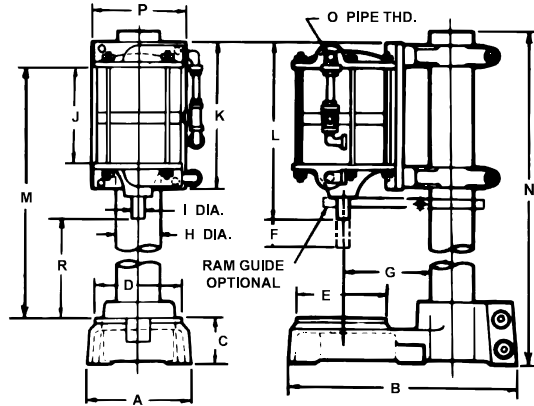

DOUBLE ACTING-AIR RETURN

Model	Bore Size	Power Capacity	Power Factor	A	B	C	D	E	F*	G	H	I	J	K	L	M	N*	O	P	R	Pipe Size	Weight
DAP14	3"	3/4Ton	14.14	4 11/16"	10 1/8"	2 1/8"	4"	4"	2"	4 1/8"	2 3/8"	1/2"	6 5/16"	8 13/16"	12 1/8"	16 3/8"	19 1/2"	1/4"	4"	6"	1/4"	52
DAP24	4"	1 1/4 Ton	25.12	5 7/8"	11 7/8"	2 9/16"	5 1/16"	5 1/16"	2"	4"	3"	3/4"	7 3/4"	10 1/8"	13 1/8"	17 3/4"	21 1/2"	3/8"	5 1/2"	6"	3/8"	90
DAP38	5"	2 Ton	39.26	5 7/8"	11 7/8"	2 9/16"	5 1/16"	5 1/16"	2"	4 1/2"	3"	1"	7 9/16"	10 3/4"	13"	19"	21 1/2"	1/2"	6 1/4"	6"	1/2"	97

*Longer stroke available on request. *Longer column available on request.

Tandem Press Double Acting Double Rod 3/4, 1 1/4 & 2 Ton Models

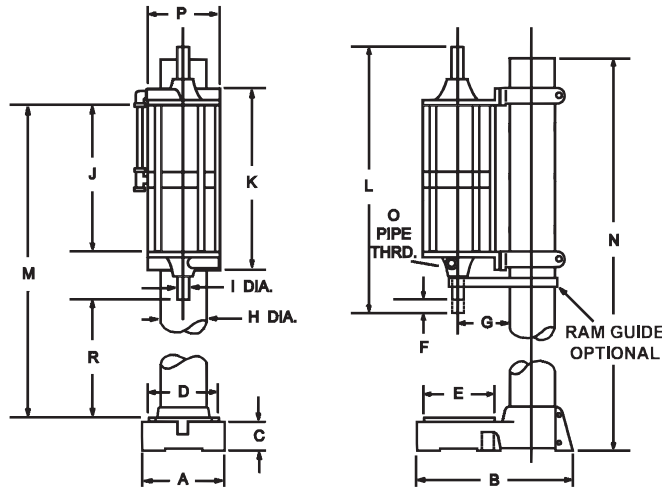

DOUBLE ACTING-DOUBLE ROD

Model	Bore Size	Power Capacity	Factor	A	B	C	D	E	F*	G	H	I	J	K	L	M	NN	O	P	R	Pipe Size	Weight
DAP14DR	3"	3/4 Ton	14-1	4 11/16"	10 1/8"	2 1/8"	4"	4"	2"	4 1/8"	2 3/8"	1/2"	7"	8 13/16"	14 1/4"	16 3/8"	19 1/2"	1/4"	4"	6"	1/4 NPT	54
DAP24DR	4"	1 1/4 Ton	25-1	5 7/8"	11 7/8"	2 9/16"	5 1/16"	5 1/16"	2"	4"	3"	3/4"	7 1/2"	10 1/8"	17 1/8"	17 7/16"	21 1/2"	3/8"	5 1/2"	6"	3/8 NPT	93
DAP38DR	5"	2 Ton	39-1	5 7/8"	11 7/8"	2 9/16"	5 1/16"	5 1/16"	2"	4 9/16"	3"	1"	7 1/2"	10 3/4"	17 1/4"	19"	21 1/2"	1/2"	6 1/4"	6"	1/2 NPT	100

*Longer stroke available on request. *Longer column available on request.

Triplex Models

Triplex Press Double Acting 3 Ton Model

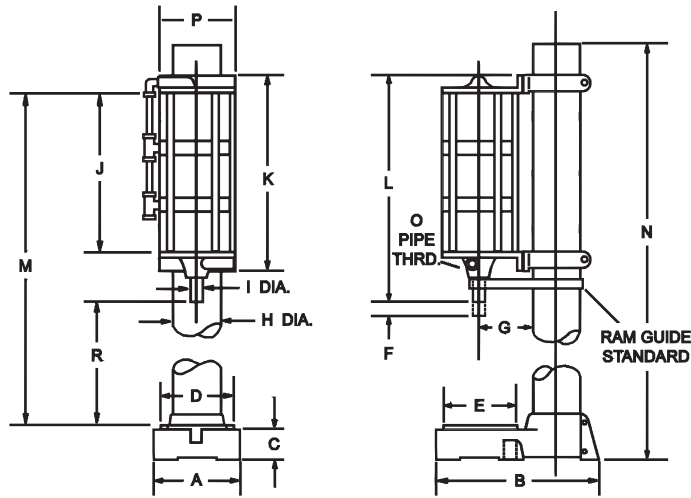

DOUBLE ACTING

Model	Bore Size	Power Capacity	Factor	A	B	C	D	E	F*	G	H	I	J	K	L	M	N*	O	P	R	Pipe Size	Weight
DAP58	5"	3 Ton	58-1	5 7/8"	11 7/8"	2 9/16"	5 1/16"	5 1/16"	2"	4 9/16"	3"	1"	12 9/16"	15 1/4"	17 3/4"	23"	26 1/2"	1/2"	6 1/4"	6"	1/2 NPT	99

*Longer stroke available on request. *Longer column available on request.

Triplex Press Double Acting Double Rod 3 Ton Model

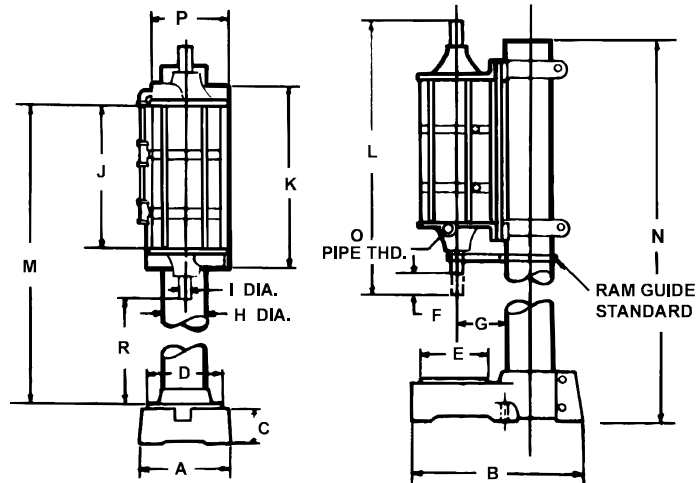

DOUBLE ACTING-AIR RETURN

Model	Bore Size	Power Capacity	Factor	A	B	C	D	E	F*	G	H	I	J	K	L	M	N*	O	P	R	Pipe Size	Weight
DAP58DR	5"	3 Ton	58-1	5 7/8"	11 7/8"	2 9/16"	5 1/16"	5 1/16"	2"	4 9/16"	3"	1"	12 9/16"	15 1/4"	22 1/4"	23"	26 1/2"	1/2"	6 1/4"	6"	1/2 NPT	100

*Longer stroke available on request. *Longer column available on request.

Press with Safety Control Systems – Pneumatic Series

Air-Mite press control safety systems offer a selection of pneumatic or electric two-hand safety controls.

Air-Mite PNEUMATIC SAFETY SYSTEMS include a rugged Air-Mite press – delivering a choice of eight power capacities – equipped with either a **basic or enhanced safety system**.

Basic System

(-33 pictured) includes an Air-Mite press, an SC3300 safety control, B742-5 5 micron mini filter – reg., a sized power valve and necessary fittings and tubing for an economical custom system – assembled, tested & ready to use.

Enhanced Systems

(-34) includes an Air-Mite press, an SC3400 two-hand safety control with **reset button**, B742-5 5 micron mini filter – reg., a power valve sized for your application, and fittings & tubing for complete system – assembled, tested & ready to use. Used with two and three position double piloted valves. For specific applications, consult factory.

(-35) An automated **clamp/hold** circuit includes all components of the (-34) plus an SC1111 logic box, an EOS sensor, and fittings and tubing – all assembled, tested and ready to use.

(-36 pictured) A clamp/hold circuit plus an SC2222 logic box with a **timer and/or an indicator** – all assembled, tested and ready to use.

(-38) A foot control valve with OSHA approved foot guard, a sized pilot valve, a B742-5 filter-reg., and a rugged Air-Mite press.

Selector Valve – can be furnished to operate different groups of presses or other pneumatic components. This option can be used with any of our control systems.

Custom Control Systems – Auxiliary controls and components to enhance primary and secondary press operations – such as grippers, slides, hold-downs – can be supplied for all press systems.

See page 15 for ordering information.



**Basic System
DAP38DR-2"-33 Pictured**

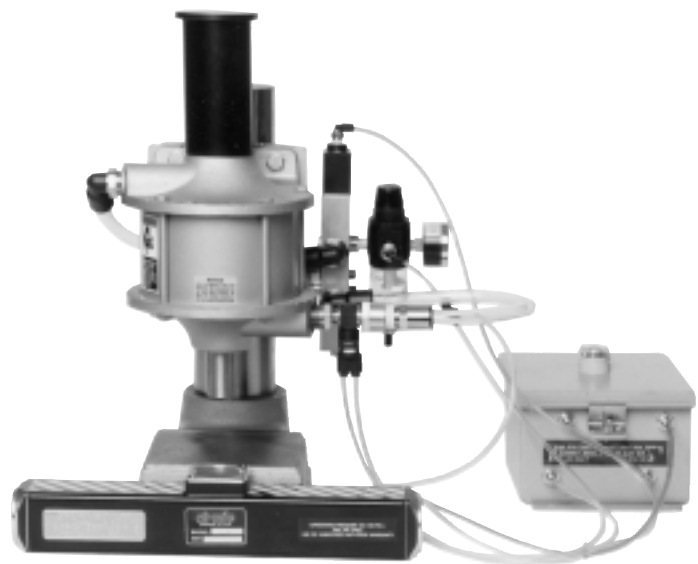

**Enhanced System
DAP19DR-2"-36 with
SC2222 Logic Box Pictured**

Safety Control Systems

Press with Safety Control Systems – Electric Series

Air-Mite ELECTRIC SAFETY SYSTEMS include a sized Air-Mite press with two hand safety controls in a choice of three actuator styles:

- EPB - Push Button
- EIR - Infra-Red
- EFO - Fiber Optic (non-contact)

Voltages (YY): Choice of four input-output voltage options:

- 00 - 120 v input & output
- 01 - Sink/source option for PCs or controllers
- 02 - 120 v input & 24 v DC output
- 03 - 24 v DC input and output

Electric safety control systems are equipped with a sized Air-Mite press supplied with either a basic or enhanced safety system.

Basic Electric System (-33EXX-YY)

Includes rugged and precise Air-Mite press, a two-hand safety control with a choice of actuators, a sized solenoid valve, connector with light wafer, and all necessary wiring, tubing and fittings for a complete ready-to-use work station.

Enhanced Electric Systems (-34EXX-YY)

A basic clamp and hold safety system without a timer for secondary operations. It includes a rugged and precise Air-Mite press, a two-hand safety control with **reset button** in a choice of actuator styles, a sized solenoid valve with light wafer and plug-in cables, and all necessary tubing and fittings for a complete ready-to-use work station.

(-36EXX-YY)

An automated **electric clamp/hold** circuit includes all components of the (-34EXX-YY) press system plus an end of stroke sensor, and an **adjustable digital timer** for a complete, ready-to-use work station.

See page 15 for ordering information.



**Basic System -
DAP19-2-33EFO-00 Pictured**



**Enhanced System
DAP38-2-36EFO-00 Pictured**

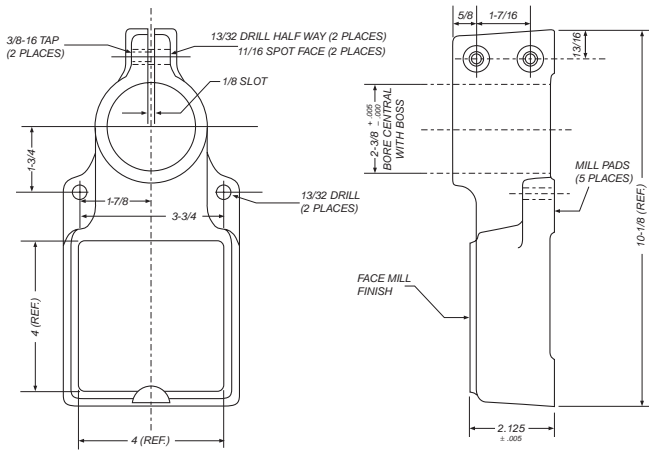

#40 Small Press Base Dimensions
Models 4, 7, & 14

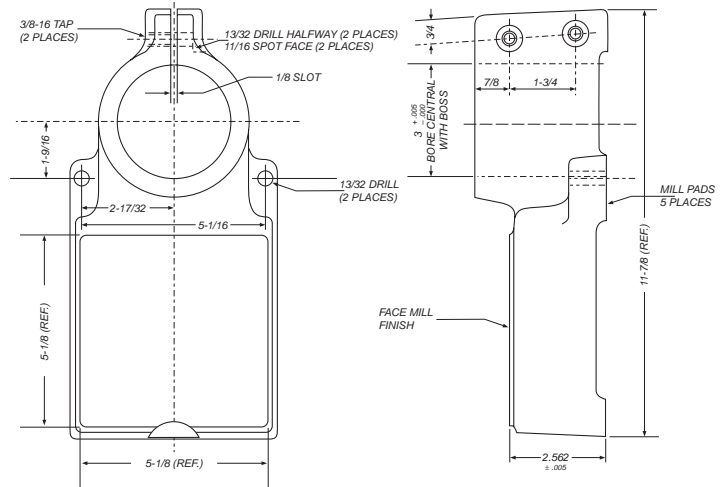

#42 Large Press Base Dimensions
Models 12, 19, 24, 38, & 58

Customizing Press Bases (Platens) To Your Requirements

Machining to Base: Bases can be machined for fixtures, dies & die sets, hold downs and slides. Machining includes tapped holes, milled slots and cutouts. Refer to the above dimensional data and templates provided below.

Subplates: For oversized parts such as printed circuit boards or chassis, subplates can be furnished to increase the dimensional size of press bases.

Templates: Fill in your machining requirements:

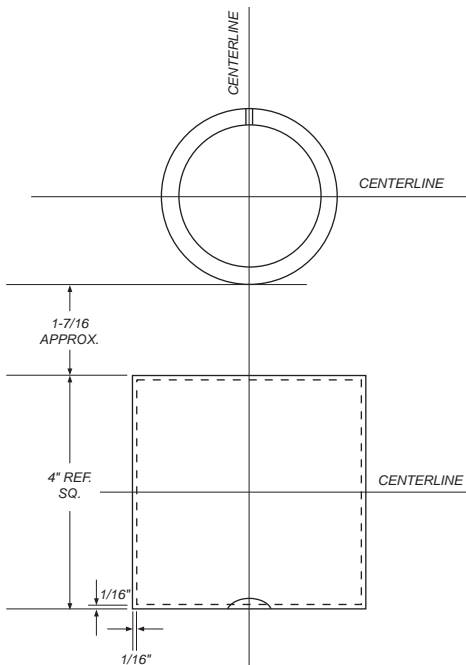

Small Press Base Dimensions
Models 4, 7, & 14

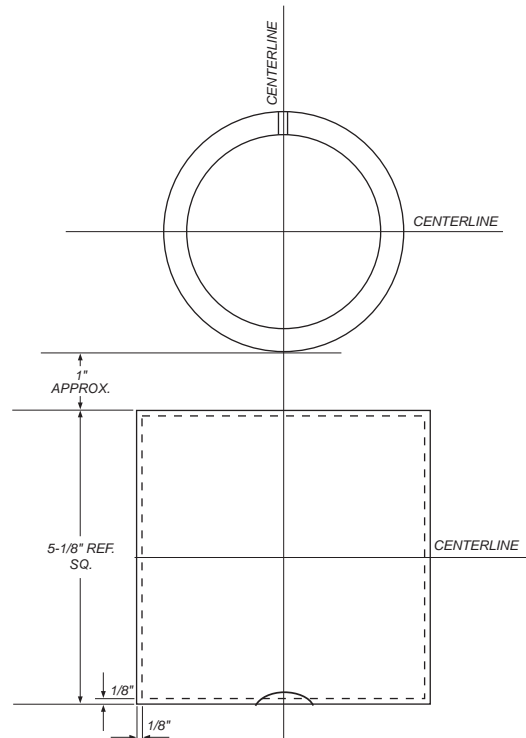

Large Press Base Dimensions
Models 12, 19, 24, 38, & 58

Press Base Dimensional Data

Press Base – Center Line to Center Line

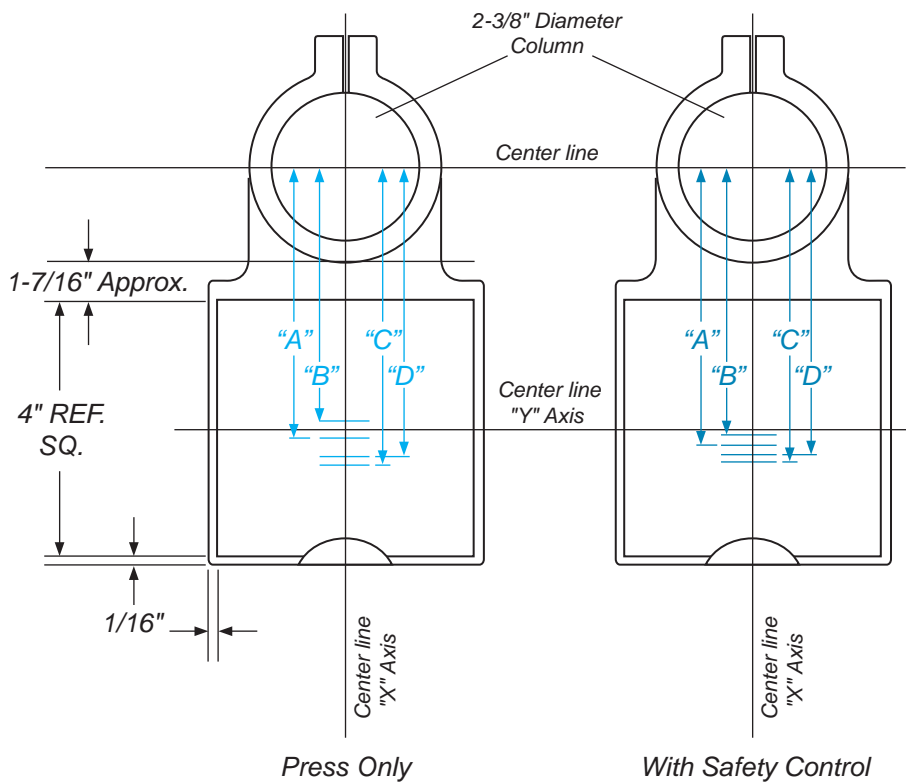

Small Base - #40 Dimensions Models 4, 7 & 14:

Press ONLY

- "A" = $5^{3/16}$ "
- "B" = $4^{15/16}$ "
- "C" = $5^{9/16}$ "
- "D" = $5^{5/16}$ "

Press with Safety Control

- "A" = $5^{5/16}$ "
- "B" = $5^{1/16}$ "
- "C" = $5^{11/16}$ "
- "D" = $5^{7/16}$ "

Press Models Referred To:

- "A" = All spring return 1 1/2" stroke
- "B" = All double acting 1" stroke
- "C" = All spring return over 1 1/2" stroke
- "D" = All double acting over 1" stroke
- "X" Axis = constant centerline dimension of milled surface on base
- "Y" Axis = variable centerline dimension which varies along "X" axis

Press Base – Center Line to Center Line

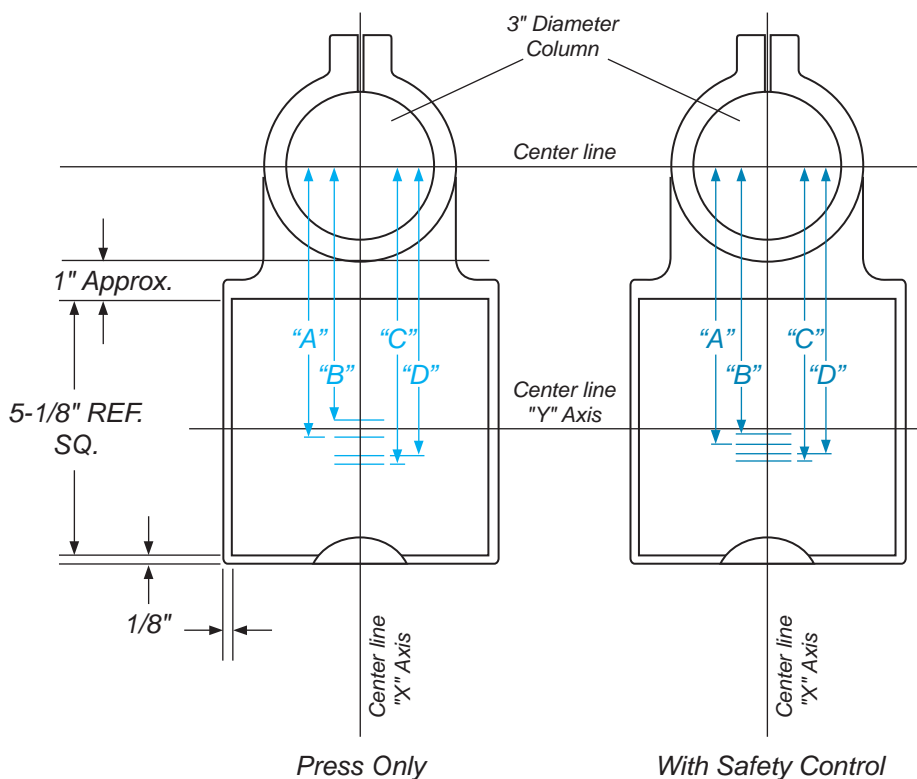

Large Base - #42 Dimensions Models 12, 19, 24, 38 & 58:

Press ONLY

- "A" = $5^{5/8}$ "
- "B" = $5^{7/16}$ "
- "C" = $6^{3/16}$ "
- "D" = 6"

Press with Safety Control

- "A" = $5^{3/4}$ "
- "B" = $5^{9/16}$ "
- "C" = $6^{5/16}$ "
- "D" = $6^{1/8}$ "

Press Models Referred To:

- "A" = All spring return 2" stroke
- "B" = All double acting 1 1/2" stroke
- "C" = All spring return over 2" stroke
- "D" = All double acting over 1 1/2" stroke
- "X" Axis = constant centerline dimension of milled surface on base
- "Y" Axis = variable centerline dimension which varies along "X" axis

Air-Mite Press Systems carries our “plug & play” and basic presses to the next level for those wanting a Turnkey operation. Applications include Curing, Bonding, Forming, Clamping, Cutting and Assembly.

This program is facilitated by a qualified group of Air-Mite approved North American distributors. This ensures knowledgeable and convenient cooperation.

Interesting systems range from aluminum and vinyl fabrications, electronics and printed circuit boards, fiber optics, cosmetics and pharmaceuticals, to housing trusses, hardware and portable electric tools. Additional useful applications can be found on the back cover of this brochure.

Air-Mite Press Systems utilize all models and styles of our presses. In addition, we manufacture all our cylinders ($\frac{3}{4}$ " to 5" bore) and all valving in house. Therefore, we can easily approach all projects in house.

Pictured right (top and center) are partial views of individual curing and bonding presses with separate platens. These Air-Mite systems can include one press or several presses in line with individual or common platen. We can use feeds, slides and grippers as required – a complete, integrated system can include timers, indicators and sequential valving. Air-Mite systems provide an extremely good rate of return on investment.

Pictured at right is a long-bed press before any controls are installed. 10 feet long is not unusual. For wider work, end loading bonding and curing systems with parallel presses are used. Air-Mite systems afford an extremely attractive rate of return on investment. We invite your inquiries.



View of Air-Mite Presses with oversized platens. Photo courtesy of a leading Instrument Manufacturer.

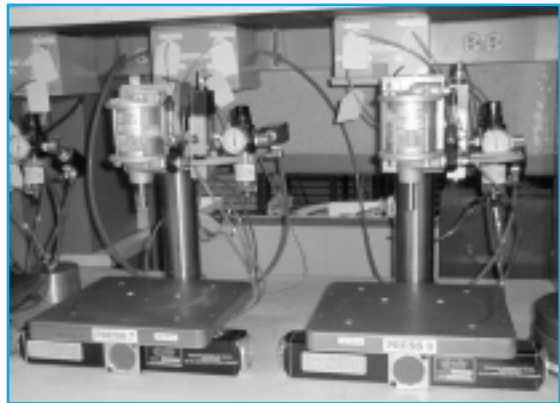

Straight-on view of Air-Mite Presses with oversized platens from a leading Instrument Manufacturer.

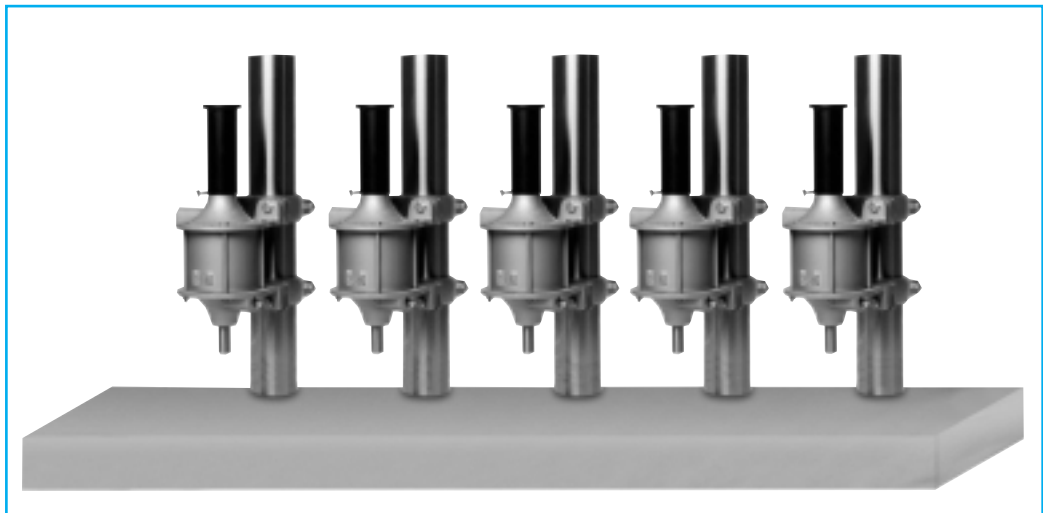

Long-bed press before any controls are installed.

How to Order

A Step-By-Step Guide

I	II	III	IV	V
STYLE	MODEL	FORCE(TONS) @ 100 psi	ROD END(S)	STROKE LENGTHS
Spring Return (AP) or Double Acting (DAP)	4 7 12 14 19 24 38 58	1/4 1/3 1/2 3/4 1 1 1/4 2 3	Single- no suffix Double- DR	Spring Return-1.5 thru 4" Double Acting-1 thru 6" Longer strokes-as required
Tandem cylinders for increased force used on 14, 24 & 38 presses/Triplex cylinders used on 58 press				
VI	VII	VIII	IX	
CYCLING CONTROLS	SAFETY SYSTEM CONTROL TYPE*	DAYLIGHT CLEARANCE**	ROD END OPTIONS	
Speed Control Valves -control on extend stroke (SE) -control on retract stroke (SR)	Pneumatic: Basic -33 Enhanced -34 -35 -36 -38	Electric: Basic -33EXX-YY Enhanced -34EXX-YY -35EXX-YY -36EXX-YY	See below –6" standard**– adjustable up and down Increased clearance– specify & order extra column	Type 1 = Blank (plain) rod end Type 2 = Full male thread Type 3 = Reduced male thread Type 4 = Female thread Type 5 = Per customer requirements WF=Wrench flats
Quick Exhaust Valves -control on extend stroke (QE) -control on retract stroke (QR)				
	XX=Actuator type: Push Button (PB), Infra-Red (IR), Fiber Optic (FO) YY=Voltage options: 00=120v input & output 01=Contact output for PC's 02=120v input & 24v DC output 03=24v DC input & 24v DC output			

*See pp. 10-11 for detailed information on safety systems

Optional Features

- **Additional rod extension** – as required
- **Ram guides** – for non-rotation feature – see data on p. 3
- **Daylight clearance** – 6" standard – Increased as required by ordering extra column – see VIII above
- **Bases – Machining** – see template & dimensional data – p. 12
- **Piston rods** – stainless or chrome
- **Columns** – stainless or chrome

Ordering Examples

To order a press, select from columns I thru IX – Specify daylight clearance beyond standard 6" height by using (/) after stroke length or safety control system.

Example: You require a double acting press to provide 1 ton of force with a 2" stroke and a machined rod with male threads and wrench flats. Order as follows: DAP19-2"-Type 2-WF.

Example: You require a press equipped with a pneumatic safety control system for a clamp & hold application. The press should deliver 2 tons of force with a 3" stroke, a double rod end, both rods threaded with full male threads and 10" daylight clearance. Order as follows: DAP38DR-3"-35/10"-Type 2.

**** To maintain 6" clearance for longer strokes**, a ratio of inch/stroke to inch/column is as follows: for all models except the tandem and triplex presses—1" extra stroke requires 1" extra column. For tandem presses—1" extra stroke requires 2" extra column. For triplex presses—1" extra stroke requires 3" extra column.

For increased daylight clearance beyond 6", the ratio of inch/daylight to inch/column is 1-1. Eg., 1" extra daylight requires 1" extra column, 2" extra daylight requires 2" extra column, etc. for all presses regardless of short or longer stroke lengths.

Useful Applications – AIR-MITE PRESS SYSTEMS

Partial List of Sub-Assembly Applications:

Advertising Novelties

Wiring Harnesses

A/C Hose Assemblies

Electronic Connectors

Television Antennas

Aircraft

Security Systems

Locks

Hardware

Printed Circuit Boards

Costume Jewelry

Luggage

Electric Motors

Shock Absorbers

Indicator Lights

Fiber Optic Cables

Electric Power Tools

Passenger Rail Cars

Military Applications:

Bomb Fuses

Timing Devices

Quick Erecting Field Hospitals

Quick Erecting Hangars

Bullet Reloading

Antennas

Pictured at right is an Air-Mite press operating in the aluminum & vinyl window fabrication industry. Air-Mite has been the standard for this industry since its inception.



Courtesy of a leading North American manufacturer of aluminum & vinyl windows.

Contact Air-Mite for Your PRESSing Needs

**AIR-MITE
DEVICES, INC.**

4739 W. Montrose Avenue • Chicago, IL 60641

Phone: 773-286-3393 • Fax: 286-4703

www.airmite.com • E-mail airmite@mindspring.com