

Vane pumps for PTO drives type PFEO-41 and PFEDO-43

fixed displacement, DIN ISO 6162-1, square flange

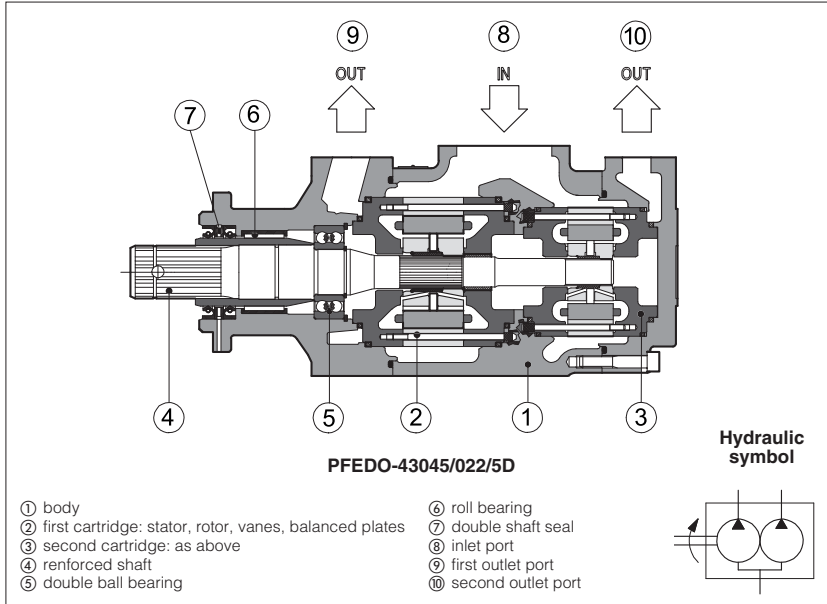

Fixed displacement vane pumps specially designed for direct installation on PTO drives of mobile vehicles and derived from PFE standard versions but with:

- 4 holes, square mounting flange according to DIN ISO 6162-1 for direct connection to PTO;
- DIN 5462 reinforced splined shaft, specially supported by a double ball bearing and a roll bearing for high radial loads;
- double shaft seal to prevent contamination between the PTO gearbox fluid and the pump fluid.

They are available in single cartridge execution (PFEO) or with double cartridge in a single body (PFEDO).

Easy installation due to the possibility of inlet/outlet ports orientation and simplified maintenance due to the quick cartridge replacement.

Wide displacement range: from 29 to 85 cm³/rev for PFEO, from 29+16 to 85+44 for PFEDO.

Max pressure up to 210 bar.

1 MODEL CODE

	PFEDO	-	43		045	/	022	/	5		D		TA		**		/*
<p>PFEO = fixed displacement vane pump PFEDO = fixed displacement double vane pump</p> <p>Models: 41 = for PFEO, see section 3 43 = for PFEDO, see section 4</p> <p>Displacement [cm³/rev] PFEO, see section 3. Displacement of first element [cm³/rev] PFEDO, see section 4.</p> <p>Displacement of second element [cm³/rev], PFEDO, see section 4.</p>															<p>Seals material: omit for NBR (mineral oil & water glycol) PE = FPM</p> <p>Series number</p> <p>Ports orientation, see section 5</p> <p>Direction of rotation (viewed at the shaft end): D = clockwise (supplied standard if not otherwise specified) S = counterclockwise</p> <p>Note: PFEO and PFEDO are not reversible</p> <p>Drive shaft, splined type DIN 5462.</p>		

Note: model type PFEO-42* with max pressure up to 280 bar with displacement 045, 056, 070 and 085, available on request.

2 MAIN CHARACTERISTICS

Installation position	Any position.								
Loads on the shaft	Axial loads are not allowed. For max allowed radial load see diagram 7 in section 6								
Ambient temperature	from -20°C to +70°C								
Fluid	Hydraulic oil as per DIN 51524...535; for other fluids see section 1								
Recommended viscosity	<table border="0" style="width: 100%;"> <tr> <td style="width: 30%;">max at cold start</td> <td>1000 mm²/s (low speed 400 rpm and low pressure recommended)</td> </tr> <tr> <td>max at full power</td> <td>100 mm²/s</td> </tr> <tr> <td>during operation</td> <td>24 mm²/s</td> </tr> <tr> <td>min at full power</td> <td>10 mm²/s</td> </tr> </table>	max at cold start	1000 mm ² /s (low speed 400 rpm and low pressure recommended)	max at full power	100 mm ² /s	during operation	24 mm ² /s	min at full power	10 mm ² /s
max at cold start	1000 mm ² /s (low speed 400 rpm and low pressure recommended)								
max at full power	100 mm ² /s								
during operation	24 mm ² /s								
min at full power	10 mm ² /s								
Fluid contamination class	ISO 4401 class 21/19/16 NAS 1638 class 10 (filters at 25 µm value with β ₂₅ ≥ 75 recommended)								
Fluid temperature	-20°C +60°C -20°C +50°C (water glycol) -20°C +80°C (/PE seals)								
Recommended suction line pressure	from -0,5 to 1,5 bar for speed up to 1800 rpm; from 0 to +1,5 bar for speed over 1800 rpm								

3 OPERATING CHARACTERISTICS OF PFEO at 1450 rpm (based on mineral oil ISO VG 46 at 50°C)

Model	Displacement cm ³ /rev	Max pressure (1)	Speed range rpm (2)(3)	7 bar (4)		140 bar (4)		max pressure (4)	
				l/min	kW	l/min	kW	l/min	kW
PFEO-41029	29,3	210 bar	400-2500	41	0,8	37	10	34	14,7
PFEO-41037	36,6			52	1	48	12,5	45	18,3
PFEO-41045	45,0			64	1,3	60	16	57	22,6
PFEO-41056	55,8			80	1,6	75	21	72	28
PFEO-41070	69,9			101	2	95	26	91	35
PFEO-41085	85,3			400-2000	124	2,4	118	32	114

4 OPERATING CHARACTERISTICS OF PFEDO at 1450 rpm (based on mineral oil ISO VG 46 at 50°C)

PFEDO-43 are composed of one cartridge PFE-41 and one cartridge PFED-31.

Model	Displacement [cm ³ /rev]		Max pressure (1)	Speed range min/max (2) rpm (3)	7 bar (4)				140 bar (4)				210 bar (4)			
	1°cartridge	2°cartridge			1°flow		2°flow		1°flow		2°flow		1°flow		2°flow	
PFEDO-43					l/min	Kw	l/min	Kw	l/min	Kw	l/min	Kw	l/min	Kw	l/min	Kw
PFEDO-43 029/016	29,3	16,5	210 bar	400-2500	41	0,8	23	0,5	37	10	19	5	34	14	16	6,5
PFEDO-43 029/022		21,6			41	0,8	30	0,6	37	10	26	7	34	14	23	10
PFEDO-43 029/028		28,1			41	0,8	40	0,8	37	10	36	10	34	14	33	14
PFEDO-43 037/016	36,6	16,5			52	1	23	0,5	48	12,5	19	5	45	18	16	6,5
PFEDO-43 037/022		21,6			52	1	30	0,6	48	12,5	26	7	45	18	23	10
PFEDO-43 037/028		28,1			52	1	40	0,8	48	12,5	36	10	45	18	33	14
PFEDO-43 037/036	45	35,6			52	1	51	1	48	12,5	46	12,5	45	18	43	18
PFEDO-43 045/016		16,5			64	1,3	23	0,5	60	24	19	5	57	24	16	6,5
PFEDO-43 045/022		21,6			64	1,3	30	0,6	60	16	26	7	57	24	23	10
PFEDO-43 045/028	55,8	28,1			64	1,3	40	0,8	60	16	36	10	57	24	33	14
PFEDO-43 045/036		35,6			64	1,3	51	1	60	16	46	12,5	57	24	43	18
PFEDO-43 045/044		43,7			64	1,3	63	1,3	60	16	58	15,5	57	24	55	23
PFEDO-43 056/016	69,8	16,5			80	1,6	23	0,5	75	21	19	5	72	30	16	6,5
PFEDO-43 056/022		21,6			80	1,6	30	0,6	75	21	26	7	72	30	23	10
PFEDO-43 056/028		28,1			80	1,6	40	0,8	75	21	36	10	72	30	33	14
PFEDO-43 056/036	85,3	35,6			80	1,6	51	1	75	21	46	12,5	72	30	43	18
PFEDO-43 056/044		43,7			80	1,7	63	1,3	75	21	58	15,5	72	30	55	23
PFEDO-43 070/016		16,5			101	2	23	0,5	95	26	19	5	91	37	16	6,5
PFEDO-43 070/022	85,3	21,6			101	2	30	0,6	95	26	26	7	91	37	25	10
PFEDO-43 070/028		28,1			101	2	40	0,8	95	26	36	10	91	37	33	14
PFEDO-43 070/036		35,6			101	2	51	1	95	26	46	12,5	91	37	43	18
PFEDO-43 070/044	400-2000	43,7			101	2	63	1,3	95	26	58	18,5	91	37	55	23
PFEDO-43 085/016		16,5			124	2,4	23	0,5	118	32	19	5	114	46	16	6,5
PFEDO-43 085/022		21,6			124	2,4	30	0,6	118	32	26	7	114	46	23	10
PFEDO-43 085/028	400-2000	28,1	124	2,4	40	0,8	118	32	36	10	114	46	33	14		
PFEDO-43 085/036		35,6	124	2,4	51	1	118	32	46	12,5	114	46	43	18		
PFEDO-43 085/044		43,7	124	2,4	63	1,3	118	32	58	15,5	114	46	55	23		

- (1) Max pressure is 160 bar for /PE version and water glycol fluid
- (2) Max speed is 1800 rpm for /PE version; 1500 rpm for water glycol fluid
- (3) Max speed for venting = 2700 rpm
- (4) Flow rate and power consumption are proportional to the rotation speed

5 PORT ORIENTATION (pumps viewed from the shaft end)

Pumps can be supplied with oil ports oriented in different configurations in relation to the drive shaft. Port orientation of PFEO (the first element for PFEDO) is as follows (viewed from the shaft end);
T = inlet and outlet ports on the same axis (standard)
U = outlet orientated 180° with respect to the inlet
V = outlet oriented 90° with respect to the inlet
W = outlet oriented 270° with respect to the inlet
 Outlet port (P2) of second element for PFEDO can be orientated, relative to the inlet port (T1), in 8 positions at 45° (**O, A, B, C, D, E, F, G**)
 Ports orientation can be easily changed by rotating the pump body that carries inlet port.

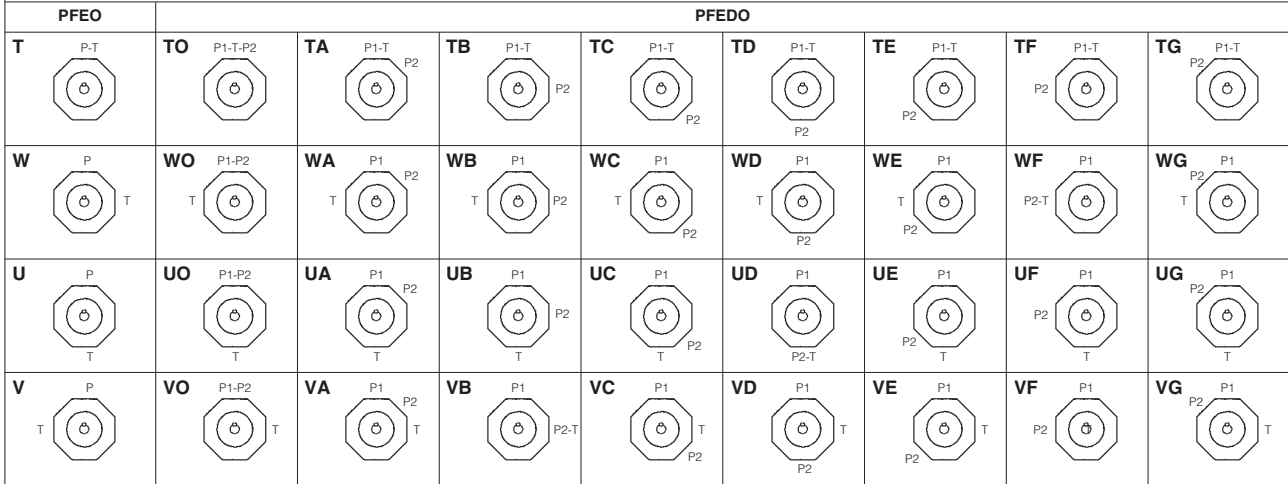

P1 = outlet port of first element; P2 = outlet port of second element; T = inlet port

6 DIAGRAMS (based on mineral oil ISO VG 46 at 50°C)

1 = Torque versus pressure diagram
PFEO-41

2 = Torque versus pressure diagram
PFEDO-43 (the total shaft torque is the sum of the first cartridge + the second one).

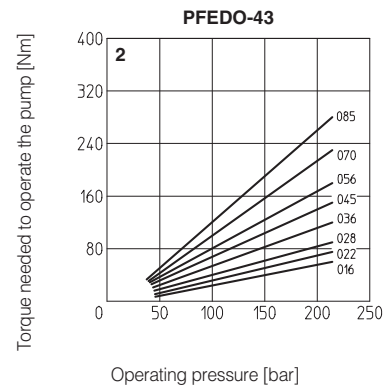
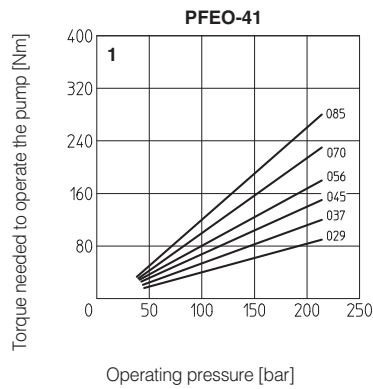

PFEO-41
PFEDO-43: First element
(cartridge SC-PFE-41)**

3 = Flow versus speed diagram with pressure variation from 7 bar to 210 bar.

4 = Power consumption versus speed diagram at 140 bar. Power consumption is proportional to operating pressure.

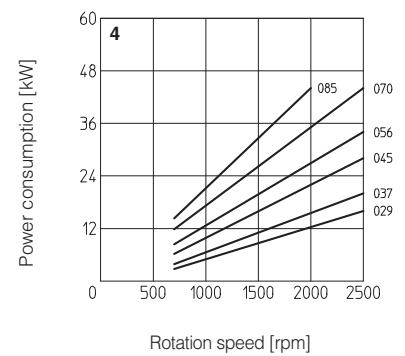
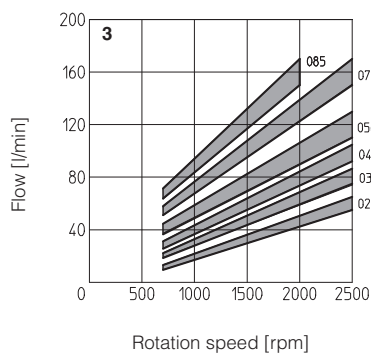

PFEDO-43: Second element
(cartridge SC-PFED-31)**

5 = Flow versus speed diagram with pressure variation from 7 bar to 210 bar.

6 = Power consumption versus speed diagram at 140 bar. Power consumption is proportional to operating pressure.

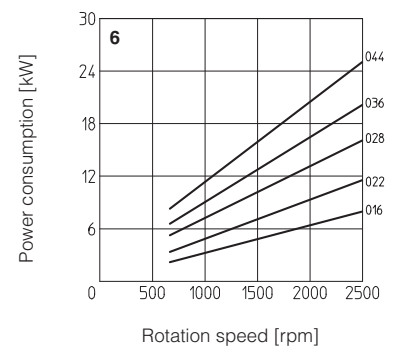
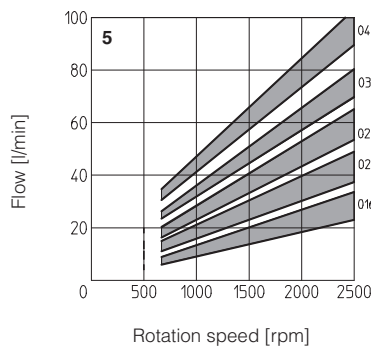

PFEO and PFEDO

7 = max allowed radial load versus speed diagram

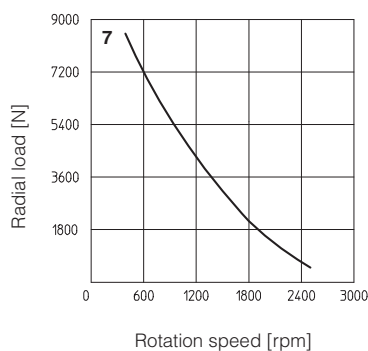

7 DRIVE SHAFT

Spline shaft DIN 5462

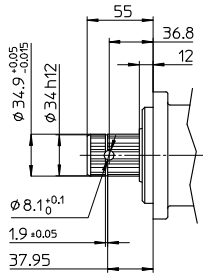

Max Torque 750 Nm

The total torque applied to the shaft of the pump is the sum of the single torque needed for operating each single cartridge and it is necessary to verify that this total torque applied to the drive shaft is not higher than max allowed.
The values of torque needed to operate each single cartridge are shown on the "torque versus pressure diagram" at section 6.

8 DIMENSIONS [mm]

PFEO-41*

Mounting flange
DIN ISO 6162-1; SAE J518 "C"
SAE flanges
port **P = 1"**
port **T = 1 1/2"**

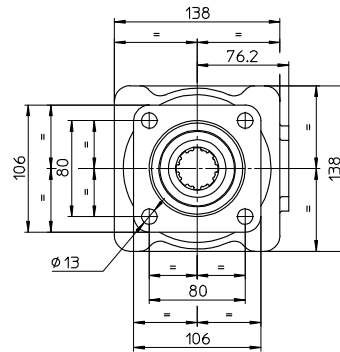
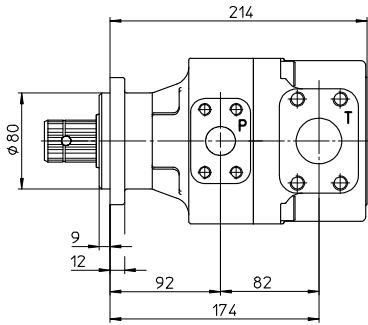

Mass: 18 kg

PFEDO-43*

Mounting flange
DIN ISO 6162-1; SAE J518 "C"
SAE flanges
port **P1 = 1"**
port **P2 = 3/4"**
port **T = 2 1/2"**

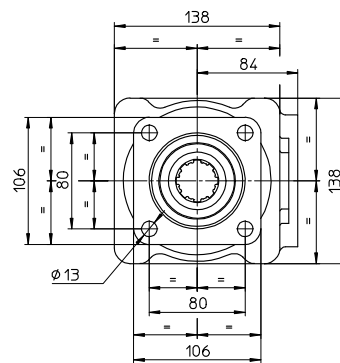
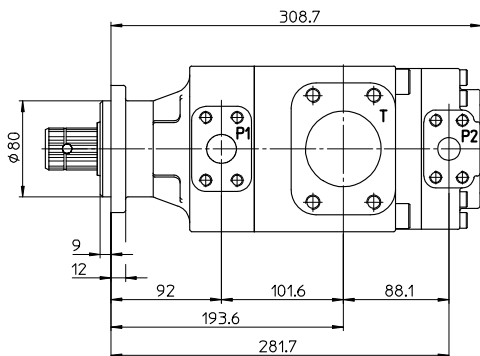

Mass: 25 kg