

Proportional throttle cartridges type LIQZO-TEs, 2-way

with position transducer, ISO 7368 sizes from 16 to 50

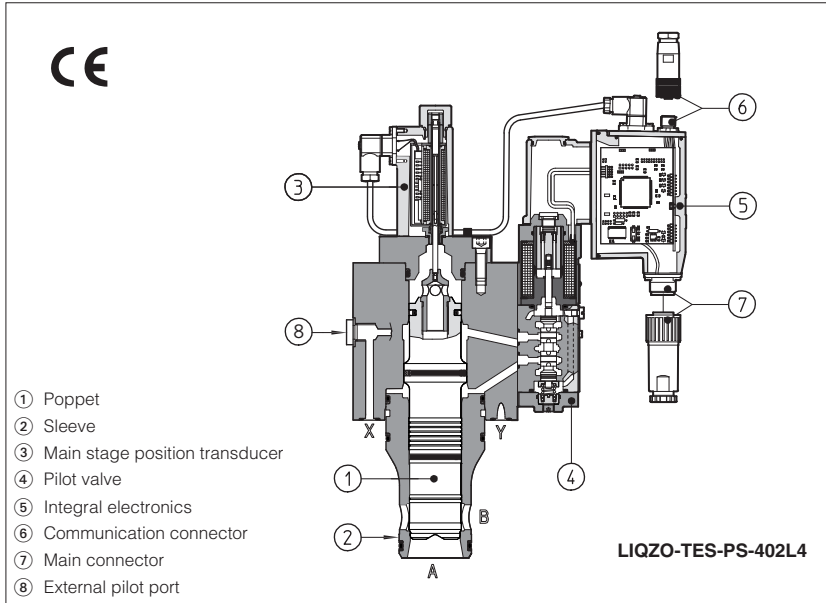

LIQZO-TE are 2-way proportional cartridge valves, designed for mounting in manifold blocks which provide proportional not compensated flow control according to the electronic reference signal.

They operate in association with electronic drivers, see section 2, which supply the proportional valves with proper current to align valve regulation to the reference signal supplied to the electronic driver.

They are available in different executions:

- -T, with position transducer ③;
- -TE, -TES as -T plus analogue (TE) or digital (TES) integral electronics ⑤.

The regulation is operated by means of a poppet ① with double piloting area, sliding into a sleeve ② and provided of integral LVDT position transducer ③.

The poppet is controlled in closed loop by means of a proportional directional valve ④ type DHZO, see table F160.

The integral electronics ⑤ ensures factory presetting, fine functionality plus valve-to-valve interchangeability and simplified wiring and installation.

The electronic main connector ⑦ is fully interchangeable for -TE and -TES executions.

Standard 7 pin main connector is used for power supply, analog input reference and monitor signals.

12 pin connector is used for option /Z.

Following communication interfaces ⑥ are available for the digital -TES execution:

- -PS, Serial communication interface for configuration, monitoring and firmware updating through Atos PC software
- -BC, CANopen interface
- -BP, PROFIBUS-DP interface

The valves with -BC and -BP interfaces can be integrated into a fieldbus communication network and thus digitally operated by the machine control unit.

Typical applications: plastic injection and blow moulding, foundry and steel plants.

Mounting surface: ISO 7368

Sizes from 16 to 50

Max flow up to 2000 l/min with differential pressure $\Delta p = 5$ bar, see section 3.

Max pressure = 350 bar.

1 MODEL CODE

LIQZO	- TES	- PS	- 25	2	L4	/ *	**	/*
Flow control valve								
<p>T = with position transducer TE = as T plus integral analog electronics TES = as T plus integral digital electronics</p> <p>Communication interfaces (only for TES) PS = Serial BC = CANopen BP = PROFIBUS DP</p> <p>Valve size, see section 3 16 25 32 40 50</p> <p>Valve configuration, see section 3 2 = 2 way</p> <p>Versions with reduced flow are available on request *2L2.</p>								
<p>Seals material: omit for NBR (mineral oil & water glycol) PE = FPM</p> <p>Series number</p> <p>Electronics options, for -TE execution see section 6: I = current reference input and monitor (4÷20 mA) F = fault signal Q = enable signal Z = enable, fault and monitor signals (12 pin connector)</p> <p>Electronics options, for -TES execution see section 8: I = current reference input and monitor (4÷20 mA) Z = double power supply, enable fault and monitor signals (12 pin connector)</p> <p>Spool type (regulating characteristics): L4 = linear</p>								

2 ELECTRONIC DRIVERS

Valve model	-T	-TE	-TES
Drivers model	E-ME-T	E-RI-TE	E-RI-TES
Data sheet	G140	G200	G210

Note: For power supply and communication connector see section 15

3 HYDRAULIC CHARACTERISTICS (based on mineral oil ISO VG 46 at 50 °C)

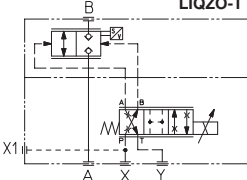
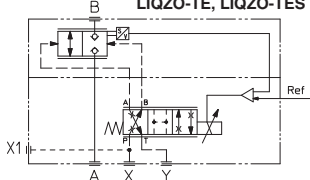
Hydraulic symbols					
Model	LIQZO-T*				
Size	16	25	32	40	50
Max regulated flow at $\Delta p = 5$ bar	250	500	800	1200	2000
at $\Delta p = 10$ bar	350	700	1100	1700	2800
Max permissible flow	600	1200	1800	2500	4000
Max pressure [bar]	350				
Nominal flow of pilot valve at $\Delta p = 70$ bar [l/min]	15				
Leakage of pilot valve at $P = 100$ bar [l/min]	1				
Response time 0 ÷ 100% step signal [ms]	22	25	30	32	40
Piloting volume [cm ³]	1,58	2,16	7,0	9,4	17,7
Hysteresis [% of the max flow]	$\leq 0,5\%$				
Repeatability [% of the max flow]	$\pm 0,5\%$				
Thermal drift	zero point displacement < 1% at $\Delta T = 40^\circ C$				

Notes:

- Above performance data refer to valves coupled with Atos electronic drivers, see section 2.
- Recommended piloting pressure is 140 ÷ 160 bar.
- In case of long time shutdown of the hydraulic supply to the pilot valve, the driver has to be switched off to avoid its overheating.

4 GENERAL NOTES

LIQZO-T* proportional valves are CE marked according to the applicable Directives (e.g. Immunity/Emission EMC Directive and Low Voltage Directive).

Installation, wirings and start-up procedures must be performed according to the general prescriptions shown in table F003 and in the installation notes supplied with relevant components.

The electrical signals of the valve (e.g. monitor signals) must not be directly used to activate safety functions, like to switch-ON/OFF the machine's safety components, as prescribed by the European standards (Safety requirements of fluid technology systems and components-hydraulics, EN-982).

5 CONNECTIONS FOR -T EXECUTION

SOLENOID POWER SUPPLY CONNECTOR SP-666	
PIN	Signal description
1	SUPPLY
2	SUPPLY
3	GND

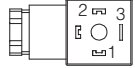

POSITION TRANSDUCER CONNECTOR SP-345	
SIZES 16 ÷ 40	
PIN	Signal description
1	OUTPUT SIGNAL
2	SUPPLY -15 V _{DC}
3	SUPPLY +15 V _{DC}
4	GND

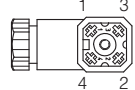

POSITION TRANSDUCER CONNECTOR ZBE 06	
SIZE 50	
PIN	Signal description
1	OUTPUT SIGNAL
2	SUPPLY +24 V _{DC}
3	GND
4	NC

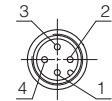

6 ANALOG INTEGRAL DRIVERS -TE - OPTIONS

Standard driver execution provides on the 7 pin main connector:

- Power supply** - 24V_{DC} must be appropriately stabilized or rectified and filtered; a 2,5 A safety fuse is required in series to the driver power supply. Apply at least a 10000 $\mu F/40$ V capacitance to single phase rectifiers or a 4700 $\mu F/40$ V capacitance to three phase rectifiers
- Reference input signal** - analog differential input with ± 10 V_{DC} nominal range (pin D,E), proportional to desired valve spool position
- Monitor output signal** - analog output signal proportional to the actual valve's spool position with ± 10 V_{DC} nominal range

Following options are available to adapt standard execution to special application requirements:

6.1 Option /F

It provides a Fault output signal in place of the Monitor output signal, to indicate fault conditions of the driver (cable interruption of spool transducers or reference signal - for /I option): Fault presence corresponds to 0 V_{DC}, normal working corresponds to 24 V_{DC}

6.2 Option /I

It provides the 4÷20 mA current reference and monitor signals instead of the standard ± 10 V_{DC}. It is normally used in case of long distance between the machine control unit and the valve or where the reference signal can be affected by electrical noise; the valve functioning is disabled in case of reference signal cable breakage.

6.3 Option /Q

It provides the possibility to enable or disable the valve functioning without cutting the power supply (the valve functioning is disabled but the driver current output stage is still active). To enable the driver supply a 24V_{DC} on the enable input signal.

6.4 Option /Z

This option includes /F and /Q features, plus the Monitor output signal. When the driver is disabled (0 V_{DC} on Enable signal) Fault output is forced to 0 V_{DC}.

6.5 Possible combined options: /FI and /IZ

7 ANALOG INTEGRAL DRIVERS -TE - MAIN FUNCTIONS AND ELECTRONIC CONNECTIONS

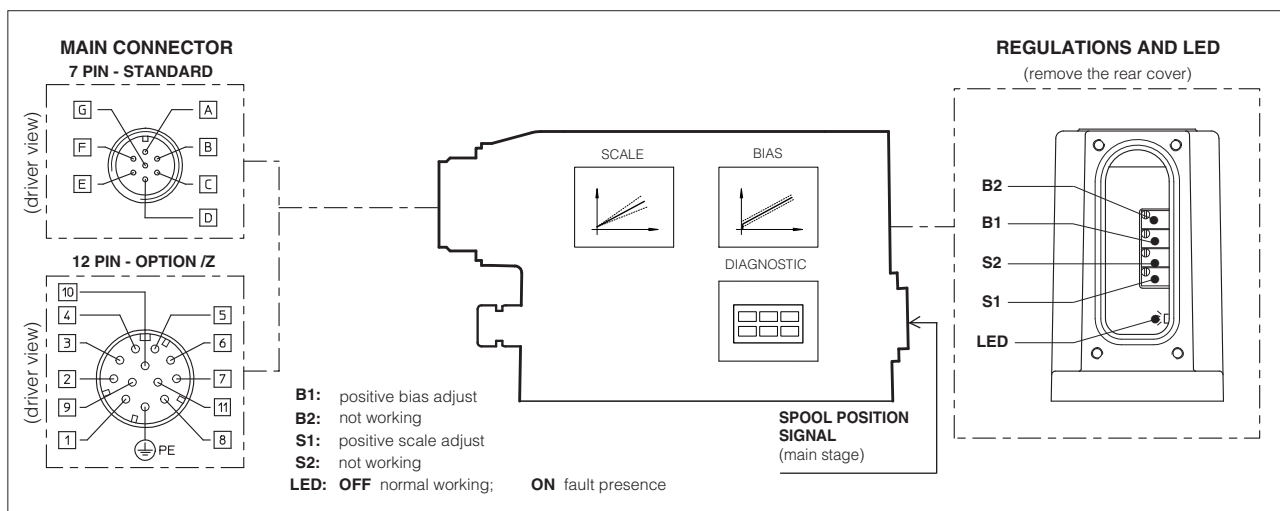

7.1 ELECTRONIC CONNECTIONS - 7 & 12 PIN MAIN CONNECTORS

Standard 7pin	/Z option 12pin	SIGNAL	TECHNICAL SPECIFICATIONS	NOTES
A	1	V+	Power supply 24 Vdc for solenoid power stage and driver logic	Input - power supply
B	2	V0	Power supply 0 Vdc for solenoid power stage and driver logic	Gnd - power supply
C (1)	7	AGND	Ground - signal zero for MONITOR signal (for standard, /Z option)	Gnd - analog signal
	3	ENABLE	Enable (24 Vdc) or disable (0 Vdc) the driver (for /Q and /Z options)	Input - on/off signal
D	4	INPUT+	Reference analog differential input: 0 ÷ +10 Vdc maximum range (4 ÷ 20 mA for /I option)	Input - analog signal
E	5	INPUT -		
F (2)	6	MONITOR	Monitor analog output: ±10 Vdc maximum range (4 ÷ 20 mA for /I option)	Output - analog signal
	11	FAULT	Fault (0V) or normal working (24V) (for /F and /Z options)	Output - on/off signal
-	8	R_ENABLE	Repeat Enable - output repetition of Enable input	Output - on/off signal
-	9	NC	do not connect	Output - on/off signal
-	10	NC	do not connect	Output - on/off signal
G	PE	EARTH	Internally connected to the driver housing	

Notes:

(1) with /Q option ENABLE signal replaces AGND on pin C; MONITOR signal is referred to pin B

(2) with /F option FAULT signal replaces MONITOR on pin F.

- A minimum time of 50ms to 100ms have be considered between the driver energizing with the 24 Vdc power supply and when the valve is ready to operate. During this time the current to the valve coils is switched to zero.

8 DIGITAL INTEGRAL DRIVERS -TES - OPTIONS

Standard driver execution provides on the 7 pin main connector:

- Power supply** - 24Vdc must be appropriately stabilized or rectified and filtered; a 2,5 A safety fuse is required in series to each driver power supply
Apply at least a 10000 µF/40 V capacitance to single phase rectifiers or a 4700 µF/40 V capacitance to three phase rectifiers
- Reference input signal** - analog differential input with ±10Vdc nominal range (pin D,E), proportional to desired valve spool position
- Monitor output signal** - analog output signal proportional to the actual valve's spool position with ±10Vdc nominal range

Following options are available to adapt standard execution to special application requirements:

8.1 Option /I

It provides 4÷20 mA current reference and monitor signals instead of the standard ±10 V.

It is normally used in case of long distance between the machine control unit and the valve or where the reference signal can be affected by electrical noise; the valve functioning is disabled in case of reference signal cable breakage.

8.2 Option /Z

It provides on the 12 pin main connector the following additional features:

Logic power supply

Separated power supply for the solenoid (pin 1, 2) and for the digital electronic circuits (pin 9, 10).

Cutting solenoid power supply allows to interrupt the valve functioning but keeping energized the digital electronics thus avoiding fault conditions of the machine fieldbus controller. This condition allows to realize safety systems in compliance with European Norms EN13849-1 (ex EN954-1).

Enable Input Signal

To enable the driver, supply 24Vdc on pin 3 referred to pin 2: when the Enable signal is set to zero the valve functioning is disabled (zero current to the solenoid) but the driver current output stage is still active.

Fault Output Signal

Fault output signal indicates fault conditions of the driver (solenoid short circuits/not connected, reference signal cable broken for 4÷20mA input, etc.). Fault presence corresponds to 0 Vdc, normal working corresponds to 24Vdc (pin 11 referred to pin 2): Fault status is not affected by the Enable input signal

8.3 Possible combined options: /IZ

9 DIGITAL INTEGRAL DRIVERS -TES - MAIN FUNCTIONS AND ELECTRONIC CONNECTIONS

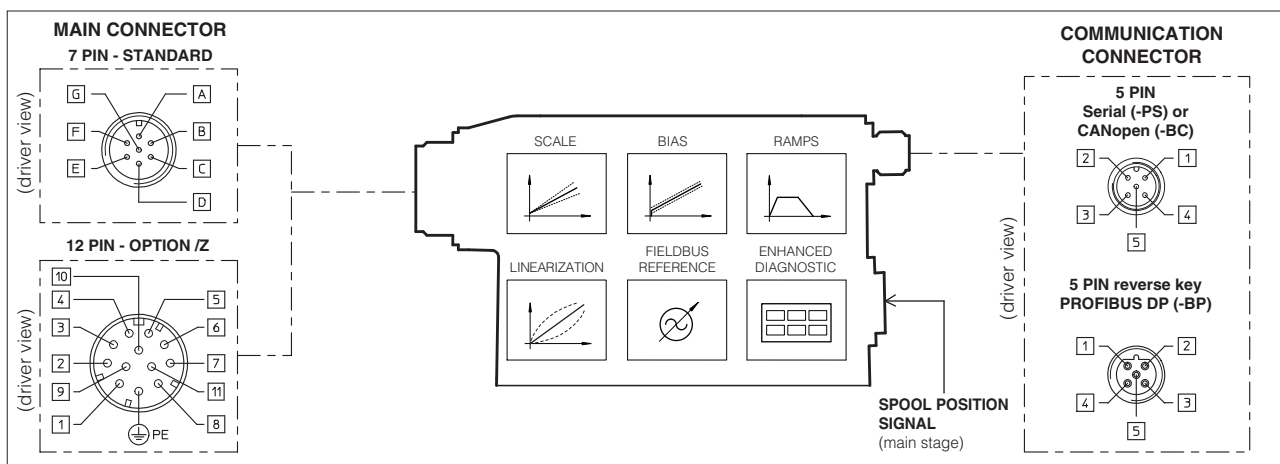

9.1 ELECTRONIC CONNECTIONS - 7 & 12 PIN MAIN CONNECTORS

Standard 7pin	/Z option 12pin	SIGNAL	TECHNICAL SPECIFICATIONS	NOTES
A	1	V+	Power supply 24 Vdc for solenoid power stage (and for driver logic on 7 pin connection)	Input - power supply
B	2	V0	Power supply 0 Vdc for solenoid power stage (and for driver logic on 7 pin connection)	Gnd - power supply
-	3	ENABLE	Enable (24 Vdc) or disable (0 Vdc) the driver	Input - on/off signal
D	4	INPUT+	Reference analog input: 0 ÷ +10 Vdc maximum range (4 ÷ 20 mA for /I option) standard: differential input; /Z option: common mode INPUT+ referred to AGND	Input - analog signal
E	-	INPUT -		
C	5	AGND	Ground - signal zero for MONITOR signal signal zero for INPUT+ signal (only for /Z option)	Gnd - analog signal
F	6	MONITOR	Monitor analog output: ±10 Vdc maximum range (4 ÷ 20 mA for /I option)	Output - analog signal
-	7	NC	do not connect	
-	8	NC	do not connect	
-	9	VL+	Power supply 24 Vdc for driver logic	Input - power supply
-	10	VL0	Power supply 0 Vdc for driver logic	Gnd - power supply
-	11	FAULT	Fault (0V) or normal working (24V)	Output - on/off signal
G	PE	EARTH	Internally connected to the driver housing	

Note: A minimum time of 300 to 500 ms have be considered between the driver energizing with the 24 Vdc power supply and when the valve is ready to operate. During this time the current to the valve coils is switched to zero.

9.2 ELECTRONIC CONNECTIONS - 5 PIN COMMUNICATION CONNECTORS

PIN	-PS Serial		-BC CANopen		-BP PROFIBUS DP	
	SIGNAL	TECHNICAL SPECIFICATION	SIGNAL	TECHNICAL SPECIFICATION	SIGNAL	TECHNICAL SPECIFICATION
1	NC	do not connect	CAN_SHLD	Shield	+5V	for termination
2	NC	do not connect	NC	do not connect	LINE-A	Bus line (high)
3	RS_GND	Signal zero data line	CAN_GND	Signal zero data line	DGND	data line and termination Signal zero
4	RS_RX	Valves receiving data line	CAN_H	Bus line (high)	LINE-B	Bus line (low)
5	RS_TX	Valves transmitting data line	CAN_L	Bus line (low)	SHIELD	

10 SOFTWARE TOOLS

The driver configuration and parameters can be easily set with the Atos E-SW programming software, available in three different versions according to the driver's communication execution: E-SW-PS (Serial), E-SW-BC (CANopen) and E-SW-BP (PROFIBUS DP).

For a more detailed description of software interface, PC requirements, adapters, cables and terminators, please refer to technical table G500.

Programming software, must be ordered separately:

E-SW-* (mandatory - first supply) = Dvd including E-SW-^{*} software installer and operator manuals; it allows the registration to Atos digital service

E-SW-^{*}-N (optional - next supplies) = as above but not allowing the registration to Atos digital service

On first supply of the E-SW-^{*} software, it is required to apply for the registration in the Atos download area: www.download.atos.com.

Once the registration is completed, the password will be sent by email.

The software remains active for 10 days from the installation date and then it stops until the user inputs his password.

With the password you can also download, in your personal area, the latest releases of the Atos software, manuals, drivers and configuration files.

11 MAIN CHARACTERISTICS OF PROPORTIONAL THROTTLE CARTRIDGE VALVES

Assembly position	Any position
Subplate surface finishing	Roughness index Ra 0,4 - flatness ratio 0,01/100 (ISO 1101)
Ambient temperature	-20°C ÷ +70°C for -T execution; -20°C ÷ +60°C for -TE and TES executions
Fluid	Hydraulic oil as per DIN 51524 ... 535 for other fluids see section I
Recommended viscosity	15 ÷ 100 mm ² /s at 40°C (ISO VG 15÷100)
Fluid contamination class	ISO 4406 class 20/18/15 NAS 1638 class 9, in line filters of 10 μm (β ₁₀ ≥75 recommended)
Fluid temperature	-20°C +60°C (standard seals and water glycol) -20°C +80°C (/PE seals)
Coil resistance R at 20°C	3 ÷ 3,3 Ω
Max. solenoid current	2,6 A
Max. power	35 Watt
Insulation class	H (180°) Due to the occurring surface temperatures of the solenoid coils, the European standards ISO 13732-1 and EN982 must be taken into account
Protection degree (CEI EN-60529)	IP65 for -T execution; IP67 for -TE and TES executions
Duty factor	Continuous rating (ED=100%)

12 DIAGRAMS (based on mineral oil ISO VG 46 at 50 °C)

12.1 Regulation diagrams, see note

- 1 = LIQZO-T*-162L4
- 2 = LIQZO-T*-252L4

12.2 Bode diagrams

stated at nominal hydraulic conditions

- 3 = LIQZO-T*-162L4: 10% ÷ 90%
- 4 = LIQZO-T*-162L4: 50% ± 5%
- 5 = LIQZO-T*-252L4: 10% ÷ 90%
- 6 = LIQZO-T*-252L4: 50% ± 5%

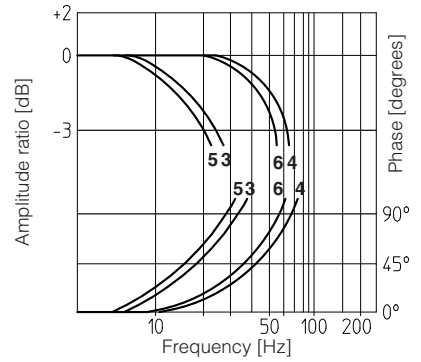
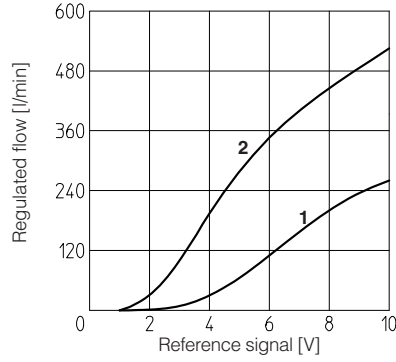

12.3 Regulation diagrams, see note

- 1 = LIQZO-T*-322L4

12.4 Bode diagrams

stated at nominal hydraulic conditions

- 2 = LIQZO-T*-322L4: 10% ÷ 90%
- 3 = LIQZO-T*-322L4: 50% ± 5%

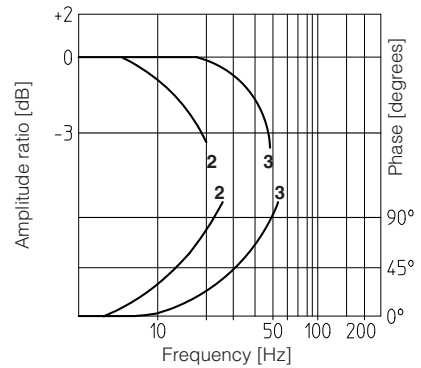
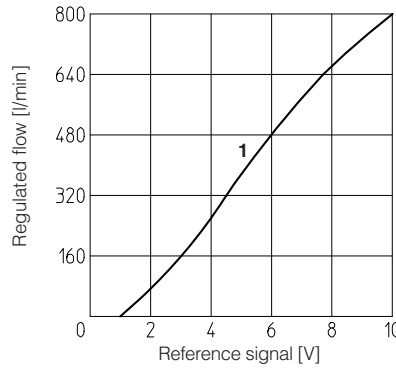

12.5 Regulation diagrams, see note

- 1 = LIQZO-T*-402L4

12.6 Bode diagrams

stated at nominal hydraulic conditions

- 2 = LIQZO-T*-402L4: 10% ÷ 90%
- 3 = LIQZO-T*-402L4: 50% ± 5%

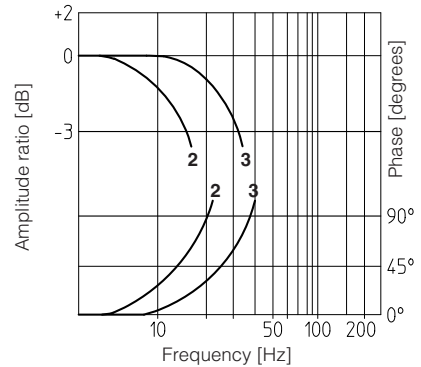
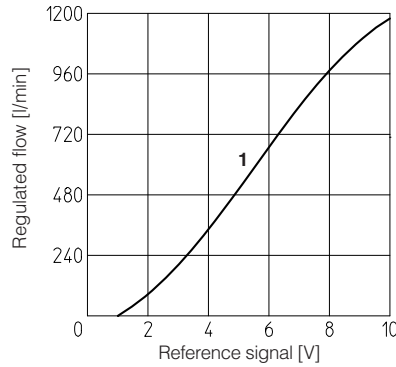

12.7 Regulation diagrams, see note

- 1 = LIQZO-T*-502L4

12.8 Bode diagrams

stated at nominal hydraulic conditions

- 2 = LIQZO-T*-502L4: 10% ÷ 90%
- 3 = LIQZO-T*-502L4: 50% ± 5%

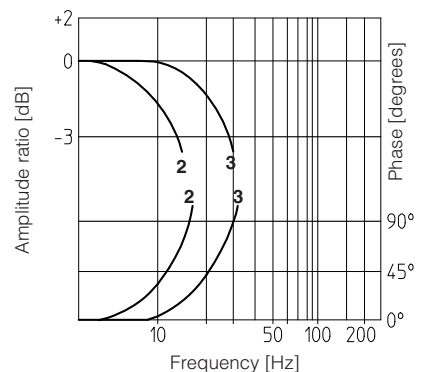
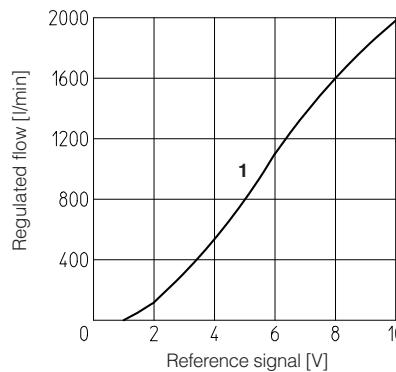

Note:

For the valves with digital electronics, the regulation characteristic can be modified by setting the internal software parameters, see tab. G500.

12.9 Dynamic response

The response times in section 3 and the frequency responses of the bode diagrams in sections 12.2, 12.4, 12.6, 12.8, have to be considered as average values. For the valves with digital electronics the dynamics performances can be optimized by setting the internal software parameters.

13 ADDITIONAL EXTERNAL PILOT PORT CONNECTION

Sizes 16 - 50

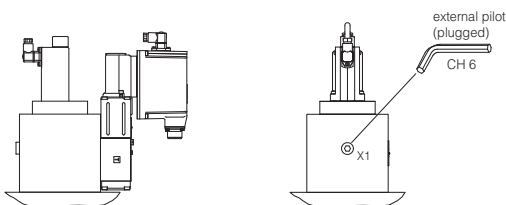

X1 = additional external pilot port connection G1/4"

14 INSTALLATION DIMENSIONS [mm]

Size 16, 25, 32, 40

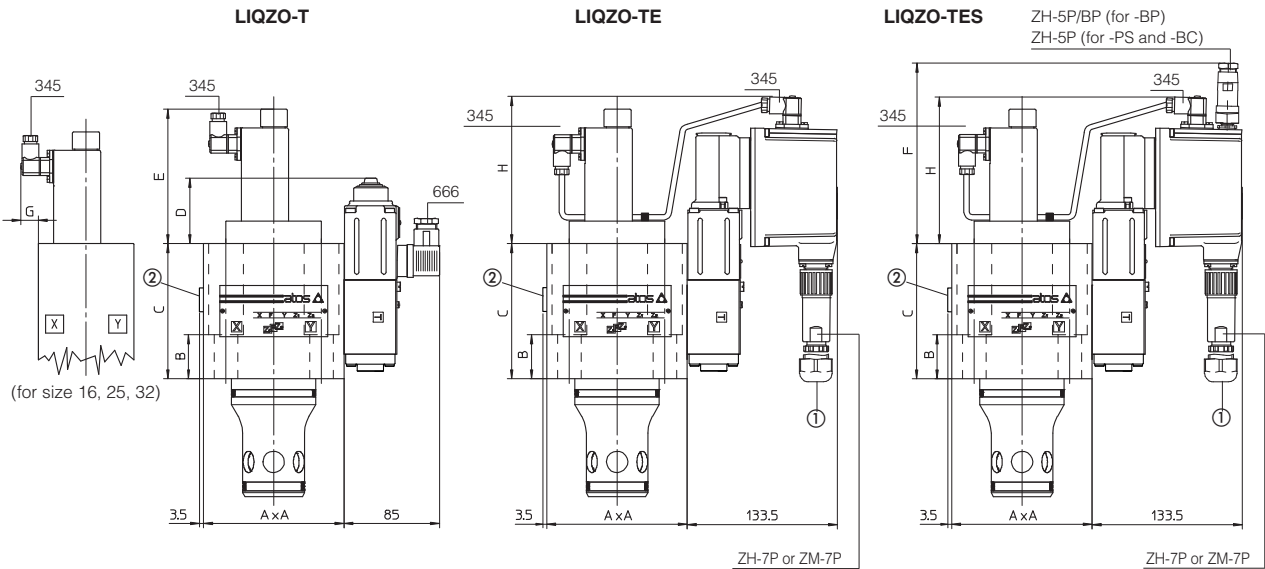

Size 50

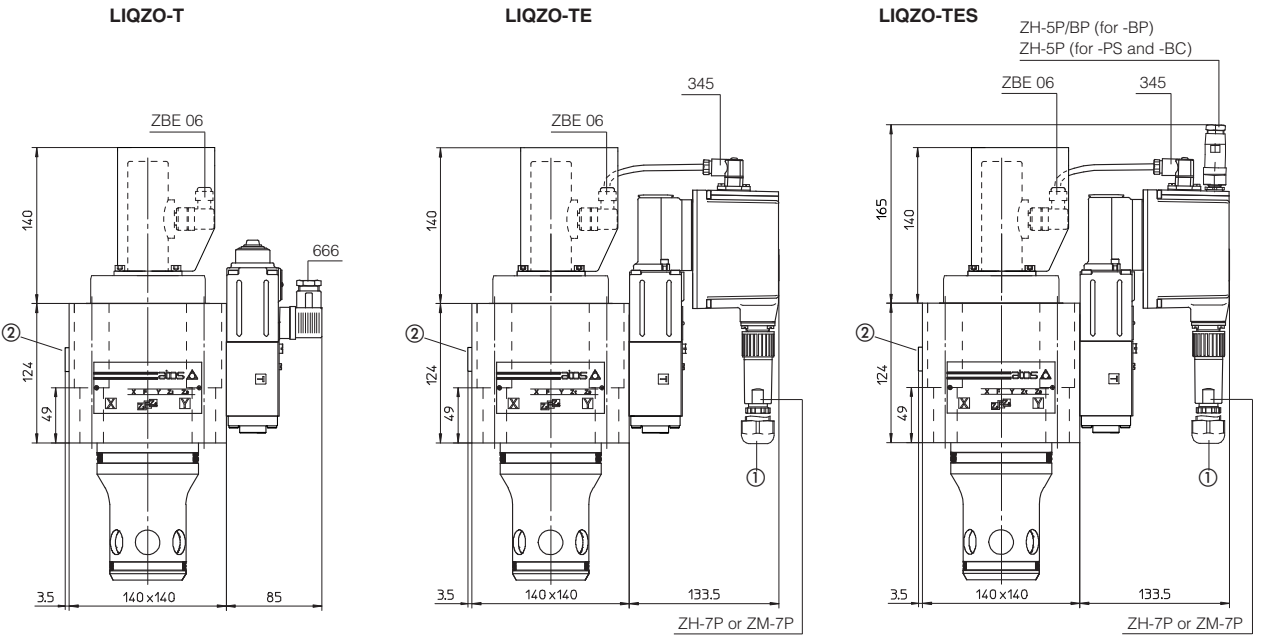

Size	A	B	C	D	E	F (TES)	G	H	Fastening bolts class 12.9	Tightening torque	Weight (Kg)	T	TE-TES
16	65	75	98	80	100	178	25	150	N°4 M8x90	35 Nm	5,2	5,8	
25	85	80	95	79	114	182	16	150	N°4 M12x100	125 Nm	7,5	8,1	
32	100	30	105	72	121	171	7	145	N°4 M16x90	300 Nm	10,2	10,8	
40	125	39	120	58	120	157	-	130	N°4 M20x70	600 Nm	16	16,6	
50	see drawing						-	135	N°4 M20x80	600 Nm	23,2	23,8	

-TE and -TES EXECUTION

① Dotted line = 12 pin connector ZH-12P for option /Z

-ALL EXECUTIONS

② External piloting X1 = G1/4

Mounting surface and cavity: ISO 7368
(see table P006)

15 MODEL CODES OF POWER SUPPLY AND COMMUNICATION CONNECTORS (to be ordered separately)

VALVE VERSION	-T			-TE, -TES		-TE/Z -TES /Z	serial (-PS) or CANopen (-BC)	PROFIBUS DP (-BP)
	Power supply	Transducer						
CONNECTOR CODE	666	345	ZBE 06	ZH-7P	ZM-7P	ZH-12P	ZH-5P	ZH-5P/BP
PROTECTION DEGREE	IP65	IP65	IP67	IP67	IP67	IP67	IP67	IP67
DATA SHEET	K500			G200, G210, K500			G210, K500	

connectors supplied with the valve