

# Modular cartridge valves type LIM, LIR, LIC

Pressure controls: relief, reducing, compensator, ISO 7368 size from 16 to 80

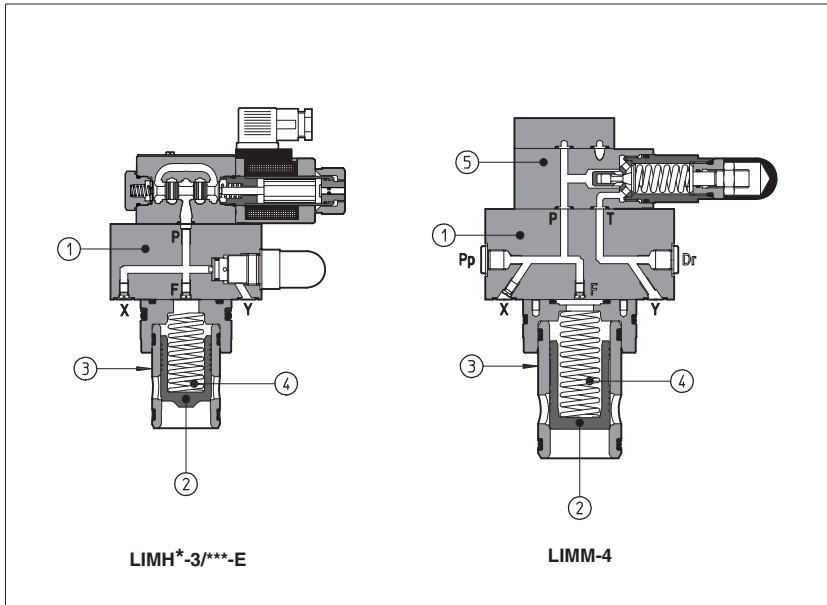

LIM, LIR and LIC are pressure control valves composed by a 2-way cartridge housed in a standard recess and by a functional "cover" ①.

The cartridge is composed by a poppet ② hydraulically piloted by means of internal connections in the cover (X, F, Y) and sliding into a drilled sleeve ③; cracking pressure value depends on poppet spring ④.

Pressure relief valve ⑤ with manual setting is housed in the cover for sizes 16, 25 and 32 and is mounted on the cover for sizes 40...80.

Poppets may have different geometrical shapes and area ratios as described in section ⑤ to optimize the control.

These valves are available in standard sizes 16 to 80 according to ISO 7368 (DIN 24342).

Flow up to 5400 l/min at  $\Delta p = 6$  bar.  
Pressure up to 350 bar.

## 1 MODEL CODE FOR COVERS

LI	MHA	-1	/210	/V	- I	X	24DC	**	/*	F**
Cover according to ISO 7368										
<p>MM = pressure relief control with manual setting;                      MHA = pressure relief control with solenoid valve for venting. Unloading when solenoid is deenergized;                      MHC = pressure relief control with solenoid valve for venting. Unloading when solenoid is energized;                      RA = pressure reducing control with manual setting. Open in resting position;                      C = pressure compensator to be coupled with flow control valves;                      CM = pressure compensator with mechanical max pressure regulation to be coupled with flow control valves.</p>										
<p>Size: 1 = 16; 2 = 25; 3 = 32; 4 = 40;                      5 = 50; 6 = 63; 8 = 80                      LIRA is available only in size 16, 25, 32, 40</p>										
<p>Pressure range:                      50 = 6 ÷ 50 bar; 210 = 10 ÷ 210 bar;                      100 = 8 ÷ 100 bar; 350 = 15 ÷ 350 bar</p>										
<p>For model code of poppet, see section ④</p>										
<p>Optional different provision or setting of the calibrated plugs in the pilot channels, see section ⑦</p>										
<p>Seals material:                      omit for NBR (mineral oil &amp; water glycol)                      PE = FPM</p>										
<p>Series number</p>										
<p>Voltage code (only for LIMH*), see section ⑧                      00 = valve without coils (only for OI solenoid)</p>										
<p>Only for LIMH*                      X = without connector                      See section ⑧ for available connectors, to be ordered separately</p>										
<p>Pilot valve (only for LIMH*):                      -I = DHI for AC and DC supply, with cURus certified solenoids                      -E = DHE for AC and DC supply, high performances                      -ER = DHER as DHE but with cURus certified solenoids</p>										
<p>Options: see section ⑦</p>										

## 2 HYDRAULIC SYMBOLS

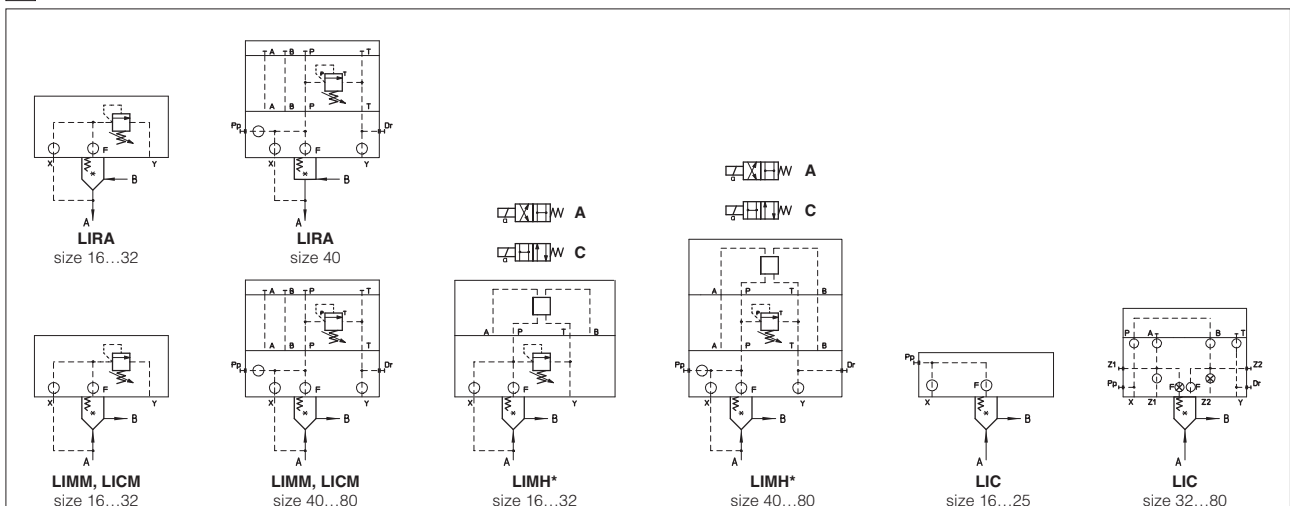

### 3 HYDRAULIC CHARACTERISTICS

Cover, see section 1	LIMM, LIMHA, LIMHC								LIRA				LIC, LICM							
	31 (1), 34 (2), 35 (3)								37				31, 36							
Poppet, see section 4, 5																				
Size	16	25	32	40	50	63	80	16	25	32	40	16	25	32	40	50	63	80		
Max flow at $\Delta p = 6$ bar [l/min]	200	400	670	1200	2200	3500	5400	160	270	540	840	200	400	670	1200	2200	3500	5400		
Max pressure [bar]	350 bar at ports A, B, X; 160 bar at port Y																			

(1) Size 80 is available only for poppet 31; (2) Poppet 34 is available only in size 16; (3) Poppet 35 is available only in size 16...50;

### 4 MODEL CODE FOR POPPET, see section 4 for functions

SC	LI	-	16	31	2	**	/*
Cartridge according to ISO 7368							
Size, the same of relevant cover: <b>16</b> = 16; <b>32</b> = 32; <b>50</b> = 50; <b>80</b> = 80 <b>25</b> = 25; <b>40</b> = 40; <b>63</b> = 63;							
Type of poppet, see section 3 for maximum flow: <b>31</b> = (sizes 16...80) = for LIMM, LIMH*, LIC, LICM <b>34</b> = (size 16) = for LIMM, LIMH* <b>35</b> = (sizes 16...50) = for LIMM, LIMH* <b>36</b> = (sizes 16...80) = for LIC, LICM <b>37</b> = (sizes 16...40) = for LIRA							
Series number						Seals material: omit for NBR (mineral oil & water glycol) <b>PE</b> = FPM	
Spring cracking pressure: <b>1</b> = 0,3 bar for poppet 35; <b>4</b> = 4 bar for poppet 37; <b>2</b> = 1,2 bar for poppet 31, 34, 35; <b>6</b> = 6 bar for poppet 31, 34, 35, 36; <b>3</b> = 3 bar for poppet 31, 34, 35; <b>7</b> = 7 bar for poppet 37 (not available for size 40);							

### 5 TYPICAL FUNCTIONS OF POPPETS

Code of poppet	31	34	35	36	37
Functional sketch (Hydraulic symbol)					
Typical section					
Area ratio (1)	1:1	1:1	1:1,1	1:1	1:1

(1) It is the ratio of the area on which the main pressure of the circuit is applied to the area on which the pilot pressure is applied.

### 6 MAIN CHARACTERISTICS OF MODULAR PRESSURE CONTROL CARTRIDGE VALVES TYPE LIMM, LIMH\*, LIRA, LIC\*

Assembly position / location	Any position
Subplate surface finishing	Roughness index Ra 0,4 - flatness ratio 0,01/100 (ISO 1101)
Ambient temperature	-20°C to +70°
Fluid	Hydraulic oil as per DIN 51524 . . . 535; for other fluids see section 1
Recommended viscosity	15 ÷ 100 mm <sup>2</sup> /s at 40°C (ISO VG 15 ÷ 100)
Fluid contamination class	ISO 4406 class 21/19/16 NAS 1638 class 10, in line filters of 25 µm (β <sub>25</sub> ≥ 75 recommended)
Fluid temperature	-20°C +60°C (standard seals and water glycol) -20°C +80°C (/PE seals)

#### 6.1 Coils characteristics

Insulation class	H (180°C) Due to the occurring surface temperatures of the solenoid coils, the European standards EN563 and EN982 must be taken into account
Connector protection degree	IP 65
Relative duty factor	100%
Supply voltage and frequency	See electric feature 9
Supply voltage tolerance	± 10%

### 7 OPTIONS

Only for LIMM (size 16...32):

- /P** = predisposed for ISO 4401 size 06 mounting surface
- Handwheel for pressure control, only for LIMM, LIMH\*, LIRA, LICM (see section 13 for dimensions):
- /V** = regulating handwheel (available for all the sizes)
- /VF** = regulating knob (available only for sizes 40...80)
- /VS** = manual override with safety locking (available only for sizes 40...80)
- Handwheel for OI solenoid pilot valve, only for LIMH\*:
- /WP** = prolonged manual override protected by rubber cap (see table K150).

For all the models:

- \*\*\*** = calibrated plugs different from standard one. All covers contain and are equipped with restrictors in the pilot channels according to the standard arrangement which is preset for each variant (see section 14). They can be exchanged with others for particular use. When ordering covers equipped with restrictors that are different from the standard ones it must be indicated at the end of the model code:

**LIMHA - 1 /210 -IX 24DC \*\* F 06**

Channel where the orifice has to be provided:  
**X** = channel X  
**F** = channel F

Size of the throttling hole in ten of millimeters:  
**05** = 0,5 mm    **10** = 1 mm  
**06** = 0,6 mm    **12** = 1,2 mm  
**08** = 0,8 mm    **15** = 1,5 mm

Note:

DHI, DHE and DHER solenoid pilot valves can be provided with the following handwheel (see table K150):

**WPD/H** (for DHI), **WPD/HS** (for DHE) = manual override with detent, to be ordered separately.

Covers type LIMH\* can also be equipped with the following pilot solenoid valves.

- AO** = explosion-proof solenoid according to ATEX Norm (see table E120 for technical characteristics)
- AO/E** = explosion-proof solenoid according to IECEx Norm (see table E120 for technical characteristics)
- AO/RU** = explosion-proof solenoid according to ROSTECHNADZOR Russian Certification (see table E120 for technical characteristics)
- AO/UL** = explosion-proof solenoid according to UL Norm (see table E125 for technical characteristics)
- WO** = intrinsically safe solenoid according to ATEX (see table E130 for technical characteristics)

## 8 DIAGRAMS OF POPPETS

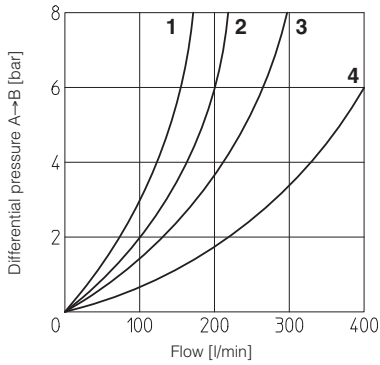

1 = SC LI-1637    3 = SC LI-2537  
                   -1631                   -2531  
 2 = SC LI-1634    4 = SC LI-2535  
                   -1635                   -2536  
                   -1636

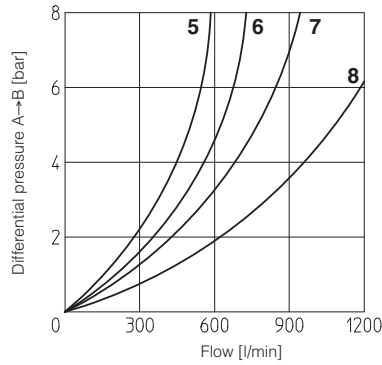

5 = SC LI-3237    7 = SC LI-4037  
                   -3231                   -4031  
 6 = SC LI-3235    8 = SC LI-4035  
                   -3236                   -4036

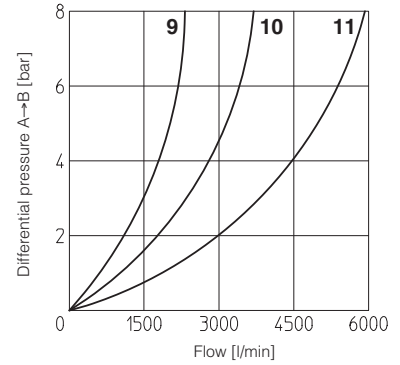

                                  -5031  
 9 = SC LI-5035    11 = SC LI-8031  
                                   -5036                   -8036  
 10 = SC LI-6331  
                                   -6336

## 9 ELECTRIC FEATURES

Solenoid valve type	External supply nominal voltage ± 10% (1)		Voltage code	Type of connector	Power consumption (3)	Code of spare coil DHI	Colour of coil label DHI	Code of spare coil DHE	Code of spare coil DHER
DHI DHE DHER	DC	12 DC	<b>12 DC</b> <b>24 DC</b> <b>110 DC</b> <b>220 DC</b>	666 or 667	33 W (DHI) 30 W (DHE, DHER)	COU-12DC /80 COU-24DC /80 COU-110DC /80 COU-220DC /80	green red black black	COE-12DC/10 COE-24DC/10 COE-110DC/10 COE-220DC/10	COER-12DC/10 COER-24DC/10 COER-110DC/10 COER-220DC/10
		24 DC							
AC	110/50 AC (2)	<b>110/50/60 AC</b> <b>115/60 AC (5)</b> <b>120/60 AC (6)</b> <b>230/50/60 AC</b> <b>230/60 AC</b>		666 or 667	60 VA (DHI) 58 VA (DHE, DHER) (4)	COI-110/50/60AC /80 - COI-120/60AC /80 COI-230/50/60AC /80 COI-230/60AC /80	yellow - white light blue silver	COE-110/50/60AC/10 COE-115/60AC/10 - COE-230/50/60AC/10 COE-230/60AC/10	COER-110/50/60AC/10 COER-115/60AC/10 - COER-230/50/60AC/10 COER-230/60AC/10
	115/60 AC								
120/60 AC									
230/50 AC (2) 230/60 AC									

- (1) For other supply voltages available on request see technical tables E010, E015.
- (2) Coil can be supplied also with 60 Hz of voltage frequency; in this case the performances are reduced by 10 - 15% and the power consumption is 55 VA (DHI) and 58 VA (DHER)
- (3) Average values based on tests performed at nominal hydraulic condition and ambient/coil temperature of 20°C.
- (4) When solenoid is energized, the inrush current is approx 3 times the holding current. Inrush current values correspond to a power consumption of about 150 VA.
- (5) Only for DHE and DHER
- (6) Only for DHI

## 10 RECESS DIMENSIONS [mm]

Sizes	Ø d1	Ø d2	Ø d3 max	Ø d4 max	L1	L2	L3	L4 max	L5	L6	L7	U	W
16	32	25	16	22,5	43 <sup>+0,1</sup> <sub>0</sub>	56 <sup>+0,1</sup> <sub>0</sub>	54	42,5	20	2	2	0,03	0,05
25	45	34	25	27	58 <sup>+0,1</sup> <sub>0</sub>	72 <sup>+0,1</sup> <sub>0</sub>	70	57	30	2,5	2,5	0,03	0,05
32	60	45	32	38,5	70 <sup>+0,1</sup> <sub>0</sub>	85 <sup>+0,1</sup> <sub>0</sub>	83	68,5	30	2,5	2,5	0,03	0,1
40	75	55	40	54,5	87 <sup>+0,1</sup> <sub>0</sub>	105 <sup>+0,1</sup> <sub>0</sub>	102	84,5	30	3	3	0,05	0,1
50	90	68	50	62,5	100 <sup>+0,1</sup> <sub>0</sub>	122 <sup>+0,1</sup> <sub>0</sub>	117	97,5	35	3	3	0,05	0,1
63	120	90	63	87	130 <sup>+0,1</sup> <sub>0</sub>	155 <sup>+0,1</sup> <sub>0</sub>	150	127	40	4	4	0,05	0,2
80	145	110	80	100	175 <sup>+0,2</sup> <sub>0</sub>	205 <sup>+0,2</sup> <sub>0</sub>	200	170,5	40	5	5	0,05	0,2

## 11 COVER INTERFACE DIMENSIONS [mm]

Sizes	A	B	C	D	E	F	G	J min	K	L min	M	Ø N	P max	R	S max
16	2	12,5	23	46	48	46	23	-	-	65	M8	4	4	22	8
25	4	13	29	58	62	58	29	-	-	85	M12	6	6	30	8
32	6	18	35	70	76	70	35	-	-	102	M16	6	8	38	8
40	7,5	19,5	42,5	85	92,5	85	42,5	-	-	125	M20	6	10	46	8
50	8	20	50	100	108	100	50	-	-	140	M20	8	10	46	8
63	12,5	24,5	62,5	125	137,5	125	62,5	-	-	180	M30	8	12	66	8
80	-	-	-	-	-	-	-	250	200	-	M24	10	16	50	8

12 COVER DIMENSIONS [mm]

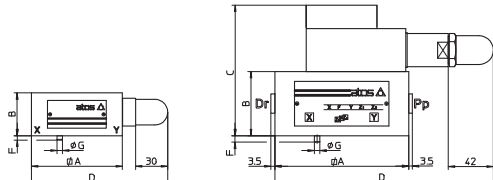

Covers	A	B	C	D	F	G	Port Pp-Dr	Seals	Fastening bolts (2)	Tightening torque (Nm)	Weight (Kg)
LIMM-1 LIRA-1 LICM-1	65	40	-	107,5	4	3	-	2 OR 108	Nr. 4 M8x45	35	1,7
LIMM-2 LIRA-2 LICM-2	85	40	-	127,5	6	5	-	2 OR 108	Nr. 4 M12x45	125	2,2
LIMM-3 LIRA-3 LICM-3	100	50	-	142,5	6	5	-	2 OR 2043	Nr. 4 M16x55	300	3,5
LIMM-4 LIRA-4 LICM-4	125	60	122	195	6	5	G 1/4	2 OR 2050	Nr. 4 M20x70	600	8,9
LIMM-5 LICM-5	140	70	132	202,5	4	6	G 1/4	2 OR 2050	Nr. 4 M20x80	600	12,4
LIMM-6 LICM-6	180	80	142	222,5	4	6	G 3/8	2 OR 2056	Nr. 4 M30x90	2100	21,6
LIMM-8 LICM-8	∅250	80	172	257,5	6	8	G 3/8	2 OR 123	Nr. 8 M24x90	1000	30,5

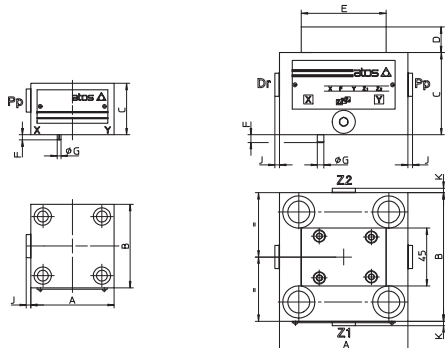

Covers	A	B	C	D	E	F	G	K	J	Port Pp-Dr	Port Z1-Z2	Seals	Fastening bolts (2)	Tightening torque (Nm)	Weight (Kg)
LIC-1	65	65	40	-	-	4	3	-	3,5	G 1/4	-	2 OR 108	Nr. 4 M8x45	35	1,4
LIC-2	85	85	40	-	-	6	5	-	3,5	G 1/4	-	2 OR 108	Nr. 4 M12x45	125	1,8
LIC-3	100	100	50	20	66	6	5	-	3,5	G 1/4	-	4 OR 2043	Nr. 4 M16x55	300	2,3
LIC-4	125	125	60	20	66	6	5	-	3,5	G 1/4	-	4 OR 2050	Nr. 4 M20x70	600	6,2
LIC-5	140	140	70	20	66	4	6	3,5	3,5	G 1/4	G 1/4	4 OR 2050	Nr. 4 M20x80	600	9,3
LIC-6	180	180	80	20	66	4	6	3,5	3,5	G 3/8	G 3/8	4 OR 2056	Nr. 4 M30x90	2100	17,1
LIC-8	∅ 250	-	80	30	73	6	8	-	3,5	G 3/8	-	4 OR 123	Nr. 8 M24x90	1000	27

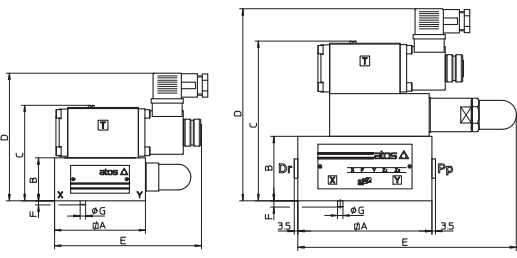

Covers	A	B	C max	D max	E	F	G	Port Pp-Dr	Seals	Fastening bolts (2)	Tightening torque (Nm)	Weight (Kg)
LIMHA-1 LIMHC-1	65 (1)	40	87,5	123,5	124,5	4	3	-	2 OR 108	Nr. 4 M8x45	35	3
LIMHA-2 LIMHC-2	85	40	87,5	123,5	134,5	6	5	-	2 OR 108	Nr. 4 M12x45	125	3,3
LIMHA-3 LIMHC-3	100	50	130,5	153,5	142,5	6	5	-	2 OR 2043	Nr. 4 M16x55	300	5
LIMHA-4 LIMHC-4	125	60	150,5	183,5	195	6	5	G 1/4	2 OR 2050	Nr. 4 M20x70	600	9,2
LIMHA-5 LIMHC-5	140	70	160,5	193,5	202,5	4	6	G 1/4	2 OR 2050	Nr. 4 M20x80	600	13,2
LIMHA-6 LIMHC-6	180	80	170,5	203,5	222,5	4	6	G 3/8	2 OR 2056	Nr. 4 M30x90	2100	22,5
LIMHA-8 LIMHC-8	∅ 250	80	200,5	233,5	257,5	6	8	G 3/8	2 OR 123	Nr. 8 M24x90	1000	31,3

(1) Cover is not squared: 65x80  
(2) Hexagon socket head screw according to DIN 912 class 12.9

Overall dimensions refer to the pilot valves with connectors type 666

13 HANDWHEELS FOR PRESSURE PILOT VALVES: DIMENSIONS [mm]

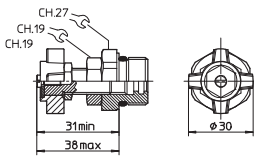
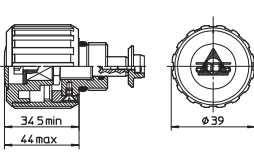
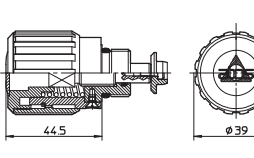
	IV	IVF	IVS
Options			

14 SCREWED ORIFICES IN STANDARD COVER EXECUTION: DIMENSIONS (1)

Port	Cover																											
	LIM*-1	LIRA-1	LICM-1	LIC-1	LIM*-2	LIRA-2	LICM-2	LIC-2	LIM*-3	LIRA-3	LICM-3	LIC-3	LIM*-4	LIRA-4	LICM-4	LIC-4	LIM*-5	LICM-5	LIC-5	LIM*-6	LICM-6	LIC-6	LIM*-8	LICM-8	LIC-8			
X	M4 10A	M4 08A	M4 08A	-	M4 10A	M4 08A	M4 08A	-	M6 10A	M6 08A	M6 12A	M6 10A	M6 10A	M6 12A	M6 10A	M6 10A	M6 10A	M6 10A	M6 10A	M6 10A	M6 10A	M6 10A	M8 10A	M8 10A	M8 10A			
F	M4 12F	M4 12A	M4 05F	M4 05F	M4 12F	M4 12A	M4 05F	M4 05F	M6 12F	M6 12A	M6 12F	M6 05F	M6 12F	M6 08A	M6 12F	M6 12F	M6 12F	M6 12F	M6 12F	M6 12F	M6 12F	M6 12F	M8 12F	M8 12F	M8 12F			

(1) The showed codes define the orifice thread, diameter of the throttling hole in ten of millimeters and the form of throttle sectional area:  
A = variable sectional area; F = constant sectional area