

# Proportional directional valves type DPZO-TES

two stage, with position transducer, ISO 4401 sizes 10, 16, 25 and 32

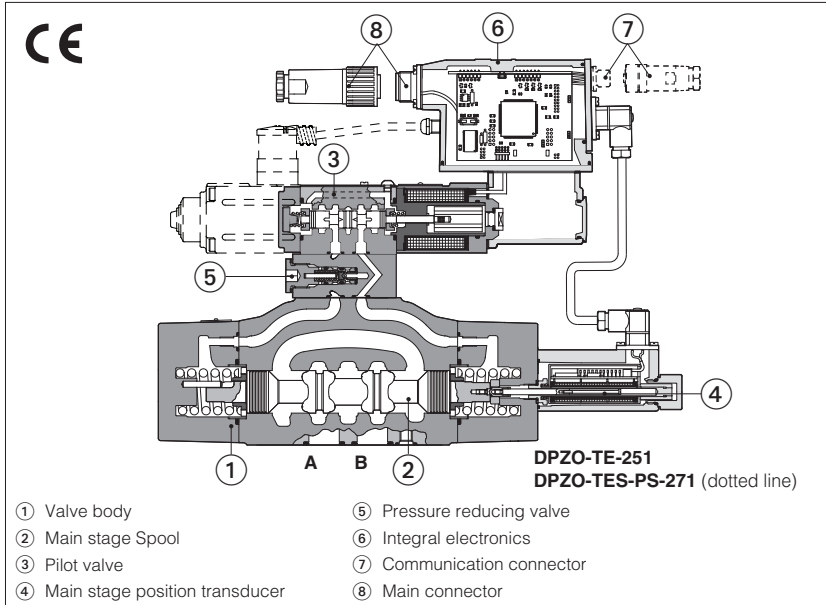

## 1 MODEL CODE

**DPZO -TES -PS - 2 7 1 - L 5 / \* / \*\* / \***

Piloted proportional directional valve  <b>T</b> = with position transducer <b>TE</b> = as T plus integral analog electronics <b>TES</b> = as T plus integral digital electronics  Communication interfaces (only for TES) <b>PS</b> = RS232 serial <b>BC</b> = CANbus <b>BP</b> = PROFIBUS-DP  Valve size: <b>1</b> = 10; <b>2</b> = 16; <b>3</b> = 25; <b>4</b> = 25 (high flow) <b>6</b> = 32  Configuration, see section 3 <b>5</b> = external plus central position, spring centered <b>7</b> = 3 position, spring centered  Spool overlapping in central position, see section 3 <b>1</b> = P, A, B, T with positive overlapping (1) <b>3</b> = P positive overlapping (1); A, B, T, negative overlapping  Spool type (regulating characteristics): <b>L</b> = linear; <b>S</b> = progressive; <b>D</b> = differential-progressive (as <b>S</b> , but with P-A = Q, P-B = Q/2) <b>DL</b> = differential-linear (as <b>L</b> , but with P-A = Q, P-B = Q/2) <b>Q</b> = linear spool, for alternate P/Q controls (2) <b>V</b> = differential-progressive, for alternate P/Q controls (2)  Spool size: <b>3, 5, 9</b> see section 3	Seals material: omit for NBR (mineral oil & water glycol) <b>PE</b> = FPM  Series number	<b>Hydraulic options</b> , see section 4: <b>B</b> = solenoid, integral electronics and position transducer at side of port A of the main stage <b>E</b> = external pilot (through port X) <b>D</b> = internal drain  <b>Electronic options for -TE execution</b> see section 7: <b>F</b> = fault signal <b>I</b> = current reference input and monitor (4÷20 mA) <b>Q</b> = enable signal <b>Z</b> = enable, fault and monitor signal (12 pin connector)  <b>Electronic options for -TES execution</b> see section 7: <b>I</b> = current reference input and monitor (4÷20 mA) <b>Z</b> = double power supply, enable, fault and monitor signals (12 pin connector)  <b>Special options for -TES execution</b> see section 7: <b>SF</b> = additional closed loop force control, with two remote pressure transducers <b>SL</b> = additional closed loop force control with one remote load cell <b>SP</b> = additional closed loop pressure control with one remote pressure transducer <b>C</b> = current feedback interface for transducer(s) <b>only for options /SF, /SL, /SP</b>
---	--	---

### Notes:

- (1) Overlapping = 20% of spool stroke for type **S, D** and **Q**; 10% of spool stroke for type **L** and **DL**
- (2) The spools type **Q** and **V** are specific for alternate P/Q controls and they can be used in combination with option /S\* of digital integral drivers (see section 13.1 and G212), or digital position controllers type Z-RI-TEZ (see tab. G330) or Z-ME-KZ (see tab. G340)

## 2 ELECTRONIC DRIVERS

Valve model	-T	-TE	-TES	-TES / SF, SL, SP
Drivers model	E-ME-T	E-RI-TE	E-RI-TES	E-RI-TES/SF, /SL, /SP
Data sheet	G140	G200	G210	G212

**Note:** For power supply and communication connector see section 16

DPZO-T\* are two stage proportional valves with position transducer on the main spool which provide both directional and non compensated flow control according to electronic reference signal.

They operate in association with electronic drivers, see section 2, which supply the proportional valves with proper current to align valve regulation to the reference signal supplied to the electronic driver.

- They are available in different executions:
- -T, with position transducers ④;
  - -TE, -TES as -T plus analog (TE) or digital (TES) integral electronics ⑥.

The 4-way spool ②, sliding into a 5-chambers body ①, is piloted by a proportional directional valve ③ type DHZO (see tab. F160) and it is controlled in closed loop position by means of the LVDT transducer ④.

The pressure reducing valve ⑤ with fixed setting ensures a constant piloting pressure.

The integral electronics ⑥ ensures factory presetting, fine functionality plus valve-to-valve interchangeability and simplified wiring and installation. The electronic main connector ⑧ is fully interchangeable for -TE and -TES executions.

Standard 7 pin main connector is used for power supply, analog input reference and monitor signals.

12 pin connector is used for options /Z and /S\*.

The special /S\* options add a closed loop control of pressure (/SP) or force (/SF and /SL) to the basic closed loop spool position one.

Following communication interfaces ⑦ are available for the digital -TES execution:

- -PS, Serial communication interface for configuration, monitoring and firmware updating through Atos PC software
- -BC, CANopen interface
- -BP, PROFIBUS DP interface

The valves with -BC and -BP interfaces can be integrated into a fieldbus communication network and thus digitally operated by the machine control unit.

The coils are fully plastic encapsulated (insulation class H) and the valves have antivibration, antishock and weather-proof features.

Mounting surface: ISO 4401 sizes 10, 16, 25 and 32.

Max flow respectively up to 160 l/min, 430 l/min, 680 l/min, 730 l/min and 1100 l/min with valve differential pressure  $\Delta p = 30$  bar, see table 2.

Max pressure: 350 bar.

**3 HYDRAULIC CHARACTERISTICS OF STANDARD SPOOL** (based on mineral oil ISO VG 46 at 50 °C) (3)

Standard spools - hydraulic symbols																			
Valve model	DPZO-T*-1				DPZO-T*-2				DPZOT*-3				DPZO-T*-4			DPZO-T*-6			
Spool overlapping	1, 3																		
Spool type and size	L5	S5	D5	DL5	L3	S3	D3	DL3	L5	S5	D5	DL5	L5	S5	D5	DL5	L5	S5	D5
Max flow (1): [l/min]	at Δp = 10 bar																		
	100	100:60	160	160:98	250	225	225:160	250:188	390	360	360:220	390:240	420	400	400:245	420:260	640	640	640:400
	160	160:100	270	270:160	430	390	390:280	430:323	680	620	620:380	680:410	730	690	690:420	730:450	1100	1100	1100:690
	180	180:100	600	600:370	880	800	800:580	880:660	1450	1350	1350:820	1450:880	1450	1380	1380:845	1560:890	1600	1600	1600:1000
	max permissible flow																		
Specific spools - hydraulic symbols																			
Valve model	DPZO-T*-1			DPZO-T*-2			DPZOT*-3			DPZO-T*-4									
Spool overlapping	1, 3			3			1, 3			3									
Spool type and size	D9	Q5	V9	D9	L9	Q5	V9	D9	Q5	V9	D9	Q5	V9						
Max flow (1): [l/min]	at Δp = 10 bar																		
	100:60	100	250:188	250			390:240	390	420:260	420									
	160:100	160	430:323	430			680:410	680	730:450	730									
	180:110	180	880:660	880			1450:880	1450	1560:890	1560									
	max permissible flow																		
Pressure limits (2) [bar]	ports P, A, B, X = 350; T = 250 (10 for option /D); Y = 10																		
Response time (3) [ms]	< 60			< 75				< 80			< 80			< 120					
Hysteresis [%]	≤ 0,1%																		
Repeatability	± 0,5%																		
Thermal drift	zero point displacement < 1% at ΔT = 40°C																		

- Notes:**
- Above performance data refer to valves coupled with Atos electronic drivers, see section 2.
  - In case of long time shutdown of the hydraulic supply to the pilot valve, the driver has to be switched off to avoid its overheating.
  - (1) For different Δp, the max flow is in accordance to the diagrams in section 13.2
  - (2) Minimum piloting pressure = 25 bar
  - (3) 0-100% step signal

**FUNCTIONAL SCHEME**  
example of configuration 7  
(3 positions, spring centered)

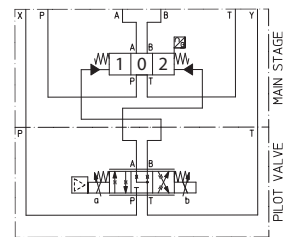

**4 HYDRAULIC OPTIONS**

- 4.1 Option /B** DPZO-\*-\*5 = solenoid, integral and position transducer at side of port A of the main stage.  
DPZO-\*-\*7 = integral electronics and position transducer at side of port A of the main stage.  
For hydraulic configuration vs. reference signal, see section 13.1
- 4.2 Pilot and drain configuration** -The pilot/drain configuration can be modified as shown in the table E085 section 10.  
The valve's standard configuration provides internal pilot and external drain. For different pilot / drain configuration select: **Option /E** External pilot (through port X). **Option /D** Internal drain.

**5 GENERAL NOTES**

DPZO-T\* proportional valves are CE marked according to the applicable Directives (e.g. Immunity/Emission EMC Directive and Low Voltage Directive). Installation, wirings and start-up procedures must be performed according to the general prescriptions shown in table F003 and in the installation notes supplied with relevant components.  
The electrical signals of the valve (e.g. monitor signals) must not be directly used to activate safety functions, like to switch-ON/OFF the machine's safety components, as prescribed by the European standards (Safety requirements of fluid technology systems and components-hydraulics, EN-982).

**6 CONNECTIONS FOR -T EXECUTION**

SOLENOID POWER SUPPLY CONNECTOR	
PIN	Signal description
1	SUPPLY
2	SUPPLY
3	GND

POSITION TRANSDUCER CONNECTOR	
PIN	Signal description
1	OUTPUT SIGNAL
2	SUPPLY -15 V <sub>dc</sub>
3	SUPPLY +15 V <sub>dc</sub>
4	GND

**7 ANALOG INTEGRAL DRIVERS -TE - OPTIONS**

Standard driver execution provides on the 7 pin main connector:

- Power supply** - 24V<sub>dc</sub> must be appropriately stabilized or rectified and filtered; a 2,5 A safety fuse is required in series to the driver power supply  
Apply at least a 10000 μF/40 V capacitance to single phase rectifiers or a 4700 μF/40 V capacitance to three phase rectifiers
- Reference input signal** - analog differential input with ±10 V<sub>dc</sub> nominal range (pin D,E), proportional to desired valve spool position
- Monitor output signal** - analog output signal proportional to the actual valve's spool position with ±10 V<sub>dc</sub> nominal range

Following options are available to adapt standard execution to special application requirements:

- 7.1 Option /F** It provides a Fault output signal in place of the Monitor output signal, to indicate fault conditions of the driver (cable interruption of spool transducers or reference signal - for /I option): Fault presence corresponds to 0 V<sub>dc</sub>, normal working corresponds to 24 V<sub>dc</sub>.
- 7.2 Option /I** It provides the 4÷20 mA current reference and monitor signals instead of the standard ±10 V<sub>dc</sub>  
It is normally used in case of long distance between the machine control unit and the valve or where the reference signal can be affected by electrical noise; the valve functioning is disabled in case of reference signal cable breakage.
- 7.3 Option /Q** It provides the possibility to enable or disable the valve functioning without cutting the power supply (the valve functioning is disabled but the driver current output stage is still active). To enable the driver supply a 24V<sub>dc</sub> on the enable input signal.
- 7.4 Option /Z** This option includes /F and /Q features, plus the Monitor output signal.  
When the driver is disabled (0 V<sub>dc</sub> on Enable signal) Fault output is forced to 0 V<sub>dc</sub>.
- 7.5 Possible combined options:** /FI and /IZ

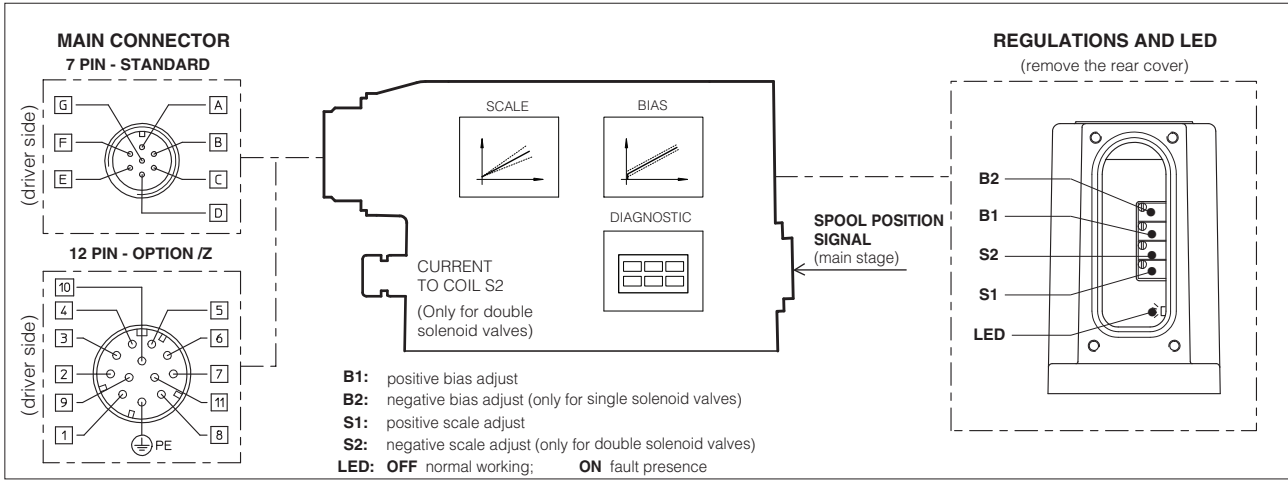

8.1 ELECTRONIC CONNECTIONS - 7 & 12 PIN MAIN CONNECTORS

Standard 7pin	/Z option 12pin	SIGNAL	TECHNICAL SPECIFICATIONS	NOTES
A	1	V+	Power supply 24 Vdc for solenoid power stage and driver logic	Input - power supply
B	2	V0	Power supply 0 Vdc for solenoid power stage and driver logic	Gnd - power supply
C (1)	7	AGND	Ground - signal zero for MONITOR signal (for standard, /Z option)	Input - analog signal
	3	ENABLE	Enable (24 Vdc) or disable (0 Vdc) the driver (for /Q and /Z options)	Input - on/off signal
D	4	INPUT+	Reference analog differential input: ±10 Vdc maximum range (4 ÷ 20 mA for /I option) For single solenoid valves the reference input is 0 ÷ +10 Vdc (4 ÷ 20 mA for /I option) For double solenoid valves the reference input is ±10 Vdc (4 ÷ 20 mA for /I option)	Input - analog signal
E	5	INPUT -		
F (2)	6	MONITOR	Monitor analog output: ±10 Vdc maximum range; (4 ÷ 20 mA for /I option)	Output - analog signal
	11	FAULT	Fault (0V) or normal working (24V) (for /F and /Z option)	Output - on/off signal
-	8	R_ENABLE	Repeat Enable - output repetition of Enable input	Output - on/off signal
-	9	NC	do not connect	Output - on/off signal
-	10	NC	do not connect	Output - on/off signal
G	PE	EARTH	Internally connected to the driver housing	

Notes:

- (1) with /Q option ENABLE signal replaces AGND on pin C; MONITOR signal is referred to pin B
- (2) with /F option FAULT signal replaces MONITOR on pin F.

- A minimum time of 50ms to 100ms have be considered between the driver energizing with the 24 Vdc power supply and when the valve is ready to operate. During this time the current to the valve coils is switched to zero.

9 DIGITAL INTEGRAL DRIVERS -TES - OPTIONS

Standard driver execution provides on the 7 pin main connector:

- Power supply** - 24Vdc must be appropriately stabilized or rectified and filtered; a 2.5 A safety fuse is required in series to each driver power supply  
 Apply at least a 10000 µF/40 V capacitance to single phase rectifiers or a 4700 µF/40 V capacitance to three phase rectifiers
- Reference input signal** - analog differential input with ±10Vdc nominal range (pin D,E), proportional to desired valve spool position
- Monitor output signal** - analog output signal proportional to the actual valve's spool position with ±10Vdc nominal range

Following options are available to adapt standard execution to application requirements:

9.1 Option /I

It provides 4÷20 mA current reference and monitor signals instead of the standard ±10 V.  
 It is normally used in case of long distance between the machine control unit and the valve or where the reference signal can be affected by electrical noise; the valve functioning is disabled in case of reference signal cable breakage.

9.2 Option /Z

It provides, on the 12 pin main connector, the following additional features:

**Logic power supply**

Separated power supply for the solenoid (pin 1, 2) and for the digital electronic circuits (pin 9, 10).  
 Cutting solenoid power supply allows to interrupt the valve functioning but keeping energized the digital electronics thus avoiding fault conditions of the machine fieldbus controller. This condition allows to realize safety systems in compliance with European Norms EN13849-1 (ex EN954-1).

**Enable Input Signal**

To enable the driver, supply 24Vdc on pin 3 referred to pin 2: when the Enable signal is set to zero the valve functioning is disabled (zero current to the solenoid) but the driver current output stage is still active.

**Fault Output Signal**

Fault output signal indicates fault conditions of the driver (solenoid short circuits/not connected, reference signal cable broken for 4÷20mA input, etc.).  
 Fault presence corresponds to 0 Vdc, normal working corresponds to 24Vdc (pin 11 referred to pin 2): Fault status is not affected by the Enable input signal

9.3 Options /SP, /SF and /SL

These options add the closed loop control of pressure (/SP) or force (/SF and /SL) to the basic functions of proportional directional valves: a dedicated software alternates pressure (force) and valve's spool position controls depending on the actual hydraulic system conditions.

A dedicated connector is available for the additional transducers that are required to be interfaced to the valve's driver (1 pressure transducer for /SP, 2 pressure transducers for /SF or 1 load cell for /SL).

Main 12 pin connector is the same as /Z option plus two analog signals specific for the pressure (force) control: one for reference (pin 7) and one for monitor (pin 8).

For further details please refer to the driver technical table G212.

9.4 Options /C

Options /CSP, /CSF and /CSL are available to connect pressure (force) transducers with 4 ÷ 20mA current output signal.

9.5 Possible combined options: /ISF, /ISL, /ISP, /CSP, /CSF, /CSL, /CISP, /CISF, /CISL and /IZ

## 10 DIGITAL INTEGRAL DRIVERS -TES - MAIN FUNCTIONS AND ELECTRONIC CONNECTIONS

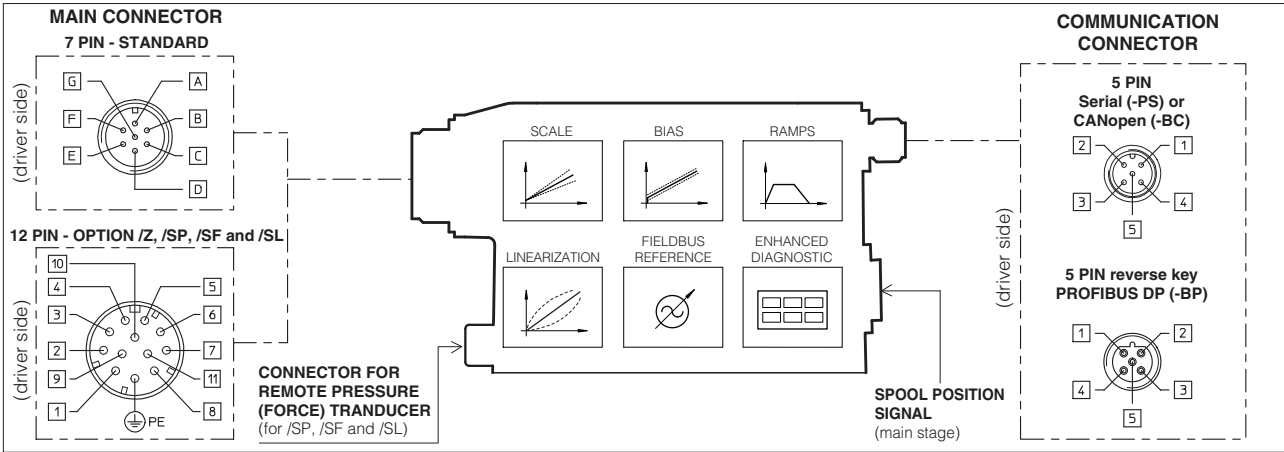

### 10.1 ELECTRONIC CONNECTIONS - 7 & 12 PIN MAIN CONNECTORS

Standard 7pin	/Z option 12pin	SIGNAL	TECHNICAL SPECIFICATIONS	NOTES
A	1	V+	Power supply 24 Vdc for solenoid power stage (and for driver logic on 7 pin connection)	Input - power supply
B	2	V0	Power supply 0 Vdc for solenoid power stage (and for driver logic on 7 pin connection)	Gnd - power supply
-	3	ENABLE	Enable (24 Vdc) or disable (0 Vdc) the driver	Input - on/off signal
D	4	INPUT+	Reference analog input: $\pm 10$ Vdc maximum range (4 $\div$ 20 mA for /I option) For single solenoid valves the reference input is 0 $\div$ +10 Vdc (4 $\div$ 20 mA for /I option)	Input - analog signal
E	-	INPUT -	For double solenoid valves the reference input is $\pm 10$ Vdc (4 $\div$ 20 mA for /I option) standard: differential input; /Z option: common mode INPUT+ referred to AGND	
C	5	AGND	Ground - signal zero for MONITOR signal signal zero for INPUT+ signal (only for /Z option)	Gnd - analog signal
F	6	MONITOR	Monitor analog output: $\pm 10$ Vdc maximum range; (4 $\div$ 20 mA for /I option)	Output - analog signal
-	7	NC	do not connect (pressure/force input for /SP, /SF and /SL options, see 9.3)	
-	8	NC	do not connect (pressure/force monitor for /SP, /SF and /SL options, see 9.3)	
-	9	VL+	Power supply 24 Vdc for driver logic	Input - power supply
-	10	VL0	Power supply 0 Vdc for driver logic	Gnd - power supply
-	11	FAULT	Fault (0V) or normal working (24V)	Output - on/off signal
G	PE	EARTH	Internally connected to the driver housing	

**Note:** A minimum time of 300 to 500 ms have to be considered between the driver energizing with the 24 Vdc power supply and when the valve is ready to operate. During this time the current to the valve coils is switched to zero.

### 10.2 ELECTRONIC CONNECTIONS - 5 PIN COMMUNICATION CONNECTORS

PIN	-PS Serial		-BC CANopen		-BP PROFIBUS DP	
	SIGNAL	TECHNICAL SPECIFICATION	SIGNAL	TECHNICAL SPECIFICATION	SIGNAL	TECHNICAL SPECIFICATION
1	NC	do not connect	CAN_SHLD	Shield	+5V	for termination
2	NC	do not connect	NC	do not connect	LINE-A	Bus line (high)
3	RS_GND	Signal zero data line	CAN_GND	Signal zero data line	DGND	data line and termination Signal zero
4	RS_RX	Valves receiving data line	CAN_H	Bus line (high)	LINE-B	Bus line (low)
5	RS_TX	Valves transmitting data line	CAN_L	Bus line (low)	SHIELD	

## 11 SOFTWARE TOOLS

The driver configuration and parameters can be easily set with the Atos E-SW programming software, available in three different versions according to the driver's communication execution: E-SW-PS (Serial), E-SW-BC (CANopen) and E-SW-BP (PROFIBUS DP).

For a more detailed description of software interface, PC requirements, adapters, cables and terminators, please refer to technical table G500.

**Programming software, must be ordered separately:**

**E-SW-\*** (mandatory - first supply) = Dvd including E-SW-\* software installer and operator manuals; it allows the registration to Atos digital service

**E-SW-\*-N** (optional - next supplies) = as above but not allowing the registration to Atos digital service

On first supply of the E-SW-\* software, it is required to apply for the registration in the Atos download area: [www.download.atos.com](http://www.download.atos.com).

Once the registration is completed, the password will be sent by email.

The software remains active for 10 days from the installation date and then it stops until the user inputs his password.

With the password you can also download, in your personal area, the latest releases of the Atos software, manuals, drivers and configuration files.

## 12 MAIN CHARACTERISTICS OF PROPORTIONAL DIRECTIONAL VALVES

Assembly position	Any position
Subplate surface finishing	Roughness index Ra 0,4 - flatness ratio 0,01/100 (ISO 1101)
Ambient temperature	-20°C $\div$ +70°C for -T execution; -20°C $\div$ +60°C for -TE and -TES executions
Fluid	Hydraulic oil as per DIN 51524 ... 535 for other fluids see section I
Recommended viscosity	15 $\div$ 100 mm <sup>2</sup> /s at 40°C (ISO VG 15 $\div$ 100)
Fluid contamination class	ISO 4406 class 20/18/15 NAS 1638 class 9, in line filters of 10 $\mu$ m ( $\beta_{10} \geq 75$ recommended)
Fluid temperature	-20°C +60°C (standard seals) -20°C +80°C (/PE seals)
Coil resistance R at 20°C	3 $\div$ 3,3 $\Omega$
Max. solenoid current	2,6 A
Max. power	35 Watt
Insulation class	H (180°) Due to the occurring surface temperatures of the solenoid coils, the European standards ISO 13732-1 and EN982 must be taken into account
Protection degree (CEI EN-60529)	IP65 for -T execution; IP67 for -TE and -TES executions
Duty factor	Continuous rating (ED=100%)

**13 DIAGRAMS** (based on mineral oil ISO VG 46 at 50 °C)

**13.1 Regulation diagrams**

DPZO-1:

- 1 = 1L5, 1DL5, 3L5, 3DL5
- 2 = 1S5, 1D5, 3S5, 3D5

DPZO-2:

- 3 = 1L5, 1DL5, 3L5, 3DL5
- 4 = 1S5, 1D5, 3S5, 3D5
- 5 = 1L3, 3L3
- 6 = 1S3, 1D3, 3S3, 3D3

DPZO-3:

- 7 = 1L5, 1DL5, 3L5, 3DL5
- 8 = 1S5, 1D5, 3S5, 3D5

DPZO-4:

- 9 = 1L5, 1DL5, 3L5, 3DL5
- 10 = 1S5, 1D5, 3S5, 3D5

DPZO-6:

- 11 = 1L5, 3L5
- 12 = 1S5, 1D5, 3S5, 3D5

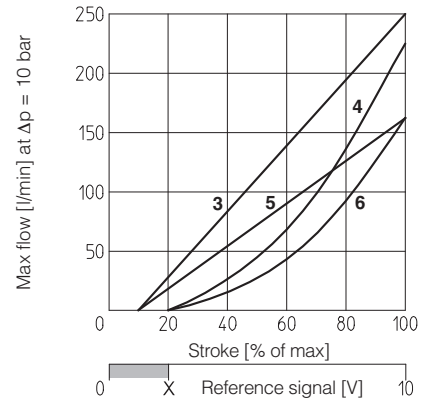
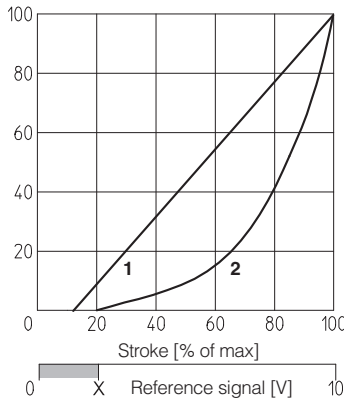

X = Threshold for bias activation depending to the valve type and amplifier type

**Notes:**

Hydraulic configuration vs. reference signal for double solenoid valves (standard and option /B):

Reference signal  $0 \div +10 \text{ V}$  } P → A / B → T  
 $12 \div 20 \text{ mA}$  }

Reference signal  $0 \div -10 \text{ V}$  } P → B / A → T  
 $4 \div 12 \text{ mA}$  }

Hydraulic configuration vs. reference signal for single solenoid valves:

Reference signal  $0 \div +10 \text{ V}$  } P → A / B → T (standard)  
 $12 \div 20 \text{ mA}$  } P → B / A → T (option /B)

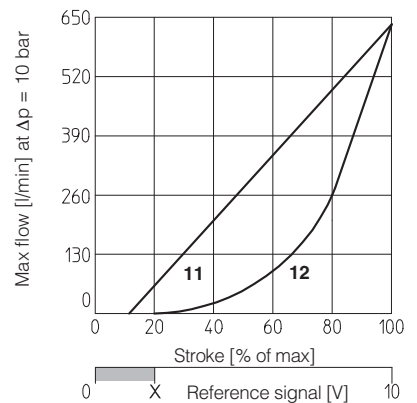
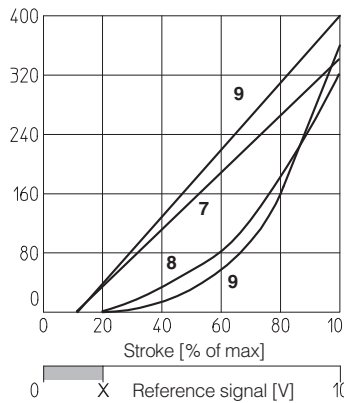

X = Threshold for bias activation depending to the valve type and amplifier type

**13** = differential - regenerative spool D9

D9 spool type with a fourth position specific to regenerative circuit, performed by means of an additional external check valve.

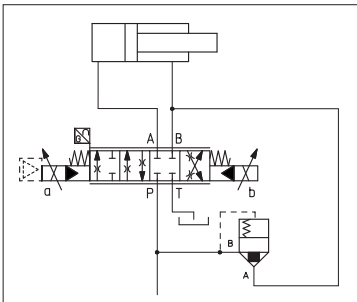

Application example

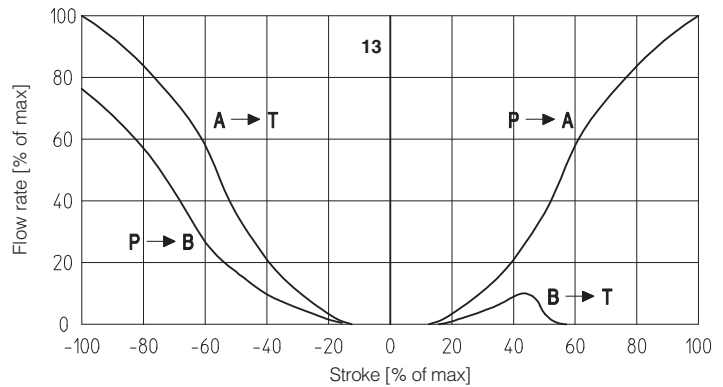

**14** = linear - internal regenerative spool L9

L9 spool type with a fourth position specific to regenerative circuit internal to the valve.

- 1 = P - B
- 2 = A - T
- 3 = P - A
- 4 = B - T
- 5 = P - B (regenerative)

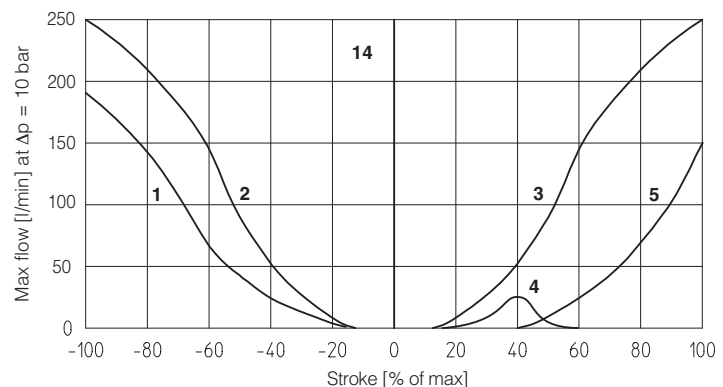

**15 = linear spool Q5**

Q5 spool type is specific for alternate P/Q controls and it can be used in combination with /S\* option of digital integral drivers, see tab. G212, or digital position controllers type Z-RI-TEZ (see tab. G330) or Z-ME-KZ (see tab. G340).

It allows to control the pressure in A port or B port and it provides a safety central position (A-T/B-T) to depressurize the actuator chambers.

The strong meter-in characteristic makes the spool suitable for both pressure control and motion regulations in several applications.

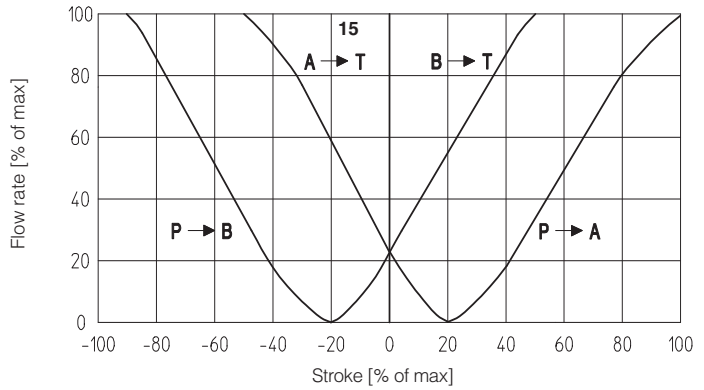

**16 = differential - progressive spool V9 (only for DPZO-2)**

V9 spool type is specific for alternate P/Q controls and it can be used in combination with /S\* option of digital integral drivers, see tab. G212, or digital position controllers type Z-RI-TEZ (see tab. G330) or Z-ME-KZ (see tab. G340).

This spool is specially designed to manage the whole injection cycle in plastic machinery, thanks to the following specific features:

- strong meter-in characteristic to allow the pressure control in A port during the holding pressure (P-A) and the plasticizing (A-T) phases
- safety central position (A-T/B-T) to depressurize the actuator chambers
- large A-T and B-T flow capability, required during the plasticizing phase, to discharge big volumes from high differential injection cylinders with low pressure drops and permitting the contemporary oil suction from tank.

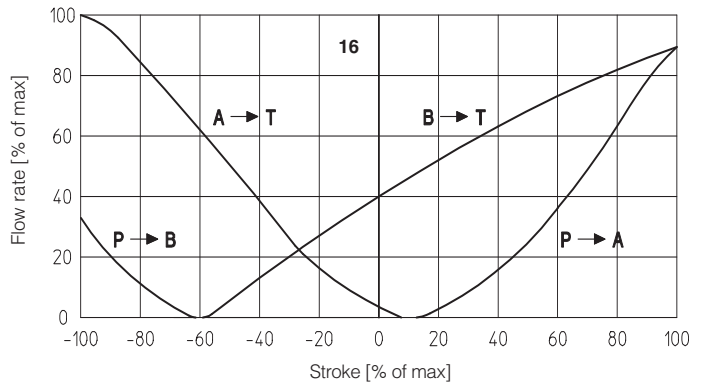

**13.2 Operating diagrams**

**Flow /Δp diagram**

stated at 100% of spool stroke

DPZO-1:

1 = spools L5, S5, D5, DL5, D9, V9

DPZO-2:

2 = spool L3, S3, D3

3 = spools L5, S5, D5, DL5, D9, L9, V9

DPZO-3:

4 = spools L5, S5, D5, DL5, D9, V9

DPZO-4:

5 = spools L5, S5, D5, DL5, D9, V9

DPZO-6:

6 = spools L5, S5, D5

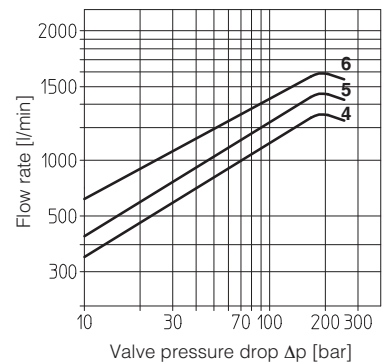
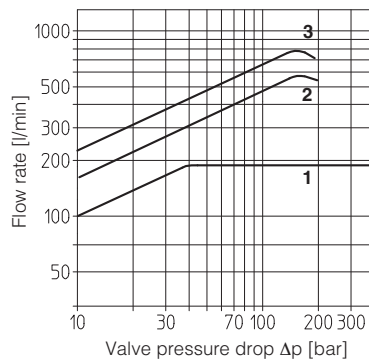

**13.3 Dynamic response**

The response times in section 3 have to be considered as average values.

For the valves with digital electronics the dynamics performances can be optimized by setting the internal software parameters.

**13.4 Operation as throttle valve**

Single solenoid valves (\*51) can be used as simple throttle valves:

Pmax = 250 bar

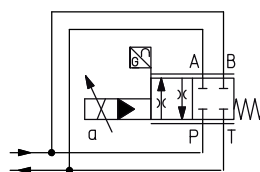

DPZO-*	151-L5	251-L5	351-L5	451-L5	651-L5
Max flow [l/min]	320	850	1300	1400	2000
Δp [bar]	30	30	30	30	30

**DPZO-T(\*)-1** (dotted line = double solenoid version)

**DPZO-T-1**

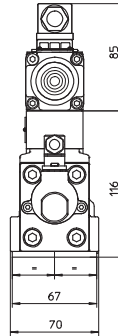
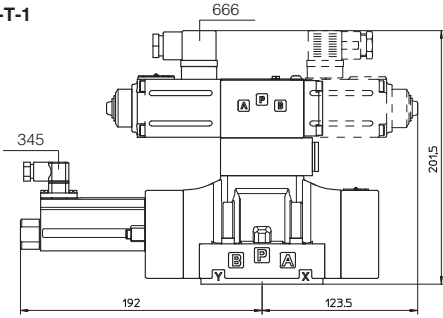

**ISO 4401: 2005**

**Mounting surface: 4401-05-05-0-05** (see table P005)

Fastening bolts:  
4 socket head screws M6x40 class 12.9  
Tightening torque = 15 Nm  
Seals: 5 OR 2050; 2 OR 108  
Diameter of ports A, B, P, T:  $\varnothing = 11$  mm;  
Diameter of ports X, Y:  $\varnothing = 5$  mm;

**Mass [kg]**

	T	TE, TES
DPZO-*-15*	8,5	8,9
DPZO-*-17*	9,4	9,8

**DPZO-TE-1**

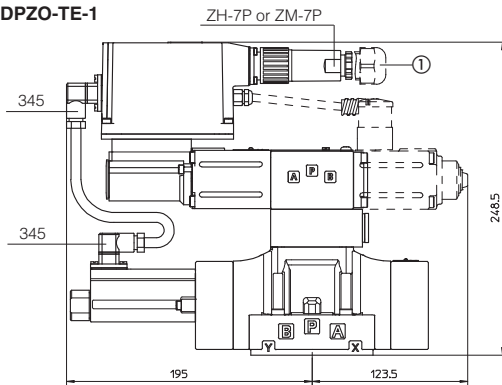

**DPZO-TES\*-1**

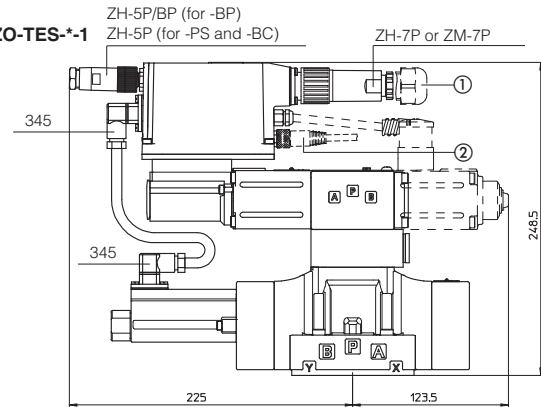

**DPZO-T(\*)-2** (dotted line = double solenoid version)

**DPZO-T-2**

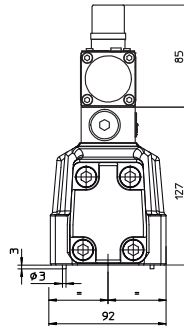
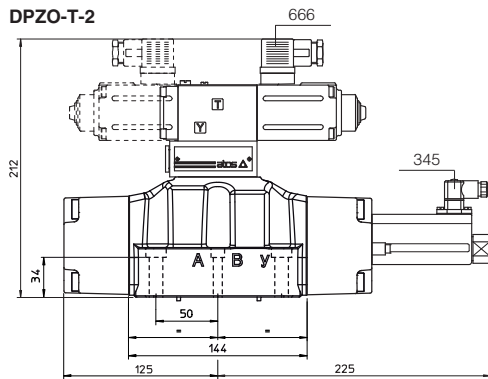

**ISO 4401: 2005**

**Mounting surface: 4401-07-07-0-05** (see table P005)

Fastening bolts:  
4 socket head screws M10x50 class 12.9  
Tightening torque = 70 Nm  
2 socket head screws M6x45 class 12.9  
Tightening torque = 15 Nm  
Seals: 4 OR 130; 3 OR 109/70  
Diameter of ports A, B, P, T:  $\varnothing = 20$  mm;  
Diameter of ports X, Y:  $\varnothing = 7$  mm;

**Mass [kg]**

	T	TE, TES
DPZO-*-25*	13,5	13,9
DPZO-*-27*	14,4	14,8

**DPZO-TE-2**

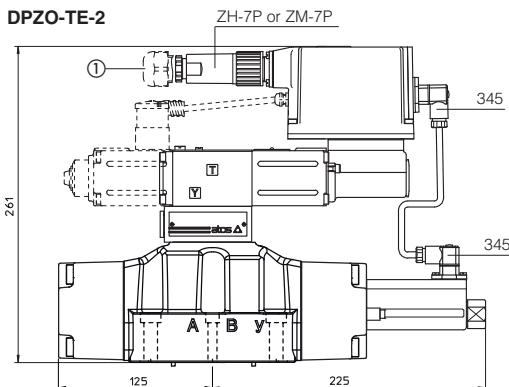

**DPZO-TES\*-2**

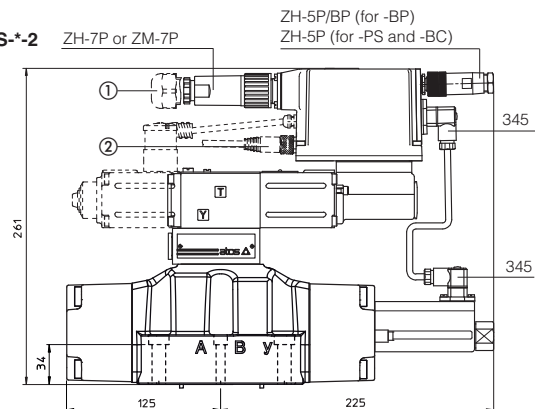

- ① Dotted line = 12 pin connector ZH-12P for options /SF, /SL, /SP, /Z
- ② = M8 connector ZH-4P-M8/5 moulded on cable 5 mt length for pressure or force transducer (options /SL, /SP)  
M8 connector ZH-4P-M8/2-2 moulded with 2 cables, 2 mt length for 2 pressure transducers (options /SF)

**NOTE:**

For option /B the proportional solenoid, the position transducer and the electronics (in case of execution -TE and -TES) are at side of port A of the main stage.

**DPZO-T(\*)-3** (dotted line = double solenoid version)

**DPZO-T-3**

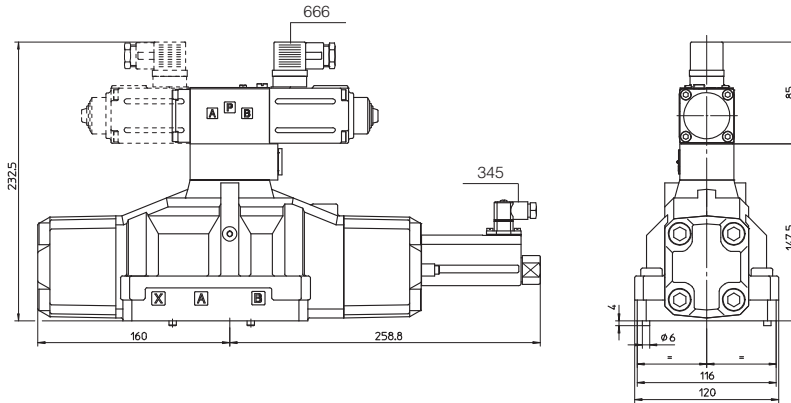

**DPZO-TE-3**

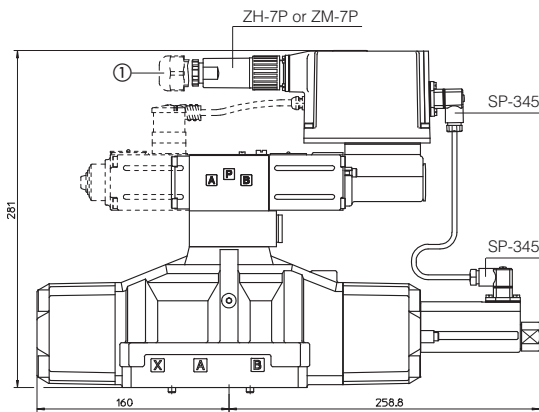

**ISO 4401: 2005**

**Mounting surface: 4401-08-08-0-05** (see table P005)

Fastening bolts:

6 socket head screws M12x50 class 12.9

Tightening torque = 125 Nm

Seals: 4 OR 4112; 3 OR 3056

Diameter of ports A, B, P, T:  $\varnothing = 24$  mm;

Diameter of ports X, Y, L:  $\varnothing = 7$  mm;

**DPZO-TES\*-3**

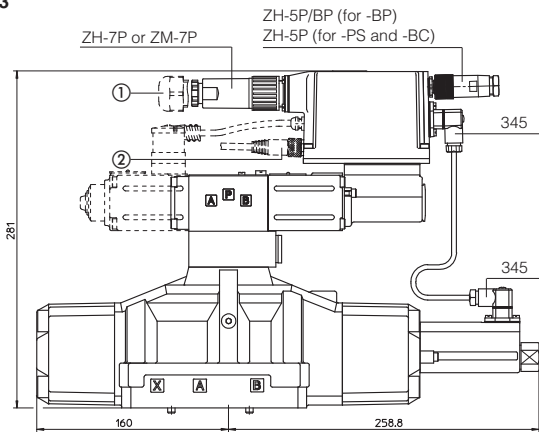

**Mass [kg]**

	T	TE, TES
DPZO-*-35*	17,1	17,5
DPZO-*-37*	18	18,4

① Dotted line = 12 pin connector ZH-12P for options /SF, /SL, /SP, /Z

② = M8 connector ZH-4P-M8/5 moulded on cable 5 mt length for pressure or force transducer (options /SL, /SP)  
M8 connector ZH-4P-M8/2-2 moulded with 2 cables, 2 mt length for 2 pressure transducers (options /SF)

**NOTE:**

For option /B the proportional solenoid, the position transducer and the electronics (in case of execution -TE and -TES) are at side of port A of the main stage.



**DPZO-T(\*)-4** (dotted line = double solenoid version)

**DPZO-T-4**

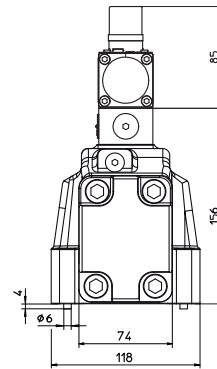
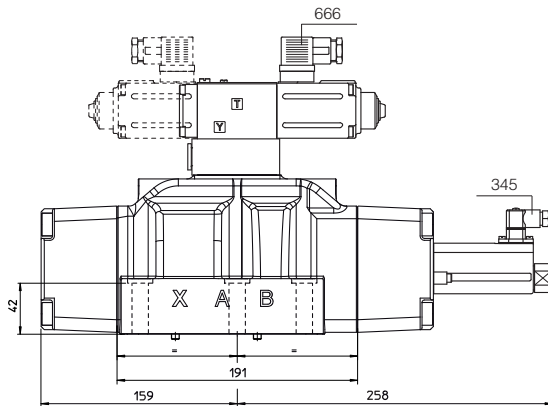

**DPZO-TE-4**

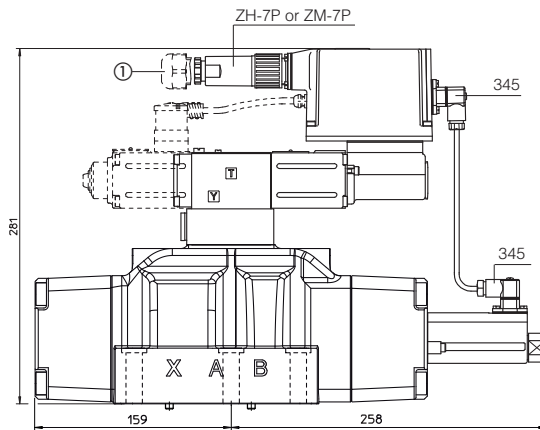

**ISO 4401: 2005**

**Mounting surface: 4401-08-08-0-05** (see table P005)

Fastening bolts:

6 socket head screws M12x60 class 12.9

Tightening torque = 125 Nm

Seals: 4 OR 4112; 2 OR 3056

Diameter of ports A, B, P, T:  $\varnothing = 24$  mm;

Diameter of ports X, Y:  $\varnothing = 7$  mm;

**DPZO-TES\*-4**

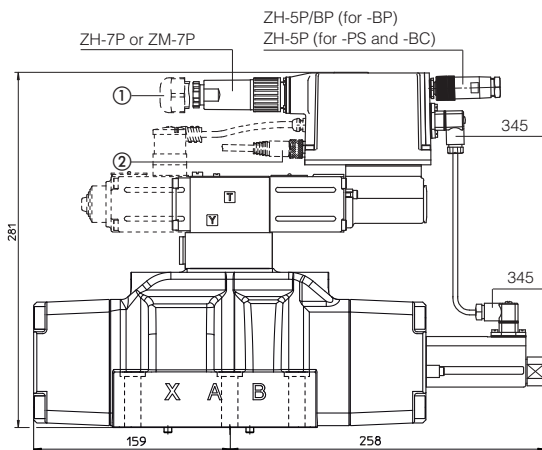

**Mass [kg]**

	T	TE, TES
DPZO*-45*	17,6	18
DPZO*-47*	18,5	18,9

① Dotted line = 12 pin connector ZH-12P for options /SF, /SL, /SP, /Z

② = M8 connector ZH-4P-M8/5 moulded on cable 5 mt lenght for pressure or force transducer (options /SL, /SP)  
M8 connector ZH-4P-M8/2-2 moulded with 2 cables, 2 mt lenght for 2 pressure transducers (options /SF)

**NOTE:**

For option /B the proportional solenoid, the position transducer and the electronics (in case of execution -TE and -TES) are at side of port A of the main stage.

**DPZO-T(\*)-6** (dotted line = double solenoid version)

**DPZO-T-6**

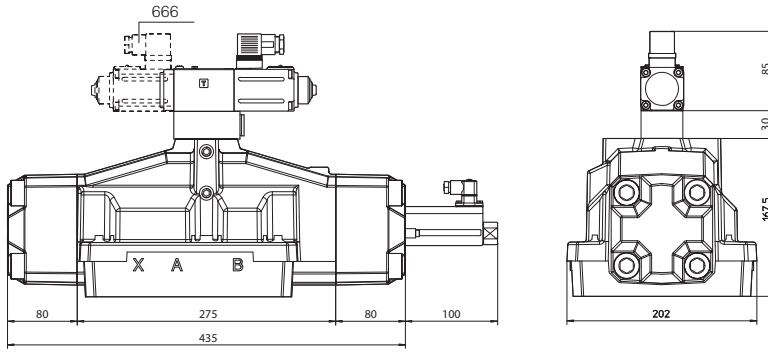

**DPZO-TE-6**

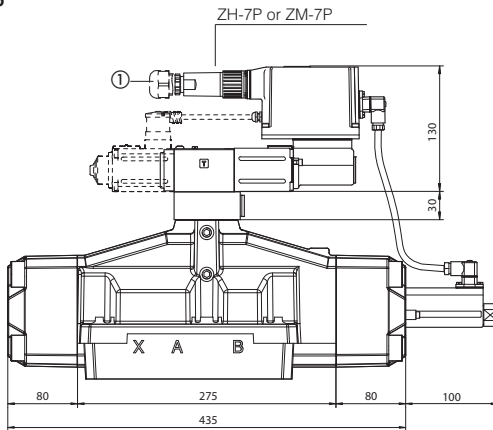

**ISO 4401: 2005**

**Mounting surface: 4401-10-09-0-05**

Fastening bolts:

6 socket head screws M20x90 class 12.9

Tightening torque = 600 Nm

Diameter of ports A, B, P, T: Ø = 34 mm;

Diameter of ports X, Y: Ø = 7 mm;

Seals: 4 OR 144, 3 OR 3056

**DPZO-TE-6**

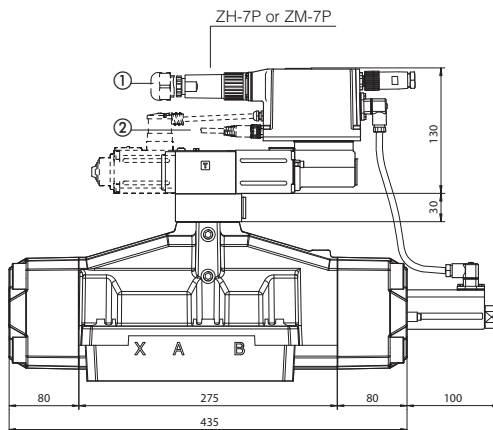

**Mass [kg]**

	T	TE, TES
DPZO-*-65*	41,7	42,3
DPZO-*-67*	42,5	43,1

**-TES EXECUTION**

① Dotted line = 12 pin connector ZH-12P for options /SF, /SL, /SP, /Z

② = M8 connector ZH-4P-M8/5 moulded on cable 5 mt lenght for pressure or force transducer (options /SL, /SP)  
M8 connector ZH-4P-M8/2-2 moulded with 2 cables, 2 mt lenght for 2 pressure transducers (options /SF)

**NOTE:**

For option /B the proportional solenoid, the position transducer and the electronics (in case of execution -TE and -TES) are at side of port A of the main stage.

18 **MODEL CODES OF POWER SUPPLY AND COMMUNICATION CONNECTORS (to be ordered separately)**

VALVE VERSION	-T		-TE, -TES		-TE/Z	serial (-PS)	PROFIBUS DP (-BP)	TES /SF, /SL, /SP
	Power supply	Transducer			-TES /Z, /SF, /SL, /SP	or CANopen (-BC)		(transducer)
CONNECTOR CODE	666	345	ZH-7P	ZM-7P	ZH-12P	ZH-5P	ZH-5P/BP	ZH-4P-M8/* (1)
PROTECTION DEGREE	IP65	IP65	IP67	IP67	IP67	IP67	IP67	IP67
DATA SHEET	K500		G200, G210, K500			G210, K500		G212, K500

(1) M8 connector ZH-4P-M8/5 moulded on cable 5 mt lenght for pressure or force transducer (options /SL, /SP)

M8 connector ZH-4P-M8/2-2 moulded with 2 cables, 2 mt lenght for 2 pressure transducers (options /SF)

connectors supplied with the valve