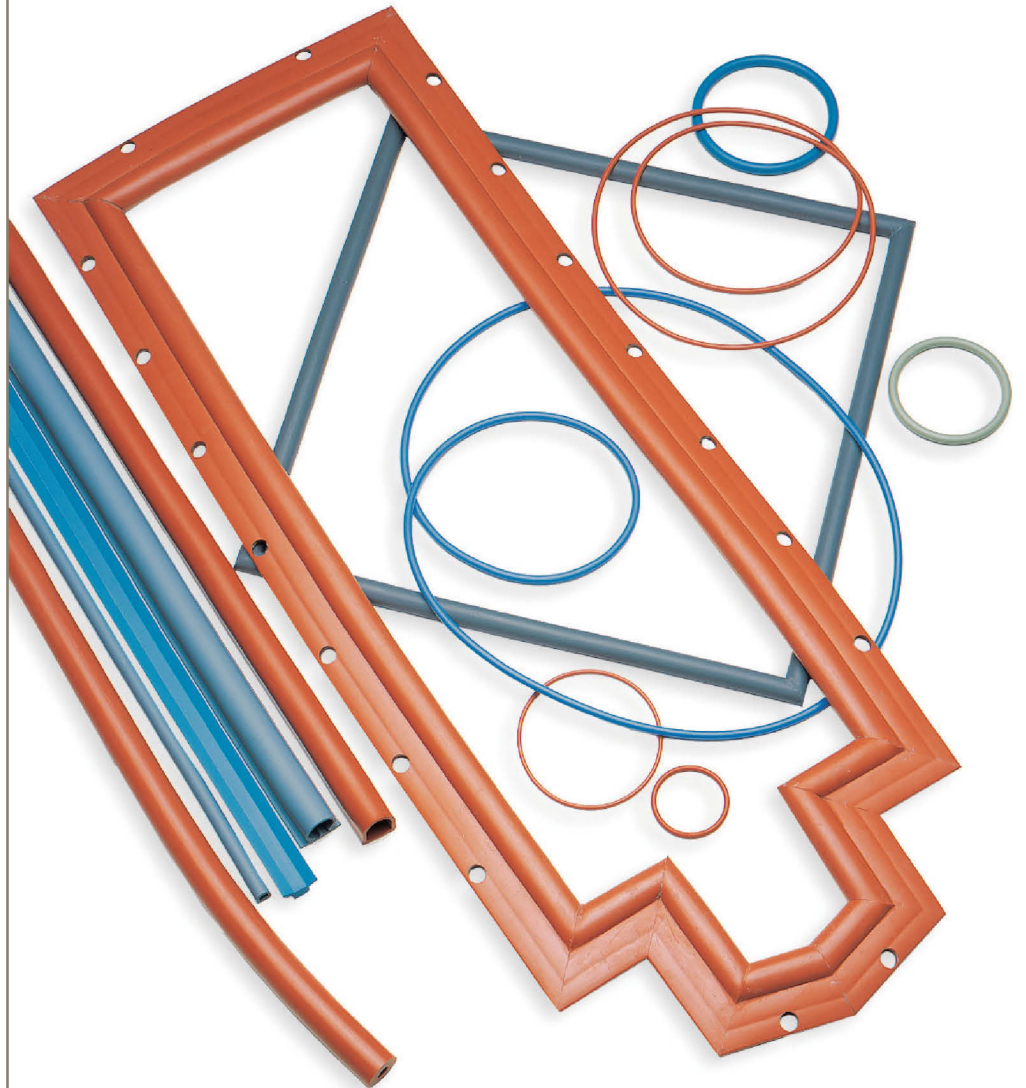


aerospace  
climate control  
electromechanical  
filtration  
fluid & gas handling  
hydraulics  
pneumatics  
process control  
sealing & shielding



Photo Courtesy of U.S. Army



# ParFab™ Design Guide

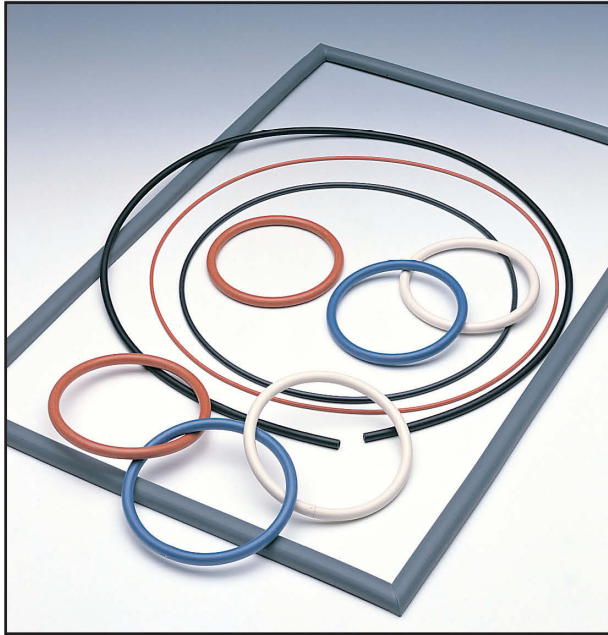
Extruded and Hot Vulcanized Gaskets

TSD 5420



ENGINEERING YOUR SUCCESS.

# ParFab Design Guide



## Table of Contents

Introduction	1
ParFab Basic Facts	2
ParFab Design Guide	4
ParFab Elastomers	8
Media Compatibility Table	9
UL Listed Materials	10
Standard ParFab Materials	11
Tolerance Guide	12
Standard Profiles and Part Numbers	13
Custom Profile Guide	20
Compression/Deflection	25
Compression/Deflection Tables	27
Elastomer Technology	32
Parker Offer of Sale	40
Other TechSeal Products and Services	IBC



### **Failure, improper selection or improper use of the products and/or systems described herein or related items can cause death, personal injury or property damage.**

This document and other information from Parker Hannifin Corporation, its subsidiaries and authorized distributors provides product and/or system options for further investigation by users having technical expertise. It is important that you analyze all aspects of your application and review the information concerning the product or system in the current product catalog. Due to the variety of operating conditions and applications for these products or systems, the user, through his or her own analysis and testing, is solely responsible for making the final selection of the products and systems and assuring that all performance, safety and warning requirements of the application are met.

The products described herein, including without limitation, product features, specifications, designs, availability and pricing, are subject to change by Parker Hannifin Corporation and its subsidiaries at any time without notice.

#### **OFFER OF SALE**

The items described in this document are hereby offered for sale by Parker Hannifin Corporation, its subsidiaries and its authorized distributors. This offer and its acceptance are governed by the provisions stated on page 40 of this document entitled "Offer of Sale"

ParFab is a Trademark of the Parker Hannifin Corporation.



# TechSeal Division ParFab™ Design Guide

The Parker TechSeal Division JBL Operations produces a wide range of “standard” and “custom” extruded products fabricated from a variety of “Sealing Grade” material formulations. This brochure contains a listing of standard extruded profiles used to fabricate spliced rings, gaskets or long length bulk footage on a spool or coiled for customer fabrication.

**Extruded and Spliced/Fabricated Products** are made utilizing a hot vulcanization process to provide spliced rings and custom gaskets from either “standard” or “custom” cross-sectional profiles. TechSeal’s precision extruded and spliced products offer an ideal, cost-effective sealing solution for many applications. These include low-closure force seals, large diameter profiles that cannot be molded, or requirements for hollow O-rings, non-standard solid O-rings, and other extruded profiles with an inside diameter larger than 1.500” (38.1mm). All TechSeal extruded and spliced parts are “Hot Vulcanized,” provide the designer with a tremendous amount of flexibility and can be attached/assembled into grooves or on to flat surfaces.



**Long Length Extrusions** are typically supplied on cardboard or plastic spools, or free-coiled in lengths of up to 5000 feet depending upon cross-section.



## Extruded Profile Availability

TechSeal offers many standard extruded profiles in Solid & Hollow-O, Solid & Hollow-D, U-Channel, Rectangular, Solid & Hollow Square, and Hollow-Dart configurations. These profiles are typically used for fabrication into spliced rings or custom gaskets; they also can be supplied in bulk cord. See pages 13 through 19 for a complete listing of standard profiles and groove recommendations.



## Material Availability

Please refer to page 11 for TechSeal’s standard material offering of our most commonly used compounds. Please contact the TechSeal Division if you have a requirement for a material other than those listed. TechSeal offers a broad range of materials for many different markets. Many TechSeal compounds meet or exceed specialty grade standards set by the UL, ASTM, Military, FDA, USP Class VI, NSF and other agencies.

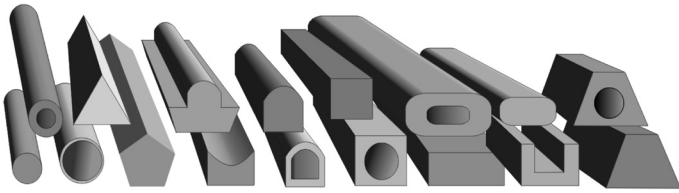
## TechSeal ParFab - Product Types

ParFab products contained in this brochure or any custom extruded profile can be supplied as:

- **Spliced Rings (Hollow and Solid)**
- **4-corner PSA-backed spliced “Picture Frame” gaskets**
- **Custom fabricated gaskets**
- **Cut-to-length product**
- **Bulk cord with or without PSA - coiled or spooled**

Please contact the TechSeal Division’s Sales and Marketing Department for part number assignment for all non-standard cross-sections for spliced or fabricated parts.

**Spliced Rings** All TechSeal Spliced Rings are “Hot Vulcanized” and can be provided in any of TechSeal’s standard or customer specified cross-sectional configurations. Minimum spliced diameter is 1.500” (38.1mm) inside diameter, however this is cross-sectional dependent.



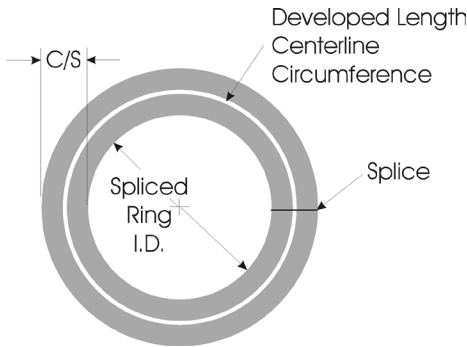
To order TechSeal Spliced Rings, simply choose the cross-section and inform TechSeal of your preference for either the spliced I.D. or developed length. To specify a spliced ring tolerance you can either choose the I.D. or the developed length prior to splicing/vulcanization. Please see Table 1 below for guidelines.

**Developed Length Specifications/Guidelines**

Developed Length (In.)	Tolerance
5" (127.0mm) to 36.99" (937.7mm)	± 0.062" (1.58mm)
37" (939.8mm) to 100" (2540mm)	± 0.125" (3.18mm)
over 100" (2540mm)	± 0.5% of D.L.

**Table 1 - Developed Length Tolerances**

**Converting between developed length and spliced O-ring size:**



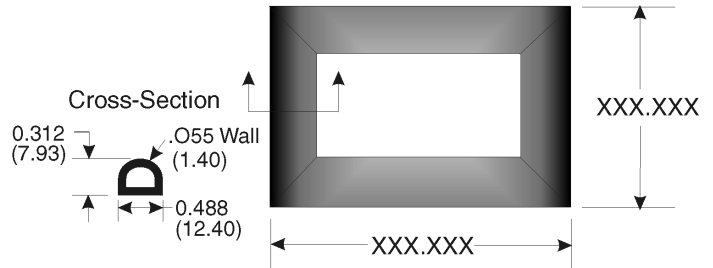
**Figure 1 - Developed Length**

**Example:**

A spliced ring with an I.D. of 10 in (254mm) and a cross sectional thickness 0.250 ± 0.005 in (6.35 ± 0.13mm) is required for a sealing application. What is the equivalent developed length and what tolerances can be expected?

- Developed Length = (I.D. + Cross Section) x 3.1416
- Tolerance (I.D.) = Developed Length Tolerance / 3.1416 + Cross Sectional Tolerance
- Developed Length = (10 + 0.250) x 3.1416 = 32.201 in. or (254 + 6.35) x 3.1416 = 817.92mm
- Therefore: Developed Length Tolerance = ± 0.062 in. (1.58mm) per the above table
- Tolerance (I.D.) = 0.062 / 3.1416 + 0.005 = ± 0.025 in. or 1.58/3.1416 + 0.13 = ± 0.633mm

**Four-Corner Spliced Picture Frame Gaskets** are a good solution for flat panel “no groove sealing” when PSA is added to backing and are typically used for environmental sealing applications. To specify a Four-Corner Picture Frame Gasket, simply give us the outside dimensions or prepare a drawing with the selected cross-section and the outside gasket dimension (see Fig. 2). Please contact the factory for manufacturability if selected cross-section is less than .100” (2.54mm). See Table 2 for outside gasket length tolerances.



**Figure 2 - Typical TechSeal Picture Frame Gasket**

Dimension	Tolerance
Up to 30" (762 mm)	±0 .062 (+/- 1.57 mm)
Over 30" (762 mm)	± 0.4% of the dimension

**Table 2 - Four-Corner Spliced Gasket Standard Tolerances**

**Custom Fabricated Gaskets** – TechSeal can supply virtually an unlimited combination of custom fabricated gaskets. Please contact TechSeal's Application Engineers for assistance with design and part number input. Customer drawings are required for non-standard parts.

**Bulk Cord** – Standard and custom designed extrusions can all be supplied in bulk cord either coiled or spooled. We utilize the best commercial practices with either cardboard spools, plastic spools, or free-coil packaging. Contact the TechSeal Division for more information regarding standard sizes or special packaging requests.

**Cut To Length Product** - TechSeal extruded products can be supplied as cut to length products from 0.020” (0.51mm) to over 1,000 ft. (305m) long. Contact the TechSeal Division for more specific information in reference to your exact requirements. Tolerances are cross-sectional and material dependent.

**Pressure Sensitive Adhesive (PSA) Backed Extrusions-**

PSA Backing can be applied to most extruded profiles with a flat surface such as Hollow and Solid D's, Hollow and Solid Squares, Rectangles or U-Channel extruded profiles. Minimum extruded cross-sectional width for PSA to be applied on is 0.125” (3.18mm).

**Pressure Sensitive Adhesives (PSA)**

TechSeal offers two types of PSA; Standard (ST) and High Temp (HT). Product utilizing the ST Type PSA is our standard and will be lower cost.

Pressure-Sensitive Adhesive Widths Available	
Inch (mm):	
.090 (2.29)	.200 (5.08)
.100 (2.54)	.250 (6.35)
.125 (3.17)	.375 (9.52)
.160 (4.06)	.625 (15.87)

**Table 3 - Standard PSA Widths Available**

TechSeal's extruded elastomers are available with a very tenacious acrylic pressure sensitive adhesive (PSA) for permanent attachment. Typical properties for the standard temperature (ST) and high temperature (HT) adhesive are shown below. Peel strength data for ST adhesive is shown in Table 4.

Property	Aluminum	Steel
Initial Peel Strength	6.0 PPI	6.0 PPI
Heat Aged Peel Strength *	5.4 PPI	5.4 PPI
Humidity Aged Peel Strength **	6.0 PPI	6.0 PPI

Peel Strength Test Data per ASTM D1000 (90° peel)  
 \*Heat aging 168 hrs / 158°F (70°C)  
 \*\* Humidity Aging 168 hrs / 95% RH / 158°F (70°C)

**Table 4 - Typical Peel Strength**

**Pressure Sensitive Adhesives - Typical Properties Standard Temperature PSA:**

**PSA Description:** Double-coated acrylic tape

**Release Liner:** 84 lb. siliconized polycoated kraft paper

**Service Temperature Range:** -40° to 150°F (-40° to 66°C).  
 PSA will function for short periods of time, for example 200 hours @ 200°F (94°C). Ultimate high temperature limit 250°F (121°C).

**Shelf Life Conditions:** One year at 70°F (21°C) / 50% RH

**Application Temperature Range:** 40° to 150°F (4° to 66°C)

**High Temperature PSA:**

**PSA Description:** High Performance Silicone

**Release Liner:** 84 lb siliconized polycoated kraft paper

**Service Temperature Range:** -130° to 500°F ( -90° to 260°C)

**Shelf Life Conditions:** Six months @ at 70°F (21°C)/50% RH

**Application Temperature Range:** 40° to 150°F (4° to 66°C)

**Surface Preparation of Metallic Substrates Prior to the Application of Pressure Sensitive Adhesive (PSA)**

It is very important to follow the following instructions to ensure maximum adhesion of the PSA to the metal substrates. Failure to comply with the cleaning process could result in poor adhesion. Proper safety precautions should also be followed to protect the operator.

**Materials Required:** 3M Scotch Brite Pads or equivalent, Rubber Gloves, Safety Glasses, Lint Free Cotton Wipes, MEK or Acetone or Isopropyl Alcohol (IPA)

**Surface Preparation of Conversion-Coated Aluminum and Phosphate-Coated Steel and plastic.**

- Using a clean, lint-free applicator, moistened with MEK, acetone solvent or IPA, wash the aluminum surface until all traces of contamination have been removed.
- Clean the surface until the cotton applicator shows no discoloration.
- If discoloration still exists, continue washing, changing the cotton applicator each time, until clean. *Note: With phosphate coatings, it is very hard to remove all discoloration from the surface so it is up to the operator to determine the cleanliness of the surface prior to bonding. Typically, cleaning the surface 3 times is required.*
- Allow the substrate to dry completely at room temperature. After the cleaning sequence is complete, do not touch the substrate with bare hands prior to gasket installation.
- If the clean surfaces do not have the PSA applied within an 8-hour period, rewash using the above process.

**Surface Preparation of Stainless Steel and Mild Steel**

- Using a Scotch Brite 3M pad or equivalent, lightly abrade the steel surface.
- Blow the dust residue off the steel surface with oil free filtered air.
- Follow Steps A through E from previous section to complete surface preparation.

**Gasket Installation Procedure**

- Cut gasket material to specific lengths per drawing. If gasket is one piece (e.g., four corner spliced gasket), pre-fit the assembly to ensure fit and location.
- Remove a portion of the release liner and position the gasket. Press firmly against gasket to tack in place. Continue pressing along entire length of gasket until it is positioned and aligned to the mating surface.
- Using thumb pressure or a rubber roller for ultimate adhesion, apply moderate pressure to the entire gasket to ensure complete contact between the PSA and the substrate surface.

### Optimum Application Temperatures

Temperatures below 50°F (10°C) can cause poor gasket adhesion to substrate surface during assembly. Ideal gasket installation temperature is 72°F (22°C), or room temperature. All materials should be stored at this temperature when not in use. If hardware gasket materials are stored below 50°F (10°C) these parts should be brought to a warmer environment and allowed to come to room temperature before proceeding with the installation of the gasket assembly.

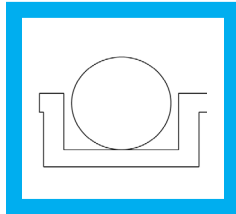
**Note:** It is important during this rolling procedure that the operator not apply excessive pressure to the gasket. Extreme positive pressure will cause the gasket to elongate and creep as it relaxes, which may result in a weak or intermittent bond to the substrate surface and have an effect on the seal fit.

### Seal Attachment Options

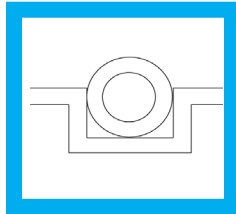
TechSeal Extruded Profiles can be attached to customer's hardware with several attachment options. The more common forms are:

#### Standard O-Ring Type Groove:

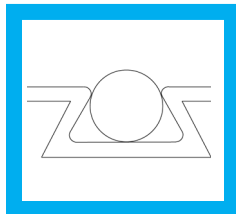
Good method for capturing o-rings and other special cross-sectional shapes. Groove walls provide compression stop, when seal is properly designed metal-to-metal contact is possible.



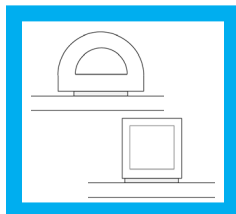
**Groove for Friction-Fit Seal:** Only possible with Hollow-O cross-sections or special custom designed profiles. Not possible with Solid-O's due to gland overfill concerns. Groove walls provide compression stop. TechSeal Friction-Fit Seal Designs aide in assembly without using adhesive.



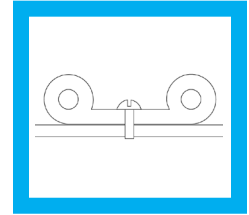
**Dovetail Groove:** Commonly used groove type for molded or spliced o-rings in vacuum sealing. Dovetail groove holds the seal in place in such a way where it cannot fall out while allowing area in the corners for the seal to move under compression. These grooves are very expensive to machine, and the tolerances are especially critical. Therefore, it should be used only when it is necessary.



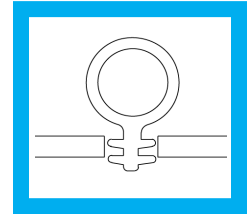
**PSA Backed Extrusions:** Provides "No-Groove" Sealing. Good solution for low pressure sealing of enclosures where machined or cast grooves are not practical due to thin covers. Typically utilized as outdoor environmental seals capable of passing wind driven rain tests.



**Hardware Captured:** This attachment method typically does not require adhesive to hold the seal in place nor a groove, while assuring capture of the seal by utilizing hardware.



**Press Fit into Notch:** When properly designed, the "notch" method can eliminate the need for adhesive, additional hardware and groove. Primarily utilized as door



### Basic ParFab Design Guide

#### Selection of the Seal Cross-Section

Selection of the optimum seal cross-section is a blend of the application environment, the gland geometry available, and knowledge of similar designs and concepts that have been successfully utilized in the past.

Many different profile shapes and sizes are available in standard configurations, and with the design assistance available from TechSeal, unique profiles can be developed for specific applications.

Establishing the optimal seal profile is just as important as establishing the ideal material for a given application. In fact, the combination of these two factors must be considered when designing or selecting the best seal for an application.

There are several major categories that must be taken into consideration when establishing the best seal candidate for a given application:

1. Cross-section squeeze or compression
2. Compressive force
3. Installation stretch
4. Gland fill (also termed the "volume-to-void" ratio)
5. Seal material selection
6. Gland groove considerations
  - a) Flanged surfaces
  - b) Corner radius
  - c) Gland surface finish
7. Application specific functional requirements

The following information is intended to serve as a guide to assist in selecting the best profile candidate and establishing the gland needed to generate an effective seal for the application.

**Cross-Section Squeeze**

The amount of compression or squeeze that a seal is given is defined as the amount of actual deflection or displacement that occurs to the seal cross-section after force is applied, and is usually referred to as a percentage of the original value. Percent compression or squeeze is calculated based upon the following formula:

$$((\text{Seal C/S OD} - \text{Gland Depth}) / (\text{Seal C/S OD})) \times 100 = \% \text{ Squeeze}$$

**Recommended Deflection For Various TechSeal Extruded Elastomer Shapes**

Cross-Section Geometry	Minimum Deflection	Nominal Deflection	Maximum Deflection
Solid "O"	10%	20%	30%
Solid "D"	10%	20%	30%
Rectangular	8%	15%	25%
Hollow "O", "D" and "P"	15%	30%	50%

*Note: For increased deflection requirements, TechSeal can provide special designed cross-sections/shapes.*

**Table 7 - Recommended Deflection**

For static sealing applications with solid profiles the general "rule of thumb" is to not exceed 30% compression based upon the combined effects of the minimum and maximum values of the seal cross-section OD, the dimensions of the gland, the tolerance stack-ups of the mating parts, and the range of gland fill.

Calculations for compression or squeeze must include allowances for tolerance stack-ups of both the seal cross-sectional outside dimension and the gland depth, using both the minimum and maximum values. If clearance gaps are destined to be part of the assembly, the dimensions associated with the gaps must be included in the calculations. The result is the establishment of a squeeze or compression range with calculated minimum and maximum values, using the formulas below:

**Minimum Cross-Section Squeeze Percent Formula**

$$\frac{(\text{Seal OD Min} - (\text{Gland Depth Max} + \text{Clearance Gap Max}))}{\text{Seal OD Min}} \times 100$$

**Maximum Cross-Section Squeeze Percent Formula**

$$\frac{(\text{Seal OD Max} - (\text{Gland Depth Min} + \text{Clearance Gap Min}))}{\text{Seal OD Max}} \times 100$$

**Compressive Force**

Compressive force or load deflection is defined as the force required to deflect a seal's cross section along each linear inch of the seal. Factors that can influence this characteristic include the physical properties of the seal material, the dimensions of the cross-section, the configuration of the seal cross-section (profile shape, hollow versus solid, etc.), the dimensions of the gland cross-section, seal physical containment, the amount of compression and the linear compression distance. Taking all these factors into consideration the anticipated load becomes a range of values, and is truly application specific. It is suggested that the proper material, squeeze and gland fill parameters be defined first, then adjusted as necessary to establish the best load deflection characteristics for the application.

Please refer to the compression/deflection graphs on pages 27 through 31 for specific force requirements based upon squeeze percentages, materials and profile configurations.

**Installation Stretch**

Installation stretch takes place when the inside diameter (ID) of the seal (or the internal perimeter (IP) of the spliced seal) is smaller than the inside diameter of the gland (or the internal perimeter of the gland). This required that the seal be stretched to fit into the groove of the assembly. Normally this is a desirable static sealing condition.

Installation stretch usually referred to in terms of a percentage, is similar to the squeeze calculations presented earlier, is that it must established using the tolerance stack-ups of both the seal ID (IP) and the Gland ID (IP). Please refer to the formulas that follow:

**Minimum Installation Stretch Percent Formula**

$$\frac{(\text{Gland ID Min} - \text{Seal ID Max})}{\text{Gland ID Min}} \times 100$$

**Maximum Installation Stretch Percent Formula**

$$\frac{(\text{Gland ID Max} - \text{Seal ID Min})}{\text{Gland ID Max}} \times 100$$

In many instances, it may be desirable to not have any seal stretch at all. This occurs in applications where there is no groove present, or when the hollow seal's cross-section has a wall (radial) thickness that may have a tendency to kink or buckle on the corners.

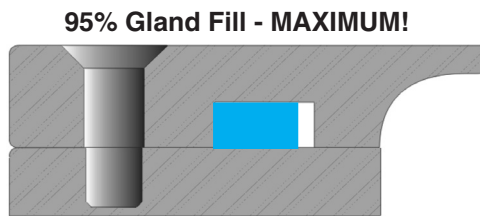
In order to reduce the risk of splice failure, it is recommended that an installation stretch of 30% maximum be imposed. With smaller diameter seals this may become difficult, depending upon the material properties and the dimensions of the cross-section. The force required to stretch the seal is part specific, meaning the combined effect of the material properties, seal cross-section, wall

thickness and splice surface contact area can have a synergistic effect on the required stretch force. Seal recovery time should be allowed into the process when high installation stretch percentages occur.

It is also suggested that an installed ID (IP) stretch percentage of 0.5% to 3% be used for all traditional gland configurations. Beyond 3% the life of the seal may be reduced, and excessive strain can occur at the spliced joint. Designing in a small amount of installation stretch can assist the assembly process, holding the seal in the proper position until the mating components are in place. This can also reduce the possibility of seal pinching due to the presence of excess material.

### Gland Fill (Volume-to-Void Ratio)

Gland fill is defined as the cross-sectional amount of material (volume) found in a gland cross-sectional area (void). This value is typically referred to in terms of a percentage.



**Figure 3 - Maximum Gland Fill Percentage**

For static applications a 95% maximum gland fill is recommended. It is extremely important that the gland fill percentage be established in terms of a range, using minimum and maximum values, which has taken into account the tolerance stack-ups of the assembly and the seal cross-sections together. If a clearance gap is present in the assembly, the associated dimensions must be included in the calculations, as they were when the cross-section squeeze dimensions were established.

### Minimum Gland Fill Percentage Formula

$$\frac{(\text{Minimum Seal C/S Area})}{(\text{Maximum Gland C/S Area})} \times 100$$

### Maximum Gland Fill Percentage Formula

$$\frac{(\text{Maximum Seal S/C Area})}{(\text{Minimum Gland C/S Area})} \times 100$$

### Seal Material Selection

Optimizing the balance of physical properties and the environment will allow the establishment of the best sealing solution for each application. Please refer to pages 8 through 10 for additional information on physical and chemical properties.

### Gland Groove Considerations

All elastomer materials are subject to compression set, or a loss in return force, over time. Over-compression (squeeze) can cause the polymer chains within the seal to fracture un-

desirably, reducing the long term sealing effectiveness.

Flange surfaces usually can not be held perfectly flat after the bolts are tightened during assembly. As a result, the seal may become over-compressed in the areas of the bolts. Proper groove design can prevent this from happening. Use of a groove allows for metal-to-metal or plastic-to-plastic contact of the mating parts of the assembly, preventing over-compression of the seal element. A single groove is usually all that is needed.

### Flange Surfaces

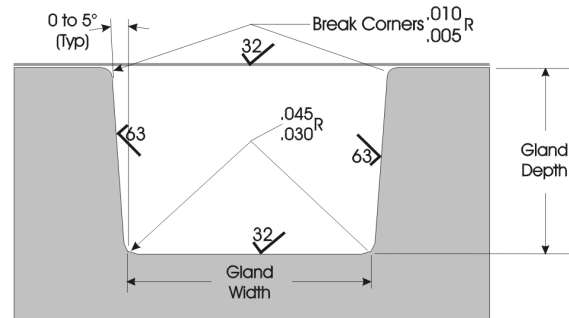
The most frequently used profiles are "O" or "D"-shaped profiles, with either solid or hollow cross-sections. Flange fasteners should be located in positions that create uniform pressure distribution at the corners, and minimal clearance gaps around the component periphery. For these profiles, a high bolt torque is usually not needed to seal perfectly.

### Corner Radius

In order for a spliced, solid round cross-section seal (o-ring) to seat properly in an application, the inner radius of the groove at the corners must be equal to or greater than the cross-sectional width of the seal. Other profiles, especially hollow ones, require a larger inside radius to prevent kinking or pinching. Typically a design allowance of  $2^{1/2}$  to 3 times the cross-section is used for the inside corner radius.

### Gland Surface Finish

The surface finish of the gland is a very important part of the sealing solution. The surface should be free of nicks, burrs, scratches or dents. As illustrated in the diagram below, a surface finish not to exceed 64 microinches on the gland sides and a 32 microfinish on the sealing compression surfaces is typically recommended.



**Figure 4 - Typical Gland Surface Finish**

### Solid Cross-Section Profiles

Various types of solid cross-section seal profiles can be used to generate effective static environmental sealing results in an application. Typical standard configurations include, but are not limited to solid O-, D-, U-, P-, rectangular or square profiles.

Solid round cross-section seals are typically termed O-Rings in the sealing industry. Use of a solid round cross-section is preferred in many applications because the seal can be deflected more easily under a given load versus a square or



rectangular cross-section seal. The sealing return force is focused on the centerline of the cross-section, thereby generating an effective seal over a relatively small area. Solid O-, D-, square and rectangular profiles can also be produced to fit almost any groove cross-section, which makes seal design easier, and allows for field retrofit.

### Hollow Cross-Section Profiles

Hollow seal profiles are typically used when sealing in applications that have one or more of the following characteristics:

1. **Clearance gaps are present after assembly.**
2. **The gland cross-section is more deep than narrow.**
3. **Radial interference (squeeze) is needed to assist the end product assembly process.**
4. **Low closure force is needed.**
5. **Seal cross-section surface contact area maximization without overflow.**

Hollow profiles, and fabricated environmental seals made from hollow profiles, allow the designer to select from a vast array of seal options with almost an infinite amount of dimensional combinations. Typical configurations include hollow O-, D-, P-, dart and square profiles. Product options, after establishing the proper cross-section, include coiling or spooling in long lengths, PSA (Pressure Sensitive Adhesive) along a flat surface, single splicing to create a continuous hollow ring, four corner splicing to create a "picture frame" configuration hollow seal, and venting of the spliced seal.

### Application Specific Functional Requirements

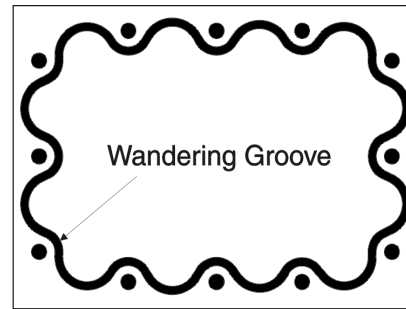
#### Friction Fit

Hollow profiles, primarily hollow o-rings, can be designed with a certain amount of radial interference into the gland. This is often desirable in applications where the seal may have a tendency to fall out prior to completion of the assembly process. The friction fit hollow o-ring is also applicable for typical o-ring glands having a draft angle as shown in figure 4. Please refer to page 15 in this handbook to reference the standard "friction fit" hollow o-ring sizes, or contact the TechSeal division for design assistance.

The cross-sections of friction fit seals have been compensated to prevent gland overflow in the application. Squeeze is generated from four planes.

#### Wandering Grooves

A wandering groove, by our definition, is a seal gland that is not perfectly square or does not have parallel sides when viewed from above. This typically occurs in applications that require the sealing element to go around bolts, bolt holes or fasteners. An example of this is shown in Figure 5.



**Figure 5 - Wandering Seal Groove**

TechSeal's extrusion and splicing capabilities provide multiple solutions for these types of applications for several reasons:

1. *The seals are not molded. In many instances special molded shapes seals are used in wandering groove applications. The molds are part or application specific - typically used to produce seals to solve one specific problem. If the part volume is high, multiple cavities and/or multiple molds may be required.*
2. *The optimum seal can be selected from TechSeal's standard profile offering, or custom designed in conjunction with our Application Engineering staff. We have almost an unlimited offering of profile and material combinations.*
3. *The profile can be either solid or hollow.*
4. *The optimum developed length, and resultant spliced diameter, of the seal can easily be validated in the application simply by evaluating a series of different spliced lengths in the assembly. This can not be accomplished with a molded product without a series of prototype tools.*

#### Venting

Spliced hollow profiles, when used in applications that require the periodic removal of compressive force, need to have the ability to rebound or return to their original form. When a spliced hollow profile is initially compressed, the air trapped inside the seal is also compressed. Depending upon the elastomer material, and wall (radial) seal thickness, the air may escape over a period of time. When the closure force is removed, the seal tries to recover, but can not because an internal vacuum has been created. The seal does not have the strength to draw external air back inside. To correct this problem and make it easier for the seal to rebound, vent holes can be built into the seal element itself. Vent holes typically located in an area that does not have a critical sealing function. This allows the seal to "breathe" when repeated opening and closing of an assembly is a functional requirement.

#### Twisting and Parting Lines

Molded products, while offering many benefits, also have inherent, process-related detriments. Examples of this include parting lines, voids, mismatch (off-registration), flash, etc.

Seal twisting can cause parting lines to position against the sealing surface, potentially creating a leak path and compromising sealing integrity.

TechSeal's process eliminates these manufacturing variables, since the seal profile is extruded and cured in long lengths. Round profiles have no parting lines at all. Profiles with at least one flat surface offer stability in the gland, and may also offer the option of PSA (Pressure Sensitive Adhesive) attachment.

### Compression-Deflection

Compression-Deflection information and expanded discussion of these properties are found on page 25.

### Basic TechSeal ParFab Elastomers

Following are brief descriptions of the most commonly used TechSeal ParFab elastomers. There are many other specialized polymers, and Parker TechSeal has developed formulations on most of them. Consult TechSeal for information on our complete line of available elastomer compounds.

#### **SILICONE RUBBER (Q, MQ, VMQ, PVMQ)**

The term silicone covers a large group of materials in which methyl-vinyl-silicone (VMQ) is often the central ingredient. Silicone elastomers as a group have relatively low tensile strength, poor tear and wear resistance. However, they have many useful properties as well. Silicones have good heat resistance up to 450°F (232°C), good cold flexibility down to -75°F (-59°C) and good ozone and weather resistance as well as good insulating and physiologically neutral properties.

#### Heat resistance

- Up to approximately 400°F (204°C) (special compounds up to 450°F (232°C)).

#### Cold flexibility

- Down to approximately -75°F to -65°F (-59°C to -54°C) with special compounds down to -175°F (-115°C).

#### Chemical resistance

- Fire-resistant hydraulic fluid, HFD-R and HFD-S.
- Water up to 212°F (100°C).
- Diluted salt solutions.
- Ozone.
- Aging.
- Weather resistant.

#### Not compatible with:

- Superheated water steam over 250°F (121°C).
- Acids and alkalis.
- Animal and vegetable oil and grease.
- Brake fluid (non-petroleum base).
- Low molecular weight chlorinated hydrocarbons (trichlorethylene).
- Aromatic mineral oil.
- Hydrocarbon based fuels.
- Aromatic hydrocarbons (benzene, toluene).

#### **ACRYLONITRILE-BUTADIENE (NITRILE) (NBR)**

Nitrile rubber (NBR) is the general term for acrylonitrile butadiene terpolymer. The acrylonitrile content of nitrile sealing compounds varies considerably (18 to 50%) and influences the physical properties of the finished material.

The *higher* the acrylonitrile content, the better the resistance to oil and fuel. At the same time, elasticity and resistance to compression set is adversely affected. In view of these opposing realities, a compromise is often drawn and a medium acrylonitrile content selected. NBR has good mechanical properties and high wear resistance when compared with other elastomers but is not resistant to weather and ozone.

#### Heat resistance

- Up to 212°F (100°C) with shorter life @ 250°F (121°C).

#### Cold flexibility

- Depending on individual compound, between -30°F (-34°C) and -70°F (-57°C).

#### Chemical resistance

- Aliphatic hydrocarbons (propane, butane, petroleum oil, mineral oil and grease, diesel fuel, fuel oils) vegetable and mineral oils and greases.
- HFA, HFB and HFC fluids.
- Dilute acids, alkali and salt solutions at low temperatures.
- Water Special compounds up to 212°F (100°C).

#### Not compatible with:

- Fuels of high aromatic content (for super fuels a special compound must be used).
- Aromatic hydrocarbons (benzene).
- Chlorinated hydrocarbons (trichlorethylene).
- Polar solvents (ketone, acetone, acetic acid, ethylene-ester).
- Strong acids.
- Brake fluid with glycol base.
- Ozone, weather and atmospheric aging.

#### **ETHYLENE PROPYLENE RUBBER (EPM, EPDM)**

EPM is a copolymer of ethylene and propylene. Ethylene-propylene-diene rubber (EPDM) is produced using a third monomer and is particularly useful when sealing phosphate-ester hydraulic fluids and in brake systems that use fluids having a glycol base.

#### Heat resistance

- Up to 250°F (121°C) (max. 400°F (204°C) in water and/ or steam).

#### Cold flexibility

- Down to approximately -70°F (-57°C)

#### Chemical resistance

- Hot water and steam up to 300°F (149°C) with special compounds up to 400°F (204°C)
- Brake fluids on glycol base up to +300°F (149°C).
- Many organic and inorganic acids.
- Cleaning agents, soda and potassium alkalis.
- Hydraulic fluids based on phosphate-ester (HFD-R).
- Silicone oil and grease.
- Many polar solvents (alcohols, ketones, esters).

- Skydrol 500 and 7000.
- Ozone, aging and weather resistant.

**Not compatible with:**

- Mineral oil products (oils, greases and fuels).

**FLUOROCARBON (FKM)**

Fluorocarbon (FKM) has excellent resistance to high temperatures, ozone, oxygen, mineral oil, synthetic hydraulic fluids, fuels, aromatics and many organic solvents and chemicals. Low temperature resistance is normally not favorable and for static applications is limited to approximately -15° F (-26° C) although in certain situations it is suitable down to -40° F (-40° C). Under dynamic conditions, the lowest temperature expected is between 5° F and 0° F (-15° C and -18° C).

- Gas permeability is very low and similar to that of butyl rubber. Special FKM compounds exhibit a higher resistance to acids, fuels, water and steam.

**Heat resistance**

- Up to 400° F (204° C) and higher temperatures with shorter life expectancy.

**Cold flexibility**

- Down to -15° F (-26° C) some to -40° F (-40° C).

**Chemical resistance**

- Mineral oil and grease, low swelling in ASTM oils No. 1 through No. 3.
- Non-flammable hydraulic fuels in the group HFD.
- Silicone oil and grease.
- Mineral and vegetable oil and grease.
- Aliphatic hydrocarbons (fuel, butane, propane, natural gas).
- Aromatic hydrocarbons (benzene, toluene).
- Chlorinated hydrocarbons (trichloroethylene and carbon tetrachloride).
- Fuels, also fuels with methanol content.
- High vacuum.
- Very good ozone, weather and aging resistance.

**Not compatible with:**

- Brake fluids with glycol base.
- Ammonia gas, amine, alkalis.
- Superheated steam.
- Low molecular organic acids (formic and acetic acids).

**FLUROSILICONE (FVMQ)**

FVMQ contains trifluoropropyl groups next to the methyl groups. The mechanical physical properties are very similar to VMQ. However, FVMQ offers improved fuel and mineral oil resistance but poor air resistance when compared with VMQ.

**Heat resistance**

- Up to 350° F (177° C) max.

**Cold flexibility**

- Down to approximately -100° F (-73° C).

**Chemical resistance**

- Aromatic mineral oils (IRM 903 oil).
- Fuels.
- Low molecular weight aromatic hydrocarbons (benzene, toluene).

**CHLOROPRENE (CR)**

Chloroprene was the first synthetic rubber developed commercially and exhibits generally good ozone, aging and chemical resistance. It has good mechanical properties over a wide temperature range.

**Heat resistance**

- Up to approximately 250° F (121° C).

**Cold flexibility**

- Down to approximately -40° F (-40° C).

**Chemical resistance**

- Paraffin base mineral oil with low DPI, e.g. ASTM oil No. 1.
- Silicone oil and grease.
- Water and water solvents at low temperatures.
- Refrigerants.
- Ammonia.
- Carbon dioxide.
- Improved ozone, weathering and aging resistance compared with NBR.

**Limited compatibility**

- Naphthalene based mineral oil (IRM 902 and IRM 903 oils).
- Low molecular aliphatic hydrocarbons (propane, butane, fuel).
- Glycol based brake fluids.

**Not compatible with:**

- Aromatic hydrocarbons (benzene).
- Chlorinated hydrocarbons (trichloroethylene).
- Polar solvents (ketones, esters, ethers, acetones).

**Note:** While this brochure contains the most popular materials for Spliced/Fabricated Products, TechSeal also has a range of other compounds with different colors, durometer, specifications available to be supplied as long length extrusions or fabricated products in the following materials: Silicone, Fluorosilicone, EPDM, Fluorocarbon, Nitrile, HNBR (HSN), and Neoprene with durometers ranging from 40 to 90 Shore A. Many TechSeal compounds comply with special requirements including: FDA White Listed Ingredients, USP Class VI, UL 94 HB, UL 94V-0, UL 157, Mil-Spec/QPL, ZZ-R-765, ASTM/SAE callouts and NSF registered compounds. Contact the TechSeal Division if you require materials other than the ones listed in this design guide.

Typical Fluid/Media Compatibility for ParFab Applications - Table 7

Fluid/Media	Silicone	Nitrile	EPDM	Fluorocarbon	Fluorosilicone	Chloroprene
Air, below 200°F (93°C)	Good	Good	Good	Good	Good	Good
200°F (93°C)	Good	Good	Good	Good	Good	Good
300°F (149°C)	Good	Fair	Fair	Good	Good	Fair
400°F (204°C)	Good	Poor	Poor	Good	Fair	Poor
500°F (260°C)	Good	Poor	Poor	Fair	Poor	Poor
ASTM Oil, No.1	Good	Good	Poor	Good	Good	Good
No.2	Poor	Good	Poor	Good	Good	Fair
No.3	Poor	Good	Poor	Good	Good	Poor
No.4	Poor	Fair	Poor	Good	Fair	Poor
Automatic Transmission Fluid	Poor	Good	Poor	Good	Good	Fair
Carbon Dioxide	Good	Good	Good	Good	Good	Good
Corn Oil	Good	Good	Fair	Good	Good	Poor
Hydraulic Fluids (Organic)	Fair	Good	Poor	Good	Good	Fair
Hydraulic Fluids (Phosphate Ester)	Poor	Poor	Good	Fair	Good	Fair
Hydrocarbon Fuels (Saturated)	Poor	Good	Poor	Good	Good	Fair
Ozone	Good	Poor	Good	Good	Good	Fair

Note that all recommended compounds are suggested only. Customers should always test any seal material under actual operating conditions. More detailed fluid media compatibility information may be obtained by contacting the Parker TechSeal Division.

### Underwriter's Laboratory (UL) Definitions

The Underwriter's Laboratory provides a testing and qualification service to quantify certain properties of silicone elastomer materials. The basic test criteria used by UL in testing TechSeal silicone compounds are shown below.

**UL94 V-0** is defined as the vertical burn rate in millimeters per minute of a material with a thickness less than 0.031" (0.79mm). Parker TechSeal compound S7395-60 will cease to burn after the ignition source is removed, will not glow under UL test conditions and will not have flaming particles or drops.

**UL94 HB** is the calculation of the linear burn rate in millimeters per minute. S7395-60, S7416-70 and 7310-70 do not have burn rates which exceed 75mm per minute for a thickness less than 0.059" (1.4mm) for S7416-70 and S7310-70 and 0.011" (0.27mm) for S7395-60

**UL157 JMLU2** - Parker TechSeal compounds S7395-60, S7426-60 and S7442-40 are UL157 JMLU2 listed and meet the UL requirements for tensile, durometer, elongation, all for original physical properties, and after heat aging. Additionally, UL listed materials must pass low-temperature brittleness, compression set and ozone exposure testing.



### Underwriter's Laboratory (UL) Listed TechSeal Silicone Materials

Compound Number	S7442-40	S7395-60	S7426-60*	S7310-70	S7416-70
UL 94 V-0		X (0.055") (1.4mm)			
UL 94HB		X (0.011") (.27mm)		X (0.059") (1.5mm)	X (0.059") (1.5mm)
UL 157 JMLU2	X	X	X		
UL50		X			
Low Temp. Brittleness	-67F (-55°C)	-85F (-65°C)	-67F (-55°C)	-67F (-55°C)	-65F (-55°C)

Minimum wall thickness approved by UL in parentheses.

\* UL listed as S7426U-60

**TechSeal Extrusion (Splicing & Fabrication) Standard Material Offering - Table 5**

**TechSeal Silicone Compounds**

Properties*	ASTM									
	Test Procedures	Tolerance	S7442	S7440	S7395	S7426	S7390	S7310	S7416	S7403
Color	N/A	N/A	Rust	Rust	Gray	Rust	Blue	Green	Rust	Rust
Hardness (Shore A)	D2240	±5	40	50	60	60	60	70	70	80
Tensile Strength (PSI)	D412	Min	1100	1050	450	900	1000	900	900	900
Elongation (%)	D412	Min	325	400	300	250	200	150	200	100
100% Modulus, PSI	-	-	150	200	250	300	200	400	250	400
Compression Set (%)	D395	Max								
22 hrs @ 100°C		-	10	15	15	10	10	15	10	10
70 hrs @ 150°C		-	25	20	50	20	20	60	25	30
22 hrs @ 177°C		-	30	30	30	30	25	50	30	25
UL Rating (1)	-	-	3	-	1,2,3	3	-	3	2	-

(1) 1 = UL94 V-0, 2 = UL94 HB, 3 = UL157 JMLU2

\*Unless otherwise noted, these are test values, from a limited number of samples and should not be used for establishing specific limitations

**TechSeal EPDM Compounds**

Properties*	ASTM							
	Test Procedure	Tolerance	E7110	E7001	E7736	E7871	E7972	E7885
Color	N/A	N/A	Black	Black	Black	Black	Black	Black
Hardness (Shore A)	D2240	±5	55	60	70	75	80	90
Tensile Strength (PSI)	D412	Min	1200	1800	2100	1900	1500	1700
Elongation (%)	D412	Min	400	350	200	200	125	150
100% Modulus, PSI	-	-	150	300	425	700	900	1000
Compression Set	D395	Max						
22 hrs @ 70°C		-	15	20	15	15	10	30
70 hrs @ 100°C		-	25	15	-	20	15	30

\*Unless otherwise noted, these are test values from a limited number of samples and should not be used for establishing specific limitations.

**TechSeal Nitrile Compounds**

Properties*	ASTM			
	Test Procedure	Tolerance	N7021	N7786
Color	N/A	N/A	Black	Black
Hardness (Shore A)	D2240	±5	70	80
Tensile Strength (PSI)	D412	Min	1500	2000
Elongation (%)	D412	Min	250	125
Modulus, PSI	-	-	500	1300
Compression Set	D395	Max		
22 hrs @ 100°C		-	25	35

**TechSeal Neoprene Compounds**

Properties*	ASTM		
	Test Procedure	Tolerance	C7025
Color	N/A	N/A	Black
Hardness (Shore A)	D2240	±5	80
Tensile Strength (PSI)	D412	Min	1500
Elongation (%)	D412	Min	150
100% Modulus, PSI	-	-	900
Compression Set	D395	Max	
22 hrs @ 100°C		-	25

\*Unless otherwise noted, these are test values from a limited number of samples and should not be used for establishing specific limitations.

**TechSeal Fluorocarbon Compounds**

Properties*	ASTM			
	Test Procedure	Tolerance	V7895	VA600
Color	N/A	N/A	Black	Black
Hardness (Shore A)	D2240	+/- 5	75	75
Tensile Strength (PSI)	D412	Min	1900	1800
Elongation (%)	D412	Min	175	150
100% Modulus, PSI	-	-	900	95
Compression Set	D395	Max		
22 hrs @ 23°C		-	15	-
22 hrs @ 177°C		-	15	20
22 hrs @ 200°C		-	10	-

**TechSeal Fluorosilicone Compounds**

Properties*	ASTM				
	Test Procedure	Tolerance	L7230	L7232	
Color			Blue	Green	
Hardness (Shore A)	D2240	+/-5	60	70	
Tensile Strength (PSI)	D412	min.	900	900	
Elongation (%)	D412	min.	175	175	
100% Modulus, PSI	-	-	400	400	
Compression Set	D395	max			
22 hrs @ 100°C		-	10	15	
70 hrs @ 150°C		-	25	25	
22 hrs @ 177°C		-	25	25	

\*Unless otherwise noted, these are test values from a limited number of samples and should not be used for establishing specific limitations.

Extrusion Manufacturing Cross-Sectional Tolerance Guidelines - Table 6

Silicone Compound	Color	Hardness	in. (.040 - .125)	(mm) (0.8)	in. (.126 - .190)	(mm) (3.20 - 4.83)	in. (.191 - .250)	(mm) (4.85 - 6.35)	in. (.251 - .300)	(mm) (6.38 - 7.62)	in. (.301 - .375)	(mm) (7.65 - 9.53)	in. (.376 - .500)	(mm) (9.55 - 12.70)	in. (.501 - .750)	(mm) (12.73 - 19.05)	in. (.751 - 1.000)	(mm) (19.08 - 25.40)
S7442	Rust	40	0.003	(0.08)	0.004	(0.10)	0.005	(0.13)	0.006	(0.15)	0.007	(0.18)	0.008	(0.20)	0.010	(0.25)	0.015	(0.38)
S7440	Rust	50	0.003	(0.08)	0.004	(0.10)	0.005	(0.13)	0.006	(0.15)	0.007	(0.18)	0.008	(0.20)	0.010	(0.25)	0.015	(0.38)
S7395	Gray	60	0.003	(0.08)	0.004	(0.10)	0.005	(0.13)	0.006	(0.15)	0.007	(0.18)	0.008	(0.20)	0.010	(0.25)	0.015	(0.38)
S7426	Rust	60	0.003	(0.08)	0.004	(0.10)	0.005	(0.13)	0.006	(0.15)	0.007	(0.18)	0.008	(0.20)	0.010	(0.25)	0.015	(0.38)
S7390	Blue	60	0.003	(0.08)	0.004	(0.10)	0.005	(0.13)	0.006	(0.15)	0.007	(0.18)	0.008	(0.20)	0.010	(0.25)	0.015	(0.38)
S7310	Green	70	0.003	(0.08)	0.004	(0.10)	0.005	(0.13)	0.006	(0.15)	0.007	(0.18)	0.008	(0.20)	0.010	(0.25)	0.015	(0.38)
S7416	Rust	70	0.003	(0.08)	0.004	(0.10)	0.005	(0.13)	0.006	(0.15)	0.007	(0.18)	0.008	(0.20)	0.010	(0.25)	0.015	(0.38)
S7403	Rust	80	0.003	(0.08)	0.004	(0.10)	0.005	(0.13)	0.006	(0.15)	0.007	(0.18)	0.008	(0.20)	0.010	(0.25)	0.015	(0.38)

Fluorosilicone Compound	Color	Hardness	in. (.040 - .125)	(mm) (1.02 - 3.18)	in. (.126 - .190)	(mm) (3.20 - 4.83)	in. (.191 - .250)	(mm) (4.85 - 6.35)	in. (.251 - .300)	(mm) (6.38 - 7.62)	in. (.301 - .375)	(mm) (7.65 - 9.53)	in. (.376 - .500)	(mm) (9.55 - 12.70)	in. (.501 - .750)	(mm) (12.73 - 19.05)	in. (.751 - 1.000)	(mm) (19.08 - 25.40)
L7230	Blue	60	0.003	(0.08)	0.004	(0.10)	0.005	(0.13)	0.006	(0.15)	0.007	(0.18)	0.008	(0.20)	0.010	(0.25)	0.015	(0.38)
L7232	Green	70	0.003	(0.08)	0.004	(0.10)	0.005	(0.13)	0.006	(0.15)	0.007	(0.18)	0.008	(0.20)	0.010	(0.25)	0.015	(0.38)

EPDM Compound	Color	Hardness	in. (.040 to .125)	(mm) (1.02 - 3.18)	in. (.126 to .210)	(mm) (3.20 - 5.33)	in. (.211 to .275)	(mm) (5.36 - 6.99)	in. (.276 to .437)	(mm) (7.01 - 11.10)	in. (.438 to .625)	(mm) (11.13 - 15.88)	in. (.626 to .750)	(mm) (15.9 - 19.05)
E7110	Black	55	0.005	(0.13)	0.005	(0.13)	0.007	(0.18)	0.010	(0.25)	0.012	(0.30)	0.015	(0.38)
E7001	Black	60	0.005	(0.13)	0.005	(0.13)	0.007	(0.18)	0.010	(0.25)	0.012	(0.30)	0.015	(0.38)
E7736	Black	70	0.005	(0.13)	0.005	(0.13)	0.007	(0.18)	0.010	(0.25)	0.010	(0.25)	0.010	(0.25)
E7871	Black	75	0.005	(0.13)	0.007	(0.18)	0.010	(0.25)	0.013	(0.29)	0.016	(0.40)	0.020	(0.50)
E7972	Black	75	0.005	(0.13)	0.005	(0.13)	0.007	(0.18)	0.010	(0.25)	0.010	(0.25)	0.010	(0.25)

Nitrile Compound	Color	Hardness	in. (.040 to .125)	(mm) (1.02 - 3.18)	in. (.126 to .210)	(mm) (3.20 - 5.33)	in. (.211 to .275)	(mm) (5.36 - 6.99)	in. (.276 to .437)	(mm) (7.01 - 11.10)	in. (.438 to .625)	(mm) (11.13 - 15.88)	in. (.626 to .750)	(mm) (15.9 - 19.05)
N7021	Black	70	0.005	(0.13)	0.005	(0.13)	0.007	(0.18)	0.008	(0.20)	0.009	(0.01)	0.010	(0.25)
N7786*	Black	80	0.005	(0.13)	0.005	(0.13)	0.007	(0.18)	0.008	(0.20)	0.009	(0.01)	0.010	(0.25)

\* HINBR

Neoprene Compound	Color	Hardness	in. (.040 to .125)	(mm) (1.02 - 3.18)	in. (.126 to .210)	(mm) (3.20 - 5.33)	in. (.211 to .275)	(mm) (5.36 - 6.99)	in. (.276 to .437)	(mm) (7.01 - 11.10)	in. (.438 to .625)	(mm) (11.13 - 15.88)	in. (.626 to .750)	(mm) (15.9 - 19.05)
C7025	Black	80	0.007	(0.18)	0.007	(0.18)	0.007	(0.18)	0.010	(0.25)	0.016	(0.40)	0.020	(0.50)

Fluorocarbon Compound	Color	Hardness	in. (.040 - .080)	(mm) (1.02 - 2.03)	in. (.081 - .118)	(mm) (2.06 - 3.00)	in. (.119 - .157)	(mm) (3.02 - 3.99)	in. (.158 - .210)	(mm) (4.01 - 5.33)	in. (.211 - .295)	(mm) (5.36 - 7.49)	in. (.296 - .335)	(mm) (7.52 - 8.51)	in. (.336 - .393)	(mm) (8.53 - 9.98)
V7895	Black	75	0.004	(0.10)	0.005	(0.13)	0.006	(0.15)	0.008	(0.20)	0.010	(0.25)	0.012	(0.30)	0.014	(0.36)
VA600	Black	75	0.004	(0.10)	0.005	(0.13)	0.006	(0.15)	0.008	(0.20)	0.010	(0.25)	0.012	(0.30)	0.014	(0.36)

Note: Fluorocarbon tolerance ranges are based on solid or hollow-O cross-sections. Please contact TechSeal for tolerances on other fluorocarbon profiles or if special tolerances are required.



How to Specify a Standard TechSeal Part Number

X XXX X XXXXX

Typical TechSeal Ten-Digit Part Number.

1<sup>st</sup> Digit = Profile Configuration

2<sup>nd</sup> thru 4<sup>th</sup> Digit = Configuration Size (See Pages 13-19)

5<sup>th</sup> Digit = Description (PSA Backing, Spooled, Coiled, etc.)

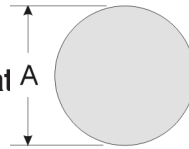
5<sup>th</sup> Digit Description - Alpha #

Alpha #	Description
C	Coiled Footage
L	Cut-to-Length
P	PSA Backing Spooled Footage
Q	PSA Backing Coiled Footage
S	Spooled Footage
X	Used for Splicing/Fabrication
6 <sup>th</sup> through 10 <sup>th</sup> Digit	= Elastomer Material

EXAMPLE: A001SS7442

Part Number A001SS7442 would indicate a Solid-O profile of .040 ± .003in. (1.102 ± 0.08mm) cross-section, supplied on spools and produced from TechSeal compound S7442-40 which is a 40 Shore A durometer silicone. All cross-sectional tolerances are material dependent, please see Table 6 for guidelines.

Solid "O" Cord Profiles  
TechSeal Configuration "A" Designat  
Table 10

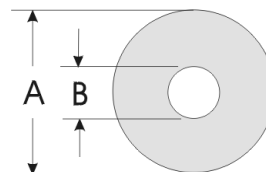


TechSeal Profile Part Number	A - Nominal Outside Diameter		Groove Depth		Groove Width (Inches)									
	inches	(mm)	Min	Max	Vacuum & Gases		Liquids							
			inches	(mm)	Min	Max	Min	Max	Min	Max				
A001XXXXXX	0.040	(1.02)	0.029	(0.73)	0.031	(0.78)	0.053	(1.35)	0.058	(1.48)	0.059	(1.51)	0.065	(1.66)
A002XXXXXX	0.048	(1.22)	0.034	(0.88)	0.037	(0.94)	0.062	(1.58)	0.067	(1.71)	0.070	(1.77)	0.076	(1.92)
A003XXXXXX	0.050	(1.27)	0.036	(0.91)	0.039	(0.98)	0.065	(1.64)	0.070	(1.77)	0.072	(1.84)	0.078	(1.99)
A004XXXXXX	0.053	(1.35)	0.038	(0.97)	0.041	(1.04)	0.068	(1.73)	0.073	(1.86)	0.076	(1.93)	0.082	(2.09)
A005XXXXXX	0.060	(1.52)	0.043	(1.09)	0.046	(1.18)	0.076	(1.93)	0.081	(2.06)	0.085	(2.16)	0.091	(2.31)
A006XXXXXX	0.062	(1.57)	0.045	(1.13)	0.048	(1.21)	0.078	(1.99)	0.083	(2.12)	0.088	(2.23)	0.094	(2.38)
A007XXXXXX	0.070	(1.78)	0.050	(1.28)	0.054	(1.37)	0.088	(2.23)	0.093	(2.35)	0.098	(2.49)	0.104	(2.64)
A008XXXXXX	0.075	(1.91)	0.054	(1.37)	0.058	(1.47)	0.093	(2.37)	0.098	(2.50)	0.104	(2.65)	0.110	(2.80)
A009XXXXXX	0.079	(2.01)	0.057	(1.45)	0.061	(1.55)	0.098	(2.49)	0.103	(2.61)	0.109	(2.78)	0.115	(2.93)
A010XXXXXX	0.085	(2.16)	0.061	(1.55)	0.066	(1.67)	0.105	(2.66)	0.110	(2.79)	0.117	(2.98)	0.123	(3.13)
A011XXXXXX	0.090	(2.29)	0.065	(1.65)	0.069	(1.76)	0.111	(2.81)	0.116	(2.94)	0.124	(3.14)	0.130	(3.29)
A012XXXXXX	0.093	(2.36)	0.067	(1.70)	0.072	(1.82)	0.114	(2.90)	0.119	(3.02)	0.127	(3.24)	0.133	(3.39)
A013XXXXXX	0.103	(2.62)	0.074	(1.88)	0.079	(2.02)	0.126	(3.19)	0.131	(3.32)	0.140	(3.56)	0.146	(3.72)
A014XXXXXX	0.112	(2.84)	0.080	(2.03)	0.086	(2.19)	0.136	(3.45)	0.141	(3.58)	0.152	(3.86)	0.158	(4.01)
A015XXXXXX	0.118	(3.00)	0.085	(2.15)	0.091	(2.31)	0.143	(3.63)	0.148	(3.75)	0.160	(4.05)	0.166	(4.21)
A016XXXXXX	0.125	(3.18)	0.090	(2.29)	0.096	(2.45)	0.151	(3.83)	0.156	(3.96)	0.169	(4.28)	0.175	(4.43)
A017XXXXXX	0.130	(3.30)	0.093	(2.36)	0.100	(2.55)	0.157	(3.98)	0.162	(4.10)	0.175	(4.45)	0.181	(4.60)
A018XXXXXX	0.139	(3.53)	0.101	(2.57)	0.107	(2.72)	0.167	(4.25)	0.172	(4.38)	0.187	(4.75)	0.197	(5.01)
A019XXXXXX	0.147	(3.73)	0.107	(2.72)	0.117	(2.97)	0.176	(4.48)	0.181	(4.61)	0.197	(5.01)	0.207	(5.26)
A020XXXXXX	0.156	(3.96)	0.113	(2.88)	0.123	(3.13)	0.187	(4.74)	0.192	(4.87)	0.209	(5.30)	0.219	(5.55)
A021XXXXXX	0.177	(4.50)	0.129	(3.27)	0.139	(3.52)	0.211	(5.35)	0.216	(5.48)	0.235	(5.98)	0.245	(6.23)
A022XXXXXX	0.188	(4.78)	0.137	(3.48)	0.147	(3.72)	0.223	(5.67)	0.228	(5.79)	0.249	(6.33)	0.259	(6.59)
A023XXXXXX	0.197	(5.0)	0.143	(3.63)	0.153	(3.89)	0.233	(5.93)	0.238	(6.05)	0.261	(6.62)	0.271	(6.88)
A024XXXXXX	0.210	(5.33)	0.152	(3.86)	0.162	(4.11)	0.251	(6.39)	0.256	(6.51)	0.281	(7.14)	0.291	(7.39)
A025XXXXXX	0.220	(5.59)	0.159	(4.04)	0.169	(4.30)	0.263	(6.68)	0.268	(6.80)	0.294	(7.46)	0.304	(7.72)
A026XXXXXX	0.236	(5.99)	0.171	(4.34)	0.181	(4.59)	0.281	(7.14)	0.286	(7.27)	0.314	(7.98)	0.324	(8.23)
A027XXXXXX	0.250	(6.35)	0.183	(4.64)	0.193	(4.90)	0.294	(7.47)	0.299	(7.60)	0.329	(8.35)	0.339	(8.61)
A028XXXXXX	0.275	(6.99)	0.201	(5.10)	0.211	(5.36)	0.325	(8.25)	0.330	(8.38)	0.363	(9.22)	0.373	(9.47)
A029XXXXXX	0.282	(7.16)	0.206	(5.23)	0.216	(5.49)	0.333	(8.45)	0.338	(8.58)	0.372	(9.44)	0.382	(9.70)
A030XXXXXX	0.312	(7.92)	0.228	(5.79)	0.238	(6.05)	0.367	(9.31)	0.372	(9.44)	0.410	(10.41)	0.420	(10.66)
A031XXXXXX	0.324	(8.23)	0.237	(6.02)	0.247	(6.27)	0.380	(9.66)	0.385	(9.78)	0.425	(10.79)	0.435	(11.05)
A032XXXXXX	0.348	(8.84)	0.254	(6.45)	0.264	(6.71)	0.407	(10.35)	0.412	(10.47)	0.455	(11.56)	0.465	(11.82)
A033XXXXXX	0.375	(9.53)	0.276	(7.01)	0.286	(7.26)	0.437	(11.10)	0.442	(11.23)	0.489	(12.41)	0.499	(12.66)
A034XXXXXX	0.393	(9.98)	0.289	(7.34)	0.299	(7.60)	0.457	(11.62)	0.462	(11.74)	0.511	(12.98)	0.521	(13.24)
A035XXXXXX	0.429	(10.90)	0.316	(8.03)	0.326	(8.27)	0.498	(12.64)	0.503	(12.77)	0.556	(14.13)	0.566	(14.38)
A036XXXXXX	0.479	(12.17)	0.353	(8.97)	0.363	(9.21)	0.554	(14.07)	0.559	(14.20)	0.619	(15.72)	0.629	(15.98)
A037XXXXXX	0.500	(12.70)	0.370	(9.40)	0.380	(9.65)	0.577	(14.65)	0.582	(14.77)	0.644	(16.37)	0.654	(16.62)
A038XXXXXX	0.562	(14.27)	0.416	(10.57)	0.426	(10.82)	0.650	(16.52)	0.655	(16.65)	0.727	(18.46)	0.737	(18.72)
A039XXXXXX	0.635	(16.13)	0.470	(11.94)	0.480	(12.19)	0.732	(18.59)	0.737	(18.72)	0.818	(20.78)	0.828	(21.03)

NOTES: (1) All of the above part numbers are extrudable in Silicone materials.  
 (2) Smallest and largest sizes may not be extrudable in non-silicone materials. Contact the TechSeal Applications Engineering Department for more specific information.  
 (3) Tooling is available for any size O.D. from .040 through 1.000". Contact TechSeal for size availability on sizes not listed in the above table.

MATERIALS

**Hollow “O” Profiles**  
**TechSeal Configuration “B” Designation**  
**Table 11**



TechSeal Profile Part Number	Nominal A		Nominal B		Groove Depth				Groove Width			
	Outside Diameter		Inside Diameter		Min		Max		Min		Max	
	inches	(mm)	inches	(mm)	inches	(mm)	inches	(mm)	inches	(mm)	inches	(mm)
<b>B001</b> XXXXXX	0.040	(1.02)	0.015	(0.38)	0.029	(0.73)	0.031	(0.78)	0.053	(1.35)	0.058	(1.48)
<b>B002</b> XXXXXX	0.053	(1.35)	0.027	(0.69)	0.038	(0.97)	0.041	(1.04)	0.068	(1.73)	0.073	(1.86)
<b>B003</b> XXXXXX	0.062	(1.57)	0.035	(0.89)	0.045	(1.13)	0.048	(1.21)	0.078	(1.99)	0.083	(2.12)
<b>B004</b> XXXXXX	0.070	(1.78)	0.030	(0.76)	0.050	(1.28)	0.054	(1.37)	0.088	(2.23)	0.093	(2.35)
<b>B005</b> XXXXXX	0.070	(1.78)	0.040	(1.02)	0.050	(1.28)	0.054	(1.37)	0.088	(2.23)	0.093	(2.35)
<b>B006</b> XXXXXX	0.073	(1.85)	0.043	(1.09)	0.052	(1.33)	0.056	(1.43)	0.091	(2.31)	0.096	(2.44)
<b>B007</b> XXXXXX	0.083	(2.11)	0.043	(1.09)	0.060	(1.51)	0.064	(1.63)	0.103	(2.60)	0.108	(2.73)
<b>B008</b> XXXXXX	0.083	(2.11)	0.050	(1.27)	0.060	(1.51)	0.064	(1.63)	0.103	(2.60)	0.108	(2.73)
<b>B009</b> XXXXXX	0.090	(2.29)	0.050	(1.27)	0.065	(1.64)	0.069	(1.76)	0.111	(2.81)	0.116	(2.94)
<b>B010</b> XXXXXX	0.103	(2.62)	0.040	(1.02)	0.074	(1.88)	0.079	(2.02)	0.126	(3.19)	0.131	(3.32)
<b>B011</b> XXXXXX	0.103	(2.62)	0.062	(1.57)	0.074	(1.88)	0.079	(2.02)	0.126	(3.19)	0.131	(3.32)
<b>B012</b> XXXXXX	0.118	(3.0)	0.079	(2.01)	0.085	(2.15)	0.091	(2.31)	0.143	(3.63)	0.148	(3.75)
<b>B013</b> XXXXXX	0.125	(3.18)	0.062	(1.57)	0.090	(2.29)	0.096	(2.45)	0.151	(3.83)	0.156	(3.96)
<b>B014</b> XXXXXX	0.125	(3.18)	0.080	(2.03)	0.090	(2.29)	0.096	(2.45)	0.151	(3.83)	0.156	(3.96)
<b>B015</b> XXXXXX	0.139	(3.53)	0.070	(1.78)	0.101	(2.57)	0.107	(2.72)	0.167	(4.25)	0.172	(4.38)
<b>B016</b> XXXXXX	0.156	(3.96)	0.050	(1.27)	0.113	(2.88)	0.123	(3.13)	0.187	(4.74)	0.192	(4.87)
<b>B017</b> XXXXXX	0.156	(3.96)	0.096	(2.44)	0.113	(2.88)	0.123	(3.13)	0.187	(4.74)	0.192	(4.87)
<b>B018</b> XXXXXX	0.177	(4.50)	0.077	(1.96)	0.129	(3.27)	0.139	(3.52)	0.211	(5.35)	0.216	(5.48)
<b>B019</b> XXXXXX	0.177	(4.50)	0.127	(3.23)	0.129	(3.27)	0.139	(3.52)	0.211	(5.35)	0.216	(5.48)
<b>B020</b> XXXXXX	0.210	(5.33)	0.100	(2.54)	0.152	(3.86)	0.162	(4.11)	0.251	(6.39)	0.256	(6.51)
<b>B021</b> XXXXXX	0.210	(5.33)	0.150	(3.81)	0.152	(3.86)	0.162	(4.11)	0.251	(6.39)	0.256	(6.51)
<b>B022</b> XXXXXX	0.250	(6.35)	0.125	(3.18)	0.183	(4.64)	0.193	(4.90)	0.294	(7.47)	0.299	(7.60)
<b>B023</b> XXXXXX	0.250	(6.35)	0.170	(4.32)	0.183	(4.64)	0.193	(4.90)	0.294	(7.47)	0.299	(7.60)
<b>B024</b> XXXXXX	0.312	(7.92)	0.192	(4.88)	0.228	(5.79)	0.238	(6.05)	0.367	(9.31)	0.372	(9.44)
<b>B025</b> XXXXXX	0.375	(9.53)	0.250	(6.35)	0.276	(7.01)	0.286	(7.26)	0.437	(11.10)	0.442	(11.23)
<b>B026</b> XXXXXX	0.500	(12.70)	0.380	(9.65)	0.370	(9.40)	0.380	(9.65)	0.577	(14.65)	0.582	(14.77)

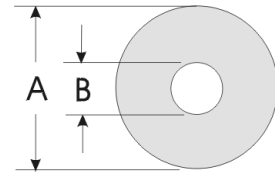
NOTES: (1) All of the above part numbers are extrudable in Silicone materials.  
(2) Smallest and largest sizes may not be extrudable in non-silicone materials. Contact the TechSeal Applications Engineering Department for more specific information.  
(3) Tooling is available for any size Hollow-O O.D. from .040 through 1.000". Some limitations do exist for minimal wall dimensions Contact TechSeal for size availability.  
(4) Refer to page 13 for information on how to specify a TechSeal part number and further description of XXXXXX digits.

PROFILES



**Hollow “O” Profiles**  
**TechSeal Configuration “B” Designation**  
**Friction Fit Series**

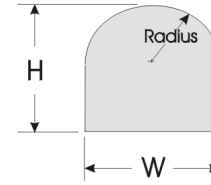
**Table 12**



TechSeal Profile Part Number	Nominal A		Nominal B		Groove Depth		Groove Width					
	Outside Diameter		Inside Diameter		Min	Max	Min		Max			
	inches	(mm)	inches	(mm)	inches	(mm)	inches	(mm)	inches	(mm)		
<b>B008XXXXXX</b>	0.083	(2.11)	0.050	(1.27)	0.056	(1.43)	0.060	(1.53)	0.071	(1.81)	0.075	(1.91)
<b>B009XXXXXX</b>	0.090	(2.29)	0.050	(1.27)	0.061	(1.55)	0.065	(1.65)	0.078	(1.99)	0.082	(2.09)
<b>B010XXXXXX</b>	0.103	(2.62)	0.040	(1.02)	0.076	(1.93)	0.080	(2.03)	0.096	(2.44)	0.100	(2.54)
<b>B011XXXXXX</b>	0.103	(2.62)	0.062	(1.57)	0.070	(1.78)	0.074	(1.88)	0.091	(2.32)	0.095	(2.42)
<b>B012XXXXXX</b>	0.118	(3.00)	0.079	(2.01)	0.081	(2.05)	0.085	(2.15)	0.106	(2.70)	0.110	(2.80)
<b>B013XXXXXX</b>	0.125	(3.18)	0.062	(1.57)	0.090	(2.29)	0.094	(2.39)	0.113	(2.88)	0.117	(2.98)
<b>B014XXXXXX</b>	0.125	(3.18)	0.080	(2.03)	0.086	(2.17)	0.090	(2.29)	0.113	(2.88)	0.117	(2.98)
<b>B015XXXXXX</b>	0.139	(3.53)	0.070	(1.78)	0.098	(2.49)	0.102	(2.57)	0.126	(3.20)	0.130	(3.30)
<b>B017XXXXXX</b>	0.156	(3.96)	0.096	(2.44)	0.107	(2.72)	0.111	(2.82)	0.139	(3.53)	0.143	(3.63)
<b>B018XXXXXX</b>	0.177	(4.50)	0.077	(1.96)	0.132	(3.35)	0.138	(3.51)	0.161	(4.09)	0.167	(4.24)
<b>B019XXXXXX</b>	0.177	(4.50)	0.127	(3.23)	0.121	(3.07)	0.127	(3.23)	0.159	(4.04)	0.165	(4.20)
<b>B020XXXXXX</b>	0.210	(5.33)	0.100	(2.54)	0.147	(3.71)	0.153	(3.89)	0.194	(4.93)	0.200	(5.08)
<b>B021XXXXXX</b>	0.210	(5.33)	0.150	(3.81)	0.144	(3.65)	0.150	(3.81)	0.192	(4.87)	0.198	(5.03)
<b>B022XXXXXX</b>	0.250	(6.35)	0.125	(3.18)	0.172	(4.37)	0.178	(4.53)	0.232	(5.89)	0.238	(6.05)
<b>B023XXXXXX</b>	0.250	(6.35)	0.170	(4.32)	0.172	(4.37)	0.178	(4.53)	0.232	(5.89)	0.238	(6.05)
<b>B024XXXXXX</b>	0.312	(7.92)	0.192	(4.88)	0.215	(5.47)	0.221	(5.63)	0.289	(7.33)	0.295	(7.49)
<b>B025XXXXXX</b>	0.375	(9.53)	0.250	(6.35)	0.260	(6.59)	0.266	(6.75)	0.352	(8.94)	0.358	(9.10)
<b>B026XXXXXX</b>	0.500	(12.70)	0.380	(9.65)	0.347	(8.81)	0.353	(8.97)	0.477	(12.11)	0.483	(12.27)

NOTES: (1) All of the above part numbers are extrudable in Silicone materials.  
(2) All Groove Dimensions are based on 30% Compression and 95% Gland Fill.  
(3) Smallest and largest sizes may not be extrudable in non-silicone materials. Contact the TechSeal Applications Engineering Department for more specific information.  
(4) Tooling is available for any size Hollow-O O.D. from .040 through 1.000". Some limitations do exist for minimal wall dimensions Contact TechSeal for size availability.  
(5) Refer to page 13 for information on how to specify a TechSeal part number and further description of XXXXXX digits.

**Solid “D” Profiles**  
**TechSeal Configuration “C” Designation**  
**Table 13**



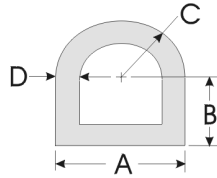
TechSeal Profile Part Number	Nominal Dimensions (Inches)						Suggested Groove Depth (Inches)		Suggested Groove Width (Inches)					
	H		W		R		Min	Max	Min	Max				
	inches	(mm)	inches	(mm)	inches	(mm)	inches	(mm)	inches	(mm)				
<b>C001XXXXXX</b>	0.064	(1.63)	0.055	(1.40)	0.031	(0.79)	0.050	(1.27)	0.054	(1.37)	0.078	(1.98)	0.082	(2.08)
<b>C002XXXXXX</b>	0.075	(1.91)	0.060	(1.52)	0.030	(0.76)	0.060	(1.52)	0.064	(1.63)	0.083	(2.11)	0.087	(2.21)
<b>C003XXXXXX</b>	0.068	(1.73)	0.062	(1.57)	0.031	(0.79)	0.054	(1.37)	0.058	(1.47)	0.086	(2.18)	0.090	(2.29)
<b>C004XXXXXX</b>	0.074	(1.88)	0.062	(1.57)	0.031	(0.79)	0.059	(1.50)	0.063	(1.60)	0.086	(2.18)	0.090	(2.29)
<b>C005XXXXXX</b>	0.085	(2.16)	0.062	(1.57)	0.031	(0.79)	0.070	(1.78)	0.074	(1.88)	0.086	(2.18)	0.090	(2.29)
<b>C006XXXXXX</b>	0.100	(2.54)	0.062	(1.57)	0.031	(0.79)	0.083	(2.11)	0.087	(2.21)	0.087	(2.21)	0.091	(2.31)
<b>C007XXXXXX</b>	0.055	(1.40)	0.064	(1.63)	0.032	(0.81)	0.042	(1.07)	0.046	(1.17)	0.090	(2.29)	0.094	(2.39)
<b>C008XXXXXX</b>	0.095	(2.41)	0.070	(1.78)	0.035	(0.89)	0.079	(2.01)	0.083	(2.11)	0.092	(2.34)	0.096	(2.44)
<b>C009XXXXXX</b>	0.089	(2.26)	0.078	(1.98)	0.039	(0.99)	0.072	(1.83)	0.076	(1.93)	0.103	(2.62)	0.107	(2.72)
<b>C010XXXXXX</b>	0.070	(1.78)	0.080	(2.03)	0.040	(1.02)	0.056	(1.42)	0.060	(1.52)	0.106	(2.69)	0.110	(2.79)
<b>C011XXXXXX</b>	0.090	(2.29)	0.080	(2.03)	0.040	(1.02)	0.074	(1.88)	0.078	(1.98)	0.111	(2.82)	0.115	(2.92)
<b>C012XXXXXX</b>	0.081	(2.06)	0.088	(2.24)	0.044	(1.12)	0.066	(1.68)	0.070	(1.78)	0.115	(2.92)	0.119	(3.02)
<b>C013XXXXXX</b>	0.134	(3.40)	0.091	(2.31)	0.045	(1.14)	0.115	(2.92)	0.119	(3.02)	0.121	(3.07)	0.125	(3.18)
<b>C014XXXXXX</b>	0.078	(1.98)	0.094	(2.39)	0.047	(1.19)	0.063	(1.60)	0.067	(1.70)	0.121	(3.07)	0.125	(3.18)
<b>C015XXXXXX</b>	0.094	(2.39)	0.094	(2.39)	0.047	(1.19)	0.078	(1.98)	0.082	(2.08)	0.122	(3.10)	0.126	(3.20)
<b>C016XXXXXX</b>	0.115	(2.92)	0.102	(2.59)	0.051	(1.30)	0.097	(2.46)	0.101	(2.57)	0.134	(3.40)	0.138	(3.51)
<b>C017XXXXXX</b>	0.131	(3.33)	0.122	(3.10)	0.061	(1.55)	0.112	(2.84)	0.116	(2.95)	0.159	(4.04)	0.163	(4.14)
<b>C018XXXXXX</b>	0.156	(3.96)	0.156	(3.96)	0.078	(1.98)	0.135	(3.43)	0.139	(3.53)	0.197	(5.00)	0.201	(5.11)
<b>C019XXXXXX</b>	0.200	(5.08)	0.187	(4.75)	0.093	(2.36)	0.175	(4.45)	0.179	(4.55)	0.231	(5.87)	0.235	(5.97)
<b>C020XXXXXX</b>	0.188	(4.78)	0.188	(4.78)	0.094	(2.39)	0.164	(4.17)	0.168	(4.27)	0.231	(5.87)	0.235	(5.97)
<b>C033XXXXXX</b>	0.250	(6.35)	0.250	(6.35)	0.125	(3.18)	0.213	(5.40)	0.217	(5.50)	0.309	(7.85)	0.313	(7.95)
<b>C034XXXXXX</b>	0.312	(7.92)	0.312	(7.92)	0.156	(3.96)	0.265	(6.74)	0.269	(6.84)	0.386	(9.79)	0.390	(9.89)
<b>C035XXXXXX</b>	0.312	(7.92)	0.488	(12.40)	0.244	(6.20)	0.265	(6.74)	0.269	(6.84)	0.562	(14.28)	0.566	(14.38)
<b>C036XXXXXX</b>	0.500	(12.70)	0.502	(12.75)	0.025	(6.35)	0.425	(10.80)	0.429	(10.90)	0.619	(15.73)	0.623	(15.83)

**Pressure Sensitive Adhesive (PSA) is available on any TechSeal extrusion with a flat side minimum width of 0.125" (3.18 mm). Please contact TechSeal to obtain the modified part numbers.**

NOTES: (1) All of the above part numbers are extrudable in Silicone materials.  
 (2) Smallest and largest sizes may not be extrudable in non-silicone materials. Contact the TechSeal Applications Engineering Department for more specific information.  
 (3) Refer to page 13 for information on how to specify a TechSeal part number and further description of XXXXXX digits.

PROFILES

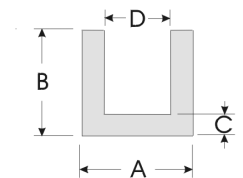
**Hollow “D” Profiles**  
**TechSeal Configuration “D” Designation**  
**Table 14**



TechSeal Profile Part Number	Nominal Dimensions			
	A inches (mm)	B inches (mm)	C (rad.) inches (mm)	D inches (mm)
D001XXXXXX	0.156 (3.96)	0.078 (1.98)	0.078 (1.98)	0.045 (1.14)
D002XXXXXX	0.187 (4.75)	0.093 (2.36)	0.093 (2.36)	0.050 (1.27)
D003XXXXXX	0.187 (4.75)	0.134 (3.40)	0.093 (2.36)	0.040 (1.02)
D004XXXXXX	0.207 (5.26)	0.084 (2.13)	0.103 (2.62)	0.050 (1.27)
D005XXXXXX	0.312 (7.92)	0.200 (5.08)	0.112 (2.84)	0.062 (1.57)
D006XXXXXX	0.250 (6.35)	0.125 (3.18)	0.125 (3.18)	0.062 (1.57)
D007XXXXXX	0.250 (6.35)	0.125 (3.18)	0.125 (3.18)	0.065 (1.65)
D008XXXXXX	0.296 (7.52)	0.150 (3.81)	0.172 (4.37)	0.050 (1.27)
D009XXXXXX	0.312 (7.92)	0.156 (3.96)	0.156 (3.96)	0.062 (1.57)
D010XXXXXX	0.488 (12.40)	0.068 (1.73)	0.244 (6.20)	0.055 (1.40)
D011XXXXXX	0.487 (12.37)	0.080 (2.03)	0.244 (6.20)	0.035 (0.89)
D012XXXXXX	0.487 (12.37)	0.080 (2.03)	0.244 (6.20)	0.045 (1.14)
D013XXXXXX	0.487 (12.37)	0.080 (2.03)	0.244 (6.20)	0.062 (1.57)
D014XXXXXX	0.487 (12.37)	0.080 (2.03)	0.244 (6.20)	0.080 (2.03)
D015XXXXXX	0.502 (12.75)	0.250 (6.35)	0.250 (6.35)	0.061 (1.55)
D016XXXXXX	0.700 (17.78)	0.250 (6.35)	0.350 (8.89)	0.100 (2.54)
D017XXXXXX	0.750 (19.05)	0.375 (9.53)	0.375 (9.53)	0.075 (1.91)
D018XXXXXX	0.975 (24.77)	0.132 (3.35)	0.488 (12.40)	0.093 (2.36)

**Please note: Total Height = B + C**

**U-Channel Profiles**  
**TechSeal Configuration “E” Designation**  
**Table 15**

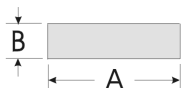


TechSeal Profile Part Number	Nominal Dimensions			
	A inches (mm)	B inches (mm)	C inches (mm)	D inches (mm)
E001XXXXXX	0.075 (1.91)	0.099 (2.51)	0.025 (0.64)	0.032 (0.81)
E002XXXXXX	0.100 (2.54)	0.100 (2.54)	0.034 (0.86)	0.033 (0.81)
E003XXXXXX	0.126 (3.20)	0.078 ((1.98)	0.044 (1.12)	0.048 (1.22)
E004XXXXXX	0.126 (3.20)	0.099 (2.51)	0.047 (1.19)	0.059 (1.50)
E005XXXXXX	0.126 (3.20)	0.097 (2.46)	0.026 (0.66)	0.037 (0.94)
E006XXXXXX	0.126 (3.20)	0.110 (2.79)	0.025 (0.64)	0.050 (1.27)
E007XXXXXX	0.126 (3.20)	0.225 (5.72)	0.020 (0.51)	0.075 (1.91)
E008XXXXXX	0.154 (3.91)	0.154 (3.91)	0.082 (2.08)	0.088 (2.24)
E009XXXXXX	0.154 (3.91)	0.156 (1.57)	0.062 (1.57)	0.040 (1.02)
E010XXXXXX	0.156 (3.96)	0.175 (4.45)	0.046 (1.17)	0.075 (1.91)
E011XXXXXX	0.175 (4.45)	0.156 (3.96)	0.047 (1.19)	0.075 (1.91)
E012XXXXXX	0.188 (4.78)	0.188 (4.78)	0.062 (1.57)	0.062 (1.57)
E013XXXXXX	0.193 (4.90)	0.193 (4.90)	0.128 (3.25)	0.064 (1.63)
E014XXXXXX	0.250 (6.35)	0.250 (6.35)	0.170 (4.32)	0.062 (1.57)
E015XXXXXX	0.250 (6.35)	0.250 (6.35)	0.130 (3.30)	0.062 (1.57)
E016XXXXXX	0.260 (6.60)	0.184 (4.67)	0.140 (3.56)	0.062 (1.57)
E017XXXXXX	0.320 (8.13)	0.315 (8.00)	0.193 (4.90)	0.197 (5.00)
E018XXXXXX	0.327 (8.31)	0.235 (5.97)	0.062 (1.57)	0.115 (2.92)
E019XXXXXX	0.375 (9.53)	0.500 (12.70)	0.187 (4.75)	0.125 (3.18)
E020XXXXXX	0.500 (12.70)	0.500 (12.70)	0.250 (6.35)	0.125 (3.18)

**Pressure Sensitive Adhesive (PSA) is available on any TechSeal extrusion with a flat side minimum width of 0.125” (3.18 mm). Please contact TechSeal to obtain the modified part numbers.**

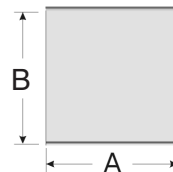
NOTES: (1) All of the above part numbers are extrudable in Silicone materials.  
 (2) Smallest and largest sizes may not be extrudable in non-silicone materials. Contact the TechSeal Applications Engineering Department for more specific information.  
 (3) Refer to page 13 for information on how to specify a TechSeal part number and further description of XXXXXX digits.

**Rectangular Strip Profiles**  
**TechSeal Configuration “F” Designation**  
**Table 16**



TechSeal Profile Part Number	Nominal Dimensions	
	A inches (mm)	B inches (mm)
F001XXXXXX	0.095 (2.41)	0.062 (1.57)
F002XXXXXX	0.125 (3.18)	0.062 (1.57)
F003XXXXXX	0.156 (3.96)	0.062 (1.57)
F004XXXXXX	0.188 (4.78)	0.062 (1.57)
F005XXXXXX	0.250 (6.35)	0.062 (1.57)
F006XXXXXX	0.500 (12.70)	0.062 (1.57)
F007XXXXXX	0.569 (14.45)	0.062 (1.57)
F008XXXXXX	0.750 (19.05)	0.062 (1.57)
F009XXXXXX	0.880 (22.35)	0.062 (1.57)
F010XXXXXX	1.000 (25.40)	0.062 (1.57)
F011XXXXXX	0.120 (3.05)	0.075 (1.91)
F012XXXXXX	0.250 (6.35)	0.075 (1.91)
F013XXXXXX	0.500 (12.70)	0.075 (1.91)
F014XXXXXX	0.125 (3.18)	0.093 (2.36)
F015XXXXXX	0.188 (4.78)	0.093 (2.36)
F016XXXXXX	0.250 (6.35)	0.093 (2.36)
F017XXXXXX	0.500 (12.70)	0.093 (2.36)
F018XXXXXX	0.170 (4.32)	0.125 (3.18)
F019XXXXXX	0.250 (6.35)	0.125 (3.18)
F020XXXXXX	0.500 (12.70)	0.125 (3.18)
F021XXXXXX	0.750 (19.05)	0.125 (3.18)
F022XXXXXX	1.000 (25.40)	0.125 (3.18)
F023XXXXXX	0.500 (12.70)	0.188 (4.78)
F024XXXXXX	0.500 (12.70)	0.250 (6.35)
F025XXXXXX	1.000 (25.40)	0.250 (6.35)

**Solid Square Profiles**  
**TechSeal Configuration “G” Designation**  
**Table 17**

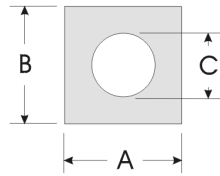


TechSeal Profile Part Number	Nominal Dimensions	
	A inches (mm)	B inches (mm)
G001XXXXXX	0.053 (1.35)	0.053 (1.53)
G002XXXXXX	0.066 (1.68)	0.066 (1.68)
G003XXXXXX	0.070 (1.78)	0.070 (1.78)
G004XXXXXX	0.099 (2.51)	0.099 (2.51)
G005XXXXXX	0.103 (2.62)	0.103 (2.62)
G006XXXXXX	0.134 (3.40)	0.134 (3.40)
G007XXXXXX	0.139 (3.53)	0.139 (3.53)
G008XXXXXX	0.203 (5.16)	0.203 (5.16)
G009XXXXXX	0.210 (5.33)	0.210 (5.33)
G010XXXXXX	0.265 (6.73)	0.265 (6.73)
G011XXXXXX	0.275 (6.99)	0.275 (6.99)
G012XXXXXX	0.360 (9.14)	0.360 (9.14)
G013XXXXXX	0.375 (9.53)	0.375 (9.53)
G014XXXXXX	0.480 (12.19)	0.480 (12.19)
G015XXXXXX	0.500 (12.70)	0.500 (12.70)

**Pressure Sensitive Adhesive (PSA) is available on any TechSeal extrusion with a flat side minimum width of 0.125” (3.18 mm). Please contact TechSeal to obtain the modified part numbers.**

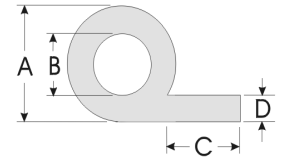
NOTES: (1) All of the above part numbers are extrudable in Silicone materials.  
 (2) Smallest and largest sizes may not be extrudable in non-silicone materials. Contact the TechSeal Applications Engineering Department for more specific information.  
 (3) Refer to page 13 for information on how to specify a TechSeal part number and further description of XXXXXX digits.  
 (4) Some configurations may have a degree of curvature, making them unsuitable in long lengths. Contact TechSeal Applications Engineering for details.

**Hollow Square Profiles**  
**TechSeal Configuration “H” Designation**  
**Table 18**



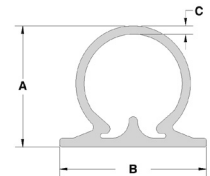
TechSeal Profile Part Number	Nominal Dimensions		
	A inches (mm)	B inches (mm)	C(dia.) inches (mm)
H001XXXXXX	0.053 (1.35)	0.053 (1.35)	0.020 (0.51)
H002XXXXXX	0.066 (1.68)	0.066 (1.68)	0.020 (0.51)
H003XXXXXX	0.070 (1.78)	0.070 (1.78)	0.025 (0.64)
H004XXXXXX	0.099 (2.51)	0.099 (2.51)	0.025 (0.64)
H005XXXXXX	0.103 (2.62)	0.103 (2.62)	0.025 (0.64)
H006XXXXXX	0.134 (3.40)	0.134 (3.40)	0.060 (1.52)
H007XXXXXX	0.139 (3.53)	0.139 (3.53)	0.060 (1.52)
H008XXXXXX	0.203 (5.16)	0.203 (5.16)	0.080 (2.03)
H009XXXXXX	0.210 (5.33)	0.210 (5.33)	0.080 (2.03)
H010XXXXXX	0.265 (6.73)	0.265 (6.73)	0.100 (2.54)
H011XXXXXX	0.275 (6.99)	0.275 (6.99)	0.100 (2.54)
H012XXXXXX	0.360 (9.14)	0.360 (9.14)	0.125 (3.18)
H013XXXXXX	0.375 (9.53)	0.375 (9.53)	0.125 (3.18)
H014XXXXXX	0.480 (12.19)	0.480 (12.19)	0.250 (6.35)
H015XXXXXX	0.500 (12.70)	0.500 (12.70)	0.250 (6.35)

**Hollow “P” Profiles**  
**TechSeal Configuration “P” Designation**  
**Table 19**



TechSeal Profile Part Number	Nominal Dimensions			
	A(dia.) inches (mm)	B(dia.) inches (mm)	C inches (mm)	D inches (mm)
P001XXXXXX	0.170 (4.32)	0.060 (1.52)	0.205 (5.21)	0.062 (1.57)
P002XXXXXX	0.200 (5.08)	0.080 (2.03)	0.250 (6.35)	0.062 (1.57)
P003XXXXXX	0.200 (5.08)	0.080 (2.03)	0.550 (13.97)	0.062 (1.57)
P004XXXXXX	0.250 (6.35)	0.125 (3.18)	0.250 (6.35)	0.062 (1.57)
P005XXXXXX	0.360 (9.14)	0.255 (6.48)	0.420 (10.67)	0.070 (1.78)
P006XXXXXX	0.600 (15.24)	0.400 (8.89)	0.350 (8.89)	0.110 (2.79)

**Omega Profiles**  
**TechSeal Configuration “W” Designation**  
**Table 20**



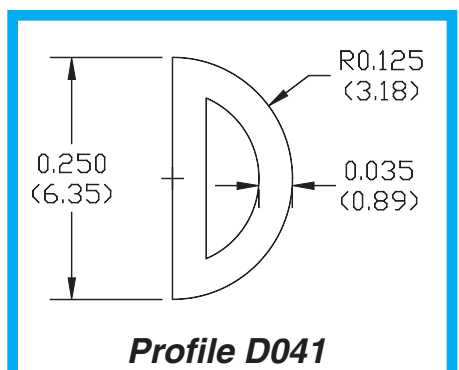
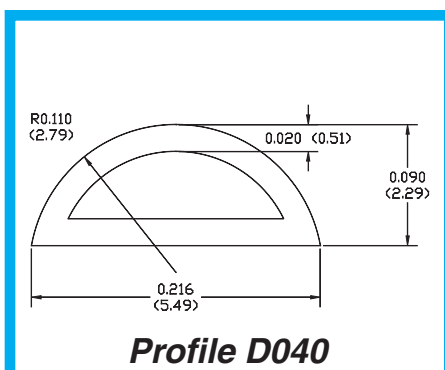
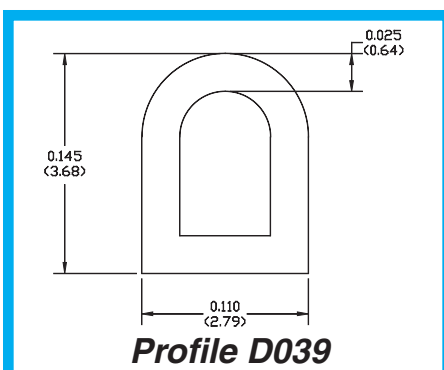
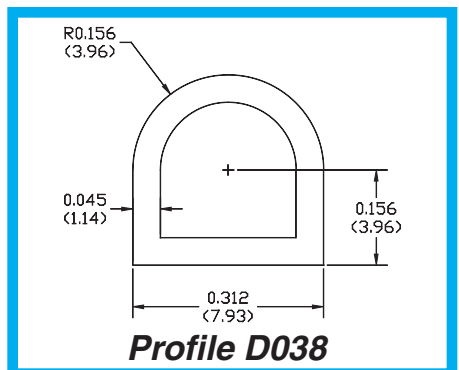
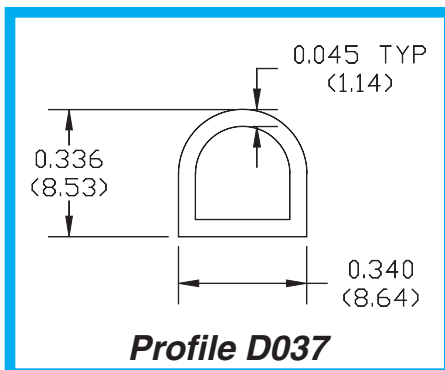
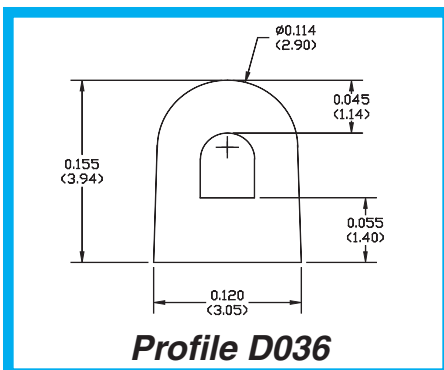
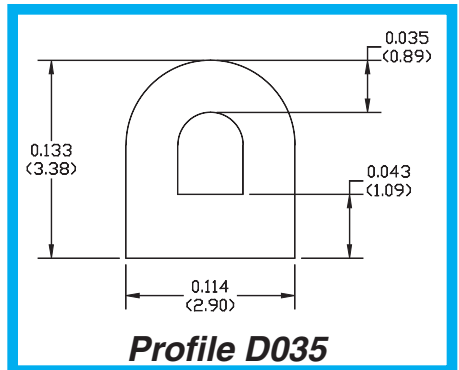
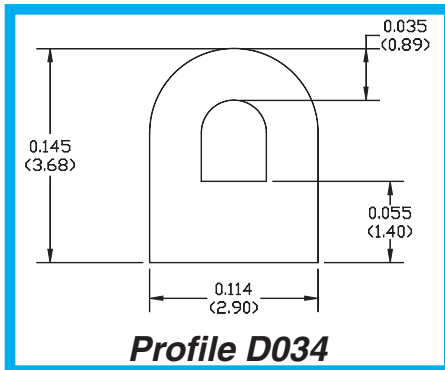
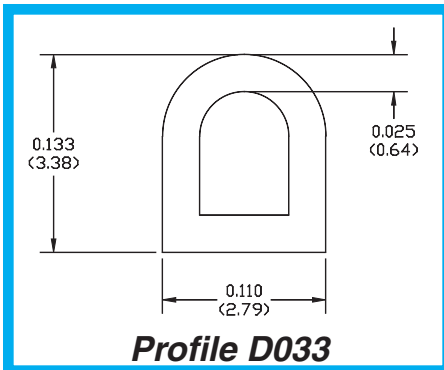
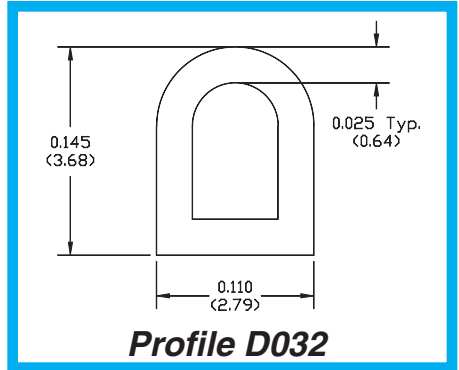
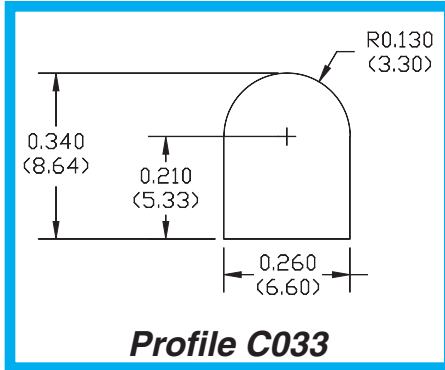
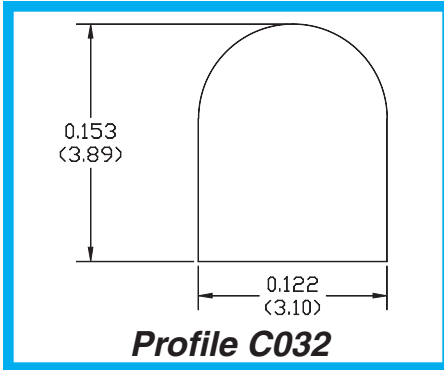
TechSeal Profile Part Number	Nominal Dimensions		
	A inches (mm)	B inches (mm)	C(dia.) inches (mm)
W016XXXXXX	0.728 (18.49)	0.890 (22.61)	0.065 (1.65)
W034XXXXXX	0.500 (12.70)	0.610 (15.49)	0.050 (1.27)
W059XXXXXX	0.250 (6.35)	0.330 (8.38)	0.050 (1.27)
W060XXXXXX	0.360 (9.14)	0.499 (12.67)	0.050 (1.27)
W061XXXXXX	0.360 (9.14)	0.499 (12.67)	0.070 (1.78)
W062XXXXXX	0.360 (9.14)	0.499 (12.67)	0.090 (2.29)
W063XXXXXX	0.360 (9.14)	0.490 (12.45)	0.080 (2.03)

**Pressure Sensitive Adhesive (PSA) is available on any TechSeal extrusion with a flat side minimum width of 0.125” (3.18 mm). Please contact TechSeal to obtain the modified part numbers.**

NOTES: (1) All of the above part numbers are extrudable in Silicone materials.  
 (2) Smallest and largest sizes may not be extrudable in non-silicone materials. Contact the TechSeal Applications Engineering Department for more specific information.  
 (3) Refer to page 13 for information on how to specify a TechSeal part number and further description of XXXXXX digits.

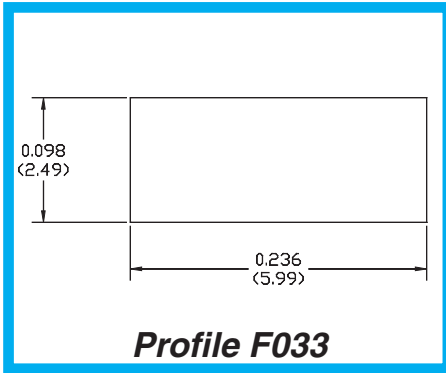
**TechSeal Custom Extruded Profiles**

Parker TechSeal supports its customers in the development of custom extruded profiles to solve specific application problems. The following drawings illustrate the wide range of custom extrusion capabilities of Parker TechSeal. If you are interested in using one of these shapes or want to discuss the development of an alternative design, please contact the TechSeal Applications Engineering Department. Note that most of these profiles are available in silicone and some may also be available in other polymers such as nitrile or ethylene propylene. Contact TechSeal for specific information.

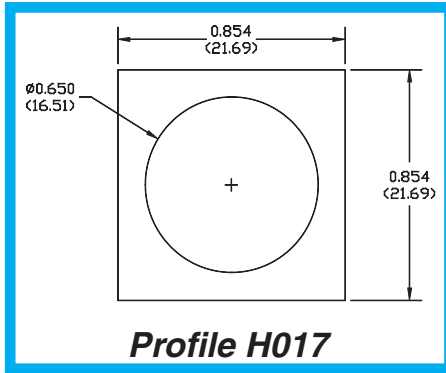


PROFILES

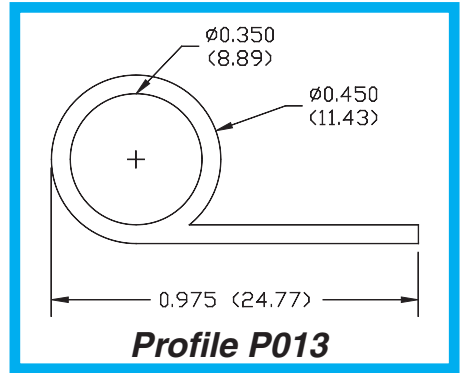
**TechSeal Custom Extruded Profiles**



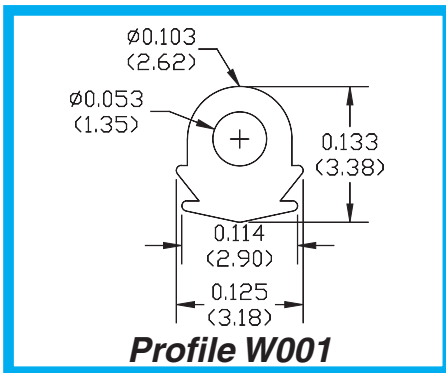
**Profile F033**



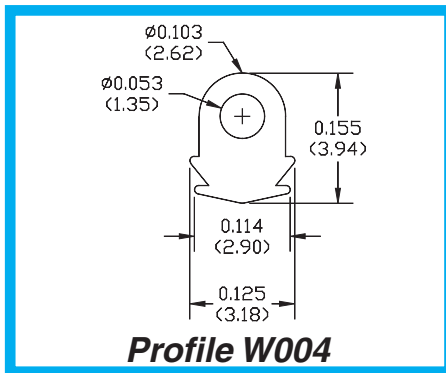
**Profile H017**



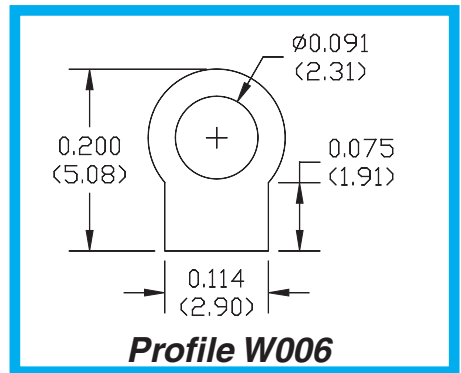
**Profile P013**



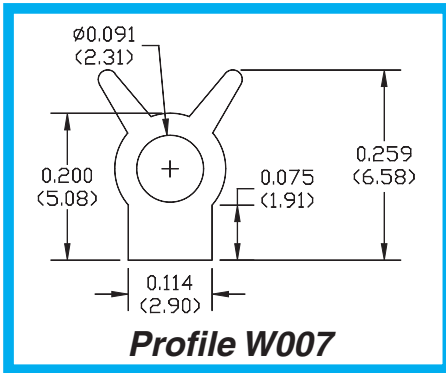
**Profile W001**



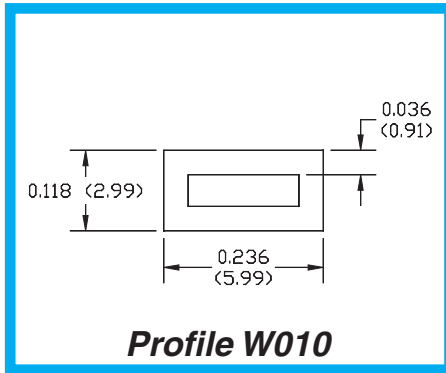
**Profile W004**



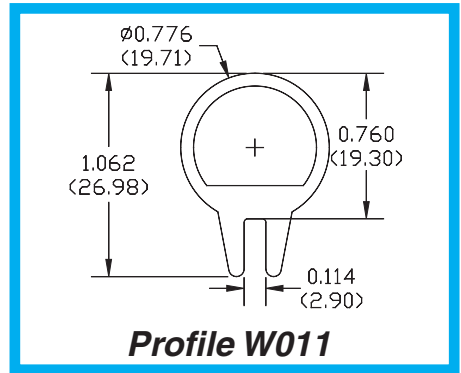
**Profile W006**



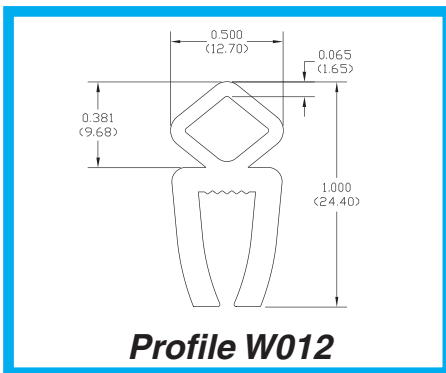
**Profile W007**



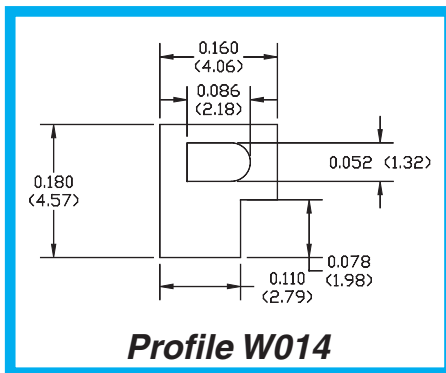
**Profile W010**



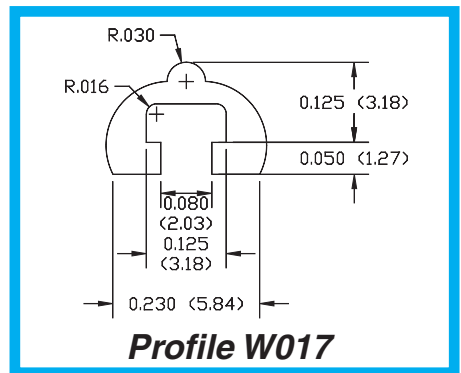
**Profile W011**



**Profile W012**



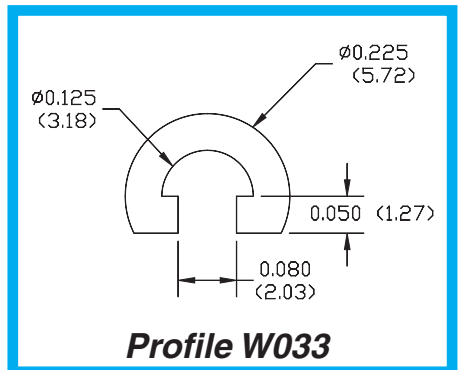
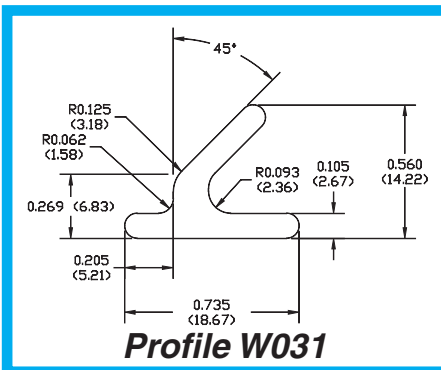
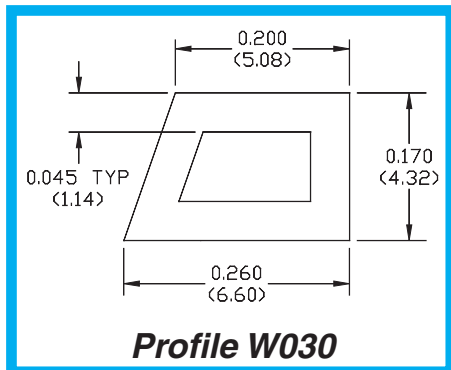
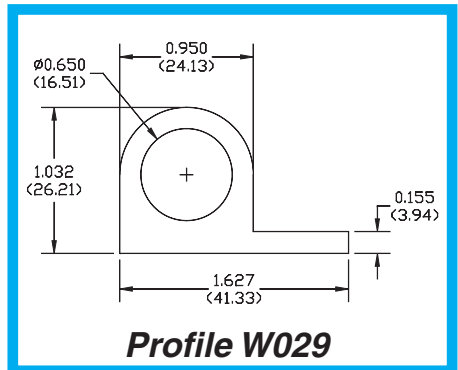
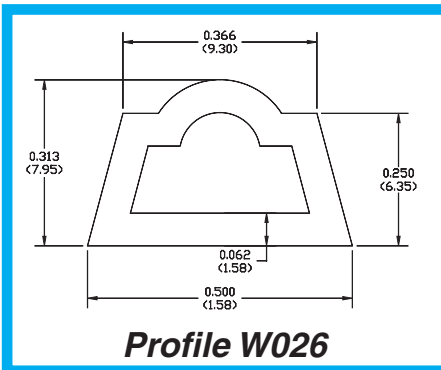
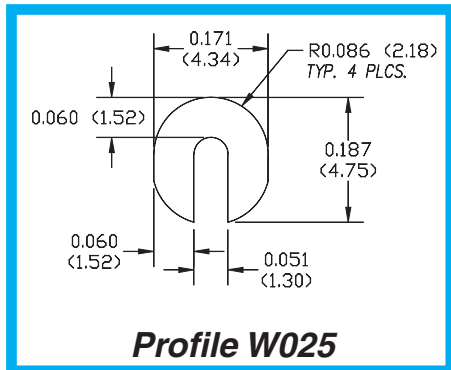
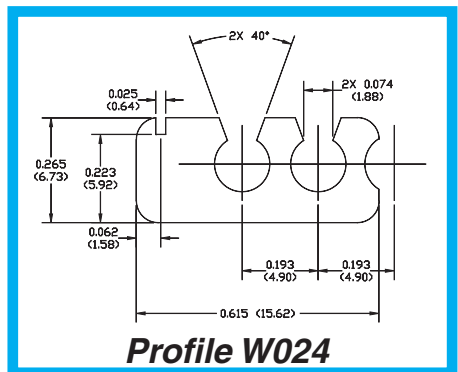
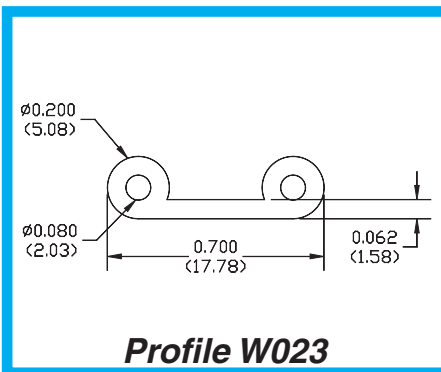
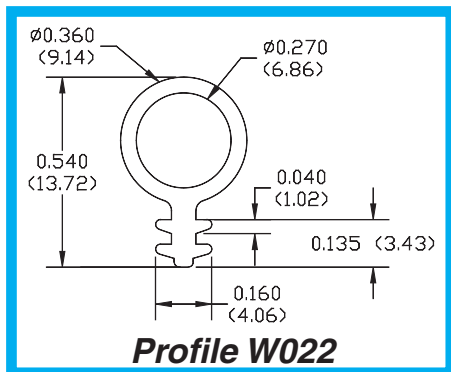
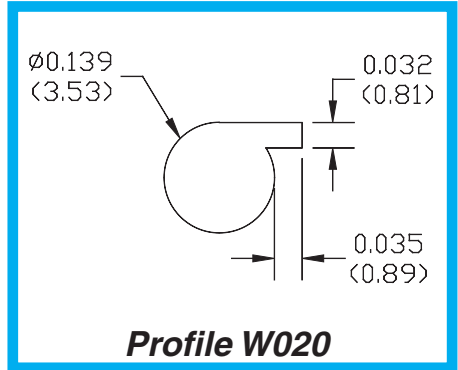
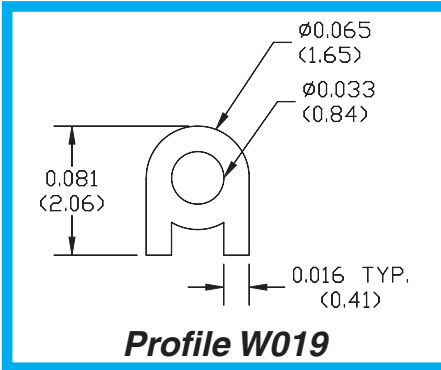
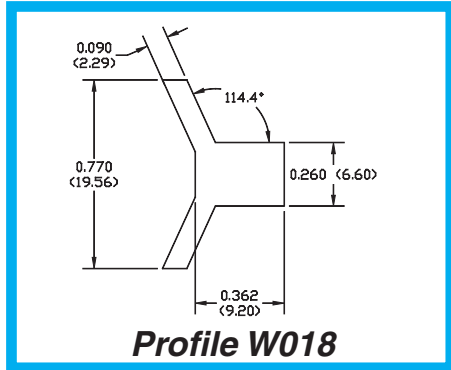
**Profile W014**



**Profile W017**

**PROFILES**

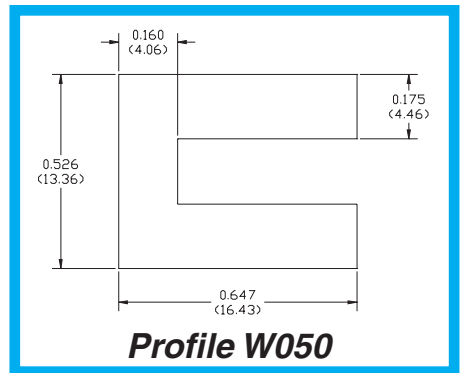
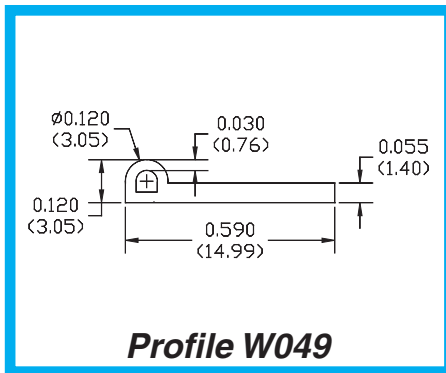
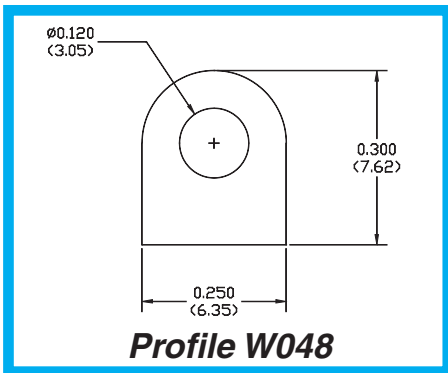
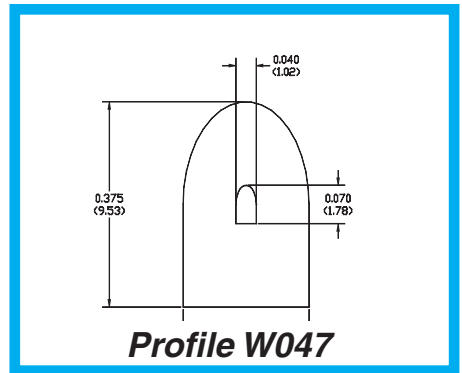
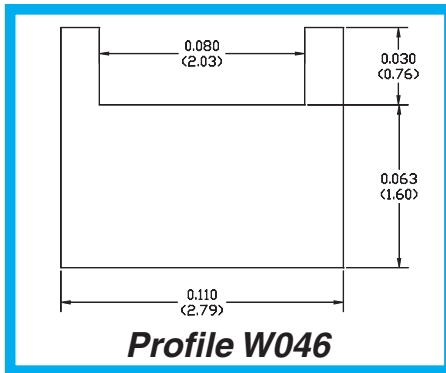
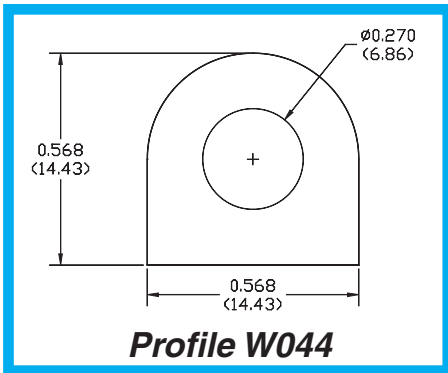
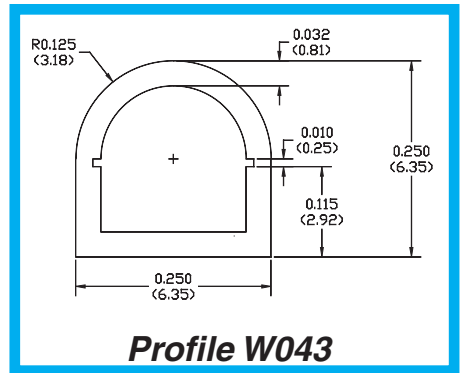
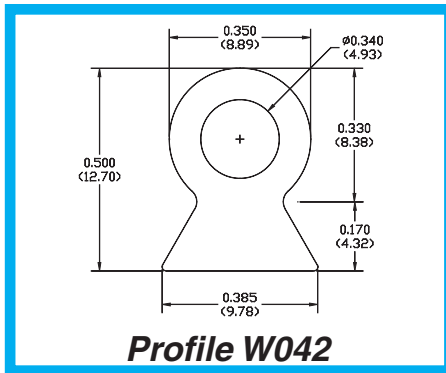
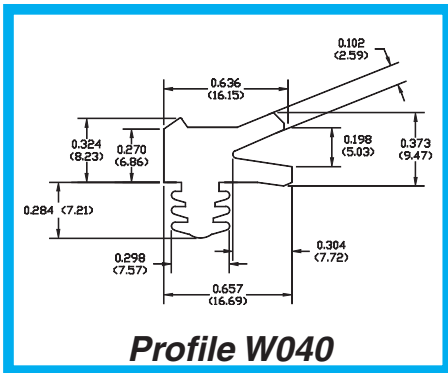
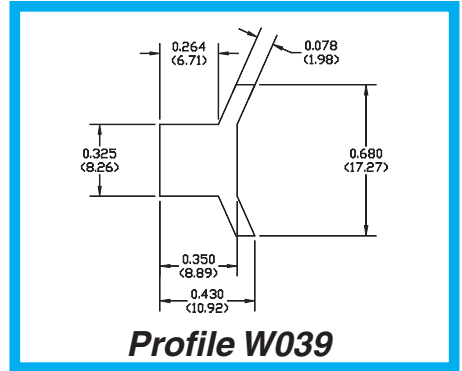
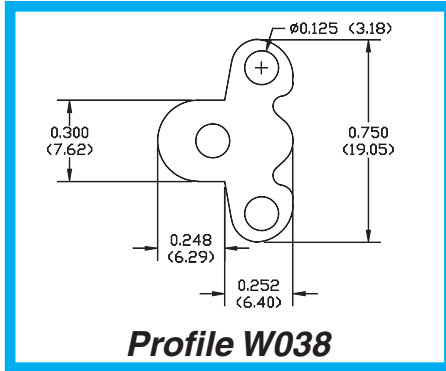
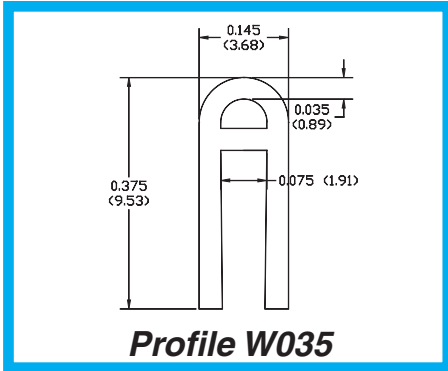
**TechSeal Custom Extruded Profiles**



PROFILES

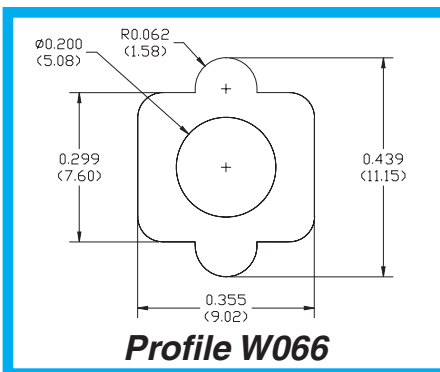
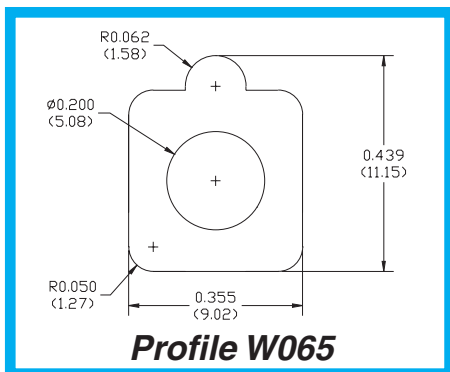
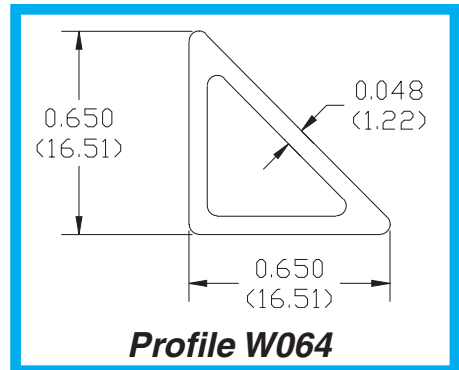
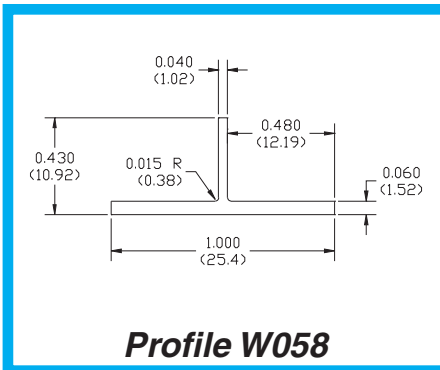
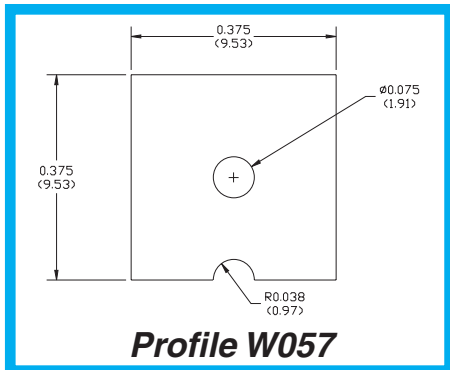
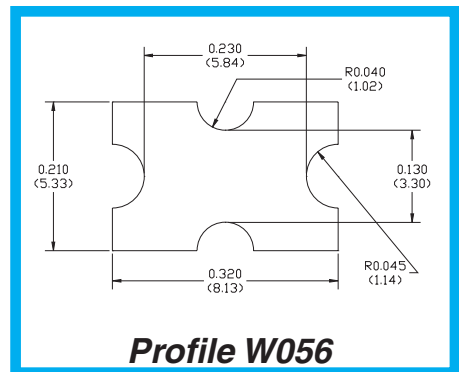
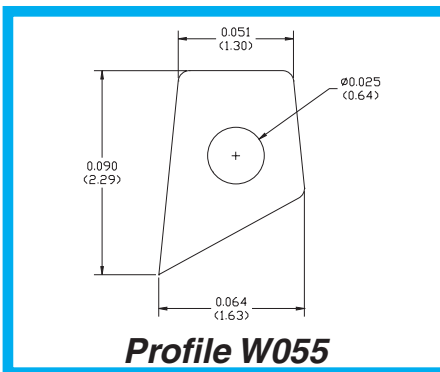
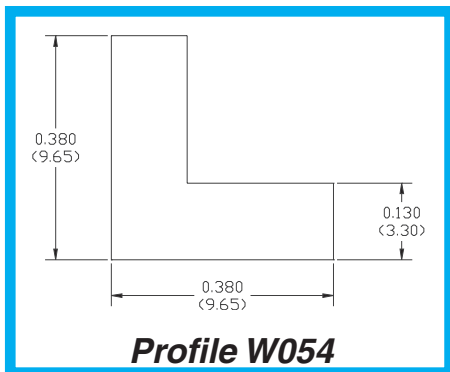
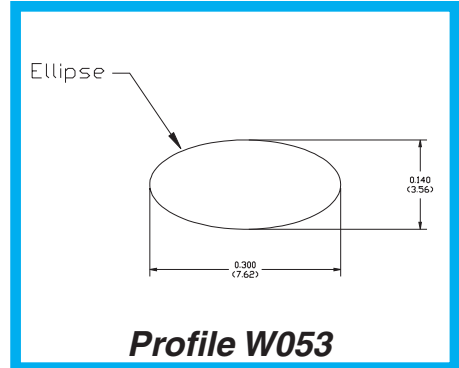
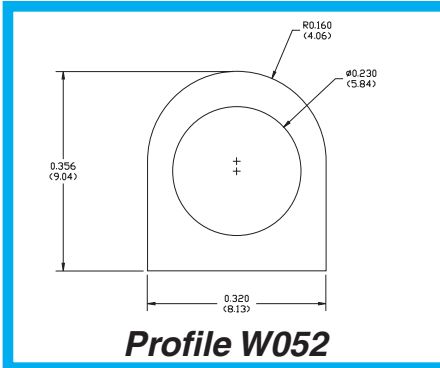
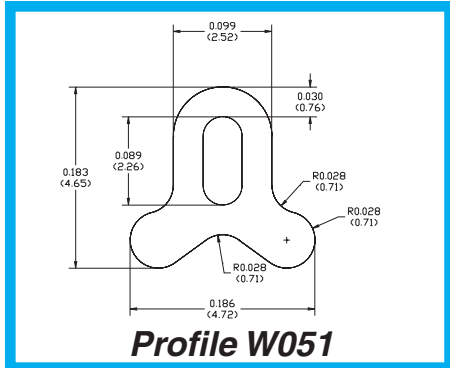


TechSeal Custom Extruded Profiles



PROFILES

**TechSeal Custom Extruded Profiles**



**Imagine your Custom Profile here ...  
 At TechSeal, we turn Imagination into reality!**

**PROFILES**

### Compression-Deflection

The compression force required to squeeze any type of elastomeric seal is a very important consideration of the overall mechanical design of any application. Solid (non-foam) elastomers are essentially incompressible materials; i.e., they cannot be squeezed into a smaller volume. When a solid elastomer is subject to a compressive load, it yields by deformation of the part as a whole. Because of this behavior, the actual deflection of a gasket under a compressive load depends upon the size and shape of the gasket as well as on its modulus and the magnitude of the load. The design of a seal should be such that its squeeze falls within the recommended percentages shown in Table 8 below.

### Recommended Deflection For Various TechSeal Extruded Elastomer Shapes

Cross-Section Geometry	Minimum Deflection	Nominal Deflection	Maximum Deflection
Solid "O"	10%	20%	30%
Solid "D"	10%	20%	30%
Rectangular	8%	15%	25%
Hollow "O", "D" and "P"	15%	30%	50%

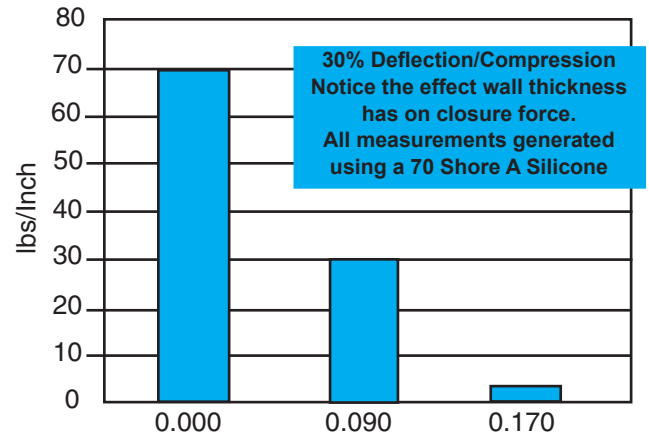
Note: For increased deflection requirements, TechSeal can provide special designed cross-sections/shapes.

**Table 8 - Recommended Deflection (Squeeze)**

It is recommended that the designer perform functional testing in the specific application to ensure proper compression force exists to adequately squeeze the elastomer.

There is an approximate relationship between the force required to deflect a pure elastomer a given amount, and the hardness of the elastomer. In general, the harder the elastomer, the greater the force required. Reduction in the elastomer hardness does have an impact on compressive force but the greatest impact on reduction of closure force can be accomplished by using an "LCF" (Low Closure Force Cross-Section), which is a hollow cross-sectional extruded profile. See Figure 6 and Table 9.

To date, the most common method for reducing closure force has been to reduce the Shore hardness of the elastomeric seal material or change to a foam-type material. The best method to achieve a dramatic reduction in closure-force is to change from a solid to a hollow cross-section profile without lowering durometer hardness. Controlling wall thickness is key to lowering the lbs/in of compressive force required. The chart (Fig. 6) illustrates the dramatic effect on closure force obtained by changing the cross-section of the seal element from solid to hollow.



**Figure 6 - Effect of geometry on closure force**

Solid-O .250 C/S			
Deflection (squeeze)		Durometer (Shore A)	
		40	70
10%	=	3.7 lb/in	11.9 lb/in
20%	=	10.3 lb/in	33.8 lb/in
30%	=	22.0 lb/in	71.8 lb/in
40%	=	43.5 lb/in	142.0 lb/in
50%	=	85.9 lb/in	280.0 lb/in

Hollow-O .250 C/S x .090 ID Low-Closure Profile			
Deflection (squeeze)		Durometer (Shore A)	
		40	70
10%	=	1.7 lb/in	5.6 lb/in
20%	=	3.8 lb/in	12.3 lb/in
30%	=	6.0 lb/in	19.7 lb/in
40%	=	8.9 lb/in	29.1 lb/in
50%	=	28.3 lb/in	92.4 lb/in

Hollow-O .250 C/S x .170 ID Ultra Low-Closure Profile			
Deflection (squeeze)		Durometer (Shore A)	
		40	70
10%	=	.2 lb/in	.7 lb/in
20%	=	.4 lb/in	1.3 lb/in
30%	=	.6 lb/in	1.8 lb/in
40%	=	.8 lb/in	2.7 lb/in
50%	=	1.3 lb/in	4.1 lb/in

**Table 9 - Sample deflection/closure force data**

Compressive load-deflection data for our most popular extruded elastomer shapes and materials are provided beginning on page 27.

For compression-deflection data on other TechSeal extruded profiles, contact your nearest Parker Seals Territory Sales Manager or our Applications Engineering Department.

COMPRESSION / DEFLECTION

## Finite Element Analysis (FEA)

As a premier manufacturer of sophisticated sealing solutions, TechSeal offers its customers the dramatic time and cost saving benefits of Finite Element Analysis (FEA). This advanced computer simulation technology is employed to predict the behavior characteristics of different cross-sectional seal designs, bypassing the development and trial-and-error testing of successive prototypes.

FEA will not only confirm that a proposed design will perform as expected, but allows the design to be optimized. Using complex FEA algorithms for elastomers, critical design information is obtained concerning:

- Deformation
- Load Deflection
- Volume
- Gland Fill %
- Stress Distribution
- Stability
- Friction Force
- Thermal Effect
- Material Selection
- Seal Life

At the Parker TechSeal Division, FEA capability is fully integrated into the design process for unusual or complicated seal configurations. The result is a technically superior solution achieved for our customers more rapidly and cost effectively than ever before allowing TechSeal and its customers to increase their speed to market.

The illustrations at right show the same profile design as a simple drawing (Fig. 7), as an actual FEA plot and as a developed Compression Deflection Curve predicted by FEA (Fig. 8).

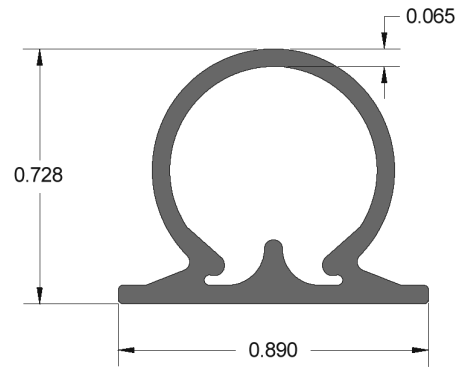
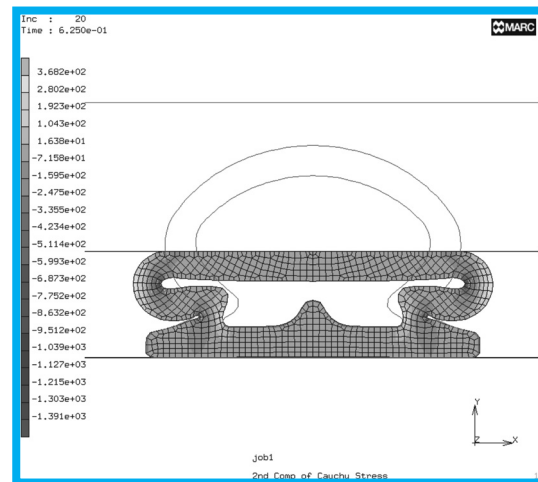


Figure 7 - Simple Drawing of Omega Profile



Typical FEA Generated Stress Plot

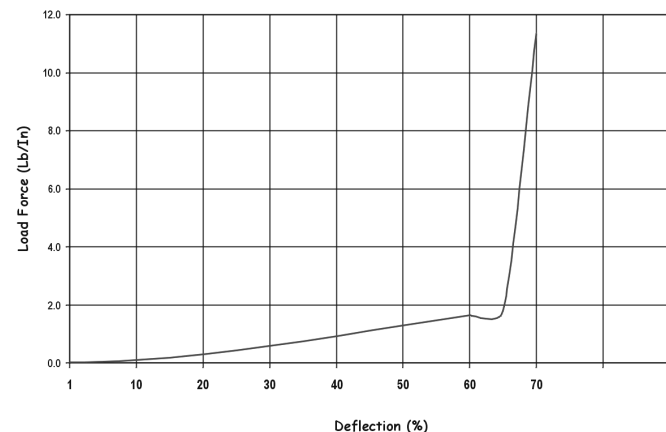
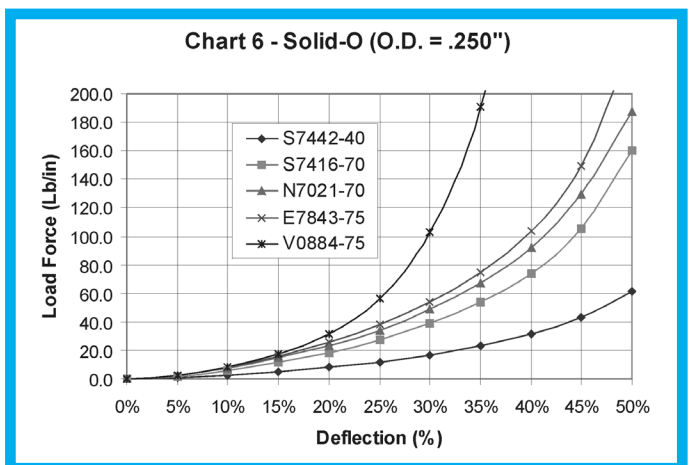
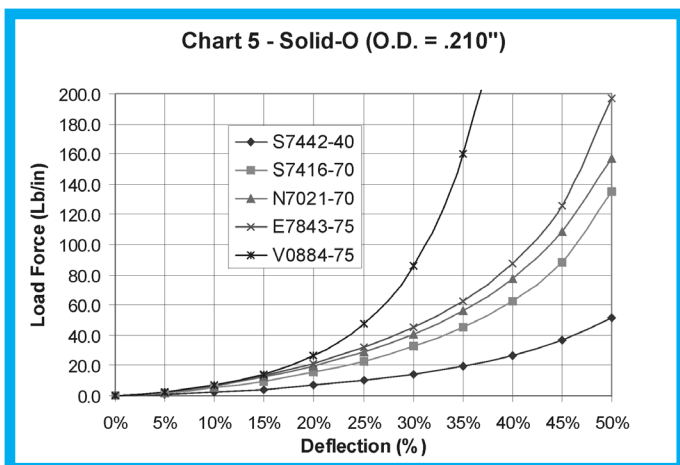
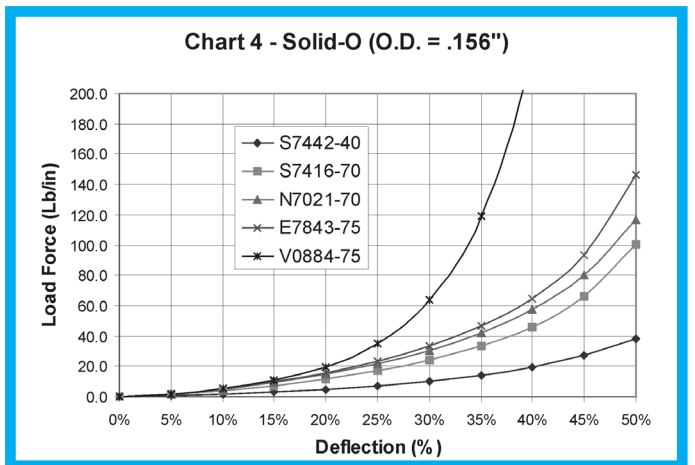
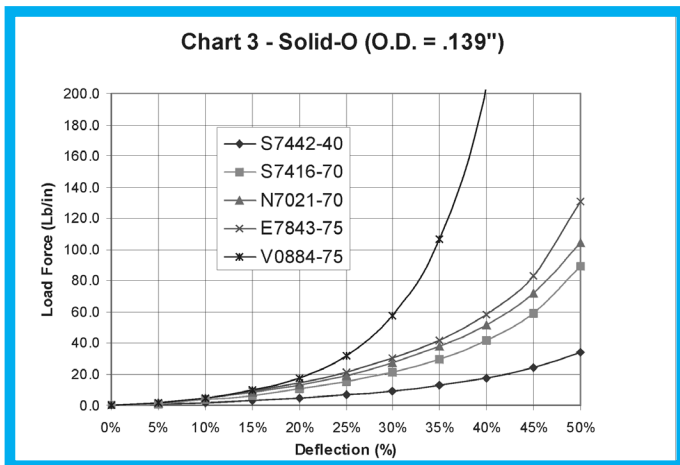
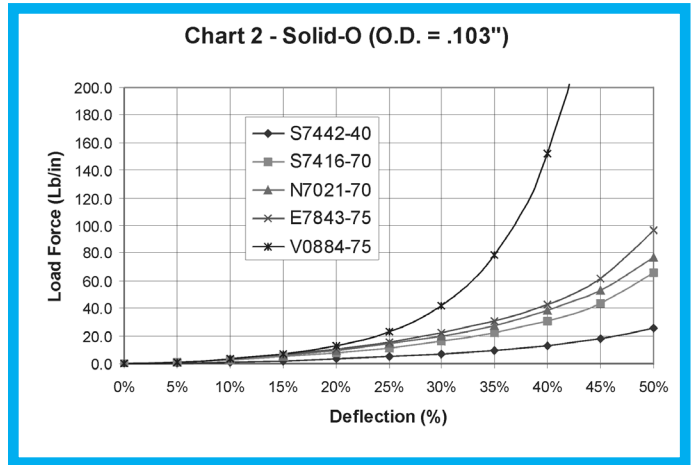
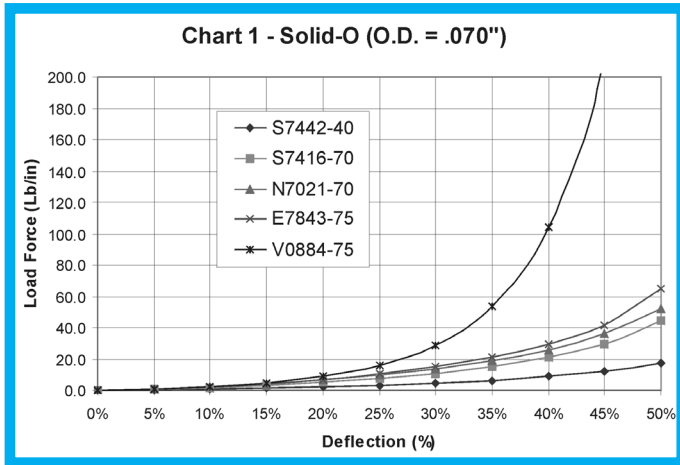


Figure 8 - FEA Generated Deflection Curve

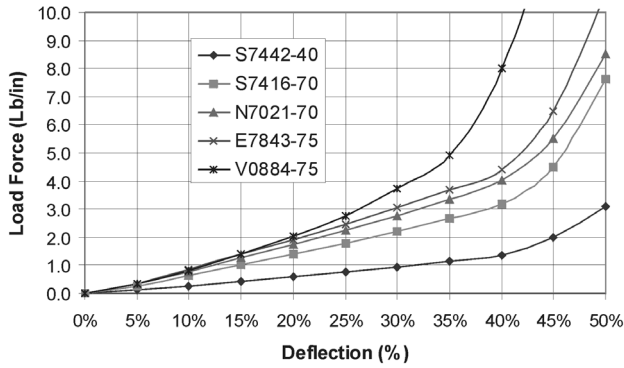
## Compression/Deflection Charts For TechSeal Profiles



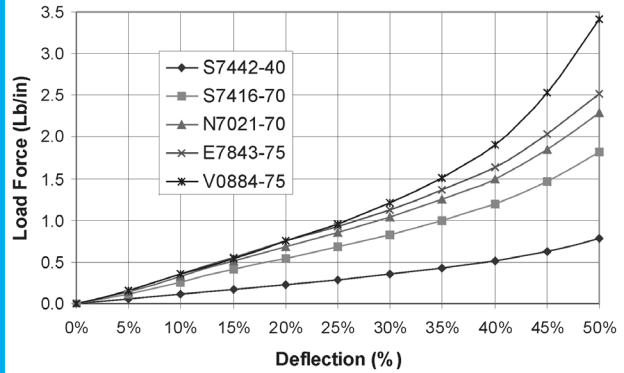
**COMPRESSION / DEFLECTION**

**Compression/Deflection Charts  
 For TechSeal Profiles**

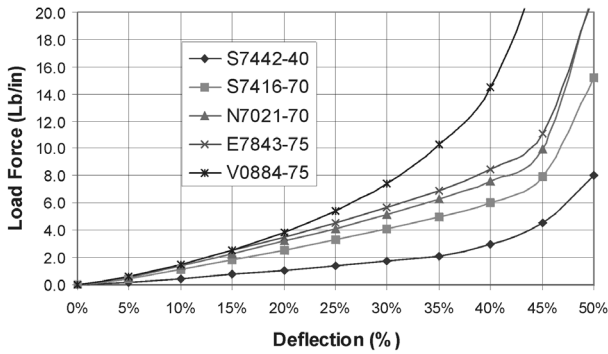
**Chart 7 - Hollow-O (O.D. = .070", I.D. = .030")**



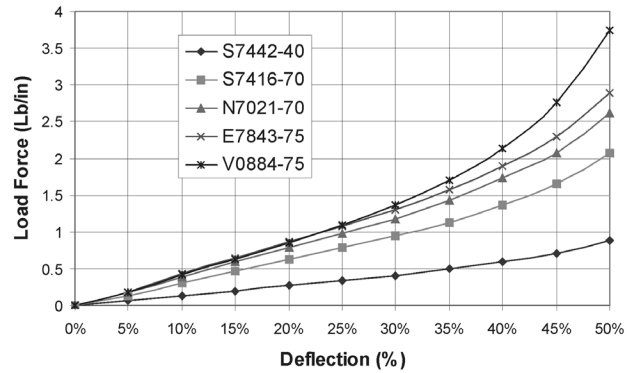
**Chart 8 - Hollow-O (O.D. = .070", I.D. = .040")**



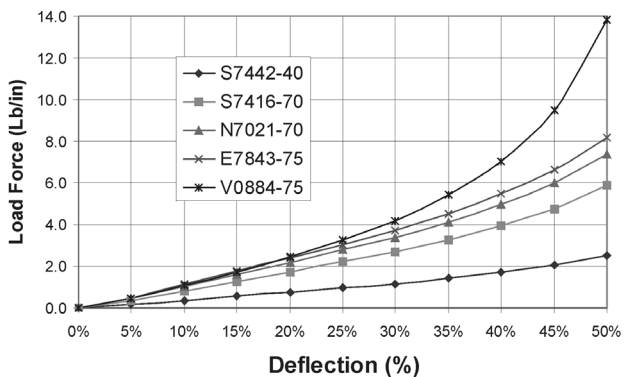
**Chart 9 - Hollow-O (O.D. = .103", I.D. = .040")**



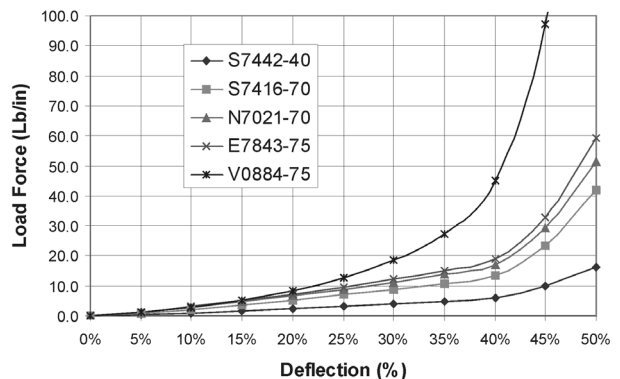
**Chart 10 - Hollow-O (O.D. = .103", I.D. = .062")**



**Chart 11 - Hollow-O (O.D. = .139", I.D. = .070")**

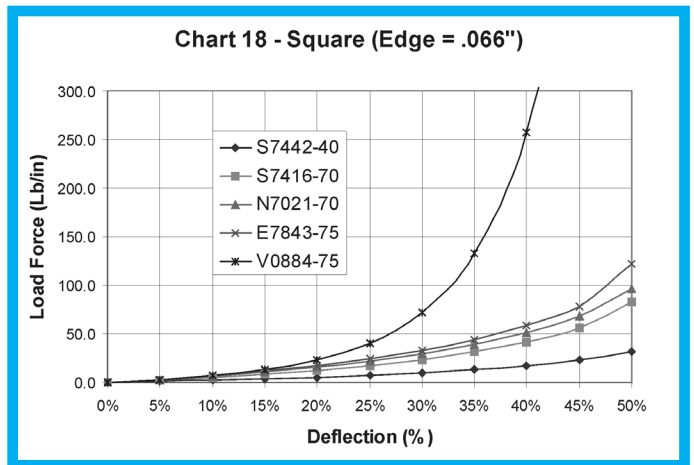
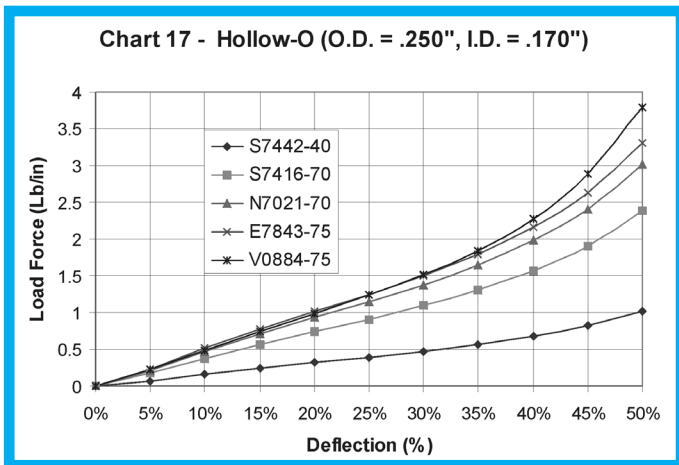
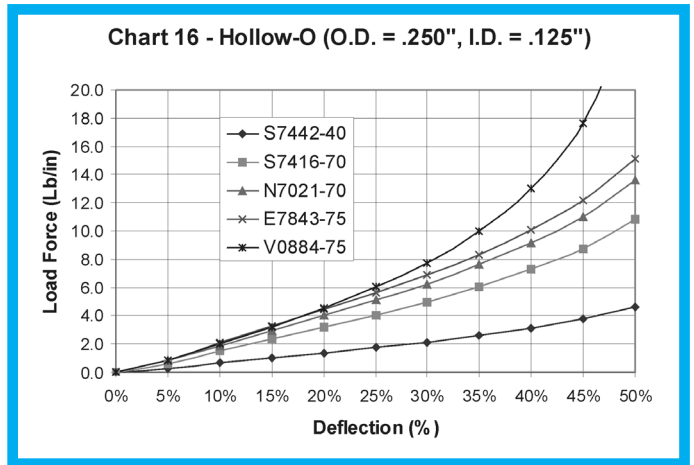
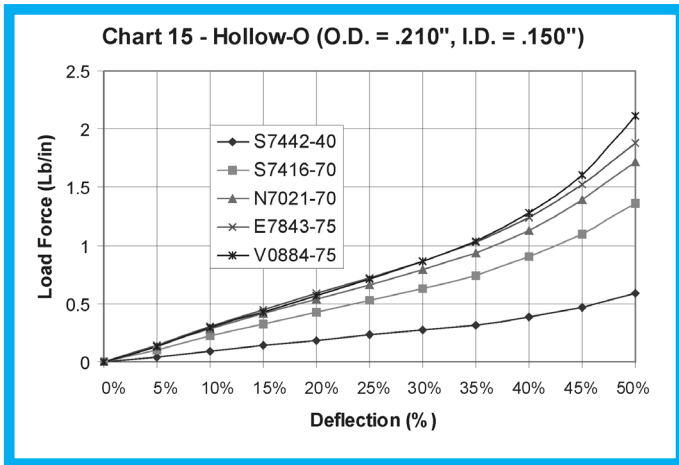
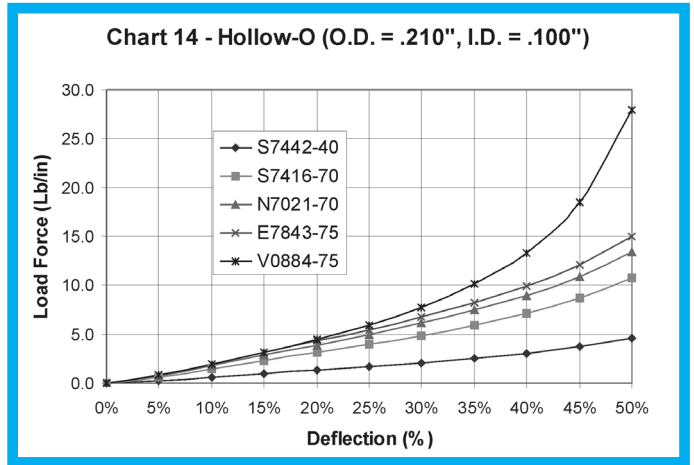
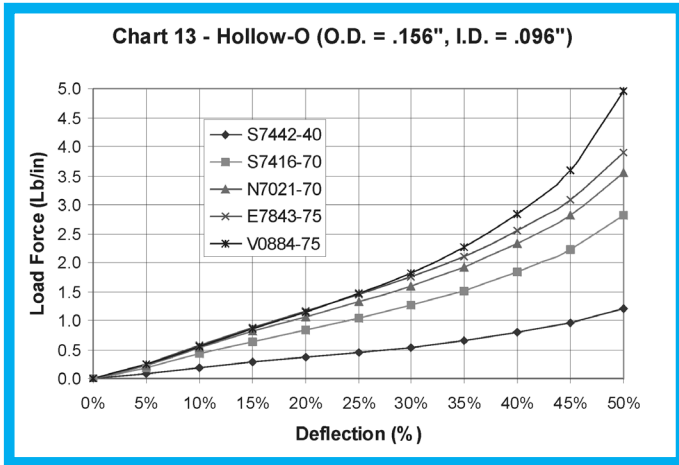


**Chart 12 - Hollow-O (O.D. = .156", I.D. = .050")**



COMPRESSION / DEFLECTION

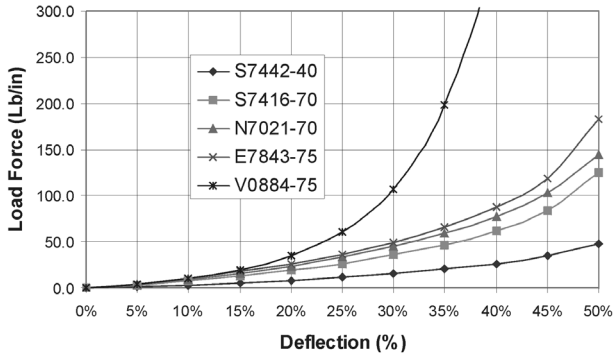
## Compression/Deflection Charts For TechSeal Profiles



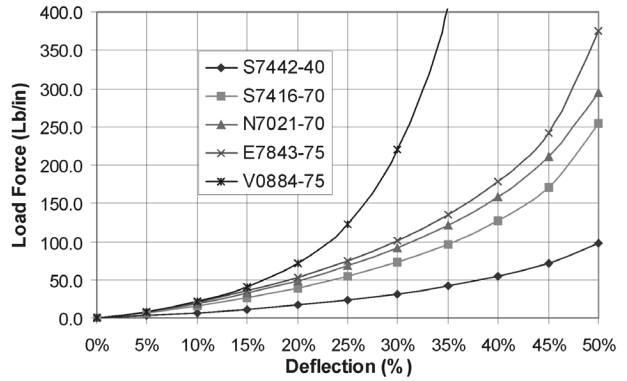
COMPRESSION / DEFLECTION

**Compression/Deflection Charts  
 For TechSeal Profiles**

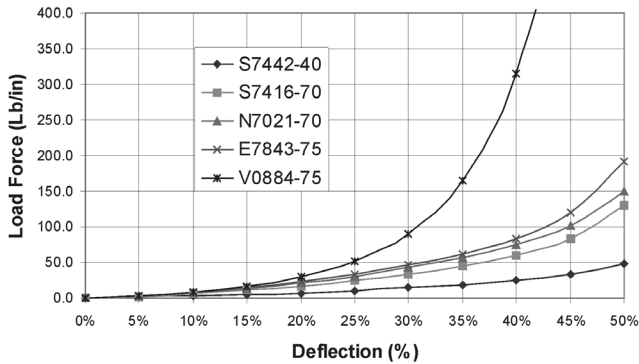
**Chart 19 - Square (Edge = .099")**



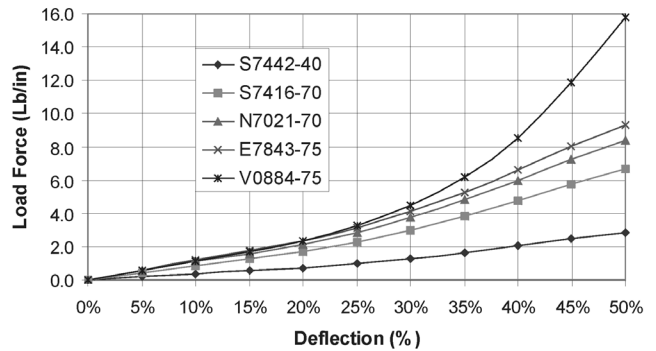
**Chart 20 - Square (Edge = .203")**



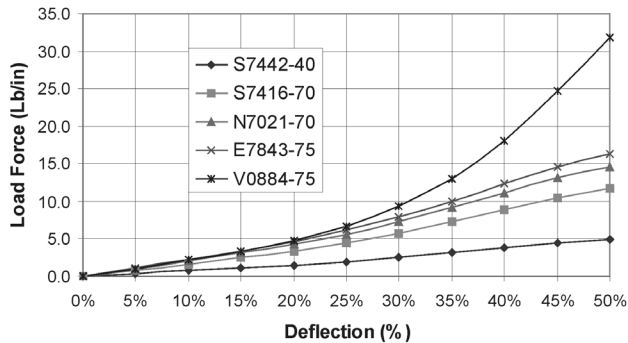
**Chart 21 - Solid-D (H = .156", W = .156", R = .078")**



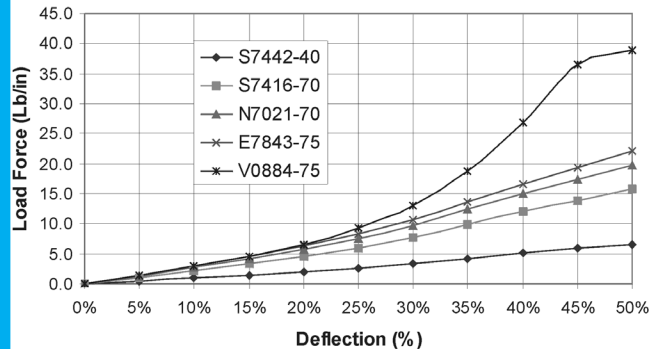
**Chart 22 - Hollow-D (A = .312", B = .156", C = .156", D = .045")**



**Chart 23 - Hollow-D (A = .488", B = .068", C = .244", D = .055")**



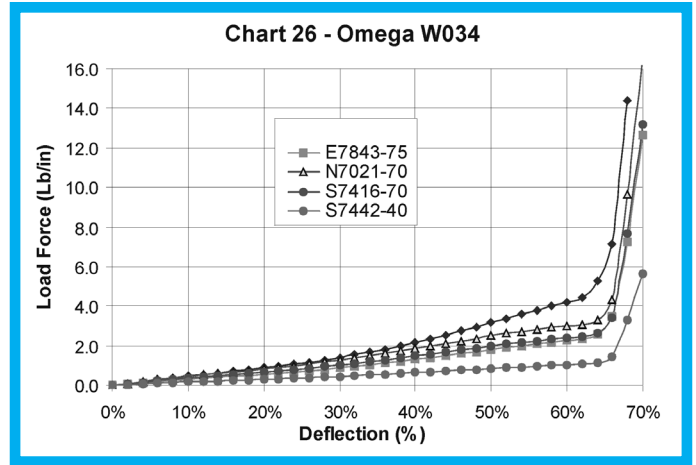
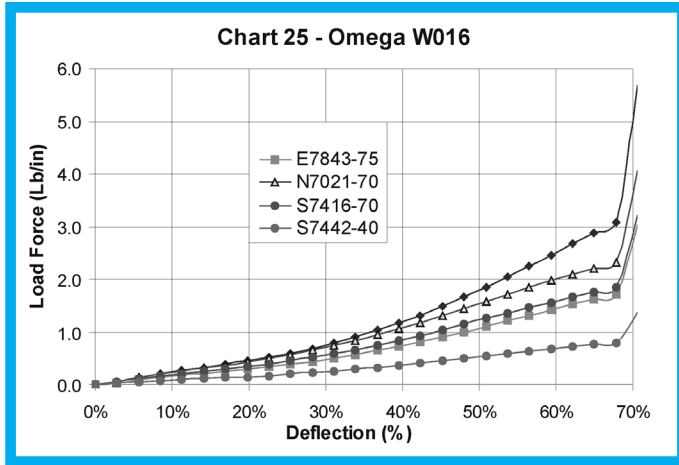
**Chart 24 - Hollow-D (A = .312", B = .156", C = .156", D = .062")**



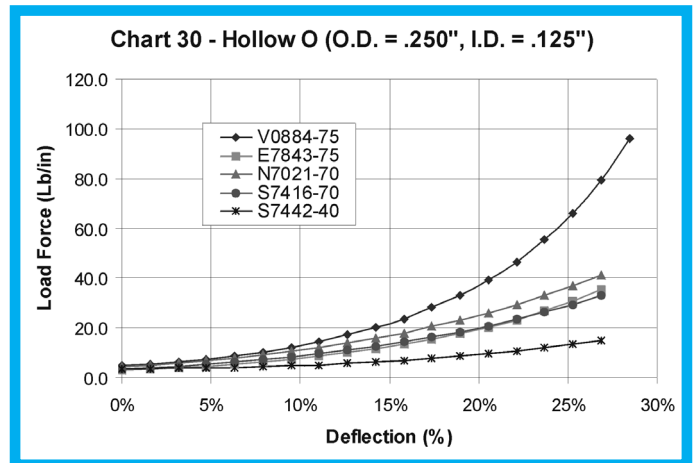
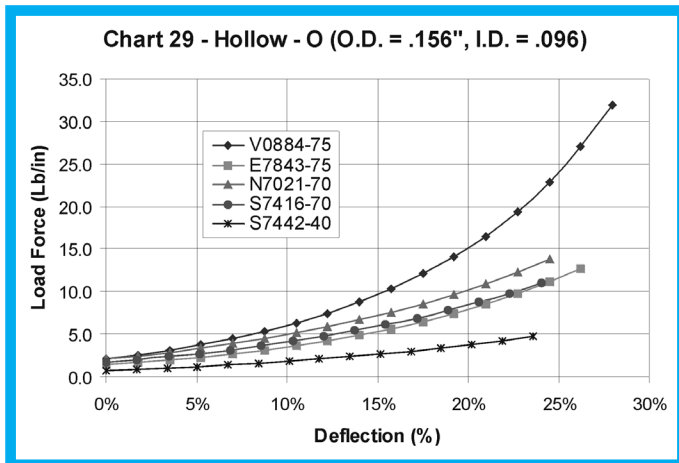
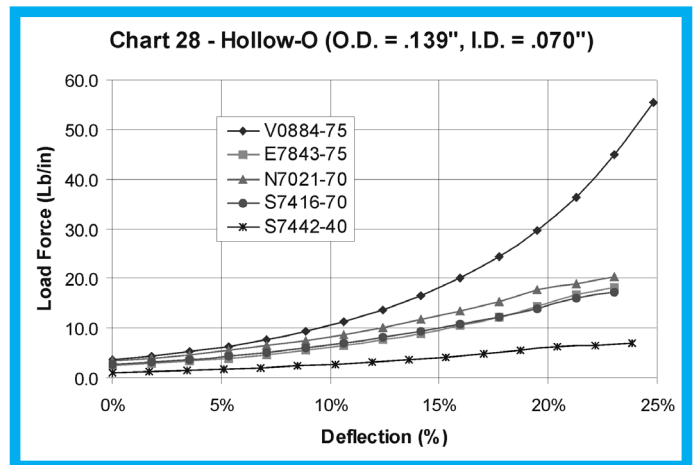
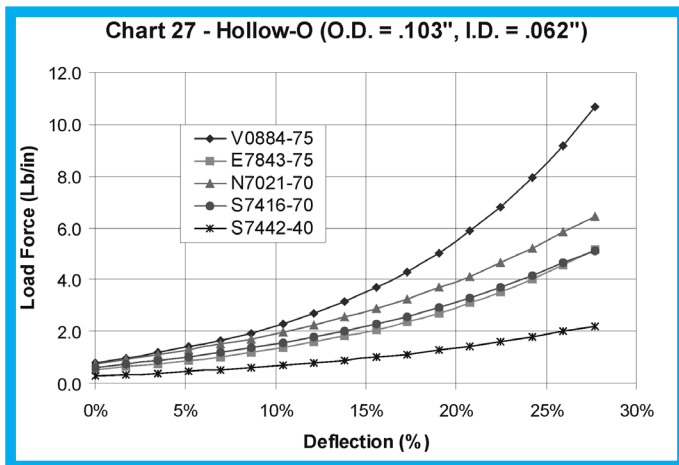
COMPRESSION / DEFLECTION



## Compression/Deflection Charts For TechSeal Profiles



### “Friction Fit Series”



COMPRESSION / DEFLECTION

## Physical and Chemical Characteristics of Elastomers

It is absolutely necessary to consider the important physical and chemical properties of seal elastomer formulations. This is needed to provide a clearer picture of how they fit together and enter into the selection process of the optimal seal compound. In this manual the term fluid is used to denote the substance contacting the seal. It may be a liquid, a gas, a vapor, or a mixture. It shall apply to powders and solids as well.

Seal failures typically are due to use of an improper gland design, polymer selection or, a combination of the two. There are significant differences between the physical properties of most synthetic elastomer polymer families, as well as differences between the properties of compound formulations within the same polymer family.

The physical and chemical properties a material typically exhibits will establish the best candidate for use in a particular application. The physical properties most commonly used when establishing the best synthetic elastomer formula candidate are as follows:

### Resistance to Fluid Medium

#### Hardness

#### Toughness or durability (composite of six material characteristics)

##### Tensile Strength

##### Elongation

##### Compressive Force

##### Modulus

##### Tear Resistance

##### Abrasion Resistance

### Volume Change

### Compression Set

### Thermal Effects

#### Resilience

#### Deterioration

#### Corrosion

#### Permeability

#### Coefficient of Friction

#### Coefficient of Thermal Expansion

#### Compression Stress Relaxation

**Resistance to Fluid** - The chemical effect of the fluid on the seal is of primary importance. The fluid must not alter the operational characteristics or reduce the life expectancy of the seal significantly, meaning that excessive deterioration of the seal must be avoided.

A significant amount of volume shrinkage usually results in a premature leakage of any seal. Conversely, a compound that swells excessively in a fluid, or develops a large increase or decrease in hardness, tensile strength, or elongation can continue to serve well for a long time as a static seal.

**Hardness** - In the seal industry, the Type A durometer, manufactured by the Shore Instrument Company, is the standard instrument used to measure the hardness of most rubber compounds. The Type D durometer is recommended when the Type A reading is over 90. For specimens that are too thin or that have too small of an area to attain accurate durometer readings, it is recommended that standard size test specimens be used from the same material lot in order to establish the hardness properties of the material being evaluated.

The durometer has a calibrated spring which forces an indenter point into a test specimen against the resistance of the rubber material. There is an indicating scale on which the hardness is read directly. It is calibrated to read if there is no penetration, as on a flat glass or steel surface.

Softer materials, meaning those with lower hardness readings, will flow more easily into the microfine grooves of the mating part. This is significantly important in low pressure seals because they are not activated by fluid pressure. Conversely, the harder materials offer greater resistance to flow, and therefore are less likely to flow into the clearance gap beyond the groove.

In dynamic applications the hardness of a material has a major effect on friction. A harder material will typically have a lower coefficient of friction than a softer material, however the actual running and breakout friction values are higher because the load required to squeeze the seal is greater.

For most applications compounds exhibiting nominal Type A durometer readings of 70 or 80 offer the best compromise. This is particularly true when dynamic forces or mechanics are involved in an application. Materials with durometer hardnesses of 90 or higher often allow a small amount of fluid to pass through with each cycle, while soft materials may have a tendency to abrade, wear and extrude.

Durometer hardness is typically established with a tolerance of  $\pm 5$  points, with the nominal or average hardness rounded off to the nearest 5 in increments of 5 or 10, such as **60** durometer, **75** durometer, etc. - not as **62** durometer or **71** durometer.

This is due to batch-to-batch variability of the formulation and variances encountered when using the durometer gages.

**Toughness** - This is a general term used to describe the combined effects of six different physical forces, rather than chemical action. The six forces are: tensile strength, elongation, compression force, modulus, tear resistance and abrasion resistance. Toughness is used as a relative term, and the six contributing factors are noted defined below.

**Tensile Strength** - is the force per unit area, measured in pounds per square inch, obtained by stretching a standard test specimen of rubber until it ruptures. It is a production control measurement used to insure uniformity of a compound, and can also be used to establish the deterioration of a material formulation after it has been in contact with a fluid for a long period of time. This information is used as a tool to predict the life span of a given material in a specific environment. Tensile strength is not a proper indication of resistance to extrusion, and is typically not used in design calculations. In dynamic applications a minimum of 1,000 psi is normally required to assure adequate strength characteristics.

**Elongation** is defined as a percent increase in length over the initial length of a seal. For establishing typical physical properties, it is usually expressed as ultimate elongation, which is the percent value attained when the test specimen breaks. This property primarily establishes the stretch that can be tolerated during the installation of a seal.

The smaller the seal, or the cross section of the seal, the more important the elongation properties. This value is also an indicator of the material and part dimensions combined effective ability to recover after installation stretch, peak overload, or localized source in one small area of a seal when considered with tensile strength. An adverse change in the elongation of a material after exposure to a fluid is a definite sign of degradation of the material. Elongation, like tensile strength, is used in the industry as a check on production batches of material.

It is recommended that standard test specimens be utilized when establishing a material's elongation properties in order to eliminate part specific variations that can occur due to geometric differences. Part specific profiles, however, can be established, but should not be used as specification limits.

**Compressive Force** is the force required to compress a seal cross section the proper amount to maintain an effective seal. This is especially important for applications that require low compressive loads.

Factors that have an effect on the amount of compressive force include the hardness of the material (durometer), cross section geometry (solid versus hollow), wall thickness if hollow, and amount of compression. Holding all factors constant, the compressive force will vary if the seals are made from two different compound formulations, even if material hardness is similar. The anticipated load for a given installation, then, is not fixed, but is a range of values. Increasing the temperature can soften elastomeric materials, yet the compressive force decreases very little except for the hardest compounds.

**Modulus** - as used in rubber terminology, modulus refers to the amount of stress at a predetermined elongation, usually 100%. It is expressed in pounds per square inch. The higher the modulus of a compound, the more apt it is to recover from peak overload or localized force and the better its resistance to extrusion. Modulus normally increases as the material durometer increases and is probably the best indicator of the toughness of a compound, all other factors being equal. It is also used as a production control because it has a tendency to be much more consistent than tensile strength or elongation.

Modulus can also be used as a tool to predict seal life when combined with testing in heat, fluids, or a combination.

It is recommended that standard test specimens be utilized when establishing a material's modulus properties in order to eliminate part specific variations that can occur due to geometric differences. Part specific profiles, however, can be established, but should not be used as specification limits.

**Tear Resistance** - Tear strength is relatively low for most compounds. If it is below 100 lbs./in. there is an increased danger of nicking or cutting the seal during the assembly process, especially if the seal must pass over sharp edges or burrs. Seal compounds with poor tear resistance will fail quickly under further flexing or stress, once a crack is started.

Inferior tear strength of a compound is also indicative of poor abrasion resistance, which may lead to early failure of a material when used as a dynamic seal. Typically this does not need to be considered in static sealing applications.

**Abrasion Resistance** - Abrasion resistance is a general term used to describe the wear resistance of a compound. This terminology concerns rubbing or scraping of the seal's surface and therefore is important in dynamic sealing applications.

Only certain elastomers are recommended for use where moving parts actually contact the seal. Hollow cross sections typically are not used in dynamic applications, with the exception of container seals that are exposed to opening and closing of the two mating components, and can be defined as static seals after the assembly is closed.

Higher durometer compounds, up to 85 durometer, are typically more resistant to abrasion than softer compounds.

**Volume Change** - Volume change is measured as a percent (%) and is the increase or decrease in elastomer volume after it has been in contact with a fluid when compared to the original seal sample volume.

**Swell**, or an increase in volume, is almost always accompanied by a decrease in hardness. Excessive swelling will result in a marked softening of the rubber, which will lead to reduced abrasion and tear resistance, and may permit extrusion of the seal into adjacent gap areas under high pressure. For static applications volume swell up to 50% may be tolerated, providing that provisions are made to the gland design to prevent stress to the assembly. For dynamic applications, swell of 15 to 20% is a typical maximum unless provisions are made to the gland design.

Material swell can supplement a seal's effectiveness under certain circumstances. Swell may offset compression set. An example, is as a seal relaxes 15% and swells 20%, the relaxation (compression set) tends to be cancelled by the swell.

Absorbed fluid may have a similar effect on a compound as does the addition of plasticizers, providing additional flexibility at the low end temperature of its operation range. These effects should not be relied upon when selecting a compound for an application, however they can contribute to seal performance.

The amount of swell that a material exhibits after long term fluid exposure – stabilized volume – is seldom reported because it may take a month or more at elevated temperatures to attain. On occasion the usual 70 hour immersion test will indicate a swelling effect, whereas a long term test shows shrinkage. Therefore swell characteristics indicated by short term testing may only be an interim condition.

**Shrinkage**, or a decrease in volume, is almost always accompanied by an increase in hardness. As swell compensates for compression set, shrinkage intensifies compression set, causing the seal to pull away from the sealing surfaces and creating a leak path. Therefore, shrinkage is far more critical than swell. More than 3 or 4% shrinkage can be serious for moving seals. The fluids present may extract plasticizers from the material that causes the seal to shrink when the fluid is temporarily removed. This type of shrinkage may or may not be serious, depending on magnitude, gland design and degree of leakage tolerable before the seal re-swells. Even if the seal re-swells there is the possibility that it will not properly re-seat itself. If any shrinkage is a possibility in an application, it must be considered thoroughly and carefully.

**Compression Set** - Compression set is generally determined in air, and is reported as the percent deflection by which an elastomer formulation fails to recover to its original size, after a fixed time under a specified squeeze and temperature. As an example, 0% would indicate that no relaxation has occurred, while a value of 100% would indicate that total relaxation has occurred.

Even though it is desirable to have a low compression set, this condition may not be critical from a design standpoint because of actual service variables. A good balance of all physical properties is typically necessary to optimize sealing performance.

As an example, a seal can continue to function after taking a compression set of 100% providing the temperature and system pressure remain constant and no motion or force causes the seal line of contact to break. As previously mentioned, swelling caused by service fluid exposure may compensate for compression set.

The condition to be feared the most is a combined effect of compression set and shrinkage. This will lead to seal failure unless exceptionally high squeeze is used in the application.

If the seal profile being utilized in an application is hollow, increasing the outside diameter of the seal can reduce compression set. This can also be combined with an increase in the inside diameter of the seal to avoid creating an overflow condition with the seal gland. By increasing the diameter(s), an increase in squeeze is being created which can offset the actual compression set characteristics noted for the application. The actual percent compression set realized may be comparable, however the true distance the seal is being compressed is larger, effectively increasing the displacement distance and increasing (possibly) the deflection force required.

**Thermal Effects** - All rubber is subject to deterioration at high temperature. The volume change and compression set properties are both greatly influenced by heat. Hardness is influenced in several ways. An increase in temperature can soften the material, which is a physical change, and this condition will reverse when the temperature goes back down. This effect must be considered in high pressure applications, because a compound that resists extrusion at room temperature may begin to flow through the clearance gap as the temperature rises.

Over time with exposure to high temperatures chemical changes begin to occur to the material. These typically cause an increase in hardness, along with volume and compression set changes as previously mentioned. Changes in tensile and modulus properties can also occur. Since these are chemical changes, they are not reversible.

Changes caused due to exposure to low temperatures are usually physical and reversible. An elastomer will almost totally regain its original physical properties when warmed.

Several tests are available to define the low temperature characteristics of a material, the most common of which is the military modified version of TR-10 or Temperature Retraction.

The TR-10 results are easily reproducible. For this reason this type of testing is used to assure low temperature performance and on occasion as a production consistency check. Most compounds will provide effective sealing at 15°F (8°C) below their TR-10 temperature values.

If low pressures are expected in an application at low temperatures, hardness should be considered along with the low temperature properties of the material. As temperature decreases, hardness increases.

Low pressures require a soft material that can be deformed easily into or against the mating surfaces. Hollow profiles using harder durometer compounds can also generate this same type of effect, with the addition of the higher tensile and modulus properties these harder materials typically exhibit.

Hardness is only one of several criteria to consider when low temperature sealing performance is involved. Flexibility, resilience, compression set and brittleness can serve as more basic criteria for sealing at low temperature.

Durometer measurements alone are not reliable indicators of low temperature sealing performance. The swelling or shrinkage effect of the fluid being sealed must also be taken into account. If the seal swells, it is absorbing fluids, which may act in much the same way as a low temperature plasticizer: it will allow the seal to be more flexible at lower temperatures than it would without the fluid exposure.

If the seal shrinks, something is being extracted from the compound. This is typically the plasticizer provided for low temperature flexibility. As a result, the seal may lose some of its ability to flex at low temperatures.

Crystallization, or the re-orientation of molecular segments causing a change of properties in the compound, is one side effect of low temperature exposure that must be considered, especially in applications where dynamics are involved. When this happens, the seal has no resiliency and becomes rigid.

This condition usually shows up as a flat spot on the seal surface, and it can be confused with compression set. When the seal is warmed, the flatness will gradually disappear and the seal will regain its resilience. It may take several months for a seal to initially crystallize at low or moderate temperatures, however on succeeding exposures crystallization sets in much more rapidly. The end result of crystallization is seal leakage.

**Resilience** - Resilience is the ability of a material to return quickly to its original shape after temporary deflection. This is primarily an inherent property of the elastomer. It can be improved, somewhat, by compounding. More importantly, poor compounding techniques can destroy it. Sealing performance depends on good resiliency to optimize

performance, such as hollow environmental cabinet seals or two-part hinged containers. This is established by choosing the proper combination of elastomer and geometry for each sealing application.

**Deterioration** - This term typically refers to a chemical change in the elastomer that results in a permanent loss of properties. It is not to be confused with reversible or temporary property losses. Both permanent and temporary property losses can be accompanied by swell. The temporary condition is due to physical permeation of the fluid without chemical alteration.

**Corrosion** - Corrosion is the result of chemical action of a fluid and/or the compound on the metal surface of the seal gland. Fluid corrosion of the metal gland will cause a change of finish that can vitally effect the seal. When rubber seal were first being used, there were many instances where the compound did adversely effect the metal gland causing pitting on the surface. Specific elastomer compounding ingredients, like uncombined sulfur, were found to cause the problem.

Current day compounding and ingredient technologies have made reports of corrosion rare. However, as new compounding ingredient technology is introduced continuous attention to corrosive effects is necessary.

**Permeability** - Permeability is the tendency of a gas to pass or diffuse through the elastomer. This should not be confused with leakage, which is the tendency of a fluid to go around a seal. Permeability is of prime importance in vacuum service and a few pneumatic applications involving extended storage.

Three basic rules apply: Permeability increases as temperatures rise. Different gasses have different permeability rates. The more a seal is compressed, the greater its resistance to permeability.

Most materials used in vacuum applications are typically exposed to additional (post) cure to drive off any residual water or volatiles in the compound. This reduces the possibility of outgassing, which in turn can cause serious degradation of the system being sealed.

**Coefficient of Friction** - Coefficient of friction of a moving rubber seal relates to hardness, lubrication and the surface characteristics of the surrounding materials. Typically, breakout friction is many times greater than running friction, but this can vary with the hardness of the material. Usually an increase in compound hardness will increase breakout friction while a decrease in hardness lowers breakout friction.

**Coefficient of Thermal Expansion** - Coefficient of linear expansion is the ratio of the change in length per °F to the length at 0°F. The coefficient of volumetric expansion for a solid is roughly three times the linear coefficient. Elastomer typically

exhibit a coefficient of expansion ten times that of steel. This characteristic can be a critical factor at high temperatures if the gland is nearly filled with the seal or at low temperatures if the squeeze is minimal.

Reactions can take place that can cause a seal to generate relatively high forces against the sides of a seal groove. These forces are generated by thermal expansion of the rubber and/or the swelling effect of a fluid.

If the seal is completely confined and the gland is 100% filled, the dominating force is the force of thermal expansion. Force applied by the seal due to the effects of fluid swell is very minor if the gland volume exceeds the seal volume by 5 to 10%.

It is recommended that in no case should the gland fill percentage exceed 95%.

**Compression Stress Relaxation** - Throughout the rubber industry compression set testing has been established as the primary methodology used to establish a seal material's ability to seal over time. Another method that can be utilized is compression set relaxation or CSR. This measures the change in resistant force (decrease) over time that a material exhibits when exposed to a constant compressive force (typically 25%).

This methodology provides a measure of initial force displacement and retention over time, which can be used as a tool to predict a material's long term sealing ability.

## Standard Test Procedures

There are standard ASTM procedures for conducting tests on rubber materials. These procedures must be followed carefully and properly if consistent test results are to be generated.

## Test Specimens

ASTM test procedures include descriptions of the standard specimen sizes needed for each test.

Part geometry can play a very large role in establishing physical properties variation. As an example, in fluid immersion tests smaller cross section seals can swell more than larger cross section seals.

Using direct property readings from hollow cross section seals is not recommended. While it is possible to establish a performance envelope that is part specific, tolerance stack-ups, normal batch-to-batch variation and cross sectional geometry can provide a wide fluctuation in test results. This effect can be realized even when comparing the part-specific properties of two different profiles of the same configuration (i.e.: hollow round) that are produced from the same lot of material. It is recommended that if test data is required and/or if samples of the cured material are required for user evaluation, that standard ASTM test specimens be utilized.

## Environmental Changes

High humidity in air will reduce the tensile properties of some materials. Changes to a fluid can occur in service due to the effect of heat and/or contaminants that can cause a rubber material to react differently than when exposed to new fluid. For this reason tests are sometimes conducted in used fluid, to essentially duplicate the environment the seal will be exposed to in actual service.

## Aging

Deterioration over time, or aging, relates to the nature of the rubber molecule itself: long chain-like structures (polymers) composed of many smaller molecules (monomers) joined together. The points where the individual molecules are joined together are called bond sites. Bond sites and other areas may be susceptible to chemical reaction, of which three basic types are associated with aging:

1. *Scission* - The molecular bonds are cut, dividing the chains into smaller fragments. Ozone, ultraviolet light and radiation exposure are typical causes.
2. *Cross Linking* - An oxidation process whereby additional intermolecular bonds are formed, usually caused by heat and oxygen exposure.
3. *Modification of Side Groups* - A change in the complex, weaker fringe areas of the molecular construction due to chemical reaction. Moisture is an example of a cause contributor.

All mechanisms by which rubber deteriorates are due to the environment and exposure. Therefore it is the environment, not age, that impacts seal life, in both storage and actual service.

## Storage

Storage, or shelf life, can vary with the resistance of each synthetic elastomer to normal storage conditions as well as the method of packaging. Consult the TechSeal Division for specific information on storage/shelf life of individual elastomer materials. The ideal elastomer product storage environment would provide:

1. *Ambient temperatures not exceeding 120°F (49°C).*
2. *Exclusion of air (oxygen).*
3. *Exclusion of contamination.*
4. *Exclusion of light (especially sunlight).*
5. *Exclusion of ozone .*
6. *Exclusion of radiation.*
7. *Exclusion of moisture.*

## Physical Property Definitions & Material Selection

### Durometer

Hardness, measured in points typically with a Shore A durometer. Determine the best durometer for the application and round off to the nearest 5 (50, 55, 60, etc.). A standard  $\pm 5$  point tolerance is applied to permit normal variation in polymer lots and durometer reading methodologies.

### Tensile Strength

Determine the minimum tensile strength (measured in psi) for the application. Always take into consideration the typical strength of the elastomer that is most likely to be used. Once established, multiply this minimum value by 1.20 (for example:  $1,000 \times 1.20 = 1,200$ ). This now becomes the minimum tensile strength for the application, and provides a buffer for normal compound production batch variation.

### Elongation

Evaluate and establish the maximum amount of stretch (measured in %) a seal will be exposed to for assembly in the application. Multiply this value by 1.25 to allow a safety factor and to compensate for normal material variation.

### Modulus

Select a minimum modulus (measured as tensile strength at a specific amount of elongation, typically 100%) that will assure good extrusion resistance, facilitate the assembly process, and provide good recovery from peak loads.

If the spliced profile is hollow, the amount of force required to stretch the seal will decrease as the internal cross-sectional area increases, providing the outside dimension remains constant. In other words, as the wall thickness (radial) of the profile decreases, the force required to stretch the seal also decreases.

### Specific Gravity

A value for specific gravity is typically not established as a criteria for most seal design applications. Instead, the specific gravity for the material selected at the end of the evaluation process can be used for material quality control purposes. If a tolerance for this value is necessary, typically a range of  $\pm .03$  is applied.

### Aged Physical Properties

It is absolutely necessary to determine the resistance of the seal in the application when exposed to the actual service environment. The initial material performance characteristics can be established by measuring the change in volume and physical properties of the candidate material, using test specimens, after exposure to various conditions for specific times and temperatures (i.e., 70 hours @ 212°F (100°C)).

Recommended times, temperatures and test fluids can be found in ASTM Method D471. It is suggested that the actual service fluid be used whenever possible. Bear in mind that fluid variation can account for differences in test results.

### Hardness Change

Reported as point change, this value is usually controlled to avoid excessive softening (causing extrusion into the clearance gap or a loss of seal resiliency) or hardening (causing cracking, lack of resiliency, increase in load deflection force or leakage).

### Tensile Strength Change

Reported as % of original tensile strength, this value is usually established with a reasonable maximum value to insure excessive deterioration and seal failure does not take place. Each fluid and material combination has its own performance characteristics and resultant limitations.

### Elongation Change

Reported as % of original elongation, the guidelines are similar to that of tensile change.

Every designer should establish realistic limits and tolerances based upon past experience in the same or similar application. Excessive hardening, gain in tensile strength and loss of elongation after fluid exposure (immersion) are indications of over aging. Excessive softening, loss of tensile strength and gain of elongation can be indications of reversion (return of the material to its uncured state).

### Volume Change

Reported as the % increase or decrease in the volume of the test specimen. When the test fluid is air, weight change rather than volume change is typically used.

Determine the maximum amount of acceptable swell for the application, which is usually 50% for static sealing applications.

Determine the maximum amount of acceptable shrinkage for the application, which is usually 3 - 4% for static applications. Take into consideration dry-out cycles that may be encountered in service, and include a dry-out test after the fluid immersion test to establish the material performance profile. Bear in mind that shrinkage is a prime cause of seal failure.

Establish the minimum and maximum acceptable volume change value limits for the desired material in each fluid the compound will be exposed to in the application.

Note that different size test specimens will exhibit different volume swell characteristics over time. This difference is very noticeable after only 70 hours of test time, which is one of the most popular evaluation durations for accelerated testing. Solid profiles behave differently than hollow profiles.







The items described in this document are hereby offered for sale at prices to be established by Parker Hannifin Corporation, its subsidiaries and its authorized distributors. This offer and its acceptance by any customer ("Buyer") shall be governed by all of the following Terms and Conditions. Buyer's order for any item described in its document, when communicated to Parker Hannifin Corporation, its subsidiary or an authorized distributor ("Seller") verbally or in writing, shall constitute acceptance of this offer.

**1. Terms and Conditions of Sale:** All descriptions, quotations, proposals, offers, acknowledgments, acceptances and sales of Seller's products are subject to and shall be governed exclusively by the terms and conditions stated herein. Buyer's acceptance of any offer to sell is limited to these terms and conditions. Any terms or conditions in addition to, or inconsistent with those stated herein, proposed by Buyer in any acceptance of an offer by Seller, are hereby objected to. No such additional, different or inconsistent terms and conditions shall become part of the contract between Buyer and Seller unless expressly accepted in writing by Seller. Seller's acceptance of any offer to purchase by Buyer is expressly conditional upon Buyer's acceptance to all the terms and conditions stated herein, including any terms in addition to, or inconsistent with those contained in Buyer's offer. Acceptance of Seller's products shall in all events constitute such assent.

**2. Payment:** Payment shall be made by Buyer net 30 days from the day of delivery of the items purchased hereunder. Any claims by Buyer for omissions or shortages in a shipment shall be waived unless Seller receives notice thereof within 30 days after Buyer's receipt of the shipment.

**3. Delivery:** unless otherwise provided on this face hereof, delivery shall be made F.O.B. Seller's plant. Regardless of the method of delivery however, risk of loss shall pass to Buyer upon Seller's delivery to a carrier. Any delivery dates shown are approximate only and Seller shall have no liability for any delay in delivery.

**4. Warranty:** Seller warrants that the items sold hereunder shall be free from defects in material or workmanship for a period of 365 days from the date of shipment to Buyer, or 2,000 hours of use, whichever expires first. **THIS WARRANTY COMPRISES THE SOLE AND ENTIRE WARRANTY PERTAINING TO ITEMS PROVIDED HEREUNDER. SELLER MAKES NO OTHER WARRANTY, GUARANTEE, OR REPRESENTATION OF ANY KIND WHATSOEVER. ALL OTHER WARRANTIES, INCLUDING BUT NOT LIMITED TO, MERCHANTABILITY AND FITNESS FOR PURPOSE, WHETHER EXPRESS, IMPLIED, OR ARISING BY OPERATION OF LAW, TRADE USAGE, OR COURSE OF DEALING ARE HEREBY DISCLAIMED. NOTWITHSTANDING THE FOREGOING, THERE ARE NO WARRANTIES WHATSOEVER ON ITEMS BUILT OR ACQUIRED WHOLLY OR PARTIALLY, TO BUYERS DESIGNS OR SPECIFICATIONS.**

**5. Limitation Of Remedy: SELLER'S LIABILITY ARISING FROM OR IN ANY WAY CONNECTED WITH THE ITEMS SOLD OR THIS CONTRACT SHALL BE LIMITED EXCLUSIVELY TO REPAIR OR REPLACEMENT OF THE ITEMS SOLD OR REFUND OF THE PURCHASE PRICE PAID BY BUYER, AT SELLER'S SOLE OPTION. IN NO EVENT SHALL SELLER BE LIABLE FOR ANY INCIDENTAL, CONSEQUENTIAL OR SPECIAL DAMAGES OF ANY KIND OR NATURE WHATSOEVER, INCLUDING BUT NOT LIMITED TO LOST PROFITS ARISING FROM OR IN ANY WAY CONNECTED WITH THIS AGREEMENT OR ITEMS SOLD HEREUNDER WHETHER, ALLEGED TO ARISE FROM BREACH OF CONTRACT, EXPRESS OR IMPLIED WARRANTY, OR INTORT, INCLUDING WITHOUT LIMITATION, NEGLIGENCE, FAILURE TO WARN OR STRICT LIABILITY.**

**6. Changes, Reschedules and Cancellations:** Buyer may request to modify the designs or specifications for the items sold hereunder as well as the quantities and delivery dates thereof, or may request to cancel all or part of this order, however, no such requested modification or cancellation shall become part of the contract between Buyer and Seller unless accepted by Seller in an amendment to this Agreement. Acceptance of any such requested modification or cancellation shall be at Seller's discretion, and shall be upon such terms and conditions as Seller may require.

**7. Special Tooling:** A tooling charge may be imposed for any special tooling, including without limitation, dies, fixtures, molds and patterns, as required to manufacture items sold pursuant to this contract. Such special tooling shall be and remain Seller's property notwithstanding payment of any charges by Buyer. In no way will Buyer acquire any interest in apparatus belonging to Seller which is utilized in the manufacture of the items sold hereunder, even if such apparatus has been specially converted or adapted for such manufacture and notwithstanding any charges paid by Buyer. Unless otherwise agreed, Seller shall have the right to alter, discard or otherwise dispose of any special tooling or other property in its sole discretion at any time.

**8. Buyer's Property:** Any designs, tools, patterns, materials, drawings, confidential information or equipment furnished by Buyer or any other items which become Buyer's property, may be considered obsolete and may be destroyed by Seller after two (2) consecutive years have elapsed without Buyer placing an order for the items which are manufactured using such property. Seller shall not be responsible for any loss or damage to such property while it is in Seller's possession or control.

**9. Taxes:** Unless otherwise indicated on the face hereof, all prices and charges are exclusive of excise, sales, use, property, occupational or like taxes which may be imposed by any taxing authority. Upon the manufacture, sale or delivery of the items sold hereunder, if any such taxes must be paid by Seller or if Seller is liable for the collection of such taxes, the amount thereof shall be in addition to the amounts for the items sold. Buyer agrees to pay all such taxes or to reimburse Seller therefore upon receipt of its invoice. If Buyer claims exemption from any sales, use or other tax imposed by any taxing authority, Buyer shall save Seller harmless from and against any such tax, together with any interest or penalties thereon which may be assessed if the items are held to be taxable.

**10. Indemnity for Infringement of Intellectual Property Rights:**

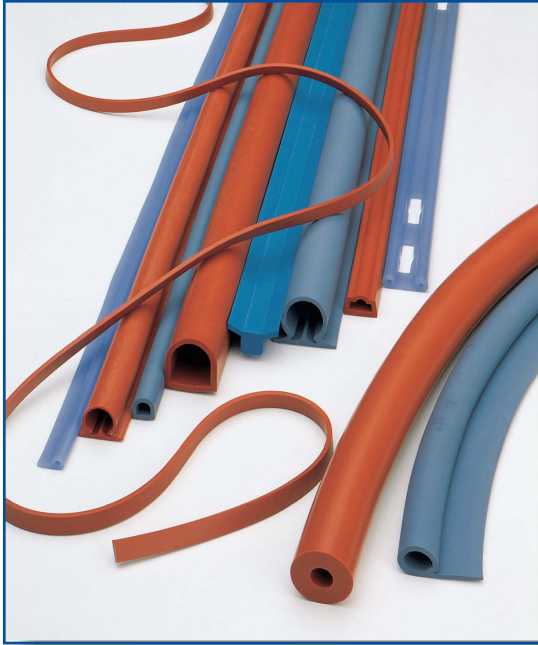
Seller shall have no liability for infringement of any patents, trademarks, copyrights, trade dress, trade secrets or similar rights except as provided in this Part 10. Seller will defend and indemnify Buyer against allegations of infringement of U.S. patents, U.S. trademarks, copyrights, trade dress and trade secrets (hereinafter "Intellectual Property Rights"). Seller will defend at its expense and will pay the cost of any settlement of damages awarded in an action brought against Buyer based on any litigation that an item sold pursuant to this contract infringes the Intellectual Property Rights of a third party. Seller's obligation to defend and indemnify Buyer is contingent on Buyer notifying Seller within Ten (10) days after Buyer becomes aware of such allegations of infringement, and Seller having sole control over the defense of any allegations or actions including all negotiations for settlement or compromise. If an item sold hereunder is subject to a claim that it infringes the Intellectual Property Rights of a third party, Seller may, at its sole expense and option, procure for Buyer the right to continue using said item or modify said item so as to make it non-infringing, or offer to accept return of said item and return the purchase price less a reasonable allowance for depreciation. Notwithstanding the foregoing, Seller shall have no liability for claims of infringement based on information provided by Buyer, or directed to items delivered hereunder for which the designs are specified in whole or part by Buyer, or infringements resulting from the modification, combination or use in a system of any item sold hereunder. The foregoing provisions of this Part 10 shall constitute Seller's sole and exclusive liability and Buyer's sole and exclusive remedy for infringement of Intellectual Property Rights.

If a claim is based on information provided by Buyer or if the design for an item delivered hereunder is specified in whole or in part by Buyer, Buyer shall defend and indemnify Seller for all costs, expenses or judgments resulting from any claim that such item infringes any patent, trademark, copyright, trade dress, trade secret or any similar right.

**11. Force Majeure:** Seller does not assume the risk of and shall not be liable for delay or failure to perform any of Seller's obligations by reason of circumstances beyond the reasonable control of Seller (hereinafter called "Events of Force Majeure"). Events of Force Majeure shall include, without limitation, accidents, acts of God, strikes or labor disputes, acts, laws, rules or regulations of any government or government agency, fires, floods, delays or failures in delivery of carriers or suppliers, shortages of materials and any other cause beyond Seller's control.

**12. Entire Agreement Governing Law:** The terms and conditions set forth herein, together with any amendments, modifications and any different terms conditions expressly accepted by Seller in writing, shall constitute the entire Agreement concerning the items sold, and there are no oral or other representations or agreements which pertain thereto. This Agreement shall be governed in all respects by the law of the State of Ohio. No actions arising out of the sale of the items sold hereunder or this Agreement may be brought by either party more than two (2) years after the cause of action accrues.

# Other TechSeal Products



TechSeal Division manufactures extruded rubber that can be processed as small diameter precision-cut seals, large diameter lathe-cut seals, special lathe-cut profiles, ParFab extruded profiles, ParFab spliced/fabricated gaskets and drive belts. TechSeal supplies products to a wide variety of industries including healthcare, telecommunications, military, aerospace, general industrial, plumbing, automotive and semiconductor markets.

## Compound Offering

TechSeal manufactures extruded products utilizing the following synthetic polymer families:

- Polyacrylate
- Neoprene
- SBR
- Thermoplastic
- Nitrile
- Fluorocarbon
- HNBR
- Silicone
- Fluorosilicone
- Butyl
- EPDM



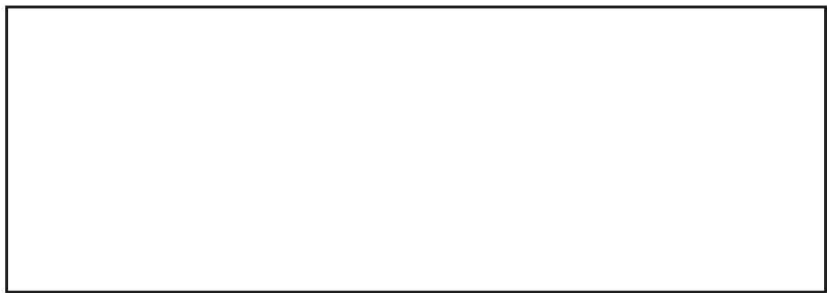
## Compound Specifications

TechSeal offers compounds that meet these specifications:

- ASTM - NSF - UL - FDA - USP Class VI
- MIL-SPEC - SAE - ZZ-R-765

## Size Offering

TechSeal offers extruded and precision-cut seals from 0.030" up to 18.0" ID with walls as thin as 0.010" (depending on OD). These seals can be cut into washers and other sealing configurations as thin as .020". TechSeal also offers custom extruded profiles in long lengths (with or without Pressure Sensitive Adhesive), spliced solid or hollow o-rings and ParFab fabricated four-corner gaskets.



Your Local Authorized Parker Distributor



Parker Hannifin Corporation  
**TechSeal Division**  
3025 West Croft Circle  
Spartanburg, SC 29302  
phone 864 573 7332  
fax 864 583 4299  
[www.parker.com](http://www.parker.com)