

aerospace
climate control
electromechanical
filtration
fluid & gas handling
hydraulics
pneumatics
process control
sealing & shielding

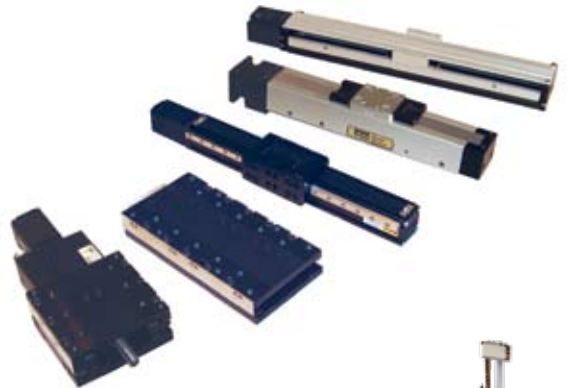

Daedal Electromechanical Positioning Systems

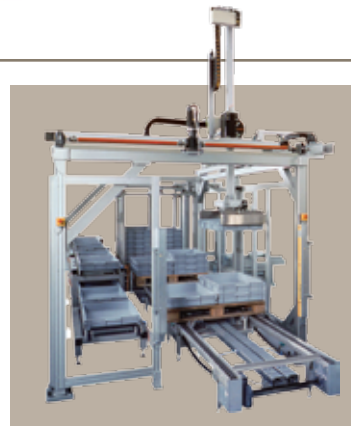

ENGINEERING YOUR SUCCESS.

www.comoso.com

Parker Hannifin Corporation

A Fortune 300 company with annual sales exceeding \$10 billion and more than 400,000 customers in 43 countries, Parker Hannifin is the world's leading supplier of innovative motion control components and system solutions serving the industrial, mobile, and aerospace markets. We are the only manufacturer offering customers a choice of electromechanical, hydraulic, pneumatic, or computer-controlled motion systems.

Total System Solutions

Parker's team of highly qualified application engineers, product development engineers, and system specialists can turn pneumatic, structural, and electromechanical products into an integrated system solution. Moreover, our Selectable Levels of Integration™ allows you to choose the appropriate system, subsystem, or component to meet your specific need.

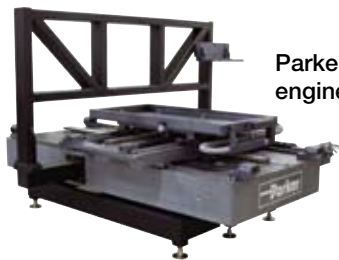

Parker offers complete engineered systems.

First in Delivery, Distribution, and Support

In today's competitive, fast-moving economy, what good is an application that isn't ready on time? This is especially true when compressed design cycles make the quick delivery of critical components essential. With factories strategically located on five continents, Parker offers an unrivaled delivery record, getting solutions out our door and onto your floor faster than ever.

Parker also has the industry's largest global distribution network, with more than 8,600 distributors worldwide. Each of these locations maintains ample product inventory to keep your downtime to a minimum. And many distributors have in-house design capabilities to support your system and subsystem requirements.

Throughout the design process, Parker's factory-trained electromechanical engineers work hand in hand with you and day or night at 1-800-C-Parker. Our operators will connect you with a live, on-call representative who will identify replacement parts or services for all motion technologies.



© Copyright 2008, Parker Hannifin Corporation. All rights reserved.



Parker world headquarters in Cleveland



Training

Parker's best-in-class technology training includes hands-on classes, Web-based instruction, and comprehensive texts for employees, distributors, and customers. Parker

also provides computer-based training, PowerPoint presentations, exams, drafting and simulation software, and trainer stands.

parkermotion.com

Our award-winning Web site is your single source for

- Product information
- Downloadable catalogs
- Motion-sizing software
- 3D design files
- Training materials
- Product-configuration software
- RFQ capabilities
- Videos and application stories



24/7 Emergency Breakdown Support

The Parker product information center is available any time of the day or night at 1-800-C-Parker. Our operators will connect you with a live, on-call representative who will identify replacement parts or services for all motion technologies.

Table of Contents

Introduction

- 2-3 Parker Partners in Automation & Support
- 4-5 Selectable Levels of Integration™
- 6-7 Parker Products and Technologies
- 8-9 Daedal Products and Technologies
- 10-12 Daedal Engineered Solution Examples

Linear Servo Motor Driven Tables

- 13-28 400LXR Series

Screw Driven Automation Tables

- 29-33 Overview
- 34-63 400XR Series Square Rail Linear Tables
- 64-69 XRS Cartesian Systems
- 70-79 402/403XE Series Positioners
- 80-89 404XE Series
- 90-111 HD Series Linear Positioners
- 112-127 Ultra Series Crossed Roller Ultra Precision Stages
- 128-133 100CT & 800CT Series
- 134-137 200RT Series
- 138-141 Rotary Series Worm Driven Precision Stages
- 142-145 ZP200 Series Vertical Lift "Wedge" Table
- 146-150 Additional Products

Miniature Positioners – Linear Motor & Screw Driven

- 151-153 Overview
- 154-161 MX80L Linear Motor Driven Stages
- 162-167 MX80S Ballscrew/Leadscrew Driven Stages
- 168-171 MX80M Free Travel & Micrometer Driven
- 172-179 LX80L Linear Motor Tables
- 180-187 PROmech LP 28 Miniature Linear Positioners
- 188-193 PROmech LD 28 Miniature Linear Positioners
- 194 PROmech LD 28 Miniature Linear Positioners

Belt Driven High-speed Automation Tables

- 195-199 Overview
- 200-213 HPLA Series
- 214-227 HLE-RB
- 228-239 HLE-SR
- 240-245 HLE-Z
- 246-251 HZR
- 252-253 BLMA
- 254-271 Gantry Robot Configurations
- 272-276 HPLA/HLE Options and Accessories
- 277-280 Additional Products

Drives and Controllers

- 282-283 Planetary Gearheads
- 284-285 Rotary Servo Motors
- 286 Frameless Motors
- 287-289 Servo Drives & Controller Drives
- 290 Stepper Drives & Controller Drives
- 291 ACR Motion Controllers
- 292 Real-Time Ethernet Motion Control
- 293-295 HMI Human Machine Interfaces

Engineering Reference

- 297-326

Welcome!

Thank you for your interest in the products and systems offered by Parker Hannifin Corporation's Electromechanical Automation Division. This catalog presents Parker's "perfect fit" electromechanical solutions for high-precision positioning and high-speed automation. Our products and systems are recognized around the world for their functionality, performance, and reliability.

The products illustrated in this catalog can be combined to form single- or multi-axis systems. These systems are offered at *Selectable Levels of Integration™* ranging from basic single-axis mechanical tables and actuators... to multi-axis mechanical subsystems... to complete electromechanical systems and robots including motors, drives, controls, and machine interface.

As you read through this catalog, you will discover that Parker offers the widest variety of electromechanical solutions that are delivered in the shortest amount of time. Still, many customers require special solutions to satisfy unique or special requirements. Parker has been providing custom engineered solutions for over 30 years to satisfy those requirements. If your application cannot be fulfilled by the complement of products found in this catalog, please contact an authorized Parker Automation Technology Center or a factory applications engineer.

We are proud to present to you a complete spectrum of positioning and motion control products. We invite you to discover the advantages that can be realized by relying on Parker for products and systems which represent the very best value in the electromechanical marketplace.

Sincerely,



Ken Sweet
General Manager

Linear Motor
Driven Tables

Screw Driven
Tables

Miniature
Positioners

Belt Driven
Tables

Drives &
Controllers

Engineering
Reference



Today's automation applications demand performance in quality throughput, productivity and precision. Miniaturization of semiconductor, electronics and life science applications have created the need to partner with companies that have the experience and products to meet stringent specifications for smaller, more precise motion control solutions.

Parker's dedicated electromechanical business is rapidly becoming an industry leader in providing precision connectivity to PC-based controls for target industries including:

- Semiconductor
- Electronics
- Computer Peripherals
- Life Science
- Medical Equipment



In the industrial markets, solutions from Parker's Electromechanical Automation Division combine speed, accuracy and high-load capacities to give machine builders and OEMs a competitive edge in applications including:

- Packaging
- Automotive Manufacturing and Assembly
- Printing
- Material Handling
- Military Applications

Parker is about motion control engineering, manufacturing, application expertise and unparalleled customer service. Our electromechanical systems and solutions are available wherever needed—around the corner or around the world.

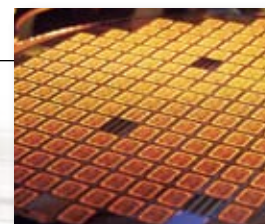

Customization and Services

Unlike many other motion technologies, electromechanical applications often require custom solutions. Parker has a Custom Systems Group staffed by experienced engineers and technicians who utilize systematic processes for handling component modifications or complete one-of-a-kind systems.

The System is the Product

Many of the industrial systems shown in this catalog are built specifically to customer request and need. Parker system customers can receive many optional services such as:

- 3-D Custom Assembly Drawings
- Electronics Integration
- Finite Element Analysis
- Life Load Testing
- End Effector Integration
- High-Flex Cabling Systems



Our advanced manufacturing and assembly process allows us to build quality and consistency into every element of your motion system. Each mechanical system is fully assembled prior to shipment and each component is properly handled to protect finish and appearance. Performance and specifications are verified with state-of-the-art testing, including:

Cleanroom Testing

Parker is equipped with particulate testing to certify materials for cleanroom ratings.



EMI Testing

Parker has an EMI test chamber, which allows us to test equipment to verify levels of electromagnetic interference.

Precision Metrology Lab

When precision is critical to your process, you need validated, proven performance data. Parker certifies all precision-grade positioners using state-of-the-art laser interferometers, and provides reports to validate accuracy and bidirectional repeatability.

24/7 Emergency Breakdown Referrals

The Parker product information center at 800-C-PARKER offers live operators 24/7 to help identify replacement parts or services.

Parker Automation Technology Centers

Parker Automation Technology Centers are a network of premier product and service providers who can serve you locally for your automation needs. Each Automation Technology Center is certified to have completed significant product training and has the ability to provide subsystem solutions with local support.

Industry's Best Lead Times

#1 rated, industry-leading, on-time delivery to customer-requested ship dates.

www.parkermotion.com

The Parker Electromechanical Automation site offers the most extensive online support tools in the industry, including:

- Complete online catalog
- FAQ database with more than 500 answers to common questions
- Interactive product sizing and selection tool
- Comprehensive CAD drawings and 3-D models for electronic and mechanical products
- User guides and detailed product specifications
- Latest software and firmware revisions
- Application case studies and videos
- Custom solutions photo library
- Innovative technology white papers

One-on-One with a Motion Control Expert

Toll-Free Applications Engineering Assistance

When you have urgent questions, expert answers are only a phone call away. Our team of experienced engineers is ready to take your call. These engineers have practical field experience and can provide you with application and product assistance throughout the stages of your project and for the life of the product. For presale support, including sizing and selecting systems, call 800-245-6903 (724-861-8200 outside the US). For post-sale support with technical questions on programming and troubleshooting, call 800-358-9070 (707-584-7558 outside the US). Our staffing and support tools allow us to resolve most issues and get your project rolling in less than one hour.

Parker's Selectable Levels of Integration™ is a philosophy of product development and management that allows the machine builder to select an appropriate system, subsystem, or component to meet a specific need.

Parker has solutions for machine builders of all types, from those who want a complete integrated system to those who want to build their own system from "best of breed" components.

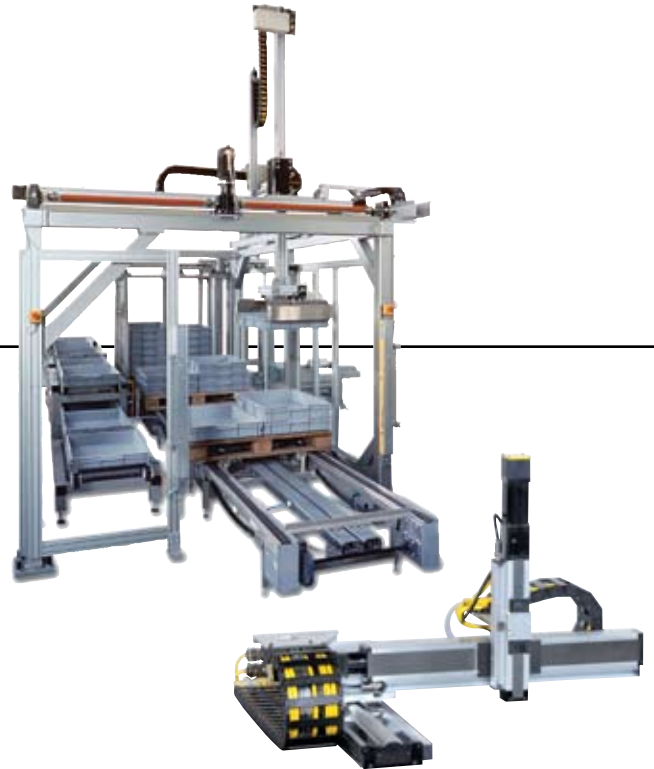

Systems

Machine builders and OEMs often choose to integrate a complete electromechanical system into their machine. They have confidence in knowing that our knowledge, experience, and support will ensure that their goals are met. Minimal design engineering ensures component compatibility from a single source.

Subsystems and Bundled Products

For a cost-effective and efficient solution, Parker offers bundled or kitted systems. We can combine motors, gearheads, and positioning systems to deliver a configured subsystem ready for installation. Parker configuration and setup software accommodates the rest of the product line, making start-up a snap. Combining this with our custom product modification capabilities gives the machine builder an economical custom-fit solution, with reduced engineering effort, straightforward integration, and modular compatibility.



Component Products

We offer the broadest range of linear and rotary motion products available for automation systems. If you have the capability and experience to develop your own systems, our innovative, easy-to-use products will help you get the job done. Parker provides short lead times, large selection, and proven reliability.





Parker Electromechanical Automation Division products are built using industry standard interfaces and market-leading features that combine great value and performance. Whether using one component or an entire system, Parker has the right solution.



HMI (Human-Machine Interface)

Parker offers HMI solutions for any application from simple pushbutton replacement to sophisticated networking, multimedia and data logging requirements. Parker pre-loads Interact or InteractX HMI software on PowerStation industrial computers to provide a ready-to-go HMI solution. This bundled approach reduces development and integration time for your HMI project.



Motion Controllers

Parker motion controllers are powerful designs that have the processing power to coordinate multiple axes of motion. Parker controllers have advanced features built in, such as kinematics transformation for the control of robots and other non-linear functions. Each Parker controller comes with free libraries for Visual Basic® and Visual C++®.





Drives

Parker drives are digital designs that deliver a maximum amount of power output and performance in minimal package size. These drives have industry-leading power density and smart digital designs with features to ease integration and start-up.



Motors

Using advanced technologies, Parker rotary motors provide maximum performance and value. Our exposed-lamination designs provide maximum torque per package size, and the motor designs provide cog-free rotary motion for the best low-speed smoothness. Patented linear motor designs provide the greatest winding uniformity and accuracy in the industry, and range from the smallest linear motor on the market to the largest force capacity.



Gearheads

High-precision designs, Parker gearheads have less than three arc-min of backlash. They have an industry-leading two-year warranty.



Positioning Tables

Parker multi-axis positioning tables integrate linear motors or ground ballscrews. The designs combine the low cost of extruded aluminum with machined bases allowing “out of the box” submicron precision. Our positioning tables are modular designs that easily accommodate flexible configurations such as XY and XYZ.



Actuators

Parker actuators are modular single-axis actuators that can be easily configured in multi-axis systems. These actuators are screw- or belt-driven and give the designer a great deal of flexibility to apply the right actuator technology to meet the application needs for accuracy, speed and distance.



End Effectors

With the broadest range of automation products in the industry, Parker provides pneumatic grippers, rotary actuators and vacuum components for a wide range of applications.



Structural Framing

Parker Industrial Profile Systems provide full engineering, fabrication and assembly for any structural design. We provide the profiles, fasteners and accessories to complete any system. The only limitation is your imagination.



I/O

The Parker I/O system is a modular and flexible remote I/O system designed to work with today's common fieldbuses. The modular design of the Parker I/O allows the user to choose the number and type of I/O points that best suit each application.





Systems

Parker's systems combine the breadth of our motion control solutions into XY systems, Cartesian robots, gantry systems, or completely custom configurations.

This catalog is divided into several sections based on primary distinguishing characteristics such as drive technology, degree of precision, travel range, and acceleration.

If you don't find what you are looking for, please contact us for information on other suitable Daedal and Parker products.



Linear Motor Driven Tables	<p>Drive Mechanisms</p> <ul style="list-style-type: none"> • Linear Servo Motor • Direct Drive Rotary Motor <p>Bearing Systems</p> <ul style="list-style-type: none"> • Square Rail 
Screw Driven Tables	<p>Drive Mechanisms</p> <ul style="list-style-type: none"> • Ground Ballscrew • Ground Leadscrew • Rolled Ballscrew • Worm Gear <p>Bearing Systems</p> <ul style="list-style-type: none"> • Square Rail • Round Rail • Linear Ball & Rod • Cross Roller 
Miniature Positioners	<p>Drive Mechanisms</p> <ul style="list-style-type: none"> • Linear Servo Motor • Ground Ballscrew • Rolled Leadscrew <p>Bearing Systems</p> <ul style="list-style-type: none"> • Square Rail • Cross Roller 
Belt Driven Tables	<p>Drive Mechanisms</p> <ul style="list-style-type: none"> • Timing Belt • Linear Servo Motor • Rack-and-Pinion <p>Bearing Systems</p> <ul style="list-style-type: none"> • Polyamide Wheel • Steel Wheel • Square Rail 

Visit our Website

Complete up-to-date technical assistance can be found on the web at www.parkermotion.com. This includes all the latest information on current products, new product introductions, local assistance and support, plus a comprehensive "Engineering Reference Library."

- Complete Product Catalog
- Product Selection Wizards
- Performance Charts and Graphs
- Engineering Data and Calculations
- CAD Drawings
- Local Service and Support Directory
- On-Line Purchasing
- Application stories and videos



Style	Model	Drive Type				Bearing Type	Precision – μm			Max. Travel mm	Normal Load		Profile Width mm	Max. Speed mm/s	Page	Recommendation
		Ground Ballscrew	Rolled Ballscrew	Rolled Ballscrew	Lead screw		≤ 30	31-99	≥ 100		N	(lbs)				
Screw Driven Positioners	Standard	404XR	•			Square Rail	•	•		700	1700	(375)	100	1200	34-63	Best
		406XR	•			Square Rail	•	•		2000	6300	(1390)	150	1200	34-63	Best
		412XR	•			Square Rail	•	•		2000*	14700	(3241)	300	1175	34-63	Best
		HD085	•			Square Rail	•	•	•	1200	1700	(375)	85	1480	90-111	Better
		HD125	•			Square Rail	•	•	•	1600	6300	(1390)	125	1480	90-111	Better
		HD185	•			Square Rail	•	•	•	2000*	14700	(3241)	185	1480	90-111	Better
		402XE		•		Recirculating Ball	•	•		255	900	(205)	50	450	70-79	Good
		403XE		•		Recirculating Ball	•	•		655	1600	(360)	60	800	70-79	Good
		404XE		•		Square Rail	•	•	•	700	1700	(382)	100	1440	80-89	Good
		CT		•		Cross Roller	•	•		300	1280	(290)	127 – 203	250	128-133	Good
		ER		•		Roller Wheel	•	•	•	1500	2224	(500)	45 – 70	1270	(3)	Good
		ET		•		Roller Wheel	•	•	•	2000*	44482	(10000)	47 – 140	1524	(3)	Good
		Ultra		•		Cross Roller	•	•		500	21447	(4821)	200 – 600	300	112-127	Better
		LN		•		Square Rail	•	•		150	715	(160)	50	375	PDF**	Good
Miniature	LP28			•	Square Rail			•	500	97	(22)	28	380	180-187	Better	
	LD28			•	–			•	300	44	(10)	28	380	188-193	Good	
	MX80S		•	•	Cross Roller	•	•		150	80	(18)	80	200	162-167	Best	

Style	Model	Drive Type			Bearing Type	Precision – μm			Max. Travel mm	Normal Load		Profile Width mm	Max. Speed mm/s	Page	Recommendation	
		Slotless	Ironless	Ironcore		≤ 30	31-99	≥ 100		N	(lbs)					
Linear Motor Driven	High-Precision	404LXR	•			Square Rail	•	•		1000	1700	(375)	100	3000	13-28	Best
		406LXR	•			Square Rail	•	•		1950	6300	(1390)	150	3000	13-28	Best
		412LXR	•			Square Rail	•	•		3000*	14700	(3241)	300	3000	13-28	Best
		Ultra		•		Cross Roller	•	•	•	500	21447	(4821)	200 – 600	1500	112-127	Best
	High-Precision Miniature	MX80L		•		Cross Roller	•	•		200*	80	(18)	80	2000	154-161	Best
		LX80		•		Square Rail	•	•		750	60	(13)	80	3000	172-179	Better
	Industrial Grade	T		•		Square Rail	•	•		4060*	900	(200)	170 – 235	5000	(2)	Better
		TR		•		Square Rail	•	•		2655*	4500	(990)	203 – 350	5000	(2)	Better
		BLMA		•		Roller Wheel	•	•		6300	3000	(674)	120	7000	252-253	Good

Style	Model	Drive Type	Bearing Type	Precision – μm			Max. Travel mm	Normal Load		Profile Width mm	Max. Speed mm/s	Page	Recommendation
				≤ 30	31-99	≥ 100		N	(lbs)				
Belt Driven Products	HPLA080	Belt	Steel/Polyamide Roller Wheel			•	5540	3000	(674)	80	5000	200-213	Best
	HPLA120	Belt	Steel/Polyamide Roller Wheel			•	9470	6000	(1358)	120	5000	200-213	Best
	HPLA180	Belt	Steel/Polyamide Roller Wheel			•	9240	15000	(3372)	180	5000	200-213	Best
	HLE60RB	Belt	Roller Wheel			•	4000	650	(150)	60	5000	214-227	Best
	HLE100RB	Belt	Roller Wheel			•	6200	1140	(256)	100	5000	214-227	Good
	HLE150RB	Belt	Roller Wheel			•	7900	2280	(512)	150	5000	214-227	Good
	HLE60SR	Belt	Square Rail			•	3000	680	(157)	60	3000	228-239	Best
	HLE100SR	Belt	Square Rail			•	6150	1680	(377)	100	3000	228-239	Better
	LCB	Belt	Sliding Bearing			•	5500	295	(66)	40 – 60	7000	(3)	Good
	ERV	Belt	Roller Wheel			•	6050	3590	(807)	56 – 80	5000	(3)	Better
	ER	Belt	Roller Wheel			•	4550	222	(50)	45	5000	(3)	Good
	HZR	Belt	Roller Wheel			•	1500	1500	(310)	50 – 100	5000	246-251	Better

Other Products	Drive Type	Bearing Type	Precision – μm			Max. Travel mm	Normal Load		Profile Width mm	Max. Speed mm/s	Page	Recommendation
			≤ 30	31-99	≥ 100		N	(lbs)				
Rotary	Worm / Direct Servo	Ball Bearing	•	•		–	3250	(715)	100 – 300	30 RPM	134-141	Better
Wedge Positioners	Ball Screw	Square Rail		•		25	750	(165)	200	440	142-145	Better
Manually Driven	Micrometer	Cross Roller/ Ball	•	•		600	2200	(500)	8 – 200	–	PDF**	Best
Rack and Pinion	Belt/Rack	Roller Wheel		•		8870	15000	(3372)	150 & 180	5000	240-245	Better

* Longer travel lengths available by special order.

** PDF documents are available on our website at www.parkermotion.com

(2) See Catalog 96-028778-01

(3) See Catalog AU03-1894-02/US



The majority of today's positioning and motion control systems are involved in processes associated with "making" (manufacturing), "moving" (transferring), or "measuring" (testing).

Parker's electromechanical systems are utilized extensively in all three areas. This is attributed to our ability to provide "Perfect Fit" solutions covering a broad spectrum of requirements at various levels of integration and complexity.

Below and on the following pages are several examples of Daedal engineered Parker systems for customer-specific applications.



Making

The application examples shown here are a small sample of the multitude of manufacturing processes where Parker system solutions are being utilized. From factory floors to cleanrooms, Parker provides versatile motion systems and subsystems that maximize manufacturing productivity.

Automotive Component Assembly Machine

Tooling station positioner to replace mechanical cam.

- 6 inch vertical travel with electromechanical brake on ballscrew
- 0.0002 inch position repeatability
- Dowel holes in table base and carriage for precise mounting
- Strip seals on table to keep fingers and debris out of table

Catheter and Stent Manufacturing for Medical Industry

XY positioning for micromanufacturing of precision instruments.

- Miniature positioners with NEMA 16 servo motors
- 0.00002 inch resolution with linear encoder feedback
- Continuous duty cycle
- Precision grade tables with special laser interferometer testing



Sealant Dispensing for Engine Rocker Covers ①

Contour path – CAD to motion.

- XYZ (18 in x 14 in x 6 in) work area
- High stiffness tables for cantilevered mounting
- Cable carriers for multi-axis system
- Precision ground ballscrews for smooth, quiet operation

Rapid Prototype Machines ②

Automated process for fabricating dense metal parts by fusing metal powder within the focal beam of a laser.

- Combined linear motor, ballscrew and belt drive technologies
- Complete with machine base and cable management system
- Special straightness and flatness testing
- Custom engineered brackets

Food and Beverage Packaging ③

Filling machine in washdown environment.

- Stainless steel construction
- FDA approved lubrication
- 30 inch travel; 50 lb load
- Continuous duty at 120 in/sec velocity; 3 g acceleration

Moving

The application examples shown here illustrate the types of material handling applications routinely solved by Parker system solutions. From overhead gantry robots to tabletop XY positioners, Parker provides the widest spectrum of material handling application solutions in the industry.

Electric Motor Container Handling ①

Automated transfer of product from conveyor to labeler to pallet.

- XYZ (80 in x 60 in x 40 in) work area
- Per axis repeatability of 0.004 inch
- Complete cable management system
- Custom end effector

Multi-Pick Storage and Retrieval System ②

Programmable order picker

- XYZ (20 ft x 13 ft x 3 ft) work area
- High dynamics (2 g accel.; 80 in/sec vel.)
- Custom end effectors

Genomic Specimen Handling ③

Accurate placement of 96, 384, or 1536 well microtiter plates for DNA sequencing and analysis

- XY (24 in x 20 in) work area
- Modular motion platform integrates into OEM machinery
- Attractive packaging of XY table with stainless steel protective covers
- Cleanroom compatible

Machine Tool Loader/Unloader ④

Automated machine tending for top entry machine access

- XZ (10 ft x 3 ft) work area
- 60 in/sec velocity requirement
- Clean cable / air hose routing
- Payloads up to 130 lb

Palletizer for Pharmaceutical Products

Product loading on automated guided vehicle

- XYZ (15 ft x 6 ft x 6 ft) work area
- Pneumatic rotary axis
- Custom end effector
- Overhead gantry mechanics allow floor space utilization

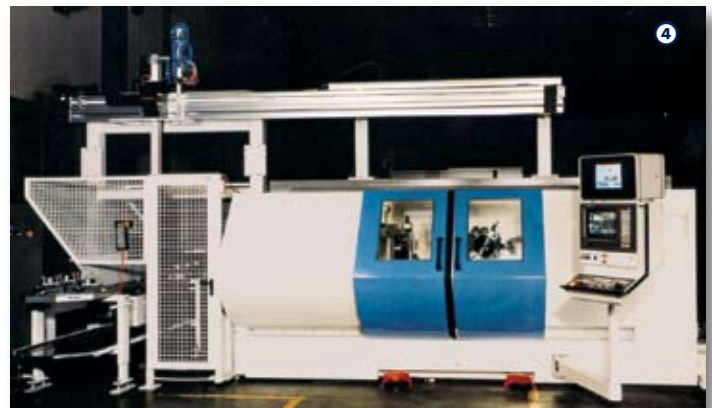
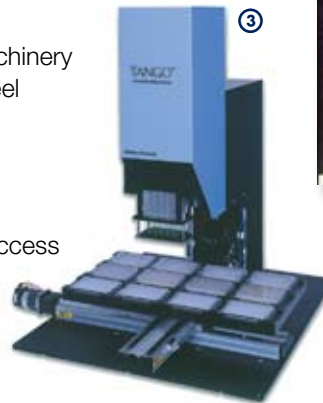
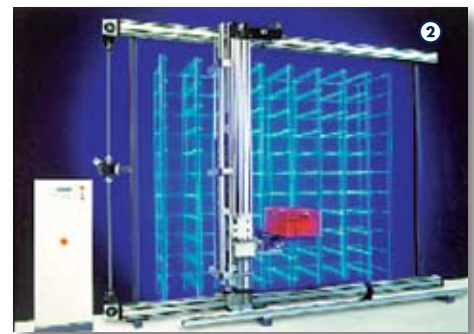

Measuring

The examples shown here showcase Parker's ability to provide high-precision motion solutions for critical test and measurement applications. From miniature microscope mounted positioners to steel framed test systems, Parker provides solutions for the widest range of precision applications and ensures performance with laser testing and certification.

Surface Measurement of Turbine Blades

Precise positioning of contact probes.

- Custom 5-axes motion mechanics
- Complete with machine base and cable management system
- Special laser interferometer certification
- Heavy duty construction to minimize deflection

Flying Height Tester

Position a test specimen to simulate hard disk drive reader head operation.

- 6 in x 4 in XY travel designed for high accuracy
- Special materials for extreme rigidity and low ESD
- Cleanroom compatible mechanical system
- Special point of measurement laser interferometer testing



Wafer Inspection

Vision system raster scan.

- 350 mm x 350 mm work area
- Continuous duty cycle
- Cleanroom compatible mechanics
- Precision ballscrew or linear motor drive options

Inspection of Composite Parts for Aerospace Industry ①

Precision positioning of 300 lb test specimen relative to fixed test beam.

- 40 in x 20 in x 360° work envelope
- All axes of motion aligned to test beam for entire travel range
- Custom 16 ft x 8 ft x 5 ft steel machine frame
- Complete with control panel and cable management system

Camera Calibration Rig ②

Calibration of video camera used in space for vital display information.

- Ballscrew driven XYZ system with extended travel (144 in x 24 in x 24 in)
- Custom engineered brackets
- Pinned orthogonal
- Repeatable within 0.0005 in

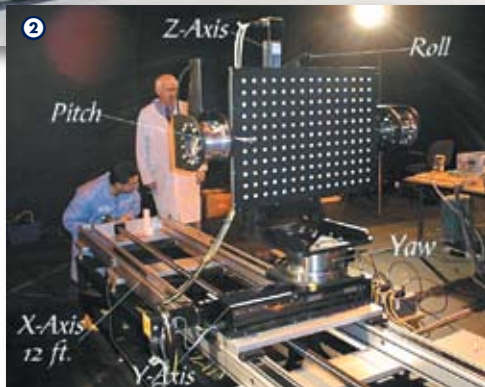

Linear Motor Driven high-speed, high-precision tables



Positioning systems needed for many of today's high-technology applications must satisfy an ever-increasing demand for high throughput and the need for extreme precision. Semiconductor, fiber optics, computer peripherals, metrology, solar scribing, digital printing, and other high-end industries require positioning systems which demonstrate quick response, high acceleration, high velocity, and fast settling time, in conjunction with micron and submicron level positioning. Parker's linear motor product group is designed to satisfy this attribute combination of performance and precision. Products and systems in this section feature advanced direct-drive technology, which enables payloads to be directly driven by highly efficient brushless servo motors.

Contents

14-15	Overview
16	Specifications
17	Cable Management
18	Digital Drive Options
19	Cleanroom Option
20	404LXR Dimensions
21	404LXR Ordering Information
22	406LXR Dimensions
23	406LXR Ordering Information
24	412LXR Dimensions
25	412LXR Ordering Information
26-28	Additional Products

400LXR Series Linear Motor Tables

Linear motors cannot function on their own. Before motion can occur, a platform must be engineered to provide support, direction, and feedback for the linear motor. Bearings, cables, connectors, encoder, travel stops, homing sensor and other components must be performance matched and integrated to achieve desired motion and control.

Parker linear motor tables provide all this and more in a pre-engineered, easily mounted, ready to run package. The linear motor magnet rail is mounted to a stationary base and the forcer is mounted to the moveable carriage. The only contact between the moving carriage and the stationary base is through the linear support bearings. High-precision square rail bearings provide load support, low-friction translation, and a precise linear path. A high resolution linear encoder provides the required velocity and positional information to the motor controller, and a unique cable management system enables high performance motion with a life of 30 million cycles and beyond.

Parker tables, with the slotless linear motor, are offered in three sizes: 404LXR, 406LXR, and 412LXR.

- Pre-engineered package
- Performance matched components
- Protection from environment
- Laser certified precision



Performance Matched Components

The 400LXR Series linear servo motor tables achieve optimum performance by combining slotless motor technology with performance matched mechanical elements and feedback devices. Fast response, high acceleration, smooth translation, high velocity, and quick settling time describe the performance characteristics found in the 400LXR while high repeatability, precise accuracy, and sub-micron resolution define the positioning attributes.

Sized to Fit

The 400LXR Tables are offered in three widths (100, 150, and 300 mm), and travel lengths up to 3 meters to accommodate the size and performance requirements of many industries including life sciences, photonics, semiconductor, digital printing, solar panel, and general automation.



“Designer Friendly” Features and Options

A vast assortment of “designer friendly” features and options simplify the engineering challenges often confronted with “base model” positioning devices. Features like the IP30 protective strip seal and long life cable management system exemplify the built-in value found in the 400LXR units. Other selectable enhancements like cleanroom compatibility, travel limit sensors, motor drives, encoder resolution, and pinning holes for tooling location, simplify machine design and integration efforts.





Flexibility and Multi-Axis Compatibility

The 400LXR's selection flexibility and mounting compatibility with the 400XR ballscrew driven tables enables single-axis or complex multi-axis units to be configured in a straightforward manner.

Parker's matching servo drives and motion controllers can be included to complete the motion system.



Customs and Systems

For specialized applications requiring customization, Parker design engineers can easily modify these tables to suit, or engineer complete interactive linear motion systems to desired specifications.

Parker's 400LXR series tables have taken the mystery, difficulty and cost out of integrating linear motor tables into high throughput precision positioning applications.



Linear Motor Driven Tables

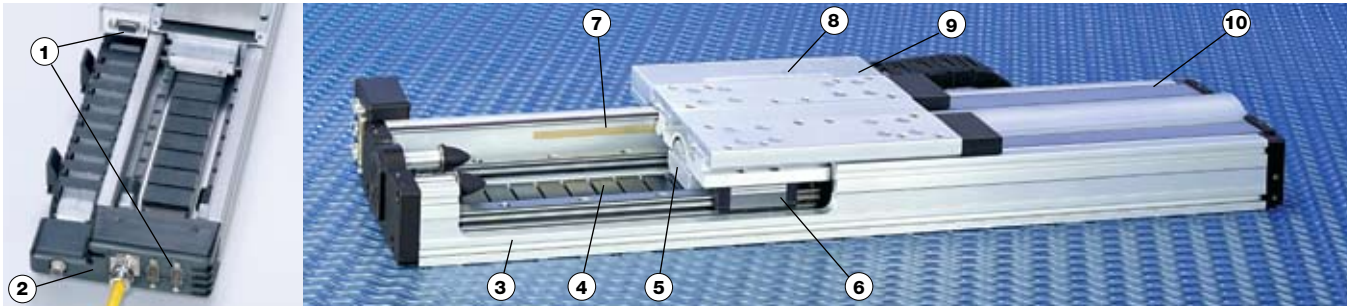

1 "Pass-Through" Cabling

Pre-wired, plug-in connection of the moving payload for easy hookup of user instruments or end effectors.

2 Connector Panel

Electrically shielded panel provides "plug-in" connectivity and quick disconnect for all signal and power requirements.

3 High Strength Aluminum Body

Extruded aluminum housing is precision machined to provide outstanding straightness and flatness.

4 Magnet Rail

Single rail of high energy rare earth magnets offers lower weight and lower cost than double magnet type.

5 Slotless Linear Motor

Provides a highly responsive, zero backlash drive system. Slotless motors offer excellent heat management, durability, and have built-in thermal sensor and hall sensors.

6 Linear Guidance System

The highly engineered carriage and bearing system effectively counters the combined problematic effects of heat, high-speed and high acceleration.

7 Integral Linear Encoder

Protected non-contact feedback with selectable resolutions to 0.1 micron. Z channel is factory aligned to home sensor for precise homing.

8 Limit/Home Sensors

Proximity sensors establish end of travel and "home" location and are easily adjustable over entire length to restrict the travel envelope.

9 "Quick Change" Cabling

Innovative cable transport module offers extended life (30 million cycles) and a simple cable changing system for preventative maintenance.

10 Protective Seals

Hard shell aluminum cover combined with stainless steel strip seals provide IP30 protection to interior components as well as enhances overall appearance.



Model		404LXR	406LXR		412LXR
Motor		8 Pole	8 Pole	12 Pole	12 Pole
Rated Load	kg (lb)	45 (99)	180 (396)	180 (396)	950 (2090)
Maximum Acceleration		5 Gs			
Maximum Velocity	(m/sec)				
Encoder Resolution:					
0.1 µm		0.3	0.3	0.3	0.3
0.5 µm		1.5	1.5	1.5	1.5
1.0 µm		3.0	3.0	3.0	3.0
5.0 µm		3.0	3.0	3.0	3.0
Sine Output		3.0	3.0	3.0	3.0
Positional Repeatability					
Encoder Resolution:					
0.1 µm			± 1.0 µm		
0.5 µm			± 1.0 µm		
1.0 µm			± 2.0 µm		
5.0 µm			± 10.0 µm		
Sine Output			(Interpolation Dependent)		
Peak Force	N (lb)	180 (40)	225 (50)	330 (75)	1000 (225)
Continuous Force	N (lb)	50 (11)	75 (17)	110 (25)	355 (80)
Carriage Mass	(kg)	1.4	3.2	4.1	12.3

Travel Dependent Specifications

Travel (mm)	Accuracy* (µm)			Unit Weight (Kg)			
	Positional Resolution	Straightness & Flatness		404LXR	406LXR	406LXR	412LXR
				8-Pole	8-Pole	12-Pole	12-Pole
	0.1						
	0.5						
	1.0						
50	6	16	6	4.4	8.7	11.1	–
100	7	17	6	4.8	–	–	–
150	8	18	9	5.2	10.3	13.4	41
200	10	20	10	5.6	–	–	–
250	12	22	12	6.0	12.6	14.1	45
300	14	24	13	6.4	–	–	–
350	16	26	15	6.8	13.3	15.7	49
400	18	28	16	7.2	–	–	–
450	20	30	18	–	14.8	17.2	–
500	21	31	19	8.0	–	–	–
550	23	33	21	–	16.4	18.7	–
600	25	35	22	8.9	–	–	–
650	26	36	24	–	17.9	20.2	61
700	28	38	25	9.7	–	–	–
750	29	39	27	–	19.4	21.8	–
800	31	41	29	10.6	–	–	67
850	32	43	30	–	20.9	23.3	–
900	33	44	32	11.5	–	–	–
950	34	44	33	–	22.5	–	–
1000	35	45	35	12.4	–	27.1	75
1050	37	47	36	–	–	–	–
1200	39	49	41	–	26.3	–	83
1350	42	52	45	–	–	30.9	–
1450	43	53	48	–	30.1	–	–
1500	44	54	50	–	–	–	95
1600	45	55	53	–	–	34.7	–
1700	46	56	56	–	33.9	–	–
1750	46	56	57	–	–	–	105
1850	47	57	60	–	–	38.6	–
1950	48	58	63	–	37.7	–	–
2000	48	58	65	–	–	–	113
2350	49	59	76	–	–	–	–
2500	50	60	80	–	–	–	133
2850	50	60	84	–	–	–	–
3000	50	60	84	–	–	–	153

* Accuracy stated is at 20° C, utilizing slope correction factor provided

Encoder Specifications

Description	Specification
Input Power	5 VDC ±5% 150 mA
Output (Incremental)	Square wave differential line driver (EIA RS422) 2 channels A and B in quadrature (90°) phase shift.
Reference (Z Channel)	Synchronized pulse, duration equal to one resolution bit. Repeatability of position is unidirectional moving toward positive direction.

Limit and Home Specifications

Description	Specification
Input Power	+5 to +24 VDC 60 mA (20 mA per sensor)
Output	Output form is selectable with product: Normally Closed Current Sinking Normally Open Current Sinking Normally Closed Current Sourcing Normally Open Current Sourcing All types Sink or Source max of 50 mA
Repeatability	Limits: ±10 microns (unidirectional) Home: See Z channel specifications

Hall Effect Specifications

Description	Specification
Input Power	+5 to +24 VDC, 30 mA
Output	Open Collector, Current Sinking, 20 mA Max





Cable Transport Module

The LXR's Cable Transport Module offers the convenience of "plug and play" connectivity for fast, easy table installation and "quick change" replacement. This system of cable management includes the highest quality high-flex ribbon cable with a life rating of 30 million cycles, a cable track with support brackets, a "quick change" carriage cartridge, and a plug-in connector panel housing. It also provides a "pass-through" connection and cabling for customer application. This transport module option is ideal for high throughput continuous duty requirements where downtime is not acceptable.



"Quick Change" Cartridge



Cable Extensions - Flying Leads Terminations



404LXR Cable Transport Module

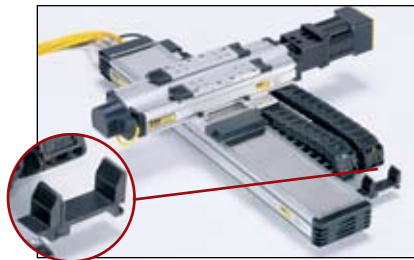

2-Axis System w/Expandable Cable Management



404LXR

406LXR/412LXR

Cable Transport Module Order Code

Order Code	Extension Cable	
	Length (m)	Termination
CM02	No Extension Cables	
CM07	3.0	Flying Leads
CM08	7.5	Flying Leads
CM09	3.0	Gemini Conn.
CM10	7.5	Gemini Conn.
CM13	3.0	Aries/VIX Conn.
CM14	7.5	Aries/VIX Conn.

OEM Cable System

The LXR's unharnessed cable system is offered for OEMs and others who have independent methods of routing and managing cables. These systems offer the "quick change" cartridge, "pass-through" connection and round high-flex cables in lengths of 3.0 or 7.5 meters. They are available with flying lead end terminations, as well as Gemini or Aries connectors.



406LXR with OEM cables and flying leads

OEM Cable System Order Code

Order Code	Extension Cable	
	Length (m)	Termination
CM03	3.0	Flying Leads
CM04	7.5	Flying Leads
CM05	3.0	Gemini Conn.
CM06	7.5	Gemini Conn.
CM11	3.0	Aries/VIX Conn.
CM12	7.5	Aries/VIX Conn.

User "Pass-Through" Cabling

Cable concerns regarding routing and durability for payload or instrument signals are addressed by the pass-through connectivity feature included with both of the LXR cable management systems. Nine pin D-connectors provided on the carriage (with the transport module units) and the cable connecting block combine with high-flex, long life cables for easy setup and dependable performance.

Note: Extension cables are available and can be ordered separately - 006-1743-01 (3 meters); 006-1743-02 (7.5 meters).

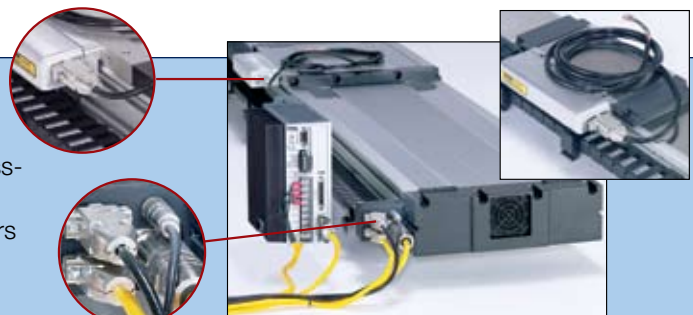

- Pre-wired plug-in connection to the moving payload
- Nine user conductors for end-effectors or instruments
- High-flex long life cables:
 - Ribbon Cable - Transport Module System
 - Round Cable - OEM System

Simple Configuration Digital Drive Options

All digital drives ordered in the LXR part number configuration come set up with a motor file including electrical parameters to set continuous and peak currents, current loop compensation values, and default gain settings. Users will have the ability to override these parameters for special application requirements. Tuning is easy to use and intuitive for users and is available via a variety of methods. The motor and loading information must be known by the drive to determine the baseline tuning gains. These are simple parameter entries the user can complete with the help of standard Parker supplied front-end software tools.

Aries Series



Aries Digital Drive

The Aries option allows the user to select the fully digital compact servo drive from Parker. Look for upcoming additions to the LXR configured with the Aries ETHERNET Powerlink version as well as the Aries Drive/Controller versions.

Order Codes: A62 A63

Gemini Series



GV Digital Servo Drive

The Gemini Series offers a fully digital servo drive configured directly in the LXR part numbering system.

Order Codes: A4 A7 A40

GV Digital Controller/Servo Drive

The Gemini Series servo drive/controller option allows the user to order a preconfigured digital drive/controller for a single-axis easy to use solution.

Order Codes: A5 A6 A8 A9 A41 A42

For complete details on drive product features and specifications, please refer to the "Drives & Controllers" section of this catalog.

Dowel Pinning Options

Order Codes: P1 P2 P3

Standard dowel pin locating holes P1 are offered on all 400LXR units to facilitate repeatable mounting of tooling or payload.

In addition, pinning options P2 and P3 are offered for precise orthogonal mounting of the second axis in a multi-axis system. In this case, the bottom side of the table base is match drilled and reamed to the first axis to provide exact orthogonal location. This convenient option eliminates concerns regarding contamination or damage often associated with machining for locating pins in an assembled unit. In some instances a 404LXR pinning adapter may be required part number 100-9584-01.



Two locating dowel holes, right (P1 option) shown in 404LXR carriage



Cleanroom Preparation Option

Order Codes: R2

Cleanroom compatible linear tables are often required for laboratory and production applications in industries such as semiconductor, life science, electronics, and pharmaceuticals.

400LXR tables with cleanroom preparation were tested in Parker's vertical laminar flow work station, which utilizes ULPA filters to produce an environment having a cleanliness of class 1 prior to testing. Tables were tested in a variety of orientations with sampling both below the table and at the carriage mounting surface. Laminar flow rate is 0.65 inches W.C.

Special cleanroom testing can be provided upon request. For more information on cleanroom testing, contact a Parker Applications Engineer at 800-245-6903.



404LXR with cleanroom Class 10 modification

About Cleanrooms

A room in which the concentration of airborne particles is controlled within defined limits. Federal Standard 209E statistically defines the allowable number of particles per cubic foot of air.

The chart below describes the conditions that must be maintained for the cleanroom to have a specific "class" rating.

Class	Number of Allowable Particles (Measured particle size in microns μm)				
	0.1	0.2	0.3	0.5	5
1	35	7.5	3	1	0
10	350	75	30	10	0
100	—	750	300	100	0
1000	—	—	—	1000	7
10000	—	—	—	10000	70
100000	—	—	—	100000	700

Standard Cleanroom Preparation

- Stringent cleaning and handling measures
- Cleanroom rated lubrication
- Strip seal replaced with hard shell cover



Testing at 4.5 inches below table

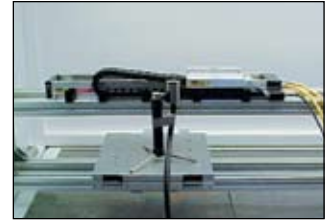

Testing at carriage mounting surface

400LXR Cleanroom Compatibility

Table Velocity	Class	
	4.5" Below Table	At Carriage Surface
250 mm/sec	10	1
500 mm/sec	25	1
1000 mm/sec	50	5
2000 mm/sec	250	25
3000 mm/sec	500	100

Toe Clamp Accessories

Part Number: 100-8376-01 (404LXR)
002-3624-01 (406LXR)
002-2160-01 (412LXR)

Toe clamps for mounting 400LXR tables are ordered separately.

Note that 400LXR Series toe clamps are not interchangeable with toe clamps for 400XR Series tables.



Dimensions (mm)

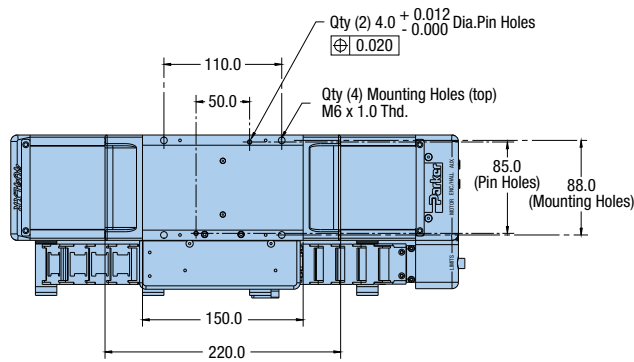

Top View
(With Cable Transport Module)

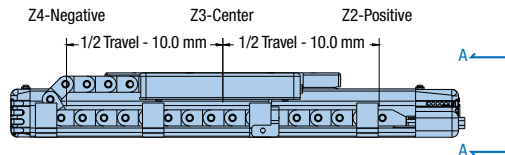

Front View
Z-Channel Location

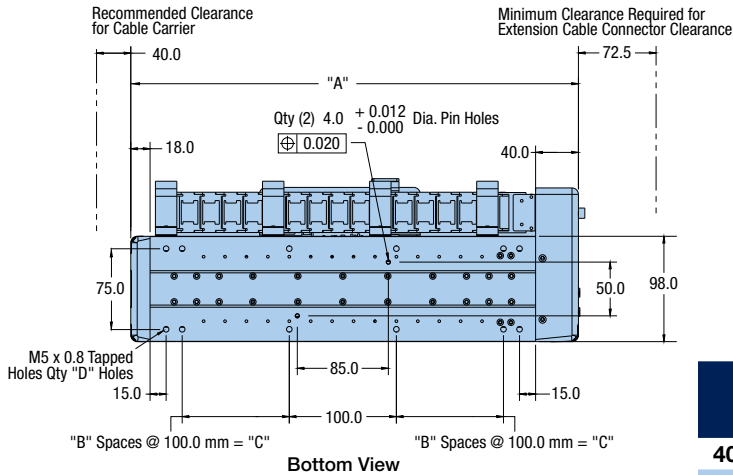

Bottom View

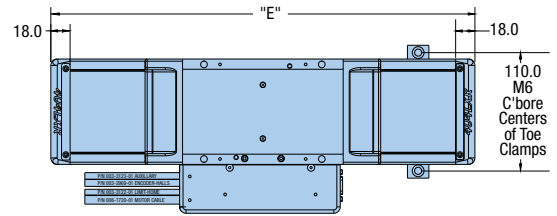

OEM Cables (Strip Seal/Hardcover)

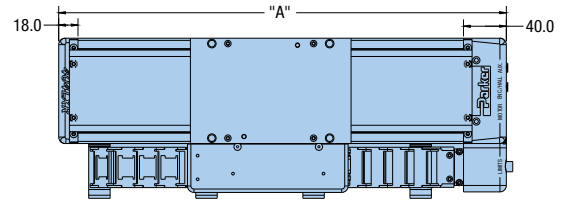

Cable Module (Strip Seal/Hardcover)

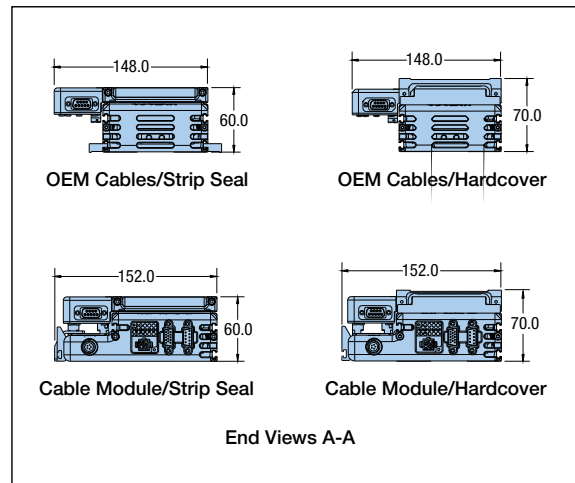

End Views A-A

Model	Travel (mm)	Dimensions (mm)				
		A	B	C	D	E
404T00LXR	50	368.0	1	100.0	12	346.0
404T01LXR	100	418.0	1	100.0	12	396.0
404T02LXR	150	468.0	1	100.0	12	446.0
404T03LXR	200	518.0	1	100.0	12	496.0
404T04LXR	250	568.0	1	100.0	12	546.0
404T05LXR	300	618.0	2	200.0	16	596.0
404T06LXR	350	668.0	2	200.0	16	646.0
404T07LXR	400	718.0	2	200.0	16	696.0
404T09LXR	500	818.0	3	300.0	20	796.0
404T11LXR	600	918.0	3	300.0	20	896.0
404T13LXR	700	1018.0	4	400.0	24	996.0
404T15LXR	800	1118.0	4	400.0	24	1096.0
404T17LXR	900	1218.0	5	500.0	28	1196.0
404T19LXR	1000	1318.0	5	500.0	28	1296.0



Fill in an order code from each of the numbered fields to create a complete model order code.

① ② ③ ④ ⑤ ⑥ ⑦ ⑧ ⑨ ⑩ ⑪ ⑫ ⑬ ⑭

Order Example: 404 T04 LXR M P D13 H3 L2 CM09 Z2 E2 R1 A4 P1

- ① **Series**
404
- ② **Travel – mm**
8 Pole Motor
T00 50
T01 100
T02 150
T03 200
T04 250
T05 300
T06 350
T07 400
T09 500
T11 600
T13 700
T15 800
T17 900
T19 1000
- ③ **Model**
LXR Linear Motor
- ④ **Mounting**
M Metric
- ⑤ **Grade**
P Precision
- ⑥ **Drive Type**
D3 Free Travel (No Motor)
D13 8 Pole Motor
- ⑦ **Home Sensor**
H1 None-Free Travel (only)
H2 N.C. Current Sinking
H3 N.O. Current Sinking
H4 N.C. Current Sourcing
H5 N.O. Current Sourcing
- ⑧ **Limit Sensor**
L1 None-Free Travel (only)
L2 N.C. Current Sinking
L3 N.O. Current Sinking
L4 N.C. Current Sourcing
L5 N.O. Current Sourcing
- ⑨ **Cable Management**
CM01 No Cables – Free Travel
CM02 Cable Transport Module (only)
CM03 3.0 m OEM Cable Set-FL
CM04 7.5 m OEM Cable Set-FL
CM05 3.0 m OEM Cable Set-Gemini
CM06 7.5 m OEM Cable Set-Gemini
CM07 Cable Trans Mod. w/3.0 m-FL*
CM08 Cable Trans Mod. w/7.5 m-FL*
CM09 Cable Trans Mod. w/3.0 m-Gemini*
CM10 Cable Trans Mod. w/7.5 m-Gemini*
CM11 3.0 m OEM Cable Set-Aries/ViX
CM12 7.5 m OEM Cable Set-Aries/ViX
CM13 Cable Trans Mod. w/3.0 m-Aries/ViX*
CM14 Cable Trans Mod. w/7.5 m-Aries/ViX*
* Extension cable for pass through connection is available and can be ordered separately: #006-1743-01 (3 meters); #006-1743-02 (7.5 meters)
- ⑩ **Z Channel Location***
Z1 None
Z2 Positive End Position
Z3 Center Position
Z4 Negative End Position
* Refer to dimensions on previous page
- ⑪ **Encoder Option**
E1 None
E2 1.0 µm Resolution
E3 0.5 µm Resolution
E4 0.1 µm Resolution
E5 5.0 µm Resolution
E7 Sine Output Encoder
- ⑫ **Environmental**
R1 Strip Seal
R2 Hard Cover w/Class 10 Cleanroom Prep
R3 Hard Cover without Cleanroom Prep
- ⑬ **Digital Drive**
A1 No Drive
A4 Gemini Drive GV-U6E
A5 Gemini Controller/Drive GV6-U6E
A6 Gemini Controller/Drive GV6K-U6E
A62 Aries Drive AR-04AE
- ⑭ **Pinning Option**
P1 No multi-axis pinning
P2 * X axis transfer pinning to Y or Z axis - 30 arc-sec
P3 * Y axis transfer pinning to X axis - 30 arc-sec
* Transfer pinning to XR from LXR requires additional bracket and an EPS request. Call 1-800-245-6903 for details.

Linear Motor Driven Tables



8 or 12 Pole Slotless Motor

Dimensions (mm)

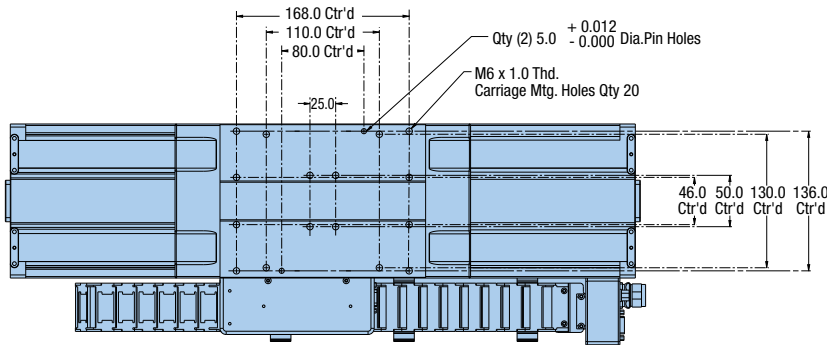

Top View
(with Cable Transport Module)

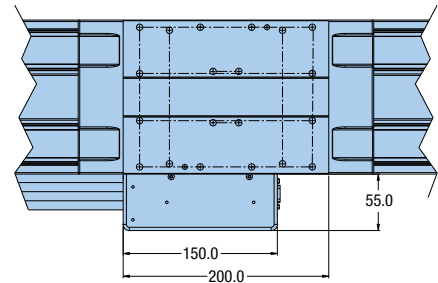

Top View
(with OEM Cable System)

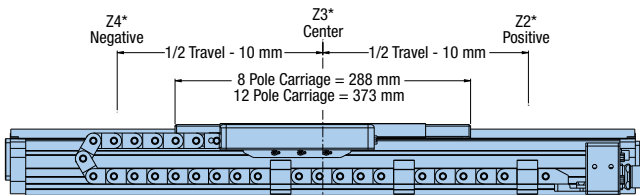

Front View
(Z-Channel Location)

*Z2, Z3, Z4 shows Carriage Center-line Location for Selected Z-Channel Position

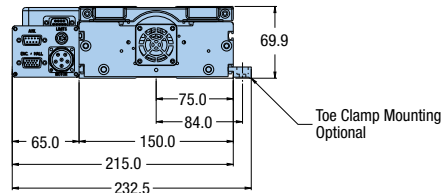

End View
(with OEM Cable System)

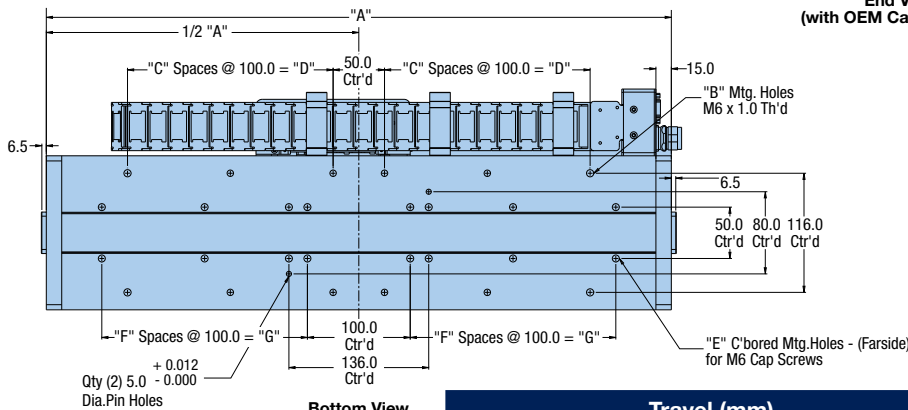

Bottom View

Model	Travel (mm)		Dimensions (mm)						
	8 Pole	12 Pole	A	B	C	D	E	F	G
406T01LXR	50	—	408	8	1	100.0	12	1	100.0
406T02LXR	150	50	508	8	1	100.0	12	1	100.0
406T03LXR	250	150	608	12	2	200.0	16	2	200.0
406T04LXR	350	250	708	12	2	200.0	16	2	200.0
406T05LXR	450	350	808	16	3	300.0	20	3	300.0
406T06LXR	550	450	908	16	3	300.0	20	3	300.0
406T07LXR	650	550	1008	20	4	400.0	24	4	400.0
406T08LXR	750	650	1108	20	4	400.0	24	4	400.0
406T09LXR	850	750	1208	24	5	500.0	28	5	500.0
406T10LXR	950	850	1308	24	5	500.0	28	5	500.0
406T11LXR	1200	1100	1558	32	7	700.0	32	6	600.0
406T12LXR	1450	1350	1808	36	8	800.0	40	8	800.0
406T13LXR	1700	1600	2058	40	9	900.0	44	9	900.0
406T14LXR	1950	1850	2308	44	10	1000.0	48	10	1000.0



Fill in an order code from each of the numbered fields to create a complete model order code.

	①	②	③	④	⑤	⑥	⑦	⑧	⑨	⑩	⑪	⑫	⑬	⑭
Order Example:	406	T08	LXR	M	P	D13	H2	L2	CM09	Z2	E2	R1	A4	P1

- ① **Series**
406
- ② **Travel – mm**

	8 Pole Motor	12 Pole Motor
T01	50	—
T02	150	50
T03	250	150
T04	350	250
T05	450	350
T06	550	450
T07	650	550
T08	750	650
T09	850	750
T10	950	850
T11	1200	1100
T12	1450	1350
T13	1700	1650
T14	1950	1850
- ③ **Model**
LXR Linear Motor
- ④ **Mounting**
M Metric
- ⑤ **Grade**
P Precision
- ⑥ **Drive Type**
 - Free Travel (No Motor)
 - D3 8 Pole Motor (No Motor)
 - D5 12 Pole Motor (No Motor)
 - Linear Motor
 - D13 8 Pole Motor Carriage
 - D15 12 Pole Motor Carriage
- ⑦ **Home Sensor**
 - H1 None-Free Travel (only)
 - H2 N.C. Current Sinking
 - H3 N.O. Current Sinking
 - H4 N.C. Current Sourcing
 - H5 N.O. Current Sourcing
- ⑧ **Limit Sensor**
 - L1 None-Free Travel (only)
 - L2 N.C. Current Sinking
 - L3 N.O. Current Sinking
 - L4 N.C. Current Sourcing
 - L5 N.O. Current Sourcing
- ⑨ **Cable Management**
 - CM01 No Cables – Free Travel
 - CM02 Cable Transport Module (only)
 - CM03 3.0 m OEM Cable Set-FL
 - CM04 7.5 m OEM Cable Set-FL
 - CM05 3.0 m OEM Cable Set-Gemini
 - CM06 7.5 m OEM Cable Set-Gemini
 - CM07 Cable Trans Mod. w/3.0 m-FL*
 - CM08 Cable Trans Mod. w/7.5 m-FL*
 - CM09 Cable Trans Mod. w/3.0 m-Gemini*
 - CM10 Cable Trans Mod. w/7.5 m-Gemini*
 - CM11 3.0 m OEM Cable Set-Aries/ViX
 - CM12 7.5 m OEM Cable Set-Aries/ViX
 - CM13 Cable Trans Mod. w/3.0 m-Aries/ViX*
 - CM14 Cable Trans Mod. w/7.5 m-Aries/ViX*

* Extension cable for pass through connection is available and can be ordered separately: #006-1743-01 (3 meters); #006-1743-02 (7.5 meters)
- ⑩ **Z Channel Location***
 - Z1 None
 - Z2 Positive End Position
 - Z3 Center Position
 - Z4 Negative End Position

* Refer to dimensions on previous page
- ⑪ **Encoder Option**
 - E1 None
 - E2 1.0 μm Resolution
 - E3 0.5 μm Resolution
 - E4 0.1 μm Resolution
 - E5 5.0 μm Resolution
 - E7 Sine Output Encoder
- ⑫ **Environmental**
 - R1 Strip Seal
 - R2 Hard Cover w/Class 10 Cleanroom Prep
- ⑬ **Digital Drive**
 - A1 No Drive
 - A4 Gemini Drive GV-U6E
 - A5 Gemini Controller/Drive GV6-U6E
 - A6 Gemini Controller/Drive GV6K-U6E
 - A62 Aries Drive AR-04AE
- ⑭ **Pinning Option**
 - P1 No multi-axis pinning
 - P2 * X axis transfer pinning to Y or Z axis - 30 arc-sec
 - P3 * Y axis transfer pinning to X axis - 30 arc-sec

* Transfer pinning to XR from LXR requires additional bracket and an EPS request. Call 1-800-245-6903 for details.



12 Pole Slotless Motor

Dimensions (mm)

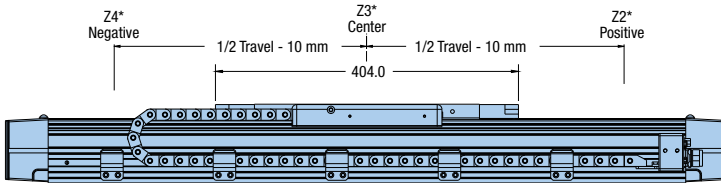
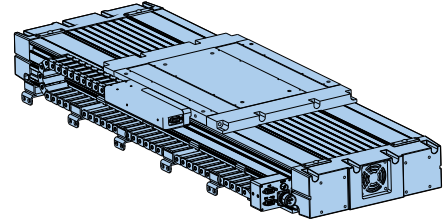
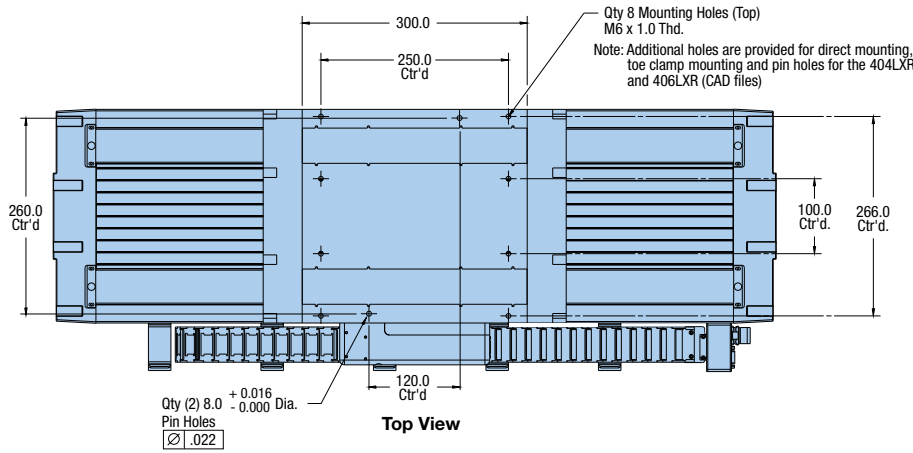

*Z2, Z3, Z4 shows Carriage Center-line Location for Selected Z-Channel Position

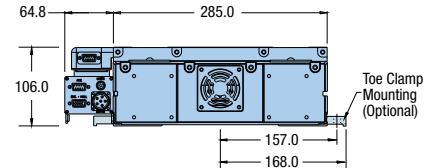

End View

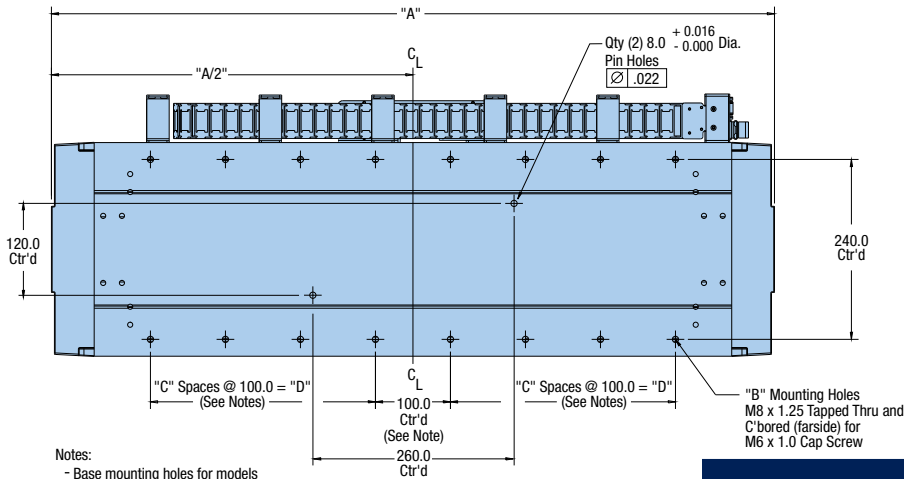

Notes:
- Base mounting holes for models 412T10 and 412T12 are patterned from one hole on centerline

Bottom View

Model	Travel (mm)	Dimensions (mm)			
		A	B	C	D
412T01LXR	150	764	12	2	200
412T02LXR	250	864	16	3	300
412T03LXR	350	964	16	3	300
412T04LXR	650	1264	24	5	500
412T05LXR	800	1414	24	5	500
412T06LXR	1000	1614	28	6	600
412T07LXR	1200	1814	32	7	700
412T08LXR	1500	2114	40	9	900
412T09LXR	1750	2364	44	10	1000
412T10LXR	2000	2614	50	12	1200
412T11LXR	2500	3114	60	14	1400
412T12LXR	3000	3614	70	17	1700



Fill in an order code from each of the numbered fields to create a complete model order code.

- ① ② ③ ④ ⑤ ⑥ ⑦ ⑧ ⑨ ⑩ ⑪ ⑫ ⑬ ⑭

Order Example: 412 T09 LXR M P D15 H3 L3 CM09 Z2 E2 R1 A7 P1

- ① **Series**
412
- ② **Travel – mm**
8 Pole Motor
T01 150
T02 250
T03 350
T04 650
T05 800
T06 1000
T07 1200
T08 1500
T09 1750
T10 2000
T11 2500
T12 3000
- ③ **Model**
LXR Linear Motor
- ④ **Mounting**
M Metric
- ⑤ **Grade**
P Precision
- ⑥ **Drive Type**
D5 Free Travel (No Motor)
D15 12 Pole Motor
- ⑦ **Home Sensor**
H1 None-Free Travel (only)
H2 N.C. Current Sinking
H3 N.O. Current Sinking
H4 N.C. Current Sourcing
H5 N.O. Current Sourcing
- ⑧ **Limit Sensor**
L1 None-Free Travel (only)
L2 N.C. Current Sinking
L3 N.O. Current Sinking
L4 N.C. Current Sourcing
L5 N.O. Current Sourcing
- ⑨ **Cable Management**
CM01 No Cables – Free Travel
CM02 Cable Transport Module (only)
CM03 3.0 m OEM Cable Set-FL
CM04 7.5 m OEM Cable Set-FL
CM05 3.0 m OEM Cable Set-Gemini
CM06 7.5 m OEM Cable Set-Gemini
CM07 Cable Trans Mod. w/3.0 m-FL*
CM08 Cable Trans Mod. w/7.5 m-FL*
CM09 Cable Trans Mod. w/3.0 m-Gemini*
CM10 Cable Trans Mod. w/7.5 m-Gemini*
CM11 3.0 m OEM Cable Set-Aries/ViX
CM12 7.5 m OEM Cable Set-Aries/ViX
CM13 Cable Trans Mod. w/3.0 m-Aries/ViX*
CM14 Cable Trans Mod. w/7.5 m-Aries/ViX*
* Extension cable for pass through connection is available and can be ordered separately: #006-1743-01 (3 meters); #006-1743-02 (7.5 meters)
- ⑩ **Z Channel Location***
Z1 None
Z2 Positive End Position
Z3 Center Position
Z4 Negative End Position
* Refer to dimensions on previous page
- ⑪ **Encoder Option**
E1 None
E2 1.0 µm Resolution
E3 0.5 µm Resolution
E4 0.1 µm Resolution
E5 5.0 µm Resolution
E7 Sine Output Encoder
- ⑫ **Environmental**
R1 Strip Seal
R2 Hard Cover w/Class 10 Cleanroom Prep
- ⑬ **Digital Drive**
A1 No Drive
A7 Gemini Drive GV-U6E
A8 Gemini Controller/Drive GV6-U6E
A9 Gemini Controller/Drive GV6K-U6E
A63 Aries Drive AR-04AE
- ⑭ **Pinning Option**
P1 No multi-axis pinning
P2 * X axis transfer pinning to Y or Z axis - 30 arc-sec
P3 * Y axis transfer pinning to X axis - 30 arc-sec
* Transfer pinning to XR from LXR requires additional bracket and an EPS request. Call 1-800-245-6903 for details.

Trilogy I-Force Ironless Linear Motors

www.parker.com/em/ironless



Parker Trilogy's I-Force ironless motors offer high force and rapid accelerations in a compact package. Parker Trilogy's patented I-beam shape, with its overlapping windings, allows for a higher power density in a smaller motor, improved heat removal, and added structural stiffness. A forgiving air gap and no attractive forces allow for easy installation and zero cogging during motion.

- 5 different cross sections (110, 210, 310, 410, and ML50) up to 8 poles
- Compact size with high force density and superior heat removal
- Air and water cooling
- Vacuum rated to 10⁻⁶ torr
- Ultra high-flex cable standard

Trilogy RIPPED Ironcore Linear Motors

www.parker.com/em/ironcore



Parker Trilogy's RIPPED ironcore linear motors, with their patent-pending anti-cog technology, can produce the large forces needed for many industrial applications – without the roughness associated with traditional ironcore linear motors. The RIPPED family is well suited for a broad range of extremely demanding applications.

- Patent-pending anti-cog technology for extremely smooth motion
- 5 different cross sections
- Single magnet row for high performance at an economical price
- Connector module allows for quick installation and easy cable management
- Ultra high-flex cable standard

Trilogy ML50 Ironless Linear Motors

www.parker.com/em/ML50



Parker Trilogy's ML50 ironless linear motors are optimized to provide high forces with minimum moving mass, making them the ideal choice for applications requiring very

high, continuous accelerations of relatively light payloads. Demanding applications such as high-speed pick and place, die sorting, injection mold loading/unloading, and textile weaving can all benefit from unique characteristics of the ML50 motors.

- Optimized for ultra high acceleration of light payloads
- Compact size with high force density and superior heat removal
- Connector module for quick installation and easy cable management
- Ultra high-flex cable standard

Series	I-Force Ironless	ML50 Ironless	Ripped Ironcore
Continuous force	5.5 to 197.5 lbf (24.5 to 878.6 N)	43 to 192 lbf (189 to 852 N)	13 to 501 lbf (56 to 2230 N)
Peak force	45.5 to 883 lbf (202.5 to 3928 N)	190 to 857 lbf (847 to 3811 N)	43 to 1671 lbf (190 to 7433 N)
Cogging force	Zero	Zero	Low
Attractive force	Zero	Zero	High
Magnet tracks	Dual	Dual	Single
Heat dissipation	Good	Good	Better
Applications	Rapid accelerations, extremely smooth motion	Ultra high accelerations of relatively light payloads	High force, lower cost for long travels





Trilogy Ironless and Ironcore Linear Motor Positioning Tables

www.parker.com/em/lmpositioners

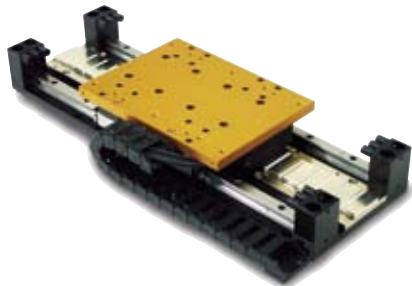

Parker linear positioners utilize our high-performance Trilogy ironless and ironcore linear motors in a pre-engineered, easily integrated, ready-to-run package. The principal design goal for these positioners is to achieve high performance at an economical cost while preserving the design flexibility to accommodate customization. Options include multi-axis configurations, bellows, and a variety of cable management systems.

- Single- or dual-bearing rail positioners to better match the performance and cost requirements for each application
- Magnetic encoders for industrial environments or optical encoders with resolutions down to 0.1 micron
- Multiple carriage options
- Open frame, bellows or two covers available
- Zero cogging (ironless) or extremely smooth (ironcore)
- Counterbalance options for vertical applications
- Velocities to 7 m/s



Linear Motor Driven Tables

For more information on these Trilogy products, refer to our complete Linear Motor Catalog #96-028778-01.

Series	T1S / T1D	T2S / T2D	T3S / T3D	T4S / T4D	TR7	TR9	TR16
Motor	110 ironless	210 ironless	310 ironless	410 ironless	R7 ironcore	R9 ironcore	R16 ironcore
Travel lengths (mm)	100 to 900	60 to 3840	60 to 4390	78 to 3835	105 to 2745	108 to 3708	94 to 3694
Load (kg)	11.3*/13.5**	27.2*/45.3**	72*/108**	90*/181**	200**	300**	450**
Acceleration (G's) ***	5	5	5	5	5	5	5
Velocity (m/s) †	up to 3	up to 5	up to 5	up to 5	up to 5	up to 5	up to 5
Peak force (N)	202.5	494.2	1170.0	3928.1	1761.0	4097.0	7433.0
Continuous force (N)	45.4	110.3	262.0	878.6	462.0	1121.0	2230.0
Resolution (micron)	0.1 to 5.0	0.1 to 5.0	0.1 to 5.0	0.1 to 5.0	0.1 to 5.0	0.1 to 5.0	0.1 to 5.0
Repeatability (micron) ‡	±1	±1	±1	±1	±1	±1	±1

* Single rail load specifications

** Dual rail load specifications

*** Consult factory for higher accelerations

† Peak velocity is encoder dependent

‡ Repeatability is resolution dependent

Recommended loads based on motor size and typical performance.

Bearing specifications exceeded listed specifications. Consult factory for higher loads.

RD Direct Drive Rotary Stages

www.parkermotion.com/products



Parker Direct Drive Rotary Stages feature a robust construction and high performance in a compact package, providing smooth, near frictionless motion with zero backlash.

Featuring an integral brushless DC servo motor, these rotary stages offer several distinct advantages over traditional worm gear-driven stages. The elimination of the worm gearing offers the ability to reduce wear with zero backlash while exhibiting near frictionless motion.

Its high positioning accuracy, solely based on the stage's encoder, provides repeatability within 2 encoder counts, with resolutions ranging to 1.4 arc-seconds. The RD Direct Drive features speeds up to 700 RPM with significant torque capability.

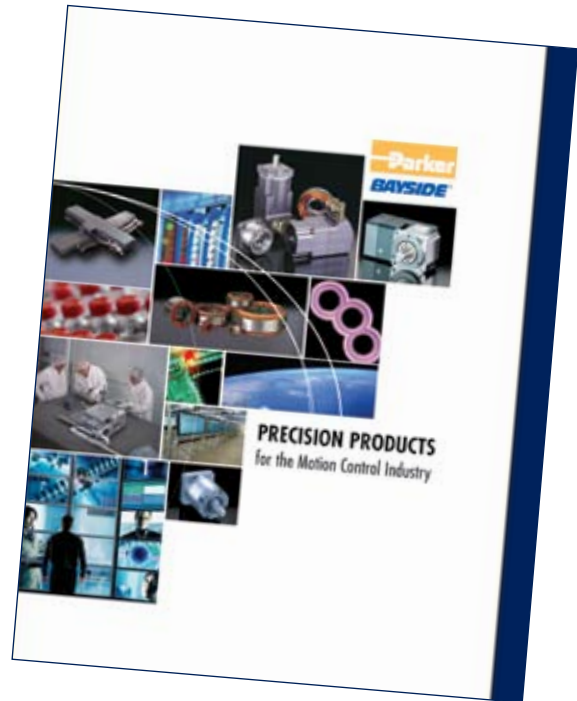

For more information on Parker's direct drive rotary products, please refer to catalog 8100.

Applications

- Electronic assembly
- Fiber Optics
- Medical
- Packaging
- Pharmaceutical

Recommended Uses

- Precision rotary motion
- ZERO backlash
- Compact
- Rugged

Unique design integrated brushless motor features high copper slot and rare earth magnet for maximum torque efficiency

Aluminum or stainless steel precision ground top plate for accurate mounting

Robust bearing design for high load capacity

Sub "D" connectors for "plug & play" operation and easy hook-up.

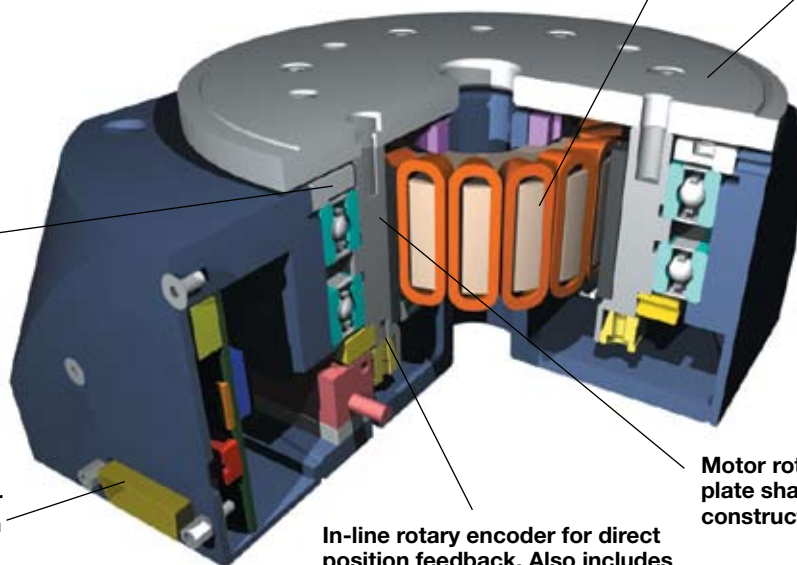

In-line rotary encoder for direct position feedback. Also includes once per rev index mark

Motor rotor and top plate shaft as one-piece construction for high stiffness

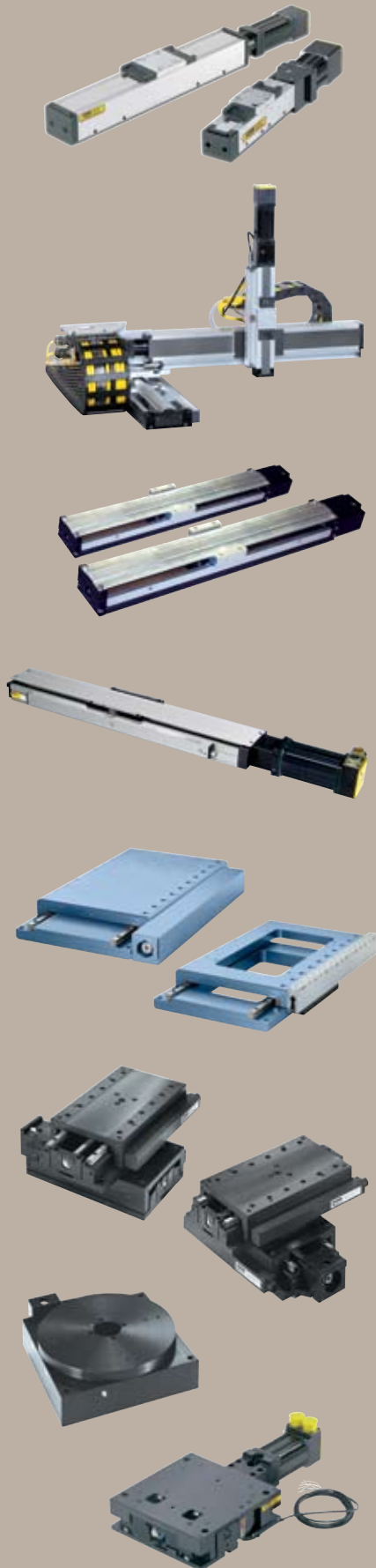

Screw Driven automation tables

Precise multi-axis positioning systems play an integral part in today's semiconductor, computer peripheral, solar power, flat panel, life sciences, lab automation, biomedical and electronics industries. The demands for tighter specifications, improved throughput and consistent quality have become increasingly stringent. Because of the complexity associated with these systems, many manufacturers insist on a single source supplier to eliminate multiple vendor design incompatibilities and delivery conflicts. With over forty years' experience as a global leader in the development of products and technology, Parker provides the most advanced, easy to integrate high-precision electromechanical systems.

Contents

30-33	Overview
34-63	400XR Series Precision Linear Positioners
64-69	XRS Cartesian Systems
70-79	402/403XE Series Positioners
80-89	404XE Series Positioners
90-111	HD Series Industrial Linear Positioners
112-127	Ultra Series Precision Stages
128-133	100CT & 800CT Series Tables
134-137	200RT Series Rotary Tables
138-141	R Series Worm Drive Rotary Tables
142-145	ZP200 Series Vertical Lift "Wedge" Table
146-150	Additional Products

Parker High-precision Systems and Services include:

- Selectable Levels of Integration™ that let you pick the product or system which suits your need and fits your capability
- The most comprehensive array of products in the industry
- Advanced product development
- Seamless integration with other Parker components including servo motors, motor drives, controls, interfaces, actuators, pneumatics, and structural components
- Modular construction from standard catalog tables or custom systems designed and built to specification
- Global Parker support network (1-800-C-PARKER)

Product Comparisons: Parker high-precision screw driven tables are divided into families (or groups) which are distinguished by the primary bearing style and precision. All tables are offered with several drive mechanism options and are designed for direct connection to standard frame size stepper or servo motors. Each family is shown here for a quick comparison based on key parameters.

- Easy, multi-axis connectivity
- Submicron precision
- Velocities up to 1.5 meters/second
- Cleanroom and vacuum compatible
- Thorough testing and certification



400XR Series Precision Linear Positioners

Page 34-63



The key attributes of the XR Series Positioners are high strength, long travel range, and high precision utilizing square rail technology. These tables can satisfy the vast majority of high-precision positioning applications in high-technology markets.

- Travel Range: 2000 mm
- Load Capacity: 1470 kg
- Maximum Speed: 1.5 meters/sec
- Duty Cycle: 100%
- Repeatability: ±1.3 µm (bidirectional)

XRS Cartesian Systems

Page 64-69



Utilizing our standard and precision XR series positioning tables, Parker has developed the XRS family of Cartesian systems. These systems offer broad range of scalability, a unique mix of technology, and a rugged long lasting product.

- Travel Range: 300 x 300 mm to 1000 x 600 x 150 mm
- Load Capacity: 25 kg
- Maximum Speed: 2 m/s on one axis
- Duty Cycle: 100%
- Repeatability: ±6 to ±50 micron per axis

402/403XE Series Ballscrew Positioners

Page 70-79



The steel base constructed 402/403XE series offers rigid compact positioning for the cost conscious motion applications. A highly integrated ballscrew, bearing retainer system results in a very low overall height and high payload capacities.

- Travel Range: 655 mm
- Load Capacity: 160 kg
- Maximum Speed: 0.8 m/s
- Duty Cycle: 100%
- Repeatability: $\pm 5 \mu\text{m}$

HD Series Industrial Linear Positioners

Page 90-111



By incorporating a deep channel design, coupled with a belt seal and industrial grade ballscrews, the HD series offers an economical solution for industrial positioning. Perfect for use in many industries from packaging to liquid dispensing, the HD series is a robust, rigid, industrial grade positioner, without the precision of the XR, for a lower cost.

- Travel Range: 2 m
- Load Capacity: 1470 kg
- Maximum Speed: 1.5 m/s
- Duty Cycle: 100%
- Repeatability: $\pm 8 \mu\text{m}$

404XE Series Series Ballscrew Positioners

Page 80-89



The 404XE is an economy version of the 404XR. This product is ideal for applications where the precision of the XR is not needed, but the wide flat stance of the XR family benefits the application details.

- Travel Range: 700 mm
- Load Capacity: 125 kg
- Maximum Speed: 1.4 m/s
- Duty Cycle: 100%
- Repeatability: $\pm 30 \mu\text{m}$

Ultra Series Precision Stages

Page 112-127

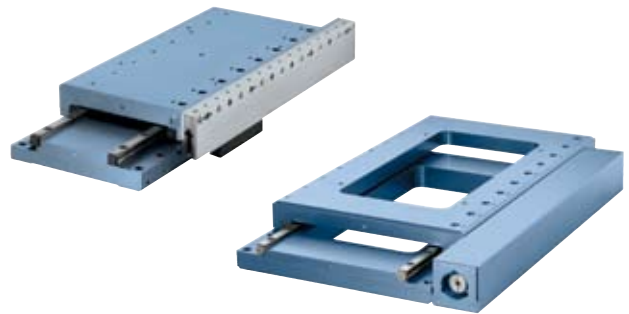

The Ultra Series features precision cross roller bearings, an optional open frame design, and lead screw, ballscrew, or linear motor drive options.

- Travel Range: 0.5 m
- Load Capacity: 2187 kg
- Maximum Speed: 1.5 m/s
- Duty Cycle: 100%
- Repeatability: $\pm 0.5 \mu\text{m}$

Screw Driven
Tables

100CT & 800CT Series Ballscrew Positioners

Page 128-133

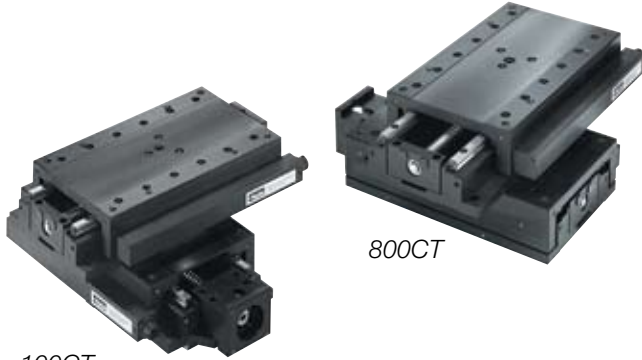

100CT

800CT

These tables offer ultra-smooth highly precise motion and positioning. They are much stronger – providing higher load carrying capability and offer a 100% duty cycle.

Travel Range: 300 mm
 Load Capacity: 400 pounds
 Maximum Speed: 250 mm/sec
 Duty Cycle: 100%
 Repeatability: $\pm 1.3 \mu\text{m}$ (bidirectional)

200RT Series Rotary Tables

Page 134-137

Rotary Tables provide continuous motor driven rotary

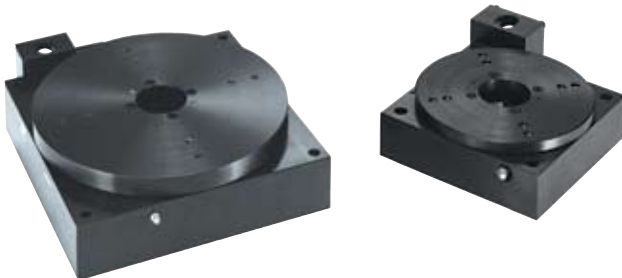

motion and precise positioning. They are offered in 5, 6, 8, 10, and 12 inch diameters. Their low profile and light weight make them ideal indexing units for multi-axis combination with high-precision linear tables.

Travel Range: continuous
 Load Capacity: 90 kg
 Maximum Speed: 150 deg/sec
 Duty Cycle: 50%
 Repeatability: 0.2 arc-min (unidirectional)

R Series Worm Drive Rotary Tables

Page 138-141



- Unique self-compensating preload to limit backlash
- Solid or thru bore construction
- Robust bearing design for high-load capacity
- Built-in limit switches
- Aluminum construction with stainless steel top plate

The Rotary Stage Series offers an unparalleled combination of high accuracy and high-load capacity. These rotary stages utilize a precision worm gear with the worm “flexed” against the gear to ensure a proper mesh. This feature provides high repeatability with very smooth operation. Additionally, the rotary stages incorporate an oversized preloaded cross roller bearing, offering exceptional stiffness and load capacity.

Travel Range: continuous
 Load Capacity: 600 kg
 Maximum Speed: 30 RPM
 Duty Cycle: 50%
 Repeatability: 12 arc-sec

ZP200 Vertical Lift “Wedge” Stages

Page 142-145



The ZP200 is a unique vertical lift stage providing up to 25 mm lift with no horizontal translation in a small package. The ZP200 uses ballscrew technology and a square rail bearing design.

Travel Range: 25 mm
 Load Capacity: 75 kg
 Maximum Speed: 0.4 m/s
 Duty Cycle: 100%
 Repeatability: $\pm 3 \mu\text{m}$

Additional Capabilities

Page 146-150

These pre-engineered tables are utilized primarily by OEMs for requirements which exceed Parker's standard catalog offering. They include high-precision square rail units, belt driven round rail units, heavy duty cross roller units, and high-speed rotary units.

An overview of these products is provided at the end of this section. Visit our website at www.parkermotion.com for complete specifications on these products, PDF data sheets and CAD drawing downloads.

Screw Driven
Tables

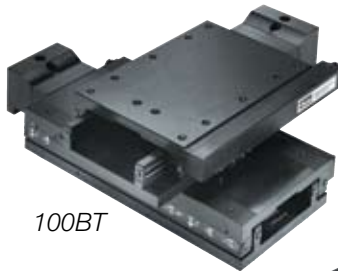

100BT



300AT

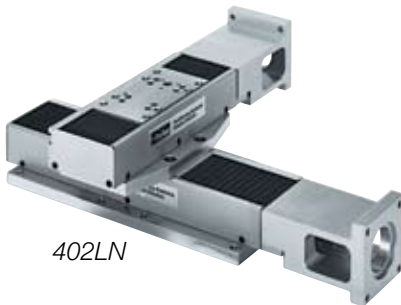

402LN



406LN



400ST



Motor Drives and Controls
(See pages 281-295)



506ET, 506ST

400XR Series Precision Linear Positioners

- Pre-engineered package
- Performance matched components
- Environmental protection
- Laser certified precision



Typical Enhancements

- Limit/home position sensors 412XR
- Linear encoder feedback
- Cleanroom preparation
- Multi-axis brackets & adapters
- Selectable motor mounts
- Servo motors and drives
- Programmable controls
- Cable management system

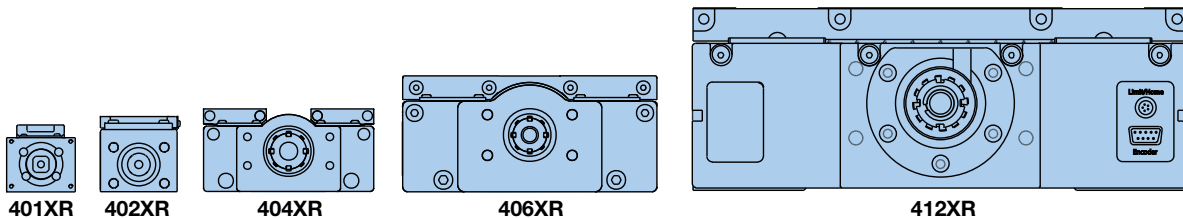

The “400XR” precision linear positioners family has achieved global recognition for consistent accuracy, reliable performance, high strength, and unmatched versatility. The XRs have excelled in industries such as life sciences, fiber optics and instrumentation, where the highest degree of precision is required. And yet, because of the rugged construction, strength, and sealed design, these units have been used extensively for industrial automation applications (packaging, automotive, etc).

The XR family offers an unrivaled array of features and options which are easily matched to fit any application, from the very basic to the highly complex. Premier performance, modular compatibility, and quick delivery have made these tables the perfect building blocks for precision multi-axis systems.

	401XR	402XR	404XR	406XR	412XR
Travel (mm)	300	600	600	2000	2000
Load (kg)	50	100	170	630	1470
Acceleration (m/sec²)	20	20	20	20	20

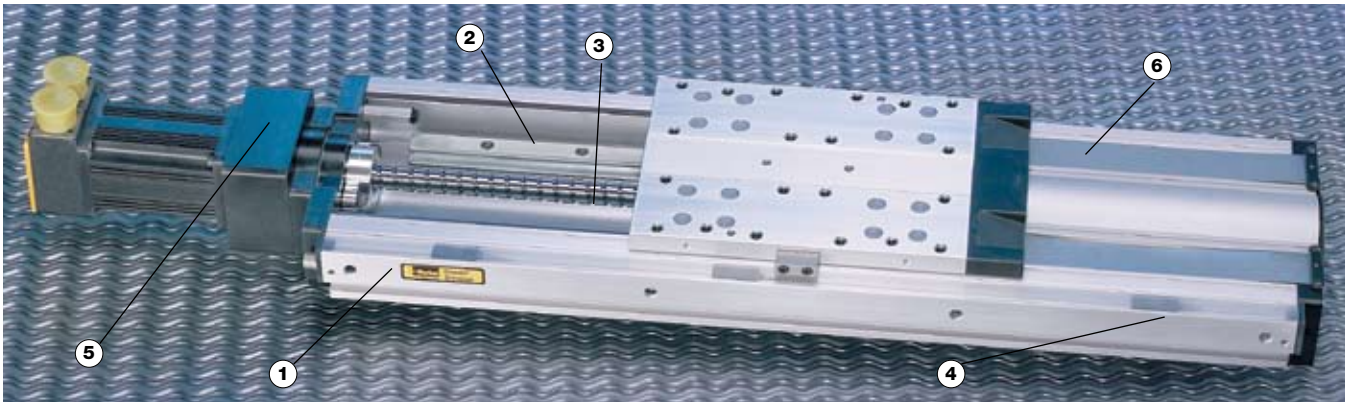

Screw Driven Tables

- 1 High Strength Aluminum Body**
Extruded aluminum housing is precision machined to provide outstanding straightness and flatness.
- 2 Square Rail Linear Bearing**
These tables are equipped with square rail carriage support bearings which provide high load carrying capabilities, smooth precise motion and dependable performance.
- 3 High Efficiency Ballscrew Drive**
Precision ground, or rolled ballscrew drive (5, 10, 20, 25, 32 mm lead) offers high throughput, efficiency, accuracy and repeatability.
- 4 Limit/Home Sensors**
Proximity sensors establish “end of travel” and “home” location and are easily adjustable over entire length to restrict the travel envelope.
- 5 Motor Mounts**
A large selection of servo and stepper motor sizes plus selectable mounting configurations (in-line, parallel) permit a wide variety of motor mounting possibilities.
- 6 IP30 Rated Strip Seals**
An anodized aluminum cover combined with stainless steel strip seals provide IP30 protection to interior components as well as enhance the overall appearance.

Encoders
The linear encoder option offers direct positional feedback of the carriage location. The rotary shaft encoder couples directly to the drive shaft to nullify any incurred mechanical error (particularly useful with the parallel motor mount). Not shown.

Shaft Brake
The electromagnetic shaft brake option couples directly to the drive screw and is employed primarily on vertical axes to halt carriage motion during a power loss. Not shown.

Convenient Mounting Slots
Continuous T-slots along the side of the table body provide a convenient means of mounting the table to a work surface as well as mounting accessories to the table.

Positive Pressure Port
A standard port (1/8 NPT) for pressurizing the interior to prevent particle intrusion. (Standard on 404XR, 406XR, 412XR units.)

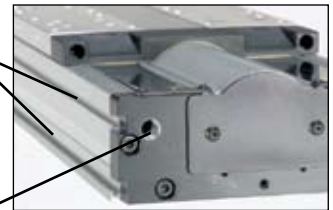

Easy Lube System
A standard option on some models, enables easy access for ballscrew and bearing lubrication.



Cleanroom Preparation
Class 10 cleanroom preparation is a standard option for the 400XR series. For detailed technical information on cleanroom preparation, contact Parker’s Application Engineering Department at **1.800.245.6903**

401XR (41 mm wide profile)

402XR Series (58 mm wide profile)

The 401XR and 402XR Series positioners enhance the 400XR family of precision linear positioners, addressing applications which involve precise positioning of smaller payloads within a very small space envelope.

These ballscrew driven positioners were developed to address the needs of industries such as photonics, life sciences, semiconductor, and instrumentation, where technology advancements dictate miniaturization of work envelopes.

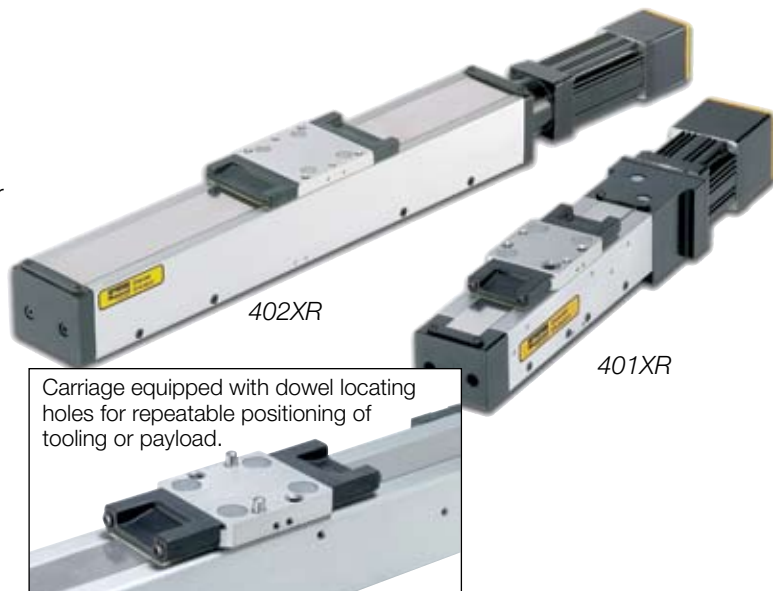

Common Specifications

		Precision*		Standard	
		401XR	402XR	401XR	402XR
Bidirectional Repeatability	2 mm lead	±1.3	–	±5	–
	5 or 10 mm lead	±1.3	±1.3	±12	±12
Duty Cycle	%	100	100	100	100
Maximum Acceleration	m/sec ² (in/sec ²)	20 (773)	20 (773)	20 (773)	20 (773)
Normal Load Capacity ⁽¹⁾	kgf (lbs)	50 (110)	100 (220)	50 (110)	100 (220)
Axial Load Capacity ⁽¹⁾	2 mm lead	5.5 (12.1)	–	5.5 (12.1)	–
	5 or 10 mm lead	15.5 (34.2)	38 (84)	15.5 (34.2)	38 (84)
Drive Screw Efficiency	%	80	80	80	80
Maximum Breakaway Torque	Nm (in-oz)	0.03 (4.2)	0.086 (12.0)	0.03 (4.2)	0.086 (12.0)
Maximum Running Torque ⁽²⁾	Nm (in-oz)	0.028 (4.0)	0.08 (11.3)	0.028 (4.0)	0.08 (11.3)
Linear Bearing Coefficient of Friction		0.01	0.01	0.01	0.01
Ballscrew Diameter	2 mm lead	6	–	6	–
	5 or 10 mm lead	8	12	8	12
Carriage Weight	kg (lbs)	0.045 (0.1)	0.11 (0.25)	0.045 (0.1)	0.11 (0.25)

* Requires linear encoder option E3 or E4. (1) Refer to life load charts found later in this section. (2) Ratings established at 2 rps.

Travel/Screw Lead Dependent Specifications

Travel (mm)	Positional Accuracy* (µm)				Straightness & Flatness		Input Inertia (10 ⁻⁵ kg-m ²)				Max Screw Speed (revs/sec)		Unit Weight (kg)	
	401XR		402XR		401XR	402XR	401XR		402XR		401XR	402XR	401XR	402XR
	Precision	Standard	Precision	Standard	2 mm	10 mm	2 mm	10 mm	2 mm	10 mm	401XR	402XR	401XR	402XR
50	10	20	–	–	20	–	0.6	–	–	–	100	–	1.0	–
100	10	20	10	20	20	20	0.9	–	12.0	–	100	90	1.2	2.3
150	12	20	12	20	20	20	1.1	–	15.0	–	100	90	1.3	2.6
200	16	30	16	30	25	25	–	4.7	20.0	–	100	90	1.5	2.8
300	18	40	18	40	25	25	–	5.2	–	25.0	100	90	1.7	3.2
400	–	–	21	40	–	30	–	–	–	29.0	–	95	–	3.8
600	–	–	25	50	–	30	–	–	–	39.0	–	50	–	4.8

*Accuracy stated is at 20°C utilizing slope correction factor provided.



404XR Series (95 mm wide profile)

The 404XR is a sleek compact positioner (47.3 x 95 mm profile) capable of carrying 170 kg loads up to a distance of 700 mm. Its quick and accurate positioning capability can be attributed to a high strength extruded housing, square rail ball bearing system, and precision ground ballscrew drive.

With its low profile design the 404XR is ideal for height restricted applications, and its lightweight construction makes it well suited as secondary axes on multi-axis systems. These units offer a wide array of easily adapted options and accessories which permit easy configuration to specific requirements.



Parallel Motor Mount
(with limit/home sensor pack option)

Common Specifications

		Precision	Standard
Bidirectional Repeatability ⁽⁵⁾	µm	±1.3	±3
Duty Cycle			
Ballscrew	%	100	100
Leadscrew		–	75
Maximum Acceleration	m/sec ² (in/sec ²)	20 (773)	20 (773)
Normal Load Capacity ⁽¹⁾	kgf (lbs)	170 (375)	170 (375)
Axial Load Capacity ⁽²⁾			
Ballscrew	kgf (lbs)	90 (198)	90 (198)
Leadscrew		–	25 (55)
Drive Screw Efficiency			
Ballscrew	%	90	90
Leadscrew		30	30
Maximum Breakaway Torque	Nm (in-oz)	0.13 (18)	0.18 (26)
Maximum Running Torque ⁽³⁾	Nm (in-oz)	0.11 (16)	0.17 (24)
Linear Bearing Coefficient of Friction		0.01	0.01
Ballscrew Diameter	mm	16	16
Carriage Weight	kg (lbs)	0.70 (1.55)	0.70 (1.55)

- (1) Refer to life load charts found later in this section.
- (2) Axial load for parallel mount is limited by a maximum input torque of 25 Nm.
- (3) Ratings established at 2 rps.
- (4) Positional accuracy applies to in-line motor configurations only. Contact factory for parallel motor specifications.
- (5) Consult factory for specifications with linear encoder.
- (6) Consult factory for higher screw speeds.

Travel/Screw Lead Dependent Specifications

Travel (mm)	Positional Accuracy ^{(4) (5)} (µm)		Straightness & Flatness	Input Inertia (10 ⁻⁵ kg-m ²)			Max Screw Speed ⁽⁶⁾ (revs/sec)	Unit Weight (kg)
	Precision	Standard		5 mm	10 mm	20 mm		
50	8	12	6	1.68	1.81	2.34	60	2.8
100	8	12	6	1.93	2.07	2.60	60	3.0
150	10	14	9	2.19	2.32	2.85	60	3.3
200	12	20	10	2.44	2.57	3.11	60	3.6
250	12	22	12	2.69	2.83	3.36	60	3.9
300	14	24	13	2.95	3.08	3.61	60	4.2
350	14	26	15	3.20	3.33	3.87	60	4.5
400	16	26	16	3.46	3.59	4.12	60	4.8
450	19	28	18	3.71	3.84	4.37	60	5.1
500	21	34	19	3.96	4.10	4.63	60	5.4
550	23	36	21	4.22	4.35	4.88	60	5.7
600	25	40	22	4.47	4.60	5.14	54	6.0

Screw Driven Tables



406XR Series (150 mm wide profile)

The 406XR can position high loads (up to 630 kgf) over distances up to two meters. Because of its size and strength (270 Nm, 200 lb-ft moment load capacity) this durable table is ideal as the base unit in a multi-axis system. From high resolution to high throughput, selectable ballscrew leads (5, 10, 20, 25 mm) make the desired resolution/velocity ratio easy to achieve, and stainless steel seal strips alleviate environmental concerns.

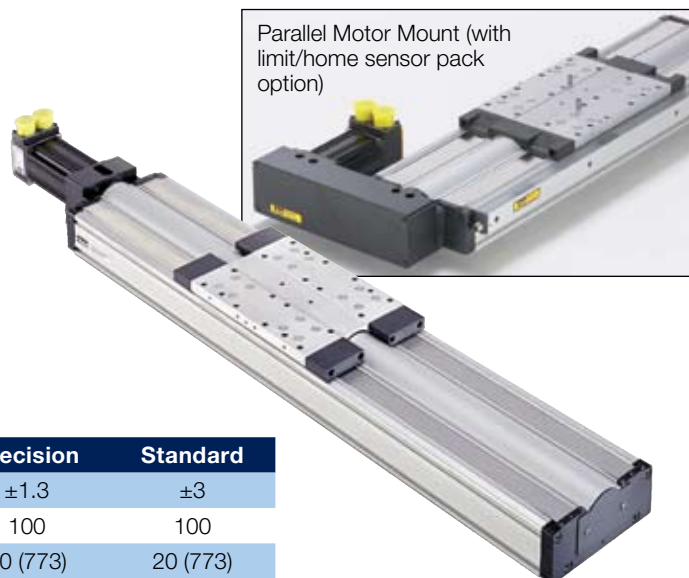

Common Specifications

		Precision	Standard
Bidirectional Repeatability ⁽⁵⁾	µm	±1.3	±3
Duty Cycle	%	100	100
Maximum Acceleration	m/sec ² (in/sec ²)	20 (773)	20 (773)
Normal Load Capacity ⁽¹⁾	kgf (lbs)	630 (1390)	630 (1390)
Axial Load Capacity ⁽²⁾			
0 to 600 mm Travel	kgf (lbs)	90 (198)	90 (198)
700 to 2000 mm Travel		–	200 (440)
Drive Screw Efficiency	%	90	90
Maximum Breakaway Torque			
0 to 600 mm Travel	Nm (in-oz)	0.13 (18)	0.18 (26)
700 to 2000 mm Travel		–	0.39 (55)
Maximum Running Torque ⁽³⁾			
0 to 600 mm Travel	Nm (in-oz)	0.11 (16)	0.17 (24)
700 to 2000 mm Travel		–	0.34 (48)
Linear Bearing Coefficient of Friction		0.01	0.01
Ballscrew Diameter			
0 to 600 mm Travel	mm	16	16
700 to 2000 mm Travel		–	25
Carriage Weight	kg (lbs)	2.7 (5.94)	2.7 (5.94)

- (1) Refer to life load charts found later in this section.
- (2) Axial load for parallel mount is limited to: 140 lbs for the 5, 10 and 20 mm lead drives; 104 kg (230 lbs) for 25 mm lead drives
- (3) Ratings established at 2 rps.
- (4) Positional accuracy applies to in-line motor configurations only. Contact factory for parallel motor specifications.
- (5) Consult factory for specifications with linear encoder.
- (6) Consult factory for higher screw speeds.

Travel/Screw Lead Dependent Specifications

Travel (mm)	Positional Accuracy ^{(4) (5)} (µm)		Straightness & Flatness	Input Inertia (10 ⁻⁵ kg-m ²)				Max Screw Speed ⁽⁶⁾ (revs/sec)	Unit Weight (kg)
	Precision	Standard		5 mm	10 mm	20 mm	25 mm		
100	8	12	6	3.34	3.85	5.90	–	60	8.7
200	12	20	10	3.92	4.43	6.48	–	60	10.0
300	14	24	13	4.50	5.01	7.06	–	60	11.3
400	16	26	16	5.08	5.59	7.64	–	60	12.6
500	21	34	19	5.65	6.17	8.22	–	55	13.9
600	25	40	22	6.23	6.75	8.80	–	44	15.2
700	–	92	25	36.51	37.02	–	40.61	47	19.2
800	–	94	29	39.96	40.47	–	44.07	47	20.7
900	–	103	32	43.41	43.93	–	47.52	47	22.2
1000	–	105	35	46.87	47.38	–	50.97	47	23.7
1250	–	118	42	55.50	56.01	–	59.61	35	27.6
1500	–	134	50	64.14	64.65	–	68.24	26	31.4
1750	–	154	57	72.77	73.28	–	76.88	20	35.2
2000	–	159	65	81.40	81.92	–	85.51	16	39.1



412XR Series (285 mm wide profile)

The 412XR is a rugged heavy duty linear table (285 mm x 105 mm profile) that enables massive loads (up to 1470 kgf) to be precisely positioned over distances up to two meters. Single point “easy lube” port is standard on carriage assembly for simple servicing and a convenient adapter plate (#100-6784-01) is available for easy X-Y configuration.

An unrivaled array of options combined with mounting compatibility with the smaller 400XR tables makes the 412XR ideal as the base unit for multi-axis positioning of heavier payloads.



Screw Driven Tables

Common Specifications

		Standard	
Screw Lead	mm	5, 10, 25	32
Bidirectional Repeatability ⁽⁴⁾	µm	±5	±5
Duty Cycle	%	100	100
Maximum Acceleration	m/sec ² (in/sec ²)	20 (773)	20 (773)
Normal Load Capacity ⁽¹⁾	kg (lbs)	1470 (3241)	1470 (3241)
Axial Load Capacity	kg (lbs)	200 (441)	460 (1014)
Drive Screw Efficiency	%	90	80
Maximum Breakaway Torque	Nm (in-oz)	0.61 (86)	0.76 (108)
Maximum Running Torque ⁽²⁾	Nm (in-oz)	0.55 (78)	0.69 (98)
Linear Bearing Coefficient of Friction		0.01	0.01
Ballscrew Diameter	mm	25	32
Carriage Weight	kg (lbs)	12 (27)	13 (28)

- (1) Refer to life load charts found later in this section.
- (2) Ratings established at 2 rps.
- (3) Positional accuracy applies to in-line motor configurations only. Contact factory for parallel motor specifications.
- (4) Consult factory for specifications with linear encoder.
- (5) Consult factory for higher screw speeds.

Travel/Screw Lead Dependent Specifications

Travel (mm)	Positional Accuracy ^{(3) (4)} (µm)	Straightness & Flatness	Input Inertia (10 ⁻⁵ kg-m ²)				Max Screw Speed ⁽⁵⁾ (revs/sec)		Unit Weight (kg)	
			5 mm	10 mm	25 mm	32 mm	5, 10, 25 mm	32 mm	5, 10, 25 mm	32 mm
150	64	9	27.20	29.45	46.76	98.20	47	42	39.6	41.5
250	66	12	30.21	32.46	49.78	106.28	47	42	42.9	45.0
350	71	15	33.23	35.48	52.79	114.37	47	42	46.2	48.5
650	91	24	42.27	44.52	61.83	138.63	47	42	56.1	59.0
800	94	29	46.79	49.04	66.35	150.76	47	42	61.0	64.2
1000	105	35	52.81	55.06	72.37	166.94	45	42	67.6	71.2
1250	118	42	58.84	61.09	78.40	183.11	34	41	74.2	78.2
1500	134	50	67.87	70.12	87.44	207.38	24	31	84.1	88.7
1750	154	57	75.41	77.66	94.97	227.59	18	24	92.4	97.5
2000	159	65	82.94	85.19	102.50	247.81	15	19	100.6	106.2

400XR Series Life/Load

The following performance information is provided as a supplement to the product specifications pages. The following graphs are used to establish the table life relative to the applied loads. The useful life of a linear table at full catalog specifications is dependent on the forces acting upon it. These forces include both static components resulting from payload weight, and dynamic components due to acceleration/ deceleration of the load. In multi-axes applications, the primary positioner at the bottom of the stack usually establishes the

load limits for the combined axes. When determining life/load, it is critical to include the weight of all positioning elements that contribute to the load supported by the primary axis. **Catalog load specifications are rated for 100 million inches of travel or 2,540 km.**

For final evaluation of life vs load, including off center, tension, and side loads refer to the charts and formulas found on our web site at www.parkermotion.com.

Normal Load (Compression)

These graphs provide a “rough cut” evaluation of the support bearing life/load characteristics. The curves show the life/load relationship when the applied load is centered on the carriage, normal (perpendicular) to the carriage mounting surface.

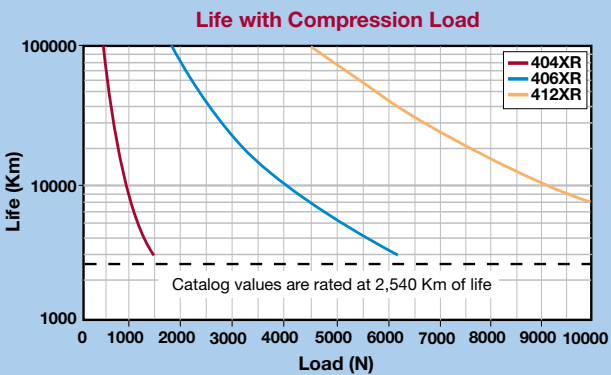
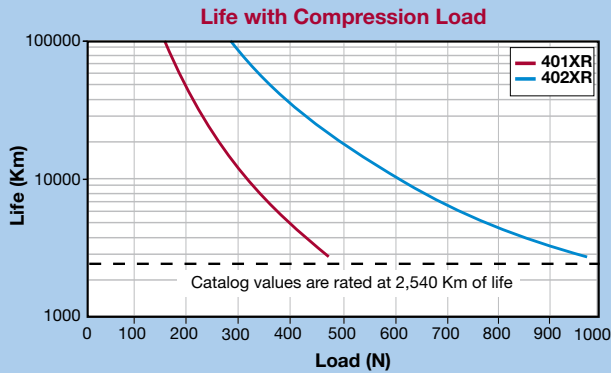

Axial Load (Thrust)

These graphs illustrate table ballscrew life relative to the axial load.

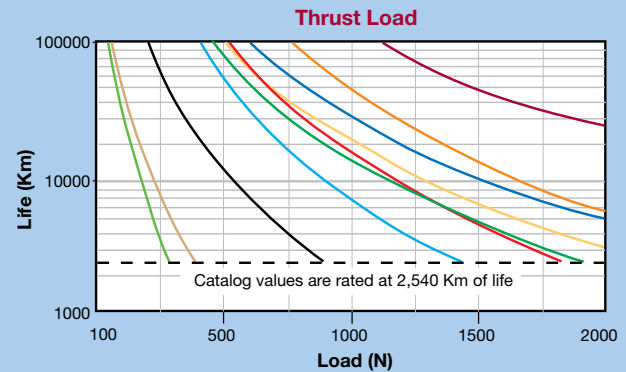
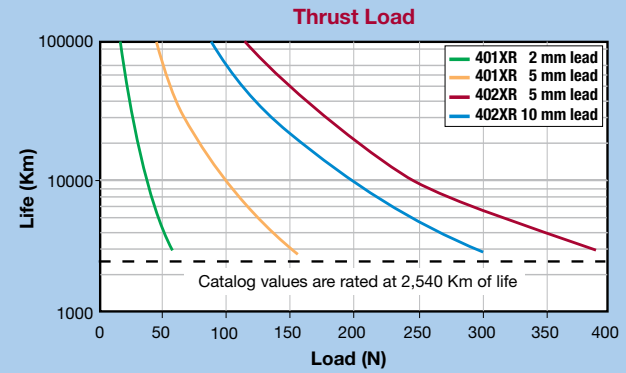

- 404 - 406XR 20 mm lead x 16 mm dia.
- 404 - 406XR 10 mm lead x 16 mm dia.
- 404 - 406XR 5 mm lead x 16 mm dia.
- 404 - 406XR 25 mm lead x 25 mm dia.
- 404 - 406XR 10 mm lead x 25 mm dia.
- 404 - 406XR 5 mm lead x 25 mm dia.
- 412XR 5 mm lead x 25 mm dia.
- 412XR 10 mm lead x 25 mm dia.
- 412XR 25 mm lead x 25 mm dia.
- 412XR 32 mm lead x 32 mm dia.



400XR Series Bearing Life/Load*

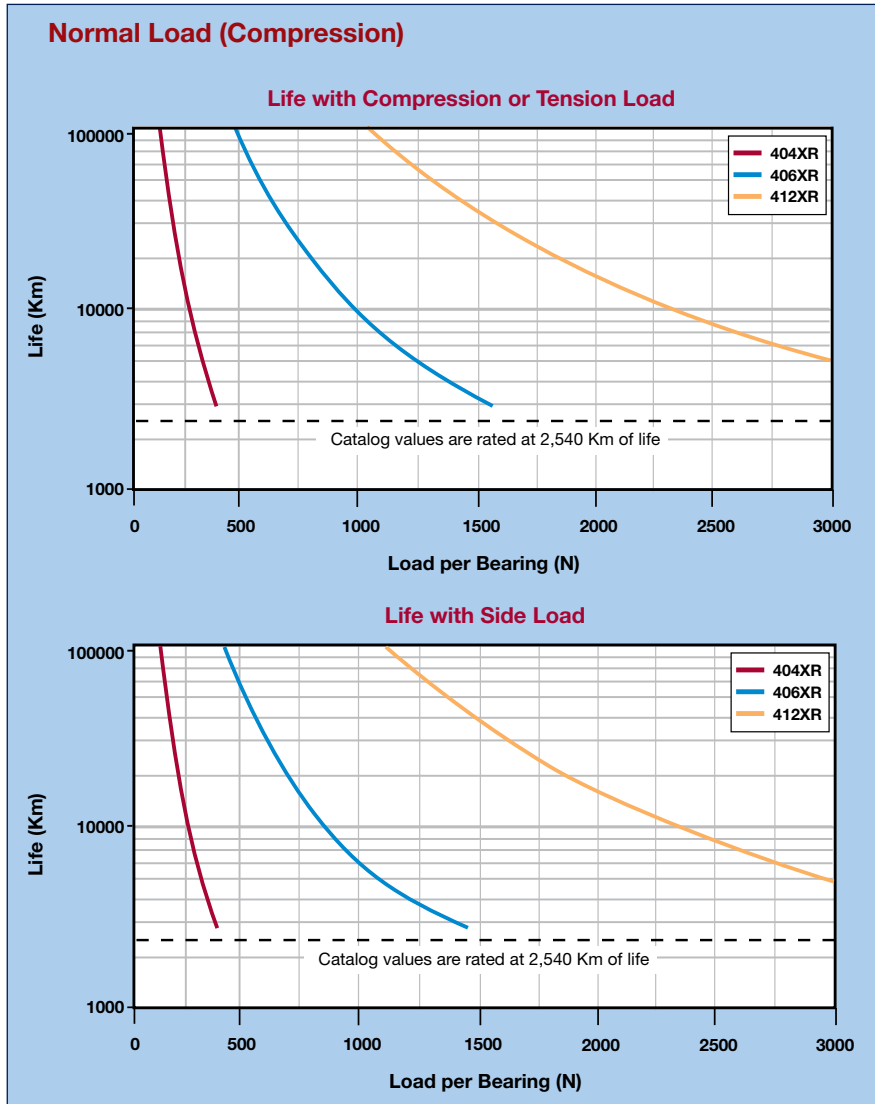

These charts are to be used in conjunction with the corresponding formulas found in the product manuals at www.parkermotion.com to establish the life/load for each bearing (4 per table).

Several dimensions, which are specific to each linear positioning table model, and the load geometry are required for these computations. These dimensions are supplied in the catalog information for each positioner. The dimensions are referenced as follows:

- d1** bearing block center-to-center longitudinal spacing
- d2** bearing rail center-to-center lateral spacing
- da** Rail center-to-carriage mounting surface

	d1	d2	da
404XR	80	57	28
406XR	114	90.3	42.5
412XR	205	192	43

Refer to Parker's website www.parkermotion.com for moment loading and other engineering data.

*For 401XR and 402XR moment loading capacities, please refer to the maintenance manual.

Screw Driven Tables



Home or Limit Sensor Options

End of Travel and Home Sensors for the 400XR series are available in a variety of styles. The sensors can be ordered as part of the table or as separate components with the associated mounting hardware or in an enclosed sensor pack. A 5 meter high-flex extension cable (Part No. 003-2918-01) is included for use with the 401XR thru 406XR models having the locking connector option.

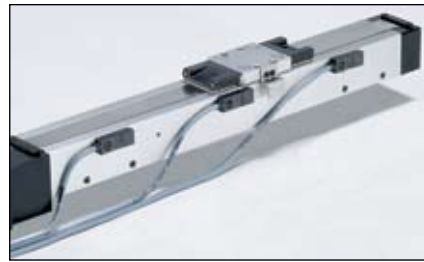

401XR Limits and Home Sensor

- NPN (Sinking) or PNP (Sourcing)
- Normally Closed (N.C.) or Normally Open (N.O.)
- Flying Leads or Locking Connector

Specifications	
Input Power	5-30 VDC, 20 mA
Output	100mA max
Wire Color	(+) Supply: Brown
Code	(-) Supply: Blue NO Output: Black NC Output: White

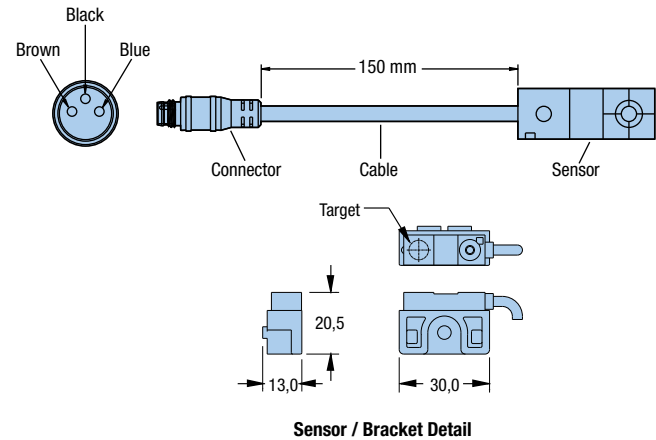

Order Code	Part Number*	Switch Type	Logic	Cable Length	Connector Option
H2 or L2	006-1639-01	N.C.	Sinking	3.0 m	Flying Leads
H3 or L3	006-1639-02	N.O.	Sinking	3.0 m	Flying Leads
H4 or L4	006-1639-03	N.C.	Sourcing	3.0 m	Flying Leads
H5 or L5	006-1639-04	N.O.	Sourcing	3.0 m	Flying Leads
H6 or L6	006-1639-09	N.C.	Sinking	150 mm	Locking Connector
H7 or L7	006-1639-08	N.O.	Sinking	150 mm	Locking Connector
H8 or L8	006-1639-11	N.C.	Sourcing	150 mm	Locking Connector
H9 or L9	006-1639-10	N.O.	Sourcing	150 mm	Locking Connector
H11 or L11	See chart below	N.C.	Sinking	See chart below	Sensor Pack
H12 or L12	See chart below	N.O.	Sinking	See chart below	Sensor Pack
H13 or L13	See chart below	N.C.	Sourcing	See chart below	Sensor Pack
H14 or L14	See chart below	N.O.	Sourcing	See chart below	Sensor Pack

* Applies to 401XR thru 406XR models. 412XR models have limits and homes internally mounted with a connector termination. Sensor triggers (targets) ordered separately.

Sensor Pack Cable



406XR with Limit and Home Sensor Pack

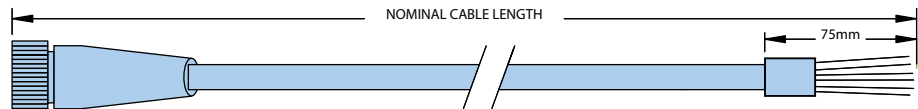

Description	Part Number	Wire Color	Function	Pin Number
3 Meters	006-1742-01	Red	+5 to +24 VDC	A
7.5 Meters	006-1742-02	Blue	Limit 1 (LXR -)	B
		Orange	Limit 2 (LXR +)	C
		Green	Home	D
		Black	Ground	E
		Green/Yellow	Shield	Shield Case



Linear Encoder Options (Tape Scale)

A linear position feedback device which mounts directly to the table carriage. (Factory installation required.)



- 1.0 μm resolution
- 0.5 μm resolution
- 0.1 μm resolution

Specifications

Input Power	5 VDC, 150mA
Output	A/B quadrature and reference mark, differential line drive output
Resolution	1.0, 0.5, 0.1 micron
Cable Length	3 m



401XR with Linear Encoder plus Sensor Pack

Rotary Encoder Option

Modular rotary encoder couples directly to the drive screw for position feedback and is easily field installed. The rotary encoder cannot be installed with the brake assembly option.

- 5000 counts/rev

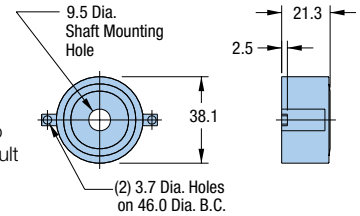

Note: Dimensions shown apply to 404XR and 406XR models. Consult factory for 412XR dimensions.

Specifications

Input Power	5 VDC, 135 mA
Output	A/B quadrature and reference mark, differential line drive output
Resolution	1250 lines/rev equals 5000 counts post quadrature (1 μm with 5 mm lead ballscrew)
Cable Length	150 mm

Screw Driven Tables

Brake Assembly Option

Electromagnetic brake assembly used to prevent “backdriving” in vertical applications. The brake option includes a 5 m extension cable. The brake option is easily field installed. The brake option cannot be installed with the rotary encoder option.

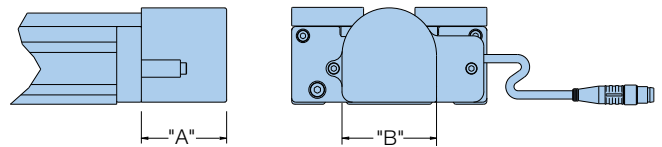

404XR with Brake Option

Table Series	Part Number	Input Power	Holding Torque	Dimensions (mm)	
				A	B
401XR/402XR	—	—	—	—	—
404XR	006-1627-01	24 VDC, 0.46 A	2.0 Nm	41.5	46.0
406XR	006-1656-01	24 VDC, 0.5 A	4.5 Nm	49.9	57.5
412XR	002-1916-01	24 VDC, 0.75 A	9.0 Nm	54.0	72.0

Dowel Pinning Options*

Standard dowel pin locating holes are offered on most 400XR units to facilitate repeatable mounting of tooling or payload.*

In addition, pinning options are offered for precise orthogonal mounting of the second axis in a multi-axis system. In this case, the bottom side of the table base is match drilled and reamed to the first axis to provide exact orthogonal location. This convenient option eliminates concerns regarding contamination or damage often associated with machining for locating pins in an assembled unit.

*Not available with 401XR or 402XR or 50 mm travel 404XR.

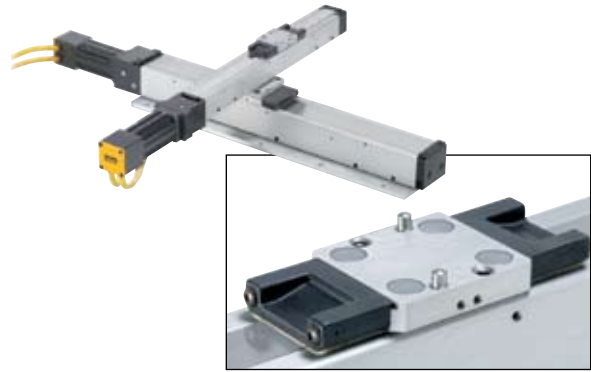

Two locating dowel pins shown in carriage



400XR Series Accessories

Riser Plate Accessory

Used to raise the table base to provide clearance for motors.

Model	Part Number
401XR	002-2063-01
402XR	002-2064-01
404XR	002-3619-01
406XR	002-3625-01
412XR	—

401XR/402XR

Part Number: 002-2063-01/ 002-2064-01

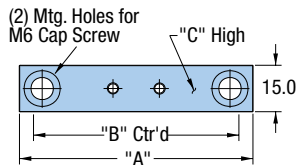
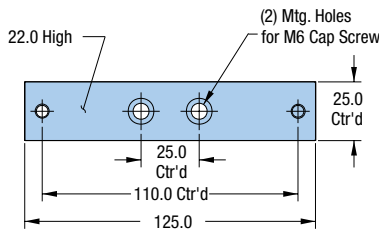

Table Series	Dimensions (mm)		
	A	B	C
401XR	65.0	50.4	17.0
402XR	90.0	75.4	10.0

404XR

Part Number: 002-3619-01



406XR

Part Number: 002-3625-01

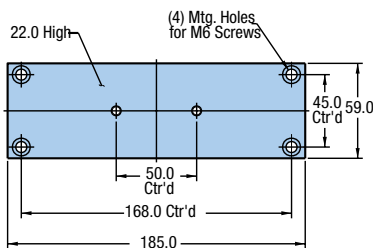

Toe Clamp Accessory

Used for convenient outboard mounting of table to a base plate, riser plates, Z-axis bracket, or other 400XR table. All hardware is included.

Model	Part Number
404XR	002-3618-01
406XR	002-3624-01
412XR	002-2160-01

404XR

Part Number: 002-3618-01

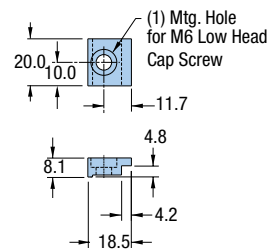

406XR

Part Number: 002-3624-01

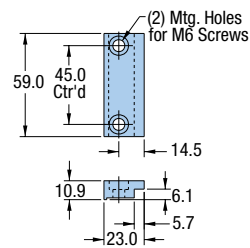

412XR

Part Number: 002-2160-01

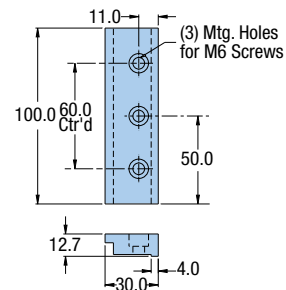

Screw Driven Tables

400XR Multi Axis Configurations



Base Axis (X) *	Second Axis (Y or Z)*									
	Orientation	401XR		402XR	404XR	404LXR	406XR	406LXR	412XR 412LXR	Wedge
		50 mm	>50 mm							
401XR	X-Y	002-2126-01	002-2065-01	—	—	—	—	—	—	—
	X-Y Cartesian	002-2123-01	002-2068-01	—	—	—	—	—	—	—
	X-Z	—	101-0955-01	—	—	—	—	—	—	—
	X-Z Side Mount	002-2123-01	101-0955-01	—	—	—	—	—	—	—
402XR	X-Y	002-2130-01	002-2066-01	002-2066-01	—	—	—	—	—	—
	X-Y Cartesian	002-2069-01	002-2069-01	002-2069-01	—	—	—	—	—	—
	X-Z	—	002-2069-01	002-2069-01	—	—	—	—	—	—
	X-Z Side Mount	002-2125-01	002-2069-01	002-2069-01	—	—	—	—	—	—
404XR 404LXR	X-Y	100-9193-01	100-9193-01	100-9193-01	Direct Mount*	100-9584-01	—	—	—	100-9274-01
	X-Y Carriage to Carriage	—	—	—	100-3945-01	100-3945-01	—	—	—	—
	X-Y Cartesian Right Hand	002-2162-02	002-2162-02	002-2162-02	—	—	—	—	—	—
	X-Y Cartesian Left Hand	002-2162-02	002-2162-02	002-2162-02	—	—	—	—	—	—
	X-Z	—	—	—	002-1839-01	—	—	—	—	—
	X-Z Side Mount	—	—	—	002-1840-01	—	—	—	—	—
406XR 406LXR	X-Y	100-9194-01	100-9194-01	100-9194-01	Direct Mount*	Direct Mount*	Direct Mount*	Direct Mount*	—	100-9274-01
	X-Y Carriage to Carriage	—	—	—	100-4191-01	100-4191-01	100-4191-01	100-4191-01	—	—
	X-Y Cartesian	—	—	—	002-2163-01	002-2163-01	—	—	—	—
	X-Z	—	—	—	002-1823-01	—	002-1817-01	—	—	—
X-Z Side Mount	—	—	—	002-1824-01	—	002-1818-01	—	—	—	
412XR 412LXR	X-Y	—	—	—	Direct Mount* or Toe Clamp	Direct Mount* or Toe Clamp	Direct Mount* or Toe Clamp	Direct Mount* or Toe Clamp	100-6784-01	—
	X-Y Cartesian	—	—	—	—	—	002-2164-01	002-2164-01	—	—
ZP 200 Wedge	X-Y	—	—	—	100-9274-01	100-9274-01 or Toe Clamp	100-9274-01 or Toe Clamp	100-9274-01	—	—

* An adaptor plate (100-3945-01) is required whenever the X-axis is a parallel motor mount model. If the Y-axis is 404XR with 50 mm stroke, a special plate or toe clamp option is required.



400XR Multi Axis Configurations

These diagrams show the most popular variations of multi-axis configurations. Both standard and custom brackets are available. Standard X-Y orientation will place the X axis motor at the 6 o'clock position and the Y axis motor at the 3 o'clock position.

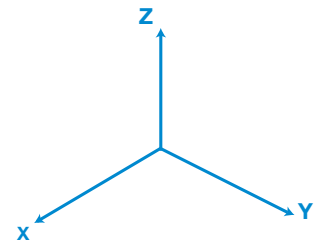

Screw Driven Tables

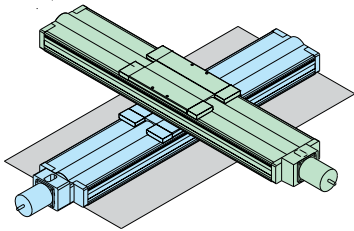

Figure 1
Two Axis (X-Y) Horizontal Mounting

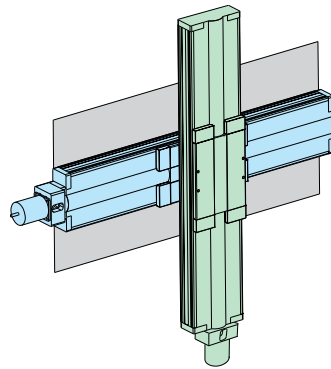

Figure 2
Two Axis (X-Z) Vertical Mounting

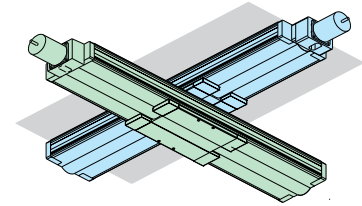

Figure 3
Two Axis (X-Y) Inverted Mounting

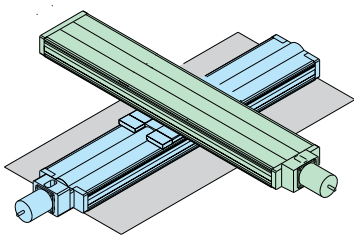

Figure 4
Two Axis-Carriage to Carriage (Y Axis Inverted)

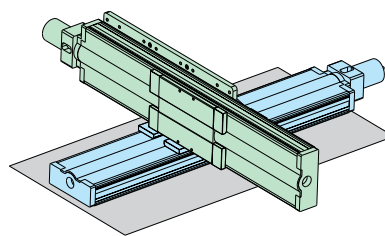

Figure 5
Two Axis (X-Y) Cartesian Horizontal Mounting

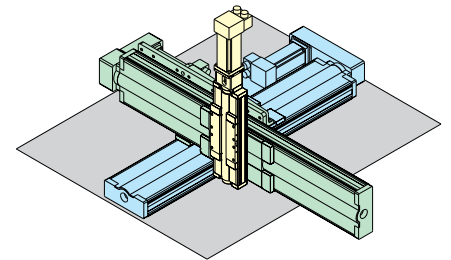

Figure 6
Three Axis (X-Y-Z) Cartesian Horizontal Mounting

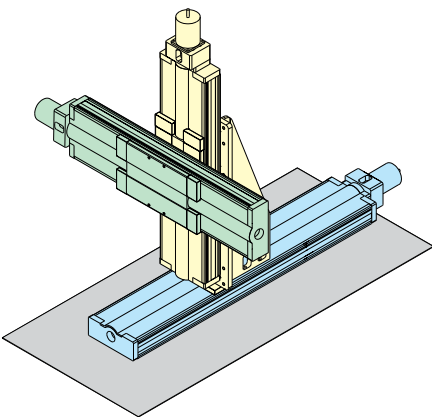

Figure 7
Three Axis (X-Z-Y) Horizontal Mounting

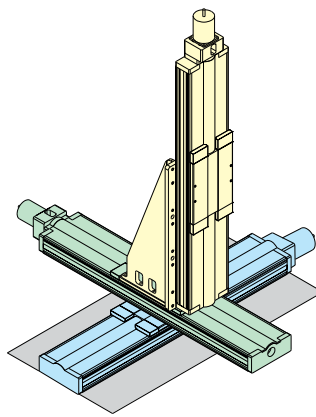

Figure 8
Three Axis (X-Y-Z) Horizontal Mounting

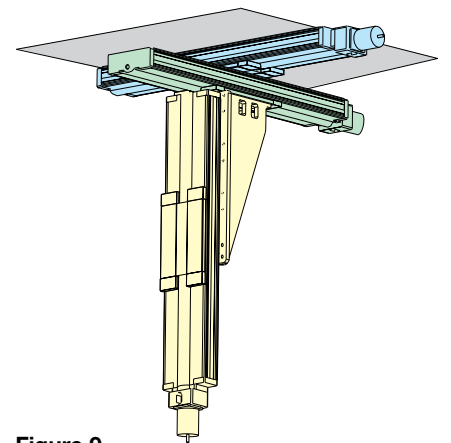
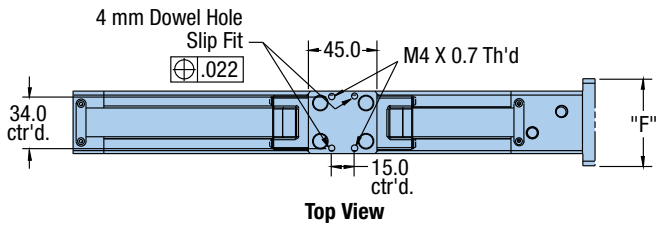

Figure 9
Three Axis (X-Y-Z) Inverted Mounting

401XR Dimensions

Dimensions (mm)



Top View

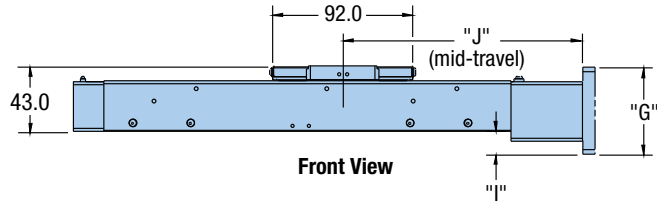

Front View

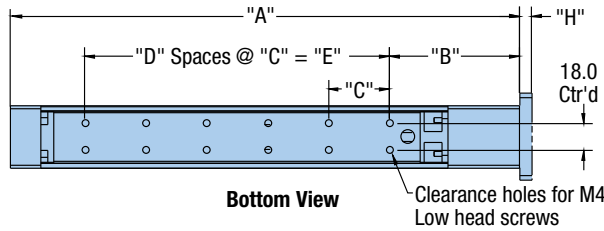

Bottom View

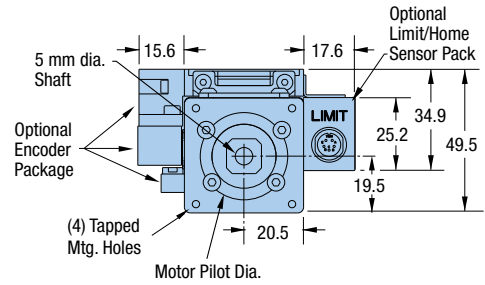

Enlarged End View
(with Encoder and Limit/Home Sensor Pack Option)

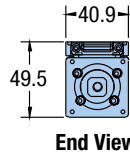

End View

Model	Travel (mm)	Dimensions (mm)					
		A	B	C	D	E	J
401050XR	50	209.3	82.8	80.0	1	80.0	123.0
401100XR	100	284.3	80.3	40.0	4	160.0	160.0
401150XR	150	334.3	85.3	40.0	5	200.0	185.0
401200XR	200	384.3	90.3	40.0	6	240.0	210.0
401300XR	300	509.3	92.8	40.0	9	360.0	260.0

Motor Size	Order Code	Dimensions (mm)			
		F	G	H	I
SM 16	M2	40.9	39.1	-	6.5
NEMA 23/SM 23	M3	57.2	57.2	4.0	15.6
NEMA 17	M37	40.9	39.1	-	6.5
BE 23	M61	57.2	57.2	8.0	15.6

In-Line Motor Adapters

Used to easily accommodate the mounting of different servo or stepper motors.

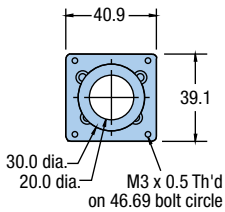

SM 16

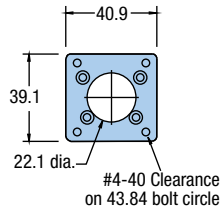

NEMA 17

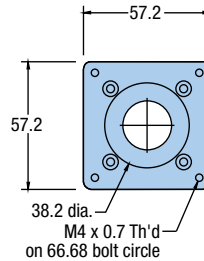

SM 23 or NEMA 23

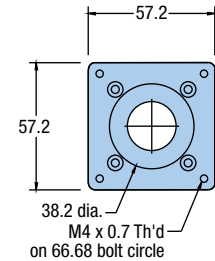

BE 23



402XR Dimensions

Dimensions (mm)

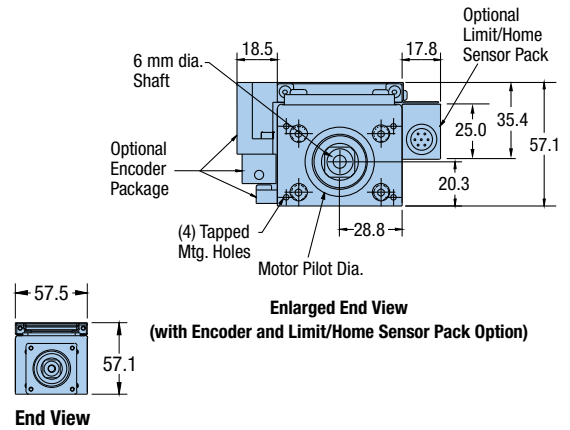
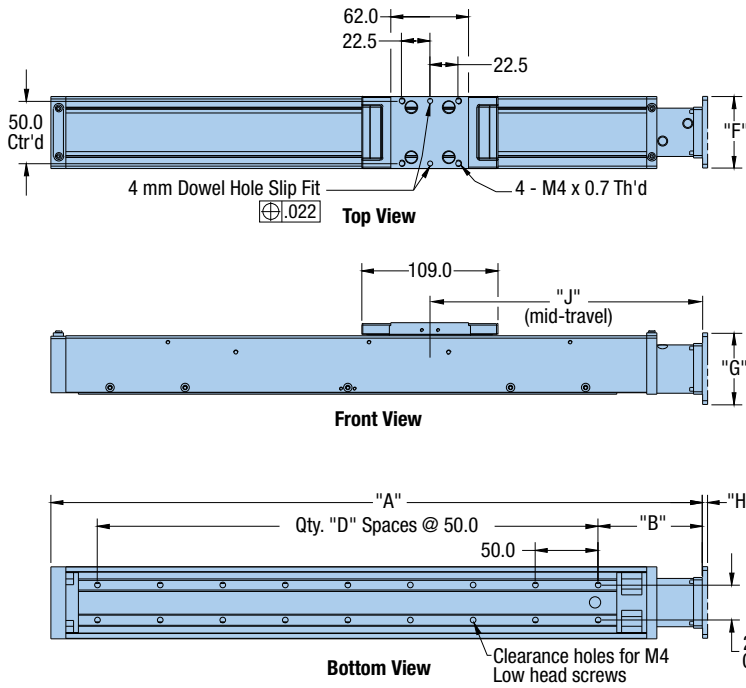

Screw Driven Tables

Model	Travel (mm)	Dimensions (mm)			
		A	B	D	J
402100XR	100	320.5	83.5	4	184.0
402150XR	150	370.5	83.5	5	214.0
402200XR	200	420.5	83.5	6	234.0
402300XR	300	520.5	83.5	8	284.0
402400XR	400	620.5	83.5	10	334.0
402600XR	600	820.5	83.5	14	434.0

Motor Size	Order Code	Dimensions (mm)		
		F	G	H
SM 16	M2	40.6	40.6	-
NEMA 23/SM 23	M3	57.2	57.2	4.0
NEMA 17	M37	40.6	40.6	-
BE 23	M61	57.2	57.2	8.0

In-Line Motor Adapters

Used to easily accommodate the mounting of different servo or stepper motors.

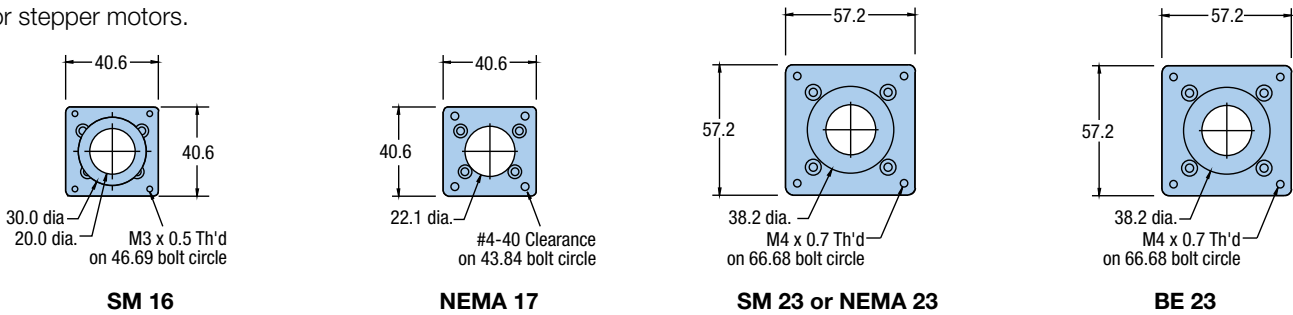

404XR Dimensions

Dimensions (mm)

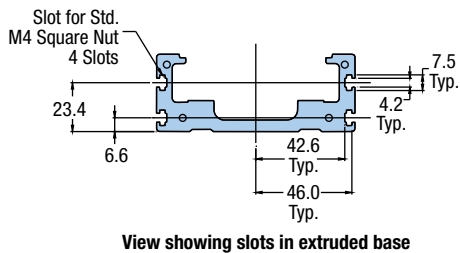
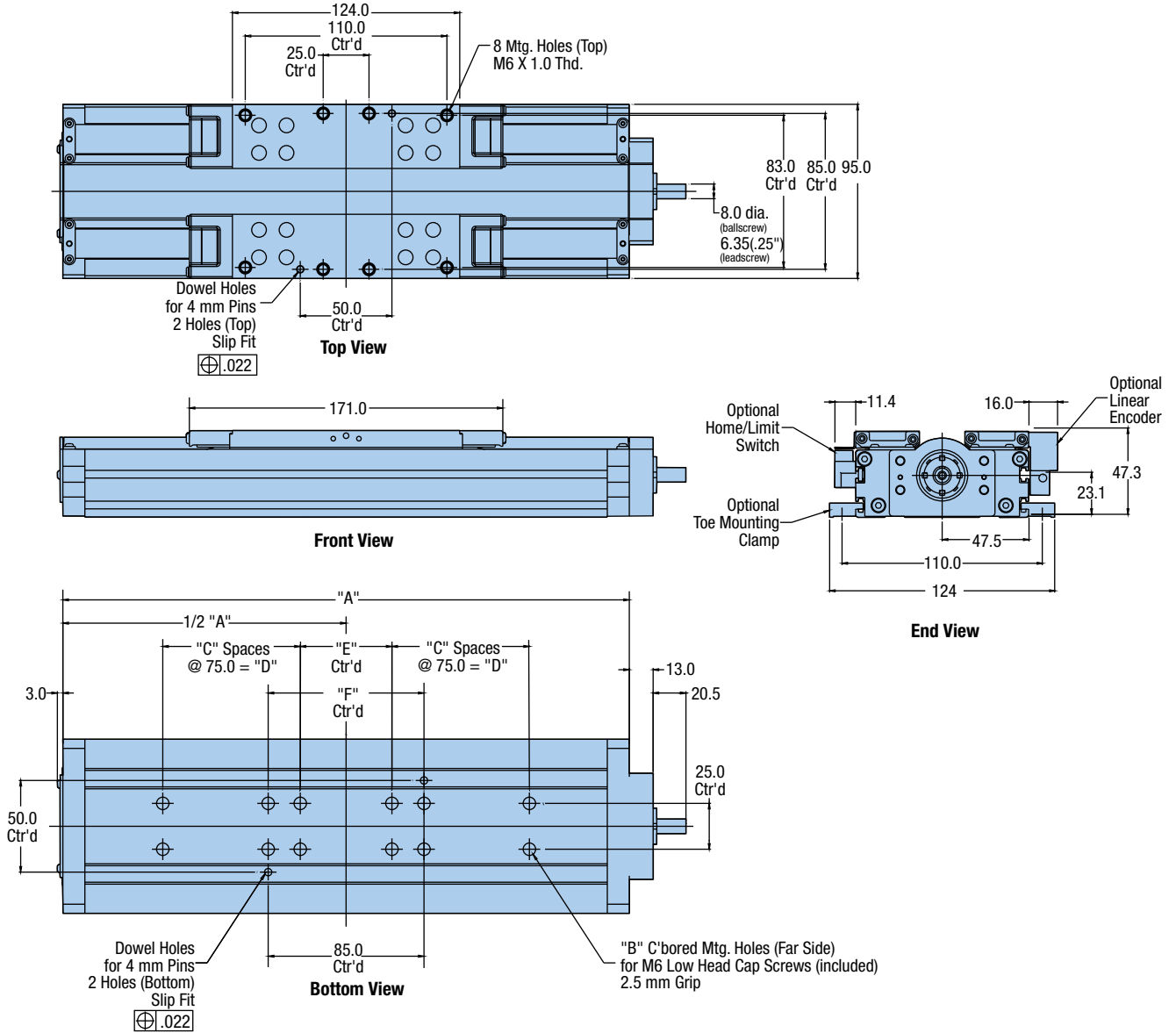

Model	Travel (mm)	Dimensions (mm)					
		A	B	C	D	E	F
404050XR	50	259	4	-	-	-	-
404100XR	100	309	12	1	75.0	50.0	85.0
404150XR	150	359	12	1	75.0	50.0	85.0
404200XR	200	409	12	1	75.0	50.0	85.0
404250XR	250	459	16	2	150.0	50.0	85.0
404300XR	300	509	16	2	150.0	50.0	85.0
404350XR	350	559	16	2	150.0	50.0	85.0
404400XR	400	609	20	3	225.0	50.0	85.0
404450XR	450	659	20	3	225.0	50.0	85.0
404500XR	500	709	20	3	225.0	50.0	85.0
404550XR	550	759	24	4	300.0	50.0	85.0
404600XR	600	809	24	4	300.0	50.0	85.0



404XR In-Line Motor Mounting

In-line motor mounting allows the motor to be mounted directly to the drive screw via the selected motor coupling.

Used to easily accommodate the mounting of different frame sizes. These adapter plates can be ordered separately by part number below.

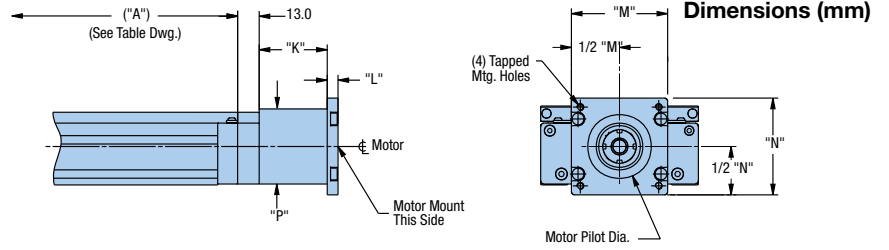

Dimensions (mm)							
Motor Size	Order Code	Max. Motor Shaft Ø	K	L	M	N	P
SM 16	M2	9.5	41.0	4.3	53.0	45.0	45.0
NEMA 23	M3	9.5	41.0	6.5	83.0	58.0	45.0
NEMA 34	M4	9.5	41.0	12.5	83.0	83.0	45.0
NEO 70	M21	11.0	53.0	-	69.9	69.9	69.9

Screw Driven Tables

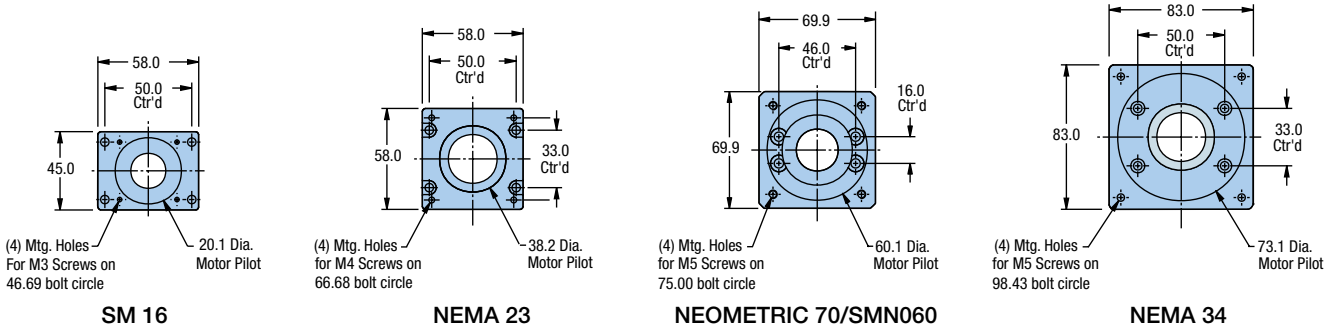

404XR Parallel Motor Mounting

Parallel motor mounting is employed whenever a shorter overall unit length is needed. The motor is positioned along the sides or bottom of the table as designated by position A, B, or C. (No coupling required.)

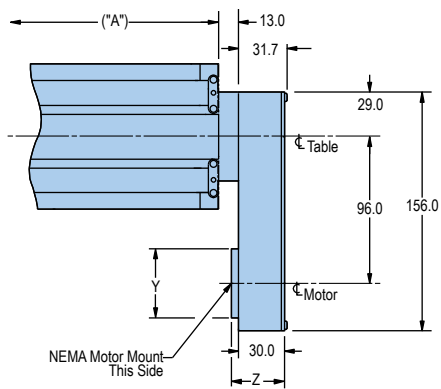

Dimensions			
Motor Size	Y (mm)	Z (mm)	Motor Shaft Ø
SM 16	45.0	34.5	0.250"
SM 23/BE 23	58.0	34.5	0.375"
NEMA 23	58.0	34.5	0.250"

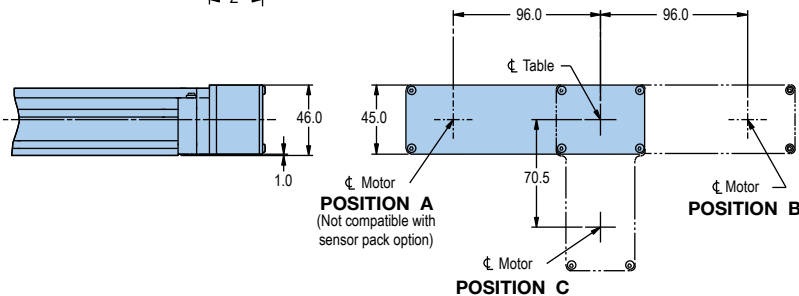
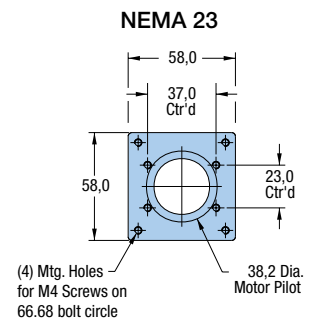
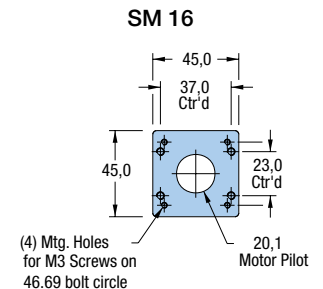

406XR Dimensions

Dimensions (mm)

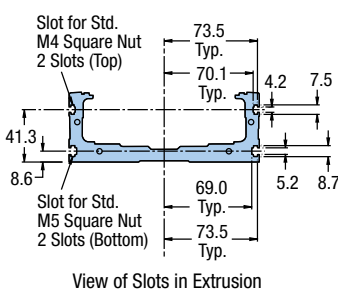
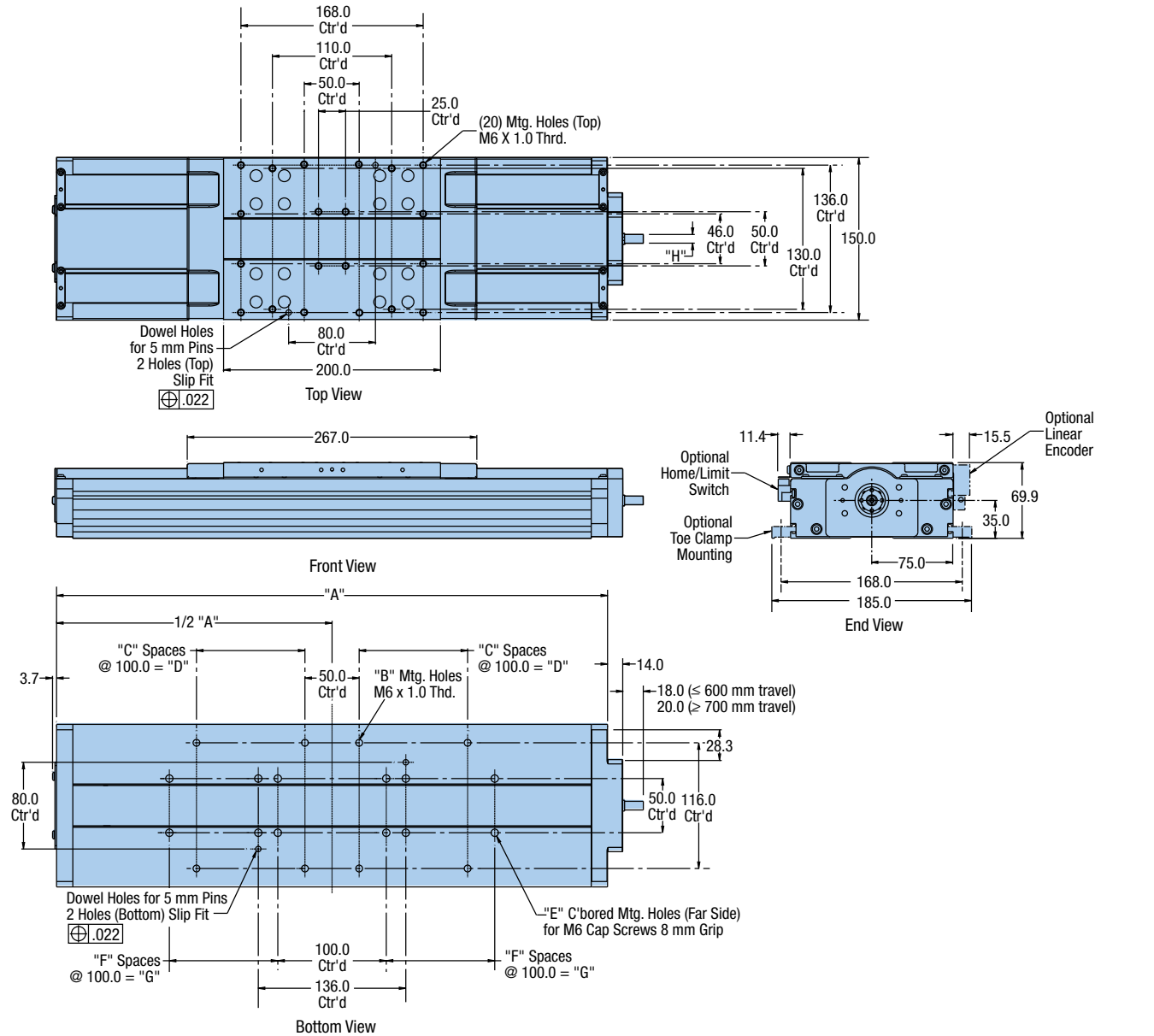

Model	Travel (mm)	Ballscrew Ø	Dimensions (mm)							
			A	B	C	D	E	F	G	H
4060100XR	100	16	408	8	1	100.0	12	1	100.0	8.0
4060200XR	200	16	508	8	1	100.0	12	1	100.0	8.0
4060300XR	300	16	608	12	2	200.0	16	2	200.0	8.0
4060400XR	400	16	708	12	2	200.0	16	2	200.0	8.0
4060500XR	500	16	808	16	3	300.0	20	3	300.0	8.0
4060600XR	600	16	908	16	3	300.0	20	3	300.0	8.0
4060700XR	700	25	1008	20	4	400.0	24	4	400.0	10.0
4060800XR	800	25	1108	20	4	400.0	24	4	400.0	10.0
4060900XR	900	25	1208	24	5	500.0	28	5	500.0	10.0
4061000XR	1000	25	1308	24	5	500.0	28	5	500.0	10.0
4061250XR	1250	25	1558	32	7	700.0	32	6	600.0	10.0
4061500XR	1500	25	1808	36	8	800.0	40	8	800.0	10.0
4061750XR	1750	25	2058	40	9	900.0	44	9	900.0	10.0
4062000XR	2050	25	2308	44	10	1000.0	48	10	1000.0	10.0



406XR In-Line Motor Mounting

In-line motor mounting allows the motor to be mounted directly to the drive screw via the selected motor coupling.

Used to easily accommodate the mounting of different frame sizes. These adapter plates can be ordered separately by part number below.

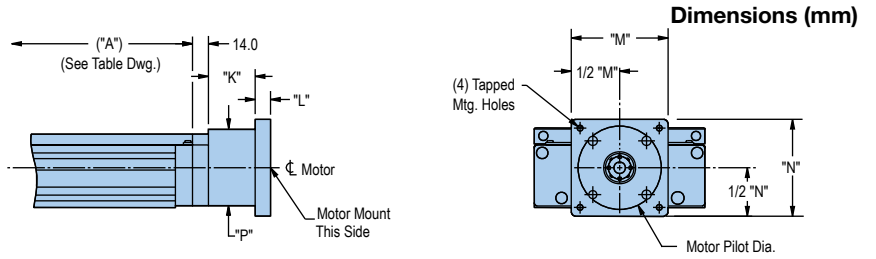

Motor Size	Order Code	Max. Motor Shaft Ø	Dimensions (mm)				
			K	L	M	N	P
MPP092	M90	16.0	53.0	12.5	92.0	92.0	69.0
NEMA 23/SM 23	M3	9.5	41.0	–	85.0	67.0	67.0
NEMA 34	M4	16.0	53.0	13.5	85.0	85.0	70.0
NEO 34	M17	16.0	53.0	13.5	85.0	85.0	70.0
NEO 70	M21	16.0	53.0	–	85.0	70.0	70.0
NEO 92	M29	16.0	53.0	12.5	92.0	92.0	70.0

Screw Driven Tables

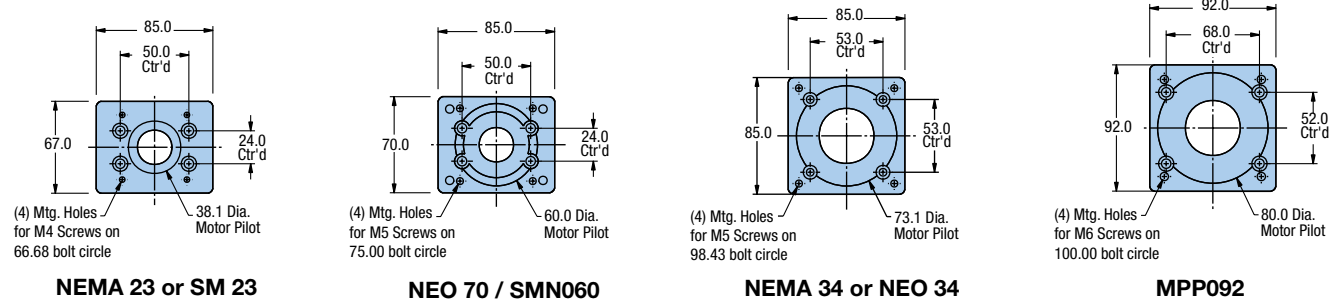

406XR Parallel Motor Mounting

Parallel motor mounting is employed whenever a shorter overall unit length is needed. The motor is positioned along the sides or bottom of the table as designated by position A, B, or C. (No coupling required.)

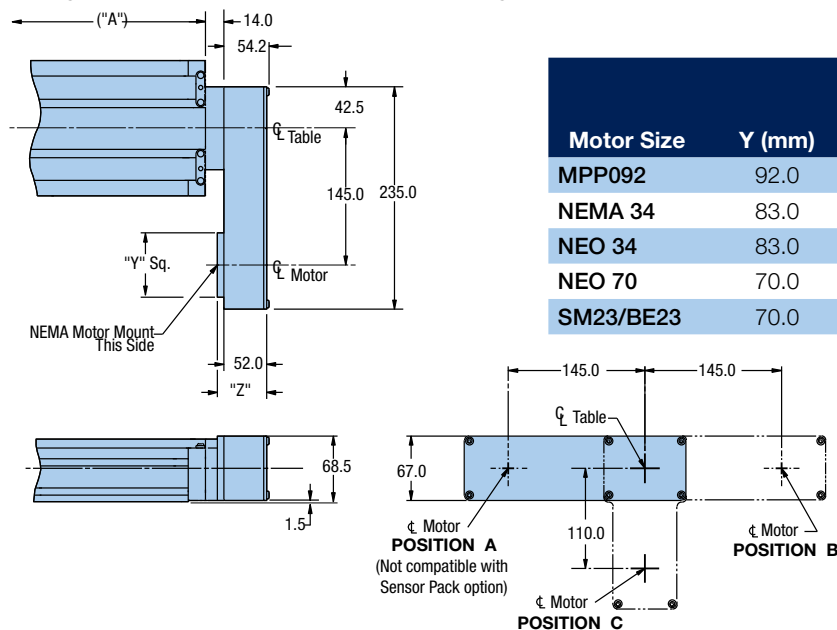

Motor Size	Y (mm)	Z (mm)	Motor Shaft Ø
MPP092	92.0	65.7	16.0 mm
NEMA 34	83.0	62.0	0.375"
NEO 34	83.0	62.0	0.500"
NEO 70	70.0	60.0	11.0 mm
SM23/BE23	70.0	57.5	0.375"

412XR Dimensions

Dimensions (mm)

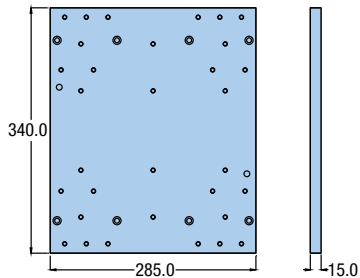
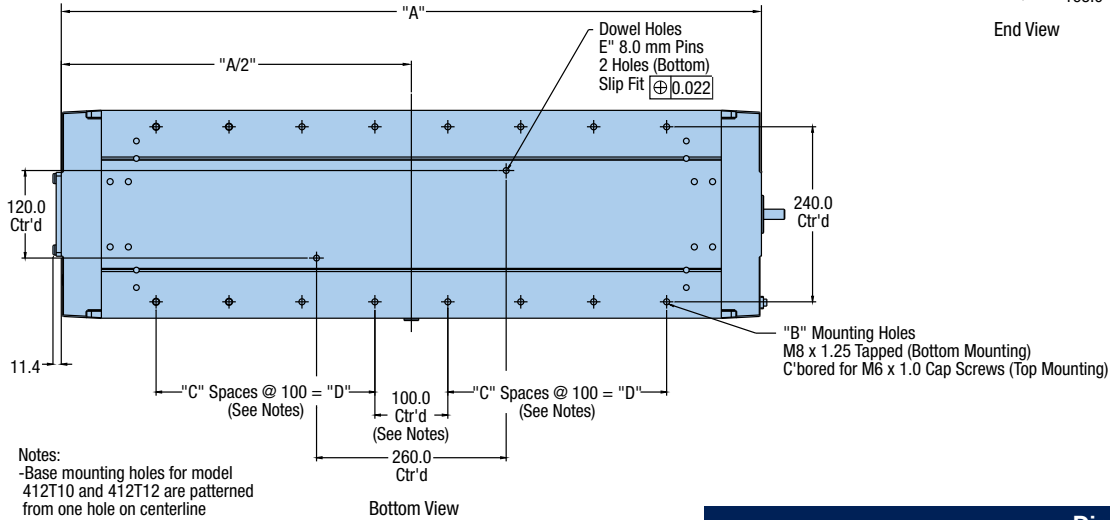
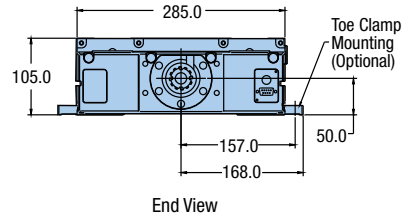
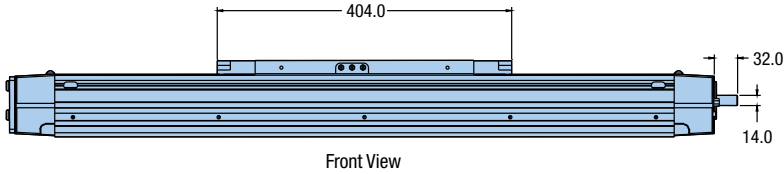
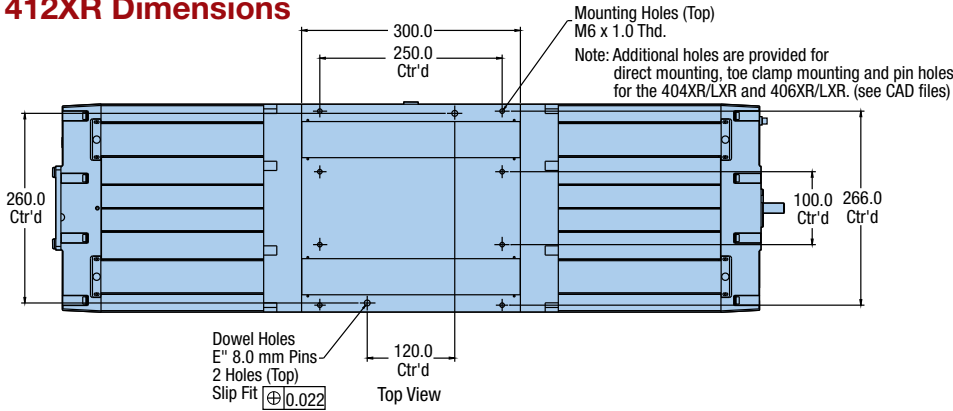

X-Y Adapter Plate #100-6784
(Used to mount any 404XR, 406XR or 412XR with toe clamps)

Model	Travel (mm)	Dimensions (mm)			
		A	B	C	D
412T01	150	764	12	2	200
412T02	250	864	16	3	300
412T03	350	964	16	3	300
412T04	650	1264	24	5	500
412T05	800	1414	24	5	500
412T06	1000	1614	28	6	600
412T07	1200	1814	32	7	700
412T08	1500	2114	40	9	900
412T09	1750	2364	44	10	1000
412T10	2000	2614	50	12	1200



412XR In-Line Motor Mounting

In-line motor mounting allows the motor to be mounted directly to the drive screw via the selected motor coupling.

Used to easily accommodate the mounting of different frame sizes. These adapter plates can be ordered separately by part number below.

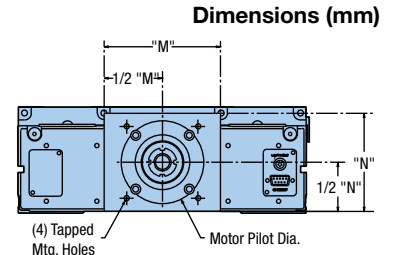
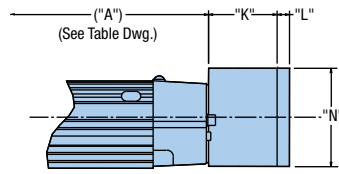

Motor Size	Order Code	K	L	M	N
MPP092	M90	68.0	12.0	115.0	97.0
M105, SMN100	M33	100.0	-	115.0	115.0
NEMA 34	M4	68.0	12.0	115.0	97.0
NEO 34	M17	68.0	12.0	115.0	97.0
NEO 70	M21	68.0	-	115.0	97.0
NEO 92	M29	68.0	12.0	115.0	97.0

Screw Driven Tables

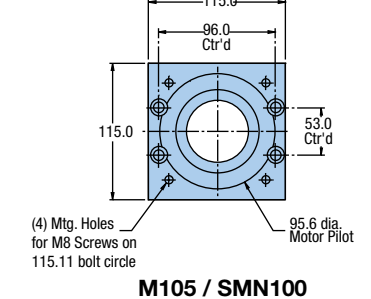
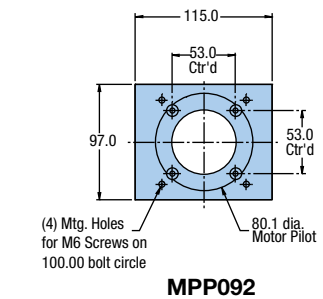
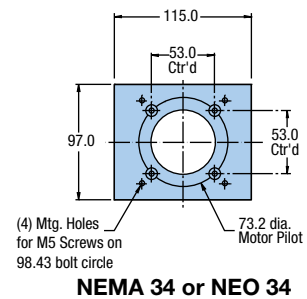
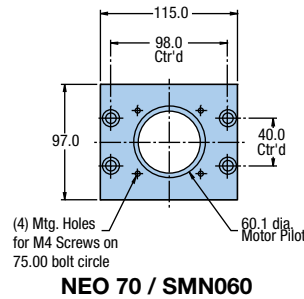

412XR Parallel Motor Mounting

Parallel motor mounting is employed whenever a shorter overall unit length is needed. The motor is positioned along the sides or bottom of the table as designated by position A, B, or C. (No coupling required.)

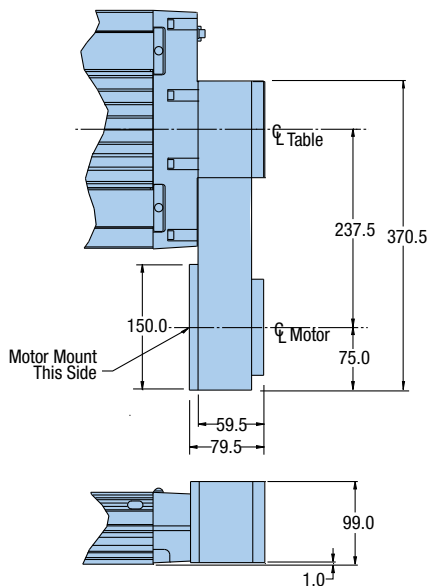

Motor Size	Bolt Circle (mm)	Pilot Ø (mm)	Shaft Ø
MPP092	100.0	80.0	16.0 mm
NEMA 34	98.4	73.2	0.375"
NEO 34	98.4	73.2	0.500"
NEO 70	75.0	60.1	11.0 mm
NEO 92	100.0	80.1	14.0 mm

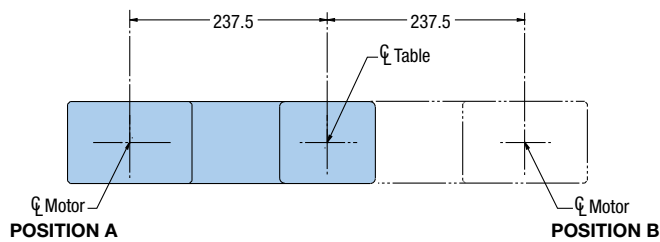

Fill in an order code from each of the numbered fields to create a complete model order code.

	①	②	③	④	⑤	⑥	⑦	⑧	⑨	⑩	⑪	⑫
Order Example:	401	100	XR	M	S	D9	H3	L2	C3	M2	E2	R1
① Series *	401											
② Travel – mm *	050	50										
	100	100										
	150	150										
	200	200										
	300	300										
③ Model	XR	Linear Table										
④ Mounting	M	Metric										
⑤ Grade	S	Standard										
	P	Precision (E3 or E4 encoder option required)										
⑥ Drive Screw *	D3	10 mm Lead										
	D9	2 mm Lead										
⑦ Home Sensor **	H1	None										
	H2	N.C. Current Sinking Flying Leads										
	H3	N.O. Current Sinking Flying Leads										
	H4	N.C. Current Sourcing Flying Leads										
	H5	N.O. Current Sourcing Flying Leads										
	H6	N.C. Current Sinking Locking Connector										
	H7	N.O. Current Sinking Locking Connector										
	H8	N.C. Current Sourcing Locking Connector										
	H9	N.O. Current Sourcing Locking Connector										
	H11	N.C. Current Sinking Sensor Pack										
	H12	N.O. Current Sinking Sensor Pack										
	H13	N.C. Current Sourcing Sensor Pack										
	H14	N.O. Current Sourcing Sensor Pack										
⑧ Limit Sensor **	L1	None										
	L2	N.C. Current Sinking Flying Leads										
	L3	N.O. Current Sinking Flying Leads										
	L4	N.C. Current Sourcing Flying Leads										
	L5	N.O. Current Sourcing Flying Leads										
	L6	N.C. Current Sinking Locking Connector										
	L7	N.O. Current Sinking Locking Connector										
	L8	N.C. Current Sourcing Locking Connector										
	L9	N.O. Current Sourcing Locking Connector										
	L11	N.C. Current Sinking Sensor Pack										
	L12	N.O. Current Sinking Sensor Pack										
	L13	N.C. Current Sourcing Sensor Pack										
	L14	N.O. Current Sourcing Sensor Pack										
⑨ Motor Coupling	C1	No Coupling										
	C2	6.3 mm (0.25 in) Bore Oldham										
	C3	6.3 mm (0.25 in) Bore Bellows										
	C5	9.5 mm (0.375 in) Bore Bellows										
	C24	5 mm (0.20 in) Bore Oldham										
	C25	5 mm (0.20 in) Bore Bellows										
⑩ Motor Mount	M2	SM 16 In-Line Mounting										
	M3	NEMA 23 In-Line Mounting										
	M37	NEMA 17 In-Line Mounting										
	M61	BE 23 In-Line Mounting										
⑪ Encoder Option	E1	None										
	E2	1.0 µm Resolution										
	E3	0.5 µm Resolution										
	E4	0.1 µm Resolution										
⑫ R1	R1	Required Designator										

*** Drive Screw Lead Availability**

Travel	401XR	
	2 mm	10 mm
50	•	
100	•	
150	•	
200		•
300		•

**** 50 mm stroke 401XR may only allow room for 2 sensors in sensor pack.**





Fill in an order code from each of the numbered fields to create a complete model order code.

	①	②	③	④	⑤	⑥	⑦	⑧	⑨	⑩	⑪	⑫
Order Example:	402	100	XR	M	S	D9	H3	L2	C3	M2	E2	R1

- ① **Series ***
402
- ② **Travel – mm ***
100 100
150 150
200 200
300 300
400 400
600 600
- ③ **Model**
XR Linear Table
- ④ **Mounting**
M Metric
- ⑤ **Grade**
S Standard
P Precision (E3 or E4 encoder option required)
- ⑥ **Drive Screw ***
D2 5 mm Lead
D3 10 mm Lead
- ⑦ **Home Sensor**
H1 None
H2 N.C. Current Sinking Flying Leads
H3 N.O. Current Sinking Flying Leads
H4 N.C. Current Sourcing Flying Leads
H5 N.O. Current Sourcing Flying Leads
H6 N.C. Current Sinking Locking Connector
H7 N.O. Current Sinking Locking Connector
H8 N.C. Current Sourcing Locking Connector
H9 N.O. Current Sourcing Locking Connector
H11 N.C. Current Sinking Sensor Pack
H12 N.O. Current Sinking Sensor Pack
H13 N.C. Current Sourcing Sensor Pack
H14 N.O. Current Sourcing Sensor Pack

- ⑧ **Limit Sensor**
L1 None
L2 N.C. Current Sinking Flying Leads
L3 N.O. Current Sinking Flying Leads
L4 N.C. Current Sourcing Flying Leads
L5 N.O. Current Sourcing Flying Leads
L6 N.C. Current Sinking Locking Connector
L7 N.O. Current Sinking Locking Connector
L8 N.C. Current Sourcing Locking Connector
L9 N.O. Current Sourcing Locking Connector
L11 N.C. Current Sinking Sensor Pack
L12 N.O. Current Sinking Sensor Pack
L13 N.C. Current Sourcing Sensor Pack
L14 N.O. Current Sourcing Sensor Pack
- ⑨ **Motor Coupling**
C1 No Coupling
C2 6.3 mm (0.25 in) Bore Oldham
C3 6.3 mm (0.25 in) Bore Bellows
C4 9.5 mm (0.375 in) Bore Oldham*
C5 9.5 mm (0.375 in) Bore Bellows
C24 5 mm (0.20 in) Bore Oldham
C25 5 mm (0.20 in) Bore Bellows
*NEMA 23 frame size only (M3, M61)
- ⑩ **Motor Mount**
M2 SM 16 In-Line Mounting
M3 NEMA 23 In-Line Mounting
M37 NEMA 17 In-Line Mounting
M61 BE 23 In-Line Mounting
- ⑪ **Encoder Option**
E1 None
E2 1.0 µm Resolution
E3 0.5 µm Resolution
E4 0.1 µm Resolution
- ⑫ **R1** Required Designator

Screw Driven Tables

*** Drive Screw Lead Availability**

Travel	402XR	
	5 mm	10 mm
100	•	
150	•	
200	•	
300		•
400		•
600		•



Fill in an order code from each of the numbered fields to create a complete model order code.

	①	②	③	④	⑤	⑥	⑦	⑧	⑨	⑩	⑪	⑫	⑬	⑭
Order Example:	404	450	XR	M	S	- D33	H4	L2	C3	M4	E1	B1	R1	P1

<p>① Series 404</p>	<p>② Travel – mm * 050 50 (no pinning available) 100 100 150 150 200 200 250 250 300 300 350 350 400 400 450 450 500 500 550 550 600 600</p>	<p>③ Model XR Linear Table</p>	<p>④ Mounting M Metric</p>	<p>⑤ Grade S Standard P Precision (only available with D2, D3, D4 drive screws)</p>	<p>⑥ Drive Screw D1 Free Travel D2 5 mm Ballscrew D3 10 mm Ballscrew D4 20 mm Ballscrew (standard grade only) D31 1 mm V Thread Leadscrew D32 2 mm V Thread Leadscrew D33 5 mm V Thread Leadscrew D34 0.10" V Thread Leadscrew D35 0.10" Acme Thread Leadscrew</p>	<p>⑦ Home Sensor Assembly (one sensor) H1 None-Free Travel (only) H2 N.C. Current Sinking Flying Leads H3 N.O. Current Sinking Flying Leads H4 N.C. Current Sourcing Flying Leads H5 N.O. Current Sourcing Flying Leads H6 N.C. Current Sinking Locking Connector* H7 N.O. Current Sinking Locking Connector*</p>	<p>H8 N.C. Current Sourcing Locking Connector* H9 N.O. Current Sourcing Locking Connector* H11 N.C. Current Sinking Sensor Pack** H12 N.O. Current Sinking Sensor Pack** H13 N.C. Current Sourcing Sensor Pack** H14 N.O. Current Sourcing Sensor Pack**</p>	<p>⑧ Travel Limit Sensor Assembly (two sensors) L1 None-Free Travel (only) L2 N.C. Current Sinking Flying Leads L3 N.O. Current Sinking Flying Leads L4 N.C. Current Sourcing Flying Leads L5 N.O. Current Sourcing Flying Leads L6 N.C. Current Sinking w/Locking Connector* L7 N.O. Current Sinking w/Locking Connector* L8 N.C. Current Sourcing w/Locking Connector* L9 N.O. Current Sourcing w/Locking Connector* L11 N.C. Current Sinking Sensor Pack** L12 N.O. Current Sinking Sensor Pack** L13 N.C. Current Sourcing Sensor Pack** L14 N.O. Current Sourcing Sensor Pack**</p>	<p>⑨ Motor Coupling C1 No Coupling (required for parallel mounting) C2 0.250" Oldham C3 0.250" Bellows (required for precision grade) C4 0.375" Oldham C5 0.375" Bellows (required for precision grade) C6 11 mm Oldham C7 11 mm Bellows (required for precision grade) C10 14 mm Oldham (M75 motor option) C11 14 mm Bellows (M75 motor option) C22 9 mm Oldham C23 9 mm Bellows C24 5 mm Oldham (M37 motor option) C25 5 mm Bellows (M37 motor option) C26 8 mm Oldham (M71 motor option) C27 8 mm Bellows (M71 motor option) C28 0.1875" Oldham (M37 motor option) C29 0.1875" Bellows (M37 motor option) C30 0.250" Oldham (couplings for leadscrew grade) C31 0.250" Bellows (couplings for leadscrew grade) C32 0.375" Oldham (couplings for leadscrew grade) C33 0.375" Bellows (couplings for leadscrew grade) C39 9 mm Bellows (couplings for leadscrew grade)</p>
--------------------------------	---	---	---------------------------------------	--	---	--	--	---	--

* Sensors with locking connector include 5 m extension cable.
** Sensor Pack includes 3 m cable.





⑩ Motor Mount *

M1	No Motor Mount
M2	SM 16 In-Line Mounting
M3	NEMA 23 & SM 23 In-Line Mounting
M4	NEMA 34 In-Line Mounting
M5	SM 16 Parallel Mounting, "A" Location*
M6	SM 16 Parallel Mounting, "B" Location*
M7	SM 16 Parallel Mounting, "C" Location*
M8	NEMA 23 Parallel Mounting, "A" Location*
M9	NEMA 23 Parallel Mounting, "B" Location*
M10	NEMA 23 Parallel Mounting, "C" Location*
M11	SM 23 Parallel Mounting, "A" Location*
M12	SM 23 Parallel Mounting, "B" Location*
M13	SM 23 Parallel Mounting, "C" Location*
M21	Neometric 70 In-Line Mounting
M37	NEMA 17 In-Line Mounting
M42	SM232AQ NPSN Servo Motor In-Line Mounting
M46	HV232-02-10 Stepper Motor In-Line Mounting
M49	Handcrank without Readout
M50	Handcrank with Readout (0.10" or 1 mm leads only)
M61	BE 23 In-Line Mounting
M62	BE 23 Parallel Mounting, "A" Location*
M63	BE 23 Parallel Mounting, "B" Location*
M64	BE 23 Parallel Mounting, "C" Location*
M71	SGM01 In-Line Mounting
M75	SGM02 In-Line Mounting

* See 404XR dimensions for maximum allowable motor shaft diameter. Parallel motor mounts not available with leadscrew drives.

⑪ Encoder Option

E1	No Encoder
E2	1.0 μm Resolution Linear Encoder (tape scale)
E3	0.5 μm Resolution Linear Encoder (tape scale)
E4	0.1 μm Resolution Linear Encoder (tape scale)
E5	Rotary Shaft Encoder (not available with brake)

⑫ Brake Option

B1	No Brake
B2	Shaft Brake (Refer to 404XR holding torque specifications to confirm maximum load. Not available with rotary encoder)

⑬ Cleanroom Preparation

R1	Class 1000 Compatible
R2	Class 10 Compatible (consult factory)
R5	Class 1000 with Easy Lube System
R8	Class 10 with Easy Lube System

⑭ Pinning Option *

P1	No multi-axis pinning
P2	X axis transfer pinning to Y or Z axis - 30 arc-sec **
P3	Y axis transfer pinning to X axis - 30 arc-sec
P4	Z axis transfer pinning to X axis - 30 arc-sec
P5	X axis transfer pinning to Y axis - 125 arc-sec
P6	Y axis transfer pinning to X axis - 125 arc-sec

* Pinning option is for pinning to other 404XR and 406XR tables. Transfer pinning is not available on some XR to LXR models. Contact factory for more information. Pinning XY orientation standard with Y motor at 3 o'clock position.

** Z pinning uses bracket (see figures 7, 8 and 9 on page 47)

Fill in an order code from each of the numbered fields to create a complete model order code.

	①	②	③	④	⑤	⑥	⑦	⑧	⑨	⑩	⑪	⑫	⑬	⑭	
Order Example:	406	900	XR	M	S	-	D3	H4	L1	C7	M4	E1	B1	R1	P1

- ① **Series**
406
- ② **Travel – mm ***
100 100
200 200
300 300
400 400
500 500
600 600
700 700
800 800
900 900
1000 1000
1250 1250
1500 1500
1750 1750
2000 2000

- ③ **Model**
XR Linear Table

- ④ **Mounting**
M Metric

- ⑤ **Grade ***
S Standard
P Precision

- ⑥ **Drive Screw ***
D1 Free Travel
D2 5 mm Ballscrew
D3 10 mm Ballscrew
D4 20 mm Ballscrew
D5 25 mm Ballscrew

- ⑦ **Home Sensor Assembly (one sensor)**
H1 None
H2 N.C. Current Sinking Flying Leads
H3 N.O. Current Sinking Flying Leads
H4 N.C. Current Sourcing Flying Leads
H5 N.O. Current Sourcing Flying Leads
H6 N.C. Current Sinking Locking Connector**
H7 N.O. Current Sinking Locking Connector**
H8 N.C. Current Sourcing Locking Connector**
H9 N.O. Current Sourcing Locking Connector**
H11 N.C. Current Sinking Sensor Pack***
H12 N.O. Current Sinking Sensor Pack***
H13 N.C. Current Sourcing Sensor Pack***
H14 N.O. Current Sourcing Sensor Pack***

- ⑧ **Travel Limit Sensor Assembly (two sensors)**
L1 None
L2 N.C. Current Sinking Flying Leads
L3 N.O. Current Sinking Flying Leads
L4 N.C. Current Sourcing Flying Leads
L5 N.O. Current Sourcing Flying Leads
L6 N.C. Current Sinking w/Locking Connector**
L7 N.O. Current Sinking w/Locking Connector**
L8 N.C. Current Sourcing w/Locking Connector**
L9 N.O. Current Sourcing w/Locking Connector**
L11 N.C. Current Sinking Sensor Pack ***
L12 N.O. Current Sinking Sensor Pack***
L13 N.C. Current Sourcing Sensor Pack***
L14 N.O. Current Sourcing Sensor Pack ***

- ⑨ **Motor Coupling**
C1 No Coupling (required for parallel mounting)
C2 0.250" Oldham
C3 0.250" Bellows (required for precision grade)
C4 0.375" Oldham
C5 0.375" Bellows (required for precision grade)
C6 11 mm Oldham
C7 11 mm Bellows (required for precision grade)
C8 0.500" Oldham
C9 0.500" Bellows (required for precision grade)
C10 14 mm Oldham
C11 14 mm Bellows (required for precision grade)
C12 16 mm Oldham
C13 16 mm Bellows (required for precision grade)

*** Drive Screw Lead Availability**

Travel	Precision Grade		Standard Grade			
	5 mm	10 mm	5 mm	10 mm	20 mm	25 mm
100	•	•	•	•	•	
200	•	•	•	•	•	
400	•	•	•	•	•	
400	•	•	•	•	•	
500	•	•	•	•	•	
600	•	•	•	•	•	
700			•	•		•
800			•	•		•
900			•	•		•
1000			•	•		•
1250			•	•		•
1500			•	•		•
1750			•	•		•
2000			•	•		•

** Sensors with locking connector include 5 m extension cable.
*** Sensor Pack includes 3 m cable.





⑩ Motor Mount *

M1	No Motor Mount
M3	NEMA 23 & SM 23 In-Line Mounting
M4	NEMA 34 In-Line Mounting
M11	SM 23 Parallel Mounting, "A" Location*
M12	SM 23 Parallel Mounting, "B" Location*
M13	SM 23 Parallel Mounting, "C" Location*
M14	NEMA 34 Parallel Mounting, "A" Location
M15	NEMA 34 Parallel Mounting, "B" Location
M16	NEMA 34 Parallel Mounting, "C" Location
M17	Neometric 34 In-Line Mounting
M18	Neometric 34 Parallel Mounting, "A" Location
M19	Neometric 34 Parallel Mounting, "B" Location
M20	Neometric 34 Parallel Mounting, "C" Location
M21	Neometric 70 In-Line Mounting
M22	Neometric 70 Parallel Mounting, "A" Location
M23	Neometric 70 Parallel Mounting, "B" Location
M25	Neometric 70 Parallel Mounting, "C" Location
M29	Neometric 92 In-Line Mounting
M61	BE 23 In-Line Mounting
M62	BE 23 Parallel Mounting, "A" Location
M63	BE 23 Parallel Mounting, "B" Location
M64	BE 23 Parallel Mounting, "C" Location
M75	SGM02 In-Line Mounting
M90	MPP092 In-Line Mounting
M91	MPP092 Parallel Mounting, "A" Location
M92	MPP092 Parallel Mounting, "B" Location
M93	MPP092 Parallel Mounting, "C" Location

* See 406XR dimensions for maximum allowable motor shaft diameter. SM 23 parallel motor mounts not available with leadscrew drives.

⑪ Encoder Option

E1	No Encoder
E2	1.0 μm Resolution Linear Encoder (tape scale)
E3	0.5 μm Resolution Linear Encoder (tape scale)
E4	0.1 μm Resolution Linear Encoder (tape scale)
E5	Rotary Shaft Encoder (not available with brake)

⑫ Brake Option

B1	No Brake
B2	Shaft Brake (Refer to 406XR holding torque specifications to confirm maximum load. Not available with rotary encoder)

⑬ Cleanroom Preparation

R1	Class 1000 Compatible
R2	Class 10 Compatible (consult factory)
R5	Class 1000 with Easy Lube System
R8	Class 10 with Easy Lube System

⑭ Pinning Option *

P1	No multi-axis pinning
P2	X axis transfer pinning to Y or Z axis - 30 arc-sec **
P3	Y axis transfer pinning to X axis - 30 arc-sec
P4	Z axis transfer pinning to X axis - 30 arc-sec

* Pinning option is for pinning to other 404XR and 406XR tables. Transfer pinning is not available on some XR to LXR models. Contact factory for more information. Pinning XY orientation standard with Y motor at 3 o'clock position.

** Z pinning uses bracket (see figures 7, 8 and 9 on page 47)

Fill in an order code from each of the numbered fields to create a complete model order code.

① ② ③ ④ ⑤ ⑥ ⑦ ⑧ ⑨ ⑩ ⑪ ⑫ ⑬ ⑭

Order Example:	412	T03	XR	M	S -	D2	H3	L3	C15	M4	E3	B1	R1	P1
-----------------------	-----	-----	----	---	-----	----	----	----	-----	----	----	----	----	----

① **Series**

412

② **Travel – mm**

T01	150
T02	250
T03	350
T04	650
T05	800
T06	1000
T07	1200
T08	1500
T09	1750
T10	2000

③ **Model**

XR Linear Table

④ **Mounting**

M Metric

⑤ **Grade**

S Standard

⑥ **Drive Screw**

D1	Free Travel
D2	5 mm Leadscrew
D3	10 mm Leadscrew
D5	25 mm Leadscrew
D6	32 mm Leadscrew

⑦ **Home Sensor ***

H1	None
H2	N.C. Current Sinking Flying Leads
H3	N.O. Current Sinking Flying Leads
H4	N.C. Current Sourcing Flying Leads
H5	N.O. Current Sourcing Flying Leads

* Includes a 3 meter extension cable with flying lead termination. A 7.5 meter extension cable can be ordered separately.

⑧ **Travel Limit Sensor ***

L1	None
L2	N.C. Current Sinking Flying Leads
L3	N.O. Current Sinking Flying Leads
L4	N.C. Current Sourcing Flying Leads
L5	N.O. Current Sourcing Flying Leads

* Includes a 3 meter extension cable with flying lead termination. A 7.5 meter extension cable can be ordered separately.

⑨ **Motor Coupling**

C1	No Coupling
C4	0.375" Oldham
C5	0.375" Bellows
C6	11 mm Oldham
C7	11 mm Bellows
C8	0.500" Oldham
C9	0.500" Bellows
C10	14 mm Oldham
C11	14 mm Bellows
C12	16 mm Oldham
C13	16 mm Bellows
C14	0.750" (19 mm) Oldham
C15	0.750" (19 mm) Bellows



⑩ Motor Mount

M1	No Motor Mount
M4	NEMA 34 In-Line Mounting
M14	NEMA 34 Parallel Mounting, "A" Location
M15	NEMA 34 Parallel Mounting, "B" Location
M17	Neometric 34 In-Line Mounting
M18	Neometric 34 Parallel Mounting, "A" Location
M19	Neometric 34 Parallel Mounting, "B" Location
M21	Neometric 70 In-Line Mounting
M22	Neometric 70 Parallel Mounting, "A" Location
M23	Neometric 70 Parallel Mounting, "B" Location
M29	Neometric 92 In-Line Mounting
M30	Neometric 92 Parallel Mounting, "A" Location
M31	Neometric 92 Parallel Mounting, "B" Location
M33	M105 & SMN100 In-Line Mounting
M90	MPP092 In-Line Mounting
M91	MPP092 Parallel Mounting, "A" Location
M92	MPP092 Parallel Mounting, "B" Location
M93	MPP092 Parallel Mounting, "C" Location

⑪ Encoder Option

E1	No Encoder
E2	1.0 μ m Resolution Linear Encoder (tape scale)
E3	0.5 μ m Resolution Linear Encoder (tape scale)
E4	0.1 μ m Resolution Linear Encoder (tape scale)
E5	5.0 μ m Resolution Linear Encoder (tape scale)
E6	Rotary Shaft Encoder (not available with brake)
E7	Sine Encoder

⑫ Brake Option

B1	No Brake
B2	Shaft Brake (Refer to 412XR holding torque specifications to confirm maximum load. Not available with rotary encoder)

⑬ Cleanroom Preparation

R1	Class 1000 with Strip Seals
R2	Class 100 without Strip Seals

⑭ Pinning Option *

P1	No multi-axis pinning
P2	X axis transfer pinning to Y or Z axis - 30 arc-sec **
P3	Y axis transfer pinning to X axis - 30 arc-sec (includes a required 15 mm thick adapter)
P4	Z axis transfer pinning to X axis - 30 arc-sec

* Pinning option is for pinning to other 404XR and 406XR tables. Transfer pinning is not available on some XR to LXR models. Contact factory for more information. Pinning XY orientation standard with Y motor at 3 o'clock position.

** Z pinning uses bracket (see figures 7, 8 and 9 on page 47)

XRS Cartesian Systems

Parker XRS Series “standard” Cartesian robot modules are the ideal solution for cost effective automation in life sciences, semiconductor, electronics, automated assembly, dispensing, and many other applications.

Standard XRS Systems are pre-engineered to optimize work-space, simplify selection, shorten delivery and lower costs.

Scalability

With 3 size platforms and 124 standard systems you can find a standard solution for your application.

Technology

A unique mix of linear servo motor and ballscrew drive technology provides optimized dynamic performance for today’s demanding automation applications.

Reliability

XRS Systems are built from Parker’s XR/LXR linear positioners, time tested and proven in thousands of applications worldwide.

- Pre-engineered cost-effective automation package
- Performance matched components
- Protection from environment
- Cleanroom preparation available

- Innovative strip seal design provides IP30 protection to interior components as well as enhanced overall appearance
- Inertia matched brushless servo motors provide compatibility with Parker and other industry standard drives and controls
- Pre-installed air, power and signal lines routed to moving payload for convenient hook-up and long life operation
- System cable management features “high-flex” shielded cables with quick disconnect convenience
- Precision dowel holes in carriage surface allows repeatable mounting of tooling to robot.
- Precision dowel holes in base allows repeatable mounting of entire robot module into machine
- Cleanroom preparation and other options are available for easy selection

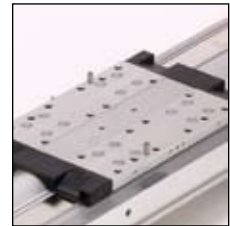

Small Platform XRS Cartesian Systems

- Smaller footprint for light loads and shorter travels
- Maximum X-Y work area: 600 mm X 300 mm
- Maximum load: 5 kg
- Recommended Parker Servo Drive:
X axis: AR-02_E
Y axis: AR-02_E
Z axis: AR-02_E



Ordering Information:

Specify the system number corresponding to the appropriate orientation and performance characteristics.

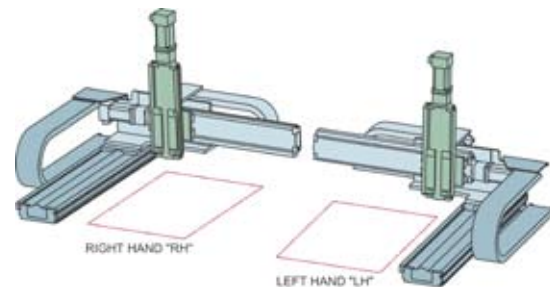

Right Hand System Number	Left Hand System Number	Max. Load (kg)	Work Envelope (mm)			Velocity (mm/sec)			Resolution (µm)			Repeatability* (µm)		
			X	Y	Z	X	Y	Z	X	Y	Z	X	Y	Z
XRS-0001	XRS-0009	5	300	300	–	600	700	–	2.5	2.5	–	16	15	–
XRS-0002	XRS-0010	5	300	300	100	600	700	140	2.5	2.5	0.5	16	15	10
XRS-0003	XRS-0011	5	600	300	–	600	700	–	2.5	2.5	–	16	15	–
XRS-0004	XRS-0012	5	600	300	100	500	700	140	2.5	2.5	0.5	16	15	10
XRS-0005	XRS-0013	5	300	300	–	1500	700	–	1	2.5	–	16	15	–
XRS-0006	XRS-0014	5	300	300	100	1500	700	140	1	2.5	0.5	16	15	10
XRS-0007	XRS-0015	5	600	300	–	2250	700	–	1	2.5	–	16	15	–
XRS-0008	XRS-0016	5	600	300	100	2250	700	140	1	2.5	0.5	16	15	10

* Repeatability established at maximum load - fully extended stroke.

Linear Motor driven actuator

Ballscrew driven actuator





Medium Platform XRS Cartesian Systems

- For mid-range loads and travels
- Maximum X-Y work area: 1000 mm X 600 mm
- Maximum load: 12 kg
- Recommended Parker Servo Drive:
 X axis: AR-04_E
 Y axis: AR-02_E
 Z axis: AR-02_E

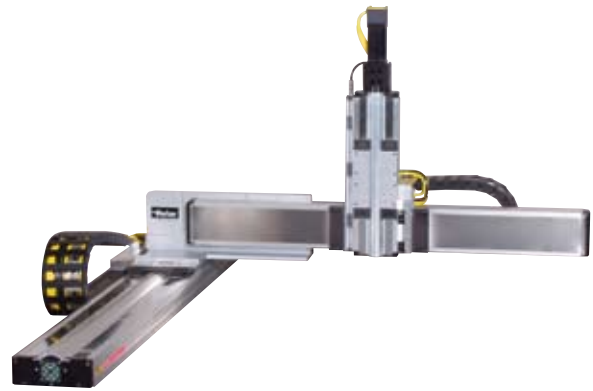

Screw Driven Tables

Right Hand System Number	Left Hand System Number	Max. Load (kg)	Work Envelope (mm)			Velocity (mm/sec)			Resolution (µm)			Repeatability** (µm)		
			X	Y	Z	X	Y	Z	X	Y	Z	X	Y	Z
XRS-0017	XRS-0053	12	600	400	–	500	600	–	2.5	2.5	–	45	7	–
XRS-0018	XRS-0054	5	600	400	100	500	600	140	2.5	2.5	0.5	45	7	10
XRS-0019	XRS-0055	12	600	400	150	500	600	600	2.5	2.5	2.5	45	7	6
XRS-0020*	XRS-0056*	12	600	400	150	500	600	600	2.5	2.5	2.5	45	7	6
XRS-0021	XRS-0057	12	600	600	–	500	500	–	2.5	2.5	–	45	7	–
XRS-0022	XRS-0058	5	600	600	100	500	500	140	2.5	2.5	0.5	45	7	10
XRS-0023	XRS-0059	12	600	600	150	500	500	600	2.5	2.5	2.5	45	7	6
XRS-0024*	XRS-0060*	12	600	600	150	500	500	600	2.5	2.5	2.5	45	7	6
XRS-0025	XRS-0061	12	1000	600	–	350	500	–	2.5	2.5	–	45	7	–
XRS-0026	XRS-0062	5	1000	600	100	350	500	140	2.5	2.5	0.5	45	7	10
XRS-0027	XRS-0063	12	1000	600	150	350	500	600	2.5	2.5	2.5	45	7	6
XRS-0028*	XRS-0064*	12	1000	600	150	350	500	600	2.5	2.5	2.5	45	7	6
XRS-0029	XRS-0065	12	600	400	–	500	2000	–	2.5	1	–	45	5	–
XRS-0030	XRS-0066	5	600	400	100	500	2000	140	2.5	1	0.5	45	5	10
XRS-0031	XRS-0067	12	600	400	150	500	2000	600	2.5	1	2.5	45	5	6
XRS-0032*	XRS-0068*	12	600	400	150	500	2000	600	2.5	1	2.5	45	5	6
XRS-0033	XRS-0069	12	600	600	–	500	2000	–	2.5	1	–	45	5	–
XRS-0034	XRS-0070	5	600	600	100	500	2000	140	2.5	1	0.5	45	5	10
XRS-0035	XRS-0071	12	600	600	150	500	2000	600	2.5	1	2.5	45	5	6
XRS-0036*	XRS-0072*	12	600	600	150	500	2000	600	2.5	1	2.5	45	5	6
XRS-0037	XRS-0073	12	1000	600	–	350	2000	–	2.5	1	–	45	5	–
XRS-0038	XRS-0074	5	1000	600	100	350	2000	140	2.5	1	0.5	45	5	10
XRS-0039	XRS-0075	12	1000	600	150	350	2000	600	2.5	1	2.5	45	5	6
XRS-0040*	XRS-0076*	12	1000	600	150	350	2000	600	2.5	1	2.5	45	5	6
XRS-0041	XRS-0077	12	650	400	–	2000	2000	–	1	1	–	45	5	–
XRS-0042	XRS-0078	5	650	400	100	2000	2000	140	1	1	0.5	45	5	10
XRS-0043	XRS-0079	12	650	400	150	2000	2000	600	1	1	2.5	45	5	6
XRS-0044*	XRS-0080*	12	650	400	150	2000	2000	600	1	1	2.5	45	5	6
XRS-0045	XRS-0081	12	650	600	–	2000	2000	–	1	1	–	45	5	–
XRS-0046	XRS-0082	5	650	600	100	2000	2000	140	1	1	0.5	45	5	10
XRS-0047	XRS-0083	12	650	600	150	2000	2000	600	1	1	2.5	45	5	6
XRS-0048*	XRS-0084*	12	650	600	150	2000	2000	600	1	1	2.5	45	5	6
XRS-0049	XRS-0085	12	850	600	–	2000	2000	–	1	1	–	45	5	–
XRS-0050	XRS-0086	5	850	600	100	2000	2000	140	1	1	0.5	45	5	10
XRS-0051	XRS-0087	12	850	600	150	2000	2000	600	1	1	2.5	45	5	6
XRS-0052*	XRS-0088*	12	850	600	150	2000	2000	600	1	1	2.5	45	5	6

* Models indicated have the Z-axis mounted to the Y-axis "carriage to carriage", hence the Z-axis will extend & retract vertically. Note that the F dimension (see dimensions on facing page), is established when the Z-axis is at the top of the stroke.

** Repeatability is established at maximum load - fully extended stroke. Linear Motor driven actuator Ballscrew driven actuator

Large Platform XRS Cartesian Systems

- For heavier loads and travels
- Maximum X-Y work area: 1000 mm X 1000 mm
- Maximum load: 25 kg
- Recommended Parker Servo Drive:
 X axis: AR-08_E
 Y axis: AR-04_E
 Z axis: AR-02_E



Right Hand System Number	Left Hand System Number	Max. Load (kg)	Work Envelope (mm)			Velocity (mm/sec)			Resolution (µm)			Repeatability** (µm)		
			X	Y	Z	X	Y	Z	X	Y	Z	X	Y	Z
XRS-0089	XRS-0107	25	650	600	-	470	500	-	2.5	2.5	-	50	7	-
XRS-0090	XRS-0108	25	650	600	150	470	500	600	2.5	2.5	2.5	50	7	6
XRS-0091*	XRS-0109*	25	650	600	150	470	500	600	2.5	2.5	2.5	50	7	6
XRS-0092	XRS-0110	25	1000	600	-	450	500	-	2.5	2.5	-	50	7	-
XRS-0093	XRS-0111	25	1000	600	150	450	500	600	2.5	2.5	2.5	50	7	6
XRS-0094*	XRS-0112*	25	1000	600	150	450	500	600	2.5	2.5	2.5	50	7	6
XRS-0095	XRS-0113	25	1000	1000	-	450	350	-	2.5	2.5	-	50	7	-
XRS-0096	XRS-0114	25	1000	1000	150	450	350	600	2.5	2.5	2.5	50	7	6
XRS-0097*	XRS-0115*	25	1000	1000	150	450	350	600	2.5	2.5	2.5	50	7	6
XRS-0098	XRS-0116	25	650	650	-	2000	2000	-	1	1	-	50	7	-
XRS-0099	XRS-0117	25	650	650	150	2000	2000	600	1	1	2.5	50	7	6
XRS-0100*	XRS-0118*	25	650	650	150	2000	2000	600	1	1	2.5	50	7	6
XRS-0101	XRS-0119	25	1000	650	-	2000	2000	-	1	1	-	50	7	-
XRS-0102	XRS-0120	25	1000	650	150	2000	2000	600	1	1	2.5	50	7	6
XRS-0103*	XRS-0121*	25	1000	650	150	2000	2000	600	1	1	2.5	50	7	6
XRS-0104	XRS-0122	25	1000	850	-	2000	2000	-	1	1	-	50	7	-
XRS-0105	XRS-0123	25	1000	850	150	2000	2000	600	1	1	2.5	50	7	6
XRS-0106*	XRS-0124*	25	1000	850	150	2000	2000	600	1	1	2.5	50	7	6

* Models indicated have the Z-axis mounted to the Y-axis "carriage to carriage", hence the Z-axis will extend & retract vertically. Note that the F dimension (see dimensions on facing page), is established when the Z-axis is at the top of the stroke.

** Repeatability is established at maximum load - fully extended stroke. Linear Motor driven actuator Ballscrew driven actuator



Small Platform Dimensions

Dimensions (mm)

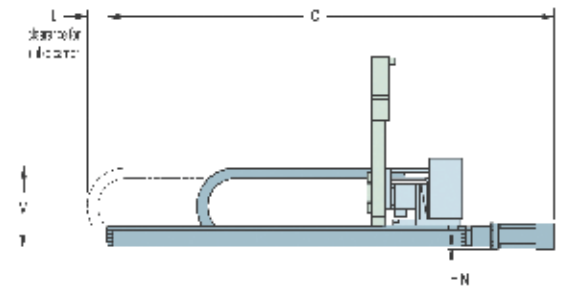
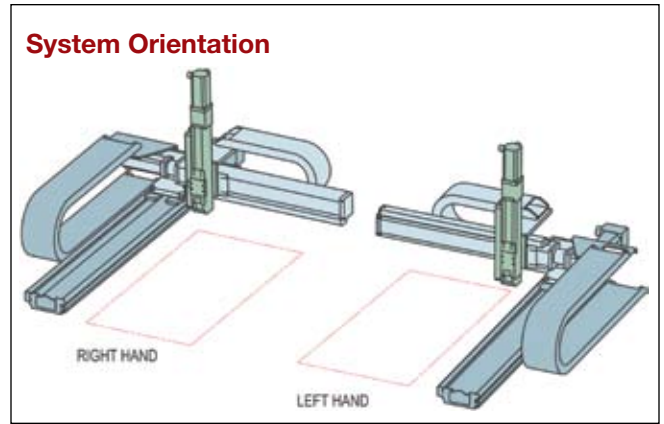
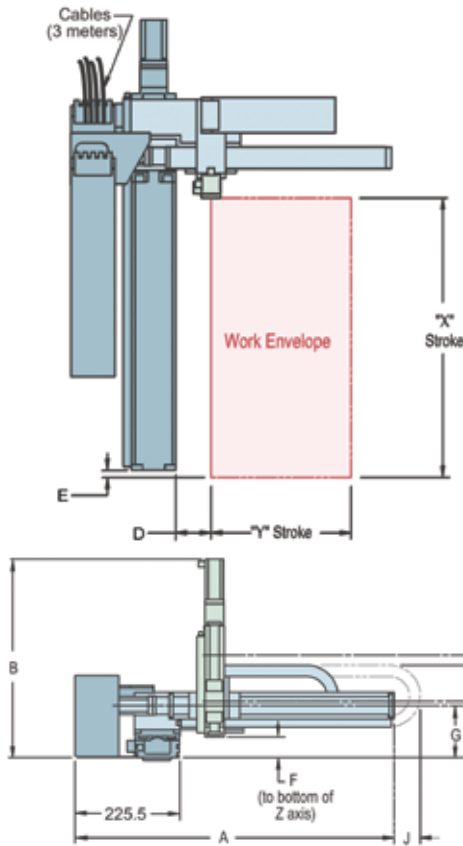

Screw Driven Tables

Right Hand System Number	Left Hand System Number	Dimensions (mm)															
		A	B	C	D	E	F	G	H	J	K	L	M	N	X	Y	Z
XRS-0001	XRS-0009	688.0	-	707.1	75.5	-27.7	-	112.0	-	35	198.7	50	198	6	300	300	-
XRS-0002	XRS-0010	688.0	463.4	707.1	75.5	15.3	46.7	112.0	120	35	198.7	50	198	6	300	300	100
XRS-0003	XRS-0011	688.0	-	1000.1	75.5	-27.7	-	112.0	-	35	198.7	50	198	6	600	300	-
XRS-0004	XRS-0012	688.0	463.4	1000.1	75.5	15.3	46.7	112.0	120	35	198.7	50	198	6	600	300	100
XRS-0005	XRS-0013	689.5	-	596.0	74.0	-71.2	-	124.7	-	35	211.5	50	211	-	300	300	-
XRS-0006	XRS-0014	689.5	476.1	596.0	74.0	-28.3	59.5	124.7	133	35	211.5	50	211	-	600	300	100
XRS-0007	XRS-0015	689.5	-	896.0	74.0	-71.2	-	124.7	-	35	211.5	50	211	-	300	300	-
XRS-0008	XRS-0016	689.5	476.1	896.0	74.0	-28.3	59.5	124.7	133	35	211.5	50	211	-	600	300	100

Medium Platform Dimensions

Dimensions (mm)

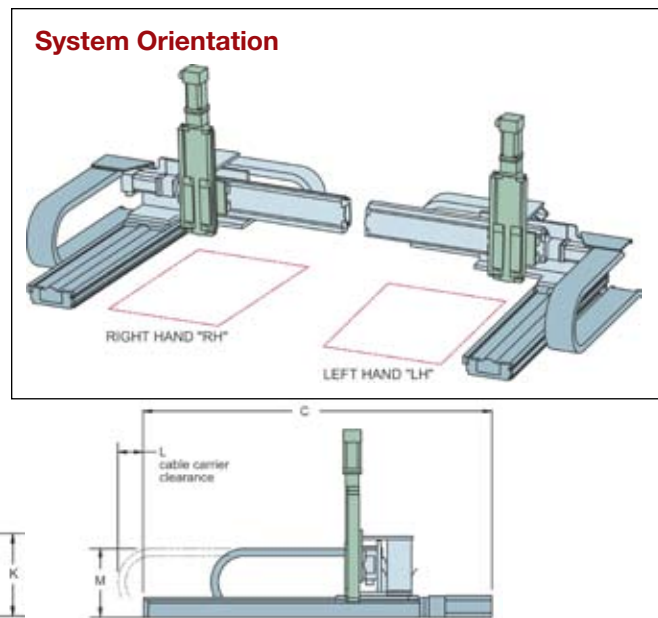
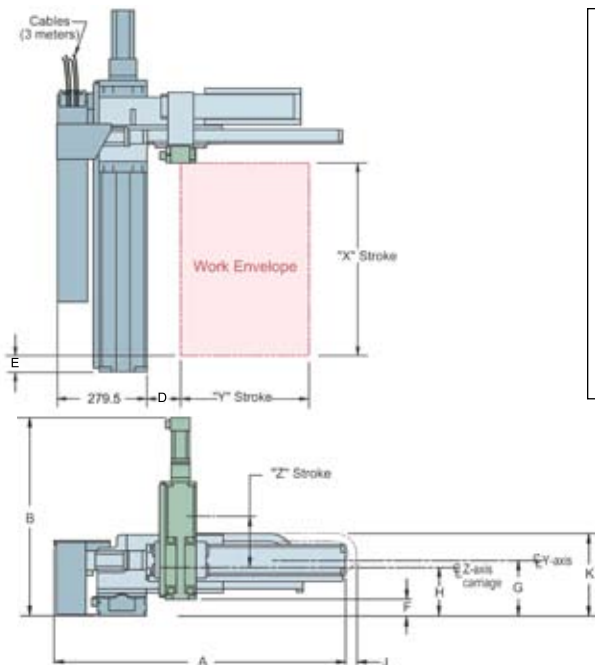

Right Hand System Number	Left Hand System Number	Dimensions (mm)														
		A	B	C	D	E	F	G	H	J	K	L	M	X	Y	Z
XRS-0017	XRS-0053	892.5	-	1127.5	105	-99.0	-	170.1	-	60	261	80	225	600	400	-
XRS-0018	XRS-0054	892.5	530.8	1127.5	105	-56.0	82.6	170.1	156	60	261	80	225	600	400	100
XRS-0019	XRS-0055	892.5	646.0	1127.5	105	-51.7	64.1	170.1	170	60	261	80	225	600	400	150
XRS-0020*	XRS-0056*	892.5	646.0	1127.5	105	-51.7	64.6*	170.1	170	60	261	80	225	600	400	150
XRS-0021	XRS-0057	1092.5	-	1127.5	105	-99.0	-	170.1	-	60	261	80	225	600	600	-
XRS-0022	XRS-0058	1092.5	530.8	1127.5	105	-56.0	82.6	170.1	156	60	261	80	225	600	600	100
XRS-0023	XRS-0059	1092.5	646.0	1127.5	105	-51.7	64.1	170.1	170	60	261	80	225	600	600	150
XRS-0024*	XRS-0060*	1092.5	646.0	1127.5	105	-51.7	64.6*	170.1	170	60	261	80	225	600	600	150
XRS-0025	XRS-0061	1092.5	-	1527.5	105	-99.0	-	170.1	-	60	261	80	225	1000	600	-
XRS-0026	XRS-0062	1092.5	530.8	1527.5	105	-56.0	82.6	170.1	156	60	261	80	225	1000	600	100
XRS-0027	XRS-0063	1092.5	646.0	1527.5	105	-51.7	64.1	170.1	170	60	261	80	225	1000	600	150
XRS-0028*	XRS-0064*	1092.5	646.0	1527.5	105	-51.7	64.6*	170.1	170	60	261	80	225	1000	600	150
XRS-0029	XRS-0065	934.5	-	1127.5	105	-86.3	-	170.1	-	30	281	80	225	600	400	-
XRS-0030	XRS-0066	934.5	530.8	1127.5	105	-43.4	82.6	170.1	156	30	281	80	225	600	400	100
XRS-0031	XRS-0067	934.5	646.0	1127.5	105	-39.0	64.1	170.1	170	30	281	80	225	600	400	150
XRS-0032*	XRS-0068*	934.5	646.0	1127.5	105	-39.0	64.6*	170.1	170	30	281	80	225	600	400	150
XRS-0033	XRS-0069	1134.5	-	1127.5	105	-86.3	-	170.1	-	30	281	80	225	600	600	-
XRS-0034	XRS-0070	1134.5	530.8	1127.5	105	-43.4	82.6	170.1	156	30	281	80	225	600	600	100
XRS-0035	XRS-0071	1134.5	646.0	1127.5	105	-39.0	64.1	170.1	170	30	281	80	225	600	600	150
XRS-0036*	XRS-0072*	1134.5	646.0	1127.5	105	-39.0	64.6*	170.1	170	30	281	80	225	600	600	150
XRS-0037	XRS-0073	1134.5	-	1527.5	105	-86.3	-	170.1	-	30	281	80	225	1000	600	-
XRS-0038	XRS-0074	1134.5	530.8	1527.5	105	-43.4	82.6	170.1	156	30	281	80	225	1000	600	100
XRS-0039	XRS-0075	1134.5	646.0	1527.5	105	-39.0	64.1	170.1	170	30	281	80	225	1000	600	150
XRS-0040*	XRS-0076*	1134.5	646.0	1527.5	105	-39.0	64.6*	170.1	170	30	281	80	225	1000	600	150
XRS-0041	XRS-0077	934.5	-	1117.6	105	-158.3	-	170.1	-	30	281	35	225	650	400	-
XRS-0042	XRS-0078	934.5	530.8	1117.6	105	-115.3	82.6	170.1	156	30	281	35	225	650	400	100
XRS-0043	XRS-0079	934.5	646.0	1117.6	105	-111.0	64.1	170.1	170	30	281	35	225	650	400	150
XRS-0044*	XRS-0080*	934.5	646.0	1117.6	105	-111.0	64.6*	170.1	170	30	281	35	225	650	400	150
XRS-0045	XRS-0081	1134.5	-	1117.6	105	-158.3	-	170.1	-	30	281	35	225	650	600	-
XRS-0046	XRS-0082	1134.5	530.8	1117.6	105	-115.3	82.6	170.1	156	30	281	35	225	650	600	100
XRS-0047	XRS-0083	1134.5	646.0	1117.6	105	-111.0	64.1	170.1	170	30	281	35	225	650	600	150
XRS-0048*	XRS-0084*	1134.5	646.0	1117.6	105	-111.0	64.6*	170.1	170	30	281	35	225	650	600	150
XRS-0049	XRS-0085	1134.5	-	1317.6	105	-158.3	-	170.1	-	30	281	35	225	850	600	-
XRS-0050	XRS-0086	1134.5	530.8	1317.6	105	-115.3	82.6	170.1	156	30	281	35	225	850	600	100
XRS-0051	XRS-0087	1134.5	646.0	1317.6	105	-111.0	64.1	170.1	170	30	281	35	225	850	600	150
XRS-0052*	XRS-0088*	1134.5	646.0	1317.6	105	-111.0	64.6*	170.1	170	30	281	35	225	850	600	150

* Models indicated have the Z-axis mounted to the Y-axis "carriage to carriage", hence the Z-axis will extend & retract vertically. Note that the F dimension is established when the Z-axis is at the top of the stroke.



Large Platform Dimensions

Dimensions (mm)

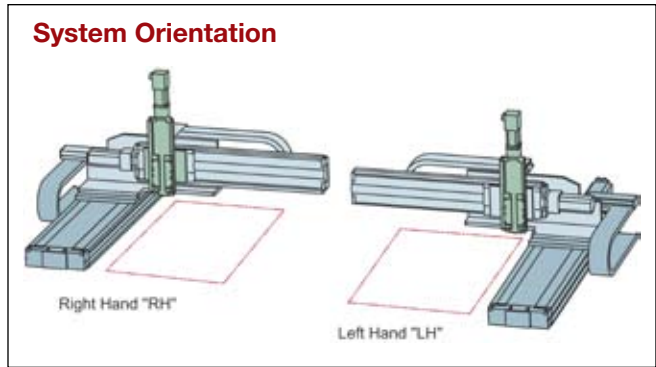
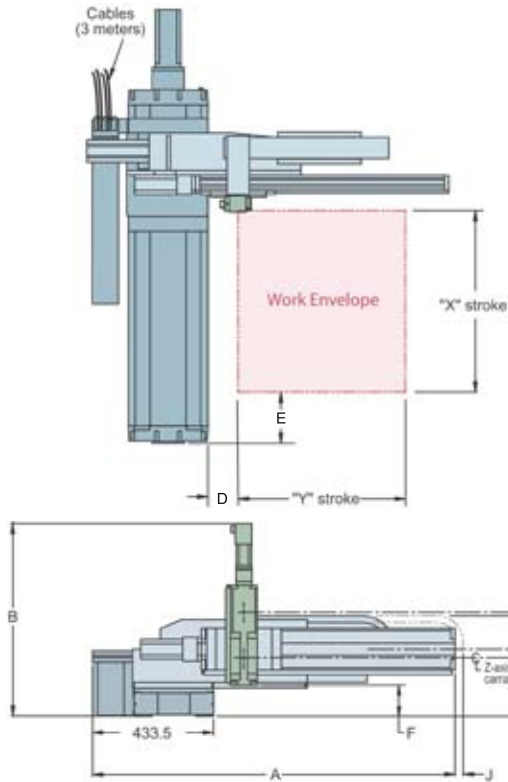

Screw Driven Tables

Right Hand System Number	Left Hand System Number	Dimensions (mm)													
		A	B	C	D	E	F	G	H	J	K	L	X	Y	Z
XRS-0089	XRS-0107	1299.0	-	1553.5	108.5	-222.3	-	239.9	-	80	389.9	0	650	600	-
XRS-0090	XRS-0108	1299.0	690.3	1553.5	108.5	-175.0	108.9	239.9	214.9	80	389.9	0	650	600	150
XRS-0091*	XRS-0109*	1299.0	715.3	1553.5	108.5	-175.0	133.9*	239.9	239.9	80	389.9	0	650	600	150
XRS-0092	XRS-0110	1299.0	-	1553.5	108.5	-222.3	-	239.9	-	80	389.9	0	1000	600	-
XRS-0093	XRS-0111	1299.0	690.3	1553.5	108.5	-175.0	108.9	239.9	214.9	80	389.9	0	1000	600	150
XRS-0094*	XRS-0112*	1299.0	715.3	1553.5	108.5	-175.0	133.9*	239.9	239.9	80	389.9	0	1000	600	150
XRS-0095	XRS-0113	1699.0	-	1903.5	108.5	-222.3	-	239.9	-	80	389.9	0	1000	1000	-
XRS-0096	XRS-0114	1699.0	690.3	1903.5	108.5	-175.0	108.9	239.9	214.9	80	389.9	0	1000	1000	150
XRS-0097*	XRS-0115*	1699.0	715.3	1903.5	108.5	-175.0	133.9*	239.9	239.9	80	389.9	0	1000	1000	150
XRS-0098	XRS-0116	1392.5	-	1264.0	100.0	-222.3	-	239.9	-	80	389.9	0	650	650	-
XRS-0099	XRS-0117	1392.5	690.3	1264.0	100.0	-175.0	108.9	239.9	214.9	80	389.9	0	650	650	150
XRS-0100*	XRS-0118*	1392.5	715.3	1264.0	100.0	-175.0	133.9*	239.9	239.9	80	389.9	0	650	650	150
XRS-0101	XRS-0119	1392.5	-	1614.0	100.0	-222.3	-	239.9	-	80	389.9	0	1000	650	-
XRS-0102	XRS-0120	1392.5	690.3	1614.0	100.0	-175.0	108.9	239.9	214.9	80	389.9	0	1000	650	150
XRS-0103*	XRS-0121*	1392.5	715.3	1614.0	100.0	-175.0	133.9*	239.9	239.9	80	389.9	0	1000	650	150
XRS-0104	XRS-0122	1592.5	-	1614.0	100.0	-222.3	-	239.9	-	80	389.9	0	1000	850	-
XRS-0105	XRS-0123	1592.5	690.3	1614.0	100.0	-175.0	108.9	239.9	214.9	80	389.9	0	1000	850	150
XRS-0106*	XRS-0124*	1592.5	715.3	1614.0	100.0	-175.0	133.9*	239.9	239.9	80	389.9	0	1000	850	150

* Models indicated have the Z-axis mounted to the Y-axis "carriage to carriage", hence the Z-axis will extend & retract vertically. Note that the F dimension is established when the Z-axis is at the top of the stroke.

402/403XE Series Positioners

Features

- Integrated bearing
- Rigid steel body
- Significant force per dollar value
- Easily integrated into multi-axis designs
- Adjustment free
- Small package size

Reliable, Cost-Effective Positioning

The 402/403XE series of positioners combines a rugged steel body construction with an integrated precision ballscrew and bearing guide to produce a highly accurate, cost-effective line of positioners ideal for applications in the hard disk, semiconductor, medical, machine building and many other industries.

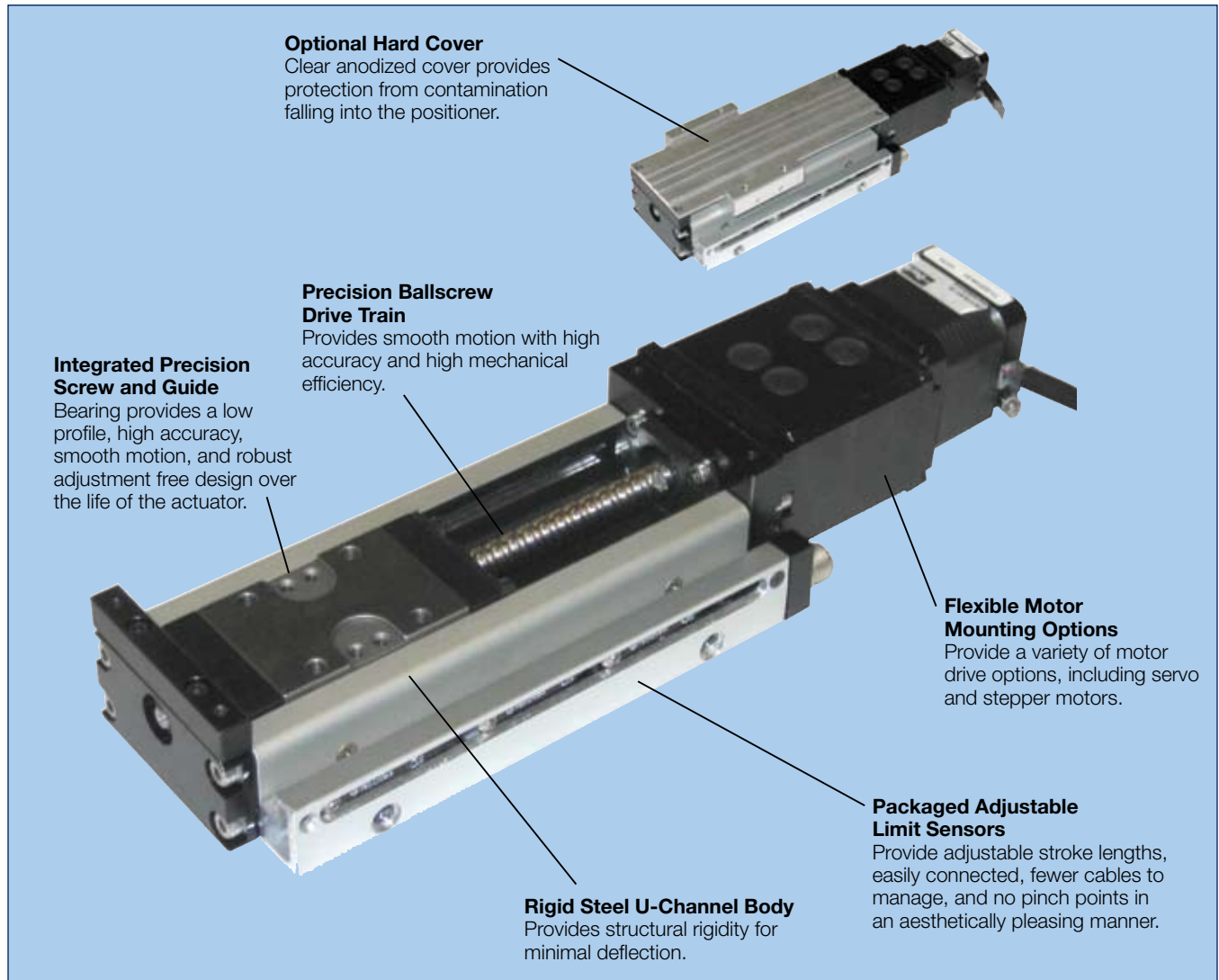
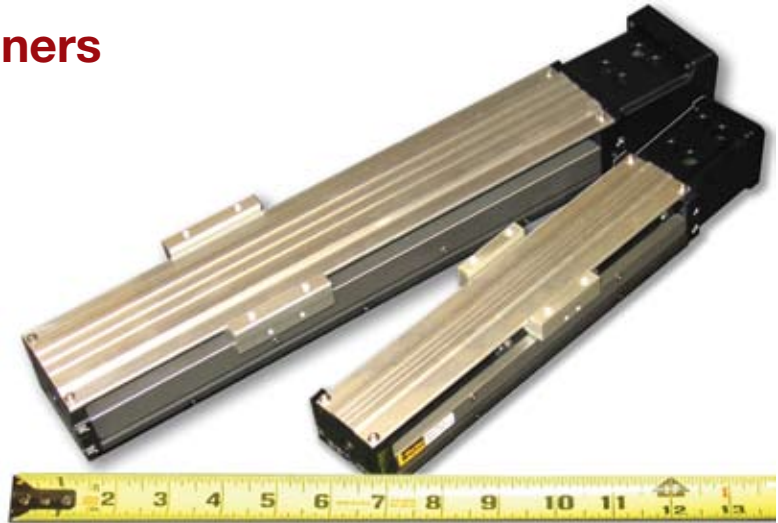



Common Performance Specifications

Specifications	Units	402XE		403XE	
		2 mm Lead	5 mm Lead	5 mm Lead	10 mm Lead
Repeatability	µm	± 5		± 5	
Flatness	µm	15		see below	
Straightness	µm	15		see below	
Breakaway Torque	Nm	0.06		0.15	
Maximum Input Speed	RPS	90		see below	
Maximum Normal Load	kg	90		160	
Maximum Inverted Load	kg	90		160	
Static Permissible Pitch Moment	Nm	46		101	
Static Permissible Roll Moment	Nm	134		260	
Static Permissible Yaw Moment	Nm	51		120	
Torsional Pitch Stiffness	Arc-second/Nm	17.7		9.2	
Torsional Yaw Stiffness	Arc-second/Nm	11.8		6.1	
Torsional Roll Stiffness	Arc-second/Nm	5.9		5.9	
Drive Screw Diameter	mm	8		10	
Drive Screw Efficiency	%	90		90	
Linear Bearing Coefficient of Friction		0.01		0.01	
Running Torque	Nm	0.05		0.10	
Maximum Axial Load	Kg	13	17	31	27
Moment of Inertia X of Guide Rail	mm ⁴	1.44 E+04		3.88 E+04	
Moment of Inertia Y of Guide Rail	mm ⁴	1.37 E+05		3.14 E+05	
Weight of Carriage	kg	0.26		0.3	
Maximum Acceleration	g's	2		2	
Allowable Duty Cycle	%	100		100	

Screw Driven
Tables

402XE Specifications

Specifications	Units	T01 (70 mm)	T02 (120 mm)	T03 (170 mm)	T04 (220 mm)
402XE with 2 mm Lead					
Accuracy over travel	µm	70	75	85	90
Input Inertia	x10 ⁻⁶ (Kg-m ²)	0.615	0.772	0.929	1.09
Weight of Total Table	Kg	1.19	1.40	1.60	1.81
402XE with 5 mm Lead					
Accuracy over travel	µm	70	75	85	90
Input Inertia	x10 ⁻⁶ (Kg-m ²)	0.741	0.898	1.06	1.21
Weight of Total Table	Kg	1.19	1.40	1.60	1.81

403XE Specifications

Specifications	Units	T01 (55 mm)	T02 (105 mm)	T03 (205 mm)	T04 (305 mm)	T05 (305 mm)	T06 (505 mm)	T07 (605 mm)	T08 (655 mm)
403XE with 5 mm Lead									
Travel Accuracy	µm	70	80	90	95	100	110	120	n/a
Flatness	µm	15	15	15	15	25	25	25	n/a
Straightness	µm	15	15	15	15	25	25	25	n/a
Maximum Input Speed	RPS	80	80	80	80	80	80	60	n/a
Input Inertia	x10 ⁻⁶ (Kg-m ²)	1.72	2.10	2.87	3.63	4.40	5.17	5.93	n/a
Weight of Total Table	Kg	1.85	2.25	2.85	3.55	4.25	4.85	5.55	n/a
403XE with 10 mm Lead									
Accuracy over travel	µm	70	80	90	95	100	110	120	130
Maximum Input Speed	RPS	80	80	80	80	80	80	60	42
Input Inertia	x10 ⁻⁶ (Kg-m ²)	2.50	2.88	3.65	4.42	5.18	5.95	6.7	7.10
Weight of Total Table	Kg	1.85	2.25	2.85	3.55	4.25	4.85	5.55	5.85

402/403XE Load-Life Performance

The following performance information is provided as a supplement to the product specification pages. The useful life of a linear table at full catalog specifications is dependent on the forces acting upon it. These forces include both static components resulting from payload weight, and dynamic components due to acceleration/deceleration of the load. In multi-axis applications, the primary positioner at the bottom of the stack usually

establishes the load limits for the combined axes. When evaluating life versus load, it is critical to include the weight of all positioning elements that contribute to the load supported by the primary axis. The following graphs are used to establish the table life relative to the applied loads. For more information, download the product manual at www.parkermotion.com or contact our applications department at (800) 245-6903.

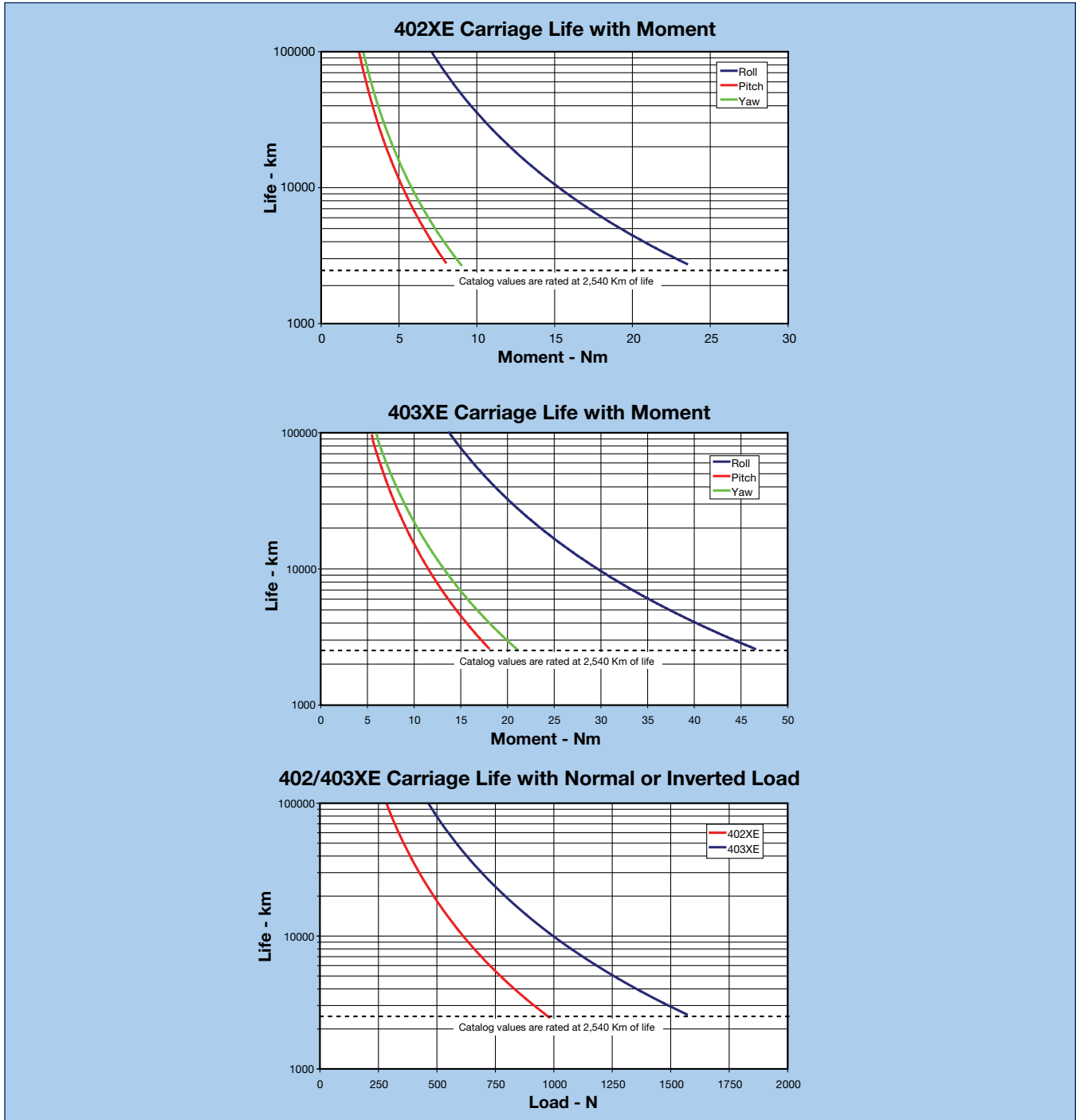

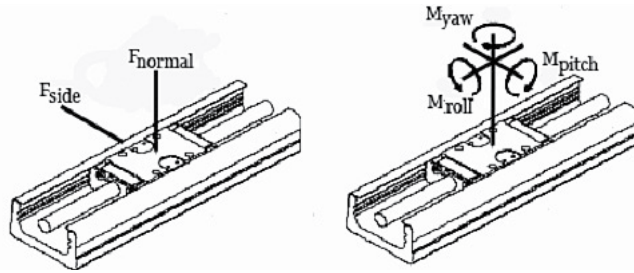

Screw Driven Tables

402/403XE Carriage Life with Side Load

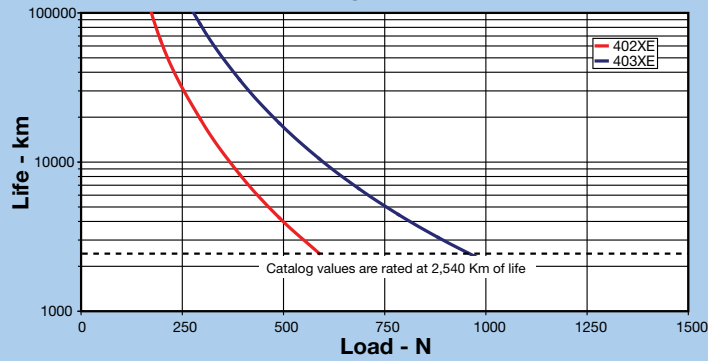

402XE Ballscrew Life with Axial Load

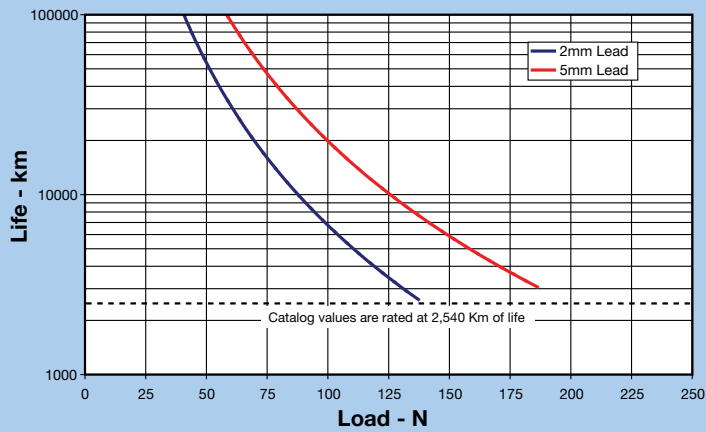

403XE Ballscrew Life with Axial Load

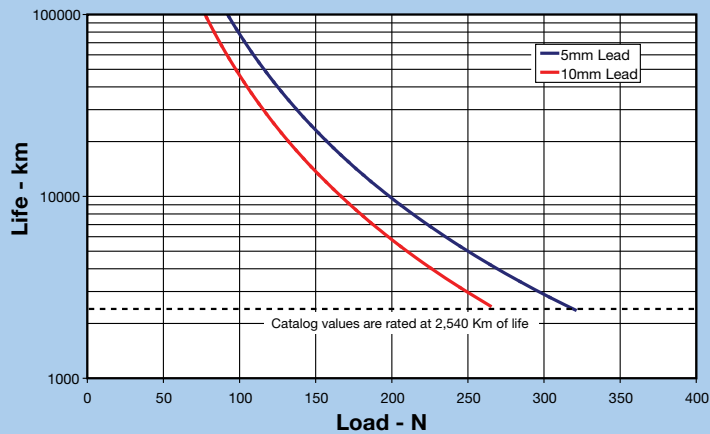

The 402/403XE Series offers complete flexibility, from motor-mounting options to cleanroom compatibility and a variety of offerings in between. Whether the application calls for a hardcover protection for the linear guide, cleanroom-compatible solutions, custom motors mounted at the factory, or an aesthetically appealing engineered limit sensor package, the 402/403XE can be customized to fit the task at hand.

Motor Mounting Flexibility



With standard options for the NEMA 17, NEMA 16, NEMA 23, and other Parker Automation motors, the 402/403XE allows the user to select the motor of their choice without being restricted to one model. To further customize the application solution, the 402/403XE can be ordered ready to mount onto most other manufacturers' motors as well.

Low-Profile Design



The highly integrated ballscrew and guide bearing design allows for a greatly reduced overall height when compared to traditional stacking of a bearing and screw assembly. This results in a more compact footprint.

Rigidity



With the steel U channel body and integrated bearing design, the structural rigidity of the 402/403XE is significantly stiffer than most aluminum body positioners. The increased stiffness results in reduced overall cost due to the elimination of support structures.

Hardcover Protection



For added protection to the bearing system and drive train, an optional hardcover is available. This will bring the positioner to an IP20 rating and prevent large particles from entering and damaging the screw or bearings.

Cleanroom & Raydent Coatings

Cleanroom ratings are possible with the XE product. The actual cleanroom rating will be dependent upon such variables as the location of the sniffer device, the velocity of the table, etc. Consult the factory for specific cleanroom-capability details or test results.



Riser Plates

Most of the motors used with the 402/403XE and some of the 404XE motors have a taller profile than the positioner. Thus the motor can interfere with the positioner mounting surface. To accommodate riser plates can be provided to space the unit above the mounting surface. See XE product Manual for dimensional details and part numbers. Also available are X-Y transition plates for XE to XE and LP mounting.

402/403XE Demo Units

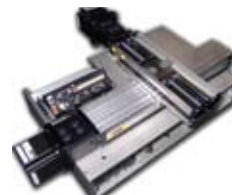

Order 803-0346 for a multi-axis demo unit to learn the product and display for shows and presentations. The demo will come in a watertight pelican carrying case and will be ready for demonstration programmed from the factory.



Packaged Limit Sensors

Limit sensor flexibility allows for a completely packaged sensor kit with a connectorized cable and a single cable to manage multi-axis solutions. It also allows for a simpler sensor pack out of which the sensor wires exit in a flying-leads style with 3 meters of cable from the point of the sensor. To further accommodate each application's unique needs, the sensors can be specified as NPN, PNP, normally open, or normally closed varieties. With the unmatched design, the sensor pack on the 402/403XE allows for fully adjustable sensors along the travel length of the positioner, which creates no pinch points for other cables or hoses to be sliced.

The limit/home switch installed on the 402XE and 403XE is a Hall effect sensor tripped by a magnet located in a housing attached to the carriage. On the switch body is an LED to indicate activation. Normally open sensors are typically used for home and normally closed are typically used for limits. With a current sinking sensor, the output lead provides a path to ground when activated, and with a current sourcing sensor, the output lead provides a positive (+) voltage potential relative to ground. Refer to your controller's manual for compatibility. Limit/home switch information is below.

Limit sensor mounting screws are reverse-thread style so tightening the screw loosens the limit sensor in the track and vice versa.



Screw Driven Tables

402/403XE Wiring Code

Power (+)	Brown
Output Signal	Black
Ground (-)	Blue

402/403XE Sensor Pack Wiring Code

Power (+)	Red
Limit 1 ⁽¹⁾ Output Signal	Blue
Limit 1 ⁽¹⁾ Output Signal	Orange
Home Output Signal	Green
Ground (-)	Blue
Shield (Connect to Earth Ground)	Green w/ Yellow Stripe

(1) Limit 1 is the switch farthest from the connector on the sensor pack housing; Limit 2 is the switch closest to the connector.

402/403XE Home/Limit Switch Specifications

	Units	H2 or L2 Option	H3 or L3 Option	H4 or L4 Option	H5 or L5 Option	H11 or L11 Option	H12 or L12 Option	H13 or L13 Option	H14 or L14 Option
Switch Type		N.C.	N.O.	N.C.	N.O.	N.C.	N.O.	N.C.	N.O.
Logic		NPN	NPN	PNP	PNP	NPN	NPN	PNP	PNP
Operating Voltage	VDC					10-30			
Voltage Drop	VDC (Max)					2.5			
Continuous Current	mA					100			
Repeatability	μ (Max)					100			
Reverse Polarity Protection						Yes			
Short-Circuit Protection						Yes			
Power-Up Pulse Suppression						Yes			
Enclosure Rating						IP67			
Operating Temperature	°C					-25 to +75			
Cable Length	m		3.0 m from Switch				3.0 m from end of Sensor Pack		



402XE with Hardcover

Dimensions (mm)

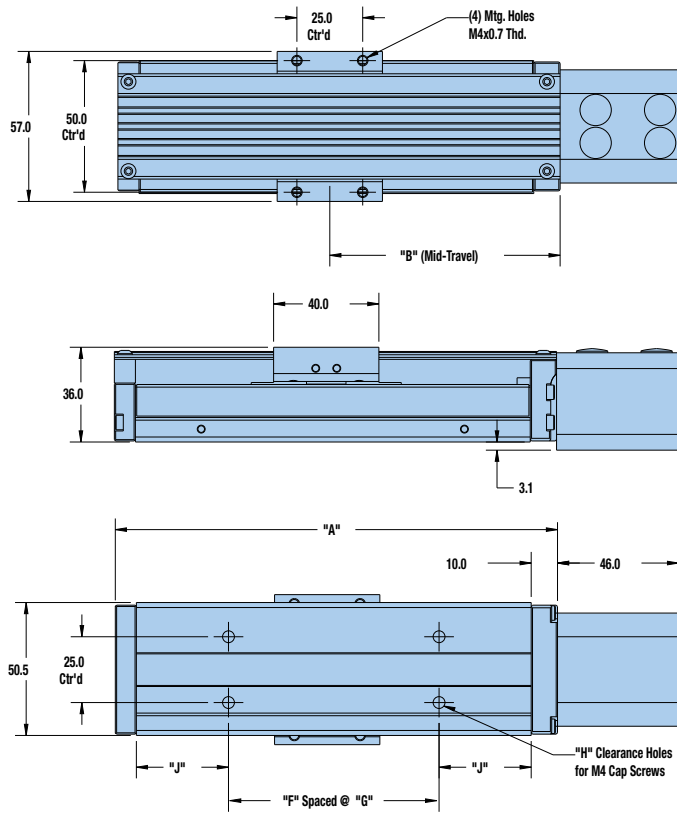

Order Code	Travel	"A"	"B"	"F"	"G"	"H"	"J"
T01	70 mm	168.0	87.5	1	80.0	4	35.0
T02	120 mm	218.0	112.5	2	160.0	6	20.0
T03	170 mm	268.0	137.5	2	160.0	6	45.0
T04	220 mm	318.0	162.5	3	240.0	8	30.0

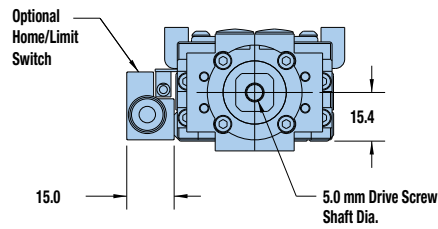

402XE without Hardcover

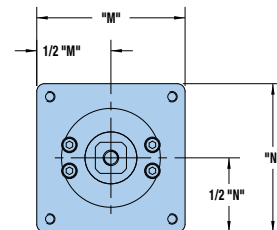
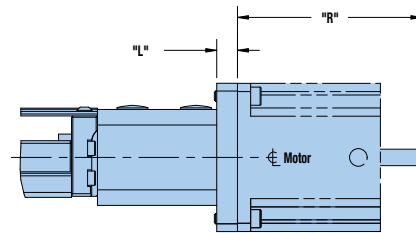
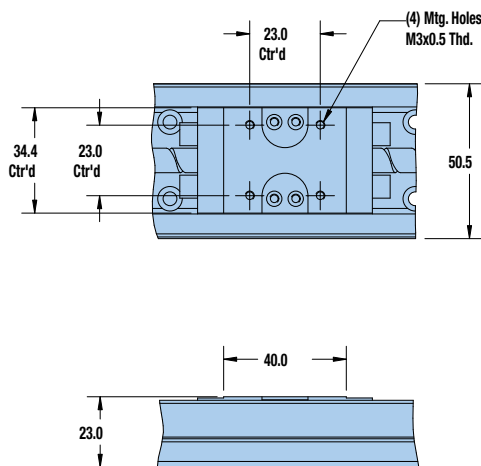

Motor Option	Motor or Motor Size	L	M	N	R
M2	SM16/BE16	8.0	40.6	40.6	-
M3	NEMA23/SM23	8.0	57.2	57.2	-
M37	NEMA17	8.0	43.0	37.0	-
M41	SM162AQ-NPSN	8.0	37.0	40.6	136.7
M46	HV232-02-10	8.0	57.2	57.2	71.1
M61	BE23	15.0	57.2	57.2	-



403XE with Hardcover

Dimensions (mm)

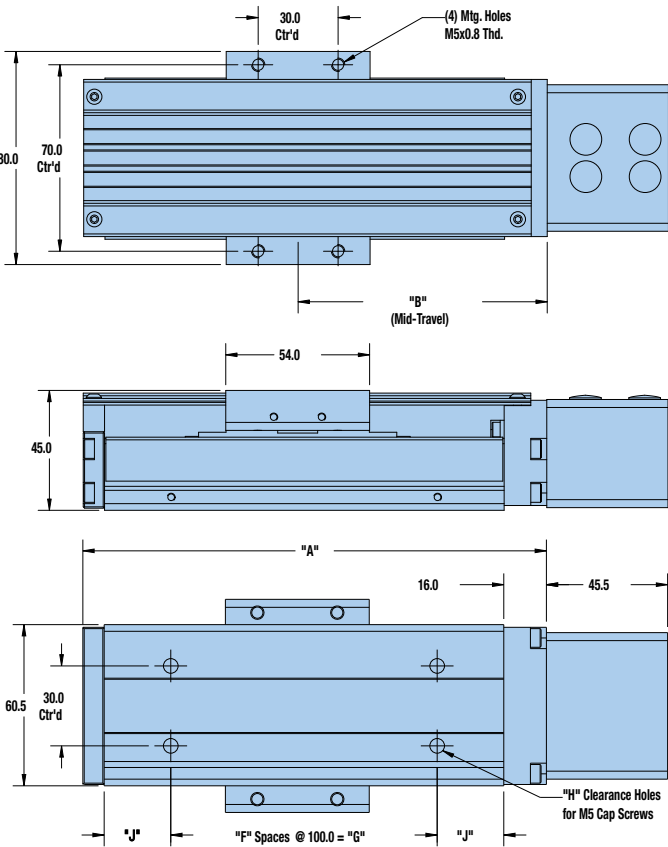

Order Code	Travel	"A"	"B"	"F"	"G"	"H"	"J"
T01	55 mm	174.0	93.5	1	100.0	4	25.0
T02	105 mm	224.0	118.5	1	100.0	4	50.0
T03	205 mm	324.0	168.5	2	200.0	6	50.0
T04	305 mm	424.0	218.5	3	300.0	8	50.0
T05	405 mm	524.0	268.5	4	400.0	10	50.0
T06	505 mm	624.0	318.5	5	500.0	12	50.0
T07	605 mm	724.0	368.5	6	600.0	14	50.0
T08	655 mm	774.0	383.5	7	700.0	16	25.0

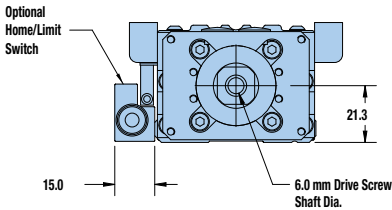

Screw Driven Tables

403XE without Hardcover

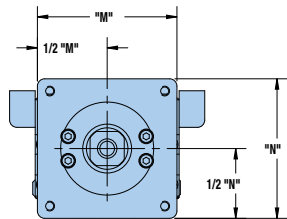
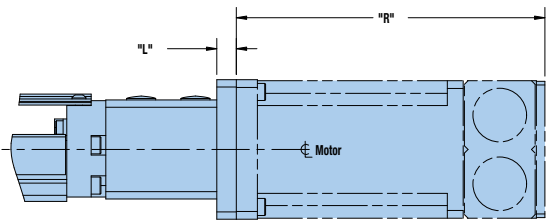
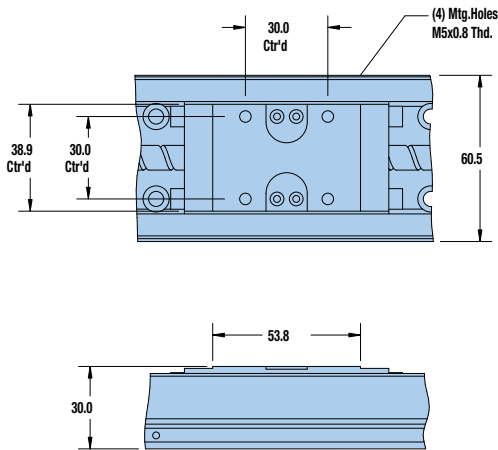

Motor Option	Motor or Motor Size	L	M	N	R
M2	SM16/BE16	8.0	40.6	40.6	-
M3	NEMA23/SM23	8.0	57.2	57.2	-
M37	NEMA17	8.0	55.0	37.0	-
M41	SM162AQ-NPSN	8.0	40.6	40.6	136.7
M42	SM232AQ-NPSN	8.0	57.2	57.2	126.5
M46	HV232-02-10	8.0	57.2	57.2	71.1
M61	BE23	15.0	57.2	57.2	-



Fill in an order code from each of the numbered fields to create a complete model order code.

① ② ③ ④ ⑤ ⑥ ⑦ ⑧ ⑨ ⑩ ⑪

Order Example: 402 T03 XE S D9 H4 L5 M2 C3 R11 P1

① **Series**

402 50 mm

② **Travel**

T01* 70 mm
T02 120 mm
T03 170 mm
T04 220 mm

* Limited to H1L2, H1L3, H1L4, H1L5, H1L1, or H2L1, H3L1, H4L1, or H5L1 home and limit options

③ **Family**

XE XE Series

④ **Grade**

S Standard Grade

⑤ **Drive Screw**

D2 5 mm
D9 2 mm

⑥ **Home Sensor**

H1 No home sensor
H2 N.C. sinking, flying leads
H3 N.O. sinking flying leads
H4 N.C. sourcing, flying leads
H5 N.O. sourcing, flying leads
H11* N.C. sinking, sensor pack
H12* N.O. sinking, sensor pack
H13* N.C. sourcing, sensor pack
H14* N.O. sourcing, sensor pack

* Must be ordered with L11, L12, L13, or L14 limit option

⑦ **Limit Sensor**

L1 None
L2 N.C. sinking, flying leads
L3 N.O. sinking, flying leads
L4 N.C. sourcing, flying leads
L5 N.O. sourcing, flying leads
L11 N.C. sinking, sensor pack
L12 N.O. sinking, sensor pack
L13 N.C. sourcing, sensor pack
L14 N.O. sourcing, sensor pack

⑧ **Motor Mount**

M1 MTR block coupling housing only
M2 MTR block with flange kit for SM16
M3 MTR block with flange kit for NEMA 23
M37 MTR block with flange kit for NEMA 17
M41* SM162AQ-NPSN motor mounted
M46** HV232-02-10 stepper motor mounted
M61 MTR block with flange kit for BE23

* Order with C2 or C3 coupling option

** Order with C4 or C5 coupling option

⑨ **Motor Coupling**

C1 Not required
C2 0.25" Oldham
C3 0.25" Bellows
C4 0.375" Oldham
C5 0.375" Bellows
C24 5 mm Oldham
C25 5 mm Bellows

⑩ **Environmental Options**

R11 Hard cover
R12* Hard cover, cleanroom prep
R13 No cover
R14* No cover, cleanroom prep

* Cleanroom class rating should be checked for each application due to variation of compatibility at different speeds

⑪ **Orthogonality Options**

P1 X axis for single axis
P20* X axis for X-Y assembly motor @ 12:00
P43* Y axis for X-Y assembly motor @ 3:00
P49* Y axis for X-Y assembly motor @ 9:00

* Pinning to 130 arc-sec orthogonality. Additional bracketing required. Contact factory for details.



Fill in an order code from each of the numbered fields to create a complete model order code.

- ① ② ③ ④ ⑤ ⑥ ⑦ ⑧ ⑨ ⑩ ⑪

Order Example: 403 T04 XE S D2 H3 L2 M4 C3 R13 P1

① Series

403 60 mm

② Travel

- T01* 55 mm
- T02* 105 mm
- T03 205 mm
- T04 305 mm
- T05 405 mm
- T06 505 mm
- T07 605 mm
- T08** 655 mm

* Limited to H1L2, H1L3, H1L4, H1L5, H1L1, or H2L1, H3L1, H4L1, or H5L1 home and limit options
 ** Only available with D3 drive option

③ Family

XE XE Series

④ Grade

S Standard Grade

⑤ Drive Screw

- D2 5 mm
- D3 10 mm

⑥ Home Sensor

- H1 No home sensor
- H2 N.C. sinking, flying leads
- H3 N.O. sinking flying leads
- H4 N.C. sourcing, flying leads
- H5 N.O. sourcing, flying leads
- H11* N.C. sinking, sensor pack
- H12* N.O. sinking, sensor pack
- H13* N.C. sourcing, sensor pack
- H14* N.O. sourcing, sensor pack

* Must be ordered with L11, L12, L13, or L14 limit option

⑦ Limit Sensor

- L1 None
- L2 N.C. sinking, flying leads
- L3 N.O. sinking, flying leads
- L4 N.C. sourcing, flying leads
- L5 N.O. sourcing, flying leads
- L11 N.C. sinking, sensor pack
- L12 N.O. sinking, sensor pack
- L13 N.C. sourcing, sensor pack
- L14 N.O. sourcing, sensor pack

⑧ Motor Mount

- M1 MTR block coupling housing only
- M2 MTR block with flange kit for SM16
- M3 MTR block with flange kit for NEMA 23
- M37 MTR block with flange kit for NEMA 17
- M41* SM162AQ-NPSN motor mounted
- M46** HV232-02-10 stepper motor mounted
- M61 MTR block with flange kit for BE23

* Order with C2 or C3 coupling option

** Order with C4 or C5 coupling option

⑨ Motor Coupling

- C1 Not required
- C2 0.25" Oldham
- C3 0.25" Bellows
- C4 0.375" Oldham
- C5 0.375" Bellows
- C24 5 mm Oldham
- C25 5 mm Bellows

⑩ Environmental Options

- R11 Hard cover
- R12* Hard cover, cleanroom prep
- R13 No cover
- R14* No cover, cleanroom prep

* Cleanroom class rating should be checked for each application due to variation of compatibility at different speeds

⑪ Orthogonality Options

- P1 X axis for single axis
- P20* X axis for X-Y assembly motor @ 12:00
- P43* Y axis for X-Y assembly motor @ 3:00
- P49* Y axis for X-Y assembly motor @ 9:00

* Pinning to 130 arc-sec orthogonality. Additional bracketing required. Contact factory for details.

Screw Driven Tables



404XE Series Positioners (95 mm wide profile)

Features

- Economy Grade Positioning
- 100% Duty Cycle
- High Strength Design
- Easy Multi-Axis Mounting
- Locating Dowel Holes



Reliable and Cost Effective Positioning

The 404XE positioners combine versatility with rugged construction in a compact motion platform that is ideal for 24/7 process automation. A high efficiency ballscrew drive, recirculating square rail bearings and high strength aluminum body are the result of innovative engineering that has reduced costs while improving performance.

Unmatched Options and Features

A vast assortment of “designer friendly” options and features simplify the engineering challenges often confronted with “base model” positioning devices. Features like precision dowel holes, linear feedback, sensor packs, parallel motor mounting, brakes, and cleanroom preparation simplify and speed your machine design process.



Multi-Axis Systems

XY and XYZ systems are easily configured and pinned so that factory orthogonality can be reproduced in the field. Motors and cable management systems connect to the XE tables in a straightforward and simple manner.



Technology Evolution

The XE is direct mounting compatible with our precision series XR ballscrew tables and our LXR linear motor tables. It is possible to mix-and-match various levels of technology on a per axis basis allowing the most cost effective optimized application solutions.





Common Specifications

Bidirectional Repeatability	
T01 to T11 models	±20 micron
T12 to T15 models	±30 micron
Duty Cycle	100%
Max Acceleration⁽¹⁾	20 m/sec ² (773 in/sec ²)
Normal Load Capacity⁽²⁾	
NL (short carriage)	61.3 kgf (135 lbs)
VL (long carriage)	122.6 kgf (270 lbs)
Axial load capacity⁽²⁾	
5 mm lead ballscrew	60 kgf (132 lbs)
10 mm lead ballscrew	70 kgf (154 lbs)
20 mm lead ballscrew	70 kgf (154 lbs)
Drive Screw Efficiency	90%
Max Break-Away Torque	0.25 Nm (35in-oz)
Max Running Torque (rated @ 2 RPS)	0.21 Nm (30in-oz)
Linear Bearing – Coefficient of Friction	0.01
Ball screw Diameter	
5 & 10 mm lead	16 mm
20 mm lead	15 mm
Carriage Weight	
NL (short carriage)	0.215 kg (0.47 lbs)
VL (long carriage)	0.495 kg (1.09 lbs)

(1) Applies to units with VL carriage
 (2) Refer to life/load charts.

Screw Driven Tables

Travel Dependent Characteristics

Code	Travel (mm)		Positional Accuracy ^{(3) (4)} (µm)	Input Inertia NL Carriage Units (10 ⁻⁵ kg-m ²)			Input Inertia VL Carriage Units (10 ⁻⁵ kg-m ²)			Max. Screw Speed (RPS)	Max. Velocity (meters/sec.)			Total Table Weight (kg)	
	NL	VL		5 mm	10 mm	20 mm	5 mm	10 mm	20 mm		5 mm	10 mm	20 mm	NL	VL
T01	25	–	42	.81	–	–	–	–	–	72	0.36	0.73	1.50	1.42	1.70
T02	50	–	50	.94	.98	–	–	–	–	72	0.36	0.73	1.50	1.61	1.89
T03	100	33	58	1.19	1.23	1.12	1.21	1.30	1.4	72	0.36	0.73	1.50	1.95	2.23
T04	150	83	66	1.44	1.48	1.32	1.46	1.55	1.6	72	0.36	0.73	1.50	2.35	2.63
T05	200	133	74	1.69	1.73	1.51	1.71	1.80	1.79	72	0.36	0.73	1.50	2.59	2.87
T06	250	183	82	1.94	1.99	1.70	1.96	2.06	1.99	72	0.36	0.73	1.50	2.97	3.25
T07	300	233	90	2.20	2.24	1.90	2.21	2.31	2.18	72	0.36	0.73	1.50	3.34	3.62
T08	350	283	98	2.45	2.49	2.09	2.47	2.56	2.37	72	0.36	0.73	1.50	3.50	3.78
T09	400	333	106	2.70	2.74	2.29	2.72	2.81	2.57	72	0.36	0.73	1.50	3.83	4.11
T10	450	383	114	2.95	2.99	2.48	2.97	3.07	2.76	72	0.36	0.73	1.50	4.09	4.37
T11	500	433	122	3.21	3.25	2.67	3.22	3.32	2.96	72	0.36	0.73	1.50	4.22	4.50
T12	550	483	130	3.46	3.50	2.87	3.48	3.57	3.15	72	0.36	0.73	1.50	4.55	4.83
T13	600	533	138	3.71	3.75	3.06	3.73	3.82	3.34	69	0.34	0.68	1.32	4.87	5.15
T15	700	633	154	4.21	4.25	3.45	4.23	4.33	3.73	52	0.26	0.52	1.00	5.12	5.40

(3) Positional accuracy applies to in-line motor configurations only. Positional specifications are based on “no-load” conditions and apply to individual axes only.
 (4) Consult factory for specs with linear feedback.



404XE Life-Load Performance

The following performance information is provided as a supplement to the product specifications pages. The useful life of a linear table at full catalog specifications is dependent on the forces acting upon it. These forces include both static components resulting from payload weight and dynamic components due to acceleration/ deceleration of the load. In multi-axes applications, the primary positioner at the bottom of the stack usually

establishes the load limits for the combined axes. When determining life/load, it is critical to include the weight of all positioning elements that contribute to the load supported by the primary axis. The following graphs and formulas are used to establish the table life relative to the applied loads.

Catalog load specifications are rated for 100 million inches of travel or 2.540 km.

Table Life/Thrust (Axial) Load

This graph illustrates table ballscrew life relative to the axial load.

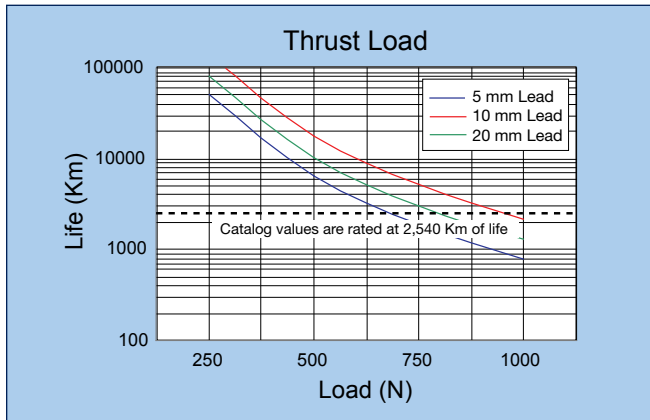

Table Life/Compression (Normal) Load

This graph provides an evaluation of the support bearing life/load characteristics. The curves show the life/load relationship when the applied load is centered on the carriage, normal (perpendicular) to the carriage mounting surface.

For final evaluation of life vs load, including off center, tension, and side loads refer to the pitch/moment chart for the NL carriage units or the bearing load charts (next page) for the VL carriage units.

**Table Life/Load Chart
Pitch Moment - NL (Short Carriage)**

This graph illustrates table linear bearing life as a result of pitch moment.

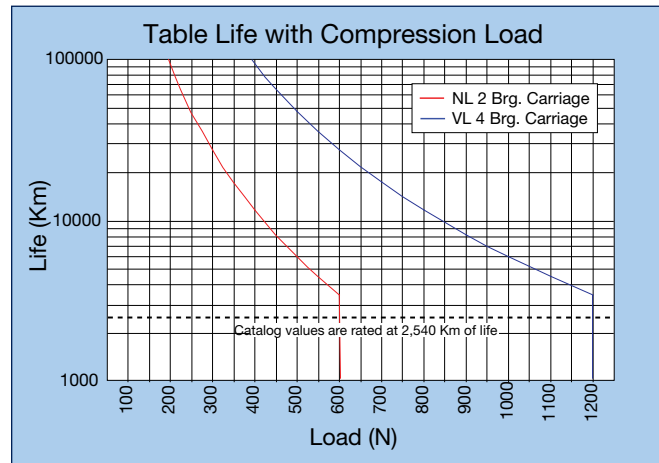
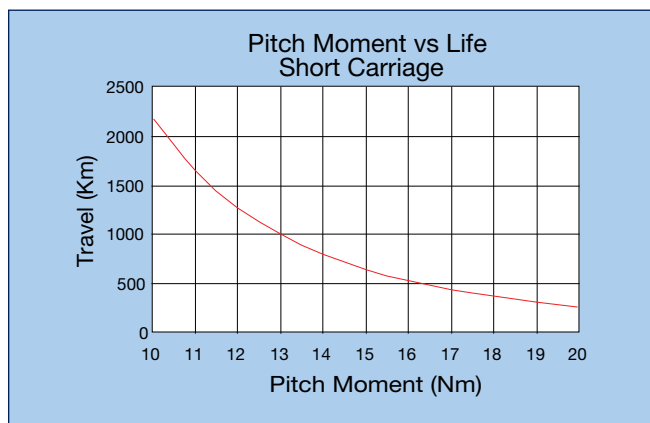



Bearing Life/Load for VL Long Carriage Units

These charts are to be used to evaluate the VL Carriage units. They should be used in conjunction with the corresponding formulas (found under “Product Information” at www.parkermotion.com) to establish the life/load for each bearing (4 per table).

Several dimensions, which are specific to each linear positioning table model, and the load geometry are required for these computations. These dimensions are supplied in the catalog information for each positioner. The dimensions are referenced as follows:

- d1 – bearing block center-to- center longitudinal spacing
- d2 – bearing rail center-to-center lateral spacing
- da – Rail center-to-carriage mounting surface

	d1	d2	da
404XE	80	57	28

Refer to Parker’s website www.parkermotion.com for moment loading and other engineering data.

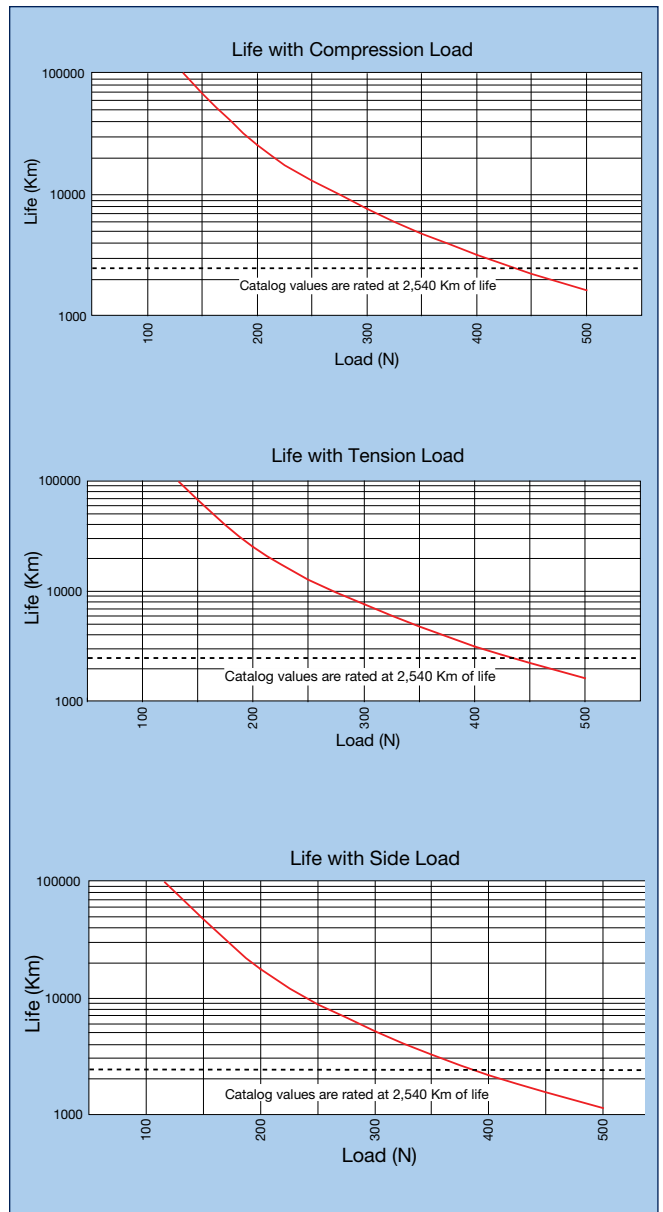

Screw Driven Tables

Home or Limit Sensor

End of Travel and Home Sensors for the 404XE series are available in a variety of styles. The sensors can be ordered as part of the table or as separate components with the associated mounting hardware or in an enclosed sensor pack. A 5 meter high-flex extension cable (Part No. 003-2918-01) is available for use with models having the locking connector option.

- NPN (Sinking) or PNP (Sourcing)
- Normally Closed (N.C.) or Normally Open (N.O.)
- Flying Leads or Locking Connector



With Limits and Home Sensors



With Limits and Home Sensor Pack

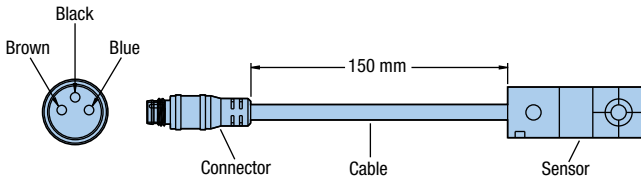

Input Power 5-30 VDC, 20 mA
Output 100 mA max
Wire Color Code (+) Supply: Brown
 (-) Supply: Blue
 NO Output: Black
 NC Output: White

Order Code	Part No.* (Includes Mounting Bracket)	Switch Type	Logic	Cable Length	Connection Option
H2 or L2	006-1639-01	N.C.	Sinking	3.0 m	Flying Leads
H3 or L3	006-1639-02	N.O.	Sinking	3.0 m	Flying Leads
H4 or L4	006-1639-03	N.C.	Sourcing	3.0 m	Flying Leads
H5 or L5	006-1639-04	N.O.	Sourcing	3.0 m	Flying Leads
H6 or L6	006-1639-09	N.C.	Sinking	150 mm	Locking Connector
H7 or L7	006-1639-08	N.O.	Sinking	150 mm	Locking Connector
H8 or L8	006-1639-11	N.C.	Sourcing	150 mm	Locking Connector
H9 or L9	006-1639-10	N.O.	Sourcing	150 mm	Locking Connector

*Sensor triggers (targets) ordered separately.

Brake Assembly

Electromagnetic brake assembly used to prevent “backdriving” in vertical applications. Includes 5 m cable.

Table Series	Part Number	Input Power	Holding Torque
404XE	006-1627-01	24 VDC, 0.46 A	2.0 N-m

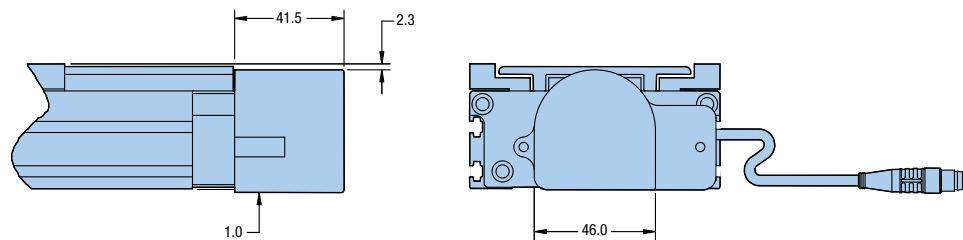



Rotary Encoder

Modular rotary encoder couples directly to the drive screw for position feedback. 150 mm cable included.

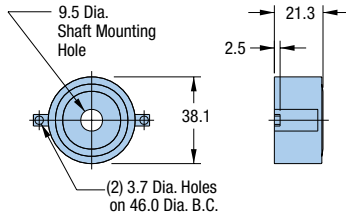

Part Number 06-1629-01

Input Power Output 5 VDC, 135 mA
A/B quadrature and reference mark, differential line drive output

Resolution 1250 lines/rev equals 5000 counts post quadrature (1 µm with 5 mm lead ballscrew)

Riser Plate

Used to raise the table base to provide clearance for motors larger than NEMA 23 frame size.

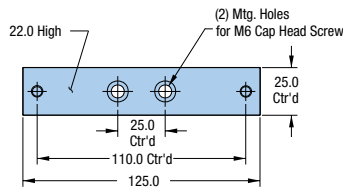

Part Number 002-3619-01
(All hardware included)

Linear Feedback

A magnetic linear position feedback device which mounts directly to the table carriage. (Factory installation required.)



Input Power Output 5 VDC, 240 mA
A/B quadrature and reference marks, differential line drive output

Resolution 5.0 µmm

Dowel Pinning

Standard dowel pin locating holes are offered on all 400XE units to facilitate repeatable mounting of tooling or payload.

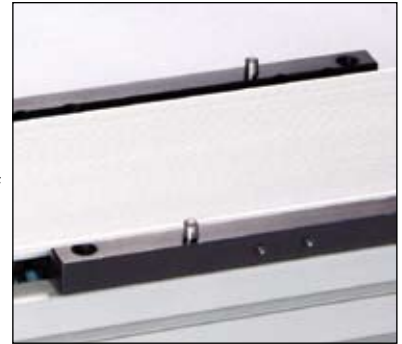

Two locating dowel pins shown in carriage

Multi-axis options are offered with P20 for the base 'X' Axis and P33-59 for the 'Y' orientation and mounting method. "Clock position" call-outs refer to the position of the motor end of the table. The multi-axis option allows the user to choose the motor orientation and mounting style.

P43 & P49 provide toe clamp mounting.

P33 & P39 offers standard pins on the carriage in addition to the toe clamps.

P53 & P59 offers uniquely pinned and toe clamp mounting to ensure the best orthogonality. This is offered for precise orthogonal mounting of the second axis in a multi-axis system. In this case, the bottom side of the table base is match drilled and reamed to the first axis to provide exact orthogonal location. This convenient option eliminates concerns regarding contamination or damage often associated with machining an assembled unit.



X-Y showing 12:00 and 9:00 positions

Toe Clamp

Used for convenient mounting of 404XE to a base plate, or riser plates.

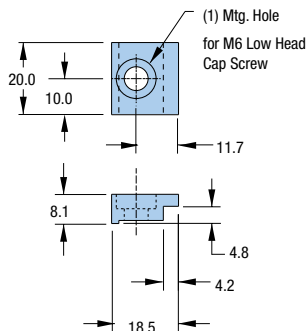

Part Number 002-3618-01

Screw Driven Tables

400XE Series Dimensions

Dimensions (mm)

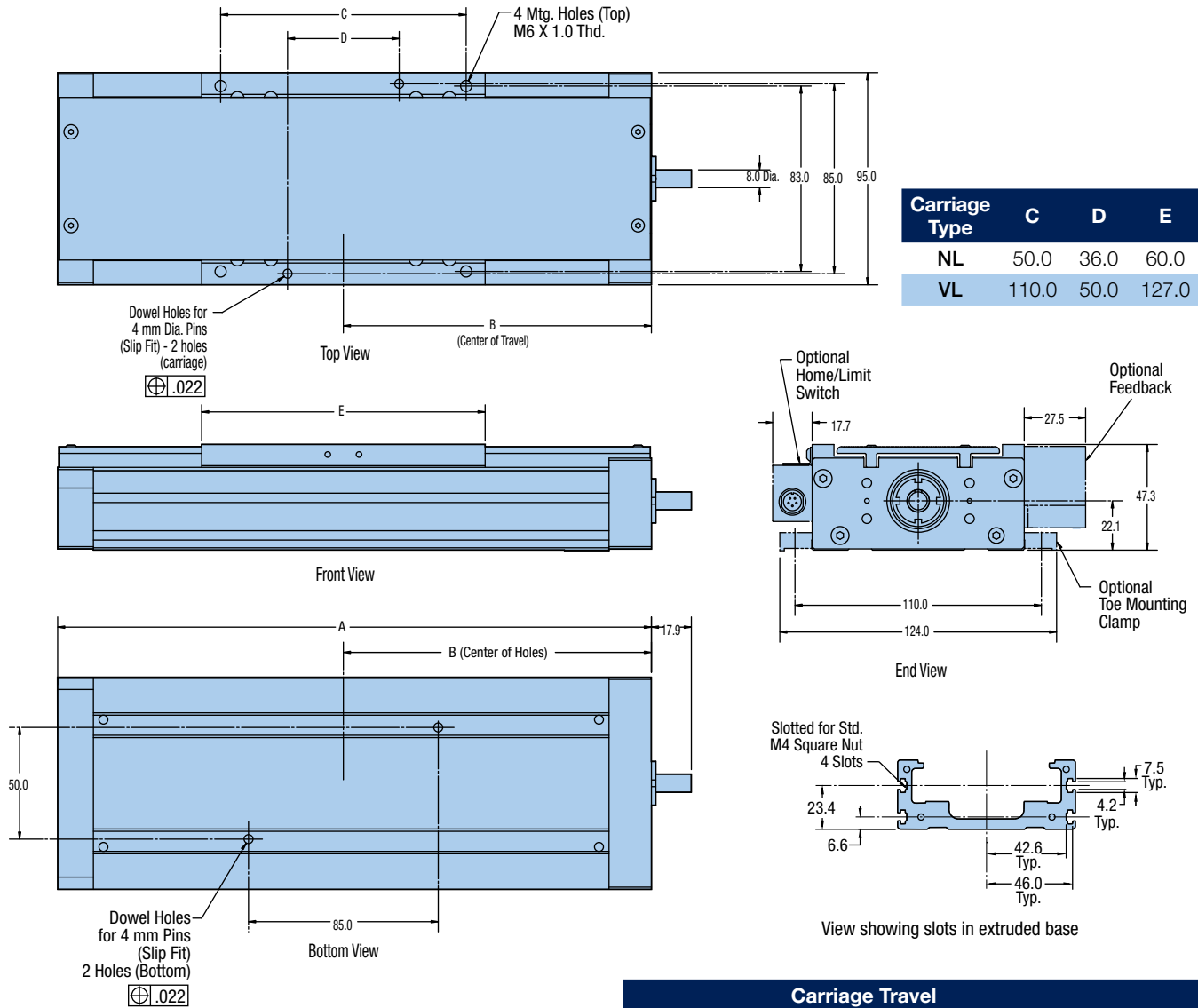

Carriage Type	C	D	E
NL	50.0	36.0	60.0
VL	110.0	50.0	127.0

Designation	Carriage Travel		A	B
	NL (short)	VL (long)		
T01	25	-	141.0	75.5
T02	50	-	166.0	88.0
T03	100	33	216.0	113.0
T04	150	83	266.0	138.0
T05	200	133	316.0	163.0
T06	250	183	366.0	188.0
T07	300	233	416.0	213.0
T08	350	283	466.0	238.0
T09	400	333	516.0	263.0
T10	450	383	566.0	288.0
T11	500	433	616.0	313.0
T12	550	483	666.0	338.0
T13	600	533	716.0	363.0
T15	700	633	816.0	413.0



400XE Series Motor Mount Dimensions

Dimensions (mm)

In-Line Motor Mount

In-line motor mounting allows the motor to be mounted directly to the drive screw via the selected motor coupling.

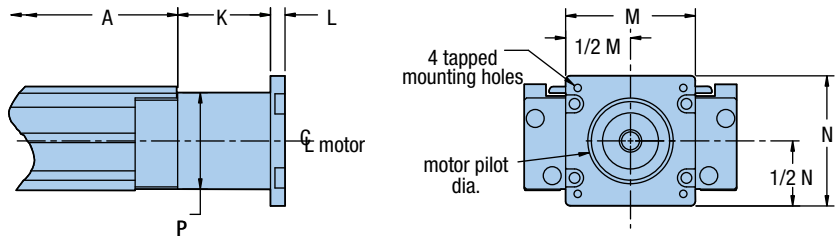

In-Line Adaptor Plates

Used to easily accommodate the mounting of different frame sizes. These adapter plates can be ordered separately by part number below.

Motor Size	Order Code	Max. Motor Shaft Dia.	K	L	M	N	P
SM16	M2	9.5	41.0	4.3	58.0	45.0	45.0
NEMA 23	M3	9.5	41.0	6.5	58.0	58.0	45.0
NEMA 34	M4	9.5	41.0	12.5	83.0	83.0	45.0
Neometric 70	M21	11.0	53.0	0.0	69.9	69.9	69.9

Screw Driven Tables

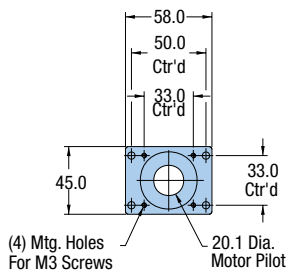

In-line SM 16

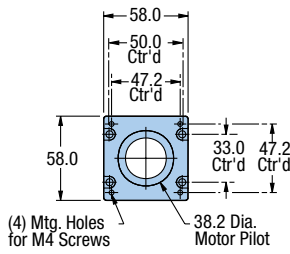

In-line NEMA 23

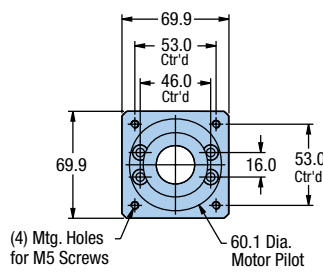

In-line NEOMETRIC 70 /SMN060

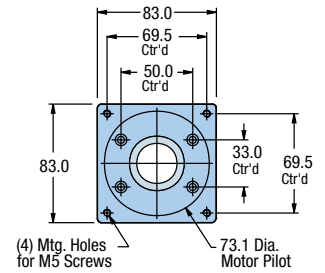

In-line NEMA 34

Parallel Motor Mounting

Parallel motor mounting is employed whenever a shorter overall unit length is needed. The motor is positioned along the sides or bottom of the table as designated by position A, B, or C. (No coupling required)

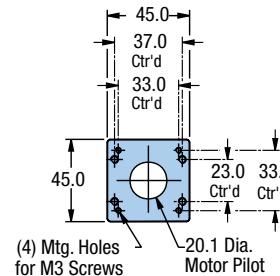
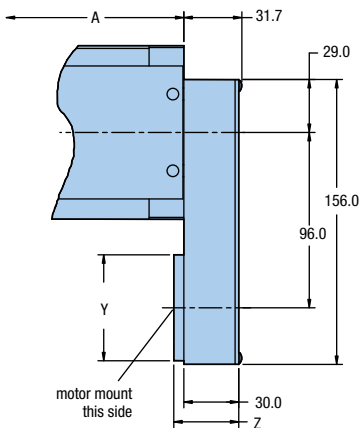

Reverse SM 16

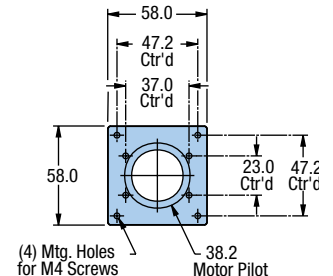

Reverse NEMA 23

Motor Size	Y	Z	Motor Shaft Dia.
SM 16	45.0	34.5	0.250"
SM 23 / BE 23	58.0	35.5	0.375"
NEMA 23	58.0	35.5	0.250"

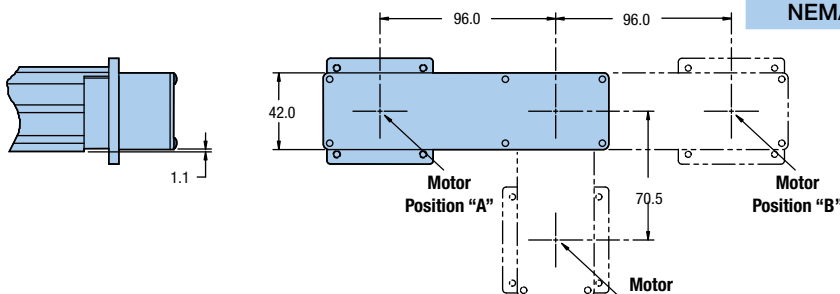

Note: Some sensor pack and encoder restriction apply when mounting motors larger than NEMA 23 in the A or B positions. Please consult factory.



Fill in an order code from each of the numbered fields to create a complete model order code.

① ② ③ ④ ⑤ ⑥ ⑦ ⑧ ⑨ ⑩ ⑪ ⑫ ⑬ ⑭ ⑮

Order Example: 404 T08 XE M S - VL D4 H8 L8 C3 M4 E1 B1 R11 P1

① **Series**
404

② **Table Travel (mm)**

	NL Short Carriage	VL Long Carriage
T01*	25	n/a
T02**	50	n/a
T03	100	33
T04	150	83
T05	200	133
T06	250	183
T07	300	233
T08	350	283
T09	400	333
T10	450	383
T11	500	433
T12	550	483
T13	600	533
T15	700	633

* VL carriage, D3 & D4 drives, and Limit/Home Sensor Pack option are not offered with T01 travel models.

** VL carriage, D4 drive options are not offered with T02 travel models.

③ **Table Style**
XE XE Series

④ **Mounting**
M Metric

⑤ **Grade**
S Standard Grade

⑥ **Carriage Style**
NL Short
VL Long

⑦ **Drive Screw**
D1 Free travel
D2 5 mm ballscrew
D3* 10 mm ballscrew
D4* 20 mm ballscrew

* D3 & D4 drives are not available with T01 travel. D4 drives are not available with T02 travels.

⑧ **Home Sensor (one sensor)**

- H1 No home sensor
- H2 N.C. current sinking, flying leads
- H3 N.O. current sinking flying leads
- H4 N.C. current sourcing, flying leads
- H5 N.O. current sourcing, flying leads
- H6 N.C. current sinking, with locking connector
- H7 N.O. current sinking, with locking connector
- H8 N.C. current sourcing, with locking connector
- H9 N.O. current sourcing, with locking connector
- H11 N.C. current sinking, sensor pack*
- H12 N.O. current sinking, sensor pack*
- H13 N.C. current sourcing, sensor pack*
- H14 N.O. current sourcing, sensor pack*

* Must be ordered with L11-L14 sensor option.

⑨ **Travel Limit Sensor Assembly (two sensors)**

- L1 No limit sensors
- L2 N.C. current sinking, flying leads
- L3 N.O. current sinking, flying leads
- L4 N.C. current sourcing, flying leads
- L5 N.O. current sourcing, flying leads
- L6 N.C. current sinking with locking connector*
- L7 N.O. current sinking with locking connector*
- L8 N.C. current sourcing with locking connector*
- L9 N.O. current sourcing with locking connector*
- L11 N.C. current sinking, sensor pack
- L12 N.O. current sinking, sensor pack
- L13 N.C. current sourcing, sensor pack
- L14 N.O. current sourcing, sensor pack

* Sensors with locking connector include 5 m extension cable.

**10 Motor Coupling**

C1	No coupling (required for parallel mounting)
C2	0.25" Oldham
C3	0.25" Bellows
C4	0.375" Oldham
C5	0.375" Bellows
C6	0.43" Oldham
C7	0.43" Bellows
C10	14 mm Oldham (M75 motor option)
C11	14 mm Bellows (M75 motor option)
C22	9 mm Oldham
C23	9 mm Bellows
C24	5 mm Oldham (M37 NEMA 17)
C25	5 mm Bellows (M37 NEMA 17)
C26	8 mm Oldham (M71 NEMA motor option)
C27	8 mm Bellows (M71 NEMA motor option)
C28	0.19" Oldham (M37 NEMA 17)
C29	0.19" Bellows (M37 NEMA 17)

11 Motor Mount*

M1	No motor mount
M2	SM 16 In-line mounting
M3	NEMA 23 & SM 23 – In-line mounting
M4	NEMA 34 – In-line mounting
M5	SM16 – Parallel mounting, "A" location
M6	SM16 – Parallel mounting, "B" location
M7	SM16 – Parallel mounting, "C" location
M8	NEMA 23 – Parallel mounting, "A" location
M9	NEMA 23 – Parallel mounting, "B" location
M10	NEMA 23 – Parallel mounting, "C" location
M11	SM23 – Parallel mounting, "A" location
M12	SM23 – Parallel mounting, "B" location
M13	SM23 – Parallel mounting, "C" location
M21	Neometric 70 – In-line mounting
M37	NEMA 17 – In-line mounting
M42	SM232AQ-NPSN Servo motor – In-line mounting
M46	HV232-02-10 Stepper motor – In-line mounting
M49	Handcrank/no read out
M51	HDY55 – In-line mounting
M61	BE23 – In-line mounting
M62	BE23 – Parallel mounting, "A" location
M63	BE23 – Parallel mounting, "B" location
M64	BE23 – Parallel mounting, "C" location
M71	SGM01 – In-line mounting
M72	SGM01 – Parallel mounting, "A" location
M73	SGM01 – Parallel mounting, "B" location
M74	SGM01 – Parallel mounting, "C" location
M75	SGM02 – In-line mounting

* Refer to "Motor Mounting Dimensions" for maximum allowable motor shaft diameter.

12 Feedback Option

E1	None
E2	Linear feedback – 5 micron magnetic (not available on T01 units with H2-H9 "home" and L2-L9 "limit" sensors)
E5	Rotary shaft encoder (cannot be used with brake option)

13 Brake Option

B1	No brake
B2	Shaft brake (cannot be used with rotary encoder option)

14 Environmental Protection

R11	Hard cover
R12	Hard cover, cleanroom prep
R13	No cover
R14	No cover, cleanroom prep

15 Multi-Axis Selections

P1	X axis – for single axis use
P20	X axis – for X-Y assembly (VL carriage units only) – motor @ 12:00
P33	Y axis, standard dowel pinned & toe clamped to X axis – motor @ 3:00
P39	Y axis, standard dowel pinned & toe clamped to X axis – motor @ 9:00
P43	Y axis, toe clamped to X axis motor @ 3:00
P49	Y axis, toe clamped to X axis motor @ 9:00
P53	Y axis, precision dowel pinned & toe clamped to X axis motor @ 3:00
P59	Y axis, precision dowel pinned & toe clamped to X axis motor @ 9:00

HD Series Linear Positioners

Features

- Pre-engineered package
- Performance matched components
- Two performance grades available – standard and industrial
- Protection from environment
- Robust design – exceptional beam strength

The HD Series linear table line is a robust, industrial positioner that is easy to apply, easy to install, and easy to maintain. The robust design begins with a deep channel extruded body and carriage that provide exceptional beam strength and carriage stiffness. The linear bearings and ballscrew are precision components selected for their long life at 100% duty operation. The HD Series also includes IP30 rated belt seals that protect the interior components from debris.



The HD Series is very easy to apply. As part of the configurable part number, users can select options such as screw lead, home and limit sensors, a fail safe brake, and motor orientation. With motors as part of the standard table, system-level performance is provided in the form of graphs to enable quick application without the need for a complex motor sizing exercise.

High Efficiency Ballscrew Drive
is precision ground or precision rolled and offered in 5, 10, 20, and 40 mm leads. Like the linear bearings the screw is self lubricating and is maintenance free for the life of the table.

IP30 Rated Belt Seals
protect the table's internal components from falling debris as well as enhance the overall appearance.

High-Performance Brushless Servo Motor
is performance-matched and included with the table in both in-line and parallel configurations. System level performance data is provided to minimize motor sizing requirements.

Dowel Holes
are provided in the base and carriage for repeatable mounting payloads and the table.

Limit/Home Sensors
Hall effect sensors establish "end of travel" and "home" locations and are easily adjustable over the entire travel length. (not shown)

T-Slot Mounting
is available along the entire body length for convenient attachment of accessories and for flexible toe clamp mounting.

Fail-safe Brake
is available to prevent "back driving" and halt carriage motion in vertical applications during power down. (not shown)

Square Rail Linear Bearing
support the carriage and payload to provide high load capacity with smooth, precise, dependable motion. The bearings are self lubricating and therefore maintenance free over the life of the table.

Deep Channel Extruded Body
Provides significant beam strength, stiffness and is machined to provide exceptional straightness and flatness.



HD Series Life/Load Performance

The following performance information is provided as a supplement to the product specifications pages. The following graphs are used to establish the table life relative to the applied loads. The useful life of a linear table at full catalog specifications is dependent on the forces acting upon it. These forces include both static components resulting from payload weight and dynamic components due to acceleration/deceleration of the load. In multi-axes applications, the primary positioner at the bottom of the stack usually establishes the load limits for the combined axes. When determining life/load, it is critical to include the weight of all positioning elements that contribute to the load supported by the primary axis.

These charts are to be used in conjunction with the corresponding formulas found in the product manuals at www.parkermotion.com to establish the life/load for each bearing (4 per table).

Several dimensions, which are specific to each linear positioning table model, and the load geometry are required for these computations. These dimensions are supplied in the catalog information for each positioner. The dimensions are referenced as follows:

- d1 – bearing block center-to-center longitudinal spacing
- d2 – bearing rail center-to-center lateral spacing
- d3 – Rail center-to-carriage mounting surface

Refer to Parker's website www.parkermotion.com for moment loading and other engineering data.

Table Life/Load Compression (Normal) Load

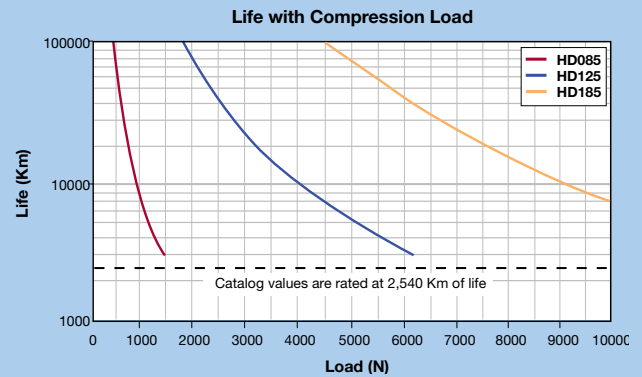

This graph provides evaluation of the support bearing life/load characteristics. The curves show the life/load relationship when the applied load is centered on the carriage, normal (perpendicular) to the carriage mounting surface.

For final evaluation of life vs load, including off center, tension, and side loads, refer to the charts and formulas found at www.parkermotion.com.

	d1	d2	d3
HD085	51	42	53.5
HD125	65	70	57.5
HD185	105	115	42.0

Screw Driven Tables

Bearing Life with Compression or Tension Load

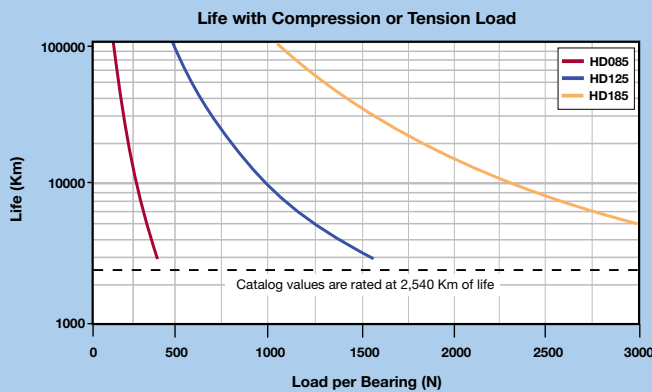

Bearing Life with Side Load

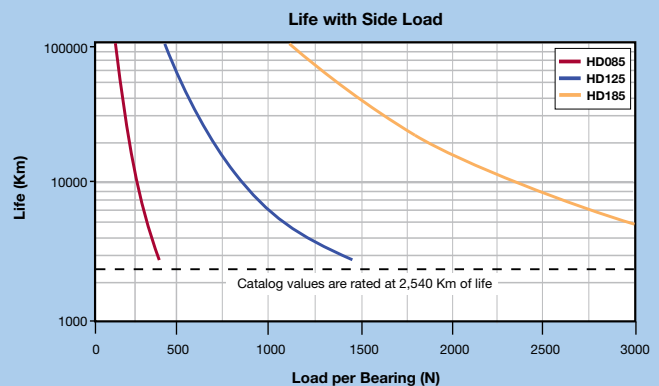

**HD085 Series Linear Table
85 mm Wide Profile**

Common Characteristics

Performance	Standard	Industrial
Bidirectional Repeatability ⁽¹⁾ – (µm)	±8.0	±50.0
Duty Cycle	100%	100%
Max Acceleration – m/sec ² (in/sec ²)	20 (773)	20 (773)
Rated Normal Load ⁽²⁾ – kgf (lbs)	170 (374)	170 (374)
Rated Axial Loading ⁽³⁾ – kgf (lbs)	90 (198)	90 (198)
Drive Screw Efficiency – %	90	90
Max. Breakaway Torque – Nm (ft-lbs)	0.21 (0.15)	0.21 (0.15)
Running Torque – Nm (ft-lbs)	0.18 (0.13)	0.18 (0.13)
Linear Bearing Coefficient of Friction	0.01	0.01
Carriage Weight – kg (lbs)	0.9 (1.98)	0.9 (1.98)



Travel Dependent Characteristics

Travel	Positional Accuracy ⁽¹⁾ (µm)		Straightness & Flatness Accuracy (µm)		Max. Velocity (mm/sec.)			Input Inertia (kg-m ² x 10 ⁻⁹)			Total Table Weight (kg)
	Standard	Industrial	Standard	Industrial	5 mm	10 mm	20 mm	5 mm	10 mm	20 mm	
100	25	50	10	20	370	740	1480	1.826	1.925	2.322	3.86
200	25	50	15	30	370	740	1480	2.214	2.313	2.710	4.56
300	30	75	20	40	370	740	1480	2.601	2.701	3.097	5.26
400	35	100	25	50	370	740	1480	2.989	3.088	3.485	5.96
500	40	120	30	60	370	740	1480	3.377	3.476	3.873	6.66
600	45	130	35	70	260	520	1040	3.764	3.864	4.260	7.36
800	55	150	45	90	180	360	720	4.540	4.639	5.036	8.76
1000	65	200	55	110	—	240	480	—	5.414	5.811	10.16
1200	75	250	65	130	—	170	340	—	6.190	6.586	11.56

Motor Characteristics

	M01x M02x SM232AE	M11x M12x SM232AQ	M100 Series* HV232	M100 Parallel* HV232
Max. Voltage	340	340	170	170
Peak Current	8.3	8.3	1.38	2.76
RMS Current	2.0	2.0	1.38	2.76
Resistance	7.50	7.50	3.41	0.85
Inductance	2.90	2.90	12.28	3.07
Recommended Drive	S025	AR-04	E-AC	E-AC

* Series/Parallel denotes wiring of step motor to drive

(1) Accuracy and Repeatability apply to in-line motors only. Contact factory for parallel motor configurations. The accuracy and repeatability shown are for mechanics only and assume no error contribution from the motor. With standard 4000 count encoders an additional error must be added to both the accuracy and repeatability. For 5 mm lead add 1.25 microns, for 10 mm leads add 2.5 microns and for 20 mm leads add 5 microns of error to the accuracy and repeatability value stated above.

(2) Normal load capacities apply to centralized load on the linear bearing to a life of 2540 Km. Refer to life/load charts to determine life of your particular application. Normal load capacity ratings are to be used as a reference of linear bearing load to life rating. This value SHOULD NOT be used as a safe loading value since other application factors (such as mounting) affect the safe load rating.

(3) Axial load capacities assumes an average axial load on a 10 mm lead ball screw and a life of 2540 Km. Refer to life/load charts to determine life of your particular application.



HD085 Thrust versus Velocity

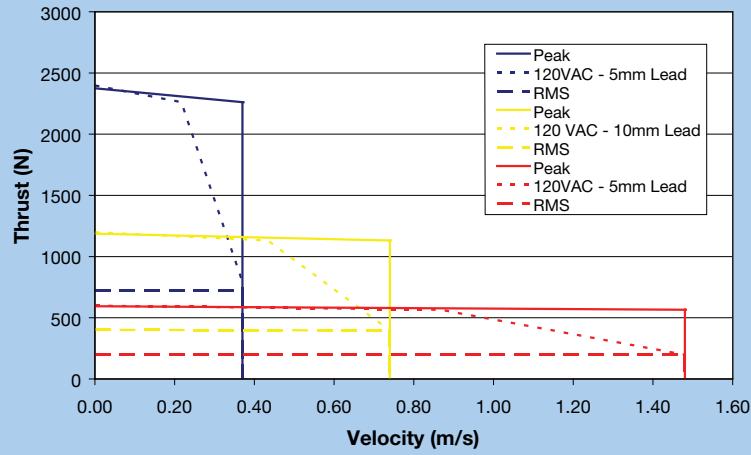

HD085 Inertia Ratios

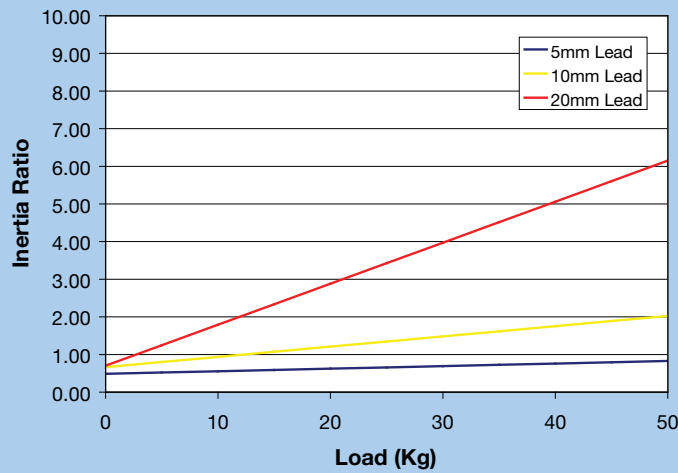

HD085 Acceleration Rates

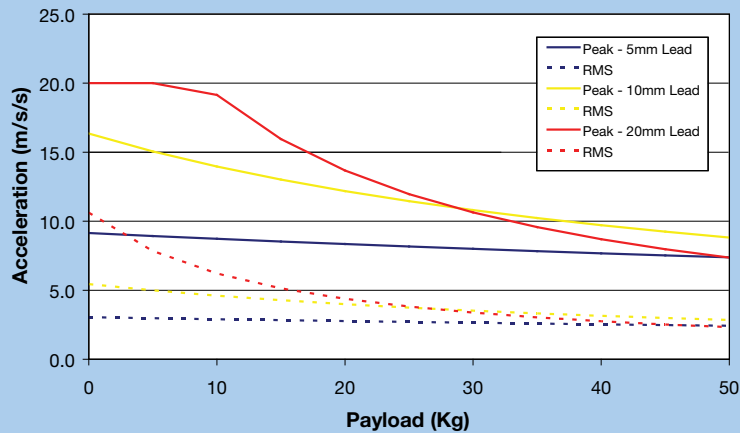

HD125 Series Linear Table
125 mm Wide Profile

Common Characteristics

Performance	Standard	Industrial
Bidirectional Repeatability ⁽¹⁾ – (µm)	±8.0	±50.0
Duty Cycle	100%	100%
Max Acceleration – m/sec ² (in/sec ²)	20 (773)	20 (773)
Rated Normal Load ⁽²⁾ – kgf (lbs)	630 (1390)	630 (1390)
Rated Axial Loading ⁽³⁾ – kgf (lbs)	90 (198)	90 (198)
Drive Screw Efficiency – %	90	90
Max. Breakaway Torque – Nm (ft-lbs)		
0 to 1000 mm Travel	0.25 (0.18)	0.25 (0.18)
1200 to 1500 mm Travel	0.35 (0.26)	0.35 (0.26)
Running Torque – Nm (ft-lbs)		
0 to 1000 mm Travel	0.21 (0.15)	0.21 (0.15)
1200 to 1500 mm Travel	0.32 (0.24)	0.32 (0.24)
Linear Bearing Coefficient of Friction	0.01	0.01
Carriage Weight – kg (lbs)	2.2 (4.84)	2.2 (4.84)



Travel Dependent Characteristics

Travel	Positional Accuracy ⁽¹⁾ (µm)		Straightness & Flatness Accuracy (µm)		Max. Velocity (mm/sec.)				Input Inertia (kg-m ² x 10 ⁻⁹)				Total Table Weight (kg)
	Std	Ind	Std	Ind	5 mm	10 mm	20 mm	40 mm	5 mm	10 mm	20 mm	40 mm	
200	25	50	15	30	370	740	1480	2240	3.061	3.416	4.834	14.386	11.50
300	30	75	20	40	370	740	1480	2240	3.449	3.804	5.222	15.612	12.75
400	35	100	25	50	370	740	1480	2240	3.837	4.191	5.610	16.837	14.00
500	40	120	30	60	315	630	1260	2240	4.224	4.579	5.997	18.062	15.25
600	45	130	35	70	240	480	960	1920	4.612	4.967	6.385	19.287	16.50
800	55	150	45	90	155	310	620	1240	5.387	5.742	7.160	7.936	19.00
1000	65	200	55	110	—	212	424	848	—	6.517	7.936	24.189	21.50
1200	75	200	65	130	—	—	420	840	—	—	21.577	27.251	24.00
1500	90	300	80	150	—	—	280	560	—	—	25.253	30.927	25.75

Motor Characteristics

	M01x M02x SM232AE	M11x M12x SM232AQ	M03x SM233AE	M13x SM233AQ	M04x MPP921B	M14x MPP921B	M100 Series* HV232	M100 Parallel* HV232
Max. Voltage	340	340	340	340	340	340	170	170
Peak Current	8.3	8.3	8.1	8.1	7.0	7.0	1.38	2.76
RMS Current	2.0	2.0	1.9	1.9	1.8	1.8	1.38	2.76
Resistance	7.50	7.50	9.65	9.65	11.0	11.0	3.41	0.85
Inductance	2.90	2.90	4.08	4.08	47.0	47.0	12.28	3.07
Recommended Drive	S025	AR-04	S025	AR-04	S025	AR-04	E-AC	E-AC

* Series/Parallel denotes wiring of step motor to drive

(1) Accuracy and Repeatability apply to in-line motors only. Contact factory for parallel motor configurations. The accuracy and repeatability shown are for mechanics only and assume no error contribution from the motor. With standard 4000 count encoders an additional error must be added to both the accuracy and repeatability. For 5 mm lead add 1.25 microns, for 10 mm leads add 2.5 microns and for 20 mm leads add 5 microns of error to the accuracy and repeatability value stated above.

(2) Normal load capacities apply to centralized load on the linear bearing to a life of 2540 Km. Refer to life/load charts to determine life of your particular application. Normal load capacity ratings are to be used as a reference of linear bearing load to life rating. This value SHOULD NOT be used as a safe loading value since other application factors (such as mounting) affect the safe load rating.

(3) Axial load capacities assumes an average axial load on a 10 mm lead ball screw and a life of 2540 Km. Refer to life/load charts to determine life of your particular application.





HD125 Series Performance

HD125 Thrust versus Velocity

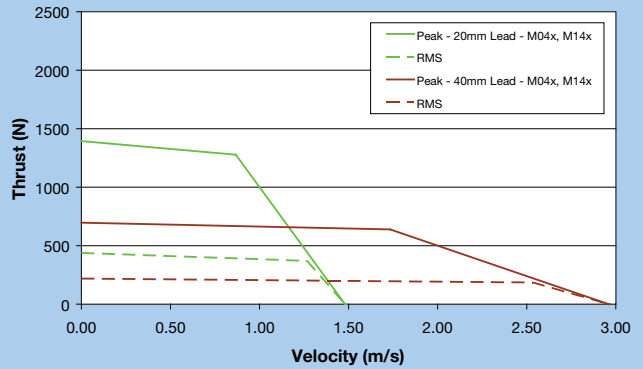
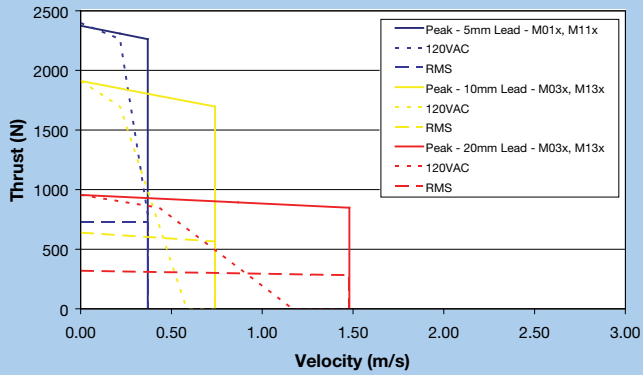

Screw Driven Tables

HD125 Inertia Ratios

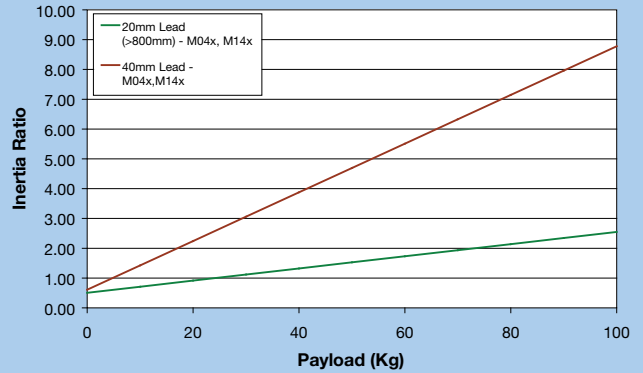
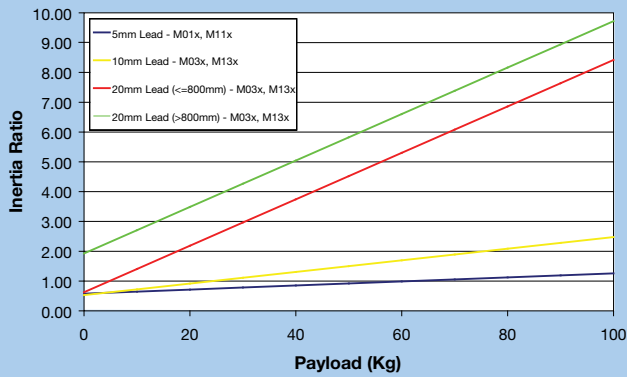

HD125 Acceleration Rates

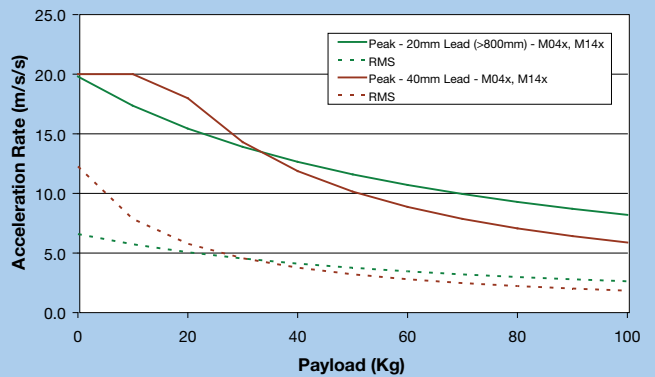
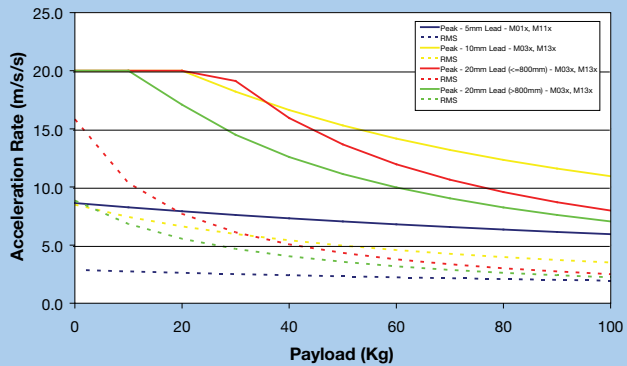

**HD185 Series Linear Table
185 mm Wide Profile**

Common Characteristics

Performance	Standard	Industrial
Bidirectional Repeatability ⁽¹⁾ – (µm)	±8.0	±50.0
Duty Cycle	100%	100%
Max Acceleration – m/sec ² (in/sec ²)	20 (773)	20 (773)
Rated Normal Load ⁽²⁾ – kgf (lbs)	1470 (3241)	1470 (3241)
Rated Axial Loading ⁽³⁾ – kgf (lbs)	90 (198)	90 (198)
Drive Screw Efficiency – %	90	90
Max. Breakaway Torque – Nm (ft-lbs)		
0 to 1000 mm Travel	0.32 (0.24)	0.32 (0.24)
1200 to 1600 mm Travel	0.38 (0.28)	0.38 (0.28)
Running Torque – Nm (ft-lbs)		
0 to 1000 mm Travel	0.21 (0.15)	0.21 (0.15)
1200 to 1600 mm Travel	0.35 (0.26)	0.35 (0.26)
Linear Bearing Coefficient of Friction	0.01	0.01
Carriage Weight – kg (lbs)	3.6 (7.92)	3.6 (7.92)



Travel Dependent Characteristics

Travel	Positional Accuracy ⁽¹⁾ (µm)		Straightness & Flatness Accuracy (µm)		Max. Velocity (mm/sec.)				Input Inertia (kg-m ² x 10 ⁻⁹)				Weight (kg)
	Std	Ind	Std	Ind	5 mm	10 mm	20 mm	40 mm	5 mm	10 mm	20 mm	40 mm	
300	30	75	20	40	370	740	1480	2240	3.446	4.174	7.087	23.178	22.9
400	35	100	25	50	370	740	1480	2240	3.833	4.562	7.475	24.403	24.6
500	40	120	30	60	355	710	1420	2240	4.221	4.949	7.862	25.628	26.4
600	45	130	35	70	270	540	1080	2000	4.609	5.337	8.250	26.854	28.2
800	55	150	45	90	165	330	660	1320	5.384	6.112	9.025	29.304	31.7
1000	65	200	55	110	—	230	460	920	—	6.888	9.801	31.754	35.2
1200	75	235	65	130	—	—	440	880	—	—	22.253	34.205	38.7
1400	85	250	75	150	—	—	340	680	—	—	25.003	36.655	42.2
1600	95	300	85	180	—	—	260	520	—	—	27.454	39.106	45.8

Motor Characteristics

	M01x SM232AE	M11x SM232AQ	M03x SM233AE	M13x SM233AQ	M04x MPP921B	M14x MPP921B
Max. Voltage	340	340	340	340	340	340
Peak Current	8.3	8.3	8.1	8.1	7.0	7.0
RMS Current	2.0	2.0	1.9	1.9	1.8	1.8
Resistance	7.50	7.50	9.65	9.65	11.0	11.0
Inductance	2.90	2.90	4.08	4.08	47.0	47.0
Recommended Drive	S025	AR-04	S025	AR-04	S025	AR-04

* Series/Parallel denotes wiring of step motor to drive

(1) Accuracy and Repeatability apply to in-line motors only. Contact factory for parallel motor configurations. The accuracy and repeatability shown are for mechanics only and assume no error contribution from the motor. With standard 4000 count encoders an additional error must be added to both the accuracy and repeatability. For 5 mm lead add 1.25 microns, for 10 mm leads add 2.5 microns and for 20 mm leads add 5 microns of error to the accuracy and repeatability value stated above.

(2) Normal load capacities apply to centralized load on the linear bearing to a life of 2540 Km. Refer to life/load charts to determine life of your particular application. Normal load capacity ratings are to be used as a reference of linear bearing load to life rating. This value SHOULD NOT be used as a safe loading value since other application factors (such as mounting) affect the safe load rating.

(3) Axial load capacities assumes an average axial load on a 10 mm lead ball screw and a life of 2540 Km. Refer to life/load charts to determine life of your particular application.





HD185 Series Performance

HD185 Thrust versus Velocity

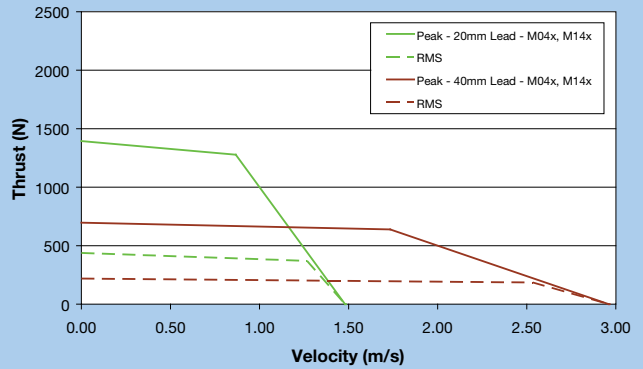
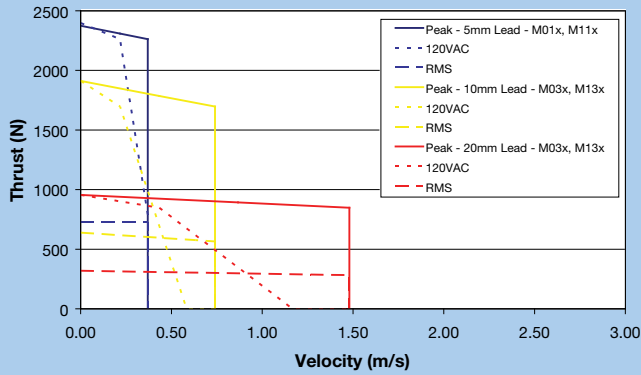

Screw Driven Tables

HD185 Inertia Ratios

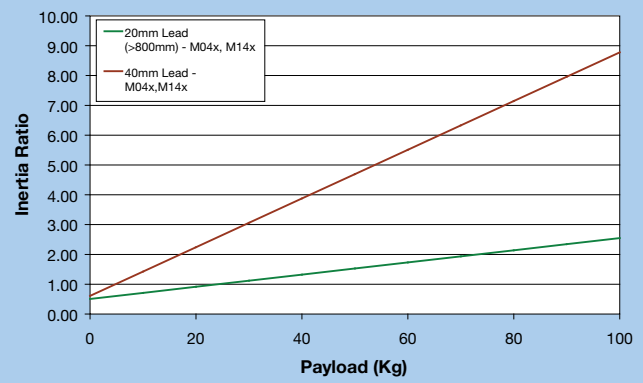
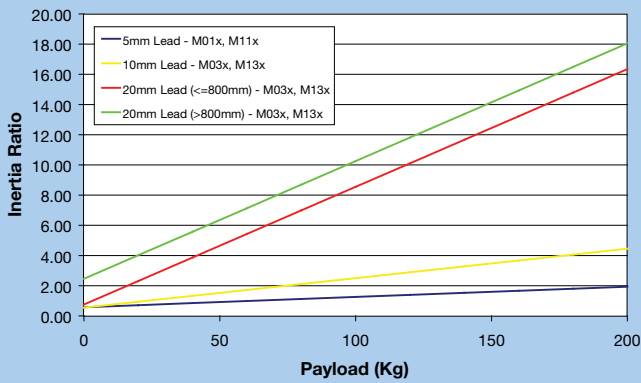

HD185 Acceleration Rates

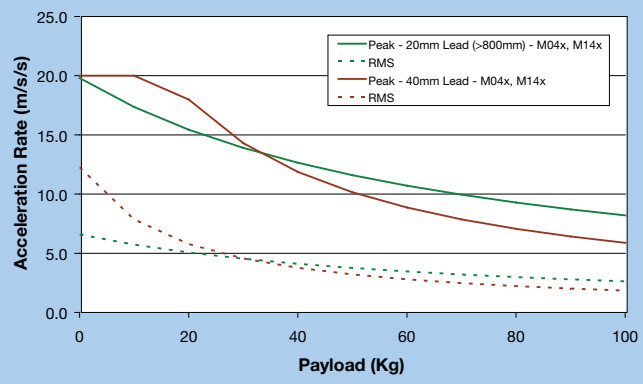
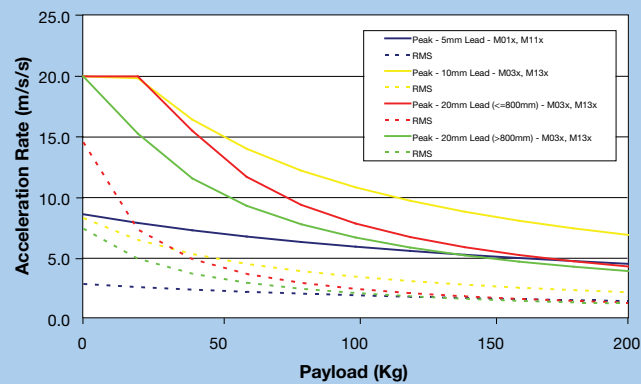

HD Series Features and Options

Deep Channel Extruded Body

The foundation of the HD Series is an extruded body, designed to provide exceptional beam strength and rigidity with ease of use features, yet be aesthetically appealing. The extrusion cross section has a high moment of inertia that strengthens and stiffens the unit. This enables users to span unsupported distances or cantilever the axis with minimal or no need for stiffening brackets. As an example, an HD may be toe clamped directly to the structural beams in a machine frame as opposed to having a plate cut to size and machined flat to serve as the positioner's mounting surface. The elimination of the mounting plate reduces overall design time and machine cost.



Precision Machined Tolerances

The extruded base provides the basic shape of the positioner but in its raw form, lacks the precision needed for most applications. Parker's proprietary machining processes are used to cut rail seats and flatten the bottom of the extrusion to specifications better than jig plate. Some manufacturers will skip machining the bottom mounting surface to save cost but sacrifice precision and risk binding and other application problems. With the HD Series you gain the feature benefits of an extruded base and through Parker's machining capability, gain precision better than jig plate designs can offer.



Maintenance Free Linear Bearings

Supporting the payload in the HD Series is a precision ground linear bearing set that offers precise, smooth motion. The two-rail, four-bearing truck design provides high load capacity and is structured to handle cantilevered load unlike single rail designs. The linear bearings are self lubricating and therefore will not require re-lubrication for the life of the table.



IP30 Rated Environmental Protection

Often automation applications can be in dirty environments. For this reason the HD Series includes environmental protection beyond just a simple plate. The HD Series uses a combination of hard cover and belt seal to provide a significant level of environmental protection for the tables internal components. This is ideal for larger objects like nuts, bolts, fingers, and larger debris. The sealing system will provide a measure of protection for dust but is not impervious. For these applications, pressurizing the HD positioner can be very effective.



High-Performance Brushless Servo Motors

Included with the HD Series are high-performance brushless servo motors. These motors are performance-matched with the mechanical drive train and are inertia matched to maintain good load-to-rotor inertia ratios. Together, these characteristics offer excellent dynamic performance and stability.



As standard, the motors are offered in an in-line configuration and for space constrained applications may be mounted in a parallel configuration. The parallel design utilizes a belt and pulley to transfer torque and includes additional pulley support bearings to protect the motor shaft and screw shank from over tension and fatigue failures.

Finally, because the motors are included, system performance can be pre-calculated and presented in graphical form. For most applications, motor sizing is as simple as looking at a graph.

Zero Backlash Shaft Coupling

Included with the HD Series to transfer motor torque to the ballscrew is a high-performance shaft coupling. The coupling design uses stainless steel disks to transfer torque yet provide a measure of flexibility for slight shaft misalignments. The design is very lightweight and adds minimal inertia. The combination of high stiffness and low inertia maintains high natural frequencies, which is important for high performance applications.





Ground Ballscrew Drive Train (Standard Grade)

At the heart of the HD Series drive train is a preloaded, precision ground ballscrew. This high-performance component offers high-speed, 100% duty cycle operation with long life, plus the better precision and surface finish of a ground screw compared with a rolled screw enables more accurate and quieter operation.



As standard, the HD Series offers 5 mm, 10 mm, and 20 mm lead options with a 40 mm lead available as a special. For most travels, the screws are 15 mm in diameter with the longer 20 mm lead and all 40 mm lead screws increasing to 20 mm in diameter. Like the linear bearings, the screws are self lubricating and will not require re-lubrication for the table's life.

Mounting Features

The HD Series is designed for easy mounting. There are two basic methods of mounting an HD module into a machine. First, toe clamps (Part Number 101-2577-01) provide an easy method of bolting the HD down to a surface. For maximum flexibility, the toe clamps can be placed anywhere along the body extrusion and enable aligning mounting points with structural members of the machine frame. The second method utilizes tapped holes in the base where the mounting hardware comes through the mounting surface into the HD module. The mounting pattern consists 4 tapped holes and 2 dowel holes and repeats at varying intervals depending on overall travel. See the HD Series drawings for hole location details.



Dowel Holes

As mentioned above the base of the HD Series includes dowel holes. These enable repeatable mounting within a machine. Further, the carriage of the HD also includes a set of dowel holes and is very useful for maintaining alignment if the payload is removed or replaced.



End Mounting

In many applications, the positioner may be mounted with the carriage stationary such that the body moves. For these applications, the end of the HD includes tapped and dowel holes for mounting of the payload to the HD body. In many cases this avoids the cost and time of designing an awkward bracket to wrap from the bottom of the positioner around to the end.



Home and Limit Sensors

As a standard option, home and end of travel limit sensors may be added to an HD positioner. These are industrially hardened, hall effect sensors that are triggered by a magnet mounted on the moving carriage. The sensors nest inside the extrusion T-slot and so do not add additional width or create obstructions. Further they are protected inside the T-slot which minimizes the opportunity for physical damage.



For maximum flexibility, sensors are adjustable over the entire length and magnets are included on both sides of the table so sensors can be attached on either side. The sensors are offered in 4 variants with NPN (sinking) or PNP (sourcing) outputs and in normally open (NO) or normally closed (NC) logic. The sensor cables extend 300 mm and terminate into a M3 connector. If purchased as part of the positioner (LH option) each sensor will include a 5 m extension cable (P/N: 003-2918-01).

Input Power	10-30VDC
Voltage Drop	<= 2.5V
Cont. Current	100mA
Electrical Protection	Short Circuit, Reverse Polarity, Power Up Pulse Suppression
Enclosure	IP67 Rated Polyamide Housing with PVC Cable Jacket
Wire Colors	Brown – Power (+) Black – Signal Blue – Ground (-)
Repeatability	0.1 mm max

Spare Part Number	Output Type	Logic	Cable Type
006-1994-01	N.O.	NPN (Sinking)	300 mm to M3 connector
006-1994-02	N.O.	PNP (Sourcing)	300 mm to M3 connector
006-1994-03	N.C.	NPN (Sinking)	300 mm to M3 connector
006-1994-04	N.C.	PNP (Sourcing)	300 mm to M3 connector
003-2918-01	—	—	5.0 m Extension Cable

Screw Driven Tables

HD085 Series Dimensions

Dimensions (mm)

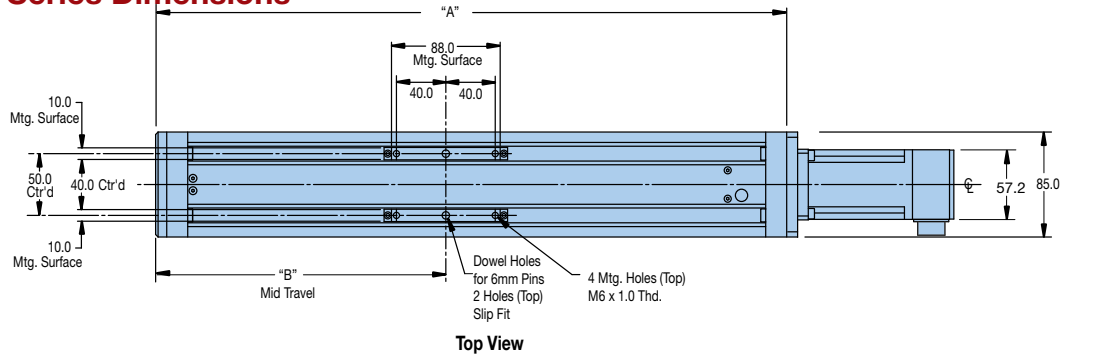

Top View

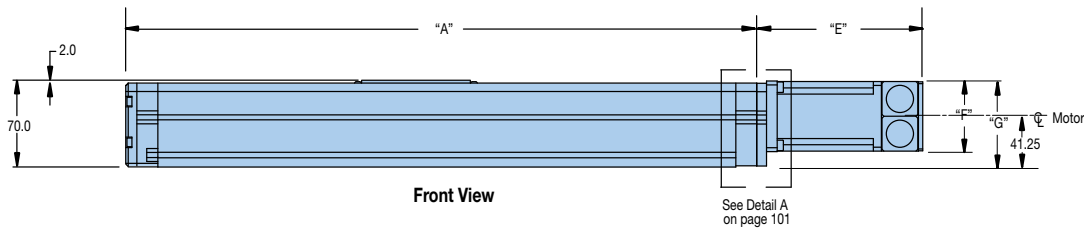

Front View

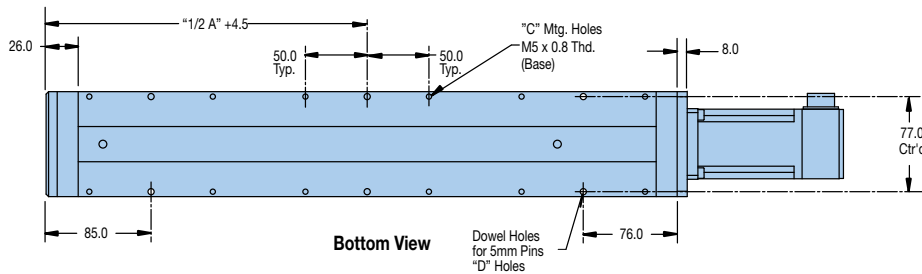

Bottom View

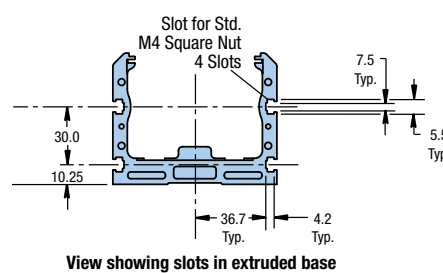
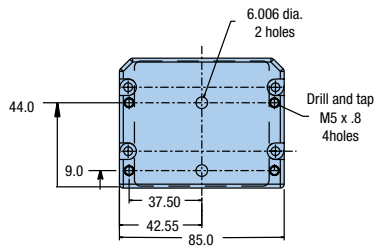

View showing slots in extruded base

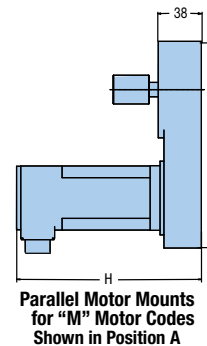

Parallel Motor Mounts
for "M" Motor Codes
Shown in Position A

Model	Dimensions					
	Travel	A	B	C	D	E
HD085T01	100	311	135	4	2	160
HD085T02	200	411	185	12	6	210
HD085T03	300	511	235	12	6	260
HD085T04	400	611	285	12	6	310
HD085T05	500	711	335	12	6	360
HD085T06	600	811	385	12	6	410
HD085T07	700	911	435	12	6	460
HD085T08	800	1011	485	12	6	510
HD085T09	900	1111	535	12	6	560
HD085T10	1000	1211	585	12	6	610
HD085T11	1100	1311	635	12	6	660
HD085T12	1200	1411	685	12	6	710

See addendum page 100A
for additional new
parallel motor mounts.

Motor Model	Dimensions			
	E	F	G	H
M000	No Motor	0	-	-
M010	SM232AE-TPSN	134.5	57.2	69.8
M020	SM232AE-TPSB	168.0	57.2	69.8
M100	HV232-D2-10	79.2	57.2	69.8
M110	SM232AQ-TPSN	134.5	57.2	69.8
M020	SM232AQ-TPSB	168.0	57.2	69.8

New HD085 Parallel Motor Options

Dimensions (mm)

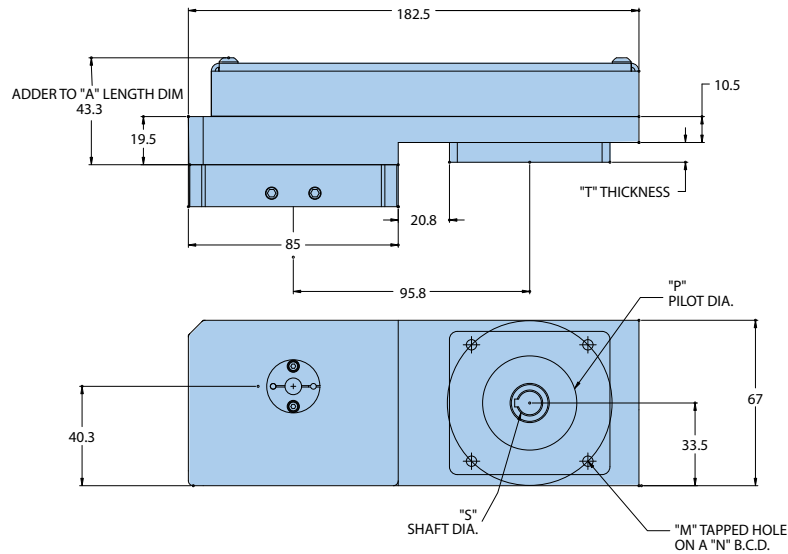

NOTE : SHOWN AS SIDE "A" ("B" IS MIRROR IMAGE . ROTATED 180° ABOUT TABLE SCREW CENTERLINE)

Motor Adapter Assembly Part Number	Dimensions				Example Motors
	M	P	S	T	
A011-HD085 or B011-HD085	M4 x 0.7	30.0	8.0	6.5	Yaskawa SGMAH-01, SGM-01 Kollmorgen AKM1X-AN Allen Bradley Y-1002, Y-1003
A232-HD085 or B232-HD085	M5 x 0.8	38.1	9.53	8.0	Parker SM23X , BE23X



HD085 Motor Flange/Coupling Assembly Options

Dimensions (mm)

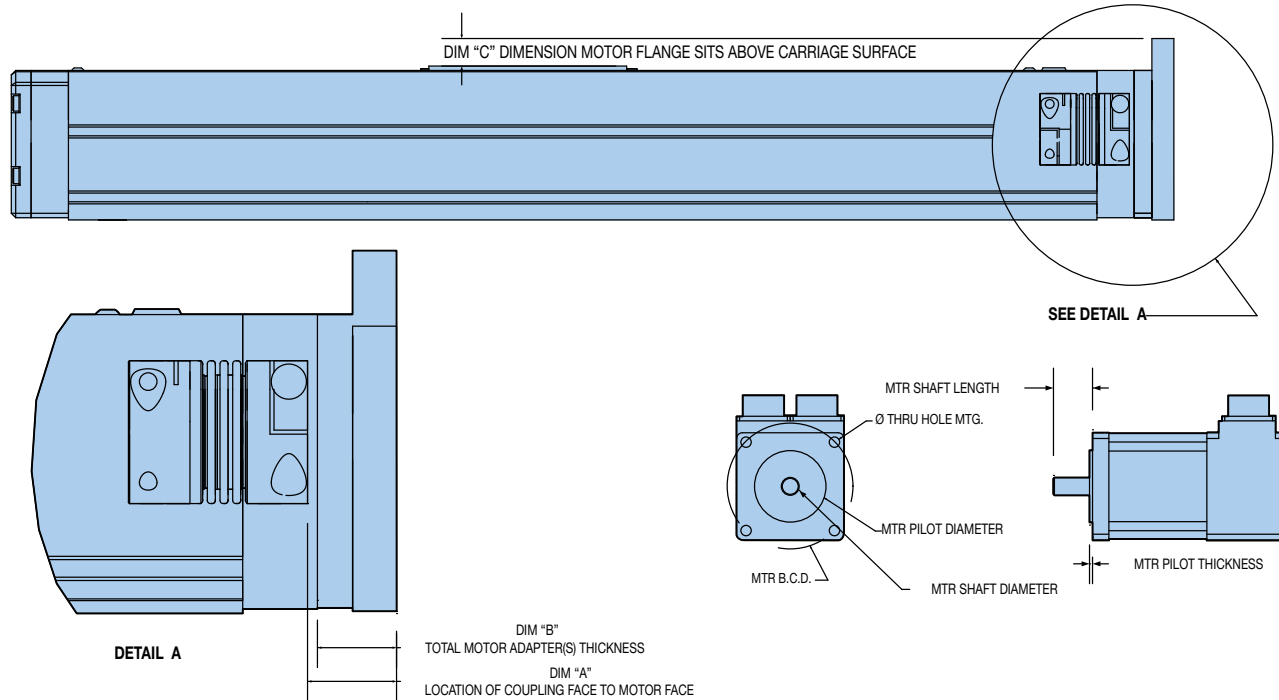

Screw Driven Tables

Motor Adapter Assembly Part Number	Dimensions			Required Motor Specifications						Example Motors
	A	B	C	Pilot Dia.	Pilot Depth	Bolt Circle Dia.	Bolt Hole Size	Shaft Dia.	Shaft Length	
F011-HD085	12.0	8.0	—	30.0	3.0	46.0	4.5	8.0	25.0	Yaskawa SGMAH-01, SGM-01 Kollmorgen AKM1X-AN Allen Bradley Y-1002, Y-1003
F012-HD085	12.0	8.0	—	30.0	3.0	46.0	4.5	6.0	25.0	Yaskawa SGMAH-A1XXF4, SGMAH-A3XXF4X, SGM-03, SGM-A5
F021-HD085	15.0	10.5	—	50.0	3.0	60.0	4.5	8.0	24.0	Allen Bradley LD-2003
F031-HD085	12.0	8.0	—	40.0	3.0	63.0	5.5	9.0	20.0	Parker SMB60/HDY55 Allen Bradley MPL1510/1520/1530
F041-HD085	12.0	8.0	—	40.0	3.0	63.0	4.5	9.0	20.0	Kollmorgen AKM2X-AN Indramat MKD025
F051-HD085	15.0	10.5	—	50.0	3.0	70.0	5.5	8.0	25.0	Yaskawa SGMP-01, SGMPH-01-XXXX
F061-HD085	20.0*	18.0	1.3	50.0	3.0	70.0	5.5	14.0	30.0	Yaskawa SGMAH-02XXF4X, SGMAH-04XXF4X, SGM-02, SGM-04 Allen Bradley Y-2006, Y-2012
F071-HD085	10.0*	10.5	2.0	60.0	3.0	75.0	5.5	11.0	23.0	Parker J070/NO70/HDY70 Allen Bradley MPL210/220/230 Kollmorgen B102/BH-122
F072-HD085	10.0*	10.5	2.0	60.0	3.0	75.0	5.5	14.0	30.0	Kollmorgen B104/B106, M-103/105/107, AKM3X-AN, BH-124/126
N231-HD085	12.0	8.0	—	38.1	3.0	66.675	5.5	6.35	20.0	Parker ES23X Allen Bradley N-2302, N-2304
N232-HD085	12.0	8.0	—	38.1	3.0	66.675	5.5	9.525	20.0-31.0	Animatics SM2310D, SM2320D Parker SM23X, BE23X
N233-HD085	10.0*	8.0	—	38.1	3.0	66.675	4.5	12.7	20.0	Yaskawa SGMAH-0XXN2XX, SGMAH-04XXN2XX NEMA 23 Face
N341-HD085	20.0*	18.0	12.6	73.03	3.0	98.425	5.5	12.5	37.0	Parker HV/LV34

* Note: Coupling must be mounted to motor first. Distance of coupling face to motor face.

HD125 Series Dimensions

Dimensions (mm)

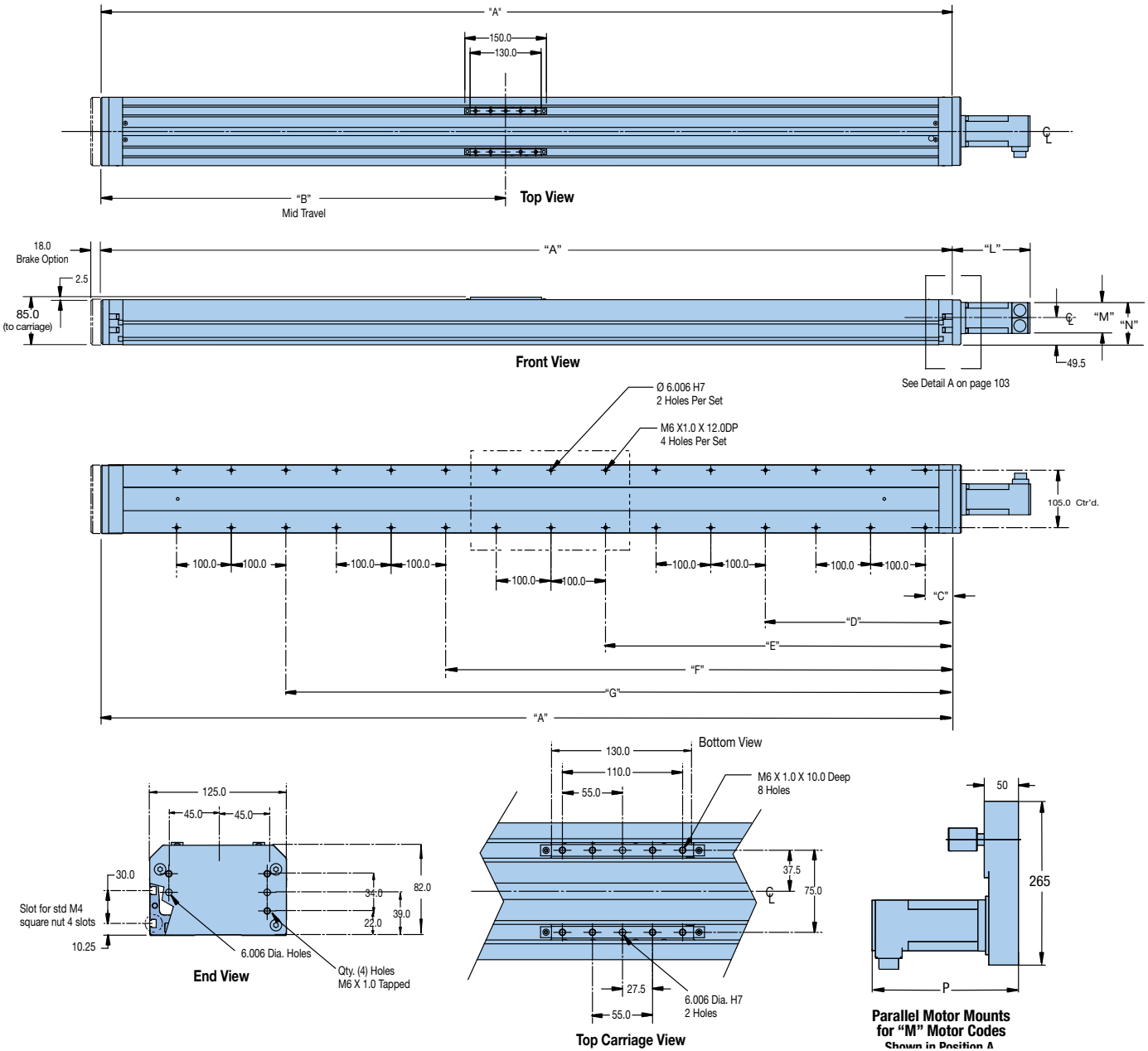

Model	Travel	Dimensions						
		A	B	C	D	E	F	G
HD125T02	200	508.0	239.5	-	-	135.0	-	-
HD125T03	300	608.0	289.5	50.0	-	185.0	-	320.0
HD125T04	400	708.0	339.5	50.0	-	235.0	-	420.0
HD125T05	500	808.0	389.5	50.0	-	285.0	-	520.0
HD125T06	600	908.0	439.5	50.0	-	335.0	-	620.0
HD125T08	800	1108.0	539.5	50.0	-	435.0	-	820.0
HD125T10	1000	1308.0	639.5	50.0	-	535.0	-	1020.0
HD125T12	1200	1558.0	737.0	50.0	342.5	635.0	927.5	1220.0
HD125T15	1500	1858.0	887.0	50.0	417.5	785.0	1152.5	1520.0

See addendum page 102A for additional new parallel motor mounts.

Motor Model	Description	Dimensions			
		L	M	N	P
M000	No Motor	0	-	-	-
M010	SM232AE-TPSN	167	57.2	78.1	208
M030	SM233AE-TPSN	192	57.2	78.1	233
M040	CMP921B1E	195	89.4	94.2	-
M100	HV232-D2-10	102	57.2	78.1	-
M110	SM232AE-TPSN	167	57.2	78.1	208
M130	SM233AE-TPSN	192	57.2	78.1	233
M140	CMP921B3E	195	89.4	94.2	-

New HD125 Parallel Motor Options

Dimensions (mm)

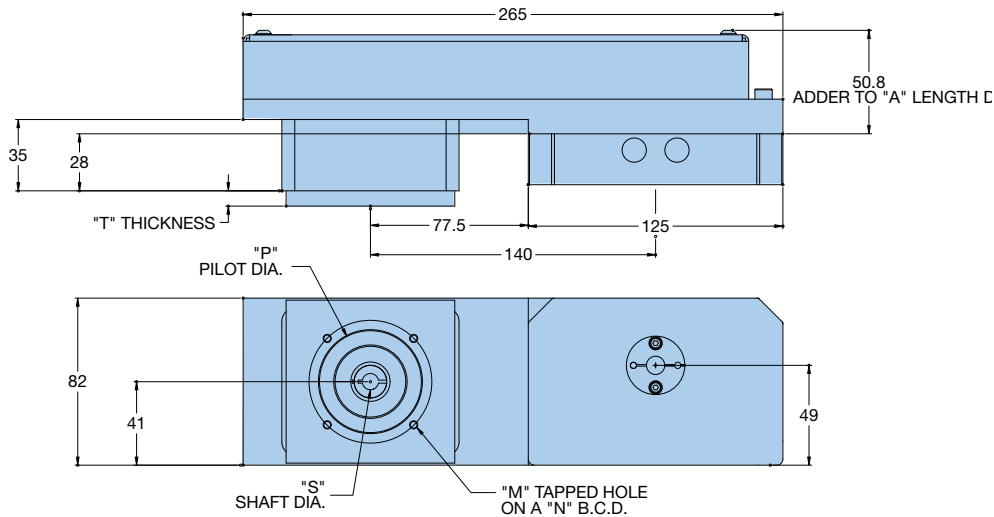

NOTE : SHOWN AS SIDE "B" ("A" IS MIRROR IMAGE . ROTATED 180° ABOUT TABLE SCREW CENTERLINE)

Motor Adapter Assembly Part Number	Dimensions					Example Motors
	M	N	P	S	T	
A021-HD125 or B021-HD125	M4 x 0.7	60.0	50.0	8.0	7.5	Allen Bradley LD-2003
A031-HD125 or B031-HD125	M5 x 0.8	63.0	40.0	9.0	7.5	Parker SMB60/HDY55 Allen Bradley MPL1510/1520/1530
A041-HD125 or B041-HD125	M4 x 0.7	63.0	40.0	9.0	7.5	Kollmorgen AKM2X-AN Indramat MKD025
A061-HD125 or B061-HD125	M5 x 0.8	70.0	50.0	8.0	10.0	Yaskawa SGMP-01, SGMPH-01-XXXX
A062-HD125 r B062-HD125	M5 x 0.8	70.0	50.0	14.0	10.0	Yaskawa SGMAH-02XXF4X, SGMAH-04XXF4X, SGM-02, SGM-04 Allen Bradley Y-2006, Y-2012
A071-HD125 or B071-HD125	M5 x 0.8	75.0	60.0	11.0	-	Parker J070/NO70/HDY70 Allen Bradley MPL210/220/230 Kollmorgen B102/BH-122
A081-HD125 or B081-HD125	M6 x 1.0	90.0	70.0	14.0	10.0	Yaskawa SGMPH-02XXX, SGMPH-04XXX, SGMP-02, SGMP-04
A101-HD125 or B101-HD125	M6 x 1.0	95.0	50.0	14.0	10.0	Indramat MKD041
A111-HD125 or B111-HD125	M6 x 1.0	100.0	80.0	14.0	10.0	Parker JO92X/NO92X
A121-HD125 or B121-HD125	M6 x 1.0	100.0	80.0	16.0	8.0*	Kollmorgen AKM4X-AN Mounting Code
A231-HD125 or B231-HD125	M5 x 0.8	66.68	38.1	6.35	10.0	Parker ES23X Allen Bradley N-2302, N-2304 Animatics SM2310D, SM2320D
A232-HD125 or B232-HD125	M5 x 0.8	66.68	38.1	9.53	10.0	Parker SM23X , BE23X
A233-HD125 or B233-HD125	M4 x 0.7	66.68	38.1	12.7	10.0	Yaskawa SGMAH-0XXN2XX, SGMAH-04XXN2XX NEMA 23 Face
A341-HD125 or B341-HD125	M5 x 0.8	98.43	73.03	6.35	15.0	Parker HV/LV34
A342-HD125 or B342-HD125	M5 x 0.8	98.43	73.03	12.7	15.0	Parker BE34

*Not outer support bearing assembly block (no 35 mm dimension pulley on motor shaft).



HD125 Motor Flange/Coupling Assembly Options

Dimensions (mm)

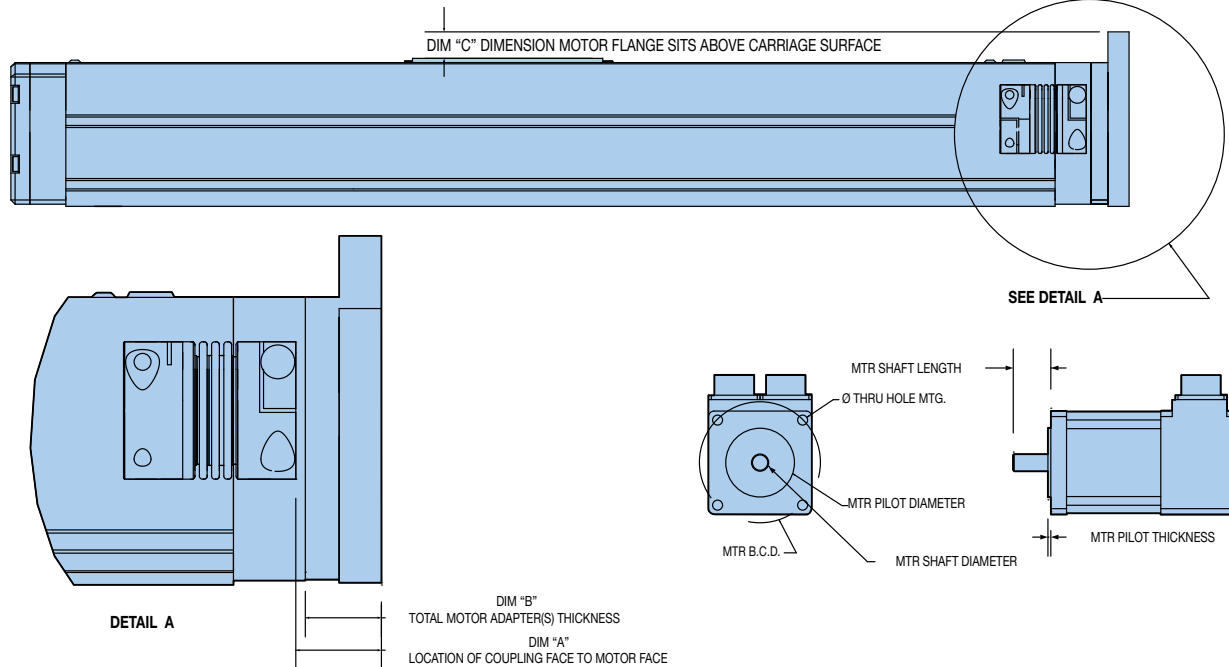

Screw Driven Tables

Motor Adapter Assembly Part Number	Dimensions			Required Motor Specifications						Example Motors
	A	B	C	Pilot Dia.	Pilot Depth	Bolt Circle Dia.	Bolt Hole Size	Shaft Dia.	Shaft Length	
F021-HD125	15.0	10.5	—	50.0	3.0	60.0	4.5	8.0	24.0	Allen Bradley LD-2003
F031-HD125	12.0	8.0	—	40.0	3.0	63.0	5.5	9.0	20.0	Parker SMB60/HDY55 Allen Bradley MPL1510/1520/1530
F041-HD125	12.0	7.5	—	40.0	3.0	63.0	4.5	9.0	20.0	Kollmorgen AKM2X-AN Indramat MKD025
F061-HD125	15.0	12.0	—	50.0	3.0	70.0	5.5	8.0	25.0	Yaskawa SGMP-01, SGMH-01-XXXX
F062-HD125	15.0	12.0	—	50.0	3.0	70.0	5.5	14.0	30.0	Yaskawa SGMAH-02XF4X, SGMAH-04XF4X, SGM-02, SGM-04 Allen Bradley Y-2006, Y-2012
F071-HD125	12.0	10.5	—	60.0	3.0	75.0	5.5	11.0	23.0	Parker J070/NO70/HDY70 Allen Bradley MPL210/220/230 Kollmorgen B102/BH-122
F072-HD125	12.0	10.5	—	60.0	3.0	75.0	5.5	14.0	30.0	Kollmorgen B104/B106, M-103/105/107, AKM3X-AN, BH-124/126
F081-HD125	15.0*	22.0	4.5	70.0	3.5	90.0	6.6	14.0	30.0	Yaskawa SGMH-02XXX, SGMPH-04XXX, SGMP-02, SGMP-04
F082-HD125	15.0*	22.0	4.5	70.0	3.5	90.0	6.6	16.0	30.0-40.0	Yaskawa SGMAH-08 SGM-08 Allen Bradley Y-3023
F091-HD125	15.0*	22.0	4.5	70.0	3.5	90.0	5.5	14.0	30.0	Allen Bradley LD-3009
F101-HD125	15.0*	22.0	7.0	50.0	3.5	95.0	6.6	14.0	30.0	Indramat MKD041
F111-HD125	15.0*	20.0	7.0	80.0	3.5	100.0	6.6	14.0	30.0	Parker JO92X/NO92X
F121-HD125	20.0*	28.0	7.0	80.0	3.5	100.0	6.6	16.0	30.0-40.0	Parker MPP92X Allen Bradley MPL310/320/330, LD-4012
F122-HD125	25.0*	33.0	7.0	80.0	3.5	100.0	6.6	19.0	40.0	Kollmorgen AKM4X-AN Mounting Code Parker ES23X
N231-HD125	12.0	8.0	—	38.1	3.0	66.675	5.5	6.35	20.0	Allen Bradley N-2302, N-2304 Aniomatics SM2310D, SM2320D
N232-HD125	12.0	8.0	—	38.1	3.0	66.675	5.5	9.525	20.0-31.0	Parker SM23X, BE23X
N233-HD125	10.0*	8.0	—	38.1	3.0	66.675	4.5	12.7	20.0	Yaskawa SGMAH-0XXN2XX, SGMAH-04XXN2XX NEMA 23 Face
N341-HD125	15.0	20.0	7.0	73.03	3.0	98.425	5.5	12.5	37.0	Parker HV/LV34
N342-HD125	15.0*	20.0	7.0	73.03	3.0	98.425	5.5	12.7	30.0	Parker BE34

* Note: Coupling must be mounted to motor first. Distance of coupling face to motor face.

HD185 Series Dimensions

Dimensions (mm)

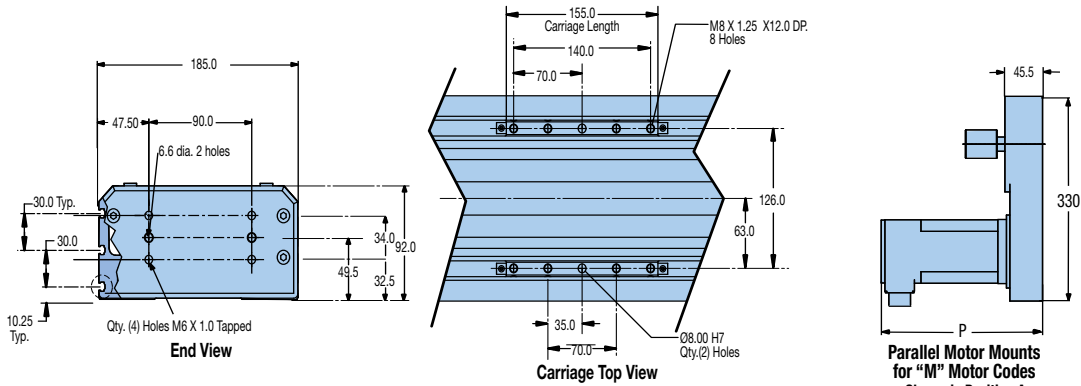
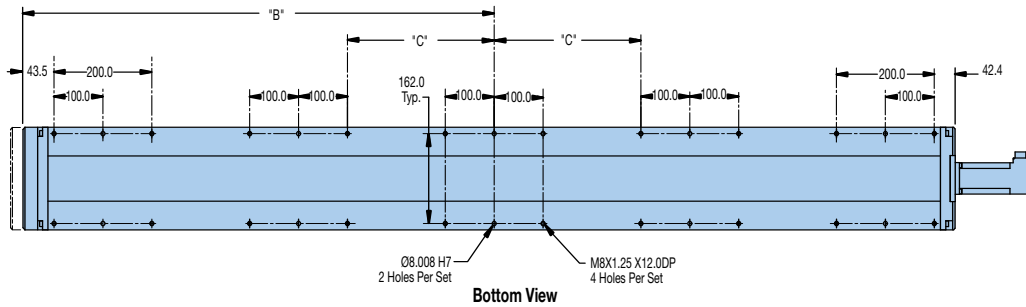
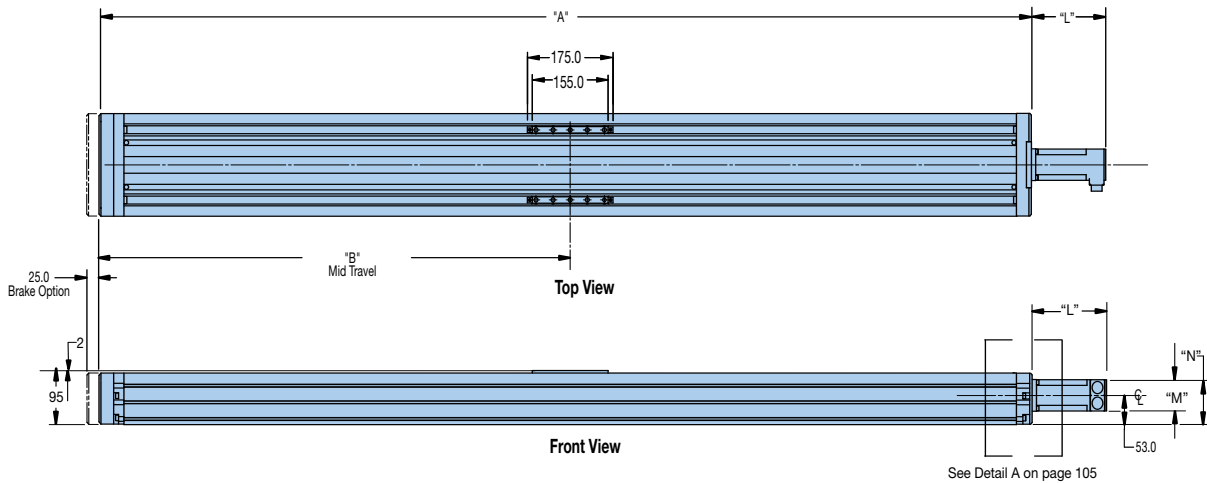

See addendum page 104A
for additional new
parallel motor mounts.

Model	Travel	Dimensions		
		A	B	C
HD185T03	300	585.9	293.5	—
HD185T04	400	685.9	343.5	—
HD185T05	500	785.9	393.5	—
HD185T06	600	885.9	443.5	—
HD185T08	800	1085.9	543.5	—
HD185T10	1000	1285.9	643.5	—
HD185T12	1200	1485.9	743.5	200.0
HD185T14	1400	1685.9	843.0	250.0
HD185T16	1600	1885.9	943.0	300.0
HD185T18	1800	2085.9	1043.0	350.0
HD185T20	2000	2285.9	1143.5	400.0

Motor Model	Motor Model	Dimensions			
		L	M	N	P
M000	No Motor	0	—	—	—
M010	SM232AE-TPSN	126.8	57.2	81.6	208
M030	SM233AE-TPSN	152.2	57.2	81.6	233
M040	CMP921B1E	170.1	89.4	91.7	207
M110	SM232AQ-TPSN	126.8	57.2	81.6	208
M130	SM233AQ-TPSN	152.2	57.2	81.6	233
M140	CMP921B3E	170.1	89.4	91.7	277

New HD185 Parallel Motor Options

Dimensions (mm)

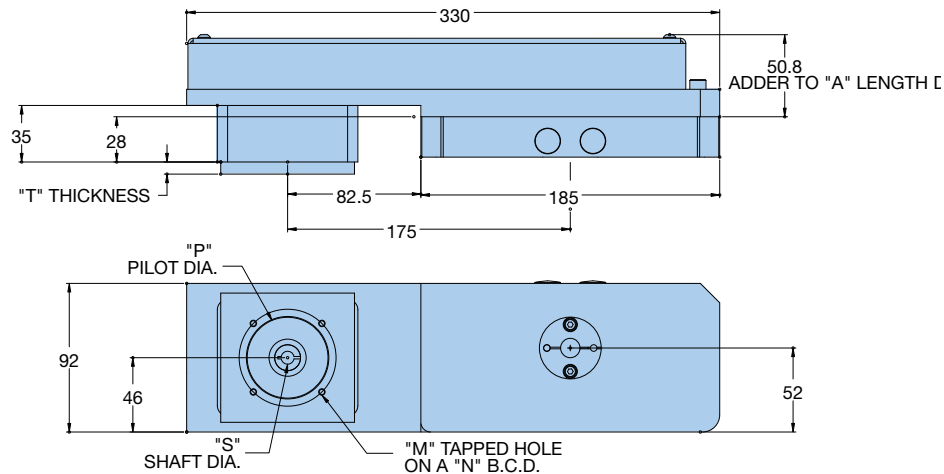

NOTE : SHOWN AS SIDE "B" ("A" IS MIRROR IMAGE . ROTATED 180° ABOUT TABLE SCREW CENTERLINE)

Motor Adapter Assembly Part Number	Dimensions					Example Motors
	M	N	P	S	T	
A021-HD185 or B021-HD185	M4 x 0.7	60.0	50.0	8.0	7.5	Allen Bradley LD-2003
A031-HD185 or B031-HD185	M5 x 0.8	63.0	40.0	9.0	7.5	Parker SMB60/HDY55 Allen Bradley MPL1510/1520/1530
A041-HD185 or B041-HD185	M4 x 0.7	63.0	40.0	9.0	7.5	Kollmorgen AKM2X-AN Indramat MKD025
A061-HD185 or B061-HD185	M5 x 0.8	70.0	50.0	8.0	10.0	Yaskawa SGMP-01, SGMPH-01-XXXX
A062-HD185 or B062-HD185	M5 x 0.8	70.0	50.0	14.0	10.0	Yaskawa SGMAH-02XXF4X, SGMAH-04XXF4X, SGM-02, SGM-04 Allen Bradley Y-2006, Y-2012
A071-HD185 or B071-HD185	M5 x 0.8	75.0	60.0	11.0	-	Parker J070/NO70/HDY70 Allen Bradley MPL210/220/230 Kollmorgen B102/BH-122
A081-HD185 or B081-HD185	M6 x 1.0	90.0	70.0	14.0	10.0	Yaskawa SGMPH-02XXX, SGMPH-04XXX, SGMP-02, SGMP-04
A082-HD185 or B082-HD185	M5 x 0.8	90.0	70.0	14.0	10.0	Yaskawa SGMAH-08 SGM-08 Allen Bradley Y-3023
A101-HD185 or B101-HD185	M6 x 1.0	95.0	50.0	14.0	10.0	Indramat MKD041
A111-HD185 or B111-HD185	M6 x 1.0	100.0	80.0	14.0	10.0	Parker JO92X/NO92X
A121-HD185 or B121-HD185	M6 x 1.0	100.0	80.0	16.0	8.0*	Parker MPP92X Allen Bradley MPL310/320/330, LD-4012
A231-HD185 or B231-HD185	M5 x 0.8	66.68	38.1	6.35	10.0	Parker ES23X Allen Bradley N-2302, N-2304 Animatec SM2310D, SM2320D
A232-HD185 or B232-HD185	M5 x 0.8	66.68	38.1	9.53	10.0	Parker SM23X , BE23X
A233-HD185 or B233-HD185	M4 x 0.7	66.68	38.1	12.7	10.0	Yaskawa SGMAH-0XXN2XX, SGMAH-04XXN2XX NEMA 23 Face
A341-HD185 or B341-HD185	M5 x 0.8	98.43	73.03	6.35	15.0	Parker HV/LV34
A342-HD185 or B342-HD185	M5 x 0.8	98.43	73.03	12.7	15.0	Parker BE34

*Not outer support bearing assembly block (no 35 mm dimension pulley on motor shaft).



HD185 Motor Flange/Coupling Assembly Options

Dimensions (mm)

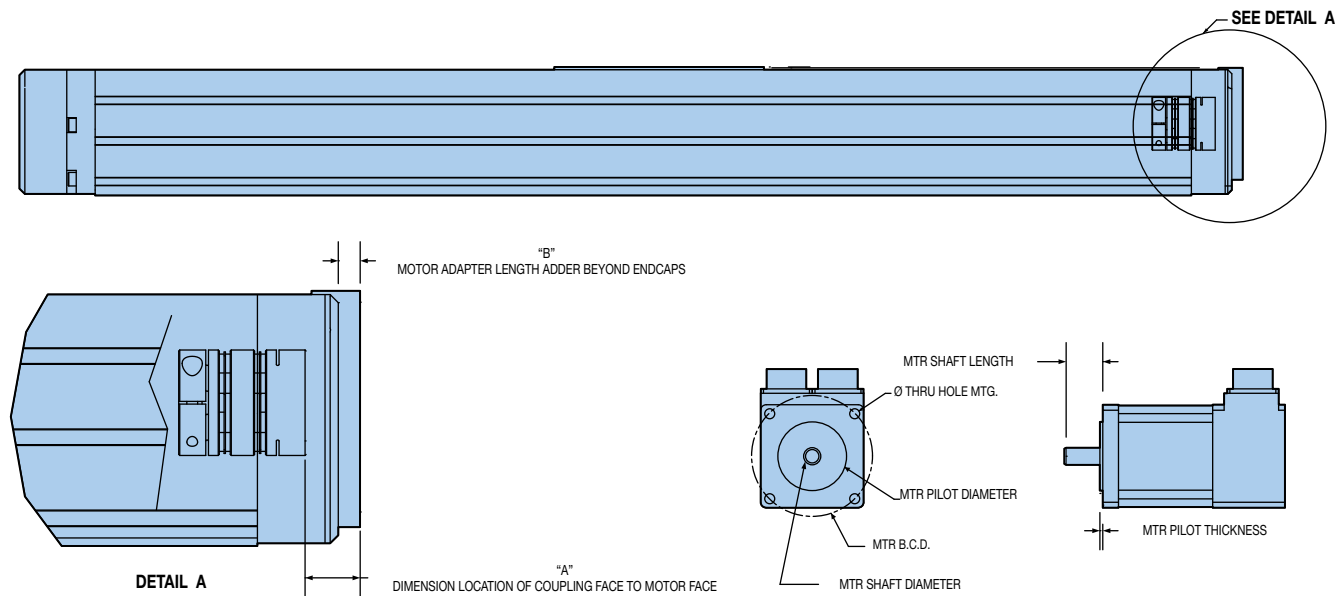

Screw Driven Tables

Motor Adapter Assembly Part Number	Dimensions		Required Motor Specifications						Example Motors
	A	B	Pilot Dia.	Pilot Depth	Bolt Circle Dia.	Bolt Hole Size	Shaft Dia.	Shaft Length	
F021-HD185	15.0	—	50.0	3.0	60.0	4.5	8.0	24.0	Allen Bradley LD-2003
F031-HD185	10.0	—	40.0	3.0	63.0	5.5	9.0	20.0	Parker SMB60/HDY55 Allen Bradley MPL1510/1520/1530
F041-HD185	10.0	—	40.0	3.0	63.0	4.5	9.0	20.0	Kollmorgen AKM2X-AN Indramat MKD025
F061-HD185	18.0	—	50.0	3.0	70.0	5.5	8.0	25.0	Yaskawa SGMP-01, SGMPH-01-XXXX Yaskawa SGMAH-02XF4X, SGMAH-04XF4X, SGM-02, SGM-04
F062-HD185	18.0	—	50.0	3.0	70.0	5.5	14.0	30.0	Allen Bradley Y-2006, Y-2012 Parker J070/NO70/HDY70
F071-HD185	10.0	—	60.0	3.0	75.0	5.5	11.0	23.0	Allen Bradley MPL210/220/230 Kollmorgen B102/BH-122
F072-HD185	10.0	—	60.0	3.0	75.0	5.5	14.0	30.0	Kollmorgen B104/B106, M-103/105/107, AKM3X-AN, BH-124/126
F081-HD185	15.0	0.5	70.0	3.5	90.0	6.6	14.0	30.0	Yaskawa SGMPH-02XXX, SGMPH-04XXX, SGMP-02, SGMP-04
F082-HD185	15.0	0.5	70.0	3.5	90.0	6.6	16.0	30.0-40.0	Yaskawa SGMAH-08 SGM-08 Allen Bradley Y-3023
F083-HD185	20.0	0.5	70.0	3.5	90.0	5.5	14.0	30.0	Allen Bradley LD-3009
F101-HD185	12.0	0.5	50.0	3.5	95.0	6.6	14.0	30.0	Indramat MKD041
F111-HD185	15.0	0.5	80.0	3.5	100.0	6.6	14.0	30.0	Parker JO92X/NO92X
F121-HD185	20.0	8.0	80.0	3.5	100.0	6.6	16.0	30.0-40.0	Parker MPP92X Allen Bradley MPL310/320/330, LD-4012
F122-HD185	25.0	13.0	80.0	3.5	100.0	6.6	19.0	40.0	Kollmorgen AKM4X-AN Mounting Code Parker ES23X
N231-HD185	12.0	—	38.1	3.0	66.675	5.5	6.35	20.0	Allen Bradley N-2302, N-2304 Animatics SM2310D, SM2320D
N232-HD185	12.0	—	38.1	3.0	66.675	5.5	9.525	20.0-31.0	Parker SM23X, BE23X
N233-HD185	12.0	—	38.1	3.0	66.675	4.5	12.7	20.0	Yaskawa SGMAH-0XXN2XX, SGMAH-04XXN2XX NEMA 23 Face
N341-HD185	20.0	0.5	73.03	3.0	98.425	5.5	12.5	37.0	Parker HV/LV34
N342-HD185	15.0	0.5	73.03	3.0	98.425	5.5	12.7	30.0	Parker BE34

HD Series XY Adapter Dimensions

Dimensions (mm)

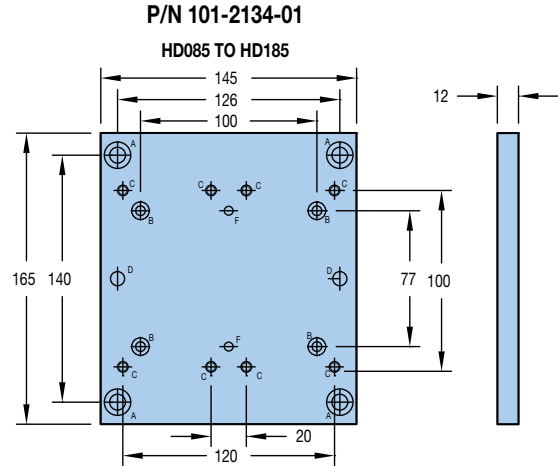
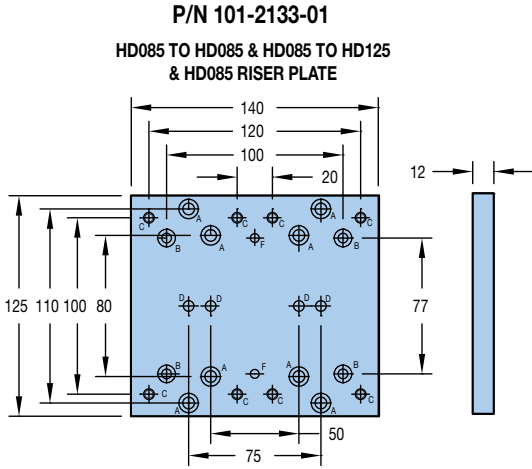

Hole	Description - mm in]	Qty
A	Ø 6.6 [0.256] Thru Hole with a counterbored Ø 11.0 [0.433] X 7.0 [0.276] deep hole	8
B	Ø 5.5 [0.217] Thru Hole with a counterbored Ø 10.0 [0.394] X 6.0 [0.236] Far Side	4
C	Drill & Tap Thru M6 X 1	8
D	Ø 6.006 ^{+0.006} / _{-0.000} [0.2365 ^{+0.0002} / _{-0.0000}]	4
F	Ø 5.006 ^{+0.006} / _{-0.000} [0.1971 ^{+0.0002} / _{-0.0000}]	2

Hole	Description - mm in]	Qty
A	Ø 9.0 [0.3541] Thru Hole with a counterbored Ø 15.0 [0.591] X 9.0 [0.354] deep hole	4
B	Ø 5.5 [0.217] Thru Hole with a counterbored Ø 10.0 [0.394] X 6.0 [0.236] Far Side	4
C	Drill & Tap Thru M6 X 1	8
D	Ø 8.006 ^{+0.006} / _{-0.000} [0.3150 ^{+0.0002} / _{-0.0000}]	4
F	Ø 5.006 ^{+0.006} / _{-0.000} [0.1971 ^{+0.0002} / _{-0.0000}]	2

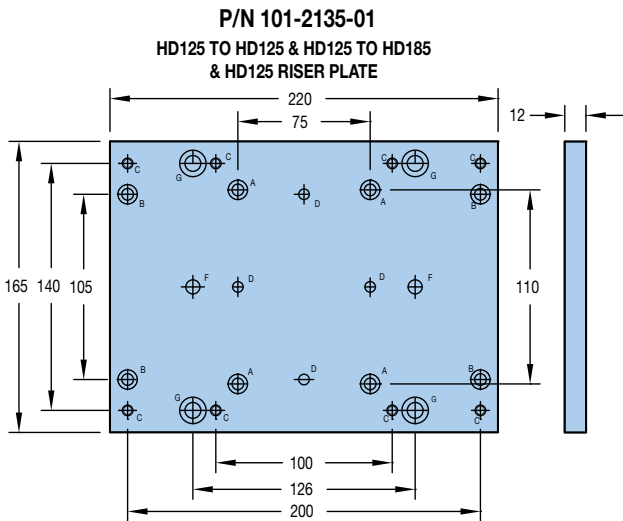

Hole	Description	Qty
A	Ø 6.6 [0.256] Thru Hole with a counterbored Ø 11.0 [0.433] X 7.0 [0.276] deep hole	4
B	Ø 6.6 [0.256] Thru Hole with a counterbored Ø 11.0 [0.433] X 7.0 [0.276] deep hole - Far Side	4
C	Drill & Tap Thru M6 X 1	8
D	Ø 6.006 ^{+0.006} / _{-0.000} [0.2365 ^{+0.0002} / _{-0.0000}]	4
F	Ø 8.006 ^{+0.006} / _{-0.000} [0.3150 ^{+0.0002} / _{-0.0000}]	2
G	Ø 9.0 [0.3541] Thru Hole with a counterbored Ø 15.0 [0.591] X 9.0 [0.354] deep hole	4

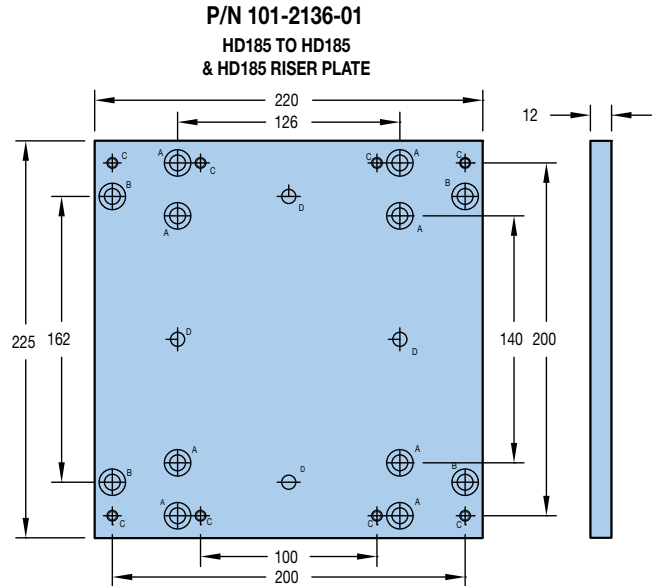

Hole	Description	Qty
A	Ø 9.0 [0.3541] Thru Hole with a counterbored Ø 15.0 [0.591] X 9.0 [0.354] deep hole	8
B	Ø 9.0 [0.3541] Thru Hole with a counterbored Ø 15.0 [0.591] X 9.0 [0.354] deep hole - Far Side	4
C	Drill & Tap Thru M6 X 1	8
D	Ø 8.006 ^{+0.006} / _{-0.000} [0.3150 ^{+0.0002} / _{-0.0000}]	4



HD015 Series Dimensions

Dimensions (mm)

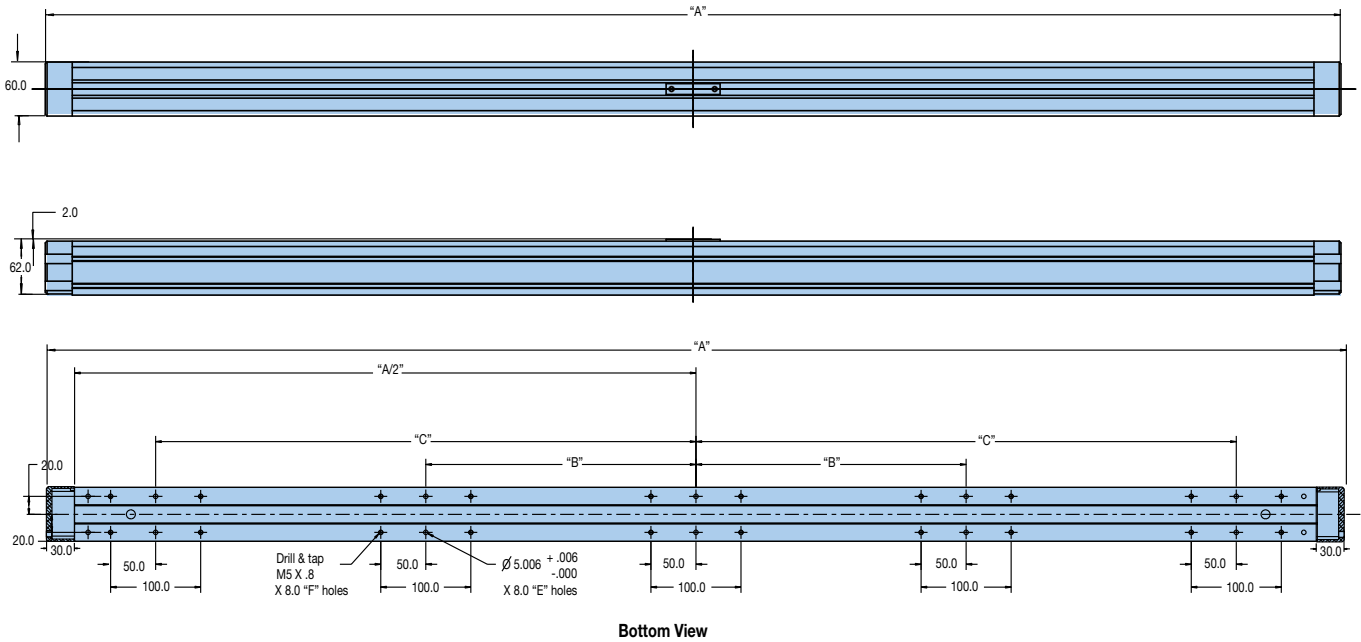

Screw Driven Tables

Model	Travel	Dimensions					
		A	B	C	D	E	F
HD015T01	100	340.0	-	-	5	2	4
HD015T02	200	440.0	-	-	6	2	4
HD015T03	300	540.0	-	150.0	8	6	12
HD015T04	400	640.0	-	200.0	10	6	12
HD015T05	500	740.0	-	250.0	11	6	12
HD015T06	600	840.0	-	300.0	13	6	12
HD015T07	700	940.0	-	345.0	15	6	12
HD015T08	800	1040.0	-	400.0	16	6	12
HD015T09	900	1140.0	-	450.0	18	6	12
HD015T10	1000	1240.0	-	500.0	20	6	12
HD015T11	1100	1340.0	-	550.0	21	6	12
HD015T12	1200	1440.0	300.0	600.0	23	10	20
HD015T13	1300	1540.0	325.0	650.0	25	10	20
HD015T14	1400	1640.0	350.0	700.0	26	10	20
HD015T15	1500	1740.0	375.0	750.0	28	10	20
HD015T16	1600	1840.0	400.0	800.0	30	10	20
HD015T17	1700	1940.0	425.0	850.0	32	10	20
HD015T18	1800	2040.0	450.0	900.0	33	10	20
HD015T19	1900	2140.0	475.0	950.0	35	10	20
HD015T20	2000	2240.0	500.0	100.0	36	10	20

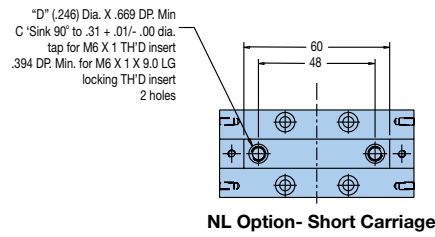
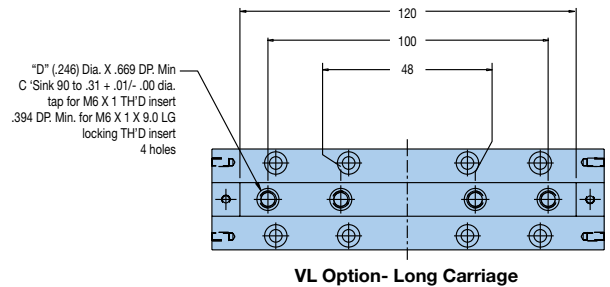

Fill in an order code from each of the numbered fields to create a complete model order code.

① ② ③ ④ ⑤ ⑥ ⑦ ⑧

Order Example: HD085 T08 S D02 M020 LH2 B1 R1

① Series

HD085 85 mm

② Travel*

T01 100 mm
T02 200 mm
T03 300 mm
T04 400 mm
T05 500 mm
T06 600 mm
T07 700 mm
T08 800 mm
T09 900 mm
T10 1000 mm
T11 1100 mm
T12 1200 mm

③ Grade

N Industrial Grade
S Standard Grade

④ Drive

D02* 5 mm lead
D03 10 mm lead
D04 20 mm lead

*Maximum travel for D02 (5 mm lead) = 800 mm (T08).

⑤ Motor Options*

F011 Yaskawa SGMAH-01, SGM-01
 Kollmorgen AKM1X-AN
 Allen Bradley Y-1002, Y-1003
F012 Yaskawa SGMAH-A1XXF4, SGMAH-A3XXF4X,
 SGM-03,SGM-A5
F021 Allen Bradley LD-2003
F031 Parker SMB60/HDY55
 Allen Bradley MPL1510/1520/1530
F041 Kollmorgen AKM2X-AN
 Indramat MKD025
F051 Yaskawa SGMP-01, SGMPH-01-XXXX
F061 Yaskawa SGMAH-02XXF4X, SGMAH-04XXF4X,
 SGM-02, SGM-04
 Allen Bradley Y-2006, Y-2012

F071 Parker J070/NO70/HDY70
 Allen Bradley MPL210/220/230
 Kollmorgen B102/BH-122
F072 Kollmorgen B104/B106, M-103/105/107,
 AKM3X-AN, BH-124/126
M010 Servo with standard encoder (SM232AE-TPSN),
 In-line
M011 Servo with standard encoder (SM232AE-TPSN),
 Parallel "A"
M012 Servo with standard encoder (SM232AE-TPSN),
 Parallel "B"
M020 Servo with standard encoder (SM232AE-TPSB),
 In-line
M021 Servo with standard encoder (SM232AE-TPSB),
 Parallel "A"
M022 Servo with standard encoder (SM232AE-TPSB),
 Parallel "B"
M110 Servo with smart encoder (SM232AQ-TPSN),
 In-line
M111 Servo with smart encoder (SM232AQ-TPSN),
 Parallel "A"
M112 Servo with smart encoder (SM232AQ-TPSN),
 Parallel "B"
M120 Servo with smart encoder & brake
 (SM232AQ-TPSB), In-line
M121 Servo with smart encoder & brake
 (SM232AQ-TPSB), Parallel "A"
M122 Servo with smart encoder & brake
 (SM232AQ-TPSB), Parallel "B"
M100 Stepper (HV232-02-10), In-line only
N231 Parker ES23X
 Allen Bradley N-2302, N-2304
 Animatics SM2310D, SM2320D
N232 Parker SM23X , BE23X
N233 Yaskawa SGMAH-0XXN2XX,
 SGMAH-04XXN2XX NEMA 23 Face
N341 Parker HV/LV34xx (motor sits above and below
 table)

*See Addendum page 100A for additional new "A" or "B" parallel motor codes.

⑥ Home/Limit Switch*

LH1 No sensors
LH2 NPN standard (NC limits, NO home)
LH3 PNP standard (NC limits, NO home)
LH4 PNP standard (NO limits, NO home)

*Includes 5 meter extension cables

⑦ Brake*

B1 No brake

*See motor options

⑧ Environmental Protection





Fill in an order code from each of the numbered fields to create a complete model order code.

① ② ③ ④ ⑤ ⑥ ⑦ ⑧

Order Example: HD125 T04 S D02 M030 LH2 B1 R1

① Series

HD125 125 mm

② Travel*

T02 200 mm
T03 300 mm
T04 400 mm
T05 500 mm
T06 600 mm
T08 800 mm
T10 1000 mm
T12 1200 mm
T14 1400 mm
T15 1500 mm

*Maximum travel for D02 (5 mm lead) = 800 mm (T08).
 Maximum travel for D03 (10 mm lead) = 1000 mm (T10)

③ Grade

N Industrial Grade
S Standard Grade

④ Drive

D02* 5 mm lead
D03 10 mm lead
D04 20 mm lead
D07** 40 mm lead

*D02 only with M01, M11 and M100 motors.
 **D07 option will lose 50 mm of travel below 1100 mm stroke units.

⑤ Motor Options*

F021 Allen Bradley LD-2003
F031 Parker SMB60/HDY55
 Allen Bradley MPL1510/1520/1530
F041 Kollmorgen AKM2X-AN
 Indramat MKD025
F061 Yaskawa SGMAH-02XXF4X, SGMAH-04XXF4X,
 SGM-02, SGM-04
 Allen Bradley Y-2006, Y-2012
F062 Yaskawa SGMAH-02XXF4X, SGMAH-04XXF4X,
 SGM-02, SGM-04
 Allen Bradley Y-2006, Y-2012
F071 Parker J070/NO70/HDY70
 Allen Bradley MPL210/220/230
 Kollmorgen B102/BH-122
F072 Kollmorgen B104/B106, M-103/105/107,
 AKM3X-AN, BH-124/126
F081 Yaskawa SGMPH-02XXX,
 SGMPH-04XXX, SGMP-02, SGMP-04
F082 Yaskawa SGMAH-08 SGM-08
 Allen Bradley Y-3023
F091 Allen Bradley LD-3009
F101 Indramat MKD041
F111 Parker JO92X/NO92X

F121 Parker MPP92X
 Allen Bradley MPL310/320/330, LD-4012
F122 Kollmorgen AKM4X-AN Mounting Code
M010 Servo with standard encoder (SM232AE-TPSN),
 In-line
M011 Servo with standard encoder (SM232AE-TPSN),
 Parallel "A"
M012 Servo with standard encoder (SM232AE-TPSN),
 Parallel "B"
M030 Servo with standard encoder (SM233AE-TPSN),
 In-line
M031 Servo with standard encoder (SM233AE-TPSN),
 Parallel "A"
M032 Servo with standard encoder (SM233AE-TPSN),
 Parallel "B"
M040 Servo with standard encoder (CMP0921B1E)
M110 Servo with smart encoder (SM232AQ-TPSN),
 In-line
M111 Servo with smart encoder (SM232AQ-TPSN),
 Parallel "A"
M112 Servo with smart encoder (SM232AQ-TPSN),
 Parallel "B"
M130 Servo with smart encoder (SM233AQ-TPSN),
 In-line
M131 Servo with smart encoder (SM233AQ-TPSN),
 Parallel "A"
M132 Servo with smart encoder (SM233AQ-TPSN),
 Parallel "B"
M140 Servo with smart encoder (CMP0921B3E)
M100 Stepper (HV232-02-10)
N231 Parker ES23X
 Allen Bradley N-2302, N-2304
 Animatics SM2310D, SM2320D
N232 Parker SM23X, BE23X
N233 Yaskawa SGMAH-0XXN2XX,
 SGMAH-04XXN2XX NEMA 23 Face
N341 Parker HV/LV34
N342 Parker BE34

*See Addendum page 102A for additional new "A" or "B" parallel motor codes.

⑥ Home/Limit Switch*

LH1 No sensors
LH2 NPN standard (NC limits, NO home)
LH3 PNP standard (NC limits, NO home)
LH4 PNP standard (NO limits, NO home)

*Includes 5 meter extension cables

⑦ Brake*

B1 No brake
B2 Brake

⑧ Environmental Protection

R1 IP30, Maintenance free

Screw Driven
Tables



Fill in an order code from each of the numbered fields to create a complete model order code.

① ② ③ ④ ⑤ ⑥ ⑦ ⑧

Order Example: HD185 T05 S D02 M030 LH2 B1 R1

① Series

HD185 185 mm

② Travel*

T03 300 mm
T04 400 mm
T05 500 mm
T06 600 mm
T08 800 mm
T10 1000 mm
T12 1200 mm
T14 1400 mm
T16 1600 mm
T18 1800 mm
T20 2000 mm

③ Grade

N Industrial Grade
S Standard Grade

④ Drive

D02** 5 mm lead
D03 10 mm lead
D04 20 mm lead
D07 40 mm lead

*Maximum travel for D02 (5 mm lead) = 800 mm (T08).
 Maximum travel for D03 (10 mm lead) = 1000 mm (T10)
 **D02 only with M01 and M11 motors.

⑤ Motor Options*

F021 Allen Bradley LD-2003
F031 Parker SMB60/HDY55
 Allen Bradley MPL1510/1520/1530
F041 Kollmorgen AKM2X-AN
 Indramat MKD025
F061 Yaskawa SGMAH-02XXF4X, SGMAH-04XXF4X,
 SGM-02, SGM-04
 Allen Bradley Y-2006, Y-2012
F062 Yaskawa SGMAH-02XXF4X, SGMAH-04XXF4X,
 SGM-02, SGM-04
 Allen Bradley Y-2006, Y-2012
F071 Parker J070/NO70/HDY70
 Allen Bradley MPL210/220/230
 Kollmorgen B102/BH-122
F072 Kollmorgen B104/B106, M-103/105/107,
 AKM3X-AN, BH-124/126
F081 Yaskawa SGMPH-02XXX,
 SGMPH-04XXX, SGMP-02, SGMP-04
F082 Yaskawa SGMAH-08 SGM-08
 Allen Bradley Y-3023
F083 Allen Bradley LD-3009
F101 Indramat MKD041
F111 Parker JO92X/NO92X

F121 Parker MPP92X
 Allen Bradley MPL310/320/330, LD-4012
F122 Kollmorgen AKM4X-AN Mounting Code
M010 Servo with standard encoder (SM232AE-TPSN), In-line
M011 Servo with standard encoder (SM232AE-TPSN),
 Parallel "A"
M012 Servo with standard encoder (SM232AE-TPSN),
 Parallel "B"
M030 Servo with standard encoder (SM233AE-TPSN), In-line
M031 Servo with standard encoder (SM233AE-TPSN),
 Parallel "A"
M032 Servo with standard encoder (SM233AE-TPSN),
 Parallel "B"
M040 Servo with standard encoder (CMP0921B1E), In-line
M041 Servo with standard encoder (CMP0921B1E),
 Parallel "A"
M042 Servo with standard encoder (CMP0921B1E),
 Parallel "B"
M110 Servo with smart encoder (SM232AQ-TPSN), In-line
M111 Servo with smart encoder (SM232AQ-TPSN),
 Parallel "A"
M112 Servo with smart encoder (SM232AQ-TPSN),
 Parallel "B"
M130 Servo with smart encoder (SM233AQ-TPSN), In-line
M131 Servo with smart encoder (SM233AQ-TPSN),
 Parallel "A"
M132 Servo with smart encoder (SM233AQ-TPSN),
 Parallel "B"
M140 Servo (CMP0921B3E), In-line
M141 Servo (CMP0921B3E), Parallel "A"
M142 Servo (CMP0921B3E), Parallel "B"
N231 Parker ES23X
 Allen Bradley N-2302, N-2304
 Animatics SM2310D, SM2320D
N232 Parker SM23X , BE23X
N233 Yaskawa SGMAH-0XXN2XX,
 SGMAH-04XXN2XX NEMA 23 Face
N341 Parker HV/LV34
N342 Parker BE34

*See Addendum page 104A for additional new "A" or "B" parallel motor codes.

⑥ Home/Limit Switch*

LH1 No sensors
LH2 NPN standard (NC limits, NO home)
LH3 PNP standard (NC limits, NO home)
LH4 PNP standard (NO limits, NO home)

*Includes 5 meter extension cables

⑦ Brake*

B1 No brake
B2 Brake

⑧ Environmental Protection

R1 IP30, Maintenance free





Fill in an order code from each of the numbered fields to create a complete model order code.

① ② ③ ④

Order Example: HD015 T04 NL R1

① **Series**

HD015 15 mm

② **Travel***

T03 300 mm
T04 400 mm
T05 500 mm
T06 600 mm
T08 800 mm
T10 1000 mm
T12 1200 mm
T14 1400 mm
T16 1600 mm
T18 1800 mm
T20 2000 mm

③ **Carriage Option**

NL Single bearing truck
VL Double bearing truck

④ **Environmental Protection**

R1 IP30, Maintenance free

Ultra Series Precision Stages

When to Use:

- High-precision sub micron
- Precise repeatability
- Open or closed frame
- Thermal compensation
- Smooth motion

Applications:

- Electronics
- Semiconductor
- Automation
- Medical
- Flat panel

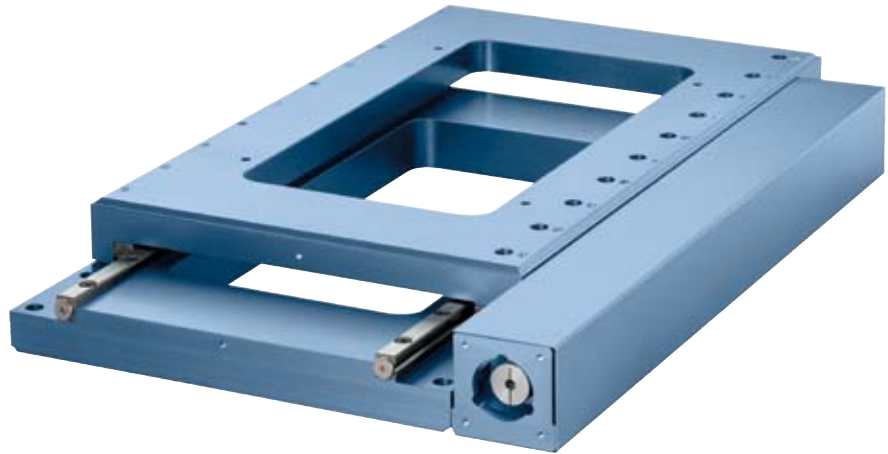

Linear Motor Driven or Screw-Driven Styles

Linear Motor Ultra Stages can achieve sub-micron accuracy with position repeatability of +1 encoder count. Featuring Parker's patented AutoFlex Preload, Linear Motor Ultra Stages provide exceptional smoothness of motion for constant velocity requirements in scanning applications. The AutoFlex preload provides a unique thermal compensation method, eliminating any effects of expansion/ contraction on bearing performance. The brushless linear motor is mounted inverted, with the ironless coil attached to the stationary base, eliminating moving wires.

Traditional Ultra Stages are provided with either a ballscrew or lead screw mounted alongside the stage. This stage configuration allows easy mounting of any step or servo motor with a flexible coupling. The ballscrew version provides high-speed and high force for dynamic move-and-settle applications. The lead screw version provides exceptional smoothness for slow-speed scanning. Both the lead screw and ballscrew models are available with linear encoders, providing high positional accuracy and repeatability.

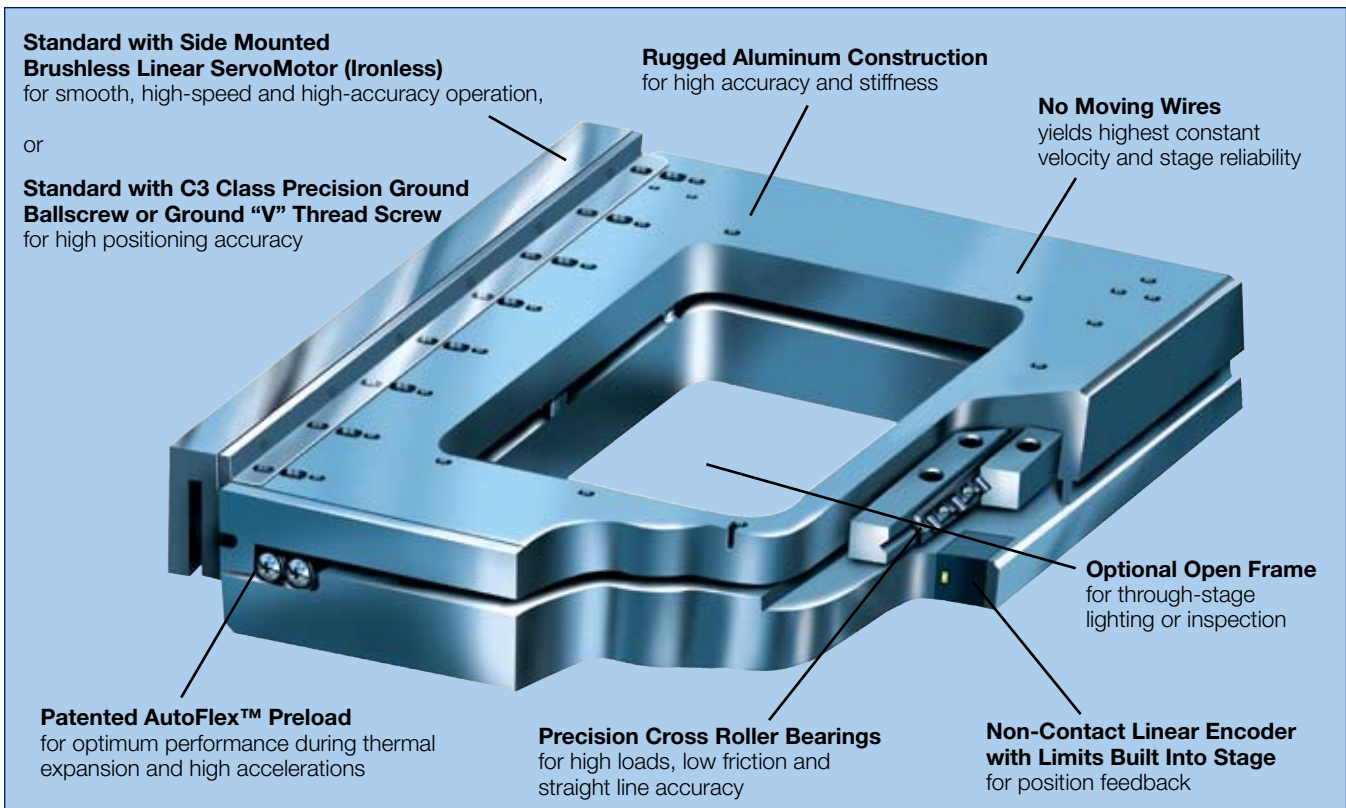



Linear Motor Driven Ultra Stages

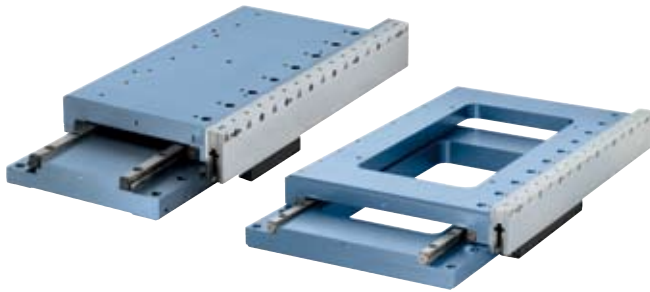

Linear Motor Ultra Stages utilize a non-contact optical linear encoder, integrated directly into the stage footprint. The encoder tape scale is mounted upside-down and referenced directly off the bearing surface, eliminating any Abbe error and protecting it from any debris. The encoder read head is mounted inside the stationary base, eliminating moving wires.

- Sub-micron accuracy
- 0.5 micron repeatability
- Travels from 100 mm to 500 mm
- Patented AutoFlex™ Preload
- Built-in encoder and limits
- Optional open frame construction

U200 Linear Motor Driven

- Closed frame design
- 200 mm wide
- Maximum travel 400 mm
- Maximum load capacity 1,859 kg
- Maximum velocity to 1,500 mm/sec

U300 Linear Motor Driven

- Available in closed-and open-frame design
- 300 mm wide
- Maximum travel 500 mm
- Maximum load capacity 2,187 kg
- Maximum velocity to 1,500 mm/sec

U400 Linear Motor Driven

- Available in closed and open frame design
- 400 mm wide
- Maximum travel 500 mm
- Maximum load capacity 2,187 kg
- Maximum velocity to 1,500 mm/sec

U600 Linear Motor Driven

- Available in open frame design
- 600 mm wide
- Maximum travel 500 mm
- Maximum load capacity 2,187 kg
- Maximum velocity to 1,500 mm/sec

Screw-Driven Ultra Stages

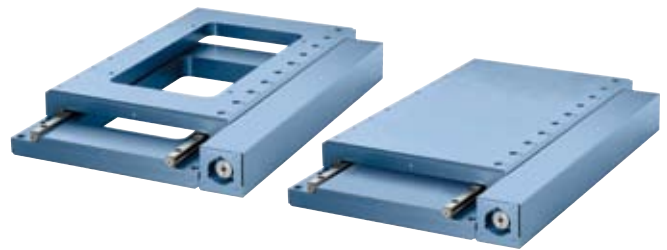

Screw-driven Ultra Stages are ideal for easy mounting to any servo or step motor. For increasing positional accuracy, optional linear encoders are offered.

- Variety of ballscrew and lead screw pitches
- Travels from 100 to 500 mm
- 2 micron repeatability
- Optional linear encoder for direct position feedback
- Optional open frame construction
- Available in closed and open frame design

U200 Screw-Driven

- Available in closed frame design
- 200 mm wide
- Maximum travel 400 mm
- Maximum load capacity 1,859 kg
- NEMA 23 or 60 mm BM Servo motor mounting

U300 Screw-Driven

- Available in closed and open frame design
- 300 mm wide
- Maximum travel 500 mm
- Maximum load capacity 2,187 kg
- NEMA 23 or 60 mm BM Servo motor mounting

U400 Screw-Driven

- Available in closed and open frame design
- 400 mm wide
- Maximum travel 500 mm
- Maximum load capacity 2,187 kg
- NEMA 23 or 60 mm BM Servo motor mounting

U600 Screw-Driven

- Available in open frame design
- 600 mm wide
- Maximum travel 500 mm
- Maximum load capacity 2,187 kg
- NEMA 23 or 60 mm BM Servo motor mounting

Ultra Series Linear Motor Driven Specifications

Performance and Accuracy Specifications

Model Number	Travel Range		Maximum Velocity ⁽¹⁾		Maximum Acceleration ⁽²⁾
	(mm)	(in.)	(mm/sec.)	(in./sec.)	(g)
U200	100 to 400	3.94 to 15.75	1,500	59.1	2
U300	200 to 500	7.87 to 19.69	1,500	59.1	2
U400	300 to 500	11.81 to 19.69	1,500	59.1	2
U600	500	19.69	1,500	59.1	2

Model Number	Straightness/Flatness (microns/25 mm)	Pitch & Yaw (arc-sec/25 mm)	Accuracy ⁽³⁾ (microns/25 mm)	Repeatability ⁽³⁾
U200	±1.25	±2.0	±2	± 0.5
U300	±1.25	±2.0	±2	± 0.5
U400	±1.25	±3.0	±2	± 0.5
U600	±1.25	±3.0	±2	± 0.5

Linear Motor Specifications

All Linear Motor Ultra Series come with a brushless, ironless DC linear servomotor. The standard motors provided yield performance based on the moving mass and the customer load. For additional motor sizes to increase stage performance, please contact the factory.

Specification	Symbol	Unit	Motors for U200-100, U200-200, and U200-300	Motors for U200-400, and All U300 Series	Motors for All U400 and All U600
Peak Force	F _p	N lb	120 27.0	240 54.0	400 90
Continuous Force	F _c	N lb	38 9	76 17	122 28
Motor Constant	K _m	N/√W lb/√W	4.7 1.05	6.6 1.48	9.5 2.14
Max Continuous Dissipation	P _c	W	65	131	167
Peak Current	I _p	amps RMS	7.1	7.1	7.0
Continuous Current	I _c	amps RMS	2.3	2.3	2.1
Resistance	R _{L-L}	ohms	6.1	12.2	17.2
Inductance	L _{L-L}	mH	1.3	2.6	6.0
Back EMF Constant	K _{EL-L}	Vpeak/mm/sec Vpeak/in/sec	13.7 0.35	27.5 0.70	46.5 1.18
Force Constant	K _f	-mps lb/Arms	16.8 3.8	33.7 7.6	57 12.8

⁽¹⁾ Maximum velocity is based on motor size and encoder resolution.

⁽²⁾ Maximum acceleration is load and motor size dependent. Actual acceleration may vary.

⁽³⁾ Accuracy is based on a stage mounted to a flat granite surface and measured at 25mm above the center of the stage. Varies based on encoder length. Repeatability is based on encoder resolution selected and above specification is for 0.1μ resolution.

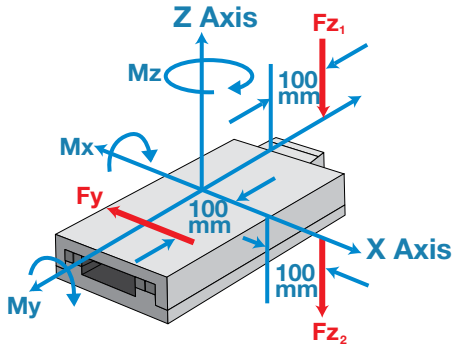

Fz₁ is the load applied in the Z Axis direction, 100 mm off end, causing Mx rotation around the X Axis.

Fz₂ is the load applied in the Z Axis direction, 100 mm off side, causing My rotation around the Y Axis.

Fy is the load applied around the Z Axis at a 100 mm radius from the center, causing Mz rotation around the Z Axis.

Moment Loading ⁽³⁾

Model Number	F (Mx) (Load applied at 100 mm off end)		F (My) (Load applied at 100 mm of side)		F (Mz) (Load applied at 100 mm off center)	
	(kg)	(lb)	(kg)	(lb)	(kg)	(lb)
U200-100	101	222.67	231	509.27	51	112.44
U200-200	108	238.10	313	690.05	54	119.05
U200-300	112	246.92	394	868.62	56	123.46
U200-400	115	253.53	476	1049.40	58	127.87
U300-200	108	238.10	398	877.44	54	119.05
U300-300	112	246.92	502	1106.72	56	123.46
U300-400	115	253.53	606	1336.00	58	127.87
U300-500	117	257.94	710	1565.28	59	130.07
U400-300	112	246.92	564	1243.41	56	123.46
U400-400	115	253.53	681	1501.35	58	127.87
U400-500	117	257.94	798	1759.29	59	130.07
U600-500	117	257.94	785	1730.63	59	130.07

Linear Encoder Specifications

All Linear Motor Ultra Series are provided with a non-contact, optical linear encoder. Each encoder has two (2) magnetic travel limits and one (1) optical home reference built in. Available resolutions are: 0.1 micron, 0.5 micron, 1 micron, 5 microns.

Encoder Power Supply	5 VDC + 5%
Operating Temperature	0° C to 55° C 32° F to 131° F
Output Signal ⁽⁴⁾	Square wave differential line driver
Limit Signal	Magnetic, Normally Closed Sourcing
Home Signal	Optical Reference

(3) Maximum and moment loads are based on bearing capacity. Loading will effect acceleration and velocity capability. Specifications are subject to change without notice. Accuracy can be enhanced with mapping.

(4) Optional analog output head is available for use with external multipliers. Tape scale pitch is 20 microns. Please contact factory.

Ultra Series Screw-Driven Specifications

Travel

Model Number	Maximum Range	
	(in.)	(mm)
U200	100 to 400	3.94 to 15.75
U300	200 to 500	7.87 to 19.69
U400	300 to 500	11.81 to 19.69
U600	500	19.69



Velocity and Thrust

Model Number	Velocity				Maximum Thrust			
	Lead Screw		BallscREW		Lead Screw		BallscREW	
	(mm/sec)	(in/sec)	(mm/sec)	(in/sec)	(kgf)	(lbf)	(kgf)	(lbf)
U200	100	3.94	300	11.81	11.3	24.9	90	198.4
U300	100	3.94	300	11.81	11.3	24.9	90	198.4
U400	100	3.94	300	11.81	11.3	24.9	90	198.4
U600	100	3.94	300	11.81	11.3	24.9	90	198.4

Accuracy Specifications

Model Number	Straightness/Flatness		Pitch & Yaw
	(microns/25 mm)	(in/in)	
U200	±1.25	±0.00005	±2.0
U300	±1.25	±0.00005	±2.0
U400	±1.25	±0.00005	±3.0
U600	±1.25	±0.00005	±3.0

Model Number	Accuracy ⁽³⁾		Repeatability ⁽⁴⁾	
	(microns/25 mm)	(in)	(microns)	(in)
U200	±2.5	0.0001	±2.0	0.00008
U300	±2.5	0.0001	±2.0	0.00008
U400	±2.5	0.0001	±2.0	0.00008
U600	±2.5	0.0001	±2.0	0.00008

(1) Based on 0.2 in Ballscrew.

(2) Based on 10 mm Lead Screw.

(3) Accuracy is based on a stage mounted to a flat granite surface and measured at 25 mm above the center of the stage.

(4) Repeatability is based on encoder resolution selected and above specification is for 0.1µ resolution. Lead accuracy of ballscrew (open loop without encoder) is + 6 µm over travel range.

(5) Maximum and moment loads are based on bearing capacity. Loading will affect acceleration and velocity capability. Specifications are subject to change without notice.

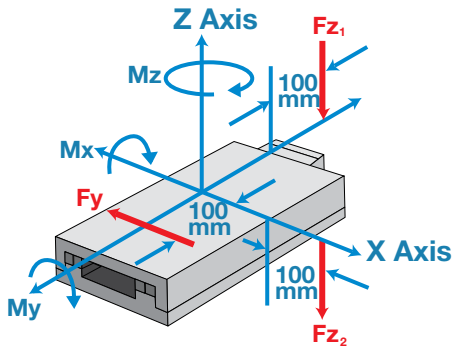

Fz_1 is the load applied in the Z Axis direction, 100 mm off end, causing Mx rotation around the X Axis.

Fz_2 is the load applied in the Z Axis direction, 100 mm off side, causing My rotation around the Y Axis.

Fy is the load applied around the Z Axis at a 100 mm radius from the center, causing Mz rotation around the Z Axis.

Moment Loading ⁽⁵⁾

Model No.	F (Mx) (Load applied at 100 mm off end)		F (My) (Load applied at 100 mm off side)		F (Mz) Load applied at 100 mm off center	
	(kg)	(lb)	(kg)	(lb)	(kg)	(lb)
U200-100	101	222.67	231	509.27	51	112.44
U200-200	108	238.10	313	690.05	54	119.05
U200-300	112	246.92	394	868.62	56	123.46
U200-400	115	253.53	476	1049.40	58	127.87
U300-200	108	238.10	398	877.44	54	119.05
U300-300	112	246.92	502	1106.72	56	123.46
U300-400	115	253.53	606	1336.00	58	127.87
U300-500	117	257.94	710	1565.28	59	130.07
U400-300	112	246.92	564	1243.41	56	123.46
U400-400	115	253.53	681	1501.35	58	127.87
U400-500	117	257.94	798	1759.29	59	130.07
U600-500	117	257.94	785	1730.63	59	130.07

Screw Inertia

Model No.	Lead Screw		Ballscrew		Coupling Inertia		Moving Slide Weight			
	(gm cm sec ²)	(oz in sec ²)	(gm cm sec ²)	(oz in sec ²)	(gm cm sec ²)	(oz in sec ²)	Closed		Open	
							(kg)	(lb)	(kg)	(lb)
U200-100	0.039	0.00054	0.104	0.0015	0.026	0.00035	4.26	9.37	—	—
U200-200	0.060	0.00083	0.157	0.0022	0.026	0.00035	6.16	13.55	—	—
U200-300	0.081	0.00113	0.209	0.0029	0.026	0.00035	8.11	17.84	—	—
U200-400	0.102	0.00142	0.262	0.0036	0.026	0.00035	10.09	22.20	—	—
U300-200	0.060	0.00083	0.157	0.0022	0.026	0.00035	8.4	18.48	4.27	9.39
U300-300	0.081	0.00113	0.209	0.0029	0.026	0.00035	11.11	24.44	5.29	11.63
U300-400	0.102	0.00142	0.261	0.036	0.026	0.00035	13.81	30.38	6.93	15.25
U300-500	0.123	0.00171	0.314	0.0044	0.026	0.00035	16.53	36.36	8.25	18.15
U400-300	0.081	0.0011	0.209	0.0029	0.026	0.00035	14.11	31.04	6.87	15.11
U400-400	0.102	0.0014	0.262	0.0036	0.026	0.00035	17.6	38.72	8.53	18.76
U400-500	0.123	0.0017	0.314	0.0044	0.026	0.00035	21.03	46.27	10.16	22.35
U600-500	0.123	0.0017	0.314	0.0043	0.026	0.00035	—	—	13.99	30.77

U200 Linear Motor Drive Dimensions

Dimensions (mm)

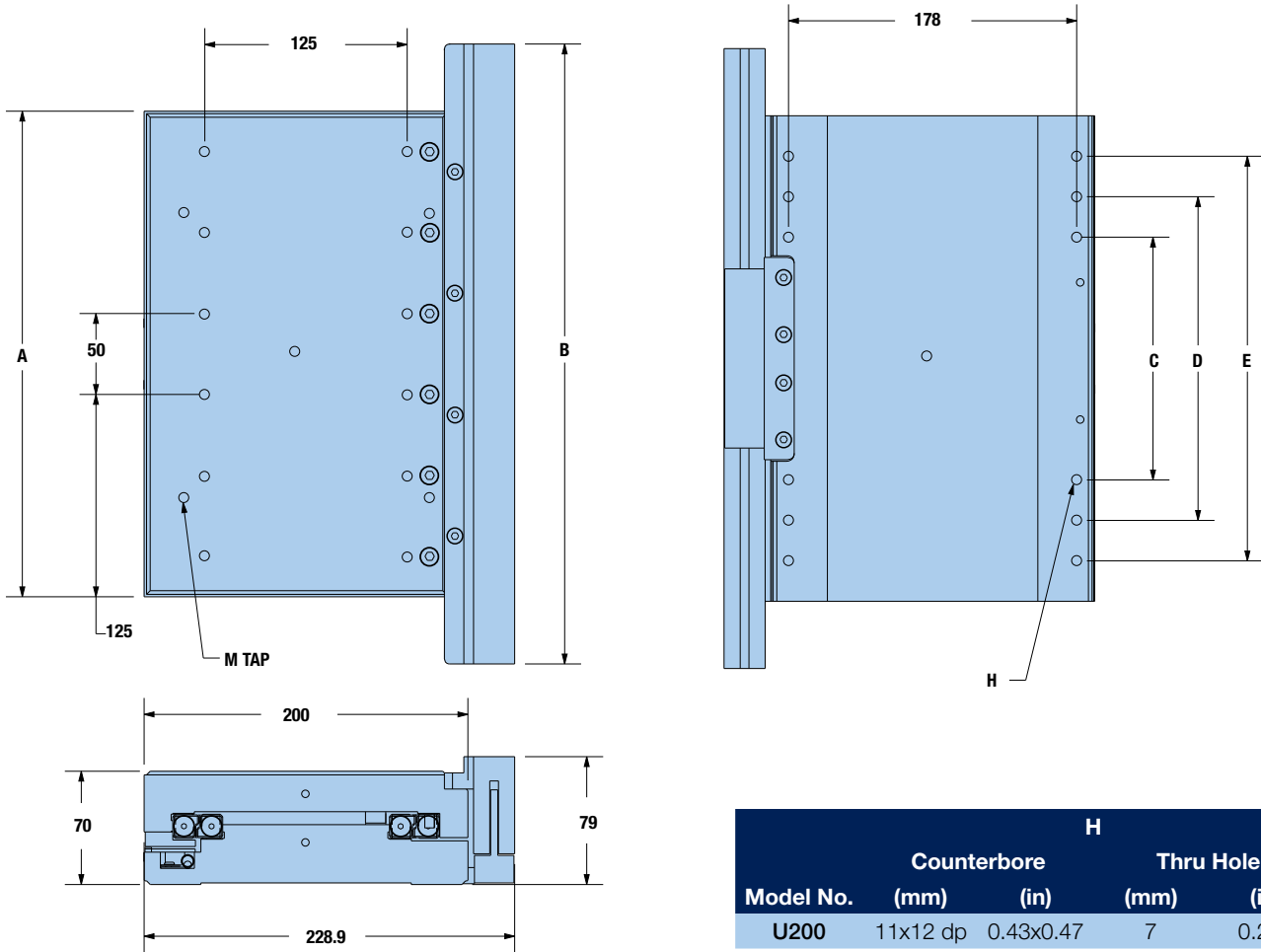

Model No.	Counterbore		Thru Hole	
	(mm)	(in)	(mm)	(in)
U200	11x12 dp	0.43x0.47	7	0.275

Model No.	Travel		A		B		C		D	
	(mm)	(in)	(mm)	(in)	(mm)	(in)	(mm)	(in)	(mm)	(in)
U200-100	100	3.94	200	7.87	256	10.08	150	5.91	—	—
U200-200	200	7.87	300	11.81	384	15.12	150	5.91	—	—
U200-300	300	11.81	400	15.75	448	17.64	150	5.91	—	—
U200-400	400	15.75	500	19.69	640	25.20	150	5.91	300	11.81

Model No.	E		M Tap	Load Capacity		Stage Weight		Moving Slide Weight	
	(mm)	(in)		(kg)	(lb)	(kg)	(lb)	(kg)	(lb)
U200-100	—	—	M6 x 1	875	1,929	11.39	25.11	6.8	14.99
U200-200	275	10.83	M6 x 1	1,203	2,652	16.68	36.77	9.9	21.83
U200-300	375	14.76	M6 x 1	1,531	3,375	21.56	47.53	12.58	27.73
U200-400	475	18.70	M6 x 1	1,859	4,098	27.68	61.02	16.35	36.05



U300 Linear Motor Drive Dimensions

Dimensions (mm)

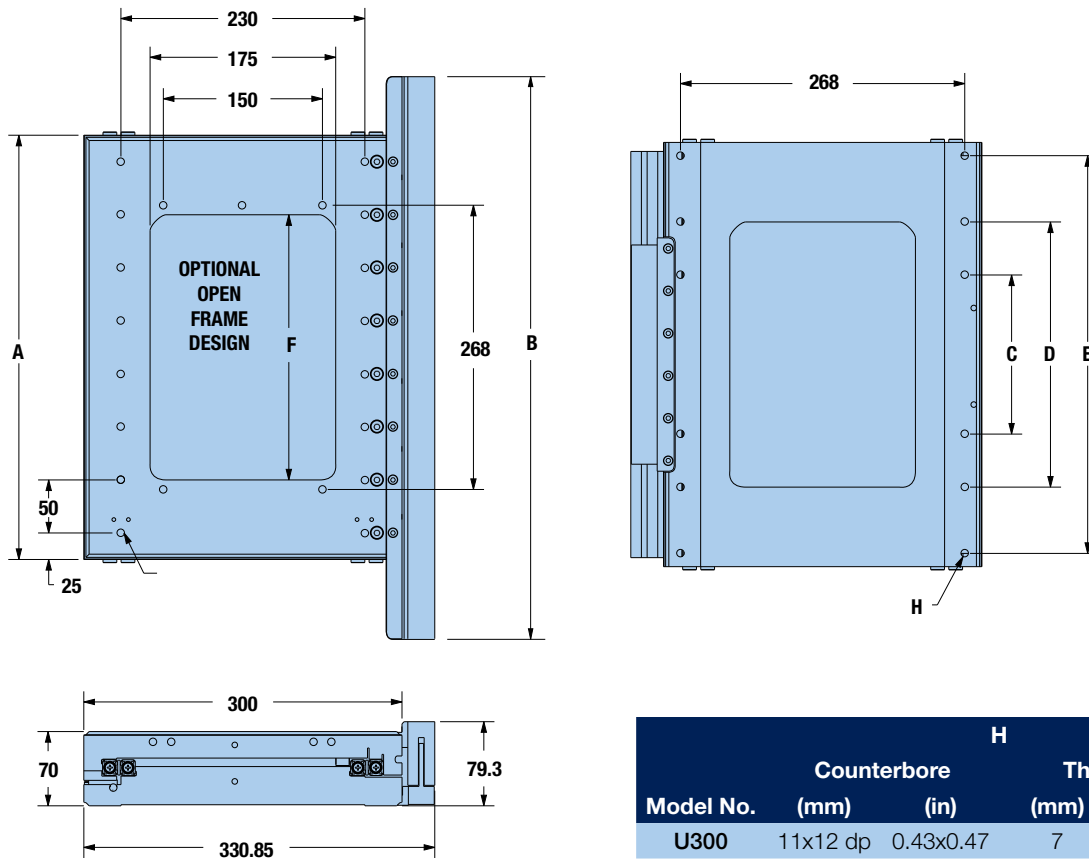

Screw Driven Tables

Model No.	Counterbore		Thru Hole	
	(mm)	(in)	(mm)	(in)
U300	11x12 dp	0.43x0.47	7	0.275

Model No.	Travel		A		B		C		D	
	(mm)	(in)	(mm)	(in)	(mm)	(in)	(mm)	(in)	(mm)	(in)
U300-200	200	7.87	300	11.81	448	17.64	150	5.91	—	—
U300-300	300	11.81	400	15.75	576	22.68	150	5.91	200	7.87
U300-400	400	15.75	500	19.69	640	25.20	200	7.87	350	13.78
U300-500	500	19.69	600	23.62	768	30.24	200	7.87	400	15.75

Model No.	E		F		M Tap	Load Capacity	
	(mm)	(in)	(mm)	(in)		(kg)	(lb)
U300-200	275	10.83	150	5.91	M6 x 1	1,203	2,652
U300-300	375	14.76	250	9.84	M6 x 1	1,531	3,375
U300-400	475	18.70	350	13.78	M6 x 1	1,859	4,098
U300-500	575	22.64	450	17.72	M6 x 1	2,187	4,822

Model No.	Moving Slide Weight				Stage Weight			
	Open		Closed		Open		Closed	
	(kg)	(lb)	(kg)	(lb)	(kg)	(lb)	(kg)	(lb)
U300-200	8.62	19.00	12.75	28.11	13.31	29.34	22.93	50.55
U300-300	11.26	24.82	16.78	36.99	17.37	38.29	30.24	66.67
U300-400	13.19	29.58	20.07	44.25	20.74	45.72	36.79	81.11
U300-500	15.84	34.92	24.12	53.18	24.80	54.67	44.11	97.25



U400 Linear Motor Drive Dimensions

Dimensions (mm)

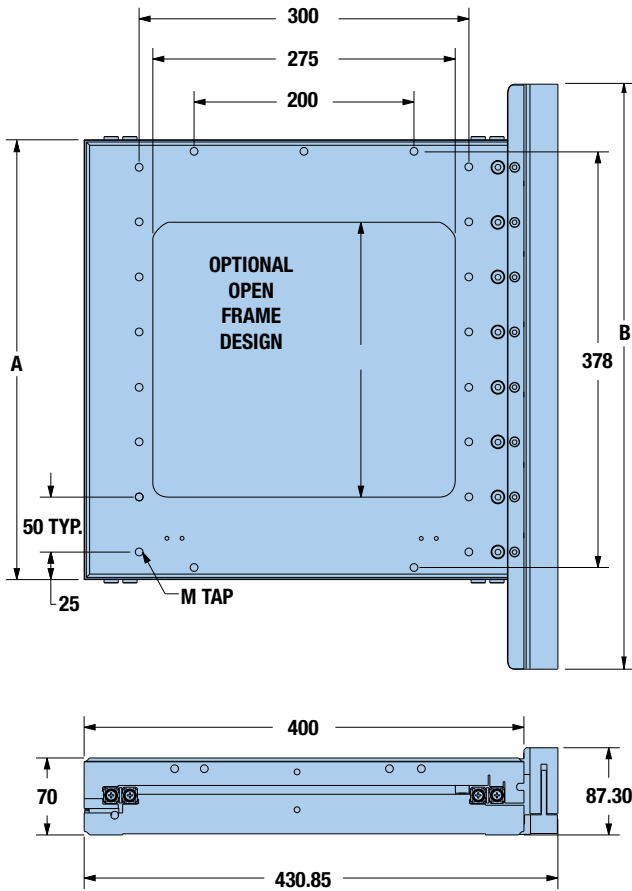

Model No.	Counterbore		Thru Hole	
	(mm)	(in)	(mm)	(in)
U400	11x12 dp	0.43x0.47	7	0.275

Model No.	Travel		A		B		C		D	
	(mm)	(in)	(mm)	(in)	(mm)	(in)	(mm)	(in)	(mm)	(in)
U400-300	300	11.81	400	15.75	576	22.68	200	7.87	—	—
U400-400	400	15.75	500	19.69	640	25.20	200	7.87	350	13.78
U400-500	500	19.69	600	23.62	768	30.24	200	7.87	400	15.75

Model No.	E		F		M Tap	Load Capacity	
	(mm)	(in)	(mm)	(in)		(kg)	(lb)
U400-300	375	14.76	250	9.84	M6 x 1	1,531	3,375
U400-400	475	18.70	350	13.78	M6 x 1	1,859	4,098
U400-500	575	22.64	450	17.72	M6 x 1	2,187	4,821

Model No.	Moving Slide Weight				Stage Weight			
	Open		Closed		Open		Closed	
	(kg)	(lb)	(kg)	(lb)	(kg)	(lb)	(kg)	(lb)
U400-300	12.88	28.40	20.12	44.36	20.76	45.77	38.00	83.77
U400-400	15.31	33.75	33.75	53.75	25.00	55.12	46.60	102.73
U400-500	18.36	40.48	40.48	64.44	30.05	66.25	56.25	124.01



U600 Linear Motor Drive Dimensions

Dimensions (mm)

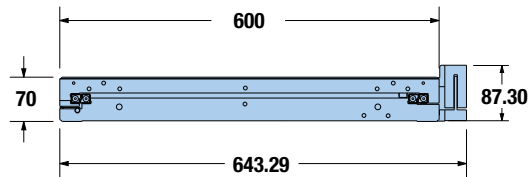
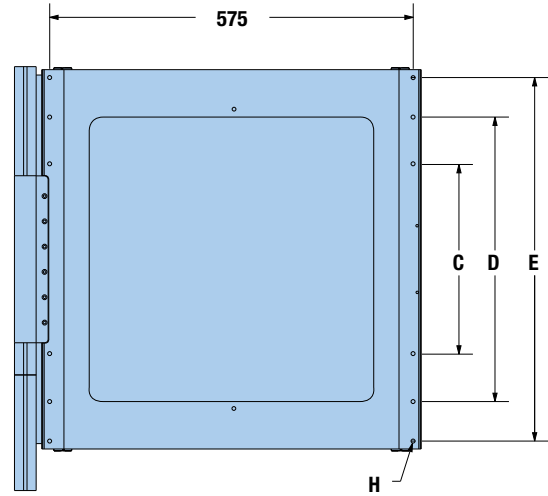
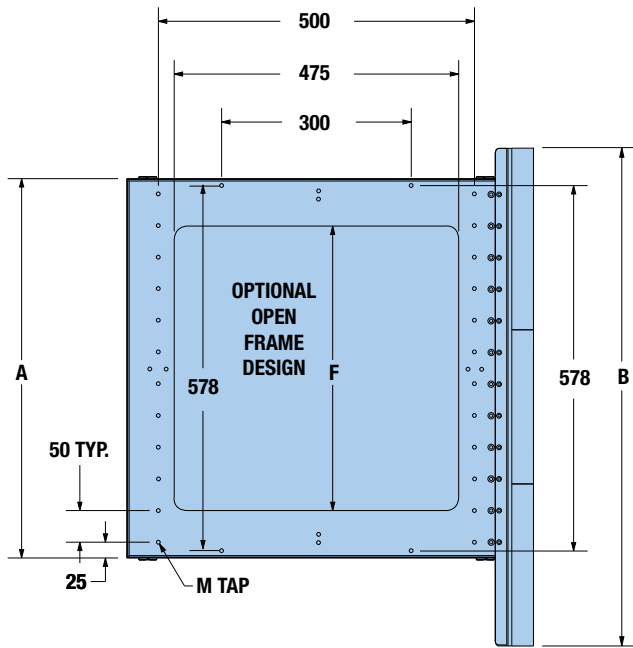

Model No.	Counterbore		Thru Hole	
	(mm)	(in)	(mm)	(in)
U600	11x12 dp	0.43x0.47	7	0.275

Model No.	Travel		A		B		C		D	
	(mm)	(in)	(mm)	(in)	(mm)	(in)	(mm)	(in)	(mm)	(in)
U600-500	500	19.69	600	23.62	768	30.24	300	11.81	450	17.72

Model No.	E		F		M Tap	Load Capacity	
	(mm)	(in)	(mm)	(in)		(kg)	(lb)
U600-500	575	22.64	450	17.72	M6 x 1	2,187	4821

Model No.	Moving Slide Weight		Stage Weight	
	(kg)	(lb)	(kg)	(lb)
U600-500	22.19	48.92	38.63	85.16

Screw Driven Tables

U200 Screw-Driven Drive Dimensions

Dimensions (mm)

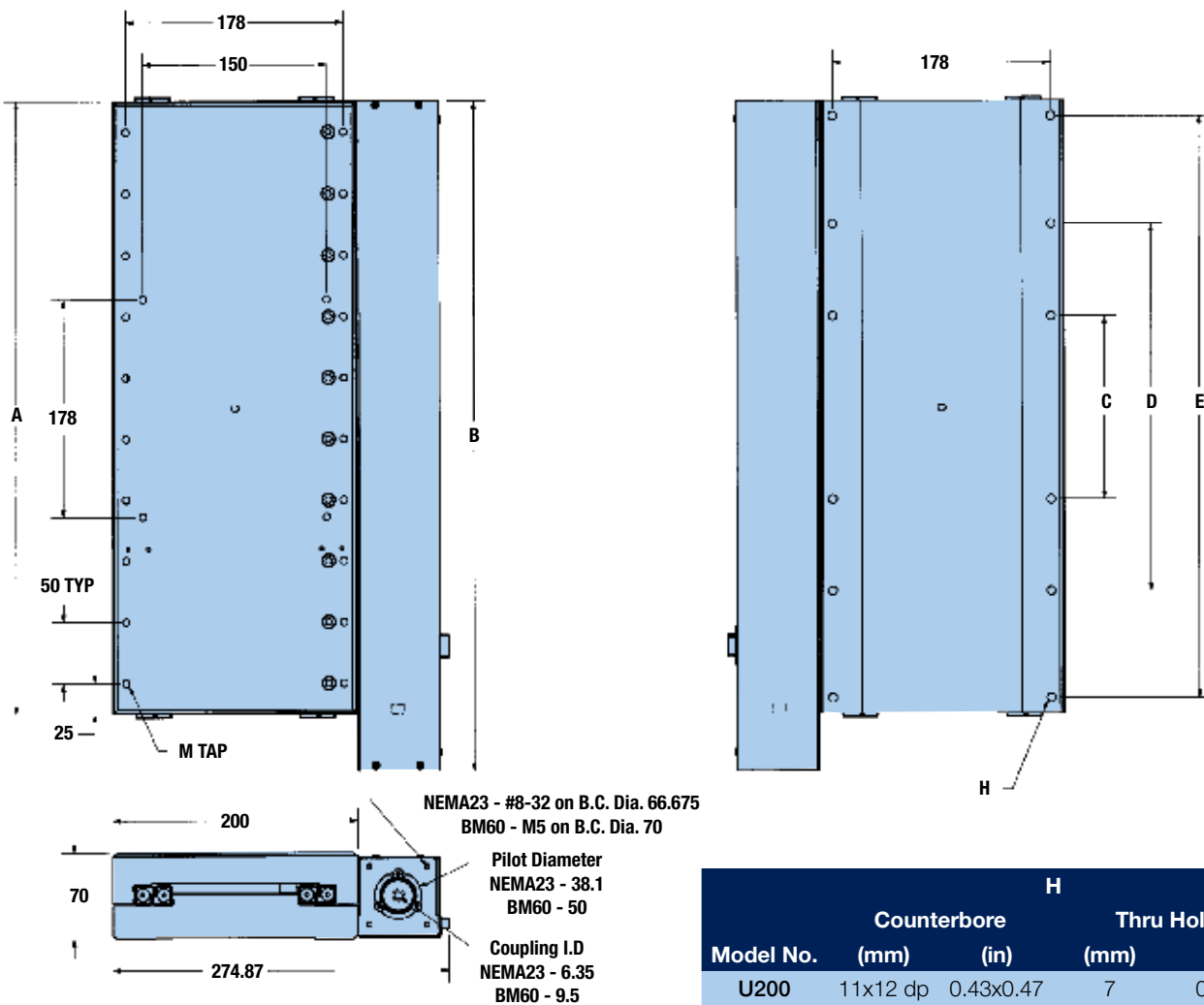

Model No.	Travel		A		B		C		D	
	(mm)	(in)	(mm)	(in)	(mm)	(in)	(mm)	(in)	(mm)	(in)
U200-100	100	3.94	200	7.87	246	9.7	150	5.9	—	—
U200-200	200	7.87	300	12.25	346.5	13.64	150	5.9	—	—
U200-300	300	11.81	400	15.75	446.5	17.59	150	5.9	—	—
U200-400	400	15.75	500	19.69	546.5	21.52	150	5.9	300	12.25

Model No.	E		M Tap	Load Capacity		Stage Weight		Moving Slide Weight	
	(mm)	(in)		(kg)	(lb)	(kg)	(lb)	(kg)	(lb)
U200-100	—	—	M6 x 1	875	1,929	9.48	20.9	4.26	9.39
U200-200	275	10.83	M6 x 1	1,203	2,652	13.72	30.25	6.16	13.58
U200-300	375	14.76	M6 x 1	1,531	3,375	18.02	39.73	8.11	17.88
U200-400	475	18.7	M6 x 1	1,859	4,098	22.35	49.27	10.09	22.24



U300 Screw-Driven Drive Dimensions

Dimensions (mm)

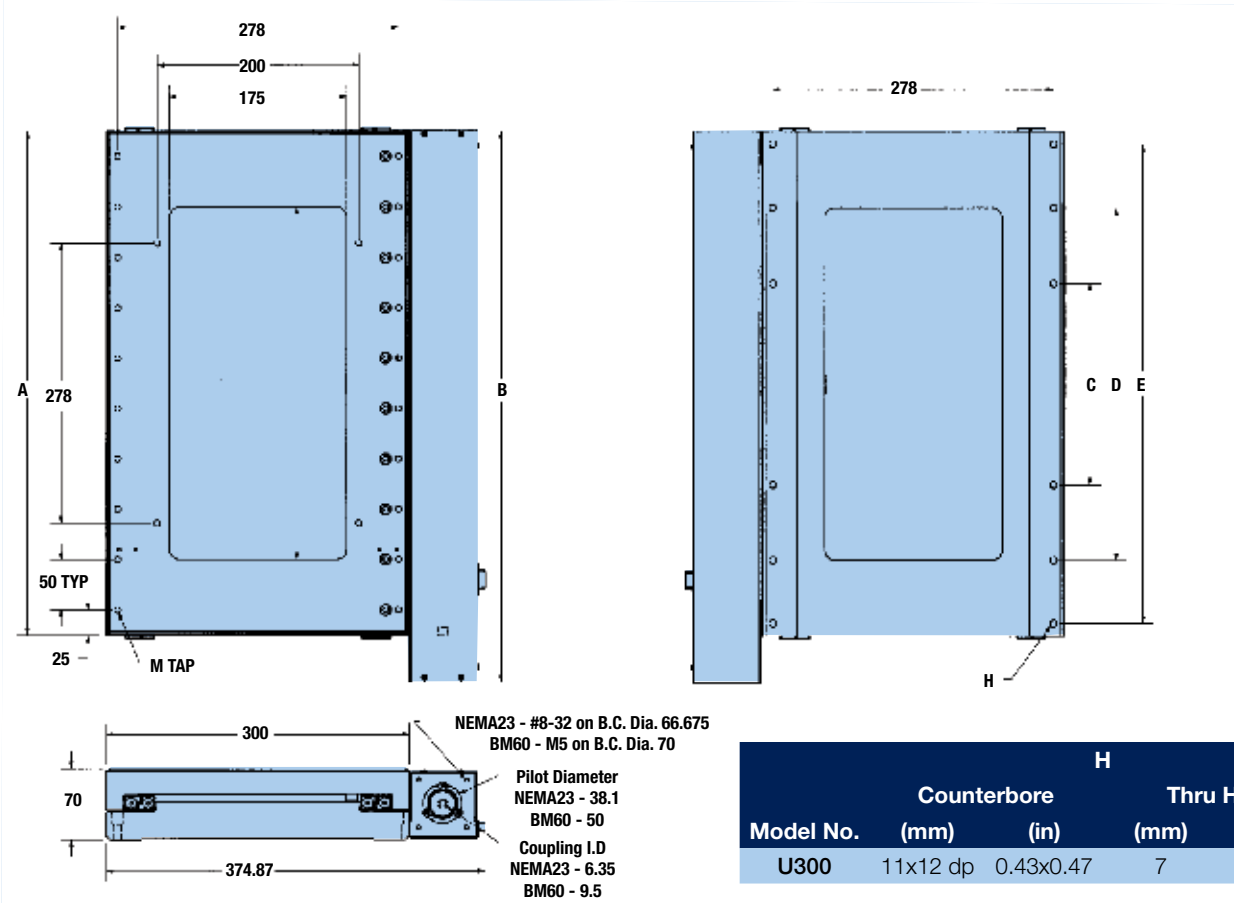

Model No.	Counterbore		Thru Hole	
	(mm)	(in)	(mm)	(in)
U300	11x12 dp	0.43x0.47	7	0.275

Model No.	Travel		A		B		C		D	
	(mm)	(in)	(mm)	(in)	(mm)	(in)	(mm)	(in)	(mm)	(in)
U300-200	200	7.87	300	12.25	346.5	13.6	150	5.9	—	—
U300-300	300	12.25	400	15.75	446.5	17.6	150	5.9	200	7.87
U300-400	400	15.75	500	19.69	546.5	21.5	200	7.9	350	13.78
U300-500	500	19.69	600	23.62	646.5	25.5	200	7.9	400	15.75

Model No.	E		F		M Tap	Load Capacity	
	(mm)	(in)	(mm)	(in)		(kg)	(lb)
U300-200	275	10.83	150	5.9	M6 x 1	1,203	2,652
U300-300	375	14.76	250	9.84	M6 x 1	1,531	3,375
U300-400	475	18.7	350	13.78	M6 x 1	1,859	4,095
U300-500	575	22.64	450	17.72	M6 x 1	2,187	4,821

Model No.	Stage Weight				Moving Slide Weight			
	Open		Closed		Open		Closed	
	(kg)	(lb)	(kg)	(lb)	(kg)	(lb)	(kg)	(lb)
U300-200	9.59	21.1	19.21	42.35	4.27	9.41	8.4	18.5
U300-300	12.48	27.5	25.35	55.89	5.29	11.66	11.11	24.5
U300-400	15.41	33.9	31.46	69.36	6.93	15.28	13.81	30.4
U300-500	18.29	40.3	37.6	82.89	8.25	18.19	16.53	36.4

Screw Driven Tables

U400 Screw-Driven Drive Dimensions

Dimensions (mm)

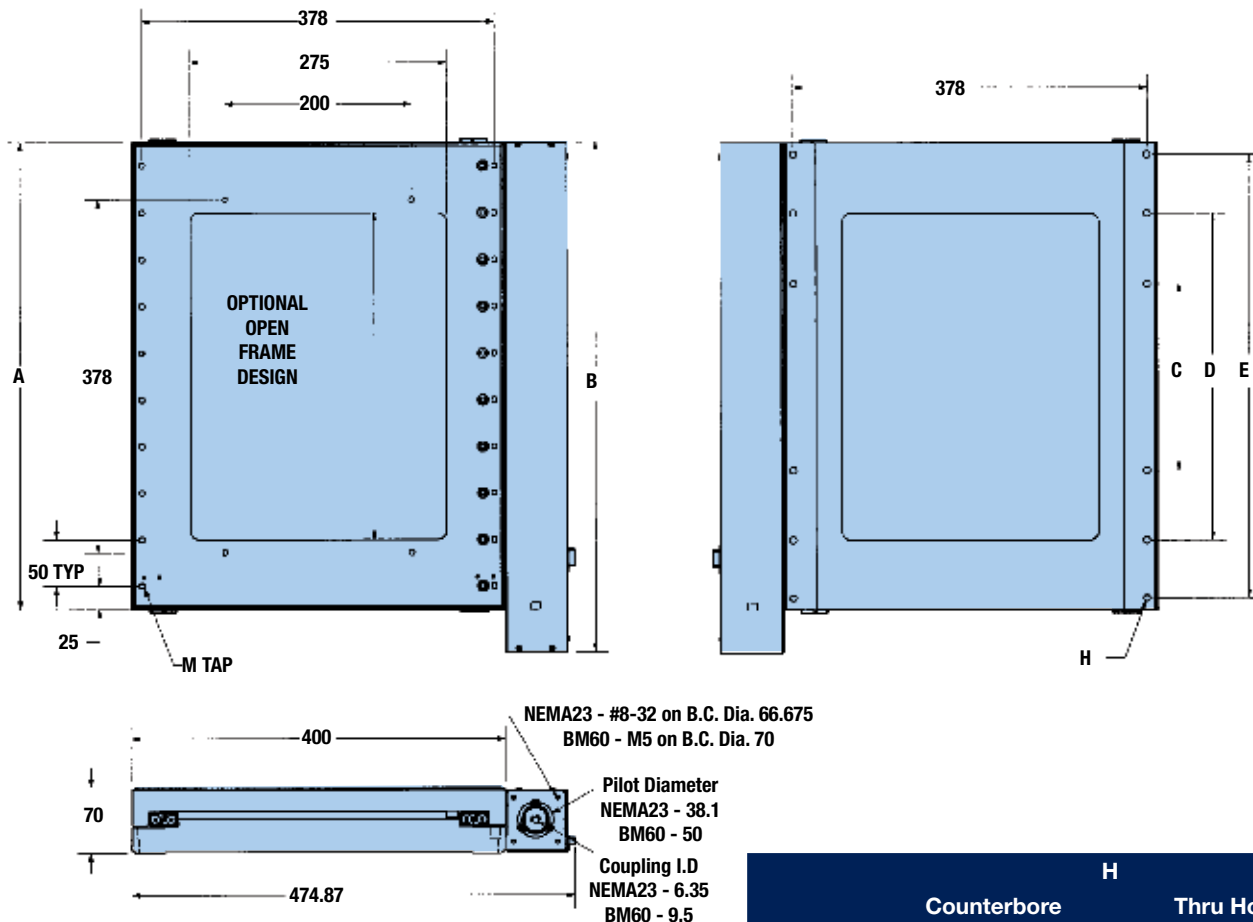

Model No.	Counterbore		Thru Hole	
	(mm)	(in)	(mm)	(in)
U400	11x12 dp	0.43x0.47	7	0.275

Model No.	Travel		A		B		C		D	
	(mm)	(in)	(mm)	(in)	(mm)	(in)	(mm)	(in)	(mm)	(in)
U400-300	300	11.81	400	15.75	446.5	17.58	200	7.87	—	—
U400-400	400	15.75	500	19.69	546.5	21.52	200	7.87	350	13.78
U400-500	500	19.69	600	23.62	646.5	25.45	200	7.87	400	15.75

Model No.	E		F		M	Load Capacity	
	(mm)	(in)	(mm)	(in)		(kg)	(lb)
U400-300	375	14.76	250	9.84	M6 x 1	1,531	3,375
U400-400	475	18.70	350	13.78	M6 x 1	1,859	4,098
U400-500	575	22.64	450	17.72	M6 x 1	2,187	4,822

Model No.	Stage Weight				Moving Slide Weight			
	Open		Closed		Open		Closed	
	(kg)	(lb)	(kg)	(lb)	(kg)	(lb)	(kg)	(lb)
U400-300	15.28	33.69	32.52	71.69	6.87	15.15	14.11	31.11
U400-400	18.90	40.34	40.50	88.29	8.53	18.81	17.60	38.80
U400-500	22.68	50.00	48.88	107.76	10.16	22.40	21.03	46.36



U600 Screw-Driven Drive Dimensions

Dimensions (mm)

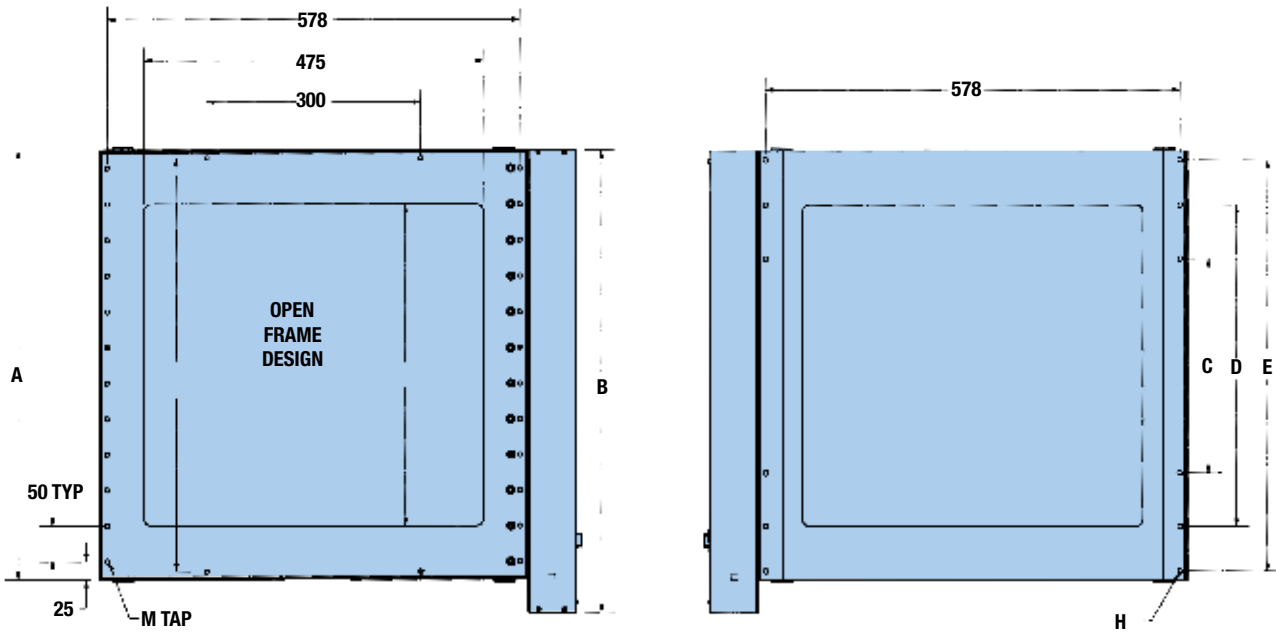

Screw Driven Tables

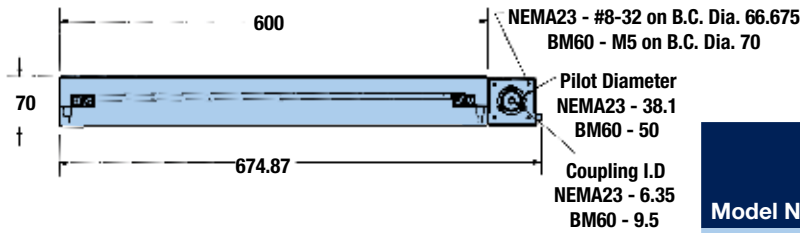

Model No.	Counterbore		Thru Hole	
	(mm)	(in)	(mm)	(in)
U600	11x12 dp	0.43x0.47	7	0.275

Model No.	Travel		A		B		C		D	
	(mm)	(in)	(mm)	(in)	(mm)	(in)	(mm)	(in)	(mm)	(in)
U600-500	500	19.69	600	23.62	646.5	25.45	300	11.81	450	17.72

Model No.	E		F		M Tap	Load Capacity	
	(mm)	(in)	(mm)	(in)		(kg)	(lb)
U600-500	575	22.64	450	17.72	M6 x 1	2,187	4822

Model No.	Moving Slide Weight		Stage Weight	
	(kg)	(lb)	(kg)	(lb)
U600-500	31.41	69.25	13.99	30.84

Suggested Configuration

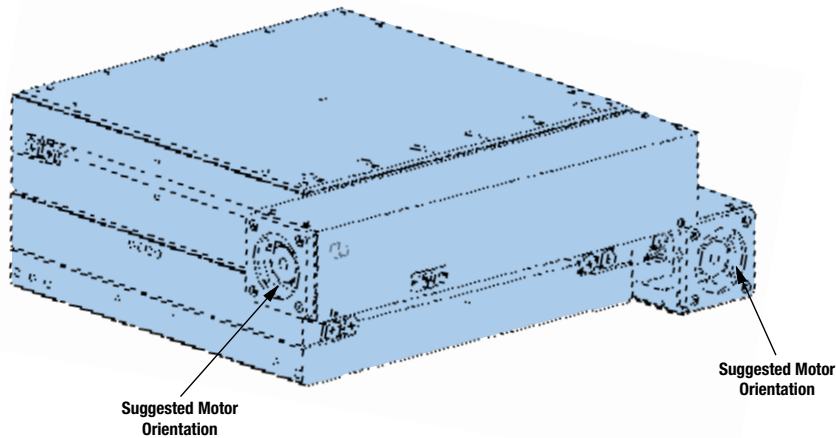

Options

Calibration Option

Parker provides laser-calibrated and / or matched roller options to optimize your stage for the most demanding applications.

P.A.C.T.

Prevents cross roller bearing creep in vertical and/or high-speed applications.

Special Environment Option

Parker can prepare your stage for a variety of environments including:

- Vacuum
- Cleanroom
- Radiation
- Food Grade

Special Lubricants

Dry lubricant suitable for environments that need a dry, permanent lubrication (e.g. vacuum rated applications).



Fill in an order code from each of the numbered fields to create a complete model order code.

① ② ③ ④ ⑤ ⑥ ⑦ ⑧ ⑨

Order Example: U 300 X 3 2 1 3 1 1

① Series

U Ultra Series

② Metric Width of Stage

200 200 mm
300 300 mm
400 400 mm
600 600 mm

③ Frame

	U200	U300	U400	U600
X	Closed	Closed	Closed	Closed
H	—	Open	Open	Open

④ Travel

	U200	U300	U400	U600
1	100 mm	—	—	—
2	200 mm	200 mm	—	—
3	300 mm	300 mm	300 mm	—
4	400 mm	400 mm	400 mm	—
5	—	500 mm	500 mm	500 mm

⑤ Drive Screw

Lead Screw

1 0.1 in lead
2 0.2 in lead
3 1 mm lead

Ballscrew

4 3 mm lead
5 5 mm lead
6 10 mm lead

Linear Motor

7 Linear motor drive

⑥ Limits ⁽¹⁾

1 None
2 End of travel
3 End of travel and home

⑦ Linear Encoder ⁽¹⁾

1 None
2 0.1 μm
3 0.5 μm
4 1.0 μm
5 5.0 μm

(1) End-of-Travel and Home Limits integral to linear encoder will be provided, when a linear encoder is selected.

⑧ Motor Mounting

X Specify motor, make and model for mounting kit

⑨ Roller Configuration/Environment

1 None (standard)
2 PACT
5 Cleanroom (Class 10,000)
6 Cleanroom (Class 10,000) with PACT
9 Vacuum (no finish)

Screw Driven
Tables

100CT & 800CT Cross Roller Tables

Features

- Twice as strong as the same size ball bearing table
- Non-recirculating bearing design for the smoothest linear translation
- Leadscrew drive for smooth motion or ballscrew drive for 100% duty cycle
- Highly repeatable positioning ($\pm 0.00005"$)
- Precision ground top and bottom mounting surfaces

Quality Design and Construction

The 100CT and 800CT linear tables employ a non-recirculating cross roller bearing system to provide smooth linear translation of heavier loads where mechanical disturbance cannot be tolerated. They are offered in two styles – the 100CT and 800CT.

The 100CT is a low profile light duty cross roller table. It is similar in size and shape to the 100BT ball bearing table and utilizes the same pre-loaded leadscrew drive. It is designed to fit those applications whose load requirements exceed the 100BT and whose duty cycle is less than 75%.

The 800CT is a rugged table rated at 100% duty cycle. It has a larger cross roller bearing system and an efficient (90%) ballscrew drive, and should be considered in high to ultra high-end applications that require accurate positioning over a relatively short distance at slow to moderate speeds and accelerations.

Options

Motor Couplings

A wide range of coupling styles and bores are available to match motor requirements. Bellows-style couplings are required for all precision grade tables and have the lowest radial windup, while the aluminum and stainless steel helix couplers offer good windup characteristics and high durability at a lower cost.

Motor Mounts

The motor mount is designed for an industry standard NEMA 23 motor flange with shaft lengths between 0.65 and 0.85 inches.

Limit and Home Switches

All styles can be equipped with either mechanical reed switch or optical sensor type limit and home switch assemblies. The limit switches provide a signal when the table is approaching its end of travel which is used to command the motor to stop. The Home sensor provides a fixed reference point to which the table can always return.

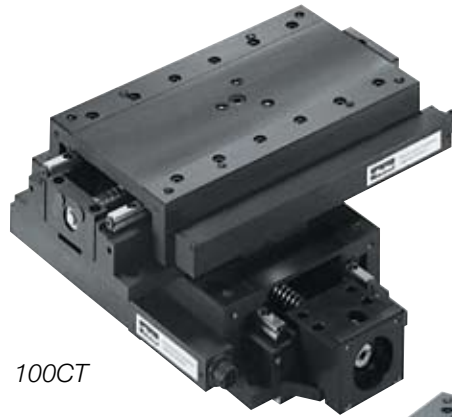

100CT



800CT

Linear Encoders

This option mounts to the side of the table and is used to give direct positional feedback of the carriage. English resolution of 0.0001 inch and metric resolution of 0.001 mm are available.

Z-Brackets

Brackets for vertical mounting of these units are offered as a standard accessory.

Note: Refer to www.parkermotion.com or contact a Parker applications engineer for additional detailed information pertaining to any of these options or accessories.



100CT & 800CT Common Characteristics

	Units	100CT		800CT	
		Precision	Standard	Precision	Standard
Performance					
Positional Repeatability (bidirectional)	x 0.001 in (µm)	± 0.12 (± 3.0)	± 0.47 (± 12)	± 0.05 (± 1.3)	± 0.2 (± 5)
Life @ rated Load Cap.	x 1 million in (km)	10 (254)	10 (254)	100 (2540)	100 (2540)
Duty Cycle	%	75	75	100	100
Acceleration (Max.)	in/sec ² (m/sec ²)	4.8 (1.2)	24 (0.6)	96 (2.4)	96 (2.4)
Maximum Screw Speed	rps	25	25	50	50
Motor Sizing					
Ballscrew Diameter	in (mm)	0.50 (12.7)	0.50 (12.7)	0.625 (15.9)	0.625 (15.9)
Drive screw Efficiency	%	30	30	90	80
Breakaway Torque (Max.)	oz-in (N-m)	16.5 (0.117)	16.5 (0.117)	17.6 (0.12)	26.4 (0.19)
Running Torque (Max.)	oz-in (N-m)	15 (0.106)	15 (0.103)	16.0 (0.11)	24.0 (0.17)
Coefficient of Friction - Linear Bearing		0.003	0.003	0.003	0.003

Screw Driven Tables

100CT Travel Dependent Characteristics

Travel in (mm)	Load Capacity lbs (kgf)			Accuracy x 0.001 in (µm)		Input Inertia** 10 ⁻³ oz.-in.-sec. ² (10 ⁻⁵ kg-m ²)	Carriage Weight lbs (kgf)	Total Weight lbs (kgf)
	Normal	Inverted	Axial	Positional	Straightness			
Precision Grade								
4 (100)	200 (90)	100 (45)	55 (25)	0.6 (16)	0.32 (8)	0.79 (0.56)	5.4 (2.4)	7.6 (3.4)
6 (150)	220 (100)	110 (50)	55 (25)	0.9 (24)	0.48 (12)	1.02 (0.72)	7.4 (3.4)	10.5 (4.8)
8 (200)	240 (108)	120 (54)	55 (25)	1.3 (32)	0.64 (16)	1.22 (0.86)	10.5 (4.8)	13.6 (6.2)
10 (250)	260 (118)	130 (59)	55 (25)	1.6 (40)	0.64 (16)	1.43 (1.01)	11.6 (5.3)	16.7 (7.6)
12 (300)	280 (128)	140 (64)	55 (25)	1.9 (48)	0.64 (16)	1.63 (1.15)	13.5 (6.1)	19.8 (9)
Standard Grade								
4 (100)	200 (90)	100 (45)	55 (25)	0.8 (20)	0.8 (20)	0.79 (0.56)	5.4 (2.4)	7.6 (3.4)
6 (150)	220 (100)	110 (50)	55 (25)	1.2 (30)	1.2 (30)	1.02 (0.72)	7.4 (3.4)	10.5 (4.8)
8 (200)	240 (108)	120 (54)	55 (25)	1.6 (40)	1.6 (40)	1.22 (0.86)	10.5 (4.8)	13.6 (6.2)
10 (250)	260 (118)	130 (59)	55 (25)	2.0 (50)	2.0 (50)	1.43 (1.01)	11.6 (5.3)	16.7 (7.6)
12 (300)	280 (128)	140 (64)	55 (25)	2.4 (60)	2.4 (60)	1.63 (1.15)	13.5 (6.1)	19.8 (9)

*For moment load calculations, refer to the technical section of Parker's web site www.parkermotion.com

**Input Inertia based on 0.2 inch lead ballscrew.

800CT Travel Dependent Characteristics

Travel in (mm)	Load Capacity* lbs (kgf)			Accuracy x 0.001 in (µm)		Input Inertia** 10 ⁻³ oz.-in.-sec. ² (10 ⁻⁵ kg-m ²)		Carriage Weight lbs (kgf)		Total Weight lbs (kgf)	
	Normal	Inverted	Axial	Positional	Straightness	6" Wide	8" Wide	6" Wide	8" Wide	6" Wide	8" Wide
Precision Grade											
4 (100)	200 (90)	100 (45)	200 (91)	0.32 (8)	0.32 (8)	2.33 (1.65)	2.38 (1.68)	5.4 (2.5)	7.2 (3.3)	12.4 (5.6)	16.6 (7.5)
6 (150)	220 (100)	110 (50)	200 (91)	0.48 (12)	0.48 (12)	2.73 (1.93)	2.80 (1.98)	6.6 (3.0)	9.2 (4.2)	14.6 (6.6)	20.0 (9.1)
8 (200)	240 (108)	120 (54)	200 (91)	0.60 (15)	0.64 (16)	3.14 (2.22)	3.23 (2.28)	7.6 (3.5)	10.8 (4.9)	15.8 (7.2)	23.3 (10.6)
10 (250)	260 (118)	130 (59)	200 (91)	0.60 (15)	0.80 (20)	3.55 (2.51)	3.64 (2.57)	8.7 (3.9)	12.5 (5.7)	19.8 (8.6)	26.7 (12.1)
12 (300)	280 (128)	140 (64)	200 (91)	0.60 (15)	0.96 (24)	3.95 (2.79)	4.06 (2.87)	10.0 (4.5)	14.1 (6.4)	21.6 (9.8)	30.0 (13.7)
Standard Grade											
4 (100)	200 (90)	100 (45)	200 (91)	0.60 (15)	0.32 (8)	2.33 (1.65)	2.38 (1.68)	5.4 (2.5)	7.2 (3.3)	12.4 (5.6)	16.6 (7.5)
6 (150)	220 (100)	110 (50)	200 (91)	0.9 (23)	0.48 (12)	2.73 (1.93)	2.80 (1.98)	6.6 (3.0)	9.2 (4.2)	14.6 (6.6)	20.0 (9.1)
8 (200)	240 (108)	120 (54)	200 (91)	1.0 (25)	0.64 (16)	3.14 (2.22)	3.23 (2.28)	7.6 (3.5)	10.8 (4.9)	15.8 (7.2)	23.3 (10.6)
10 (250)	260 (118)	130 (59)	200 (91)	1.0 (25)	0.80 (20)	3.55 (2.51)	3.64 (2.57)	8.7 (3.9)	12.5 (5.7)	19.8 (8.6)	26.7 (12.1)
12 (300)	280 (128)	140 (64)	200 (91)	1.0 (25)	0.96 (24)	3.95 (2.79)	4.06 (2.87)	10.0 (4.5)	14.1 (6.4)	21.6 (9.8)	30.0 (13.7)

*For moment load calculations, refer to the technical section of Parker's web site www.parkermotion.com

**Input Inertia based on 0.2 inch lead ballscrew.



106CT Dimensions

Dimensions - inches (mm)

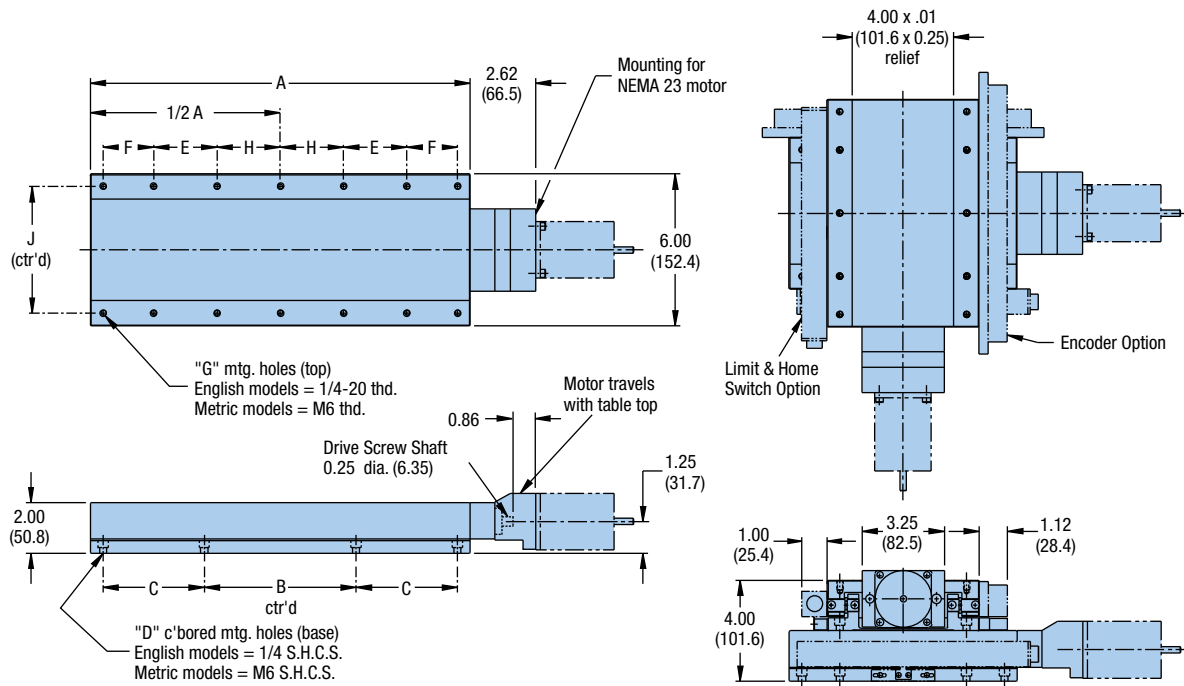

English Models

Model No.	Travel	A	B	C	Quantity D	E	F	Quantity G	H	J
106004	4 in	6 in	5 in	—	4	—	—	6	2.5 in	5.00 in
106006	6 in	9 in	5 in	1.5 in	8	1.5 in	—	10	2.5 in	5.00 in
106008	8 in	12 in	5 in	3 in	8	2.5 in	—	10	2.5 in	5.00 in
106010	10 in	15 in	6 in	4 in	8	2.5 in	2 in	14	2.5 in	5.00 in
106012	12 in	18 in	7 in	5 in	8	5 in	1 in	14	2.5 in	5.00 in

Metric Models

Model No.	Travel	A	B	C	Quantity D	E	F	Quantity G	H	J
106004	100 mm	152.4 mm	125.0 mm	—	4	—	—	6	62.5 mm	125.0 mm
106006	150 mm	228.6 mm	125.0 mm	37.5 mm	8	37.5 mm	—	10	62.5 mm	125.0 mm
106008	200 mm	304.8 mm	125.0 mm	75.0 mm	8	62.5 mm	—	10	62.5 mm	125.0 mm
1060010	250 mm	381.0 mm	150.0 mm	100.0 mm	8	62.5 mm	50.0 mm	14	62.5 mm	125.0 mm
1060012	300 mm	457.2 mm	175.0 mm	125.0 mm	8	125.0 mm	25.0 mm	14	62.5 mm	125.0 mm



806CT Dimensions

Dimensions - inches (mm)

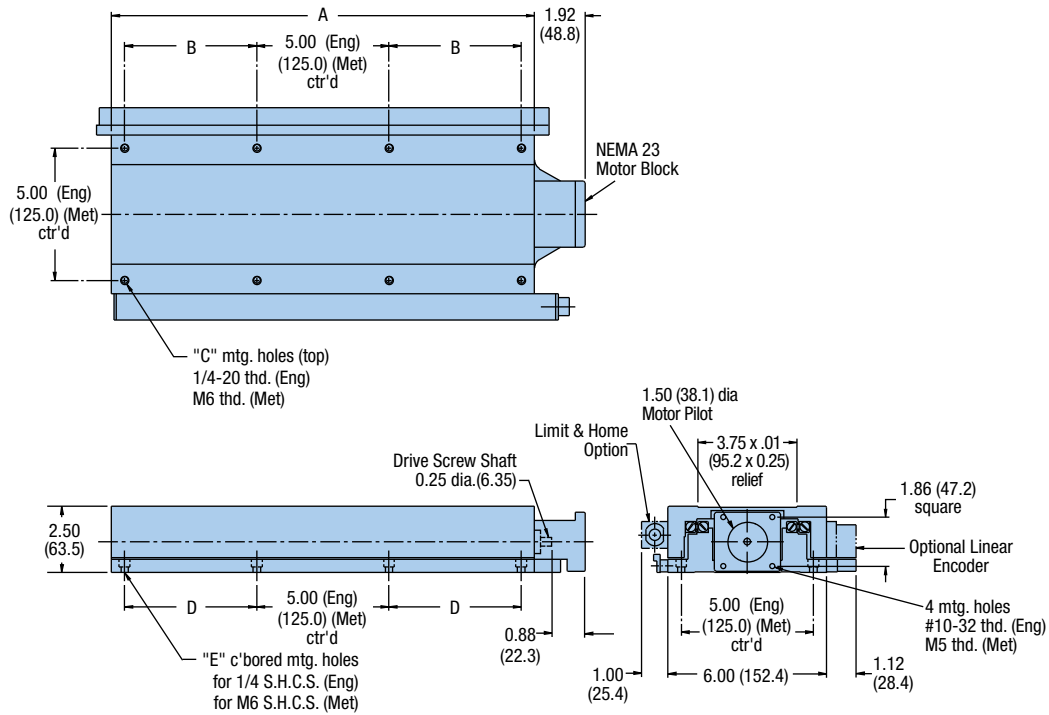

Screw Driven Tables

English Models

Model	Travel	A	B	C	D	E
806004CT-E	4.0	8.0	—	4	—	4
806006CT-E	6.0	10.0	2.0	8	2.0	8
806008CT-E	8.0	12.0	3.0	8	3.0	8
806010CT-E	10.0	14.0	4.0	8	4.0	8
806012CT-E	12.0	16.0	5.0	8	4.0	8

Metric Models

Model	Travel	A	B	C	D	E
806004CT-M	100	203.2	—	12	—	4
806006CT-M	150	254.0	—	12	50	8
806008CT-M	200	304.8	75	16	75	8
806010CT-M	250	355.6	100	16	100	8
806012CT-M	300	406.4	125	16	125	8

808CT Dimensions

Dimensions - inches (mm)

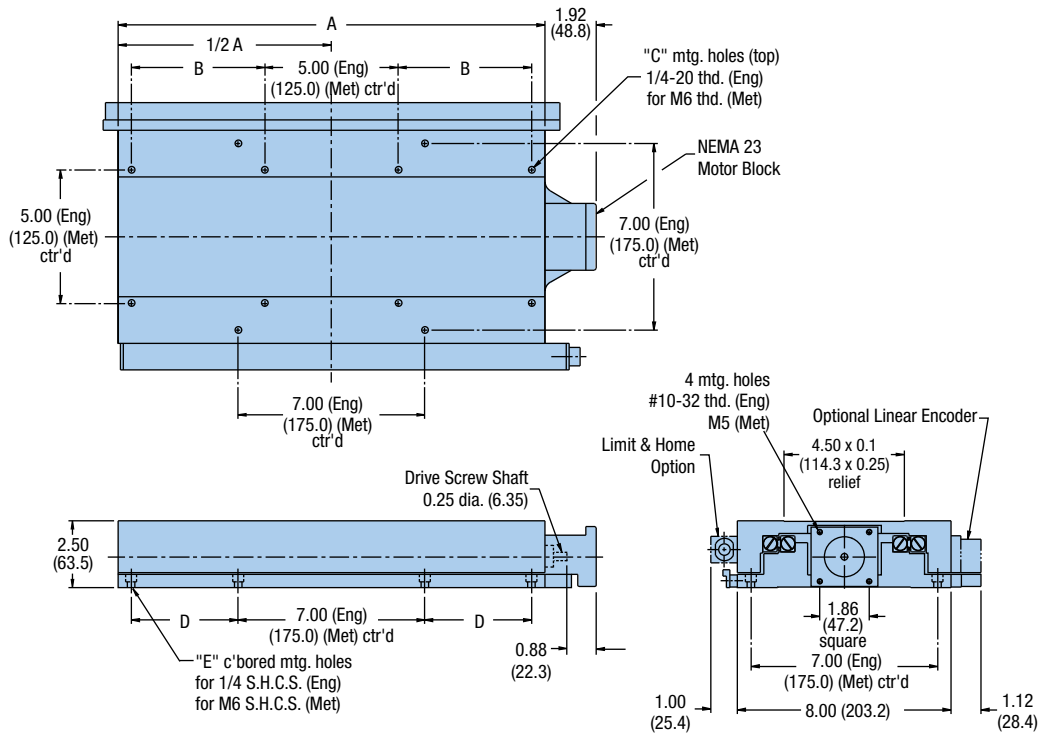

English Models

Model	Travel	A	B	C	D	E
808004CT-E	4.0	8.0	—	4	—	4
808006CT-E	6.0	10.0	2.0	8	2.0	8
808008CT-E	8.0	12.0	2.0	8	2.0	8
808010CT-E	10.0	14.0	4.0	8	4.0	8
808012CT-E	12.0	16.0	5.0	8	5.0	8

Metric Models

Model	Travel	A	B	C	D	E
808004CT-M	100	203.2	—	12	—	4
808006CT-M	150	254.0	—	12	50	8
808008CT-M	200	304.8	75	16	50	8
808010CT-M	250	355.6	100	16	100	8
808012CT-M	300	406.4	125	16	125	8



Fill in an order code from each of the numbered fields to create a complete model order code.

① ② ③ ④ ⑤ ⑥ ⑦ ⑧ ⑨ ⑩ ⑪

Order Example: 8 08 006 CT M P D2 L1 C2 M1 E2

① Series

1 100CT
8 800CT

② Table Width

06 6 in, 150 mm
08 200 mm (800 series)

③ Table Travel

004 4 in, 100 mm
006 6 in, 150 mm
008 8 in, 200 mm
010 10 in, 250 mm
012 12 in, 300 mm

④ Table Style

CT Cross roller bearing

⑤ Mounting

E English
M Metric (800CT only)

⑥ Grade

S Standard
P Precision

⑦ Drive Screw

100CT Series Designators

D1 0.02 in lead (50 pitch)
D2 0.10 in lead (10 pitch)
D3 0.20 in lead (5 pitch)
D4 1 mm lead
D5 2 mm lead
D6 5 mm lead
D7 0.1 in lead (ACME)
for vertical applications, motor up
D8 0.1 in lead (ACME)
for vertical applications, motor down

800CT Series Designators

D1 0.20 in lead ballscrew
D2 5 mm lead ballscrew

⑧ Limit/Home

L1 No limit/home switches
L2 Magnetic limit/home switches
L3 Optical limit/home switches

⑨ Motor Coupling

C1 No coupling
C2 0.25 in bore, helix, aluminum
C3 0.25 in bore, helix, stainless steel
C4 0.25 in bore, bellows, required for precision grade
C5 0.375 in bore, helix, aluminum
C6 0.375 in bore, helix, stainless steel
C7 0.375 in bore, bellows, required for precision grade

⑩ Motor Mount

M1 23 frame size

⑪ Encoder

E1 No encoder
E2 Linear encoder, English, 0.0001 in resolution
E3 Linear encoder, metric, 1 µm resolution

Screw Driven
Tables

200RT Series Rotary Tables

Features

- Highly repeatable indexing (12 arc-sec)
- Load capacities to 200 lbs
- 360 degrees continuous travel
- Performance tested worm gear drive
- Selectable table sizes and drive ratio
- Dual race angular contact support bearing

Quality Design and Construction

The 200RT Series Rotary Tables are designed for precise motor-driven rotary positioning and indexing. These tables are designed to function independently or in conjunction with linear tables used in the high-precision and precision automation applications. Their low profile design minimizes stack height in multi-axis configurations and enables them to fit in many places where other motorized rotary devices cannot.

Models are available in 5, 6, 8, 10, or 12 inch diameters and are offered with four gear ratios making it convenient to match size, speed, and load requirements. They can be selected in either English or metric mounting. They are found in virtually all industries where intermittent part indexing, part scanning, skew adjustment, or precise angular alignment is required.

At the heart of these tables is a rugged main support bearing which is comprised of two preloaded angular contact bearing races. It is designed for high load capacity and smooth, flat rotary motion. The drive is a precision worm gear assembly which is preloaded to remove backlash. The top and base are constructed of high quality aluminum with an attractive black anodized finish. The top and bottom mounting surfaces are precision ground to assure flatness.



Options and Accessories

Motor Couplings

A wide range of coupling styles and bores are available to match motor requirements. Bellows-style couplings, offering the lowest windup are required for all precision grade tables, while the aluminum and stainless steel helix couplers offer good windup characteristics and high durability at a lower cost.

Motor Mounts

The motor mount is designed for an industry standard NEMA 23 motor flange and a maximum shaft length of 0.85".

Home Sensor

The Home sensor provides a fixed reference point to which the table can always return. This is a mechanical reed switch which is mounted the body of the rotary table and is activated by a magnet imbedded on the table top.

Rotary Encoders

High resolution, high accuracy rotary encoders can be added for direct positional feedback of the table top position. Rotary encoders can be mounted directly to the base of the rotary table. The encoder input shaft is then coupled directly to the rotary table top, supplying positional feedback of the table top, with no drive train errors. They can be supplied with or without a base housing which encloses and protects the encoder.

Seals

Custom designed sealed units are offered to prevent excessive wear or internal damage resulting from dust and contaminates.

Motors, Drives & Controls

Micro-step motors with drives are available for direct mounting to the rotary tables. Motion controllers can also be added to provide systems with seamless connectivity.

High Performance Direct Drive Rotary Tables

Parker's DM1004 direct drive brushless servo motor tables offer an alternative to the 200RT series for high throughput precision indexing.

Visit our website for complete information.





200RT Common Characteristics

	Units	Precision	Standard
Positional Repeatability (unidirectional)	arc-min	0.2	0.5
Duty Cycle	%	50	50
Table Runout (Max.)	in (µm)	±0.001 (±25)	±0.003 (±75)
Concentricity	in (µm)	±0.001 (±25)	±0.005 (±127)
Wobble	arc-sec	30	60
Input Velocity (Max.)	revs./sec.	15	15

Travel Dependent Characteristics

Table Diameter inches	Drive Ratio	Load Capacity lbs (kgf)	Accuracy arc-min		Output Torque in-lb (N-m)	Inertia 10 ⁻³ -oz.-in-sec ² (10 ⁻⁶ kg-m-sec ²)	Input Breakaway Torque (max.) oz.-in (N-m)	Running Torque (max) oz-in (N-m)	Weight lb (kgf)	
			Precision	Standard					Standard Top	Total
5.0	180:1	25 (11)	3	10	25 (2.8)	0.14 (0.102)	22 (0.16)	20 (0.13)	0.67 (0.3)	6.0 (2.7)
5.0	90:1	25 (11)	3	10	25 (2.8)	0.15 (0.112)	22 (0.16)	20 (0.13)	0.67 (0.3)	6.0 (2.7)
5.0	36:1	25 (11)	5	12	25 (2.8)	0.24 (0.173)	22 (0.16)	20 (0.13)	0.67 (0.3)	6.0 (3.6)
6.0	180:1	150 (68)	3	10	40 (4.5)	0.16 (0.112)	22 (0.16)	20 (0.13)	0.91 (0.42)	8.0 (2.7)
6.0	90:1	150 (68)	3	10	40 (4.5)	0.20 (0.132)	22 (0.16)	20 (0.13)	0.91 (0.42)	8.0 (3.6)
6.0	45:1	150 (68)	5	12	40 (4.5)	0.29 (0.204)	22 (0.16)	20 (0.13)	0.91 (0.42)	8.0 (3.6)
8.0	180:1	150 (68)	3	10	40 (4.5)	0.24 (0.163)	28 (0.19)	25 (0.18)	2.23 (1.01)	15.0 (6.8)
8.0	90:1	150 (68)	3	10	40 (4.5)	0.66 (0.459)	28 (0.19)	25 (0.18)	2.23 (1.01)	15.0 (6.8)
8.0	36:1	150 (68)	5	12	40 (4.5)	0.90 (0.642)	28 (0.19)	25 (0.18)	2.30 (1.05)	15.0 (6.8)
10.0	180:1	200 (90)	3	10	190 (21.5)	0.74 (0.530)	33 (0.22)	30 (0.21)	5.26 (2.30)	29.0 (13.1)
10.0	90:1	200 (90)	3	10	190 (21.5)	1.02 (0.734)	33 (0.22)	30 (0.21)	5.26 (2.30)	29.0 (13.1)
10.0	45:1	200 (90)	5	12	190 (21.5)	2.13 (1.53)	33 (0.22)	30 (0.21)	5.26 (2.30)	29.0 (13.1)
12.0	180:1	200 (90)	3	10	190 (21.5)	0.99 (0.713)	33 (0.22)	30 (0.21)	7.67 (3.49)	32.0 (14.5)
12.0	90:1	200 (90)	3	10	190 (21.5)	1.59 (1.12)	33 (0.22)	30 (0.21)	7.67 (3.49)	32.0 (14.5)
12.0	45:1	200 (90)	5	12	190 (21.5)	3.83 (2.75)	33 (0.22)	30 (0.21)	7.67 (3.49)	32 (14.5)

NOTE: For moment load calculations, refer to the technical section of Parker's web site www.parkermotion.com

Screw Driven Tables

200RT Series Dimensions

Dimensions - inches (mm)

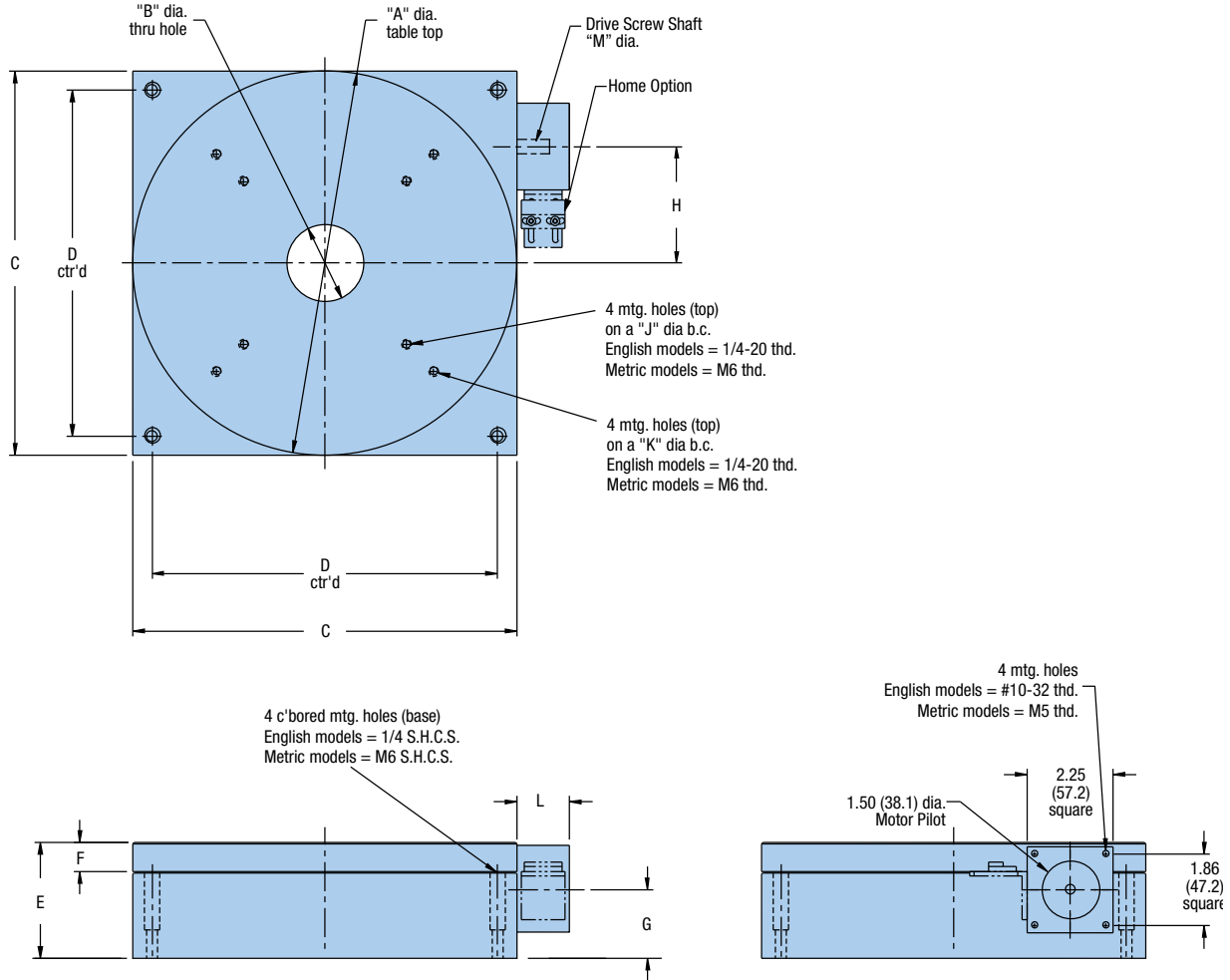

English Units

A	B	C	D	E		F		G	H	J	K	L	M
				Standard	Option	Standard	Option						
				(T2)	(T3)	(T2)	(T3)						
5.0	1.0	5.0	4.0	1.8	2.42	0.38	1.00	1.11	1.66	3.0	4.0	1.38	0.188
6.0	1.75	6.0	5.0	2.0	2.62	0.38	1.00	1.23	2.04	4.0	5.0	1.38	0.25
8.0	1.75*	8.0	6.0	2.5	3.12	0.50	1.00	1.57	2.04	4.0	6.0	1.38	0.25
10.0	2.0	10.0	9.0	3.0	3.62	0.75	1.00	1.81	3.03	6.0	8.0	1.38	0.25
12.0	2.0	10.0	9.0	3.0	3.62	0.75	1.00	1.81	3.03	8.0	10.0	2.38	0.25

*On the 8.0" (203,2) diameter table with 36:1 ratio, this dimension is 1.0" (25,4).

Metric Units

A	B	C	D	E		F		G	H	J	K	L	M
				Standard	Option	Standard	Option						
				(T2)	(T3)	(T2)	(T3)						
127.0	25.4	127.0	100	46.0	61.5	9.6	25.0	28.1	42.1	75	100	35	4.76
152.4	44.5	152.4	125	50.8	66.5	9.6	25.0	31.4	51.8	100	125	35	6.35
203.2	44.5*	203.2	175	63.5	79.2	12.7	25.0	39.8	51.8	100	150	35	6.35
254.0	50.8	254.0	225	76.2	91.9	19.0	25.0	45.9	76.9	150	200	35	6.35
304.8	50.8	254.0	225	76.2	91.9	19.0	25.0	45.9	76.9	200	250	60.4	6.35

*On the 8.0" (203,2) diameter table with 36:1 ratio, this dimension is 1.0" (25,4).



Fill in an order code from each of the numbered fields to create a complete model order code.

① ② ③ ④ ⑤ ⑥ ⑦ ⑧ ⑨ ⑩ ⑪

Order Example: 2 08 01 RT M S H1 C1 M1 E1 T1

① Series

2

② Table Diameter

05 5 in, 125 mm
 06 6 in, 150 mm
 08 8 in, 200 mm
 10 10 in, 250 mm
 12 12 in, 300 mm

③ Gear Ratio

01 180:1, Available on all dia.
 02 90:1, Available on all dia.
 04 45:1, Available on 6", 10" and 12" dia. only
 05 36:1, Available on 5" and 8" dia. only

④ Table Style

RT

⑤ Mounting

E English
 M Metric (800CT only)

⑥ Grade

S Standard
 P Precision

⑦ Home

H1 No home switches
 H2 Magnetic home switches

⑧ Motor Coupling

C1 No coupling
 C2 0.25 in bore, helix, aluminum
 C3 0.25 in bore, helix, stainless steel (not available on 205 model)
 C4 0.25 in bore, bellows, required for precision grade
 C5 0.375 in bore, helix, aluminum
 C6 0.375 in bore, helix, stainless steel (not available on 205 model)
 C7 0.375 in bore, bellows, required for precision grade

⑨ Motor Mount

M1 23 frame size

⑩ Encoder

E0 No encoder
 E8 Ring encoder – 314,880 post quad. counts/rev
 E9 Ring encoder – 3,148,800 post quad. counts/rev

⑪ Table Top

T1 No top
 T2 Standard top
 T3 Oversized top (raises height to clear NEMA 23 motor)

Screw Driven
Tables

Rotary Series Worm Drive Precision Stages

The Rotary Stage Series offers an unparalleled combination of high accuracy and high load capacity. These rotary stages utilize a precision worm gear with the worm “flexed” against the gear to ensure a proper mesh. This feature provides high repeatability with very smooth operation. Additionally, the rotary stages incorporate an oversized preloaded cross roller bearing, offering exceptional stiffness and load capacity.

- Unique self-compensating preload to limit backlash
- Solid or thru bore construction
- Robust bearing design for high-load capacity
- Built-in limit switches
- Aluminum construction with stainless steel top plate

When to Use

- High accuracy
- High loads
- Compact
- High stiffness

Applications

- Electronic assembly
- Fiber optics
- Medical
- Packaging
- Pharmaceutical
- Robotics
- Semiconductor

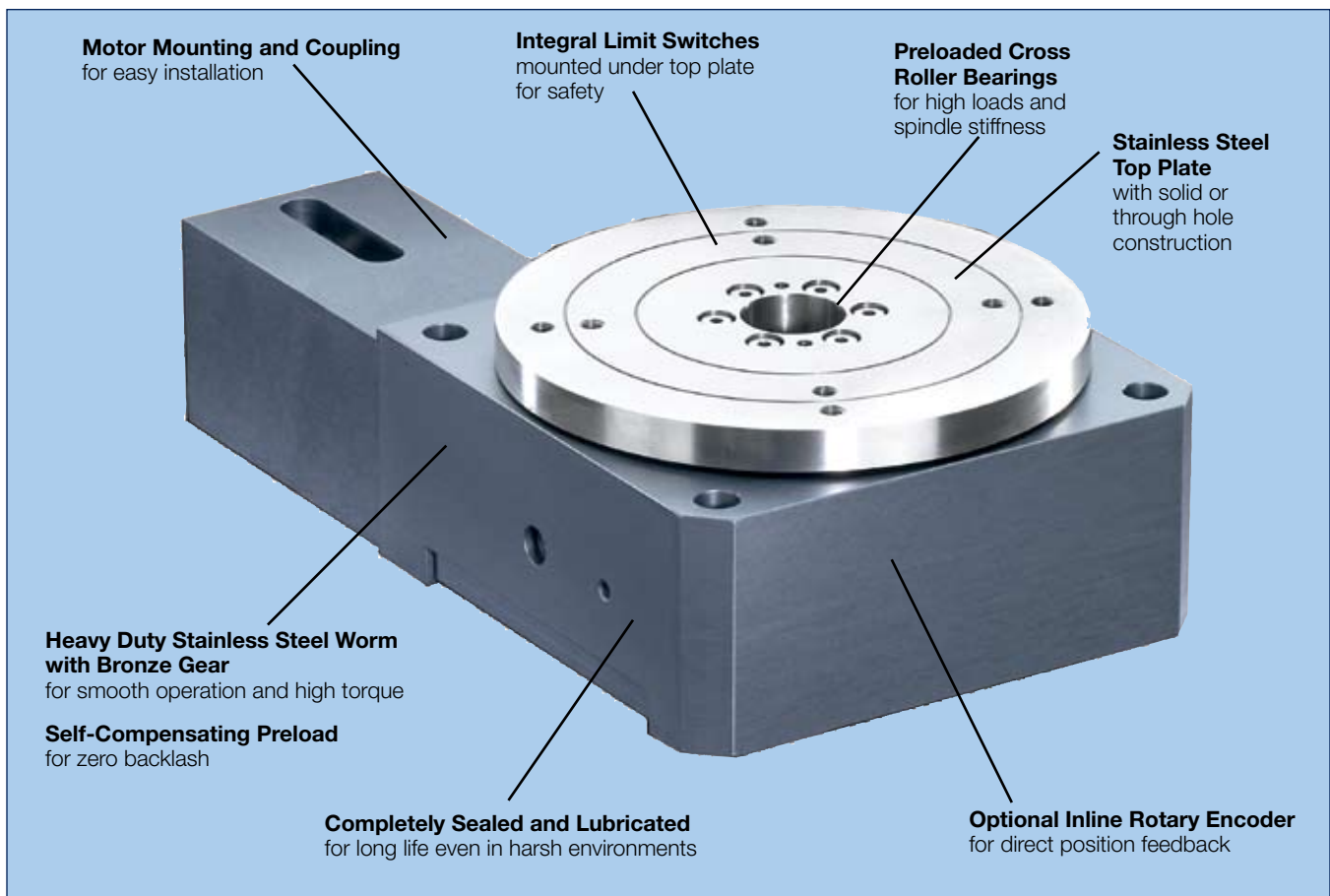

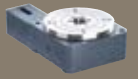

Rotary Series Specifications

Performance Specifications

Model No.	Axial Capacity		Perpendicular Capacity			
	(kg)	(lb)	@ 25 mm		@150 mm	
	(kgf)	(lb)	(kgf)	(lb)	(kgf)	(lb)
R100M	100	220	22	48	7	15
R150M	400	880	88	194	33	73
R200M ⁴	600	1320	200	440	85	187
R300M	1000	2220	325	715	160	352

Model No.	Worm Gear Ratio	Gearing Backlash ⁽²⁾ (arc-sec)	Peak Output Torque @100 RPM Input		Peak Output Speed (RPM)	Weight		Inertia	
			(Nm)	(in-lb)		(kgf)	(lbf)	gm-cm sec ²	oz-in sec ²
RM100	60:1	2	8	70.8	30	2.3	5.0	0.0057	0.0000784
R150M	72:1	2	25	221	30	6.0	13.0	0.055	0.00076
R200M ⁴	72:1	2	55	487	30	15.0	33.0	0.148	0.00210
R300M	90:1	2	75	664	30	35.0	77.0	0.368	0.00516

Screw Driven Tables

Accuracy Specifications⁽²⁾

	Main Bearing Runout	Top to Base Parallelism	Position ⁽³⁾ Accuracy	Position ⁽³⁾ Repeatability	Input Torque Required	
	(microns)	(microns)	(arc-min)	(arc-sec)	(Nm)	(in-oz)
R100M	±5	±12	2	12	0.07	20
R150M	±5	±12	2	12	0.14	20
R200M ⁴	±7	±17	2	12	0.14	20
R300M	±10	±25	2	12	0.21	30

- (1) Gearing backlash is uni-directional.
- (2) Accuracy is based on stage mounted to a flat granite surface and measured at 25 mm above the center of the stage.
- (3) Accuracy and repeatability are based on open loop lead accuracy and can be enhanced with encoder feedback.
- (4) See 200RT Series page 134.



Rotary Series Dimensions

Dimensions (mm)

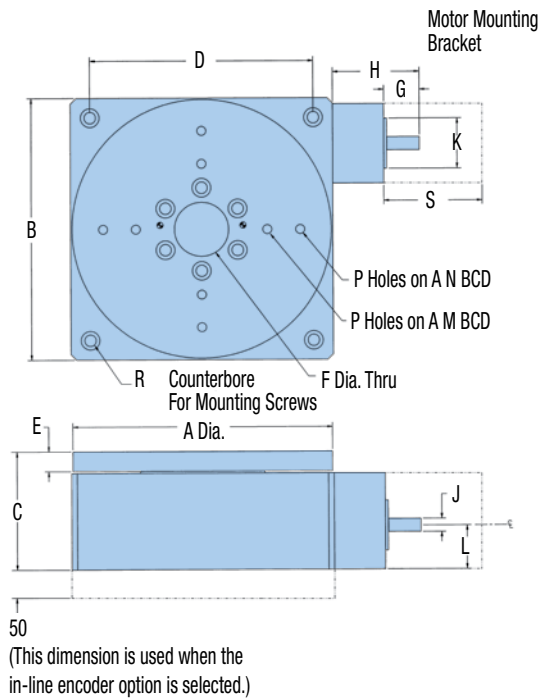

Model No.	A		B		C		D		E	
	(mm)	(in)	(mm)	(in)	(mm)	(in)	(mm)	(in)	(mm)	(in)
R100M	98.5	3.88	100	3.94	55	2.16	85	3.35	8	0.32
R150M	147.6	5.81	150	5.90	75	2.95	125	4.92	11	0.43
R200M	197.7	7.78	200	7.87	90	3.54	170	6.70	15	0.59
R300M	297.7	11.72	300	11.81	108	4.25	270	10.63	16	0.63

Model No.	F		G		H		J		K	
	(mm)	(in)	(mm)	(in)	(mm)	(in)	(mm)	(in)	(mm)	(in)
R100M	12	0.47	15	0.59	45	1.77	5	0.197	18	0.709
R150M	25.5	1.00	27	1.06	66	2.60	10	0.394	38.1	1.50
R200M	38	1.50	27	1.06	66	2.60	10	0.394	38.1	1.50
R300M	51	2.00	39	1.53	113	4.45	12	0.472	73	2.875

Model No.	L		M		N		P	R	S		Stage Weight	
	(mm)	(in)	(mm)	(in)	(mm)	(in)	Tap	CBore	(mm)	(in)	(kg)	(lb)
R100M	21	0.83	45	1.772	75	2.953	M5 x 0.8	M5	38.1	1.50	1.8	3.97
R150M	30.1	1.18	100	3.937	125	4.921	M6 x 1	M6	60.2	2.37	5	11
R200M	33.5	1.32	100	3.937	150	5.905	M8 x 1.25	M8	60.2	2.37	13	28.66
R300M	44.2	1.74	150	5.905	250	9.843	M8 x 1.25	M8	73.1	2.88	29	63.93

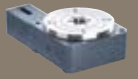

Fill in an order code from each of the numbered fields to create a complete model order code.

① ② ③ ④ ⑤ ⑥ ⑦ ⑧

Order Example: R 150 M 3 2 2 1 2

① **Series**

R Worm Gear Rotary Series

② **Metric Square Width**

100 100 mm
150 150 mm
200⁽¹⁾ 200 mm
300 300 mm

③ **Drive**

M Separate Motor

④ **Gear Ratio**

2 60:1 (R100)
3 72:1 (R150 and R200)
4 90:1 (R300)

⑤ **Motor Mounting**

X See how to order step 2

⑥ **Limits Switches**

1 None
2 End of travel
3 End of travel and home

⑦ **Encoder in Line with Top Plate**

1 None
3 200 LPR

⑧ **Environment**

1 Standard
2 Cleanroom

(1) See page 134 for 200RT series rotary tables.

ZP200 Series Vertical Lift “Wedge” Table

Features

- Precision platform for vertical (Z-axis) positioning
- Continuous duty - High dynamic performance
- Precision straightness (± 5 arc-sec) throughout range of motion
- Precision ground ballscrew drive - 5, 10, or 20 mm lead
- Multi-axis compatibility with XR and LXR tables
- Laser tested and certified with calibrated lead value

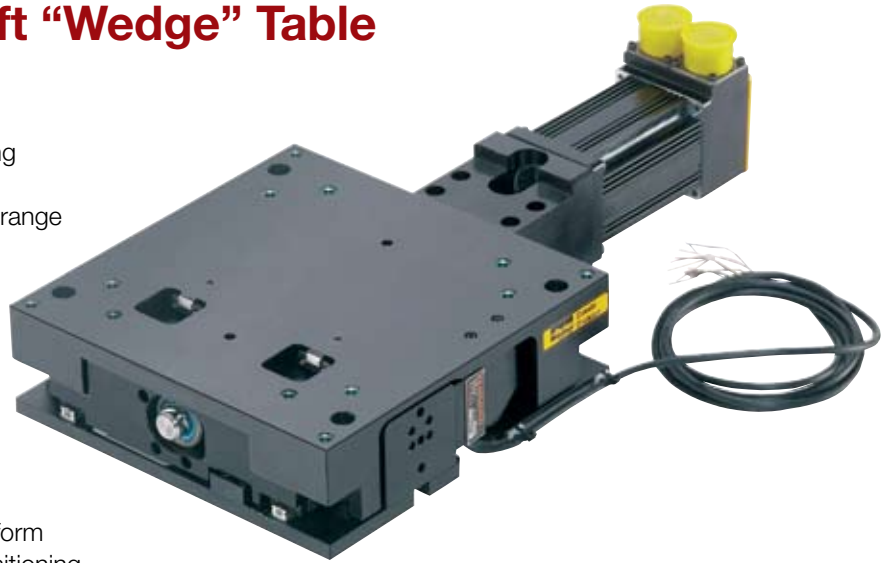

Quality Design and Construction

The ZP200 Z axis lift table is a stable support platform which provides precise vertical translation and positioning, while maintaining X-Y integrity. Recirculating square rail bearings are incorporated into a unique variation of “wedge” mechanics to enable reliable high dynamic performance without the potential loss of travel encountered with cross roller bearings. The ZP200 is compatible with XR and LXR tables for multi-axis systems, and it can be utilized as the system base axis or top axis to fit the motion requirements of the application. Standard mounting holes and dowel pin holes accommodate repeatable mounting.

Options

- Linear Encoder option with selectable resolutions of 0.1, 0.5, 1.0 μm
- Fail-safe brake (field installable - mounts directly to the ballscrew drive)
- Class 10 cleanroom preparation
- Selectable motor mounting and couplings for SM16 or NEMA 23 servo or stepper motors
- Easily adjusted travel “limit” and “home” sensors are provided in an enclosed sensor pack

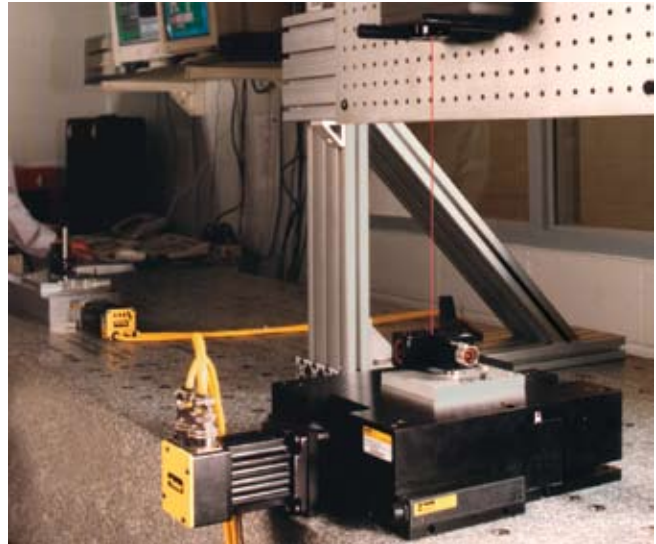

ZP200 utilized in a laser test set-up

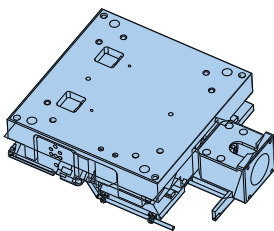

Encoder

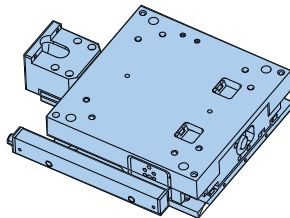

Sensor Pack



ZP200 Specifications

	Precision	Standard
Travel (Z-axis)	25 mm (limit to limit)	25 mm (limit to limit)
Positional Accuracy		
with no encoder ^{1,2,7}	8 μm	20 μm
with linear encoder ^{3,6,7}	8 μm	—
Positional Repeatability		
with no encoder ^{1,7}	± 3 μm	± 10 μm
with 1.0 μm linear encoder ^{6,7}	± 5 μm	—
with 0.5 μm linear encoder ^{6,7}	± 4 μm	—
with 0.1 μm linear encoder ^{6,7}	± 3 μm	—
Lift Lead Ratio ⁴		
5 mm lead ballscrew drive	1.8199 mm/rev	
10 mm lead ballscrew drive	3.6397 mm/rev	
20 mm lead ballscrew drive	7.2794 mm/rev	
Lift Velocity		
5 mm lead ballscrew drive	110 mm/sec	
10 mm lead ballscrew drive	220 mm/sec	
20 mm lead ballscrew drive	440 mm/sec	
Load Capacity (normal)	15 kg (33 lb)	75 kg (165 lb)
Duty Cycle	100%	
Max Acceleration	7.2 m/sec ²	
Efficiency	90%	
Max Breakaway Torque ⁵	0.15 Nm	
Max Running Torque ⁵	0.13 Nm	
Linear Bearing – Coefficient Of Friction	0.01	
Ballscrew Diameter	16 mm	
Unit Weight	5.82 kg	
Top Plate Weight	2.25 kg	
Pitch ⁷	± 15 Arc-sec	± 45 Arc-sec
Roll ⁷	± 15 Arc-sec	± 25 Arc-sec
Input Inertia		
5 mm lead ballscrew drive	2.32 x 10 ⁻⁵ Kg-m ²	
10 mm lead ballscrew drive	2.51 x 10 ⁻⁵ Kg-m ²	
20 mm lead ballscrew drive	3.12 x 10 ⁻⁵ Kg-m ²	

Screw Driven Tables

- 1) Measured 38 mm directly above the true center of the top mounting surface.
- 2) Measured using calibrated lead value (provided).
- 3) Slope correction value provided
- 4) Lift per 1 motor shaft revolution. Lift lead listed is nominal. All units are provided with calibrated lead value.
- 5) Torque ratings are measured with unit unloaded, traveling upward.
- 6) Measured directly over encoder on outer edge.
- 7) Pitch and Roll Specifications are measured with <1kg load. Addition of load increases pitch and roll error by 10 arc-sec per 5 kg of load assuming the load center of gravity is located at the center of the stage platform. Cantilevered loading increases these errors more.

Table Life/Compression (Normal) Load

The graph provides a preliminary evaluation of the support bearing life/load characteristics. The curves show the life/load relationship when the applied load is centered on the carriage, normal (perpendicular) to the carriage mounting surface. For final evaluation of life vs load, including off center, tension, and side loads contact Parker Applications Engineering at 800-245-6903.

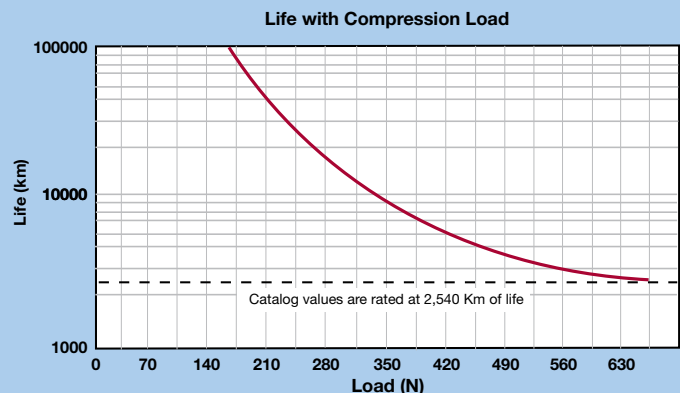

ZP200 Series Dimensions

Dimensions - inches (mm)

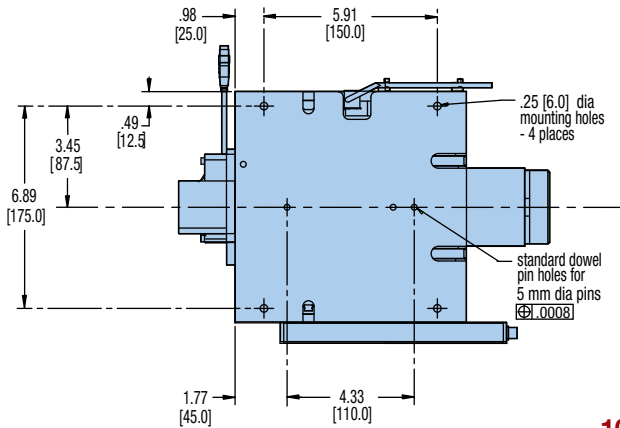
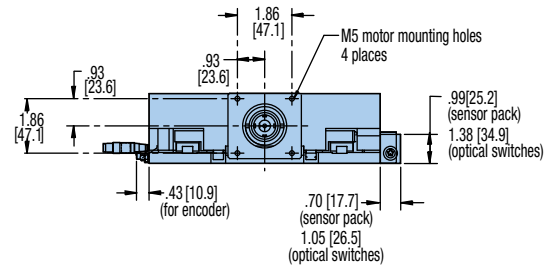
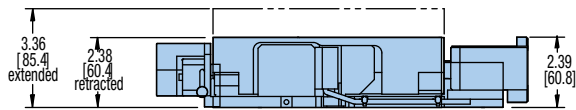
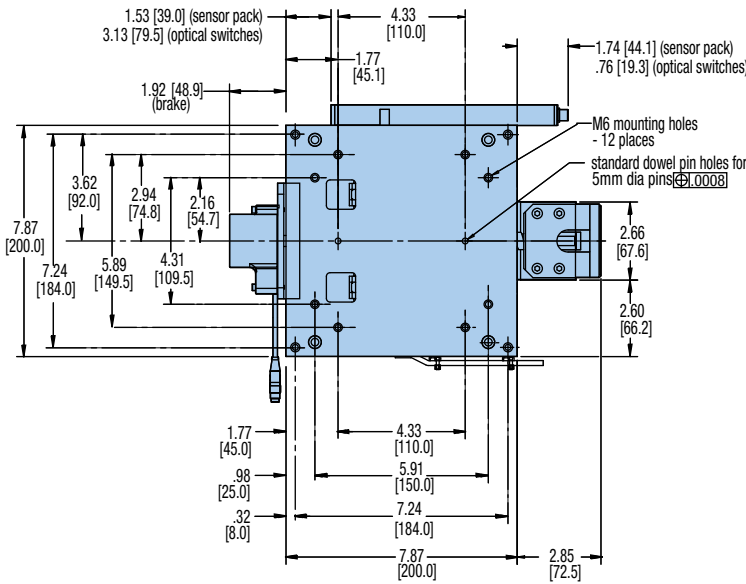

100-9274-01 XR Adapter Plate

A multi-axis adapter plate is available to mount the ZP200 to an XR/LXR table or, mount an XR/LXR table to the ZP200. This plate is 9.53 mm thick and includes standard dowel pin holes for repeatable alignment.

	ZP200 as Base	ZP200 as Top Axis
404XR	Yes	—*
404LXR	Yes	—*
406XR	Yes	Yes
406LXR	Yes	Yes
206 Rotary	Yes	—*

*Not recommended - consult factory.



Fill in an order code from each of the numbered fields to create a complete model order code.

① ② ③ ④ ⑤ ⑥ ⑦ ⑧ ⑨ ⑩ ⑪ ⑫ ⑬

Order Example: ZP200 T01 M S D2 H12 L12 C3 M3 E3 B2 R1 P1

① **Series**
ZP200

② **Travel**
T01 25 mm

③ **Mounting**
M Metric

④ **Grade**
P Precision
S Standard

⑤ **Drive Screw**
D2 5 mm lead
D3 10 mm lead
D4 20 mm lead

⑥ **Home Sensor**
H1 No sensor
H11 N.C. current sinking, sensor pack
H12 N.O. current sinking, sensor pack
H13 N.C. current sourcing, sensor pack
H14 N.O. current sourcing, sensor pack

⑦ **Travel Limit Sensors**
L1 No sensor
L11 N.C. current sinking, sensor pack
L12 N.O. current sinking, sensor pack
L13 N.C. current sourcing, sensor pack
L14 N.O. current sourcing, sensor pack

⑧ **Coupling**
C1 No coupling
C3 0.25" bore bellows
C5 0.38" bore bellows
C23 9.0 mm (0.35") bore bellows

⑨ **Motor Mount**
M1 No motor mounts
M2 SM16/BE16 motor
M3 NEMA 23 and SM23 motors
M61 BE23 motor mount

⑩ **Linear Encoder Option**
E1 No encoder
E2 1.0 micron
E3 0.5 micron
E4 0.1 micron
E5 5.0 micron
E7 Sine/cosine encoder

⑪ **Brake Option**
B1 No brake
B2 Shaft brake

⑫ **Environmental**
R1 Class 1000
R2 Class 10

⑬ **P1** Place holder

Screw Driven
Tables

Additional Screw Driven Products

In addition to the precision tables previously described in this section, Parker offers additional products which enhance the overall capability of this product family. The table products shown on the following pages expand the range of performance features, and are used extensively as the mechanical subsystem in OEM applications.

The motors, drives and controls are presented to increase awareness of Parker's electrical subsystems which are incorporated into the control element of a system. More information is available on these products in the Drives and Controllers section of this catalog.

Visit our website at www.parkermotion.com for complete specifications on these products, PDF data sheets and CAD drawing downloads.

100BT Series

(pdf available on our website)

- Non-recirculating linear ball bearing for smoothest linear translation
- Precision ground leadscrew drive for accurate, repeatable positioning of ± 0.00012 in (bidirectional)
- Selectable drive screw leads to match speed and resolution requirements
- Travels up to 12 inches

The 100BT Series Linear Tables incorporate a non-recirculating linear ball bearing system to produce extremely smooth linear translation with excellent straightline and flatness accuracy. The drive mechanism is a precision ground leadscrew which is pre-loaded to provide highly precise positional accuracy and repeatability. Offered in English or metric versions, these tables are utilized in high to ultra high-end applications requiring accurate positioning over a relatively short distance at slow to moderate speeds and accelerations. In addition to the precision grade models, this series is also offered in standard grade models which permit cost savings to be realized in less demanding applications.



Table housings are constructed of high quality aluminum alloy and are protected with a black anodized surface finish. The top and bottom mounting surfaces are precision ground to assure flatness. The low-profile design and lightweight construction make the 100BT well suited for multi-axis applications. These tables are designed for use in clean environments and are typically found in the semiconductor, aerospace, instrumentation, and scientific industries. Typical applications include: Parts Inspection, Vision Systems, and Gauging. Scanning and Crystal Growing are also popular uses for these tables since they require extremely smooth and very precise motion.

300AT Series

(pdf available on our website)

- Large clear aperture
- Travel ranges up to 24 in x 24 in
- Non-recirculating linear ball bearing for smoothest linear translation
- Precision ground leadscrew drive for accurate, repeatable positioning (± 0.00012 in)
- Single and dual axis models

The 300AT Series Linear Tables, like the 100BT Series Tables incorporate a non-recirculating linear ball bearing system to produce extremely smooth linear translation with excellent straightline and flatness accuracy. They also offer a precision ground leadscrew drive mechanism which is preloaded to provide highly precise positional accuracy and repeatability.

The 300AT, however, has the drive mechanism located on the side of the unit to allow for a clear opening through the center of the table(s). This center opening (aperture) enables these tables to be utilized in a variety of applications where light or objects can pass through the table. These include component insertion and assembly, back-lit inspection, and scanning applications.



Table elements are constructed of high quality aluminum alloy and are protected with black anodized surface finish. The top and bottom mounting surfaces are precision machined to assure flatness, and fixturing holes are fitted with locking steel threaded inserts. These units are offered in English or metric versions, and in two grades: precision grade and standard grade which permit cost savings to be realized in less demanding applications.

Screw Driven
Tables

Low Profile X-Y Inspection Positioners

These two axis units provide a very low profile (under 2 inches) making them ideal for height restricted applications such as microscope inspection. They have a square rail bearing system and precision ballscrew drive and have been utilized in other applications including wafer inspection and handling, mask & die inspection, and cell counting & analysis. Custom design with a work envelope thickness less than 40 mm.

Travel Range: 12 in x 12 in
 Load Capacity: 30 pounds
 Maximum Speed: 10 in./sec.
 Duty Cycle: 100%
 Repeatability: ± 0.00008 in.
 Drive Type: Ground ballscrew

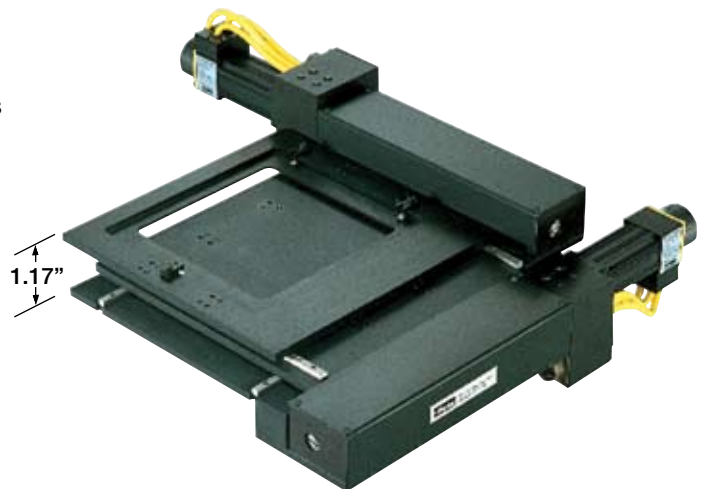

402LN Series Miniature Tables

(pdf available on our website)

- Compact size
- Ballscrew or leadscrew drive
- New 8 mm lead ballscrew
- High strength square rail bearing system
- Life rating: 10 million inches (ballscrew)
- Protective bellows style way cover

This series of compact tables are the smallest motorized linear positioners in the Parker line. These all metric units are designed for repeatable positioning of light payloads over relatively short distances. A dual track square rail bearing system, a ballscrew or leadscrew drive mechanism, and integral protective way covers are all contained within a table housing having a cross section of only 33 mm X 60 mm. The 402LN is utilized in applications requiring horizontal, inverted, or vertical translation, and is offered in two grades (precision or standard) to provide cost vs performance alternatives.



400ST Series Square Rail Linear Tables

(pdf available on our website)

- Load capacity to 2300 pounds
- Repeatability of ± 0.0001 inches (bidirectional)
- Large moment capacity
- Travels up to 60 inches
- Standard widths to 24 inches
- 100% duty cycle

Tables in the 400ST Series, Parker's most rugged and durable table line, are designed for precise positioning of very heavy loads (up to 1,500 pounds). By combining a high strength square rail bearing system with highly accurate precision ground ballscrew drives, these units provide the best solution for demanding applications in the high-precision and precision automation markets.

Tables in this series are offered in widths of 8, 12, 18 and 24 inches, and can be equipped with heavy-duty protective bellows for dirty or dusty environments. Typical applications include X-ray Scanning, Laser Machining, Laser Welding, and surface inspection. They have found popularity in a wide range of industries including Machine Tool, Automotive, Biomedical and Aerospace.

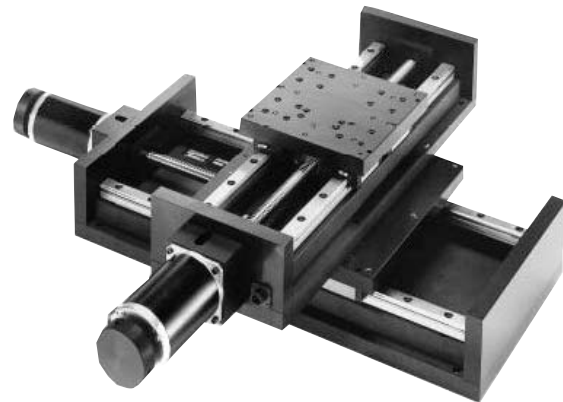

The top and base are constructed of high quality aluminum alloy and are protected with a black anodized surface finish. The top and bottom mounting surfaces are precision ground to assure flatness and all mounting holes are fitted with locking steel threaded inserts to prevent mounting bolts from working loose.

The linear guide ways utilize 1 inch square hardened steel rails, with four bearing trucks on the 8" and 12" wide units and six bearing trucks on the 18" and 24" wide units. The carriage is driven by a 0.2 inch lead (5 pitch) precision ground ballscrew secured at both ends by precision grade angular contact bearings.

406LN Square Rail Linear Tables

(pdf available on our website)

The 406LN is the proven performer where aggressive acceleration and exceptional accuracy are required in moving light to heavy loads over travels up to 24 inches. It is the table of choice for OEMs and integrators involved with semiconductor processing, PCB staking, and part insertion. The 406LN can be provided with or without linear encoder feedback, and is ready for direct hook-up with NEMA 23 or 34 frame size motors.

Travel Range: 24 inches
 Load Capacity: 600 pounds
 Maximum Speed: 12 in./sec.
 Duty Cycle: 100%
 Repeatability: ± 0.00005 in.
 Drive Type: Ground ballscrew



Screw Driven
Tables

500ET & 500ST Round Rail Tables

(pdf available on our website)

Are low-cost, multi-functional linear tables for applications having a load requirement of 200 lb or less. With a round rail bearing system, rolled ballscrew drive and either hard cover or bellows protection, the 500ET and 500ST tables are well suited for industrial and automation applications. Applications include parts transfer, cutoff machines, part loading, fluid dispensing, and light duty machining.

Travel Range: 60 inches
 Load Capacity: 200 pounds
 Maximum Speed: 25 in./sec.
 Duty Cycle: 100%
 Repeatability: ± 0.0006 in.
 Drive Type: Rolled Ballscrew

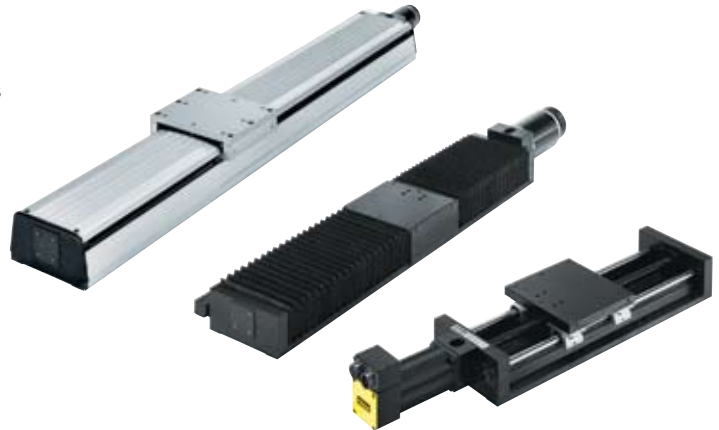

500PD Round Rail Tables

(pdf available on our website)

The 500PD combines a round rail bearing system with a steel reinforced timing belt drive to high-speed linear translation up to 120 in/sec and positional repeatability of ± 0.004 inches. They have been utilized by OEMs for uses in part transfer, pick-and-place, and high-speed scanning.

Travel Range: 60 inches
 Load Capacity: 200 pounds
 Maximum Speed: 120 in./sec.
 Duty Cycle: 100%
 Repeatability: ± 0.004 in.
 Drive Type: Belt



Motors, Drives and Controllers

Digital drives provide a robust and cost-effective system by power matching the drive with the application requirements. Designed with an open architecture in mind, drives can be configured for use Parker or any other manufacturer's motion controller.

For complete details on drive product features and specifications, please refer to the "Drives & Controllers" section of this catalog.



Miniature Positioners

linear motor and screw driven stages

Miniaturization of fiber optics, photonics, electronics and biomedical processes has driven the need for smaller and more efficient positioners. Parker offers numerous miniature stage solutions.



Contents

152-153	Overview
154-161	MX80L Linear Motor Driven Stages
162-167	MX80S Ballscrew/Leadscrew Driven Stages
166-171	MX80M Free Travel & Micrometer Driven
172-179	LX80L Linear Motor Tables
180-187	PROmech™ LP28 Miniature Linear Positioners
188-193	PROmech™ LD28 Miniature Linear Positioners
194	PROmech™ Options & Accessories

Miniature Positioning Stages Common Features

- Small size; high acceleration, velocity, resolution, repeatability and accuracy
- Miniature profile stages as small as 25 X 80 mm
- Travel lengths to 750 mm
- Acceleration to 5 g; velocity to 3 m/sec
- Internal cable management or non-moving cables
- Square rail or cross roller bearing systems
- Compatible mounting for multi-axis systems
- Cleanroom prep, low ESD coating and vacuum prep options
- Submicron precision options
- Thorough testing and certification

MX80L Linear Motor Driven Stages

Page 154-161

Parker's MX80L Miniature Linear Motor Stage is the smallest linear servo motor driven positioner in the industry. Loaded with high performance features, the MX80L is ideal for rapid linear translation and precise positioning of lighter loads in small work envelopes.

Precision Grade & Standard Grade



MX80L stages provide high-precision positioning and linear motor dynamics for positioning light loads within a small workspace. They offer exceptional straightness and flatness of travel, and can position repeatedly within ± 0.4 microns with encoder resolutions down to 10 nanometers.

MX80S Ballscrew & Leadscrew Driven Stages

Page 162-167



MX80S ballscrew driven motorized stages (left) offer high performance 100% duty operation with higher thrust (128 N) and velocities up to 100 mm/second. Featuring a PTFE coated leadscrew drive assembly (right), the MX80S provides cost-effective linear translation at velocities to 200 mm/second.

MX80M Free Travel and Micrometer Driven Stages

Page 168-171



MX80M stages have a precision micrometer drive assembly for manually controlled point to point positioning along a linear path.

LX80L Long Travel Tables

Page 172-179



For longer travel lengths, the LX80L Series offers linear motor dynamics and travels up to 750 mm while maintaining a very small profile.

PROmech LP28 & LD28 Miniature Linear Positioners

Page 180-194



Designed for OEMs needing simple positioning solutions for instrument and light industrial applications, the PROmech family of positioners offers a complete positioning solution at a price OEMs can afford to design into their equipment. The LP 28 provides travels from 5 mm to 500 mm; the LD28 provides travels from 5 mm to 300 mm. Both products feature an anti-backlash nut for excellent positioning.

Miniature Positioners

Multi-Axis System Capabilities

The direct mounting compatibility of miniature stages enables a large variety of 2- or 3-axis combinations to be configured with ease. When optioned with Parker's ViX Intelligent Servo Drives, 2- or 3-axis stages are transformed into complete plug & play systems offering easy hookup and direct operation from a PC via the RS232 interface. All necessary motor-drive setup, and testing are completed at the factory prior to shipping. For standard multi-axis configurations, please go to www.parkermotion.com

Custom Solutions

Parker's years of experience of building both standard and custom positioning systems uniquely enables us to customize MX80 systems to your exact requirements. We are able to add custom brackets, counterbalances, surface finishes, fixtures, etc. to solve your specific application. Please call to discuss your requirements.



XYZ with Special Orthogonality



XYZ with Pneumatic Counterbalance



Vacuum Prepared XY



XYZ System with elevator table

MX80L Linear Servo Motor Driven Stages

Features

- Miniature size
- 5 g acceleration
- Fast settling
- Submicron precision
- High velocity (2 m/sec.)
- Multi-axis platform

Attributes

- Low profile miniature size - (25 mm high X 80 mm wide)
- Linear servo motor drive
- Six linear encoder resolutions (0.01 μm to 5.0 μm)
- 25, 50, 100, 150 and 200 mm travels
- Cross Roller bearing (zero cage creep design)
- Precision or standard grade
- Cleanroom and low ESD options
- Fully adjustable home and limit sensors
- Dowel holes for repeatable mounting of payload
- Master reference surface to travel path
- "Plug-in" intelligent drive
- Pneumatic z-axis counterbalance
- No moving cables



Miniaturization of fiber optics, photonics, electronics and biomedical processes has driven the need for smaller and more efficient positioners. Parker's MX80 miniature stage, the smallest linear servomotor driven positioner in the industry, is loaded with high-performance features for both rapid linear translation and precise positioning of lighter loads in small work envelopes. Designed for today's 24/7 production demands, the MX80 has redefined "high-throughput automation" in the world of miniature positioners.

Cross Roller Bearings
provide high stiffness and extremely smooth linear translation. A rack and pinion anti-cage creep design within the bearing races prevents cage creep even at 5g acceleration, or with cantilevered loads.

Linear Servo Motor
features a patent pending ironcore design that provides high thrust density for linear acceleration to 5g's and velocities to 2 meters/second. The non-contact design offers long life and clean operation.

Master Reference Surface
is a feature unique to the MX80 that enables customers to align their process to the actual travel path within microns.

Optical Linear Encoders
are available in six standard resolutions (10 nm, 20 nm, 0.1 μm , 0.5 μm , 1.0 μm , 5.0 mm) and is fully integrated within the body of the stage. The non-contact design offers long life and clean operation.

Home/Limit Sensors
are magnetic sensors completely housed within the body of the stage, and fully adjustable over the entire travel range.



High Performance in a Small Package

While the MX80 is small in size, it is large on performance and reliability. All key components are “built-in” – residing within the body of the stage to provide a clean looking, reliable, unobstructed package. At the heart of the MX80 is an innovative non-contact linear servo motor (patent pending). This direct drive motor has been optimized for force, speed, and acceleration, to deliver outstanding performance and response. A high-precision non-contact linear encoder provides submicron resolution, repeatability and accuracy.

Selectable resolutions range from 10 nanometers to 5 microns. Precision ground cross roller bearing sets with a “zero cage creep” feature provide extremely smooth, precise linear translation. Digital Hall effect travel limit and home sensors are conveniently designed into the unit for easy adjustment over the entire travel of the stage. Although there are no moving cables, a meter of high-flex cabling is included and wired directly into the units. This high-flex cabling addresses cable flexing concerns associated with the second or third axis in multi-axis system.

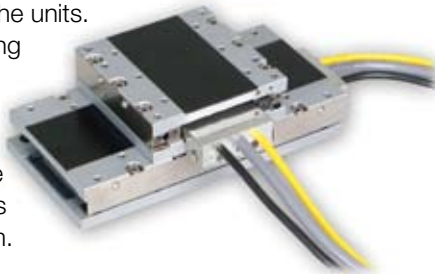

Zero Cage Creep Feature

High acceleration and smooth translation are both desired attributes in a linear-motor stage. The cross roller bearing system found in the MX80 provides extremely smooth linear translation, and with an anti-cage creep design, operates very well in high acceleration applications. This design employs a rack and pinion feature within the bearing races to eliminate bearing creep. As a result, the MX80 performs well, even at 5g acceleration.



Tooling Features

Innovative tooling features make mounting and alignment much quicker and easier.

- A hardened steel master reference surface is provided along the side of the stage to allow fixturing or other tooling elements to be precisely aligned with the actual travel path.
- Two dowel pin holes are provided on the carriage top and base for repeatable mounting of positioner or tooling.



Miniature Positioners

MX80LP Precision Series



- 4 g acceleration
- Repeatability to $\pm 0.4 \mu\text{m}$
- Straightness 4μ
- Steel body construction
- Precision ground mounting and bearing surfaces
- Electroless nickel protective finish

Precision grade models are designed for high-performance applications requiring the highest degree of positioning accuracy. They offer a steel body design with precisely ground mounting surfaces & bearing ways. They include higher resolution linear encoders, and are slope corrected, laser tested and certified for optimum precision.

MX80LS Standard Series



- 5 g acceleration
- Repeatability to $\pm 0.8 \mu\text{m}$
- Straightness 6μ
- Steel body construction
- Light weight aluminum body
- Low luster black anodize finish

Standard grade units offer a lower cost alternative for applications requiring high throughput performance with less demanding positioning requirements. They are constructed of high alloy aluminum, providing a lighter weight design which can accelerate to 5 g's.



		MX80LP Precision Grade				MX80LS Standard Grade				
Travel (mm)		25	50	100	150	25	50	100	150	200
Normal Load Capacity	kg (lb)	8 (18)	8 (18)	8 (18)	8 (18)	8 (18)	8 (18)	8 (18)	8 (18)	8 (18)
Maximum Acceleration	in/sec ²	1544	1544	1544	1158	1930	1930	1930	1544	1175
Maximum Velocity										
5.0 µm		1100	1500	2000	2000	1100	1500	2000	2000	2000
1.0 µm		1100	1500	2000	2000	1100	1500	2000	2000	2000
0.5 µm	mm/sec ²	1100	1500	1500	1500	1100	1500	1500	1500	1500
0.1 µm		300	300	300	300	300	300	300	300	300
0.02 µm		60	60	60	60	60	60	60	60	60
0.01 µm		30	30	30	30	30	30	30	30	30
Peak Force	N (lb)	12 (2.7)	12 (2.7)	24 (5.4)	24 (5.4)	12 (2.7)	12 (2.7)	24 (5.4)	24 (5.4)	24 (5.4)
Continuous Force	N (lb)	4 (0.9)	4 (0.9)	8 (1.8)	8 (1.8)	4 (0.9)	4 (0.9)	8 (1.8)	8 (1.8)	8 (1.8)
Duty Cycle	%	100	100	100	100	100	100	100	100	100
Straightness & Flatness	µm	4	4	5	6	6	6	10	12	14
Positional Accuracy*										
5.0 µm		13	14	15	15	25	30	35	35	35
1.0 µm		5	6	7	7	15	20	25	25	25
0.5 µm	µm	4	5	6	6	12	15	20	20	20
0.1 µm		3	4	5	5	12	15	20	20	20
0.02 µm		3	4	5	5	12	15	20	20	20
0.01 µm		3	4	5	5	12	15	20	20	20
Bi-directional Repeatability*										
5.0 µm		±10.0	±10.0	±10.0	±10.0	±10.0	±10.0	±10.0	±10.0	±10.0
1.0 µm		±2.0	±2.0	±2.0	±2.0	±2.0	±2.0	±2.0	±2.0	±2.0
0.5 µm	µm	±1.0	±1.0	±1.0	±1.0	±1.0	±1.0	±1.0	±1.0	±1.0
0.1 µm		±0.5	±0.5	±0.5	±0.5	±0.5	±0.5	±0.5	±0.5	±0.7
0.02 µm		±0.4	±0.4	±0.4	±0.4	±0.4	±0.4	±0.4	±0.4	±0.5
0.01 µm		±0.4	±0.4	±0.4	±0.4	±0.4	±0.4	±0.4	±0.4	±0.5
Unit Mass	g	590	590	1027	1345	475	475	875	1125	1370
Carriage Mass (unloaded)	g	282	282	509	676	213	213	405	537	695

* Notes:

(1) Measured at the carriage center, 35 mm above the mounting surface @ 20 C with no load. Unit bolted to granite surface, flat to within 1 micron/300 mm.

(2) Total accuracy and bi-directional repeatability over full travel (peak to peak).

(3) Precision grade with slope correction value provided. Consult factory if better accuracy is required.

(1) Total accuracy and bi-directional repeatability over full travel (peak to peak).



Force - Speed

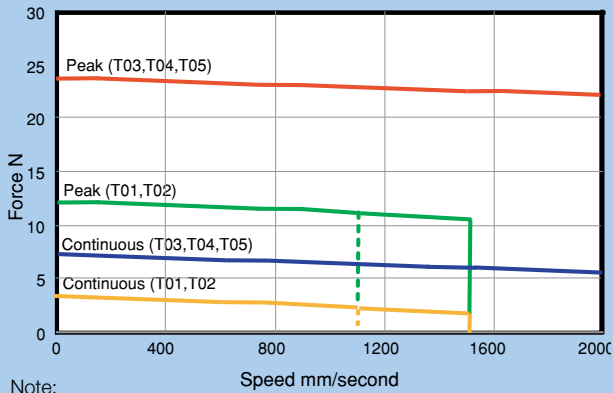

Note:
 T01(25 mm travel) is limited to a maximum speed of 1100 mm/sec.
 T02 (50 mm) is limited to 1500 (due to limited travel).

Life - Load (Normal Load)

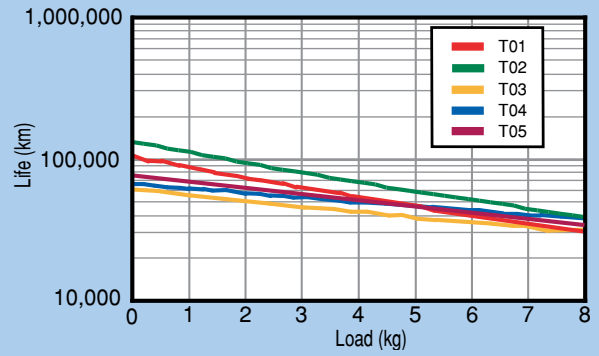

Distance vs Time

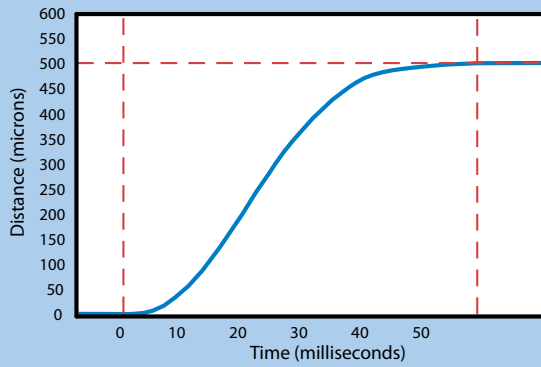

Note: 1 Kg payload, 500 micron move:
 Move and settle to within 1 micron in 47 milliseconds.

Velocity Ripple

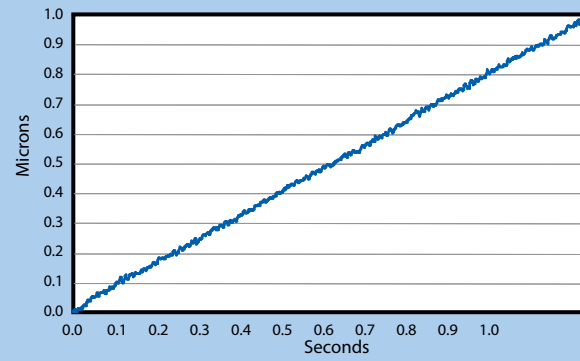

Note: Test were performed using a model MX80LT04D13E8 with a 20 nanometer linear encoder

Miniature Positioners

Simple Configuration Digital Drive Options

All digital drives ordered in the MX80 part number configuration come set up with a motor file including electrical parameters to set continuous and peak currents, current loop compensation values, and default gain settings.



Users will have the ability to override these parameters for special application requirements.

Tuning is easy and intuitive for users and is available via a variety of methods. The motor and loading information must be known by the drive to determine the baseline tuning gains. These are simple parameter entries the user can complete with the help of standard Parker supplied front-end software tools. Seamless integration of drives and controls ensures performance matched functionality of the completed motion system.

ViX Intelligent Servo & Microstepping Drives/Controllers

The ViX servo and microstepping drives are the perfect drive solution to be paired with the MX80 family. These drives use advanced field oriented digital control technology to enhance dynamic performance and improve efficiency. In addition to servo and microstepping versions, the ViX family is offered with different levels of control.

ViX Servo Drive

Order Codes: A20 A21 A22

ViX Servo Drive/Controller

Order Codes: A25

XL-PSU Power Supply Module Accessory

The Parker XL-PSU power supply offers a convenient way of powering a ViX series servo drive.



“Plug & Play” Cable Options

Order Codes: CM04 CM05 CM06 CM07

“User convenience” is high on the list of cable attributes found in the MX80. The high-flex cabling and connectors are reliable, durable and offer easy hook-up for “plug and run” installation.



- High-flex cables
- Plug-in compatibility with ViX drive
- CE compliant connectors and shielding
- CE compliant ferrite beads
- Color coded jackets and labeling
- Connectors simplify installation

Encoder Options

Order Codes: E2 E3 E4 E8 E9

A non-contact linear optical encoder provides a quadrature output and offers resolution ranging from 10 nanometer to 5 micron. On the MX80L, the encoder is internal to the stage body. There is no increase to the footprint of the unit and no additional external cabling is required.

Home and Limit Sensor Options

Order Codes: H1 H2 H3 L1 L2 L3

Magnetic home and limit sensors are completely housed within the body of the stage. An innovative design adds functionality without sacrificing geometry. Sensor triggers can be easily adjusted over the travel. The output format is an open collector type capable of sinking up to 50 mA, and be set as N.O. or N.C.

For complete details on drive product features and specifications, please refer to the “Drives & Controllers” section of this catalog.



Cleanroom Option

Order Codes: R2 R20

Both precision and standard grade products can be prepared for cleanroom compatibility. Preparation involves material changes, element modification and cleanroom compatible lubricants. MX80L and MX80S stages with this option are class 10 cleanroom compatible. When applying an XY or XYZ combination in a cleanroom environment, moving wires need to be considered – please consult a Parker application engineer.



Low ESD Coating Option

Order Codes: R10 R20

An optional low ESD electroless nickel or Armoloy coating is offered for improved electrically conductivity, providing a low resistance to ground path for electric discharge.



Environmental Protection Option

Both precision and standard grade units have a hard coat protective finish. The precision units have a hard coat (Rc 78) satin chrome finish, and the standard units have a low luster black anodized finish.

System Orthogonality Option

Order Codes: S2 S3 S4 S5 S6

In any multi-axis positioning system, the perpendicular alignment of the axes must be clearly specified. “Degree of orthogonality” defines the perpendicular alignment of axis one to another. The MX80 offers two choices for orthogonality. As standard, perpendicularity is held to within 60 arc seconds. For more exacting applications the MX80 can be optioned for 15 arc seconds orthogonality.

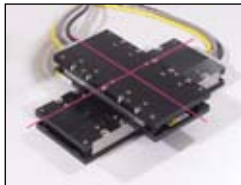

Z-axis Counterbalance Option

Order Codes: X2

A pneumatic Z-axis counterbalance is offered to prevent a sudden load drop if power to the motor is interrupted. A controlled vertical force is applied to the stage top to negate the effect of gravity and achieve equilibrium. A precisely regulated clean air supply of 0 to 60 psi is required for operation. (See Pneumatic Accessory Package)



Pneumatic Accessory Package

This accessory is offered for use with the pneumatic counterbalance option. It consists of a pre-filter, a pressure regulator, a coalescing filter, and a precision regulator to precisely regulate air pressure and remove oil, water or debris down to 3 microns.



Part Number: 002-2236-01

Z-Axis Bracket Accessory

Lightweight aluminum Z-brackets are available for easy construction of vertical axis combinations.

Standard Model Part Numbers:

25 & 50 mm: 002-2238-01
100 & 150mm: 002-2240-01

Low ESD Model Part Numbers:

5 & 50 mm: 002-2239-01
100 & 150 mm: 002-2241-01

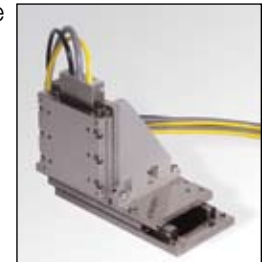

Miniature Positioners

Dimensions (mm)

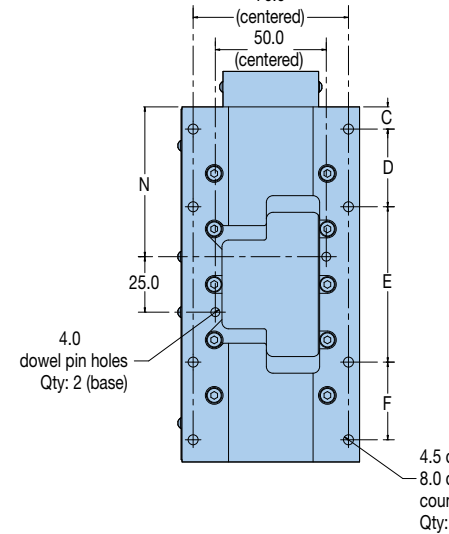
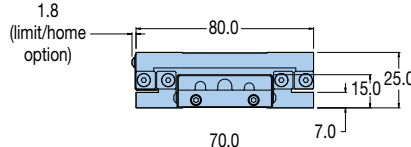
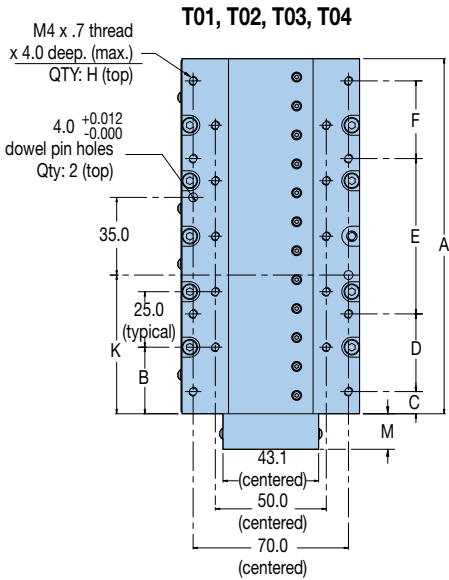

4.5 drill thru
8.0 dia. x 5.0 deep
counterbore (far side)
Qty: J (base)

4.0 $+0.012$
 -0.000
dowel pin holes
Qty: 2 (base)

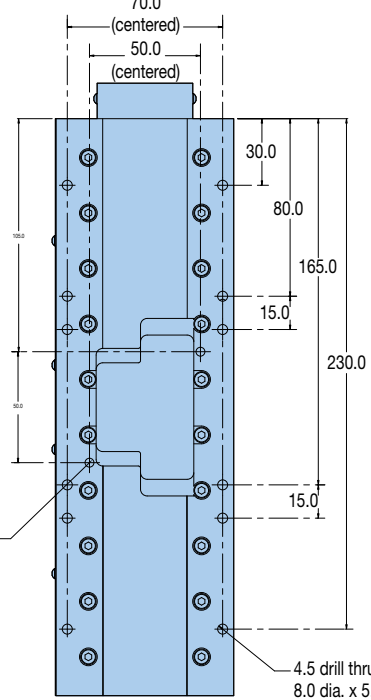
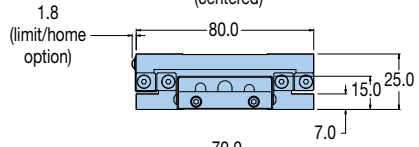
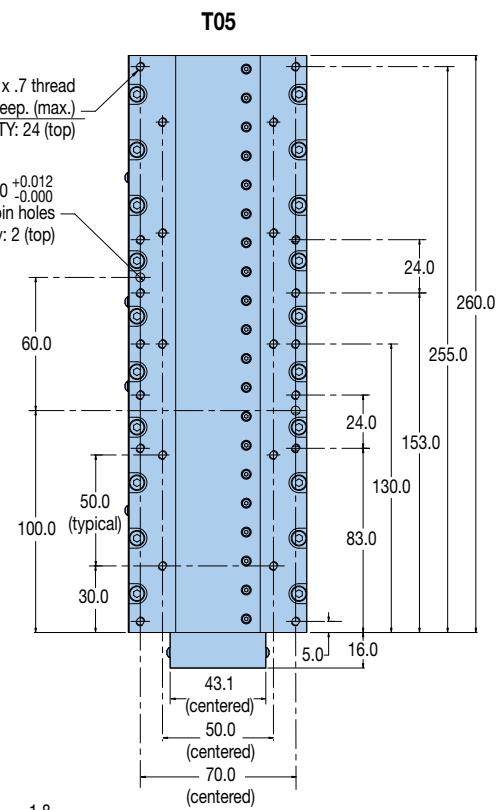

4.5 drill thru
8.0 dia. x 5.0 deep
counterbore (far side)
Qty: 12 (base)

Z-axis

Travel	Dim Z
25	166
50	166
100	251
150	326
200	-

Pneumatic Vertical Axis Counter Balance

Travel	Dim X
25	156.6
50	156.6
100	230.6
150	310.6
200	-

Dimensions (mm)											
Travel	A	B	C	D	E	F	H	J	K	M	N
25	80	15	5	70	-	-	10	4	22.5	22	27.5
50	80	15	5	70	-	-	10	4	22.5	22	27.5
100	160	30	10	35	70	35	18	8	62.5	16	67.5
150	210	30	5	65	70	65	22	8	87.5	16	92.5



Fill in an order code from each of the numbered fields to create a complete model order code.

① ② ③ ④ ⑤ ⑥ ⑦ ⑧ ⑨ ⑩ ⑪ ⑫ ⑬ ⑭

Order Example: MX80L T02 M P -D11 H3 L2 CM05 Z3 E8 R1 A25 X1 S1

① **Series**
MX80L

② **Travel – mm**
T01 25
T02 50
T03 100
T04 150
T05 200

③ **Mounting**
M Metric

④ **Grade**
S Standard
P Precision (not available with T05 Travel option)

⑤ **Drive Type**
D1 Free Travel (No Motor)
D11 4 Pole (25 & 50 mm travel only)
D13 8 Pole (100, 150 & 200 mm travel only)

⑥ **Home Sensor**
H1 None-Free Travel (only)
H2 N.C. Current Sinking
H3 N.O. Current Sinking

⑦ **Limit Sensor**
L1 None-Free Travel (only)
L2 N.C. Current Sinking
L3 N.O. Current Sinking

⑧ **Cable Options**
CM03 No Cables – Free Travel
CM04 High-Flex Cables w/ViX Connector (1 meter)
CM05 High-Flex Cables w/ViX Connector (3 meter)
CM06 High-Flex Cables w/ViX Connector, no limit/home cable (1 meter)
CM07 High-Flex Cables w/ViX Connector, no limit/home cable (3 meter)

⑨ **Z Channel Location**
Z1 None
Z3 Center Position

⑩ **Digital Linear Encoder Option**
E1 None
E2 1.0 µm Resolution
E3 0.5 µm Resolution
E4 0.1 µm Resolution
E8 0.02 µm Resolution (20 nanometer)
E9 0.01 µm Resolution (10 nanometer)

⑪ **Environmental**
R1 Standard Finish (black anodized)
R2 Cleanroom Prep
R10 Low ESD Finish
R20 Low ESD Finish & Cleanroom Prep

⑫ **Digital Drive**
A1 No Drive
A20 ViX250-AH (force mode)
A21 ViX250-AH (velocity mode)
A22 ViX250-AH (step/direction mode)
A25 ViX250-IH Drive/Controller

⑬ **Other Options**
X1 None
X2 Z-axis Pneumatic Counter Balance*
* Not available with T05 Travel.

⑭ **Axis Designator**
S1 None (single-axis)
S2 X-axis base unit (cables @ 12 o'clock)
S3 Y-axis 60 arc-sec (cables @ 3 o'clock)
S4 Y-axis 60 arc-sec (cables @ 9 o'clock)
S5 Y-axis 15 arc-sec (cables @ 3 o'clock)
S6 Y-axis 15 arc-sec (cables @ 9 o'clock)

Miniature Positioners

MX80S Ballscrew and Leadscrew Driven Stages

Features

- Miniature Size - Low Profile (35 mm high X 80 mm wide)
- Normal or cleanroom environments
- 25, 50, 100, 150 mm travels
- Multi-axis platform
- Ballscrew or leadscrew drive options

Attributes

- Low profile miniature size
- Up to 123 N axial thrust
- 2g acceleration
- Cross roller bearing (zero cage creep option)
- Stepper or servo motor drive
- Digital limit/home system
- Optional linear encoder
- Cleanroom prep. option
- Low ESD option for electrically sensitive applications

The MX80S miniature positioner is the screw driven member of Parker's MX80 family. Like its counterparts, the MX80L linear motor driven stage and MX80M manual stage, the MX80S is designed for applications requiring reliable linear positioning in space restricted applications. It is the complementary product that bridges the product spectrum between the high dynamic linear motor performance of the MX80L, and the manual precision of the MX80M. The MX80S can be supplied with a high-efficiency leadscrew drive capable of reaching 200 mm per second velocity, or a precision ground ballscrew drive offering axial thrust to 123 N.

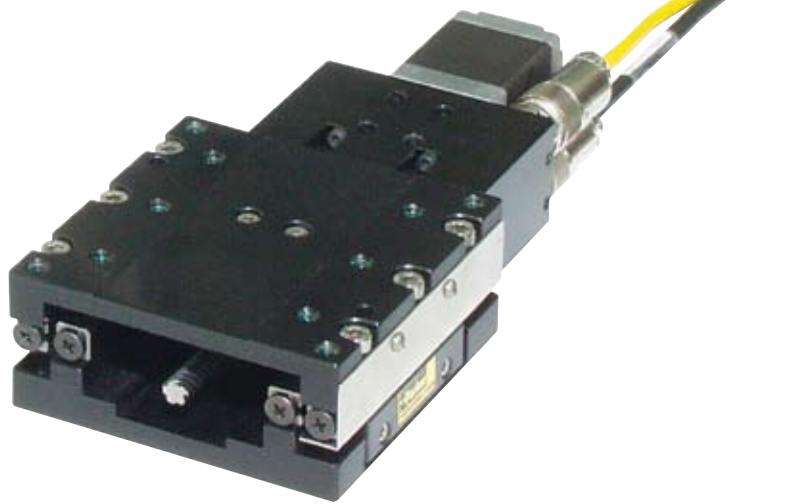

The leadscrew drive employs a PTFE coated leadscrew with a preloaded nut to produce extremely smooth linear translation. A choice of three leads provides improved opportunity for matching desired velocity/resolution requirements.



Leadscrew drive



Ballscrew drive

The 2.0 mm lead ballscrew stage offers high performance 24/7 operation with a thrust load capacity of 123 N (28 lb) and velocity to 100 mm/second at 100% duty cycle.

Cross Roller Bearings
provide high stiffness and extremely smooth linear translation. A rack and pinion anti-cage creep design within the bearing races prevents cage creep even at 5 g acceleration, or with cantilevered loads.

Ballscrew or leadscrew drive
The 2.0 mm lead ballscrew driven stage offers high performance 24/7 operation with a thrust load capacity of 123 N (28 lb.) and velocity to 100 mm/second at 100% duty cycle. Leadscrew driven stages are available with 1 mm, 2 mm, or 10 mm leads. The PTFE coated leadscrew provides extremely smooth linear translation at velocities up to 200 mm/second.

Master Reference Surface
is a feature unique to the MX80 that enables customers to align their process to the actual travel path within microns.

Home/Limit Sensors
are magnetic sensors completely housed within the body of the stage, and fully adjustable over the entire travel range.



		MX80S Leadscrew Drive				MX80S Ballscrew Drive			
Travel (mm)		25	50	100	150	25	50	100	150
Normal Load Capacity	kg (lb)	8 (18)	8 (18)	8 (18)	8 (18)	8 (18)	8 (18)	8 (18)	8 (18)
Thrust Load Capacity	N (lb)	44 (10)	44 (10)	44 (10)	44 (10)	123 (28)	123 (28)	123 (28)	123 (28)
Maximum Velocity									
1.0 mm lead	mm/sec	20	20	20	20	—	—	—	—
2.0 mm lead		40	40	40	40	100	100	100	100
10.0 mm lead		200	200	200	200	—	—	—	—
Breakaway Torque	Nm	0.021	0.021	0.021	0.021	0.050	0.050	0.050	0.050
Running Torque									
1.0 mm lead	Nm	0.028	0.028	0.035	0.035	—	—	—	—
2.0 mm lead		0.028	0.028	0.035	0.035	0.085	0.085	0.085	0.085
10.0 mm lead		0.021	0.021	0.021	0.028	—	—	—	—
Duty Cycle	%	50	50	50	50	100	100	100	100
Straightness & Flatness*	µm	8	12	16	20	8	12	16	20
Positional Accuracy*									
1.0 mm lead	µm	30	45	75	100	—	—	—	—
2.0 mm lead		30	45	75	100	10	15	18	20
10.0 mm lead		35	50	80	105	—	—	—	—
Bi-directional Repeatability*									
1.0 mm lead	µm	±5.0	±5.0	±5.0	±5.0	—	—	—	—
2.0 mm lead		±5.0	±5.0	±5.0	±5.0	±1.5	±1.5	±1.5	±1.5
10.0 mm lead		±10.0	±10.0	±10.0	±10.0	—	—	—	—
Inertia (without motor & coupling)									
1.0 mm lead	10 ⁻⁷ kg-m ²	1.47	1.47	2.42	3.06	—	—	—	—
2.0 mm lead		1.62	1.62	2.68	3.42	4.19	4.19	6.08	7.68
10.0 mm lead		6.34	6.34	11.30	14.90	—	—	—	—
Screw Speed (max)	rps	20	20	20	20	50	50	50	50
Leadscrew Efficiency									
1.0 mm lead	%	40	40	40	40	—	—	—	—
2.0 mm lead		59	59	59	59	90	90	90	90
10.0 mm lead		78	78	78	78	—	—	—	—
Screw Diameter	mm	6.35	6.35	6.35	6.35	8.00	8.00	8.00	8.00
Bearing Coefficient of Friction		0.003	0.003	0.003	0.003	0.003	0.003	0.003	0.003
Unit Mass									
Table only	g	597	597	1003	1268	694	694	1114	1392
With 2-stack stepper		748	748	1154	1419	845	845	1265	1513
Carriage Mass (unloaded)	g	194	194	353	471	291	291	464	595

* Notes:

(1) Measured at the carriage center, 35 mm above the mounting surface @ 20 C with no load. Unit bolted to granite surface, flat to within 1 micron/300 mm.
 (2) Total accuracy and bi-directional repeatability over full travel (peak to peak).

(1) Measured at the carriage center, 35 mm above the mounting surface @ 20 C with no load. Unit bolted to granite surface, flat to within 1 micron/300 mm.
 (2) Total accuracy and bi-directional repeatability over full travel (peak to peak).
 (3) Repeatability valid with M21 servo motor.

Miniature Positioners

Simple Configuration Digital Drive Options

All digital drives ordered in the MX80 part number configuration come set up with a motor file including electrical parameters to set continuous and peak currents, current loop compensation values, and default gain settings. Users will have the ability to override these parameters for special application requirements.



Tuning is easy and intuitive for users and is available via a variety of methods. The motor and loading information must be known by the drive to determine the baseline tuning gains. These are simple parameter entries the user can complete with the help of standard Parker supplied front-end software tools. Seamless integration of drives and controls ensures performance matched functionality of the completed motion system.

ViX Intelligent Servo & Microstepping Drives/Controllers

The ViX servo and microstepping drives are the perfect drive solution to be paired with the MX80 family. These drives use advanced field oriented digital control technology to enhance dynamic performance and improve efficiency. In addition to servo and microstepping versions, the ViX family is offered with different levels of control.

ViX Servo Drive

Order Codes: A10 A11 A12

ViX Servo Drive/Controller

Order Codes: A15

ViX Microstep Drive/Controller

Order Codes: A62

E-AC and E-DC Microstepping Drive

Order Codes: A31

XL-PSU Power Supply Module Accessory

The Parker XL-PSU power supply offers a convenient way of powering a ViX series servo drive.



For complete details on drive product features and specifications, please refer to the “Drives & Controllers” section of this catalog.

“Plug & Play” Cable Options

Order Codes: CM02 CM03 CM04 CM05 CM06 CM07 CM08 CM09 CM10 CM11 CM12 CM13 CM15 CM17

“User convenience” is high on the list of cable attributes found in the MX80. The high-flex cabling and connectors are reliable, durable and offer easy hook-up for “plug and run” installation.



- High-flex cables
- Plug-in compatibility with ViX drive
- CE compliant connectors and shielding
- CE compliant ferrite beads
- Color coded jackets and labeling
- Connectors simplify installation

Encoder Options

Order Codes: E2 E3 E4 E5 E7

A non-contact linear optical encoder provides a quadrature output and offers resolution ranging from 10 nanometer to 5 micron. On the MX80L, the encoder is internal to the stage body. There is no increase to the footprint of the unit and no additional external cabling is required.

Home and Limit Sensor Options

Order Codes: H2L2 H2L3 H3L2 H3L3

Magnetic home and limit sensors are completely housed within the body of the stage. An innovative design adds functionality without sacrificing geometry. Sensor triggers can be easily adjusted over the travel. The output format is an open collector type capable of sinking up to 50 mA, and be set as N.O. or N.C.



Cleanroom Option

Order Codes: R2 R20

Both precision and standard grade products can be prepared for cleanroom compatibility. Preparation involves material changes, element modification and cleanroom compatible lubricants. MX80L and MX80S stages with this option are class 10 cleanroom compatible. When applying an XY or XYZ combination in a cleanroom environment, moving wires need to be considered – please consult a Parker application engineer.



Z-Axis Bracket Accessory

Lightweight aluminum Z-brackets are available for easy construction of vertical axis combinations.

Standard Model Part Numbers:

25 & 50 mm: 002-2238-01
100 & 150 mm: 002-2240-01

Low ESD Model Part Numbers:

5 & 50 mm: 002-2239-01
100 & 150 mm: 002-2241-01



Low ESD Coating Option

Order Codes: R10 R20

An optional low ESD electroless nickel or Armoloy coating is offered for improved electrical conductivity, providing a low resistance to ground path for electric discharge.



Environmental Protection Option

Both precision and standard grade units have a hard coat protective finish. The precision units have a hard coat (Rc 78) satin chrome finish, and the standard units have a low luster black anodized finish.

System Orthogonality Option

Order Codes: S2 S3 S4 S5 S6

In any multi-axis positioning system, the perpendicular alignment of the axes must be clearly specified. “Degree of orthogonality” defines the perpendicular alignment of axis one to another. The MX80s offer two choices for orthogonality. As standard, perpendicularity is held to within 60 arc seconds. For more exacting applications the MX80 can be optioned for 15 arc seconds orthogonality.

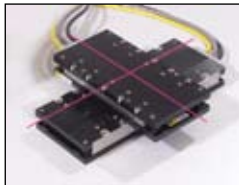

Miniature Positioners

Dimensions (mm)

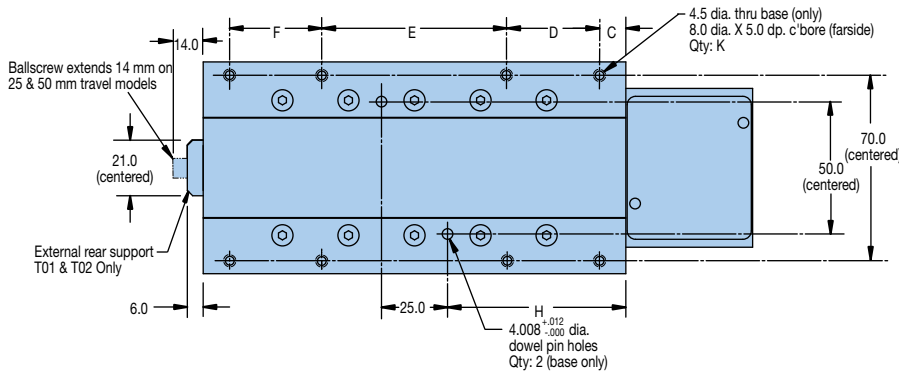
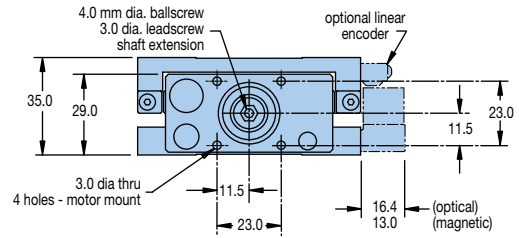
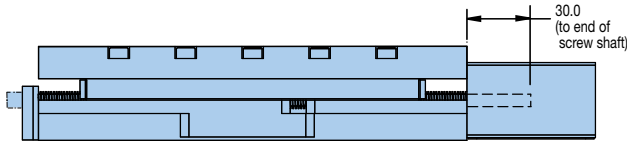
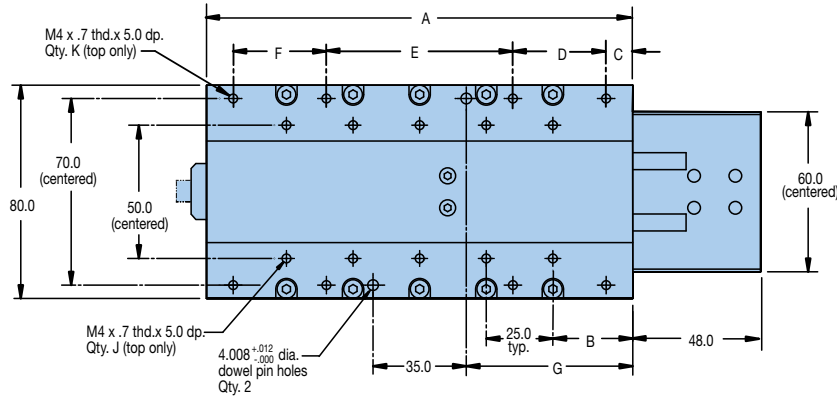

Dimensions (mm)

Travel	A	B	C	D	E	F	G	H	J	K
25	80	15	5	70	—	—	22.5	27.5	6	4
50	80	15	5	70	—	—	22.5	27.5	6	4
100	160	30	10	35	70	35	62.5	67.5	10	8
150	210	30	5	65	70	65	87.5	92.5	14	8

Mounting

Servo Motor

Stepper Motor

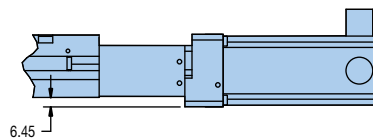
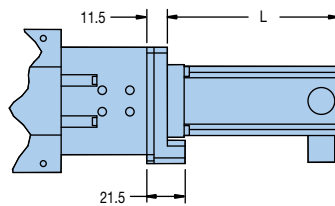
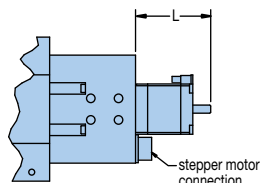

Model	# Stack	NEMA	Dimension L (mm)
Stepper	1		42.0
	2	11	50.0
	3		61.5
Servo	1	16	83.6



Fill in an order code from each of the numbered fields to create a complete model order code.

① ② ③ ④ ⑤ ⑥ ⑦ ⑧ ⑨ ⑩ ⑪ ⑫ ⑬ ⑭ ⑮

Order Example: MX80S T04 M P K - D1 M1 H3L3 CM12 E1 Z1 R1 A11 X1 S1

① **Series**
MX80S

② **Travel – mm**
T01 25
T02 50
T03 100
T04 150

③ **Mounting**
M Metric

④ **Grade**
S Standard
P Precision*

* Must order E3 or E4 Digital Option to meet catalog specification.

⑤ **Bearing Type**
J Standard Cross Roller
K ACS Cross Roller

⑥ **Drive Type**
D1 1 mm Leadscrew ⁽¹⁾
D2 2 mm Leadscrew ⁽¹⁾
D3 10 mm Leadscrew ^(1,3)
D6 2 mm Ballscrew ^(2,3)
(1) Standard grade only (2) Precision grade only
(3) Not available with 1- or 2-stack stepper motor.

⑦ **Motor**
M0 No motor, flange, coupling
M1 NEMA 16 flange, no motor, coupling
M14 Stepper, 1 stack, NEMA 11
M15 Stepper, 2 stack, NEMA 11
M16 Stepper, 3 stack, NEMA 11
M21 Servo, 1 stack, NEMA 16

⑧ **Home/Limit Switch***
H1L1 None
H2L2 N.C. Home/N.C. Limit
H2L3 N.C. Home/N.O. Limit
H3L2 N.O. Home/N.C. Limit
H3L3 N.O. Home/N.O. Limit
*NC = Normally Closed; NO = Normally Open

⑨ **Cable Options (High-flex)**
CM01 None
CM02 Limits (only) w/Flying Leads (1 meter)
CM03 Limits (only) w/Flying Leads (3 meter)
CM04 Limits (only) w/ViX Connector (1 meter)
CM05 Limits (only) w/ViX Connector (3 meter)
CM06 Stepper Motor & Limits w/ViX Connector (1 meter)
CM07 Stepper Motor & Limits w/ViX Connector (3 meter)
CM08 Stepper Motor (no Limits) w/ViX Connector (1 meter)
CM09 Stepper Motor (no Limits) w/ViX Connector (3 meter)
CM10 Stepper Motor (E Drive) & Limits (1 meter)
CM11 Stepper Motor (E Drive) & Limits (3 meter)
CM12 Stepper Motor (E Drive) no Limits (1 meter)
CM13 Stepper Motor (E Drive) no Limits (3 meter)
CM15 Servo Motor, Encoder & Limits w/ViX Connector (3 m)
CM17 Servo Motor, Encoder (no Limits) w/ViX Connector (3 m)

⑩ **Digital Option**
E1 None
E2 1.0 µm Resolution
E3 0.5 µm Resolution
E4 0.1 µm Resolution
E5 5.0 µm Resolution
E7 Sine Output

⑪ **Z Channel Location**
Z1 None
Z3 Center Position

⑫ **Environmental**
R1 Standard Finish (black anodized)
R2 Cleanroom Prep
R10 Low ESD Finish
R20 Low ESD Finish & Cleanroom Prep

⑬ **Digital Drive**
A1 No Drive
A10 ViX250-AE Servo (torque mode)
A11 ViX250-AE Servo (velocity mode)
A12 ViX250-AE Servo (step/direction mode)
A15 ViX250-IE Servo Drive/Controller
A31 E-DC Stepper Drive
A62 ViX250-IM Stepper Drive/Controller

⑭ **Axis Designator**
S1 None (single-axis)
S2 X-axis base unit (cables @ 12 o'clock)
S3 Y-axis 60 arc-sec (cables @ 3 o'clock)
S4 Y-axis 60 arc-sec (cables @ 9 o'clock)
S5 Y-axis 15 arc-sec (cables @ 3 o'clock)
S6 Y-axis 15 arc-sec (cables @ 9 o'clock)

⑮ **Required Designator**
X1

Miniature
Positioners

MX80M Free Travel and Micrometer Driven Stages

Features

- Precision cross roller bearings
- Optional cleanroom prep.
- Optional low ESD coating
- Dowel holes in top & base
- Interchangeable mounting with motorized MX80 models
- Positive position lock

The MX80M stages are offered as free travel or micrometer driven units with 25 mm or 50 mm travel. They include innovative tooling features to make mounting and precision alignment quicker and easier. A hardened steel master reference surface is provided along the side of the stage to allow fixturing or other tooling elements to be precisely aligned with the actual travel path. Dowel pin holes are provided on the carriage top for repeatable mounting or tooling. Also available are custom features such as a steel body design, vacuum prepped units, and anti cage creep bearings for high-dynamic applications up to 150 mm travel.





		MX80M Free Travel		MX80LM Micrometer Driven	
Travel (mm)		25	50	25	50
Normal Load Capacity	kg (lb)	20 (44)	20 (44)	20 (44)	20 (44)
Axial Force ⁽¹⁾					
F_a	kg	—	—	4.5	4.5
F_b		—	—	0.6	1.0
Straight Line Accuracy (per 25 mm travel)	μm	2	2	2	2
Micrometer Resolution					
0.001 in		—	—	Yes	Yes
0.01 mm		—	—	Yes	Yes
Digital Micrometer					
0.00005 in		—	—	Yes	Yes
0.001 mm		—	—	Yes	Yes

⁽¹⁾ F_a (force acting against micrometer)
 F_b (force acting against spring)

Free Travel (with position lock)

Dimensions (mm)

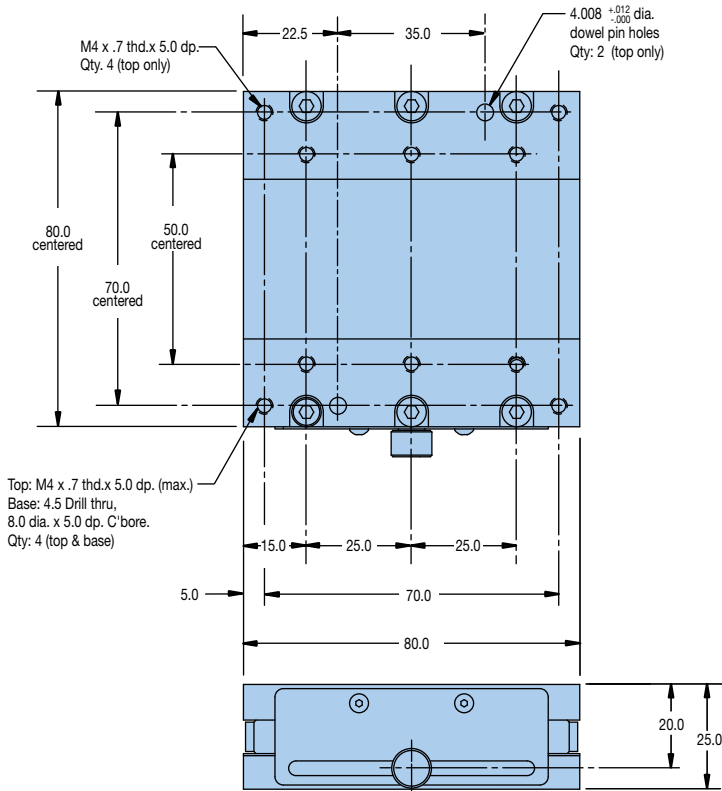

Digital Micrometer (side drive shown)

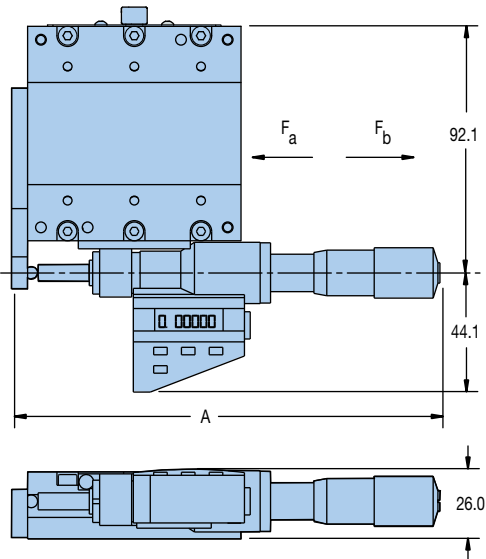

Standard Micrometer (center drive shown)

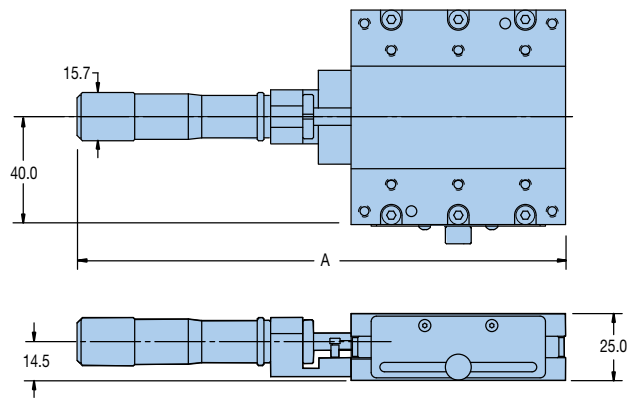

Drive Orientation	Travel	Dimension A (mm)
Center	25	225.6
	50	273.5
Side	25	160.6
	50	209.5

Drive Orientation	Travel	Dimension A (mm)
Center	25	182.2
	50	231.4
Side	25	117.2
	50	167.4



Fill in an order code from each of the numbered fields to create a complete model order code.

	①	②	③	④	⑤	⑥	⑦	⑧	⑨	
Order Example:	MX80M	T02	M	-	S	C2	D22	R1	X4	S1
① Series	MX80M									
② Travel – mm	T01	25								
	T02	50								
③ Mounting	M	Metric								
④ Grade	S	Standard								
⑤ Style	C1	Free Travel								
	C2	Center Drive								
	C3	Side Drive								
⑥ Drive Type						D1	None			
						D20	Metric Micrometer			
						D21	English Micrometer			
						D22	Digital Micrometer			
⑦ Environmental						R1	Standard Finish (black anodized)			
						R2	Cleanroom Prep			
						R10	Low ESD Finish			
						R20	Low ESD Finish & Cleanroom Prep			
⑧ Lock Options						X1	No Lock			
						X4	With Lock			
⑨ Axis Designator						S1	None (single-axis)			
						S2	X-axis base unit (micrometer @ 12 o'clock)			
						S3	Y-axis 60 arc-sec (micrometer @ 3 o'clock)			
						S4	Y-axis 60 arc-sec (micrometer @ 9 o'clock)			
						S5	Y-axis 15 arc-sec (micrometer @ 3 o'clock)			
						S6	Y-axis 15 arc-sec (micrometer @ 9 o'clock)			

Miniature Positioners

LX80L Miniature Linear Tables

Features

- Velocity to 3 m/sec
- Acceleration to 5 g's
- Encoder resolution to 0.1 micron
- Cleanroom compatible
- Easy multi-axis mounting
- Internal cable management

Miniaturization of life sciences, electronics, photonics, and fiber optic processes has driven the need for smaller and more efficient positioners.

Parker's MX80, the smallest linear servomotor driven positioner in the industry, has redefined "high-throughput automation" in the world of miniature positioners. It is loaded with high performance features for both rapid linear translation and precise positioning of smaller loads within very small work envelopes. The LX80L picks up where the MX80 leaves off, offering longer travels than the MX80 while maintaining a very small profile. Like the MX80, it is designed to meet the rigors of today's 24/7 production demands.

High Performance in a Small Package

Although it has a small profile, the LX80L is large on performance and reliability. All key components are "built-in," residing within the body of the table to provide a clean looking, reliable, unobstructed package. At the heart of the LX80L is an innovative non-contact linear servo motor (patent pending). This direct drive motor has been optimized for force, speed, and acceleration to deliver outstanding performance and response. A high-precision non-contact linear encoder provides submicron resolution, repeatability and accuracy with selectable resolutions ranging from 0.1 microns to 5 microns. Hall effect limit and home sensors are conveniently designed into the unit for easy adjustment over the entire travel of the table.

Precision square rail bearings provide load support and precise linear translation, while effectively countering the problematic effects of heat, high speeds, and high acceleration. Cable management is neatly packaged inside the unit so no moving cables are visible. From the end of the unit, "high-flex" cabling is provided for direct connection to the servo drive. This "high-flex" cabling alleviates cable flexing concerns associated with the second or third axis in multi-axis system.



Single or Double Row Bearings

Precision linear bearings support the carriage, motor, and payload. Sized to provide virtually unlimited life, the bearings provide stable and accurate linear motion while maintaining



high rigidity even under combined or fluctuating loads.

Unique in the LX80L's design are single and double linear bearing rail options. The double rail design consists of two linear rails spaced apart with a total of four bearing trucks. This version offers the best load capacity, straightness/flatness, and stability. For applications requiring minimal load capacity and precision, a single rail version is offered with a single linear rail and two bearing trucks. This version reduces cost and further reduces the width to 63 mm. The single rail version is also useful when building gantry systems where stability is achieved through use of a second axis or idler rail.

Tooling Features

Standard dowel pin locating holes facilitate repeatable mounting of a table and payloads. Two dowel holes in the LX80L base enable simple, repeatable mounting of the table into a machine.



Similarly, two dowel holes in the carriage enable simple, repeatable mounting of a fixture or payload onto the LX80L.



Home and Limit Sensors

Hall effect home and limit sensors are completely housed within the body of the motor driven table. An innovative design adds functionality without sacrificing geometry. Sensor triggers can be easily adjusted over the travel. The output format is an open collector type capable of sinking up to 50 mA.

LX80L Multi-Axis Systems

The direct mount compatibility of the LX80 and compatibility with the MX80 family enables a large variety of two and three axis systems. Possible configurations include XY systems where LX80s serve as the base axis and either an LX80 or MX80 serve as the Y axis. XZ and XYZ arrangements are possible when using MX80s as Z axes. MX80 Z-axis brackets are mount compatible with the LX80 carriage.

When optioned with Parker's ViX series drives, 2- and 3-axis systems are transformed into complete plug & run systems offering easy hookup and configuration. Intelligent ViX drives offer direct control from a PC via the RS232 interface. This solution offers a simple low cost control solution when tight coordination is not needed. For applications requiring a higher level of axis coordination, one of Parker's ACR family of controllers is an effective solution. The ACR1505 is a powerful PCI bus based motion controller capable of controlling up to 4 axes. The ACR9000 is similar but packaged as a standalone unit with RS232, USB, and Ethernet capability.

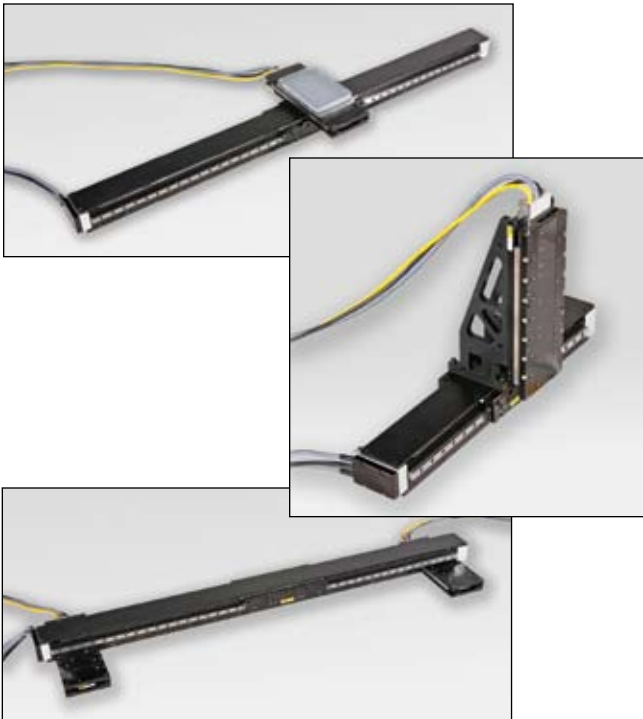

Mounting Variations

All versions of the LX80 can be mounted flat to a surface using 4 mm cap screws. The single rail version offers an additional mounting option where the table can be edge mounted. This allows further reduction of axis width to 45 mm for applications where space is very limited.



Idler Rail

For gantry or Cartesian configurations, an idler rail is available to provide greater system stability. Contact a Parker application engineer for detail on adding this to your system. For gantry or Cartesian configurations, an idler rail is available to provide greater system stability. Contact a Parker application engineer for detail on adding this to your system.



Customs and Systems

For specialized applications requiring customization, Parker design engineers can easily modify LX80L tables to suit all application specific requirements. Parker has taken the mystery, difficulty and cost out of integrating linear motor tables into high throughput precision positioning applications.

		8 Pole		16 Pole	
		Single Rail	Double Rail	Single Rail	Double Rail
Normal Load Capacity	kg (lb)	3 (6.5)	3 (6.5)	6 (13)	6 (13)
Maximum Acceleration	in/sec ²	1930	1930	1930	1930
Maximum Velocity					
Encoder Resolution:					
0.1 µm	m/sec	0.3	0.3	0.3	0.3
0.5 µm		1.5	1.5	1.5	1.5
1.0 µm		3.0	3.0	3.0	3.0
5.0 µm		3.0	3.0	3.0	3.0
Positional Repeatability					
Encoder Resolution:					
0.1 µm	µm	±2.5	±1.5	±2.5	±1.5
0.5 µm		±2.5	±1.5	±2.5	±1.5
1.0 µm		±3.5	±2.5	±3.5	±2.5
5.0 µm		±10.0	±10.0	±10.0	±10.0
Peak Force – Max	N (lb)	19 (4.3)	19 (4.3)	36 (8.1)	36 (8.1)
Continuous Force – Max	N (lb)	4.7 (1.0)	4.7 (1.0)	10 (2.2)	10 (2.2)
Moment Load – Max	Nm	0.75	1.5	0.75	3.0
Carriage Weight	g	287	388	476	648

Travel Dependent Specifications

			Single Rail				Double Rail					
Travel – mm			Positional Accuracy*– Encoder Resolution (µm)		Straightness & Flatness* µm	Weight –kg		Positional Accuracy*– Encoder Resolution (µm)		Straightness & Flatness* µm	Weight –kg	
Code	8 Pole	16 Pole	0.1; 0.5; 1.0	10.0		8 Pole	16 pole	0.1; 0.5; 1.0	10.0		8 Pole	16 pole
T02	150	80	12	22	13	1.590	1.854	8	18	9	1.396	1.586
T04	250	180	16	26	18	1.944	2.207	12	22	14	1.714	1.905
T06	350	280	20	30	23	2.300	2.563	16	26	19	2.035	2.225
T08	450	380	24	34	28	2.652	2.915	20	30	24	2.352	2.543
T010	550	480	27	37	33	3.006	3.269	23	33	29	2.671	2.861
T014	750	680	33	43	41	3.713	3.976	29	39	37	3.308	3.498

* Accuracy stated is at 20 degrees C, utilizing slope correction factor provided.

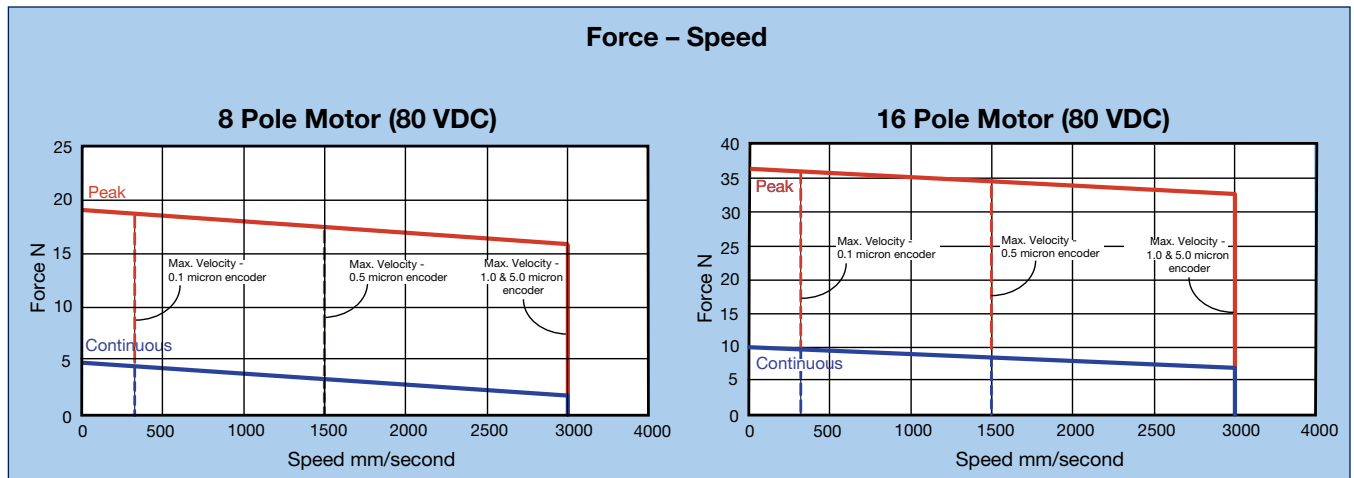



Simple Configuration Digital Drive Options

All digital drives ordered in the LX80L part number configuration come set up with a motor file including electrical parameters to set continuous and peak currents, current loop compensation values, and default gain settings. Users will have the ability to override these parameters for special application requirements.

Tuning is easy and intuitive for users and is available via a variety of methods. The motor and loading information must be known by the drive to determine the baseline tuning gains. These are simple parameter entries the user can complete with the help of standard Parker supplied front-end software tools. Seamless integration of drives and controls ensures performance matched functionality of the completed motion system.

ViX Intelligent Servo Drives/Controllers

The ViX servo and microstepping drives are the perfect drive solution to be paired with the MX80 family. These drives use advanced field oriented digital control technology to enhance dynamic performance and improve efficiency. In addition to servo and microstepping versions, the ViX family is offered with different levels of control.



ViX Servo Drive

Order Codes: A20 A21 A22

ViX Servo Drive/Controller

Order Codes: A25

ACR1505 “Acroloop” Motion Controller PCI/PC Bus Operation

The ACR1505 is Parker’s PCI Bus performance leader. The ACR1505 is a half-slot PCI card capable of operating four axes of servo or stepper motion control with four encoder inputs at up to 30 MHz (post-quadrature).



XL-PSU Power Supply Module Accessory

The Parker XL-PSU power supply offers a convenient way of powering a ViX series servo drive.



Miniature Positioners

For complete details on drive product features and specifications, please refer to the “Drives & Electronics” section of this catalog.

Cleanroom Option

Order Codes: CM03 CM04 CM05

LX80L tables can be prepared for cleanroom compatibility. Preparation involves material changes, element modification and cleanroom compatible lubricants. The LX80L with this option is class 100 cleanroom compatible. When applying an XY or XYZ combination in a cleanroom environment, moving wires need to be considered – please consult a Parker application engineer.



Encoder Options

Order Codes: E2 E3 E4 E5 E7

A non-contact linear optical encoder provides a quadrature output and offers resolution ranging from 0.1 micron to 5 micron . On the LX80L, the encoder is internal to the table body. There is no increase to the footprint of the unit and no additional external cabling is required.



Orthogonality

Order Codes: S2 S3 S4 S5 S6

In any multi-axis positioning system, the perpendicular alignment of the axes must be clearly specified. “Degree of orthogonality” defines the perpendicular alignment of axis one to another. The LX80L is offered with two choices for orthogonality. As standard, perpendicularity is held to within 60 arc seconds. For more exacting applications, the LX80L can be optioned for 15 arc seconds orthogonality.

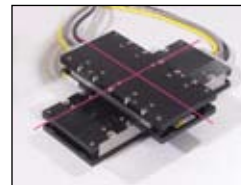

Z-Axis Bracket Accessories

Lightweight aluminum Z-brackets are available for easy construction of vertical axis combinations. These include brackets for mounting both the MX80L and MX80S tables as verticals. Contact Factory for ordering information.





Cable Management

“Plug & Play” Cable Options

Order Codes: CM03 CM04 CM05

“User friendly” and “robust” were the goals of the cabling design. All cables are high-flex for durability and are fully shielded. The cables are labeled for quick identification and have connectors at critical locations to simplify use. The drive end terminations are ViX series servo drive compatible and have CE compliant connectors including a ferrite bead to improve EMI immunity.



Internal Cable Management Accessories

The LX80’s pre-engineered internal cable management offers several benefits. It preserves the LX80’s narrow footprint by not requiring additional space for cable management. It allows the table to be mounted in any orientation without a need to re-engineer the cable management. The innovative design is field serviceable and can be maintained without a trip back to the factory. It is designed for and fully tested to last over 20 million cycles. And best of all, it is already done for you!



Internal cable management

Multi-Axis Cable Management Accessories

When building multi-axis systems, flexible cable management for the moving axes should be considered. Parker offers pre-engineered cable management for MX80s and LX80s used as the Y-axis. Contact Parker when putting multi-axis systems together to take advantage of these pre-engineered solutions.



Multi-axis cable management

Cable Options Accessories

From the end of the LX80L, high-flex extension cables are included for connection to the servo drive and control. They are offered in 1 m and 3m lengths and are connectorized at both ends for easy installation or removal. The servo drive end is connectorized for Parker’s ViX series servo drives.



Convenient connectors for ViX drives

The extension cables egress from the table at a right angle to minimize the overall length of the system. In the standard configuration the cable egress to the left; however, the design is flexible and allows them to egress to the right if desired.



Right or left hand cable egress

Miniature Positioners

Two Rail (8 Pole model shown)

Dimensions (mm)

Note: For edge mounting dimensions go to parkermotion.com CAD Drawing Files

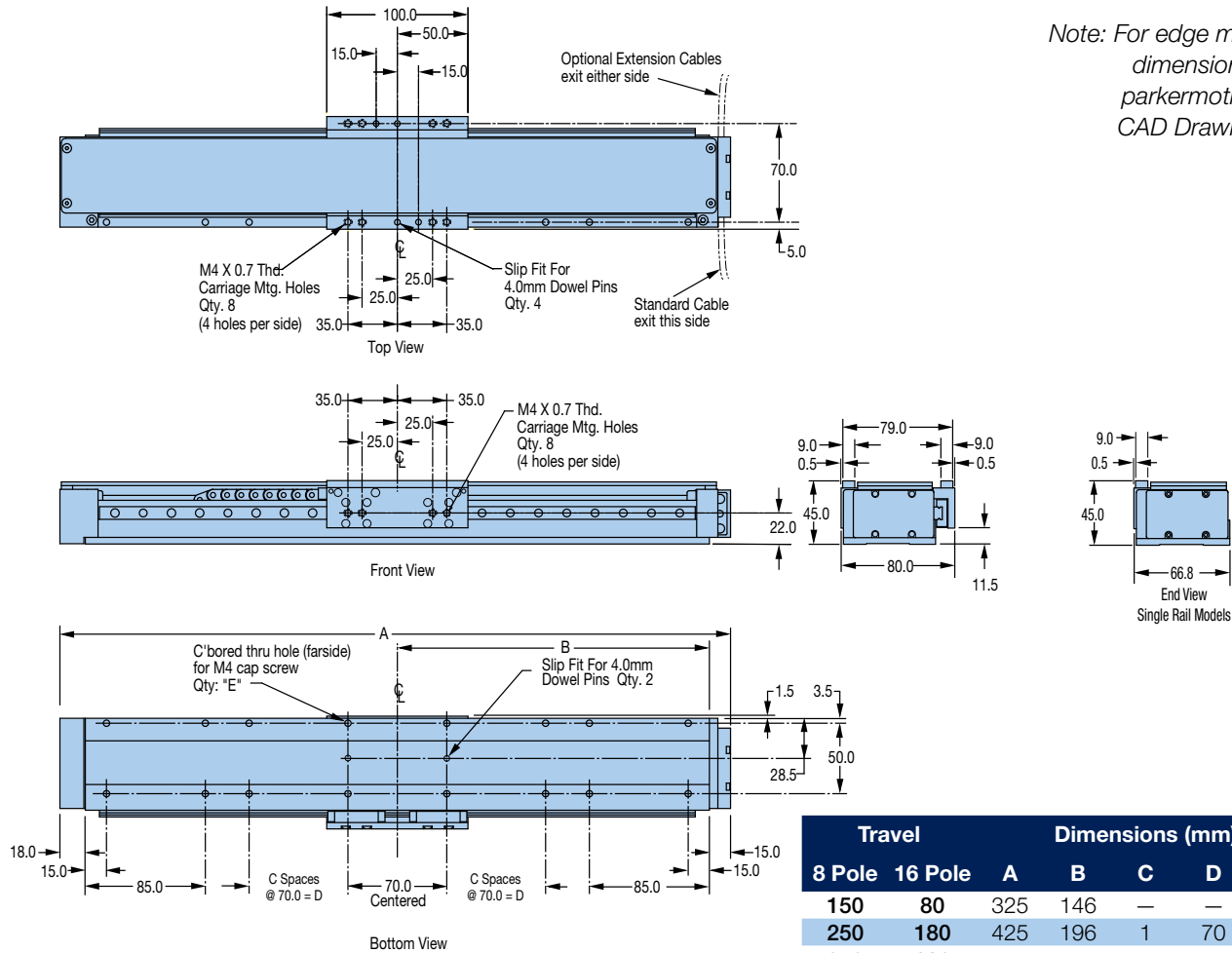

Carriage Mounting

One Rail - 8 Pole Model

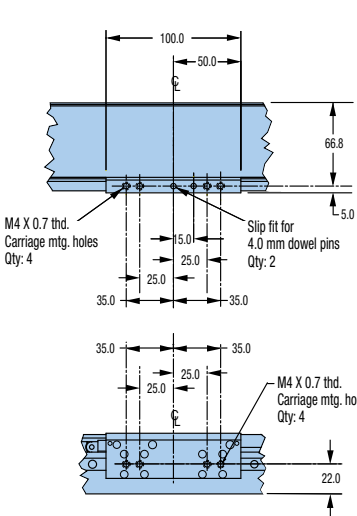

One Rail - 16 Pole Model

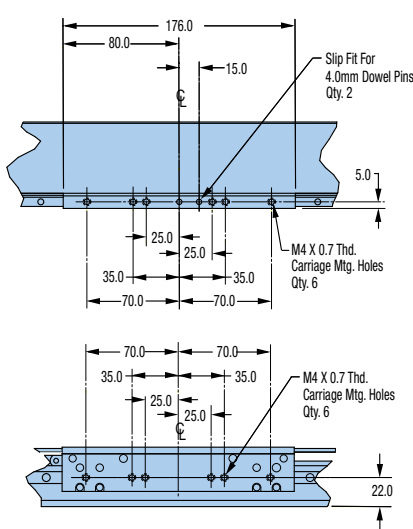

Two Rail - 16 Pole Model

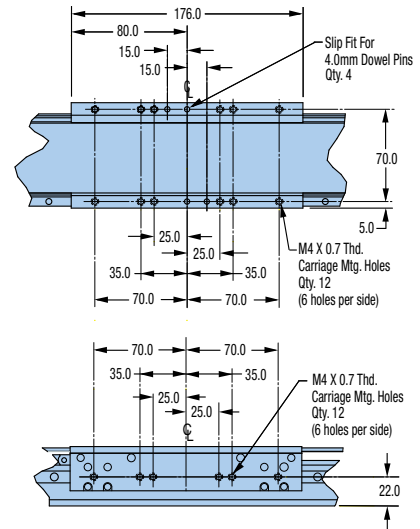



Fill in an order code from each of the numbered fields to create a complete model order code.

①	②	③	④	⑤	⑥	⑦	⑧	⑨	⑩	⑪	⑫	⑬
Order Example: LX80L T04 M P D D13 CM05 Z1 E3 R1 A25 X1 S1												
①	Series LX80L						⑧ Z Channel Location Z1 None Z2 Positive End Position					
②	Travel – mm						⑨ Digital Linear Encoder					
		8 Pole		16 Pole			E1 No encoder (free travel only) E2 1.0 µm Resolution E3 0.5 µm Resolution E4 0.1 µm Resolution E5 5.0 µm Resolution E7 Sine Output					
	T02	150		80								
	T04	250		180								
	T06	350		280								
	T08	450		380								
	T10	550		480								
	T14	750		680								
③	Mounting M Metric						⑩ Environmental R1 Standard Finish (black anodized) R2 Cleanroom Prep					
④	Grade P Precision						⑪ Digital Drive					
⑤	Bearing Type S Single Row D Double Row						A1 No Drive A20 ViX250-AH (torque mode) A21 ViX250-AH (velocity mode) A22 ViX250-AH (step/direction mode) A25 ViX250-IH Drive/Controller					
⑥	Drive Type D3 None – 8 pole carriage D7 None – 16 pole carriage D13 8 pole linear motor* D17 16 pole linear motor*						⑫ Required Designator X1					
							⑬ Axis Designator					
							S1 None (single-axis) S2 X-axis base unit (cables @ 12 o'clock) S3 Y-axis 60 arc-sec (cables @ 3 o'clock) S4 Y-axis 60 arc-sec (cables @ 9 o'clock) S5 Y-axis 15 arc-sec (cables @ 3 o'clock) S6 Y-axis 15 arc-sec (cables @ 9 o'clock)					
⑦	Cable Options CM03 Standard Finish (black anodized) CM04 High-flex Cables w/ViX connector, 1 meter CM05 High-flex Cables w/ViX connector, 3 meter											

Miniature Positioners



PROmech™ LP28 Miniature Linear Positioner

Features:

- Miniature profile
- Optimal length to travel ratio
- Travels from 5 mm to 500 mm
- Fully assembled package
- Multi-axis platform
- Motor included

Attributes:

- Miniature cross section (28 mm x 28 mm)
- High-performance leadscrew drive train
- 1 mm, 3 mm, 10 mm, and 1" screw lead options
- Recirculating linear bearing
- Travels selectable by the mm from 5 mm to 500 mm
- NEMA 11 or NEMA 17 stepper motors included as standard
- Fully adjustable home and limit sensors



Designed for OEMs needing simple positioning solutions for instrument and light industrial applications, the PROmech family of positioners offers a complete positioning solution at a price OEMs can afford to design into their equipment.

The PROmech LP28 is a packaged linear positioner whose completeness reduces OEM component selection and system design time. Further, PROmech positioners minimize re-engineering requirements because the positioner's design is already fully tested. Together these benefits help engineering teams keep aggressive project time lines on schedule and reduce time to market.

Once a design goes into production PROmech positioners help reduce both costs and assembly time. Building a linear motion axis from scratch requires the procurement, tracking, receiving, inventorying, kiting, assembly, and testing of about a dozen parts. Every time a component must be "touched" to help it navigate this process, it consumes part of a resource and adds a hidden cost of both time and money. Instead of a dozen parts, a PROmech positioner is a single piece, sourced from a domestic supplier with short lead times. PROmech positioners are easy to procure and once on the assembly floor, are quick to install.

Multi-axis Systems: Beyond the single-axis positioner many applications require XY or XYZ configurations. PROmech positioners are designed for multi-axis mounting and include features and accessories to enable this. To further minimize your assembly time, Parker can provide PROmech™ systems where we mount and align multiple axes together into a systems per your specification.

Whether you use 100 axes/year or 10,000 axes/year, Parker's PROmech series positioners offer the flexibility, reliability, and ease of use that will enable you to achieve your company's business objectives.

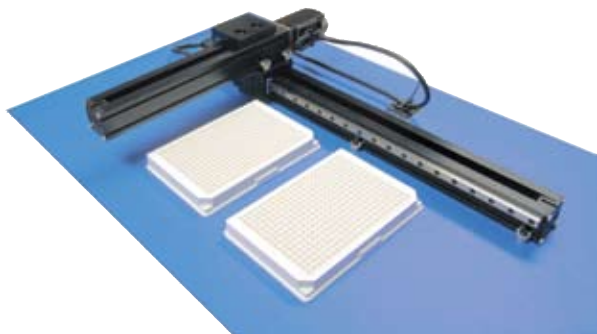



The PROmech design begins with an extruded aluminum body that provides aesthetic appeal, functionality, and structural strength. Internally, the drive train is highly integrated and includes the drive screw, screw nut, independent preloaded thrust bearing set, shaft coupling, and motor. Externally, an optional linear bearing may be used to support heavier or cantilevered payloads. Toe clamp mounting makes installation a snap. And finally, home and limit sensors which are triggered by a magnet in the carriage assembly may be mounted using the T-slot and are fully adjustable over travel.

The PROmech LP28 is engineered for transport of small payloads over distances as short as 5 mm and as long as 500 mm. The LP28 is commonly used in life sciences, medical, and semiconductor equipment although it is not limited to these markets. Typical applications include transport of 1 to 2 lb. payloads such as microplates, vials, and small syringe pumps. In inspection applications, the LP28 is excellent as a focus axis for adjusting the position of a camera, optics, or payload. The LP28's light weight also makes it suitable for mobile equipment as well.

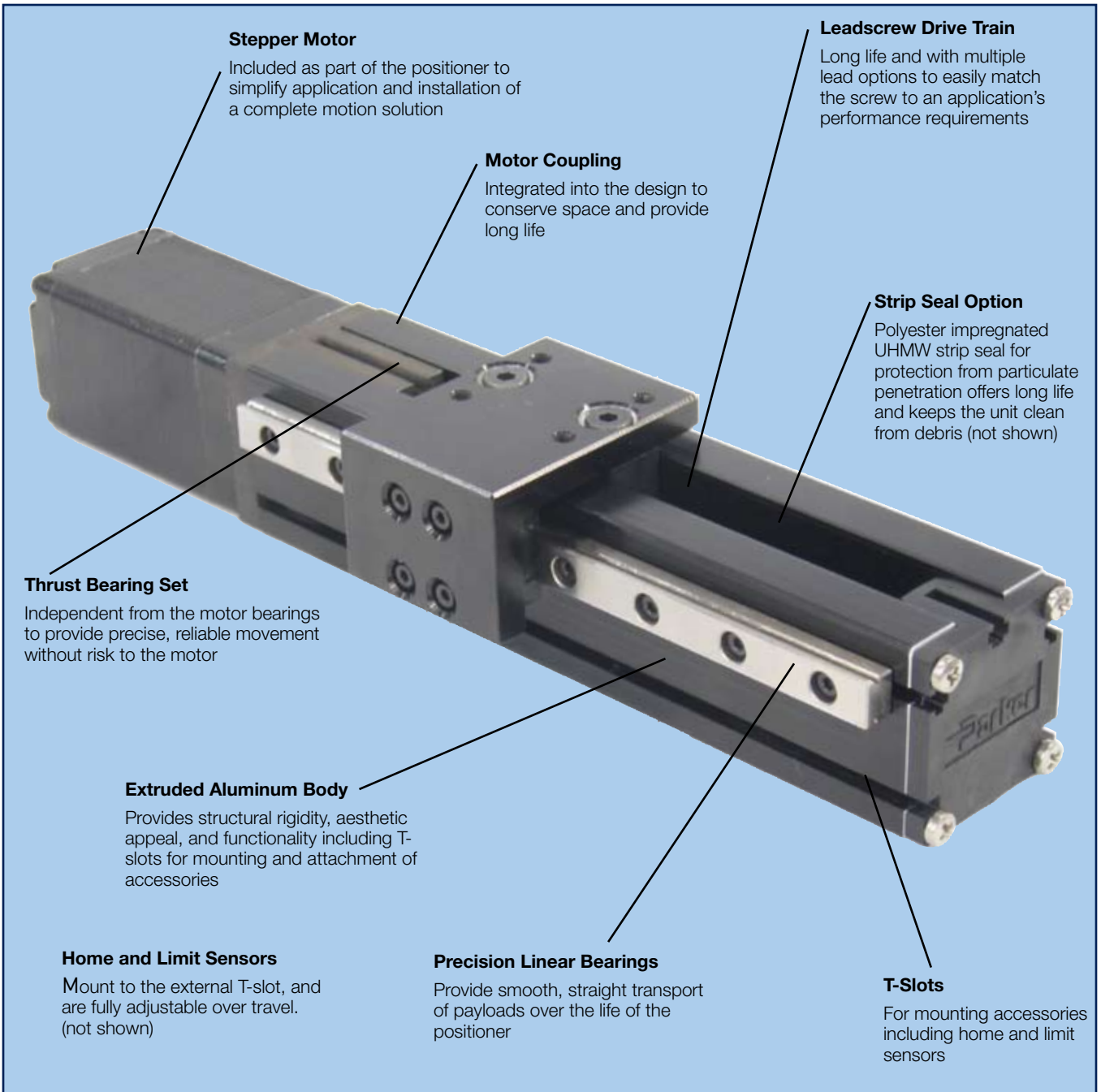

Miniature Positioners

Common Performance Characteristics

		1 mm Lead	3 mm Lead	10 mm Lead	1" Lead
Bidirectional Repeatability	µm	±50	±50	±100	±100
Duty Cycle	%	100	100	100	100
Maximum Acceleration	m/sec ² (ips ²)	20 (787)	20 (787)	20 (787)	20 (787)
Normal Load					
Single Bearing Carriage	Kgf (lb)	5 (11)	5 (11)	5 (11)	5 (11)
Double Bearing Carriage		10 (22)	10 (22)	10 (22)	10 (22)
Moment Load – Roll					
Single Bearing	Nm (in-lb)	0.5 (4.4)	0.5 (4.4)	0.5 (4.4)	0.5 (4.4)
Double Bearing		1.0 (8.8)	1.0 (8.8)	1.0 (8.8)	1.0 (8.8)
Moment Load – Pitch					
Single Bearing	Nm (in-lb)	0.5 (4.4)	0.5 (4.4)	0.5 (4.4)	0.5 (4.4)
Double Bearing		2.0 (18)	2.0 (18)	2.0 (18)	2.0 (18)
Moment Load – Yaw					
Single Bearing	Nm (in-lb)	0.5 (4.4)	0.5 (4.4)	0.5 (4.4)	0.5 (4.4)
Double Bearing		2.0 (18)	2.0 (18)	2.0 (18)	2.0 (18)
Maximum Thrust ⁽¹⁾	N (lbs)	45 (10)	45 (10)	45 (10)	45 (10)
Screw Efficiency	%	40	65	75	80
Breakaway Torque	Nm (oz-in)	0.02 (2.8)	0.02 (2.8)	0.03 (4.2)	0.03 (4.2)
Screw Diameter	mm	6.35	6.35	6.35	6.35
Coefficient of Friction		0.02	0.02	0.02	0.02

(1) See speed/thrust curves for combined motor-screw thrust capacity.

Travel Dependent Performance Characteristics

Travel mm	Maximum Speed – mm/s				Total Mass – Kg (lbs)		
	1 mm Lead	3 mm Lead	10 mm Lead	1.0" Lead	M11xx	M13xx	M71xx
5	15	45	150	375	0.39 (0.85)	0.48 (1.05)	0.52 (1.14)
25	15	45	150	375	0.42 (0.90)	0.51 (1.12)	0.55 (1.20)
50	15	45	150	375	0.46 (1.00)	0.55 (1.20)	0.59 (1.29)
75	15	45	150	375	0.49 (1.08)	0.58 (1.28)	0.62 (1.37)
100	15	45	150	375	0.53 (1.17)	0.62 (1.36)	0.66 (1.45)
150	15	45	150	375	0.61 (1.33)	0.70 (1.53)	0.74 (1.62)
200	15	45	150	375	0.68 (1.50)	0.77 (1.69)	0.81 (1.78)
250	15	45	150	375	0.76 (1.66)	0.85 (1.86)	0.89 (1.95)
300	15	45	150	375	0.83 (1.83)	0.92 (2.02)	0.96 (2.11)
350	15	45	150	375	0.91 (1.99)	1.00 (2.19)	1.04 (2.28)
400	15	45	150	375	0.98 (2.16)	1.07 (2.35)	1.11 (2.44)
450	15	45	150	375	1.06 (2.32)	1.15 (2.52)	1.19 (2.61)
500	15	45	150	375	1.13 (2.49)	1.22 (2.68)	1.26 (2.77)



Performance Graph Notes:

To simplify application, the different aspects of positioner performance, including motor torque, motor speed, screw efficiency, friction, safety margin, etc., have been consolidated into these speed versus thrust graphs. To make a selection first use the X axis scale of the different graphs to identify a screw lead that will deliver the desired peak velocity. Next, using the specific screw lead graph, identify the motor with enough torque to deliver the needed thrust to lift or accelerate the payload.

NEMA 11 stepper motor curves (M11xx and M13xx options) assume 24 VDC bus voltage at 0.67 amps. NEMA 17 stepper motor curves (M71xx options) assume 48 VDC bus voltage at 1.14 amps for series wound operation and 2.28 amps for parallel wound operation. All graphs

are limited to 45 N (10 lbs) of thrust due to mechanical limitations. Care should be taken not to stall the axis into the end of travel, particularly with the 1 mm lead screw (D01 options) as this motor-screw combination can generate significant amounts of thrust. All curves include a 10% safety margin.

The “Maximum Recommended Speed” is based on a maximum motor speed of 15 rps. Generally, the motors can rotate faster than 15 rps; however, at about 20 rps, they pass through a resonance which adversely and unpredictably affects usable motor torque. For applications requiring higher speeds, Parker recommends using a faster lead or a servo motor. Applications using a stepper motor above this recommended limit must be fully tested and qualified by the user.

Linear Speed-versus-Force Graphs

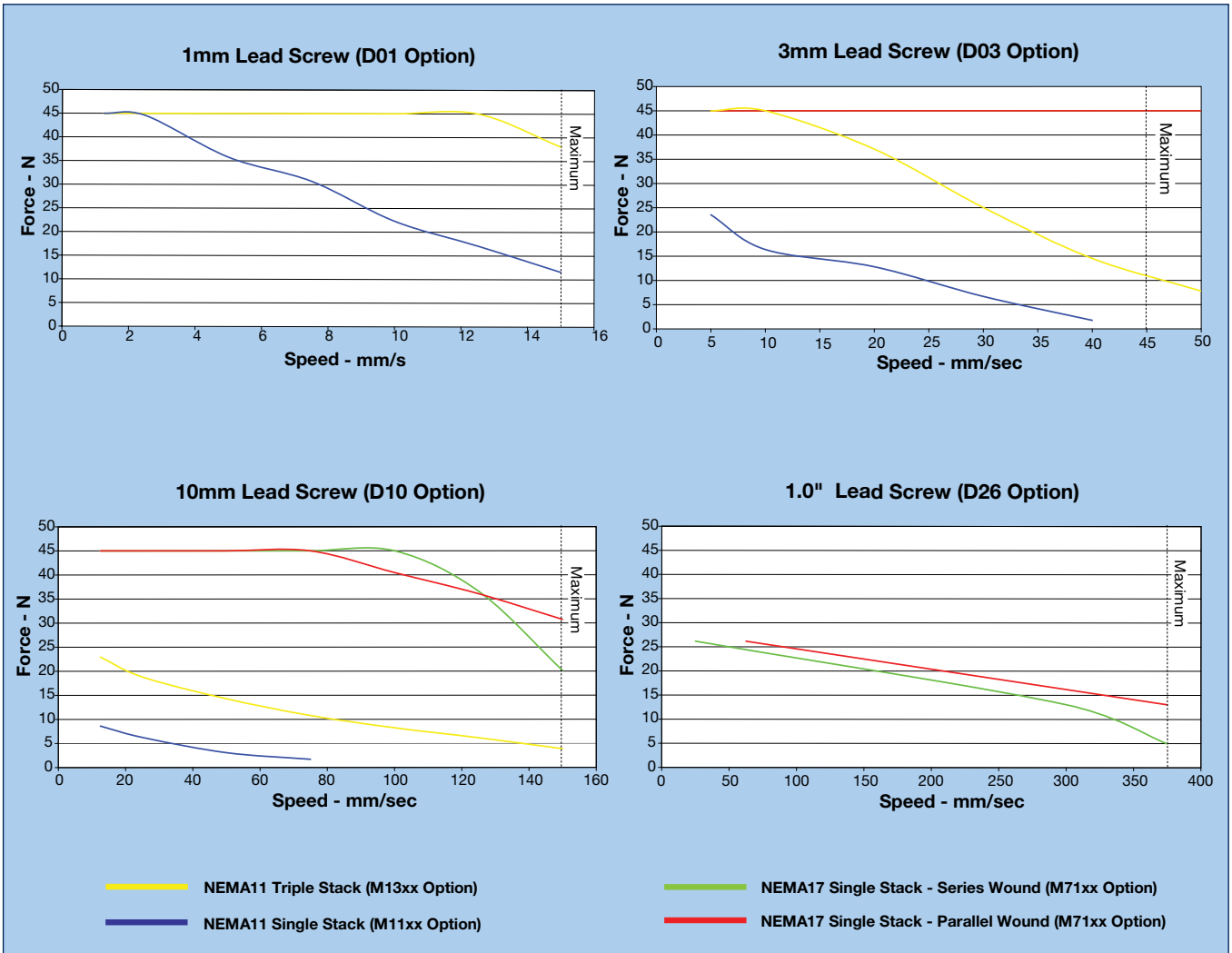

Miniature Positioners



Travel by the mm



Because the LP28 is miniature and must often fit into miniature spaces, the travel of the LP28 is selectable by the millimeter from 5 mm to 500 mm. This offers the greatest flexibility and enables designs to have the required travel with the minimum overall length.

Independent Thrust Bearings

Because high reliability and long life are critical requirements of OEM designs, the LP28 includes a pair of independent thrust bearings, dedicated to managing the positioner's axial loads. Some competitive miniaturized drive trains use the radial bearings in the step motor to contain the motor rotor, manage thermal expansion as the motor heats, and bear the axial loads generated by the application. In some cases this is an acceptable practice, but may prove to be a reliability risk down the road. The LP28's bearing design allows thrust bearings to be thrust bearings and motor bearings to be motor bearings resulting in a highly reliable and long life positioner.



Motor Coupling

Integrated into the PROmech design is a motor coupling. The innovative design minimizes part count and overall length, and, when necessary, enables a measure of flexibility when a special motor is required.



Optional Strip Seal

Promech offers a rugged polyester impregnated UHMW seal for anti-stretch and anti-wear characteristics providing protection for the lead screw and internal bearings. The seal provides protection to an IP30 rating and is matched to the black actuator body for optically sensitive environments. The strip seal is ordered under the bearing options and will slightly increase the overall length due to an extended length carriage.



Toe Clamp Mounting

Installation of the LP28 is very simple with toe clamps that may be placed anywhere along the base extrusion offering flexibility in the base mounting pattern. The cam style toe clamps can be "loosely" installed without the positioner. This allows fingers to quickly and efficiently place the toe clamps and start the screws without interference. Once started, the positioner can be placed and the toe clamps rotated into the lower slot and tightened. Toe clamps are available as an accessory and may be purchased in a 4 pack (part #002-2530-01) which is ideal for shorter travel units. For OEMs, toe clamps may be purchased in bulk (part #002-2531-01).

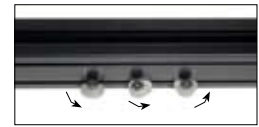

Multi-axis Mounting

The LP28 is designed to mount in XY and Cartesian arrangements with only toe clamps. Short travel Z axes can be attached using only toe clamps with longer travels requiring a standard Z-Bracket. Contact Daedal for more information.

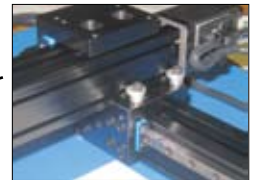
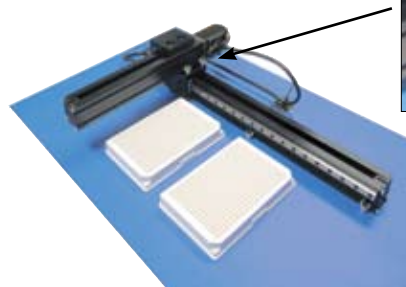



Screw Lead Flexibility

The PROmech Series offers 4 standard screw lead options: 1 mm lead, 3 mm lead, 10 mm lead, and 1.0" lead. Whether your application is slow and precise, long and fast, or somewhere in between, the options will allow you to performance match the drive train to your application.



Home and Limit Sensor Options

Home and Limit Sensors are available as a standard option. These attach to the side of the actuator using the T-slot and are activated by a magnet imbedded inside the carriage assembly. Four sensor types are available with all the N.O., N.C., NPN, and PNP variations. The sensors include 3.0 meters of cable. Home sensor options include 1 sensor and mounting hardware. Limit sensor options include 2 sensors and mounting hardware.



Input Power	10-30VDC
Voltage Drop	≤ 2.5V
Cont. Current	100mA
Electrical Protection	Short Circuit, Reverse Polarity, and Power Up Pulse Suppression
Enclosure	IP67 Rated Polyamide Housing with PVC Cable Jacket
Wire Colors	Brown – Power (+) Black – Signal Blue – Ground (-)
Cable Length	3.0 meter to flying leads

Order Code	Spare Part Number	Switch Type	Logic	Cable Type
H2 or L2	003-3743-07	N.C.	Sinking	3.0 meter to flying leads
H3 or L3	003-3743-05	N.O.	Sinking	3.0 meter to flying leads
H4 or L4	003-3743-08	N.C.	Sourcing	3.0 meter to flying leads
H5 or L5	003-3743-06	N.O.	Sourcing	3.0 meter to flying leads

Motor Options

The PROmech Series includes a number of standard motors. For most applications the NEMA 11 motors options will easily fulfill requirements. These are available in multiple stack lengths. The motors may include a rear shaft for encoder mounting or for manually positioning the stage. You may also choose between 12" flying motor leads or a 10' long cable. Further, the faster lead screw options will require the higher torque capacities of the standard NEMA 17 stepper. If you have special motor requirements such as a servo or DC motor, contact Daedal as these can be accommodated as well.



Encoder Options

Rotary encoders on the back of the motor are available. Contact Daedal for more information.



Linear Bearing Options

The PROmech Series offers 2 standard bearing options: a single linear rail with a single bearing truck or with two bearing trucks. These options provide flexibility to performance match the linear bearing system to your application.



Miniature Positioners

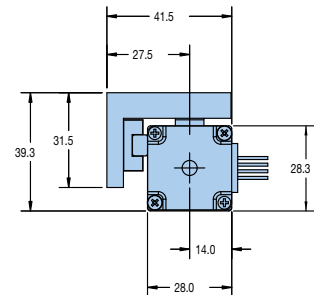
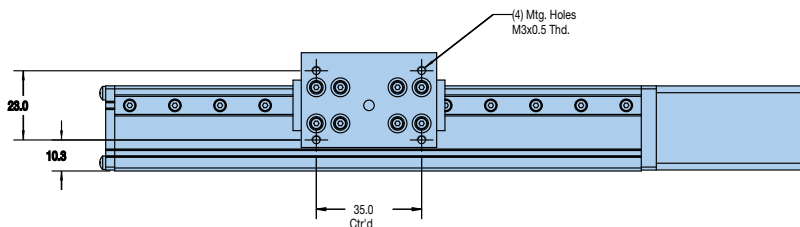
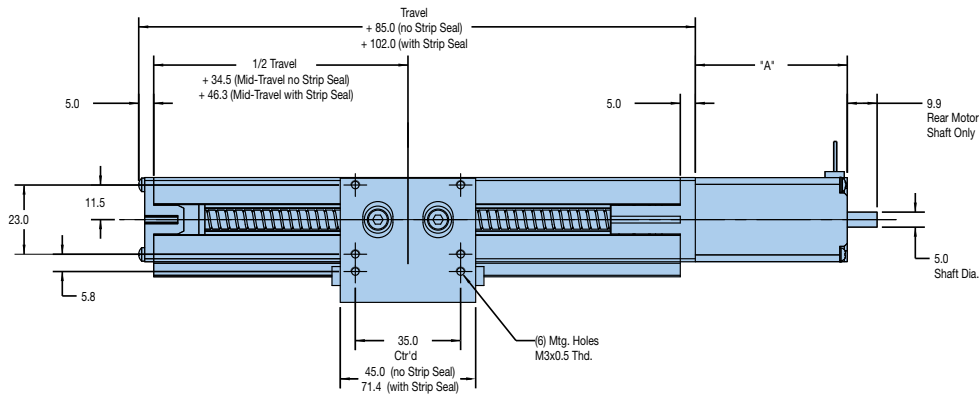

Single Bearing Truck (G21 Option)

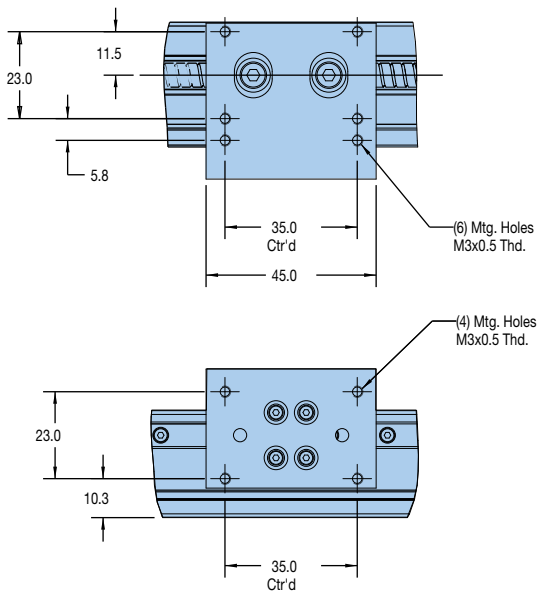

NEMA17 Motor Option (M71xx Option)

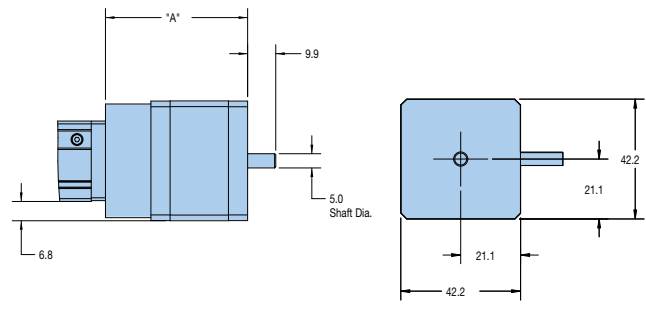

Limit Switch Accessories

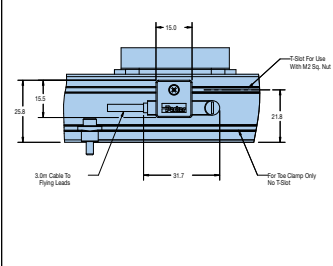

Toe Clamp Accessories

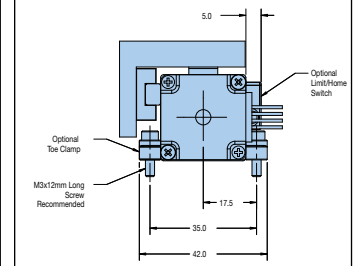

Model	"A" mm	Amps/Phase	Torque Nm (oz-in)	Resistance ohm/phase	Inductance mH	Rotor Inertia oz-in ²	Weight Kg (lb)	Wire Color
M11xx	31.5	0.67 Peak/0.5 RMS	0.06 (9.2)	5.6	3.4	0.05	0.11 (0.24)	A+ Red
M12xx	44.5	0.67 Peak/0.5 RMS	0.10 (13.7)	7.1	4.8	0.07	0.14 (0.31)	A- Black
M13xx	50.6	0.67 Peak/0.5 RMS	0.14 (16.6)	8.6	6.7	0.10	0.20 (0.40)	B+ White
M71xx (Series)	50	0.14 Peak/0.8 RMS	0.40 (56.0)	11.09	14.29	0.18	0.18 (0.40)	B- Green
M71xx (Parallel)	50	2.28	0.40 (56.0)	2.77	3.57	0.18	0.18 (0.40)	Refer to Manual



Fill in an order code from each of the numbered fields to create a complete model order code.

	①	②	③	④	⑤	⑥	⑦
Order Example:	LP28	T0050	D01	G31	M1111	H3	L2

- ① **Series**
LP28
- ② **Travel – mm**
Txxx Specify length in mm
- ③ **Drive**
D00 Idler only
D01 1 mm lead screw ⁽¹⁾
D03 3 mm lead screw
D10 10 mm lead screw
D26 1" lead screw ⁽²⁾
- ④ **Guide System**
G21 Linear Rail with 1 Bearing Truck, no seal
G22 Linear Rail with 1 Bearing Truck, with strip seal
G31 Linear Rail with 2 Bearing Trucks, no seal
G32 Linear Rail with 2 Bearing Trucks, with strip seal
- ⑤ **Motor**
M1111 Stepper, NEMA 11, 1 Stack, 12" Leads ⁽²⁾
M1112 Stepper, NEMA 11, 1 Stack, 10' Cable ⁽²⁾
M1321 Stepper, NEMA 11, 3 Stack, Rear Shaft, 12" Leads ⁽²⁾
M1322 Stepper, NEMA 11, 3 Stack, Rear Shaft, 10' Cable ⁽²⁾
M7122 Stepper, NEMA 17, 1 Stack, Rear Shaft, 10' Cable ⁽¹⁾
- ⑥ **Home Sensors ⁽³⁾**
H1 No Sensor
H2 N.C., Current Sinking, 3.0 m cable to flying leads
H3 N.O., Current Sinking, 3.0 m cable to flying leads
H4 N.C., Current Sourcing, 3.0 m cable to flying leads
H5 N.O., Current Sourcing, 3.0 m cable to flying leads
- ⑦ **Limit Sensors (quantity 2) ⁽³⁾**
L1 No Sensor
L2 N.C., Current Sinking, 3.0 m cable to flying leads
L3 N.O., Current Sinking, 3.0 m cable to flying leads
L4 N.C., Current Sourcing, 3.0 m cable to flying leads
L5 N.O., Current Sourcing, 3.0 m cable to flying leads

(1) D01 not available with M7xxx
 (2) D26 not available with M1xxx
 (3) Tables with travel 75 mm or less may have limited sensor capabilities and may be limited to 0, 1 or 2 sensors

Miniature Positioners



PROmech™ LD28 Miniature Linear Positioner

Features

- Miniature profile
- Independent thrust bearing set
- High thrust per package size
- Stepper or servo motor
- Stroke from 5 mm to 300 mm
- Backlash compensation

Attributes

- Miniature cross section (28 mm x 28 mm)
- High-performance leadscrew drive train
- 1 mm, 3 mm, 10 mm, and 1" screw lead options
- Anti-backlash nut design
- Travels selectable by the mm from 5 mm to 300 mm
- NEMA 11 or NEMA 17 stepper motors included as standard
- Independent, preloaded thrust bearing set for long life



Designed for OEMs needing simple positioning solutions for instrument and light industrial applications, the PROmech family of positioners offers a complete positioning solution at a price OEMs can afford to design into their equipment.

The PROmech LD28 is a packaged linear actuator whose completeness reduces OEM component selection and system design time. Further, PROmech positioners minimize re-engineering requirements because the positioner's design is already fully tested. Together these benefits help engineering teams keep aggressive project time lines on schedule and reduce time to market.

Once a design goes into production PROmech positioners help reduce both costs and assembly time. Building a linear motion axis from scratch requires the procurement, tracking, receiving, inventorying, kiting, assembly, and testing of about a dozen parts. Every time a component must be "touched" to help it navigate this process, it consumes part of a resource and adds a hidden cost of both time and money. Instead of a dozen parts, a PROmech actuator is a single piece, sourced from a domestic supplier with short lead times. PROmech actuators are easy to procure and once on the assembly floor, are quick to install.

The PROmech LD28 is engineered for thrusting small payloads over distances as short as 5 mm and as long as 300 mm. The LD28 is commonly used in life sciences, medical, and semiconductor equipment although it is not limited to these markets. Typical applications include syringe pumps and positioning stages. The LD28's light weight also makes it suitable for mobile equipment.

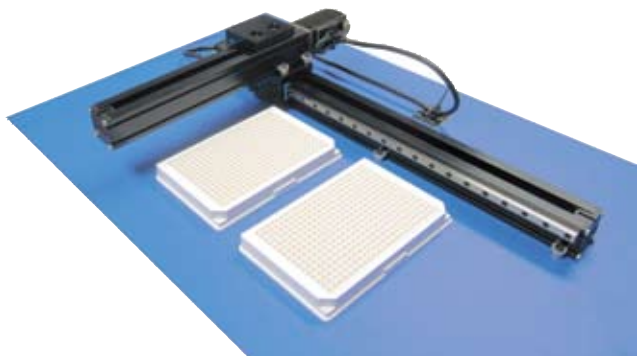



Customizable

Beyond the standard configurations, PROmech LD28 actuators can be customized to address the unique requirements of a particular high-volume application. These modifications may further reduce the installed cost and could include special motors (stepper, servo, or DC), special screws (finer leads, ballscrews, special nuts, etc.), and environmental preparation (vacuum, high temperature, etc.) just to mention a few.

Whether you use 10 axes/year or 10,000 axes/year, Parker’s PROmech series positioners offer the flexibility, reliability, and ease of use that will enable you to achieve your company’s business objectives.

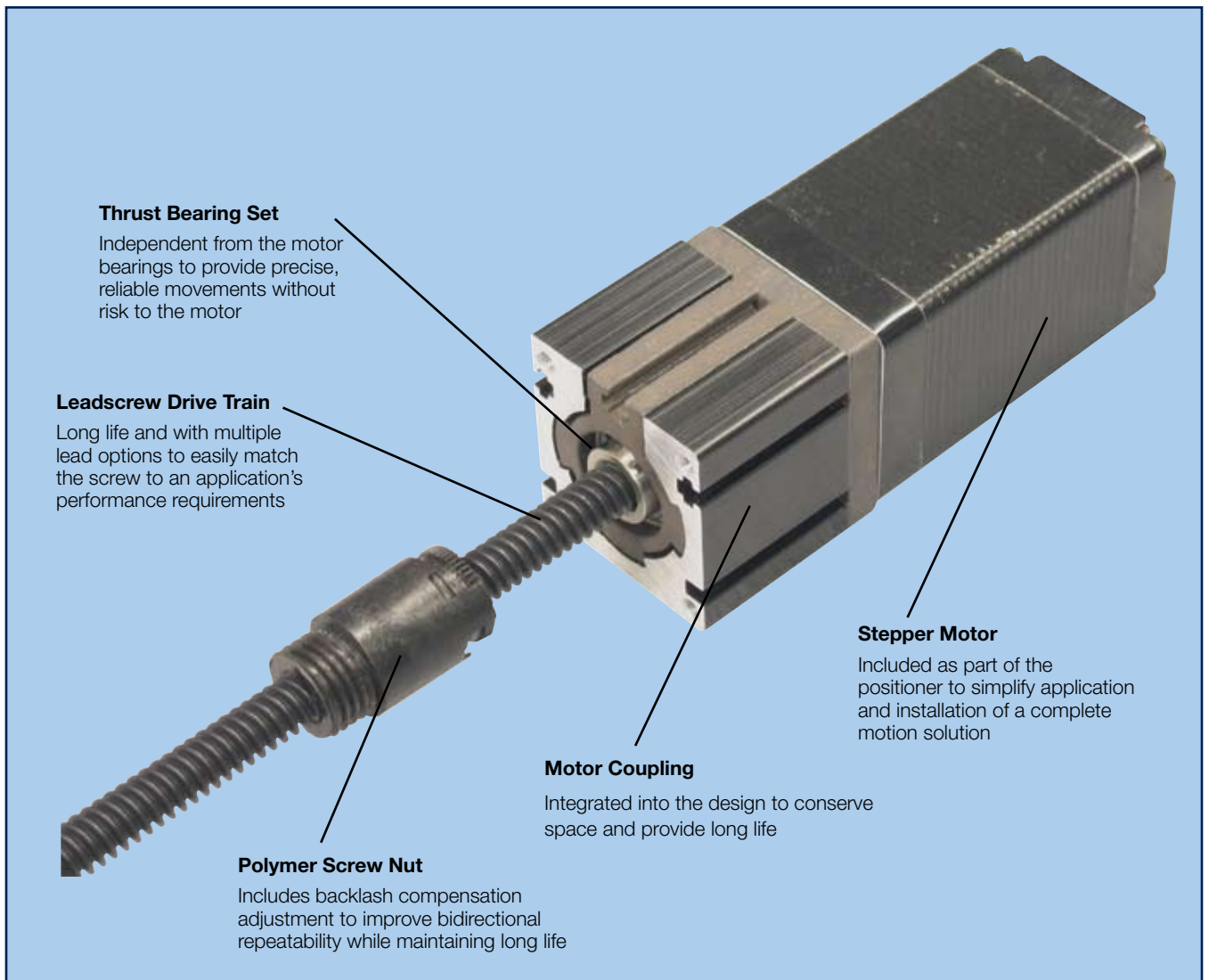

Miniature Positioners

Common Performance Characteristics

		1 mm Lead	3 mm Lead	10 mm Lead	1" Lead
Bidirectional Repeatability	µm	±50	±50	±100	±100
Duty Cycle	%	100	100	100	100
Maximum Acceleration	m/sec ² (ips ²)	20 (787)	20 (787)	20 (787)	20 (787)
Maximum Axial Load ⁽¹⁾	N (lb)	45 (10)	45 (10))	45 (10))	45 (10)
Screw Efficiency	%	40	65	75	80
Breakaway Torque	Nm (oz-in)	0.02 (2.8)	0.02 (2.8)	0.03 (4.2)	0.06 (8.5)
Screw Diameter	mm	6.35	6.35	6.35	6.35

(1) See speed/thrust curves for combined motor-screw thrust capacity.

Travel Dependent Performance Characteristics

Travel mm	Maximum Speed – mm/s				Total Mass – Kg (lbs)		
	1 mm Lead	3 mm Lead	10 mm Lead	1.0" Lead	M11xx	M13xx	M71xx
5	15	45	150	375	0.39 (0.85)	0.48 (1.05)	0.52 (1.14)
25	15	45	150	375	0.42 (0.90)	0.51 (1.12)	0.55 (1.20)
50	15	45	150	375	0.46 (1.00)	0.55 (1.20)	0.59 (1.29)
75	15	45	150	375	0.49 (1.08)	0.58 (1.28)	0.62 (1.37)
100	15	45	150	375	0.53 (1.17)	0.62 (1.36)	0.66 (1.45)
150	15	45	150	375	0.61 (1.33)	0.70 (1.53)	0.74 (1.62)
200	15	45	150	375	0.68 (1.50)	0.77 (1.69)	0.81 (1.78)
250	15	45	150	375	0.76 (1.66)	0.85 (1.86)	0.89 (1.95)
300	15	45	150	375	0.83 (1.83)	0.92 (2.02)	0.96 (2.11)
350	15	45	150	375	0.91 (1.99)	1.00 (2.19)	1.04 (2.28)
400	15	45	150	375	0.98 (2.16)	1.07 (2.35)	1.11 (2.44)
450	15	45	150	375	1.06 (2.32)	1.15 (2.52)	1.19 (2.61)
500	15	45	150	375	1.13 (2.49)	1.22 (2.68)	1.26 (2.77)



Independent Thrust Bearings

Because high reliability and long life are critical requirements of OEM designs, the LD28 includes a pair of independent thrust bearings, dedicated to managing the positioner's axial loads. Some competitive miniaturized drive trains use the radial bearings in the step motor to contain the motor rotor, manage thermal expansion as the motor heats, and bear the axial loads generated by the application. In some cases this is an acceptable practice, but may prove to be a reliability risk down the road. The LD28's bearing design allows thrust bearings to be thrust bearings and motor bearings to be motor bearings resulting in a highly reliable and long life positioner.



Motor Coupling

Integrated into the PROmech design is a motor coupling. The innovative design minimizes part count and overall length. And when necessary, enables a measure of flexibility when a special motor is required.



Toe Clamp or Tapped Face Mounting

Installation of the LD28 is very simple with the option to use toe clamps or T-Slots for mounting on surfaces that are parallel with the axis or a tapped face mount for surfaces that are perpendicular to the axis. The cam style toe clamps can be "loosely" installed without the positioner allowing fingers to quickly and efficiently place the toe clamps and start the screws without interference. Once started, the actuator can be placed and the toe clamps rotated into the lower slot and tightened. Toe clamps are available as an accessory and may be purchased in a 4 pack (part #002-2530-01) or in bulk (part #002-2531-01). The T-Slot enables a bolt to come through a surface into a T-nut and for the face mount, the LD28 includes four M2.5 tapped holes in a 23.1 mm square pattern.

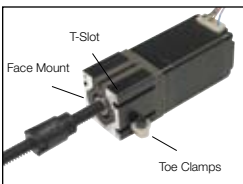

Motor Options

The PROmech Series includes a number of standard motors. For most applications the NEMA 11 motors options will easily fulfill requirements. These are available in multiple stack lengths. The motors may include a rear shaft for encoder mounting or for manually positioning the stage. You may also choose between 12" flying motor leads or a 10' long cable. Further, the faster lead screw options will require the higher torque capacities of the standard NEMA 17 stepper. If you have special motor requirements such as a servo or DC motor, contact Daedal as these can be accommodated as well.



Encoder Options

Rotary encoders on the back of the motor are available. Contact Daedal for more information.



Screw Lead Flexibility

The PROmech Series offers 4 standard screw lead options: 1 mm lead, 3 mm lead, 10 mm lead, and 1.0" lead. Whether your application is slow and precise, long and fast, or somewhere in between, the options will allow you to performance match the drive train to your application.



Travel by the mm

Because the LD28 is miniature and must often fit into miniature spaces, the travel of the LD28 is selectable by the millimeter from 5 mm to 300 mm. This offers the greatest flexibility and enables designs to have the required travel with the minimum overall length.

Miniature Positioners

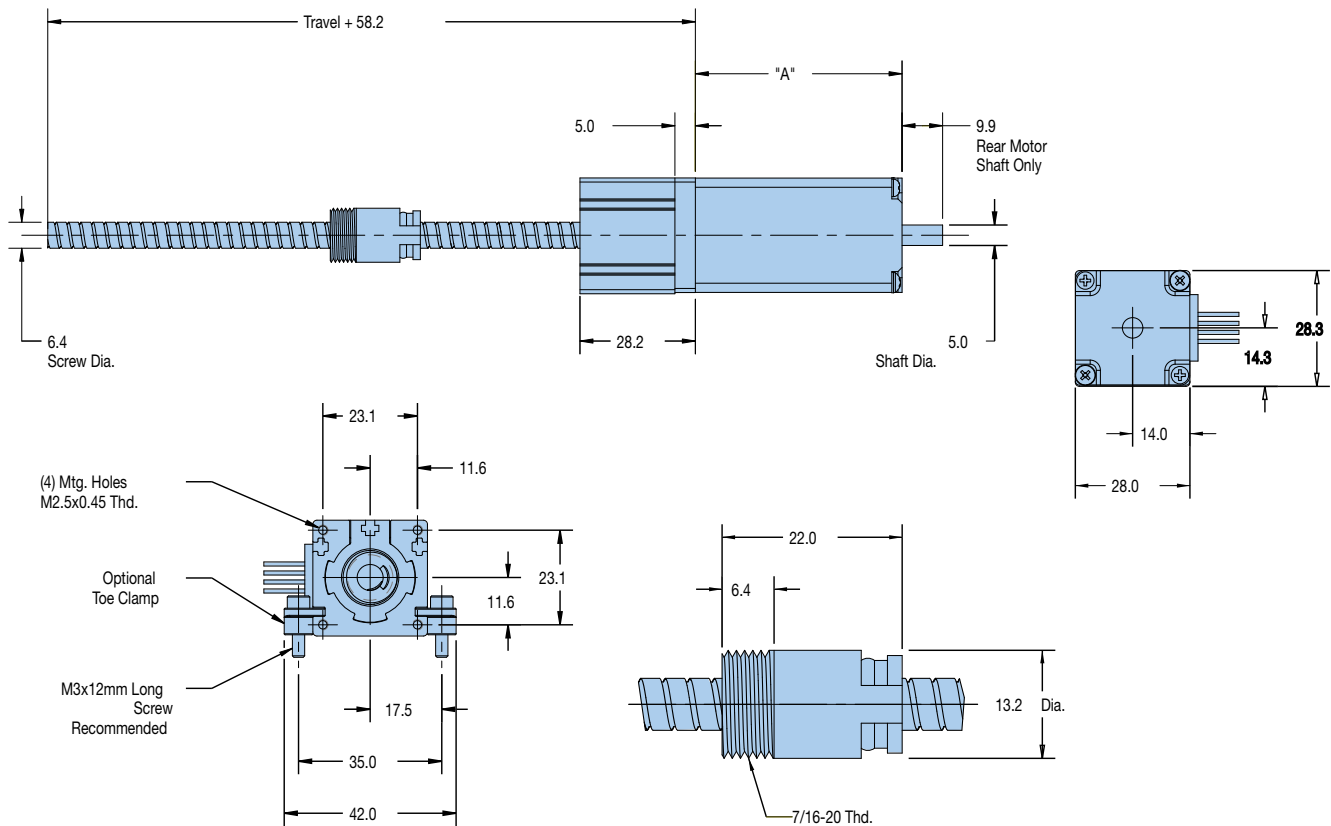

Model	"A" mm	Amps/Phase	Torque Nm (oz-in)	Resistance ohm/phase	Inductance mH	Rotor Inertia oz-in ²	Weight Kg (lb)	Wire Color
M11xx	31.5	0.67 Peak/0.5 RMS	0.06 (9.2)	5.6	3.4	0.05	0.11 (0.24)	A+ Red
M12xx	44.5	0.67 Peak/0.5 RMS	0.10 (13.7)	7.1	4.8	0.07	0.14 (0.31)	A- Black
M13xx	50.6	0.67 Peak/0.5 RMS	0.14 (16.6)	8.6	6.7	0.10	0.20 (0.40)	B+ White
M71xx (Series)	50	0.14 Peak/0.8 RMS	0.40 (56.0)	11.09	14.29	0.18	0.18 (0.40)	B- Green
M71xx (Parallel)	50	2.28	0.40 (56.0)	2.77	3.57	0.18	0.18 (0.40)	Refer to Manual



Fill in an order code from each of the numbered fields to create a complete model order code.

① ② ③ ④

Order Example: LD28 T0050 D01 M1111

- ① **Series**
LD28

- ② **Travel – mm**
Txxxx Specify length in mm

- ③ **Drive**
 - D00 Idler only
 - D01 1 mm lead screw ⁽¹⁾
 - D03 3 mm lead screw
 - D10 10 mm lead screw
 - D26 1" lead screw ⁽²⁾

- ④ **Motor**
 - M1111 Stepper, NEMA 11, 1 Stack, 12" Leads ⁽²⁾
 - M1112 Stepper, NEMA 11, 1 Stack, 10' Cable ⁽²⁾
 - M1321 Stepper, NEMA 11, 3 Stack, Rear Shaft, 12" Leads ⁽²⁾
 - M1322 Stepper, NEMA 11, 3 Stack, Rear Shaft, 10' Cable ⁽²⁾
 - M7122 Stepper, NEMA 17, 1 Stack, Rear Shaft, 10' Cable ⁽¹⁾

(1) D01 not available with M7xxx
 (2) D26 not available with M1xxx

Miniature Positioners

Accessories & Spare Parts

Availability		Part Number	Description
LP28	LD28		
•	•	002-2530-01	Toe Clamp Kit - Includes (4) Toe Clamps and (4) M3x12 SHCS
•	•	002-2531-01	Bulk Toe Clamps - Includes (100) Toe Clamps Only
•		002-2532-01	Sensor Mounting Kit - Includes Mounting Clip, M2 Square Nut, and M2x5 Pan Head Screw
•	•	002-2533-01	T-Nut Kit - Includes (10) M2 Square Nuts
•	•	002-2534-01	NEMA 17 Motor Adapter Kit - Includes Adapter, (4) M2.5x20 SHCS, and (4) M3x16 SHCS
•	•	003-3550-01	Motor, NEMA 11 Triple Stack, Rear Shaft, 12' Leads - For M1321 Option
•	•	003-3550-08	Motor, NEMA 11 Single Stack, 12' Leads - For M111 Option
•	•	003-3550-09	Motor, NEMA 11 Triple Stack, Rear Shaft, 10' Cable - For M1322 Option
•	•	003-3550-12	Motor, NEMA 11 Single Stack, 10' Cable - For M1112 Option
•	•	003-3551-01	M2.5x60 Pan Head Screw, Mounts NEMA 11 Triple Stack Motor
•	•	003-3551-02	M2.5x40 Pan Head Screw, Mounts NEMA 11 Single Stack Motor
•	•	003-3558-03	Coupling Hub, 5 mm Bore
•	•	003-3560-01	Coupling Torque Disk
•		003-3743-07	Sensor, N.C. Current Sinking, 3 m Cable to Flying Leads - For H2 or L2 Option
•		003-3743-05	Sensor, N.O. Current Sinking, 3 m Cable to Flying Leads - For H3 or L3 Option
•		003-3743-08	Sensor, N.C. Current Sourcing, 3 m Cable to Flying Leads - For H4 or L4 Option
•		003-3743-06	Sensor, N.O. Current Sourcing, 3 m Cable to Flying Leads - For H5 or L5 Option
•	•	003-3908-01	M2 Square Nut
•	•	101-1564-01	Toe Clamp
•	•	101-1567-01	NEMA 17 Motor Adapter
•	•	C*LV171-02-10	Motor, NEMA 17 Single Stack, Rear Shaft, 10' Cable - For M7122 Option
•	•	101-1564-01	Toe Clamp 101-1567-01 NEMA 17 Motor Adapter
•		002-2535-01	Strip Seal kit including 600 mm strip seal, and all necessary mounting hardware



Belt Driven high speed automation modules

For high speed automation, both gantry and articulated arm robots are widely used throughout industry. Because of the many inherent advantages of the gantry robot, it is a solid choice for: palletizing, storage and retrieval, machine loading, parts transfer, material handling, automated assembly. Parker offers numerous standard gantry configurations as well thousands of configured product options to develop a customer specific system solution to solve these and other automation applications. Utilization of these pre-engineered systems enables the user to redirect scarce engineering resources from motion system design to machine or process functionality.

Contents

196-199	Overview
200-213	HPLA Series
214-227	HLE-RB Series
228-239	HLE-SR Series
240-245	HLE-Z Series
246-251	HZR Series
252-253	BLMA Series
254-271	Gantry Robot Configurations
272-276	Options and Accessories for Belt Driven Modules
277-280	Additional Products

Parker's family of linear modules provides the most comprehensive line of high throughput linear positioning devices in the industry. These electromechanical positioners are designed to shuttle a payload at high speeds to multiple locations along a linear travel path. They serve as the primary building blocks for Parker pre-engineered gantry systems or customer designed automation systems. Parker linear modules are offered in several unique product families which can address a broad range of travel, speed, load, accuracy, and environmental requirements. There are three bearing systems (polyamide roller, steel roller, or square rail), three drive types (belt-and-pulley or rack-and-pinion, or linear servo motor), and up to six different cross sectional sizes (60, 80, 100, 120, 150 and 180 mm) from which to choose. Systems designed around these elements have effectively, efficiently, and economically satisfied the widest range of application requirements for high speed automation.

HPLA Series

Page 200-213



The next generation of belt driven modules, the HPLA expands on the roller wheel bearing design with the addition of high-load capacity steel wheels. The steel wheels significantly increase normal and moment load capacities of this belt driven actuator.

- Travel Range: 9.0 meters
- Load Capacity: 1530 kg
- Maximum Speed: 5 meters/sec.
- Duty Cycle: 100%
- Repeatability: ± 0.2 mm

HLE-RB Series

Page 214-227



These are the most popular electromechanical modules in the Parker line. They utilize a unique composite roller wheel bearing design coupled with a timing belt and pulley drive mechanism to provide long travel with high speed and high acceleration.

- Travel Range: 7.9 meters
- Load Capacity: 600 kg
- Maximum Speed: 5 meters/sec.
- Duty Cycle: 100%
- Repeatability: ± 0.2 mm

HLE-SR Series

Page 228-239



The "SR" series, having a square rail ball bearing system, complement the RB series by providing increased moment load capacities without an increase in profile size. The SR utilizes the same reliable timing belt and pulley drive system found in the RB.

- Travel Range: 6.0 meters
- Load Capacity: 600 kg
- Maximum Speed: 3 meters/sec.
- Duty Cycle: 100%
- Repeatability: ± 0.2 mm

HLE-Z Series

Page 240-245



The “endless” linear unit is designed for positioning payloads over long travel distances with high rigidity and repeatability. This is accomplished by incorporating Parker’s uniquely designed rack-and-pinion based drive system with the RB series roller wheel bearing system.

- Travel Range: 50 meters
- Load Capacity: 600 kg
- Maximum Speed: 5 meters/sec.
- Duty Cycle: 100%
- Repeatability: ± 0.05 mm

HZR Series

Page 246-251



The HZR is a vertical unit specifically designed to meet the high speed and force requirements of the automation industry. The fixed housing and movable aluminum extrusion permit the unit to retract out of the work area, thereby keeping the work area free of obstructions.

- Travel Range: 2.0 meters
- Load Capacity: 150 kg
- Maximum Speed: 5 meters/sec.
- Duty Cycle: 100%
- Repeatability: ± 0.2 mm

BLMA Series

Page 252-253

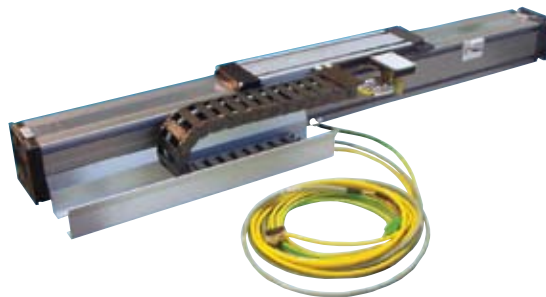

The BLMA is a plug and play linear motor actuator which houses a powerful linear servo motor (386 pounds of peak thrust) in a high strength rigid aluminum body to enable high end performance with highly repeatable positioning over long unsupported spans.

- Travel Range: 6.0 meters
- Load Capacity: 700 kg
- Maximum Speed: 7 meters/sec.
- Duty Cycle: 100%
- Repeatability: ± 0.01 mm

Gantry Systems

Page 254-269

Parker's gantry systems provide cost-effective, easy to integrate solutions that satisfy the vast majority of automation requirements. In addition to these standard gantry systems, Parker offers products with additional capabilities to fulfill the needs of special applications. Our engineering skill and manufacturing expertise have integrated these products into custom-tailored gantry solutions which have successfully addressed the most unique and exacting requirements of machine builders and integrators around the world.



Support Structures

Page 270

Parker can include the support structure and machine guarding as part of your complete system solution. Parker's ParFrame™ extruded aluminum structures are suited for light to medium duty requirements. High strength steel supports are offered for applications involving greater loads and forces.

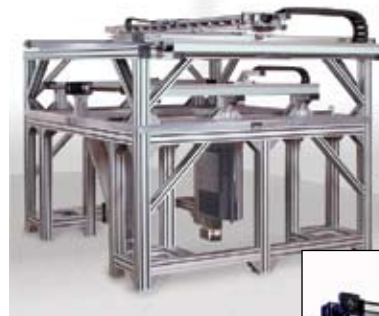

**Motors, Drives, and Controls
(Electrical Subsystems)**

Page 271

A high speed multi-axis Gantry Robot requires a complete electromechanical solution where the machine Interface, Control and Motor/Drive functions are seamlessly integrated with the mechanical elements. Parker's wide range of electrical products and subsystems enable Gantry Robots to be supplied to the customer at the level of integration most suitable for his need. Whether you need a basic mechanical unit, a unit including drives and motors, or a full-blown electromechanical system ready to run or link to a PLC, Parker has the best solution.



Additional Capabilities

Page 277-280



HDM Series Rotary Motion Modules



ET Series Rod Style Electric Cylinders



HTR Telescopic Vertical Units

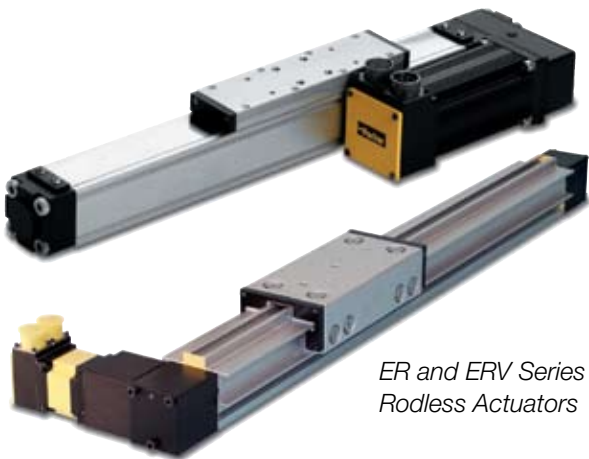

ER and ERV Series Rodless Actuators



**Belt Driven
Tables**



LCB Series Compact Rodless Actuators

HPLA Series Belt Driven Linear Modules

Features

- Strong – steel roller bearing option for highest load capacity – 1530 kg
- Rugged construction for heavy duty applications
- Thrust force capacity to 5455 N
- Standard travel up to 9 meters
- Velocity up to 5 meters/sec.
- Positional repeatability of ± 0.2 mm
- Timing belt and pulley drive mechanism for fast, accurate positioning

The Modular Concept

Provides the ideal solution for applications:

Modular drive system:

- Increased system stiffness due to larger belt width
- Low maintenance
- High performance due to hollow shaft input

Modular guide system:

- Provides an alternative to composite wheel material
- Quiet operation
- Low maintenance
- Steel wheel option on an integrated steel rolling surface for increased load capacity
- High load-bearing capacity
- High levels of rigidity

Various options for adaptation to wide ranging applications:

- Steel cover strip
- Corrosion-resistant stainless steel version for application in clean rooms or in the food industry
- Integrated position feedback system for maximum precision
- Optional IP30 rated strip seal



HPLA Encoder Option

See pages 272-276 for available options and accessories.



Proven Technology

- Direct mounting for planetary gear reducers – eliminating complexity of additional machined parts or couplings
- Adjustable “end of travel” limit switches and “Home” position sensor
- Cable carrier systems
- Performance matched Parker servo systems
- Structural components for vertical and multi-axis mounting
- Toe clamps and hardware for fast/easy mounting
- External bumper option
- Link shafts and support bearing for dual unit axes
- Splice plates for extending travels beyond length available in a single profile

Typical Fields of Application

As part of advanced, cost-effective construction of machines and handling systems:

- Materials handling: palletizing, depalletizing, feeding, part removal
- Cleanroom technology: wafer transport, wafer coating
- Warehouse technology: parts picking, storage and retrieval
- Machine tool automation: workpiece loading and unloading, tool changing
- Construction: formwork, placing reinforcing steel bars in concrete
- Process engineering: painting, coating, bonding
- Testing technology: guiding ultrasonic sensors, laboratory equipment
- Textile machinery building: cross-cutting, slitting and stacking, quilting, seam stitching



The HPLA is a rugged “next generation” linear module that offers high speed, high acceleration, and long travel, combined with stiff, rigid construction characteristics. It is ideally suited as a single axis product or as a component for high speed multi-axis gantries. The HPLA carriage is rigidly supported on three sides by heavy duty roller bearings, housed in a rugged aluminum housing. The bearing wheels are pre-loaded via eccentric bushings to eliminate play in the system, and are strategically located to evenly distribute the load across the length of the carriage.

A high strength steel reinforced drive belt and pulley system provides fast and highly repeatable positioning of the carriage. This high thrust drive belt is securely connected to the carriage by a unique clamping system. This system provides a secure connection and enables easy belt replacement without the need to remove the payload. Having a low coefficient of friction, the carriage design provides a high mechanical efficiency and long service life. Special carriage lengths and linear units with multiple carriages are available for custom applications.

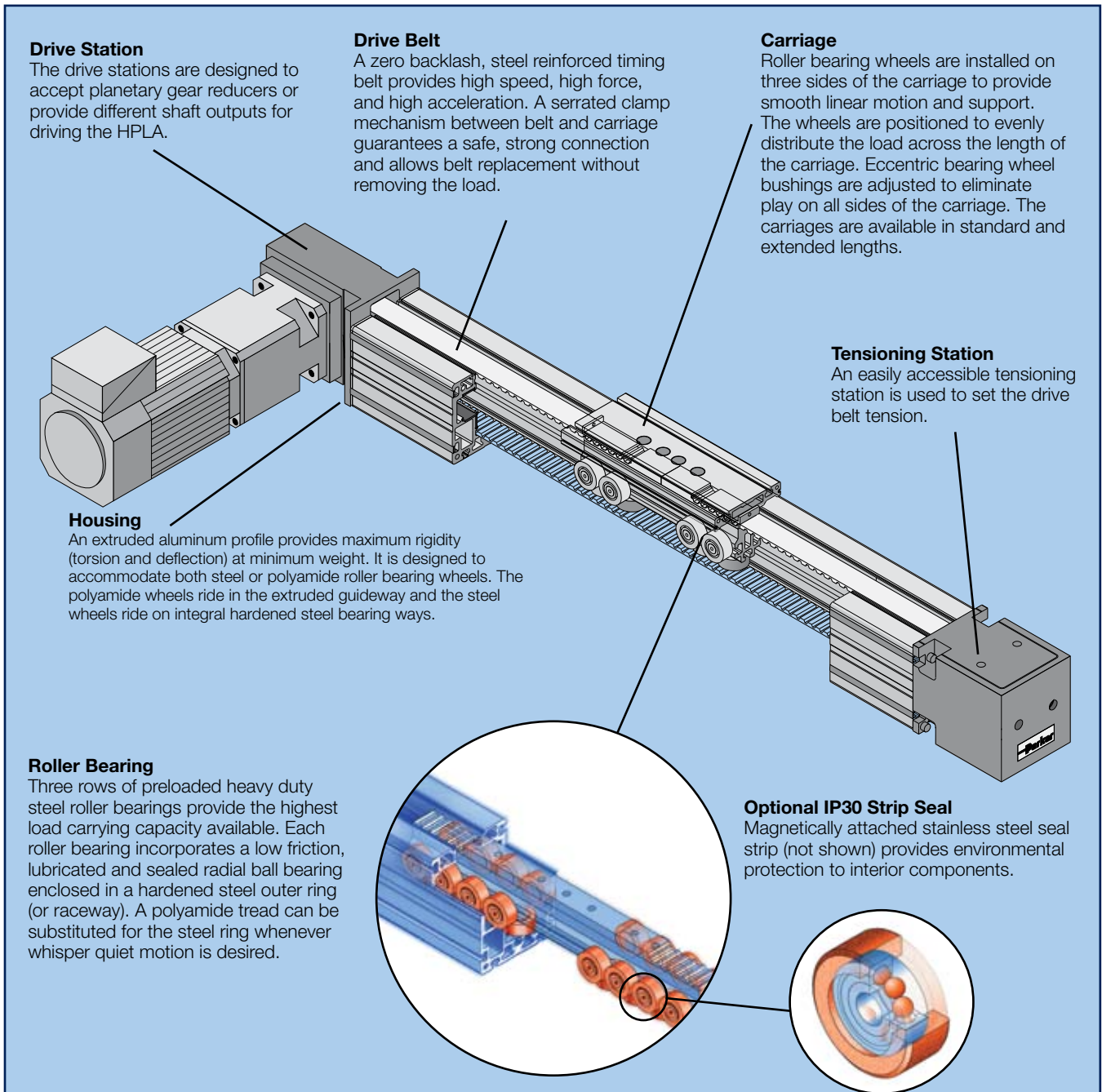

Belt Driven Tables

HPLA Series Specifications

Characteristic	Units	HPLA80		HPLA120		HPLA180		HPLA180 (Rack Drive)
		Polyamide Wheel	Steel Wheel	Polyamide Wheel	Steel Wheel	Polyamide Wheel	Steel Wheel	Polyamide Wheel
Unit Weight (basic unit without stroke)								
Standard Carriage, NL	kg (lb)	6.8 (15.0)	7.5 (16.5)	20.2 (44.4)	21.6 (47.5)	57.2 (125.8)	61.6 (135.3)	78.4 (172.5)
Extended Carriage, VL	kg (lb)	8.6 (18.9)	9.5 (20.9)	25.2 (55.4)	27.1 (59.6)	74.8 (164.6)	80.9 (178.0)	95.2 (209.4)
Carriage Weight								
Standard Carriage, NL	kg (lb)	1.7 (3.7)	1.8 (4.0)	5.8 (12.8)	6.0 (13.2)	12.3 (27.1)	12.6 (27.7)	32.5 (71.5) ⁽¹⁾
Extended Carriage, VL	kg (lb)	2.6 (5.7)	2.8 (6.2)	8.8 (19.4)	9.2 (20.2)	21.1 (46.4)	21.8 (48.0)	39.8 (87.6) ⁽¹⁾
Weight/Meter of Additional Travel	kg/m (lb/ft)	6.1 (4.1)	7.3 (4.9)	13.7 (9.2)	15.5 (10.4)	29.4 (19.8)	33.6 (22.6)	31.5 (21.2)
Moment of Inertia (related to the drive shaft)								
Standard Carriage, NL	kg-cm ² (lb-in ²)	17.8 (6.1)	18.4 (6.3)	142 (48)	146 (50)	725 (247)	743 (253)	698 (238)
Extended Carriage, VL	kg-cm ² (lb-in ²)	25.4 (8.7)	26.5 (9.0)	197 (67)	204 (70)	1121 (382)	1154 (393)	845 (288)
Travel and Speed								
Maximum Speed ⁽²⁾	m/s (in/s)	5 (200)		5 (200)		5 (200)		5 (200)
Maximum Acceleration ⁽²⁾	m/s ² (in/s ²)	10 (393)		10 (393)		10 (393)		10 (393)
Max. Travel, Standard Carriage NL ⁽³⁾	mm (in)	5540 (218)	5520 (217)	9470 (372)	9440 (371)	9240 (363)	9200 (362)	8680 (341)
Max. Travel, Extended Carriage VL ⁽³⁾	mm (in)	5390 (212)	5370 (211)	9270 (365)	9240 (363)	8940 (352)	8900 (350)	8380 (330)
Geometric Data								
Cross Section, Square	mm (in)	80 (3.15)		120 (4.72)		180 (7.09)		180 (7.09)
Moment of Inertia Ix	cm ⁴ (in ⁴)	139 (3.34)		724 (17.39)		3610 (86.73)		3610 (86.73)
Moment of Inertia Iy	cm ⁴ (in ⁴)	165 (3.96)		830 (19.94)		4077 (97.95)		4077 (97.95)
Moment of Elasticity	N/mm ² (lb/in ²)	0.72 x 10 ⁵ (0.1044 x 10 ⁶)		0.72 x 10 ⁵ (0.1044 x 10 ⁶)		0.72 x 10 ⁵ (0.1044 x 10 ⁶)		0.72 x 10 ⁵ (0.1044 x 10 ⁶)
Pulley Data, Torques, Forces								
Travel Distance per Revolution	mm/rev (in/rev)	180 (709)		270 (10.63)		420 (16.54)		280 (11.02)
Response Radius of Drive Pulley	mm (in)	28.7 (1.13)		43.0 (1.69)		66.8 (2.63)		44.6 (1.75)
Maximum Drive Torque	Nm (lb-in)	47.4 (420)		131.4 (1165)		368 (3264)		58 (514)
Maximum Belt Traction (effective load)		Refer to charts on following pages						
Repeatability ⁽³⁾⁽⁴⁾	mm (in)	± 0.2 (± 0.008)		± 0.2 (± 0.008)		± 0.2 (± 0.008)		± 0.05 (± 0.002)

(1) Includes weight of drive module.

(2) Greater speeds and accelerations may be achieved.

(3) Bumper to bumper maximum stroke - splicing possible for longer travel distances including safety zone.

(4) Nominal value - component dependent. For improved repeatability consult factory.

Linear Actuator Size Comparison

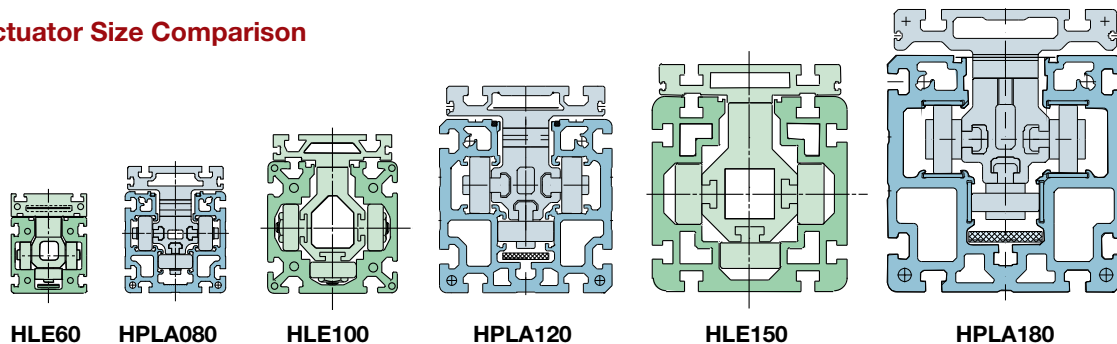



HPLA080 Series – Load-Bearing Capacity of Carriage and Timing Belt

Load-Bearing Capacity of HPLA080 Timing Belt (F_x)

Drive Option	Transferable Thrust Force (n)	
	Nominal Belt Tension (81,000 km life)	Maximum Belt Tension (46,000 km life)
Supported Pulley (S03, S04, S08, S09)	925	1115
Unsupported Pulley (S01, S02)		
W/GTN090	675	900
PEN115	675	900
PEN090	500	665

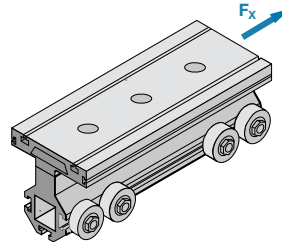

The forces and moments that the carriage is capable of transferring are speed-dependent. The curves shown in the graphs apply to a standard carriage (S). With the extended carriage (E), all the values apart from F_x (load-bearing capacity of timing belt) can be doubled if the load is applied equally to both halves of the carriage or distributed uniformly along its entire length.

HPLA080 Load-Bearing Capacity (F_y and F_z)

(Values double for extended carriage)

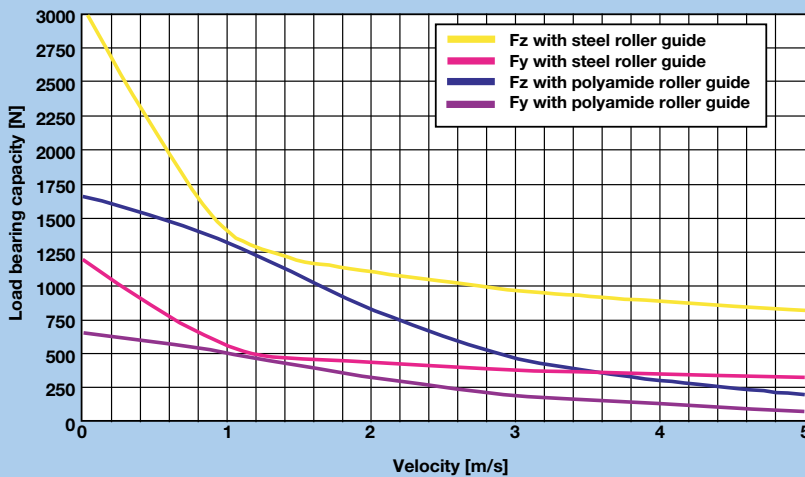

The curves show the maximum load-bearing capacity of a carriage in one direction of force or torque. If several loads are applied in different directions, the values given by the curves must be derated, i.e. the load or speed should be reduced if necessary.

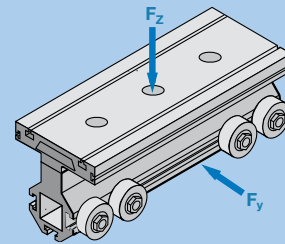

“DimAxes” software is available for determination of precise carriage loading.

Visit www.parkermotion.com to request a Gantry Robot CD.

HPLA080 Maximum Permissible Moment Load (M_x , M_y and M_z)

(Values double for extended carriage)

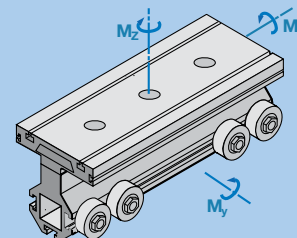
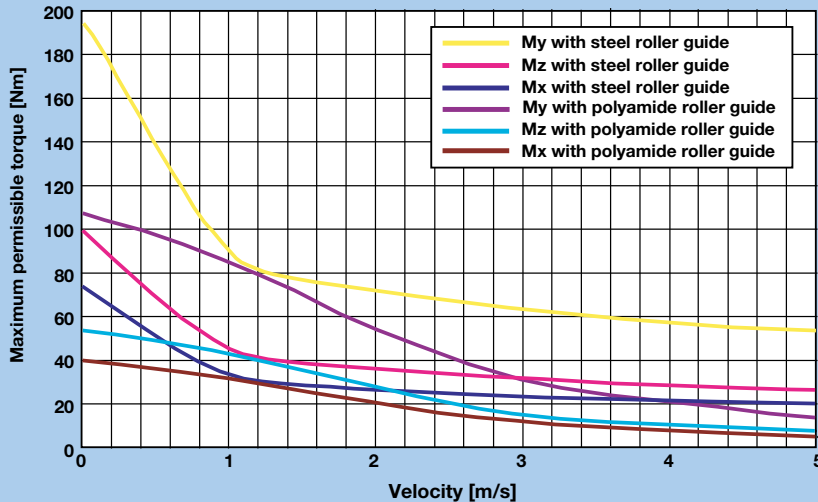

HPLA120 Series – Load-Bearing Capacity of Carriage and Timing Belt

Load-Bearing Capacity of HPLA120 Timing Belt (Fx)

Drive Option	Transferable Thrust Force (n)	
	Nominal Belt Tension (85,000 km life)	Maximum Belt Tension (37,000 km life)
Supported Pulley (S03, S04, S08, S09)	1700	2235
Unsupported Pulley (S01, S02)		
W/GTN115	1515	2015
W/GTN090	675	900
PEN115	675	900

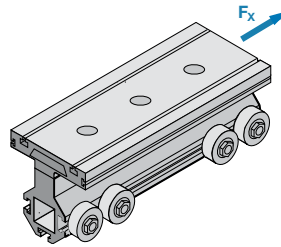

The forces and moments that the carriage is capable of transferring are speed-dependent. The curves shown in the graphs apply to a standard carriage (S). With the extended carriage (E), all the values apart from Fx (load-bearing capacity of timing belt) can be doubled if the load is applied equally to both halves of the carriage or distributed uniformly along its entire length.

HPLA120 Load-Bearing Capacity (Fy and Fz)

(Values double for extended carriage)

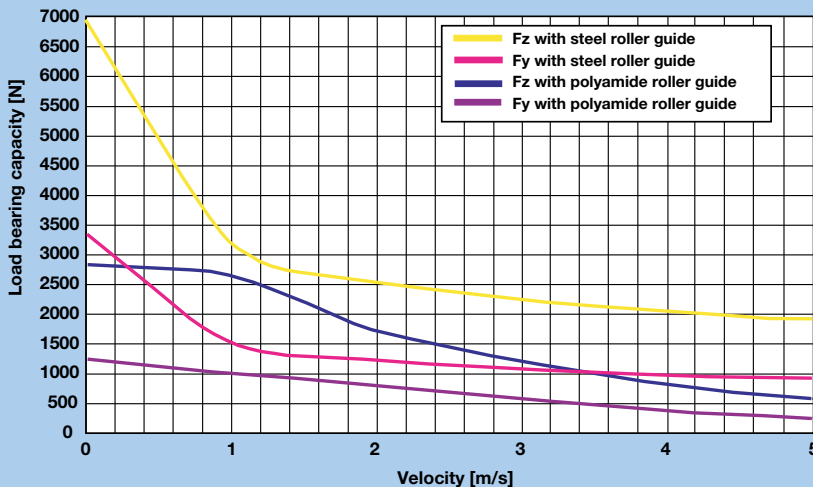

The curves show the maximum load-bearing capacity of a carriage in one direction of force or torque. If several loads are applied in different directions, the values given by the curves must be derated, i.e. the load or speed should be reduced if necessary.

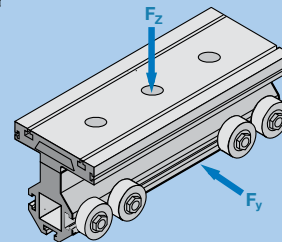

HPLA120 Maximum Permissible Moment Load (Mx, My and Mz)

(Values double for extended carriage)

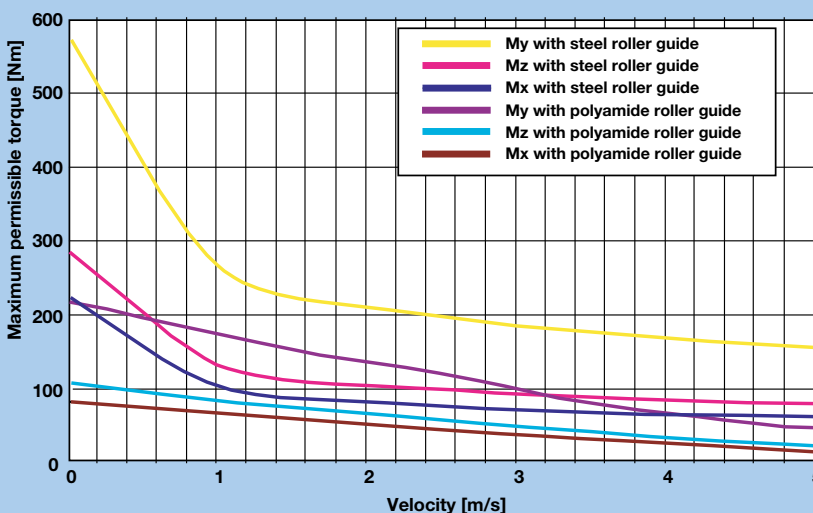

“DimAxes” software is available for determination of precise carriage loading.
Visit www.parkermotion.com to request a Gantry Robot CD.

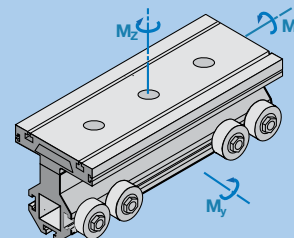



HPLA180 Series – Load-Bearing Capacity of Carriage and Timing Belt

Load-Bearing Capacity of HPLA180 Timing Belt (F_x)

Drive Option	Transferable Thrust Force (n)	
	Nominal Belt Tension (100,000 km life)	Maximum Belt Tension (45,000 km life)
Supported Pulley (S03, S04, S08, S09)	4170	5455
Unsupported Pulley (S01, S02)		
W/GTN142	1405	1804
W/GTN115	1065	1400

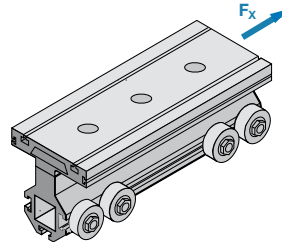

The forces and moments that the carriage is capable of transferring are speed-dependent. The curves shown in the graphs apply to a standard carriage (S). With the extended carriage (E), all the values apart from F_x (load-bearing capacity of timing belt) can be doubled if the load is applied equally to both halves of the carriage or distributed uniformly along its entire length.

HPLA180 Load-Bearing Capacity (F_y and F_z)

(Values double for extended carriage)

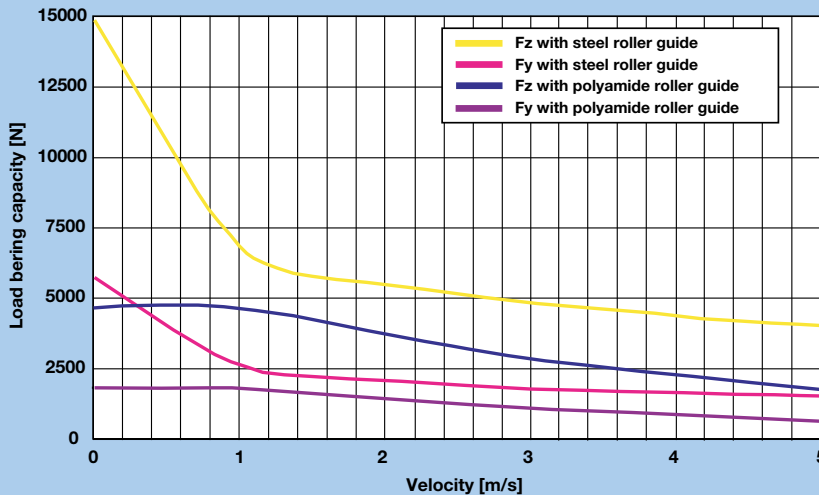

The curves show the maximum load-bearing capacity of a carriage in one direction of force or torque. If several loads are applied in different directions, the values given by the curves must be derated, i.e. the load or speed should be reduced if necessary.

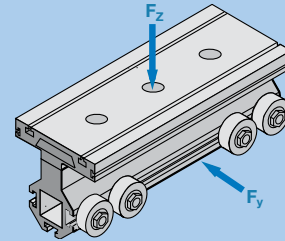

“DimAxes” software is available for determination of precise carriage loading.

Visit www.parkermotion.com to request a Gantry Robot CD.

HPLA180 Maximum Permissible Moment Load (M_x , M_y and M_z)

(Values double for extended carriage)

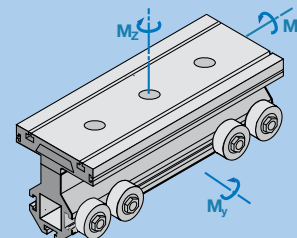
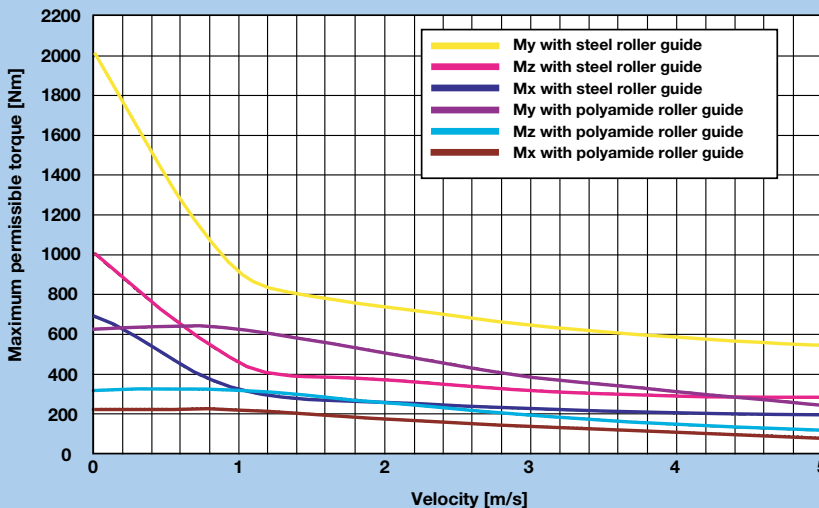

Belt Driven Tables

HPLA Characteristics

The HPLA deflection curves can be used for determining the deflection based on the profile length and the application load weight. Applications requiring high acceleration forces can place a severe strain on the system stability. In these cases, a solid substructure may be required with the HPLA product being supported at frequent intervals.

These deflection curves illustrate the deflection δ , based on the HPLA profile being simply supported at both ends. The graphs take into consideration the self deflection due to the weight of the profile, along with the load to be transported. The maximum deflection cannot be exceeded. If the maximum deflection is exceeded based on your application parameters, then additional supports are required. Alternatively, the next larger profile size may be considered. For deflection formulas and calculations, please refer to the Technical Information Library found on our web site: www.parkermotion.com

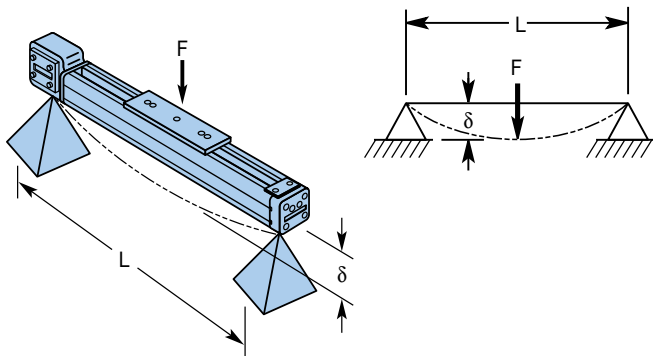

F = Force N
L = Unsupported length mm
 δ = Deflection mm

Deflection Curves

HPLA080

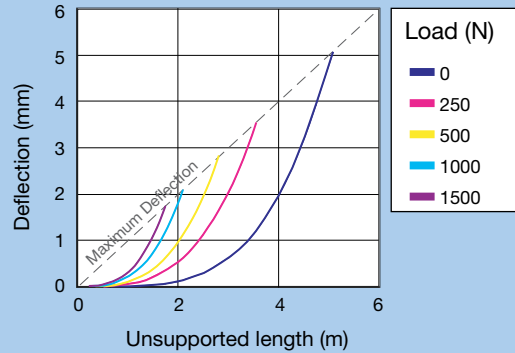

HPLA120

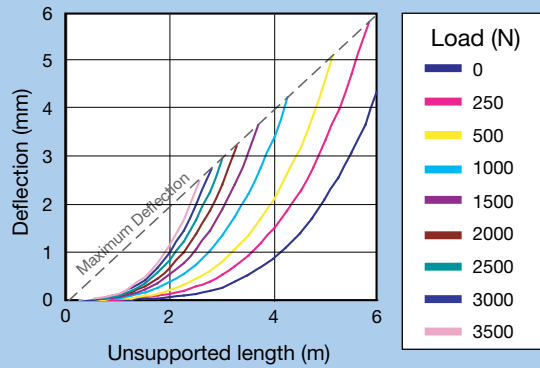

HPLA180

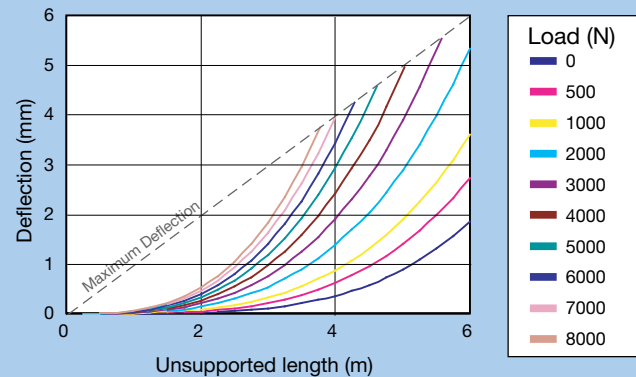



Dual Axis Considerations

When two parallel linear modules are required to form a single axis, the span or distance between each unit determines which type of shaft connection is required. In some cases, a link shaft support bearing might also be required.

Figure A

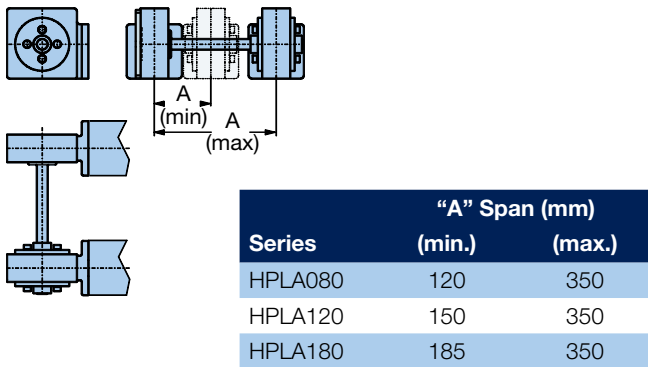

Figure B

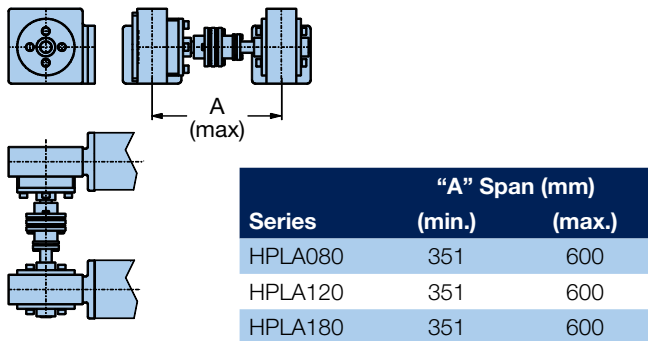
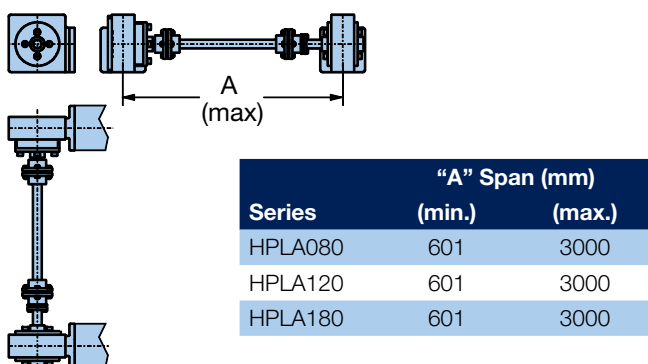
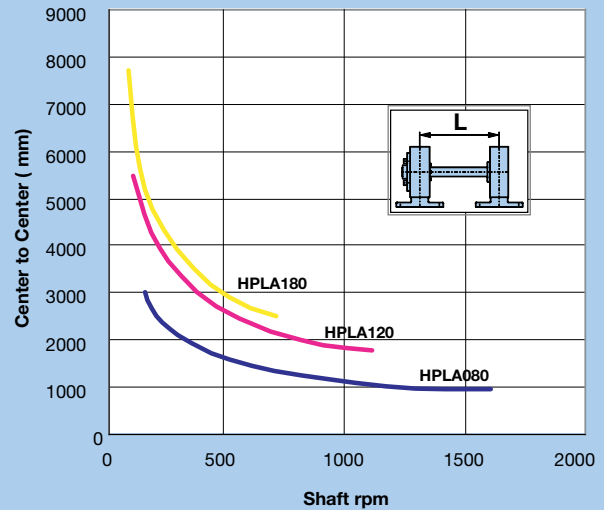

Figure C



The link shaft bearing is used to support the linking shaft of an HPLA dual axis when there is a large center to center distance. This bearing must be used if the critical speed is exceeded with the dual-axis link shaft.

Critical Speed



Linear Velocity

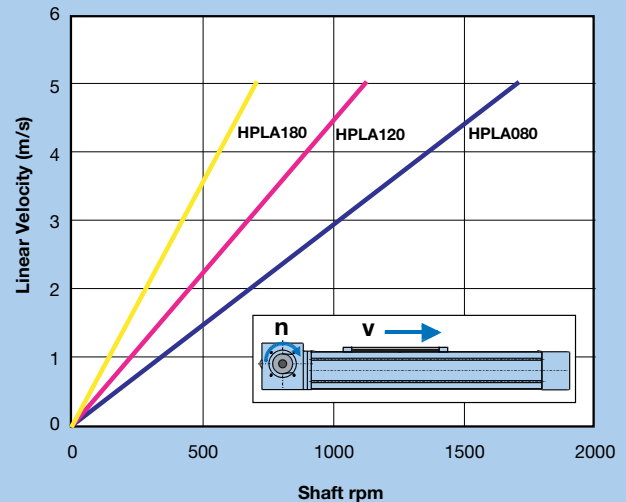

Belt Driven Tables

HPLA080 Drive Unit

Dimensions (mm)

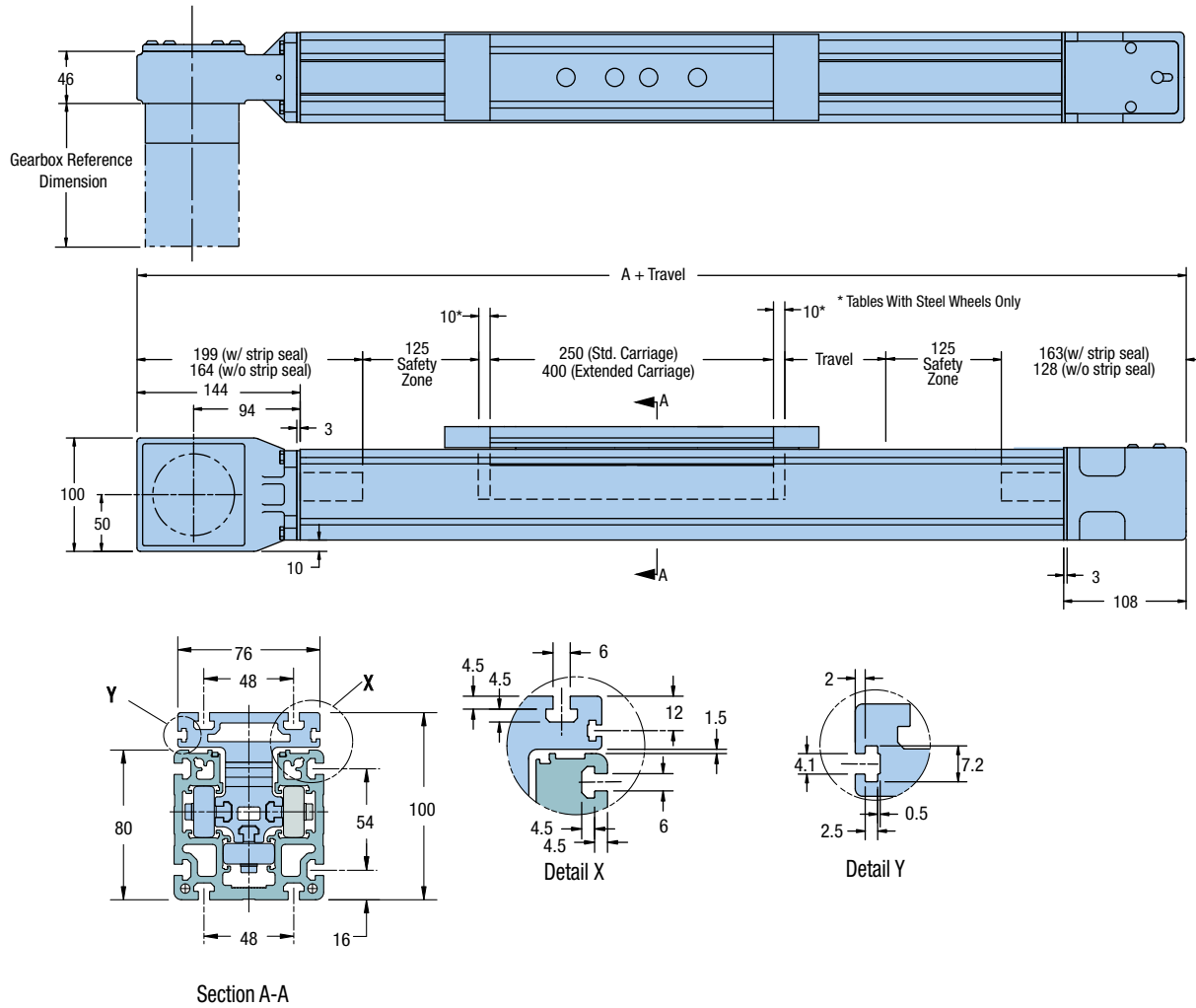

Description	Dimension A (mm)	
	With Strip Seal	Without Strip Seal
Standard Carriage - Polyamide Wheels	862	792
Standard Carriage - Steel Wheels	882	812
Extended Carriage - Polyamide Wheels	1012	942
Extended Carriage - Steel Wheels	1032	962



HPLA120 Drive Unit

Dimensions (mm)

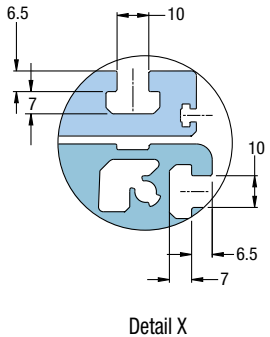
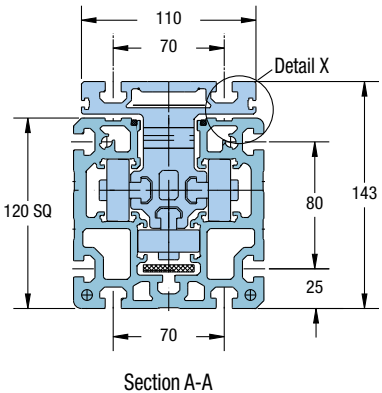
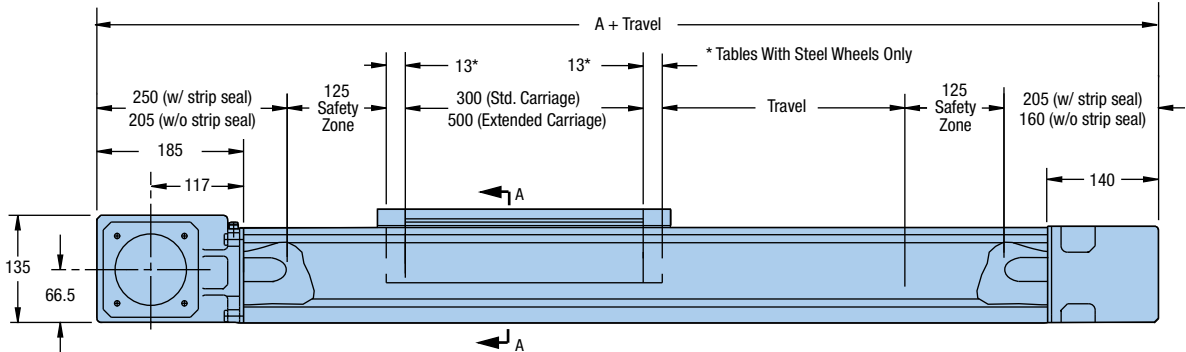
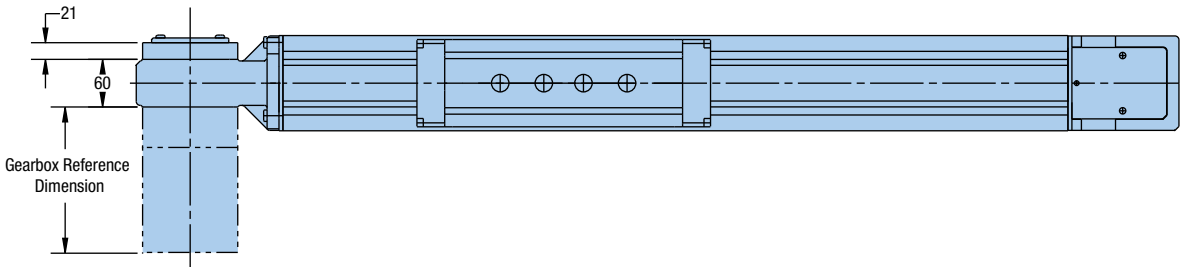

Belt Driven Tables

Description	Dimension A (mm)	
	With Strip Seal	Without Strip Seal
Standard Carriage - Polyamide Wheels	1005	915
Standard Carriage - Steel Wheels	1031	941
Extended Carriage - Polyamide Wheels	1205	1115
Extended Carriage - Steel Wheels	1231	1141



HPLA180 Drive Unit

Dimensions (mm)

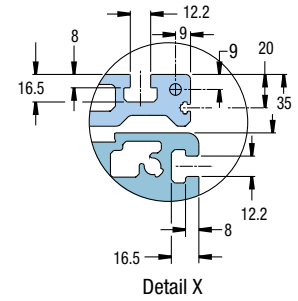
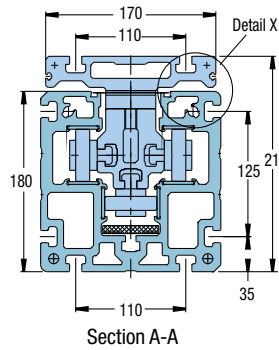
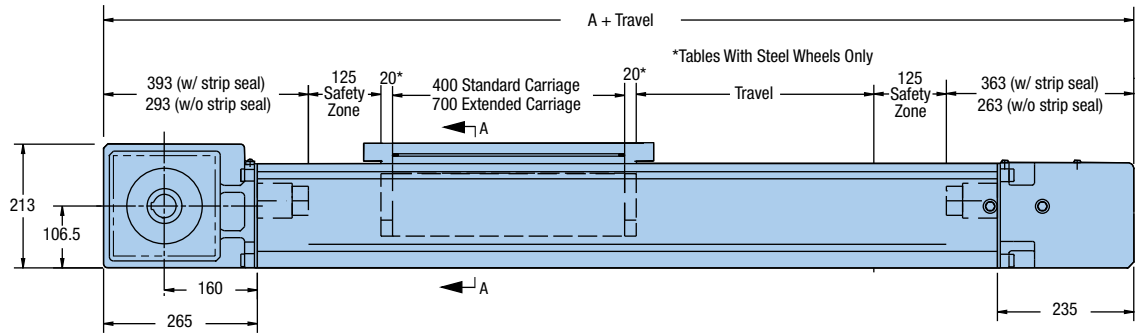
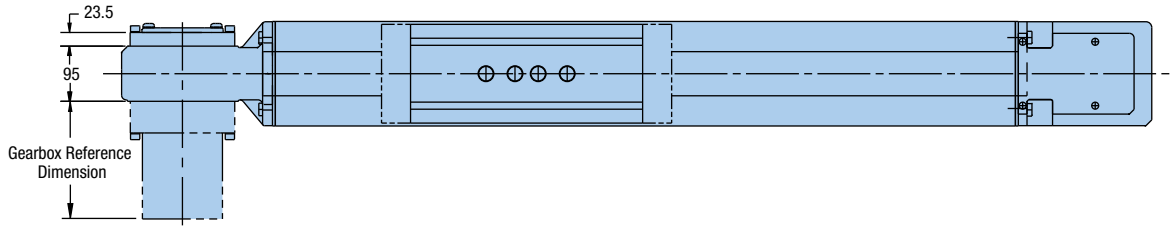

Description	Dimension A (mm)	
	With Strip Seal	Without Strip Seal
Standard Carriage - Polyamide Wheels	1408	1206
Standard Carriage - Steel Wheels	1446	1246
Extended Carriage - Polyamide Wheels	1706	1506
Extended Carriage - Steel Wheels	1746	1546

HPLA180 Rack Drive Unit

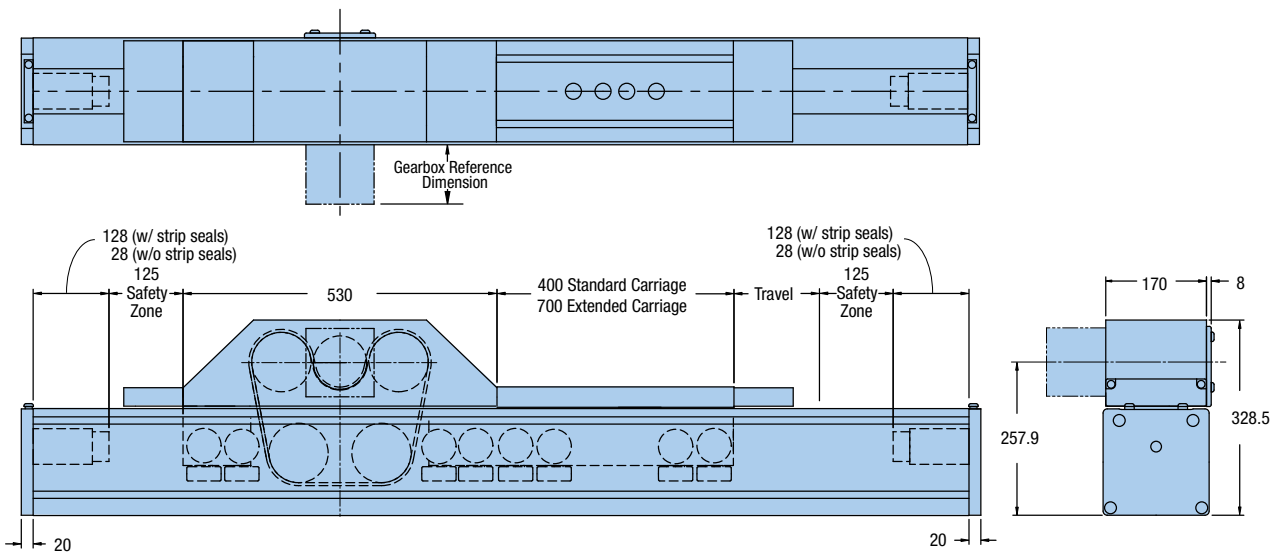



Idler Unit Dimensions

Dimensions (mm)

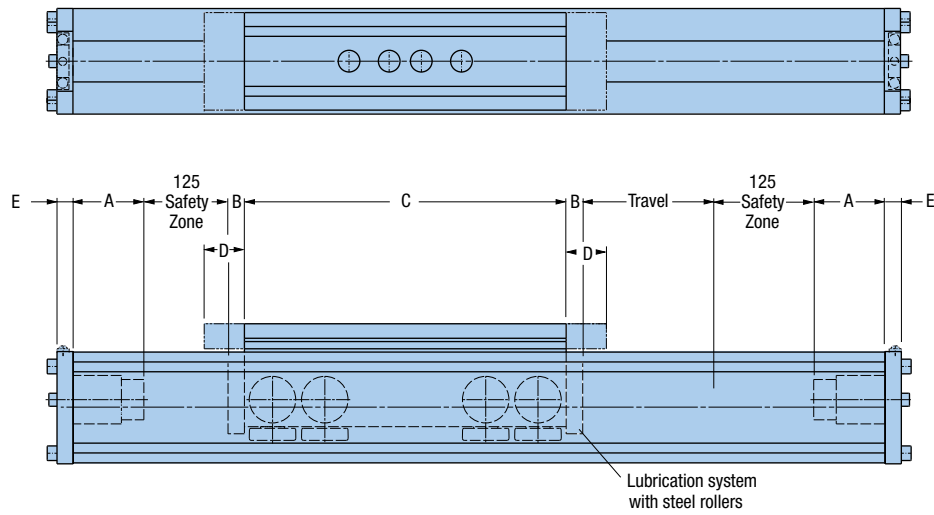

Series	Carriage Length	Wheel Type	Dimensions (mm)									
			With Strip Seal					Without Strip Seal				
			A	B	C	D	E	A	B	C	D	E
HPLA080	Standard	Polyamide	55	-	250	40	10	20	-	250	-	10
HPLA080	Extended	Polyamide	55	-	400	40	10	20	-	400	-	10
HPLA080	Standard	Steel	55	10	250	40	10	20	10	250	-	10
HPLA080	Extended	Steel	55	10	400	40	10	20	10	400	-	10
HPLA120	Standard	Polyamide	65	-	300	50	15	20	-	300	-	15
HPLA120	Extended	Polyamide	65	-	500	50	15	20	-	500	-	15
HPLA120	Standard	Steel	65	13	300	50	15	20	13	300	-	15
HPLA120	Extended	Steel	65	13	500	50	15	20	13	500	-	15
HPLA180	Standard	Polyamide	128	-	400	100	20	28	-	400	-	20
HPLA180	Extended	Polyamide	128	-	700	100	20	28	-	700	-	20
HPLA180	Standard	Steel	128	20	400	100	20	28	20	400	-	20
HPLA180	Extended	Steel	128	20	700	100	20	28	20	700	-	20

Belt Driven Tables

Fill in an order code from each of the numbered fields to create a complete model order code.

① ② ③ ④ ⑤ ⑥ ⑦ ⑧ ⑨ ⑩ ⑪ ⑫ ⑬ ⑭ ⑮

Order Example: HPLA080 D1 B1 T2000 C1 DA1000 S08 F02 G2-05 K24 M98 R1 H1 LH1 E1

① **Series**

HPLA080
HPLA120
HPLA180

② **Drive System**

D0 Idler Unit
D1 Timing Belt Drive, Nominal Thrust, Maximum Life
D2 Timing Belt Drive, Maximum Thrust, Nominal Life
D9 Internal Rack and Pinion (HPLA180 only)

③ **Bearing Option**

B1 Polyamide Rollers
B2 Steel Rollers

④ **Travel**

Tnnnn Specified travel in mm (nnnn = mm)

⑤ **Carriage**

C1 Standard Length Carriage with Load Plate*
C2 Extended Length Carriage with Load Plate*
C3 Standard Length Carriage with Clamping Bar*
C4 Extended Length Carriage with Clamping Bar*

* See photos below.

⑥ **Link Shaft Option**

DA0000 No Link Shaft - Single Axis or Idler Unit
DAAnnn Double Unit, Specify Center to Center Distance (mm)

⑦ **Drive Shaft Configuration**

S00 No Shaft, Idler Unit
S01 Unsupported Pulley, Flange Left
S02 Unsupported Pulley, Flange Right
S03 Supported Pulley, Flange Left
S04 Supported Pulley, Flange Right
S05 Supported Pulley, Shaft Option, Left
S06 Supported Pulley, Shaft Option, Right
S07 Supported Pulley, Shaft Option, Both
S08 Supported Pulley, Flange Left, Shaft Right
S09 Supported Pulley, Flange Right, Shaft Left

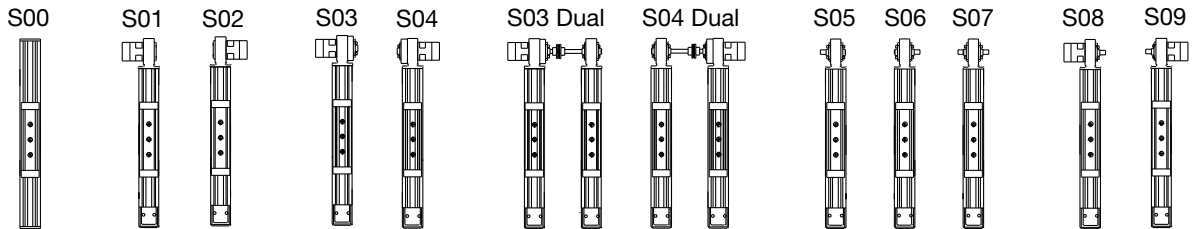

Load Plate carriage option

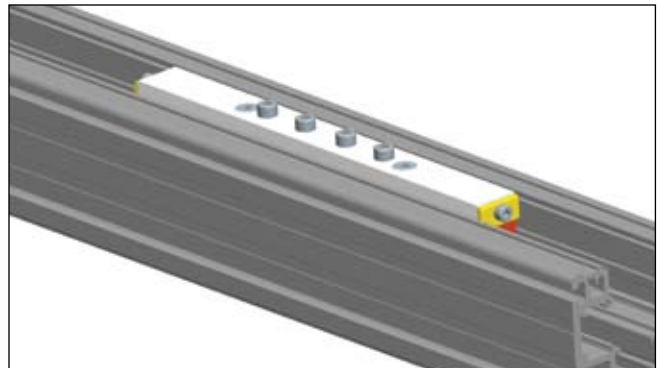

Clamping Bar carriage option



8 Drive Housing Flange

F00	No Flange
F01	GTN070 Flange (HPLA080 only)
F02	GTN090 Flange (HPLA080 and HPLA120 only)
F03	GTN115 Flange (HPLA120 & HPLA180 only)
F04	GTN142 Flange (HPLA180 only)
F06	PEN090 Flange (HPLA080 only)
F07	PEN115 Flange (HPLA080 and HPLA120 only)

9 Gearbox Option

G0-00	No Gearbox
G01-nn	GTN070*
G02-nn	GTN090*
G03-nn	GTN115*
G04-nn	GTN142*
G06-nn	PEN090**
G07-nn	PEN115**

*Single stage ratios: 3, 4, 5, 8, 10; Dual stage ratios: 12, 15, 16, 20, 25

**Single stage ratios: 3, 4, 5, 8; Dual stage ratios: 9, 12, 15, 16, 20, 25

10 Motor Kit Option

K00	No Flange
K20	NEMA23 stepper, 1/4" shaft
K21	BE23
K22	MPM66 (metric)
K23	SMN60, MPM72 (metric), N070, J070
K24	SMN82, MPM89 (metric), N092, J092
K25	NEMA34 stepper, 3/8" shaft
K26	BE34
K27	SMN100
K28	NEMA42 stepper, 5/8" shaft
K29	MPM114x (x = 0, 1 metric)
K30	SMN115, MPM114x (x = 2, 3 metric)
K31	SMN152, MPM142 (x = 0, 1, 2 metric)
K32	MPM142x (x = 3, 4 metric)
K33	MPM190x (x = 0, 1, 2 metric)
K34	MPP092x motor kit

11 Motor Mount Option

M00	No Motor
M98	Mount Parker Motor
M99	Mount Customer Motor (Consult Factory)

12 Environmental Option

R1	Standard preparation with strip seal ¹
R2	Standard preparation with no strip seal
R3	Corrosion resistant preparation with strip seal ^{1, 2}
R4	Corrosion resistant preparation with no strip seal ²

¹ C1, C2 Carriage Load Plate Only

² B1 Bearing Option Polyamide Rollers Only

13 Mounting Orientation

H1	Carriage Up
H2	Carriage Down
H3	Carriage on Side, Drive Station Up
H4	Carriage on Side, Drive Station Down

14 Limit/Home Switch Option*

LH0	No Limit Switch Assembly
LH1	Three Mechanical Switches
LH2	Two Mechanical Switches, One Proximity (NPN)
LH3	Three NPN Prox Switches, 10-30 VDC
LH4	Three PNP Prox Switches, 10-30 VDC

*C1, C2 Carriage Load Plate Only

15 Linear Encoder

E1	Without Linear Encoder
E5	5.0 Micron Resolution, Magnetic Type
E7	Sine Cosine Output, Magnetic Type

*C1, C2 Carriage Load Plate Only

HLE-RB Series Belt Driven Linear Modules

Features

- Standard travel up to 7.9 meters*
- Load Capacities up to 600 kg
- ± 0.2 mm positional repeatability
- Timing belt and pulley drive mechanism for fast, accurate positioning
- Roller wheel bearings for smooth high speed linear motion
- IP30 strip seal

*Longer travels available with splice kits.

The HLE-RB linear modules are ideal as single axis products or as components for high speed multi-axis gantries. With thousands of units in operation worldwide the HLEs are proven performers offering long life and trouble-free operation.

Construction

The HLE Linear Module consists of a lightweight carriage which can be precisely positioned within an extruded aluminum housing by a timing belt and pulley drive system. The housing, constructed from extruded aluminum with a square cross sectional geometry, demonstrates excellent deflection characteristics.

The protective anolite coating provides durability as well as an attractive silver appearance. It includes T-slots along its entire length for flexible mounting. The drive mechanism is a zero backlash steel reinforced timing belt. The tension station, conveniently located at the end of the unit provides for quick and easy belt adjustment. The drive station is designed to accept planetary gear reducers as well as a wide variety of servo and stepper motors. The bearing system for the RB models is comprised of three rows of roller wheels integral to the carriage which are guided by extruded tracks within the housing.



Proven Technology

Proven in numerous applications, the HLE-RB series offers the following advantages:

- Low running friction
- Low particle generation (clean room suitability to class 100)
- Low wear
- Low maintenance
- Quiet operation
- High efficiency
- Long service life
- High dynamic performance due to low-mass, play-free wheels
- Minimal preventative maintenance required
- T-slots integrated on all sides of the profile for mounting attachments or for use as a cable duct
- Timing belts can be replaced without removing load attachment plate
- Multiple configuration options due to T-slots available on both the profile and load plate

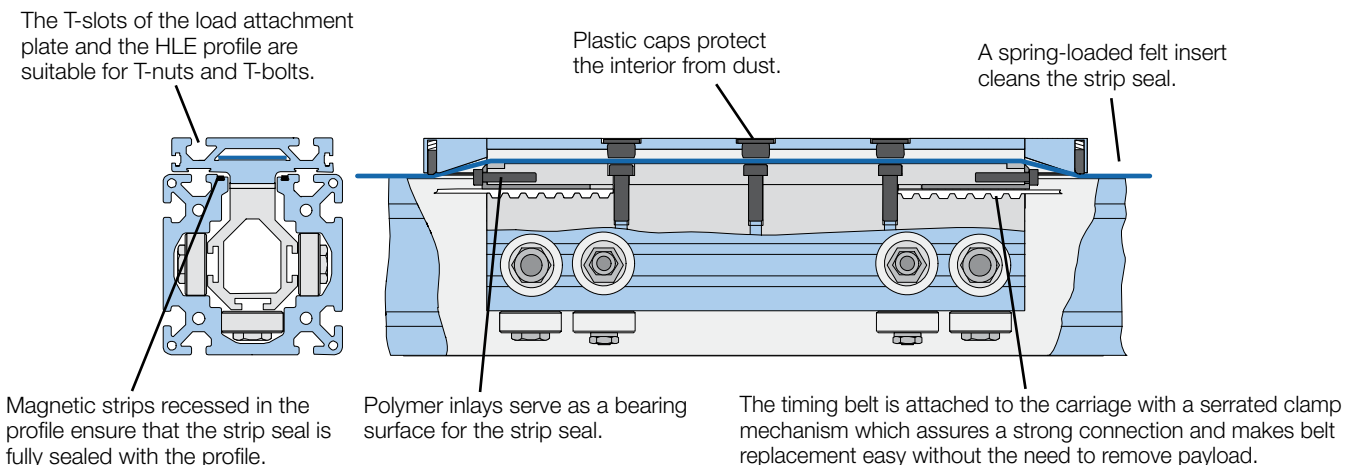



Typical Fields of Application

As part of advanced, cost-effective construction of machines and handling systems:

- Materials handling: palletizing, depalletizing, feeding, part removal
- Cleanroom technology: wafer transport, wafer coating
- Warehouse technology: parts picking, storage and retrieval
- Machine tool automation: workpiece loading and unloading, tool changing
- Construction: formwork, placing reinforcing steel bars in concrete
- Process engineering: painting, coating, bonding
- Testing technology: guiding ultrasonic sensors, laboratory equipment
- Textile machinery: crosscutting, slitting and stacking, quilting, seam stitching

Optional Features

- Direct mounting for planetary gear reducers
- Adjustable “end of travel” limit switches and “home” position sensor
- Clean room preparation option
- Cable carrier systems
- Performance matched Parker servo systems
- Structural components for vertical and multi-axis mounting
- Toe clamps and hardware for fast and easy mounting
- External bumpers
- Link shafts and support bearings for dual axis units
- Splice plates for extending travels beyond length available in a single profile

See pages 272-276 for available options and accessories.

Housing
Lightweight and self-supporting aluminum profiles are offered in three sizes:
HLE60: 60 x 60 mm
HLE100: 100 x 100 mm
HLE150: 150 x 150 mm
T-slots are provided for mounting the linear unit itself, applying additional components and accessories, or combining multiple HLEs. T-slots with plastic covers provide a simple cable conduit.

Load Attachment Plate
Load attachment plates are available for every type of carriage. With integral T-slots or tapped with holes in a standard mounting pattern, they allow easy mounting of your load to the carriage of the HLE. Multiple HLEs can easily be mounted together by using standard clamping profiles. Tripping plates are mounted to the side of the load attachment plate to activate home or end of travel switches mounted to the side of the HLE. For special applications, the load plates can be designed to customer specified requirements.

Drive Station
Rigid cast housing with standard flanges for a variety of gearboxes. The drive stations are designed to accept planetary and worm gear reducers or provide different shaft outputs for driving the HLE.

Drive Belt
A zero backlash, steel reinforced timing belt provides high speed, high acceleration and good bidirectional repeatability.

Carriage
Roller bearing wheels are installed on three sides of the carriage to provide smooth linear motion and support. The wheels are positioned to evenly distribute the load across the length of the carriage. Eccentric bearing wheel bushings are adjusted to eliminate play on all sides of the carriage. Due to a low coefficient of friction, the carriage design provides a high mechanical efficiency and long service life. The carriages are available in standard and extended lengths. Special carriage lengths and linear units with multiple carriages are available for custom applications.

Roller Bearing
Each wheel consists of a lubricated and sealed radial ball bearing to reduce friction and maintenance. The bearing is enclosed within a tough polyamide tread to reduce noise and provide long service life.

IP30 Strip Seal
Magnetically attached stainless steel seal strip (not shown) provides environmental protection to interior components.

Tensioning Station
“Easy access” tensioning bolts allow external adjustment of belt tension.

Belt Driven Tables

HLE-RB Series Specifications

Characteristic	Units	HLE60-RB		HLE100-RB		HLE150-RB	
Unit Weight (basic unit without stroke)							
Standard Carriage, NL	kg (lb.)	2.28	(5.03)	12.70	(28.00)	31.20	(68.80)
Extended Carriage, VL	kg (lb.)	3.98	(8.77)	15.80	(34.84)	38.50	(84.89)
Carriage Weight							
Standard Carriage, NL	kg. (lb)	0.8	(1.76)	2.80	(6.17)	7.30	(16.10)
Extended Carriage, VL	kg. (lb)	1.3	(2.87)	4.40	(9.70)	11.50	(25.36)
Weight per meter of additional length	kg/m (lb/ft)	3.62	(2.43)	10.00	(6.72)	21.10	(14.18)
Moment of Inertia (related to the drive shaft)							
Standard Carriage, NL	kg-cm ² (lb-in ²)	3.07	(1.05)	24.60	(8.41)	123.30	(42.17)
Extended Carriage, VL	kg-cm ² (lb-in ²)	4.81	(1.64)	36.40	(12.45)	183.60	(62.79)
Travel and Speed							
Maximum Speed ⁽¹⁾	m/s (in/s)	5	(120)	5	(200)	5	(200)
Maximum Acceleration ⁽¹⁾	m/s ² (in/s ²)	10	(393)	10	(393)	10	(393)
Maximum Travel ⁽²⁾ —standard carriage, NL	m (in)	4.0	(160)	6.2	(244)	7.9	(311)
Maximum Travel ⁽²⁾ —extended carriage, VL	m (in)	3.8	(149)	6.0	(238)	7.7	(305)
Geometric Data							
	mm (in)	57.1	(2.25)	100.0	(3.94)	150.0	(5.91)
Cross Section, Square	cm ⁴ (in ⁴)	55.8	(1.34)	383.0	(9.20)	1940.0	(46.61)
Moment of Inertia Ix	cm ⁴ (in ⁴)	56.2	(1.35)	431.0	(10.35)	2147.0	(51.58)
Moment of Inertia Iy	N/mm ²	0.72 x	(0.1044 x	0.72 x	(0.1044 x	0.72 x	(0.1044 x
Moment of Elasticity	(lb/in ²)	10 ⁵	10 ⁸)	10 ⁵	10 ⁸)	10 ⁵	10 ⁸)
Pulley Data, Torques, Forces							
Travel Distance per Revolution	mm/rev (in/rev)	125	(4.92)	170	(6.69)	240	(9.45)
Pulley Diameter	mm (in)	39.8	(1.57)	54.1	(2.13)	76.4	(3.01)
Maximum Drive Torque ⁽³⁾	Nm (lb-in)	8.87	(78.5)	40.0	(354.0)	108.0	(955.9)
Maximum Belt Traction ⁽³⁾ (effective load)	N (lb)						
Repeatability ⁽⁴⁾	mm (in)	±0.2	(±0.008)	±0.2	(±0.008)	±0.2	(±0.008)

For the following deviations from the above standards, please contact Parker engineering:

- (1) Greater speeds and accelerations may be achieved.
- (2) Splicing possible for longer travel distances. This may cause reductions in effective load, drive torque, speed, acceleration, and repeatability. Consult factory for strip seal availability on spliced units.
- (3) Increased timing belt tension required.
- (4) Nominal value - component dependent. For improved repeatability consult factory.

Linear Actuator Size Comparison

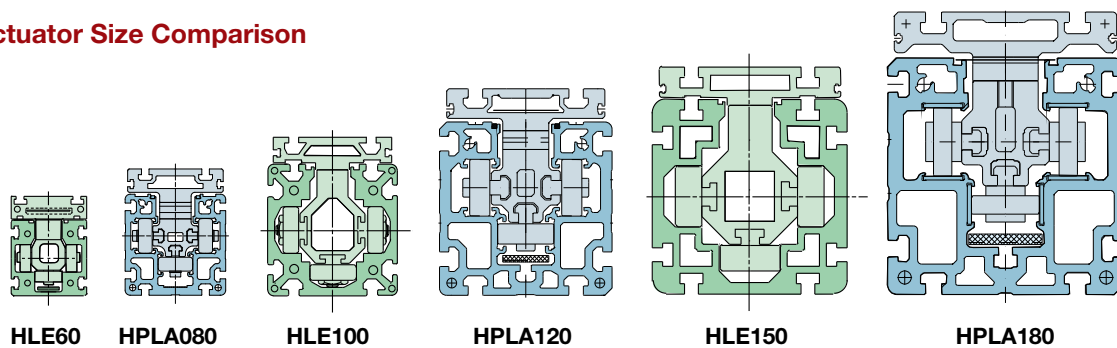



Load-Bearing Capacity of Carriage and Timing Belt

Forces and Moment Loads

The forces and moments that the carriage is capable of transferring are speed-dependent. The curves shown in the graphs apply to a standard carriage (S). With the extended carriage (E), all the values apart from F_x (load-bearing capacity of timing belt) can be doubled if the load is applied equally to both halves of the carriage or distributed uniformly along its entire length.

The curves show the maximum load-bearing capacity of a carriage in one direction of force or torque. If several loads are applied in different directions, the values given by the curves must be derated, i.e. the load or speed should be reduced if necessary.

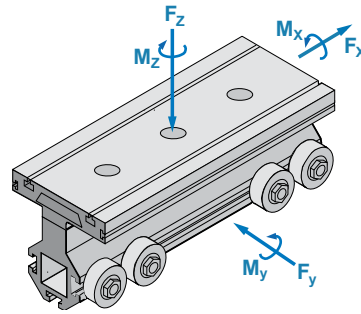

“DimAxes” software is available for determination of precise carriage loading.

Visit www.parkermotion.com to request a Gantry Robot CD.

Load-Bearing Capacity Timing Belt (F_x)

HLE60-RB

Drive Option	Transferrable Thrust Force (n)	
	Nominal Belt Tension (81,000 km life)	Maximum Belt Tension (46,000 km life)
Supported Pulley (SP19 - SP30)	500	-

HLE100-RB

Drive Option	Transferrable Thrust Force (n)	
	Nominal Belt Tension (81,000 km life)	Maximum Belt Tension (46,000 km life)
GTN115	925	1115
GTN090, PEN115	675	900
PEN090	500	665

HLE150-RB

Drive Option	Transferrable Thrust Force (n)	
	Nominal Belt Tension (85,000 km life)	Maximum Belt Tension (37,000 km life)
GTN142	1700	2235
GTN115	1515	2015
PEN115	675	900

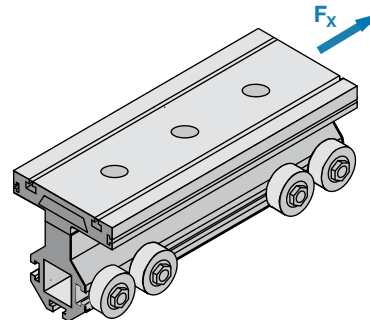

Belt Driven Tables

HLE-RB Series – Force and Moment Loads

Load-Bearing Capacity

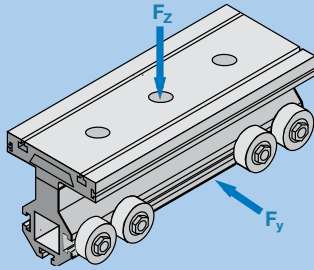

HLE60-RB

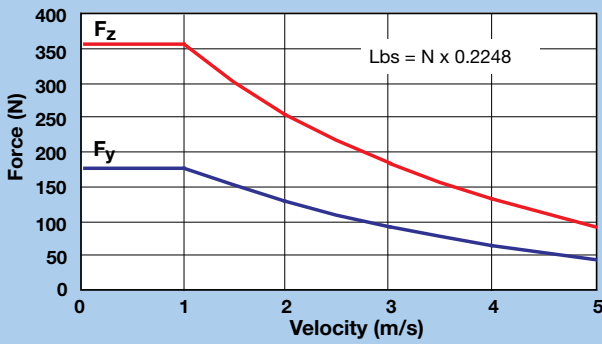

HLE100-RB

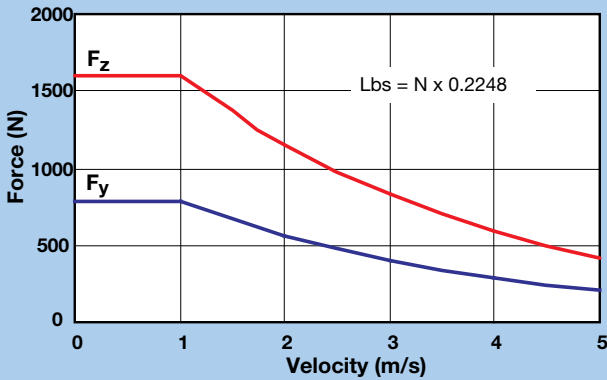

HLE150-RB

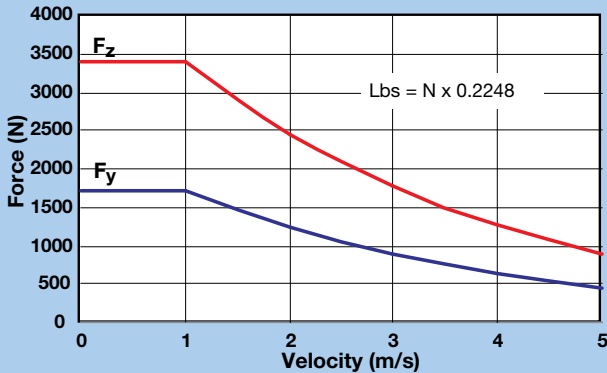

Maximum Permissible Moment Load

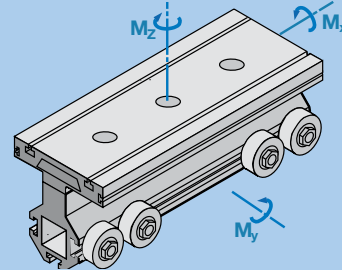

HLE60-RB

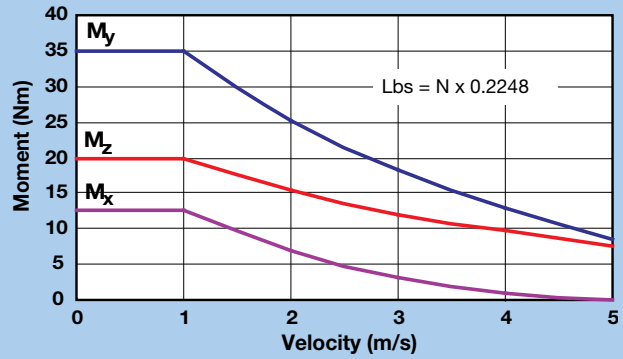

HLE100-RB

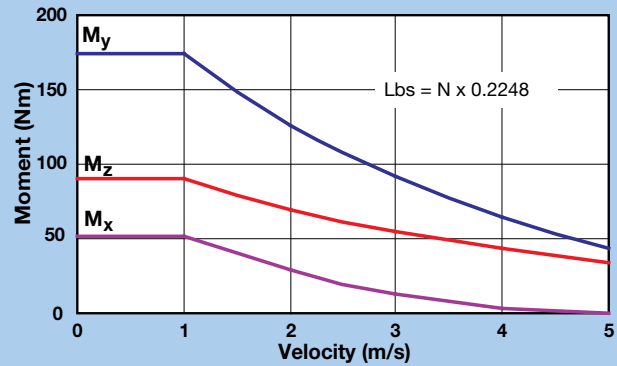

HLE150-RB

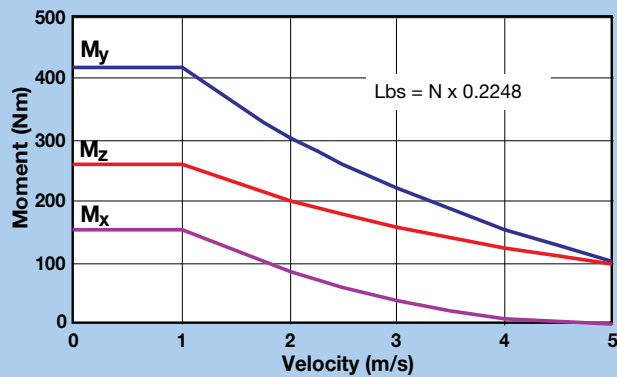



HLE-RB Deflection Characteristics

The HLE deflection curves can be used for determining the deflection based on the profile length and the application load weight. Applications requiring high acceleration forces can place a severe strain on the system stability. In these cases, a solid substructure may be required with the HLE product being supported at frequent intervals.

These deflection curves illustrate the deflection δ , based on the HLE profile being simply supported at both ends. The graphs take into consideration the self deflection due to the weight of the profile, along with the load to be transported. The maximum deflection cannot be exceeded. If the maximum deflection is exceeded based on your application parameters, then additional supports are required. Alternatively, the next larger profile size may be considered. For deflection formulas and calculations, please refer to the Technical Information Library found on our web site www.parkermotion.com

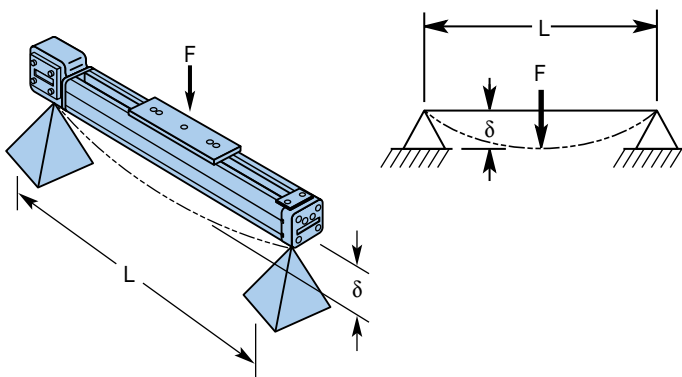

F = Force N
 L = Unsupported length mm
 δ = Deflection mm

Deflection Curves

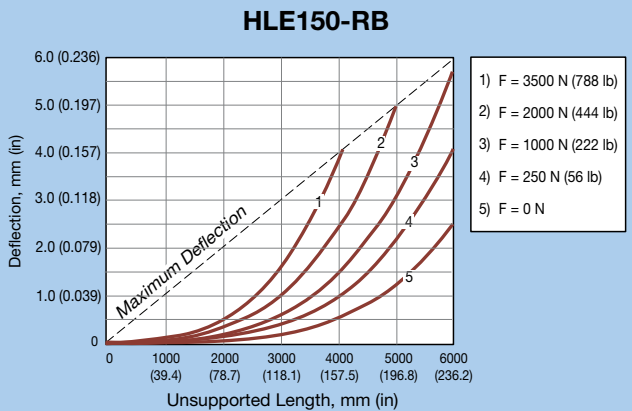
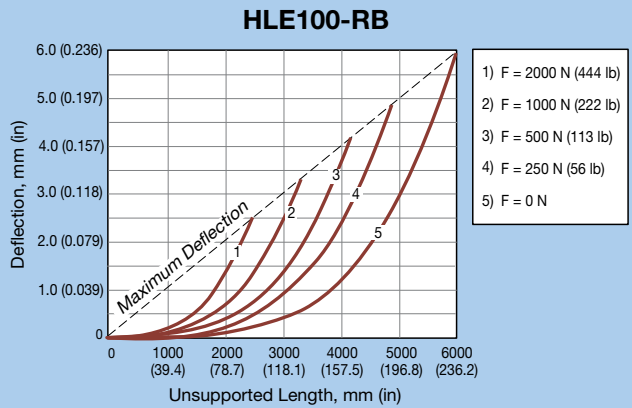
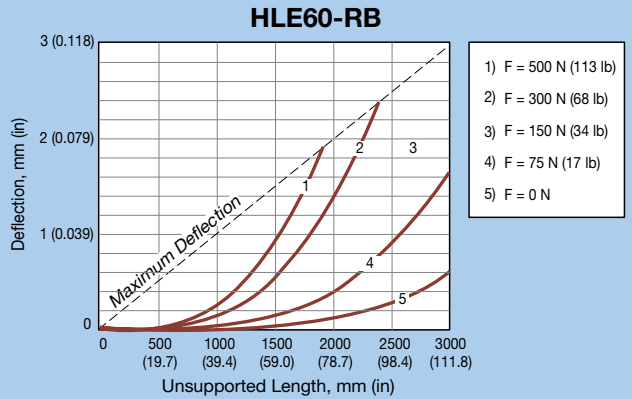

Belt Driven Tables



Dual Unit Axis Considerations

When two parallel linear modules are required to form a single axis, the span or distance between each unit determines which type of shaft connection is required. In some cases, a link shaft support bearing might also be required.

The link shaft bearing is used to support the linking shaft of an HLE dual axis when there is a large center to center distance. This bearing must be used if the critical speed is exceeded with the dual-axis link shaft.

Figure A

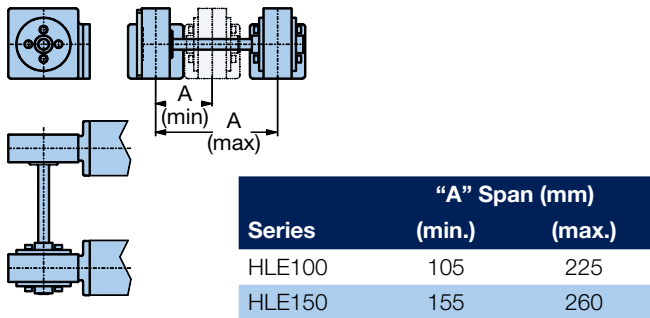

Figure B

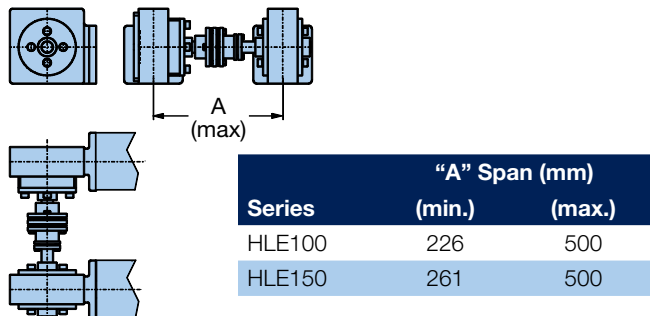
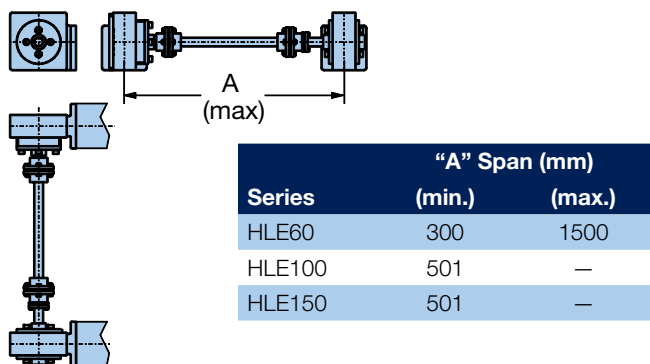
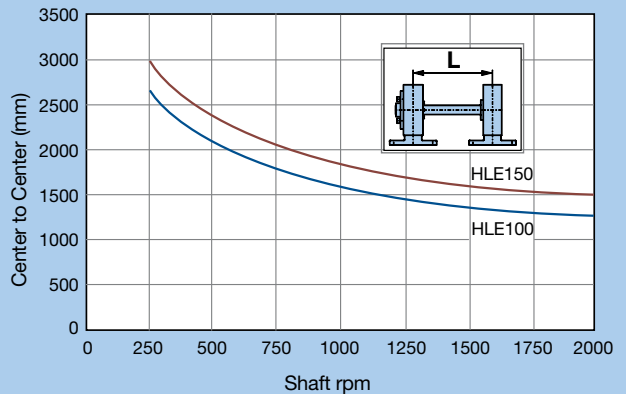

Figure C



Critical Speed*



Linear Velocity

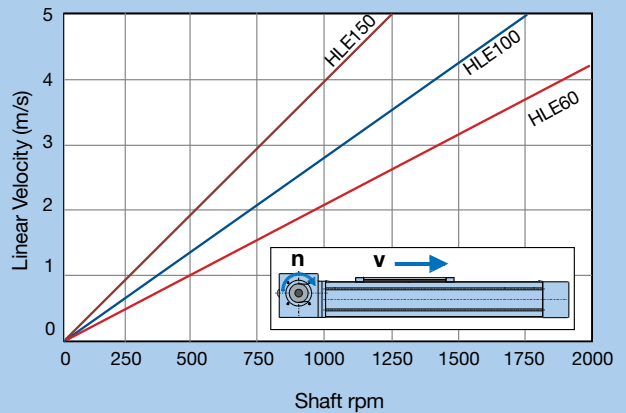

*HLE60 Critical speed is above charted 2000 RPM.



HLE60-RB with PV60 Direct Drive

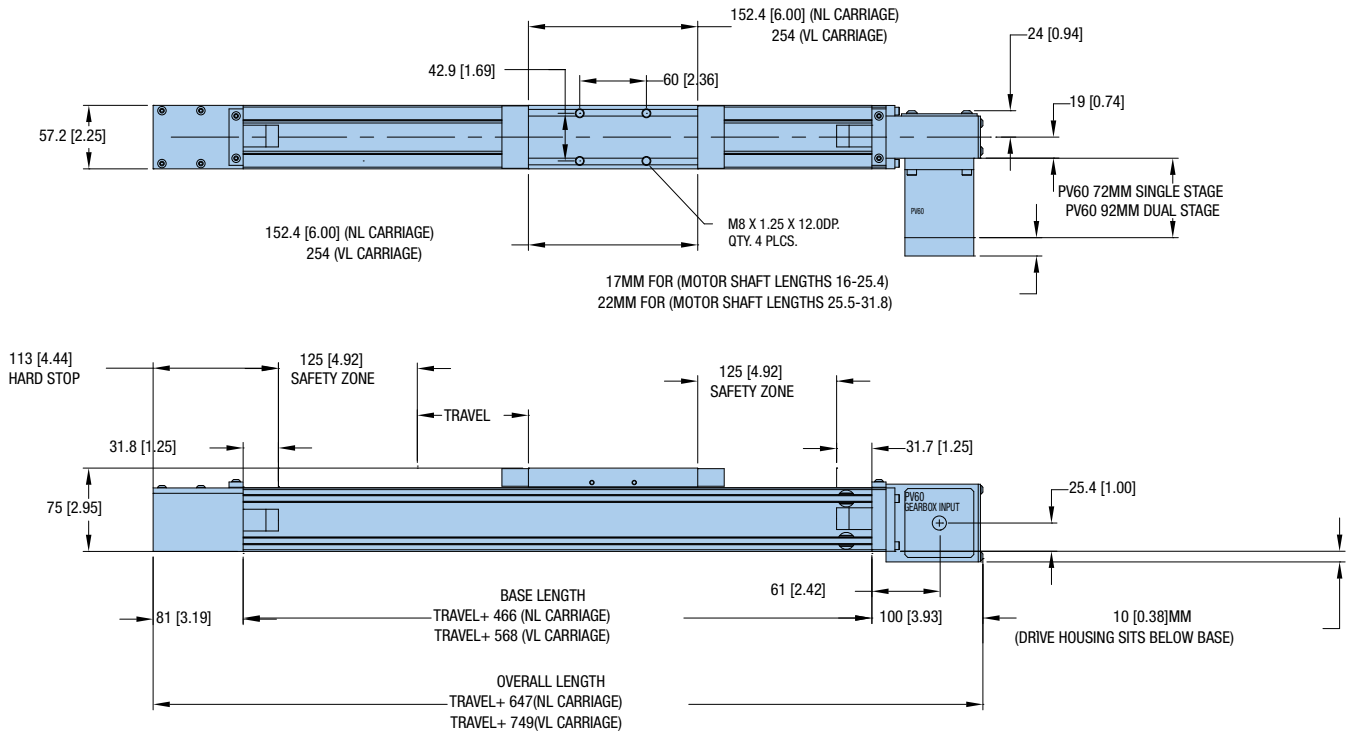

HLE60-RB Drive with Motor Block

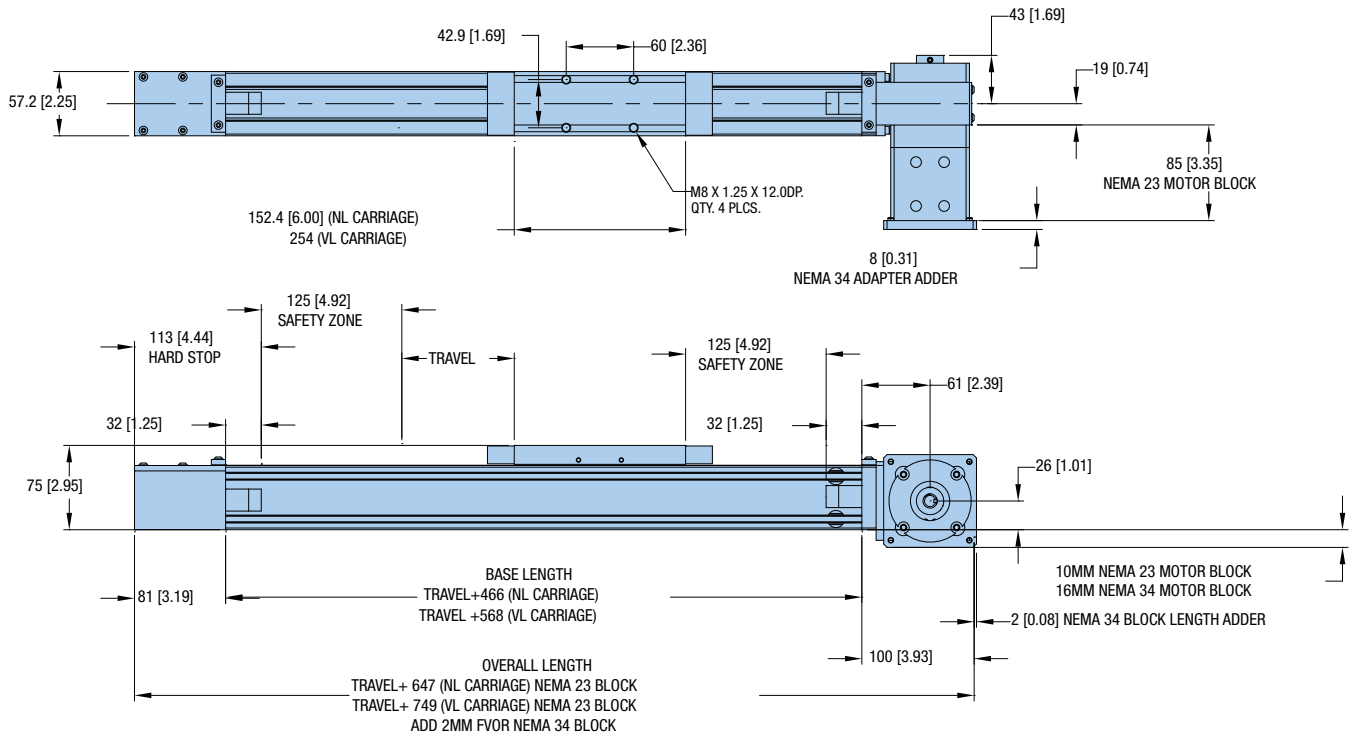

Belt Driven Tables

HLE60-RB Idler

Dimensions (mm)

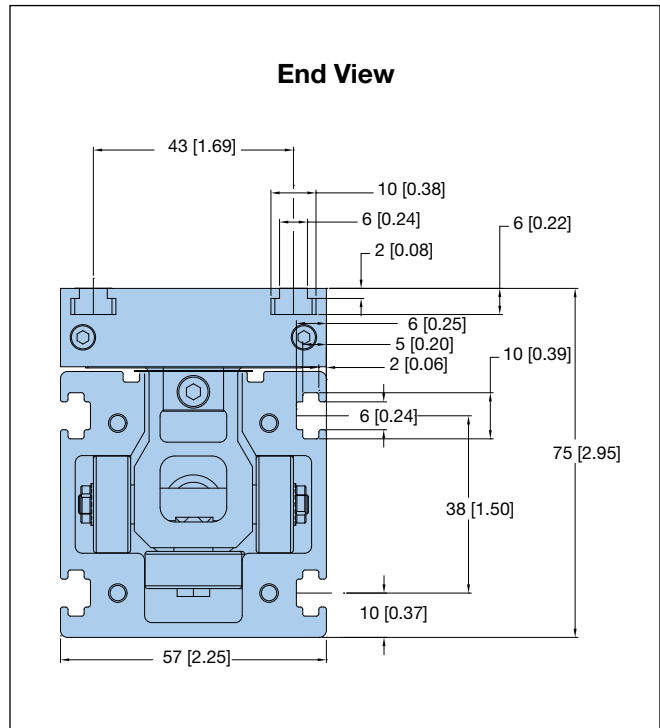
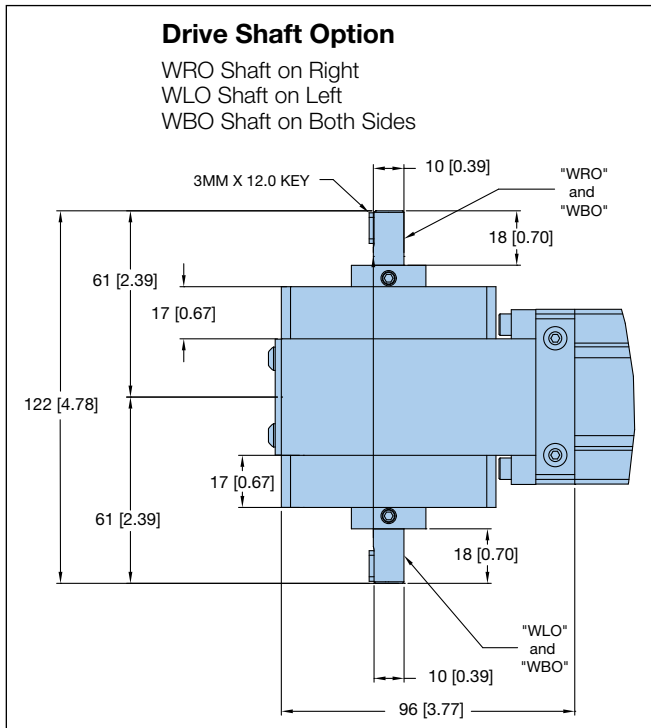
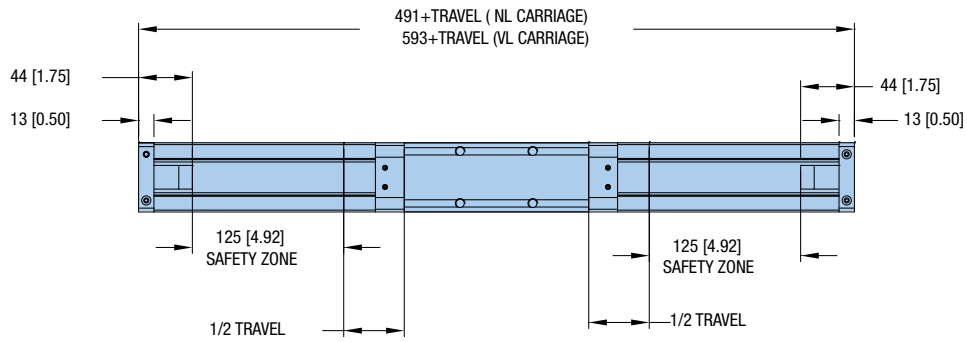



HLE100-RB Drive

Dimensions (mm)

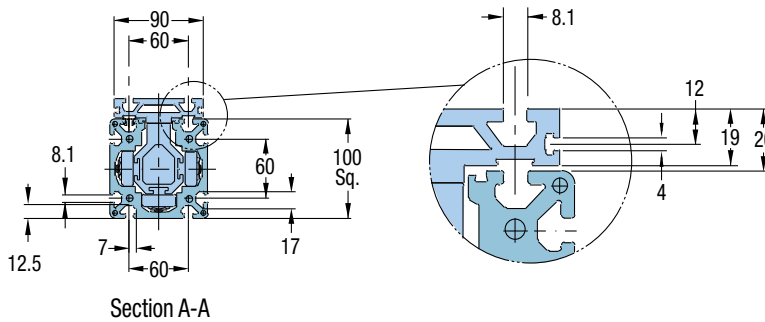
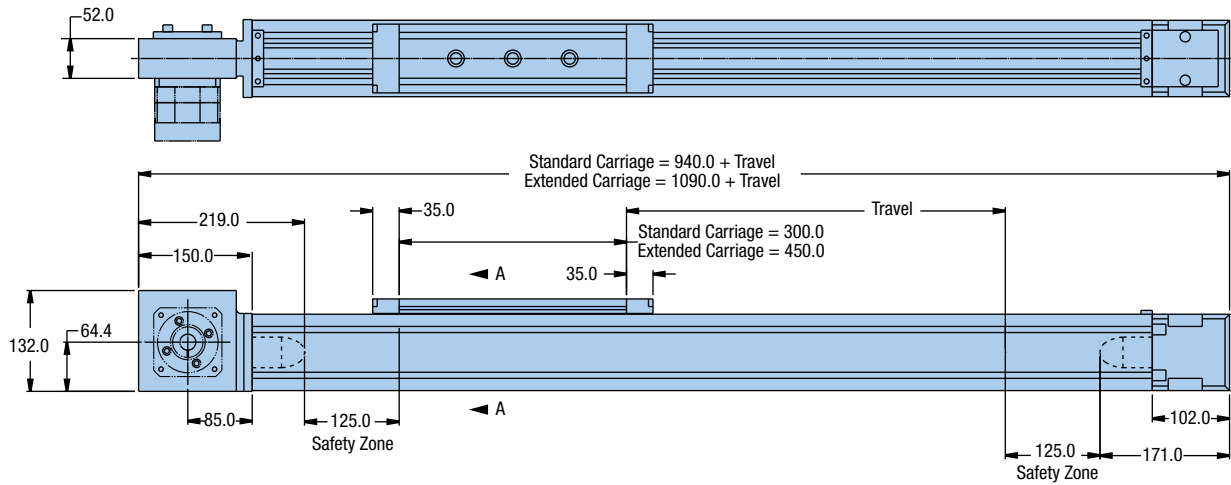

Drive Shaft Option

- WRO Shaft on Right
- WLO Shaft on Left
- WBO Shaft on Both Sides

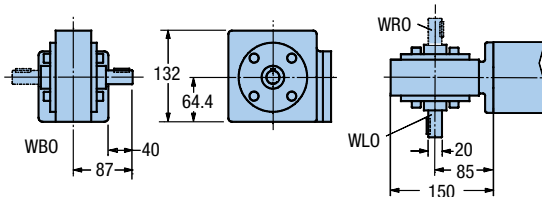

HLE100-RB Idler

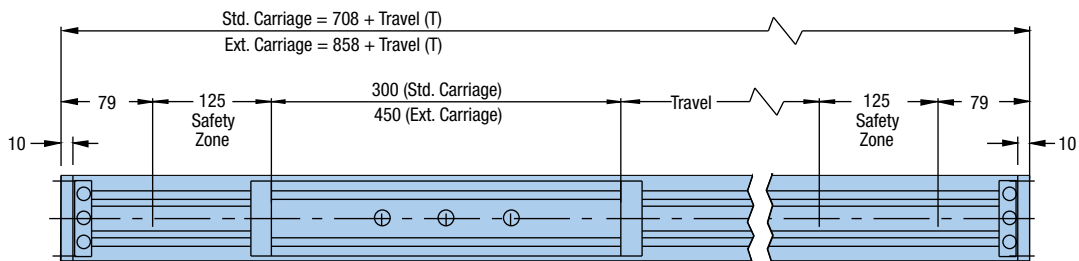

HLE150-RB Drive

Dimensions (mm)

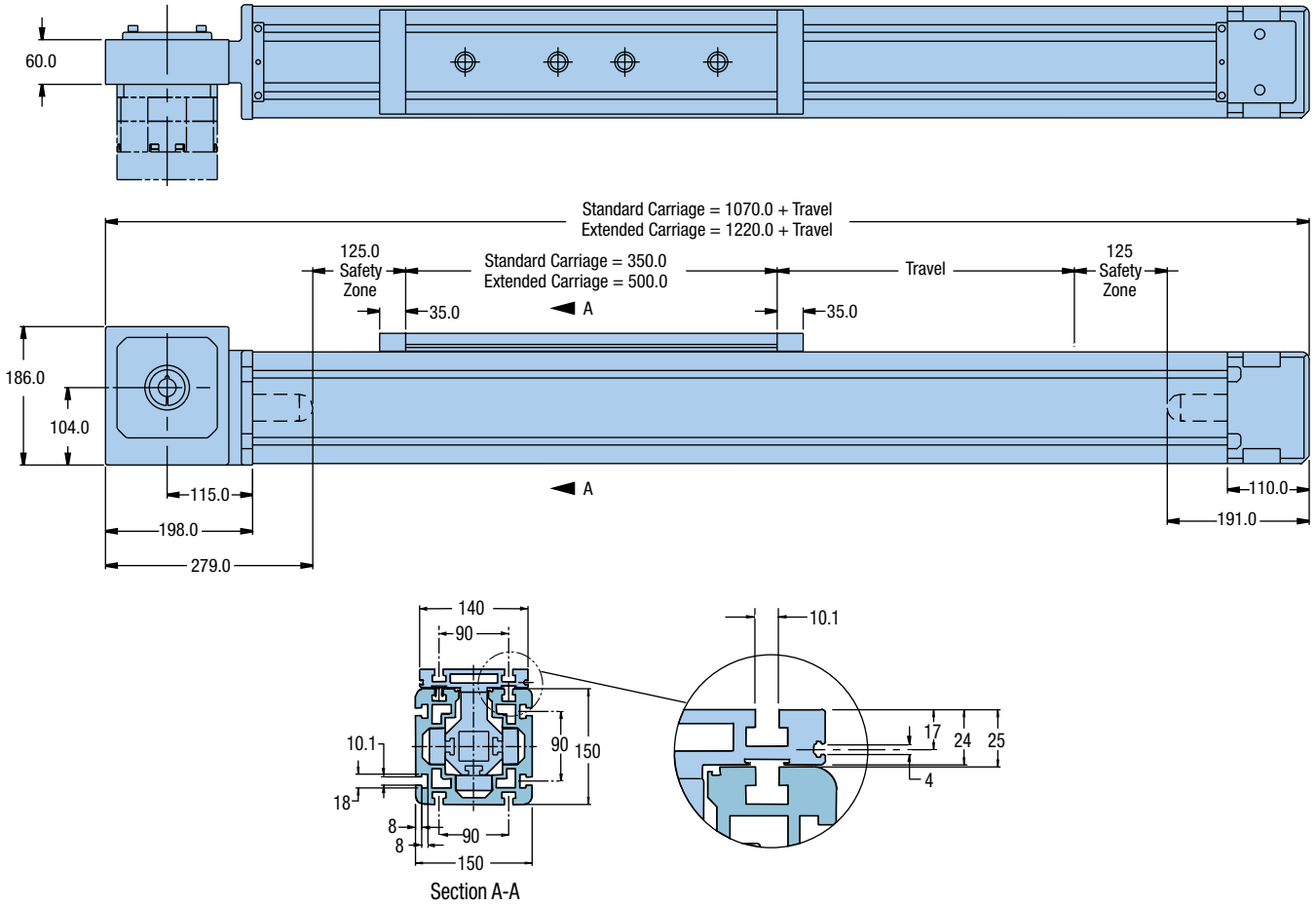

Drive Shaft Option

WRO Shaft on Right
WLO Shaft on Left
WBO Shaft on Both Sides

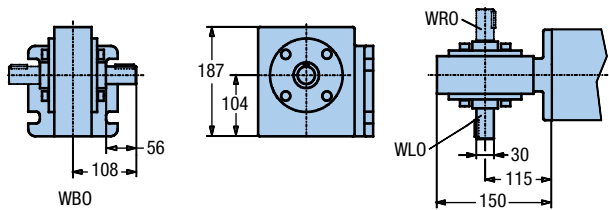

HLE150-RB Idler

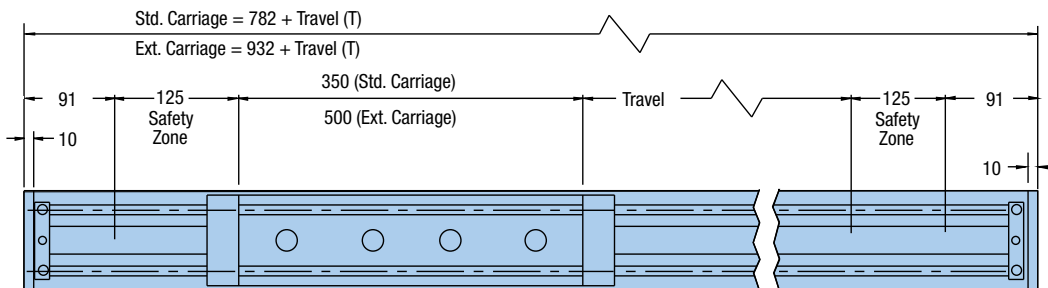



Fill in an order code from each of the numbered fields to create a complete model order code.

- ① ② ③ ④ ⑤ ⑥ ⑦ ⑧ ⑨ ⑩ ⑪ ⑫ ⑬

Order Example: HLE060 RB NL E 1000 DA0000 MBL SP5 G1205 H1 K24 ZA LH0

① **Series**
HLE060

② **Bearing Type**
RB

③ **Carriage Type**
NL Standard Carriage
VL Extended Carriage

④ **Unit Type**
M Idler
D Dual Axis Unit
E Single Axis Unit

⑤ **Travel Length**
nnnn nnnn=mm (3000 mm max for NL carriage;
2900 mm max for VL carriage)

⑥ **Drive Shaft Option - Center to Center**
DA0000 No Drive Shaft - Single Axis or Idler Unit
DAnnnn (nnnn=mm) Dual Axis Center to Center
(200 mm min; 1500 mm max)
DCnnnn (nnnn=mm) Dual Axis with Covered Link Shaft Center
to Center (200 mm min; 1500 mm max)

⑦ **Shaft Configuration Options**
WOO No Shaft, Idler Unit
ARO Gearhead Right
ALO Gearhead Left
ARW Gearhead Right Shaft Left
ALW Gearhead Left Shaft Right
WLO Shaft Left
WRO Shaft Right
WBO Double Shaft
WBO Motor Block Left
MBR Motor Block Right
MLW Motor Block Left, Shaft Right
MRW Motor Block Right, Shaft Left
DAL Double Axis Gearhead, Drive Left
DAR Double Axis Gearhead, Drive Right
DML Double Axis, Motor Block Left
DMR Double Axis, Motor Block Right

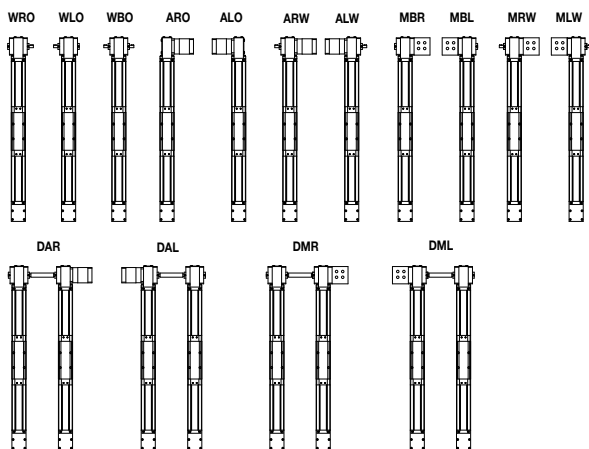

⑧ **Drive Station Interface**
SP19 Drive Housing For PV60-FN
SP20 Idler Unit
SP21 No Motor Block
SP22 Motor Block NEMA 23 with 0.375" Bore Coupling
SP23 Motor Block NEMA 34 with 0.25" Bore Coupling
SP24 Motor Block NEMA 34 with 0.375" Bore Coupling
SP25 Motor Block NEMA 34 with 0.50" Bore Coupling
SP28 Motor Block NEMA 23 without Coupling
SP29 Motor Block NEMA 34 without Coupling
SP30 Motor Block Neo 70 with 11.0 mm Bore Coupling

⑨ **Gearbox Option***
G0 No Gearbox (Requires MBR, MBL, MRW, MLW)
G1 Customer Supplied Gearhead*
G1203 PV60 Gearhead 3:1 Ratio
G1205 PV60 Gearhead 5:1 Ratio
G1210 PV60 Gearhead 10:1 Ratio
G1215 PV60 Gearhead 15:1 Ratio
G1225 PV60 Gearhead 25:1 Ratio
*Contact factory for approval of any alternative gearbox information.

⑩ **Mounting Orientation**
H1 Carriage Up
H2 Carriage Down
H3 Carriage on Side, Drive Station Up
H4 Carriage on Side, Drive Station Down

⑪ **Motor Kit Option**
K00 No Motor Kit
K21 Motor Kit LV23, HV23, OS23, ES23, VS23 to PV60
K22 Motor Kit BE23X to PV60
K23 Motor Kit SM23, SE23 to PV60
K24 Motor Kit LV34, HV34
K25 Motor Kit BE34, NO34X, JO34X, TS31, TS32 to PV60
K26 Motor Kit RS34, ES34 to PV60
K27 Motor Kit NO70, JO70 to PV60
K28 Motor Kit SMB60 to PV60

⑫ **Strip Seal Option**
ZA Unit with Strip Seal (IP30)
ZB Unit without Strip Seal

⑬ **Limit/Home Switch Option**
LH0 No Limit Switch Assembly
LH1 Three Mechanical Switches (1 NO & 1 NC Contact Per Switch)
LH2 Two Mechanical Switches (1 NO & 1 NC Contact Per Switch)
LH3 Three NPN Prox Switches, 10-30 VDC
LH4 Three PNP Prox Switches, 10-30 VDC

Belt Driven
Tables

Fill in an order code from each of the numbered fields to create a complete model order code.

	①	②	③	④	⑤	⑥	⑦	⑧	⑨	⑩	⑪	⑫	⑬
Order Example:	HLE100	RB	NL	E	1000	DA0000	ARO	SP7	G2-05	H2	ZB	K6	LH0

- ① **Series**
HLE100
- ② **Bearing Type**
RB
- ③ **Carriage Type**
NL Standard Carriage
VL Extended Carriage
- ④ **Unit Type**
M Idler
D Dual Axis Unit
E Timing Belt Drive, Nominal Thrust, Maximum Life
- ⑤ **Travel Length**
nnnn Specified travel in mm (nnnn = mm)
- ⑥ **Drive Shaft Option - Center to Center**
DA0000 No Drive Shaft - Single Axis or Idler Unit
DAnnnn (nnnn=mm)
- ⑦ **Shaft Configuration Options**
WOO No Shaft, Idler Unit
WLO Shaft Left
WRO Shaft Right
WBO Double Shaft
ALO Reducer Left
ARO Reducer Right
ALW Reducer Left, Shaft Right
ARW Reducer Right, Shaft Left
DAL Double Axis, Drive Left
DAR Double Axis, Drive Right
MBL Motor Block Left
MBR Motor Block Right

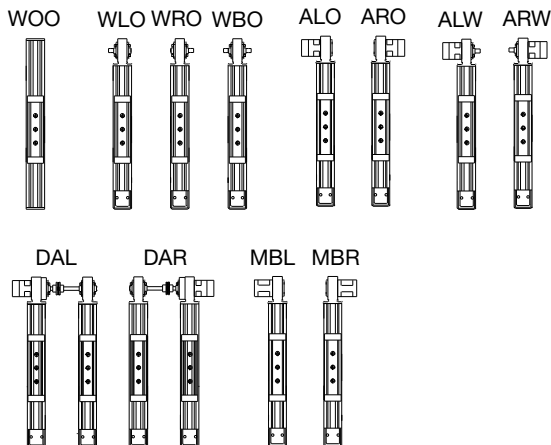

- ⑧ **Drive Station Interface**
SP0 Idler or Shaft Option
SP1 Drive Housing for GTN /GTR-090
SP2 Drive Housing for GTN / GTR / PEN / PER-115
SP3 Motor Block - NEMA 34 with 0.500 in. coupling
SP4 Motor Block - NEMA 34 with 0.375 in. coupling
SP5 Motor Block - NEMA 34 without coupling
SP6 Motor Block - with coupling for JO923 direct drive
SP7 Motor Block - NEMA 42 with 0.625 in. coupling
SP8 Motor Block - NEMA 42 without coupling
SP9 Drive Housing for PEN / PER-090
- ⑨ **Gearbox Option**
G0-00 No Gearbox
G2-nn PEN-090**
G3-nn PER-090**
G4-nn PEN-115**
G5-nn PER-115**
G6-nn GTN-090*
G7-nn GTR-090*
G8-nn GTN-115*
G9-nn GTR-115*
*Single stage ratios: 3, 5, 8, 10; Dual stage ratios: 12, 15, 16, 20, 25
**Single stage ratios: 3, 4, 5, 8; Dual stage ratios: 9, 12, 15, 16, 20, 25
- ⑩ **Mounting Orientation**
H1 Carriage Up
H2 Carriage Down
H3 Carriage on Side, Drive Station Up
H4 Carriage on Side, Drive Station Down
- ⑪ **Strip Seal Option**
ZA Unit with Strip Seal (IP30)
ZB Unit without Strip Seal
- ⑫ **Motor Kit Option**
K0 No motor kit
K1 J034*, N034*, BE34*, TS31, TS32 to GT-090, PE-090
K2 J070*, N070* to GT-090, PE-090
K3 J090*, N090* to GT-090, PE-090
K4 M105* to GT-090, PE-090
K5 ES3*, OEM83-*, ZETA83-*, S83-*, RS3* to GT-090, PE-090
K6 J034*, N034*, BE34*, TS3
K7 J090*, N090*
K8 M105*
K9 ES3*, OEM83-*, ZETA83-*, S83-*, RS3*
K10 RS42, RE42, S106-205
K11 S106-178, S106-250
K12 M145
K35 MPP092
K37 MPP100
K39 MPP115
*Single stage ratios: 3, 5, 8, 10; Dual stage ratios: 12, 15, 16, 20, 25
- ⑬ **Limit/Home Switch Option**
LH0 No Limit Switch Assembly
LH1 Three Mechanical Switches, 1 NO and 1 NC contact per switch
LH2 Two Mechanical Switches, 1 NPN Prox Switch
LH3 Three NPN Prox Switches, 10-30 VDC
LH4 Three PNP Prox Switches, 10-30 VDC



Fill in an order code from each of the numbered fields to create a complete model order code.

	①	②	③	④	⑤	⑥	⑦	⑧	⑨	⑩	⑪	⑫	⑬
Order Example:	HLE150	RB	NL	E	1000	DA0000	ARO	SP1	G2-05	H2	ZA	K7	LH2

- ① **Series**
HLE150
- ② **Bearing Type**
RB
- ③ **Carriage Type**
NL Standard Carriage
VL Extended Carriage
- ④ **Unit Type**
M Idler
E Timing Belt Drive, Nominal Thrust, Maximum Life
F Timing Belt Drive, Maximum Thrust, Nominal Life
- ⑤ **Travel Length**
nnnn Specified travel in mm (nnnn = mm)
- ⑥ **Drive Shaft Option - Center to Center**
DA0000 No Drive Shaft - Single Axis or Idler Unit
DAnnnn (nnnn=mm)
- ⑦ **Shaft Configuration Options**
WOO No Shaft, Idler Unit
WLO Shaft Left
WRO Shaft Right
WBO Double Shaft
ALO Reducer Left
ARO Reducer Right
ALW Reducer Left, Shaft Right
ARW Reducer Right, Shaft Left
DAL Double Axis, Drive Left
DAR Double Axis, Drive Right

- ⑧ **Drive Station Interface**
SP0 Idler or Shaft Option
SP1 Drive Housing for GTN115
SP2 Drive Housing for GTN142
SP9 Drive Housing for PEN115
- ⑨ **Gearbox Option**
G0-00 No Gearbox
G2-*nn* PEN-115**
G3-*nn* PER-115**
G4-*nn* GTN-115*
G5-*nn* GTR-115*
G6-*nn* GTN-142*
G7-*nn* GTR-142*
*Single stage ratios: 3, 5, 8, 10; Dual stage ratios: 12, 15, 16, 20, 25
**Single stage ratios: 3, 4, 5, 8; Dual stage ratios: 9, 12, 15, 16, 20, 25
- ⑩ **Mounting Orientation**
H1 Carriage Up
H2 Carriage Down
H3 Carriage on Side, Drive Station Up
H4 Carriage on Side, Drive Station Down
- ⑪ **Strip Seal Option**
ZA Unit with Strip Seal (IP30)
ZB Unit without Strip Seal
- ⑫ **Motor Kit Option**
K0 No motor kit
K6 J034*, N034*, BE34*, TS31, TS32 to GT-115, PE-115
K7 J090*, N090* to GT-115, PE-115
K8 M105* to GT-115, PE-115
K9 ES3*, OEM83-*, ZETA83-*, S83-*, RS3* to GT-115, PE-115
K10 RS42, RE42, S106-205 to GT-115, PE-115
K11 S106-178, S106-250 to GT-115, PE-115
K12 M145 to GT-115, PE-115
K13 M145 to GT-142, PE-142
*Single stage ratios: 3, 5, 8, 10; Dual stage ratios: 12, 15, 16, 20, 25
- ⑬ **Limit/Home Switch Option**
LH0 No Limit Switch Assembly
LH1 Three Mechanical Switches, 1 NO and 1 NC contact per switch
LH2 Two Mechanical Switches, 1 NPN Prox Switch
LH3 Three NPN Prox Switches, 10-30 VDC
LH4 Three PNP Prox Switches, 10-30 VDC

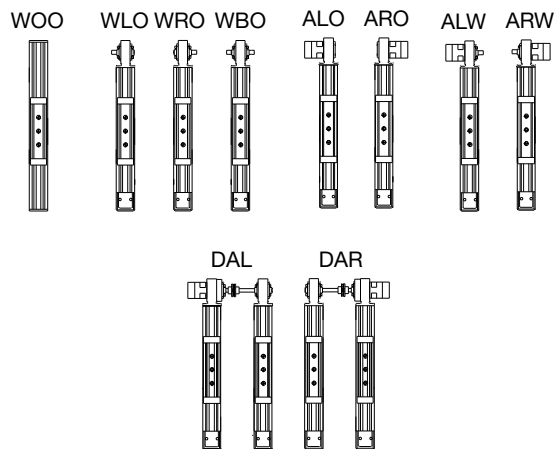

Belt Driven Tables



HLE-SR Series Belt Driven Linear Modules

Features

- Heavy duty steel square rail bearing system for greater load capacity
- Standard travel to 6 meters*
- Load capacities up to 600 kg
- Velocity up to 3 meters/sec.
- ± 0.2 mm positional repeatability
- Timing belt and pulley drive mechanism
- IP30 strip seal

*Longer travels available with splice kits.



HLE-SR Bearing System

The bearing system is the principal distinction between the RB (Roller Bearing) type modules and the SR (Square Rail) type. The SR employs a square rail bearing system, which permits greater load carrying capability without increasing overall size. Square rail bearings are recirculating ball bearings designed to move heavy loads on a precise linear path. Linear guides, which house several rows of re-circulating ball bearings, ride on a high strength, steel square rail. The steel square rail cross section enables bearing ways to be ground into the sides of the rail. These bearing ways are shaped in an arch which approximates the same radius as the ball bearing. This increases the contact surface between the ball and the rail, thereby increasing the load capacity of the linear bearing.

HLE-SR Drive Principle

The HLE-SR employs the same high performance belt and pulley drive mechanism as the HLE-RB. It features a zero backlash steel reinforced timing belt drive, which provides high speeds, high acceleration, and good bidirectional repeatability. A belt tension station, conveniently located at the end of the unit provides for quick and easy belt adjustment. The drive station is designed to accept planetary gear reducers as well as a wide variety of servo and stepper motors.

Proven Technology

Proven in numerous applications, the HLE-SR series offers the following advantages:

- Low running friction
- Low wear
- Low maintenance
- Quiet operation
- High efficiency
- Long service life
- High dynamic performance due to high load capacity square rail systems
- Easily accessible lubrication points
- Minimal preventive maintenance required
- T-slots integrated on sides of the profile for mounting attachments or for use as a cable duct
- Timing belts can be replaced without removing load attachment plate
- Multiple configuration options due to T-slots available on both the profile and load plate



Typical Fields of Application

As part of advanced, cost-effective construction of machines and handling systems:

- Materials handling: palletizing, depalletizing, feeding, part removal
- Clean room technology: water transport, water coating
- Warehouse technology: parts picking, storage and retrieval
- Machine tool automation: workpiece loading and unloading, tool changing
- Construction: formwork, placing reinforcing steel bars in concrete
- Process engineering: painting, coating, bonding
- Testing technology: guiding ultrasonic sensors, laboratory equipment
- Textile machinery building: cross-cutting, slitting and stacking, quilting, seam stitching

Optional Features

- Direct mounting for planetary gear reducers
- Adjustable “end of travel” limit switches and “Home” position sensor
- Cable carrier systems
- Performance matched Parker servo systems
- Structural components for vertical and multi-axis mounting
- Toe clamps and hardware for fast/easy mounting
- External bumpers
- Link shafts and support bearing for dual unit axes
- Splice plates for extending travels beyond length available in a single profile

See pages 272-276 for available options and accessories.

Housing

The HLE-SR housing is a light-weight, compact and self-supporting extruded aluminum section. It is available in two cross-sections: 60 x 60 mm (HLE60) and 100 x 100 mm (HLE100). T-slots along the length are utilized for clamping mechanical components, joining units, and attaching sensors or mechanical switches.

Carriage

A rigid carriage assembly is built upon two bearing housings which contain several rows of recirculating ball bearings designed to ride in grooves ground into a steel square rail linear raceway. Longer or custom carriages are also available.

Load Attachment Plate

Longitudinal T-Slots integrated on the top of this plate facilitate the assembly of attachments to the HLE-SR. Utilization of these T-Slots together with standard clamping profiles enables easy straight-forward construction of multi-axis systems.

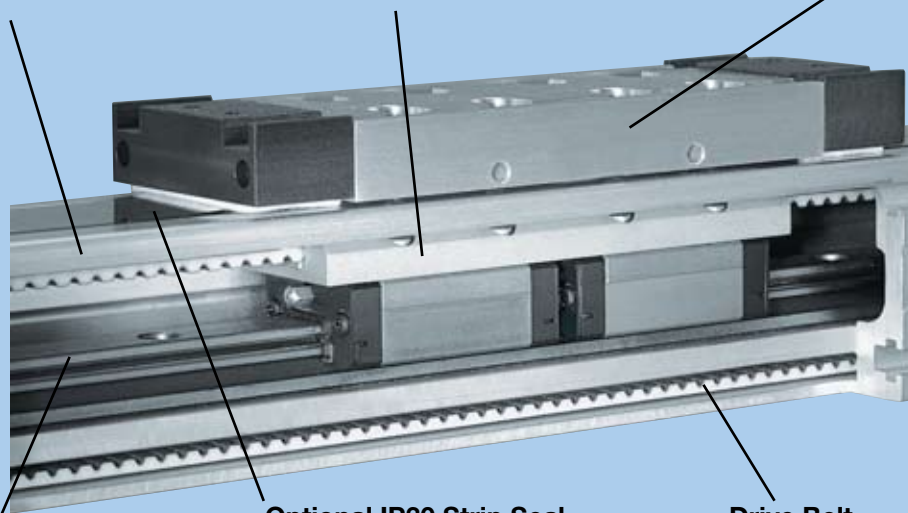

Bearing Raceway

A high strength steel alloy bearing rail features precision ground “gothic arch” raceways to provide precise translation and high strength support of the recirculating ball bearings.

Optional IP30 Strip Seal

Magnetically attached stainless steel seal strip provides environmental protection to interior components.

Drive Belt

A zero backlash, steel reinforced timing belt provides high speed, high acceleration and high bidirectional repeatability. A serrated clamp mechanism between belt and carriage guarantees a safe and strong connection.

Belt Driven Tables

HLE-SR Series Specifications

Characteristic	Units	HLE60-SR		HLE100-SR	
Unit Weight (basic unit without stroke)					
Standard Carriage, NL	kg (lb.)	3.5	(7.7)	16.2	(35.7)
Extended Carriage, VL	kg (lb.)	5.91	(13)	20.0	(44.1)
Carriage Weight					
Standard Carriage, NL	kg. (lb)	1.8	(4.0)	2.2	(4.9)
Extended Carriage, VL	kg. (lb)	2.1	(4.6)	3.8	(8.4)
Weight per meter of additional length	kg/m (lb/ft)	5.5	(3.7)	13.3	(8.9)
Moment of Inertia (related to the drive shaft)					
Standard Carriage, NL	kg-cm ² (lb-in ²)	3.52	(1.20)	34.8	(11.9)
Extended Carriage, VL	kg-cm ² (lb-in ²)	5.20	(1.83)	52.2	(17.9)
Travel and Speed					
Maximum Speed ⁽¹⁾	m/s (in/s)	3	(120)	3	(120)
Maximum Acceleration ⁽¹⁾	m/s ² (in/s ²)	10	(393)	10	(393)
Maximum Travel ⁽²⁾ , NL	m (in)	3.05	(120)	6.15	(242)
Maximum Travel ⁽²⁾ , VL	m (in)	2.8	(114)	6.0	(236)
Geometric Data					
Cross Section, Square	mm (in)	57.2	(2.25)	100	(3.94)
Moment of Inertia I _x	cm ⁴ (in ⁴)	48.3	(1.16)	377	(9.06)
Moment of Inertia I _y	cm ⁴ (in ⁴)	59.5	(1.43)	432	(10.38)
Moment of Elasticity	N/mm ² (lb/in ²)	0.72 x 10 ⁵	(0.1044 x 10 ⁸)	0.72 x 10 ⁵	(0.1044 x 10 ⁸)
Pulley Data, Torques, Forces					
Travel Distance per Revolution	mm/rev (in/rev)	125	(4.92)	240.0	(9.45)
Pulley Diameter	mm (in)	39.8	(1.57)	74.5	(2.93)
Maximum Drive Torque ⁽³⁾	Nm (lb-in)	8.87	(79)	61.5	(544)
Maximum Belt Traction ⁽³⁾ (effective load)	N (lb)	668	(150)	1650	(371)
Repeatability ⁽⁴⁾	mm (in)	±0.2	(±0.008)	±0.2	(±0.008)

For the following deviations from the above standards, please contact Parker engineering: (1) Greater speeds and accelerations may be achieved. (2) Splicing possible for longer travel distances. This may cause reductions in effective load, drive torque, speed, acceleration, and repeatability. (3) Increased timing belt tension required. (4) Nominal value - component dependant. For improved repeatability consult factory.

Linear Actuator Size Comparison

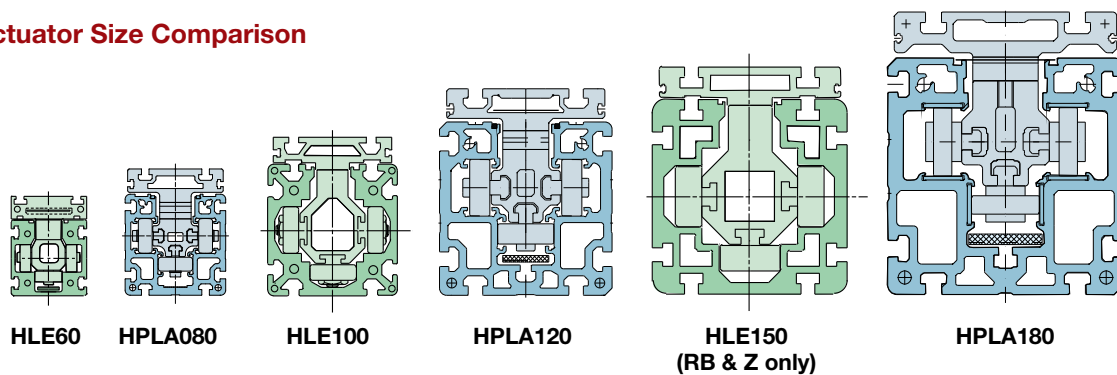



Load-Bearing Capacity of Carriage and Timing Belt

Forces and Moment Loads

The forces and moments that the carriage is capable of transferring are speed-dependent. The curves shown in the graphs apply to a standard carriage (S). With the extended carriage (E), all the values apart from F_x (load-bearing capacity of timing belt) can be doubled if the load is applied equally to both halves of the carriage or distributed uniformly along its entire length.

The curves show the maximum load-bearing capacity of a carriage in one direction of force or torque. If several loads are applied in different directions, the values given by the curves must be derated, i.e. the load or speed should be reduced if necessary.

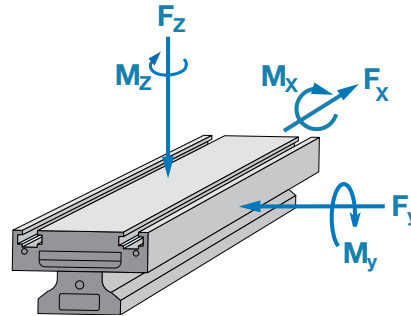

“DimAxes” software is available for determination of precise carriage loading.

Visit www.parkermotion.com to request a Gantry Robot CD.

Load-Bearing Capacity Timing Belt (F_x)

HLE60-SR

Drive Option	Transferrable Thrust Force (n)	
	Nominal Belt Tension (81,000 km life)	Maximum Belt Tension (46,000 km life)
Supported Pulley (SP19 - SP30)	500	–

HLE100-SR

Drive Option	Transferrable Thrust Force (n)	
	Nominal Belt Tension (81,000 km life)	Maximum Belt Tension (46,000 km life)
GTN115	925	1115
GTN090, PEN115	675	900
PEN090	500	665

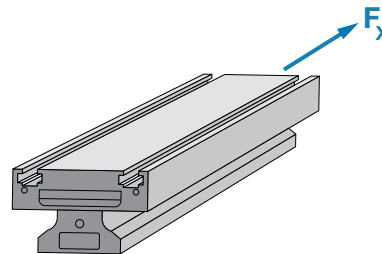

Belt Driven Tables

HLE-SR Performance Curves

The force and moment capabilities of the carriage and the timing belt are speed dependent. The load curves shown in the graphs are valid for a standard (NL order code) carriage. These curves show the allowable force or moment versus the nominal carriage life.

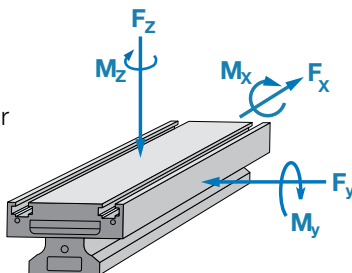

Legend

Curve	Velocity	
	m/sec.	(in/sec.)
A	0.25	(10)
B	0.50	(20)
C	1.00	(40)
D	2.00	(80)
E	3.00	(120)

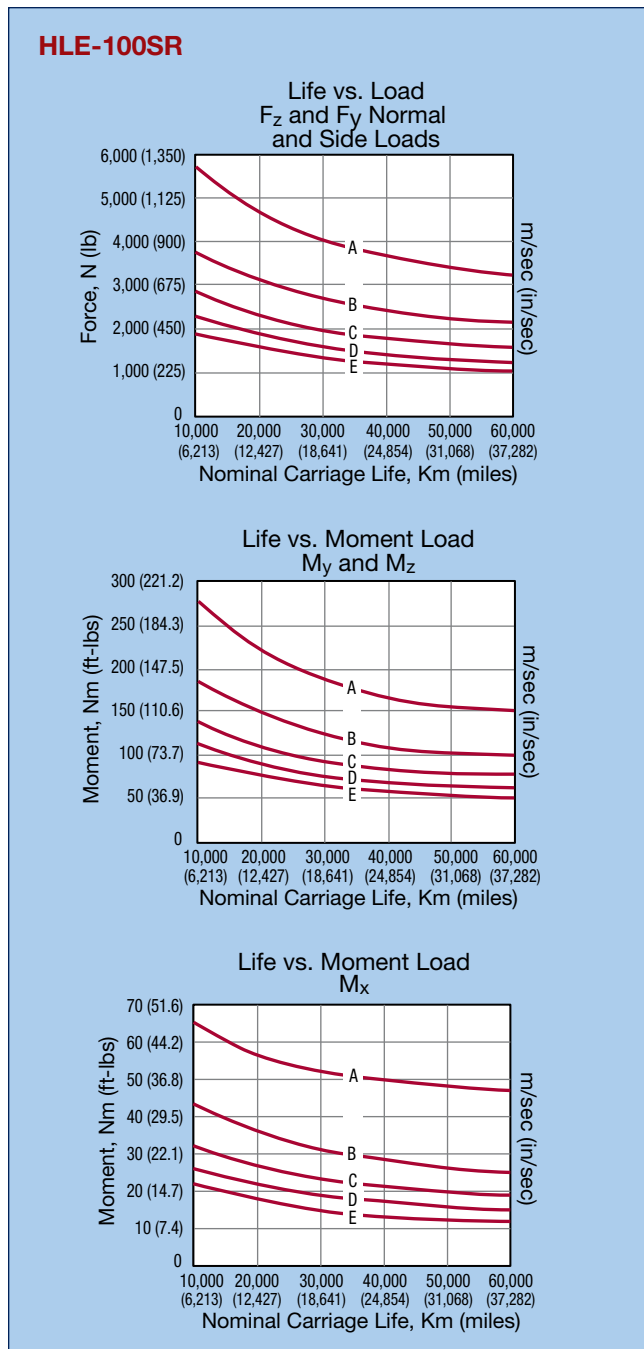
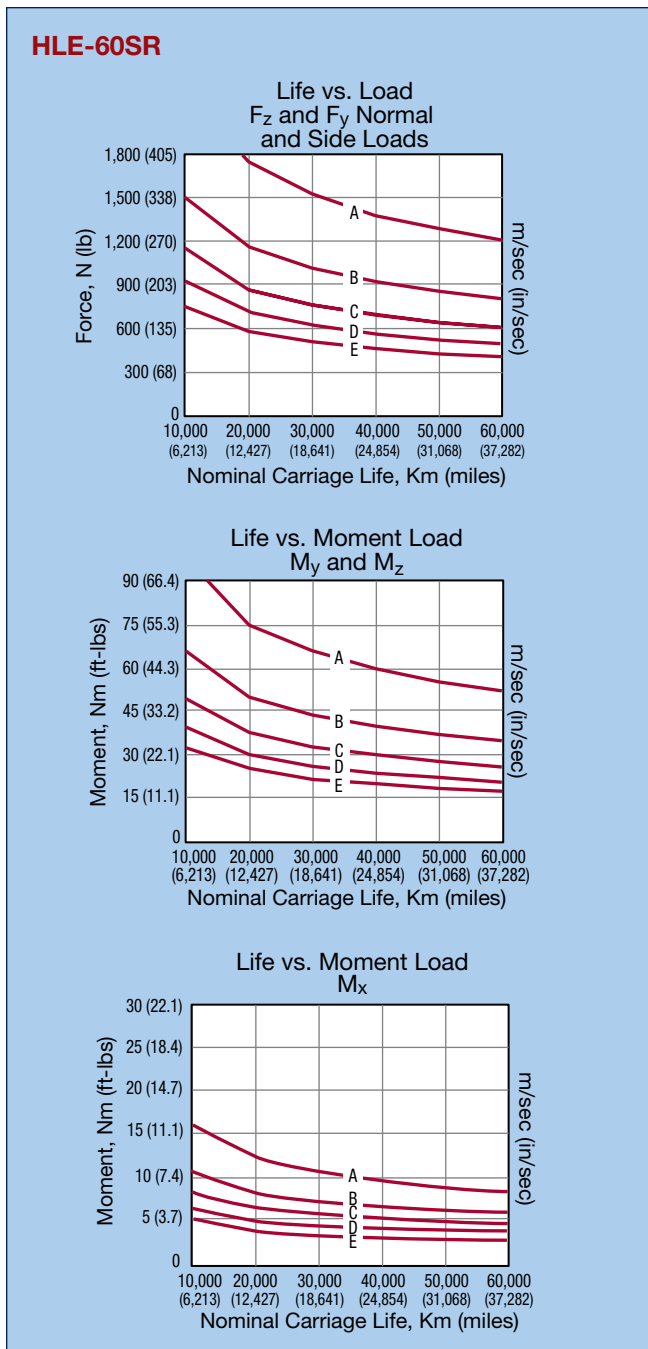



HLE-SR Deflection Characteristics

The HLE deflection curves can be used for determining the deflection based on the profile length and the application load weight. Applications requiring high acceleration forces can place a severe strain on the system stability. In these cases, a solid substructure may be required with the HLE product being supported at frequent intervals.

These deflection curves illustrate the deflection δ , based on the HLE profile being simply supported at both ends. The graphs take into consideration the self deflection due to the weight of the profile, along with the load to be transported. The maximum deflection cannot be exceeded unless additional supports are implemented. Alternatively, the next larger profile size may be considered. For deflection formulas and calculations, please refer to the Technical Information Library found on our web site www.parkermotion.com

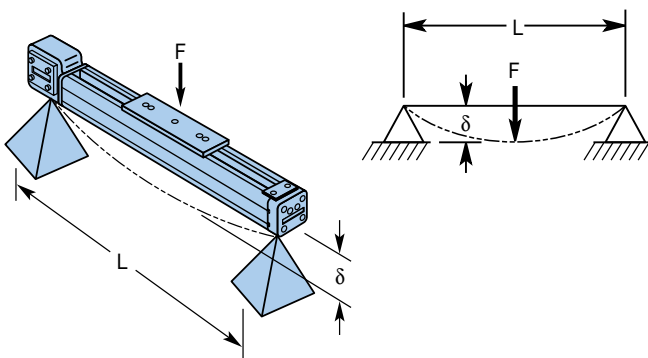

F = Force N
 L = Unsupported length mm
 δ = Deflection mm

Deflection Curves

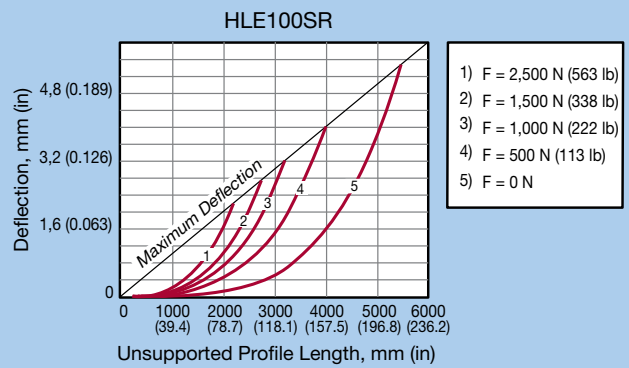
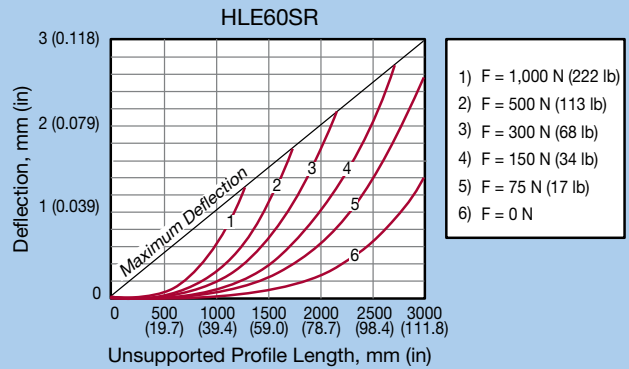

Belt Driven Tables

HLE60-SR with PV60 Direct Drive

Dimensions (mm)

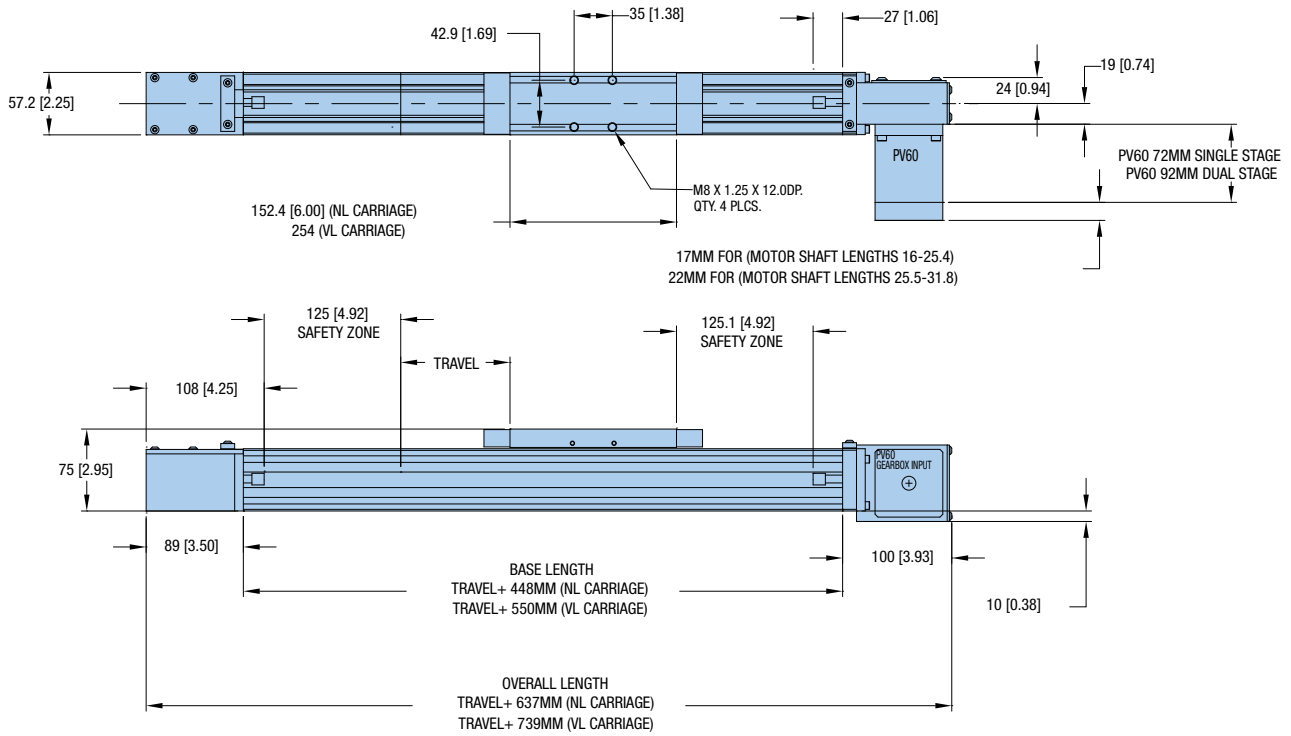



HLE60-SR Drive with Motor Block

Dimensions (mm)

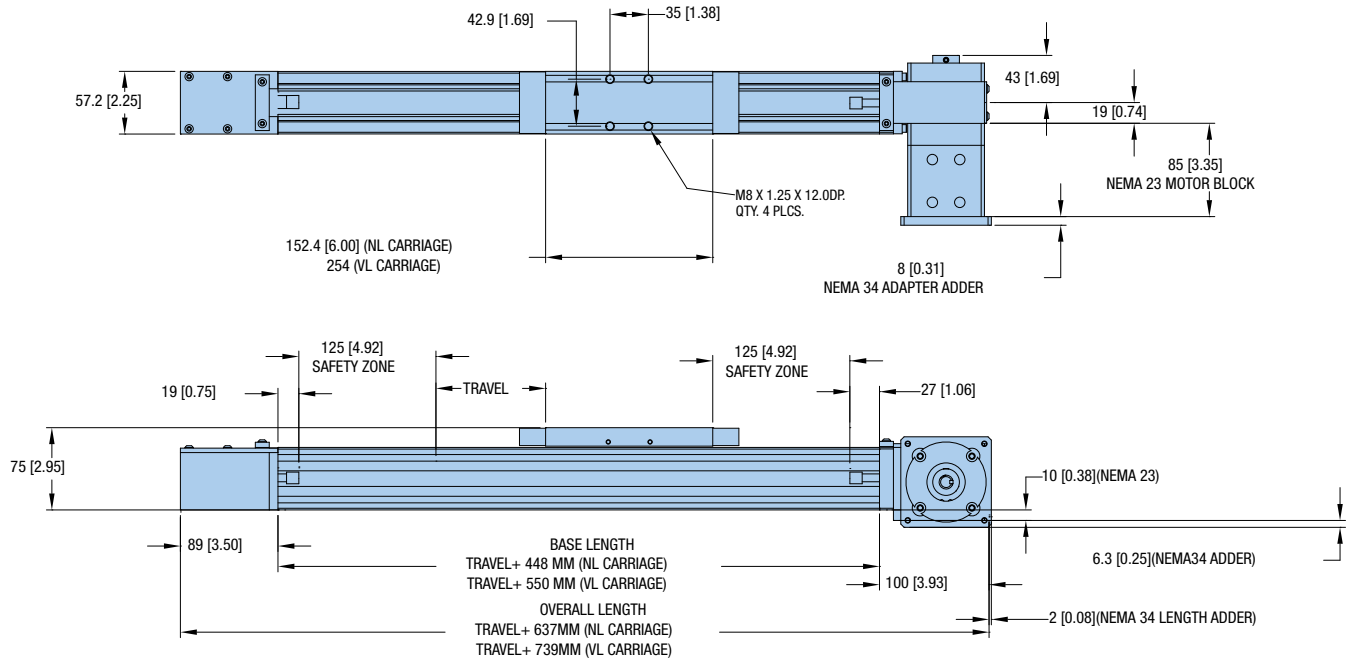

Belt Driven
Tables

HLE60-SR Idler

Dimensions (mm)

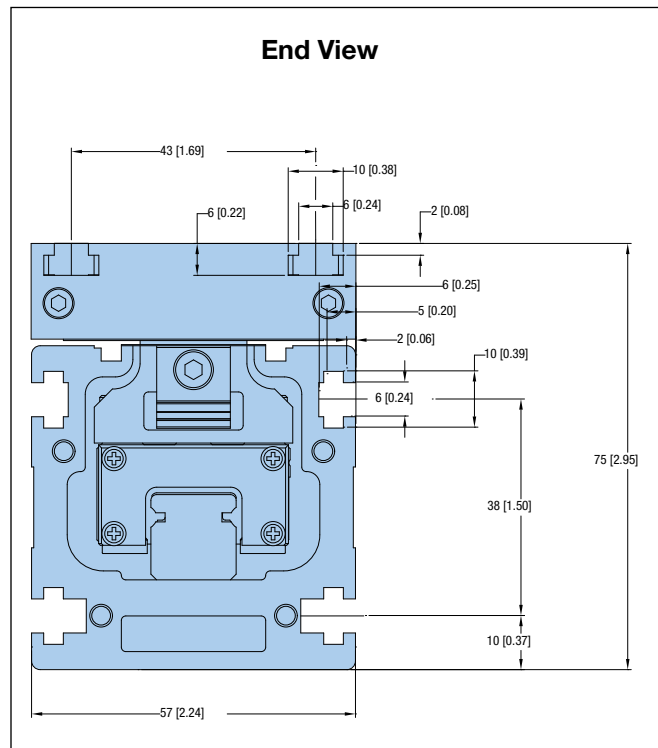
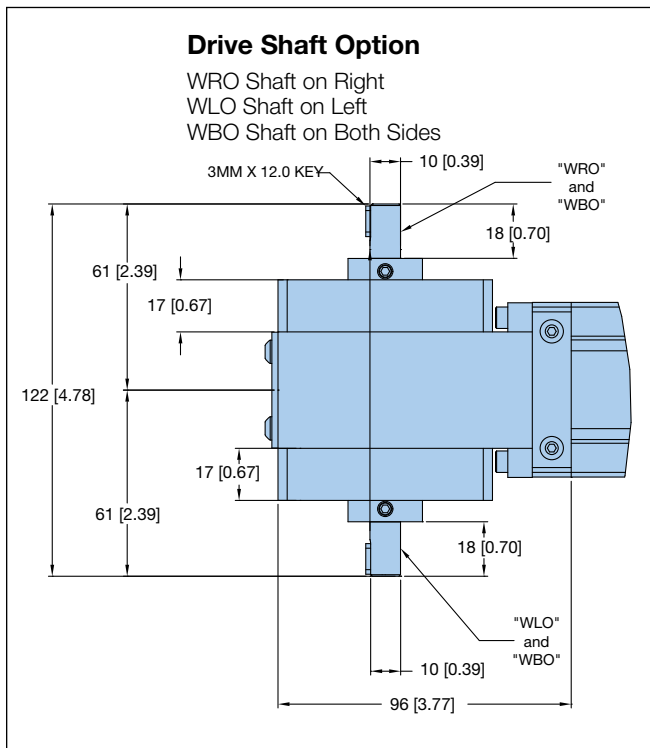
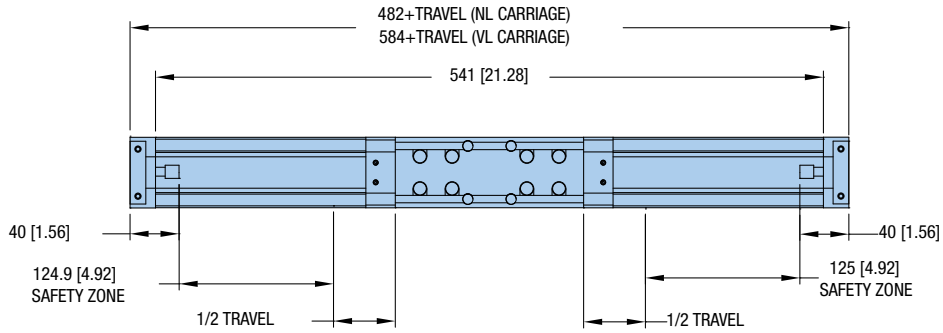



HLE100-SR Drive

Dimensions (mm)

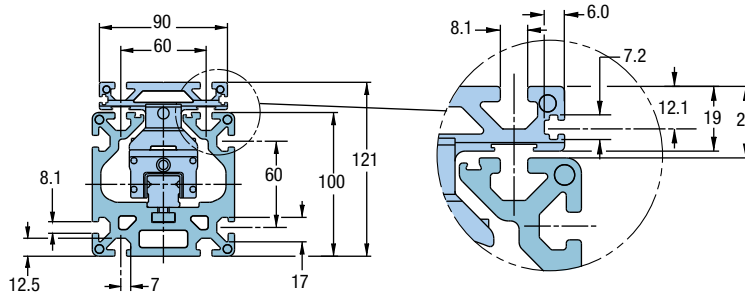
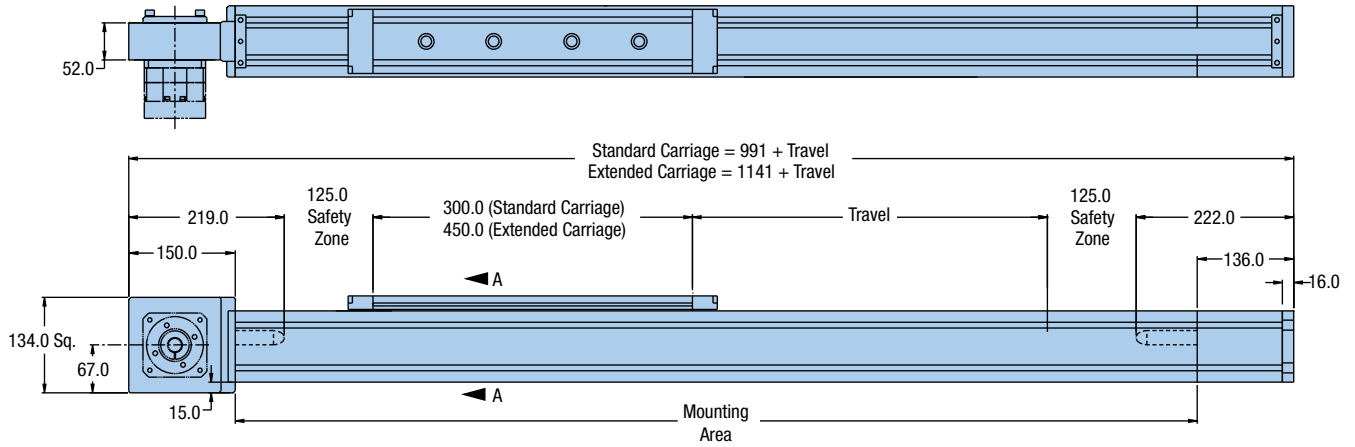

Section A-A

Drive Shaft Option

WRO Shaft on Right
WLO Shaft on Left
WBO Shaft on Both Sides

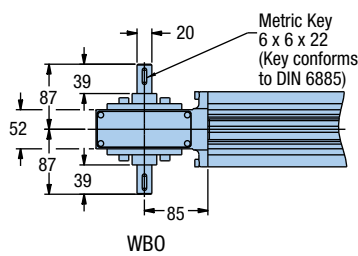

WBO

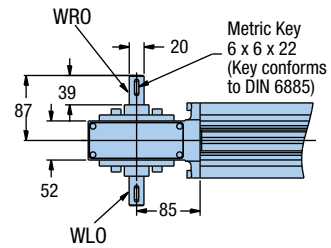

WLO

HLE100-SR Idler

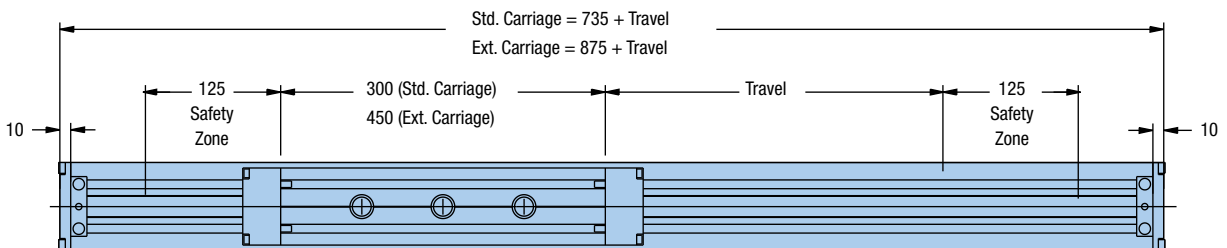

Fill in an order code from each of the numbered fields to create a complete model order code.

	①	②	③	④	⑤	⑥	⑦	⑧	⑨	⑩	⑪	⑫	⑬
Order Example:	HLE060	SR	NL	E	2000	DA000	MBR	SP5	G1205	H1	K24	ZA	LH0

- ① **Series**
HLE060
- ② **Bearing Type**
SR
- ③ **Carriage Type**
NL Standard Carriage
VL Extended Carriage
- ④ **Unit Type**
M Idler
D Dual Axis Unit
E Single Axis Unit
- ⑤ **Travel Length**
nnnn nnnn=mm (3000 mm max for NL carriage;
2900 mm max for VL carriage)
- ⑥ **Drive Shaft Option - Center to Center**
DA0000 No Drive Shaft - Single Axis or Idler Unit
DAnnnn (nnnn=mm) Dual Axis Center to Center
(200 mm min; 1500 mm max)
DCnnnn (nnnn=mm) Dual Axis with Covered Link Shaft Center
to Center (200 mm min; 1500 mm max)
- ⑦ **Shaft Configuration Options**
WOO No Shaft, Idler Unit
ARO Gearhead Right
ALO Gearhead Left
ARW Gearhead Right Shaft Left
ALW Gearhead Left Shaft Right
WLO Shaft Left
WRO Shaft Right
WBO Double Shaft
MBL Motor Block Left
MBR Motor Block Right
MLW Motor Block Left, Shaft Right
MRW Motor Block Right, Shaft Left
DAL Double Axis Gearhead, Drive Left
DAR Double Axis Gearhead, Drive Right
DML Double Axis, Motor Block Left
DMR Double Axis, Motor Block Right

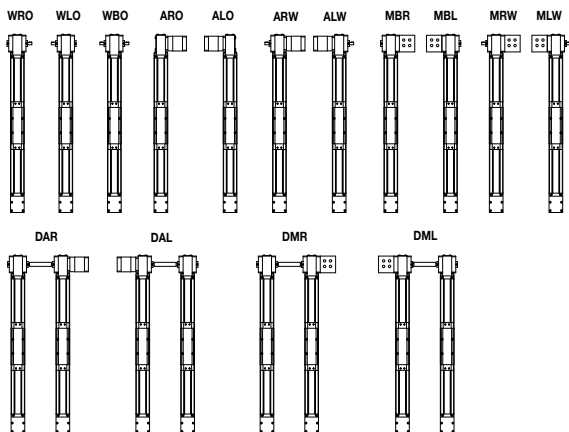

- ⑧ **Drive Station Interface**
SP19 Drive Housing For PV60-FN
SP20 Idler Unit
SP21 No Motor Block
SP22 Motor Block NEMA 23 with 0.375" Bore Coupling
SP23 Motor Block NEMA 34 with 0.25" Bore Coupling
SP24 Motor Block NEMA 34 with 0.375" Bore Coupling
SP25 Motor Block NEMA 34 with 0.50" Bore Coupling
SP28 Motor Block NEMA 23 without Coupling
SP29 Motor Block NEMA 34 without Coupling
SP30 Motor Block Neo 70 with 11.0 mm Bore Coupling
- ⑨ **Gearbox Option***
G0 No Gearbox (Requires MBR, MBL, MRW, MLW)
G1 Customer Supplied Gearhead*
G1203 PV60 Gearhead 3:1 Ratio
G1205 PV60 Gearhead 5:1 Ratio
G1210 PV60 Gearhead 10:1 Ratio
G1215 PV60 Gearhead 15:1 Ratio
G1225 PV60 Gearhead 25:1 Ratio
*Contact factory for approval of any alternative gearbox information.
- ⑩ **Mounting Orientation**
H1 Carriage Up
H2 Carriage Down
H3 Carriage on Side, Drive Station Up
H4 Carriage on Side, Drive Station Down
- ⑪ **Motor Kit Option**
K00 No Motor Kit
K21 Motor Kit LV23, HV23, OS23, ES23, VS23 to PV60
K22 Motor Kit BE23X to PV60
K23 Motor Kit SM23, SE23 to PV60
K24 Motor Kit LV34, HV34 to PV60
K25 Motor Kit BE34, NO34X, JO34X, TS31, TS32 to PV60
K26 Motor Kit RS34, ES34 to PV60
K27 Motor Kit NO70, JO70 to PV60
K28 Motor Kit SMB60 to PV60

- ⑫ **Strip Seal Option**
ZA Unit with Strip Seal (IP30)
ZB Unit without Strip Seal
- ⑬ **Limit/Home Switch Option**
LH0 No Limit Switch Assembly
LH1 Three Mechanical Switches (1 NO & 1 NC Contact Per Switch)
LH2 Two Mechanical Switches (1 NO & 1 NC Contact Per Switch)
LH3 Three NPN Prox Switches, 10-30 VDC
LH4 Three PNP Prox Switches, 10-30 VDC



Fill in an order code from each of the numbered fields to create a complete model order code.

① ② ③ ④ ⑤ ⑥ ⑦ ⑧ ⑨ ⑩ ⑪ ⑫ ⑬

Order Example:

HLE100 SR NL E 2000 DA000 ARO SP2 G2-03 H1 ZB K2 LH0

① **Series**
HLE100

② **Bearing Type**
SR

③ **Carriage Type**
NL Standard Carriage
VL Extended Carriage

④ **Unit Type**
M Idler
E Timing Belt Drive, Nominal Thrust, Maximum Life
F Timing Belt Drive, Nominal Thrust, Maximum Thrust

⑤ **Travel Length**
nnnn Specified travel in mm (nnnn = mm)

⑥ **Drive Shaft Option - Center to Center**
DA0000 No Drive Shaft - Single Axis or Idler Unit
DAnnnn (nnnn=mm)

⑦ **Shaft Configuration Options**

- WOO No Shaft, Idler Unit
- WLO Shaft Left
- WRO Shaft Right
- WBO Double Shaft
- ALO Reducer Left
- ARO Reducer Right
- ALW Reducer Left, Shaft Right
- ARW Reducer Right, Shaft Left
- DAL Double Axis, Drive Left
- DAR Double Axis, Drive Right
- MBL Motor Block Left
- MBR Motor Block Right

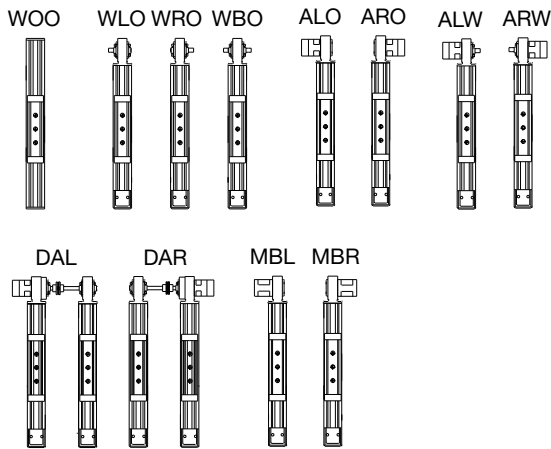

⑧ **Drive Station Interface**

- SP0 Idler or Shaft Option
- SP1 Drive Housing for GTN /GTR-090
- SP2 Drive Housing for GTN / GTR / PEN / PER-115
- SP3 Motor Block - NEMA 34 with 0.500 in. coupling
- SP4 Motor Block - NEMA 34 with 0.375 in. coupling
- SP5 Motor Block - NEMA 34 without coupling
- SP6 Motor Block - with coupling for JO923 direct drive
- SP7 Motor Block - NEMA 42 with 0.625 in. coupling
- SP8 Motor Block - NEMA 42 without coupling
- SP9 Drive Housing for PEN / PER-090

⑨ **Gearbox Option**

- G0-00 No Gearbox
- G2-nn PEN-090**
- G3-nn PER-090**
- G4-nn PEN-115**
- G5-nn PER-115**
- G6-nn GTN-090*
- G7-nn GTR-090*
- G8-nn GTN-115*
- G9-nn GTR-115*

*Single stage ratios: 3, 4, 5, 8, 10; Dual stage ratios: 12, 15, 16, 20, 25
**Single stage ratios: 3, 4, 5, 8; Dual stage ratios: 9, 12, 15, 16, 20, 25

⑩ **Mounting Orientation**

- H1 Carriage Up
- H2 Carriage Down
- H3 Carriage on Side, Drive Station Up
- H4 Carriage on Side, Drive Station Down

⑪ **Strip Seal Option**

- ZA Unit with Strip Seal (IP30)
- ZB Unit without Strip Seal

⑫ **Motor Kit Option**

- K0 No Motor Kit
- K1 J034*, N034*, BE34*, TS3* to GTN, PEN-090
- K2 J070*, N070* to GTN, PEN-090
- K3 J090*, N090* to GTN, PEN-090
- K4 M105* to GTN, PEN-090
- K5 ES3*, OEM83-*, ZETA83-*, S83-*, RS3* to GTN, PEN-0-90
- K6 J034*, N034*, BE34*, TS3* to GTN, PEN-115
- K7 J090*, N090* to PE-115 or GTN, PEN-115
- K8 M105* to PE-115 or GTN, PEN-115
- K9 ES3*, OEM83-*, ZETA83-*, S83-*, RS3* to GTN, PEN-115
- K10 RS42, RE42, S106-205 to GTN, PEN-115
- K11 S106-178, S106-250 to GTN, PEN-115
- K12 M145 to GTN, PEN-115ZETA57-83-MO-S
- K35 MPP092
- K37 MPP100
- K39 MPP115

*Single stage ratios: 3, 4, 5, 8, 10; Dual stage ratios: 12, 15, 16, 20, 25

⑬ **Limit/Home Switch Option**

- LH0 No Limit Switch Assembly
- LH3 Three NPN Prox Switches, 10-30 VDC
- LH4 Three PNP Prox Switches, 10-30 VDC

Belt Driven Tables



HLE-Z Series

Features

- Long travels – selectable up to 50 meters
- Load capacities up to 600 kg
- Up to 5 meters/sec. velocity
- ± 0.05 mm positional repeatability
- Rack-and-pinion drive mechanism
- Independent multiple carriages on single rail
- Roller wheel bearings for smooth high speed linear motion

The “endless” linear unit is designed for guiding, transporting or positioning payloads over long travel distances with high rigidity and accuracy. This is accomplished by incorporating Parker’s uniquely designed rack-and-pinion based drive system with an HLE150 linear module housing. The exceptional dynamic characteristics inherent to these units make them well suited for applications requiring high speed linear translation and positioning over long travel distances.

The carriage drive mechanism is independent of the housing mechanics. As a result, multiple carriage applications, where several carriages can be positioned on a single unit independently of each other, are easily accommodated. Mechanical compatibility with the HLE series and other Parker components permit efficient, cost-effective construction of gantry robots and automated systems.



HLE-Z Drive Principle

The HLEZ drive offers all the advantages of a rack drive, but without the usual drawbacks. The short timing belt (which is independent of travel length) reduces belt stretching to an absolute minimum. The lateral deflection roller pretensions the system and thereby removes backlash. “Hold down” rollers ensure that sufficient teeth always remain in mesh. The combination of a steel reinforced polyurethane timing belt and an aluminum rack-and-pinion is a safe and clean drive which requires no lubrication.

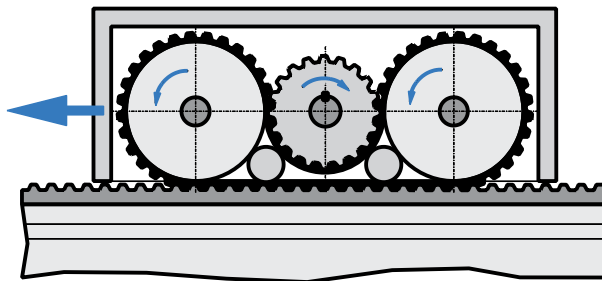

See pages 272-276 for available options and accessories.



Combined Technology

Linear actuator and rack offers the following advantages:

- High dynamic response, even over long travel distances, due to:
 - the short timing belt, regardless of travel length
 - the lightweight carriage
 - the backlash-free drive
- High positional repeatability, regardless of stroke length
- Option of several carriages per linear unit, making overlapping strokes along a single axis possible
- Longer maintenance free life

Typical Applications

As part of advanced, cost-effective construction of machines and handling systems:

- Materials handling: palletization, depalletizing, feeding, part removal
- Cleanroom technology: wafer transport, wafer coating
- Warehouse technology: parts picking, storage and retrieval
- Machine tool automation: workpiece loading and unloading, tool changing
- Construction: formwork, placing reinforcing steel bars in concrete
- Process engineering: painting, coating, bonding
- Testing technology: guiding ultrasonic sensors, laboratory equipment

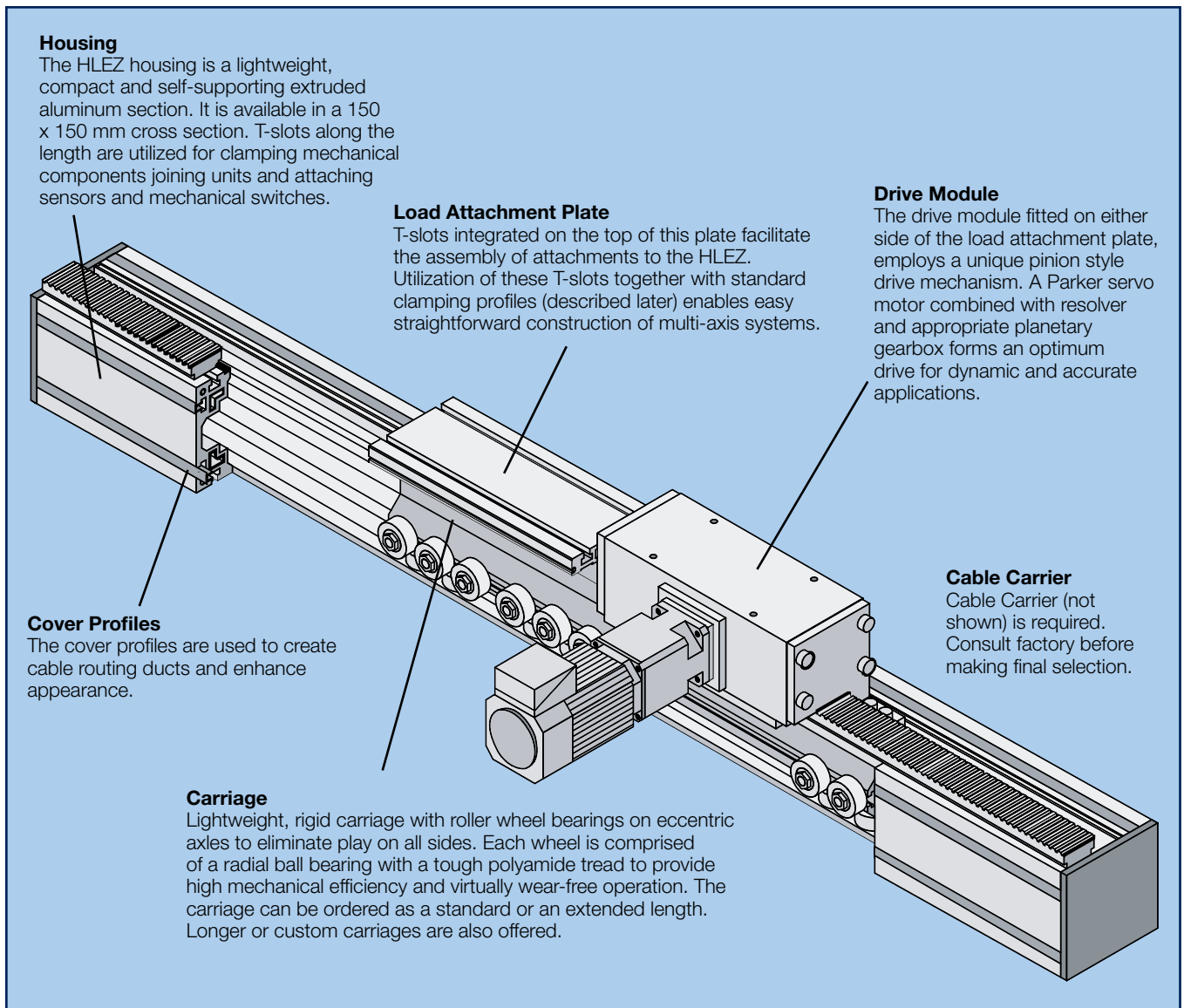

Belt Driven Tables

HLE-Z Series Specifications

Characteristic	Units	HLEZ150	
Unit Weight (basic unit without stroke)			
Standard Carriage, S	kg (lb)	53.0	(116.9)
Extended Carriage, E	kg (lb)	61.0	(134.5)
Carriage Weight			
Standard Carriage, S	kg (lb)	25.7	(56.7)
Extended Carriage, E	kg (lb)	29.7	(65.5)
Weight (per meter) of additional travel length	kg/m (lb/ft)	23.9	(16.6)
Moment of Inertia (related to the drive shaft)			
Standard Carriage, S	kg-cm ² (lb-in ²)	325.0	(111.1)
Extended Carriage, E	kg-cm ² (lb-in ²)	363.4	(124.3)
Travel and Speed			
Maximum Speed	m/s (in/s)	5	(197)
Maximum Acceleration	m/s ² (in/s ²)	10	(393)
Maximum Travel ⁽¹⁾ , NL carriage	m (in)	8.8	(350)
Maximum Travel ⁽¹⁾ , VL carriage	m (in)	8.7	(344)
Maximum Travel - (with splices)	m (in)	50	(1969)
Geometric Data			
Cross Section, Square	mm (in)	150.0	(5.91)
Moment of Inertia Ix	cm ⁴ (in ⁴)	1940.0	(46.61)
Moment of Inertia Iy	cm ⁴ (in ⁴)	2147.0	(51.58)
Moment of Elasticity	N/mm ² (lb/in ²)	0.72 x 10 ⁵	(0.1044 x 10 ⁶)
Pulley Data, Torques, Forces			
Travel Distance per Revolution	mm/rev (in/rev)	200.0	(7.87)
Pulley Diameter	mm (in)	63.6	(2.51)
Maximum Drive Torque ⁽²⁾	Nm (lb-in)	64.0	(566)
Maximum Belt Traction ⁽²⁾ (effective load)	N (lb)	refer to force (Fx) chart on next page	
Repeatability ⁽³⁾	mm (in)	±0.05	(±0.002)

For deviations from the above standards, please contact Parker engineering.

Safety factor taken into consideration S=1. Data applies to a temperature range of between -10°C and +40°C.

(1) Splicing possible for longer travel distances.

(2) Longer life available with wider belt.

(3) Applies to the linear actuator with drive module, without drive.

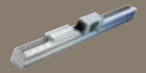

HLE-Z Performance Curves

The forces and torque ratings of the carriage are speed dependent. The curves shown in the graphs apply to a standard carriage (S). With the extended carriage (E), all the values except for F_x (load-bearing capacity of timing belt) can be doubled if the load is applied equally to both halves of the carriage or distributed uniformly along its entire length. The curves show the maximum load-bearing capacity of a carriage in one direction of force or torque. If several loads are applied in different directions, the values given by the curves must be derated, or the load or speed should be reduced if necessary.

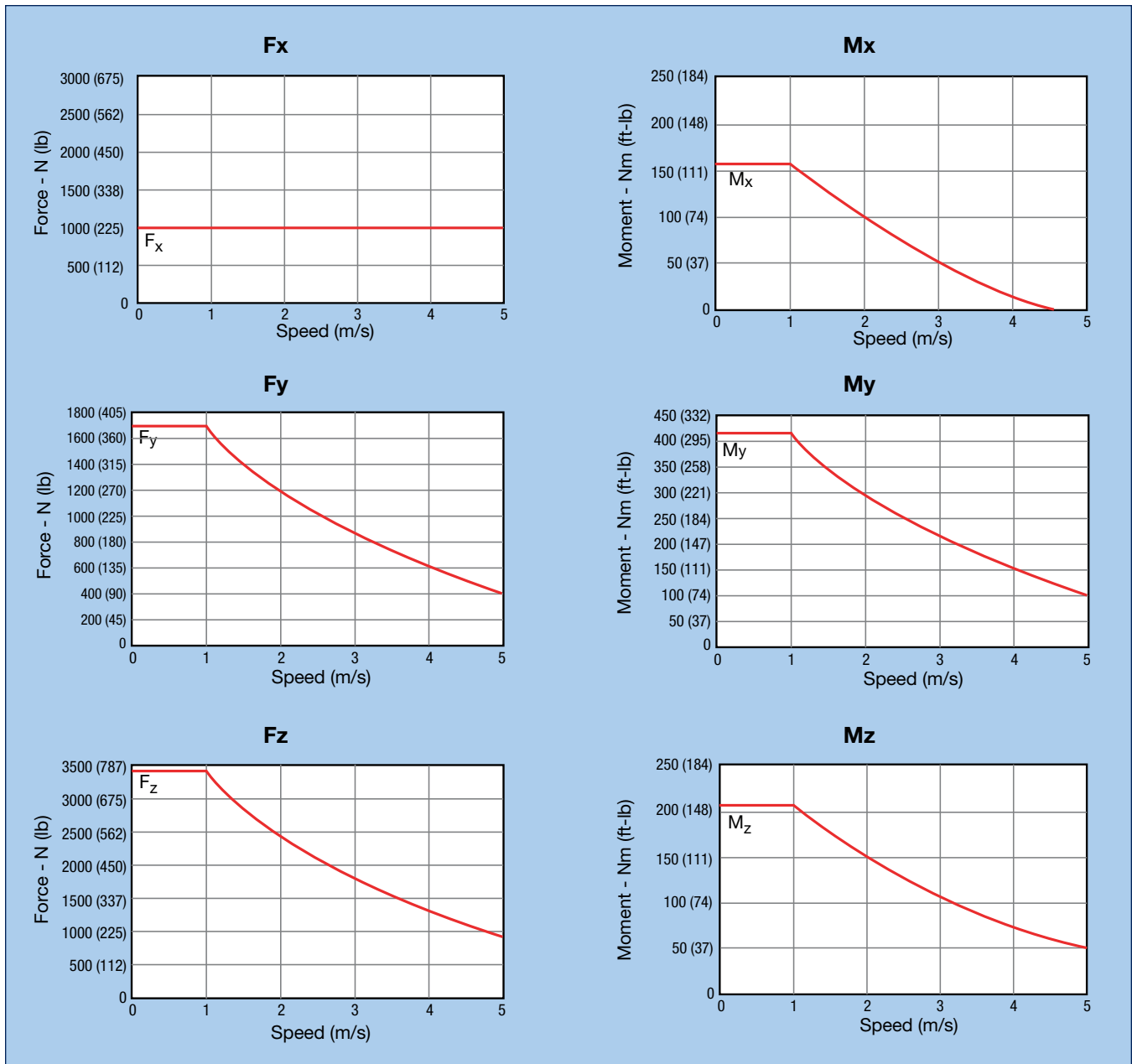
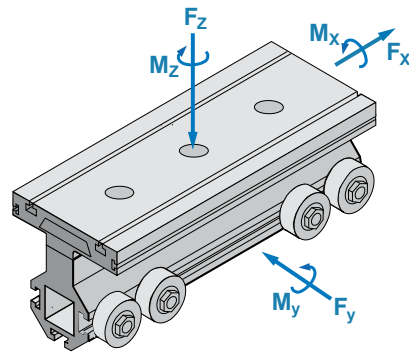

Belt Driven Tables

HLE-Z150 Dimensions

Dimensions (mm)

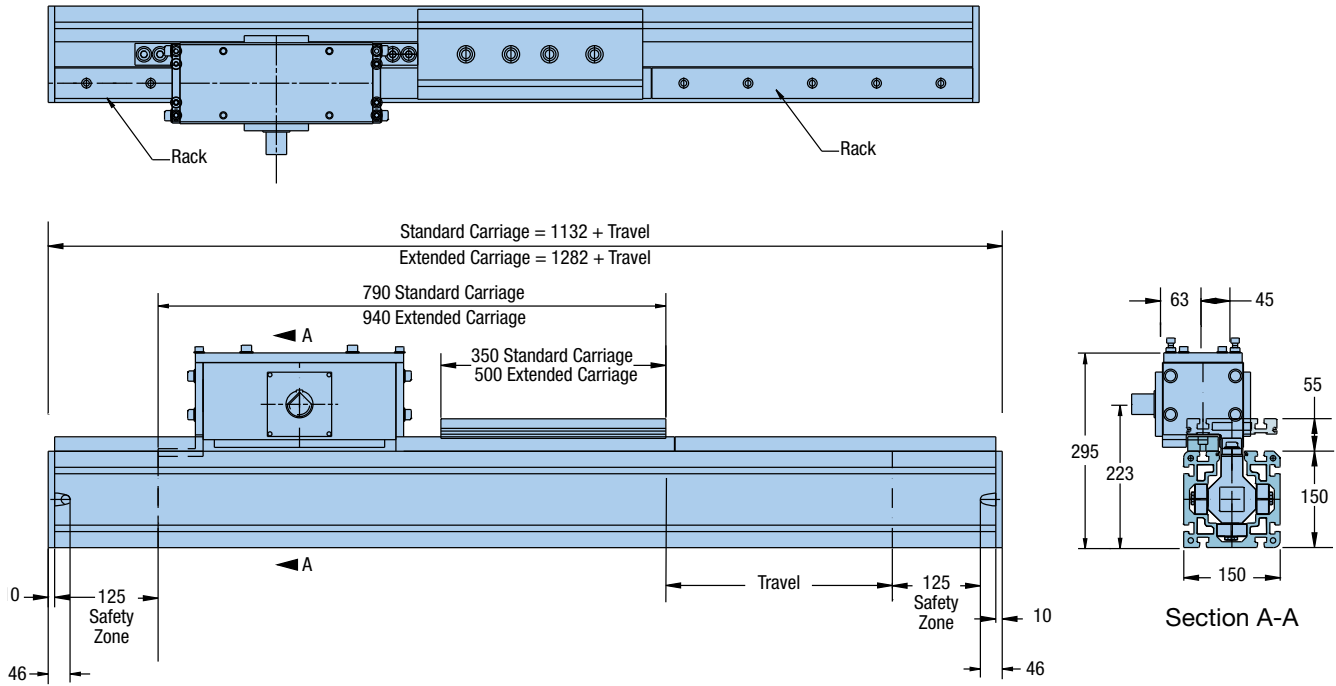

Note: Cable Carrier required (not shown) – consult factory before making final selection.



Fill in an order code from each of the numbered fields to create a complete model order code.

① ② ③ ④ ⑤ ⑥ ⑦ ⑧ ⑨ ⑩ ⑪ ⑫ ⑬ ⑭

Order Example:

HLE Z 150 E P 1000 DL K G4-05 N N N K08 LH0

① **Series**

HLE

② **Model Size**

150

③ **Drive System**

Z Rack-and-pinion
N Idler Unit

④ **Carriage Type**

S Standard Carriage with Load Attachment Plate
E Extended Carriage with Load Attachment Plate

⑤ **Guide System**

P Polyamide Wheels

⑥ **Travel Length**

nnnn Specified travel in mm (nnnn = mm)

⑦ **Drive Shaft Option***

ND No Drive Shaft – Idler Unit
SL Shaft on Left
SR Shaft on Right
DL Gearbox on Left
DR Gearbox on Right

*See illustration below.

⑧ **Drive Shaft Interface**

I No Flange – Idler Unit
K Flange Suitable for 115 mm Gearbox

⑨ **Gearbox Option**

G0-00 No Gearbox
G1-nn Customer Supplied
G2-nn PEN-115*
G3-nn PER-115*
G4-nn GTN-115*
G5-nn GTR-115*

*Single stage ratios: 3, 4, 5, 8, 10; Dual stage ratios: 12, 15, 16, 20, 25

⑩ **Linear Encoder**

N Without Linear Encoder (Standard)
L With Linear Encoder (Consult Factory)

⑪ **Material**

N Standard Version
V Corrosion Resistant Version

⑫ **Strip Seal Cover**

N Without Cover (Standard)

⑬ **Motor Kit Option**

K00 No Motor Kit
K06 J034*, N034*, BE34*, TS3* to GT, PE-115
K07 J090*, N090* to GT, PE-115
K08 M105* to GT, PE-115
K09 ES3*, OEM83-*, ZETA83-*, S83-*, RS3* to GT, PE-115
K10 RS42, RE42, S106-205 to GT, PE-115
K11 S106-178, S106-250 to GT, PE-115
K12 M145 to GT, PE-115
K13 M145 to GT, PE-142

*Single stage ratios: 3, 4, 5, 8, 10; Dual stage ratios: 12, 15, 16, 20, 25

⑭ **Limit/Home Switch Option**

LH0 No Limit Switch Assembly
LH1 Three Mechanical Switches
LH2 Two Mechanical Switches, 1 Prox
LH3 Three NPN Prox Switches, 10-30 VDC
LH4 Three PNP Prox Switches, 10-30 VDC

Indication on left / right: looking from the load plate to the drive module

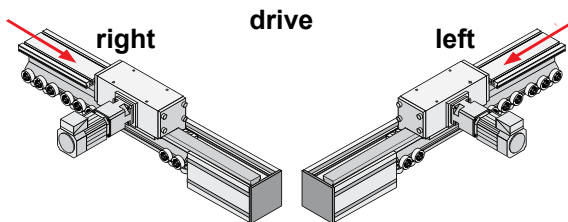

Belt Driven Tables

HZR Series

Features

- Designed as a vertical axis unit
- Load lifting capacities up to 150 kg
- Velocity up to 5 meters/sec.
- Positional repeatability of ± 0.2 mm
- Torsion-resistant housing
- Roller wheel bearings for smooth vertical motion
- High vertical acceleration

The HZR is a rugged vertical axis unit unique to the high speed automation industry. It is specifically designed to satisfy the mechanical demands placed on the vertical axis of a multi-axis gantry robot – utilized for high throughput lifting and transporting of heavy or bulky loads.

The payload is supported by a high strength extruded aluminum profile which is lifted and guided through a torsion-resistant cast aluminum housing. Maintenance-free, heavy duty polyamide bearing wheels evenly distribute and support the high forces induced by rapid horizontal acceleration of the load. A wear-free, steel cord reinforced timing belt transmits large traction forces to provide high accelerations and lifting capability in the vertical direction.

Typical Fields of Application

- Materials handling: palletization, feeding, removal
- Textile machinery building: crosscutting, slitting and stacking, quilting, seam stitching
- Process engineering: painting, coating, bonding
- Storage technology: commissioning, inventory
- Machine tool building: workpiece loading, tool changing
- Testing technology: guiding ultrasonic sensors



HZR Series Specifications

Characteristics	Units	HZR50P (Standard)		HZR50E (Extended)		HZR80		HZR100	
Unit Weight									
Basic Unit (based on 1 meter travel)	kg (lb)	15.3	(33.73)	17.2	(37.92)	37	(81.8)	60	(132.3)
Weight of additional length	kg/m (lb/ft)	2.9	(1.95)	2.9	(1.95)	7.4	(4.9)	10.2	(6.85)
Moment of Inertia (based on 1 meter travel)									
Inertia reflected to drive pulley	kg-cm ² (lb-in ²)	66.11	(22.58)	66.51	(22.72)	250	(85.4)	357	(122.0)
Travel and Speed¹									
Maximum Speed	m/s (in/s)	5	(200)	5	(200)	5	(200)	5	(200)
Maximum Acceleration	m/s ² (in/s ²)	5	(197)	5	(197)	10	(393)	10	(393)
Maximum Travel	m (in)	1.5	(59.1)	1.5	(59.1)	1.5	(59.1)	2.0	(78.7)
Geometric Data									
Cross Section (square profile)	mm (in)	50	(1.97)	50	(1.97)	80	(3.2)	100	(3.9)
Moment of Inertia I _x	cm ⁴ (in ⁴)	29.9	(0.72)	29.9	(0.72)	187.1	(4.5)	383.3	(9.2)
Section Modulus, W	cm ³ (in ³)	29.9	(1.82)	29.9	(1.82)	46.7	(2.85)	76.6	(4.67)
Pulley Data, Torques, Forces									
Travel Distance per Revolution	mm/rev (in/rev)	180	(7.09)	180	(7.09)	240	(9.45)	240	(9.45)
Pulley Diameter	mm (in)	57.3	(2.26)	57.3	(2.26)	76.4	(3.01)	76.4	(3.01)
Maximum Drive Torque	Nm (lb-in)	47	(416.3)	47	(416.3)	108	(956.7)	168	(1488.1)
Static Load	kg (lb)	45	(99.2)	45	(99.2)	75	(165)	150	(331)
Maximum Belt Traction (effective load)	N (lb)	1654	(371.8)	1654	(371.8)	2822	(635)	4410	(992)
Repeatability	mm (in)	±0.2	(±0.008)	±0.2	(±0.008)	±0.2	(±0.008)	±0.2	(±0.008)

1 For higher speeds, accelerations or longer travel consult Parker Application Engineering for assistance.

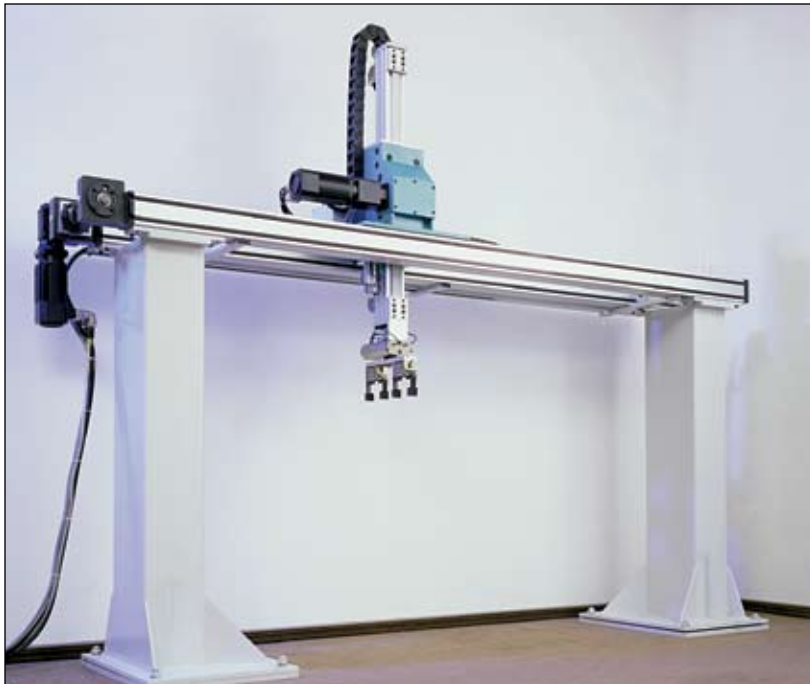

Force and Moment Loads

The forces and moments that the carriage is capable of transferring are speed-dependent. The curves shown in the graphs apply to a standard guiding (P). With the extended guiding (E), all the values apart from F_x (load-bearing capacity of timing belt) can be doubled if the load is applied equally to both halves of the carriage or distributed uniformly along its entire length.

The curves show the maximum load-bearing capacity of a carriage in one direction of force or torque. If several loads are applied in different directions, the values given by the curves must be derated, i.e. the load or speed should be reduced if necessary.

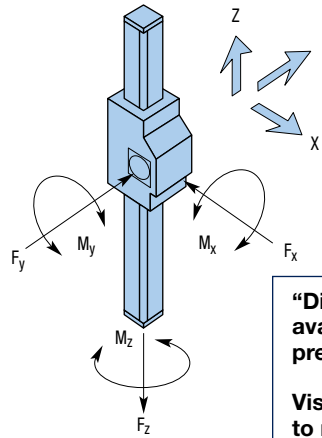

“DimAxes” software is available for determination of precise carriage loading.
Visit www.parkermotion.com to request a Gantry Robot CD.

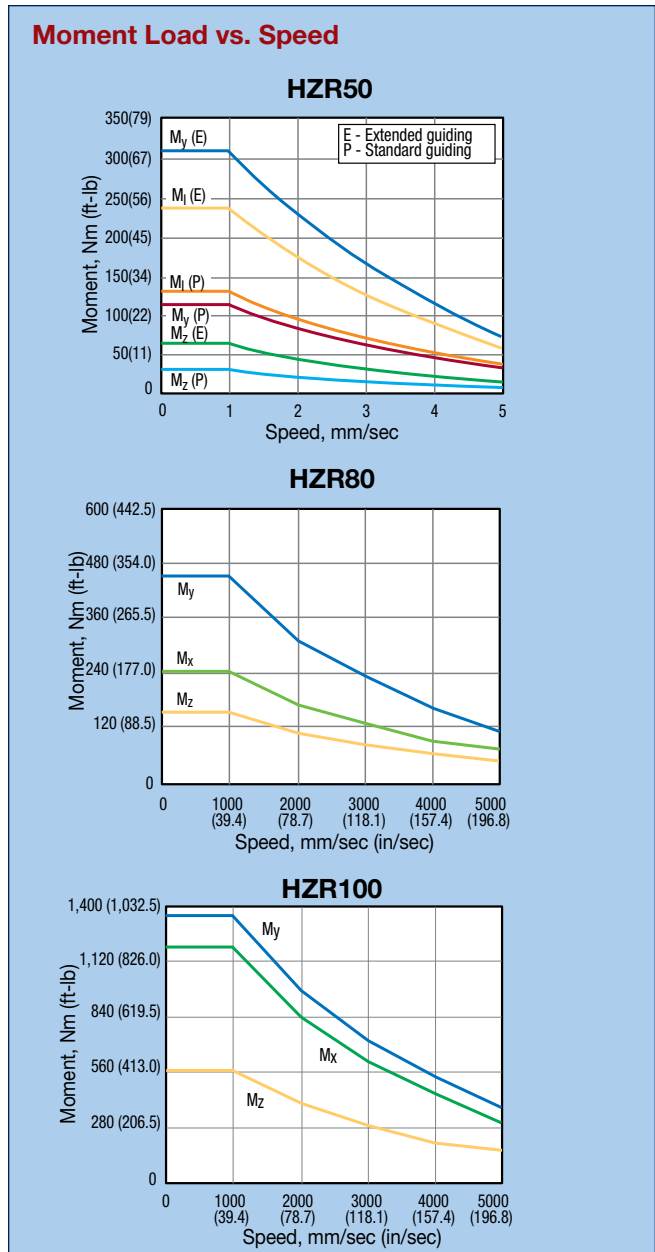
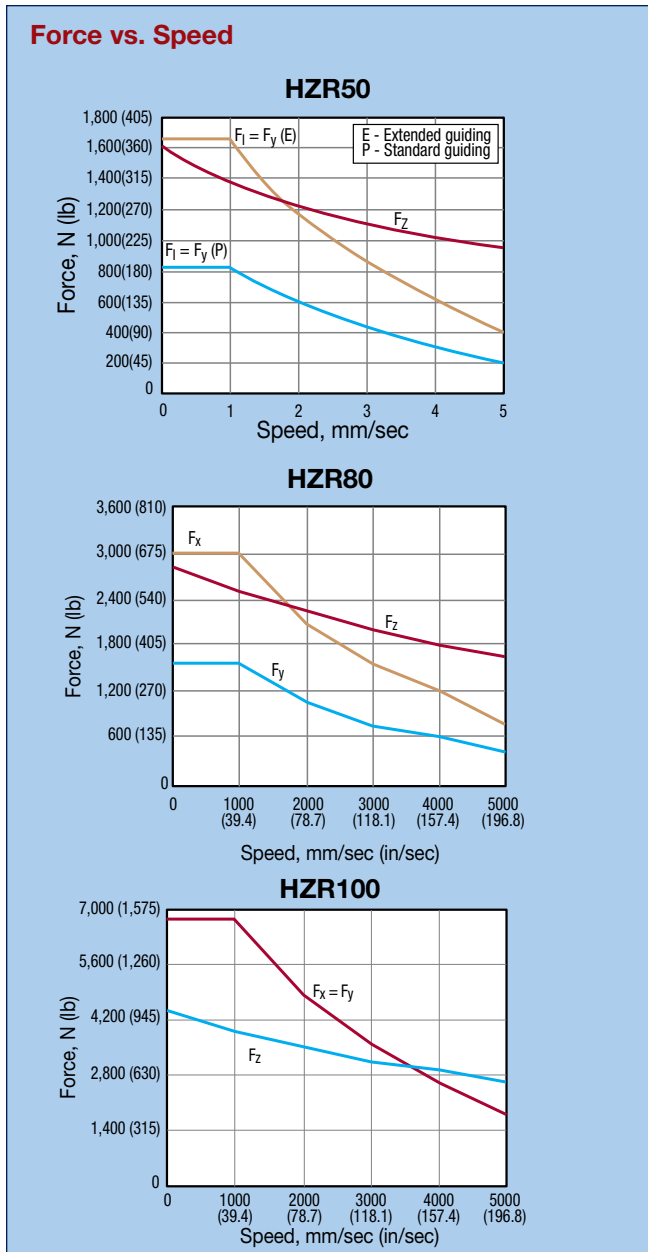

Extension Loads

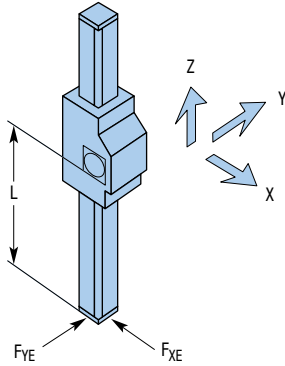

“DimAxes” software is available for determination of precise carriage loading.

Visit www.parkermotion.com to request a Gantry Robot CD.

Force vs. Extended Length

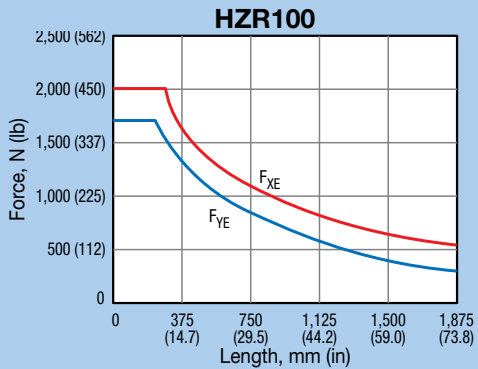
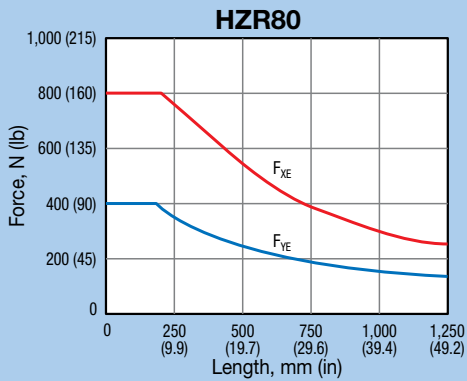
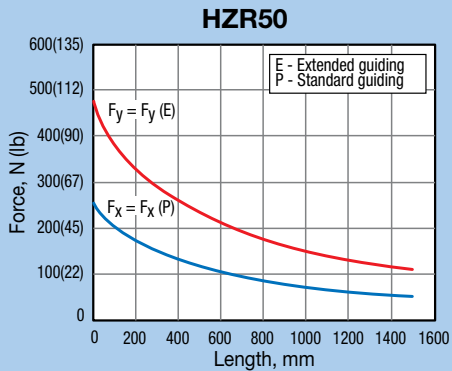

Belt Driven Tables

HZR50

Dimensions (mm)

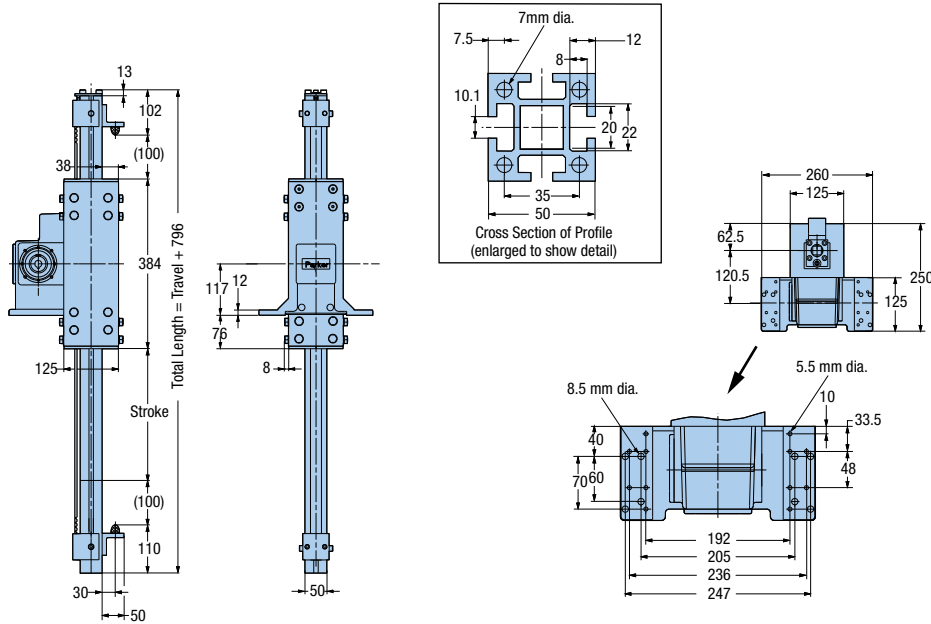

HZR80

HZR100

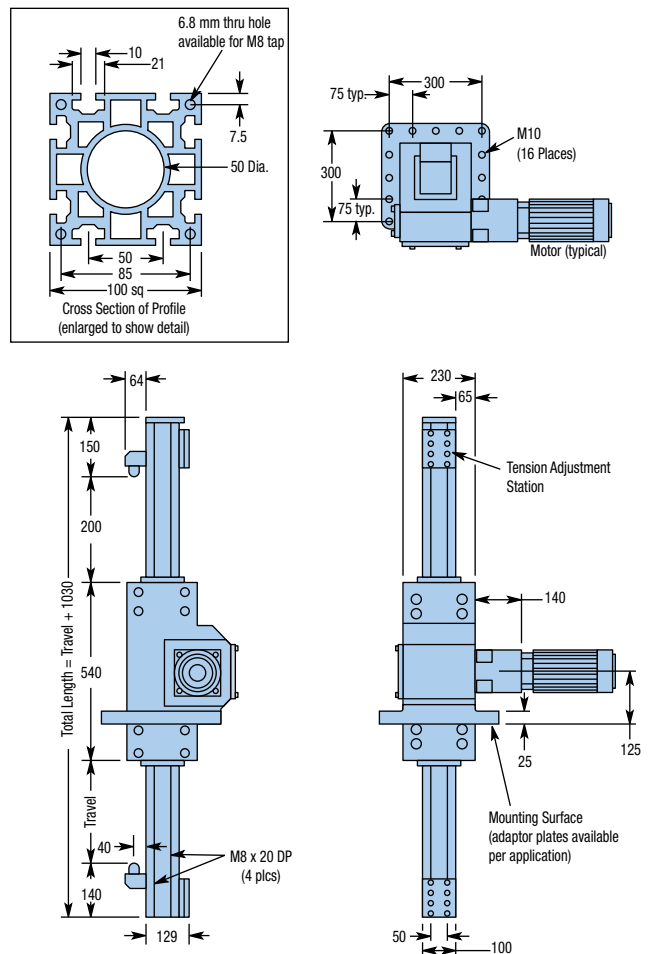
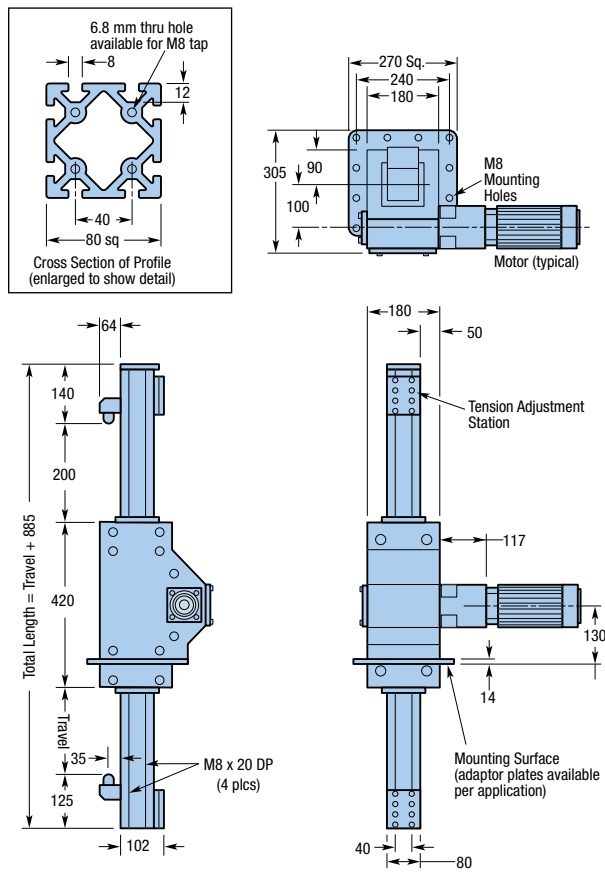

Fill in an order code from each of the numbered fields to create a complete model order code.

	①	②	③	④	⑤	⑥	⑦	⑧	⑨
Order Example:	HZR80	1000	A	SP2	ARO	G2-03	K02	LH1	E

① Series

- HZR50
- HZR80
- HZR100

② Table Travel

nnnn Specified travel in mm (nnnn = mm)

③ Mounting Flange Options

- A No Mounting Flange
- B HZR Mounting to HPLA80
- C HZR Mounting to HLE100
- D HZR Mounting to HPLA120
- E HZR Mounting to HLE150

④ Drive Station Interface

- SP0 Drive Housing Set-Up for GTN090 (HZR50 & HZR80)
- SP2 Drive Housing Set-Up for GTN070 (HZR50)
- SP3 Drive Housing Set-Up for PEN090 (HZR50 & HZR80)
- SP9 Drive Housing Set-Up for GTN/PTN115 (HZR80 & HZR100)

⑤ Orientation Options

- ARO Gearbox Right
- ALO Gearbox Left

⑥ Gearbox Option

- G0-00 No Gearbox
- G1-nn Customer Supplied
- G2-nn GTN070*
- G3-nn GTN090*
- G4-nn GTN115*
- G5-nn PEN090**
- G6-nn PEN115**

*Single stage ratios: 3, 5, 8; Dual stage ratios: 12, 15, 16, 20, 25

**Single stage ratios: 3, 5, 8, 10; Dual stage ratios: 9, 12, 15, 16, 20, 25

⑦ Motor Kit Option

- K00 No Motor Kit
- K01 J034*, N034*, BE34*, TS3* to GTN, PEN-090
- K02 J070*, N070* to GTN, PEN-090
- K03 J090*, N090* to GTN, PEN-090
- K04 M105* to GTN, PEN-090
- K05 ES3*, OEM83-*, ZETA83-*, S83-*, RS3* to GTN, PEN-0-90
- K06 J034*, N034*, BE34*, TS3* to GTN, PEN-115
- K07 J090*, N090* to PE-115 or GTN, PEN-115
- K08 M105* to PE-115 or GTN, PEN-115
- K09 ES3*, OEM83-*, ZETA83-*, S83-*, RS3* to GTN, PEN-115
- K10 RS42, RE42, S106-205 to GTN, PEN-115
- K11 S106-178, S106-250 to GTN, PEN-115
- K12 M145 to GTN, PEN-115
- K13 J070*, N070* to GTN-070
- K14 SM230, SE230, ES2*, OS2, S57-* to GTN-070
- K15 SM, SE 231, 232, 233 to GTN-070 J09*, N09* to GTN-070 J090*
- K16 N090* to GTN-070

⑧ Limit Switch Assembly

- LH0 No Switch Assembly
- LH1 Three mechanical switches, with 1 NO and 1 NC contact per switch (HZR80 and HZR100)
- LH2 Two mechanical switches and 1 NPN proximity switch (HZR80 and HZR100)
- LH3 Three NPN proximity switches NO/NC, 10-30 VDC (HZR80 and HZR100)
- LH4 Three PNP proximity switches NO/NC, 10-30 VDC (HZR80 and HZR100)
- LH5 Three NPN proximity switches NO "Home"; NC Travel Limits 10-30 VDC (HZR50 only)
- LH6 Three NPN proximity switches NO "Home"; NC Travel Limits 10-30 VDC (HZR50 only)

⑨ Extended Option

- E 16 Additional Rollers (HZR50 only)

Belt Driven Tables

BLMA Linear Motor Driven Module

Features

- Linear Servo Motor Drive
- $\pm 10.0 \mu\text{m}$ positional repeatability
- Velocity up to 7 meters/sec.
- Acceleration to 5 g's
- IP30 seal strip
- Standard travels to 6 meters



Parker's BLMA120 linear servo motor actuator offers high end, direct drive performance to the industrial actuator world for material handling and similar applications that require higher accelerations, higher speeds, instant settling, and precise positioning over long travels. (BLMA = Balanced Linear Motor Actuator). The BLMA is a plug and play linear motor actuator which houses a powerful linear servo motor (380 pounds of peak thrust) in a high strength rigid aluminum body to enable high end performance over long unsupported spans.

The direct, non-contact drive design eliminates the need for mechanical transmission components, creating several advantages:

- A low system mass moment of inertia, and as a result high acceleration and speed capability.
- The elimination of losses due to mechanics means higher system accuracy.
- Stiffness is improved through the elimination of mechanical components and their inherent sloppiness.
- Long service life, as there is no mechanical wear associated with the non-contact transmission of force.
- Quiet operation.

The external dimensions of the BLMA are identical to those of the belt-driven HPLA120, making it easy to combine with other Parker linear drive products. The linear motor is completely internal, and an IP30 steel strip seal protects the linear motor from dust and debris. An integrated SinCos linear encoder ensures the highest repeatability. The linear bearing system consists of proven polyamide-covered roller bearing wheels that are lubricated for life. Wheel play is eliminated through the use of eccentric adjustments on all sides. Two mounting grooves reside on both sides and on the underside of the bearing extrusion. The grooves allow the mounting of additional mechanical components as well as additional linear motion axes. Additional forcer-carriages on a single axis are possible.

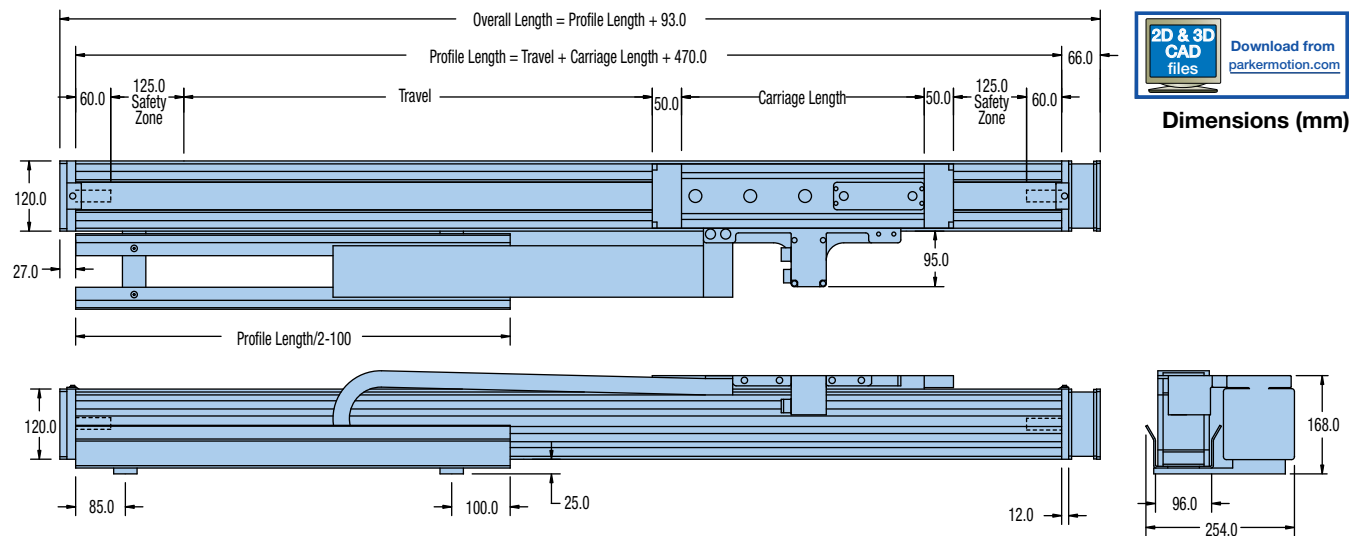



BLMA Table Specifications

	Units	12 Pole				20 Pole			
		Series		Parallel		Series		Parallel	
		Polyamide Wheels	Steel Wheels	Polyamide Wheels	Steel Wheels	Polyamide Wheels	Steel Wheels	Polyamide Wheels	Steel Wheels
Nominal Speed	m/s (in/s)	5 (200)		5 (200)		5 (200)		5 (200)	
Peak Speed	m/s (in/s)	7 (280)		7 (280)		7 (280)		7 (280)	
Nominal Acceleration	m/s ² (in/s ²)	20 (786)		20 (786)		20 (786)		20 (786)	
Peak Acceleration	m/s ² (in/s ²)	50 (1965)		50 (1965)		50 (1965)		50 (1965)	
Carriage Length	mm (in)	515 (20.3)	45 (1.5)	695 (27.4)	725 (28.5)	680 (26.8)	710 (28.0)	860 (33.9)	890 (35.0)
Maximum Stroke	mm (in)	6329 (249)	6299 (248)	6149 (242)	6119 (240)	6164 (242)	6134 (241)	5984 (235)	5954 (234)
Carriage Weight	kg (lb)	11.6 (25.5)		14.2 (31.2)		16.3 (35.9)		18.9 (41.6)	
Weight of Base Unit	kg (lb)	25.7 (56.5)		27.9 (61.4)		32.8 (72.2)		35.0 (77.0)	
Static Friction	N	30 (6.7)		30 (6.7)		30 (6.7)		30 (6.7)	
Damping	N/m/s (lb/in/s)	15 (0.086)		25 (0.143)		15 (0.086)		25 (0.143)	
Repeatability	µm (in ⁻³)	±10 (0.4)		±10 (0.4)		±10 (0.4)		±10 (0.4)	
Ambient Temperature	°C	5 to 30		5 to 30		5 to 30		5 to 30	

BLMA Motor Specifications

	Units	12 Pole				20 Pole			
		Series		Parallel		Series		Parallel	
		Polyamide Wheels	Steel Wheels	Polyamide Wheels	Steel Wheels	Polyamide Wheels	Steel Wheels	Polyamide Wheels	Steel Wheels
Continuous Force, Water Cooled	N (lb)	419 (94)	520 (117)	419 (94)	520 (117)	689 (155)	844 (190)	689 (155)	844 (190)
Continuous Current, Water Cooled	A	6.5	8.0	13.0	16.1	11.9	14.6	23.8	29.1
Continuous Force, Air Cooled	N (lb)	310 (70)	385 (87)	310 (70)	385 (87)	510 (115)	625 (141)	510 (115)	625 (141)
Continuous Current, Air Cooled	A	4.8	6.0	9.6	11.9	8.8	10.8	17.6	21.6
Peak Force	N (lb)	892 (200)	892 (200)	892 (200)	892 (200)	1693 (380)	1693 (380)	1693 (380)	1693 (380)
Peak Current	A	16.8	16.8	33.6	33.6	30.8	30.8	61.6	61.6
Resistance	Ohm	4.2	4.2	1.05	1.05	2.8	2.8	0.7	0.7
Inductance	mH	23.85	23.85	5.96	5.96	13.09	13.09	3.27	3.27
Back EMF	V/m/s (V/in/s)	59 (1.5)	59 (1.5)	30 (0.8)	30 (0.8)	59 (1.5)	59 (1.5)	30 (0.8)	30 (0.8)
Resolver Offset	degrees	58	58	58	58	58	58	58	58
Max. Coil Temperature	°C	90	130	90	130	90	130	90	130
Carriage Temperature	°C	55	75	55	75	65	95	65	95
Magnetic Pitch Motor	mm (in)	42 (1.654)	42 (1.654)	42 (1.654)	42 (1.654)	42 (1.654)	42 (1.654)	42 (1.654)	42 (1.654)
Feedback	-	SinCos	SinCos	SinCos	SinCos	SinCos	SinCos	SinCos	SinCos
Magnetic Pitch (feedback)	mm (in)	1 (0.0394)	1 (0.0394)	1 (0.0394)	1 (0.0394)	1 (0.0394)	1 (0.0394)	1 (0.0394)	1 (0.0394)
Time at Peak Current	sec	5	5	5	5	5	5	5	5
Recommended Compax 3 Power Level*		S063V2 or S075V4		S150V4		S150V4		S300V4	

*Refer to the Drive and Controllers section for Compax 3 Drive Information

Belt Driven Tables



Parker Gantry Systems Minimize Your Engineering Effort

Parker's gantry systems provide cost-effective, easy to integrate solutions that satisfy the vast majority of automation requirements. In addition to our standard gantry systems, Parker offers products with additional capabilities to fulfill the needs of special applications. Our engineering skill and manufacturing expertise have integrated these products into custom-tailored gantry solutions which have successfully addressed the most unique and exacting requirements of machine builders and integrators around the world.

Additional Capabilities

- Motors, Drives and Controls
- Extended Travels
- Rotary Motion Modules
- Cleanroom Preparations
- External Position Feedback
- Vertical Axis Brakes
- End Effectors
- Protective Guarding
- Custom Support Structures

Gantry Robot Elements

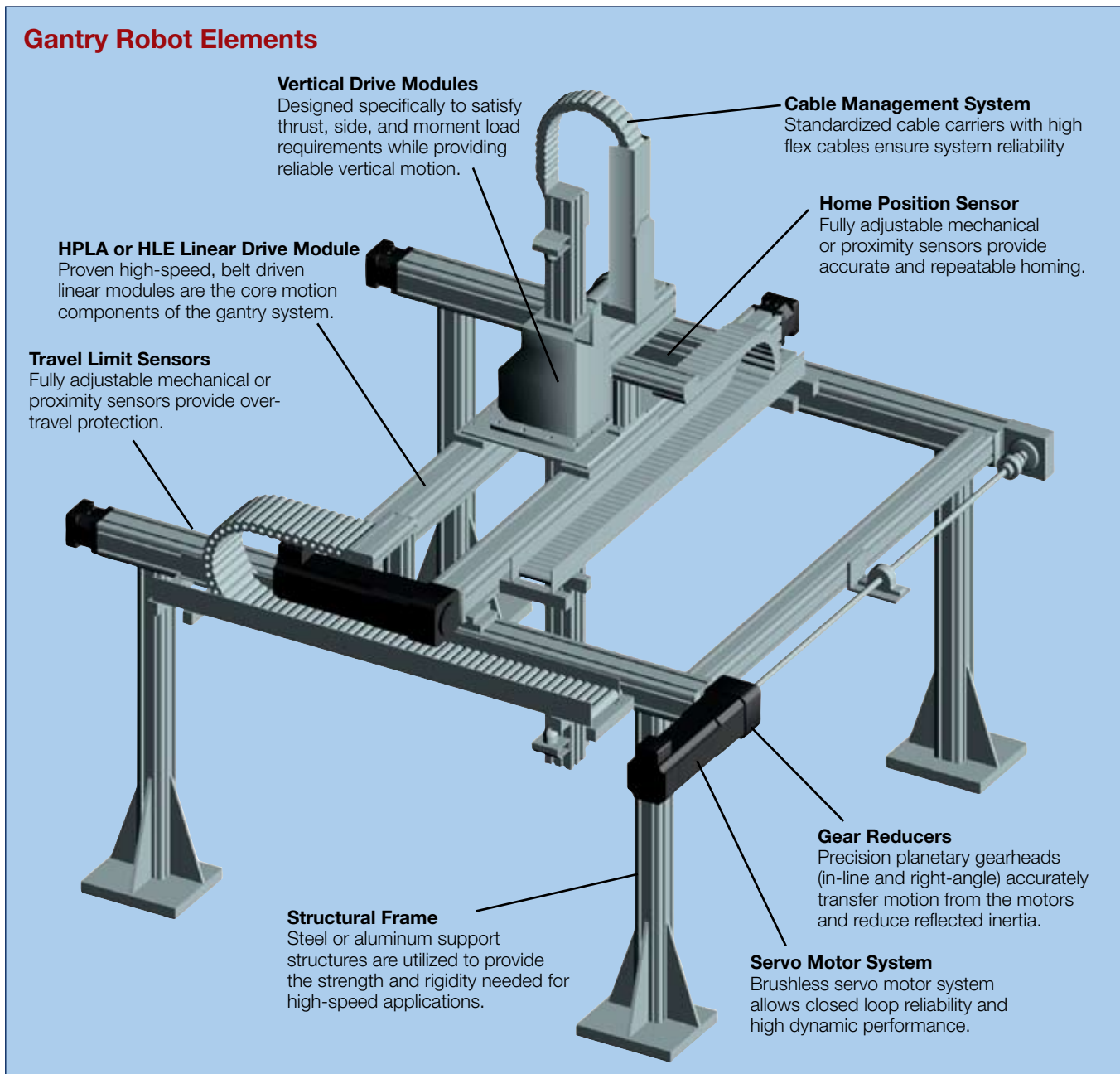



Parker's seven standard system configurations are designed to satisfy the vast majority of gantry robot applications. By standardizing on these configurations, Parker has simplified sizing and selection, shortened lead times, and reduced costs for users of these systems. The travels and loads indicated are nominal, and should not be considered limiting factors. Longer travels and increased loads are attainable depending upon the combination of parameters.

System One

Two Axis: $XX' - Y$



System Four

Two Axis: $XX' - Z$



System Five

Two Axis: $XX' - Z$



System Two

Two Axis: $XX' - YY'$



System Six

Three Axis: $XX' - YY' - Z$

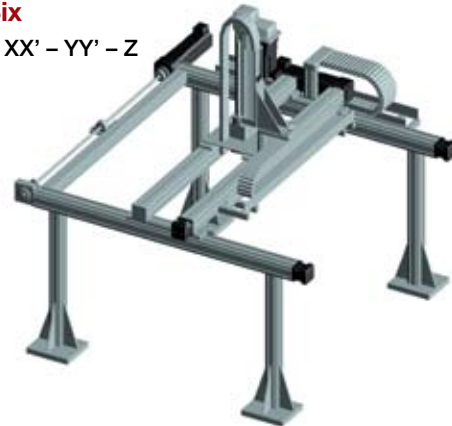

System Three

Two Axis: $XX' - Z$



System Seven

Three Axis: $XX' - YY' - Z$

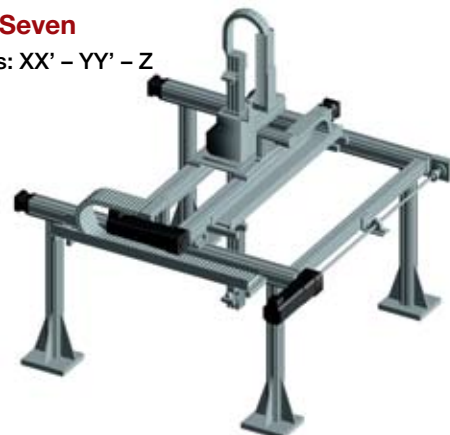

Belt Driven
Tables

System One

System One provides two axes of horizontal motion. The primary axis (X) is comprised of two HPLA or HLE Linear Modules linked by a common drive shaft, and the secondary axis (Y) is comprised of one HPLA or HLE Linear Module. These linear modules are capable of high speeds and accelerations over long travels. This system is designed for rapid transport of light to moderate loads in a single horizontal plane.

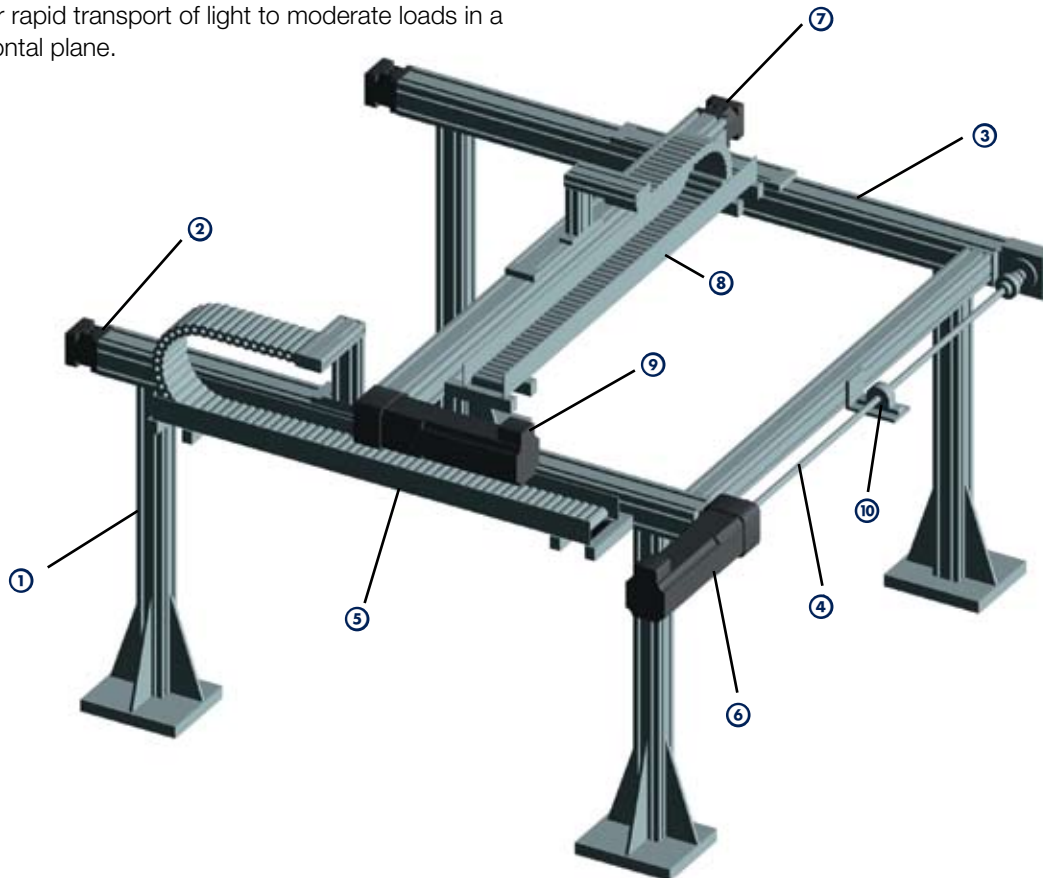
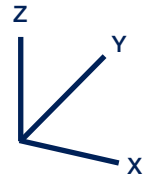

- ① Support Structure Available (steel or aluminum framing)
- ② X-Axis Drive Rail Assembly
- ③ X-Axis Driven Rail Assembly
- ④ X-Axis Link Shaft Assembly
- ⑤ X-Axis Cable Carrier
- ⑥ X-Axis Drive Motor
- ⑦ Y-Axis Drive Rail Assembly
- ⑧ Y-Axis Cable Carrier
- ⑨ Y-Axis Drive Motor
- ⑩ Pillow Block Bearing & Support (Based on Application)

Series No.	Axis Model Number			Load (kg)	Travel			Velocity		
	X-Axis	Y-Axis	Z-Axis		X-Axis (meters)	Y-Axis (meters)	Z-Axis (meters)	X-Axis (m/sec.)	Y-Axis (m/sec.)	Z-Axis (m/sec.)
1	HLE60RB	HLE60RB	—	15	2.9	1.3	—	2.0	2.0	—
2	HLE60SR	HLE60SR	—	25	2.8	1.3	—	2.0	2.0	—
3	HPLA080	HPLA080	—	30	5.4	2.0	—	2.0	3.0	—
4	HLE100RB	HLE100RB	—	35	6.0	2.0	—	2.0	3.0	—
5	HLE100SR	HLE100SR	—	75	6.0	2.0	—	2.0	3.0	—
6	HPLA120	HPLA120	—	85	9.3	3.0	—	2.0	3.0	—
7	HLE150RB	HLE150RB	—	100	7.9	3.0	—	2.0	3.0	—

Note: Loads, travels, and velocities shown are interdependent. Increased values are attainable.





Dimensions

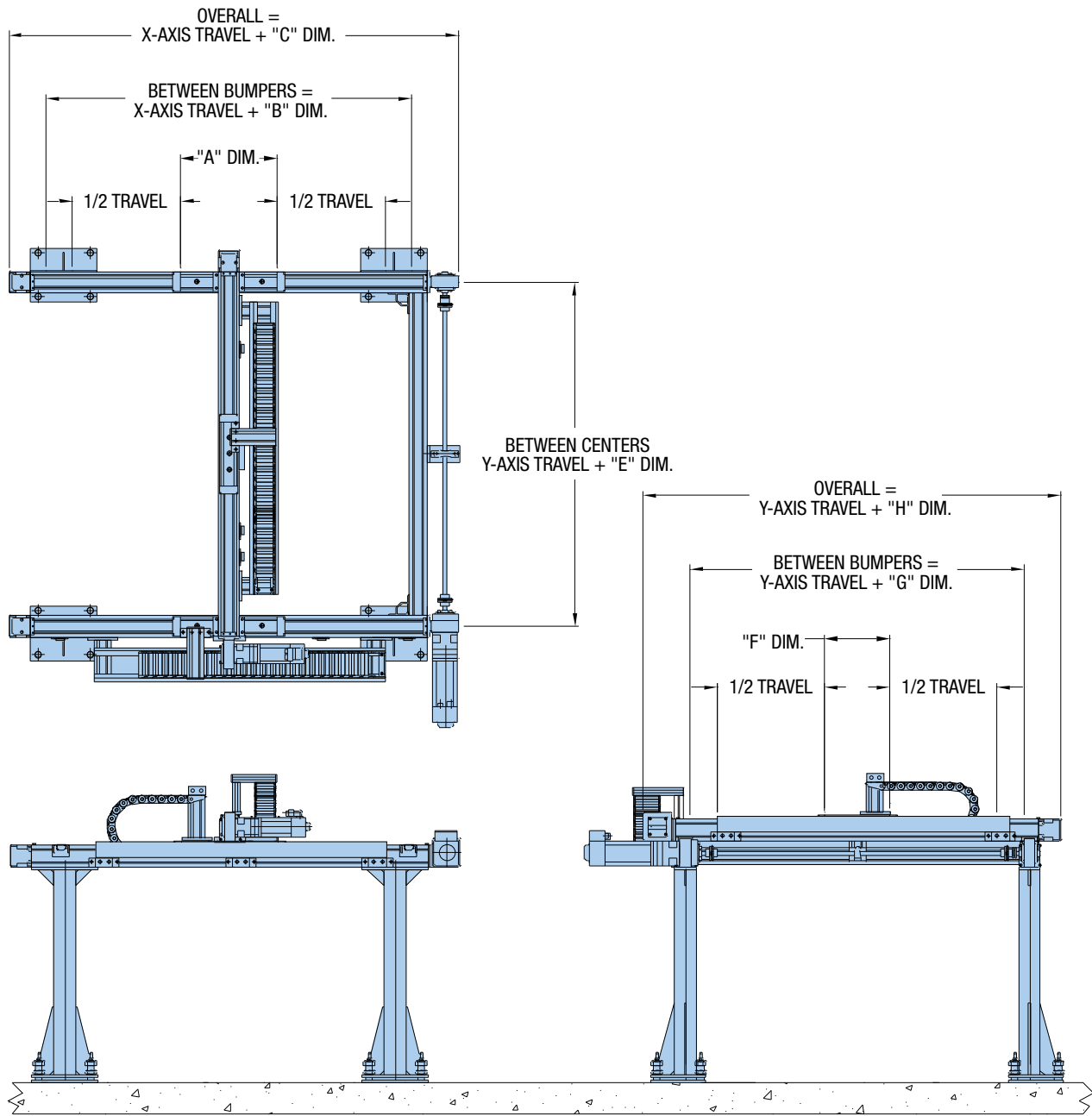

Belt Driven Tables

System One (XX' - Y)							
Series No.	"A" Dim mm (in.)	"B" Dim mm (in.)	"C" Dim mm (in.)	"E" Dim mm (in.)	"F" Dim mm (in.)	"G" Dim mm (in.)	"H" Dim mm (in.)
1	254.0 (10.00)	504.0 (19.84)	730.0 (28.74)	406.2 (15.99)	152.4 (6.00)	402.4 (15.84)	628.4 (24.74)
2	254.0 (10.00)	504.0 (19.84)	720.0 (28.35)	380.2 (14.97)	152.4 (6.00)	402.4 (15.84)	618.0 (24.33)
3	400.0 (15.75)	650.0 (25.59)	1012.0 (39.84)	530.0 (20.87)	250.0 (9.84)	500.0 (19.69)	862.0 (33.94)
4	450.0 (17.72)	700.0 (27.56)	1090.0 (42.91)	588.0 (23.15)	300.0 (11.81)	550.0 (21.65)	940.0 (37.01)
5	450.0 (17.72)	700.0 (27.56)	1141.0 (44.92)	605.0 (23.82)	300.0 (11.81)	550.0 (21.65)	991.0 (39.02)
6	500.0 (19.69)	750.0 (29.53)	1205.0 (47.44)	560.0 (22.05)	300.0 (11.81)	550.0 (21.65)	1005.0 (39.57)
7	500.0 (19.69)	750.0 (29.53)	1220.0 (48.03)	612.0 (24.09)	350.0 (13.78)	600.0 (23.62)	1070.0 (42.13)

System Two

System Two utilizes two linear modules in both axes (X & Y). The second linear module of the Y-axis is an idler unit which increases load capacity (normal and moment) and permits longer travel. The addition of this unit doubles the load capacity over System One. Traction force can be improved by linking the second axis (Y) module to the first with a common drive shaft. The link shaft doubles the potential acceleration of the system. This system is intended for moderate to heavy loads.

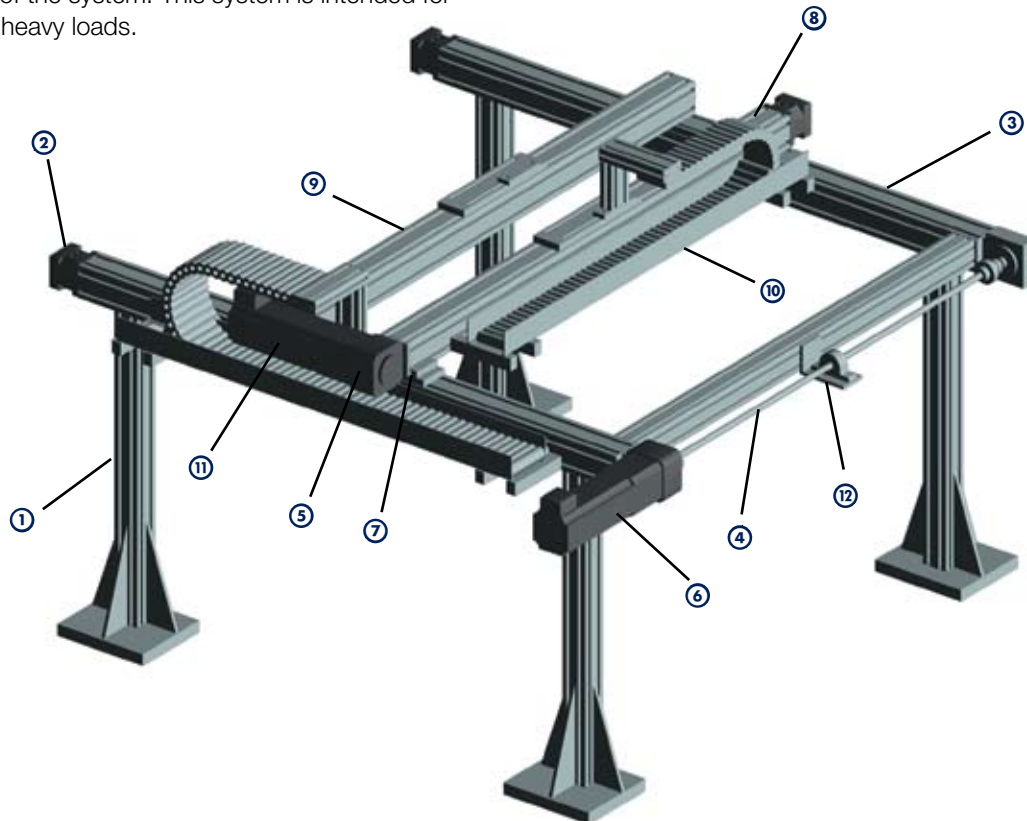
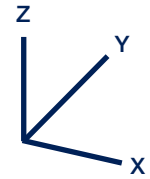

- ① Support Structure Available (steel or aluminum framing)
- ② X-Axis Drive Rail Assembly
- ③ X-Axis Driven Rail Assembly
- ④ X-Axis Link Shaft Assembly
- ⑤ X-Axis Cable Carrier
- ⑥ X-Axis Drive Motor
- ⑦ Clamping Profile
- ⑧ Y-Axis Drive Rail Assembly
- ⑨ Y-Axis Idler Rail Assembly
- ⑩ Y-Axis Cable Carrier
- ⑪ Y-Axis Drive Motor
- ⑫ Pillow Block Bearing & Support (Based on Application)

Series No.	Axis Model Number			Load (kg)	Travel (meters)			Velocity (m/sec.)		
	X-Axis	Y-Axis	Z-Axis		X-Axis	Y-Axis	Z-Axis	X-Axis	Y-Axis	Z-Axis
1	HLE60RB	HLE60RB	—	30	2.9	1.3	—	1.0	2.0	—
2	HLE60SR	HLE60SR	—	50	2.8	1.3	—	1.0	2.0	—
3	HPLA080	HPLA080	—	60	5.4	2.0	—	2.0	3.0	—
4	HLE100RB	HLE100RB	—	70	6.0	2.0	—	1.5	4.0	—
5	HLE100SR	HLE100SR	—	150	6.0	2.0	—	1.5	4.0	—
6	HPLA120	HPLA120	—	170	9.3	3.0	—	2.0	4.0	—
7	HLE150RB	HLE150RB	—	200	7.9	3.0	—	2.0	4.0	—

Note: Loads, travels, and velocities shown are interdependent. Increased values are attainable.





Dimensions

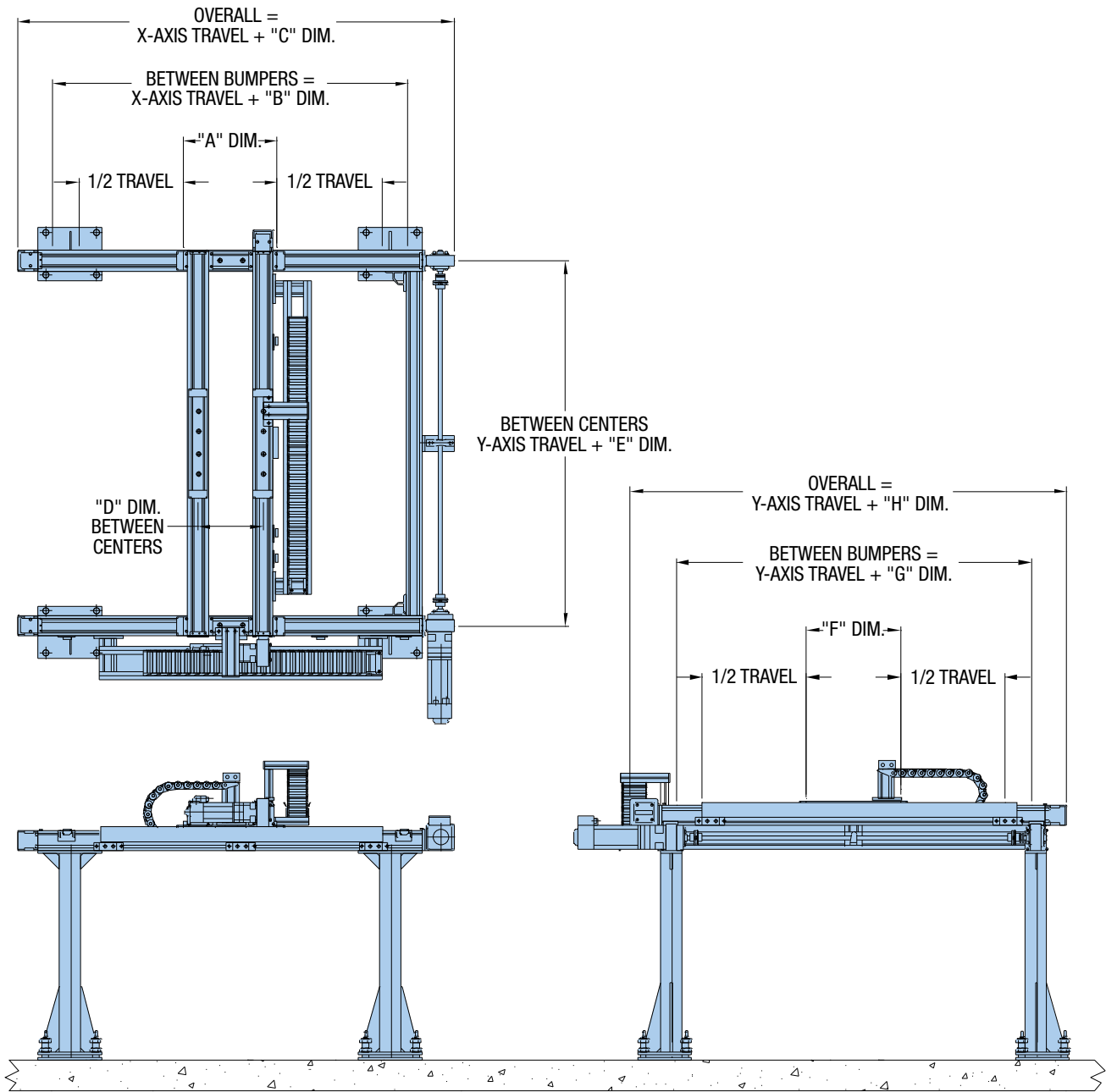

Belt Driven Tables

Series No.	System Two (XX' - YY')							
	"A" Dim mm (in)	"B" Dim mm (in)	"C" Dim mm (in)	"D" Dim mm (in)	"E" Dim mm (in)	"F" Dim mm (in)	"G" Dim mm (in)	"H" Dim mm (in)
1	254.0 (10.00)	504.0 (19.84)	730.0 (28.74)	169.8 (6.69)	508.2 (20.01)	254.0 (10.00)	504.0 (19.84)	730.0 (28.74)
2	254.0 (10.00)	504.0 (19.84)	720.0 (28.35)	169.8 (6.69)	482.2 (18.98)	254.0 (10.00)	504.0 (19.84)	720.0 (28.35)
3	400.0 (15.75)	650.0 (25.59)	1012.0 (39.84)	280.0 (11.02)	680.0 (26.77)	400.0 (15.75)	650.0 (25.59)	1012.0 (39.84)
4	450.0 (17.72)	700.0 (27.56)	1090.0 (42.91)	310.0 (12.21)	738.0 (29.06)	450.0 (17.72)	700.0 (27.56)	1090.0 (42.91)
5	450.0 (17.72)	700.0 (27.56)	1141.0 (44.92)	310.0 (12.21)	755.0 (29.72)	450.0 (17.72)	700.0 (27.56)	1141.0 (44.92)
6	500.0 (19.69)	750.0 (29.53)	1205.0 (47.44)	330.0 (12.99)	760.0 (29.92)	500.0 (19.69)	750.0 (29.53)	1205.0 (47.44)
7	500.0 (19.69)	750.0 (29.53)	1220.0 (48.03)	300.0 (11.81)	762.0 (30.00)	500.0 (19.69)	750.0 (29.53)	1220.0 (48.03)

System Three

System Three provides two axes of motion in a vertical plane. A ballscrew driven ET Cylinder is utilized to provide high thrust in the vertical direction. ET Rod Guides, in conjunction with the dual X-axis, minimize the effects of moment and side loading, permitting higher acceleration of the payload.

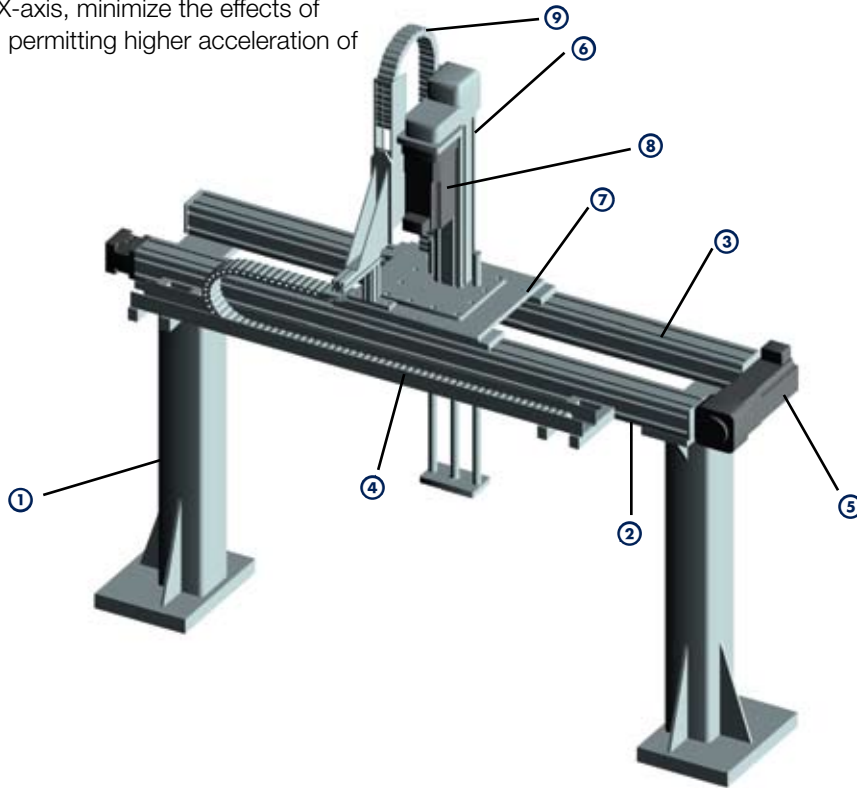
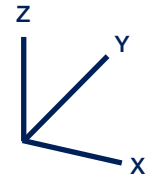

- ① Support Structure Available (steel or aluminum framing)
- ② X-Axis Drive Rail Assembly
- ③ X-Axis Idler Rail Assembly
- ④ X-Axis Cable Carrier
- ⑤ X-Axis Drive Motor
- ⑥ ET Cylinder Z-Axis with Flange Plate
- ⑦ Z-Axis Mounting Plate
- ⑧ Z-Axis Drive Motor
- ⑨ Z-Axis Cable Carrier

Series No.	Axis Model Number			Load (kg)	Travel			Velocity		
	X-Axis	Y-Axis	Z-Axis		X-Axis (meters)	Y-Axis (meters)	Z-Axis (meters)	X-Axis (m/sec.)	Y-Axis (m/sec.)	Z-Axis (m/sec.)
1	HLE60RB	—	ETB32	10	2.9	—	0.3	1.5	—	0.5
2	HLE60RB	—	ETB50	20	2.9	—	0.5	1.5	—	0.8
3	HLE60SR	—	ETB32	10	2.8	—	0.3	1.5	—	0.5
4	HLE60SR	—	ETB50	20	2.8	—	0.5	1.5	—	0.8
5	HPLA080	—	ETB50	35	5.4	—	0.5	2.0	—	0.8
6	HLE100RB	—	ETB50	40	6.0	—	0.5	2.0	—	0.8
7	HLE100RB	—	ETB80	50	6.0	—	1.0	2.0	—	0.5
8	HLE100SR	—	ETB50	40	6.0	—	0.5	2.0	—	0.5
9	HLE100SR	—	ETB80	50	6.0	—	1.0	2.0	—	0.5
10	HPLA120	—	ETB80	75	9.3	—	1.0	2.5	—	0.5
11	HPLA120	—	ETB100	100	9.3	—	1.0	2.5	—	1.0
12	HLE150RB	—	ETB80	75	7.9	—	1.0	2.5	—	0.5
13	HLE150RB	—	ETB100	100	7.9	—	1.0	2.5	—	1.0

Note: Loads, travels, and velocities shown are interdependent. Increased values are attainable.



Dimensions

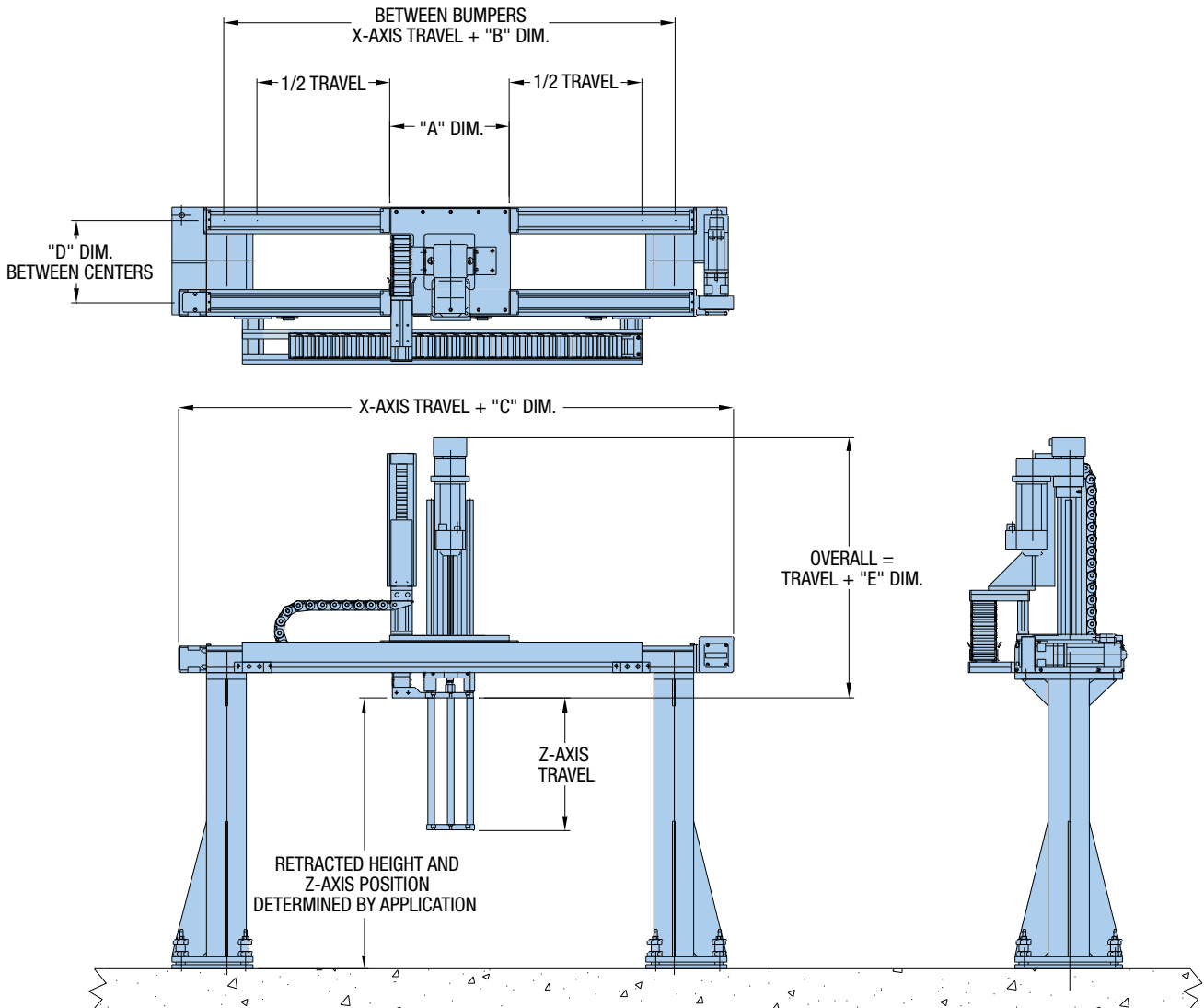

Belt Driven Tables

System Three XX' – Z (Electric Cylinder)					
Series No.	"A" Dim mm (in.)	"B" Dim mm (in.)	"C" Dim mm (in.)	"D" Dim mm (in.)	"E" Dim mm (in.)
1	254.0 (10.00)	504.0 (19.84)	730.0 (28.74)	200.0 (7.87)	238.0 (9.37)
2	254.0 (10.00)	504.0 (19.84)	730.0 (28.74)	200.0 (7.87)	304.1 (11.97)
3	254.0 (10.00)	504.0 (19.84)	720.0 (28.35)	200.0 (7.87)	238.0 (9.37)
4	254.0 (10.00)	504.0 (19.84)	720.0 (28.35)	200.0 (7.87)	304.1 (11.97)
5	400.0 (15.75)	650.0 (25.59)	1012.0 (39.84)	250.0 (9.84)	304.1 (11.97)
6	450.0 (17.72)	700.0 (27.56)	1090.0 (42.91)	300.0 (11.81)	304.1 (11.97)
7	450.0 (17.72)	700.0 (27.56)	1090.0 (42.91)	300.0 (11.81)	321.9 (12.67)
8	450.0 (17.72)	700.0 (27.56)	1141.0 (44.92)	300.0 (11.81)	304.1 (11.97)
9	450.0 (17.72)	700.0 (27.56)	1141.0 (44.92)	300.0 (11.81)	321.9 (12.67)
10	500.0 (19.69)	750.0 (29.53)	1205.0 (47.44)	350.0 (13.78)	321.9 (12.67)
11	500.0 (19.69)	750.0 (29.53)	1205.0 (47.44)	350.0 (13.78)	494.0 (19.45)
12	500.0 (19.69)	750.0 (29.53)	1220.0 (48.03)	350.0 (13.78)	321.9 (12.67)
13	500.0 (19.69)	750.0 (29.53)	1220.0 (48.03)	350.0 (13.78)	494.0 (19.45)



System Four

System Four is a variation of System Three that offers an alternative mounting arrangement. It is a popular choice for front loading applications and is often implemented as a wall mount unit.

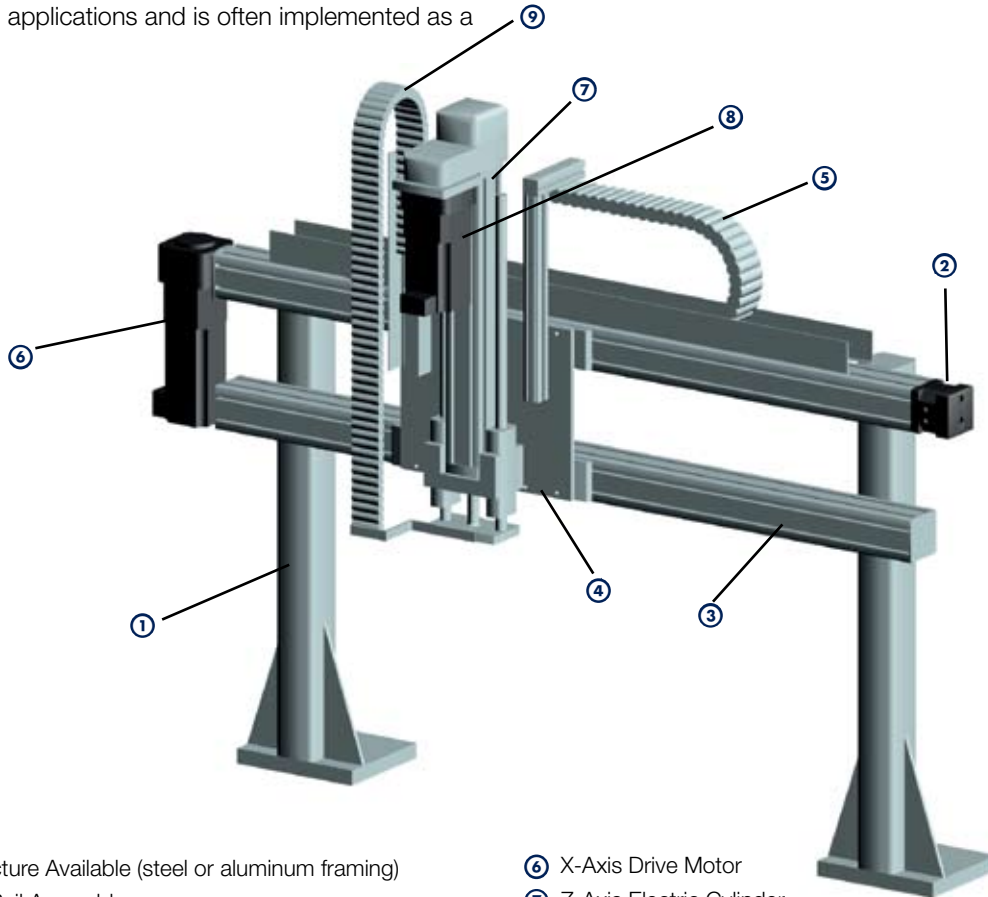
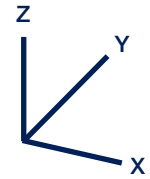

- ① Support Structure Available (steel or aluminum framing)
- ② X-Axis Drive Rail Assembly
- ③ X-Axis Idler Rail Assembly
- ④ Z-Axis Mounting Plate
- ⑤ X-Axis Cable Carrier
- ⑥ X-Axis Drive Motor
- ⑦ Z-Axis Electric Cylinder
- ⑧ Z-Axis Drive Motor
- ⑨ Z-Axis Cable Carrier

Series No.	Axis Model Number			Load (kg)	Travel			Velocity		
	X-Axis	Y-Axis	Z-Axis		X-Axis (meters)	Y-Axis (meters)	Z-Axis (meters)	X-Axis (m/sec.)	Y-Axis (m/sec.)	Z-Axis (m/sec.)
1	HLE60RB	—	ETB32	10	2.9	—	0.3	1.5	—	0.5
2	HLE60RB	—	ETB50	20	2.9	—	0.5	1.5	—	0.8
3	HLE60SR	—	ETB32	10	2.8	—	0.3	1.5	—	0.5
4	HLE60SR	—	ETB50	20	2.8	—	0.5	1.5	—	0.8
5	HPLA080	—	ETB50	35	5.4	—	0.5	2.0	—	0.8
6	HLE100RB	—	ETB50	40	6.0	—	0.5	2.0	—	0.8
7	HLE100RB	—	ETB80	50	6.0	—	1.0	2.0	—	0.5
8	HLE100SR	—	ETB50	40	6.0	—	0.5	2.0	—	0.5
9	HLE100SR	—	ETB80	50	6.0	—	1.0	2.0	—	0.5
10	HPLA120	—	ETB80	75	9.3	—	1.0	2.5	—	0.5
11	HPLA120	—	ETB100	100	9.3	—	1.0	2.5	—	1.0
12	HLE150RB	—	ETB80	75	7.9	—	1.0	2.5	—	0.5
13	HLE150RB	—	ETB100	100	7.9	—	1.0	2.5	—	1.0

Note: Loads, travels, and velocities shown are interdependent. Increased values are attainable.



Dimensions

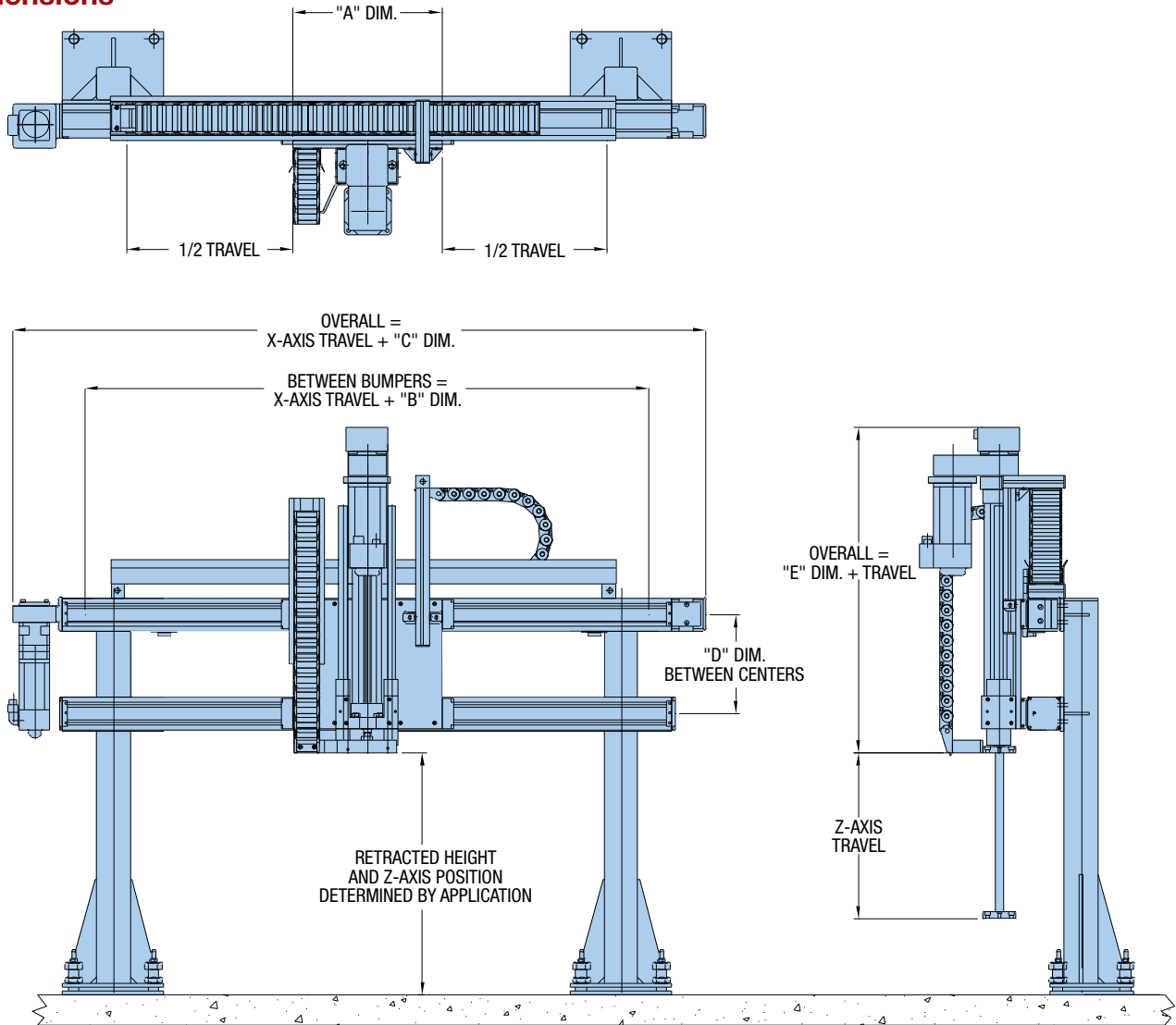

Belt Driven Tables

System Four XX' – Z (Electric Cylinder)					
Series No.	"A" Dim. mm (in.)	"B" Dim. mm (in.)	"C" Dim. mm (in.)	"D" Dim. mm (in.)	"E" Dim. mm (in.)
1	254.0 (10.00)	504.0 (19.84)	730.0 (28.74)	200.0 (7.87)	238.0 (9.37)
2	254.0 (10.00)	504.0 (19.84)	730.0 (28.74)	200.0 (7.87)	304.1 (11.97)
3	254.0 (10.00)	504.0 (19.84)	720.0 (28.35)	200.0 (7.87)	238.0 (9.37)
4	254.0 (10.00)	504.0 (19.84)	720.0 (28.35)	200.0 (7.87)	304.1 (11.97)
5	400.0 (15.75)	650.0 (25.59)	1012.0 (39.84)	250.0 (9.84)	304.1 (11.97)
6	450.0 (17.72)	700.0 (27.56)	1090.0 (42.91)	300.0 (11.81)	304.1 (11.97)
6	450.0 (17.72)	700.0 (27.56)	1090.0 (42.91)	300.0 (11.81)	321.9 (12.67)
7	450.0 (17.72)	700.0 (27.56)	1141.0 (44.92)	300.0 (11.81)	304.1 (11.97)
8	450.0 (17.72)	700.0 (27.56)	1141.0 (44.92)	300.0 (11.81)	321.9 (12.67)
10	500.0 (19.69)	750.0 (29.53)	1205.0 (47.44)	350.0 (13.78)	321.9 (12.67)
11	500.0 (19.69)	750.0 (29.53)	1205.0 (47.44)	350.0 (13.78)	494.0 (19.45)
12	500.0 (19.69)	750.0 (29.53)	1220.0 (48.03)	350.0 (13.78)	321.9 (12.67)
13	500.0 (19.69)	750.0 (29.53)	1220.0 (48.03)	350.0 (13.78)	494.0 (19.45)

System Five

System Five is an X-Z system utilizing the HZR belt driven unit for the vertical axis. The rigidity of the HZR permits higher vertical speed, greater X-axis acceleration, and larger moment loading than System Three.

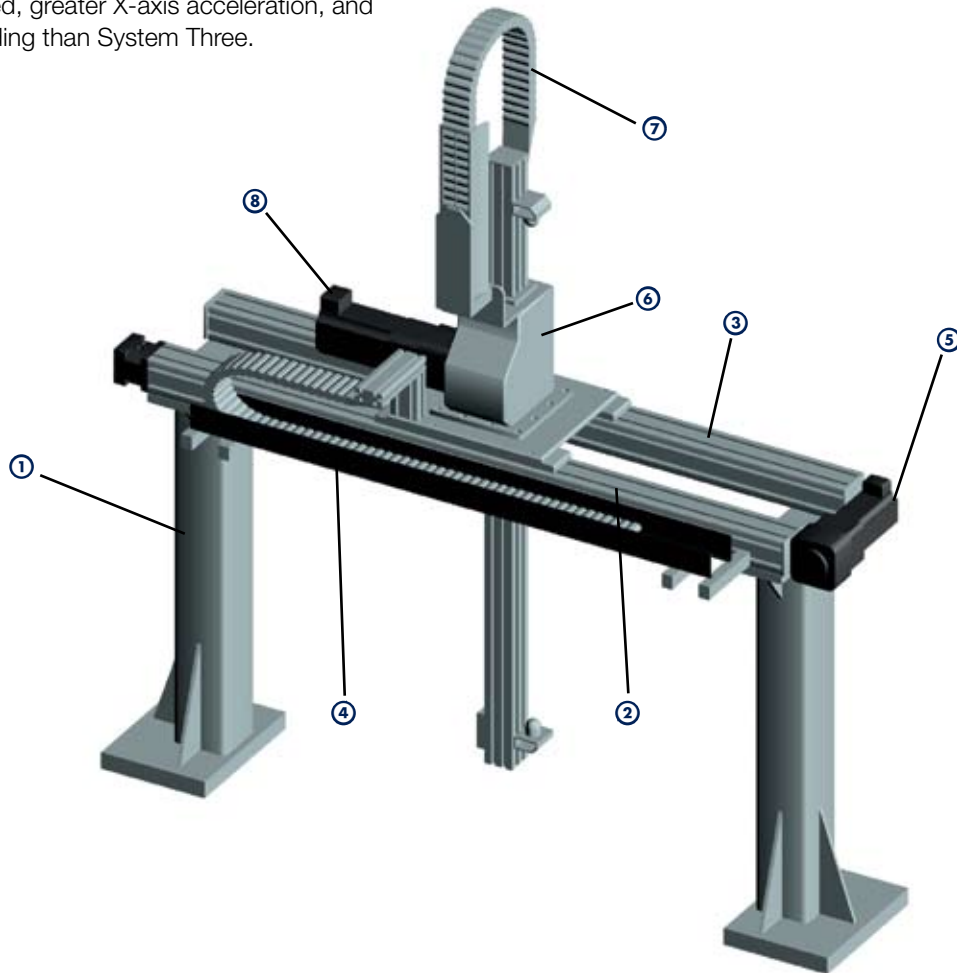
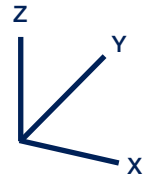

- ① Support Structure Available (steel or aluminum framing)
- ② X-Axis Drive Rail Assembly
- ③ X-Axis Idler Rail Assembly
- ④ X-Axis Cable Carrier
- ⑤ X-Axis Drive Motor
- ⑥ HZR Z-Axis with Flange Plate
- ⑦ Z-Axis Cable Carrier
- ⑧ Z-Axis Drive Motor

Series No.	Axis Model Number			Load (kg)	Travel			Velocity		
	X-Axis	Y-Axis	Z-Axis		X-Axis (meters)	Y-Axis (meters)	Z-Axis (meters)	X-Axis (m/sec.)	Y-Axis (m/sec.)	Z-Axis (m/sec.)
1	HLE100RB	—	HZR80	50	6.0	—	1.0	2.0	—	1.5
2	HLE100RB	—	HZR100	100	6.0	—	1.5	2.0	—	1.5
3	HLE100SR	—	HZR80	50	6.0	—	1.0	2.0	—	1.5
4	HLE100SR	—	HZR100	100	6.0	—	1.5	2.0	—	1.5
5	HPLA120	—	HZR80	50	9.3	—	1.0	2.5	—	1.5
6	HPLA120	—	HZR100	100	9.3	—	1.5	2.5	—	1.5
7	HLE150RB	—	HZR80	50	7.9	—	1.0	2.5	—	1.5
8	HLE150RB	—	HZR100	100	7.9	—	1.5	2.5	—	1.5

Note: Loads, travels, and velocities shown are interdependent. Increased values are attainable.





Dimensions

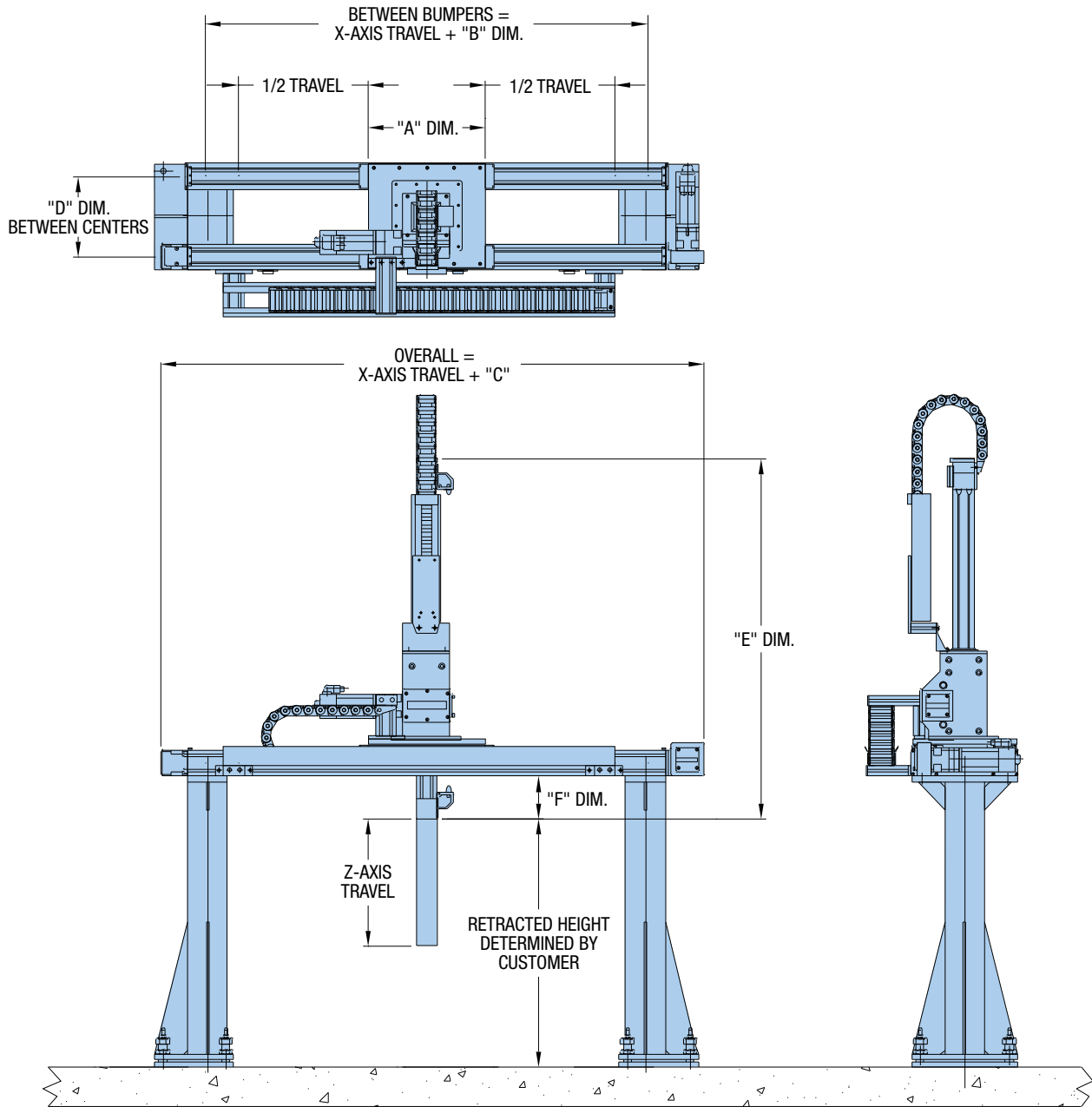

Belt Driven Tables

System Five XX' – Z (HZR)						
Series No.	"A" Dim mm (in.)	"B" Dim mm (in.)	"C" Dim mm (in.)	"D" Dim mm (in.)	"E" Dim mm (in.)	"F" Dim mm (in.)
1	450.0 (17.72)	700.0 (27.56)	1090.0 (42.91)	310.0 (12.21)	885.0 (34.84)	170.0 (6.69)
2	450.0 (17.72)	700.0 (27.56)	1090.0 (42.91)	360.0 (14.17)	1030.0 (40.55)	245.0 (9.65)
3	450.0 (17.72)	700.0 (27.56)	1141.0 (44.92)	310.0 (12.21)	885.0 (34.84)	170.0 (6.69)
4	450.0 (17.72)	700.0 (27.56)	1141.0 (44.92)	360.0 (14.17)	1030.0 (40.55)	245.0 (9.65)
5	500.0 (19.69)	750.0 (29.53)	1205.0 (47.44)	400.0 (15.75)	885.0 (34.84)	115.0 (4.53)
6	500.0 (19.69)	750.0 (29.53)	1205.0 (47.44)	400.0 (15.75)	1030.0 (40.55)	190.0 (7.48)
7	500.0 (19.69)	750.0 (29.53)	1220.0 (48.03)	400.0 (15.75)	885.0 (34.84)	115.0 (4.53)
8	500.0 (19.69)	750.0 (29.53)	1220.0 (48.03)	400.0 (15.75)	1030.0 (40.55)	190.0 (7.48)

System Six

System Six is a three-axes version of System Two. HPLA/HLE linear modules provide motion in the X and Y directions while a vertically mounted ET cylinder provides the third axis (Z) of motion. The ET cylinder provides high vertical thrust capacity at moderate speeds. With the Z-axis retracted, this system can transport moderate to heavy loads at high rates of speed over long travel distances.

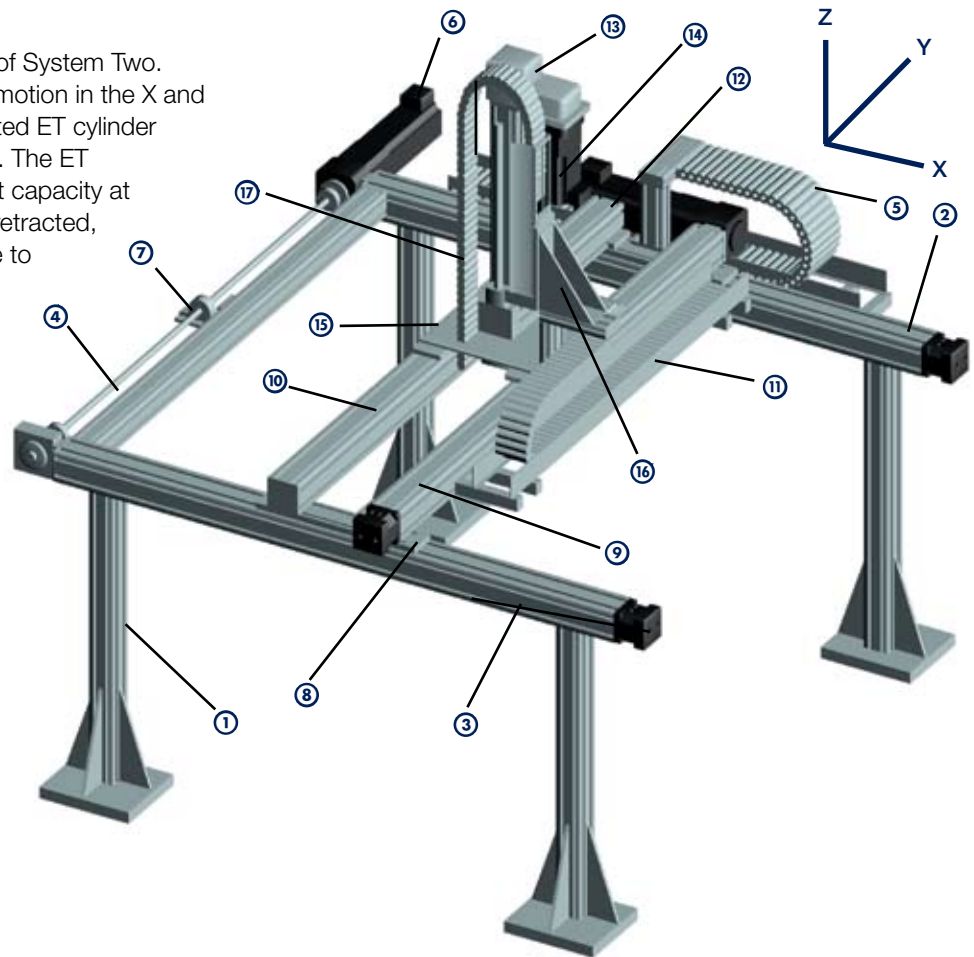

- ① Support Structure Available (steel or aluminum framing)
- ② X-Axis Drive Rail Assembly
- ③ X-Axis Driven Rail Assembly
- ④ X-Axis Link Shaft Assembly
- ⑤ X-Axis Cable Carrier
- ⑥ X-Axis Drive Motor
- ⑦ Pillow Block Bearing Support (Based on Application)
- ⑧ Clamping Profile
- ⑨ Y-Axis Drive Rail Assembly
- ⑩ Y-Axis Idler Rail Assembly
- ⑪ Y-Axis Cable Carrier
- ⑫ Y-Axis Drive Motor
- ⑬ Z-Axis ET Electric Cylinder
- ⑭ Z-Axis Drive Motor
- ⑮ Electric Cylinder Mounting Plate
- ⑯ Electric Cylinder Mounting Bracket
- ⑰ Z-Axis Cable Carrier

Series No.	Axis Model Number			Load (kg)	Travel			Velocity		
	X-Axis	Y-Axis	Z-Axis		X-Axis (meters)	Y-Axis (meters)	Z-Axis (meters)	X-Axis (m/sec.)	Y-Axis (m/sec.)	Z-Axis (m/sec.)
1	HLE60RB	HLE60RB	ETB32	10	2.9	1.0	0.3	1.0	1.5	0.5
2	HLE60RB	HLE60RB	ETB50	20	2.9	0.5	0.5	1.0	1.5	0.8
3	HLE60SR	HLE60SR	ETB32	10	2.8	1.0	0.3	1.0	1.5	0.5
4	HLE60SR	HLE60SR	ETB50	20	2.8	0.5	0.5	1.0	1.5	0.8
5	HPLA080	HPLA080	ETB50	45	5.4	1.5	0.5	2.0	2.0	0.8
6	HLE100RB	HLE100RB	ETB80	50	6.0	1.5	1.0	2.0	2.0	0.5
7	HLE100SR	HLE100SR	ETB80	50	6.0	1.4	1.0	2.0	2.0	0.5
8	HPLA120	HPLA120	ETB100	100	9.3	3.0	1.0	2.5	2.5	1.0
9	HLE150RB	HLE150RB	ETB100	100	7.9	3.0	1.0	2.5	2.5	1.0

Note: Loads, travels, and velocities shown are interdependent. Increased values are attainable.



Dimensions

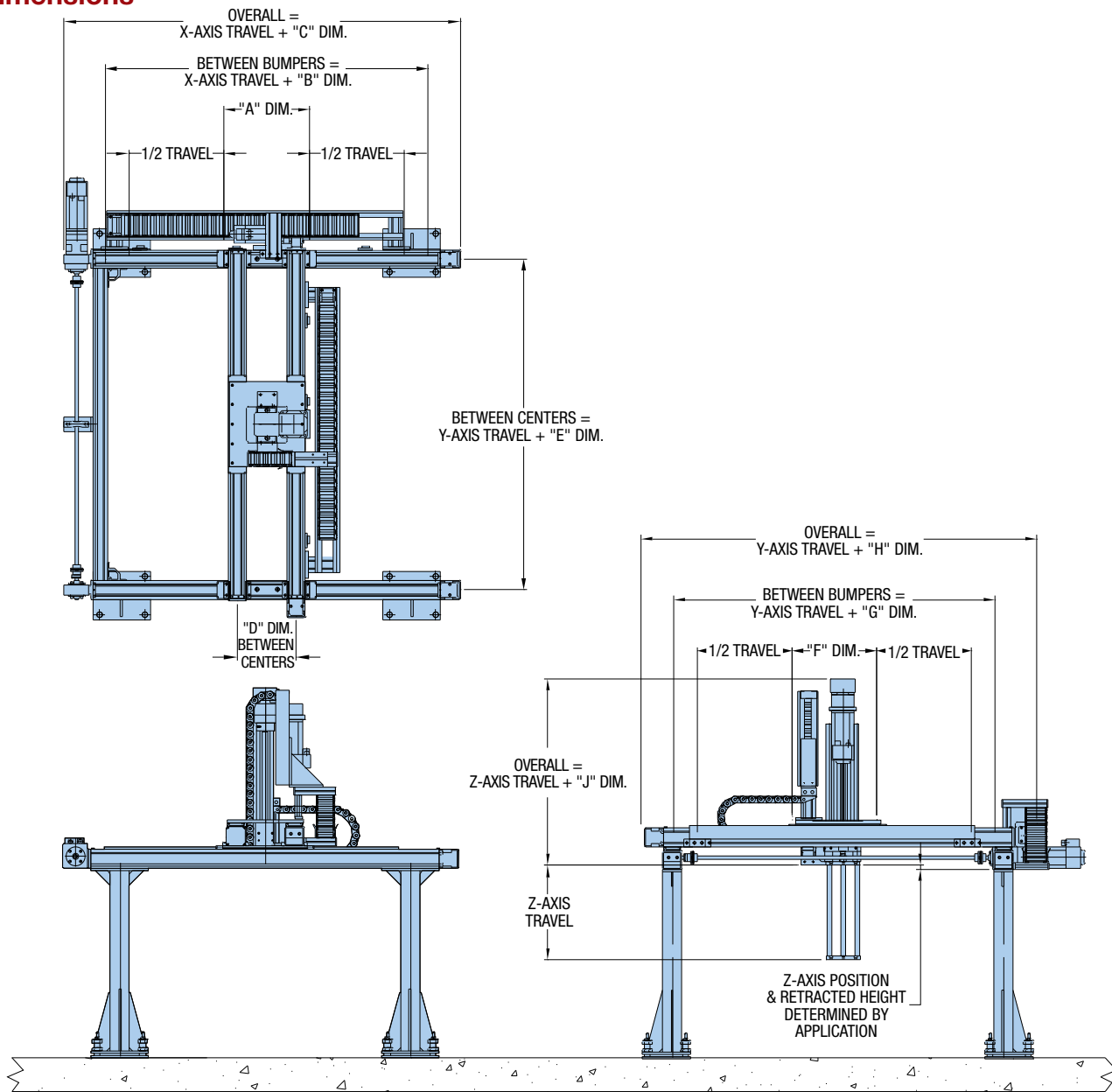

Belt Driven Tables

System Six XX' – YY' – Z (Electric Cylinder)									
Series No.	"A" Dim. mm (in.)	"B" Dim. mm (in.)	"C" Dim. mm (in.)	"D" Dim. mm (in.)	"E" Dim. mm (in.)	"F" Dim. mm (in.)	"G" Dim. mm (in.)	"H" Dim. mm (in.)	"J" Dim. mm (in.)
1	254.0 (10.00)	504.0 (19.84)	730.0 (28.74)	169.8 (6.69)	508.2 (20.01)	254.0 (10.00)	504.0 (19.84)	730.0 (28.74)	238.0 (9.37)
2	254.0 (10.00)	504.0 (19.84)	730.0 (28.74)	169.8 (6.69)	508.2 (20.01)	254.0 (10.00)	504.0 (19.84)	730.0 (28.74)	304.1 (11.97)
3	254.0 (10.00)	504.0 (19.84)	720.0 (28.35)	169.8 (6.69)	482.2 (19.98)	254.0 (10.00)	504.0 (19.84)	720.0 (28.35)	238.0 (9.37)
4	254.0 (10.00)	504.0 (19.84)	720.0 (28.35)	169.8 (6.69)	482.2 (19.98)	254.0 (10.00)	504.0 (19.84)	720.0 (28.35)	304.1 (11.97)
5	400.0 (15.75)	650.0 (25.59)	1012.0 (39.84)	280.0 (11.02)	680.0 (26.77)	400.0 (15.75)	650.0 (25.59)	1012.0 (39.84)	304.1 (11.97)
6	450.0 (17.72)	700.0 (27.56)	1090.0 (42.91)	310.0 (12.21)	738.0 (29.06)	450.0 (17.72)	700.0 (27.56)	1090.0 (42.91)	321.9 (12.67)
7	450.0 (17.72)	700.0 (27.56)	1141.0 (44.92)	310.0 (12.21)	755.0 (29.72)	450.0 (17.72)	700.0 (27.56)	1141.0 (44.92)	321.9 (12.67)
8	500.0 (19.69)	750.0 (29.53)	1205.0 (47.44)	330.0 (12.99)	760.0 (29.92)	500.0 (19.69)	750.0 (29.53)	1205.0 (47.44)	494.0 (19.45)
9	500.0 (19.69)	750.0 (29.53)	1220.0 (48.03)	300.0 (11.81)	762.0 (30.00)	500.0 (19.69)	750.0 (29.53)	1220.0 (48.03)	494.0 (19.45)

System Seven

System Seven is a three-axes system which utilizes the HZR unit for the vertical axis. As a result, this system can provide longer vertical travel, higher speed, and greater acceleration than System Six. The inherent rigidity of the HZR also contributes to superior system stiffness, stability, and ease of tuning. If the Z-axis is retracted during horizontal motion, System Seven can easily handle moderate to heavy loads. With the Z-axis fully extended it can handle light to moderate loads.

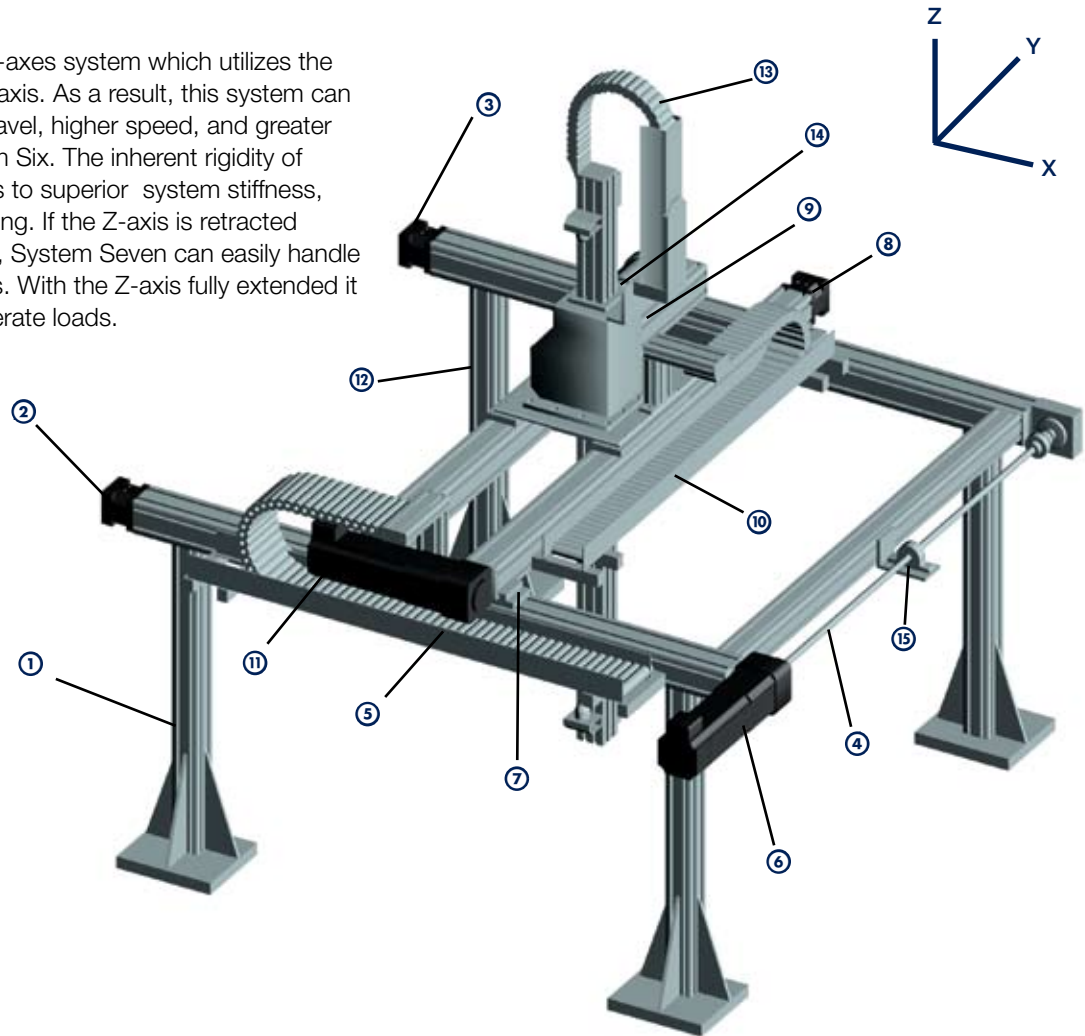

- ① Support Structure Available (steel or aluminum framing)
- ② X-Axis Drive Rail Assembly
- ③ X-Axis Driven Rail Assembly
- ④ X-Axis Link Shaft Assembly
- ⑤ X-Axis Cable Carrier
- ⑥ X-Axis Drive Motor
- ⑦ Clamping Profile
- ⑧ Y-Axis Drive Rail Assembly
- ⑨ Y-Axis Idler Rail Assembly
- ⑩ Y-Axis Cable Carrier
- ⑪ Y-Axis Drive Motor
- ⑫ HZR Z-Axis with Flange Plate
- ⑬ Z-Axis Cable Carrier
- ⑭ Z-Axis Drive Motor
- ⑮ Pillow Block Bearing & Support (Based on Application)

Series No.	Axis Model Number			Load (kg)	Travel			Velocity		
	X-Axis	Y-Axis	Z-Axis		X-Axis (meters)	Y-Axis (meters)	Z-Axis (meters)	X-Axis (m/sec.)	Y-Axis (m/sec.)	Z-Axis (m/sec.)
1	HLE100RB	HLE100RB	HZR80	50	6.0	2.0	1.0	2.0	2.0	1.5
2	HLE100RB	HLE100RB	HZR100	100	6.0	1.3	1.5	2.0	2.0	1.5
3	HLE100SR	HLE100SR	HZR80	50	6.0	2.0	1.0	2.0	2.0	1.5
4	HLE100SR	HLE100SR	HZR100	100	6.0	1.3	1.5	2.0	2.0	1.5
5	HPLA120	HPLA120	HZR80	50	9.3	4.0	1.0	2.5	2.5	1.5
6	HPLA120	HPLA120	HZR100	100	9.3	3.3	1.5	2.5	2.5	1.5
7	HLE150RB	HLE150RB	HZR80	50	7.9	4.0	1.0	2.5	2.5	1.5
8	HLE150RB	HLE150RB	HZR100	100	7.9	3.3	1.5	2.5	2.5	1.5

Note: Loads, travels, and velocities shown are interdependent. Increased values are attainable.





Dimensions

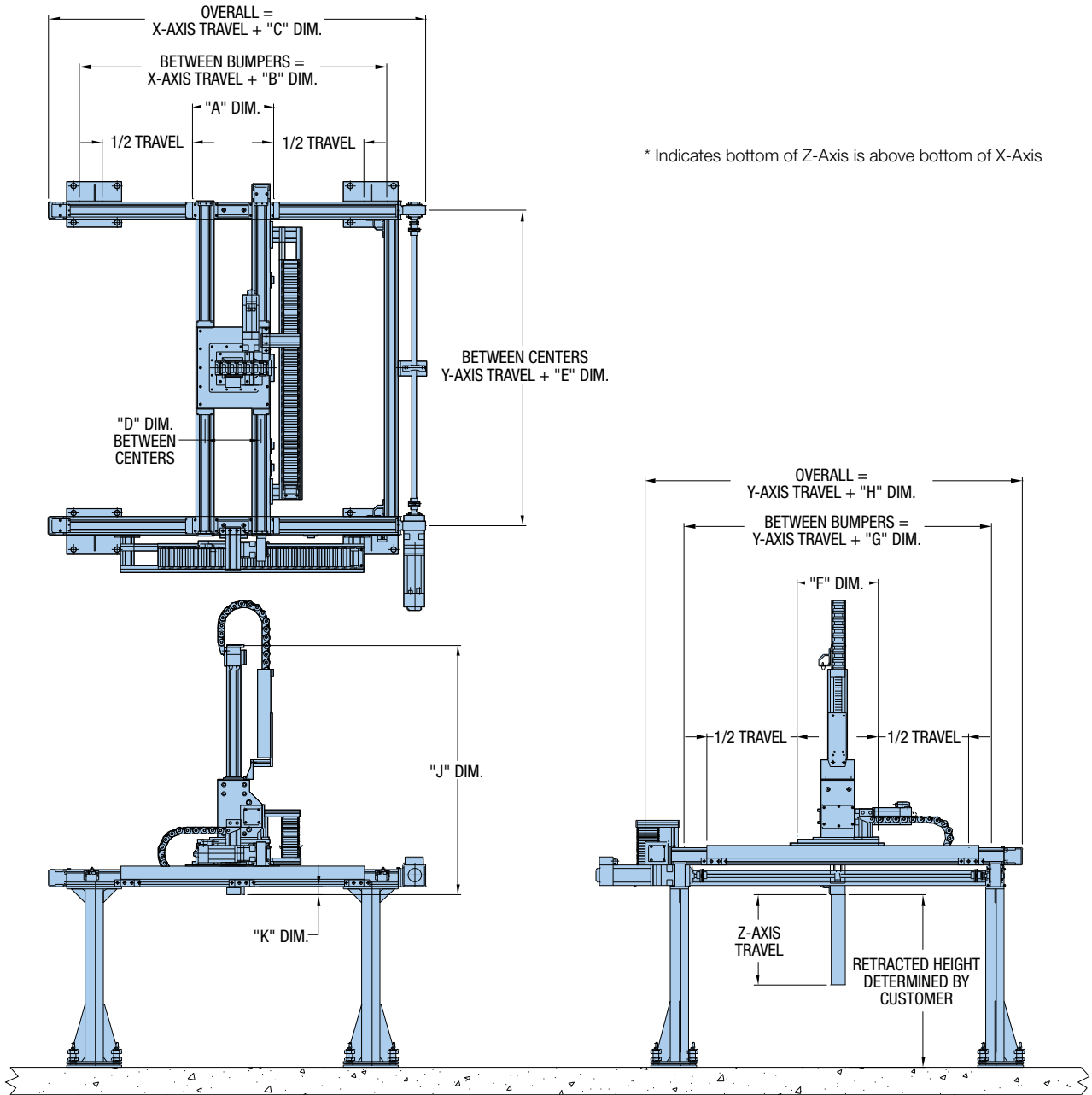

Belt Driven Tables

System Seven XX' – YY' – HZR										
Series No.	"A" Dim. mm (in.)	"B" Dim. mm (in.)	"C" Dim. mm (in.)	"D" Dim. mm (in.)	"E" Dim. mm (in.)	"F" Dim. mm (in.)	"G" Dim. mm (in.)	"H" Dim. mm (in.)	"J" Dim. mm (in.)	"K" Dim. mm (in.)
1	450 (17.72)	700 (27.56)	1090 (42.91)	310 (12.21)	738 (29.06)	450 (17.72)	700 (27.56)	1090 (42.91)	885 (34.84)	50 (1.97)
2	450 (17.72)	700 (27.56)	1090 (42.91)	310 (12.21)	738 (29.06)	450 (17.72)	700 (27.56)	1090 (42.91)	1030 (40.55)	125 (4.92)
3	450 (17.72)	700 (27.56)	1141 (44.92)	310 (12.21)	755 (29.72)	450 (17.72)	700 (27.56)	1141 (44.92)	885 (34.84)	50 (1.97)
4	450 (17.72)	700 (27.56)	1141 (44.92)	310 (12.21)	755 (29.72)	450 (17.72)	700 (27.56)	1141 (44.92)	1030 (40.55)	125 (4.92)
5	500 (19.69)	750 (29.53)	1205 (47.44)	330 (12.99)	760 (29.92)	500 (19.69)	750 (29.53)	1205 (47.44)	885 (34.84)	60 (2.36)
6	500 (19.69)	750 (29.53)	1205 (47.44)	330 (12.99)	760 (29.92)	500 (19.69)	750 (29.53)	1205 (47.44)	1030 (40.55)	15 (0.59)
7	550 (21.65)	800 (31.50)	1270 (50.00)	350 (13.78)	762 (30.00)	500 (19.69)	750 (29.53)	1220 (48.03)	885 (34.84)	60 (2.36)
8	600 (23.62)	850 (33.47)	1320 (51.97)	400 (15.75)	762 (30.00)	500 (19.69)	750 (29.53)	1220 (48.03)	1030 (40.55)	15 (0.59)

Gantry Systems Capabilities & Accessories

Parker's gantry systems provide cost-effective, easy to integrate solutions that satisfy the vast majority of automation requirements. In addition to these standard gantry systems, Parker offers products with additional capabilities to fulfill the needs of special applications. Our engineering skill and manufacturing expertise have integrated these products into custom-tailored gantry solutions which have successfully addressed the most unique and exacting requirements of machine builders and integrators around the world.

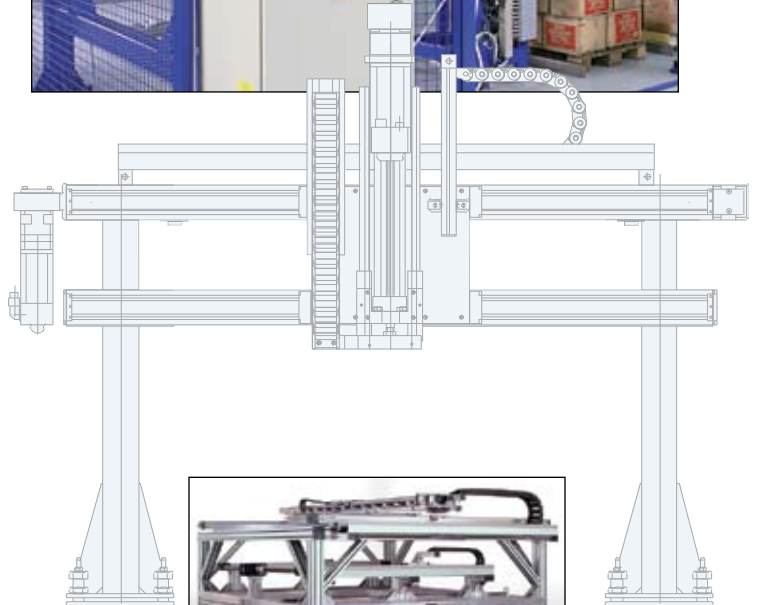

Support Structures

Parker can include the support structure and machine guarding as part of your complete system solution. Parker's ParFrame™ extruded aluminum structures are suited for light to medium duty requirements. High strength steel supports are offered for applications involving greater loads and forces.

Aluminum Structures

- Lightweight aluminum extrusions
- Economical modular construction
- Standard metric sizes – compatible with linear drive units

Steel Support Structures

- Heavy duty support
- High system stiffness
- Ideal for higher overhead gantries
- Engineered and fabricated to customer specifications

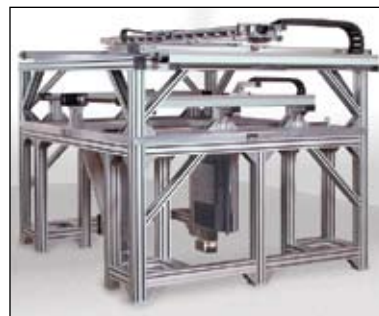

**Gantry Robot CD available at
www.parkermotion.com**

- Sizing
- Software
- CAD Files (Parametric Tools)
- Product Manuals
- Photos/Applications Library
- Movie Gallery



Motors, Drives, and Controls (Electrical Subsystems)

A high speed multi-axis Gantry Robot requires a complete electromechanical solution where the machine Interface, Control and Motor/Drive functions are seamlessly integrated with the mechanical elements. Parker's wide range of electrical products and subsystems enable Gantry Robots to be supplied to the customer at the level of integration most suitable for his need. A basic mechanical unit; a unit including drives and motors; or a full blown electromechanical system ready to run or link to a PLC, whatever is needed for your automation requirement, Parker has the best solution.

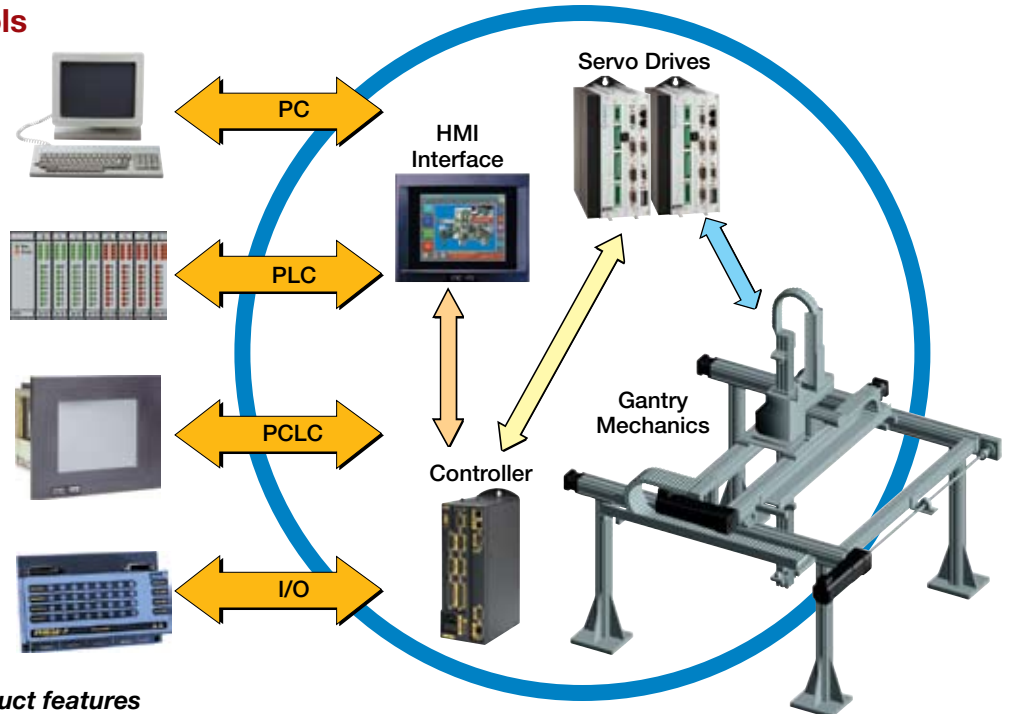

For complete details on drive product features and specifications, please refer to the "Drives & Controllers" section of this catalog.

Open Architecture Bundled HMI Solution

Parker's CTC division bundles a tightly integrated Human Machine Interface and PC-based Control solution with an open PC hardware platform. A single source that provides affordable integration of factory-hardened PC workstations with the industry's leading HMI and control software. For additional information on Human to Machine Interface and Integrated Machine Control go to www.ctcusa.com



Compax 3 Servo Drives

With its high-performance and modular design, the Compax3 family of industrial servo drives and drive/controllers offers a new level of servo performance and flexibility. The modular structure of the Compax3 family allows options such as intelligent motion controllers, fieldbus interfaces and industry standard motor feedback. In addition, numerous expansion options can be added to the standard product in order to optimize the capabilities required for today's demanding servo applications.



Belt Driven Tables

ACR9000 Series Stand Alone Controller

The ACR9000 series of motion controllers combine high performance and functionality into a standalone unit.

In addition to standard motion control functions, the ACR9000 offers many additional features including triggered floating point electronic gearing, triggered segmented electronic CAM, on-the-fly position and velocity matching, interruptible moves, analog or digital feedback for position or velocity loops, dual-encoder feedback, data teach and learn functions, plus 3-D arcs and splines. The ACR software tools provides further functionality and features.



Brushless Servo Motors

Parker's Compumotor division offers servo drives which feature advanced technologies in motor design: Slotless Stator design, and the Bridged Stator design. These designs provide significant performance advantages to the user. The slotless design eliminates detent torque in the motor, permitting superior performance where smooth, low speed operation is required. The bridged stator design results in very high torque-to-inertia ratios, providing a performance advantage where high accelerations are needed.

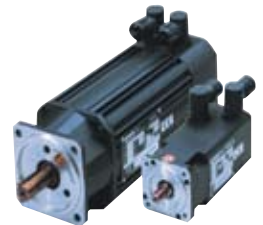

Limit and Home Sensors

“End of Travel” Limit Sensors are offered to assure safe operation of the unit by restricting travel to within allowable parameters. This range is dependent upon the load, velocity and acceleration factors determined by the application.

A “Home” Sensor can be positioned to establish a “Machine Start-up” location within the range of travel. Either mechanical or electrical proximity switches can be selected. Limit sensors can be easily positioned along the length of travel to further reduce the allowable operating envelope.

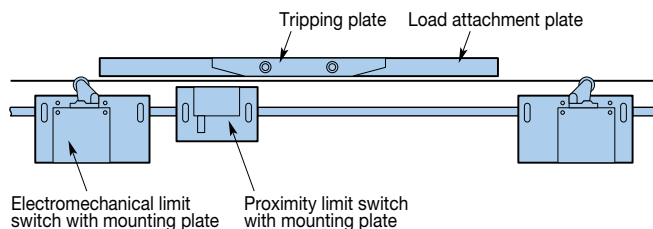

Mechanical Switches

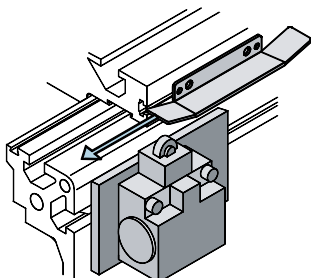

Product
HPLA (all models):
HLE100-RB, HLE100-SR,
HLE150-RB, HLE150-Z

Part Number
002-2442-01
510-900500
510-900505

Mechanical switches are triggered by the standard tripping plate. These switches provide one NC and one NO contact per switch.

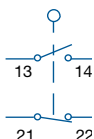

Contact Rating	200 V, 6 A
Mechanical Lifespan	1,000,000 operations
Operating Temperature	-25° C to 40° C (-13° F to 104° F)
Protection Class	IP65
Terminal Capacity	0, 25 mm ² (24 AWG)

Electrical Proximity Switches

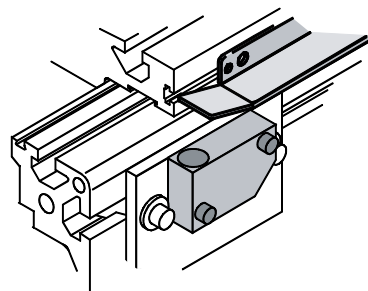

4-wire NPN switch with mounting hardware

Product	Part Number
HPLA (all models):	002-2440-03
HLE60-RB, HLE60-SR	002-1892-01
HLE100-RB, HLE100-SR	510-900010
HLE150-RB, HLE150-Z	510-900030

4-wire PNP switch with mounting hardware

Product	Part Number
HPLA (all models):	002-2440-01
HLE60-RB, HLE60-SR	002-1892-02
HLE100-RB, HLE100-SR	510-900020
HLE150-RB, HLE150-Z	510-900040

Inductive proximity switches are triggered by a standard tripping plate mounted to the side of the carriage. Available in both NPN and PNP 4-wire DC complementary outputs, the switches can be wired either NO or NC operation.

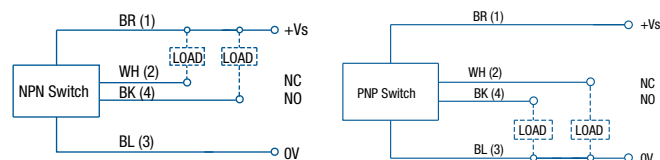

Sensing Distance	4 mm ± 10%
Voltage Supply	10-30 VDC
Switching Capacity	200 mA
Switching Response	2000 Hz
Current Consumption	<200 mA
Voltage Drop	<3 V
Protection Class	IP67
Operating Temperature	-25° C to 70° C (-13° F to 158° F)
Lead Termination	5 meter (200 in)
Reverse Polarity Protection	Yes
Short Circuit Protection	Yes

Cable Carriers

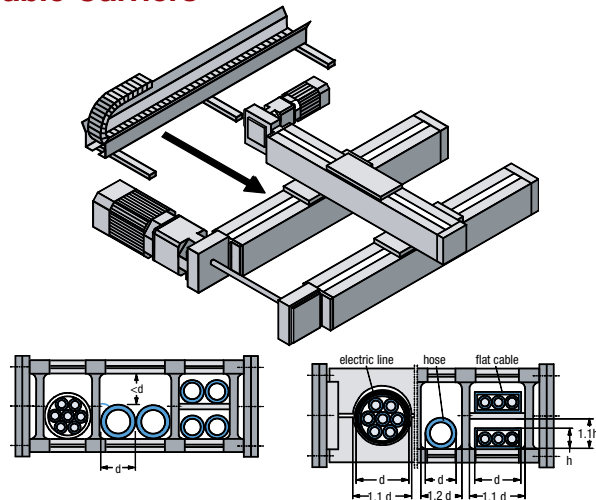

Typical Cross Sections

A cable carrier assembly is normally needed to transport cables to the carriage or custom payload. A complete cable carrier assembly includes the carrier, trough, end brackets, and mounting hardware. The cable carrier should be specifically matched to the linear actuator and other application requirements. Because of the extreme amount of cable flexing associated with high speed cable management, Parker uses only long life high-flex cables with its gantry systems. We recommend that all electric cables be approved for high speed cable carrier usage and that manufacturer's guidelines for bend radii are followed.

Cable Carrier Guidelines:

Hose lines should be highly flexible and should only extend slightly under pressure. Weight should be distributed across the cable track as evenly as possible. Cables must not be twisted when routed in the cable carrier and should be routed next to one another with approximately 10% additional space.

Avoid laying several lines on top of each other and laying lines of different diameters directly next to one another. If multiple layers must be used, dividers should be inserted between each layer – should such circumstances arise, please contact a Parker application engineer. If there is no alternative to routing several lines beside each other without subdivisions, the clearance height within the carrier must be less than line diameter. This is the only way of preventing the cables from twisting. The supply cables must be able to move freely in the cable carrier – they must never be fastened or bundled together. Separating strips must always be inserted between flat cables routed in multiple layers.

Due to diversity of the requirements associated with high speed cable management systems, it is recommended that you contact your Parker applications engineer.

Cable Carrier Junction Box

For systems utilizing cable carriers, Parker recommends and is able to provide junction boxes and high-flex cables for limit switch assemblies. The junction box and cable consolidate the wiring through the cable carriers and provide a "clean" solution for routing limit switch wires to the motion controller.

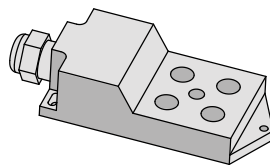

Toe Clamps

The toe clamps are used to rapidly install and fasten various combinations of linear actuators to each other; to a ParFrame™ structure; or to a mounting surface. Two clamps are required to fasten an HLE, HPLA, or HLEZ to a load attachment plate. The table at right shows the profiles for the various axis combinations.

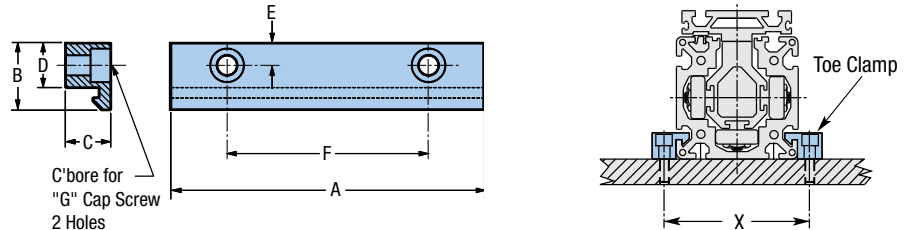
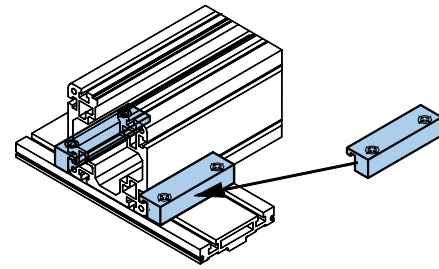

Used With	Part Number	Dimensions							
		A	B	C	D	E	F	G	X
HLE60-RB, HLE60-SR	000-7752-01	54	18	10	12	6	43	M5	70
HPLA080	500-000931	76	27	17	20	10	48	M5	100
HPLA080	500-000932	90	27	17	20	10	60	M8	100
HPLA080	500-000930	110	27	17	20	10	70	M8	100
HLE100-RB, HLE100-SR	500-000901	90	30	20	20	10	60	M6	120
HPLA120	500-000925	110	37.5	26	25	12.5	70	M8	145
HPLA180	500-000920	170	45	36	30	15	110	M10	210
HLE150-RB, HLE150-Z	500-000902	140	40	30	25	12	90	M8	176

Splice Plates

Splice Plates enable travels to be extended significantly beyond the standard range which is limited by extrusion length. Design concepts and factory installation expertise combine to produce perfectly spliced units which are easily recreated on site. The splice plate connection is only recommended for units with the carriage in the top or the bottom position.

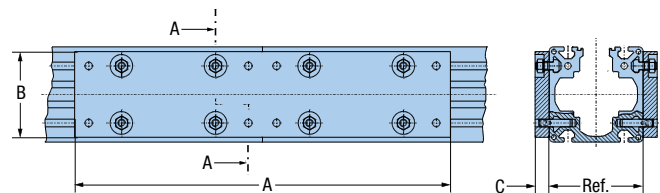
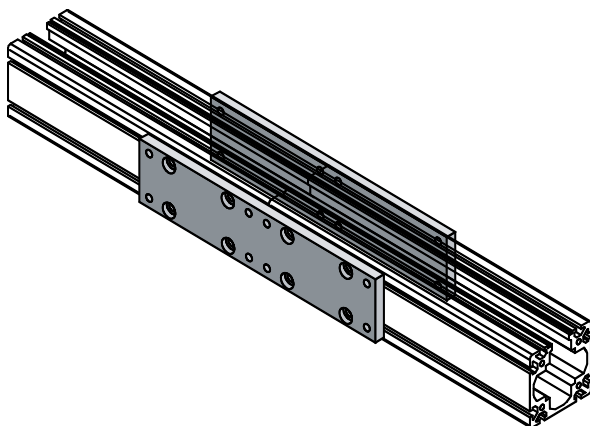

Model/Size	Dimensions			
	A	B	C	Ref.
HPLA080	300	70	15	80
HLE100-RB, HLE100-SR	400	90	15	100
HPLA120	400	110	15	120
HLE150-RB, HLE150-Z	500	130	15	150
HPLA180	500	165	20	180

T-Nuts and T-Bolts

The T-nuts and bolts are used to fasten any element into the T-slots of the profile and to the upper side of the flange plate.

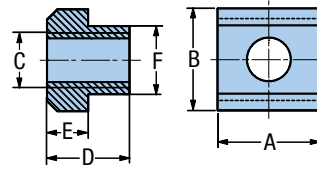

T-Nuts

Standard Part Number	Corrosion Resistant Part Number	Used With	Dimensions (mm)					
			A	B	C	D	E	F
100-2353-01	—	HLE60-RB, HLE60-SR	11	9	M5	3	—	—
131-700102	135-725390	HPLA080	10	10	M5	8	4	5.6
131-700147	--	HPLA080	20	10	M5	8	4	5.6
131-700103	135-725400	HLE100-RB, HLE100-SR	13	13	M6	10	6	—
131-700135	—	HPLA120, HLE150-RB, HLE150-Z	15	15	M6	12	6	10
131-700104	135-725402	HPLA120, HLE150-RB, HLE150-Z	15	15	M8	12	6	10
131-700141	135-725406	HPLA120, HLE150-RB, HLE150-Z	30	15	M8	12	6	10
131-700112	135-725401	HPLA180	18	18	M6	14	7	12
131-700111	135-725420	HPLA180	35	18	M10	14	7	12

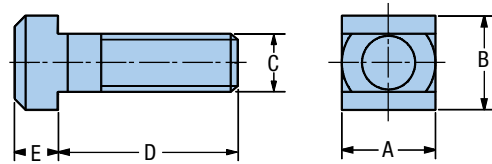

T-Bolts

Standard Part Number	Corrosion Resistant Part Number	Used With	Dimensions (mm)				
			A	B	C	D	E
131-700030	135-725430	HPLA080	10	10	M6	15	4
131-700031	—	HPLA080	10	10	M6	25	4
131-700032	—	HPLA080	10	10	M6	30	4
131-700001	—	HLE100-RB, HLE100-SR	13	13	M8	25	6
131-700002	135-725450	HLE100-RB, HLE100-SR	13	13	M8	32	6
131-700007	135-725459	HPLA120	15	15	M10	25	6
131-700008	135-725460	HPLA120, HLE150-RB, HLE150-Z	15	15	M10	32	6
131-700009	135-725465	HLE150-RB, HLE150-Z	15	15	M10	40	6
131-700016	135-725482	HPLA180	18	18	M12	25	7
131-700015	135-725480	HPLA180	18	18	M12	50	7

External Bumpers

External bumpers serve as adjustable hard stops. They are fitted to the grooves in the housing profile and are often utilized for restricting total travel.

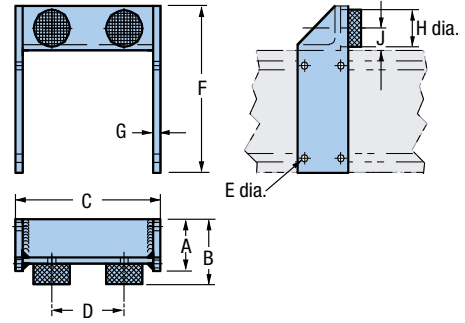
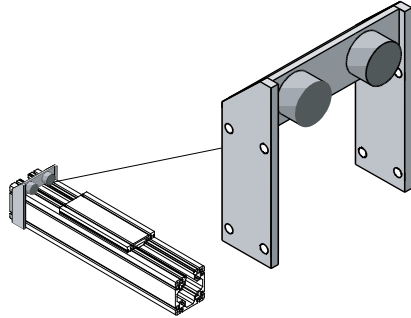

HPLA Series

Part Number	Used With	Dimensions (mm)								
		A	B	C	D	E	F	G	H	J
510-006497	HPLA080	30	45	90	56	5.5	91	5	15	11
510-007497	HPLA120	50	60	140	74	9	150	10	30	17
510-008497	HPLA150	70	88	200	100	11	225	10	50	30

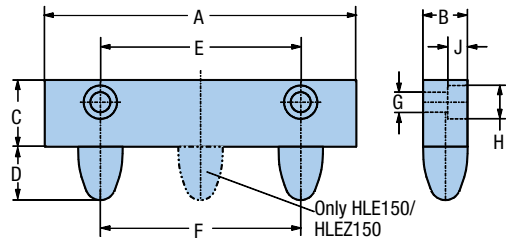
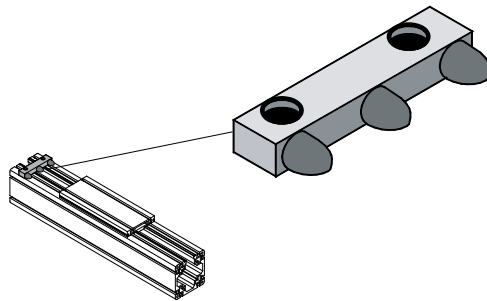

HLE Series

Part Number	Used With	Dimensions (mm)								
		A	B	C	D	E	F	G	H	J
510-300004	HLE100-RB, HLE100-SR	90	20	30	24	60	40	6.6	11	6.8
510-300005	HLE150-RB, HLE150-Z	140	20	30	24	90	90	6.6	11	9.0

ERV and ER Series Rodless Actuators

www.parker.com/em/erv
www.parker.com/em/er

Parker's ERV Series rodless actuator is designed in an affordable package that includes an extruded base and an external carriage containing outboard roller bearings for high load capacity.

- High-strength extruded body
- External bearing carriage for high loads
- Economical design for high-load and high-speed applications

The ER Series rodless actuator features an internal bearing carriage and the option of a belt or screw drive.

- Modular design with either belt or screw drive
- Internal bearing carriage with strip seal

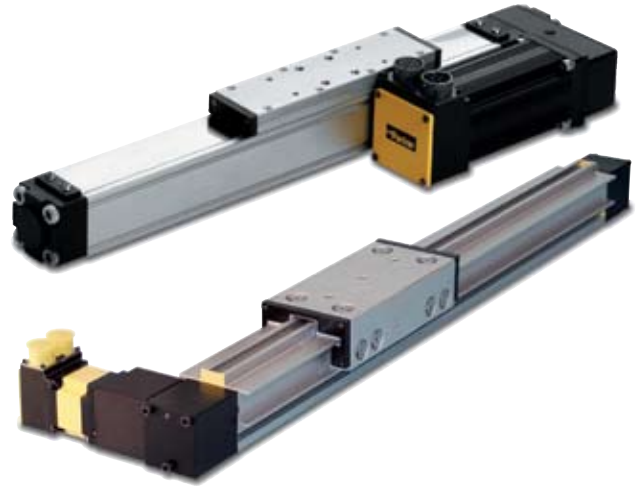

Series	ER32	ER50	ERV5	ERV8
Max load:				
Roller bearing N (lbf)	222 (50)	445 (100)	1,126 (253)	2,112 (474)
Max load:				
Square rail N (lbf)	1,112 (250)	2,224 (500)	—	—
Extended carriage N (lbf)	—	—	1,915 (430)	3,590 (807)
Max velocity:				
Belt m/sec (in./sec)*	3.5 (140)	—	5.0 (200)	5.0 (200)
Ball screw m/sec (in/sec)*	0.4 (15.6)	1.5 (60)	—	—
Acme screw m/sec (in/sec)*	0.8 (31.2)	0.64 (25)	—	—
Rated acceleration (g)*	9.8 (386)	9.8 (386)	9.8 (386)	9.8 (386)
Max travel m (in)**	1 (39.2)	1.5 (59.0)	6 (238)	6 (237)
Bi-directional repeatability				
Screw (mm)	±0.025/±0.152 (±0.001/±0.006)		—	
Belt (mm)	±0.102/±0.203 (±0.004/±0.008)		±0.1/±0.2 (±0.004/±0.008)	

*Application dependant, consult catalog for specifications.
 **Single piece Extrusion, Longer strokes available with spliced units.

Belt Driven Tables

LCB Series Compact Rodless Actuators

www.parker.com/em/lcb

The LCB Series of linear actuators incorporates a low-friction, dry running, sliding bearing carriage that provides long and reliable travel life even at 100% duty cycle. The low mass of the carriage and steel-reinforced timing belt design allows for very high accelerations and velocity. Combined with Parker motors and controls, the LCB offers a fully programmable, high-performance solution at a great value.



Series	LCB040	LCB060
Max Load, N (lbf)	60 (13)	295 (66)
Max Velocity, m/sec (in/sec)	8.0 (315)	8.0 (315)
Rated acceleration (g's)*	20 (787)	20 (787)
Max travel m (in)*	2.0 (78)	5.5 (216)
Bi-directional repeatability (mm)	±0.2 (±0.008)	±0.2 (±0.008)

*Application dependant, consult catalog for specifications

LR Series Linear Roller Systems

www.parker.com/em/lr

Linear Roller Series products from Parker IPS provide a high level load-bearing strength, and flexibility in a modular, low-cost package. These products utilize standard components and can adapt to a wide range of applications.

- Carriage loads to 2,597 lb
- Custom carriage options
- Speeds up to 5 m/sec
- Easy mounting to AC motors
- Stroke lengths over 6 m
- Instant motor/gearbox approval



Series	LR 6	LR 14	LR 14HD	LR 25
Maximum carriage load N (lbf)	649 (146)	2,669 (600)	3,350 (753)	11,552 (2,597)
Pulley diameter (mm): reversing unit 40	47.75	47.75	47.75	47.75
Pulley diameter (mm): reversing unit 80	89.12	89.12	89.12	89.12
Pulley lead (mm/rev): reversing unit 40	150	150	150	150
Pulley lead (mm/rev): reversing Unit 80	280	280	280	280
Maximum travel without splice (mm)*	5900	5850	5840	5680
Minimum travel (mm)	300	250	240	80
Maximum drive torque (Nm): reversing unit 40	20	20	20	20
Maximum drive torque (Nm): reversing unit 80	37	37	37	37
Maximum belt traction (lb/belt)	575	575	575	575
Maximum number of belts	1	4	4	4
Maximum speed (m/s)	5	5	5	5
Maximum acceleration at no load (m/s²)	10	10	10	10
Repeatability (mm)	±0.2	±0.2	±0.2	±0.2

*Consult factory for long travel lengths

ET Series Electric Cylinders

www.parker.com/em/et

The ET Series electric cylinders are engineered to provide long life and high thrust capacity in a compact cylinder package. Its robust design ensures durability in the most demanding applications.

- Ball or acme screw drive
- Angular contact thrust bearings for long life
- Stainless steel thrust tube
- Anti-rotate rod guide bearing
- IP65 option available
- Cleanroom preparation available
- 3-D drawings available online



Series	ET32	ET50	ET80	ET100	ET125
Max thrust N (lbf)	600 (135)	3,200 (720)	7,120 (1,600)	23,500 (5,300)	44,500 (10,000)
Max velocity					
 Ballscrew, m/sec (in/sec)*	1.3 (50)	1.5 (60)	1.3 (50)	1.3 (50)	1.5 (60)
 Acme screw, m/sec (in/sec)*	0.8 (31.2)	0.64 (25)	0.8 (31.2)	0.4 (15.6)	—
Rated acceleration (g)*	9.8 (386)	9.8 (386)	9.8 (386)	9.8 (386)	9.8 (386)
Max travel (m)	1000 (39.4)	1500 (59)	1500 (59)	1500 (59)	1500 (59)
Bidirectional repeatability (mm)	±0.025/±0.152 (±0.001/±0.006)				

*Application dependant, consult catalog for specifications

HTR Telescopic Vertical Module

Visit our website for a pdf download

The HTR is a telescopic belt driven module designed to provide a long vertical travel where ceiling height or other overhead restrictions must be considered. Two “tube sections” connected with belts and pulleys generate smooth telescopic extension. A unique guiding mechanism provides overall stability.

- Ideal for low ceiling height
- Modular compatibility with other HLE units
- Capable of five meters per second velocity
- Compact platform and attractive appearance

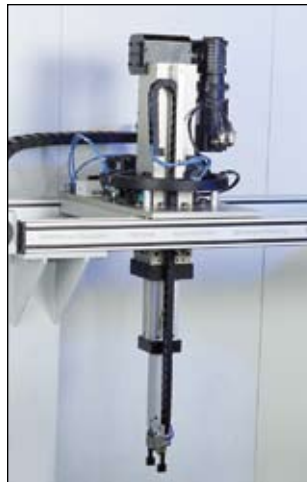

HDM Rotary Modules

The HDM35 is a compact, easily integrated mechanism that adds rotary motion to the vertical axis of a gantry robot. It is designed to mount to the HZR80 and HZR100 vertical units. The HDM35 utilizes a gearbox and motor combination to rotate a vertical drive shaft that passes through the center of the extruded profile.

- 700 degrees of continuous rotation
- Easily integrated
- 360 degrees per second rotation

The HDM409 is a heavy duty rotary mechanism for use with the HZR100 or HTR80 vertical units. The HDM409 supports and rotates the entire Z-axis, thus permitting the full load carrying capability of the vertical axis to be utilized.

- 350 degrees of rotation
- HTR80 and HZR100 compatible
- Heavy duty gear drive mechanism
- Larger payload capability than the HDM35

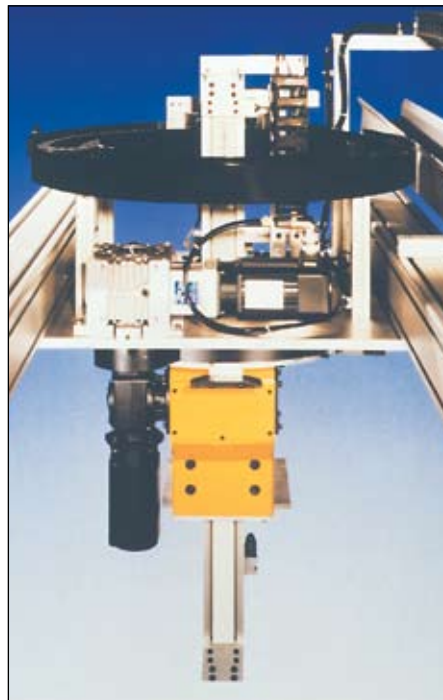



Drives & Controllers for Daedal positioning tables

Parker electromechanical automation products are built using industry standard interfaces and market-leading features that combine great value and performance. For a cost-effective and efficient solution, Parker offers bundled or kitted systems. We can combine motors, gearheads, and positioning systems to deliver a configured subsystem ready for installation. Parker configuration and setup software accommodates the rest of the product line, making start-up a snap. Combining this with our custom product modification capabilities gives the machine builder an economical custom-fit solution, with reduced engineering effort, straightforward integration, and modular compatibility.

Contents

282-283	Planetary Gearheads
284-285	Rotary Servo Motors
286	Frameless Motors
287-289	Servo Drives and Controller Drives
290	Stepper Drives and Controller Drives
291	ACR Motion Controllers
292	Real-Time Ethernet Motion Control
293-295	Human Machine Interface

Planetary Gearheads

PS/PX/RS/RX Series Stealth Gen II Precision Gearheads

www.parker.com/em/pgearheads



The Stealth Gen II Helical Planetary Gearheads incorporate design enhancements to provide superior performance for the most demanding high performance applications.

Stealth Gen II incorporates dual angular contact bearings providing higher radial load capacities while maintaining high input speeds. Design enhancements also include full compliment needle bearings allowing for increased service life and extended warranties. Internal design changes and optimized gearing geometries allow for one fill level for any orientation, resulting in shortened part number designation and simplified order placement.

Universal mounting kits provide common mounting kits across multiple product lines to promote quicker deliveries and ease of mounting to any servo motor.

Applications that require either high precision (PS/RS Series Gearheads), or mid-range precision (PX/RX Series Gearheads) or lower precision (PV Series Gearheads), utilize the same mounting kit part numbers within the same frame size.

- Higher radial load capacity: Widely spaced angular contact output bearings
- Increased service life: Full compliment needle planet bearings
- Universal mounting kits: Quicker deliveries and easier mounting
- High torque and low backlash: Helical planetary gearing
- High stiffness: Integral ring gear and rigid sun gear
- Higher gear wear resistance: Plasma Nitriding heat treating

Product Series	Gear Geometry	Configuration	Frame Sizes (mm)	Continuous Torque (Nm)	Radial Load (N)	Service Life (hrs)	Backlash
PS	Helical Planetary	In-Line	60 to 220	40 to 1800	>8400	20,000	<3
PX	Helical Planetary	In-Line	60 to 142 (NEMA 23 to 56)	30 to 280	>4050	20,000	<6
RS	Helical Planetary/ Spiral Bevel	Right Angle	60 to 220	35 to 1800	>8400	20,000	<4
RX	Helical Planetary/ Spur Bevel	Right Angle	60 to 142 (NEMA 23 to 56)	25 to 130	>4500	20,000	<12

PV Series Precision Gearheads

www.parker.com/em/pgearheads



The PV Series gearhead combines power and versatility in an economical package. It comes in a wide range of options including dimensional output face crossovers to the Parker Bayside PX, Alpha LP, Neugart PLE, Stober PE and Standard NEMA gearheads.

The PV Series is available in metric and NEMA frame sizes ranging from 40mm, 60mm, 90mm, NEMA sizes are NEMA 17, NEMA 23 and NEMA 34. Ratios are available in 3:1 thru 100:1.

Whether you're an OEM or an end-user searching for competitive alternatives, the PV offers a superior solution.

- Higher radial load capacity: Taper roller output bearings
- Competitive alternatives: Five drop-in output face options
- Universal mounting kits: Quicker deliveries and easier mounting
- Higher gear wear resistance: Plasma nitriding heat treating

Product Series	Gear Geometry	Configuration	Frame Sizes (mm)	Continuous Torque (Nm)	Radial Load (N)	Service Life (hrs)	Backlash
PV40/17	Planetary	In-Line	40 (NEMA 17)	3.5 to 6.7	375 to 575	<15	<6
PV60/23	Planetary	In-Line	60 (NEMA 23)	10.2 to 22.5	665 to 2535	<12	<4
PV90/34	Planetary	In-Line	90 (NEMA 34)	33 to 71	1040 to 4270	<10	<12

Rotary Servo Motors

Rotary Servo Motor Family Attributes

Series	SM	BE	MPP
Application requirements	Smooth motion, lower acceleration	Rapid moves, high acceleration	Rapid moves, high acceleration
Frame sizes	NEMA 16, 23	NEMA 16, 23, 34	7 sizes, 92 to 270 mm
Continuous torque range, Nm (in-lbs)	9.2x10 ⁻² to 1.3 (0.8 to 11.3)	0.2 to 5.2 (1.3 to 46.3)	1.5 to 135 (14 to 1384)
Speed range	0 to 7,500 rpm	0 to 5,000 rpm	0 to 5,000 rpm
Feedback	Encoder/Resolver	Encoder/Resolver	Encoder/Resolver/ SinCos - Hyperface/Sincos - Endat
Drive family	Aries, Compax3	Aries, Compax3	Aries, Compax3, AC890

SM Series

www.parker.com/em/sm



The SM Series brushless servo motors feature a slotless stator design that eliminates all detent torque in the motor, allowing the motors to provide extremely smooth motion, especially at low speeds. This design is also ideal for applications involving high-inertia loads (such as lead screws and belt drives).

- NEMA 16 and 23 sizes
- Up to 180 oz-in continuous torque
- Brushless construction
- Slotless design
 - Negligible detent torque
 - Reduced torque ripple
 - Higher rotor inertia
- Integrated planetary gearheads available
- TENV housing, IP65 option
- Custom modifications available
- Industry-leading delivery times
- CE compliant

Series SM	161	162	231**	232**	233**
Continuous stall torque Nm (oz-in)	0.2 (26)	0.3 (47)	0.4 (54)	0.7 (106)	1.1 (156)
Peak torque Nm (oz-in)	0.6 (78)	0.1 (141)	1.1 (160)	2.2 (316)	3.3 (467)
Rated speed (rpm)	7,500	7,500	7,500	7,500	5,800
Rotor inertia kg-m ² (oz-in-s ²)	1.1x10 ⁻⁵ (1.5x10 ⁻³)	1.8x10 ⁻⁶ (2.6x10 ⁻⁴)	5.2x10 ⁻⁵ (7.4x10 ⁻³)	9.3x10 ⁻⁵ (1.3x10 ⁻²)	1.4x10 ⁻⁴ (1.9x10 ⁻²)

*All specifications represent encoder feedback.

**Resolver version available with higher stall and peak torques.

BE Series

www.parker.com/em/be



The BE Series brushless servo motors produce high continuous stall torque in a cost-reduced package. The increased torque is the result of eight magnetic poles on the rotor instead of the four poles traditionally found on motors in these frame sizes.

The cost reduction is achieved from their open-lamination design. Unlike traditional servo motors, the BE Series motors do not have a metal housing. The laminations of the motor stator are shaped into the body of the motor, reducing material costs and motor assembly time.

- NEMA 16, 23, and 34 sizes
- Up to 5.2 Nm (741 oz-in)* continuous torque
- Brushless construction
- Eight-pole open-lamination design
 - Increased torque
 - Lower cost
- Integrated planetary gearheads available
- Custom modifications available
- Industry-leading delivery times
- CE compliant

Series BE	161	162	163	164	230*	231*	232*	233*	341*	342*	343*	344*
Stall torque, Continuous Nm (oz-in)	0.1 (21)	0.3 (37)	0.3 (47)	0.4 (61)	0.4 (53)	0.7 (94)	1.1 (155)	1.5 (207)	1.7 (239)	2.9 (406)	4.0 (566)	4.8 (686)
Peak torque Nm (oz-in)	0.5 (64)	0.8 (111)	1.0 (142)	1.2 (173)	1.1 (160)	2.0 (283)	3.3 (464)	4.4 (622)	5.1 (717)	8.6 (1,217)	12.0 (1,697)	14.5 (2,058)
Rated speed (rpm)	5,000	5,000	5,000	5,000	5,000	5,000	5,000	5,000	5,000	5,000	5,000	5,000
Rotor inertia kg-m² (lb-in-sec²)	1.3x10 ⁻⁶ (1.8x10 ⁻⁴)	2.0x10 ⁻⁶ (2.9x10 ⁻⁴)	2.7x10 ⁻⁶ (3.8x10 ⁻⁴)	3.5x10 ⁻⁶ (5.0x10 ⁻⁴)	5.2x10 ⁻⁶ (7.4x10 ⁻⁴)	9.1x10 ⁻⁶ (1.3x10 ⁻³)	1.7x10 ⁻⁵ (2.4x10 ⁻³)	2.4x10 ⁻⁵ (3.4x10 ⁻³)	3.1x10 ⁻⁵ (4.3x10 ⁻³)	5.0x10 ⁻⁵ (7.0x10 ⁻³)	6.9x10 ⁻⁵ (9.8x10 ⁻³)	8.2x10 ⁻⁵ (1.2x10 ⁻²)

*Resolver version available with slightly higher stall and peak torques.

MPP/MPJ Series

www.parker.com/em/mpp



The MaxPlusPlus (MPP) family of brushless servo motors is redefining performance, flexibility, and reliability. The industry's highest-performing servo motor uses eight-pole segmented lamination technology, which produces more torque in a shorter package. Use MaxPlusPlus motors for higher-torque applications, customization options, or when high performance is required. High inertia MPJ motors available for belt drive applications.

- 92 mm to 270 mm frame size
- Continuous stall torque from 14 in-lb (1.5 Nm) to 1,433 in-lb (162 Nm)
- Peak torque up to 4,537 in-lb
- Seven different feedback devices – Encoder, serial encoder, resolver, Heidenhain and Stegmann single- and multi-turn absolute encoders
- IP64 standard, IP65 optional
- Right-angle rotatable connectors

Series MPP	092x	100x	115x	142x	190x	230x	270x
Continuous stall torque range Nm (in-lb)	1.55 (14) to 4.0 (36)	4.6 (41) to 6.3 (56)	5.7 (51) to 9.8 (87)	11.1 (98) to 33.4 (295)	35.5 (315) to 62.4 (552)	80.3 (712) to 106.5 (942)	120.1 (1,063) to 162 (1,433)
Peak torque range Nm (in-lb)	4.93 (50) to 12.8 (113)	14.5 (129) to 20.1 (178)	18.1 (160) to 31.2 (277)	35.1 (311) to 106 (935)	113 (996) to 198 (1,750)	255 (2,252) to 337 (2,984)	380 (3,366) to 512 (4,537)
Rated speed (rpm)	3800 to 5000	4000 to 5000	1800 to 4000	2800 to 4000	2000 to 3000	1500 to 2000	800 to 1600
Rated output range (rpm)	0.5 to 1.6	1.5 to 1.9	1.6 to 2.7	3.4 to 7.0	8.3 to 11.8	11.6 to 14.1	12.1 to 20.3
Rotor Inertia kg-m²							
MPP	7.8x10 ⁻⁵	2.6x10 ⁻⁴	4.1x10 ⁻⁴	2.1x10 ⁻³	6.2x10 ⁻³	2.2x10 ⁻²	3.5x10 ⁻²
MPJ	4.2x10 ⁻⁴	8.2x10 ⁻⁴	1.1x10 ⁻³	8.3x10 ⁻³	–	–	–

Frameless Motors

Frameless Motors

www.parker.com/em/frameless



The Frameless Kit motors are ideal solutions for machine designs that require high performance in small spaces. The kit motor approach allows for direct integration with a mechanical transmission device, eliminating parts that add size and complexity. The use of frameless motors results in a smaller, more reliable motor package.

- Pre-installed integral commutation board is pre-aligned for easy assembly
- Rare earth magnets provide high flux in a small volume and high resistance to thermal demagnetizing
- Machined grooves securely lock magnets to rotor and ensure optimized radial location
- Class H insulation for high temperature operation (up to 155° C) meeting UL approved requirements
- High density copper winding for low thermal resistance and consistent performance across all motors
- Minimized end turns to maximize performance and minimize motor size
- Skewed laminations with odd slot counts reduce cogging for precise rotary motion with drastically reduced torque ripple even at low speeds
- Optimized torque-to-size ratio hand inserted to obtain highest slot fill possible maximizing ampere-turns

Frame Size	K032	K044	K064	K089	K375	K127	K500	K178	K700	K254
Stack Range: mm (in)	6.35 to 76.2 (0.25 to 3.00)					12.7 to 76.2 (0.50 to 3.0)				
Continuous Torque: Nm	0.044 to 0.33	0.119 to 0.96	0.31 to 2.91	1.307 to 7.13	1.715 to 6.69	3.94 to 16.1	3.05 to 15.4	10.12 to 43.1	5.05 to 27.5	18.78 to 80.9
(oz-in)	(6.3 to 46.5)	(17 to 136)	(44.3 to 410)	(186.7 to 1,004)	(245 to 942)	(563 to 2,263)	(435 to 2,170)	(1,445 to 6,078)	(722 to 3,876)	(2,683 to 11,400)
Peak Torque: Nm	0.095 to 0.99	0.357 to 2.88	0.93 to 8.73	3.92 to 21.4	5.14 to 20.1	11.83 to 48.3	9.14 to 46.2	16.18 to 69	8.09 to 44.0	30.04 to 129.4
(oz-in)	(13.5 to 139.5)	(50 to 408)	(133 to 1,230)	(560 to 3,012)	(734 to 2,826)	(1,690 to 6,789)	(1,306 to 6,510)	(2,312 to 9,724)	(1,155 to 6,200)	(4,292 to 18,240)
Km: Nm/W	0.009 to 0.054	0.02 to 0.13	0.048 to 0.33	0.164 to 0.631	0.153 to 0.592	0.29 to 1.18	0.224 to 1.13	0.627 to 2.68	0.314 to 1.53	1.043 to 4.49
(oz-in/W)	(1.25 to 7.56)	(3 to 18.3)	(6.88 to 46.6)	(23.36 to 88.9)	(21.8 to 83.4)	(41.4 to 166.1)	(32 to 159.3)	(89.6 to 377)	(44.8 to 215)	(149 to 632)

Servo Drives and Controller Drives

Servo Drive Family Attributes

Series	ViX	Aries	Gemini	Compax3
Input power	24 to 80 VDC	120/240 VAC	120/240 VAC	120/240/480
Shaft power, continuous at 3,000 rpm	Up to 5 A RMS, 2 power levels	Up to 16 A RMS, 7 power levels	Up to 14 A RMS, 5 power levels	up to 100 kW
Feedback	Encoder/Resolver	Smart Encoder, Quadrature encoder, Endat absolute encoder	Encoder/Resolver	Encoder, Resolver, Sincos, Endat, Sincos Hiperface, SSI
Inputs/Outputs	5 inputs 3 outputs	7 inputs 4 outputs	8 inputs, 6 outputs, expandable (GV6K)	8 inputs, 4 outputs expandable
Command input	±10 V analog step/direction CW, CCW encoder input	±10 V analog step/direction CW, CCW encoder input	±10 V analog step/direction CW, CCW encoder input	±10 V analog 5 V step and direction encoder input
Controller version available	Yes	Yes	GV6, GV6K	T11, T30, T40*
Fieldbus communications		ETHERNET Powerlink		Profibus, DeviceNet, CANopen, ETHERNET Powerlink
Compatible motor type	Standard brushless servo motor	Standard brushless servo motor	Standard brushless servo motor	Brushless servo
Compatible Parker motor	SM, BE, MPP, MX80, LX80	MPP, SM, BE Trilogy Linear	MPP, SM, BE Trilogy Linear	MPP, SM, BE

*T11 - Basic indexer, T30 - Full programmable IEC61131-3; T40 - T30 plus electronic camming, gearing, PLS, etc.

ViX Series

www.parker.com/em/vix



The ViX Series of servo drives and controller drives is flexible, powerful and compact. The ViX offers a high-resolution encoder feedback option for optimal use with linear servo motors, such as the MX80. Choose the ViX for low-cost multi-axis drive applications or for powerful but compact standalone drive/controller applications.

- 24 to 80 VDC input
- 2.5 and 5 A RMS continuous versions available
- Torque, velocity, or position control
- Resolver or encoder feedback (software selectable)
- High-resolution encoder feedback option
- Five digital inputs and three digital outputs
- CE (EMC and LVD), UL compliant
- CANopen and RS485 option
- Controller versions available

Aries Series

www.parker.com/em/aries



The Aries Series of digital servo drives is the easiest to use servo drive on the market. There is no setup, as it auto-configures to any Compumotor motor with smart encoder. With Aries, you only pay for what you need, as it is an optimized torque drive for use with a centralized controller and no additional circuitry. Choose the Aries for hassle-free, low-cost multi-axis torque drive applications.

The Aries Controller combines the versatile and cost-effective Aries digital servo drive platform with the advanced control capabilities of the ACR servo controller. Enjoy the benefits of single-axis (Aries Controller) or multi-axis (ACR9000) servo control within the same ACRView software environment.

- 120/240 VAC input
- 100, 200, 400, 750, 1300, 2000 and 3000 Watt power levels
- Up to 16 A RMS continuous, 48 A RMS peak current
- Auto-configuration
- Torque or velocity control and step/dir control
- Smart encoder, quadrature encoder, or EnDat absolute encoder feedback
- CE (EMC and LVD) and UL compliant
- ETHERNET Powerlink motionbus available
- Controller version available

Gemini Series

www.parker.com/em/gemini



The Gemini Series is a family of servo drives and controller drives that covers an extremely wide range of motion control applications. The Gemini is available in three control levels (drive only, basic controller drive, and full-featured controller drive) and five power levels. Choose the Gemini when you need to be flexible or want to mix and match drives but keep the same connectivity and front-end software.

- 120/240 VAC input
- Torque, velocity, or position control
- Five power levels from 2 to 14 A RMS continuous current

Gemini GV Digital Servo Drive	Gemini GV6 Digital Servo Drive with Basic Controller	Gemini GV6K Digital Servo Drive with Full-Featured Controller
Torque, velocity, step and direction	Basic motion	Position-based following
CW/CCW/Encoder tracking mode	Registration	Multi-tasking
Wizard-based setup	Conditionals	Scaling
	Integer variables	High-level variables
	RS232 and RS485 standard	300 k memory
	8 inputs and 6 outputs	RS232, RS485, and Ethernet standard
		8 inputs and 6 outputs onboard
		Up to 256 expansion I/O optional

Compax3

www.parker.com/em/compax



With its high-performance and modular design, the Compax3 family of industrial servo drives and drive/controllers offers a new level of servo performance and flexibility.

Enhanced by the IEC61131-3 programming environment, the modular structure of the Compax3 family allows options such as intelligent motion controllers, fieldbus interfaces and industry standard motor feedback.

In addition, numerous expansion options can be added to the standard product in order to optimize the capabilities required for today's demanding servo applications.

- Available in both 120/240 VAC and 480 VAC input versions
- Certified safety technology integrated into drive (EN954-1 Category 3)
- Continuous current output from 2.5 A (rms) to 155 A (rms) (up to 75 kW of power)

- Fieldbus options: DeviceNet, Profibus, CANopen, ETHERNET Powerlink and RS232
- Supports all five IEC61131-3 programming languages and continuous flow chart with CoDeSys interface
- Resolver, encoder or high-resolution Sin/Cos[®] Absolute rotary encoder feedback (single- or multi-turn) – also supports Hiperface, Endat 2.1 and SSI feedback devices
- Internal regeneration circuitry; external resistor connections for additional power dissipation
- Easy-to-use wizards-based configuration and programming via C3 ServoManager™ software package
- Full diagnostic, auto tuning and 4-channel oscilloscope tools provided in the standard C3 ServoManager™ software
- CE (EMC and LVD), UL and cUL recognized

Stepper Drives and Controller Drives

Stepper Drive Family Attributes

Series	E-AC	E-DC	ViX
Power input	95 to 132 VAC	24 to 48 VDC	24 to 80 VDC
Peak current output (Amps)	0.02 to 3.5	0.2 to 4.8	0.2 to 8
Overall dimensions mm (in)	109.22 x 57.15 x 48.26 (4.3 x 2.25 x 1.9)	127 x 91.44 x 40.64 (5.0 x 3.6 x 1.6)	124.46 x 86.36 x 43.18 (4.9 x 3.4 x 1.7)
Control version	CP*E-AC	EX-DC	ViX250IM, ViX500IM
Control version features	Basic position, velocity or acceleration controls	Sequence select, position maintenance, stall detection, following, 6 inputs/3 outputs	Motion profiles, conditionals, registration position maintenance stall detection, following, 5 inputs/3 outputs

E-AC and E-DC Microstepping Drives

www.parker.com/em/e-ac
www.parker.com/em/e-dc



The E Series is a high-performing, low-cost family of packaged AC-input and DC-input microstepping drives.

- Anti-resonance circuitry suppresses mid-range instability
- Recommended motor inductance range of 0.5 mH to 80 mH
- Selectable resolution up to 50,800 steps/rev
- Auto standby reduces motor current (and heating)
- Current waveforms to optimize smoothness
- Optically isolated step and direction inputs
- Short-circuit and over-temperature protection

ViX Microstepping Controller Drives

www.parker.com/em/vixstep



The ViX Series is a digital, compact, and high power family of DC-input microstepping drives.

- Wizard-based configuration
- Anti-resonance circuitry suppresses mid-range instability
- Recommended motor inductance range of 0.5 mH to 20 mH
- Five digital inputs and three digital outputs
- One analog input
- Controller version provides basic control functionality
- RS485 and CANopen version also available

LV/HV Series Stepper Motors

www.parker.com/em/lvhw



The LV/HV Series is optimized for use with the E-Series microstepping drives and controller drives. The LV motors are available in five frame sizes, and the HV are available in three frame sizes, so it is easy to choose the optimal speed and torque combination.

- LV – 11, 14, 17, 23, and 34 frame sizes
- HV – 17, 23, and 34 frame sizes
- Single, double, or triple stack lengths available
- LV – up to 80 VDC windings
- HV – up to 170 VDC windings
- Single or double shaft options
- Flying leads or 10 foot cable options
- Customization available

ACR Motion Controllers

ACR Motion Controllers

www.parker.com/em/acr



The ACR Series of controllers are among the highest performing controllers on the market. Powerful, yet efficient, project development software makes this family an attractive choice regardless of application complexity.

Connectivity and communication features give the ACR controllers flexibility for use in a wide variety of machine architectures. The ACR family excels as a standalone machine and motion controller, interfacing with a PC or working alongside a PLC. A powerful DSP makes the ACR Series an outstanding multi-tasking servo controller.

Parker System Solutions

The ACR family is the controller of choice when a complete Parker motion system is needed. Seamless communication to drives and HMI combine with motion algorithms tailored to precision mechanics for a complete high performance system.

Hardware Features

- Up to 16 axes of servo or stepper control
- ±10 V analog or step-and-direction command output
- 24 VDC optically isolated onboard inputs and outputs
- Absolute encoder support via SSI

Motion Control Features

- Multi-tasking of up to 24 simultaneous programs
- Interpolation of eight axes in any combination
- Linear interpolation of up to eight axes
- Segmented electronic CAM
- Electronic gearing with real-time phase advance
- Programmable limit switch with multiple sources
- Advanced gantry control
- 3D arcs and tangent axis control
- Hardware and capture registers
- Time-based moves
- S-curve profiling
- Backlash and ballscrew compensation
- High-speed (1 μs) hardware position capture registers

Communication Features

- Ethernet 10/100 Base-T
- USB 2.0
- CANopen
- ETHERNET Powerlink
- EtherNet/IP™ connectivity
- Visual Basic and Visual C++® libraries
- .NET and ActiveX™ communication controls
- Parker Interact and InteractX compatible via Ethernet

Series	Bus Type	Number of Axes	Command Output
9000	Ethernet, USB	1 to 8	Servo, Stepper
9030	Ethernet, USB	1 to 16	Servo, Stepper, ETHERNET Powerlink
9040	Ethernet, USB	1 to 16	ETHERNET Powerlink
1505	PCI	1 to 4	Servo, Stepper
8020	PCI	1 to 16	Servo, Stepper

Real-Time Ethernet Motion Control

ETHERNET Powerlink (EPL)

www.parkermotion.com/powerlink



ETHERNET Powerlink (EPL) expands the ACR family by enabling real-time motion control via Ethernet. The high-bandwidth digital communications network enhances machine performance and configuration possibilities while reducing set-up time and installation complexity.

ETHERNET Powerlink is a deterministic, real-time Ethernet motion bus solution connecting motion controller to servo drives and I/O points using standard Ethernet hardware. EPL is an open standard communication protocol, developed to achieve the timing and synchronization required in high performance automation and motion control applications.

Parker's EPL solution includes all the motion and communication features of the ACR family for complete motion and machine control solutions. A full range of servo drives is available with Aries and Compax3 Series drives, supporting a wide variety of motors and feedback devices. All drive and motor configuration, programming and system troubleshooting can be accomplished through the ACR controllers.

EPL Highlights

- Open industry standard communication protocol
- Standard Ethernet hardware
- No proprietary ASICs required
- Based on CANopen device profiles
- Simplified system design
- Reduced installation time
- Enhanced diagnostics

Parker EPL Solutions

- Up to 16 axes with ACR controllers
- Aries and Compax3 servo drives
- Built-in repeating hubs for flexible connection options
- Drive and controller on-board I/O
- Single point of communication for entire motion system
- Auto-tuning and motor configuration via ACR-View

ETHERNET 
POWERLINK
Standardization Group

Human-Machine Interfaces

HMI Software

Parker offers the right HMI solution for your application:

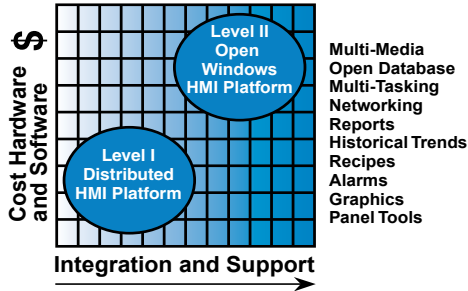

Level I* Distributed HMI Platform:

Parker's Interact Xpress HMI software comes pre-installed on our XPR Series PowerStations. Interact Xpress is suitable for applications ranging from simple pushbutton replacement through to multi-station HMI's on large machines. Interact Xpress offers unique distributed HMI capability that allows you to design, edit and run your applications on the PowerStation, in Internet Explorer or in an offline development application. This capability simplifies and dramatically cost reduces remote support for HMI.

Level II* Open Windows® HMI Platform:

Parker's InteractX software comes pre-installed on both our EPX and HPX families of PowerStations. InteractX enables operator interface functionality for higher-level applications including networking, open database integration and multimedia support options. InteractX is especially suited to applications that require maintaining an audit trail such as 21CFR11, the USA Patriot Act and Sarbanes-Oxley.

Supports Auto Tag Creation for popular controllers

* Parker's HMI solutions play well with others: Interact Xpress can serve applications to any supervisory HMI that supports a web browser tool - reducing application development times by up to 80%. When paired with InteractX Xpress even provides tag sharing so that X can perform the aggregation and analysis of system wide data.

Level I: Interact Xpress HMI Software and XPR PowerStations

www.parkermotion.com/xpress
www.parker.com/em/interact



XPR PowerStations and Interact Xpress provide a powerful, cost-effective solution for Level 1 applications.

XPR PowerStations are available in the following display sizes: 0" (No Display), 6", 8", 10.4" and 15".

Every PowerStation includes:

- Interact Xpress Runtime Software
- Web Publishing Capability Integrated
- Compact Flash Storage, RS-232 (1), RS-232/422/485 (1) Serial Ports
- 10/100 BaseT Ethernet
- TFT Display with an analog resistive touchscreen
- NEMA Type 4/4X Bezels
- 24 VDC Power
- CE/UL/CUL agency approvals C1D2 (Optional)

Interact Xpress Software:

- Intuitive development environment reduces development costs
- Learn the Software once; same development environment is available on the PowerStation, in Internet Explorer and in the Interact Xpress Manager offline tool
- Over 35 Communications drivers included
- Simultaneous multiple device communication with data transfer
- Advanced security for single- and multi-user applications, with separate local and remote privileges
- Multimedia support with .jpgs and .swf files
- Web publish from any XPR PowerStation over any IP connection to Internet Explorer

Drives & Controllers

Level II: InteractX™ HMI Software and EPX/HPX PowerStations

www.parker.com/em/hpx
www.parker.com/em/epx
www.parker.com/em/interactx



EPX PowerStations provide a bundled Level II hardware and software solution at a price point that is competitive with most Level 1 solutions. EPX PowerStations are available in the following display sizes: 8", 10.4" and 15").

Every EPX PowerStation includes:

- 650 MHz Celeron ULV CPU
- 512 MB DRAM
- Windows XP Professional
- 80 GB hard drive (compact flash optional)
- External compact flash slot
- (1) RS-232, (1) RS-232/422/485 serial ports
- 10/100 BaseT Ethernet

HPX PowerStations are fully configurable industrial PCs that are bundled with InteractX HMI runtime software pre-installed. They are available in 10", 15" and 17" display options with CPU options ranging from a Celeron 2.0 GHz to a Pentium 4 2.8GHz.

InteractX is Parker's award winning Windows based Level II HMI software.

Software features include:

- Panel tools
- Industry leading graphics
- Alarming
- OPC Client and Server
- Over 50 communications drivers
- ActiveX support
- Integrated Visual Basic® for applications
- Multi-language support
- "Easy E-Sigs" no scripting required tools for audit trail and 21CFR11 compliance
- Direct Tag import and auto-creation for popular controllers
- Database logging

HPC PowerStations

www.parker.com/em/hpc



Parker's industrial PC products include 10", 15", and 17" panel mount color touchscreen systems and a machine-mount PC only system. The HPC PowerStation line of PC workstations is designed and tested to extremes and delivers more processor, media, and connectivity performance for your money.

- 2.0GHz Celeron or 2.8GHz Pentium 4 CPU
- Up to 2GB DDR SDRAM
- Intel Extreme Graphics
- 80GB EIDE hard drive (160GB HDD or compact flash optional)
- 4 USB 2.0/1.1 ports
- (3) RS-232, (1) RS-232/422/485 serial ports
- 10/100 BaseT Ethernet
- External audio
- Parallel port
- PC-only system:
 - Hardened industrial PC
 - Use with our PHM monitors or any 3rd party display
 - Keyhole mounting

PHM Industrial Monitors

www.parker.com/em/indmonitors



This family of industrially hardened monitors is perfect for harsh environments. They feature a chemical-resistive NEMA 4/4X front bezel and convenient clip mounting, while offering standard VGA and serial connections for video and touchscreen.

- Analog resistive touchscreen
- On-screen display controls
- Auto power sensing and sleep mode
- Stainless steel bezel available on 15" models
- 24VDC power
- CE, UL and CUL agency approvals standard
- Class 1 Div. 2 available

Display sizes:

- 15" XGA (1024 x 768)
- 17" SXGA (1280 x 1024)

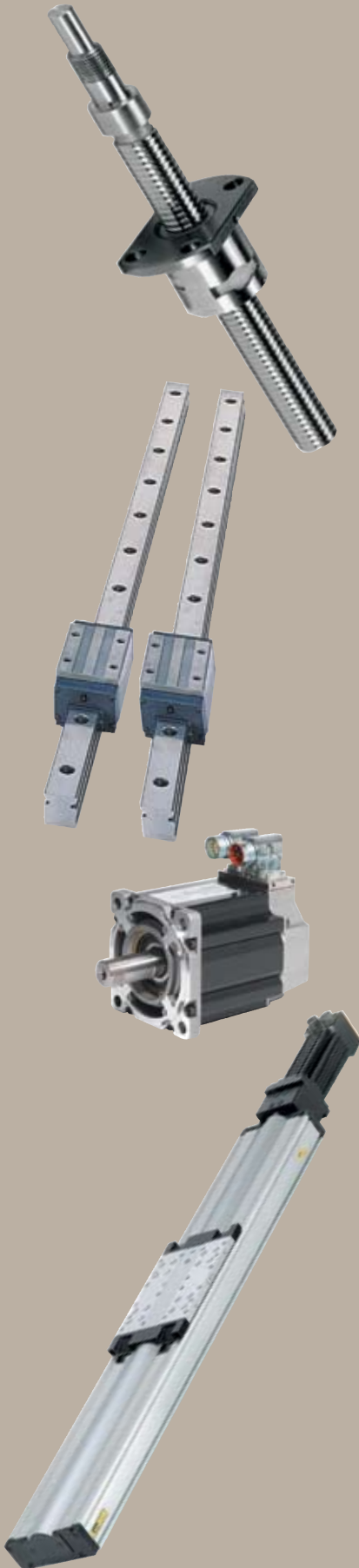

Engineering Reference for linear motion and mechanics

With over 80 years of motion and control experience Parker Hannifin has the engineering expertise to assist in design, development, and production of various automation projects. The following pages detail some of the engineering considerations when dealing with electromechanical motion control. In a changing business environment where business partnerships are more important than ever, Parker is pleased to offer the engineering excellence a company should expect from a premier partner. Whether the question is about thermal effects on submicron accuracies, outgassing materials in a vacuum rated environment, particulate generation in a clean room environment, or simply critical speeds of ground versus rolled ball screws; Parker has experience in providing proven solutions

Contents

298-299	Overview
300-304	Linear Mechanics
305-310	System Considerations
311-313	Electronic Components
314-321	How to Size and Select
322-324	Complete System Analysis
325-326	Additional Glossary of Terms

Engineering Reference Overview



Electromechanical motion systems utilize various technologies as building blocks for obtaining point to point, scanning, and contouring motions. These technologies or components include (but are not limited to):

- Ballscrews (rolled, ground, or whirled)
- Leadscrews (rolled or ground)
- Belt drives (herringbone design or trapezoidal tooth design)
- Linear motors (ironless, ironcore, or back iron designs)
- Cross roller bearings (standard and anti-cage creep designs)
- Square rail bearings (precision and standard designs)
- Roller bearing wheels (steel or polyamide designs)
- Round rail bearings (bushing and recirculating ball designs)
- Motors (DC, Stepper, and Servo designs)
- Encoders (Linear, Rotary, Absolute, Incremental)
- Amplifiers (also known as drives)
- Controllers (single and multi-axis)
- HMI (Touch screen user interface devices)



By understanding the trade-offs in technologies (for example between a precision ground ball screw versus a rolled ball screw or a servo motor versus a stepper motor) engineers are more efficient in designing the right motion solution. The following pages are intended as a resource for trying to understand the benefits of the technologies and other important things to consider when designing a motion system.

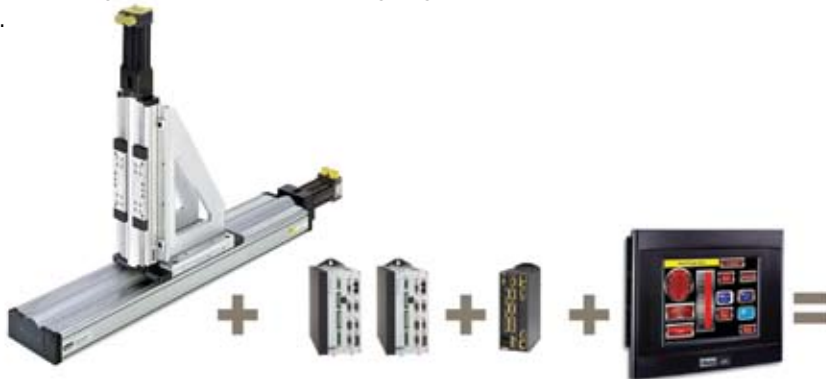

System Variables and Parameters

The following diagram represents a product tree of a modeled positioning system. The upper section represents various System Variables, which describe the STATIC, SERVO and DYNAMIC specifications of the machine. These variables are modeled as a function of system parameters as shown below.

The bottom section of the diagram represents system parameters that characterize the various motion control components of the positioning system. These parameters are needed to be selected for various reasons including structural design, component sizing, and servo tuning. The model relates these parameters to the performance variables as shown above. It can therefore be used to assist in the selection of these parameters to result in a cost-effective solution.

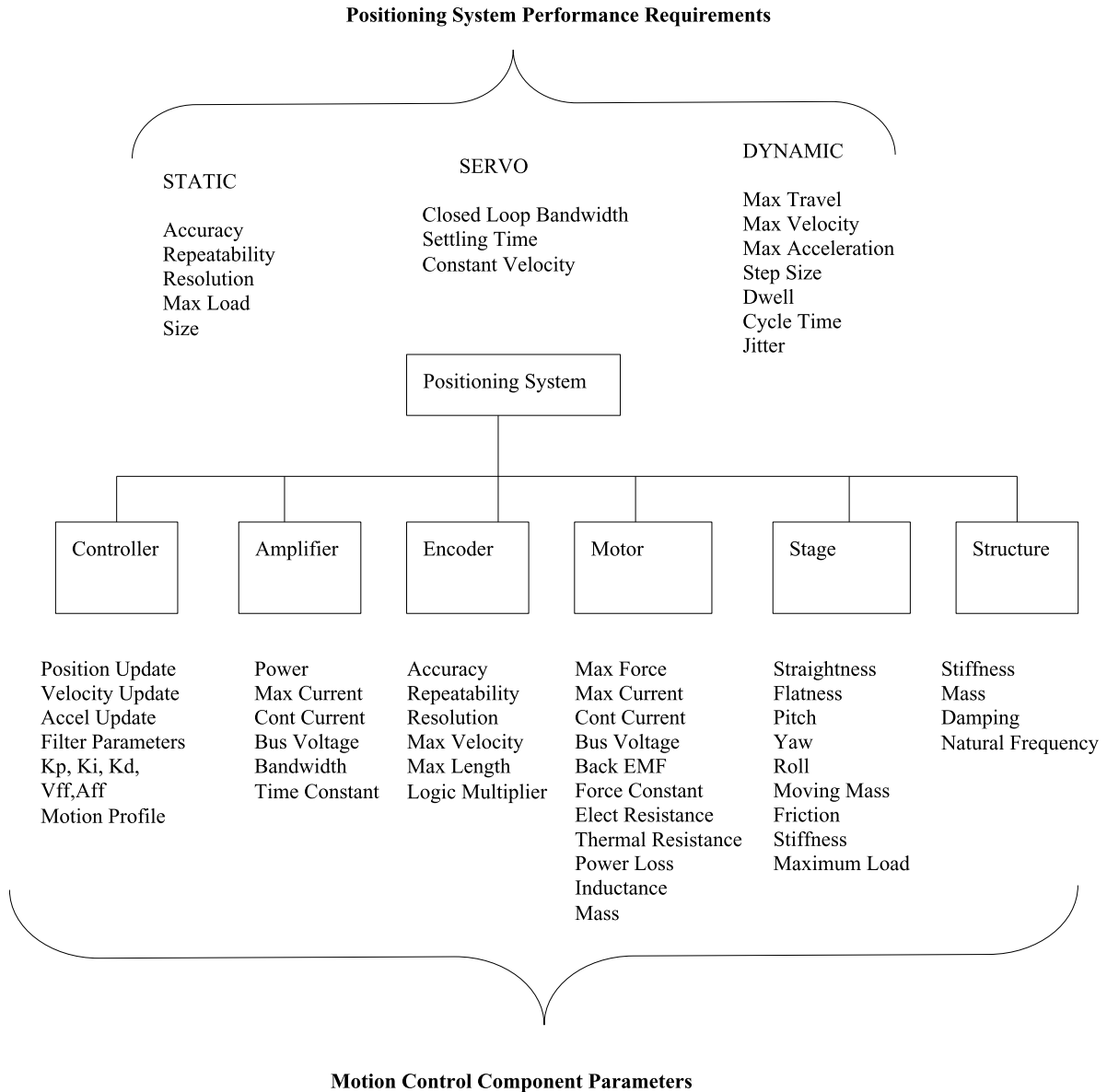

Linear Positioner Components:

Bearings:

Recirculation Bearing

Typically used for highest stiffness and high speed (Pitch, Yaw and Roll on the order of 10 arc-sec).

Crossed Roller Bearing

Typically used for a combination of high stiffness and high smoothness of motion (Pitch, Yaw, Roll on the order of 5 arc sec).

Air Bearing

Typically used for highest precision (sub micron) and highest smoothness of motion. (Pitch, Yaw, Roll on the order of 1 arc-sec).

Drive Transmission:

Ball Screw

Typically used for high acceleration, high force.

Lead Screw

Typically used for high smoothness of motion.

Linear Motor (Ironless)

Typically used for very high smoothness of motion at low or high velocity.

Linear Motor (Iron Core)

Typically used for achieving a combined high force (up to 20,000 N), long travel (unlimited) and high speed (up to 10 m/sec).

Belt Drive

Typically used for high speed applications.

Motors:

See page 310.

Encoders:

Rotary Encoder

Typically mounted to the back of a rotary motor and used for lower precision at lower cost.

Linear Encoder

Typically used for higher precision at higher cost.

Rotary to Linear Conversion

Linear motion systems driven by rotating electric motors commonly employ one of three rotary-to-linear conversion systems: ballscrew, acme screw or belt drive.

Leadscrew

Screw-drive mechanisms, whether Acme screw or ballscrew, provide high thrust (to thousands of pounds) but are often limited by critical speed, maximum recirculation speed of ball nut circuits, or sliding friction of Acme nut systems.

Ballscrew

The majority of linear motion applications convert motor torque to linear thrust using ballscrews due to their ability to convert more than 90% of the motor's torque to thrust. As seen below, the ball nut uses one or more circuits of recirculating steel balls which roll between the nut and ball screw threads. Ballscrews provide an effective solution when the application requires:

- High efficiency, low friction
- High duty cycle (>50%)
- Long life, low wear

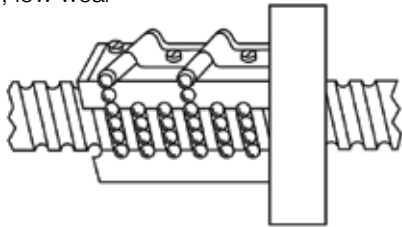

Acme Screw

The acme screw uses a plastic or bronze solid nut that slides along the threads of the screw, much like an ordinary nut and bolt. Since there are no rolling elements between the nut and the lead screw, acme screws yield only 30-50% of the motor's energy to driving the load. The remaining energy is lost to friction and dissipated as heat. This heat generation limits the duty cycle to less than 50%. A great benefit of the acme screw is its ability to hold a vertical load in a power-off situation. The acme screw is a good choice for applications requiring:

- Low speeds
- Low duty cycles (50%)
- The ability to hold position while motor power is off

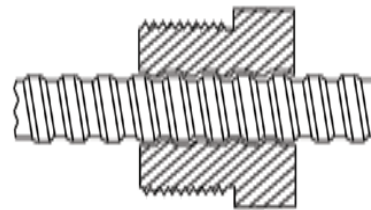

Ballscrew/Leadscrew Comparison

Considerations	Acme Screw	Ballscrew	Comments
Audible noise	Quiet operation	Noisy	Acme screws are quieter, while one can hear the ball bearings recirculating within a ballscrew. In any case, the motor sound is typically the most audible part of the cylinder assembly.
Back-driving loads	Self-locking	Easily backdrives	When vibration is apparent in a system, an acme may backdrive. Ballscrews may require a brake.
Backlash	Increases with wear	Constant throughout life of screw	Due to high friction, acme screws wear sooner, and therefore, the backlash increases over the life of the leadscrew.
Duty cycle rating	Low/Medium (<60%)	High (100%)	Because excessive heat can deform the screw, acmes are limited to 60%. The high efficiency of ballscrews allows for 100%.
Efficiency rating	Low: Plastic nut (45%) Bronze nut (35%)	High (90%)	Acme screw ratings are lower due to sliding friction while ballscrews are higher due to rolling contact.
Life (mechanical wear)	Shorter life due to high friction	Longer	Acme screw life is load dependent and is rated in travel distance. The higher the load, the shorter the travel life. (See life expectancy charts for ballscrews)
Smoothness of operation	Smooth operation at lower speeds	Smooth operation at all speeds	Ballscrews are generally smoother at all operating speeds.
Speeds	Low	All	Ballscrews operate well at all speeds, while Acme screws are best suited for lower speed applications.

Screw Characteristics and Effects of Changes

Feature	Change	Effected Performance	How
Screw Lead	Faster Lead	Required Torque	Increases
Screw Lead	Faster Lead	Load Capacity	Increases
Screw Lead	Faster Lead	Accuracy	Decreases
Screw Lead	Faster Lead	RPM required for same speed	Decreases
Screw Lead	Faster Lead	Ball Bearing Diameter	Increases
Load Capacity	Increases	Life	Decreases
Screw Length	Increases	Critical Speed	Decreases
Screw Length	Increases	Column Loading Capacity	Decreases
Screw Diameter	Larger Diameter	Load Capacity	Increases
Screw Diameter	Larger Diameter	Column Loading Capacity	Increases
Screw Diameter	Larger Diameter	Stiffness of Screw	Increases
Screw Diameter	Larger Diameter	Spring Rate	Increases
Screw Diameter	Larger Diameter	Critical Speed	Increases
Screw Diameter	Larger Diameter	Screw Inertia	Increases
Screw Mounting	Increase Rigidity	Critical Speed	Increases
Screw Mounting	Increase Rigidity	System Stiffness	Increases
Ball Nut Length (1)	Lengthen	Load Capacity	Increases
Ball Nut Length (1)	Lengthen	System Stiffness	Increases
Ball Bearings per Nut	More Bearings	System Stiffness	Increases
Ball Bearings per Nut	More Bearings	Load Capacity	Increases
Preload Force of Nut	Increase Preload	Continuous torque	Increases
Preload Force of Nut	Increase Preload	Positional Accuracy	Increases
Preload Force of Nut	Increase Preload	System Stiffness	Increases
Preload Force of Nut	Increase Preload	Finest Resolution	Decreases
Ball Diameter in Nut	Larger Diameter	Life	Increases
Ball Diameter in Nut	Larger Diameter	System Stiffness	Increases
Ball Diameter in Nut	Larger Diameter	Load Capacity	Increases

(1) Note 7 turn Max

Attribute Comparison of Drive Technologies

	Leadscrew with Composite Nut	Leadscrew with Bronze Nut	Ballscrew with Rolled Threads	Ballscrew with Ground Threads	Belt Drive
Smoothness	Excellent	Excellent	Fair	Good	Fair
Positional Accuracy	Excellent	Excellent	Fair	Excellent	Fair
Positional Repeatability	Excellent	Excellent	Good	Excellent	Fair
Axial Load Capacity	Low	Moderate	High	High	Moderate
Axial Stiffness	Fair	Good	Very Good	Excellent	Low
Speed	To 15 RPS	To 25 RPS	To 40 RPS	To 40 RPS	120 inches/sec
Duty Cycle	50%	75%	100%	100%	100%
Where used	PROMech MX80	Legacy Products	HD	400XR HD MX80 800CT	HPLA HLE

Timing Belt

Belt drive systems offer many of the benefits of ball screws, yet have fewer moving parts, and do not have the critical speed limits of leadscrew-driven systems. They generally provide greater linear motion from the same motor movement, resulting in higher travel speeds with minimal component wear. In contrast, this design results in lower repeatability and accuracy. Thrust capability is also less compared to screw-drive systems due to the tensile strength limitation of the transport belt.

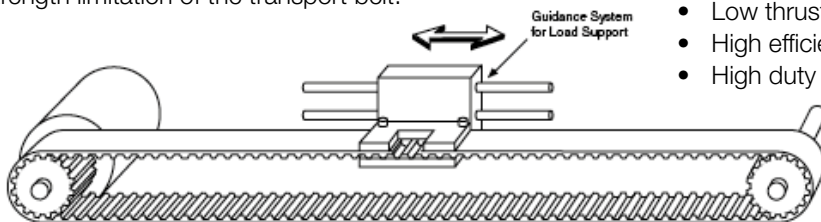

A toothed belt passes around a pulley in each end of the actuator and is attached to the carriage to pull it back and forth along the length of travel. The carriage is supported by a linear bearing system to provide load carrying capacity. The belt is reinforced with steel tensile elements to provide strength and minimize belt stretch. Timing belt systems are a good solution for applications requiring:

- High speeds
- Low thrusts
- High efficiency
- High duty cycle

Backlash

The clearance between elements in a drive train or leadscrew assembly which produces a mechanical “dead band” or “dead space” when changing directions is known as the backlash in a system.

In most mechanical systems, some degree of backlash is necessary to reduce friction and wear. Usually 0.006 - 0.008” is attributed to the lead screw/nut assembly. For ballscrews, backlash will remain constant throughout the life of the actuator, while acme screws will increase backlash with wear.

Reducing the Effects of Backlash

1. Approach a stop position from the same direction.
2. Apply a constant linear force on the cylinder thrust tube or carriage. This is done automatically for cylinders used in vertical orientations with a backdriving load.
3. For programmable positioning devices, it is possible to program out backlash by specifying a small incremental move (enough to take out the backlash) prior to making your normal moves in a particular direction.
4. Use a preloaded nut on a lead screw to counteract the backlash. Contact Actuator Division about the precision ground screw option which reduces backlash in the drive nut.
5. An inline actuator with the motor directly coupled to the leadscrew has less backlash than parallel or reverse parallel units which utilize a gear train or drive belt/pulley.

Primary Sources of Backlash

Drive Nut/Lead Screw Assembly

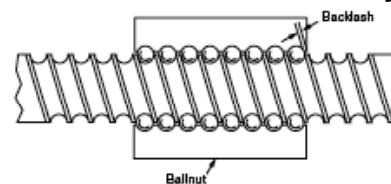

Drive Train (Gears, Timing Belt/Pulley)

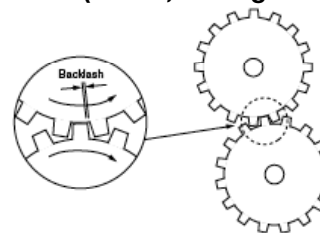

Timing Belt/Pulley

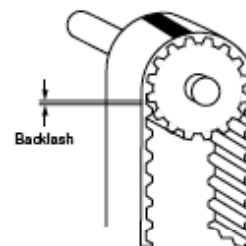

Coupling

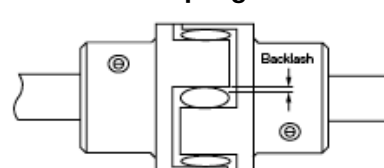

Bearing Characteristics

	Cross Roller	Round Rail	Square Rail	Slider/Bushing	Roller Wheel
Normal Load Capacity	High	Medium	Med-High	High	Med
Accuracy	High	Medium	Med-High	Low	Med-Low
Stiffness	High	Low	Med	Low	Med-Low
Preload	High	Low	Medium	Medium	Medium
Moment Loading	High	Low	Medium	Low	High
Single Rail Support	No	No	Yes	Yes	No
Same Load in All Directions	Yes	No	Yes	No	Yes
Sealing	No	Yes	Yes	No	Yes
Smoothness	Medium	High	Med-High	low - High	Med
Drag	Med- Low	Low	Med	High	Low
Ease of Install	Med	Simple	Med-Simple	Simple	Med
Mounting Surface Precision Required	High	Medium	Med-High	Low	Low
Self Aligning	No	Yes	No	No	Yes
Life	Med	Medium	High	Low	High
Cost	High	Low	Medium	Low	Med-Low
Continual support needed	No	Yes	Yes	Yes	Yes
Load Cap/Size	High	Low	Med-High	High	Medium
Efficiency	High	High	Medium	Low	Med-High
Velocity Ripple	Low	Low-High	Med-High	High	Med-High

Round Rail Linear Bearings

Round rail bearings are a recirculating type linear bearing consisting of a large diameter centerless ground rod on which ball bushings ride. The design allows very long travel lengths which are only limited by the available rail and base length. The ball bushing with its recirculating ball bearings, provide good load capacity with very low friction. With its modular design, the bearing components can be replaced easily. These bearings are ideal for assembly and automation applications where high speed, long life and fast low cost maintenance is a must.

Ball and Rod Bearings

Ball and rod bearings consist of two rows of hardened steel balls each pre-loaded between four hardened ground 440C stainless steel rods. This design provides ultra smooth extremely low friction motion by reducing the contact area between the balls and the ways. This design provides extremely good straight line and flatness accuracy.

Square Rail Linear Bearings

Also known as linear guides, these bearings are very similar to the round rail bearing. The major difference is in the shape of the rail and the bearing ways. Square rail bearings have a square or rectangular cross section that enables bearing ways to be ground into the sides of the rail. These bearing ways are shaped in an arch which is approximately the same radius as the ball bearing. This increases the contact surface between the ball and the rail thereby increasing the load capacity of the linear bearing. As with the round rail, travel is only limited by the available base and rail length.

Cross Roller Linear Bearings

Very similar to the ball and rod bearing except the balls have been replaced by rollers and the rods by ground “V” ways. These changes increase the load capacity of this type of bearing up to 2-3 times that of an equivalent size ball and rod bearing. The straightness and flatness specification of these tables is excellent.

Assembly

Configurations:

Single Axis



The simplest form of positioning stage. Sometimes referred to as “Table”, “Slide”, “Actuator” or “Stage”. It typically consists of slide, base, bearing, motor, encoder, limits, home, cable carrier and hard stops. The base can be mounted to a rigid structure or to the slides of other stages in various configurations as shown below. The slide, which is the moving part, can be used to move another stage, or any object such as a tool, work, test and measuring devices.

Compound XY

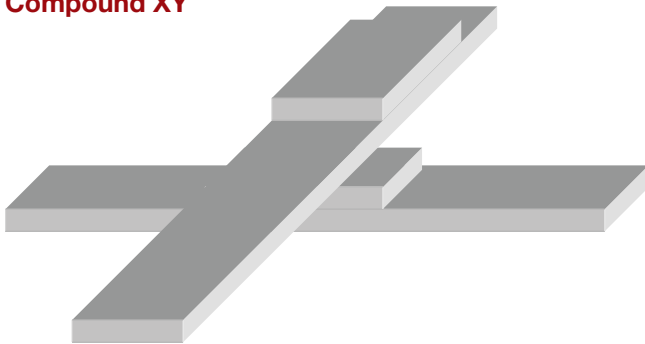

This configuration provides the simplest form of 2 linear degrees of freedom of a positioning system where the base of the top axis is bolted to the slide of the lower axis. For a high-performance positioning application, a “monolithic” design can be used where the base of the top axis and the slide of the bottom axis are rigidly made as a single part. In a compound XY configuration care should be given in consideration to the Abbe Error of the top axis due to cantilever “diving board” effect.

Compound XYZ

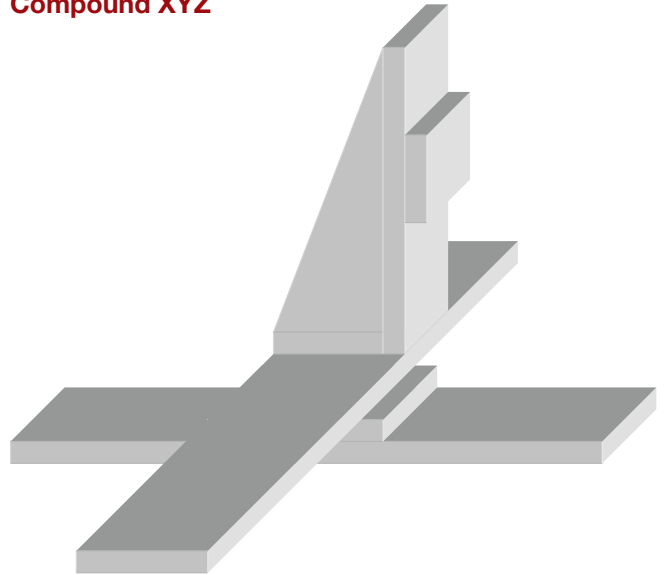

This configuration provides the simplest form of 3 linear degrees of freedom of a positioning system with the smallest footprint. In using this configuration care must be given to calculate the three dimensional accuracy. In particular the Abbe error. (Due to large offset between the bearing of the lowest stage and the point of interest at the top of the vertical stage.)

Split XYZ Axes

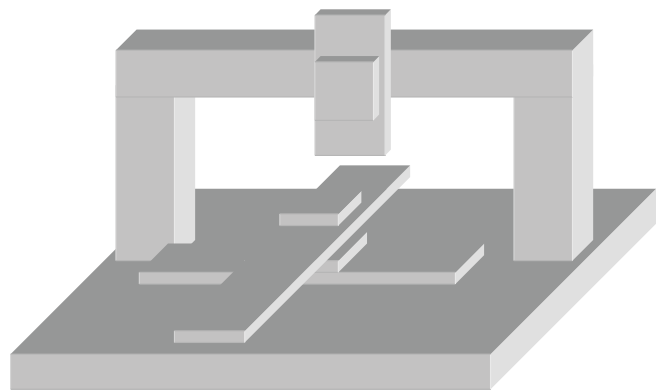

A split axes positioning stage typically provides higher precision and higher stiffness than a compound configuration of the same number of axes. The reason is that at least 2 axes are mounted to a flat, rigid, stationary base with a fewer number of stages that ride on other stages. The result is smaller Abbe Errors and less cantilever effects at the expense of a larger footprint. Note that although this structure looks similar to a Gantry configuration, as shown below, the Z Axis is rigidly mounted to a stationary bridge, and the X Axis is mounted to a stationary Base.

Gantry

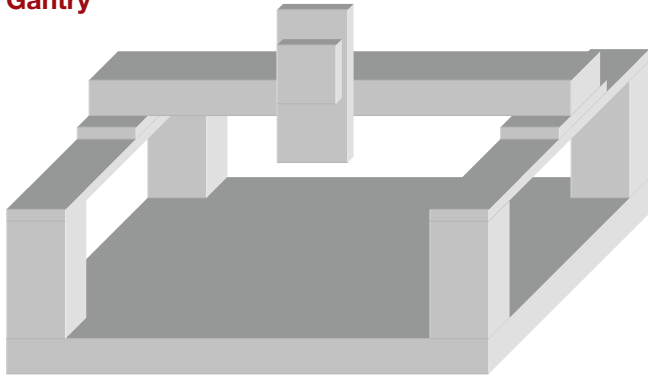

This configuration has the best accessibility to the space around it per footprint of the machine. It is commonly used as single cell or in process application where several machines are operating over a conveyor. Gantry configuration, driven by linear motors and designed for

high natural frequency (typically 150 Hz), can provide an excellent solution that combines high precision, high speed and low settling time. Gantry can further be classified according to the following options:

- Single-sided motor drive typically used for small size applications
- Double-sided motor, driven together by a single amplifier with 1 sided encoder typically used in large system, with low accuracy requirements
- Double-sided motor, driven as two independent axes X1, X2 operating as master slave with two sided encoder typically used for large machines that require high precision. Flexure slides may be needed on the X Axis to prevent cleavage (motion resistance at the bearing of the X Axis due to skewed movement of the Y Axis.)

Loading

Dynamic Loading

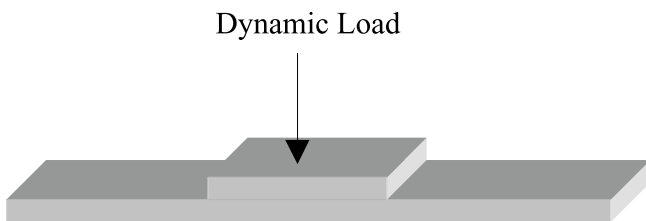

Dynamic loading of a stage is the maximum load that may be applied for a bearing life of 254,000 m (10 Million inches) of travel with no evidence of fatigue appearing in 90% of the bearing. This assumes that the load is constant in magnitude and direction and that all forces are perpendicular to the motion of the stage.

Axial Force (Maximum)

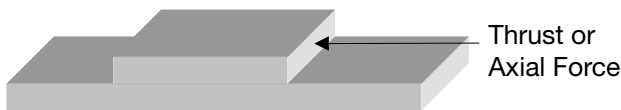

The maximum thrust force that the stage can generate in the direction of travel. This force is used to overcome friction, damping, tool resistance and acceleration.

Moment Loading

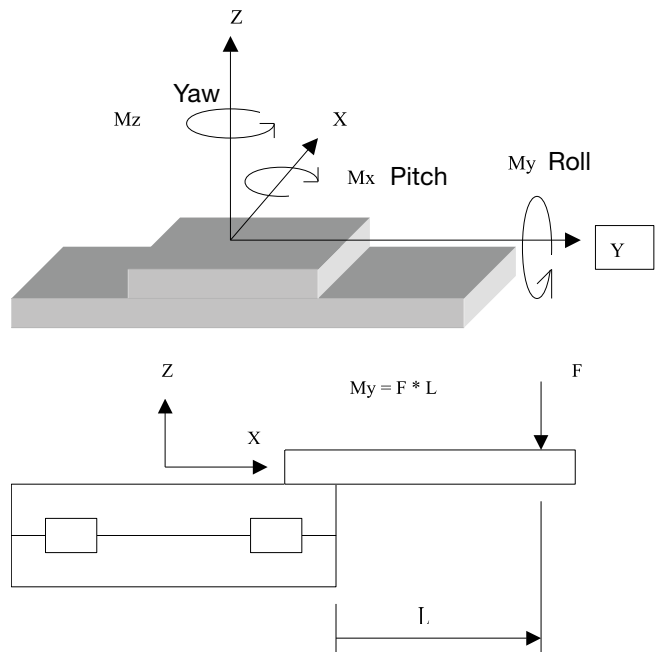

A moment loading defines a twisting load about the bearings. The impact of a moment load is that it is not distributed about all of the bearings uniformly. A moment load can be created in a variety of orientations:

- Mx** When a load is cantilevered off the end of an axis, parallel to the direction of travel
- My** When the load is cantilevered off the sides of an axis, perpendicular to the direction of travel
- Mz** When a force causes a rotational moment about the center of an axis.

Precision

Linear Definitions:

Accuracy

The difference between a commanded position and an actual position of a positioning stage. Accuracy is typically specified in microns that represent specified number of standard deviation “Sigma” (see definition below), per given travel, at a specified height above the stage mounting plate. For example: a +3 micron accuracy, 3 Sigma, per 500 mm travel means that if the controller commands the positioning stage to move to a location 500 mm away from a known “home” position in space, then, in 99.8% of the times that this move will be made, the actual position of the stage, at 25 mm above the mounting surface, will end up being between 499.997 and 500.003 mm.

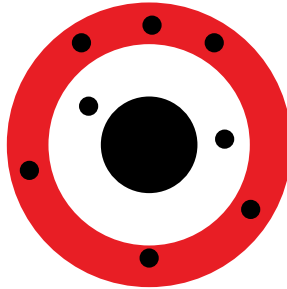

*Low repeatability,
low accuracy*

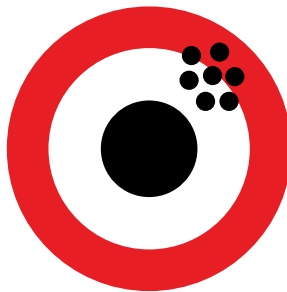

*High repeatability,
low accuracy*

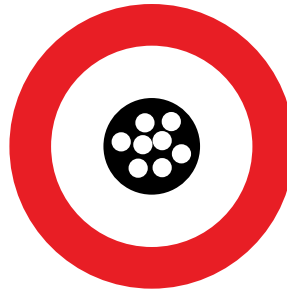

*High repeatability,
high accuracy*

Repeatability

Repeatability represents the maximum deviation between actual position values, obtained in repetitive moves of a positioning stage, to a desired position. Repeatability, like accuracy, corresponds to a specified number of “Sigma”, per specified travel, at a specified height above the mounting surface of the stage.

Resolution (Motion)

The smallest positioning movement that can be achieved by a positioning stage.

Resolution (Encoder)

The smallest increment of the position feedback signal that can be measured by a feedback device (e.g., encoder).

Standard Deviation (Sigma)

The average deviation of a Random Variable (a variable such as position error, whose outcome is of a statistical nature) from its average value (mean). The chart below represents a Standard Normal distribution of a random variable with zero mean and sigma of 1. The X Axis

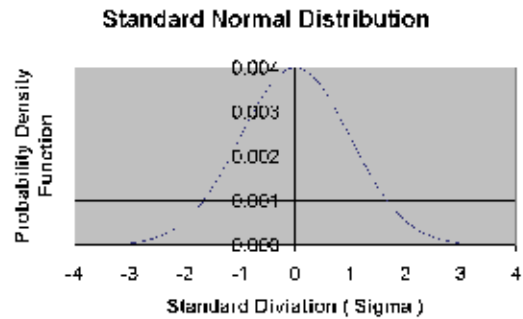

represents the random variable in units of Sigma, and the Y Axis represents the Probability Density function of the random variable. The density function is used to calculate the probability that the random variable will occur between two values on the X Axis. More specifically, the probability of a random variable occurring between two values on the X Axis equals to the area under the Probability Density Function between these two values. The total area under the curve equals 1. Some important areas are as follows: the area between +1 sigma is 0.84, between +2 sigma it is 0.977 and between +3 sigma it is 0.998. This means, for example, that the probability of a random variable occurring between +3 Sigma is 99.8%.

Flatness

The maximum boundaries of positioning path of motion projected on the vertical plane.

Straightness

The maximum boundaries of positioning path of motion projected on a horizontal plane.

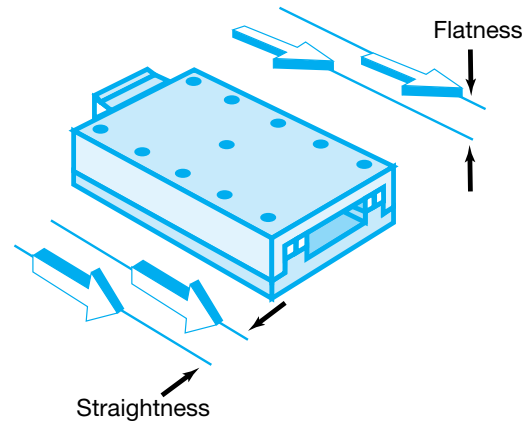

Angular Definitions:

Pitch

An angular deviation possible in positioning systems, in which the table leading edge rises or falls as the table translates along the direction of travel. This represents rotation around a horizontal axis, perpendicular to the axis of travel.

Yaw

An angular deviation from ideal straight line motion, in which the positioning table rotates around the Z (vertical) Axis as it translates along its travel axis.

Roll

An angular deviation from ideal straight line motion, in which the positioning table rotates around its axis of travel as it translates along that axis.

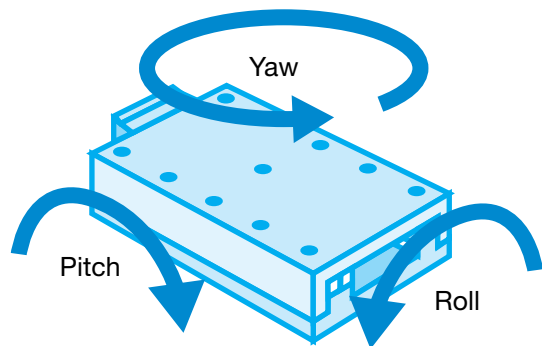

Abbe Error

A linear positioning error caused by a combination of an angular error in the bearing of the positioning stage, and an offset between the bearing and the actual point of interest.

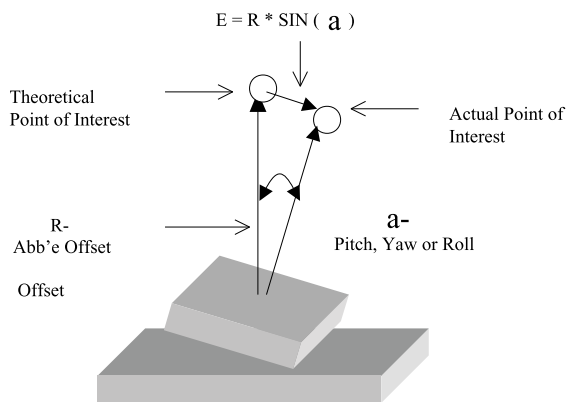

Dynamic:

Constant Velocity

A measure of smoothness of motion of a positioning stage.

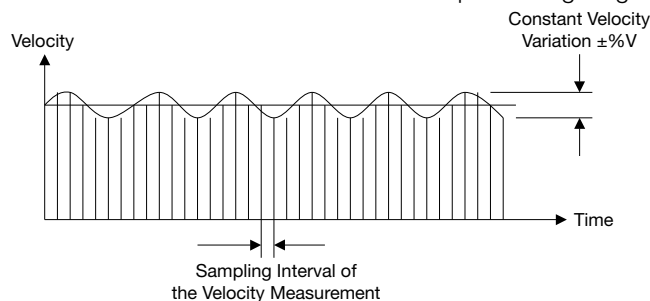

Typically measured in percent variation from a nominal value at a given sampling interval. High smoothness of motion can be achieved by using crossed roller or air bearing stages with ironless linear motors.

Settling Time

The time required for a step response of a system parameter to stop oscillating or ringing and reach its final value. For example, the time it takes for a velocity profile to settle to a specified value of constant velocity after the acceleration ramp phase. Also, the time it takes for a displacement profile to settle to specified accuracy after the deceleration phase at the end of a positioning move. Settling time is greatly affected by the shock, jerk, structural damping and resonance frequencies. Improved settling time in positioning systems can be achieved by high structural stiffness, low moving mass, high natural frequency of the structure, structural damping, high closed loop band width at the overall positioning system and good servo tuning.

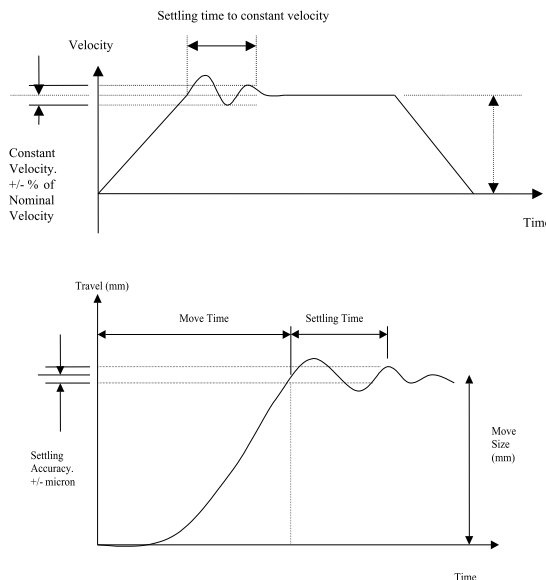

Rotary Positioning Stages

Precision:

Axial Runout Error

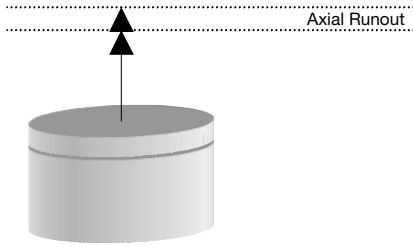

The total indicated reading (TIR) of axis movement along the axis of rotation

Radial Runout Error

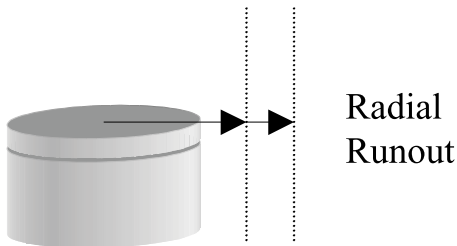

The total indicated reading of the horizontal movement of the rotary table.

Backlash Error

The error in rotational position due to clearance between a worm and a gear as a result of changing direction of motion. Backlash has an effect on two directional repeatability since the motion of worm is lost while reversing direction and traveling through the gap it has with the gear.

Wobble Error

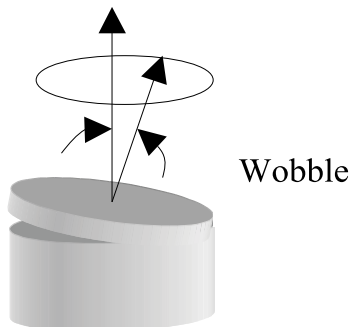

The angular error between the actual axis of rotation and the theoretical axis of rotation.

Loading:

Axial Load Capacity

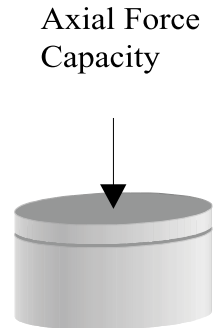

The maximum allowable force acting along the axis of rotation of the rotary stage.

Perpendicular Load Capacity

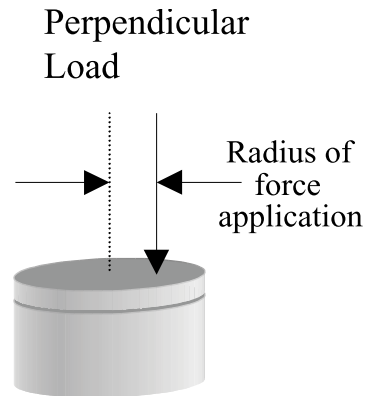

The maximum load perpendicular to the positioning stage top surface, applied at a specified radius from the axis of rotation of the table.

Motion Control Components

Motors

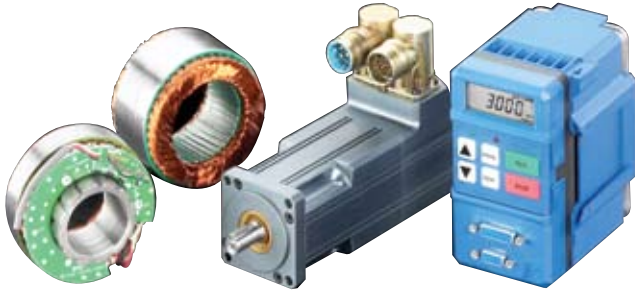

Brushless rotary motor & brushless direct Drive

Linear Motor

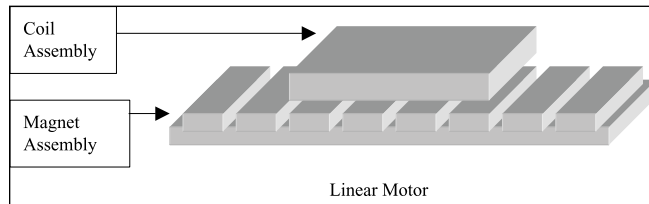

Motors Types Used in Positioning Systems

Servomotor

A device that converts electrical current to mechanical energy where the current is varied by a servo amplifier in a closed loop control system.

DC Motor

A device that converts electrical direct current into mechanical energy. It requires a commutating device, either brushes or electronic. Usually requires source of DC power.

AC Motor

A device that converts electrical alternating current into mechanical energy. Requires no commutation devices such as brushes. Normally operated off commercial AC power. Can be single or multiple phase.

Synchronous Motor

Another term for a Brushless DC motor.

Permanent Magnet Motor

A motor utilizing permanent magnets to produce a magnetic field. Has linear torque/speed or force/speed characteristic.

Brushless Motor

A type of direct current motor that utilizes electronic commutation rather than brushes to transfer current.

Iron Core Linear Motor

A permanent magnet motor consisting of laminated ferrous coil assembly and a single-sided secondary magnet assembly.

Ironless Linear Motor

A permanent magnet motor consisting of a non laminated coil assembly and a U-channel secondary magnet assembly

Piezo Ceramic Motor

A motor made of a small ceramic plate, oscillating at high frequency (e.g. 40Khz), causing its tip to form circular motion. As the tip comes in contact with a longer ceramic plate, attached to the slide of a positioning stage, it applies friction forces on the plate and causes it to move in the direction of the tip circular rotation.

Encoders

An encoder is a position feedback device that converts mechanical motion into electrical signals to indicate actuator actual position. The basic configuration of an encoder can be linear or rotary, incremental or absolute. A rotary encoder is typically attached to the rotary motor and measures the motor shaft rotation. Therefore, any windage effect at the ball screw or lost motion due to backlash and friction will not be seen at the encoder. The linear encoder, on the other hand, reads the actual position closer to the point it takes place and therefore the resulting precision is higher.



Linear Encoder Types Used in Positioning Systems

Absolute Encoder

A digital position transducer in which the output is representative of the absolute position of the input shaft within one (or more) revolutions. Output is usually a parallel digital word.

Incremental Encoder

A position transducer in which the output represents incremental changes in position.

Linear Encoder

A digital position transducer that directly measures linear position.

Quadrature Encoder

This is a special incremental encoder with two channels A and B, sometimes referred to as A Quad B. The two channels are 90 degrees out of phase. This configuration allows detection of direction as well as increasing the resolution by a factor of four.

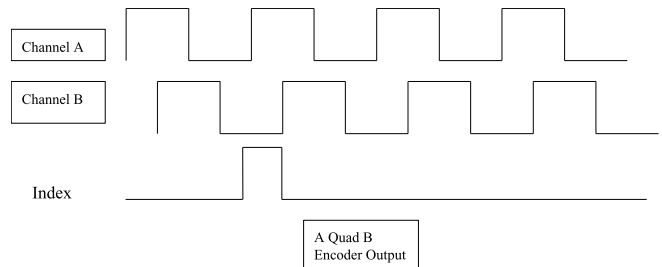

Controller/Amplifier/Motion Controllers

A motion controller is an electronic device that communicates with a host computer and has the capability to store a desired motion profile as a function of time or any other reference signal, read the actual position feedback, calculate the error, and send out a command signal to the servo amplifier as a complex function of the error and its derivatives. It can also monitor various I/O signals and control several axes in a coordinated moves.

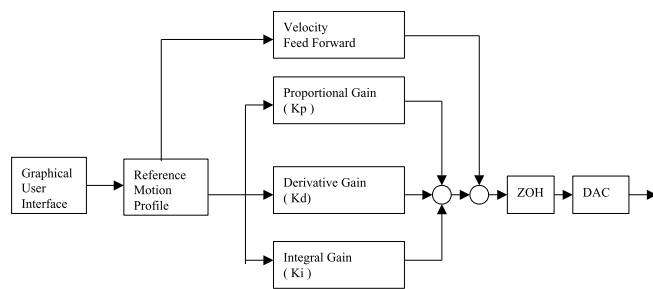

PID controller block diagram with Feed Forward and ZOH

PID Controller Functional Elements

ZOH

Zero Order Hold represents the controller time delay in processing the input signals before the output to the amplifier is updated.

DAC

Digital to Analog Converter component that receives a digital signal from the controller filter and outputs an Analog signal to the Amplifier.

Compensation

The corrective or control action in a feedback loop system that is used to improve system performance characteristics such as accuracy and response time.

Compensation, Feed forward

A control action that depends on the command only and not the error to improve system response time.

Compensation, Integral

A control action that is proportional to the integral or accumulative time error value product of the feedback loop error signal. It is usually used to reduce static error.

Compensation, Lag

A control action that causes the lag at low frequencies and tends to increase the delay between the input and output of a system while decreasing static error.

Compensation, Lead

A control action that causes the phase to lead at high frequencies and tends to decrease the delay between the input and output of a system.

Compensation, Lead Lag

A control action that combines the characteristics of lead and lag compensations.

Compensation, Proportional

A control action that is directly proportional to the error signal of a feedback loop. It is used to improve system accuracy and response time.

Compensation, Derivative

A control action that is directly proportional to the rate of change of the error signal of the feedback loop. It is used to improve system damping to provide smooth motion and reduce settling time.

Servo Amplifier



Servo Amplifier Functional Elements

Servo Amplifier

An Amplifier that utilizes internal servo feedback loops for accurate control of motor current and or velocity.

Analog Amplifier

An Amplifier that has an analog signal as an input.

Digital Amplifier

An Amplifier in which tuning and parameter setting is done digitally. Input can be an analog or digital signal.

Linear Amplifier

An Amplifier that has output directly proportional to either voltage or current input. Normally both input and output signals are analog.

PWM Amplifier

An Amplifier utilizing Pulse Width Modulation techniques to control power to the motor. Typically a high-efficiency drive that can be used for high response applications.

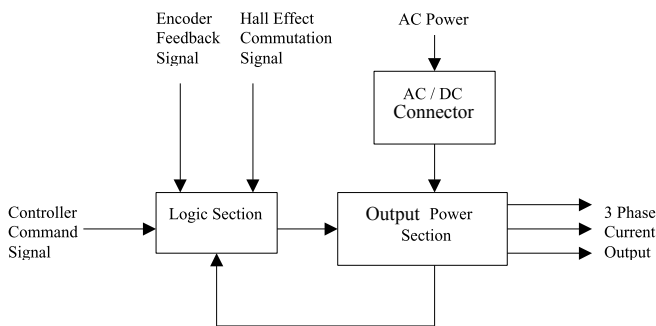

Actuator Sizing and Selection

① Thrust Calculation

Calculate the thrust generated by the application. Total thrust generally consists of three components:

$$\text{Acceleration Thrust } F_a = L/g \times V/T_a$$

$$\text{Thrust Due to Gravity* } F_g = L \sin \alpha$$

$$\text{Thrust Due to Friction } F_f = \mu_s L \cos \alpha$$

$$\text{Total Thrust} = F_t = F_a + F_g + F_f$$

*Horizontal applications do not apply.

Terms used:

- F_t = Total (maximum) thrust force (N, lb)
- F_f = Friction force (N, lb)
- F_g = Force of gravity (N, lb)
- α = Angle of inclination (see illustration below)
- μ_s = Coefficient of Sliding Friction (Load friction only, actuator friction excluded)
- L = Actual load (N, lb)
- g = Acceleration due to gravity (9800 mm/sec², 386 in/sec²)
- V = Velocity (mm/sec, in/sec)
- T_a = Acceleration time (sec)
- D = Move distance (mm, in)
- t = Move time (sec)
- A = Acceleration (mm/sec², in/sec²)

Actuator Orientation

The terms used and their values depend upon the orientation of the actuator. Refer to the illustrations and equations below to determine the form of the thrust equation.

Horizontal



Horizontal Equations:

$$F_t = F_a + F_f$$

Vertical

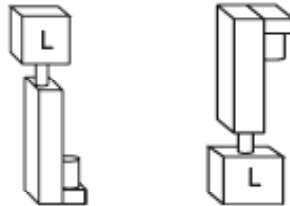

Vertical Equations:

$$\text{Upward: } F_t = F_a + F_g + F_f$$

$$\text{Downward: } F_t = F_a - F_g + F_f$$

Angular

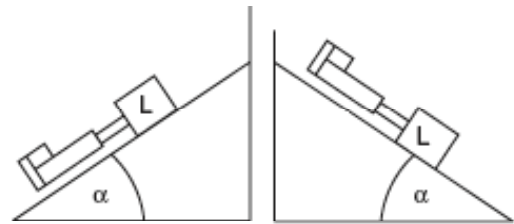

Angular Equations:

$$\text{Upward: } F_t = F_a + F_g + F_f$$

$$\text{Downward: } F_t = F_a + F_g + F_f$$

② Motion Profile Calculations

Two common motion profiles that relate velocity to time are the Trapezoidal and Triangular motion profiles. They serve as good starting points for calculating motion parameters and thrusts.

Determine the required velocities and accelerations for the application.

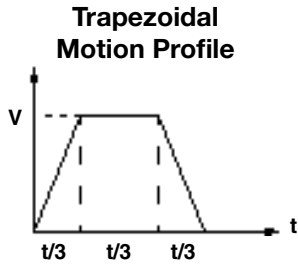

$$V = 1.5 \times D/t$$

$$A = 4.5 \times D/t^2$$

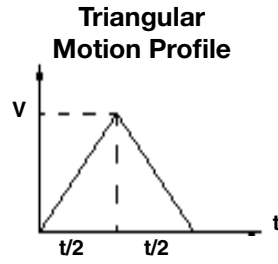

$$V = 2 \times D/t$$

$$A = 4 \times D/t^2$$

Acceleration $\leq 1 \text{ g}$ (9.8 m/sec²)

Note on Acceleration: In general, any acceleration less than or equal to 1 g (9.8 m/sec² or 386 in/sec²) is considered acceptable. Accelerations greater than 1 g should be referred to the factory before ordering.

③ Determine Motor Torque Requirements

Maximum Torque

$$T = \frac{\text{Thrust} \times \text{Lead}}{\eta_s \times \eta_b \times 2\pi \times \text{Ratio}}$$

Where:

Lead = Screw Lead (in/Rev)

Thrust = Calculated thrust value in N (lbf)

$$= F_a + F_g + F_f$$

F_a (acceleration thrust)

$$= \text{Load}/(9800 \text{ mm/sec}^2) \times \text{Velocity}/\text{acceleration time}$$

F_g (force of gravity) = Load $\times \sin\alpha$

F_f (friction force) = μ_s (see table) \times Load $\times \cos\alpha$

η_b = Timing belt efficiency:

for parallel driven versions (typically 0.9 or 90%)
for in-line versions, use 1.

η_s = Screw efficiency (see table)

Belt drive efficiencies = 0.9

T = Input torque required, Nm (in-lb)

Ratio = Drive ratio (if timing belt is not 1:1 or another reducer is used)

Friction Coefficient

Material (dry contact unless noted)	μ_s
Steel on steel	0.80
Steel on steel (lubricated)	0.16
Aluminum on steel	0.45
Copper on steel	0.22
Brass on steel	0.35
Teflon on steel	0.04

④ Continuous Torque (Servo systems only)

With servo motors, it is important to understand the relationship between peak torque and continuous torque. Continuous or rms torque refers to the torque a servo motor system can produce continuously, or at 100% duty cycle. Peak torque refers to torque produced in intermittent time quantities, generally less than 5 seconds. This allows the user to better size the servo motor required based on what the actual torque needs are for the application. The maximum torque calculated in the previous section will represent the peak torque requirement. To determine the continuous torque requirement, first establish a sequence of use over a given duty cycle.

It is necessary to calculate the torque required at different instances of thrust. There are three general types of torque, and they correspond to thrusts calculated earlier:

Acceleration Torque

Torque when generating total thrust F_t (This is normally the maximum torque required.)

Constant Speed Torque

Torque when generating friction and gravity thrust ($F_f + F_g$)

Static Torque

Torque when holding a static load (typically gravity thrust F_g)

To calculate the continuous (rms) torque:

$$T_{rms} = \sqrt{[\sum T_i^2 t_i / \sum t_i]}$$

Where:

- T_i = Torque required over time interval t_i (Nm, in-lb)
- t_i = Time interval i (sec)

Example: For a typical trapezoidal profile, let

- T_1 = acceleration torque = 1000 Nm
- t_1 = 1 sec
- T_2 = torque at a constant speed (friction) = 25 Nm
- t_2 = 1 sec
- T_3 = deceleration torque = 1000-25 = 975 Nm
- t_3 = 1 sec
- T_4 = torque at rest = 0 Nm (horizontal orientation)
- t_4 = 10 sec

When viewing servo motor speed-torque curves, let T_{rms} represent the maximum continuous torque value, while T_{max} may represent the peak torque value. Stepper motors run constantly at full torque and consequently require only the maximum torque value for sizing and selection.

Terms used:

- Lead = Screw lead (in/Rev)
- V_L = Maximum linear velocity in m/s (in/sec)
- Ratio = Reduction ratio, if any (i.e. 2:1, Ratio =)
- Speed = Required motor speed in rev/sec

This would represent a single duty cycle.
To calculate T_{rms} .

$$T_{rms} = \sqrt{[(1000 \text{ Nm})^2 \times 1 \text{ sec}] + [(25 \text{ Nm})^2 \times 1 \text{ sec}] + [(975 \text{ Nm})^2 \times 1 \text{ sec}] + [(0 \text{ Nm})^2 \times 10 \text{ sec}] / [1 + 1 + 1 + 10 \text{ sec}]}$$

$T_{rms} = 387.42 \text{ Nm}$

Breakaway Torque

This information should be taken into consideration when selecting an appropriate motor to drive the actuator and load. The breakaway torque will factor into the initial peak torque required to accelerate the mass from rest.

Before each actuator ships, it is tested for breakaway and running torques. The report generated is shipped with the maintenance manual and other paperwork included with the actuator. This allows a customer to view the specific details of the custom actuator ordered.

Calculating Smallest Linear Resolution

First find the number of steps required to produce breakaway torque:

$$X = \frac{T_b}{\sin(M_{res}/D_{res}) \times T_s}$$

Where:

- X = Steps required to produce breakaway torque
- T_b = Breakaway Torque
- T_s = Motor Static Torque
- M_{res} = Motor resolution in electrical degrees per rev (18,000 electrical deg/rev)
- D_{res} = Drive resolution in steps per rev

Then calculate resolution:

$$\text{Resolution} = (\text{screw lead} / \text{drive resolution}) \times X$$

Determine the maximum speed required

$$\text{Speed} = \frac{VL \times \text{Ratio}}{\text{Lead}}$$

Where:

- Lead = Screw lead (in/rev), see page 128
- VL = Maximum linear velocity in m/s (in/sec)
- Ratio = Reduction ratio, if any (i.e. 2:1, Ratio = 2)
- Speed = Required motor speed in rev/sec

Calculate the total inertia of the system

$$I_{total} = I_{mass} + I_{drive}$$

Where:

- I_{total} = Total inertia of system (excluding motor inertia), kg-m² (oz-in²)
- I_{mass} = Inertia of mass in kg-m² (oz-in²)
Metric: $I_{mass} = M \times [\text{Lead} / (2\pi \times 1000)]^2$
English: $I_{mass} = W \times (\text{Lead} / 2\pi)^2$
- M = Load mass (kg) for metric calculation
- W = Load weight (lb) for English calculation
- Lead = Screw lead (m/rev, in/rev)
- I_{drive} = Inertia of the actuator drive train (see tables)

Is a reducer being included in the system?

To calculate the reflected inertia to the motor, divide the inertia of the mass and drive pulley by the square of the reduction ratio. Add the inertia of the reducer to the total inertia.

$$I_{total} = \frac{I_{reducer} + (I_{mass} + I_{drive})}{R^2}$$

Where:

- R = Reduction ratio (i.e., 3:1 ratio, R = 3)

Load and Cylinder Orientation

Refer to actuator series for "δ" values.

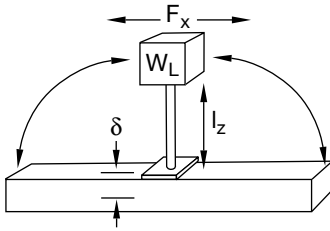

$$F_n = F_z = W_L$$

$$M_y = F_x (l_z + \delta)$$

$$F_x = \text{Thrust}$$

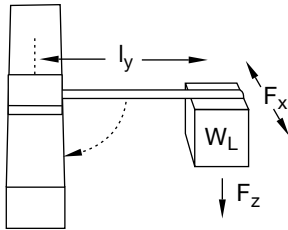

$$F_n = F_z = W_L$$

$$M_y = F_x (l_z + \delta)$$

$$M_x = F_z (l_y)$$

$$M_z = F_x (l_y)$$

$$F_x = \text{Thrust}$$

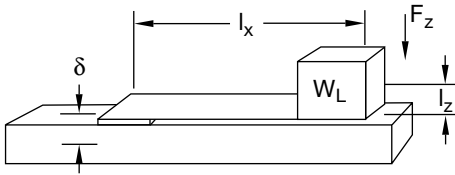

$$F_n = F_z = W_L$$

$$M_y = F_z (l_x) + F_x (l_z + \delta)$$

$$F_x = \text{Thrust}$$

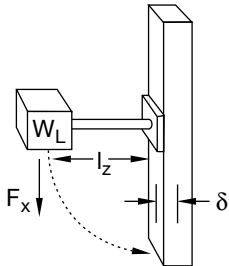

$$M_y = F_x (l_z + \delta)$$

$$F_x = \text{Thrust}$$

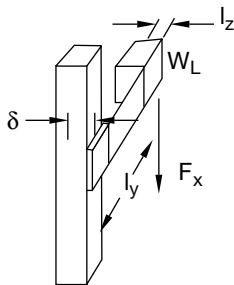

$$M_y = F_x (l_z + \delta)$$

$$M_z = F_x (l_y)$$

$$F_x = \text{Thrust}$$

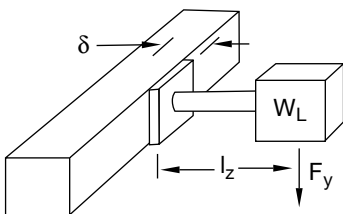

$$F_y = W_L$$

$$M_y = F_x (l_z + \delta)$$

$$M_x = F_y (l_z + \delta)$$

$$F_x = \text{Thrust}$$

Recirculating Bearing Tables Calculations

The useful life of any linear translation table at full catalog specifications is dependent upon the forces acting on its bearing system. These forces include both static components, due to load weight, as well as dynamic components due to accelerations and decelerations of the load required by the motion profile. In multi-axes applications, the load capacity is usually limited by the positioner at the bottom of the stack. In the load/life calculations, it is critical to include the weight of all positioning elements in the total load carried by this lowest table.

The following formulas and examples illustrate the calculation of the forces acting on each bearing block. The service life and suitability of a positioner for a given application are determined by vectorial forces on the critically loaded bearing element.

Several dimensions, which are specific to each linear positioning table model, and the load geometry are required for these computations. These dimensions are supplied in the catalog information for each positioner. The dimensions are referenced as follows:

d1 = bearing block center-to-center longitudinal spacing

d2 = bearing rail center-to-center lateral spacing

da = rail center-to-carriage mounting surface

General Limitations

Linear positioning tables are rated at catalog specifications for performance with a maximum load to provide 100 million inches of travel life. *While loads greater than this maximum may be supported, Daedal cannot generally guarantee the accuracy, durability or safety of an overloaded positioner. Please contact Daedal applications engineering for assistance with highly loaded applications.*

Horizontal Translation with Normal Load

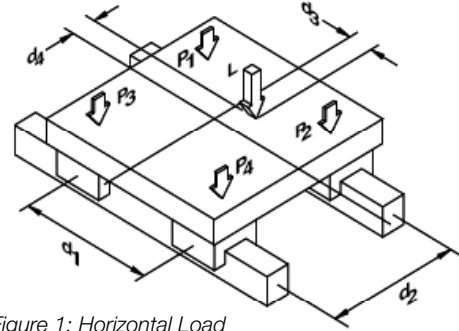

Figure 1: Horizontal Load

Figure 1 shows a normal load applied to the carriage translating horizontally. The vector L, defined by the CG of the load, is shown applied at a point whose coordinate distances from the center of the carriage are given by distances d3 and d4.

With the positioner at rest or moving with uniform velocity, the loads on each of the four bearing blocks are given by the following equations:

$$P_1 = \frac{L}{4} - \left[\frac{L}{2} \cdot \frac{d_3}{d_1} \right] + \left[\frac{L}{2} \cdot \frac{d_4}{d_2} \right]$$

$$P_2 = \frac{L}{4} + \left[\frac{L}{2} \cdot \frac{d_3}{d_1} \right] + \left[\frac{L}{2} \cdot \frac{d_4}{d_2} \right]$$

$$P_3 = \frac{L}{4} - \left[\frac{L}{2} \cdot \frac{d_3}{d_1} \right] - \left[\frac{L}{2} \cdot \frac{d_4}{d_2} \right]$$

$$P_4 = \frac{L}{4} + \left[\frac{L}{2} \cdot \frac{d_3}{d_1} \right] - \left[\frac{L}{2} \cdot \frac{d_4}{d_2} \right]$$

Note that each of the four bearing blocks will experience either compressional or tensional loading; the magnitude of these forces at each bearing is dependent upon the location of the load vector with respect to the center of the positioner carriage. For each bearing, the maximum of the forces in tension and compression is plotted on the load charts for the specific model positioner to determine the life of the table in the application.

The calculations for loads whose CG falls outside the carriage mounting surface area, as shown in Figure 2, are identical to those used with Figure 1. In either case, accelerations and decelerations of the load must be considered in calculating the dynamic forces which determine the life of the system in a particular application.

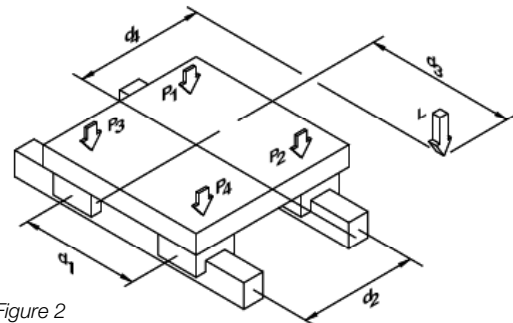

Figure 2

Horizontal Translation with Side Load

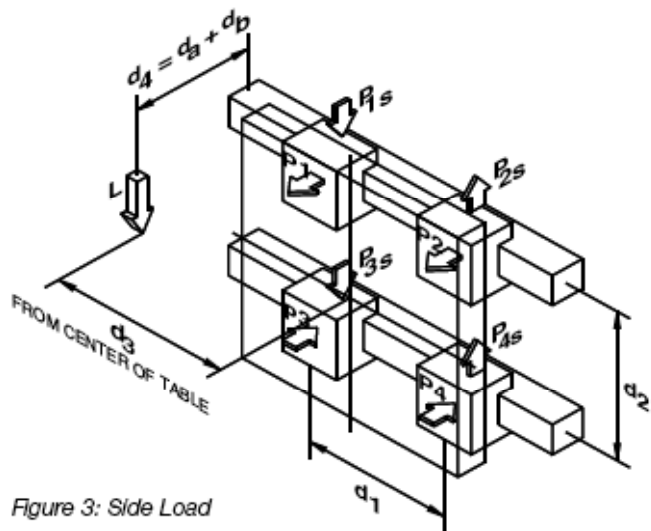

Figure 3: Side Load

Consider a positioner as shown in Figure 3, which involves a lateral (side) load applied to the carriage which translates horizontally. The load vector (L) is shown applied at a point whose coordinate distances from the center of the carriage bearing system are given by dimensions d3 and d4. Note that d4 is the sum of distance da—the distance between bearing and center and carriage surface which is provided for each linear positioner—plus db, the distance of the load CG from the mounting surface of the carriage.

The loading felt by each of the four bearing blocks when the positioner is stationary or moving with uniform velocity is given by the following equations:

$$P_1 = P_2 = \frac{L}{2} \left[\frac{d_4}{d_2} \right]$$

$$P_3 = P_4 = - \frac{L}{2} \left[\frac{d_4}{d_2} \right]$$

$$P_{1s} = P_{3s} = \frac{L}{4} + \left[\frac{L}{2} * \frac{d_3}{d_1} \right]$$

$$P_{2s} = P_{4s} = \frac{L}{4} - \left[\frac{L}{2} * \frac{d_3}{d_1} \right]$$

Here P1, P2, P3 and P4 are the normal loads (tensional and compressional) and P1S, P2S, P3S and P4S are the side loads. For each bearing, the largest side loads and normal loads in both tension and compression are identified for calculating the positioner life in the application.

For round rail/ball bushing type bearings, the forces are plotted individually on the appropriate curves to determine the service life.

For linear motion guide bearing positioners, an “equivalent load per bearing” is calculated for the life determination.

Vertical Translation

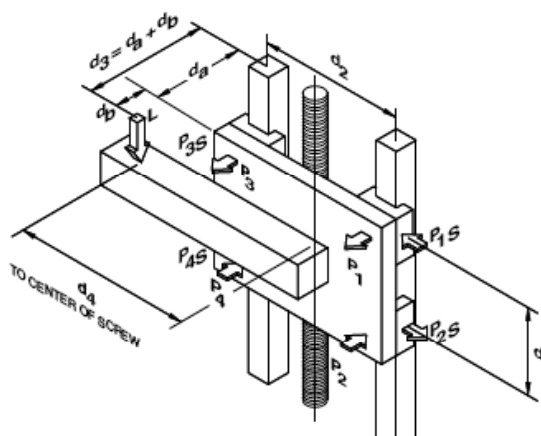

The figure above shows a load applied to the positioner carriage which translates vertically. The load vector (L) is shown applied at a point whose coordinate distances from the center of the carriage bearing system are given by distances d3 and d4. Note that here d3 is the sum of distance da, which is given for the particular linear positioner plus db, the distance of the load CG from the mounting surface of the carriage. d4 is the horizontal distance of the load vector (L) from the carriage center-line.

The loading felt by each of the four bearing blocks when the positioner is stationary or moving with uniform velocity is given by the following equations:

$$P_1 = P_3 = \frac{L}{2} \left[\frac{d_3}{d_1} \right]$$

$$P_2 = P_4 = - \frac{L}{2} \left[\frac{d_3}{d_1} \right]$$

$$P_{1s} = P_{3s} = \frac{L}{2} \left[\frac{d_4}{d_2} \right]$$

$$P_{2s} = P_{4s} = - \frac{L}{2} \left[\frac{d_4}{d_2} \right]$$

P1 through P4 and P1S through P4S are respectively the normal and side loads on each bearing block. For each bearing, the largest side loads and normal loads in both tension and compression are determined and, for linear motion guides, “equivalent loads” are computed from the equations in Table A (page B14) following the same procedure described in the preceding section for Horizontal Translation with Side Load to calculate the positioner life in the applications.

Once more, accelerations and decelerations of the load must be considered in calculating the dynamic forces which determine the life of the system in a particular application.

Calculate Life Expectancy

As with all mechanical components, the life expectancy of the screw driven actuators is influenced by many factors, including loads, speeds, lubrication, temperature, and mounting.

Measurement of Usable Life:

Ballscrew

Usable life is the length of travel that 90% of a group of ball bearing screws will complete or exceed before metal fatigue develops. Fatigue is from the flexing of metal as the balls pass over a given point under load. This is in evidence when "rough spots" or "drag" (points of excessive friction) begin to appear along the travel of the actuator.

Note: Predicting the life of a ball screw is done in the same manner as the bearing industry rates ball bearings, by its B_{10} life. The B_{10} life means that 10% of the units could fail before reaching the required travel (at max rated load) and that 50% of the units will exceed 5 times the rated travel.

Belt Drive Life Expectancy

Parker EMN specifies the loading capacity of the HPLA and HLE units to 15,000 hours of operation. Specifying for this life would equate to operating in motion for 10 hours per day, 250 days per year, for 6 years continuously. For information on sizing and selecting our belt driven products please refer to parkeremotion.com and download DimAxes sizing software.

To Use Charts in Each Section: (Ballscrew actuators only)

1. Determine required life (in millions of millimeters or inches of travel). Life is determined by multiplying the total stroke in inches or mm by the total number of strokes required for the designed life of the equipment.

$$L_m = \sqrt{\frac{\%_1(L_1)^2 + \%_2(L_2)^2 + \%_3(L_3)^2 + \%_n(L_n)^2}{100}}$$

Where

L_m = equivalent load

L_n = each increment of load

$\%_n$ = percent of stroke at load L_n

For Example:

$L_1 = 150\# \quad \%_1 = 30\%$

$L_2 = 225\# \quad \%_2 = 45\%$

$L_3 = 725\# \quad \%_3 = 25\%$

$$L_m = \sqrt{\frac{30(150)^2 + 45(225)^2 + 25(725)^2}{100}}$$

$L_m = 466 \text{ lbs.}$

2. Calculate the equivalent load L_m
3. Find the point at which load and life intersect.
4. Select actuator screw combination to the right of or above the point of intersection.

Positioning System Analysis

System Modeling

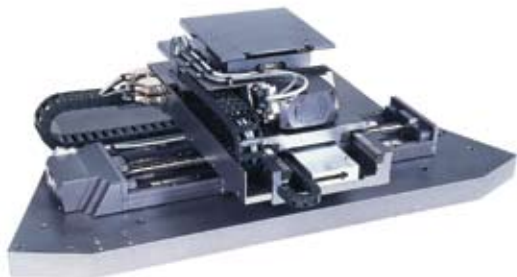

Physical Model

System modeling is important for developing a better understanding of the effects that various design variables, operating conditions and selected motion control components have on the overall positioning system performance. Modeling starts with a physical system to be modeled. For example, the picture shows a positioning system in a compound X,Y,Z configuration. In the following sections we will model and analyze a typical axis of similar machines.

Schematic Diagram

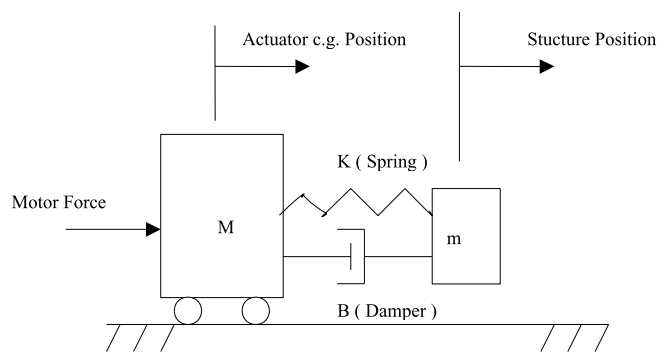

Once the physical model is defined, a schematic diagram shows the main mechanical components, which are included in the theoretical model, and the way they interact. The diagram shows for example a model of a positioning stage with mass M, driven by a motor force and carrying a flexible structure with mass m, stiffness K and Damping B. The schematic diagram is then used for writing the equations of motion of the theoretical model.

Block Diagram & Transfer Functions

(See the next section on Frequency Response for Parameter definitions.)

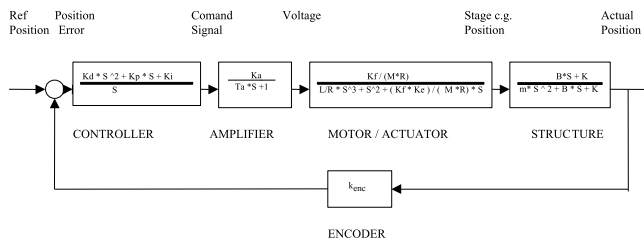

The block diagram represents the motion control process within the system with all of its modeled components. The arrows represent the flow of signals within the system from one component to another. The block themselves contain expressions that are called Transfer Functions. Transfer Functions include operators (e.g., “S” designating differentiation and “1/S” designating Integration) and parameters that together describe the equations of motion of each block, which relate the output variable of a block to its input variable. Transfer functions are used to determine the ratio between the magnitude of the output variable to the magnitude of the input variable. This ratio is called “gain” and it is measured in units of dB, where dB is defined as 20* Log (output / Input). Furthermore, Transfer Functions are used to calculate the “phase angle” which is the lag or lead of the output signal versus the input signal measured in degrees. The plot that shows the gain and the phase angle as a function of input frequency is called “Bode Plot”.

Frequency Response

The purpose of Frequency Response Analysis, as shown below, is to help in understanding the motion characteristic of each component in the positioning system, as well as the characteristics of the system as a whole. The plots display the “gain” in units of db, ($20 \cdot \log(\text{output} / \text{input})$) and “phase angle” in degrees for each block in the Block Diagram. Both plots are shown as a function of the frequency of the input variable and referred to as Bode Plots. The frequency in the plots is displayed in logarithmic scale. For example 1 represents 10^1 rad/sec, 2 represents $10^2 = 100$ rad/sec, etc. The analysis is important in determining the Closed Loop Bandwidth of the system, as well as its stability.

Components

Controller - PID

The PID transfer function, has the “positioning error” signal as an input and the “Controller command” signal to the amplifier as an output. It shows high gain (ratio of output signal to input signal) in low frequencies, acting as a low pass filter. It also has high gain at high frequencies, acting as a high pass filter. And finally it has lower gain in some intermediate frequencies, reducing the effects of various vibration causes such as structural resonance, bearing jitter, cogging, and tool vibrations. The low pass filter, caused by the integrator term, K_i , amplifies small errors, such as those caused by friction, and reduces them over time. The high-pass filter, caused by the derivative gain, K_d , allows the system to lead its reaction to high frequency errors. The phase angle of the output signal versus the input signal starts at -90 degrees Lag and ends up at 90 degrees lead. The purpose of the PID transfer function is to shape the overall transfer function of the positioning system, by choosing the right set of PID parameters, K_p , K_i , K_d , to obtain a fast responding, stable, system with high closed-loop bandwidth.

Servo Amplifier

PID Frequency Response

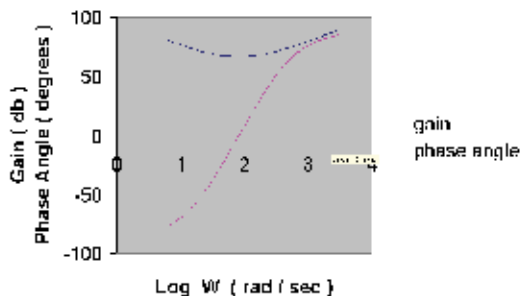

The amplifier transfer function, has “controller command” signal as an input and “motor voltage” as an output. As shown, the output signal follows the input signal at low frequencies with a constant gain, as determined by the parameter, K_a , of the amplifier. At a certain frequency, called the cutoff frequency, the gain starts to attenuate as frequency increases. The phase angle shows zero lag until the frequency reached the cutoff value, then the output starts to lag to a maximum of -90 degrees at very high frequencies. The cutoff frequency is the inverse of the amplifier time constant T_a , as shown in the transfer function. A time constant is the time it takes for the output signal to reach the level of 63% of a step in the input signal.

Motor/Stage

The combined Motor/Stage transfer function, has “motor voltage” as an input and “stage position” as an output. The

Amplifier Frequency Response

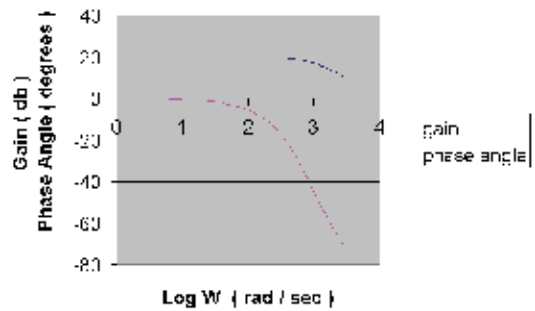

gain shows a characteristic of reducing magnitude at a rate of 20 db/decade (decade is a multiple of 10 in frequency change) until a resonant frequency is reached. Then the gain attenuation becomes steeper and reduces at a rate of 60 db/decade. The phase angle starts out at a -90 degrees until the resonance frequency and then it drops an additional 180 degrees to a total of -270. The transfer function of this block has two time constants. One is the electrical time constant of the motor (L/R) and the other is the mechanical time constant of the stage ($M \cdot R / K_f \cdot K_E$). Where,

- L = Motor Coil Inductance
- R = Motor Coil Resistance
- K_f = Motor Force Constant
- K_E = Motor Back EMF
- M = Stage Moving Weight

Structure

Motor / Stage Frequency Response

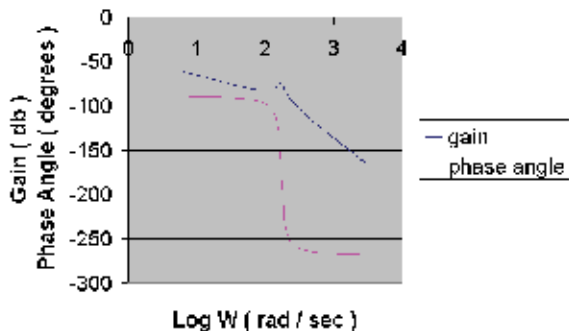

Complete System

Structure Frequency response

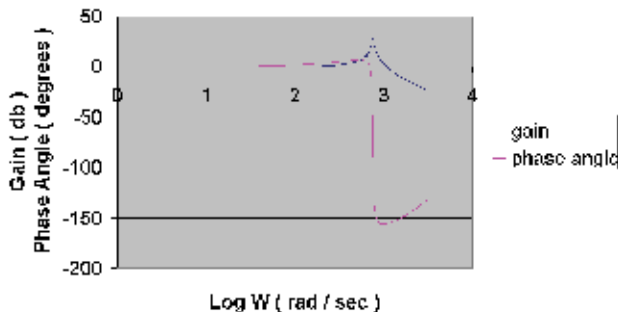

The structure transfer function, has the “stage position” as an input and the actual “structure position” of a point of interest on the structure (e.g. Encoder location) as the output. This is a classical transfer function of a mass, spring, damper system with a positive position excitation of the base.

The gain starts at 1 (zero dB) with low frequencies and gradually increases and reaches a peak at the natural frequency of the structure. Then the gain drops at a rate of 40 dB / decade at higher frequencies. The phase angle starts out as zero, at low frequency, and drops 180 degrees around the natural frequency. Finally it gains additional 90 degrees to a total of -90 degrees at very high frequencies. The parameters that characterize this system are as follows:

- m- Structural Mass
- K- Structural Stiffness
- B- Structural Damping

Where the natural frequency of the structure $\omega_n = \sqrt{K/m}$

Overall Positioning System Bode Plot

The overall transfer function of the positioning system model, as shown in the Bode Plot, is made as the superposition of all transfer functions of the individual components. The most important features of this plot are the closed loop bandwidth of the system and the two stability criteria: Phase Margin and Gain Margin. The closed loop bandwidth is determined by the frequency where the gain of the overall transfer function (known as open loop transfer function) crosses the 0 dB line, also referred to as a cross over frequency. The difference between the phase angle at the cross over frequency and -180 degrees is called Phase Margin. For a stable system the Phase margin must be greater than zero. The difference between the gain of zero db and the gain at -180 degrees is called the Gain Margin. For a stable system the gain margin must be greater than zero. The closed loop bandwidth in the example at the chart is about 48 Hz (300 rad/sec, between 102 and 103 in the chart). The phase margin is about 30 degrees and the gain margin is a few dB, indicating a marginally stable system. The signatures of the PID, Motor/ Amplifier and structure are clearly noticeable in the overall plot.

Complete System Frequency Response

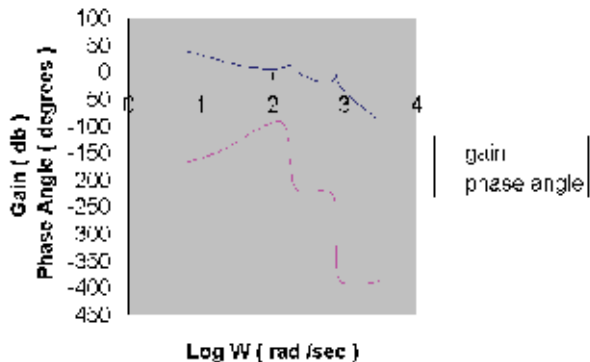

Glossary of Terms

Absolute Positioning: Refers to a motion control system employing position feedback devices (absolute encoders) to maintain a given mechanical location.

Accuracy: The difference between the expected The maximum deviation between a commanded position and an actual position of a positioning stage. Accuracy is typically specified for + 3 sigma deviation per given travel.

Actuator: A device which creates mechanical motion by converting various forms of energy to mechanical energy.

Adaptive Control: A technique to allow the control to automatically compensate for changes in system parameters such as load variations.

Abbe Error: A linear positioning error caused by a combination of an angular error in the ways, and an offset between the precision determining element (lead screw, feedback device, etc.) and the actual point of interest.

Ambient Temperature: The temperature of the cooling medium, usually air, immediately surrounding the device such as a motor.

Amplifier: Electronics which convert low level command signals to high power voltages and currents to operate a servomotor.

Back EMF: The electromagnetic force (voltage) generated as coil windings move through the magnetic field of the permanent magnets in a brushless servomotor. This voltage is proportional to motor speed and is present regardless of whether the motor windings are energized or de-energized.

Closed Loop: A broadly applied term relating to any system where the output is measured and compared to the input. The output is then adjusted to reach the desired condition. In motion control the term is used to describe a system wherein a velocity or position (or both) transducer is used to generate correction signals by comparison to desired parameters.

Coefficient of Friction: This is defined as the ratio of the force required to move a given load to the magnitude of that load. Typical values for the ball and crossed roller slides are 0.001 to 0.005.

Cogging: A term used to describe non-uniform angular velocity. Cogging appears as jerkiness especially at low speeds.

Command Position: The desired angular or linear position of an actuator.

Commutation: A term which refers to the action of steering currents or voltage to the proper motor phases so as to produce optimum motor torque. In brush type motors, commutation is done electromechanically via brushes and commutator. In brushless motors, commutation is done by the switching electronics using rotor position information typically obtained by hall sensors, a resolver or an encoder.

Compliance: The amount of displacement per unit of applied force.

Coordinated Motion: Multi-axis motion where the position of each axis is dependent on the other axis such that the path and velocity of a move can be accurately controlled (requires coordination between axes).

Damping: An indication of the rate of decay of a signal to its steady state value.

Dead Band: A range of input signals for which there is no system response.

Detent Torque: The maximum torque that can be applied to an de-energized stepping motor without causing continuous rotating motion.

Duty Cycle: For a repetitive cycle, the ratio of on time to total cycle time: $\text{Duty Cycle} = \text{On Time} / (\text{On Time} + \text{Off Time}) \times 100\%$

Dynamic Braking: A passive technique for stopping a permanent magnet brush or brushless motor. The motor windings are shorted together through a resistor which results in motor braking with an exponential decrease in speed.

Efficiency: The ratio of output power to input power.

Explosion-proof: A motor classification that indicates a motor is capable of withstanding internal explosions without bursting or allowing ignition to reach beyond the confines of the motor frame.

Flatness of Travel: Deviation from ideal straight line travel in a vertical plane, also referred to as vertical runout.

Following Error: The positional error during motion resulting from use of a position control loop with proportional gain only.

Friction: A resistance to motion caused by surfaces rubbing together. Friction can be constant with varying speed (coulomb friction) or proportional to speed (viscous friction) or present at rest (static friction).

Hall Sensors: A feedback device which is used in a brushless servo system to provide information for the amplifier to electronically commutate the motor. The device uses a magnetized wheel and hall-effect sensors to generate the commutation signals.

Holding Torque: Sometimes called static torque, it specifies the maximum external force or torque that can be applied to a stopped, energized motor without causing the rotor to rotate continuously.

Home Position: A reference position for all absolute positioning movements. Usually defined by a home limit switch and/or encoder marker. Normally set at power up and retained for as long as the control system is operational.

Horsepower (HP): One horsepower is equal to 746 watts. Since $\text{Power} = \text{Torque} \times \text{Speed}$, horsepower is a measure of a motor's torque and speed capability (e.g. a 1 HP motor will produce 35 in-lb. at 1,800 RPM).

Hunting: The oscillation of the system response about a theoretical steady-state value.

Incremental Motion: A motion control term that is used to describe a device that produces one step of motion for each step command (usually a pulse) received.

Indexer: Electronics which convert high level motion commands from a host computer, programmable controller, or operator panel into step and direction pulse streams for use by the stepping motor driver.

Inertia: The property of an object to resist changes in velocity unless acted upon by an outside force. Higher inertia objects require larger torques to accelerate and decelerate. Inertia is dependent upon the mass and shape of the object.

Inertial Match: An inertial match between motor and load is obtained by selecting the coupling ratio such that the load moment of inertia referred to the motor shaft is equal to the motor moment of inertia.

Limits: Motion control systems may have sensors called limits that alert the control electronics that the physical end of travel is being approached and that motion should stop.

Linear Coordinated Move: A coordinated move where the path between endpoints is a line.

Linearity: For a speed control system it is the maximum deviation between actual and set speed expressed as a percentage of set speed. Parameter is mechanical velocity.

Master Slave Motion Control: A type of coordinated motion control where the master axis position is used to generate one or more slave axis position commands.

Optically Isolated: A system or circuit that transmits signals with no direct electrical connection. Used to protectively isolate electrically noisy machine signals from low-level control logic.

Orthogonality: The degree of perpendicularity, or squareness, between the two axes in an X-Y or X-Z table. This parameter is usually measured in arc-seconds or microradians.

Oscillation: An effect that varies periodically between two values.

Overshoot: The amount that the parameter being controlled exceeds the desired value for a step input.

Phase-Locked Servo System: A hybrid control system in which the output of an optical tachometer is compared to a reference square wave signal to generate a system error signal proportional to both shaft velocity and position errors.

Point-to-Point Move: A multi-axis move from one point to another where each axis is controlled independently. (No coordination between axes is required).

Position Error: The difference between the present actuator (feedback) value and the desired position command for a position loop.

Position Feedback: Present actuator position as measured by a position transducer.

Power: The rate at which work is done. In motion control, Power = Torque x Speed.

Repeatability: The degree to which the positioning accuracy for a given move performed repetitively can be duplicated.

Resolution: The smallest positioning increment that can be achieved. Frequently defined as the number of steps or feedback units required for a motor's shaft to rotate one complete revolution.

Resolver: A position transducer utilizing magnetic coupling to measure absolute shaft position over one resolution.

Resonance: The effect of a periodic driving force that causes large amplitude increases at a particular frequency. (Resonance frequency).

Settling Time: The time required for a step response of a system parameter to stop oscillating or ringing and reach its final value.

Slew: In motion control, the portion of a move made at a constant non-zero velocity.

Slew Speed: The maximum velocity at which an encoder will be required to perform.

Stiffness: Ratio of an applied force or torque to change in position for a mechanical system. Ability of an object to resist deformation.

Straightness of Travel: Deviation from straight line motion in a horizontal plane. Also referred to as horizontal runout. This error is usually traceable to an underlying angular error of the ways.

T.I.R.: This stands for Total Indicator Reading, which reflects the total absolute deviation from a mean value (versus a + value which indicates the deviation from a nominal value).

Torque Constant: A number representing the relationship between motor input current and motor output torque. Typically expressed in units of torque/amp.

Torque Ripple: The cyclical variation of generated torque given by product of motor angular velocity and number of commutator segments.

Torque-to-Inertia Ratio: Defined as a motor's torque divided by the inertia of its rotor, the higher the ratio the higher the acceleration will be.

Transducer: Any device that translates a physical parameter into an electrical parameter. Tachometers and encoders are examples of transducers.

Velocity Ripple: Disturbances in the programmed velocity profile due to changes in magnetic flux and commutation switching.

Voltage Constant: (or Back EMF Constant) A number representing the relationship between Back EMF voltage and angular velocity. Typically expressed as V / kRPM.

Yaw: An angular deviation from ideal straight line motion, in which the positioning table rotates around the Z (vertical) Axis as it translates along its travel axis.

Find More Online:

For complete information on all other Parker Electromechanical product lines not covered in this catalog, please visit our website at:

www.parkermotion.com

Specific products can be located using the navigation bar menus along the top of the page, and the left column menu bar. In addition to comprehensive product information, the site also offers a host of other resources including:

- Application stories
- Engineering guides
- Sample markets
- Product manuals
- 3-D CAD files
- FAQ
- RSS news feeds
- Locate your local ATC
- Buy online
- And much more!

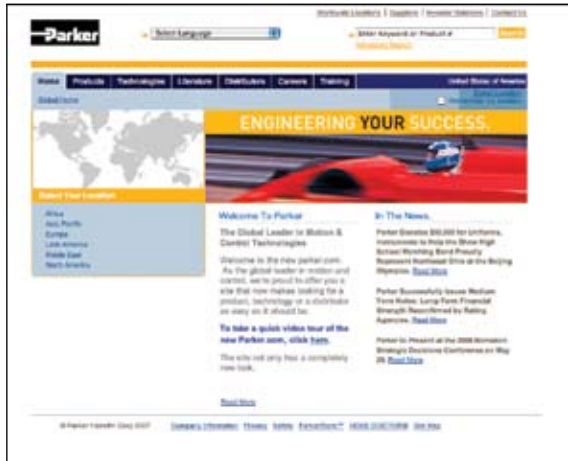

Parker Hannifin offers thousands of product lines ranging from viton seals and brass fittings to hydraulic cylinders with kilo-newtons of force.

To find out more about the complete Parker Hannifin family of products, please visit:

www.parker.com



Extensive Automation Solutions

HMI and Controllers



Superior integration and support for machine control as well as HMI hardware and software.

www.parkermotion.com/em/hmicont

Electric Actuators



Screw, belt-driven, and linear motor actuators for the complete range of industrial applications, offering precise motion and flexibility.

www.parkermotion.com/em/linear

Motors and Drives



Parker's family of innovative servo/stepper motors and drives continues to expand to meet the challenges of new technologies.

www.parkermotion.com/em/motordrive

Linear Actuators



Aluminum and steel pneumatic cylinders, guided cylinders, rodless cylinders, and short stroke thrusters from the industry leader.

www.parkermotion.com/pneu/linear

Rotary Actuators



Industry leader in the design and manufacture of pneumatic rack and pinion, and vane-style rotary actuators.

www.parker.com/pneu/rotary

Vacuum Products and Sensors



Vacuum solutions include a broad range of generators (integrated/inline), cups, and pressure sensors.

www.parker.com/pneu/vacsen

Grippers



Parallel, angular, and three jaw grippers are available in over 1,000 configurations.

www.parker.com/pneu/gripper

Airline Accessories



Airline accessories include silencers, flow controls, and mufflers to round out Parker's pneumatic solution.

www.parker.com/pneu/access

Air Control Valves



Valve technology that meets the most demanding requirements in any industrial application.

www.parker.com/pneu/valve

Air Preparation



Parker, the industry leader in air preparation, offers a complete line of products to ensure clean, dry, oil-free air.

www.parker.com/pneu/airprep

Connectors and Tubing



The most complete line of fluid connectors worldwide will meet virtually any automation application.

www.parker.com/pneu/fc

Parker IPS Structural Automation



More than 150 metric and inch profiles, integral motion components, and accessories for unlimited and flexible configurations. Pre-machined kits or complete assemblies.

www.parker.com/ips



New Parker Trilogy catalog. Call for your comprehensive guide today. 800-358-9070 96-028778-01/US

Parker also has product ranges available for the Precision Automation, Industrial Automation and Pneumatic markets, each paired with an interactive CD. Call 800-CPARKER.



Bulletin AU01-5000/US



Bulletin AU01-7500/US

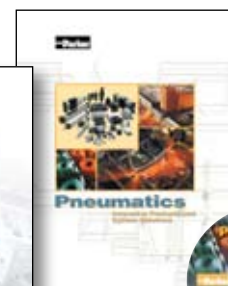

Bulletin AU01-1000/US



EM Sales Offices

Australia

Parker Hannifin (Australia) Pty Limited
9 Carrington Road
Castle Hill NSW 2154
Australia
Tel: +61 (0) 2 9634-7777
Fax: +61 (0) 2 9634 3749

Brazil

Parker Hannifin Ind. Com Ltda.
Av. Lucas Nogueira Garcez 2181
Esperança
12325-900 Jacareí, SP
Tel: 12 3954 5100
Fax: 12 3954 5262
Email: automation.brazil@parker.com

Canada

Parker Hannifin (Canada) Inc.
160 Chisholm Dr
Milton, Ontario L9T 3G9
Tel: 905-693-3000
Fax: 905-876-1958
Email: miltoncustservice@parker.com

China

Parker Hannifin Motion & Control (Shanghai) Co., Ltd
280 Yunqiao Rd. Jin Qiao Export Processing Zone
Shanghai 201206, China
Tel: (86-21) 50312525
Fax: (86-21) 64459717

France

Parker SSD Parvex
8 avenue du Lac
B.P. 249
F-21007 Dijon Cedex
Tel: +33 (0) 3 80 42 41 40
Fax: +33 (0) 3 80 42 41 23

Germany

**Electromechanical Europe
Parker Hannifin GmbH & Co KG**
Robert-Bosch-Strasse 22
D-77656 Offenburg
Germany
Tel: +49 (0) 781 509 0
Fax: +49 (0) 781 509 98176

India

**Parker Hannifin India Pvt. Ltd
Automation Group-SSD Drives Division**
133 & 151 Developed Plots Estate
Perungudi, Chennai 600 096
Tel: 044-4391-0799
Fax: 044-4391-0700

Italy

Parker Hannifin SpA
Via Gounod 1
20092 Cinsello Balsamo
Milano, Italy
Tel: +39 02 361081
Fax: +39 02 36108400

Korea

Parker Hannifin Korea
9th Floor KAMCO Yangjae Tower
949-3 Dogok 1-dong Gangnam-gu
Seoul 135-860, Korea
Tel: 82-2-559-0454
Fax: 82-2-556-8187

Mexico

Parker Hannifin de Mexico
Eje uno Norte No.100
Parque Industrial Toluca 2000
Toluca, CP 50100 México
Tel: 52-722-275-4200
Fax: 52-722-279-0316

Singapore

Parker Hannifin Singapore Pte Ltd
11, Fourth Chin Bee Road
Singapore 619702
Tel: (65) 6887 6300
Fax: (65) 6265 5125/6261 4929

Taiwan

Parker Hannifin Taiwan Co., Ltd
No. 40, Wuchiuan 3rd Road
Wuku Industrial Park
Taipei County, Taiwan 248
ROC
Tel: 886 2 2298 8987
Fax: 886 2 2298 8982

Thailand

Parker Hannifin (Thailand) Co., Ltd.
1023, 3rd Floor, TPS Building,
Pattanakarn Road,
Suanluang, Bangkok 10250
Thailand
Tel: (66) 02717 8140
Fax: (66) 02717 8148

UK

Parker Hannifin Ltd.
Tachbrook Park Drive
Tachbrook Park
Warwick CV34 6TU
Tel: +44 (0) 1926 317970
Fax: +44 (0) 1926 317980

USA

**Parker Hannifin Electromechanical
Automation Division Main Office/
Compumotor/CTC**
5500 Business Park Drive
Rohnert Park, CA 94928 USA
Tel: 707-584-7558
800-358-9070
Fax: 707-584-8015
Email: emn_support@parker.com

**Parker Hannifin Electromechanical
Automation Division/Bayside**
27 Seaview Boulevard
Port Washington, NY 11050
Tel: 516-484-5353
800-305-4555
Fax: 516-629-8000
Email: emn_support_bayside@parker.com

**Parker Hannifin Electromechanical
Automation Division/Daedal**
1140 Sandy Hill Road
Irwin, PA 15642
Tel: 724-861-8200
800-245-6903
Fax: 724-861-3330
Email: ddcat@parker.com

Catalog 8092 6/08
Printed in U.S.A



Parker Hannifin Corporation
Electromechanical Automation Div.
1140 Sandy Hill Road
Irwin, PA 15642
Tel: 800-245-6903
Email: emn_sales@parker.com
emn_support@parker.com



This catalog is printed on
100% recycled paper;
30% post-consumer content.