

Oilfield Products



The Right Connection™

www.comoso.com

Table of Contents

Holedall	3-7
external swage high pressure couplings	3
grade D rotary hose couplings	3
350 ton ram coupling machine.....	4
15 ton ram coupling machine.....	4
25 ton ram coupling machine.....	4
50 ton ram coupling machine.....	4
100 ton ram coupling machine.....	4
external swage coupling system	5
internal expansion coupling system.....	6
Scovill style internally expanded couplings.....	7
Hookie Hook Hose Lifter.....	7
Cam and Groove	8-9
swaged EZ Boss-Lock type C cam and groove	8
notched EZ Boss-Lock type C cam and groove	8
swaged Boss-Lock type E cam and groove	9
notched Boss-Lock type E cam and groove	9
crimp sleeves.....	9
Quick Disconnects	10-11
dry disconnect couplings	10
cam and groove style dry disconnect couplings	11
Hydraulic Fittings	12-14
Oilfield, WS series	12
Industrial, H series	12
Mobile General Purpose, K series.....	13
Wingstyle, W series	13
Flushface, HT series.....	13
Highflow Oilfield Flush Face, ST series.....	14
Snap-tite V/VH series	14
Enerpac, T/3000 series.....	14
Hammer Unions	15
Valves	16-19
stainless steel ball valves	16
brass ball valves	16, 17
locking handle brass ball valves	16
spring return handle ball valves.....	17
diverting ball valves	17
high pressure grooved end ball valves	18
ball cone check valves.....	18
locking handle stainless ball valves	18
iron butterfly valves.....	19
Ball-Joint Armored Hose	20
WS Series Blowout Prevention Safety Couplings	20
Swivel Joints	21
Boss Ground Joint Coupling System	22
Boss Male Stems	22
Boss Clamps	23
Oilfield Accessory Products	24
Pipe to Pipe Couplings	25
Installation and Inspection Procedures	26-27

Hose Coupling Safety

- Use Dixon couplings, retention devices and accessory products **only** for their intended service.
- All recommendations of the Hose Manufacturer, and the Coupling Manufacturer, must be employed with regards to **Size, Temperature, Application, Media, and Pressure** when selecting the components for a hose assembly.
- All finished hose assemblies should be tested in accordance with the Rubber Manufacturers Association recommendations.
- All hose assemblies should be thoroughly inspected prior to each use to ensure they are undamaged, and properly coupled.
- Use safety clips on couplings, and King Safety Cables on assemblies where required by the manufacturer, as well as State and Federal regulations. (OSHA regulations may be viewed in full on the OSHA website, www.osha.gov.)
- Under no circumstances should the assembly working pressure or working temperature exceed the working pressure or working temperature of the lowest rated component (coupling, clamp, ferrule, or hose).
- Call Dixon (800.355.1991) for advice on couplings, retention devices, and accessories for your application.

All dimensions illustrated in this brochure are nominal.

External

Swage High Pressure Couplings

For services requiring a fitting capable of withstanding extremely high pressures and severe operating conditions

Features:

- For services requiring extremely high pressure (up to 3,000 PSI) applications such as on small and medium size drilling rigs; used for slim hole, core drill, workover, seismograph, water well, blast or shot holes, etc.
- long, rugged fittings machined from seamless pipe and tubing with specially designed serrations
- mating ferrules machined from heavy wall material with matching serrations and rows of set screws ensure better coupling retention
- Couplings are shipped with matching ferrules. To ensure receipt of a properly sized ferrule please provide hose OD when ordering. Make sure both ends of the hose are measured for OD
- must be swaged with a 50 Ton, 100 Ton or 350 Ton Ram (page 4)
- API and NPT sizes are interchangeable

Material:

- Zinc plated steel

Sizes:

- available in 2", 2½" and 3"



stem

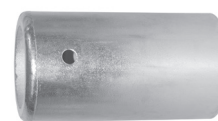

ferrule

Grade "D"

Rotary Hose Couplings

Independent, elevated temperature tested

Features:

- complies to API 7K specifications
- working pressure: 5,000 PSI
- test pressure: 10,000 PSI
- independent, elevated temperature tested to 180°F
- 95,000 lb. end pull test
- 15,000 cycle test at full working pressure

Sizes:

- available in 2½", 3" and 3½" ID

End Configurations:

- weld end and API male

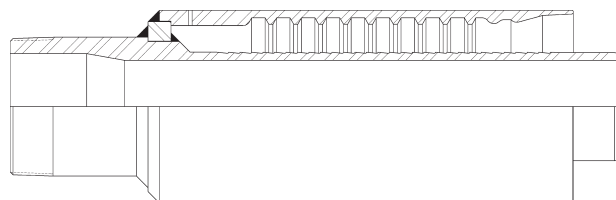
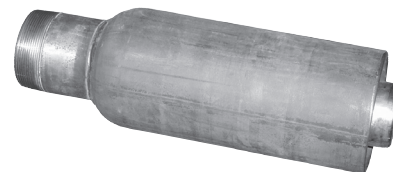

Holedall Coupling Machines

Powerful, finely engineered machines designed specifically to swage and internally expand Holedall couplings by hydraulic pressure.

All Rams require dies of the proper size to reduce the ferrule to the proper diameter for a good grip on the hose. Pushers of the proper size must be used on the end of the Ram to push the Holedall fitting through the die. Die and pusher selection depends on the sizes and types of hoses being coupled. Ferrule recommendations and a Die Chart binder are available upon request. Consult your Dixon representative for specific details.

15 Ton Ram

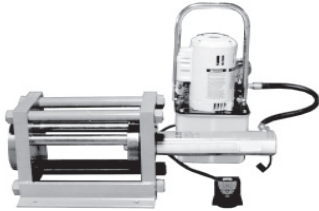

Features:

- designed for internally expanded couplings only
- bench mounted model (optional stand available)
- produces up to 10,000 PSI, for up to 15 tons of ram force
- expands 1" through 3" steel fittings and 3/4" through 4" brass Holedall petroleum fittings
- motor is 1/2 h.p., 115 volt, 60 cycle, single phase with foot pedal

25 Ton Ram



Features:

- free standing model
- produces up to 10,000 PSI of line pressure for up to 25 tons of ram force
- capable of external swaging 1/4" through 4" ID hose and internal expanding 5/8" through 4" ID hose, with proper equipment
- motor is 1/2 h.p., 115 volt, 60 cycle, single phase with foot pedal
- high speed pump kit option available

50 Ton Ram

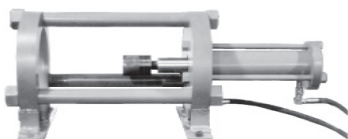

Features:

- bench mounted model (optional stand available)
- produces up to 10,000 PSI, for up to 50 tons of ram force
- with proper equipment externally swages 1 1/4" through 6" ID hose and internally expands 5/8" through 6" ID hose
- motor is 1-1/8 h.p., 115 volt, 60 cycle, single phase, standard with remote, 220/440 volt motors are available

100 Ton Ram

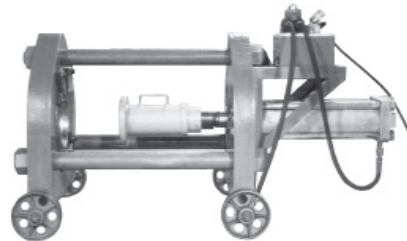

Features:

- swages Holedall fittings to hose from 1 1/4" through 10" ID
- with optional accessories, this ram may be used for internally expanded couplings on hose from 1 1/4" through 6"
- produces up to 100 tons of ram force
- motor is 1-1/8 h.p., 115 volt, 60 cycle, single phase standard with remote, 220/440 volt motors are available

350 Ton Ram

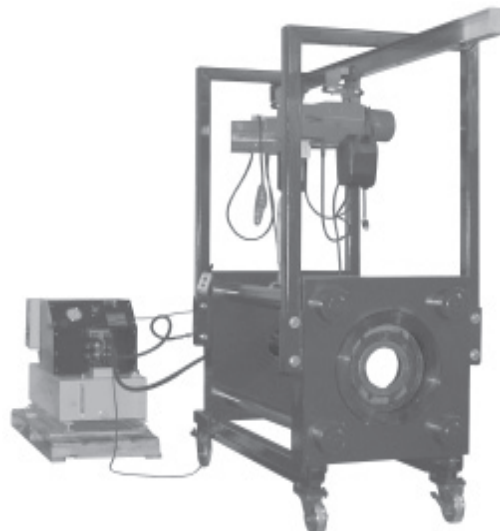

Features:

- long stroke allows swaging with one pusher, eliminating the need to stop the machine to add extensions
- 354 tons of swaging force ensures the ram will not stall out
- capable of producing 188 tons of pulling force allowing for internal expansion of fittings
- 10,000 PSI pump with 25 gallon reservoir
- 2 GPM flow rate at 10,000 PSI
- 3-phase motor is 12.5 h.p., 230 volt, 60 Hz, remote is standard

External Swage Coupling System

Provides outstanding strength, durability and safety by utilizing a progressive swage

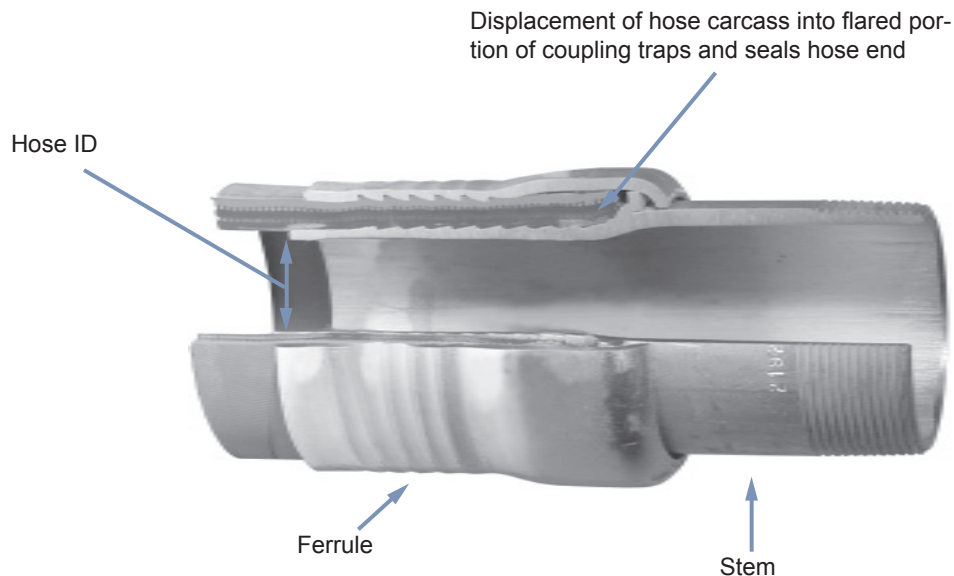

Features:

- Patented Holedall couplings include a Holedall stem and a specially engineered ferrule. The hydraulic swaging of the coupling to the hose is accomplished by pushing the ferrule through a die which reduces the ferrule OD. The ferrule penetrates the hose wall, providing a 360° uninterrupted compression band around the hose.
- A hydraulic ram is the only piece of machinery necessary to accomplish the coupling. Available in five different sizes - 15, 25, 50, 100 and 350 ton - these rams will accommodate dies and pushers of various sizes so that hoses up to 10" in diameter may be coupled.
- This multi-purpose, high pressure coupling system requires no bolts and results in a clean coupling with no protrusions. The swaging operation is fast and hose of various lengths and different styles can be coupled. Ease of operation, flexibility and economy make the Holedall method an unequalled assembly system.
- Couplings are furnished with pipe thread, plain end, victaulic grooved or flanged ends.
- Dixon Holedall stems and ferrules are specifically designed to be used together as a coupling system. Due to differences in dimensions and tolerances, for safety reasons, do not use other manufacturer's stems or ferrules with Dixon Holedall products.

SAFETY
ALERT

Material:

- stainless steel and carbon steel

Internal

Expansion Couplings

Essential when maximum flow is important

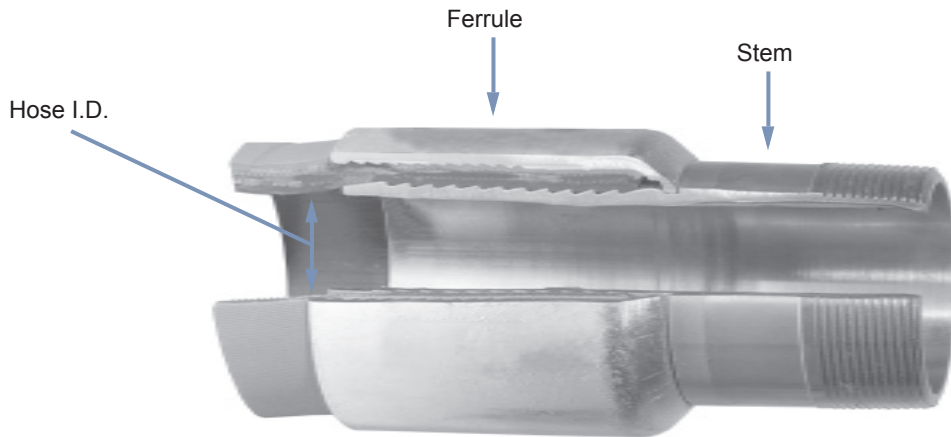

Features:

- only one expansion tool is needed for each hose ID
- streamlined, lightweight coupling consists of ferrule and stem, no protrusions to snag on equipment
- Recommended applications for these fittings include: concrete pump hose, plaster and grout hose, oil suction and discharge hose, multi-purpose heavy duty air hose, jetting hose, barge loading hose and bottom loading hose.
- maximum flow of media
- reduction of turbulence through hose
- excellent sealing and retention characteristics
- outperforms band clamps
- easy and consistent installation
- Dixon Holedall stems and ferrules are specifically designed to be used together as a coupling system. Due to differences in dimensions and tolerances, for safety reasons, do not use other manufacturer's stems or ferrules with Dixon Holedall products.

SAFETY
ALERT

End Configurations:

- male NPT
- raised California
- victaulic
- other end configurations available on request

Scovill Style

Internally Expanded Couplings

For discharge and suction service

Features:

- commonly used in the fuel transfer industry to homes, airplanes, ships, etc.
- Couplings are compact, light and streamlined to eliminate catching on curbs and shrubs.
- 520-H fittings are designed for internal expansion only
- couplings are pre-lubricated for assembly
- Hand and electrically operated installation equipment is available. Consult factory for pricing and availability.
- The working pressure of the 520-H fitting varies with the size of the fitting, the size and construction of the hose and the media being conveyed. Consult the factory for recommendations.
- Dixon Holedall stems and ferrules are specifically designed to be used together as a coupling system. Due to differences in dimensions and tolerances, for safety reasons, do not use other manufacturer's stems or ferrules with Dixon Holedall products.
- intended for fuel delivery service
- Both the male and female fittings have octagonal facets for tightening with a wrench. The 1½" and larger size females have special lugs for tightening. Couplings grip hose firmly over a broad area to provide a permanent, trouble-free assembly. The stem is expanded to nominal ID of hose for a rigid, uniform, full-flow area.

**SAFETY
ALERT**

Material:

- male and female stems machined from bar stock or solid brass forgings
- ferrules are available in brass and stainless steel

Sizes:

- 520-H series available in ¾", 1", 1¼", 1-3/8", 1½", 2", 2½", 3", and 4"
- 520-G series available in 1", 1½", 2" and 2½"

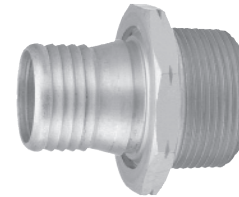

520-H series
male

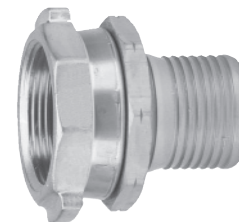

520-H series
female



520-G series
grooved/victaulic type

Hookie Hook Hose Lifter

For bulk loading or rig supply hose operations in off-shore applications

Features:

- stems are yellow zinc plated in accordance with BS1706: 1990 as standard, with threads to API standard 5B: 1988
- Internal swage ferrules are available in yellow zinc plated or powder coat finishes in accordance with the UKOOA (United Kingdom Offshore Operators Association) color system
- Hose lifters are supplied with proof load test certificates and are specifically designed for use with bulk loading hose. Hookie Hook stems are also available, contact the factory for additional information

Materials:

- forged steel or aluminum bronze

Sizes:

- available in 3", 4" and 5"

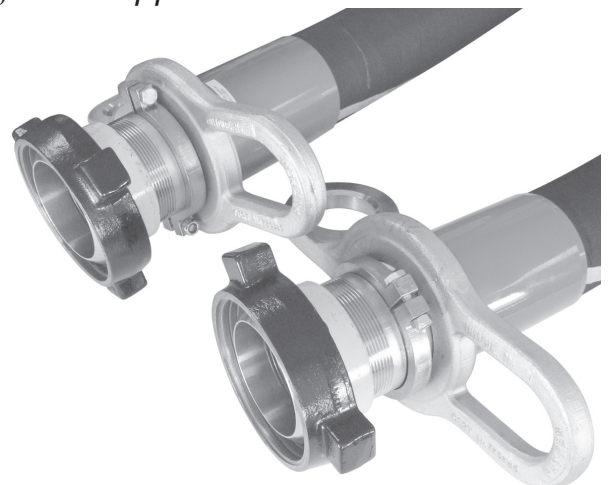

Type C and E

Swaged & Notched Cam and Groove

Provides a permanently attached cam and groove fitting when superior coupling retention is required

Swaged EZ Boss-Lock Type C Cam and Groove Couplers



coupler x hose shank with ferrule

Features:

- Developed specifically for chemical transport hoses having Crosslinked Polyethylene (XLPE) or Ultra High Molecular Weight Polyethylene (UHMW) tubes. In testing tank transport hoses from a wide variety of manufacturers, the swaged EZ Boss-Lock fittings proved to be the clear winner in overall performance.

Sizes:

- coupler available in ¾" and 1"

Material:

- 316 stainless steel

Notched EZ Boss-Lock Type C Cam and Groove Couplers



coupler x hose shank

Features:

- The notched EZ Boss-Lock system allows you to better manage your inventory. You can stock one coupling and two ferrules, covering the same hose range with less inventory. *You must purchase a fitting and the matching ferrule to create an assembly.*



- The largest advantage of the notched EZ Boss-Lock design is that the coupling can be removed from a damaged hose by cutting away the ferrule without necessarily damaging the fitting. *After inspection to determine its suitability for reuse, it can be reinstalled into another hose by using a new ferrule.*



- *Dixon stems and ferrules are specifically designed to be used together as a coupling system. Due to differences in dimensions and tolerances, for safety reasons, do not use other manufacturer's stems or ferrules with Dixon Holedall products.*

Sizes:

- coupler available 1½", 2", 3" and 4"
notched ferrule available in 1½", 2", 3" and 4"

Material:

- 316 stainless steel

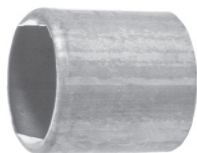

notched ferrule

Stainless steel crimp sleeves for Dixon couplers and adapters are available on the next page.

Swaged Boss-Lock Type E Cam and Groove Adapters

Features:

- Developed specifically for chemical transport hoses having Crosslinked Polyethylene (XLPE) or Ultra High Molecular Weight Polyethylene (UHMW) tubes. In testing tank transport hoses from a wide variety of manufacturers, the swaged Boss-Lock fittings proved to be the clear winner in overall performance.

Sizes:

- coupler available in ¾" and 1"

Material:

- 316 stainless steel



adapter x hose shank with ferrule

Notched Boss-Lock Type E Cam and Groove Adapters

Features:

- The largest advantage of the notched Boss-Lock design is that the coupling can be removed from a damaged hose by cutting away the ferrule without necessarily damaging the fitting. *After inspection to determine its suitability for reuse, it can be reinstalled into another hose by using a new ferrule.*
- The notched Boss-Lock system allows you to better manage your inventories. You can stock one coupling and two ferrules, covering the same hose range with less inventory. *You must purchase a fitting and the matching ferrule to create an assembly.*
- *Dixon stems and ferrules are specifically designed to be used together as a coupling system. Due to differences in dimensions and tolerances, for safety reasons, do not use other manufacturer's stems or ferrules with Dixon Holedall products.*

SAFETY
ALERT

SAFETY
ALERT

SAFETY
ALERT



adapter x hose shank

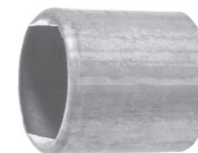

notched ferrule

Sizes:

- coupler available in 1½", 2", 3" and 4"
notched ferrule available in 1½", 2", 3" and 4"

Material:

- 316 stainless steel

Crimp Sleeves

Features:

- Hose OD ranges for crimp sleeves are the same as for Dixon's standard cam and groove notched ferrules.
- *Dixon stems and ferrules are specifically designed to be used together as a coupling system. Due to differences in dimensions and tolerances, for safety reasons, do not use other manufacturer's stems or ferrules with Dixon Holedall products.*
- The crimp sleeve is not designed to be used in applications where the assembly is exposed to high temperatures.

SAFETY
ALERT



Sizes:

- available in 2" and 3"

Material:

- 304 stainless steel, carbon steel is also available contact the factory for pricing and availability

Dixon

Dry Disconnect Couplings

Connect and disconnect hose and pipelines without accidental spillage and product loss

Service:

- working pressure -
 - aluminum 260 PSI
 - stainless steel 360 PSI
 - brass / gunmetal 360 PSI

General Features:

- easy to handle - push and turn - free flow; turn and pull - closed
- time saving - no need to drain hoses or pipe systems
- economical - no loss or spillage of liquids at connection or disconnection
- safety- the valve cannot be opened until the unit is coupled
- environment friendly - accidental spillage eliminated
- safe and reliable - due to rugged construction
- To avoid product contamination caused by connecting a coupler to the wrong adapter, selective versions of the adapters are available. Contact the factory for further information.
- product life - uncomplicated design and high quality materials ensures longer product life
- interchanges with Avery Hardoll and Todo-matic®
- seal kits are available

Sizes:

- couplers available in ¾", 1", 1½", 2", 3", 4" and 6"
- dust plugs available in ¾", 1", 1½", 2", 3", 4" and 6"
- adapters available in ¾", 1", 1½", 2", 3", 4" and 6"
- composite dust caps available in ¾", 1", 1½", 2", 3", 4" and 6"
- rubber dust caps available in 1" and 2"

Materials:

- 316 stainless steel, anodized aluminum, brass / gunmetal
- standard seal - Viton®
 - optional seals- EPDM, NBR - nitrile, Kalrez®, Chemraz®, Perlast®

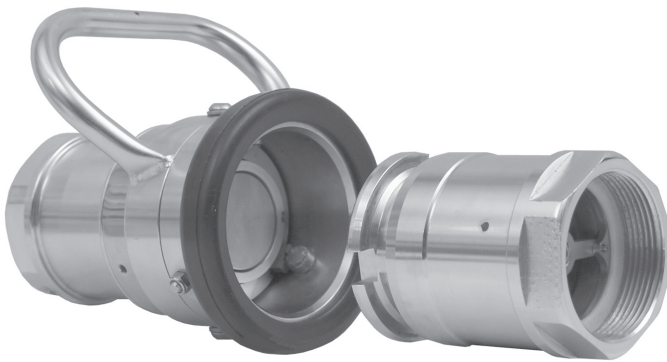

How it works

The principle of operation is identical for all sizes of couplings.

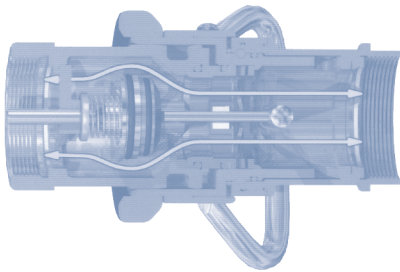

Open:

- push and turn, it is coupled - *full flow*

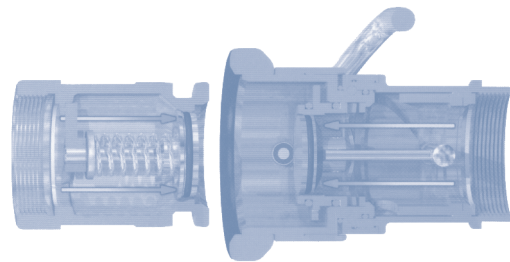

Closed:

- turn and pull, it is released - *no spillage*

Cam and Groove Style

Dry Disconnect Couplings

Connect and disconnect hose and pipelines without accidental spillage and product loss

General Features:

- compatible with most cam and groove style dry disconnects
- spring loaded sealing device designed to "snap" closed should the valve become disconnected with the poppet open
- Contact the factory for chemical compatibility, size, and material selection. Special configurations can be designed for your application.

Adapter Features:

- two-piece adapter design for easy rebuilding of adapters
- fully interchangeable with Kamvalok (OPW trademark) style fittings
- aluminum fittings have aluminum nose piece and brass piston

Coupler Features:

- Dixon EZ Boss-Lock cam arms provide high security from accidental opening due to vibration or snagging.
- heavy duty stainless steel crank and link provides long service life.
- dry disconnect coupler has automatic closing poppet assembly
- stainless steel handle allows product exposure to corrosive chemicals or washdown service
- strong handle attachment prevents sheared pins and misaligned crank assemblies
- fully interchangeable with Kamvalok (OPW trademark) style fittings
- aluminum fittings have stainless steel (corrosion resistance comparable to 304 stainless) internals
- a DBA style adapter (sold separately) is required for the coupler to operate

**SAFETY
ALERT**

Sizes:

- couplers available in 1½", 2" and 3"
- adapters available in 1½", 2" and 3"

Materials:

- stainless steel, aluminum
- adapter seals-
 - Buna
 - Viton®
 - PTFE Encapsulated Silicone
 - EPT
 - Chemraz®
 - PTFE Encapsulated Viton®
- coupler seals-
 - Buna
 - Viton®
 - EPT
 - PTFE Encapsulated Silicone and Kelraz®
 - PTFE Encapsulated Silicone and Chemraz®
 - PTFE Encapsulated Viton® and Chemraz®
 - Chemraz® and PTFE



1½" and 2" DBA adapter



3" DBA adapter



1½" and 2" straight coupler



3" straight coupler



90° swivel

Delrin®, Kevlar® and Zytel® are registered trademarks of E.I. duPont Nemours and Company. Kalrez® and Viton® are registered trademarks of DuPont Dow Elastomers.

Dixon, 877.963.4966

Hydraulic Quick Disconnect Couplings

Serving the market for coupling sizes of 2" or below, these products are used in a variety of hydraulic and pneumatic applications

Oilfield Series WS-Series Snap-Tite 75 Interchange

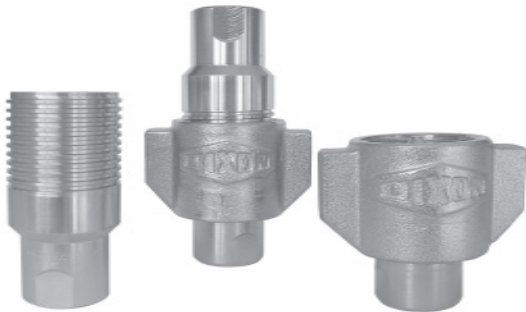

Features:

- sleeve is cast using a unique process that provides improved surface finishes, tighter tolerance control and excellent repeatability
- Heavy duty hammer lugs are designed to provide optimum durability during connection and disconnection
- Seals are easily field replaceable, including the valve seal, which can be replaced without replacing the whole valve
- Comply with applicable Det Norske Veritas North Sea standards for coupling applications
- Unique initial-thread profile ensures nipple longevity in the toughest environments

Sizes:

- available in ¾", 1", 1¼", 1½" and 2"

Material:

- coupler and nipple: steel, 316 stainless
- dust plug and cap: aluminum body with stainless steel bead chain

Industrial Hydraulic Series H-Series ISO7241 Series B Interchange



SAFETY
ALERT

Features:

- couplers and nipples comply with ISO7241, Series B
- wide variety of body and seal materials and thread configurations maximize compatibility in a variety of applications
- large diameter heavy duty knurled sleeves are designed to resist brinelling and maximize performance under impulse conditions
- not recommended for BOP (blow out prevention) systems

Sizes:

- available in 1/8", ¼", 3/8", ½", ¾", 1", 1¼" and 1½"

Material:

- coupler and nipple: steel, brass, 303 stainless, 316 stainless
- dust plug and cap: elastomer body and lanyard
- rigid dust plug and cap: aluminum body, steel ring
- protective pressure cap - steel

Mobile General Purpose Series

K / 5600-Series ISO7241 Series A Interchange

Features:

- couplers and nipples comply with ISO7241 Series A
- couplers have a high concentration of locking balls to reduce incidents of brinelling during operation
- heavy duty knurled sleeves are designed to resist brinelling (to create round indentations in a metal surface) and maximize performance under impulse conditions
- wide variety of thread configurations maximize compatibility in a variety of applications

Sizes:

- available in 1/4", 3/8", 1/2", 3/4", 1", 1 1/4", 1 1/2" and 2"

Material:

- coupler and nipple: steel
- dust plug and cap: elastomer body and lanyard



Wingstyle Series

W / 7800-Series Wing Interchange

Features:

- threaded wing or hex sleeves enable easy connection and disconnection while under pressure
- O-ring connected marker is highly visible during connection, and helps keep contaminants out of the threads while connected
- coupler has a high flow tubular valve designed to reduce pressure drop and turbulence while improving flow performance
- bulkhead mounting kits available to secure nipples for simplified connection and disconnection
- flanged bonded seal prolongs coupling life and is integral in the reduction of spillage and air inclusion

Sizes:

- available in 3/4", 1", 1 1/4" and 1 1/2"

Material:

- coupler and nipple: brass, steel wing nut
- dust plug and cap: brass body with stainless steel bead chain
- nipple mounting flange: steel



Flush Face Series

HT-Series ISO16028 Flushface Interchange

Features:

- patented coupler-stem retention system provides optimum performance during surge flow, burst and impulse pressure
- couplers have a high concentration of locking balls to reduce incidents of brinelling during operation
- couplings designed to exceed 1,000,000 cycles during impulse testing, making them ideal for hammers
- heavy duty grooved sleeves are versatile, rugged and ideal for bulkhead mounting
- wide selection of seal and body materials provides optimum versatility in a variety of applications

Sizes:

- available in 3/8", 1/2", 5/8", 3/4" and 1"

Material:

- coupler and nipple: steel, 316 stainless
- dust cap: elastomer body and lanyard



High Flow Oilfield Flush Face Series ST-Series Snap-tite 71 Interchange



Features:

- design minimizes air inclusion during connection and fluid loss during disconnection
- heavy duty grooved sleeves provide bulkhead mounting options and reduce instances of brinelling
- designed to exceed 1,000,000 cycles during impulse pressure conditions
- couplings comply with applicable Det Norske Veritas North Sea standards for coupling applications
- available in a wide variety of materials, including high pressure stainless steel configurations upon request

Sizes:

- available in 1/4", 3/8", 1/2", 3/4", 1" and 2"

Material:

- coupler and nipple: steel, 316 stainless
- dust cap: aluminum body with stainless steel bead chain

Snap-tite Series V / VH-Series Snap-tite H / IH Interchange



Features:

- couplers and nipples comply with MIL-C-51234
- couplers have a high concentration of locking balls to reduce incidents of brinelling during operation
- large diameter heavy duty knurled sleeves are designed to resist brinelling and maximize performance under impulse conditions
- available in single shut-off, double shut-off, or straight through configurations with a wide selection of end connections

Sizes:

- available in 1/4", 3/8", 1/2", 3/4", 1", 1 1/4", 1 1/2" and 2"

Material:

- coupler and nipple: steel, brass, 316 stainless
- rigid dust plug and cap: aluminum body with stainless steel bead chain

Enerpac Series T / 3000-Series High Pressure Screw-Together Interchange



Features:

- threaded sleeve allows connection and disconnection while coupler and/or nipple are under pressure
- urethane seal resists extrusion under high pressure during connection and disconnection

Sizes:

- available in 1/4" and 3/8"

Material:

- coupler and nipple: steel, 316 stainless
- dust plug and cap: steel body with steel chain lanyard

Dixon

Hammer Unions

Color coded connectors for temporary pipe and flow line installations



100 Series

100 Series

Features:

- used on low pressure manifolds and lines and in applications running air, water, oil or gas up to 1,000 PSI NSCWP (non-shock cold working pressure)
- yellow sub, black nut

Sizes:

- available in 2", 2½", 3", 4", 6" and 8"
-

200 Series

Features:

- used in general service applications running air, water, oil or gas up to 2,000 PSI NSCWP (non-shock cold working pressure)
- grey sub, blue nut

Sizes:

- available in 1", 1½", 2", 2½", 3", 4" and 6"
-

206 Series

Features:

- O-ring mounted sub provides excellent sealing properties
- runs air, water, oil or gas up to 2,000 PSI NSCWP (non-shock cold working pressure)
- grey sub, blue nut

Sizes:

- available in 1", 1½", 2", 2½", 3", 4" and 6"
-

602 Series

Features:

- lip type seal ring minimizes fluid flow turbulence while creating a pressure seal
- for use in mud, manifold service and truck mounting applications running air, water, oil, gas or mud up to 6,000 PSI NSCWP (non-shock cold working pressure)
- orange sub, black nut

Sizes:

- available in 1" and 2"
-

1002 Series

Features:

- lip type seal ring minimizes fluid flow turbulence while creating a pressure seal
- for use in high pressure systems and truck mounting applications running air, water, oil, gas or mud up to 10,000 PSI NSCWP (non-shock cold working pressure)
- blue sub, red nut

Sizes:

- available in 1", 2" and 4"
-

1502 Series

Features:

- lip type seal ring minimizes fluid flow turbulence while creating a pressure seal
- for use in extreme high pressure applications running air, water, oil, gas or mud up to 15,000 PSI NSCWP (non-shock cold working pressure)
- red sub, blue nut

Sizes:

- available in 2"
-

- Note: socket weld configurations and other materials are available, contact the factory for further information.
- Mismatching components of 1 series with another (i.e. 602 series with 1502 series) can lead to destruction of property, serious bodily injury or death.



Ball, Check and Butterfly Valves

Valves

For the control of air, water, oil and gas in hose or pipe lines

Domestic Brass Ball Valves

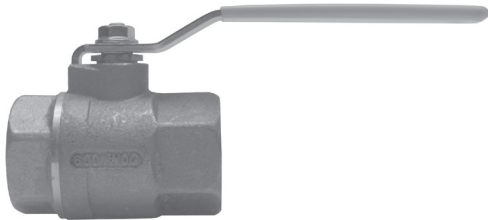

Female NPT x Female NPT

Features:

- for control of air, water, oil and gas in hose or pipe lines, for other services, please contact the factory
- rated to 600 PSI WOG; 150 PSI saturated steam
- brass valve bodies, balls and stems
- blow-out proof stems
- glass-filled reinforced PTFE seats and stuffing box ring; stem seals and washers.
- plated steel handles and nuts with vinyl sleeves, both styles repairable
- meets WW-V 35C, Type II Composition
- ball valve handle replacements available, consult factory for pricing
- 1/4", 3/8" and 1/2" available in full port design
- 3/4", 1", 1 1/4", 1 1/2" and 2" available in standard port design

Locking Handle Brass Ball Valves

sliding lock mechanism

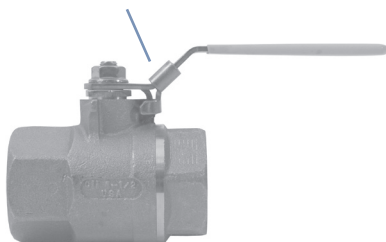

female NPT x female NPT

Features:

- for control of air, water, oil and gas in hose or pipe lines, for other services, please contact the factory
- rated to 600 PSI WOG; 150 PSI steam
- blow-out proof RPTFE stem
- chrome-plated brass ball
- stainless steel sliding lock mechanism secures handle in open or closed position; can be padlocked opened or closed.
- 1/4", 3/8" and 1/2" available in full port design
- 3/4", 1", 1 1/4", 1 1/2" and 2" available in standard port design



Global Brass Ball Valves

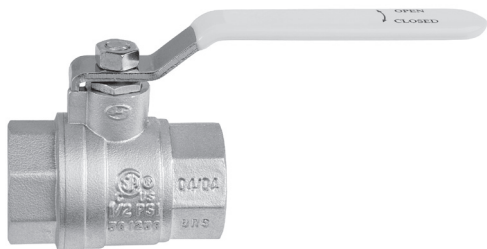

female NPT x female NPT

Features:

- for control of air, water, oil and gas in hose or pipe lines
- rated to 600 PSI WOG
- body: forged brass, UNS#C37700
- adjustable stem packing nut
- silicone free
- temperature range to 300°F (150°C)
- Underwriters approved
- CSA (Canadian Standards Association) approved
- 1/2", 3/4", 1", 1 1/4", 1 1/2" and 2" available in full port design

Stainless Steel Reduced Port Ball Valves



reduced port female NPT x female NPT

Features:

- for use in water, oil and gas
- 1/4" - 1" rated to 2000 PSI (CWP); 1 1/4" - 2" rated to 1500 PSI (CWP)
- body conforms to ASTM A-351 Grade CF8M
- ball is 316 stainless steel
- PTFE, glass filled seat
- blow-out proof stem design
- 1/4", 3/8", 1/2", 3/4", 1", 1 1/4", 1 1/2" and 2" available in reduced port design

"Deadman" Spring Return Handle Ball Valves

Bronze Features:

- rated to 600 PSI WOG; 150 PSI saturated steam
- vacuum service to 29 inches Hg
- threaded bronze valve
- stainless steel lever
- Chromium plated ball
- RTFE seats and stuffing box ring
- blow-out proof stem design
- adjustable packing gland
- spring return closes valve when not held open
- operating torque approximately three times standard valve torque.
- ½" available in full port design
- ¾", 1", 1½" and 2" available in standard port design

316 Stainless Steel Features:

- rated to 2000 PSI WOG ½" to 1"; 1500 PSI WOG 1¼" to 2"
- 150 PSI saturated steam, all sizes
- vacuum service to 29 inches Hg, all sizes
- PTFE seals
- blow-out proof stem design
- adjustable packing gland
- spring return closes valve when not held open
- operating torque approximately three times standard valve torque

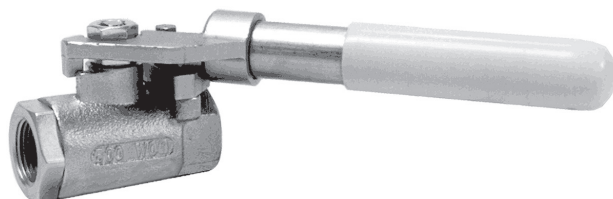

female NPT x female NPT

3-Way Diversion Ball Valves

Bronze Features:

- bronze body
- can be used with gasoline and diesel fuel
- rated to 400 PSI WOG
- blow out proof stem
- Chromium-plated ball
- RPTFE seats and stuffing box ring
- stainless steel handle and nut with vinyl sleeve
- adjustable packing gland
- ½" available in full port
- ¾" and 1" available in standard port design

Stainless Features:

- stainless steel body and ball
- rated to 800 PSI WOG
- blow out proof stem
- RPTFE seats and stuffing box ring
- stainless steel handle and nut with vinyl sleeve
- adjustable packing gland
- meets NACE MR-01-75
- ½" available in full port design
- ¾" and 1" available in standard port design



L flow pattern
female NPT x female NPT x female NPT

3-Way Diverting Ball Valves

Features:

- rated to 400 PSI WOG; 100 PSI saturated steam
- brass body
- blow out proof stem
- chrome plated brass ball
- PTFE seats, seals, and thrust washer
- adjustable stem packing
- temperature range to 320°F
- ½", ¾", 1", 1¼", 1½" and 2" available in standard port design

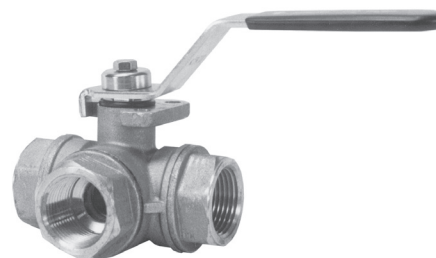

T flow pattern
female NPT x female NPT x female NPT

Locking Handle Stainless Steel Ball Valves

sliding lock mechanism

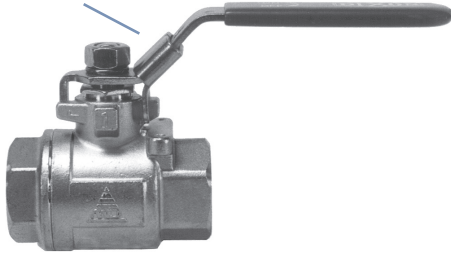

full port with locking handle
female NPT x female NPT

Features:

- for use in water, oil and gas
- rated to 1000 PSI WOG; 100 PSI saturated steam
- 316 stainless steel body, ball and stem
- PTFE seat, joint gasket and thrust washer
- plastic cover on handle
- blow-out proof stem design
- temperature range -60°F to 450°F
- 1/4", 3/8", 1/2", 3/4", 1", 1 1/4", 1 1/2" and 2" available in full port design

sliding lock mechanism

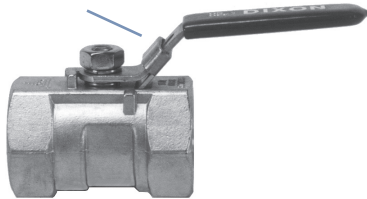

reduced port with locking handle
female NPT x female NPT

Features:

- for use in water, oil and gas
- rated to 800 PSI WOG; 100 PSI saturated steam
- 316 stainless steel body, ball and stem
- PTFE seat, joint gasket and thrust washer
- plastic cover on handle
- blow-out proof stem design
- temperature range -60°F to 450°F
- 1/4", 3/8", 1/2", 3/4", 1", 1 1/4", 1 1/2" and 2" available in reduced port design

Compact High Pressure Grooved End Ball Valves

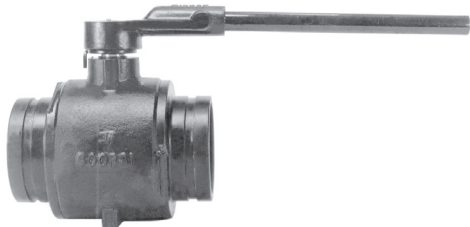

grooved end x grooved end

Features:

- suitable for many applications in high pressure pipeline systems, including petroleum, process systems, water, oil and gas
- rated to 600 PSI
- ductile iron
- epoxy coated high strength ductile iron body
- 316 stainless steel ball and stem
- 15% glass reinforced PTFE seats
- temperature rated to 450°F
- available in 4" and 6"

Ball Cone Check Valves

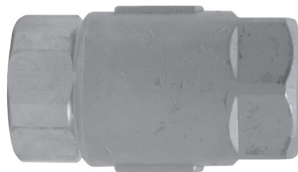

female NPT x female NPT



female NPT x male NPT

Features:

- For use with water, oil, air lines or inert gases. Not recommended for use on or near reciprocating pumps or other similar *vibration causing machinery*.
- tight shut-off with liquid media
- no radial alignment necessary
- straight through and streamlined for minimum change in velocity
- reinforced TFE check is spring loaded for fast seating action
- rated to 400 PSIG WOG, cold non-shock; 125 PSIG saturated steam
- cracking pressure is .5 PSI
- temperature range -20°F to 353°F
- 1/4", 3/8", 1/2", 3/4", 1", 1 1/4", 1 1/2", 2", 2 1/2" and 3" available in brass (female NPT x female NPT)
- 1/4", 3/8", 1/2", 3/4" and 1" available in stainless (female NPT x female NPT)
- 1/4", 3/8", 1/2", 3/4", 1", 1 1/4", 1 1/2" and 2" available in brass (male NPT x female NPT)

High Pressure Full-Bore Hydraulic Ball Valves

Features:

- blow-out proof stem
- rugged construction
- Viton® shaft seals
- female NPTF and SAE ORB threads
- available in carbon and stainless

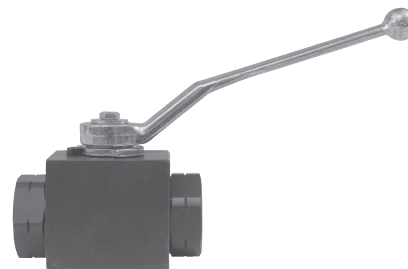

female NPTF x female NPTF

Ductile Iron Butterfly Valves

NOT RECOMMENDED FOR STEAM SERVICE



Pictures are representative, different size valves have different hole patterns.

Threaded Lug Style with bronze disc

Features:

- for use between two 150 lb. flanges
- will lock "open" or "closed"
- rated to 200 PSI
- ductile iron body, ASTM A126, class B
- aluminum bronze disc, ASTM B148, ALY.954
- Buna-N seal and stem seals
- available with Buna-N and EPDM liners
- PTFE bushing
- stainless steel top and bottom stems
- available in 2", 3", 4" and 6"



Wafer Style with bronze disc

Features:

- for use between two 150 lb. flanges
- will lock "open" or "closed"
- rated to 200 PSI
- ductile iron body, ASTM A126, class B
- aluminum bronze disc, ASTM B148, ALY.954
- Buna-N seal and stem seals
- available with Buna-N and EPDM liners
- PTFE bushing
- stainless steel top and bottom stems
- available in 2", 3", 4" and 6"



Wafer Style with stainless disc

Features:

- for use between two 150 lb. flanges
- will lock "open" or "closed"
- rated to 200 PSI
- ductile iron body, ASTM A536
- stainless steel disc, ASTM A351, GR. CF-8M
- Buna-N seal, stem seals and liner
- PTFE bushing
- stainless steel top and bottom stems
- available in 2", 3", 4" and 6"



GSM Ball-Joint Armored Hose

A flexible connector for demanding service conditions

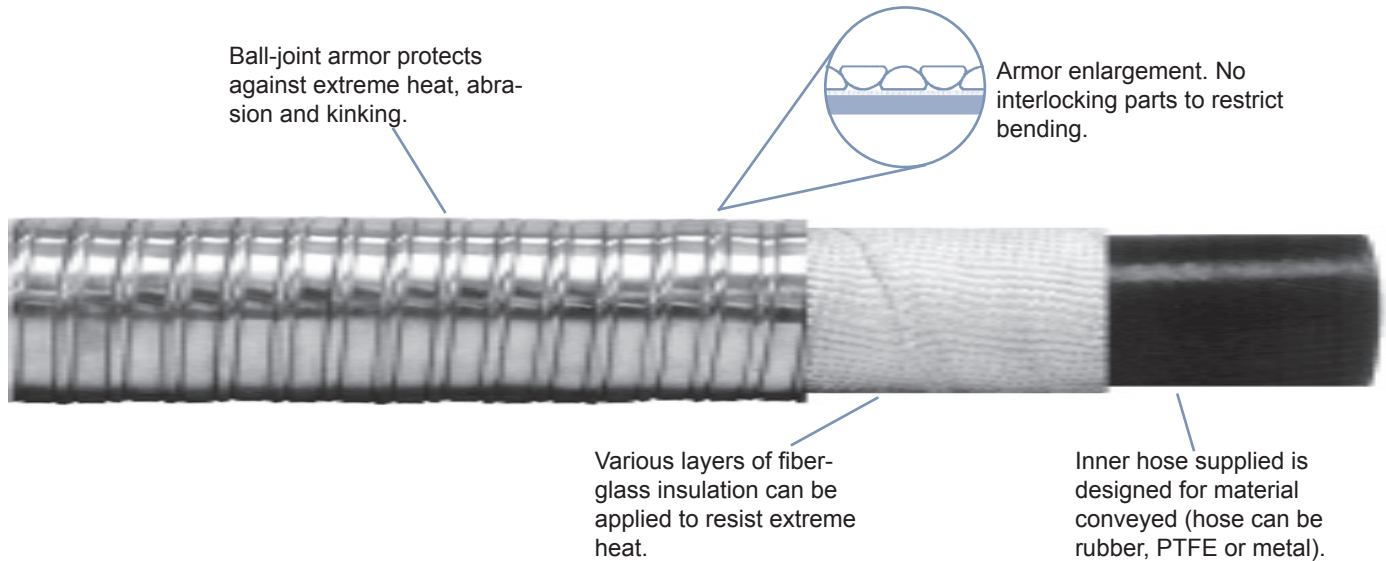

Features:

- A combination of insulation and GSM exclusive ball-joint armor protects hose from extreme heat, flame, abrasion, molten splash and kinking.
- GSM armor is applied directly over two wraps of insulation, leaving no gap between the armor and the hose.
- The insulation and armor are applied under controlled tension resulting in an integrated union of armor to the hose O.D.

Materials:

- galvanized steel and stainless steel

Sizes:

- ¼" - 12"

WS Series Blowout Prevention Couplings

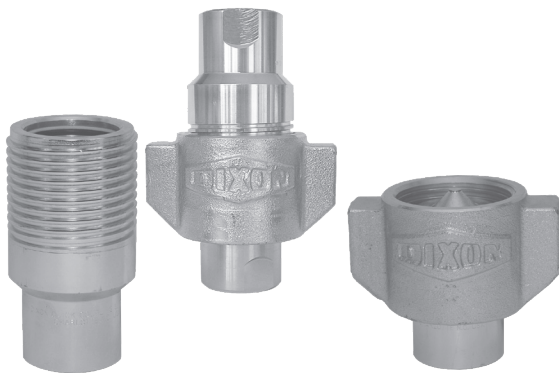

Features:

- fire tested and Lloyd's certified to 700°C (1300°F) in accordance with API 16D (Certificate #NAO 0601041/1)
- Designed for hazardous area service where couplings are required to operate under fire conditions in an emergency.
- Sleeve is cast using a shell cast method that provides a better surface finish, tighter tolerance control, and excellent repeatability.
- Blowout Prevention Couplings are individually marked with the BOP series designation

Material:

- coupler and nipple: steel, 316 stainless

Sizes:

- available in ¾", 1", 1¼", 1½" and 2"

Performance Specifications	Operating Bar	Pressure PSI	Coupled Burst Bar (PSI)	Flow Rate ΔP=1 Bar	Locking Mechanism
¾" steel	345	5,000	1,380 (20,000)	157 LPM (40 GPM)	Threaded
1" steel	345	5,000	1,380 (20,000)	227 LPM (60 GPM)	Threaded
1¼" steel	345	5,000	1,035 (15,000)	310 LPM (82 GPM)	Threaded
1½" steel	345	5,000	1,035 (15,000)	416 LPM (110 GPM)	Threaded
2" steel	345	5,000	1,035 (15,000)	908 LPM (240 GPM)	Threaded

Dixon

Swivel Joints

Full 360° rotational movement offers the maximum in flexibility

General Features:

- wide spacing between dual ball bearing raceways ensures greater load-bearing capacity
- precision-machined design ensures alignment and years of trouble-free service
- O-ring dust seal protects ball races and seal chamber from all outside elements
- radius elbow design ensures a smooth flow pattern
- optional 100% full penetration welding available

O-Ring Style Features:

- The O-ring pressure seal ensures a leak-proof seal at either high or low pressure and smoother rotation at lower torques than multiple seal designs.
- Spring-loaded PTFE pressure seals are available up through 3".
- Carbon steel and stainless steel O-ring type swivels provide greater strength and corrosion resistance when needed for lower torque applications.

V-Ring Style Features:

- The spring-loaded triple V-ring sealing system ensures a leak-proof seal at either high or low pressure and an extended seal life compared to the conventional single O-ring design.
- The 3" - 8" carbon steel swivels are manufactured from carbon steel with flame hardened dual raceways for greater load bearing capacity and longer life.
- The stainless steel swivels are manufactured in 316 grade stainless steel for superior corrosion resistance.
- available with pressure ratings to 1,000 PSI

Materials:

- V-ring type: carbon steel, stainless steel, aluminum
- O-ring type: carbon steel, stainless steel, aluminum, brass and iron

Sizes:

- V-ring type available in 2", 3", 4", 6" and 8"
- O-ring type available in 1", 1¼", 1½", 2", 3" and 4"



Boss

Ground Joint Coupling System

Boss couplings are all-purpose hose couplings, universally recommended for steam hose connections.

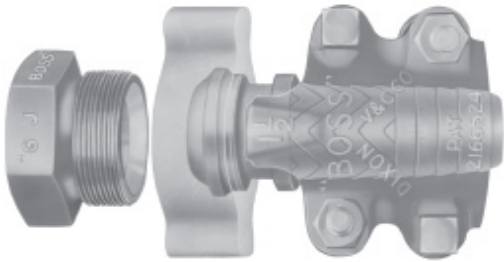

Service:

- used for steam, air, water, fluid petroleum and chemicals
- can be used for liquid petroleum gas up to 1" ID
- can be applied to many types of rubber, synthetic, plastic, metallic or semi-metallic hose, consult the factory for specific media capabilities

Features:

- positive Metal-to-Polymer Seal - a leakproof seal is formed when the metal head of the stem makes contact with the patented polymer seat in the spud.
- The non-metallic polymer seat resists most chemicals found in manufacturing facilities (reference the Corrosion Resistance chart in the Dixon Price List or on the web at www.dixonvalve.com/resources/cr_chart.php)
- recommended for steam service up to 450°F
- easy to seal
- works with existing ground joint fittings
- use with Boss clamps on page 23

**SAFETY
ALERT**

Materials:

- stems: ¼" - 1" plated steel, 1¼" - 4" plated iron, 6" tubular steel
- spuds: ¼" - 1" plated steel, 1¼" - 6" plated iron
- wing nuts: ¼" - 1" plated steel, 1¼" - 6" plated iron

Sizes:

- Available in ¼", 3/8", ½", ¾", 1", 1¼", 1½", 2", 2½", 3", 4" and 6"

Boss Male Stems



brass



iron



steel bar stock



316 stainless

Features:

- use with Boss clamps on page 23.

Materials:

- steel bar stock, iron, 316 stainless steel, brass

Sizes:

- ¼", 3/8", ½", ¾", and 1" available in steel bar stock
- 1¼", 1½", 2", 2½", 3" and 4" available in iron
- ½", ¾", 1", 1¼", 1½", 2", 2½", 3" and 4" available in 316 stainless steel
- ¾", 1", 1¼", 1½", 2" and 3" available in brass

Boss Clamps

Widely used for air, water, fluid, petroleum, steam, chemicals and liquid petroleum

Features:

- The bolts used in the Boss interlocking clamps are not standard bolts. They vary from standard bolts in their length, diameter, overall thread length and material hardness.

These bolts can be retorqued, but it is **not** recommended that the bolts or clamps be reused, as they are designed for a single bend only. Dixon recommends using only factory supplied replacement bolts.

SAFETY
ALERT

- Torque values for clamps are based on dry bolts. The use of lubricant on bolts will adversely effect clamp performance.
- do not lubricate nuts and bolts
- refer to page 26-27 for installation and inspection procedures
- replacement nuts and bolts are available, contact the factory for more information

SAFETY
ALERT

Materials:

- plated iron, stainless steel, brass, investment cast carbon steel

Sizes:

- 1/4", 3/8", 1/2", 3/4", 1", 1 1/4", 1 1/2", 2", 2 1/2", 3", 4" and 6" available in plated iron
- 1/2", 3/4", 1", 1 1/4", 1 1/2", 2" and 3" available in stainless steel
- 1/2", 3/4", 1", 1 1/4", 1 1/2", and 2" available in brass

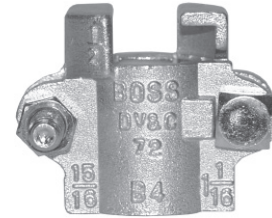

2-bolt type

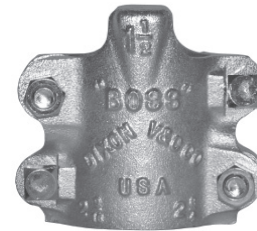

4-bolt type
2 gripping fingers

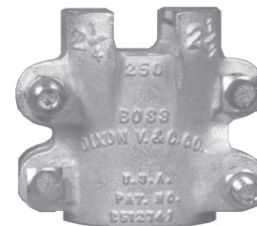

4-bolt type
4 gripping fingers



6-bolt type
three piece

Oilfield Accessory Products

Additional accessory products offered by Dixon

King Safety Cables

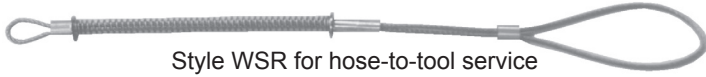

Style WSR for hose-to-tool service



Style W for hose-to-hose service

Service:

- When hose, couplings or clamps fail, or there is an accidental separation of the assembly, King safety cables minimize injuries to operators and damage to equipment. King safety cables reach across the hose fittings to provide standby safety for hose.

Styles:

- WSR for hose-to-tool service; W for hose-to-hose service; other cable options are available, contact the factory for additional information

Materials:

- steel, stainless steel

Gauges



brass liquid-filled



stainless liquid-filled



stainless panel builder



FlutterGuard™ dry

Service:

- Applications include those on pumps, hydraulic and pneumatic systems, compressors, machine tools and many other installations where it is necessary to have a gauge with a non-corrosive movement.

Styles:

- dry, contractor pressure, liquid filled, compound, welding, panel builder and vacuum gauges

Materials:

- stainless steel, brass, ABS plastic cases

Filters, Regulators and Lubricators



Series 1 - coalescing filter



Wilkerson -high flow regulator



Watts - standard lubricator

Service:

- rugged, reliable air preparation systems protect your pneumatic equipment

Styles:

- compact, standard and miniature

Straub Couplings

Joins like or dissimilar pipe materials: steel, galvanized, painted, stainless steel, thin-wall stainless steel, PVC, copper

Grip-L Pipe to Pipe Couplings

Service:

- not for steam or refrigerant service



Features:

- Requires no special tools or pipe-end preparation; only a torque wrench is required for a secure and safe pipe connection that seldom needs retightening. Reusable.
- absorbs vibration, water hammer, and sound
- particularly suitable for pipes within the lower pressure range
- special patented grip ring for superior holding power on hard-surfaced pipes
- built to ASTM 1476, Type 2, Class 2 specifications
- Applications include, but are not limited to: shipbuilding, water and waste water treatment plants, and industrial process pipework.

Specifications:

- casing: AISI 316Ti
- screws: AISI 316 L
- U-bolts: AISI 316 Ti
- anchoring ring: AISI 301
- EPDM sealing sleeve: temp. range - 4°F to 176°F (-20°C to 80°C)

Materials:

- component parts: 316 Ti stainless steel, *elastomer liner*
- sealing sleeve: EPDM standard (NBR and Viton®A are also available, contact the factory for additional information)

Sizes:

- available in ¾", 1", 1½", 2", 2½", 3", 4", 5", 6" and 8"



Open-Flex 1L Couplings

Service:

- not pull-out resistant



Features:

- Requires no special tools or pipe-end preparation; only a torque wrench is required for a secure and safe pipe connection that seldom needs retightening.
- Straub Open-Flex couplings do *require the pipes to be properly anchored and restrained* as they are *not pull-out resistant* like the Straub Grip-L couplings
- absorbs vibration, water hammer, and sound
- built to ASTM 1476, Type 2, Class 3 specifications
- acts as an expansion joint; will accept up to .25" of axial movement

Specifications:

- casing: AISI 316Ti
- screws: AISI 4135 steel
- bolts: AISI 12L 14 galvanized
- EPDM sealing sleeve: temp. range - 4°F to 176°F (-20°C to 80°C)

Materials:

- component parts: 316 Ti stainless steel, 4135 steel, 12L 14 galvanized
- sealing sleeve: EPDM

Sizes:

- available in 1½", 2", 2½", 3", 4", 5" and 6"

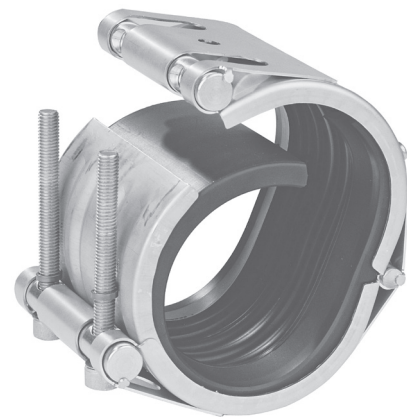

PROCEDURES

Procedure 1000

Boss Clamp Selection

1. Measure the hose ID (Inside Diameter).
 2. Measure the hose free OD (Outside Diameter) with a diameter tape. Free OD is measured before the stem is inserted.
 3. On the Boss clamp page in the Boss couplings section of the current DPL (Dixon Price List) locate the Hose ID column.
 4. Locate the section in that column that corresponds with the hose ID.
 5. From that section, select the clamp with a hose OD range (Hose OD From/To columns) that best fits the hose OD just measured.
 - a. For steam hose, select the clamp that has a maximum range (To column) as close to the measured hose O.D. as possible. This will allow the clamp to be re-tightened many times to adjust for Cold-Flow which speeds up with increased temperature and/or hot/cold cycles.
 - b. For hard wall constructed hose (wire present) with an OD at or near the clamp's maximum range (To column), use of the next largest clamp may be required.
 - c. For soft wall constructed hose (no wire present) having an OD at or near the clamp's minimum range (From column), use of the next smallest clamp may be required. Select the proper clamp based on material requirements.
 6. Select the proper clamp material based on the environmental compatibility requirements.
-

Procedure 2000

Installation of Boss 2-Bolt Clamp

1. Insert shank into hose.
 2. Place the stem in a vise:
 - a. For male stems, tighten the vise on the hex.
 - b. For female stems (wing nut), place a spud in the vise, tighten, and then thread the wing nut onto the spud.
 3. Position the clamp gripping fingers behind the stem collar.
 4. Tighten the bolts by hand until there is equal thread engagement. When hose OD is at or near clamp maximum range, starting of nuts on bolts may require squeezing clamp halves in a vise.
 5. Using a torque wrench tighten bolts to the recommended torque value listed in the current DPL. Torque values are based upon "dry bolts". Lubricant on bolts will adversely effect clamp performance.

Bolt tightening sequence:

 - a. Front bolt, 1 full turn.
 - b. Opposite side front bolt, 1 full turn.
 - c. Repeat "a" and "b" until all bolts are tightened. Clamp bolts are designed to bend during tightening. This "bending" allows the clamp to conform to the hose circumference.
 6. Inspect results using Procedure 3000 (Criteria for Sufficient Fit of a Boss Clamp) and Procedure 3001 (Bolt Clamp Inspection).
 7. Test assembly using Procedure 4000 (General Hydrostatic Testing Information) and 4001 (Hydrostatic Testing Procedure).
-

Procedure 2001

Installation of Boss 4-Bolt Clamp

1. Insert shank into hose.
2. Place the stem in a vise:
 - a. For male stems, tighten the vise on the hex.
 - b. For female stems (wing nut), place a spud in the vise, tighten, and then thread the wing nut onto the spud.
3. Position the clamp gripping fingers behind the stem collar.
4. Tighten the bolts by hand until there is equal thread engagement. When hose OD is at or near clamp maximum range, starting of nuts on bolts may require squeezing clamp halves in a vise.
5. Using a torque wrench tighten bolts to the recommended torque value listed in the current DPL. Torque values are based upon "dry bolts". Lubricant on bolts will adversely effect clamp performance. Bolt tightening sequence:
 - a. Back bolt, 1 full turn.
 - b. Front bolt, 1 full turn.
 - c. Snug by hand, nuts on opposite side of bolts just tightened.
 - d. Opposite side back bolt, 1 full turn.
 - e. Opposite side front bolt, 1 full turn.
 - f. Snug by hand, nuts on opposite side of bolts just tightened.
 - g. Repeat "a" to "f" until all bolts are tightened. Clamp bolts are designed to bend during tightening. This "bending" allows the clamp to conform to the hose circumference.
6. Inspect results using Procedure 3000 (Criteria for Sufficient Fit of a Boss Clamp) and Procedure 3001 (Bolt Clamp Inspection).
7. Test assembly using Procedure 4000 (General Hydrostatic Testing Information) and 4001 (Hydrostatic Testing).

*Installation and Inspection procedures may be viewed in full on the Dixon website, www.dixonvalve.com.
A printed copy of the complete Installation and Inspection Procedures Manual is available upon request.*

*Procedure 3000***Criteria for Sufficient Fit of a Boss Clamp**Minimum Range

1. 1/32" clearance between clamp halves (both sides) for clamps designed to fit 1/4" ID through 2" ID hose.
2. 1/16" clearance between clamp halves (both sides for 4 bolt clamps) or all segments (6 bolt clamps) for clamps designed to fit 2-1/2" ID through 6" ID hose.
3. 1/32" clearance between clamp gripping fingers (all gripping fingers) and stem groove for all sizes.

Maximum Range

1. 1/32" interlock between clamp gripping finger and stem collar (all gripping fingers) for clamps designed to fit 1/4" ID - 2" ID hose.
2. 1/16" interlock between clamp gripping finger and stem collar (all gripping fingers) for clamps designed to fit 2-1/2" ID - 6" ID hose.
3. 1/32" interlock between dovetail extensions (both sides) for clamps designed to fit 1/4" ID through 2" ID hose.
4. 1/16" interlock between dovetail extensions on both sides (4 bolt clamps) or all segments (6 bolt clamps) for clamps designed to fit 2-1/2" ID through 6" ID hose.

*Procedure 3001***Bolt Clamp Inspection**All Bolt Clamps

1. Prior to initial use, check to ensure that the clamp is appropriate for the hose and application.
2. Prior to initial use and at scheduled subsequent inspections, ensure that each clamp has its full complement of nuts and bolts. If any are missing, call an authorized Dixon distributor or Dixon at 1-800-355-1991. Replacing clamp nuts and bolts with other than those supplied by Dixon could adversely affect the function of the clamp.
3. Prior to use after storage, tighten all bolts to their recommended torque rating. Use the tightening sequence recommended in the appropriate Dixon Procedure. Over tightening nuts can damage the bolt and /or clamp and affect its function.
4. For assemblies that are in constant service (connected whether product is being conveyed or not), retighten all bolts to their recommended torque rating every month. *Note: Do not tighten bolts while assembly is pressurized.*
5. Prior to initial use of the assembly, spray paint the junction of the hose and coupling. *Note: Use a paint color that contrasts with the color of the coupling and the hose cover. Do not use silver paint.*
6. Look for slippage between the hose and coupling prior to each use, during use and at each scheduled inspection. If 1/16" or more slippage has occurred or occurs, repair the assembly. *Note: If slippage has occurred, inspect the hose to determine suitability for returning it to service. Follow hose manufacturer's recommendations for determining hose serviceability. Note: Some hoses exhibit "stretch" while under pressure. This stretch may appear to be slippage. To be certain, relieve the pressure in the assembly. If the "slippage" indication disappears, stretch has occurred and the assembly can be returned to service. If the "slippage" indication does not disappear, the assembly should be removed from service for repair or replacement.*

Bolt Clamps without Gripping Fingers

1. Prior to each use or at each inspection interval, inspect:
 - a. Bolt lugs for cracks.
 - b. Bolt lugs for excessive wear (worn down to bolt hole).
 - c. Clamp bodies for cracks.
 - d. Clamp bodies for excessive wear. (Example: Lettering detail "Dixon" worn off.)
 - e. For inadequate spacing between clamp halves (on clamps without saddles).
 - f. For inadequate spacing between clamp halves and the saddle loop (on clamps with saddles).
2. If any of the above conditions exist, do not place assembly in service or remove assembly from service.

Bolt Clamps with Gripping Fingers

1. Prior to each use or at each inspection interval, inspect:
 - a. Bolt lugs for cracks.
 - b. Bolt lugs for excessive wear (worn down to bolt hole).
 - c. Junction of bolt lugs and clamp body for cracks.
 - d. Clamp body for cracks.
 - e. Clamp body for excessive wear. (Example: Lettering detail "Dixon" worn off.)
 - f. Gripping fingers for cracks.
 - g. Missing gripping fingers.
 - h. For adequate spacing between clamp halves.
 - i. For adequate spacing between the end of gripping fingers and the stem in the groove behind the collar.
2. If any of the above conditions exist, do not place assembly in service or remove assembly from service.

*Installation and Inspection procedures may be viewed in full on the Dixon website, www.dixonvalve.com.
A printed copy of the complete Installation and Inspection Procedures Manual is available upon request.*

Dixon, 877.963.4966

Through its divisions and affiliated companies, Dixon is recognized as the premier manufacturer and supplier of hose fittings and accessories spanning a wide range of industrial uses. Dixon's reach includes products for fire protection, food, dairy processing, beverage and brewery, mobile tankers, mining, construction, chemical processing, petroleum, oilfields, refining and manufacturing.



The Right Connection™

Dixon Valve & Coupling Company

800 High Street, Chestertown, MD 21620

Customer Service: 877.963.4966

Fax: 800.283.4966

www.dixonvalve.com