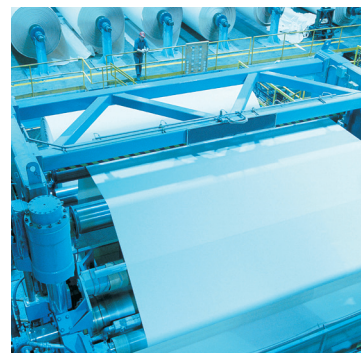


# Pneumatic Actuator Products

Cylinders, Guided Cylinders and Rotary Actuators

Catalog 0900P-6



ENGINEERING YOUR SUCCESS.

[www.comoso.com](http://www.comoso.com)

**Warning, Offer of Sale**

---

 **WARNING**

FAILURE OR IMPROPER SELECTION OR IMPROPER USE OF THE PRODUCTS AND/OR SYSTEMS DESCRIBED HEREIN OR RELATED ITEMS CAN CAUSE DEATH, PERSONAL INJURY AND PROPERTY DAMAGE.

This document and other information from Parker Hannifin Corporation, its subsidiaries and authorized distributors provide product and/or system options for further investigation by users having technical expertise. It is important that you analyze all aspects of your application including consequences of any failure, and review the information concerning the product or system in the current product catalog. Due to the variety of operating conditions and applications for these products or systems, the user, through its own analysis and testing, is solely responsible for making the final selection of the products and systems and assuring that all performance, safety and warning requirements of the application are met.

The products described herein, including without limitation, product features, specifications, designs, availability and pricing, are subject to change by Parker Hannifin Corporation and its subsidiaries at any time without notice.

**Offer of Sale**

The items described in this document are hereby offered for sale by Parker Hannifin Corporation, its subsidiaries or its authorized distributors. This offer and its acceptance are governed by the provisions stated on the separate page of this document entitled "Offer of Sale".

© Copyright 2016, 2011, 2009, 2008 Parker Hannifin Corporation. All Rights Reserved



<b>Product Index, Application Engineering Data</b>		<b>A</b> Product Index Engineering Data
<b>Tie Rod Cylinders</b>	<i>4MA/4ML Series, 4MAJ Series, 2MNR Series, ACVB Option, LPSO Option, P1D Series</i>	<b>B</b> Tie Rod Cylinders
<b>Round Body Cylinders</b>	<i>SR/SRM Series, SRD/SRDM Series, SRG/SRGM Series, SRX Series, P1A Series, P Series</i>	<b>C</b> Round Body Cylinders
<b>Compact Cylinders</b>	<i>P1Q Series, LP/LPM Series</i>	<b>D</b> Compact Cylinders
<b>Guided Cylinders</b>	<i>P5T Series, P5L Series, HB Series, P5E Series, XL Series</i>	<b>E</b> Guided Cylinders
<b>Automation Products</b>	<i>Grippers, Slide Tables, Rotary Tables, Escapements</i>	<b>F</b> Automation Products
<b>Rodless Cylinders</b>	<i>OSP-P, P1X Series, P1Z Series, GDL Series</i>	<b>G</b> Rodless Cylinders
<b>Rotary Actuators</b>	<i>PV Series, PRNA/PRN Series, PTR Series, B671/F672 Series, HP Series</i>	<b>H</b> Rotary Actuators
<b>Air Motors</b>	<i>P1V-S Series</i>	<b>J</b> Air Motors
<b>Actuator Accessories</b>	<i>Linear Alignment Couplers, Flow Controls, 4TK Air Oil Tanks, PRL Series</i>	<b>K</b> Actuator Accessories
<b>Electronic Sensors</b>	<i>Solid State, Reed and Proximity Sensors</i>	<b>L</b> Electronic Sensors
<b>Industrial Shock Absorbers</b>	<i>Industrial Shock Absorbers (Linear Decelerators)</i>	<b>M</b> Industrial Shock Absorbers
<b>Fax Forms, Part Number Index, Safety Guide, Offer of Sale</b>	<i>Application FAX Forms</i>	<b>N</b> Fax Forms, Safety Guide, Offer of Sale



For inventory, lead time, and kit lookup, visit [www.pdnplu.com](http://www.pdnplu.com)

**A**

Product Index,  
 Engineering Data

Product  
 Index

Engineering  
 Data

## Tie Rod Cylinders

### 4MA / 4ML Series - Flexible NFPA Cylinder



B2

- Bore sizes 1-1/2 through 8 inch
- 20 standard mounting styles
- Pressures up to 250 PSIG
- Temperatures -50°F to 250°F
- Aluminum body construction

### 4MAJ - Rodlock Cylinder



B37

- Bore sizes 1-1/2 through 8 inch
- 17 standard mounting styles
- Pressures up to 100 PSIG
- Temperatures -10°F to 165°F
- Aluminum body construction

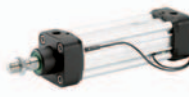
### 2MNR Series - Non-Rotating



B92

- Bore sizes 1-1/2 through 4 inch
- 9 standard mounting styles
- Pressures up to 250 PSIG
- Temperatures -10°F to 165°F
- Non-rotating, multi-rod design

### P1D Series - ISO 15552 / ISO 6431



B104

- 5 available for maximum flexibility
- Bore sizes 32mm through 200mm
- 10 standard mounting styles
- Pressures up to 145 PSIG
- Temperatures -10°F to 250°F
- Aluminum body construction

## Round Body Cylinders

### SR / SRM / SRD / SRDM Series - Non-Repairable



C2

- Bore sizes 5/16 through 3 inch
- 28 mounting styles
- Pressures up to 250 PSIG
- Temperatures -10°F to 165°F
- Stainless steel body construction

### SRG / SRGM Series - Stainless Caps



C34

- Bore sizes 1-1/16 through 3 inch
- Continuous position feedback
- Pressures up to 150 PSIG
- Temperatures 40°F to 165°F
- Stainless steel body construction

### SRX Series - Position Feedback



C38

- Bore sizes 1-1/16 through 3 inch
- Continuous position feedback
- Pressures up to 150 PSIG
- Temperatures 40°F to 165°F
- Stainless steel body construction

### P1A Series - ISO Non-Repairable



C50

- Bore sizes 10mm through 25mm
- 5 mounting styles
- Pressures up to 145 PSIG
- Temperatures -40°F to 302°F
- Stainless steel body construction

### P Series - Repairable



C58

- Bore sizes 1-1/8 through 4 inch
- 4 mounting styles
- Pressures up to 150 PSIG
- Temperatures -10°F to 250°F
- Aluminum body construction

## Compact Cylinders

### P1Q Series - Economy Compact Cylinder



D2

- Bore sizes 12mm through 100mm
- 4 flexible mounting options
- Pressures up to 10 PSIG
- Temperatures 23°F to 158°F
- Aluminum body construction

## Guided Cylinders

### P5T Series - Compact Guided



E2

- Bore sizes 16mm through 100mm
- Pressures up to 145 PSIG
- Temperatures 0°F to 250°F
- Aluminum body construction
- Flexible porting: top, rear, side

### LP / LPM Series - Compact Cylinder



D10

- Bore sizes 9/16 through 4 inch
- 6 mounting styles
- Pressures up to 150 PSIG
- Temperatures -10°F to 200°F
- Aluminum body construction

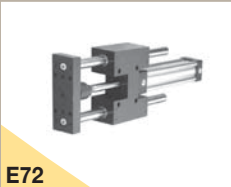
### P5L Series - Guided



E22

- Bore sizes 20mm through 100mm
- Thrust, Reach and Base version available
- Direct mounting
- Pressures up to 145 PSIG
- Temperatures 0°F to 250°F
- Extruded aluminum body construction

### HB Series - Heavy Duty Guided



E72

- Bore sizes 1-1/2 through 2-1/2 inch
- Thrust, reach and compact versions available
- Air service pressure up to 250 PSIG, hydraulic service up to 750 PSIG
- Temperatures 0°F to 250°F
- Aluminum body construction
- Rod lock version available

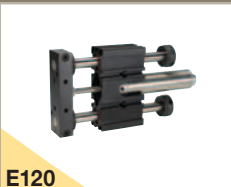
### P5E Series - P1D ISO Guided



E104

- Bore sizes 32mm through 100mm
- Pressures up to 145 PSIG
- Temperatures 14°F to 165°F
- Aluminum body construction
- Rod lock version available

### XL Series - Slide / Glided



E120

- Bore sizes 9/16 through 1-1/2
- Thrust, Reach and Base version available
- Lightweight body

**A**

Product Index,  
 Engineering Data

Product  
 Index

Engineering  
 Data

## Automation Products

### Economy Grippers



F2

- Cost effective solution for machine builders
- Angular and Parallel
- 12mm to 32mm bore

### Precision Grippers



F98

- Premium product for precision and durability
- Repeatability to + 0.00005mm
- Parallel 2 and 3 jaw
- Strokes to 73.5mm
- Grip forces to 44,000 N
- Clean room
- Electric grippers

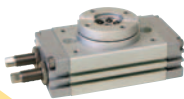
### Slide Tables



F116

- Built in linear rail
- Bore size 6-25mm
- Available with stroke adjusters and shock absorbers

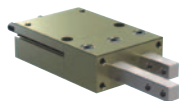
### Rotary Tables



F130

- Twin rack and pinion rotary with integrated table
- Rotation adjustment standard 0-190 degrees
- Available with shock absorbers
- Hollow shaft standard for wiring and piping

### Escapement

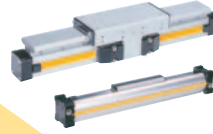


F130

- Most effective mechanism for separating parts fed from conveyor
- Thrust force to 400 N
- Adjustable retract

## Rodless Cylinders

### OSP-P Series - Band Type Rodless



G2

- Bore sizes 10mm through 80mm
- Pressures to max. 8 bar
- Temperatures -10°F to 80°F
- Aluminum body construction

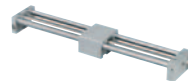
### P1X Series - Band Type Rodless



G98

- 7 bore sizes 16mm through 63mm
- Integral sensor mounting rail
- Pressures 7 to 100 PSIG
- Temperatures 40°F to 140°F
- Aluminum body construction

### P1Z Series - Magnetically Coupled Rodless



G116

- 3 bore sizes 16mm, 20mm & 32mm
- Pressures 29 to 100 PSIG
- Temperatures 15°F to 140°F
- Stainless steel body construction

### GDL Series - Rails & Cassettes



G130

- 6 sizes available
- Speed up to 10m/s (33 ft/s)
- Temperatures -10°C to 80°C
- Aluminum alloy rail
- Aluminum body construction

## Rotary Actuators

### PV Series - Vane Rotary



H3

- 8 model sizes
- Single or double vane models
- Pressures to 150 PSIG
- Temperatures 30°F to 250°F
- 7 to 1800 lb-in output torque

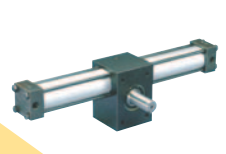
### PRN(A) Series - Vane Rotary



H11

- 5 miniature and 4 standard models
- Temperatures -23°F to 176°F
- 1.33 to 2355 in-lb torque at 100 PSIG

### PTR Series - Rack & Pinion Rotary



H23

- Bore sizes 1 through 3-1/4 inch
- Pressures to 250 PSIG
- Temperatures 0°F to 250°F
- 39 to 2281 lb-in output torque

### B671/F672 Series - Rack & Pinion Rotary



H38

- 

### HP Series - Large Rack & Pinion Rotary

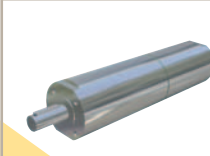


H42

- 2 large bore models
- 3 standard rotations
- Pressures to 100 PSIG
- Temperatures 0°F to 250°F
- 4500 and 10,000 lb-in output at 100 PSIG

## Air Motors

### P1V-S Series - Air Motors

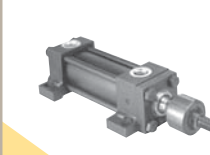


J2

- Power from 20 through 1200 watts
- Speeds 5 to 24,000 RPM
- Pressures to max. 7 bar
- Temperatures -30°C to 100°C

## Actuator Accessories

### Linear Alignment Couplers



K2

- 12 standard thread sizes
- Maximum reliability for trouble-free operation, long life and lower operating costs
- Increased cylinder life by reducing wear on piston and rod bearings
- Stainless steel versions available

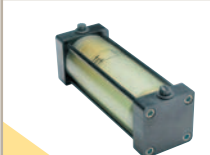
### Flow Controls



K3

- 9 brass right angle flow controls
- 12 blocking valves
- 8 Miniature exhaust flow control valves
- Numerous male global connect fittings and port adapters
- Male and female NPT threaded ports
- Prestolok fittings also available

### 4TK Series - Air Oil Tanks



K6

- 6 standard bore sizes
- Lightweight aluminum / fiberglass design
- 2 fluid flow baffles reduce agitation and aeration
- 8 standard mounting styles

### PRL Series - Stand Alone Rodlock



K9

- 5 different sizes
- Large holding forces
- 2 different mounting styles
- Case-hardened rod material available

**A**

Product Index,  
Engineering Data

Product  
Index

Engineering  
Data

## Electronic Sensors

### Sensors



- Solid state
- Reed
- NAMUR
- Proximity

L1

## Fax Forms, Part Number Index, Safety Guides, Offer of Sale

- Fax Forms
- Part Number to Page Number Index
- Safety Guide – Actuator Products
- Offer of Sale

N1

## Shock Absorbers

### Shock Absorbers



- Miniature - self-compensating
- Heavyweight - soft contact & self-compensating
- Miniature - soft contact & self-compensating
- Magnum series - adjustable
- Heavy - self-compensating
- Heavy - adjustable

M1



For inventory, lead times, and kit lookup, visit [www.pdnplu.com](http://www.pdnplu.com)



# PNEUMATIC DIVISION E-TOOLS

## Pneumatic Division Part Lookup Tool

### Part Lookup Tool Overview

The purpose of this application is to provide users with more in depth detail, such as replacement kits or current inventory for specific pneumatic part numbers. The tool also provides cross reference information for products that have been previously obsoleted. Searches can be made by searching a portion or all of a part number. Use the drop down options available to narrow your search.



### Part Lookup Tool Contents

- Replacement KITS by part number
- Obsolete cross reference
- Inventory/stock levels
- Pricing (with distributor login only)
- Bulk part search
- Shipping location
- Lead time

### How to access the Tool

U.S. Parker Pneumatic Distributors

- [www.pdnpartlookup.com](http://www.pdnpartlookup.com)
- Or download the “Distributor Toolbox” app



Guest Users

- [www.pdnplu.com](http://www.pdnplu.com)

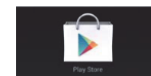
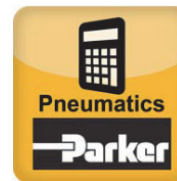
## Pneumatic Division Size & Selection Calculators

### Size, Selection and Cost of Air Calculators Overview

The purpose of this application is to provide users and designers of pneumatic systems with a handy collection of compressed air cost calculators, conversion tools and air valve (Cv) and flow (SCFM) calculations for air cylinder actuation. The size and select calculators are available to anyone for use. See details below.

### How to access the Tool

- [www.parkerpdncalc.com](http://www.parkerpdncalc.com)
- Or download the “Pneumatics” calculator app



### Calculator Contents

- Cost calculator for leaks
- Cost calculator for compressors
- Cost calculator for reverse flow regulators
- Vacuum flow through an orifice
- Air flow through an orifice
- Annual cost of air cylinder operation
- Valve/FRL sizing for cylinder actuation
- And more!



For inventory, lead time, and kit lookup, visit [www.pdnplu.com](http://www.pdnplu.com)

**A**

Product Index,  
Engineering Data

Product  
Index

Engineering  
Data

# The Parker 5-Year Extended Warranty

**P**arker Hannifin Corporation will extend its warranty on all pneumatic components to sixty (60) months providing they are correctly installed and protected by Parker pneumatic filters which are properly maintained. Components covered by this warranty include all cylinders, valves and pneumatic automation components manufactured by Parker in any of our global facilities. This warranty covers our components anywhere in the world you may ship your equipment.

Parker's obligation under this warranty is limited to the replacement or repair of any failed components. The buyer understands that the seller will not be liable for any other costs or damages.

The buyers of quality Parker components and filters benefit by having ONE source for all pneumatic needs - **Parker**.



*Yoon Chung*  
Yoon "Michael" Chung  
President  
Automation Group



For inventory, lead times, and kit lookup, visit [www.pdnplu.com](http://www.pdnplu.com)

## Application Engineering Data

<b>Product Selection Guide</b>	A2-A3
<b>Engineering Data</b>	
Fluids, Temperature Range and Warranty	A4
Operating Principles and Construction	A5
Push and Pull Forces	A6
Mounting Information	
Straight Line Force Transfer (Group 1)	A7
Straight Line Force Transfer (Group 3)	A8
Pivot Force Transfer (Group 2)	A9
Accessories	
Removable Trunnion Pins	A10
Ports	A11
Stroke Data & Adjusters – Tie Rod Supports	A12
Stop Tubing & Mounting Classes	A13
Stroke Selection Chart	A14
Deceleration Forces and Air Requirements	A15
Cushion Rating and Air Requirements	A16
Air Requirements	A17-A18
NFPA Rod End Data & Piston Rods	A19
Modifications, Special Assemblies, Tandem	A20
Rotary Actuator	
Torque Requirements	A21-A23
Moments of Inertia	A24
Basic Equations	A25
Conversion Factors	A26

**A**

Product Index,  
Engineering Data

Product  
Index

Engineering  
Data



For inventory, lead time, and kit lookup, visit [www.pdnplu.com](http://www.pdnplu.com)

**A**  
**Product Index, Engineering Data**  
**Product Index**  
**Engineering Data**

Catalog Section	Cylinder Series	Bore Size																										
		6mm	8mm	10mm	12mm	16mm	20mm	7/8"	1"	1-1/16"	1-1/8"	1-1/4"	1-1/2"	1-3/4"	2"	2-1/2"	3"	3-1/4"	3-5/8"	4"	4-1/2"	5"	6"	7"	8"	10"	12"	14"
B - Tie Rod	4MA											◆			◆	◆		◆	◆	◆	◆	◆	◆	◆	◆	◆		
	4MAJ Rodlock											◆			◆	◆		◆	◆	◆	◆	◆	◆	◆	◆	◆		
	ACVB Valve Option											◆			◆	◆		◆	◆	◆	◆	◆	◆	◆	◆	◆		
	P1D											■	■		■	■		■	■	■	■	■	■	■	■	■		
C - Round Body	SR		◆		◆	◆	◆	◆		◆		◆	◆	◆	◆	◆	◆											
	SRM					◆	◆			◆		◆	◆	◆	◆	◆												
	SRD					◆	◆			◆		◆	◆	◆	◆	◆												
	SRDM					◆	◆			◆		◆	◆	◆	◆	◆												
	SRG						◆			◆		◆	◆	◆	◆	◆												
	SRGM						◆			◆		◆	◆	◆	◆	◆												
	SRX									◆		◆	◆	◆	◆	◆	◆											
	P1A		■	■	■	■			■																			
	P									◆		◆	◆	◆	◆	◆					◆							
D - Compact	P1Q				■	■	■		■		■	■		■	■		■	■										
	LP					◆	◆			◆		◆	◆	◆	◆	◆				◆								
	LPM					◆	◆			◆		◆	◆	◆	◆	◆				◆								
F - Rodless	OSP-P		■		■			■			■	■		■	■		■											
	P1X				■	■		■			■	■		■	■													
	P1Z					■	■				■																	

- ◆ = Inch Bore Size
- = Metric Bore Size
- = Standard
- = Optional
- R = Required
- F = Fixed Cushions
- E = End of Stroke Only
- S = Special, Consult Factory



For inventory, lead times, and kit lookup, visit [www.pdnplu.com](http://www.pdnplu.com)

Construction	Cylinder Body Material	End Cap Material	# of Mountings	Pressure Range (PSI)	Single Acting	Double Acting	Adjustable Air Cushions	Flexible Porting Option	Piston Sensing Option	Cylinder Series	Catalog Section
NFPA	Aluminum	Aluminum	15	250	S	●	○		○	<b>4MA</b>	<b>B - Tie Rod</b>
NFPA	Aluminum	Aluminum	11	100	S	●	●		○	<b>4MAJ Rodlock</b>	
NFPA	N/A	N/A	17	145	N/A	N/A	N/A	N/A	N/A	<b>ACVB Valve Option</b>	
ISO/VDMA	Aluminum	Aluminum	10	145	S	●	○		●	<b>P1D</b>	<b>C - Round Body</b>
Non-repairable	Stainless Steel	Aluminum	28	250	●	●	○			<b>SR</b>	
Non-repairable	Stainless Steel	Aluminum	24	250	●	●	○		●	<b>SRM</b>	
Non-repairable	Stainless Steel	Acetal	2	100	S	●				<b>SRD</b>	
Non-repairable	Stainless Steel	Acetal	2	100	S	●			●	<b>SRDM</b>	
Non-repairable	Stainless Steel	Stainless Steel	2	250	N/A	●				<b>SRG</b>	
Non-repairable	Stainless Steel	Stainless Steel	2	250	N/A	●				<b>SRGM</b>	
Non-repairable	Stainless Steel	Aluminum	3	150		●			●	<b>SRX</b>	
Non-repairable	Stainless Steel	Aluminum	4	145	○	●	○		●	<b>P1A</b>	
Snap-Ring	Aluminum	Aluminum	4	150	○	●	○		○	<b>P</b>	
Extruded Aluminum Body-Compact	Aluminum	N/A	4	145	N/A	●				<b>P1Q</b>	<b>D - Compact</b>
Tie Rod Compact	Aluminum	Aluminum	6	250	○	●				<b>LP</b>	
Tie Rod Compact	Aluminum	Aluminum	6	250	○	●			●	<b>LPM</b>	
Band-Type	Aluminum	Aluminum	11	120			●	●	●	<b>OSP-P</b>	<b>F - Rodless</b>
Band-Type Rodless	Aluminum	Aluminum	5	100	N/A	●	●	●	●	<b>P1X</b>	
Magnetically Coupled Rodless	Aluminum	Aluminum	3	100		●	●	●	●	<b>P1Z</b>	

- ◆ = Inch Bore Size
- = Metric Bore Size
- = Standard
- = Optional
- R = Required
- F = Fixed Cushions
- E = End of Stroke Only
- S = Special, Consult Factory

A	Product Index, Engineering Data
Product Index	
Engineering Data	



For inventory, lead time, and kit lookup, visit [www.pdnplu.com](http://www.pdnplu.com)

**A**

**Product Index,  
Engineering Data**

**Product  
Index**

**Engineering  
Data**

**Operating Fluids and Temperature Range**

Fluidpower cylinders are designed for use with pressurized air, hydraulic oil and fire resistant fluids, in some cases special seals are required.

**Standard Seals (class 1)**

Class 1 seals are what is normally provided in a cylinder unless otherwise specified. They are intended for use with fluids such as: air, nitrogen, mineral base hydraulic oil or MIL-H-5606 within the temperature range of -10°F (-23°C) to 165°F (74°C). Generally they are nitrile except for piston rod seals in hydraulic cylinders. However the individual seals may be nitrile (Buna-N) enhanced polyurethane, polymyte, P.T.F.E. or filled P.T.F.E.

**Water Base Fluid Seals (class 2)**

Generally class 2 seals are intended for use with water base fluids within the temperature of -10°F (-23°C) to 165°F (74°C) except for High Water Content Fluids (H.W.C.F.) in which case Class 6 seals should be used. Typical water base fluids are: Water, Water-Glycol, Water-in Emulsion, Houghto-Safe 27, 620, 5040, Mobil Pyrogard D, Shell Iruis 905, Ucon Hydrolube J-4. These seals are nitrile. Lipseal will have polymyte or P.T.F.E. back-up washer when required. O-rings will have nitrile back-up washers when required.

**Ethylene Propylene (E.P.R.) Seals (class 3)**

Class 3 seals are intended for use with some Phosphate Ester Fluids between the temperatures of -10°F (-23°C) to 130°F (54°C). Typical fluids compatible with E.P.R. seals are Skydrol 500 and 700. E.P.R. are Ethylene Propylene. Lipseals will have a P.T.F.E. back-up washer when required. O-rings will have EPR back-up washers when required. Note: E.P.R. seals are not compatible with mineral base hydraulic oil or greases. Even limited exposure to these fluids will cause severe swelling. P.T.F.E. back-up washer may not be suitable when used in a radiation environment.

**Low Temperature Nitrile Seals (class 4)**

Class 4 seals are intended for low temperature service with the same type of fluids as used with Class 1 seals within the temperature range of -50°F (-46°C) to 150°F (66°C). Lipseals will have leather, polymyte or P.T.F.E. back-up washers when required. O-rings will have nitrile back-up washers when required.

**Fluorocarbon Seals (class 5)**

Class 5 seals are intended for elevated temperature service or for some Phosphate Ester Fluids such as Houghto-Safe 1010, 1055, 1120; Fyrquel 150, 220, 300, 350; Mobile Pyrogard 42, 43, 53, and 55. Note: In addition, class 5 seals can be used with fluids listed below under standard service. However, they are not compatible with Phosphate Ester Fluids such as Skydrols. Class 5 seals can operate with a temperature range of -10°F (-23°C) to 250°F (121°C). Class 5 seals may be operated to 400°F (204°C) with limited service life, but please consult [the pdnapps@parker.com](mailto:pdnapps@parker.com) for possible cylinder material changes. For temperatures above 250°F (120°C) the cylinder must be manufactured with non-studded piston rod and thread and a pinned piston to rod

connection. Class 5 Lipseals will have P.T.F.E. back-up washers when required. O-rings will have fluorocarbon back-up when required.

**Warning**

The piston rod stud and the piston rod to piston threaded connections are secured with an anaerobic adhesive which is temperature sensitive. Cylinders specified with Class 5 seals are assembled with anaerobic adhesive having a maximum temperature rating of 250°F (74°C). Cylinders specified with all other seal compounds are assembled with anaerobic adhesive having a maximum operating temperature rating 165°F (74°C). These temperature limitations are necessary to prevent the possible loosening of the threaded connections. Cylinders originally manufactured with class 1 seals (Nitrile) that will be exposed to ambient temperatures above 165°F (74°C) must be modified for higher temperature service. Contact the factory immediately and arrange for the piston to rod and the stud to piston rod connections to be properly re-assembled to withstand the higher temperature service.

**Lipseal Pistons**

Under most conditions lipseals provide the best all around service for pneumatic applications. Lipseals with a back-up washer are often used for hydraulic applications when virtually zero static leakage is required. Lipseals will function properly in these applications when used in conjunction with moderate hydraulic pressures.

**Water Service**

For pressures up to 400 PSIG, 4ML series cylinders can be modified to make them more suitable for use with water as the operating medium. Chrome plated 17-4 PH stainless steel piston rod is recommended to inhibit corrosion.

**Warranty**

Parker Hannifin will warrant cylinders modified for water or high water content fluid service to be free of defects in materials or workmanship, but cannot accept responsibility to premature failure due to excessive wear due to lack of lubricity or where failure is caused by corrosion, electrolysis or mineral deposits within the cylinder.

**Non-Lubricated Air Cylinders**

Cylinder series rated "Non-Lube" (such as 4MA, P1D, P1L, 2AN, etc.) are recommended for non-lubricated air service. These cylinders are originally lubricated at the factory and typically do not require any additional lubrication for most applications. Please note that the use of air-line oil lubricators will wash away the original grease lubricant, so it must be continued until the cylinder is serviced with the appropriate grease lubricant.

Many of the terms and drawings in this Engineering Section (such as mounting styles) utilize 2A or 4MA Series cylinders as examples. Although the terms, designs and drawings for other product series may be different, many basic principles apply. Please refer to these individual product sections in this catalog for additional information.

Class No.	Typical Fluids	Temperature Range
1 (Standard) (Nitrile Polyurethane)	Air, Nitrogen, Hydraulic Oil, Mil-H-5606 Oil	-10°F (-23°C) to 165°F (74°C)
2 Optional Water Base Fluid Seal	Water, Water-Glycol, Water-in-Oil Emulsion Houghto-Safe, 271, 620, 5040 Mobil Pyrogard D, Shell Iruis 905 Ucon Hydrolube J-4	-10°F (-23°C) to 165°F (74°C)
3 Special (E.P.R.) (At extra cost) Note: (E.P.R.) seals are not compatible with Hydraulic Oil	Some Phosphate Ester Fluids Skydrol 500, 7000	-10°F (-23°C) to 130°F (54°C)
4 Special (Nitrile) (At extra cost)	Low Temperature Air or Hydraulic Oil	-50°F (-46°C) to 150°F (66°C)
5 Optional (At extra cost) (Fluorocarbon Seals)	High Temperature Houghto-Safe 1010, 1055, 1120 Fyrquel 150, 220, 300, 550 Mobil Pyrogard 42,43,53,55	See above paragraph on fluorocarbon seals for recommended temperature range.

Note: Fluorocarbon seals are not suitable for use with Skydrol fluid, but can be used with hydraulic oil if desired



For inventory, lead times, and kit lookup, visit [www.pdnplu.com](http://www.pdnplu.com)

**Fundamental Cylinders**

**Standard Double-Acting Cylinders**

Power stroke is in both directions and is used in the majority of applications.

**Single-Acting Cylinders**

When thrust is in only one direction, a single-acting cylinder may be used. The inactive end is vented to atmosphere through a breather/filter for pneumatic applications, or vented to reservoir below the oil level in hydraulic application.

**Double-Rod Cylinders**

Used when equal displacement is needed on both sides of the piston, or when it is mechanically advantageous to couple a load to each end. The extra end can be used to mount cams for operating limit switches, etc.

**Spring Return, Single-Acting Cylinders**

Usually limited to very small, short stroke cylinders used for holding and clamping. The length needed to contain the return spring makes them undesirable when a long stroke is needed.

**Ram Type, Single-Acting Cylinders**

Containing only one fluid chamber, this type of cylinder is usually mounted vertically. The weight of the load retracts the cylinder. They are sometimes know as “displacement cylinders”, and are practical for long strokes.

**Telescoping Cylinders**

Available with up to 4 or 5 sleeves; collapsed length is shorter than standard cylinders. Available either single or double-acting, they are relatively expensive compared to standard cylinders.

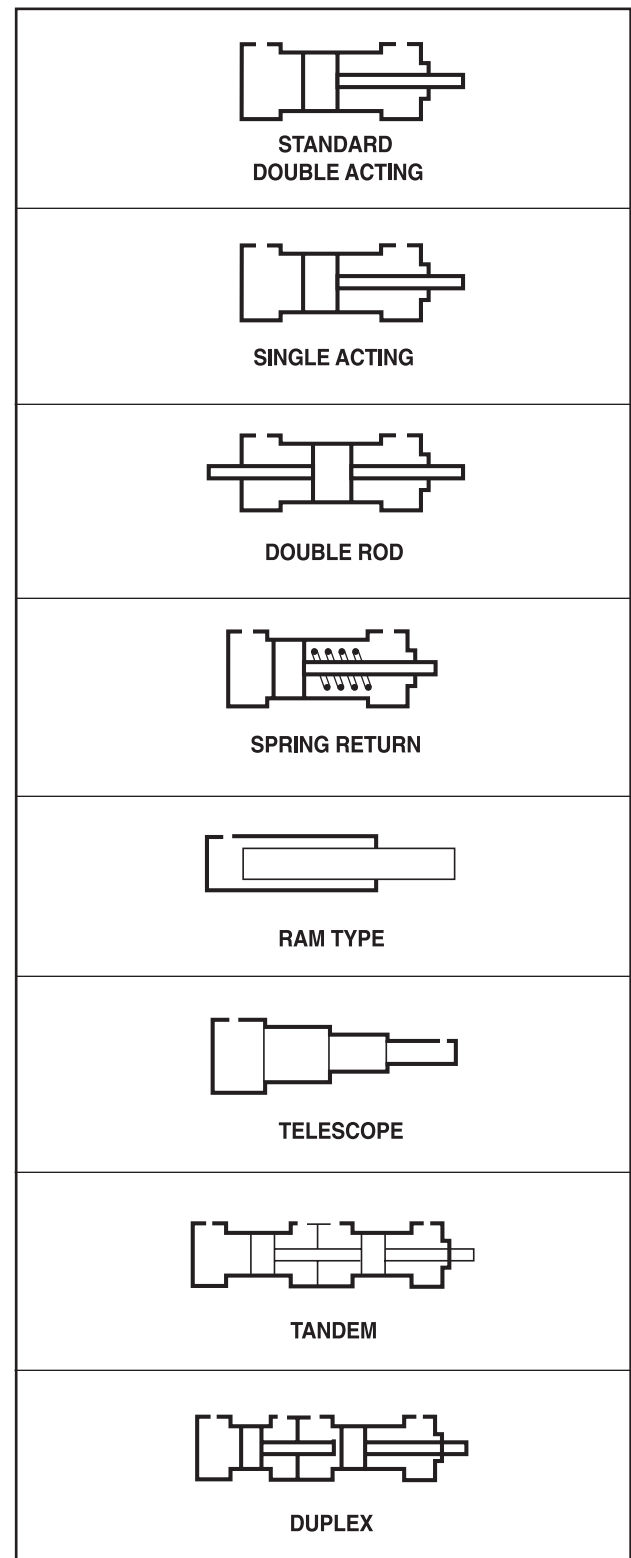
**Tandem Cylinders**

A tandem cylinder is made up of two cylinders mounted in line with pistons connected by a common piston rod and rod seals installed between the cylinders to permit double acting operation of each. Tandem cylinders allow increased output force when mounting width or height are restricted.

**Duplex Cylinders**

A duplex cylinder is made up of two cylinders mounted in line with pistons not connected and with rod seals installed between the cylinders to permit double acting operation of each. Cylinders may be mounted with piston rod to piston (as shown) or back to back and are generally used to provide three position operation.

Illustration B29



**A**

Product Index,  
Engineering Data

Product  
Index

Engineering  
Data



For inventory, lead time, and kit lookup, visit [www.pdnplu.com](http://www.pdnplu.com)

**A**

Product Index,  
Engineering Data

Product Index

Engineering Data

**Calculation of Cylinder Forces – Inch Based Product**

**Theoretical Push and Pull Forces for Pneumatic Cylinders**

**Push Force and Displacement**

Cylinder Bore Size (inch)	Piston Area (in <sup>2</sup> )	Cylinder Push Stroke Force in Pounds at Various Pressures (PSI)						Cu. Ft. Free Air at 80 lbs. Pressure, Required to Move Max. Load 1 Inch	Displacement Per Inch of Stroke (ft <sup>3</sup> )
		25	50	65	80	100	250		
1-1/8	0.994	25	50	65	80	99	249	0.00371	0.0005751
1-1/2	1.767	44	88	115	142	177	443	0.00659	0.0010225
2	3.14	79	157	204	251	314	785	0.01171	0.0018171
2-1/2	4.91	123	245	319	393	491	1228	0.01830	0.0028414
3-1/4	8.30	208	415	540	664	830	2075	0.03093	0.0048032
4	12.57	314	628	817	1006	1257	3143	0.04685	0.0072743
5	19.64	491	982	1277	1571	1964	4910	0.07320	0.0113657
6	28.27	707	1414	1838	2262	2827	7068	0.10541	0.0163599
7	38.49	962	1924	2502	3079	3849	9623	0.14347	0.0222743
8	50.27	1257	2513	3268	4022	5027	12568	0.18740	0.0290914

**Deductions for Pull Force and Displacement**

Piston Rod Dia. (inch)	Piston Rod Area (in <sup>2</sup> )	Piston Rod Diameter Force In Pounds At Various Pressures (PSI)						Cu. Ft. Free Air at 80 lbs. Pressure, Required to Move Max. Load 1 Inch	Displacement Per Inch of Stroke (ft <sup>3</sup> )
		25	50	65	80	100	250		
3/8	0.110	3	6	7	9	11	28	0.00041	0.0000636
1/2	0.196	5	10	13	16	20	49	0.00073	0.0001134
5/8	0.307	8	15	20	25	31	77	0.00114	0.0001776
1	0.785	20	39	51	65	79	196	0.00293	0.0004542
1-3/8	1.49	37	75	97	119	149	373	0.00554	0.0008622
1-3/4	2.41	60	121	157	193	241	603	0.00897	0.0013946

To determine Cylinder Pull Force or Displacement, deduct the following Force or Displacement corresponding to Rod Size, from selected Push Stroke Force or Displacement corresponding to Bore Size in table above.

**General Formula**

The cylinder output forces are derived from the formula:

- F = P × A
- Where F = Force in pounds.
- P = Pressure at the cylinder in pounds per square inch, gauge.
- A = Effective area of cylinder piston in square inches.

Free Air refers to normal atmospheric conditions of the air at sea level (14.7 PSI). Use above cu. ft. free air required data to compute CFM required from a compressor at 80 PSI. Cu. ft. of free air required at other pressures can be calculated using formula below.

$$V_1 = \frac{(P_2 + 14.7) V_2}{14.7}$$

- Where V<sub>1</sub> = Free air consumption per inch of stroke (cubic feet).
- V<sub>2</sub> = Cubic feet displaced per inch of stroke.
- P<sub>2</sub> = Gauge pressure required to move maximum load.



For inventory, lead times, and kit lookup, visit [www.pdnplu.com](http://www.pdnplu.com)



**Mounting Information**

Single rod type, fluid power cylinders are commonly available in 20 standard mounting styles ranging from head or cap end mounts to intermediate mounts. Many mounting styles are also available in double rod type cylinders. Refer to NFPA Std. B93.15-1981 or Parker air or hydraulic cylinder catalogs for detailed description.

Standard mounting styles for fluid power cylinders fall into three basic groups. The groups can be described as follows.

**Group 1** – Straight line force transfer with fixed mounts which absorb force on cylinder centerline.

**Group 3** – Straight line force transfer with fixed mounts which do not absorb force on cylinder centerline.

**Group 2** – Pivot force transfer with pivot mounts which absorb force on cylinder centerline and permit cylinder to change alignment in one plane.

Cylinder mounting directly affects the maximum pressure at which the fluid power cylinder can be used, and proper selection of mounting style will have a bearing on cylinder operation and service life. Whether the cylinder is used in thrust or tension, its stroke length, piston rod diameter and the method of connection to load also must be considered when selecting a mounting style.

Many pneumatic cylinders are offered for use with air pressure up to 250 PSI. The industrial tie rod types, known as NFPA cylinders, with square heads and caps, plus mountings lend themselves to standardized mounts which are similar in appearance for air cylinders.

**Straight Line Force Transfer (Group 1)**

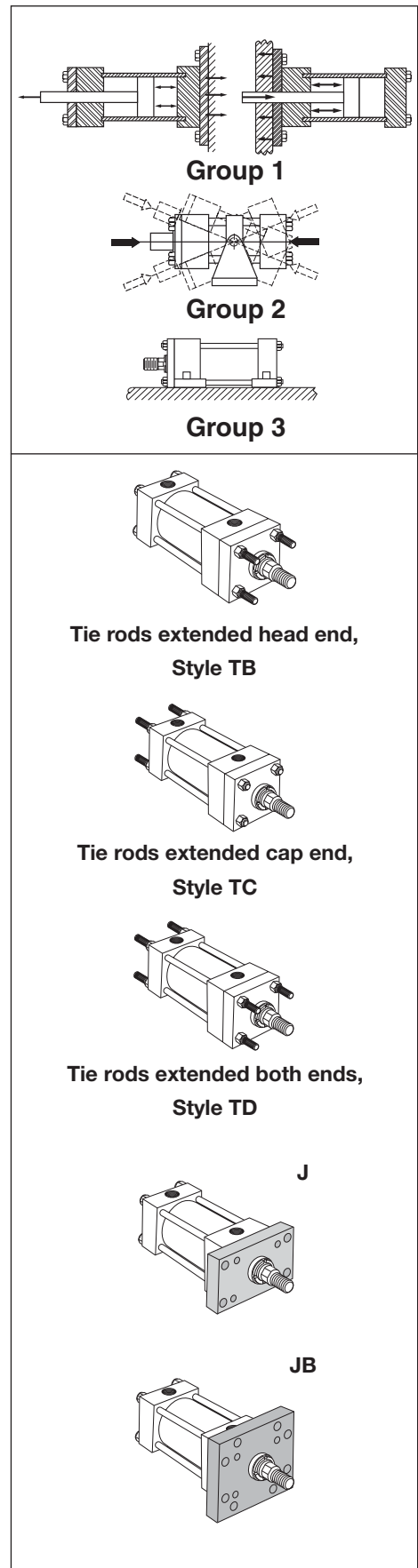
Cylinders with fixed mounts (Group 1) which absorb the force on centerline are considered the best for straight line force transfer. Tie rods extended, flange or centerline lug mounts are symmetrical and allow the thrust or tension forces of the piston rod to be distributed uniformly about the cylinder centerline. Mounting bolts are subjected to simple tension or simple shear without compound forces, and when properly installed damaging cylinder bearing sideloading is kept to a minimum.

**Tie Rods Extended** are considered to be of the centerline mount type. The cylinder tie rods are designed to withstand maximum rated internal pressure and can be extended and used to mount the cylinder at cap or head end. This often overlooked mounting will securely support the cylinder when bolted to the panel or machine member to which the cylinder is mounted. The torque value for the mounting nuts should be the same as the tie rod nut torque recommended by the cylinder manufacturer. Cylinders are available with tie rod extended both ends. In such applications one end is used for mounting and the opposite end to support the cylinder or to attach other machine components.

Tie rod mount cylinders may be used to provide thrust or tension forces at full rated pressures.

Tie rods extended head end (Style TB), cap end (Style TC) or extended both ends (Style TD) are readily available and fully dimensioned in Parker cylinder product catalogs.

**Flange Mount** cylinders are also considered to be centerline mount type and thus are among the best mounts for use on straight line force transfer applications. The machine designer has a choice of mounting styles at each end, such as head rectangular flange (Style J), head square flange (Style JB), cap rectangular flange (Style H), and cap square flange (Style HB). Selection of a flange mounting style depends, in part, upon whether the major force applied to the load will result in compression (push) or tension (pull) stresses of the cylinder piston rod. Cap end mounting styles are recommended for thrust loads (push), while head end mounting styles are recommended where the major load puts the piston rod in tension (pull).

**A**Product Index,  
Engineering DataProduct  
IndexEngineering  
Data

For inventory, lead time, and kit  
lookup, visit [www.pdnplu.com](http://www.pdnplu.com)

A7

**A**

**Product Index,  
 Engineering Data**

**Product  
 Index**

**Engineering  
 Data**

Flange mounts are best used when end face is mounted against the machine support member. (Fig. 1) This is especially true where head rectangular flange type (Style J) is used with major load in tension. In this mode, the flange is not subjected to flexure or bending stresses, nor are the mounting bolts stressed to unusually high levels. The use of head rectangular flange (Style J) mount with major load in compression (see Fig. 2) is not recommended except on reduced pressure systems. The use of Style J mount in compression subjects the flange to bending and the mounting bolts to tension stresses, which could result in early fatigue failure. For applications where push forces require full rated system pressure, head square flange (Style JB) mounts are recommended.

Cap flange mounts are also best used when end face is mounted against the machine support member. The use of cap rectangular flange mount, Style H, is not recommended on applications where the major load is in tension (pull) except at reduced pressure.

For applications where pull forces involved require full rated system pressure, cap square flange, Style HB mounts are recommended.

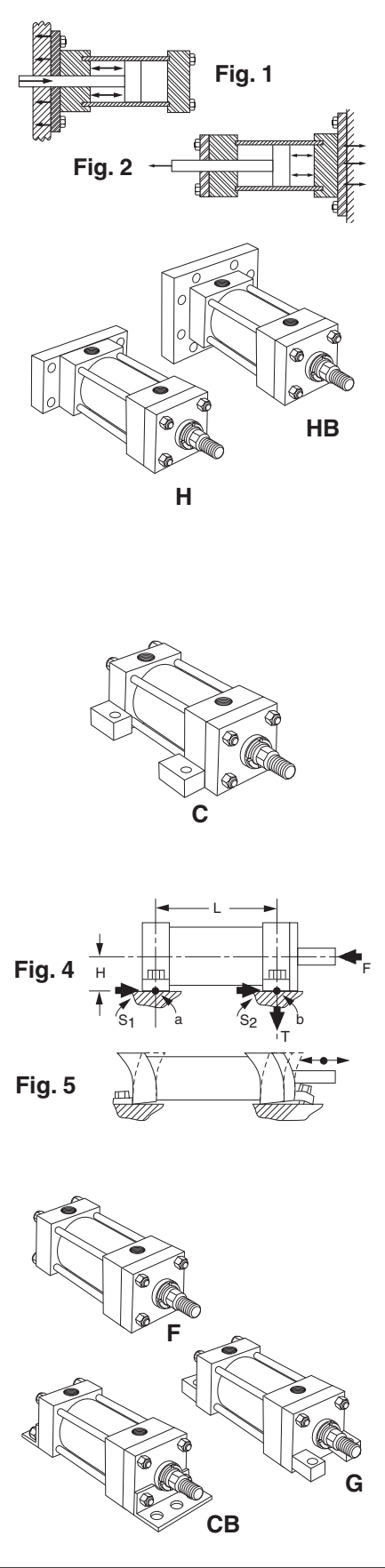
**Straight Line Force Transfer (Group 3)**

**Side Mount** cylinders are considered to be fixed mounts which do not absorb force on their centerline. Cylinders of this group have mounting lugs connected to the ends, and one style has side tapped holes for flush mounting. The plane of their mounting surfaces is not through the centerline of the cylinder, and for this reason side mounted cylinders produce a turning moment as the cylinder applies force to the load. (Fig. 4) This turning moment tends to rotate the cylinder about its mounting bolts. If the cylinder is not well secured to the machine member on which it is mounted or the load is not well-guided, this turning moment results in side load applied to rod gland and piston bearings. To avoid this problem, side mount cylinders should be specified with a stroke length at least equal to the bore size.

Shorter stroke, large bore cylinders tend to sway on their mountings when subjected to heavy loads, especially side end lug or side and angle mounts. (Fig. 5)

Side mount cylinders are available in several mounting styles, such as side lug (Style C), Side tapped (Style F or TEF), side end lug (Style G) and side end angle (Style CB). Of these, the side lug mount its the most popular and reliable, since the mounting lugs are part of the head and cap (4MA and 2A).

Side tapped mount is the choice when cylinders must be mounted side by side at minimum center-to-center distance. Another narrow side mount style is the side end lug mount which has lugs threaded to the tie rods. Thus the end lugs serve a dual function of holding the cylinder together and act as a means of mounting. This mounting style should be used only on medium- to light-duty applications, because the end lugs are subjected to compound stresses which could result in early failure.



For inventory, lead times, and kit lookup, visit [www.pdnplu.com](http://www.pdnplu.com)

The side end angle mount is also a narrow mount type, but is the weakest of the side mount styles. Its use should be limited to a maximum pressure of 150 PSI and minimum stroke length of two times the bore size. For pressure rating of longer strokes, consult the cylinder manufacturer.

Consideration should also be given to design of the machine frame used to support cylinders non-centerline mount, since stronger members are often required to resist bending moments. (See Fig. 6)

Side mount cylinders depend wholly on the friction of their mounting surfaces in contact with the machine member to absorb the force produced. Thus the torque applied to the mounting bolts is an important consideration. Since the mounting bolts are the same diameter as the tie rods for a given cylinder, it is recommended that the torque applied to the mounting bolts be the same as the tie rod torque recommended by the cylinder manufacturer for the given bore size.

For heavy loads or high shock conditions, side mounted cylinders should be held in place to prevent shifting by keying or pinning. A shear key, consisting of a plate extending from side of cylinder, can be supplied on most cylinders. (Fig. 7) This method may be used where a keyway can be milled into a machine member. It serves to take up shear loads and also provides accurate alignment of the cylinder.

Side lug mounts are designed so as to allow dowel pins to be used to pin the cylinder to the machine member. Pins, when used, are installed on both sides of the cylinder but not at both ends. (See Fig. 8)

The use of a separate shear key is fairly common. It should be placed at the proper end of the cylinder to absorb the major load. (see Fig. 9)

Side mount cylinders should not be pinned or keyed at both ends. Changes in temperature and pressure under normal operating conditions cause the cylinder to increase (or decrease) in length from its installed length and therefore must be free to expand and contract. If pinned or keyed at both ends, the advantages of cylinder elasticity in absorbing high shock loads will be lost. (Fig. 10)

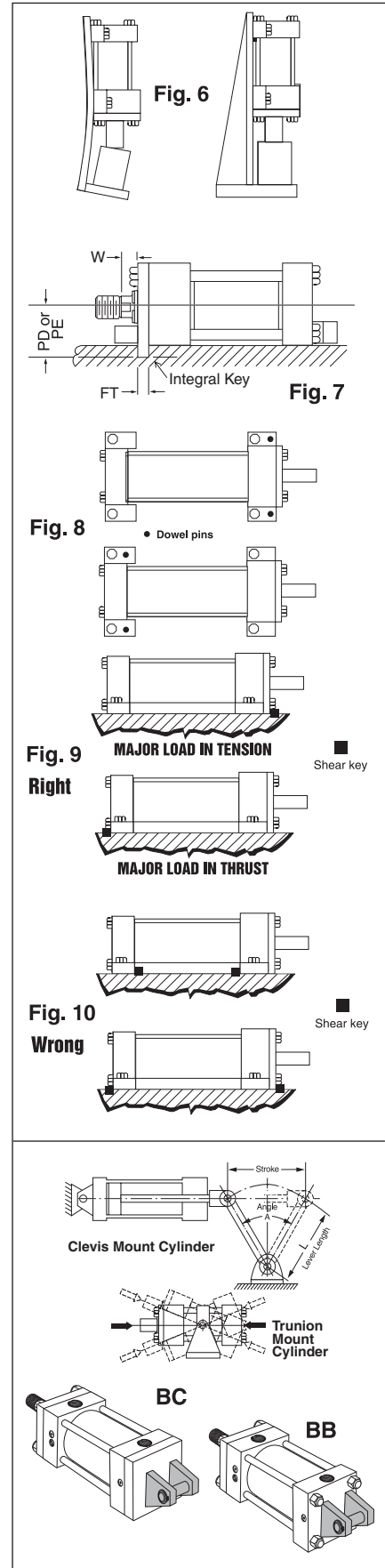
If high shock loads are the major consideration, the cylinder should be mounted and pins or shear key so located as to take full advantage of the cylinder's inherent elasticity. For major shock load in tension, locate key at rear face of head or pin the head in place. For major shock load in thrust, pin cap in place or locate key at front face of cap.

**Pivot Force Transfer (Group 2)**

Cylinders with pivot mounts which absorb force on centerline should be used on applications where the machine member to be moved travels in a curved path. There are two basic ways to mount a cylinder so that it will pivot during the work cycle: clevis or trunnion mounts, with variations of each. Pivot mount cylinders are available in cap fixed clevis (Style BB), cap detachable clevis (Style BC), cap spherical bearing (Style SB), head trunnion (Style D), cap trunnion (Style DB), and intermediate fixed trunnion (Style DD).

Pivot mount cylinders can be used on tension (pull) or thrust (push) applications at full rated pressure, except long stroke thrust cylinders are limited by piston rod column strength. See Piston Rod Selection Chart on page A14.

Clevis or single ear mounts are usually an integral part of the cylinder cap (though one style is detachable) and provide a single pivot point for mounting the cylinder. A pivot pin of proper length and of sufficient diameter to withstand the maximum shear load developed by the cylinder at rated operating pressure is included as a part of the clevis mount style. The fixed clevis mount, Style BB, is the most popular of the pivot force transfer types and is used on applications where the piston rod end travels in a curved path in one plane. It can be used vertically or horizontally or any angle in between. On long stroke push applications it may be necessary to use a larger diameter piston rod to prevent buckling or stop tube to minimize side loading due to "jackknife" action of cylinder in extended position. Fixed clevis mount cylinders will not function well if the curved path of piston rod travel is other than one plane. Such an application results in misalignment and causes the gland and piston bearing surfaces to be subjected to unnecessary side loading. For applications where the piston rod will travel in a path not more than 3° either side of the true plane motion, a cap spherical bearing mount is recommended. A spherical bearing rod eye should be used at rod end. Most spherical bearing mounts have limited pressure ratings. Consult cylinder manufacturer's product catalog.



**A**

Product Index,  
Engineering Data

Product  
Index

Engineering  
Data



For inventory, lead time, and kit lookup, visit [www.pdnplu.com](http://www.pdnplu.com)

**A**  
**Product Index, Engineering Data**  
**Product Index**  
**Engineering Data**

Cap detachable clevis mounts are usually used for air service. Cap detachable clevis mounts are longer, centerline of pivot pin to shoulder of piston rod, than fixed clevis mount in any given bore size. They are most often specified to avoid port relocation charges. Application parameters are the same as described for fixed clevis mounting.

Trunnion mount cylinders are a second type of pivot mounts used on applications where the piston rod travels in a curved path in one plane. Three styles are available – head trunnion (Style D), cap trunnion (Style DB) and intermediate fixed trunnion (Style DD). Trunnion pins are designed for shear loads only and should not be subjected to bending stresses. Pillow blocks, rigidly mounted with bearings at least as long as the trunnion pins, should be used to minimize bending stresses. The support bearings should be mounted as close to the head, cap or intermediate trunnion shoulder faces as possible.

Cap end trunnion mounts are used on cylinder applications similar to fixed clevis mounts, and the same application data applies.

Head trunnion mount cylinders can usually be specified with smaller diameter piston rods than cylinders with pivot point at cap end or at an intermediate position. This is evident in data shown in piston rod selection chart on page A14. On head end trunnion mount, long stroke, cylinder applications consideration should be given to the overhanging weight at cap end of cylinder. To keep trunnion bearing loading within limits, stroke lengths should be not more than 5 times the bore size. If cylinder stroke is greater than 5 times the bore size and piston speed exceeds 35 ft/minute, consult factory.

Intermediate fixed trunnion mount is the best of the trunnion mount types. The trunnion can be located so as to balance the weight of the cylinder, or it can be located at any point between the head or cap to suit the application. It is of fixed design, and the location of the trunnion must be specified (X1 dimension) at time of order. The location cannot be easily changed once manufactured.

Thrust exerted by a pivot transfer cylinder working at an angle is proportional to the angle of the lever arm which it operates. In Fig. 12 that vector force, T, which is at right angle to the lever axis, is effective for turning the lever. The value of T varies with the acute angle A between cylinder centerline and lever axes. To calculate effective thrust T, multiply cylinder thrust by the power factor shown in table below.

**Accessories**

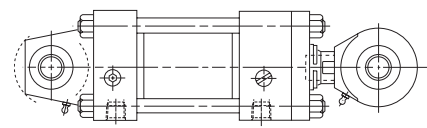
Rod clevises or rod knuckles are available for use with either fixed or pivot mount cylinders. Such accessories are usually specified with pivot mount cylinders and are used with pivot pin centerline in same axis as pivot pin centerline on cylinder. Pivot pins for accessories must be ordered separately.

Pin size of rod clevis or rod knuckle should be at least equal in diameter to the pin diameter of the cap fixed clevis pin for the cylinder bore size specified. Larger accessories are more costly and usually result in a mismatch of pin diameters, especially when used with oversize piston rods.

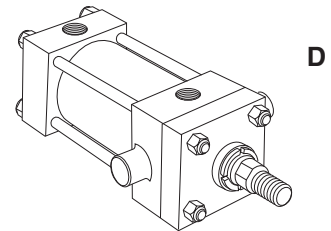
**Removable Trunnion Pins**

Removable trunnion pins are a convenience when machine structures or confined space prohibit the use of separate pillow blocks situated close to the cylinder sides.

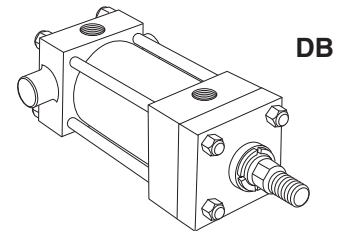
**Spherical Bearing Mount**



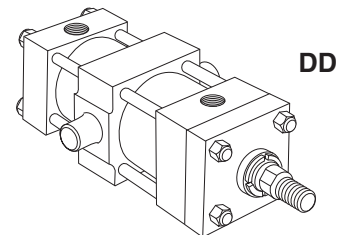
**Fig. 11**



**D**

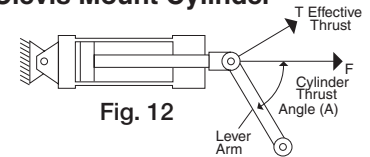


**DB**



**DD**

**Clevis Mount Cylinder**



**Fig. 12**

**Power Factor Table**

Angle A Degrees	Pwr. Factor (SIN A)	Angle A Degrees	Pwr. Factor (SIN A)
5	0.087	50	0.766
10	0.174	55	0.819
15	0.259	60	0.867
20	0.342	65	0.906
25	0.423	70	0.940
30	0.500	75	0.966
35	0.573	80	0.985
40	0.643	85	0.996
45	0.707	90	1.000



For inventory, lead times, and kit lookup, visit [www.pdnplu.com](http://www.pdnplu.com)

## Ports

### Ports

Parker hydraulic and pneumatic cylinders can be supplied with S.A.E. straight O-ring ports or N.P.T.F. pipe thread ports. For the type of port recommended and port size, see respective product catalogs. If specified on your order, extra ports can be provided on the sides of heads or caps that are not occupied by mountings or cushion valve on all cylinders.

Standard port location is position 1 as shown on line drawings in product catalog and Figure 1 below. Cushion adjustment needle valves are at positions 2 and 4 (or 3), depending on mounting style. Heads or caps which do not have an integral mounting can be rotated and assembled with ports at 90° or 180° from standard position. Mounting styles on which head or cap can be rotated at no extra charge are shown in Table A below. To order, specify by position number. In such assemblies the cushion adjustment needle valves rotate accordingly, since their relationship with port position does not change.

Figure 1

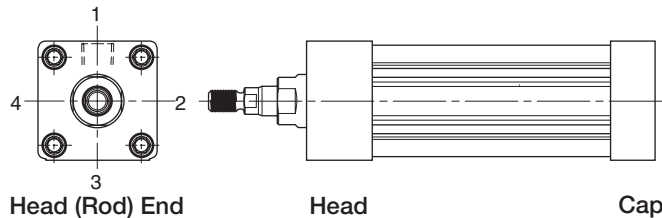


Table A

Mounting Style	Head End	Cap End
T, TB, TC, TD, H, HB, J, JB, DD	1, 2, 3 or 4	1, 2, 3 or 4
BB, DB	1, 2, 3 or 4	1 or 3
D	1 or 3	1, 2, 3 or 4
C, F	1	1

### Straight Thread Ports

The S.A.E. straight thread O-ring port is recommended for hydraulic applications. Parker will furnish this port configuration at positions shown in Table A above. This port can also be provided at positions other than those shown in Table A at an extra charge. Size number, tube O.D. and port thread size for S.A.E. ports are listed in Table C. S.A.E. ports are available at extra cost.

Table C

#### S.A.E. Straight Thread "O" Ring Ports

Size no.	Tube O.D. (in.)	Thread size	Size no.	Tube O.D. (in.)	Thread size
2	1/8"	5/16 - 24	12	3/4"	1-1/16 - 12
3	3/16"	3/8 - 24	—	—	—
4	1/4"	7/16 - 20	16	1"	1-5/16 - 12
5	5/16"	1/2 - 20	20	1-1/4"	1-5/8 - 12
6	3/8"	9/16 - 18	24	1-1/2"	1-7/8 - 12
8	1/2"	3/4 - 16	32	2"	2-1/2 - 12
10	5/8"	7/8 - 14	—	—	—

**Note:** For the pressure ratings of individual connectors, contact your connector supplier.

## Pneumatic Actuator Products Application Engineering Data

### Cylinder Port Options

- Option "T" SAE Straight Thread O-Ring Port. Recommended for most hydraulic applications.
- Option "U" Conventional NPTF Ports (Dry-Seal Pipe Threads). Recommended for pneumatic applications only.
- Option "R" BSPP Port (British Parallel Thread). ISO 228 port commonly used in Europe.
- Option "P" SAE Flange Ports Code 61. Recommended for hydraulic applications requiring larger port sizes.
- Option "B" BSPT (British Tapered Thread).
- Option "G" Metric Straight Thread Port similar to Option "R" with metric thread. Popular in some European applications.
- Option "Y" ISO-6149-1 Metric Straight Thread Port. Recommended for all hydraulic applications designed per ISO standards.

Ports can be supplied at positions other than those shown in Table A at an extra charge. To order, specify port position as shown in Figure 1.

### International Ports

Other port configurations to meet international requirements are available at extra cost. Parker cylinders can be supplied, on request, with British standard taper port (BSPT). Such port has a taper of 1 in 16 measured on the diameter (1/16" per inch). The thread form is Whitworth System, and size and number of threads per inch are as follows:

Table D

#### British Standard Pipe Threads

Nominal pipe size	No threads per inch	Pipe O.D.
1/8	28	0.383
1/4	19	0.518
3/8	19	0.656
1/2	14	0.825
3/4	14	1.041
1	11	1.309
1-1/4	11	1.650
1-1/2	11	1.882
2	11	2.347

British standard parallel internal threads are designated as BSP and have the same thread form and number of threads per inch as the BSPT type and can be supplied, on request, at extra cost. Unless otherwise specified, the BSP or BSPT port size supplied will be the same nominal pipe size as the N.P.T.F. port for a given bore size cylinder.

Metric ports options G or Y can also be supplied to order at extra cost.

A

Product Index,  
Engineering Data

Product  
Index

Engineering  
Data



For inventory, lead time, and kit lookup, visit [www.pdnplu.com](http://www.pdnplu.com)

**A**

**Product Index,  
Engineering Data**

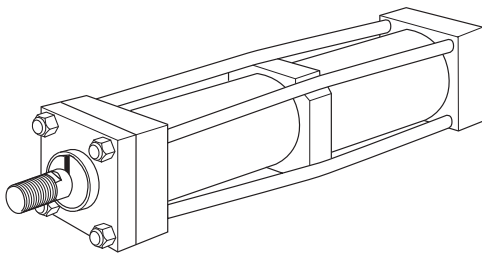
**Product  
Index**

**Engineering  
Data**

**Stroke Data**

Parker cylinders are available in any practical stroke length. The following information should prove helpful to you in selecting the proper stroke for your cylinder application.

**Stroke Tolerances** – Stroke length tolerances are required due to build-up of tolerances of piston, head, cap and cylinder body. Standard production stroke tolerances run +1/32" to -1/64" up to 20" stroke, +1/32" to -.020" for 21" to 60" stroke and +1/32" to -1/32" for greater than 60" stroke. For closer tolerances on stroke length, it is necessary to specify the required tolerance plus the operating pressure and temperature at which the cylinder will operate. Stroke tolerances smaller than .015" are not generally practical due to elasticity of cylinders. If machine design requires such close tolerances, use of a stroke adjuster (below) may achieve the desired result.



**Tie Rod Supports**

**Rigidity of Envelope** – The pre-stressed tie rod construction of Parker cylinders has advantages in rigidity within the limits of the cylinder tube to resist buckling. For long stroke cylinders within practical limits, Parker provides exclusive TIE ROD SUPPORTS (see table below) which move the tie rod centerlines radially outward.

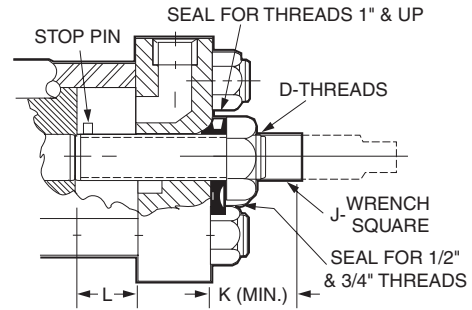
Standard tie rod supports are kept within the envelope dimensions of the head and cap, and generally do not interfere with mounting a long cylinder.

Number of Supports Required	Stroke (inches)													
	Bore	36	48	60	72	84	96	108	120	132	144	156	168	
1	—	1	1	1	2	Consult Factory								
1-1/2	—	—	1	1	1	2	2	2	3	3	3	3	4	
2	—	—	—	1	1	1	1	2	2	2	2	2	3	
2-1/2	—	—	—	—	—	1	1	1	1	1	1	2	2	
3-1/4	—	—	—	—	—	—	—	1	1	1	1	1	1	
4	—	—	—	—	—	—	—	—	—	—	1	1	1	

Note: 5" through 14" bore sizes — no supports required.

**Stroke Adjusters (only with metallic piston)**

**Stroke Adjusters** – For the requirement where adjusting the stroke is specified. Parker has several designs to offer, one of which is illustrated below. This is suitable for infrequent adjustment and is economical.\*



Here a "retracting stroke adjuster" must be called for in specifications, and the length of the adjustment must be specified.

Where frequent adjustment or cushions at the cap end are required, other designs are available according to application needs. Please contact Wadsworth, Ohio facility for more information.

\* Infrequent is defined by positioning the retract stroke in a couple of attempts at original machine set up. The frequent stroke adjuster is recommended for adjustments required after the original equipment has been adjusted by the original machine manufacturer.

Bore Size	D	J	K	L(Max.)
1-1/2, 2	1/2 - 20	5/16	15/16	5
2-1/2, 3-1/4, 4	3/4 - 16	7/16	1-1/4	8
5, 6	1 - 14	5/8	1-11/16	9
8	1-1/2 - 12	15/16	2-1/8	18



For inventory, lead times, and kit lookup, visit [www.pdnplu.com](http://www.pdnplu.com)

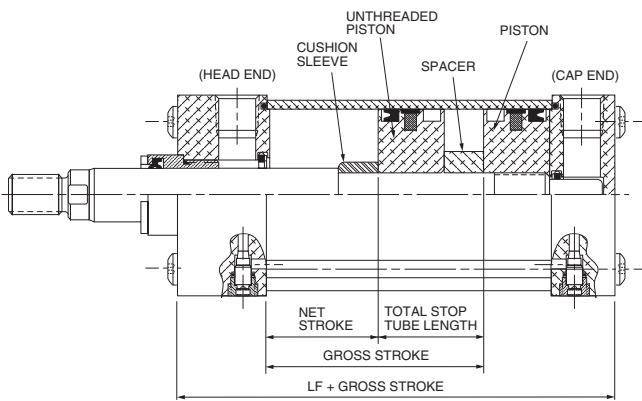
## Stop Tubing & Mounting Classes

### Stop Tubing (only with metallic piston)

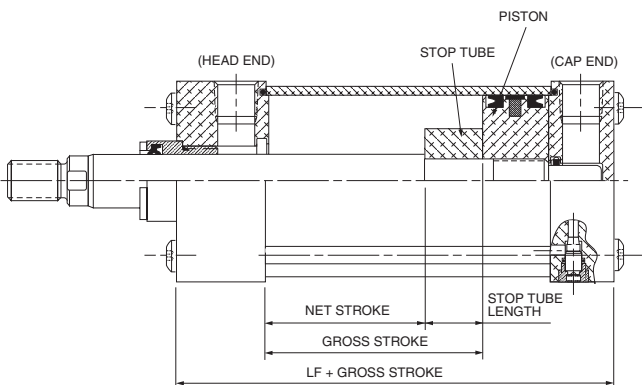
Long stroke cylinders, fixed or pivot mounted, tend to jackknife or buckle on push load applications, resulting in high bearing loading at the rod gland or piston. Use of a stop tube to lengthen the distance between the gland and piston when cylinder rod is fully extended is recommended to reduce these bearing loads. The drawing below shows stop tube construction for fluid power cylinders. Refer to chart on next page to determine stop tube length.

When specifying cylinders with long stroke and stop tube, be sure to call out the net stroke and the length of the stop tube. Machine design can be continued without delay by laying in a cylinder equivalent in length to the NET STROKE PLUS STOP TUBE LENGTH, which is referred to as GROSS STROKE.

Refer to the next page to determine stop tube length.



Double piston design is supplied on air cylinders with cushion head end or both ends.



This design is supplied on cushioned cap or non-cushioned cylinders.

### Cushion Selection

Cushions are required when cylinder piston rod speed exceeds 4" per second.

## Pneumatic Actuator Products Application Engineering Data

### Mounting Classes

Standard mountings for fluid power cylinders fall into three basic groups. The groups can be summarized as follows:

**Group 1** – Straight Line Force Transfer with fixed mounts which absorb force on cylinder centerline.

**Group 2** – Pivot Force Transfer. Pivot mountings permit a cylinder to change its alignment in one plane.

**Group 3** – Straight Line Force Transfer with fixed mounts which do not absorb force on cylinder centerline.

Because a cylinder's mounting directly affects the maximum pressure at which the cylinder can be used, the charts below should be helpful in the selection of the proper mounting combination for your application. Stroke length, piston rod connection to load, extra piston rod length over standard, etc. should be considered for thrust loads. Alloy steel mounting bolts are recommended for all mounting styles, and thrust keys are recommended for Group 3.

	<b>Group 1</b>
	FIXED MOUNTS which absorb force on cylinder centerline.
<b>HEAVY-DUTY SERVICE</b>	For Thrust Loads _____ For Tension Loads _____ Mtg. Styles TC Mtg. Styles TB
<b>MEDIUM-DUTY SERVICE</b>	For Thrust Loads _____ For Tension Loads _____ Mtg. Styles H, HB Mtg. Styles J, JB
<b>LIGHT-DUTY SERVICE</b>	For Thrust Loads _____ For Tension Loads _____ Mtg. Styles J, JB Mtg. Styles H, HB
	<b>Group 2</b>
	PIVOT MOUNTS which absorb force on cylinder centerline.
<b>HEAVY-DUTY SERVICE</b>	For Thrust Loads _____ For Tension Loads _____ Mtg. Styles DD, D Mtg. Styles BB, BC, DD, D, DB
<b>MEDIUM-DUTY SERVICE</b>	For Thrust Loads _____ For Tension Loads _____ Mtg. Styles BB, BC, BE Mtg. Styles BB, BC, BE
	<b>Group 3</b>
	FIXED MOUNTS which do not absorb force on the centerline.
<b>HEAVY-DUTY SERVICE</b>	For Thrust Loads _____ For Tension Loads _____ Mtg. Styles C Mtg. Styles C
<b>MEDIUM-DUTY SERVICE</b>	For Thrust Loads _____ For Tension Loads _____ Mtg. Styles F Mtg. Styles F
<b>LIGHT-DUTY SERVICE</b>	For Thrust Loads _____ For Tension Loads _____ Mtg. Styles CB† Mtg. Styles CB†
† Mounting style CB recommended for maximum pressure of 150 PSI.	

A

Product Index,  
Engineering Data

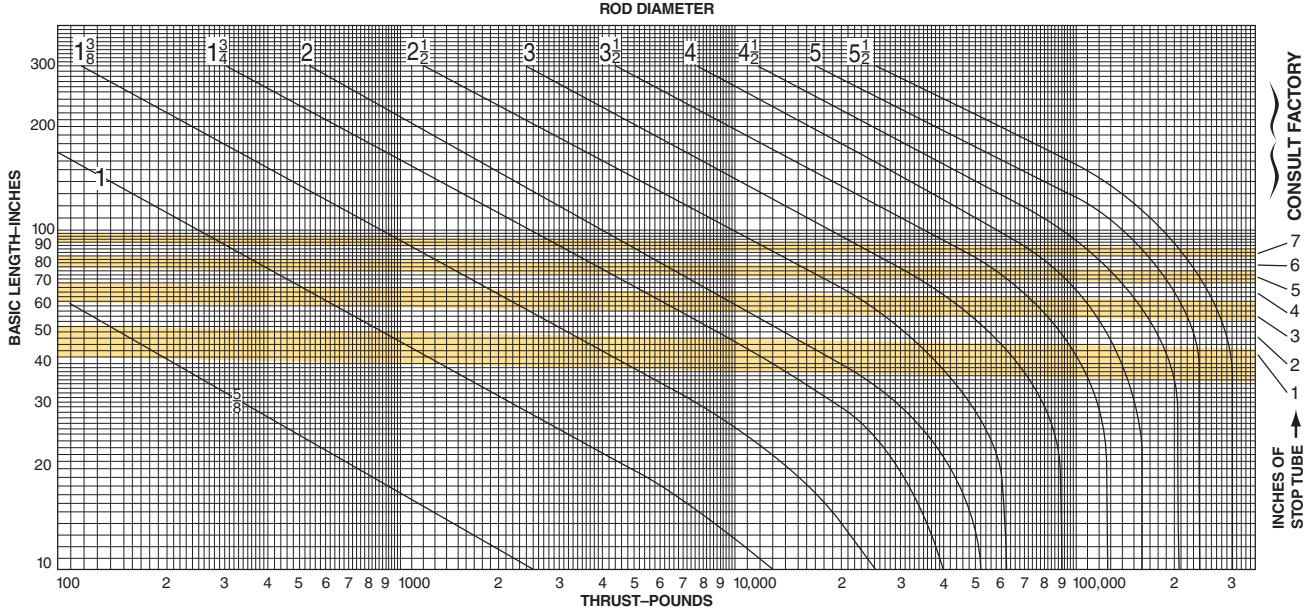
Product  
Index

Engineering  
Data



For inventory, lead time, and kit lookup, visit [www.pdnplu.com](http://www.pdnplu.com)

**Piston Rod – Stroke Selection Chart**



**How to Use the Chart**

The selection of a piston rod for thrust (push) conditions requires the following steps:

- Determine the type of cylinder mounting style and rod end connection to be used. Then consult the chart below and find the "stroke factor" that corresponds to the conditions used.
- Using this stroke factor, determine the "basic length" from the equation:

$$\text{Basic Length} = \frac{\text{Actual Stroke}}{\text{Stroke Factor}}$$

The graph is prepared for standard rod extensions beyond the face of the gland retainers. For rod extensions greater than standard, add the increase to the stroke in arriving at the "basic length."

- Find the load imposed for the thrust application by multiplying the full bore area of the cylinder by the system pressure.
- Enter the graph along the values of "basic length" and "thrust" as found above and note the point of intersection:

- The correct piston rod size is read from the diagonally curved line labeled "Rod Diameter" next above the point of intersection.

- The required length of stop tube is read from the right of the graph by following the shaded band in which the point of intersection lies.
- If required length of stop tube is in the region labeled "consult factory," submit the following information for an individual analysis:
  - Cylinder mounting style.
  - Rod end connection and method of guiding load.
  - Bore, required stroke, length of rod extension (Dim. "LA or LAF") if greater than standard, and series of cylinder used.
  - Mounting position of cylinder. (Note: If at an angle or vertical, specify direction of piston rod.)
  - Operating pressure of cylinder if limited to less than standard pressure for cylinder selected.

**Warning**

Piston rods are not normally designed to absorb bending moments or loads which are perpendicular to the axis of piston rod motion. These additional loads can cause the piston rod end to fail. If these types of additional loads are expected to be imposed on the piston rods, their magnitude should be made known to our Engineering Department so they may be properly addressed. Additionally, cylinder users should always make sure that the piston rod is securely attached to the machine member.

**Recommended mounting styles for maximum stroke and thrust loads**

**Groups 1 or 3**

Long stroke cylinders for thrust loads should be mounted using a heavy-duty mounting style at one end, firmly fixed and aligned to take the principal force. Additional mounting should be specified at the opposite end, which should be used for alignment and support. An intermediate support may also be desirable for long stroke cylinders mounted horizontally. Machine mounting pads can be adjustable for support mountings to achieve proper alignment.

**Group 2**

Style D — Trunnion on Head

Style DD — Intermediate Trunnion

Style DB — Trunnion on Cap or

Style BB — Clevis on Cap

Rod end connection	Case	Stroke factor
Fixed and Rigidly Guided	<b>I</b>	0.50
Pivoted and Rigidly Guided	<b>II</b>	0.70
Supported but not Rigidly Guided	<b>III</b>	2.00
Pivoted and Rigidly Guided	<b>IV</b>	1.00
Pivoted and Rigidly Guided	<b>V</b>	1.50
Pivoted and Rigidly Guided	<b>VI</b>	2.00



For inventory, lead times, and kit lookup, visit [www.pdnplu.com](http://www.pdnplu.com)

**A**  
 Product Index, Engineering Data  
 Product Index  
 Engineering Data



## Deceleration Force and Air Requirements

Cushion ratings for **Air Cylinders Only** are described in **Table b-2** and **Graph b-1**. To determine whether a cylinder will adequately stop a load without damage to the cylinder, the weight of the load (including the weight of the piston and the piston rod from **Table b-1**) and the maximum speed of the piston rod must first be determined. Once these two factors are known, the **Kinetic Energy Graph** may be used. Enter the graph at its base for the value of weight determined, and project vertically to the required speed value. The point of intersection of these two lines will be the cushion rating number required for the application.

To determine the total load to be moved, the weight of the piston and rod must be included.

**Total Weight** = weight of the piston and non-stroke rod length (column 1) + weight of the rod per inch of stroke x the inches of stroke (Column 2) + the load to be moved.

**Example:** a 3-1/4" bore cylinder with a 1" rod diameter and 25" of stroke; external load to be moved is 85 lbs. Total load to be moved is then (3.3 lbs) + (0.223 lbs/inch X 25 inches) + (85 lbs) for a total of 93.9 lbs.

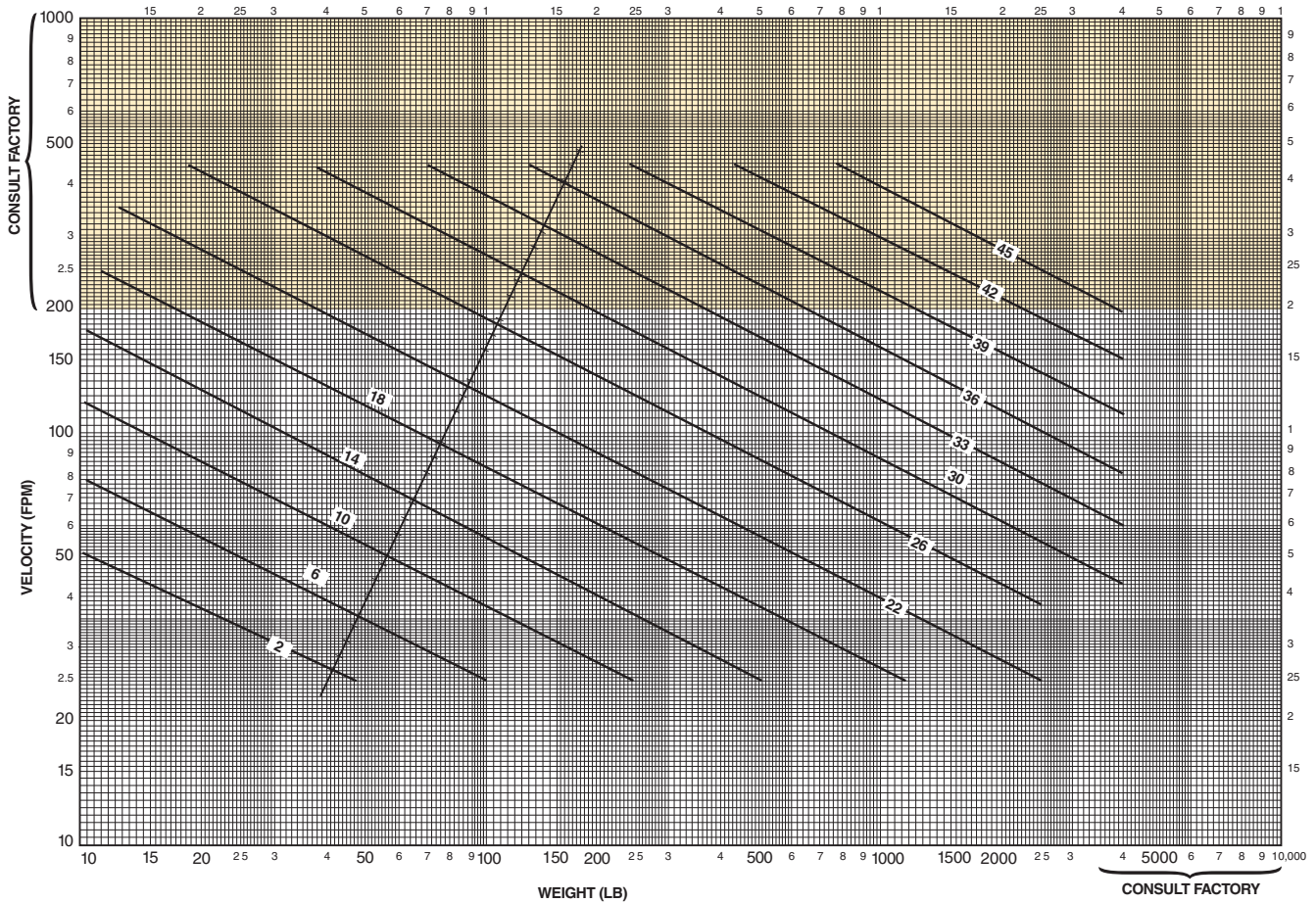
## Pneumatic Actuator Products Application Engineering Data

**Table b-1**  
**4MA Piston Rod Assembly Weight Table**

Bore	Rod dia. mm	Column 1 Basic weight for piston and non-stroke rod (lbs)	Column 2 Basic weight for each 1" of stroke (lbs)
1-1/2	5/8	1.1	0.087
	1	N/A	N/A
2	5/8	1.2	0.087
	1	2.1	0.223
2-1/2	5/8	1.5	0.087
	1	2.3	0.223
3-1/4	1	3.3	0.223
	1-3/8	4.9	0.421
4	1	3.8	0.223
	1-3/8	5.4	0.421
5	1	5.0	0.223
	1-3/8	6.5	0.421
6	1-3/8	8.3	0.421
	1-3/4	11.8	0.682
8	1-3/8	12.4	0.421
	1-3/4	15.0	0.682

Note: aluminum piston used for weight calculation

**Graph b-1**  
**Kinetic Energy Graph – Air Cylinders**



**A**

Product Index,  
Engineering Data

Product  
Index

Engineering  
Data



For inventory, lead time, and kit lookup, visit [www.pdnplu.com](http://www.pdnplu.com)

A15

**Parker Hannifin Corporation**  
Pneumatic Division  
Richland, Michigan  
[www.parker.com/pneumatics](http://www.parker.com/pneumatics)

## Cushion Ratings and Air Requirements

## Pneumatic Actuator Products Application Engineering Data

A

Product Index,  
Engineering Data

Product Index

Engineering Data

Now refer to **Table b-2** and find the cushion ratings, using bore size and rod diameter of the cylinder selected. If a simple circuit is used, with no meter out or speed control, use the "Rating with No Back Pressure" column values. If a meter out or speed control is to be used, use the "Rating with Back Pressure" column values. If the cushion rating found in **Table b-2** below is **greater** than the number determined in **Graph b-1**, then the cylinder will stop the load adequately. If the cushion rating in **Table b-2** is **smaller** than the number found in **Graph b-1**, then a larger bore cylinder should be used. In those applications where back pressures exist in the exhaust lines, it is possible to exceed the cushion ratings shown in **Table b-2**. In these cases, consult the factory and advise the amount of back pressure.

**Table b-2**  
**4MA Air Cylinder Cushion Ratings Table**

Bore	Rod dia. mm	Rating with no back pressure	Rating with back pressure
1-1/2	5/8	8	14
	1	N/A	N/A
2	5/8	12	18
	1	9	15
2-1/2	5/8	14	20
	1	14	19
3-1/4	1	18	24
	1-3/8	17	23
4	1	20	27
	1-3/8	20	26
5	1	23	28
	1-3/8	23	28
6	1-3/8	26	31
	1-3/4	26	31
8	1-3/8	29	35
	1-3/4	29	34

In general, if the cushion rating number from the Kinetic Energy Graph is greater than the cushion rating for a particular bore and rod diameter, other and external means of decelerating the load will be necessary for proper cylinder application. Parker options include shock absorbers, Par-Check hydraulic resistance units and NuCushion bumpers.

Shock absorbers provide the greatest selection of decelerating products, and many can be incorporated into the cap end of cylinders for retract stroke deceleration. Additional product information can be found in Industrial Shock Absorbers Catalog AU08-1022-1/NA, and please contact the Wadsworth, OH facility for cylinder modification details.



Shock Absorber



NuCushion Bumper  
2-1/2" - 4" Bores

### Inch Based Cylinders Air Requirement Per Inch of Cylinder Stroke

The amount of air required to operate a cylinder is determined from the volume of the cylinder and its cycle in strokes per minute. This may be determined by use of the following formulae which apply to a single-acting cylinder.

$$V = \frac{3.1416 L D^2}{4} \quad C = \frac{fV}{1728}$$

- Where:
- V = Cylinder volume, cu. in.
  - L = Cylinder stroke length, in.
  - D = Internal diameter of cylinder in.
  - C = Air required, cfm
  - f = Number of strokes per minute

The air requirements for a double-acting cylinder is almost double that of a single-acting cylinder, except for the volume of the piston rod.



For inventory, lead times, and kit lookup, visit [www.pdnplu.com](http://www.pdnplu.com)

The air flow requirements of a cylinder in terms of cfm should not be confused with compressor ratings which are given in terms of free air. If compressor capacity is involved in the consideration of cylinder air requirements it will be necessary to convert cfm values to free air values. This relationship varies for different gauge pressures.

Thrust (pounds) = operating pressure x area of cylinder bore.

**Note:** That on the "out" stroke the air pressure is working on the entire piston area but on the "in" stroke the air pressure works on the piston area less the rod area.

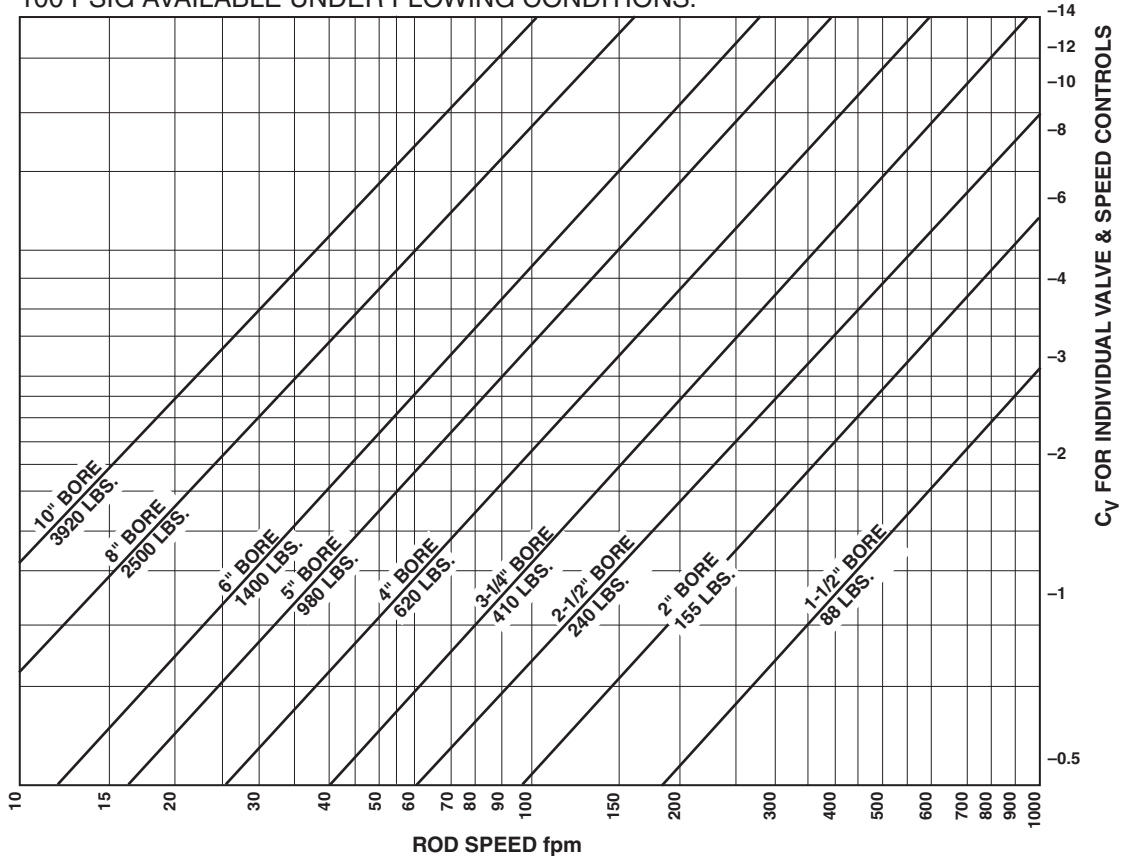
**Graph b-2** and **b-3** offer a simple means to select pneumatic components for dynamic cylinder applications. It is only necessary to know the force required, the desired speed and the pressure which can be maintained at the inlet to the air preparation system. The graphs assume average conditions relative to air line sizes, system layout, friction, etc. At higher speeds, consider appropriate cushioning of cylinders.

The general procedure to follow when using these graphs is:

1. Select the appropriate graph depending upon the pressure which can be maintained to the system – **Graph b-2** for 100 PSIG and **Graph b-3** for 80 PSIG.
2. Determine appropriate cylinder bore. Values underneath the diagonal cylinder bore lines indicate the maximum recommended dynamic thrust developed while the cylinder is in motion. The data in the table at the bottom of each graph indicates available static force applications in which clamping force is a prime consideration in determining cylinder bore. Please reference table number b-3 and b-4 for approximate thrust developed at a given operating pressure.

**Graph b-2**

THIS GRAPH IS DETERMINED BY HAVING 100 PSIG AVAILABLE UNDER FLOWING CONDITIONS.



**Table b-3**  
**Thrust Developed**

Bore Size	1-1/2"	2"	2-1/2"	3-1/4"	4"	5"	6"	8"
Dynamic Thrust (lbs.)	88	155	240	410	620	980	1400	2500
Static Thrust (lbs.)	177	314	491	830	1250	1960	2820	5020



For inventory, lead time, and kit lookup, visit [www.pdnplu.com](http://www.pdnplu.com)

3. Read upward on appropriate rod speed line to intersection with diagonal cylinder bore line. Read right from inter-section point to determine the required  $C_v$  of the valve and the speed controls. Both the valve and speed controls must have this  $C_v$ .

The following examples illustrate use of the graphs:

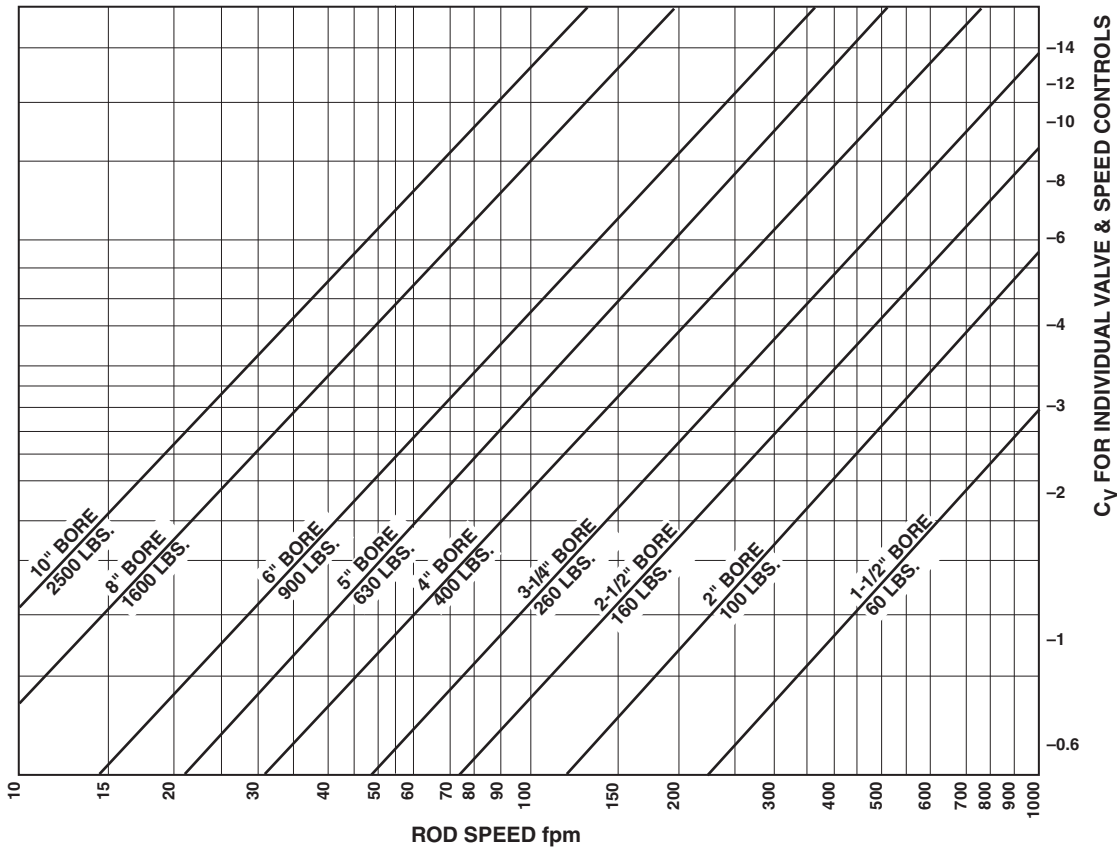
**Example 1:** Assume it is necessary to raise a 900-pound load 24 inches in two seconds. With 100 PSIG maintained at the inlet to the air preparation system, use **Graph b-2**. The 5-inch bore cylinder is capable of developing the required thrust while in motion. Since 24 inches in two seconds is equal to 60 fpm, read upward on the 60 fpm line to the intersection of the 5-inch bore diagonal line. Reading to the right indicates that the required valve and speed controls must each have a  $C_v$  of over 1.9.

**Example 2:** Assume similar conditions to Example 1 except that only 80- PSIG will be available under flowing conditions. Using **Graph b-3**, a 6-inch bore cylinder is indicated. Read upward on the 60 fpm line to the intersection point. Interpolation of the right-hand scale indicates a required valve and speed control  $C_v$  of over 2.8.

**Example 3:** Assume similar conditions to Example 1 except that the load is being moved in a horizontal plane with a coefficient of sliding friction of 0.2. Only a 180-pound thrust is now required (900 lb. x 0.2). Consult **Graph b-3**. The 2-1/2 inch bore cylinder will develop sufficient thrust, and at 60 fpm requires a valve and speed control  $C_v$  of about 0.5.

**Graph b-3**

THIS GRAPH IS DETERMINED BY HAVING 80 PSIG AVAILABLE UNDER FLOWING CONDITIONS.



**Table b-4**  
**Thrust Developed**

Bore Size	1-1/2"	2"	2-1/2"	3-1/4"	4"	5"	6"	8"
Dynamic Thrust (lbs.)	60	100	160	260	400	630	900	1600
Static Thrust (lbs.)	141	251	393	663	1000	1570	2260	4010



For inventory, lead times, and kit lookup, visit [www.pdnplu.com](http://www.pdnplu.com)

## Rod End Data

Rod end dimension symbols as shown comply with the National Fluid Power Association dimensional code. The following chart indicates the symbols used in this catalog.

Description	Symbol
Thread diameter and pitch	KK or CC
Length of thread	A
Length of rod extension from face of gland retainer to end of retracted rod	LA or LAF (Male Thread) W or WF (Female Thread)

Five rod ends for Parker cylinders are offered as shown on the dimension pages of this catalog. They are Parker styles 4, 6, 8, 9 and 55, and all five are optional without price penalty.

### Warning

Piston rods are not normally designed to absorb bending moments or loads which are perpendicular to the axis of piston rod motion. These additional loads can cause the piston rod end to fail. If these types of additional loads are expected to be imposed on the piston rods, their magnitude should be made known to our Application Engineering Department so they may be properly addressed. Additionally, cylinder users should always make sure that the piston rod is securely attached to the machine member.

On occasion cylinders are ordered with double rods. In some cases a stop is threaded onto one of the piston rods and used as an external stroke adjuster. This can cause a potential safety concern and can also lead to premature piston rod failure. The external stop will create a pinch point and the cylinder user should consider appropriate use of guards. If an external stop is not parallel to the final contact surface it will place a bending moment on the piston rod. An external stop will also negate the effect of a cushion and will subject the piston rod to an impact loading. These two (2) conditions can cause piston rod failure. The use of external stroke adjusters should be reviewed with our Application Engineering Department.

## Piston Rod End Threads

Standard piston rod end thread lengths are shown as dimension "A" in Catalog dimension pages. Special rod end threads which are two times standard length can be supplied at a small extra cost. Available thread lengths are shown in the table below. To order, add suffix "2" to piston rod model number code and specify as Style #42 or Style #82.

### Optional Piston Rod End Studs

Piston rod dia.	Rod end thread style #42		Rod end thread style #82	
	Thread dia. & pitch (KK)	Length (= 2 × A)	Thread dia. & pitch (CC)	Length (= 2 × A)
5/8	7/16-20	1-1/2	1/2-20	1-1/2
1	3/4-16	2-1/4	7/8-14	2-1/4
1-3/8	1-14	3-1/4	1-1/4 - 12	3-1/4
1-3/4	1-1/4 - 12	4	1-1/2 - 12	4

## International Rod End Threads

Piston rod threads to meet international requirements are available at extra cost. Parker cylinders can be supplied with British standard fine (W) or metric (M). To order, specify in model number. For dimensions, consult factory.

## Special Rod Ends

If a rod end configuration other than the standard styles is required, such special rod ends can be provided. The designation "Style 3" is assigned to such specials and is incorporated in the cylinder model number. To order, specify "Style 3" and give desired dimensions for KK; A; LA, LAF, W, or WF. If otherwise special, send a dimensioned sketch.

## Special Assemblies from Standard Parts

Each dimensioned drawing in this catalog has position numbers shown on the end view to identify the four sides of the cylinder. These aid in communications and simplify the writing of specifications that cover changes in port positions, etc. Following are several suggested special assemblies that can be made up from standard parts.

- By calling out the position numbers for the desired locations for head and cap ports, many mounting styles can be assembled with ports located at 90° or 180° from standard. In such special assemblies, the cushion needle valves are also repositioned since their relation with the port position does not change.
- On mounting styles D, DB and DD, the cushion needle valves are provided only on the side position 3 on the head or cap which accommodates the mounting. The opposite head or cap can be rotated.
- Standard mountings in different combinations can be provided: for example Style J mounting on head end with Style C on the cap end. This would be made up from standard parts and would be designated Model (bore size) **JC-4MAU14A** (stroke).

## Single-Acting Cylinders

Double-acting cylinders are supplied as standard. They can also be used as single-acting cylinders where air or hydraulic force is applied to only one side of the piston, with the load or other external forces acting to "return" the piston after pressure is exhausted.

## Spring-Returned, Single-Acting Cylinders (only with metallic piston)

Single-acting, spring-returned models can also be provided. Load conditions and friction factors must be considered in supplying the proper spring for the application. In addition, it is necessary that information be supplied as to which side of the piston the spring should act upon. Specify "Spring to return piston rod" or "Spring to advance piston rod."

On longer stroke spring-returned cylinders, it is recommended that tie rod extensions be specified on the cylinder end in which the spring is located so that the cap or head against which the spring is acting can be "backed-off" slowly until compression of the spring is relieved. In such cases it should also be specified that the tie rod nuts be welded to the tie rods at the opposite end of the cylinder to further insure safe disassembly.

Consult factory when ordering spring-returned cylinders.

**A**

**Product Index,  
Engineering Data**

**Product  
Index**

**Engineering  
Data**

**Modifications**

The following modifications can be supplied on most cylinders.

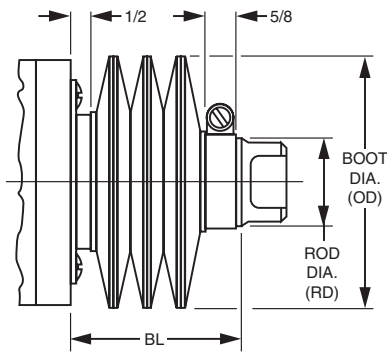
**Metallic Rod Wiper Gland Assembly**

When specified metallic rod wipers can be supplied instead of the standard wiper. Recommended in applications where contaminants tend to adhere to the extended piston rod and would damage the standard wiper. Installation of metallic rod wiper does not affect cylinder dimensions. It is available at extra cost. Please contact the Wadsworth, OH facility for more information.

**Rod End Boots**

Most Parker cylinders have a hardened bearing surface on the standard piston rod to resist external damage, and are equipped with a high efficiency wiper to remove external dust and dirt. Exposed piston rods that are subjected to contaminants with air hardening properties, such as paint, should be protected. In such applications, the use of a collapsing cover should be considered. This is commonly referred to as a "boot". Calculate the longer rod end required to accommodate the collapsed length of the boot from the following data.

<b>RD</b>	1/2	5/8	1	1-3/8	1-3/4
<b>OD</b>	2-1/4	2-1/4	2-5/8	3	3-3/8
<b>LF</b>	.13	.13	.13	.13	.13



To determine extra length of piston rod required to accommodate boot, calculate:

$$BL = \text{Stroke} \times LF + 1-1/8"$$

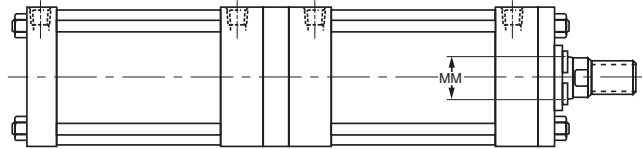
BL + std LAF (male rod end) or WF (female rod end) dimension = length of piston rod to extend beyond the head face.

**Note:** Please compare the Boot OD size to the standard E dimension per desired cylinder series and bore. This may be critical for foot mounted cylinders.

Rod Boots are available for many cylinder series. Please contact the Wadsworth, OH facility for rod boot options.

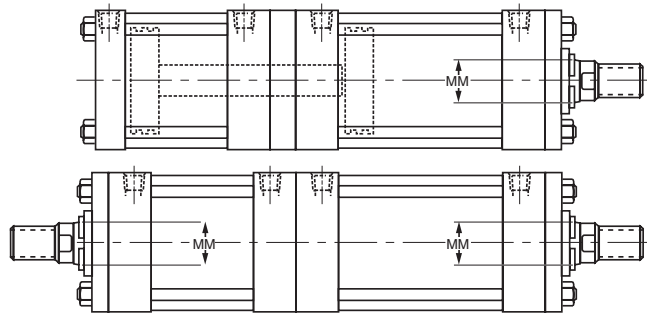
**Tandem Cylinders**

A tandem cylinder is made up of two cylinders mounted in line with pistons connected by a common piston rod and rod seals installed between the cylinders to permit double acting operation of each. Tandem cylinders allow increased output force when mounting width or height are restricted. Please contact the Wadsworth, OH facility for more information.



**Duplex Cylinders**

A duplex cylinder is made up of two cylinders mounted in line with pistons not connected and with rod seals installed between the cylinders to permit double acting operation of each. Cylinders may be mounted with piston rod to piston (as shown) or back to back and are generally used to provide three position operation. Please contact the Wadsworth, OH facility for more information.



For inventory, lead times, and kit lookup, visit [www.pdnplu.com](http://www.pdnplu.com)

### Design Torque

Design torque represents the maximum torque that an actuator must supply in an application. This maximum is the greater of the Demand Torque or the Cushion Torque. If the demand torque exceeds what the actuator can supply, the actuator will either move too slowly or stall. If the cushion torque is too high, the actuator may be damaged by excessive pressure. Demand torque and cushion torque are defined below in terms of load, friction, and acceleration torque.

Equations for calculating demand torque and cushion torque for some general applications are provided on the following pages.

### T - Torque

The amount of turning effort exerted by a rotary actuator.

### T<sub>D</sub> - Demand Torque

This is the torque required from the actuator to do the job and is the sum of the load torque, friction torque, and acceleration torque, multiplied by an appropriate design factor. Design factors vary with the applications and the designers' knowledge.

$$\text{Equation 4-3) } T_D = T_\alpha + T_f + T_L$$

### T<sub>L</sub> - Load torque

This is the torque required to equal the weight or force of the load. For example, in Fig. 4-8a, the load torque is 563 Nm (5000 lb-in); in Fig. 4-8b the load torque is zero; in Fig. 4-8c the load torque is 563 Nm (5000 lb-in). The load torque term is intended to encompass all torque components that aren't included in the friction or acceleration terms.

### T<sub>f</sub> - Friction torque

This is the torque required to overcome friction between any moving parts, especially bearing surfaces. In Fig. 4-8a, the friction torque is zero for the hanging load; in Fig. 4-8b the friction torque is 775 Nm (6880 lb-in) for the sliding load; in Fig. 4-8c the friction torque is zero for the clamp.

$$\text{Equation 4-4) } T_f = \mu Wr$$

### T<sub>a</sub> - Acceleration Torque

This is the torque required to overcome the inertia of the load in order to provide a required acceleration or deceleration. In Fig. 4-8a the load is suspended motionless so there is no acceleration. In Fig. 4-8b, the load is accelerated from 0 to some specified angular velocity. If the mass moment of inertia about the axis of rotation is I and the angular acceleration is a, the acceleration torque is equal to Ia. In Fig. 4-8c there is no acceleration.

Some values for mass moment of inertia are given in Table 4.

Some useful equations for determining a are listed in Table 5. Equation 5 below shows the general equation for acceleration torque.

$$\text{Equation 4-5) } T_\alpha = I\alpha$$

### T<sub>c</sub> - Cushion Torque

This is the torque that the actuator must apply to provide a required deceleration. This torque is generated by restricting the flow out of the actuator (meter-out) so as to create a back pressure which decelerates the load. This back pressure (deceleration) often must overcome both the inertia of the load and the driving pressure (system pressure) from the pump. See applications.

$$\text{Equation 4-6) } T_c = T_\alpha + \frac{P_r V}{\theta} - T_f \pm T_L$$

The friction torque T<sub>f</sub> reduces the torque the actuator must apply to stop the load. The load torque T<sub>L</sub> may add to, or subtract from the torque required from the actuator, depending upon the orientation of the load torque. For example, a weight being swung upward would result in a load torque that is subtracted.

**Warning: Rapid deceleration can cause high pressure intensification at the outlet of the actuator. Always insure that cushion pressure does not exceed the manufacturer's pressure rating for the actuator.**

### KE - Kinetic Energy (1/2 Jmω<sup>2</sup>)

This is the amount of energy that a rotating load has. The rotator must be able to stop the load. All products have kinetic energy rating tables. Choose the appropriate deceleration option (i.e., bumper, cushions, shock absorbers, etc.) that meets or exceeds the kinetic energy of the load.

A

Product Index,  
Engineering DataProduct  
IndexEngineering  
Data

**Pages A21-A22 and A24-A25 excerpted  
from the Parker Hannifin Design  
Engineers Handbook.**



For inventory, lead time, and kit  
lookup, visit [www.pdnplu.com](http://www.pdnplu.com)

A21

**Parker Hannifin Corporation**  
Pneumatic Division  
Richland, Michigan  
[www.parker.com/pneumatics](http://www.parker.com/pneumatics)

**Demand Torque Examples**

**A**

Product Index,  
Engineering Data

Product  
Index

Engineering  
Data

**A) Example of load torque**

The load is held motionless as shown.

$$T_D = T_\alpha + T_f + T_L$$

$$T_\alpha = 0$$

$$T_f = 0$$

$$T_L = (500 \text{ lb})(10 \text{ in}) = 5,000 \text{ lb-in}$$

$$T_D = 5,000 \text{ lb-in}$$

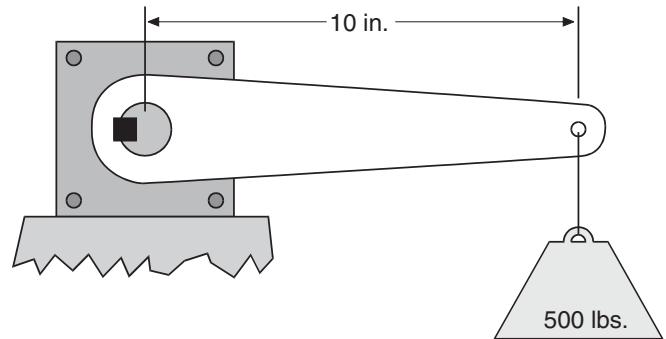


Figure 4-8a

**B) Due to friction and acceleration**

The 500 lb rotating index table is supported by bearings with a coefficient of friction of 0.25. The table's acceleration  $a$  is  $2 \text{ rad/sec}^2$ . The table's mass moment of inertia  $I$  is  $2,330 \text{ lb-in-sec}^2$ .

$$T_D = T_\alpha + T_f + T_L$$

$$T_\alpha = I\alpha = (2,330 \text{ lb-in-sec}^2)(2/\text{sec}^2) = 4,660 \text{ lb-in}$$

$$T_f = \mu W r_b = 0.25 (500 \text{ lb})(55 \text{ in}) = 6,880 \text{ lb-in}$$

$$T_L = 0$$

$$T_D = 4,660 \text{ lb-in} + 6,880 \text{ lb-in} = 11,540 \text{ lb-in}$$

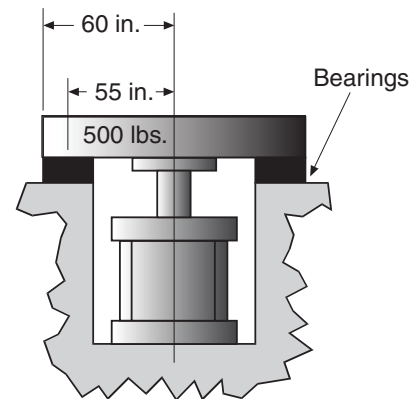


Figure 4-8b

**C) Load torque example**

$$T_D = T_\alpha + T_f + T_L$$

$$T_\alpha = 0$$

$$T_f = 0$$

$$T_L = (500 \text{ lb})(10 \text{ in}) = 5,000 \text{ lb-in}$$

$$T_D = 5,000 \text{ lb-in}$$

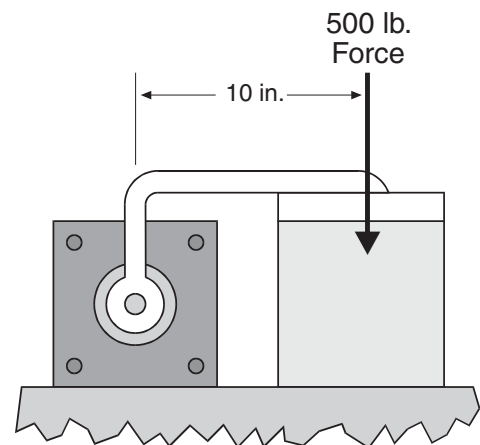


Figure 4-8c



For inventory, lead times, and kit lookup, visit [www.pdnplu.com](http://www.pdnplu.com)



**Torque Selection**

Parker rotary actuators provide output torque up to 10,000 lb-in. The chart to the right shows the nominal torque output range of various actuator models at 100 PSI.

**Caution:**

This chart is intended as a guide only. Refer to actual product data in this catalog before specifying an actuator. Factors such as pressure rating, rotation, and actual torque output may be affected by specific product details and options.

**Nominal Torque at 100 PSI**

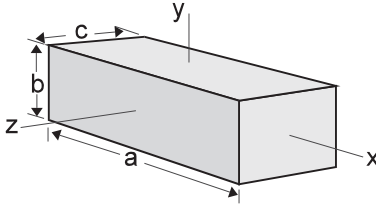
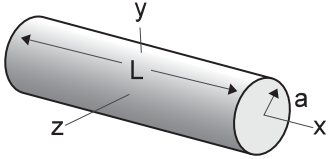
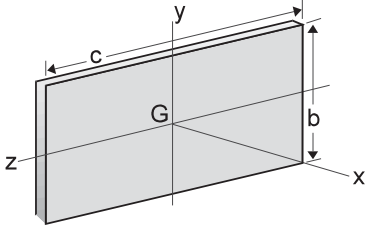
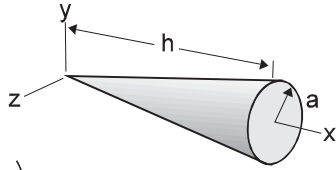
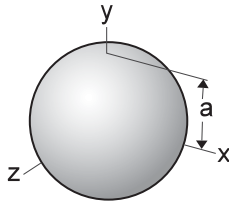
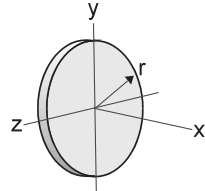
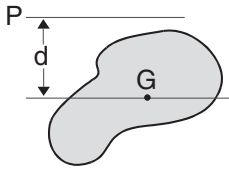
Output Torque (lb-in)	Rotation < 95°		Rotation > 100°	
	Vane Models	Rack & Pinion Models	Vane Models	Rack & Pinion Models
10000		HP10		HP10
9000				
8000				
7000				
6000				
5000		HP4.5		HP4.5
4000				
3500				
3000	PRN800D	B6714		B6714
2500		PTR322		PTR322
2000	PV46D			
1750				
1500	PRN800S		PRN800S	
1250	PV44D	PTR321, B6713		PTR321, B6713
1000				
900	PRN300D	PTR252	PV46	PTR252
800				
700	PV36D, PV42D			
600		PTR202, B6712	PV44	PTR202, B6712
500	PV42D, PRN150D	PTR251		PTR251
400	PV33D, PRN300S		PV36, PRN300S	
300		PTR201	PV42	PTR201
250		PTR152		PTR152
200	PRN150S		PV33, PRN150S	
150	PV22D, PRN50D	PTR151, B6711		PTR151, B6711
100	PRN30D			
80		PTR102	PV22	PTR102
60	PRN50S		PRN50S	
40	PRN30S	PTR101	PRN30S	PTR101
35	PV11D			
30				
25	PRNA20S		PRNA20S	
20	PV10D			
15	PRNA10S		PV11, PRNA10S	
10			PV10	
5	PRNA1S, PRNA3S		PRNA1S, PRNA3S	
0				



For inventory, lead time, and kit lookup, visit [www.pdnplu.com](http://www.pdnplu.com)

Table 4: Mass Moments of Inertia

**A**  
 Product Index,  
 Engineering Data  
 Product  
 Index  
 Engineering  
 Data

<p>Rectangular prism</p> $I_x = \frac{1}{12} m(b^2 + c^2)$ $I_y = \frac{1}{12} m(c^2 + a^2)$ $I_z = \frac{1}{12} m(a^2 + b^2)$ 	<p>Circular cylinder</p>  $I_x = \frac{1}{2} ma^2$ $I_y = I_z = \frac{1}{12} m(3a^2 + L^2)$
<p>Thin rectangular plate</p> $I_x = \frac{1}{12} m(b^2 + c^2)$ $I_y = \frac{1}{12} mc^2$ $I_z = \frac{1}{12} mb^2$ 	<p>Circular cone</p>  $I_x = \frac{3}{10} ma^2$ $I_y = I_z = \frac{3}{5} m\left(\frac{1}{4} a^2 + h^2\right)$
<p>Sphere</p> $I_x = I_y = I_z = \frac{2}{5} ma^2$ 	<p>Thin disk</p>  $I_x = \frac{1}{2} mr^2$ $I_y = I_z = \frac{1}{4} mr^2$
<p>Parallel Axis Theorem:</p> $I_p = \bar{I} + md^2$ 	<p> <math>I_p</math> = Mass moment of inertia about an axis parallel to a centroidal axis  <math>\bar{I}</math> = Mass moment of inertia about a centroidal axis  <math>m</math> = Mass  <math>d</math> = Distance between axes         </p>
<p>When acceleration is constant:</p> $\theta = \omega_0 t + \frac{1}{2} \alpha t^2$ $\theta = \omega_0 t + \frac{1}{2} \omega_t t$ $\omega = \omega_0 + \alpha t$ $\omega = (\omega_0^2 + 2\alpha\theta)^{1/2}$ $\alpha = \frac{2\theta}{t^2}$ $\alpha = \frac{(\omega_t - \omega_0)^2}{2\theta}$ $\alpha = \frac{(\omega_t - \omega_0)}{t}$	<p>When velocity is constant:</p> $\theta = \omega t$ <p> <math>t</math> = time  <math>\theta</math> = angular position  <math>\omega_t</math> = angular velocity at time = <math>t</math>  <math>\omega_0</math> = angular velocity at time = <math>0</math>  <math>\alpha</math> = angular acceleration         </p>

## Basic Velocity, Acceleration, Kinetic Energy And Torque Equations

Equations below are based on triangular velocity profile.

$$\omega_{\max} = .035 \times \frac{\Theta}{t}$$

$$\alpha = \frac{\omega_{\max}^2}{\left(\frac{\Theta}{57.3}\right)}$$

$$\alpha = \frac{\omega_{\max}}{(t/2)}$$

$$\text{K.E.} = 1/2 J_m \omega^2$$

$$T_a = \alpha \times J_m$$

$$T_f = W \times U_s \times \left( \text{Distance from pivot point to center of external bearings} \right)$$

$$T_L = \left( \text{Torque arm length to C.G. of load} \right) \times WL \times \cos(\phi)$$

Where  $\phi$  = Angle between torque arm and horizontal plane

Where:

$\Theta$  = Angle of Rotation (Degrees)

$t$  = Time to rotate through  $\Theta$  (sec)

$\omega$  = Angular velocity, radians/sec

$\alpha$  = Angular accelerations (radians/sec<sup>2</sup>)

WL = Weight of load (lbf)

$T_a$  = Torque to accelerate load (lb-in)

$U_s$  = Coefficient of static friction

$J_m^*$  = Rotational mass moment of inertia (lb-in-sec<sup>2</sup>)

$T_f$  = Torque to overcome friction (lb-in)

$T_L$  = Torque to overcome effects of gravity

\*Use "I" values from Table 4.

## Coefficients of Friction

Material*	$\mu_s$	$\mu_k$
Steel on Steel	0.80	0.40
Steel on Steel (lubricated)	0.16	0.03
Aluminum on Steel	0.45	0.30
Copper on Steel	0.22	0.22
Brass on Steel	0.35	0.19
PTFE on Steel	0.04	0.04

\*dry contact unless noted



For inventory, lead time, and kit lookup, visit [www.pdnplu.com](http://www.pdnplu.com)

A25

**Parker Hannifin Corporation**  
Pneumatic Division  
Richland, Michigan  
[www.parker.com/pneumatics](http://www.parker.com/pneumatics)

**A**

Product Index,  
Engineering Data

Product  
Index

Engineering  
Data

### Force Conversion Factors

Multiply value A by conversion factor in table to calculate value B.

A \ B	oz	lbf	N	kg(f)
oz	1	0.0625	0.2780	0.0284
lbf	16	1	4.4482	0.4536
N	3.5970	0.2248	1	0.1020
kg(f)	35.2740	2.2050	9.8068	1

### Torque Conversion Factors

Multiply value A by conversion factor in table to calculate value B.

A \ B	oz-in	lb-in	lb-ft	Nm
oz-in	1	0.0625	5.2083E-03	7.0616E-03
lb-in	16	1	0.0833	0.1130
lb-ft	192	12	1	1.356
Nm	141.61	8.8507	0.7376	1

### Rotational Inertia Conversion Factors

Multiply value A by conversion factor in table to calculate value B.

A \ B	oz-in <sup>2</sup>	oz-in-sec <sup>2</sup>	lb-in <sup>2</sup>	lb-in-sec <sup>2</sup>	lb-ft <sup>2</sup>	lb-ft-sec <sup>2</sup>	kg-m <sup>2</sup>	kg-m-sec <sup>2</sup>	kg-cm <sup>2</sup>	kg-cm-sec <sup>2</sup>
oz-in <sup>2</sup>	1	2.5900E-03	6.2500E-02	1.6190E-04	4.3403E-04	1.3490E-05	1.8290E-05	1.8650E-06	1.8290E-01	1.8650E-04
oz-in-sec <sup>2</sup>	3.8610E+02	1	2.4130E+01	6.2500E-02	1.6760E-01	5.2080E-03	7.0620E-03	7.2010E-04	7.0620E+01	7.2010E-02
lb-in <sup>2</sup>	1.6000E+01	4.1442E-02	1	2.5900E-03	6.9444E-03	2.1583E-04	2.9260E-04	2.9840E-05	2.9260E+00	2.9840E-03
lb-in-sec <sup>2</sup>	6.1767E+03	1.6000E+01	3.8610E+02	1	2.6810E+00	8.3333E-02	1.1300E-01	1.1520E-02	1.1300E+03	1.1520E+00
lb-ft <sup>2</sup>	2.3040E+03	5.9668E+00	1.4400E+02	3.7300E-01	1	3.1080E-02	4.2140E-02	4.2970E-03	4.2140E+02	4.2970E-01
lb-ft-sec <sup>2</sup>	7.4129E+04	1.9201E+02	4.6333E+03	1.2000E+01	3.2175E+01	1	1.3560E+00	1.3824E-01	1.3560E+04	1.3824E+01
kg-m <sup>2</sup>	5.4675E+04	1.4160E+02	3.4176E+03	8.8496E+00	2.3730E+01	7.3746E-01	1	1.0190E-01	1.0000E+04	1.0190E+01
kg-m-sec <sup>2</sup>	5.3619E+05	1.3887E+03	3.3512E+04	8.6806E+01	2.3272E+02	7.2338E+00	9.8135E+00	1	9.8130E+04	1.0000E+02
kg-cm <sup>2</sup>	5.4675E+00	1.4160E-02	3.4176E-01	8.8496E-04	2.3730E-03	7.3746E-05	1.0000E-04	1.0191E-05	1	1.0190E-03
kg-cm-sec <sup>2</sup>	5.3619E+03	1.3887E+01	3.3512E+02	8.6806E-01	2.3272E+00	7.2338E-02	9.8135E-02	1.0000E-02	9.8135E+02	1

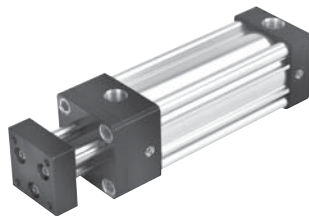
### Length/Distance Conversion Factors

Multiply value A by conversion factor in table to calculate value B.

A \ B	in	ft	mm	cm	m
in	1	0.0833	25.4	2.54	0.0254
ft	12	1	304.8	30.48	0.3048
mm	0.03937	0.00328	1	0.1	0.001
cm	0.3937	0.03281	10	1	0.01
m	39.37	3.281	1000	100	1



For inventory, lead times, and kit lookup, visit [www.pdnplu.com](http://www.pdnplu.com)



## NFPA Pneumatic Cylinders

### 4MA / 4ML Series - Non-Lube NFPA Air Cylinders

#### 1-1/2" to 5" Bore Sizes

Features / Ordering Information	B2-B3
Mounting Styles	B4
Body Orientations	B5
Specifications	B6-B8
Dimensional Data	B9-B16
Accessories / Service Kits	B34-B35

#### 6" to 8" Bore Sizes

Features / Ordering Information	B18-B19
Mounting Styles	B20
Specifications	B21-B23
Dimensional Data	B24-B33
Accessories / Service Kits	B34-B35

#### 4MAJ Series (Rod Lock Option)

Features / Ordering Information	B37-B40
Mounting Styles	B41
Specifications	B42-B43
Dimensional Data	B44-B61

ACVB Option - Valve Mounted to Cylinder B62-B71

LPSO Option - Linear Position Sensor B72-B76

Standard Options B77-B79

Accessories B80-B81

Maintenance and Service Kits B82-B91

## Non-Rotating Pneumatic Cylinders

### 2MNR Non-Rotating

Features / Ordering Information	B92-B93
Mounting Styles	B94
Specifications / Technical Data	B95-B96
Dimensional Data	B97-B102
Accessories / Service Kits	B103

## ISO Pneumatic Cylinders

### P1D ISO Pneumatic Cylinders

Features	B104
Options	B105-B107
Common Part Numbers / Ordering Information	B108-B109
Specifications	B110-B111
Technical Data	B112-B114
Dimensional Data	B115-B120
Rod End Dimensions (Mounting and Rod End Kits)	B121
Tandem and Duplex Cylinders	B122
Accessories / Service Kits	B123-B132

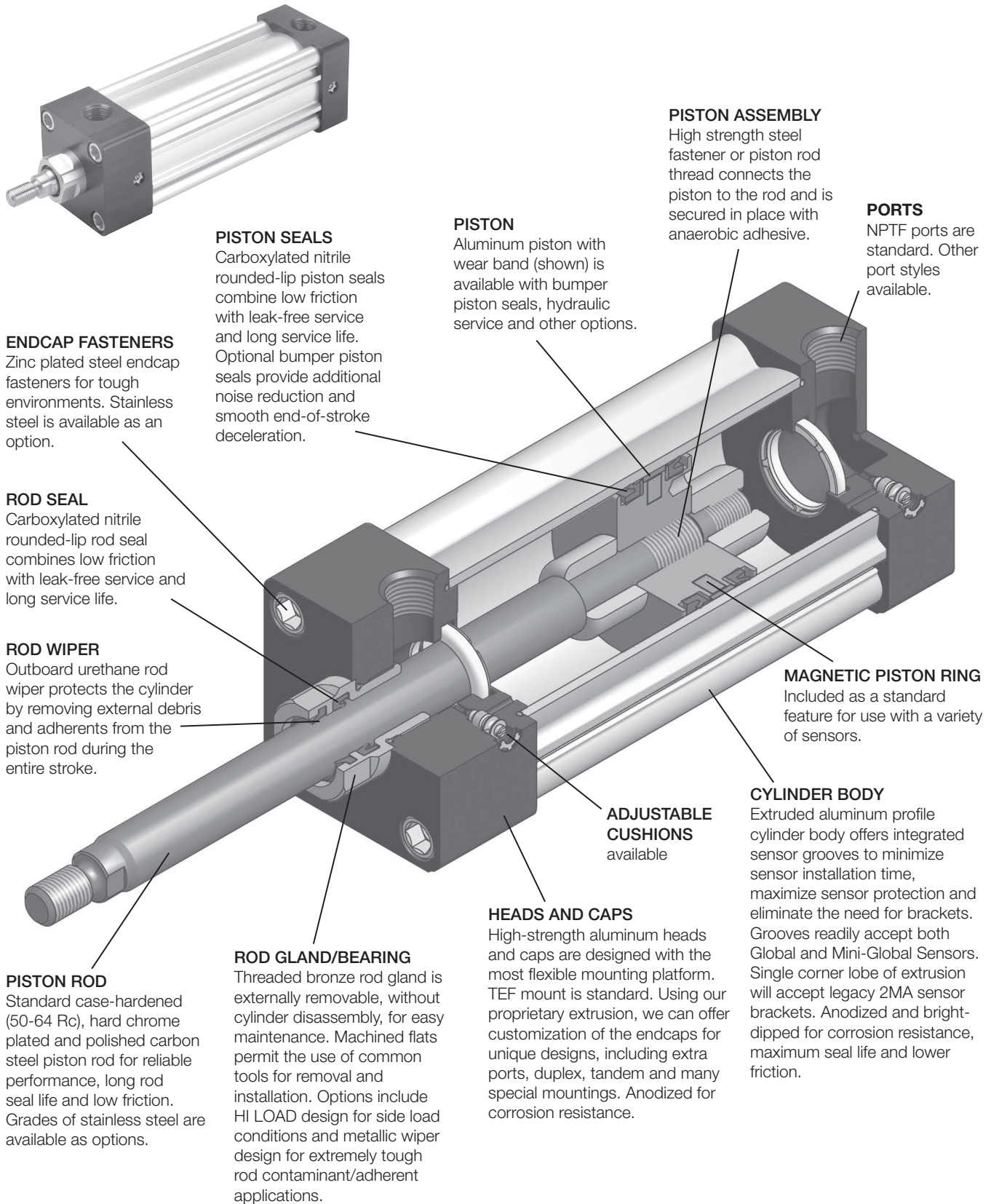
**B**

**Tie Rod Pneumatic  
Cylinders**

**Features**

**4MA/4ML Series – 1-1/2" to 5" Bore Size**

<b>B</b>	Tie Rod Pneumatic Cylinders
	Series
4MA	Series
4MAJ	Series
2MNR	Series
ACVB	Option
LPSO	Option
P1D	Series



For a complete list of 4MA options, please see pages B3 and B8.



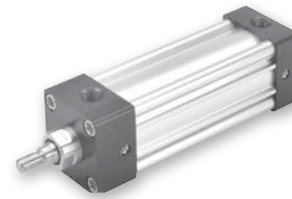
For inventory, lead times, and kit lookup, visit [www.pdnplu.com](http://www.pdnplu.com)

# Tie Rod Pneumatic Cylinders

## 4MA/4ML Series – 1-1/2" to 5" Bore Size

### Features

- Industry leading aluminum NFPA interchangeable cylinder with flexible construction
- Bore sizes – 1-1/2", 2", 2-1/2", 3-1/4", 4" and 5"
- Removable bronze alloy gland/bearing for easy maintenance
- Available in any practical stroke length
- 20 standard mounting styles available
- Extruded-profile aluminum body with integrated switch grooves
- Single rod end or double rod ends
- Cushions – standard and adjustable at both ends, optional non-cushioned
- RoHS compliant



### Operating information

	4MA	4ML
Operating pressure:	250 PSIG (17 bar) maximum air service	400 PSIG (27 bar) maximum hydraulic service
Temperature range –		
Standard seals	-10°F to 165°F (-23°C to 74°C)	
Fluorocarbon seals	-10°F to 250°F (-23°C to 121°C)	
Low temperature seals	-50°F to 150°F (-46°C to 66°C)	
Filtration requirements:	40 micron, dry filtered air	Filtered hydraulic oil

### Ordering information

<b>2.00</b>	<b>J</b>	<b>4MA</b>	<b>U</b>	<b>1</b>	<b>4</b>	<b>A</b>	<b>6.000</b>
<b>Bore size</b> 1.50 <sup>1</sup> 2.00 2.50 3.25 4.00 5.00	<b>Double rod cylinder</b> <sup>12</sup> Specify "K" only if double rod cylinder is required.	<b>Series</b> 4MA Air service 4ML Hydraulic service <sup>2</sup>	<b>Ports</b> U NPTF R BSPP B BSPT T SAE	<b>Piston rod number</b> Specify rod code number for required diameter. <sup>8, 2</sup>	<b>Special modification</b> Specify "S" only for special modification other than rod end, and then describe modification in item notes. (Includes 4MA with Linear Position Sensor Option) <sup>7</sup>	<b>Cushion cap end</b> Blank Non-cushioned cap end C Cushioned cap end (not available for 4ML)	<b>Stroke length</b> Specify stroke length required in inches. <sup>11</sup>
<b>Mounting style</b> Specify mounting style code (see table on following page).						<b>Piston rod thread type</b> A Standard (UNF unified thread) W BSF British fine M* Metric	
<b>Cushion head end</b> Blank Non-cushioned head end C Cushioned head end (not available for 1.50" bore with 1" rod or 4ML)			<b>Seals</b> Blank Standard (nitrile seals) V Fluorocarbon seals <sup>4</sup> E Fluorocarbon rod wiper and rod seal only <sup>5</sup> 4 Low temperature seals <sup>4</sup> M Metallic rod wiper, nitrile seals <sup>6</sup>			<b>Rod material and gland code</b> Blank Standard rod and gland H Standard rod and HI LOAD gland Y 17-4 PH stainless steel rod and standard gland Z 17-4 PH stainless steel rod and HI LOAD gland J 303 stainless steel rod and standard gland <sup>10</sup> K 303 stainless steel rod and HI LOAD gland <sup>10</sup> S 316 stainless steel rod and standard gland <sup>10</sup> T 316 stainless steel rod and HI LOAD gland <sup>10</sup>	
<b>Cylinder construction</b> Blank* Standard (extruded body, standard round lobe orientation) A* Extruded body, round lobe orientation rotated 90 degrees from standard N* Extruded body, round lobe orientation rotated 180 degrees from standard Z* Extruded body, round lobe orientation rotated 270 degrees from standard T Aluminum round tube and carbon steel tie rods & nuts				<b>Piston rod thread style</b> 4 Small male 8 Intermediate male 9 Short female 55 For use with split coupler <sup>9</sup> 3 Special (and specify all dimensions required) 6 Full male			
<b>Piston type</b> <sup>2</sup> Blank Lipseals and magnetic ring (legacy) (standard for 4ML) 1 Lipseals, no magnetic ring (legacy) 2 Lipseals, no magnetic ring (aluminum piston) 3 Lipseals and magnetic ring (aluminum piston) (standard for 4ML) 4 Bumper seals, no magnetic ring 6 Bumper seals and magnetic ring B Lipseals, 1/4" thick bumpers both ends <sup>3</sup> H Lipseals, 1/4" thick bumper head end <sup>3</sup> C Lipseals, 1/4" thick bumper cap end <sup>3</sup> D Lipseals and magnetic ring, 1/4" thick bumpers both ends <sup>3</sup> F Lipseals and magnetic ring, 1/4" thick bumper head end <sup>3</sup> R Lipseals and magnetic ring, 1/4" thick bumper cap end <sup>3</sup>							

\* See table on page B5. Only applies to 1-1/2" to 4" bore size.

<sup>1</sup> Not available with Linear Position Sensor Option (LPSO).  
<sup>2</sup> Piston Types (blank), 1, 4 and 6 not available for 4ML. Piston Types (blank) and 1 not available for oversize rod numbers 2 and 3. Seals option V only available with Piston Types 2 and 4. Seals option 4 only available with Piston Types 2 and 3.  
<sup>3</sup> Addition of 1/4" bumper results in a 1/4" stroke loss per bumper, per end. For example, a 6" stroke cylinder with 1/4" bumpers at both ends (option B) has an effective stroke of 5-1/2".  
<sup>4</sup> Reed and solid-state sensors only available with standard seals or options E and M. See footnote 2.  
<sup>5</sup> Used for external chemical compatibility applications, not high temperature.  
<sup>6</sup> If fluorocarbon seals are required with this option, please place an "S" for special in the Special Modification field and specify the "fluorocarbon seals and metallic rod wiper" in the item notes.  
<sup>7</sup> For Linear Position Sensor Option (LPSO), please include the following information for the Special Modification item notes:  
 a. Sensor part number reference LPSO section  
 b. Sensor position  
 c. Port position (if other than position 1)  
 d. Length of stop tubing, gross stroke and net stroke (if required)  
 Also, Piston Type option (blank), 3, 6, D, F or R is required.  
<sup>8</sup> Review Piston Rod Selection Chart, please reference page A14 to determine proper piston rod diameter.  
<sup>9</sup> For additional information regarding this style, please reference page B77. If non-standard Rod Material and Gland Code is required with this option, please place an "S" for special in the Special Modification field and specify Rod Material and Gland Code in the item notes.  
<sup>10</sup> Not available for 4MAJ.  
<sup>11</sup> If a stop tube is required, specify gross stroke (net stroke + stop tube) in the model number, then place an "S" for special in the Special Modification field and specify the stop tube length in the item notes.

For ordering purposes, when special options or common modifications are requested, the factory will assign a sequential part number in place of the model number.

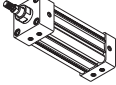
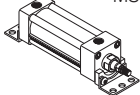
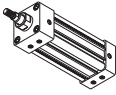
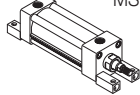
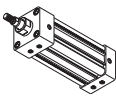
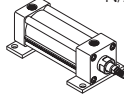
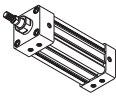
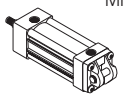
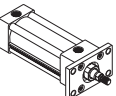
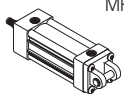
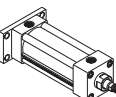
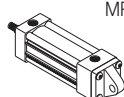
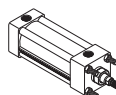
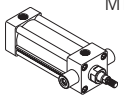
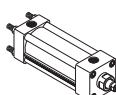
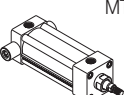
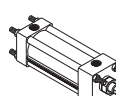
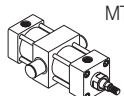
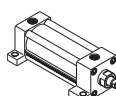
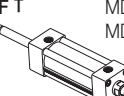


For inventory, lead time, and kit lookup, visit [www.pdnplu.com](http://www.pdnplu.com)

## Mounting Styles

## Tie Rod Pneumatic Cylinders 4MA/4ML Series – 1-1/2" to 5" Bore Size

### 4MA/4ML Mounting Styles for 1-1/2" to 5" Bore

Mounting style	NFPA mounting	Description	Bore size	Mounting style	NFPA mounting	Description	Bore size	
 TEF	MX5/MS4	Sleeve Nut with Side Tap (standard mount)	4MA/4ML w/LPSO w/LPSO w/stop tube	1-1/2 - 5*	2 - 5 2 - 5	 CB	MS1 Side End Angle 4MA/4ML w/LPSO w/LPSO w/stop tube	1-1/2 - 5 2 - 5 2 - 5
 T	MX0	No Mount (same construction as TEF)	4MA/4ML w/LPSO w/LPSO w/stop tube	1-1/2 - 5 2 - 5 2 - 5	 G	MS7 Side End Lug 4MA/4ML w/LPSO w/LPSO w/stop tube	1-1/2 - 4* 2 - 4 2 - 4	
 TE	MX5	Sleeve Nut (same construction as TEF)	4MA/4ML w/LPSO w/LPSO w/stop tube	1-1/2 - 5 2 - 5 2 - 5	 NB	N/A Base Bar 4MA/4ML w/LPSO w/LPSO w/stop tube	1-1/2 - 4* 2 - 4 2 - 4	
 F	MS4	Side Tap (same construction as TEF)	4MA/4ML w/LPSO w/LPSO w/stop tube	1-1/2 - 5* 2 - 5 2 - 5	 BB	MP1 Cap Fixed Clevis 4MA/4ML w/LPSO w/LPSO w/stop tube	1-1/2 - 5 2 - 5** 2 - 5**	
 J	MF1	Head Rectangular Flange	4MA/4ML w/LPSO w/LPSO w/stop tube	1-1/2 - 5 2 - 5** 2 - 5	 BC	MP2 Cap Detachable Clevis 4MA/4ML w/LPSO w/LPSO w/stop tube	1-1/2 - 5 2 - 5** 2 - 5**	
 H	MF2	Cap Rectangular Flange	4MA/4ML w/LPSO w/LPSO w/stop tube	1-1/2 - 5 2 - 5** 2 - 5**	 BE	MP4 Cap Detachable Eye 4MA/4ML w/LPSO w/LPSO w/stop tube	1-1/2 - 5 2 - 5** 2 - 5**	
 TB	MX3	Tie Rods Extended Head End	4MA/4ML w/LPSO w/stop tube	1-1/2 - 5 2 - 5	 D	MT1 Head Trunnion 4MA/4ML w/LPSO w/LPSO w/stop tube	1-1/2 - 5* 2 - 5 2 - 5	
 TC	MX2	Tie Rods Extended Cap End	4MA/4ML	1-1/2 - 5	 DB	MT2 Cap Trunnion 4MA/4ML w/LPSO w/LPSO w/stop tube	1-1/2 - 5 2 - 5** 2 - 5**	
 TD	MX1	Tie Rods Extended Both Ends	4MA/4ML	1-1/2 - 5	 DD	MT4 Intermediate Trunnion 4MA/4ML	1-1/2 - 5	
 C	MS2	Side Lug	4MA/4ML w/LPSO w/LPSO w/stop tube	1-1/2 - 5 2 - 5 2 - 5	 KTEF †	MDX5/ MDS4 Double Rod End, TEF Mount 4MA/4ML w/LPSO w/LPSO w/stop tube	1-1/2 - 5 2 - 5 2 - 5	

\* Not available for 1-1/2" bore with 1" rod.

\*\* May interfere with mounting. Please provide clearance for Linear Sensor overhang (see page B73).

† Double rod end cylinders can be ordered with head mountings, i.e. KJ.

#### Sensors

See section L for sensors.



#### Kits & Accessories

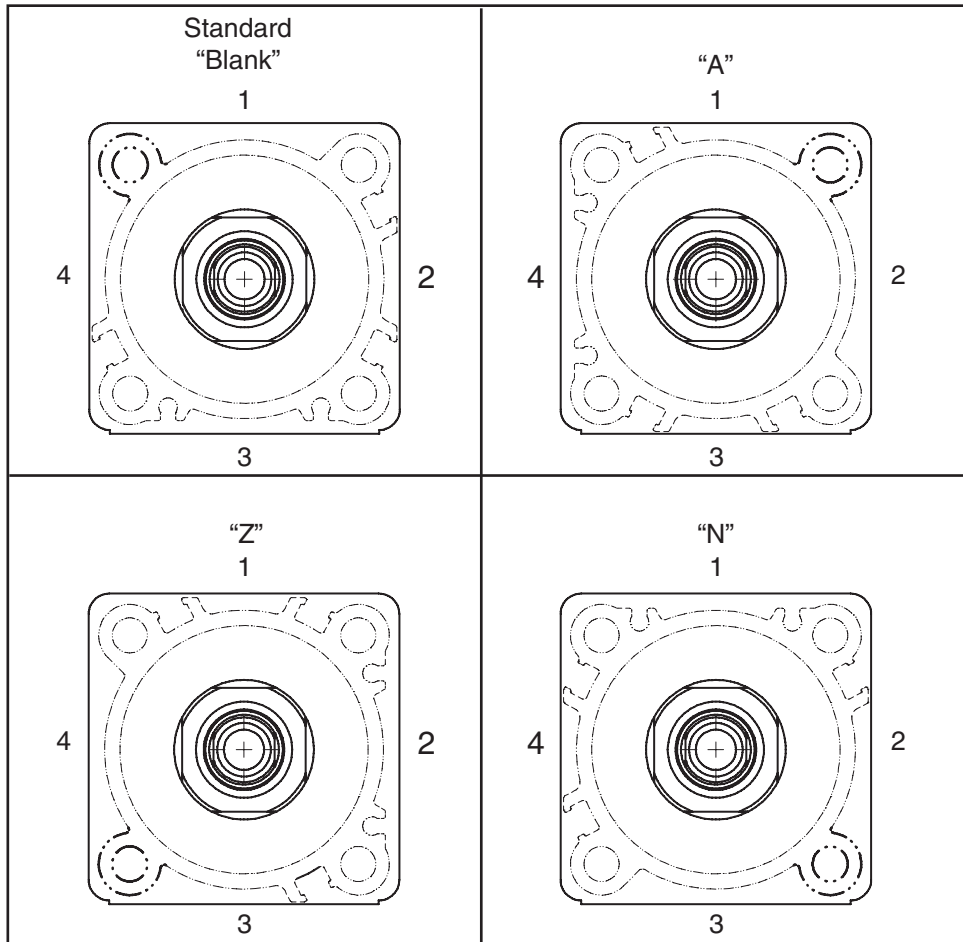
See page B34.



For inventory, lead times, and kit lookup, visit [www.pdnplu.com](http://www.pdnplu.com)



**4MA Extruded Cylinder Body Orientation Options\***



\* Only applies to 1-1/2" to 4" Bore

B
Tie Rod Pneumatic Cylinders
4MA Series
4MAJ Series
2MNR Series
ACVB Option
LPSO Option
P1D Series



For inventory, lead time, and kit lookup, visit [www.pdnplu.com](http://www.pdnplu.com)

## Specifications

## Tie Rod Pneumatic Cylinders 4MA/4ML Series – 1-1/2" to 5" Bore Size

### General Specifications

- NFPA interchangeable
  - Bore sizes – 1-1/2", 2", 2-1/2", 3-1/4", 4" and 5"
  - Strokes – available in any practical stroke length
  - Rod diameters – 5/8", 1" and 1-3/8"
  - Rod end styles – 4 standard, specials available
  - Single rod end or double rod ends
  - Cushions – optional and adjustable at either end or both ends (N/A for 4ML Hydraulic Version)
  - Operating pressure –  
4MA = 250 PSIG (17 bar) maximum air service  
4ML = 400 PSIG (27 bar) maximum hydraulic service
  - Media – 4MA = dry, filtered air  
4ML = filtered hydraulic oil
  - Temperature range –  
-10°F to 165°F (-23°C to 74°C) standard seals  
-10°F to 250°F (-23°C to 121°C) fluorocarbon seals option  
-50°F to 150°F (-46°C to 66°C) low temperature seals option
  - Mounting styles – 20 standard styles
  - RoHS compliant
- For material options, including seals, piston rods and glands, please see Material Specifications on next page.

### Cylinder Weights – 4MA / 4ML Cylinders

Bore (inch)	Rod (inch)	No mount single rod 4MA/4ML		No mount double rod	
		Base wt. (lbs.)	Per inch (lbs.)	Base wt. (lbs.)	Per inch (lbs.)
1-1/2	0.625	1.73	0.20	2.16	0.28
	1.00	2.99	0.35	4.34	0.58
2	0.625	2.40	0.21	3.05	0.30
	1.00	2.99	0.35	4.34	0.58
2-1/2	0.625	3.25	0.23	3.96	0.31
	1.00	4.06	0.37	5.74	0.60
3-1/4	1.00	6.45	0.42	7.65	0.64
	1.375	7.93	0.62	11.46	1.05
4	1.00	8.80	0.49	10.32	0.71
	1.375	10.29	0.69	14.37	1.12
5	1.00	13.20	0.61	15.84	0.84
	1.375	14.72	0.81	18.89	1.24

### Standard Cushion Position

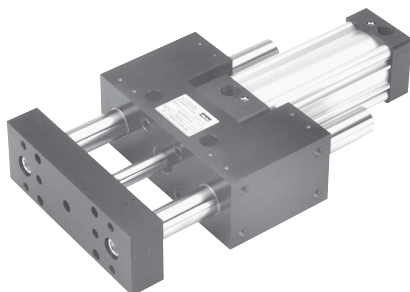
Mounting Code	Position
All except D, DB, DD	2
D, DB, DD	3

### Standard Port Sizes

Bore	NPTF	BSPT	BSPP	SAE
1-1/2	3/8	Rc3/8	G3/8	6
2	3/8	Rc3/8	G3/8	6
2-1/2	3/8	Rc3/8	G3/8	6
3-1/4	1/2	Rc1/2	G1/2	10
4	1/2	Rc1/2	G1/2	10
5	1/2	Rc1/2	G1/2	10

### Mounting Weight Adders

Bore (inch)	Mounting style, weight (lbs)							
	J, H	D, DB	BB	CB, G	DD	BE	C	BC
1-1/2	0.51	0.50	0.15	0.36	1.70	0.23	0.15	0.20
2	0.76	0.50	0.26	0.65	2.38	0.32	0.15	0.29
2-1/2	1.13	0.50	0.38	1.05	3.00	0.42	0.15	0.41
3-1/4	2.76	0.50	0.98	1.38	5.35	1.26	0.35	1.06
4	4.05	0.50	1.35	2.20	6.75	1.62	0.35	1.49
5	6.46	0.50	1.20	4.29	8.77	1.26	0.57	2.41



For a guided version of the 4MA or 4ML Series, please see the HB Series in Section E.

## Material Specifications

### Standard Temperatures and Applications

Head and cap	Black anodized aluminum alloy
Head and cap screws	Zinc plated steel alloy
Cylinder body	Clear anodized aluminum alloy
Piston rod	Case-hardened, chrome plated carbon steel
Rod seal	Carboxylated nitrile (Nitroxile)
Rod wiper	Molythane
Rod bearing (gland)	Bronze alloy
Piston	Aluminum alloy
Piston seals	Carboxylated nitrile (Nitroxile)
Piston bearing	Composite (for standard piston) MolyGard™ (for aluminum piston)
Magnetic ring	Plastic-bound magnetic material
Piston fastener	Piston rod for aluminum piston
O-rings	Nitrile
End seals	Nitrile
Cushion seals	Urethane
Cushion needle valves	Stainless steel
Tie-rods/studs	Blackened carbon steel 1018 (some mounts)
Tie-rod nuts	Steel alloy, SAE J995 Grade 8 (some mounts)

## Tie Rod Pneumatic Cylinders 4MA/4ML Series – 1-1/2" to 5" Bore Size

### Material and Part Changes

#### 4MA Options

High temperatures (-10°F to 250°F)	All seals and wiper are fluorocarbon Aluminum piston without magnetic ring
Low temperatures (-50°F to 150°F)	Rod seal, piston seals, o-rings and end seals are low temperature-rated nitrile

#### 4ML Hydraulic Version

Hydraulic service (general)	Cushions and bumper piston seals not available
Hydraulic service (std temp)	Polyurethane TS-2000 rod seal and nitrile piston seals (for hydraulic use)
Hydraulic service (high temp)	Fluorocarbon TS-2000 rod seal; wiper and all seals are fluorocarbon (for hydraulic use)

#### Other Standard Options

Cylinder seal options	Fluorocarbon for high temperatures or chemical compatibility Other seal options available, please consult factory
Bumper piston seal options (4MA only, N/A for 4ML)	Carboxylated nitrile (Nitroxile) for standard temperatures Fluorocarbon for high temperatures or chemical compatibility
1/4" thick bumpers option	Urethane
Piston rod material options	Case-hardened, chrome plated carbon steel (standard) 17-4 PH stainless steel, chrome plated 303 stainless steel, chrome plated (N/A for 4ML) 316 stainless steel, chrome plated (N/A for 4ML) For stainless steel without chrome plating, please consult factory
HI LOAD gland option	Composite bearing pressed into bronze alloy gland
Metallic rod scraper option	Dual high strength bronze wipers with PTFE (5/8" rod only) or fluorocarbon energizer

**B**

Tie Rod Pneumatic Cylinders

4MA Series

4MAJ Series

2MNR Series

ACVB Option

LPSO Option

P1D Series



For inventory, lead time, and kit lookup, visit [www.pdnplu.com](http://www.pdnplu.com)

B7

**Parker Hannifin Corporation**  
Pneumatic Division  
Richland, Michigan  
[www.parker.com/pneumatics](http://www.parker.com/pneumatics)

**How to Select a 1-1/2" to 5" Bore 4MA Cylinder**

Parker cylinders are available based on air or hydraulic operating pressure. The many styles, sizes and optional features available assure that your application requirements are precisely met. To select a cylinder, follow these simple steps:

- Step 1 - **Determine the correct cylinder bore size** necessary to achieve required force using the available operating pressure.
- Step 2 - **Determine the series cylinder to use**, based on operating pressure.
- Step 3 - **Turn to the appropriate cylinder selection section.** Select the mounting style that fits your installation needs. Determine the bore and rod sizes available for the model you select. Then complete model selection.
  - Choose a rod end style and the desired rod end accessories.
  - Size the cylinder to meet your application requirements.
- Step 4 - **Consider the following conditions** which may require further modifications to the cylinder you have selected.

Application Condition	Check the Following
Quick Starts or Stops	Confirm that determined thrust is sufficient to accelerate or decelerate cylinder and load within prescribed distance. Optional cushions should be used to reduce shock during deceleration, check that peak pressures will be within tolerable limits.
Long Push Stroke	Check whether stop tube is required to prevent excessive bearing loads and wear.
High-column Loading Long Push Stroke	Determine if standard size piston rod is strong enough to accommodate intended load. See Application Engineering section for recommendations.
Long Horizontal Stroke	Determine if standard size piston rod is strong enough to accommodate intended load.
High Operating Temperatures	For temperatures between 165°F and 250°F use 4MA or 4ML cylinder with high temperature seals.

**General Options and Modifications:**

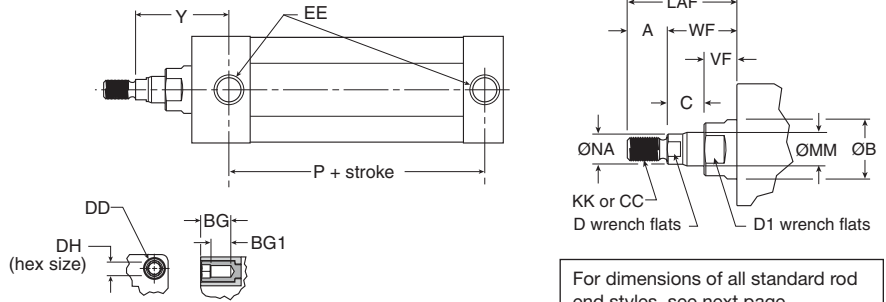
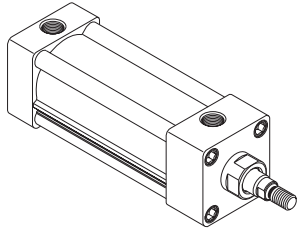
- Adjustable Cushions
- Non-Magnetic Piston (magnetic ring standard)
- Piston Bumper Seals
- Piston Bumpers (1/4" thick)
- Port and Adjustable Cushion Relocation
- Port Thread Styles
- Multiple Ports
- Special Heads, Caps, Pistons and Mounts
- Double Rod End
- Oversize Rod Diameters
- Rod End Modifications
- Rod Materials (grades of stainless steel)
- Fluorocarbon Rod Wiper and Rod Seal only
- Fluorocarbon Seals (all cylinder seals)
- Metallic Rod Wiper
- HI LOAD Gland Assembly
- Stop Tube
- Mixed Mountings
- Round Tube and Tie Rod Construction
- Stainless Steel Fasteners/Tie Rods
- Shock Absorber on Cap End
- NuCushion Bumpers
- Hydro-Check unit for smooth hydraulic control
- Air Cylinder/Valve Combination (ACVB)
- Adjustable Point Sensors (order separately)
- Continuous Linear Position Sensing (LPSO)
- High Temperature Service (to 250°F)
- Low Temperature Service (to -50°F)
- Hydraulic Service (4ML) (400 PSIG)
- Rod lock version (see 4MAJ)

**B**  
 Tie Rod Pneumatic Cylinders  
 4MA Series  
 4MAJ Series  
 2MNR Series  
 ACVB Option  
 LPSO Option  
 P1D Series



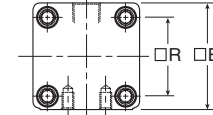
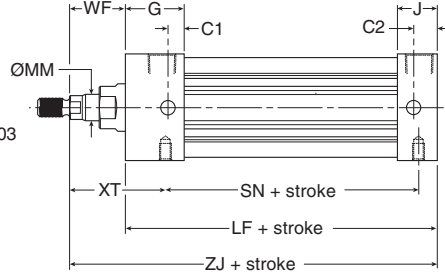
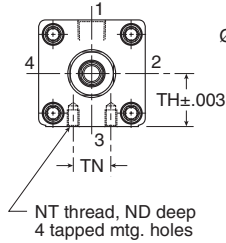
For inventory, lead times, and kit lookup, visit [www.pdnplu.com](http://www.pdnplu.com)

**Single Rod**  
**(Styles TEF, T, TE and F)**



For dimensions of all standard rod end styles, see next page.

1-1/2" bore with 1" rod is TE mount, F mount not available.  
 1-1/2" bore with 1" rod cannot have a cushion at head end.



**Styles TEF, T, TE and F**

Bore size	Rod no.	Rod dia.		Thread			Style 4													EE (NPTF)
		MM	CC	Style 8	Style 9 & 9	Style 6	A	AA	B	BG	BG1	C	C1	C2	D	D1	DD	DH	E	
1-1/2	1	5/8	1/2 - 20	7/16 - 20	5/8 - 18	0.750	2.020	1.124	0.562	0.374	0.385	1.000	0.500	1/2	1	1/4 - 28	1/4	2.000	3/8	
	2*	1	7/8 - 14	3/4 - 16	1 - 14	1.125	2.020	1.499	0.562	0.374	0.510	-	0.500	7/8	1-3/8	1/4 - 28	1/4	2.000	3/8	
2	1	5/8	1/2 - 20	7/16 - 20	5/8 - 18	0.750	2.600	1.124	0.562	0.362	0.385	1.000	0.562	1/2	1	5/16 - 24	5/16	2.500	3/8	
	3	1	7/8 - 14	3/4 - 16	1 - 14	1.125	2.600	1.499	0.562	0.362	0.510	1.000	0.562	7/8	1-3/8	5/16 - 24	5/16	2.500	3/8	
2-1/2	1	5/8	1/2 - 20	7/16 - 20	5/8 - 18	0.750	3.100	1.124	0.562	0.362	0.385	1.000	0.594	1/2	1	5/16 - 24	5/16	3.000	3/8	
	3	1	7/8 - 14	3/4 - 16	1 - 14	1.125	3.100	1.499	0.562	0.362	0.510	1.000	0.594	7/8	1-3/8	5/16 - 24	5/16	3.000	3/8	
3-1/4	1	1	7/8 - 14	3/4 - 16	1 - 14	1.125	3.900	1.499	0.700	0.500	0.510	1.188	0.719	7/8	1-3/8	3/8 - 24	3/8	3.750	1/2	
	3	1-3/8	1-1/4 - 12	1 - 14	1-3/8 - 14	1.625	3.900	1.999	0.700	0.500	0.635	1.188	0.719	1-1/8	1-7/8	3/8 - 24	3/8	3.750	1/2	
4	1	1	7/8 - 14	3/4 - 16	1 - 14	1.125	4.700	1.499	0.700	0.500	0.510	1.188	0.719	7/8	1-3/8	3/8 - 24	3/8	4.500	1/2	
	3	1 3/8	1-1/4 - 12	1 - 14	1-3/8 - 14	1.625	4.700	1.999	0.700	0.500	0.635	1.188	0.719	1-1/8	1-7/8	3/8 - 24	3/8	4.500	1/2	
5	1	1	7/8 - 14	3/4 - 16	1 - 14	1.125	5.800	1.499	0.781	0.531	0.510	1.188	0.813	7/8	1-3/8	1/2 - 20	1/2	5.500	1/2	
	3	1 3/8	1-1/4 - 12	1 - 14	1-3/8 - 14	1.625	5.800	1.999	0.781	0.531	0.635	1.188	0.813	1-1/8	1-7/8	1/2 - 20	1/2	5.500	1/2	

Bore size	Rod no.	Rod dia.		Style 4													Add stroke			
		MM	G	J	LAF	NA	ND	NT	R	TH	TN	VF	WF	XT	Y	LF	P	SN	ZJ	
1-1/2	1	5/8	1.438	0.938	1.750	0.563	0.375	1/4 - 20	1.430	0.993	0.625	0.615	1.000	1.938	1.875	3.625	2.313	2.250	4.625	
	2*	1	1.438	0.938	2.500	0.938	-	-	1.430	0.993	-	0.865	1.375	-	2.250	3.625	2.313	-	5.000	
2	1	5/8	1.375	0.937	1.750	0.563	0.438	5/16 - 18	1.840	1.243	0.875	0.615	1.000	1.938	1.875	3.625	2.313	2.250	4.625	
	3	1	1.375	0.937	2.500	0.938	0.375	5/16 - 18	1.840	1.243	0.875	0.865	1.375	2.313	2.250	3.625	2.313	2.250	5.000	
2-1/2	1	5/8	1.344	0.938	1.750	0.563	0.625	3/8 - 16	2.190	1.493	1.250	0.615	1.000	1.938	1.938	3.750	2.375	2.375	4.750	
	3	1	1.344	0.938	2.500	0.938	0.625	3/8 - 16	2.190	1.493	1.250	0.865	1.375	2.313	2.313	3.750	2.375	2.375	5.125	
3-1/4	1	1	1.594	1.125	2.500	0.938	0.750	1/2 - 13	2.760	1.868	1.500	0.865	1.375	2.438	2.438	4.250	2.625	2.625	5.625	
	3	1-3/8	1.594	1.125	3.250	1.313	0.750	1/2 - 13	2.760	1.868	1.500	0.990	1.625	2.688	2.688	4.250	2.625	2.625	5.875	
4	1	1	1.594	1.125	2.500	0.938	0.750	1/2 - 13	3.320	2.243	2.063	0.865	1.375	2.438	2.438	4.250	2.625	2.625	5.625	
	3	1-3/8	1.594	1.125	3.250	1.313	0.750	1/2 - 13	3.320	2.243	2.063	0.990	1.625	2.688	2.688	4.250	2.625	2.625	5.875	
5	1	1	1.594	1.219	2.500	0.938	0.938	5/8 - 11	4.100	2.743	2.688	0.865	1.375	2.438	2.438	4.500	2.875	2.875	5.875	
	3	1 3/8	1.594	1.219	3.250	1.313	0.938	5/8 - 11	4.100	2.743	2.688	0.990	1.625	2.688	2.688	4.500	2.875	2.875	6.125	

\* NOTE - 1-1/2" bore with 1" rod is TE mount, F mount not available.  
 1-1/2" bore with 1" rod cannot have a cushion at head end.

**B**

Tie Rod Pneumatic Cylinders

4MA Series

4MAJ Series

2MNR Series

ACVB Option

LPSO Option

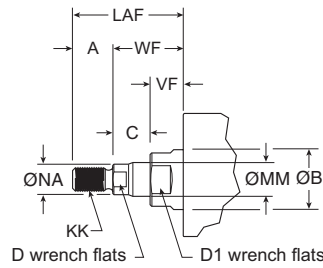
P1D Series



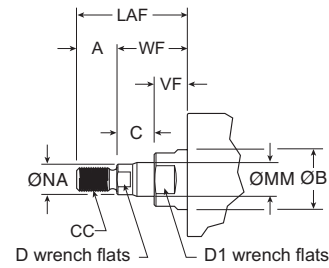
For inventory, lead time, and kit lookup, visit [www.pdnplu.com](http://www.pdnplu.com)

**Thread Style Rod End**

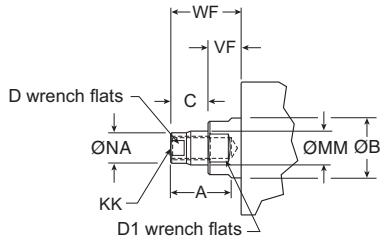
**Thread Style 4**  
(NFPA Style SM)  
Small Male



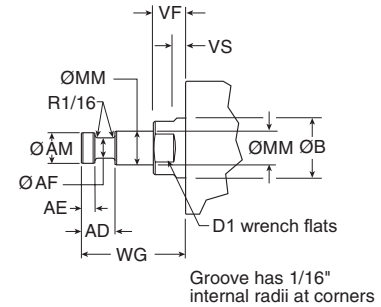
**Thread Style 8**  
(NFPA Style IM)  
Intermediate Male



**Thread Style 9**  
(NFPA Style SF)  
Short Female



**Thread Style 55**  
For use with Split Coupler  
(please reference page B77 for more information)



**Thread Style 3 - "Special Thread"**

Special threads, rod extensions, rod eyes, blanks, etc. are also available. To order, specify "Style 3" and give desired dimensions for KK or CC, A and W or WF. If otherwise special, please supply dimensioned sketch.

**Rod End Dimensions**

Bore size	Rod no.	Rod dia. MM	Thread																
			Style 8 CC	Style 4 & 9 KK	Style 6	A	AD	AE	AF	AM	B	C	D	D1	LAF	NA	VF	WF	WG
1-1/2	1	5/8	1/2 - 20	7/16 - 20	5/8 - 18	0.750	0.625	0.250	0.375	0.570	1.124	0.385	1/2	1	1.750	0.563	0.615	1.000	1.750
	2	1	7/8 - 14	3/4 - 16	1 - 14	1.125	0.938	0.375	0.688	0.950	1.499	0.510	7/8	1-3/8	2.500	0.938	0.865	1.375	2.375
2	1	5/8	1/2 - 20	7/16 - 20	5/8 - 18	0.750	0.625	0.250	0.375	0.570	1.124	0.385	1/2	1	1.750	0.563	0.615	1.000	1.750
	3	1	7/8 - 14	3/4 - 16	1 - 14	1.125	0.938	0.375	0.688	0.950	1.499	0.510	7/8	1-3/8	2.500	0.938	0.865	1.375	2.375
2-1/2	1	5/8	1/2 - 20	7/16 - 20	5/8 - 18	0.750	0.625	0.250	0.375	0.570	1.124	0.385	1/2	1	1.750	0.563	0.615	1.000	1.750
	3	1	7/8 - 14	3/4 - 16	1 - 14	1.125	0.938	0.375	0.688	0.950	1.499	0.510	7/8	1-3/8	2.500	0.938	0.865	1.375	2.375
3-1/4	1	1	7/8 - 14	3/4 - 16	1 - 14	1.125	0.938	0.375	0.688	0.950	1.499	0.510	7/8	1-3/8	2.500	0.938	0.865	1.375	2.375
	3	1-3/8	1-1/4 - 12	1 - 14	1 - 3/8 - 14	1.625	1.063	0.375	0.875	1.320	1.999	0.635	1-1/8	1-7/8	3.250	1.313	0.990	1.625	2.750
4	1	1	7/8 - 14	3/4 - 16	1 - 14	1.125	0.938	0.375	0.688	0.950	1.499	0.510	7/8	1-3/8	2.500	0.938	0.865	1.375	2.375
	3	1-3/8	1-1/4 - 12	1 - 14	1 - 3/8 - 14	1.625	1.063	0.375	0.875	1.320	1.999	0.635	1-1/8	1-7/8	3.250	1.313	0.990	1.625	2.750
5	1	1	7/8 - 14	3/4 - 16	1 - 14	1.125	0.938	0.375	0.688	0.950	1.499	0.510	7/8	1-3/8	2.500	0.938	0.865	1.375	2.375
	3	1-3/8	1-1/4 - 12	1 - 14	1 - 3/8 - 14	1.625	1.063	0.375	0.875	1.320	1.999	0.635	1-1/8	1-7/8	3.250	1.313	0.990	1.625	2.750



For inventory, lead times, and kit lookup, visit [www.pdnplu.com](http://www.pdnplu.com)

## K-type Cylinder

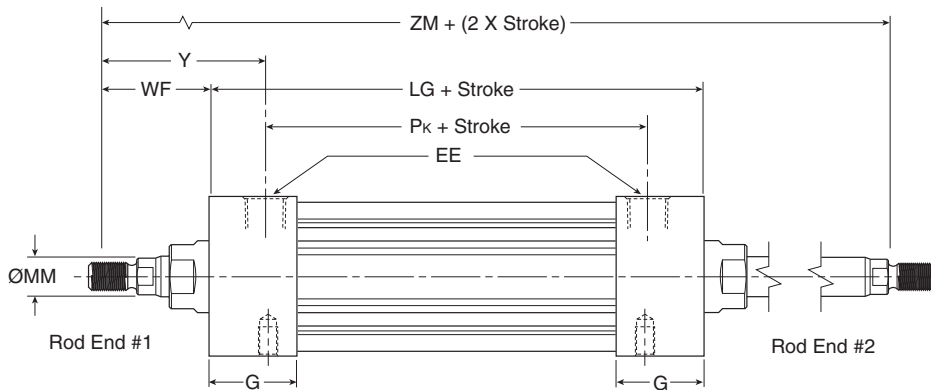
To determine dimensions for a double rod end cylinder, first refer to the desired single rod end mounting style cylinder shown in this catalog section. After selecting the necessary dimensions from that drawing, return to this page and supplement the single rod end dimensions with those shown in the drawings and dimension table below. Note that double rod end cylinders have a head dimension G at both ends, and

## Tie Rod Pneumatic Cylinders 4MA Series – 1-1/2" to 5" Bore Size

that LG replaces LF, P<sub>k</sub> replaces P, etc. The double rod end dimensions differ from, or are in addition to, those for single rod cylinders.

When a double rod end cylinder has two different rod ends, please clearly state which rod end is to be available at which head end.

### K-type for 1-1/2" to 5" Bore



Mounting styles for single rod models	Corresponding mounting styles for double rod models
C	KC
CB	KCB
D	KD
DD	KDD
F	KF
G	KG
J	KJ
NB	KNB
T	KT
TB	KTB
TD	KTD
TE	KTE
TEF	KTEF

### K-type Dimensions

Bore size	Rod no.	Rod dia. MM	Rod dia. EE (NPTF)	G	WF	Y	Add Stroke					Add 2X Stroke			
							LG	Pk	SAk	XAk	SSk	SNk	SEk	XEk	ZM
1-1/2	1	5/8	3/8	1.438	1.000	1.875	4.125	2.375	6.125	6.125	3.375	2.250	6.375	6.250	6.125
	2	1	3/8	1.438	1.375	2.250	4.125	2.375	6.500	6.500	3.375	-	-	-	5.760
2	1	5/8	3/8	1.375	1.000	1.875	4.125	2.375	6.125	6.125	3.375	2.250	6.750	6.438	6.125
	3	1	3/8	1.375	1.375	2.250	4.125	2.375	6.125	6.500	3.375	2.250	6.750	6.813	6.875
2-1/2	1	5/8	3/8	1.344	1.000	1.938	4.250	2.375	6.250	6.250	3.500	2.375	7.125	6.688	6.250
	3	1	3/8	1.344	1.375	2.313	4.250	2.375	6.250	6.625	3.500	2.375	7.125	7.063	7.000
3-1/4	1	1	1/2	1.594	1.375	2.438	4.750	2.625	7.250	7.375	3.750	2.625	7.750	7.625	7.500
	3	1-3/8	1/2	1.594	1.625	2.688	4.750	2.625	7.250	7.625	3.750	2.625	7.750	7.875	8.000
4	1	1	1/2	1.594	1.375	2.438	4.750	2.625	7.250	7.375	3.750	2.625	8.000	7.750	7.500
	3	1-3/8	1/2	1.594	1.625	2.688	4.750	2.625	7.250	7.625	3.750	2.625	8.000	8.000	8.000
5	1	1	1/2	1.594	1.375	2.438	4.938	2.813	7.688	7.688	3.563	2.813	-	-	7.688
	3	1-3/8	1/2	1.594	1.625	2.688	4.938	2.813	7.688	7.938	3.563	2.813	-	-	8.188
Replaces Dimension							LF	P	SA	XA	SS	SN	SE	XE	-
On Single Rod Mounting Styles							All Styles	All Styles	CB	CB	C	TEF, F	G	G	All

**B**

Tie Rod Pneumatic Cylinders

4MA Series

4MAJ Series

2MNR Series

ACVB Option

LPSO Option

P1D Series



For inventory, lead time, and kit lookup, visit [www.pdnplu.com](http://www.pdnplu.com)

B11

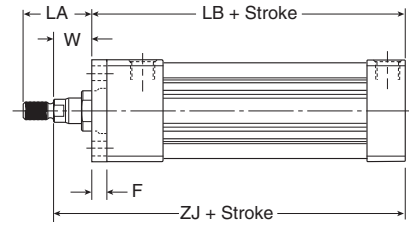
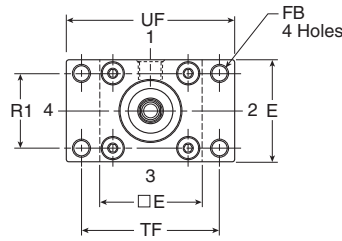
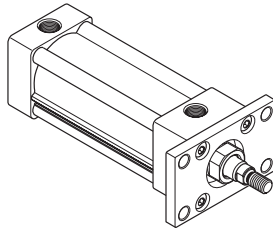
**Parker Hannifin Corporation**  
Pneumatic Division  
Richland, Michigan  
[www.parker.com/pneumatics](http://www.parker.com/pneumatics)

**Style J, H**

**Tie Rod Pneumatic Cylinders  
4MA/4ML Series – 1-1/2" to 5" Bore Size**

**Head Rectangular Flange**

Style J  
(NFPA MF1)

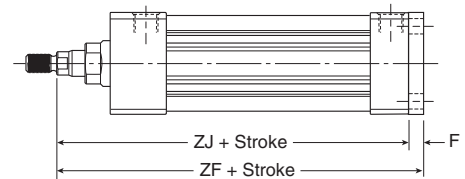
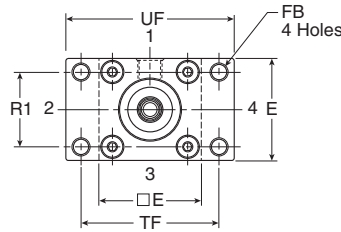
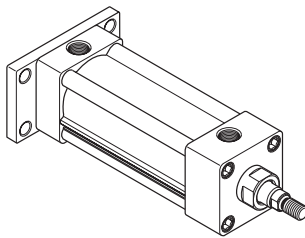


**Note:** Style J has a W dimension instead of WF and a LA dimension instead of LAF because of the flange installation. Please use dimensions W and LA regarding rod ends only for Style J.

For reference,  $WF = W + F$  and  $LA = W + A$ .

**Cap Rectangular Flange**

Style H  
(NFPA MF2)



**Styles J and H Dimensions**

Bore size	Rod no.	Rod dia. MM	A	E	F	FB	LA	R1	TF	UF	W	Add stroke		
												LB	ZF	ZJ
1-1/2	1	5/8	0.750	2.000	0.375	0.313	1.375	1.430	2.750	3.375	0.625	4.000	5.000	4.625
	2	1	1.125	2.000	0.375	0.313	2.125	1.430	2.750	3.375	1.000	4.000	5.375	5.000
2	1	5/8	0.750	2.500	0.375	0.375	1.375	1.840	3.375	4.125	0.625	4.000	5.000	4.625
	3	1	1.125	2.500	0.375	0.375	2.125	1.840	3.375	4.125	1.000	4.000	5.375	5.000
2-1/2	1	5/8	0.750	3.000	0.375	0.375	1.375	2.190	3.875	4.625	0.625	4.125	5.125	4.750
	3	1	1.125	3.000	0.375	0.375	2.125	2.190	3.875	4.625	1.000	4.125	5.500	5.125
3-1/4	1	1	1.125	3.750	0.625	0.438	1.875	2.760	4.688	5.500	0.750	4.875	6.250	5.625
	3	1-3/8	1.625	3.750	0.625	0.438	2.625	2.760	4.688	5.500	1.000	4.875	6.500	5.875
4	1	1	1.125	4.500	0.625	0.438	1.875	3.320	5.438	6.250	0.750	4.875	6.250	5.625
	3	1-3/8	1.625	4.500	0.625	0.438	2.625	3.320	5.438	6.250	1.000	4.875	6.500	5.875
5	1	1	1.125	5.500	0.625	0.563	1.875	4.100	6.625	7.625	0.750	5.125	6.500	5.875
	3	1-3/8	1.625	5.500	0.625	0.563	2.625	4.100	6.625	7.625	1.000	5.125	6.750	6.125

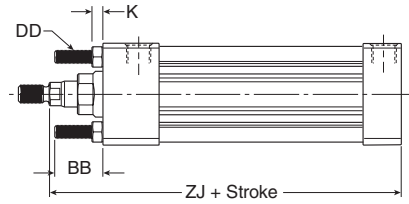
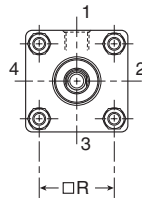
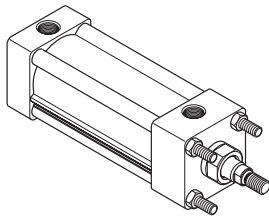


For inventory, lead times, and kit lookup, visit [www.pdnplu.com](http://www.pdnplu.com)



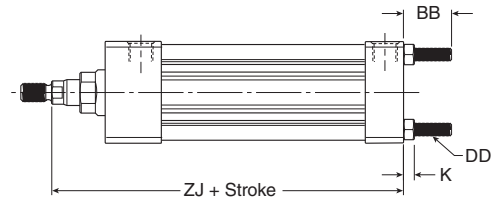
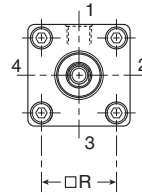
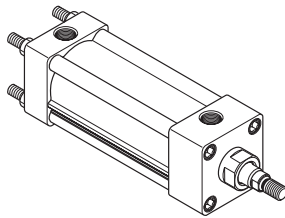
**Tie Rods Ext. Head End**

Style TB  
 (NFPA MX3)



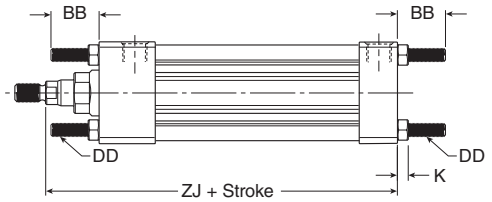
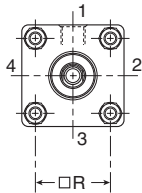
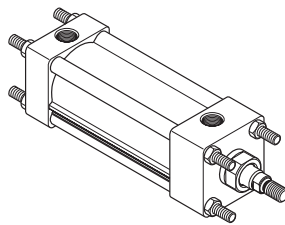
**Tie Rods Ext. Cap End**

Style TC  
 (NFPA MX2)



**Tie Rods Ext. Both Ends**

Style TD  
 (NFPA MX1)



**Styles TB, TC and TD Dimensions**

Bore size	Rod no.	Rod dia. MM	BB	DD	E	K	R	Add stroke	
								ZJ	
1-1/2	1	5/8	1.000	1/4 - 28	2.000	0.250	1.430	4.625	
	2	1	1.000	1/4 - 28	2.000	0.250	1.430	5.000	
2	1	5/8	1.125	5/16 - 24	2.500	0.313	1.840	4.625	
	3	1	1.125	5/16 - 24	2.500	0.313	1.840	5.000	
2-1/2	1	5/8	1.125	5/16 - 24	3.000	0.313	2.190	4.750	
	3	1	1.125	5/16 - 24	3.000	0.313	2.190	5.125	
3-1/4	1	1	1.375	3/8 - 24	3.750	0.375	2.760	5.625	
	3	1-3/8	1.375	3/8 - 24	3.750	0.375	2.760	5.875	
4	1	1	1.375	3/8 - 24	4.500	0.375	3.320	5.625	
	3	1-3/8	1.375	3/8 - 24	4.500	0.375	3.320	5.875	
5	1	1	1.813	1/2 - 20	5.500	0.438	4.100	5.875	
	3	1-3/8	1.813	1/2 - 20	5.500	0.438	4.100	6.125	

**B**

Tie Rod Pneumatic Cylinders

4MA Series

4MAJ Series

2MNR Series

ACVB Option

LPSO Option

P1D Series



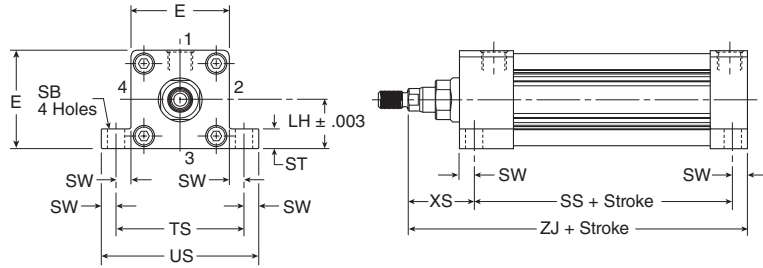
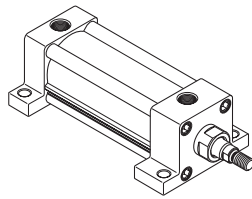
For inventory, lead time, and kit lookup, visit [www.pdnplu.com](http://www.pdnplu.com)

**Style C, CB**

**Tie Rod Pneumatic Cylinders  
4MA/4ML Series – 1-1/2" to 5" Bore Size**

**Side Lug**

Style C for  
(NFPA MS2)

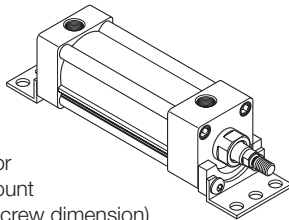


**Style C Dimensions**

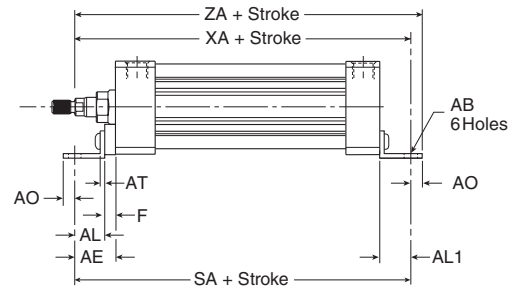
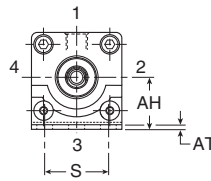
Bore size	Rod no.	Rod dia. MM	E	LH	SB	ST	ST1	ST2	SW	SW1	TS	US	Add stroke		
													SS	ZJ	
1-1/2	1	5/8	2.000	0.993	0.438	0.500	1.000	0.120	0.375	0.495	2.750	3.500	1.375	2.875	4.625
	2	1	2.000	0.993	0.438	0.500	1.000	0.120	0.375	0.495	2.750	3.500	1.750	2.875	5.000
2	1	5/8	2.500	1.243	0.438	0.500	1.250	0.120	0.375	0.495	3.250	4.000	1.375	2.875	4.625
	3	1	2.500	1.243	0.438	0.500	1.250	0.120	0.375	0.495	3.250	4.000	1.750	2.875	5.000
2-1/2	1	5/8	3.000	1.493	0.438	0.500	1.343	0.120	0.375	0.495	3.750	4.500	1.375	3.000	4.750
	3	1	3.000	1.493	0.438	0.500	1.343	0.120	0.375	0.495	3.750	4.500	1.750	3.000	5.125
3-1/4	1	1	3.750	1.868	0.563	0.750	1.500	0.188	0.500	0.688	4.750	5.750	1.875	3.250	5.625
	3	1-3/8	3.750	1.868	0.563	0.750	1.500	0.188	0.500	0.688	4.750	5.750	2.125	3.250	5.875
4	1	1	4.500	2.243	0.563	0.750	1.500	0.188	0.500	0.688	5.500	6.500	1.875	3.250	5.625
	3	1-3/8	4.500	2.243	0.563	0.750	1.500	0.188	0.500	0.688	5.500	6.500	2.125	3.250	5.875
5	1	1	5.500	2.743	0.813	1.000	1.500	0.250	0.688	0.938	6.875	8.250	2.063	3.125	5.875
	3	1-3/8	5.500	2.743	0.813	1.000	1.500	0.250	0.688	0.938	6.875	8.250	2.313	3.125	6.125

**Side End Angle**

\* Style CB  
(NFPA MS1)



**Note:**  
Dimension "S" is for the holes in the mount (not the screw to screw dimension)



\* Maximum recommended pressure for this mount is 150 PSIG.

**Style CB Dimensions**

Bore size	Rod no.	Rod dia. MM	AB	AE	AH	AL	AL1	AO	AT	E	F	S	Add stroke		
													SA	XA	ZA
1-1/2	1	5/8	0.438	1.375	1.188	1.000	1.000	0.375	0.125	2.000	0.375	1.250	6.000	5.625	6.000
	2	1	0.438	1.375	1.188	1.000	1.000	0.375	0.125	2.000	0.375	1.250	6.000	6.000	6.375
2	1	5/8	0.438	1.375	1.438	1.000	1.000	0.375	0.125	2.500	0.375	1.750	6.000	5.625	6.000
	3	1	0.438	1.375	1.438	1.000	1.000	0.375	0.125	2.500	0.375	1.750	6.000	6.000	6.375
2-1/2	1	5/8	0.438	1.375	1.625	1.000	1.000	0.375	0.125	3.000	0.375	2.250	6.125	5.750	6.125
	3	1	0.438	1.375	1.625	1.000	1.000	0.375	0.125	3.000	0.375	2.250	6.125	6.125	6.500
3-1/4	1	1	0.563	1.875	1.938	1.250	1.250	0.500	0.125	3.750	0.625	2.750	7.375	6.875	7.375
	3	1-3/8	0.563	1.875	1.938	1.250	1.250	0.500	0.125	3.750	0.625	2.750	7.375	7.125	7.625
4	1	1	0.563	-	2.250	1.875	1.250	0.500	0.125	4.500	-	3.500	7.375	6.875	7.375
	3	1-3/8	0.563	-	2.250	1.875	1.250	0.500	0.125	4.500	-	3.500	7.375	7.125	7.625
5	1	1	0.688	2.000	2.750	1.375	1.375	0.625	0.188	5.500	0.625	4.250	7.875	7.250	7.875
	3	1-3/8	0.688	2.000	2.750	1.375	1.375	0.625	0.188	5.500	0.625	4.250	7.875	7.500	8.125



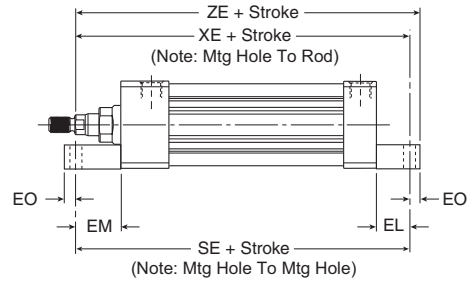
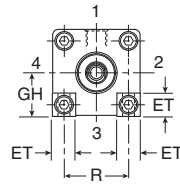
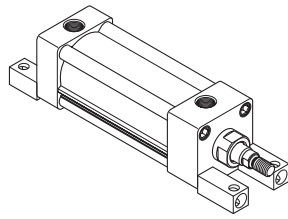
For inventory, lead times, and kit lookup, visit [www.pdnplu.com](http://www.pdnplu.com)

**Style G, NB**

**Tie Rod Pneumatic Cylinders  
4MA/4ML Series – 1-1/2" to 5" Bore Size**

**Side End Lug**

Style G  
(NFPA MS7)



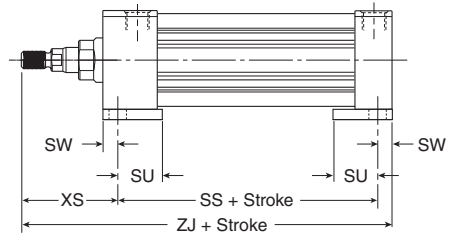
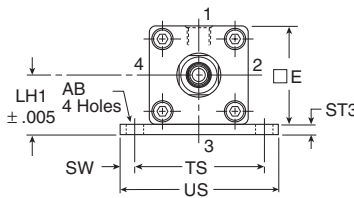
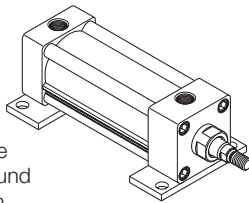
**Style G Dimensions**

Bore size	Rod no.	Rod dia. MM	E	EB	EL	EM	EO	ET	GH	R	Add Stroke		
											SE	XE	ZE
1-1/2	1	5/8	2.000	0.281	0.750	1.125	0.250	0.563	0.993	1.430	5.500	5.375	5.625
	2	1	-	-	-	-	-	-	-	-	-	-	-
2	1	5/8	2.500	0.344	0.938	1.313	0.313	0.688	1.243	1.840	5.875	5.563	5.875
	3	1	2.500	0.344	0.938	1.313	0.313	0.688	1.243	1.840	5.875	5.938	6.250
2-1/2	1	5/8	3.000	0.344	1.063	1.438	0.313	0.813	1.493	2.190	6.250	5.813	6.125
	3	1	3.000	0.344	1.063	1.438	0.313	0.813	1.493	2.190	6.250	6.188	6.500
3-1/4	1	1	3.750	0.406	0.875	1.500	0.375	1.000	1.868	2.760	6.625	6.500	6.875
	3	1-3/8	3.750	0.406	0.875	1.500	0.375	1.000	1.868	2.760	6.625	6.750	7.125
4	1	1	4.500	0.406	1.000	1.625	0.375	1.188	2.243	3.320	6.875	6.625	7.000
	3	1-3/8	4.500	0.406	1.000	1.625	0.375	1.188	2.243	3.320	6.875	6.875	7.250

**Base Bar Mount**

Style NB for 4MA

**Note:** Fasteners for NB base bar mount have been applied with removable thread locking compound and torqued to bottom of endcaps.



**Style NB Dimensions**

Bore size	Rod no.	Rod dia. MM	AB	E	LH1	ST3	SU	SW	TS	US	XS	Add stroke	
												SS	ZJ
1-1/2	1	5/8	0.438	2.000	1.243	0.250	1.125	0.375	2.750	3.500	1.375	2.875	4.625
	2	1	-	-	-	-	-	-	-	-	-	-	-
2	1	5/8	0.438	2.500	1.493	0.250	1.125	0.375	3.250	4.000	1.375	2.875	4.625
	3	1	0.438	2.500	1.493	0.250	1.125	0.375	3.250	4.000	1.750	2.875	5.000
2-1/2	1	5/8	0.438	3.000	1.868	0.375	1.125	0.375	3.750	4.500	1.375	3.000	4.750
	3	1	0.438	3.000	1.868	0.375	1.125	0.375	3.750	4.500	1.750	3.000	5.125
3-1/4	1	1	0.563	3.750	2.368	0.500	1.250	0.500	4.750	5.750	1.875	3.250	5.625
	3	1-3/8	0.563	3.750	2.368	0.500	1.250	0.500	4.750	5.750	2.125	3.250	5.875
4	1	1	0.563	4.500	2.743	0.500	1.250	0.500	5.500	6.500	1.875	3.250	5.625
	3	1-3/8	0.563	4.500	2.743	0.500	1.250	0.500	5.500	6.500	2.125	3.250	5.875

**B**

Tie Rod Pneumatic Cylinders

4MA Series

4MAJ Series

2MNR Series

ACVB Option

LPSO Option

P1D Series



For inventory, lead time, and kit lookup, visit [www.pdnplu.com](http://www.pdnplu.com)

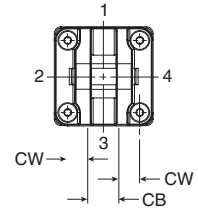
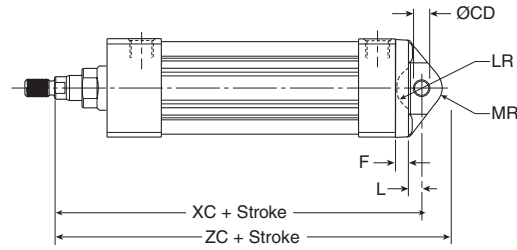
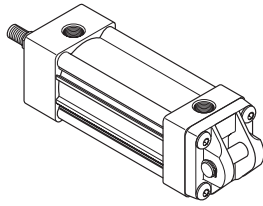
B15

**Parker Hannifin Corporation**  
Pneumatic Division  
Richland, Michigan  
[www.parker.com/pneumatics](http://www.parker.com/pneumatics)

**Cap Fixed Clevis**

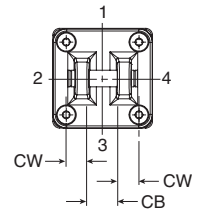
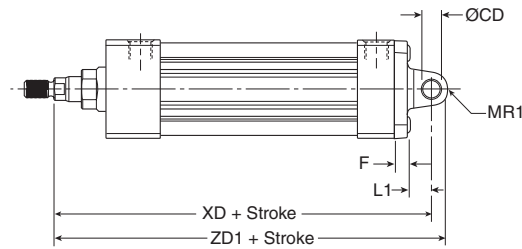
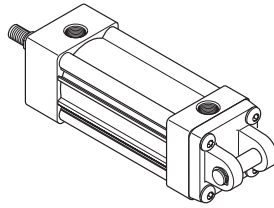
Style BB  
 (NFPA MP1)

**Note:** For maximum swivel angle of BB mount with rear mounting plate, see cylinder accessories



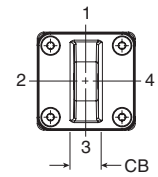
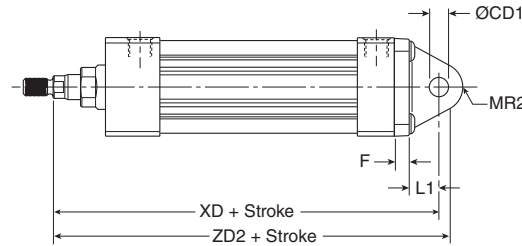
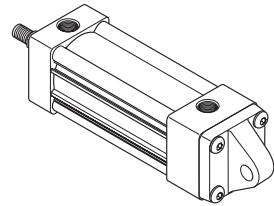
**Cap Detachable Clevis**

Style BC  
 (NFPA MP2)



**Cap Detachable Eye**

Style BE  
 (NFPA MP4)



**Styles BB, BC and BE Dimensions**

Bore size	Rod no.	Rod dia. MM	CB	+0.000 -0.002	+0.002 +0.004	CD	CD1	CW	E*	F	L	LR	L1	MR	MR1	MR2	Add stroke				
																	XC	XD	ZC	ZD1	ZD2
1-1/2	1	5/8	0.750	0.501	0.500	0.500	2.000	0.375	0.375	0.750	0.750	0.625	0.500	0.625	5.375	5.750	6.000	6.250	6.375		
	2	1	0.750	0.501	0.500	0.500	2.000	0.375	0.375	0.750	0.750	0.625	0.500	0.625	5.750	6.125	6.375	6.625	6.750		
2	1	5/8	0.750	0.501	0.500	0.500	2.500	0.375	0.375	0.750	0.750	0.625	0.500	0.625	5.375	5.750	6.000	6.250	6.375		
	3	1	0.750	0.501	0.500	0.500	2.500	0.375	0.375	0.750	0.750	0.625	0.500	0.625	5.750	6.125	6.375	6.625	6.750		
2-1/2	1	5/8	0.750	0.501	0.500	0.500	3.000	0.375	0.375	0.750	0.750	0.625	0.500	0.688	5.500	5.875	6.125	6.375	6.563		
	3	1	0.750	0.501	0.500	0.500	3.000	0.375	0.375	0.750	0.750	0.625	0.500	0.688	5.875	6.250	6.500	6.750	6.813		
3-1/4	1	1	1.250	0.751	0.750	0.625	3.750	0.625	0.625	1.000	1.250	0.938	0.750	0.875	6.875	7.500	7.813	8.250	8.375		
	3	1-3/8	1.250	0.751	0.750	0.625	3.750	0.625	0.625	1.000	1.250	0.938	0.750	0.875	7.125	7.750	8.063	8.500	8.625		
4	1	1	1.250	0.751	0.750	0.625	4.500	0.625	0.625	1.000	1.250	0.938	0.750	0.875	6.875	7.500	7.813	8.250	8.375		
	3	1-3/8	1.250	0.751	0.750	0.625	4.500	0.625	0.625	1.000	1.250	0.938	0.750	0.875	7.125	7.750	8.063	8.500	8.625		
5	1	1	1.250	0.751	0.750	0.625	5.500	0.625	0.625	1.000	1.250	0.938	0.750	0.875	7.125	7.750	8.063	8.500	8.625		
	3	1-3/8	1.250	0.751	0.750	0.625	5.500	0.625	0.625	1.000	1.250	0.938	0.750	0.875	7.375	8.000	8.313	8.750	8.875		

\* The 5" bore BB and BE bracket is the same as the 3-1/4" BB and BE bracket. The outer square dimension E is 3.75" and use SHCS.

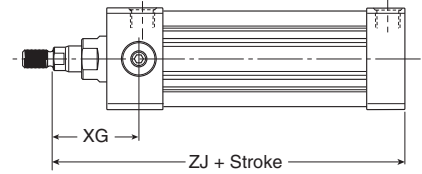
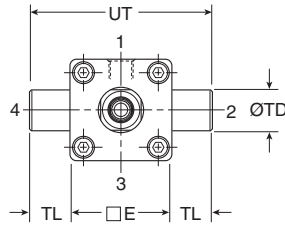
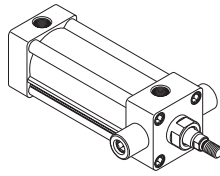


For inventory, lead times, and kit lookup, visit [www.pdnplu.com](http://www.pdnplu.com)

**Head Trunnion**

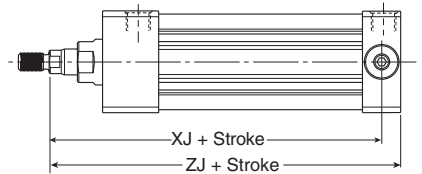
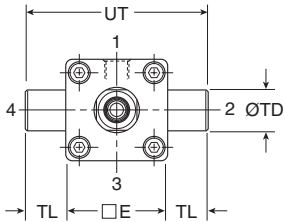
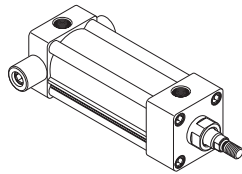
\* Style D  
 (NFPA MT1)

**Note:** not available for 1-1/2" bore with 1" rod.



**Cap Trunnion**

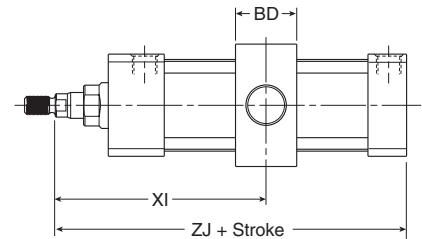
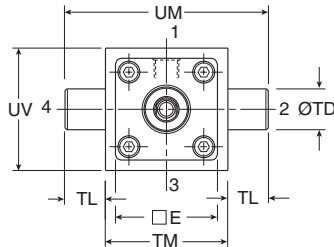
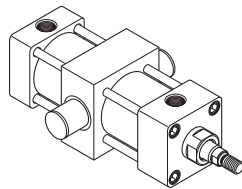
Style DB  
 (NFPA MT2)



**Intermediate Trunnion**

Style DD  
 (NFPA MT4)

**Note:** Tie rod nuts for Style DD have a slot instead of internal hex.



Note: Tie rod nuts for Style DD have a slot instead of internal hex.

**Styles D, DB and DD Dimensions**

Bore size	Rod no.	Rod dia. MM	E	BD	Rod dia. +.000 -0.001 TD	TL	TM	UM	UT	UV	XG	Min. XI	Add stroke	
													XJ	ZJ
1-1/2	1	5/8	2.000	1.250	1.000	1.000	2.500	4.500	4.000	2.500	1.750	3.036	4.125	4.625
	2*	1	2.000	1.250	1.000	1.000	2.500	4.500	4.000	2.500	-	3.437	4.250	5.000
2	1	5/8	2.500	1.500	1.000	1.000	3.000	5.000	4.500	3.000	1.750	3.125	4.125	4.625
	3	1	2.500	1.500	1.000	1.000	3.000	5.000	4.500	3.000	2.125	3.500	4.500	5.000
2-1/2	1	5/8	3.000	1.500	1.000	1.000	3.500	5.500	5.000	3.500	1.750	3.094	4.250	4.750
	3	1	3.000	1.500	1.000	1.000	3.500	5.500	5.000	3.500	2.125	3.469	4.625	5.125
3-1/4	1	1	3.750	2.000	1.000	1.000	4.500	6.500	5.750	4.250	2.250	3.969	5.000	5.625
	3	1-3/8	3.750	2.000	1.000	1.000	4.500	6.500	5.750	4.250	2.500	4.219	5.250	5.875
4	1	1	4.500	2.000	1.000	1.000	5.250	7.250	6.500	5.000	2.250	3.969	5.000	5.625
	3	1-3/8	4.500	2.000	1.000	1.000	5.250	7.250	6.500	5.000	2.500	4.219	5.250	5.875
5	1	1	5.500	2.000	1.000	1.000	6.250	8.250	7.500	6.000	2.250	3.969	5.250	5.875
	3	1-3/8	5.500	2.000	1.000	1.000	6.250	8.250	7.500	6.000	2.500	4.219	5.500	6.125

\* Head trunnion style D not available for 1-1/2" bore with 1" rod

**Kits & Accessories**

See page B34.



For inventory, lead time, and kit lookup, visit [www.pdnplu.com](http://www.pdnplu.com)

**Features**

**4MA/4ML Series – 6" and 8" Bore Size**

<b>B</b>	Tie Rod Pneumatic Cylinders
	4MA Series
	4MAJ Series
	2MNR Series
	ACVB Option
	LPSO Option
P1D Series	

**PISTON SEALS (hidden)**  
 Carboxylated nitrile rounded-lip piston seals combine low friction with leak-free service and long service life.

**PISTON ASSEMBLY (hidden)**  
 Aluminum piston with wear band increases service life and eliminates metal-to-metal contact. Optional magnetic piston ring for use with a variety of sensors. Anaerobic adhesive is used to permanently lock and seal the piston to the rod.

**HEADS AND CAPS**  
 High-strength aluminum heads and caps are anodized for corrosion resistance. We can offer customization of the endcaps for unique designs, including extra ports, duplex, tandem and many special mountings.

**PISTON ROD**  
 Standard case-hardened (50-64 Rc), hard chrome plated and polished carbon steel piston rod for reliable performance, long rod seal life and low friction. Grades of stainless steel are available as options.

**PORTS**  
 NPTF ports are standard. Other port styles available.

**ADJUSTABLE CUSHIONS available**

**CYLINDER BODY**  
 Hard anodized aluminum for corrosion resistance, maximum seal life and lower friction.

**TIE ROD CONSTRUCTION**  
 Steel tie rods and nuts for heavy-duty use. Stainless steel is available as an option.

**ROD GLAND/BEARING**  
 Threaded bronze rod gland is externally removable, without cylinder disassembly, for easy maintenance. Machined flats permit the use of common tools for removal and installation. Options include HI LOAD design for side load conditions and metallic wiper design for extremely tough rod contaminant/adherent applications.

**ROD SEAL (hidden)**  
 Carboxylated nitrile rounded-lip rod seal combines low friction with leak-free service and long service life.

**ROD WIPER**  
 Outboard urethane rod wiper protects the cylinder by removing external debris and adherents from the piston rod during the entire stroke.

For a complete list of 4MA options, please see pages B19 and B23.

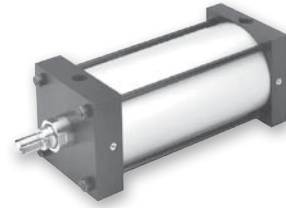


For inventory, lead times, and kit lookup, visit [www.pdnplu.com](http://www.pdnplu.com)

# Tie Rod Pneumatic Cylinders 4MA/4ML Series – 6" and 8" Bore Size

## Features

- Industry leading NFPA interchangeable cylinder with flexible construction
- Bore sizes – 6" and 8"
- Removable bronze alloy gland/bearing for easy maintenance
- Available in any practical stroke length
- Tube and tie rod construction for heavy duty use
- Single rod end or double rod ends
- Cushions – optional and adjustable at either end or both ends (N/A for 4ML hydraulic version)
- 20 standard mounting styles available
- RoHS compliant



## Operating information

	4MA	4ML
Operating pressure:	250 PSIG (17 bar) maximum air service	400 PSIG (27 bar) maximum hydraulic service
Temperature range –		
Standard seals	-10°F to 165°F (-23°C to 74°C)	
Fluorocarbon seals	-10°F to 250°F (-23°C to 121°C)	
Low temperature seals	-50°F to 150°F (-46°C to 66°C)	
Filtration requirements:	40 micron, dry filtered air    Filtered hydraulic oil	

## Ordering information

<b>6.00</b>		<b>J</b>	<b>4MA</b>		<b>U</b>		<b>1</b>	<b>4</b>		<b>A</b>		<b>12.000</b>
<b>Bore size</b>		<b>Double rod cylinder</b>	<b>Series</b>		<b>Ports</b>		<b>Piston rod number</b>			<b>Cushion cap end</b>		<b>Stroke length</b>
6.00 8.00		Specify "K" only if double rod cylinder is required.	4MA Air service 4ML Hydraulic service		U NPTF R BSPP B BSPT T SAE		Specify rod code number for required diameter. <sup>8,2</sup>			Blank Non-cushioned cap end C Cushioned cap end (not available for 4ML)		Specify stroke length required in inches. <sup>8</sup>
		<b>Mounting style</b>					<b>Special modification</b>			<b>Piston rod thread type</b>		
		Specify mounting style code (see table on following page).					Specify "S" only for special modification other than rod end, and then describe modification in item notes. (Includes 4MA with Linear Position Sensor Option) <sup>7</sup>			A Standard (UNF unified thread) W BSF British fine M* Metric		
		<b>Cushion head end</b>								* Please reference page B78.		
		Blank Non-cushioned head end C Cushioned head end (not available for 4ML)								<b>Seals</b>		
										Blank Standard (nitrile seals) V Fluorocarbon seals <sup>1</sup> E Fluorocarbon rod wiper and rod seal only <sup>2</sup> 4 Low temperature seals <sup>1</sup> M Metallic rod wiper, nitrile seals <sup>3</sup>		
		<b>Piston type</b>								<b>Piston rod thread style</b>		
		Blank Standard (lipseals and magnetic ring) 3 Lipseals and magnetic ring								4 Small male 8 Intermediate male 9 Short female 55 For use with split coupler <sup>6</sup> 3 Special (and specify all dimensions required) 6 Full male		
										<b>Rod material and gland code</b>		
										Blank Standard rod and gland H Standard rod and HI LOAD gland Y 17-4 PH stainless steel rod and standard gland Z 17-4 PH stainless steel rod and HI LOAD gland J 303 stainless steel rod and standard gland <sup>7</sup> K 303 stainless steel rod and HI LOAD gland <sup>7</sup> S 316 stainless steel rod and standard gland <sup>7</sup> T 316 stainless steel rod and HI LOAD gland <sup>7</sup>		
										<b>Sensors</b> See section L for sensors.		

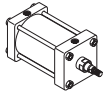
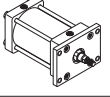
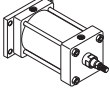
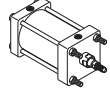
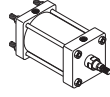
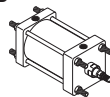
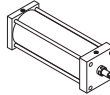
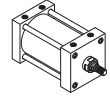
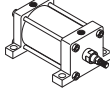
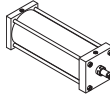
<sup>1</sup> Reed and solid-state sensors only available with standard seals or options E and M.  
<sup>2</sup> Used for external chemical compatibility applications, not high temperature.  
<sup>3</sup> If fluorocarbon seals are required with this option, please place an "S" for special in the Special Modification field and specify the "fluorocarbon seals and metallic rod wiper" in the item notes.  
<sup>4</sup> For Linear Position Sensor Option (LPSO), please include the following information for the Special Modification item notes:  
 a. Sensor part number (please reference pages B72-B76)  
 b. Sensor position  
 c. Port position (if other than position 1)  
 d. Length of stop tubing, gross stroke and net stroke (if required)  
 Also, Piston Type 3 is required.  
<sup>5</sup> Review Piston Rod Selection Chart, please reference page A14 to determine proper piston rod diameter.  
<sup>6</sup> For additional information regarding this style, please reference page B77. If non-standard Rod Material and Gland Code is required with this option, please place an "S" for special in Special Modification field and specify Rod Material and Gland Code in the item notes.  
<sup>7</sup> Not available for 4ML.  
<sup>8</sup> If a stop tube is required, specify gross stroke (net stroke + stop tube) in the model number, then place an "S" for special in the Special Modification field and specify the stop tube length in the item notes.

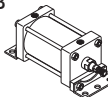
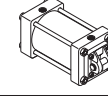
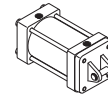
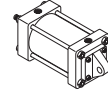
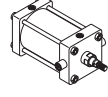
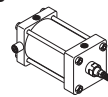
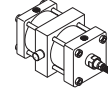
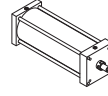
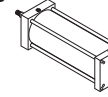
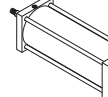
For ordering purposes, when special options or common modifications are requested, the factory will assign a sequential part number in place of the model number.



For inventory, lead time, and kit lookup, visit [www.pdnplu.com](http://www.pdnplu.com)

**4MA/4ML Mounting Styles for 6" & 8" Bore**

Mounting style	NFPA mounting	Description	Bore size
T 	MX0	No Mount	6 - 8
J 	MF1	Head Rectangular Flange	6
H 	MF2	Cap Rectangular Flange	6
TB 	MX3	Tie Rods Extended Head End	6 - 8
TC 	MX2	Tie Rods Extended Cap End	6 - 8
TD 	MX1	Tie Rods Extended Both Ends	6 - 8
TE 	MX5	Sleeve Nut	6 - 8
TEF 	MX5/MS4	Sleeve Nut with Side Tap	6 - 8
C 	MS2	Side Lug	6 - 8
F 	MS4	Side Tap	6 - 8

Mounting style	NFPA mounting	Description	Bore size
CB 	MS1	Side End Angle	6 - 8
BB 	MP1	Cap Fixed Clevis	6 - 8
BC 	MP2	Cap Detachable Clevis	6 - 8
BE 	MP4	Cap Detachable Eye	6
D 	MT1	Head Trunnion	6 - 8
DB 	MT2	Cap Trunnion	6 - 8
DD 	MT4	Intermediate Trunnion	6 - 8
JB 	ME3	Head Square	8
HB 	ME4	Cap Square	8
KT † 	MDX0	Double Rod End, No Mount	6 - 8

† Double rod end cylinders can be ordered with head mountings, i.e. KJ.

**B**  
 Tie Rod Pneumatic Cylinders  
 4MA Series  
 4MAJ Series  
 2MNR Series  
 ACVB Option  
 LPS0 Option  
 P1D Series



For inventory, lead times, and kit lookup, visit [www.pdnplu.com](http://www.pdnplu.com)



## Specifications

## Tie Rod Pneumatic Cylinders 4MA/4ML Series – 6” and 8” Bore Size

### General Specifications

- NFPA interchangeable
  - Bore sizes – 6" and 8"
  - Strokes – available in any practical stroke length
  - Rod diameters – 1-3/8" and 1-3/4"
  - Rod end styles – 4 standard, specials available
  - Single rod end or double rod ends
  - Cushions – optional and adjustable at either end or both ends (N/A for 4ML Hydraulic Version)
  - Operating pressure –  
4MA = 250 PSIG (17 Bar) maximum air service  
4ML = 400 PSIG (27 Bar) maximum hydraulic service
  - Media – 4MA = dry, filtered air  
4ML = filtered hydraulic oil
  - Temperature range –  
-10°F to 165°F (-23°C to 74°C) standard seals  
-10°F to 250°F (-23°C to 121°C) fluorocarbon seals option  
-50°F to 150°F (-46°C to 66°C) low temperature seals option
  - Mounting styles – 20 standard styles
  - RoHS compliant
- For material options, including seals, piston rods and glands, please see Material Specifications on next page.

### Cylinder Weights

Bore (inch)	Rod (inch)	No mount single rod 4MA/4ML		No mount double rod	
		Base wt. (lbs.)	Per inch (lbs.)	Base wt. (lbs.)	Per inch (lbs.)
6	1.375	20.50	0.87	25.65	1.30
	1.75	22.61	1.13	30.41	1.82
8	1.375	35.50	1.25	41.15	1.68
	1.75	37.63	1.51	45.90	2.20

### Mounting Weight Adders

Bore (inch)	Mounting style, weight (lbs)							
	J, H	D, DB	BB	CB	DD	BE	C	BC
6	10.74	1.22	2.91	5.88	15.52	2.91	0.69	11.38
8	N/A	1.22	2.91	7.84	25.01	N/A	0.67	17.31

### Standard Cushion Position

Mounting Code	Position
All except D, DB, DD	2
D, DB, DD	3

### Standard Port Sizes

Bore	NPTF	BSPT	BSPP	SAE
6	3/4	Rc3/4	G3/4	12
8	3/4	Rc3/4	G3/4	12

**B**

Tie Rod Pneumatic Cylinders

4MA Series

4MAJ Series

2MNR Series

ACVB Option

LPSO Option

P1D Series



For inventory, lead time, and kit lookup, visit [www.pdnplu.com](http://www.pdnplu.com)

B21

**Parker Hannifin Corporation**  
Pneumatic Division  
Richland, Michigan  
[www.parker.com/pneumatics](http://www.parker.com/pneumatics)

## Material Specifications

### Standard Temperatures and Applications

Head and cap	Black anodized aluminum alloy
Cylinder body	Clear hard-coat anodized aluminum alloy
Piston rod	Case-hardened, chrome plated carbon steel
Rod seal	Carboxylated nitrile (Nitroxile)
Rod wiper	Molythane
Rod bearing (gland)	Bronze alloy
Piston	Aluminum alloy
Piston seals	Carboxylated nitrile (Nitroxile)
Piston bearing	MolyGard™
Magnetic ring	Plastic-bound magnetic material
Piston fastener	Piston rod for aluminum piston
O-rings	Nitrile
End seals	Nitrile
Cushion seals	Urethane
Cushion needle valves	Brass cushion needle valves
Tie-rods	Blackened carbon steel
Tie-rod nuts	Steel alloy, SAE J995 Grade 8

## Tie Rod Pneumatic Cylinders

### 4MA/4ML Series – 6” and 8” Bore Size

### Material and Part Changes

#### 4MA Options

High temperatures (-10°F to 250°F)	All seals and wiper are fluorocarbon Aluminum piston without magnetic ring
Low temperatures (-50°F to 150°F)	Rod seal, piston seals, o-rings and end seals are low temperature-rated nitrile

#### 4ML Hydraulic Version

Hydraulic service (general)	Cushions not available
Hydraulic service (std temp)	Polyurethane TS-2000 rod seal and nitrile piston seals (for hydraulic use)
Hydraulic service (high temp)	Fluorocarbon TS-2000 rod seal; wiper and all seals are fluorocarbon (for hydraulic use)

#### Other Standard Options

Cylinder seal options	Fluorocarbon for high temperatures or chemical compatibility Other seal options available, please consult factory
Piston rod material options	Case-hardened, chrome plated carbon steel (standard) 17-4 PH stainless steel, chrome plated 303 stainless steel, chrome plated (N/A for 4ML) 316 stainless steel, chrome plated (N/A for 4ML) For stainless steel without chrome plating, please consult factory
HI LOAD gland option	Composite bearing pressed into bronze alloy gland
Metallic rod scraper option	Dual high strength bronze wipers with fluorocarbon energizer

<b>B</b>	Tie Rod Pneumatic Cylinders		
			4MA Series
			4MAJ Series
			2MNR Series
			ACVB Option
			LPSO Option
			P1D Series



For inventory, lead times, and kit lookup, visit [www.pdnplu.com](http://www.pdnplu.com)

**How to Select a 6” - 8” Bore 4MA Cylinder**

Parker cylinders are available based on air or hydraulic operating pressure. The many styles, sizes and optional features available assure that your application requirements are precisely met. To select a cylinder, follow these simple steps:

- Step 1 - **Determine the correct cylinder bore size** necessary to achieve required force using the available operating pressure.
- Step 2 - **Determine the series cylinder to use**, based on operating pressure.
- Step 3 - **Turn to the appropriate cylinder selection section.** Select the mounting style that fits your installation needs. Determine the bore and rod sizes available for the model you select. Then complete model selection.
  - Choose a rod end style and the desired rod end accessories.
  - Size the cylinder to meet your application requirements.
- Step 4 - **Consider the following conditions** which may require further modifications to the cylinder you have selected.

Application Condition	Check the Following
Quick Starts or Stops	Confirm that determined thrust is sufficient to accelerate or decelerate cylinder and load within prescribed distance. Optional cushions should be used to reduce shock during deceleration, check that peak pressures will be within tolerable limits.
Long Push Stroke	Check whether stop tube is required to prevent excessive bearing loads and wear.
High-column Loading Long Push Stroke	Determine if standard size piston rod is strong enough to accommodate intended load. See Application Engineering section for recommendations.
Long Horizontal Stroke	Determine if standard size piston rod is strong enough to accommodate intended load.
High Operating Temperatures	For temperatures between 165°F and 250°F use 4MA cylinder with high temperature seals.

**General Options and Modifications:**

- Adjustable Cushions
- Magnetic Piston
- Port and Adjustable Cushion Relocation
- Port Thread Styles
- Multiple Ports
- Special Heads, Caps, Pistons and Mounts
- Double Rod End
- Oversize Rod Diameters
- Rod End Modifications
- Rod Materials (grades of stainless steel)
- Stainless Steel Tie Rods and Nuts
- Fluorocarbon Rod Wiper and Rod Seal only
- Fluorocarbon Seals (all cylinder seals)
- Metallic Rod Wiper
- HI LOAD Gland Assembly
- Stop Tube
- Mixed Mountings
- Shock Absorber on Cap End
- Air Cylinder/Valve Combination (ACVB)
- Adjustable Point Sensors (order separately)
- Continuous Linear Position Sensing (LPSO)
- High Temperature Service (to 250°F)
- Low Temperature Service (to -50°F)
- Hydraulic Service (4ML) (400 PSIG)
- Rod lock version (see 4MAJ)

B
Tie Rod Pneumatic Cylinders
4MA Series
4MAJ Series
2MNR Series
ACVB Option
LPSO Option
P1D Series

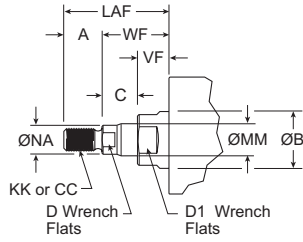
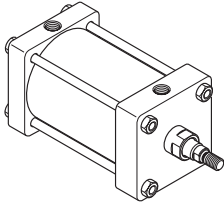


For inventory, lead time, and kit lookup, visit [www.pdnplu.com](http://www.pdnplu.com)

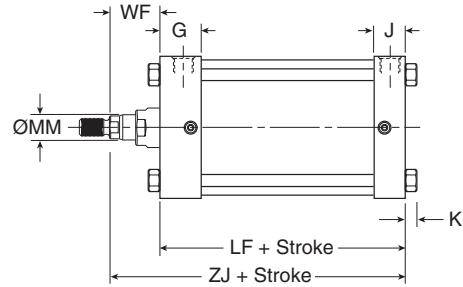
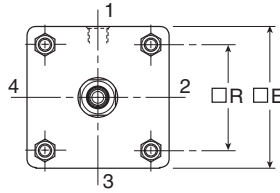
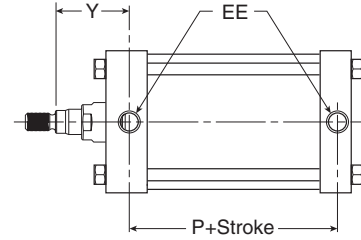
**Style T**

**Tie Rod Pneumatic Cylinders  
4MA/4ML Series – 6” and 8” Bore Size**

**Single Rod  
(Style T)**



For dimensions of all standard rod end styles, please see next page.



**Style T Dimensions**

Bore size	Rod no.	Rod dia. MM	Thread			Style 6	A	AA	B	C	D	D1	E	EE (NPTF)	G
			Style 8 CC	Style 4 & 9 KK	Style 9										
6	1	1-3/8	1-1/4 - 12	1-14	1-3/8 - 14	1.625	6.900	1.999	0.635	1-1/8	1-7/8	6.500	3/4	1.910	
	3	1-3/4	1-1/2 - 12	1-1/4 - 12	1-3/4 - 12	2.000	6.900	2.374	0.760	1-1/2	2-3/16	6.500	3/4	1.910	
8	1	1-3/8	1-1/4 - 12	1-14	1-3/8 - 14	1.625	9.100	1.999	0.635	1-1/8	1-7/8	8.500	3/4	1.810	
	3	1-3/4	1-1/2 - 12	1-1/4 - 12	1-3/4 - 12	2.000	9.100	2.374	0.760	1-1/2	2-3/16	8.500	3/4	1.810	

Bore size	Rod no.	Rod dia. MM	J	K	LAF	NA	R	VF	WF	Y	Add stroke		
											LF	P	ZJ
6	1	1-3/8	1.410	0.438	3.250	1.313	4.880	0.990	1.625	2.813	5.000	3.125	6.625
	3	1-3/4	1.410	0.438	3.875	1.688	4.880	1.115	1.875	3.063	5.000	3.125	6.875
8	1	1-3/8	1.440	0.563	3.250	1.313	6.440	0.990	1.625	2.750	5.125	3.250	6.750
	3	1-3/4	1.440	0.563	3.875	1.688	6.440	1.115	1.875	3.000	5.125	3.250	7.000



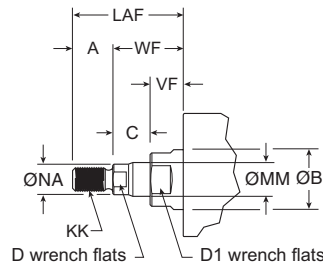
For inventory, lead times, and kit lookup, visit [www.pdnplu.com](http://www.pdnplu.com)

# Rod End Thread Styles

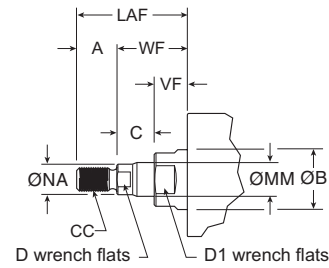
# Tie Rod Pneumatic Cylinders 4MA/4ML Series – 6” and 8” Bore Size

## Rod End

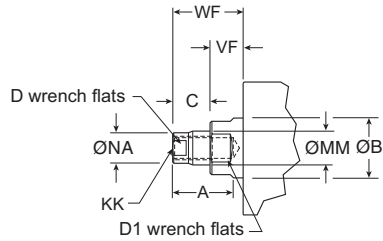
**Thread Style 4**  
(NFPA Style SM)  
Small Male



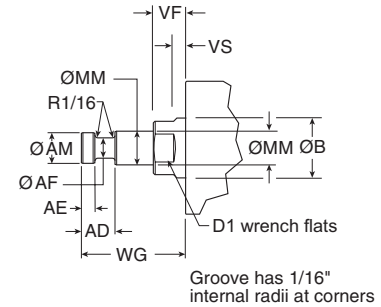
**Thread Style 8**  
(NFPA Style IM)  
Intermediate Male



**Thread Style 9**  
(NFPA Style SF)  
Short Female



**Thread Style 55**  
For use with Split Coupler  
(please reference page B77 for more information)



### Thread Style 3 - "Special Thread"

Special threads, rod extensions, rod eyes, blanks, etc. are also available. To order, specify "Style 3" and give desired dimensions for KK or CC, A and W or WF. If otherwise special, please supply dimensioned sketch.

## Rod End Dimensions

Bore size	Rod no.	Rod dia. MM	Thread		Style 6	A	AD	AE	AF	AM	B	C	D	D1	LAF	NA	VF	WF	WG
			Style 8 CC	Style 4 & 9 KK															
6	1	1-3/8	1-1/4 - 12	1 - 14	1-3/8 - 14	1.625	1.063	0.375	0.875	1.320	1.999	0.635	1-1/8	1-7/8	3.250	1.313	0.990	1.625	2.750
	3	1-3/4	1-1/2 - 12	1-1/4 - 12	1-3/4 - 12	2.000	1.313	0.500	1.125	1.700	2.374	0.760	1-1/2	2-3/16	3.875	1.688	1.115	1.875	3.125
8	1	1-3/8	1-1/4 - 12	1 - 14	1-3/8 - 14	1.625	1.063	0.375	0.875	1.320	1.999	0.635	1-1/8	1-7/8	3.250	1.313	0.990	1.625	2.750
	3	1-3/4	1-1/2 - 12	1-1/4 - 12	1-3/4 - 12	2.000	1.313	0.500	1.125	1.700	2.374	0.760	1-1/2	2-3/16	3.875	1.688	1.115	1.875	3.125

**B**

Tie Rod Pneumatic Cylinders

4MA Series

4MAJ Series

2MNR Series

ACVB Option

LPSO Option

P1D Series



For inventory, lead time, and kit lookup, visit [www.pdnplu.com](http://www.pdnplu.com)

B25

**Parker Hannifin Corporation**  
Pneumatic Division  
Richland, Michigan  
[www.parker.com/pneumatics](http://www.parker.com/pneumatics)

## K-type Cylinder

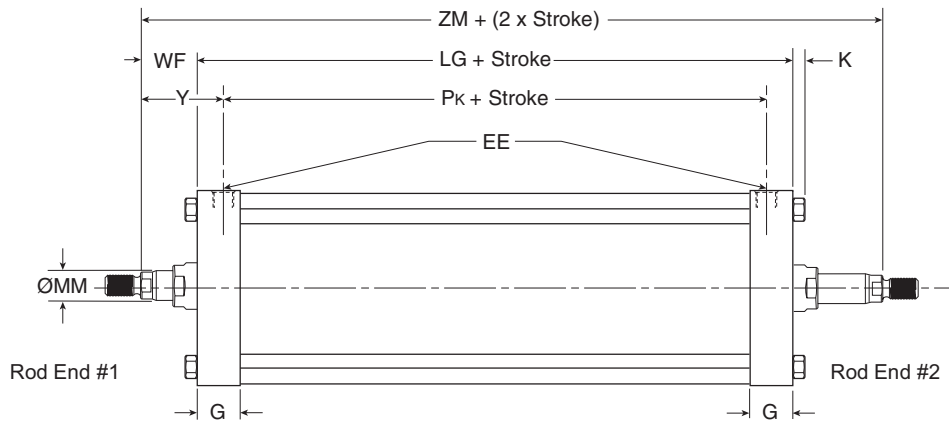
To determine dimensions for a double rod end cylinder, first refer to the desired single rod end mounting style cylinder shown in this catalog section. After selecting the necessary dimensions from that drawing, return to this page and supplement the single rod end dimensions with those shown in the drawings and dimension table below. Note that double rod end cylinders have a head dimension G at both ends, and

## Tie Rod Pneumatic Cylinders 4MA/4ML Series – 6” and 8” Bore Size

that LG replaces LF, PK replaces P, etc. The double rod end dimensions differ from, or are in addition to, those for single rod cylinders.

When a double rod end cylinder has two different rod ends, please clearly state which rod end is to be available at which head end.

### K-type for 6” & 8” bore



Mounting styles for single rod models	Corresponding mounting styles for double rod models
C	KC
CB	KCB
D	KD
DD	KDD
F	KF
J	KJ
T	KT
TB	KTB
TD	KTD
TE	KTE
TEF	KTEF

### Style KT Dimensions

Bore size	Rod no.	Rod dia. MM	EE (NPTF)	G	K	WF	Y	Add stroke			Add 2X stroke			
								LG	Pk	SAk	XAk	SSk	SNk	ZM
6	1	1-3/8	3/4	1.910	0.438	1.625	2.813	5.500	3.125	8.250	8.500	4.125	3.125	8.750
	3	1-3/4	3/4	1.910	0.438	1.875	3.063	5.500	3.125	8.250	8.750	4.125	3.125	9.250
8	1	1-3/8	3/4	1.810	0.563	1.625	2.750	5.500	3.250	9.125	8.938	4.125	3.125	8.750
	3	1-3/4	3/4	1.810	0.563	1.875	3.000	5.500	3.250	9.125	9.188	4.125	3.125	9.250
Replaces Dimension								LF	P	SA	XA	SS	SN	-
On Single Rod Mounting Styles								All Styles	All Styles	CB	CB	C	F, TEF	All

**B**  
 Tie Rod Pneumatic Cylinders  
 4MA Series  
 4MAJ Series  
 2MNR Series  
 ACVB Option  
 LPSO Option  
 P1D Series



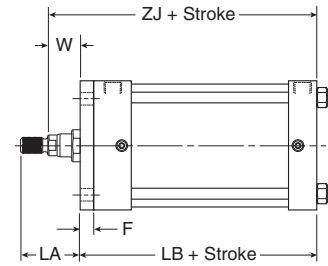
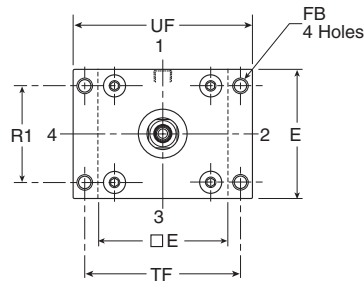
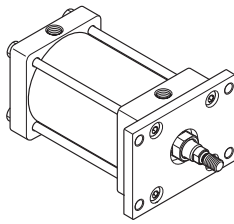
For inventory, lead times, and kit lookup, visit [www.pdnplu.com](http://www.pdnplu.com)

# Style J, H

# Tie Rod Pneumatic Cylinders 4MA/4ML Series – 6" and 8" Bore Size

## Head Rectangular Flange

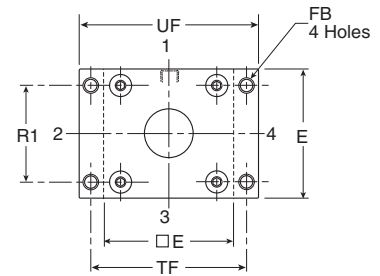
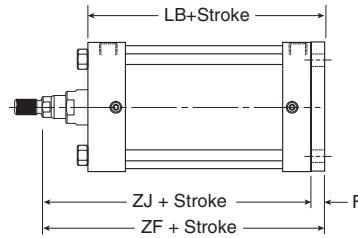
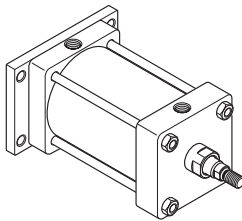
Style J  
(NFFA MF1)  
(only 6" Bore)



**Note:** Style J has a W dimension instead of WF and a LA dimension instead of LAF because of the flange installation. Please use dimensions W and LA regarding rod ends only for Style J. For reference,  $WF = W + F$  and  $LA = W + A$ .

## Cap Rectangular Flange

Style H  
(NFFA MF2)  
(only 6" Bore)



## Styles J and H Dimensions

Bore size	Rod no.	Rod dia. MM	A	E	F	FB	LA	R1	TF	UF	W	Add stroke		
												LB	ZF	ZJ
6	1	1-3/8	1.625	6.500	0.750	0.563	2.500	4.880	7.625	8.625	0.875	5.750	7.375	6.625
	3	1-3/4	2.000	6.500	0.750	0.563	3.125	4.880	7.625	8.625	1.125	5.750	7.625	6.875

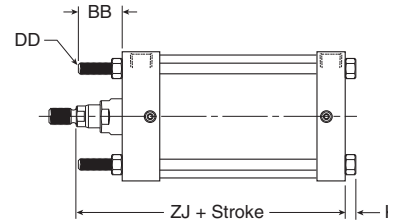
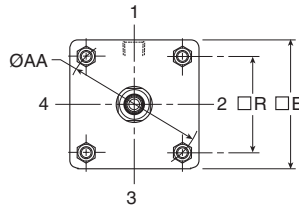
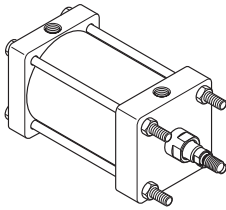
B
Tie Rod Pneumatic Cylinders
4MA Series
4MAJ Series
2MNR Series
ACVB Option
LPSO Option
P1D Series



For inventory, lead time, and kit lookup, visit [www.pdnplu.com](http://www.pdnplu.com)

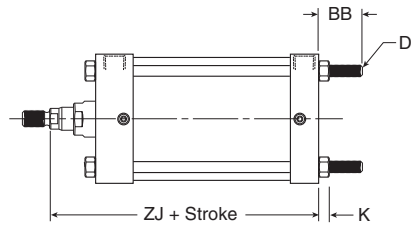
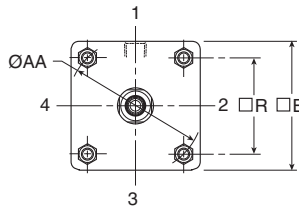
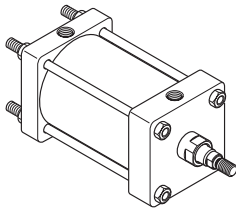
**Tie Rods Ext. Head End**

Style TB  
 (NFPA MX3)



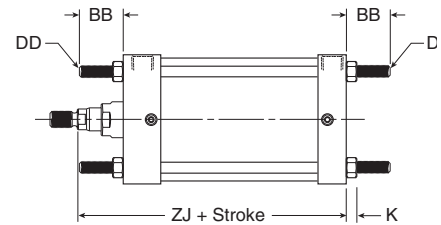
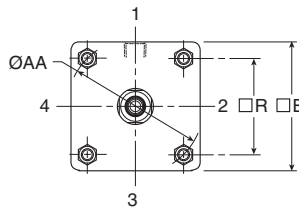
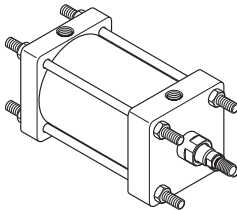
**Tie Rods Ext. Cap End**

Style TC  
 (NFPA MX2)



**Tie Rods Ext. Both Ends**

Style TD  
 (NFPA MX1)



**Styles TB, TC and TD Dimensions**

Bore size	Rod no.	Rod dia. MM	AA	BB	DD	E	K	R	Add stroke
									ZJ
6	1	1-3/8	6.900	1.813	1/2-20	6.500	0.438	4.880	6.625
	3	1-3/4	6.900	1.813	1/2-20	6.500	0.438	4.880	6.875
8	1	1-3/8	9.100	2.313	5/8-18	8.500	0.563	6.440	6.750
	3	1-3/4	9.100	2.313	5/8-18	8.500	0.563	6.440	7.000

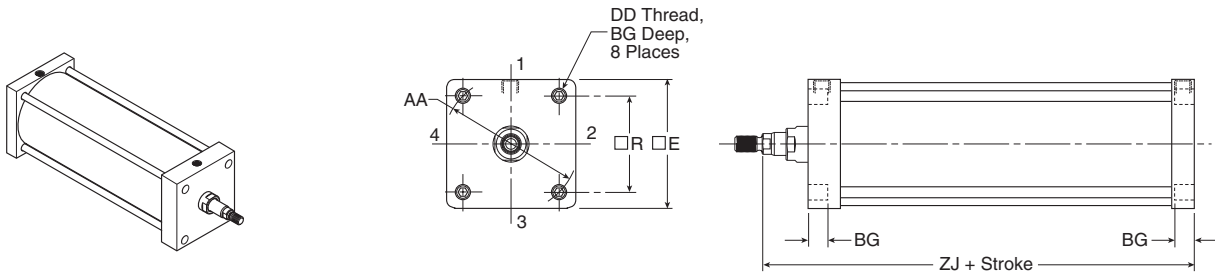
**B**  
 Tie Rod Pneumatic Cylinders  
 4MA Series  
 4MAJ Series  
 2MNR Series  
 ACVB Option  
 LPSO Option  
 P1D Series



For inventory, lead times, and kit lookup, visit [www.pdnplu.com](http://www.pdnplu.com)



**Sleeve Nut**  
 Style TE  
 (NFPA MX5)

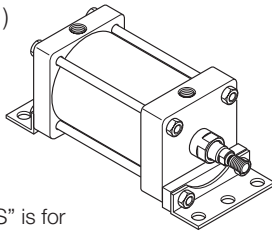


**Style TE Dimensions**

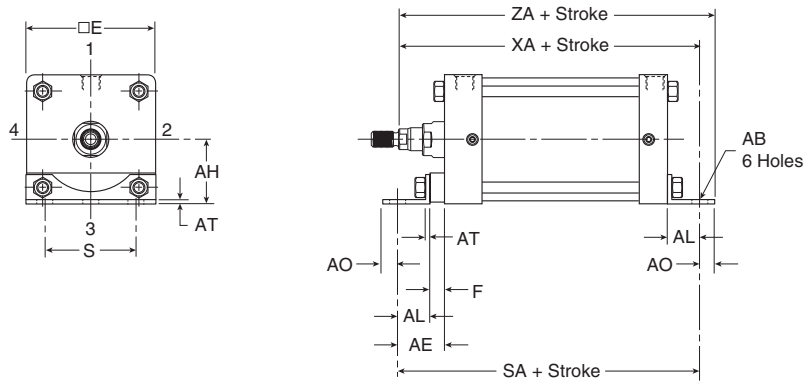
Bore size	Rod no.	Rod dia. MM	AA	BG	DD	E	R	Add stroke
								ZJ
6	1	1-3/8	6.900	0.500	1/2-20	6.500	4.880	6.625
	3	1-3/4	6.900	0.500	1/2-20	6.500	4.880	6.875
8	1	1-3/8	9.100	0.620	5/8-18	8.500	6.440	6.750
	3	1-3/4	9.100	0.620	5/8-18	8.500	6.440	7.000

**Side End Angle**

\* Style CB  
 (NFPA MS1)



**Note:**  
 Dimension "S" is for the holes in the mount (not the screw to screw dimension)



\*Maximum recommended pressure for this mount is 150 PSIG

**Style CB Dimensions**

Bore size	Rod no.	Rod dia. MM	AB	AE	AH	AL	AO	AT	E	F	S	Add stroke		
												SA	XA	ZA
6	1	1-3/8	0.813	2.125	3.250	1.375	0.625	0.188	6.500	0.750	5.250	8.500	8.000	8.625
	3	1-3/4	0.813	2.125	3.250	1.375	0.625	0.188	6.500	0.750	5.250	8.500	8.250	8.875
8	1	1-3/8	0.813	1.813	4.250	1.813	0.688	0.250	8.500	-	7.125	8.750	8.563	9.250
	3	1-3/4	0.813	1.813	4.250	1.813	0.688	0.250	8.500	-	7.125	8.750	8.813	9.500

**B**

Tie Rod Pneumatic Cylinders

4MA Series

4MAJ Series

2MNR Series

ACVB Option

LPSO Option

P1D Series



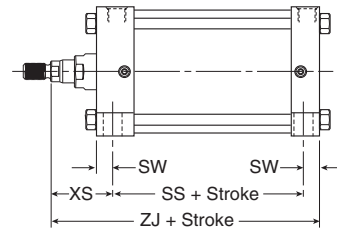
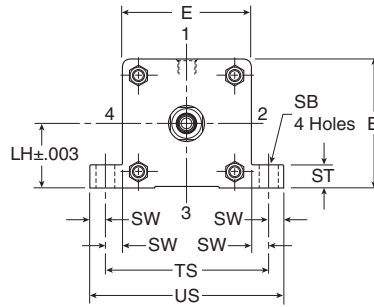
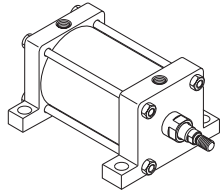
For inventory, lead time, and kit lookup, visit [www.pdnplu.com](http://www.pdnplu.com)

**Style C, F**

**Tie Rod Pneumatic Cylinders  
4MA/4ML Series – 6” and 8” Bore Size**

**Side Lug**

Style C  
(NFPA MS2)

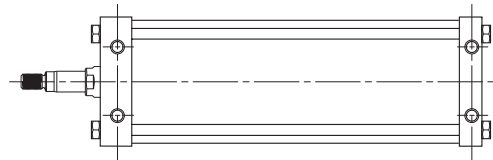
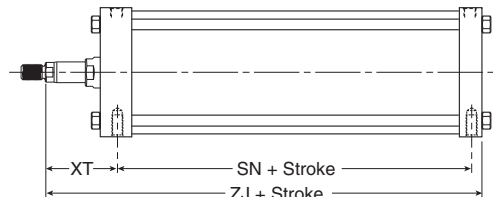
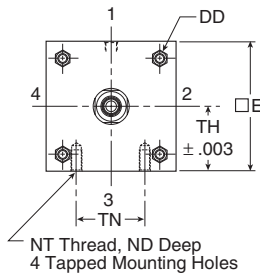
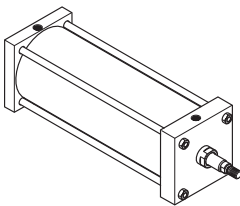


**Style C Dimensions**

Bore size	Rod no.	Rod dia. MM	E	+/- .003 LH	SB	ST	SW	TS	US	XS	Add stroke	
											SS	ZJ
6	1	1-3/8	6.500	3.243	0.813	1.000	0.688	7.875	9.250	2.313	3.625	6.625
	3	1-3/4	6.500	3.243	0.813	1.000	0.688	7.875	9.250	2.563	3.625	6.875
8	1	1-3/8	8.500	4.243	0.813	1.000	0.688	9.875	11.250	2.313	3.750	6.750
	3	1-3/4	8.500	4.243	0.813	1.000	0.688	9.875	11.250	2.563	3.750	7.000

**Side Tap**

Style F  
(NFPA MS4)



**Style F Dimensions**

Bore size	Rod no.	Rod dia. MM	E	ND	NT	+/- .003 TH	TN	XT	Add stroke	
									SN	ZJ
6	1	1-3/8	6.500	1.125	3/4-10	3.243	3.250	2.813	3.125	6.625
	3	1-3/4	6.500	1.125	3/4-10	3.243	3.250	3.063	3.125	6.875
8	1	1-3/8	8.500	1.125	3/4-10	4.243	4.500	2.813	3.250	6.750
	3	1-3/4	8.500	1.125	3/4-10	4.243	4.500	3.063	3.250	7.000



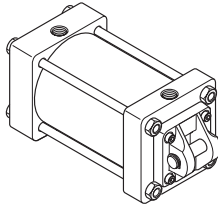
For inventory, lead times, and kit lookup, visit [www.pdnplu.com](http://www.pdnplu.com)

B30

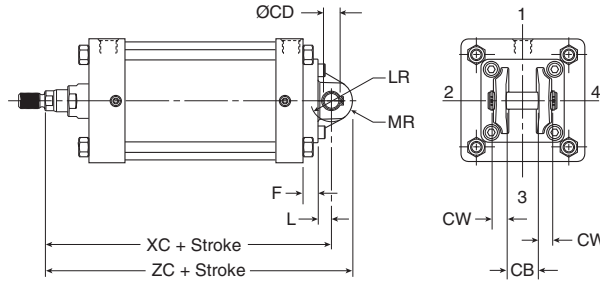
**Parker Hannifin Corporation**  
Pneumatic Division  
Richland, Michigan  
[www.parker.com/pneumatics](http://www.parker.com/pneumatics)

**Cap Fixed Clevis**

Style BB  
 (NFPA MP1)

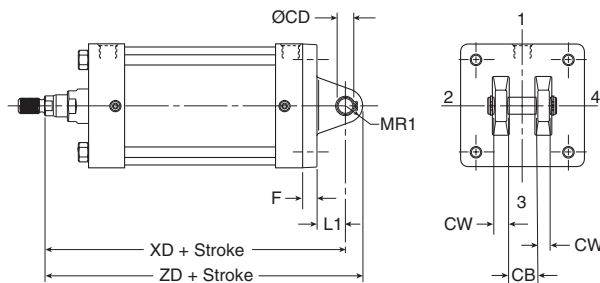
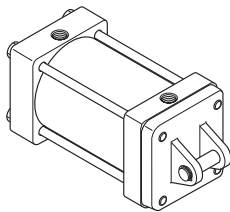


**Note:** For maximum swivel angle of BB mount with rear mounting plate, please reference cylinder accessories on page B80.



**Cap Detachable Clevis**

Style BC  
 (NFPA MP2)

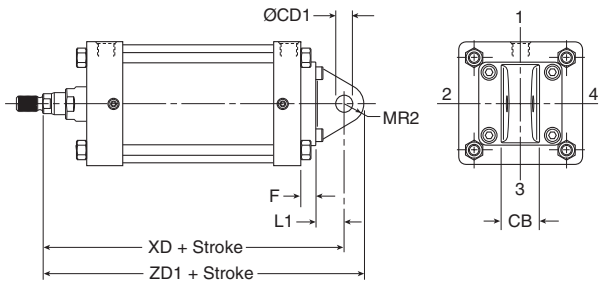
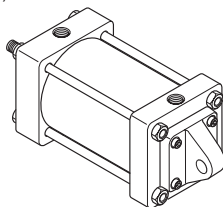


**Styles BB and BC Dimensions**

Bore size	Rod no.	Rod dia. MM	CB	Rod dia. +.000 -0.002 CD	CW	E	F	L	LR	L1	MR	MR1	Add stroke			
													XC	XD	ZC	ZD
6	1	1-3/8	1.500	1.001	0.750	6.500	0.750	0.750	1.250	1.500	1.125	1.000	8.125	8.875	9.250	9.875
	3	1-3/4	1.500	1.001	0.750	6.500	0.750	0.750	1.250	1.500	1.125	1.000	8.375	9.125	9.500	10.125
8	1	1-3/8	1.500	1.001	0.750	8.500	0.750	0.750	1.250	1.500	1.125	1.000	8.250	9.000	9.375	10.000
	3	1-3/4	1.500	1.001	0.750	8.500	0.750	0.750	1.250	1.500	1.125	1.000	8.500	9.250	9.625	10.250

**Cap Detachable Eye**

Style BE  
 (NFPA MP4)  
 (only 6" Bore)



**Style BE Dimensions**

Bore size	Rod no.	Rod dia. MM	CB	Rod dia. +.002 +.004 CD1	E	F	L1	MR2	Add stroke	
									XD	ZD1
6	1	1-3/8	1.500	1.000	6.500	0.750	1.500	1.125	8.875	10.000
	3	1-3/4	1.500	1.000	6.500	0.750	1.500	1.125	9.125	10.250

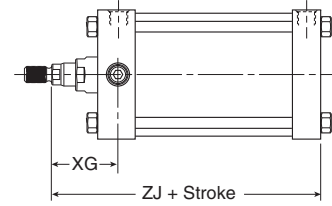
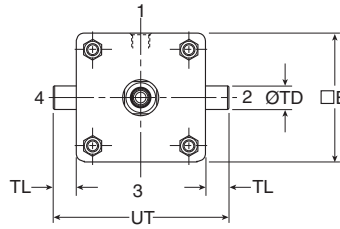
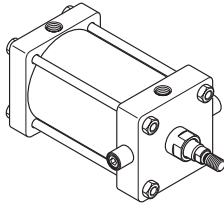
<b>B</b>	Tie Rod Pneumatic Cylinders
	4MA Series
4MAJ Series	
2MNR Series	
ACVB Option	
LPSO Option	
PID Series	



For inventory, lead time, and kit lookup, visit [www.pdnplu.com](http://www.pdnplu.com)

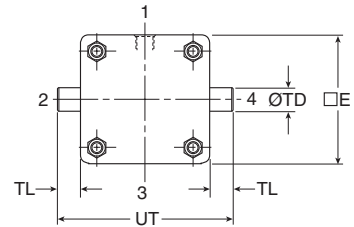
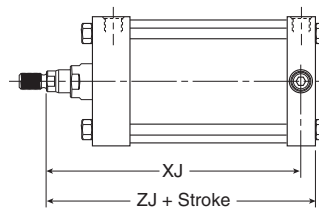
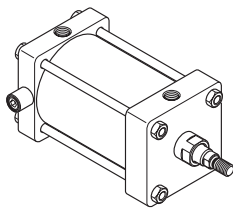
**Head Trunnion**

Style D  
 (NFPA MT1)



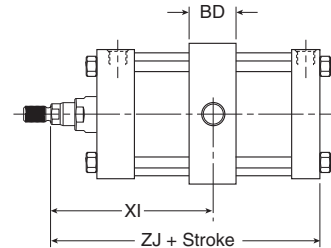
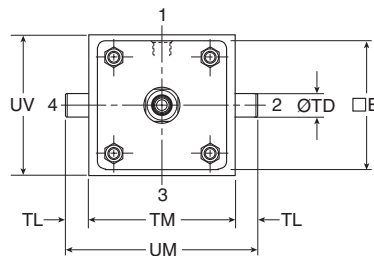
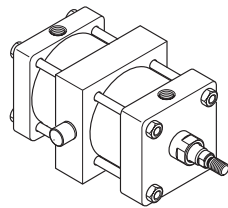
**Cap Trunnion**

Style DB  
 (NFPA MT2)



**Intermediate Trunnion**

Style DD  
 (NFPA MT4)



**Styles D, DB and DD Dimensions**

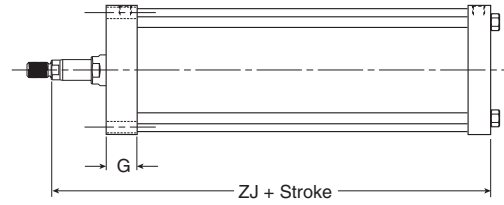
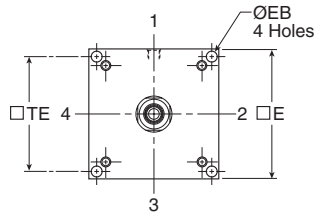
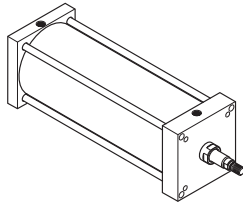
Bore size	Rod no.	Rod dia. MM	E	BD	Rod dia. +.000 -0.001 TD	TL	TM	UM	UT	UV	XG	Min. XI	Add stroke	
													XJ	ZJ
6	1	1-3/8	6.500	2.500	1.375	1.375	7.625	10.375	9.250	7.000	2.625	4.813	5.875	6.625
	3	1-3/4	6.500	2.500	1.375	1.375	7.625	10.375	9.250	7.000	2.875	5.063	6.125	6.875
8	1	1-3/8	8.500	2.500	1.375	1.375	9.750	12.500	11.250	9.500	2.625	4.750	6.000	6.750
	3	1-3/4	8.500	2.500	1.375	1.375	9.750	12.500	11.250	9.500	2.875	5.000	6.250	7.000



For inventory, lead times, and kit lookup, visit [www.pdnplu.com](http://www.pdnplu.com)

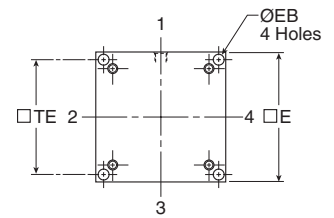
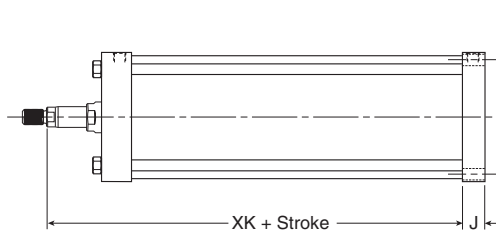
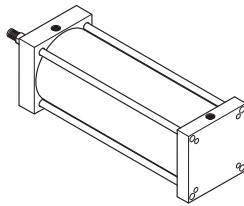
**Head Square**

Style JB  
 (NFPA ME3)



**Cap Square**

Style HB  
 (NFPA ME4)



**Styles JB and HB Dimensions**

Bore size	Rod no.	Rod dia. MM	E	EB	G	J	TE	Add stroke	
								XK	ZJ
8	1	1-3/8	8.500	0.688	1.810	1.440	7.570	5.313	6.750
	3	1-3/4	8.500	0.688	1.810	1.440	7.570	5.563	7.000

**B**

Tie Rod Pneumatic Cylinders

4MA Series

4MAJ Series

2MNR Series

ACVB Option

LPSO Option

P1D Series



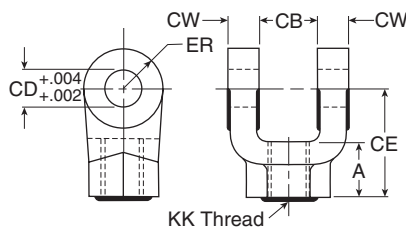
For inventory, lead time, and kit lookup, visit [www.pdnplu.com](http://www.pdnplu.com)

**Mounting Kits and Accessories**

Bore size	J (MF1)	H (MF2)	BB (MP1)	BC (MP2)	BE (MP4)	CB (MS1)	G (MS7)	Kit fastener torque units	
	Head rectangular flange	Cap rectangular flange	Cap fixed clevis	Cap detachable clevis	Cap detachable eye	Side end angles	Side end lug	inch-lbs	N-m
	Kit number	Kit number	Kit number	Kit number	Kit number	Kit number	Kit number		
1-1/2	L079700150	L079700150	L079710150	L079730150	L079720150	L079740150	L079750150	32-36	3.6-4.1
2	L079700200	L079700200	L079710200	L079730200	L079720200	L079740200	L079750200	72-82	8-9
2-1/2	L079700250	L079700250	L079710250	L079730250	L079720250	L079740250	L079750250	72-82	8-9
3-1/4	L079700325	L079700325	L079710325	L079730325	L079720325	L079740325	L079750325	216-228	24-25.3
4	L079700400	L079700400	L079710400	L079730400	L079720400	L079740400	L079750400	216-228	24-25.3
5	L079700500	L079700500	L079710500	L079730500	N/A	L079740500	N/A	360-372	41-42

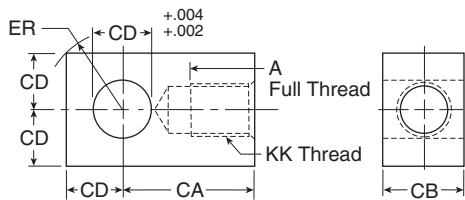
\*\* Spacer plate not used for 4" bore or double rod cylinders

**Female Rod Clevis**



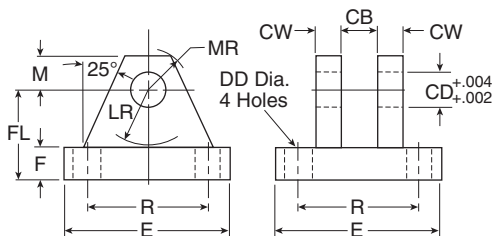
Symbol	1458030044	1458030050	1458030075	1458030088	1458030100	1458030125	1458030150
A	3/4	3/4	1-1/8	1-5/8	1-5/8	2	2-1/4
CB	3/4	3/4	1-1/4	1-1/2	1-1/2	2	2-1/2
CD	1/2	1/2	3/4	1	1	1-3/8	1-3/4
C E	1-1/2	1-1/2	2-1/8	2-15/16	2-15/16	3-3/4	4-1/2
CW	1/2	1/2	5/8	3/4	3/4	1	1-1/4
ER	1/2	1/2	3/4	1	1	1-3/8	1-3/4
KK	7/16-20	1/2-20	3/4-16	7/8-14	1-14	1-1/4-12	1-1/2-12
Load capacity (lbs)	4250	4900	11200	18800	19500	33500	45600

**Rod Eye Knuckle**



Symbol	1458040044	1458040050	1458040075	1458040088	1458040100	1458040125	1458040150
A	3/4	3/4	1-1/8	1-1/8	1-5/8	2	2-1/4
CA	1-1/2	1-1/2	2-1/16	2-3/8	2-13/16	3-7/16	4
CB	3/4	3/4	1-1/4	1-1/2	1-1/2	2	2-1/2
CD	1/2	1/2	3/4	1	1	1-3/8	1-3/4
ER	23/32	23/32	1-1/16	1-7/16	1-7/16	1-31/32	2-1/2
KK	7/16-20	1/2-20	3/4-16	7/8-14	1-14	1-1/4-12	1-1/2-12
Load capacity (lbs)	5000	5700	12100	13000	21700	33500	45000

**Clevis Bracket**

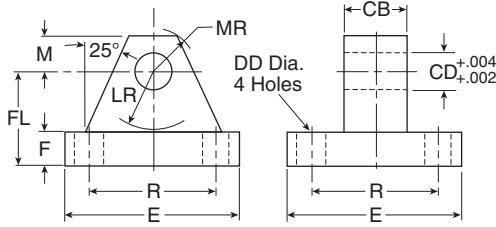


Symbol	1458050044	1458050050	1458050075	1458050100	1458050138	1458050175
CB	15/32	3/4	1-1/4	1-1/2	2	2-1/2
CD	7/16	1/2	3/4	1	1-3/8	1-3/4
CW	3/8	1/2	5/8	3/4	1	1-1/4
DD	17/64	13/32	17/32	21/32	21/32	29/32
E	2-1/4	3-1/2	5	6-1/2	7-1/2	9-1/2
F	3/8	1/2	5/8	3/4	7/8	7/8
FL	1	1-1/2	1-7/8	2-1/4	3	3-5/8
LR	5/8	3/4	1-3/16	1-1/2	2	2-3/4
M	3/8	1/2	3/4	1	1-3/8	1-3/4
MR	1/2	5/8	29/32	1-1/4	1-21/32	2-7/32
R	1.75	2.55	3.82	4.95	5.73	7.50
Load capacity (lbs)	3600	7300	14000	19200	36900	34000



For inventory, lead times, and kit lookup, visit [www.pdnplu.com](http://www.pdnplu.com)

**Mounting Plate & Eye Bracket**



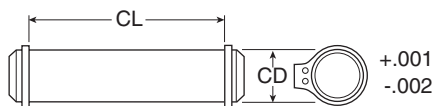
Symbol	1458060031	1458060050	1458060075	1458060100	1458060138	1458060175
CB	15/16	3/4	1-1/4	1-1/2	2	2-1/2
CD	15/16	1/2	3/4	1	1-3/8	1-3/4
DD	17/64	13/32	17/32	21/32	21/32	29/32
E	2-1/4	2-1/2	3-1/2	4-1/2	5	6-1/2
F	3/8	3/8	5/8	7/8	7/8	1-1/8
FL	1	1-1/8	1 7/8	2-3/8	3	3-3/8
LR	5/8	3/4	1-1/4	1-1/2	2-1/8	2-1/4
M	3/8	1/2	3/4	1	1-3/8	1-3/4
MR	1/2	9/16	7/8	1-1/4	1-5/8	2-1/8
R	1.75	1.63	2.55	3.25	3.82	4.95
Load Capacity (lbs)	1700	4100	10500	20400	21200	49480

**1-1/2" to 8" Bore Cylinder Accessories**

Rod end accessories can be selected by cylinder rod end thread size from Tables A & B below. Mating parts for rod end accessories are listed just to the right of the knuckle or clevis selected. Mounting plates for style MP1 & MP4 cylinder mounts are selected by bore size from Table C.

Rod end thread size	Table A			Table B			Table C		
	Female rod clevis	Mating parts		Knuckle	Mating parts		Bore size	Mounting plates	
		Eye bracket	Pivot pin		Clevis bracket	Pivot pin		For mtg. style MP1 cylinder	For mtg. style MP4 cylinder
7/16-20	1458030044	1458060050	0856640050	1458040044	1458050050	0856640050	1-1/2	1458060050	1458050050
1/2-20	1458030050	1458060050	0856640050	1458040050	1458050050	0856640050	2	1458060050	1458050050
3/4-16	1458030075	1458060075	0856640075	1458040075	1458050075	0856640075	2-1/2	1458060050	1458050050
7/8-14	1458030088	1458060100	0856640100	1458040088	1458050100	0856640100	3-1/4	1458060075	1458050075
1-14	1458030100	1458060100	0856640100	1458040100	1458050100	0856640100	4	1458060075	1458050075
1-1/4-12	1458030125	1458060138	0856640138	1458040125	1458050138	0856640138	5	1458060075	—
1-1/2-12	1458030150	1458060175	0856640175	1458040150	1458050175	0856640175	6	1458060100	—
							8	1458060100	—

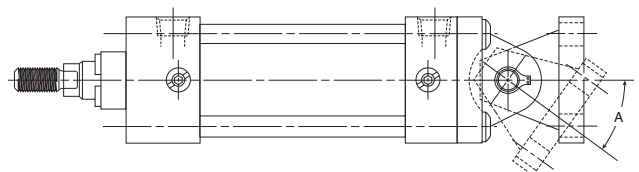
**Pivot Pin**



Symbol	0856640044	0856640050	0856640075	0856640100	0856640138	0856640175
CD	7/16	1/2	3/4	1	1-3/8	1-3/4
CL	1-5/16	1-7/8	2-5/8	3-1/8	4-1/8	5-3/16
Shear cap. (lbs)	6600	8600	19300	34300	65000	105200

**Note:** Pivot Pin must be ordered separately for single lug pivot mounting.

**Maximum pivot angle for rear clevis mounts (BB mounts) and accessories**



Bore	1-1/2	2	2-1/2	3-1/4	4	5	6	8
Angle A	52	43	29	50	49	45	42	42



For inventory, lead time, and kit lookup, visit [www.pdnplu.com](http://www.pdnplu.com)

B35

**Parker Hannifin Corporation**  
 Pneumatic Division  
 Richland, Michigan  
[www.parker.com/pneumatics](http://www.parker.com/pneumatics)

**Service Kits**

Bore size	Rod dia.	Rod no.	RG - Rod gland cartridge kit. Includes gland and wiper, rod, and o-ring seals				Gland to head torque units		PK - Piston seal kit, standard lipseals. Includes piston and o-ring seals		SK - complete cylinder kit. Includes rod gland kit, piston seal kit, and cushion kits		Torque units endcap fastener or tie rod	
			Nitrile seal kit number	Fluorocarbon seals kit number	ft-lbs	Nm	Nitrile seal kit number	Fluorocarbon seal kit number	Nitrile seal kit number	Fluorocarbon seal kit number	inch-lbs	Nm		
1-1/2	5/8	1	RG04MA0061	RG04MA0065	40-45	54-61	PK1504MA01	PK1504MA05	SK15104MA1	SK15104MA5	32-36	3.6-4.1		
	1	2	RG04MA0101	RG04MA0105	45-50	61-68			SK15304MA1	SK15304MA5				
2	5/8	1	RG04MA0061	RG04MA0065	40-45	54-61	PK2004MA01	PK2004MA05	SK20104MA1	SK20104MA5	72-82	8-9		
	1	3	RG04MA0101	RG04MA0105	45-50	61-68			SK20304MA1	SK20304MA5				
2-1/2	5/8	1	RG04MA0061	RG04MA0065	40-45	54-61	PK2504MA01	PK2504MA05	SK25104MA1	SK25104MA5	72-82	8-9		
	1	3	RG04MA0101	RG04MA0105	45-50	61-68			SK25304MA1	SK25304MA5				
3-1/4	1	1	RG04MA0101	RG04MA0105	45-50	61-68	PK3254MA01	PK3254MA05	SK32104MA1	SK32104MA5	216-228	24-25.3		
	1-3/8	3	RG04MA0131	RG04MA0135	75-80	102-108			SK32304MA1	SK32304MA5				
4	1	1	RG04MA0101	RG04MA0105	45-50	61-68	PK4004MA01	PK4004MA05	SK40104MA1	SK40104MA5	216-228	24-25.3		
	1-3/8	3	RG04MA0131	RG04MA0135	75-80	102-108			SK40304MA1	SK40304MA5				
5	1	1	RG04MA0101	RG04MA0105	45-50	61-68	PK5004MA01	PK5004MA05	SK50104MA1	SK50104MA5	360-372	41-42		
	1-3/8	3	RG04MA0131	RG04MA0135	75-80	102-108			SK50304MA1	SK50304MA5				
6	1-3/8	1	RG04MA0131	RG04MA0135	75-80	102-108	PK6004MA01	PK6004MA05	SK60104MA1	SK60104MA5	420-432	48-49		
	1-3/4	3	RG04MA0171	RG04MA0175	90-95	122-129			SK60304MA1	SK60304MA5				
8	1-3/8	1	RG04MA0131	RG04MA0135	75-80	102-108	PK8004MA01	PK8004MA05	SK80104MA1	SK80104MA5	960-972	109-115		
	1-3/4	3	RG04MA0171	RG04MA0175	90-95	122-129			SK80304MA1	SK80304MA5				

**B**  
Tie Rod Pneumatic Cylinders

4MA Series

4MAJ Series

2MNR Series

ACVB Option

LPSO Option

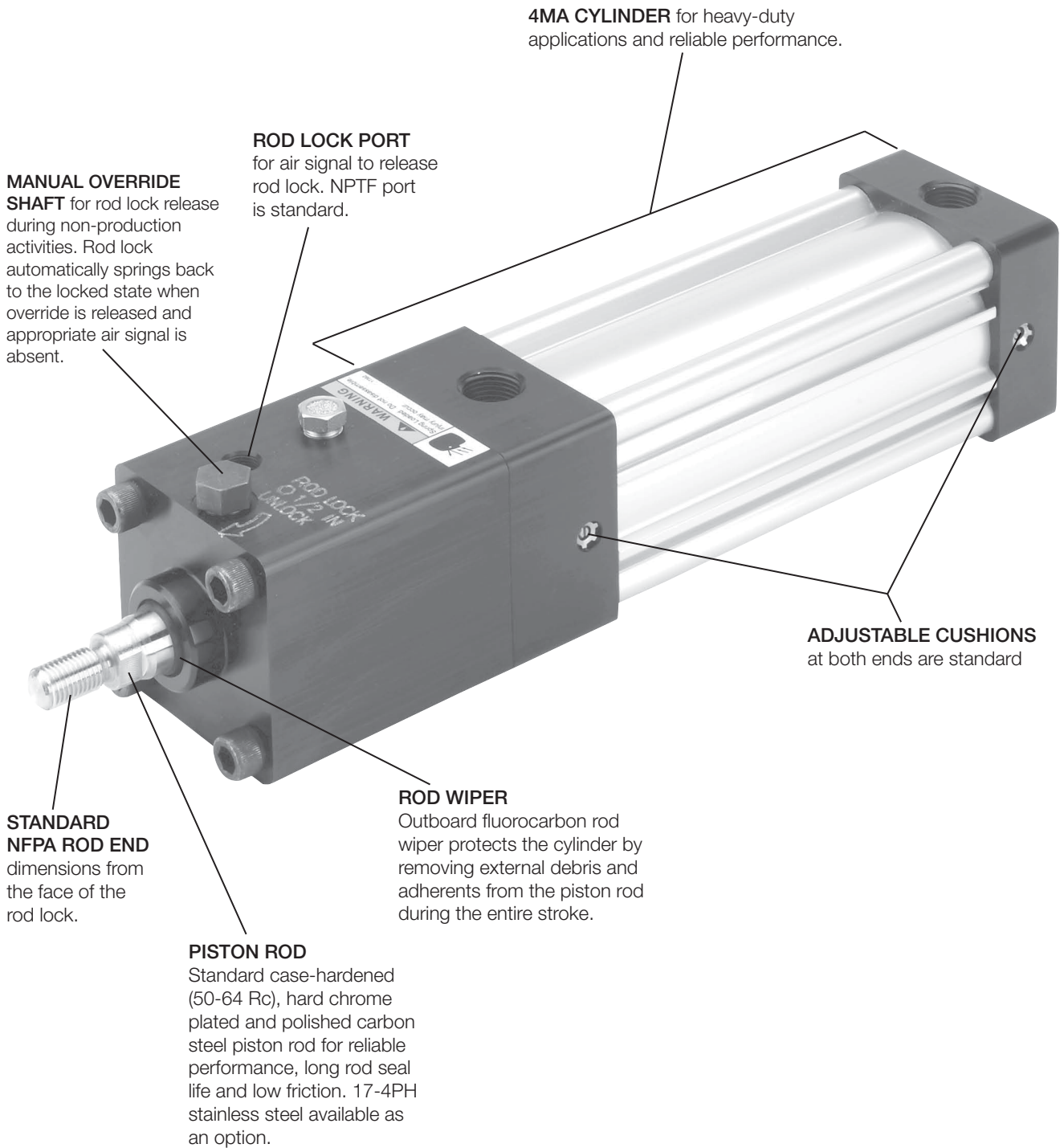
P1D Series



For inventory, lead times, and kit lookup, visit [www.pdnplu.com](http://www.pdnplu.com)



**4MAJ Series – Rod Lock**



<b>B</b>	Tie Rod Pneumatic Cylinders
	4MA Series
4MAJ Series	
2MNR Series	
ACVB Option	
LPSO Option	
P1D Series	



For inventory, lead time, and kit lookup, visit [www.pdnplu.com](http://www.pdnplu.com)

B37

**Parker Hannifin Corporation**  
 Pneumatic Division  
 Richland, Michigan  
[www.parker.com/pneumatics](http://www.parker.com/pneumatics)

**NFPA Non-Lube Pneumatic Cylinder with Manual Override Rod Lock**

Rod lock version 4MA Series (the 4MAJ) provides precise load holding with virtually zero backlash and features high accuracy for demanding applications. The rod lock is a spring-activated type with air pressure release and clamps the piston rod to lock it into position. In the absence of an appropriate air signal, full holding force is applied to the piston rod. When a 60 PSI (or greater) air signal is present, the locking device is released. All rod locks include a manual override shaft to free the rod lock without air pressure during non-production activities.

**Some key benefits of the 4MAJ Series Cylinders**

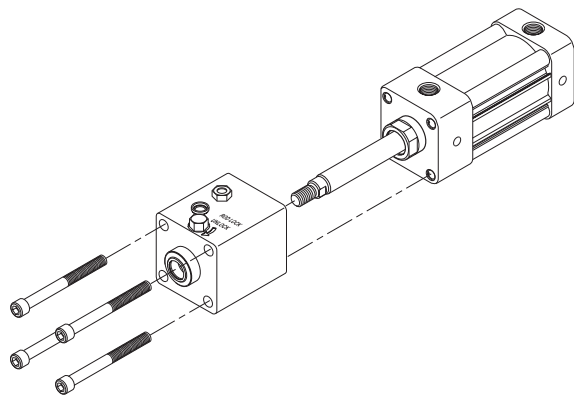
**Bolt-On Modularity** – As a true cylinder accessory, the rod lock may be removed without affecting the base cylinder (1-1/2" to 5" bores). The same, great cylinder remains intact, allowing the rod lock to bolt-on with minimal length change. This modularity can be extremely important for special installations or while servicing the cylinder. Rod locks for 6" - 8" bores and all Style DD mounts (NFPA MT4) are fastened to the base cylinder using the base cylinder's tie rods. See drawings below.

**Aesthetics** – we have designed our rod locks with the same anodized aluminum extrusion used for the cylinder endcaps, resulting in a virtually seamless assembly. In addition, we focused every effort to create the shortest overall package, minimizing the need for customers to accommodate significantly longer cylinder lengths.

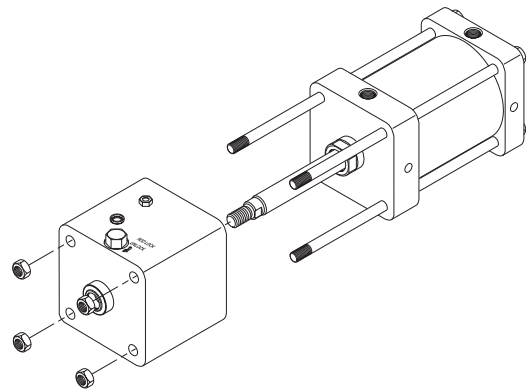
**Functionality** – With a holding force corresponding to 100 PSI on the cap end for nearly every bore size, the rod lock can be used for a variety of holding applications. The manual override shaft allows occasional release of the piston rod and automatically returns the rod lock back to the locked state when it is released and the appropriate air signal is absent. The front pilot diameter meets NFPA specifications and facilitates proper installation of the cylinder to customer equipment or cylinder accessories.

**Ease of Order Entry** – To order 4MA Series with the rod lock option, just change the product series to 4MAJ (the "J" is required for the rod lock option). See model code on page B40 for additional information.

**1-1/2" to 5" Bores**



**6" to 8" Bores and all style DD mounts (NFPA MT4)**



B	Tie Rod Pneumatic Cylinders	4MA Series
		4MAJ Series
	2MNR Series	
	ACVB Option	
	LPSO Option	
	P1D Series	



For inventory, lead times, and kit lookup, visit [www.pdnplu.com](http://www.pdnplu.com)

**NFPA Non-Lube Pneumatic Cylinder with Manual Override Rod Lock**

**Connection**

The signal air for the locking device can be obtained directly from a main air supply, or from the air supply serving the valve that controls the cylinder itself. For controlled ON/OFF operation of the locking device, a separate quick-venting valve is used.

The piston rod should not be moving when the locking device is activated. The locking device is not intended to brake a movement in repeated sequences.

**NOTE:** The 4MAJ is not intended for use in water service applications, or in environments that have high humidity levels and/or splashing fluids present.

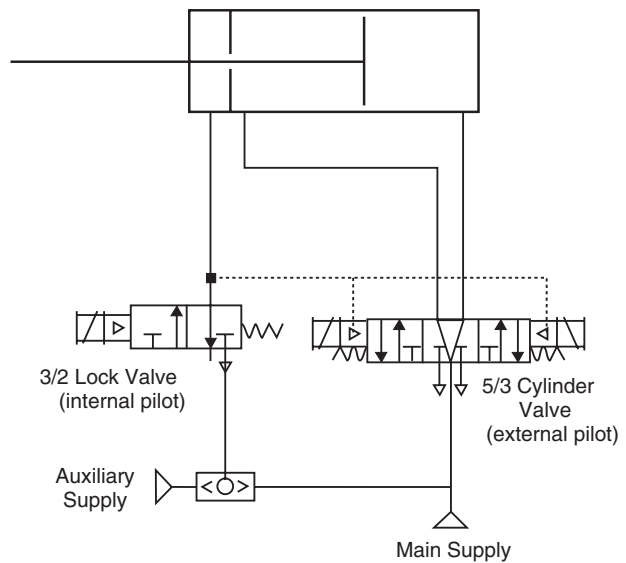
**NOTE:** Exhaust air from the rod lock can be piped away when there are demands for a contaminant-free environment.

Operation at pressures lower than 60 PSI may lead to inadvertent engagement of the rod lock device.

**Other Cylinder and Rod Lock Features:**

- The 4MAJ rod lock will operate in both directions, engaging with the same holding force.
- The 4MAJ can be mounted in any position.
- Piston rod rotation is not allowed when the rod lock is engaged (not intended for torsional braking).
- Rod lock is suitable for infrequent dynamic braking (emergency stops). Since the 4MAJ rod lock is designed for static applications, repeated dynamic stops will cause rod and/or bearing wear and reduce holding forces.
- The rated holding force corresponds to static load conditions. If the rated value is exceeded, slipping and other problems may occur.
- If personal safety is required, an unrelated, redundant safety system is recommended.

**Sample Pneumatic Circuit**



1. Lock valve must be maintained energized during cylinder motion, otherwise rod lock is engaged and cylinder valve shifts to mid position.
2. Cylinder valve must be maintained energized during extend or retract. Also keep energized at end of stroke until change of direction is desired.
3. Mid position of 5/3 Cylinder valve may be pressurized outlets if the combination of pressure load on the cylinder and inertia effects of the attached load do not exceed the holding force rating of the rod lock device, including allowance for wear.
4. Do not use cylinder lines for any logic functions – pressure levels vary too much.

**Basic Rod Lock Specifications**

Bore size	Rod no.	Rod dia. MM	Air chamber volume (in <sup>3</sup> )	Engagement time (seconds)	Rated holding force (lbs)	Minimum torque to override (ft-lbs to hex shaft)
1-1/2	1	5/8	0.25	0.030	180	2
2	1	5/8	0.71	0.040	314	5
	3	1	0.68	0.040	250	5
2-1/2	1	5/8	1.26	0.045	491	7
	3	1	1.49	0.050	491	7
3-1/4	1	1	3.20	0.070	830	17
	3	1-3/8	2.11	0.060	830	17
4	1	1	6.73	0.100	1,256	45
	3	1-3/8	4.78	0.100	1,256	45
5	1	1	11.50	0.150	1,963	72
	3	1-3/8	9.50	0.130	1,963	72
6	1	1-3/8	14.08	0.175	2,830	135
	3	1-3/4	12.75	0.165	2,830	135
8	1	1-3/8	22.66	0.265	5,026	160
	3	1-3/4	23.21	0.265	5,026	160

**Note:** This specification data applies only to the rod lock part of the 4MAJ cylinder.

For cylinder volume and performance, please use cylinder dimensions and application criteria.



For inventory, lead time, and kit lookup, visit [www.pdnplu.com](http://www.pdnplu.com)

# Tie Rod Pneumatic Cylinders 4MAJ Series, Rod Lock Option

## Features

- Industry leading NFPA interchangeable rod lock cylinder with flexible construction
- Rod lock holding force equivalent to cylinder output force at 100 PSIG
- Bore sizes – 1-1/2", 2", 2-1/2", 3-1/4", 4", 5", 6" and 8"
- 17 standard styles mounting styles available
- Available in any practical stroke length
- Rod diameters – 5/8", 1", 1-3/8" and 1-3/4"
- Single rod end or double rod ends
- Adjustable cushions are standard at both ends
- Manual override feature standard on all configurations



## Operating information

Operating pressure: 100 PSIG (7 bar) maximum air pressure, except 2" bore with 1" rod rated at 80 PSIG)  
60 PSIG (4.1 bar) minimum air pressure to release rod lock

Temperature range –  
Standard seals -10°F to 165°F (-23°C to 74°C)  
Fluorocarbon seals -10°F to 250°F (-23°C to 121°C)

Filtration requirements: 40 micron, dry filtered air

## Ordering information

<b>2.00</b>	<b>C</b>	<b>J</b>	<b>4MAJ</b>	<b>U</b>	<b>1</b>	<b>4</b>	<b>A</b>	<b>C</b>	<b>6.000</b>
<b>Bore size</b> 1.50 <sup>1</sup> 2.00 2.50 3.25 4.00 5.00 6.00 <sup>11</sup> 8.00 <sup>11</sup>	<b>Double Rod Cylinder</b> <sup>12</sup> Specify "K" only if double rod cylinder is required.	<b>Mounting style</b> Specify mounting style code (see table on following page).	<b>Series</b> 4MAJ 4MA rod lock cylinder	<b>Ports</b> <sup>4</sup> <b>U</b> NPTF <b>R</b> BSPP <b>B</b> BSPT <b>T</b> SAE	<b>Piston rod number</b> Specify rod code number for required diameter. <sup>6</sup>	<b>Special modification</b> Specify "S" only for special modification other than rod end, and then describe modification in item notes. (Includes 4MAJ with Linear Position Sensor Option) <sup>7</sup>	<b>Piston rod thread type</b> <b>A</b> Standard (UNF unified thread) <b>W</b> BSF British fine <b>M*</b> Metric	<b>Cushion cap end</b> <b>C</b> Cushioned cap end "C" is required	<b>Stroke length</b> Specify stroke length required in inches. <sup>8</sup>
<b>Cushion head end</b> <b>C</b> Cushioned head end "C" is required	<b>Cylinder construction</b>		<b>Seals</b>		<b>Piston rod thread style</b>		<b>Rod material and gland code</b>		
<b>Blank*</b> Standard (extruded body, standard round lobe orientation)	<b>A*</b> Extruded body, round lobe orientation rotated 90 degrees from standard		<b>Blank</b> Standard (nitrile seals)		<b>4</b> Small male		<b>Blank</b> Standard rod and gland		
<b>N*</b> Extruded body, round lobe orientation rotated 180 degrees from standard	<b>N*</b> Extruded body, round lobe orientation rotated 180 degrees from standard		<b>V</b> Fluorocarbon seals <sup>5</sup>		<b>8</b> Intermediate male		<b>H</b> Standard rod and HI LOAD gland		
<b>Z*</b> Extruded body, round lobe orientation rotated 270 degrees from standard	<b>Z*</b> Extruded body, round lobe orientation rotated 270 degrees from standard		<b>E</b> Fluorocarbon rod wiper and rod seal only <sup>6</sup>		<b>9</b> Short female		<b>Y</b> 17-4 PH stainless steel rod and standard gland		
<b>T</b> Aluminum round tube and carbon steel tie rods & nuts	<b>T</b> Aluminum round tube and carbon steel tie rods & nuts				<b>55</b> For use with split coupler <sup>9</sup>		<b>Z</b> 17-4 PH stainless steel rod and HI LOAD gland		
<sup>*</sup> Please reference table on page B5. Only applies to 1-1/2" to 4" bore.									
<b>Piston type</b> <sup>11</sup>									
<b>Blank</b>	Lipseals and magnetic ring (legacy) (standard for 4ML)								
<b>1</b>	Lipseals, no magnetic ring (legacy)								
<b>2</b>	Lipseals, no magnetic ring (aluminum piston)								
<b>3</b>	Lipseals and magnetic ring (aluminum piston)								
<b>4</b>	Bumper seals, no magnetic ring								
<b>6</b>	Bumper seals and magnetic ring								
<b>B</b>	Lipseals, 1/4" thick bumpers both ends <sup>3</sup>								
<b>H</b>	Lipseals, 1/4" thick bumper head end <sup>3</sup>								
<b>C</b>	Lipseals, 1/4" thick bumper cap end <sup>3</sup>								
<b>D</b>	Lipseals and magnetic ring, 1/4" thick bumpers both ends <sup>3</sup>								
<b>F</b>	Lipseals and magnetic ring, 1/4" thick bumper head end <sup>3</sup>								
<b>R</b>	Lipseals and magnetic ring, 1/4" thick bumper cap end <sup>3</sup>								

<sup>1</sup> Not available with 1" rod diameter (rod number 2) for 1-1/2" bore. Not available with Linear Position Sensor Option (LPSO).

<sup>3</sup> Addition of 1/4" bumper results in a 1/4" stroke loss per bumper, per end. For example, a 6" stroke cylinder with 1/4" bumpers at both ends (option B) has an effective stroke of 5-1/2".

<sup>4</sup> Port thread styles only for base cylinder. Rod lock port is always NPTF. If a different rod lock port thread style is required, place an "S" for special in the Special Modification field and indicate the desired rod lock port thread style in the item notes.

<sup>5</sup> Fluorocarbon seals for 4MAJ are only for external chemical compatibility applications, not high temperature.

<sup>6</sup> Used for external chemical compatibility applications, not high temperature.

<sup>7</sup> For Linear Position Sensor Option (LPSO), please include the following information for the Special Modification item notes:  
a. Sensor part number (please reference pages B72-B76)  
b. Sensor position  
c. Port position (if other than position 1)  
d. Length of stop tubing, gross stroke and net stroke (if required)

<sup>8</sup> Review Piston Rod Selection Chart, please reference page A14 to determine proper piston rod diameter.

<sup>9</sup> For additional information regarding this style, please reference page B77. If non-standard Rod Material and Gland Code is required with this option, please place an "S" for special in Special Modification field and specify Rod Material and Gland Code in the item notes.

<sup>10</sup> If a stop tube is required, specify gross stroke (net stroke + stop tube) in the model number, then place an "S" for special in the Special Modification field and specify the stop tube length in the item notes. Not available with Piston Types (blank) and 1 for 1-1/2" - 5" bore cylinders.

<sup>11</sup> 6"-8" bore 4MAJ can accept only Piston Types (blank) and 3. The (blank) piston for 6"-8" bores is aluminum, lipseals, no magnetic ring. Composite pistons not available with oversize rod number 3.

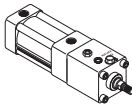
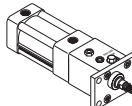
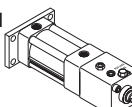
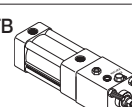
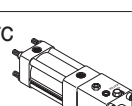
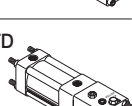
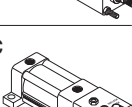
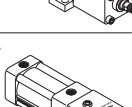
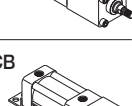
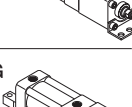
\* Please reference page B78.

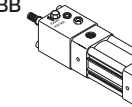
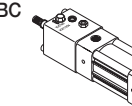
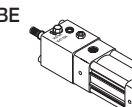
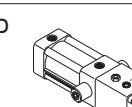
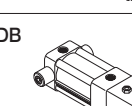
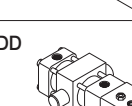
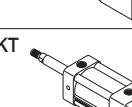
For ordering purposes, when special options or common modifications are requested, the factory will assign a sequential part number in place of the model number.



For inventory, lead times, and kit lookup, visit [www.pdnplu.com](http://www.pdnplu.com)

**Mounting Styles**

Mounting style	NFPA mounting	Description	4MAJ	Bore size
	MX0	No Mount	4MAJ	1-1/2 - 8
			w/LPSO	2 - 8
			w/LPSO w/stop tube	2 - 8
	MF1	Head Rectangular Flange	4MAJ	1-1/2 - 6
			w/LPSO	2 - 6 *
			w/LPSO w/stop tube	2 - 6
	MF2	Cap Rectangular Flange	4MAJ	1-1/2 - 6
			w/LPSO	2 - 6 *
			w/LPSO w/stop tube	2 - 6 *
	MX3	Tie Rods Extended Head End	4MAJ	1-1/2 - 8
			w/LPSO	2 - 6 *
	MX2	Tie Rods Extended Cap End	4MAJ	1-1/2 - 8
	MX1	Tie Rods Extended Both Ends	4MAJ	1-1/2 - 8
	MS2	Side Lug	4MAJ	1-1/2 - 8
			w/LPSO	2 - 8
			w/LPSO w/stop tube	2 - 8
	MS4	Side Tap	4MAJ	1-1/2 - 8
			w/LPSO	2 - 8
			w/LPSO w/stop tube	2 - 8
	MS1	Side End Angle	4MAJ	1-1/2 - 8
			w/LPSO	2 - 8
			w/LPSO w/stop tube	2 - 8
	MS7	Side End Lug	4MAJ	1-1/2 - 4
			w/LPSO	2 - 4
			w/LPSO w/stop tube	2 - 4

Mounting style	NFPA mounting	Description	4MAJ	Bore size
	MP1	Cap Fixed Clevis	4MAJ	1-1/2 - 8
			w/LPSO	2 - 8 *
			w/LPSO w/stop tube	2 - 8 *
	MP2	Cap Detachable Clevis	4MAJ	1-1/2 - 8
			w/LPSO	2 - 8 *
			w/LPSO w/stop tube	2 - 8 *
	MP4	Cap Detachable Eye	4MAJ	1-1/2 - 6
			w/LPSO	2 - 6 *
			w/LPSO w/stop tube	2 - 6 *
	MT1	Head Trunnion	4MAJ	1-1/2 - 8
			w/LPSO	2 - 8
			w/LPSO w/stop tube	2 - 8
	MT2	Cap Trunnion	4MAJ	1-1/2 - 8
			w/LPSO	2 - 8 *
			w/LPSO w/stop tube	2 - 8 *
	MT4	Intermediate Trunnion	4MAJ	1-1/2 - 8
	MDX0	Double Rod End, No Mount	4MAJ	1-1/2 - 8
			w/LPSO	2 - 8
			w/LPSO w/stop tube	2 - 8

\* May interfere with mounting. Please provide clearance for Linear Sensor overhang (see page B73).

**B**  
Tie Rod Pneumatic Cylinders  
4MA Series  
4MAJ Series  
2MNR Series  
ACVB Option  
LPSO Option  
P1D Series

**Sensors**

See section L for sensors.



For inventory, lead time, and kit lookup, visit [www.pdnplu.com](http://www.pdnplu.com)

**General Specifications**

- NFPA interchangeable\*
- Bore sizes – 1-1/2", 2", 2-1/2", 3-1/4", 4", 5", 6" and 8"
- Strokes – available in any practical stroke length
- Rod diameters – 5/8", 1", 1-3/8" and 1-3/4"
- Rod end styles – 4 standard, specials available
- Single rod end or double rod ends
- Cushions – required and adjustable at both ends
- Operating pressure –  
 100 PSIG (6.9 bar)\*\* maximum air service, except for  
 2" bore with 1" rod (rated at 80 PSIG)  
 60 PSIG (4.1 bar) minimum air pressure to release  
 rod lock

- Media – dry, filtered air
- Temperature range –  
 -10°F to 165°F (-23°C to 74°C)
- Mounting styles – 18 standard styles

\* NFPA standards do not specify rod lock cylinder dimensions. The 4MA cylinder and mounting accessories subscribe to NFPA standards.

\*\* The pressure ratings are for these devices as stated. However, the rated holding forces of the rod locks are as stated on page B62.

For material options, including seals and piston rods, please see Material Specifications on below.

**Cylinder Weights**

Bore (inch)	Rod (inch)	No Mount Single Rod		No Mount Double Rod	
		Base wt. (lbs.)	Per inch (lbs.)	Base wt. (lbs.)	Per inch (lbs.)
1-1/2	0.625	4.23	0.20	4.66	0.28
	1.00	6.49	0.35	7.84	0.58
2	0.625	5.90	0.21	6.55	0.30
	1.00	6.49	0.35	7.84	0.58
2-1/2	0.625	7.75	0.23	8.46	0.31
	1.00	8.56	0.37	10.24	0.60
3-1/4	1.00	13.95	0.42	15.15	0.64
	1.375	15.93	0.62	19.46	1.05
4	1.00	20.80	0.49	22.32	0.71
	1.375	22.29	0.69	26.37	1.12
5	1.00	31.20	0.61	33.84	0.84
	1.375	32.72	0.81	36.89	1.24
6	1.375	55.50	0.87	60.63	1.30
	1.75	57.61	1.13	65.41	1.82
8	1.375	94.50	1.25	100.15	1.68
	1.75	96.63	1.51	104.90	2.20

**Standard Cushion Position**

Mounting Code	Position
All except D, DB, DD	2
D, DB, DD	3

**Standard Cylinder Port Sizes**

Bore	NPTF / BSPT	BSPP	SAE
1-1/2	3/8	G3/8	6
2	3/8	G3/8	6
2-1/2	3/8	G3/8	6
3-1/4	1/2	G1/2	10
4	1/2	G1/2	10
5	1/2	G1/2	10
6	3/4	G3/4	12
8	3/4	G3/4	12

Port thread styles for base cylinder only. Rod lock port is always NPTF. If a different rod lock port thread style is required, place an "S" for special in the Special Modification field and indicate the desired rod lock port thread style in the item notes. Standard rod lock port sizes are detailed in cylinder dimension tables.

**Mounting Weight Adders**

Bore (inch)	Weight (lbs) by mounting style							
	J, H	D, DB	BB	CB, G	DD	BE	C	BC
1-1/2	0.51	0.50	0.15	0.36	1.70	0.23	0.15	0.20
2	0.76	0.50	0.26	0.65	2.38	0.32	0.15	0.29
2-1/2	1.13	0.50	0.38	1.05	3.00	0.42	0.15	0.41
3-1/4	2.76	0.50	0.98	1.38	5.35	1.26	0.35	1.06
4	4.05	0.50	1.35	2.20	6.75	1.62	0.35	1.49
5	6.46	0.50	1.20	4.29	8.77	1.26	0.57	2.41
6	10.74	1.22	2.91	5.88	15.52	2.91	0.69	11.38
8	N/A	1.22	2.91	7.84	25.01	N/A	0.67	17.31

**Standard Temperatures and Applications**

Same as 4MA for 4MAJ, with the following additions/changes:

Piston rod (other materials not available)	Case-hardened, chrome plated carbon steel (standard) 17-4 PH stainless steel, chrome plated.
Rod lock housing	Black anodized aluminum alloy
Rod lock wiper	Fluorocarbon
Manual override shaft	416 stainless steel
Rod lock screws	Black oxidized steel alloy

**P**  
 Tie Rod Pneumatic Cylinders  
 4MA Series  
 4MAJ Series  
 2MNR Series  
 ACVB Option  
 LPSO Option  
 P1D Series



For inventory, lead times, and kit lookup, visit [www.pdnplu.com](http://www.pdnplu.com)

### How to Select a 4MAJ Cylinder

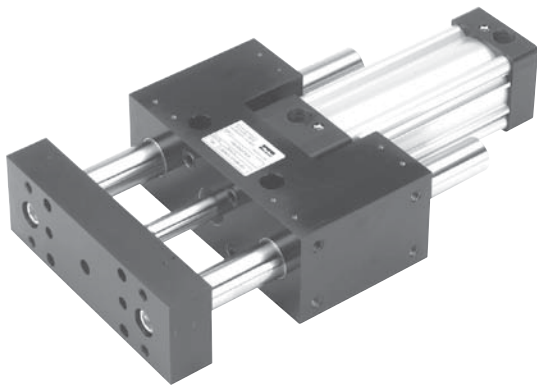
Parker cylinders are available based on air operating pressure. The many styles, sizes and optional features available assure that your application requirements are precisely met. To select a cylinder, follow these simple steps:

- Step 1 - **Determine the correct cylinder bore size** necessary to achieve required force using the available operating pressure.
- Step 2 - **Determine the series cylinder to use**, based on operating pressure.
- Step 3 - **Turn to the appropriate cylinder selection section.** Select the mounting style that fits your installation needs. Determine the bore and rod sizes available for the model you select. Then complete model selection.
  - Choose a rod end style and the desired rod end accessories.
  - Size the cylinder to meet your application requirements.
- Step 4 - **Consider the following conditions** which may require further modifications to the cylinder you have selected.

Application Condition	Check the Following
Quick Starts or Stops	Confirm that determined thrust is sufficient to accelerate or decelerate cylinder and load within prescribed distance. Mandatory cushions can be used to reduce shock during deceleration, check that peak pressures will be within tolerable limits.
Long Push Stroke	Check whether stop tube (4MAJ with aluminum piston only) is required to prevent excessive bearing loads and wear.
High-column Loading Long Push Stroke	Determine if standard size piston rod is strong enough to accommodate intended load. See Piston Rod Selection Chart or Application Engineering section for recommendations.
Long Horizontal Stroke	Determine if standard size piston rod is strong enough to accommodate intended load.

#### Options and Modifications:

- Piston Bumper Seals
- Piston Bumpers (1/4" Thick)
- Port and Cushion Adjust Relocation
- Port Thread Styles
- Multiple Ports
- Adjustable Sensors
- Linear Position Sensing Option (LPSO)
- Double Rod End
- Rod End Modifications
- Stop Tube
- Mixed Mountings
- Shock Absorber on Cap End
- Round Tube and Tie Rod Construction
- Air Cylinder/Valve Combination (ACVB)
- Hydro-Check for smooth hydraulic control



For a guided version of the 4MAJ Series, please see the HB Series in Section E.

**B**

Tie Rod Pneumatic Cylinders

4MA Series

4MAJ Series

2MNR Series

ACVB Option

LPSO Option

P1D Series

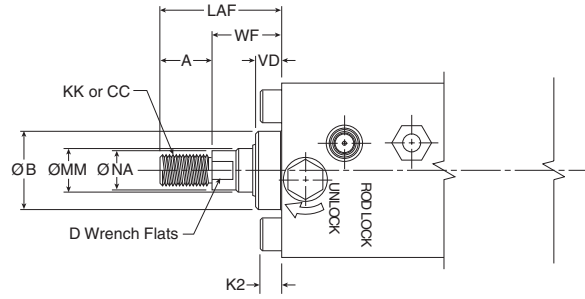
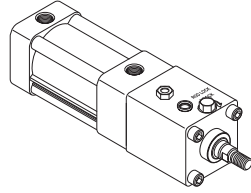
# Style T

# Tie Rod Pneumatic Cylinders 4MAJ Series, Rod Lock Option

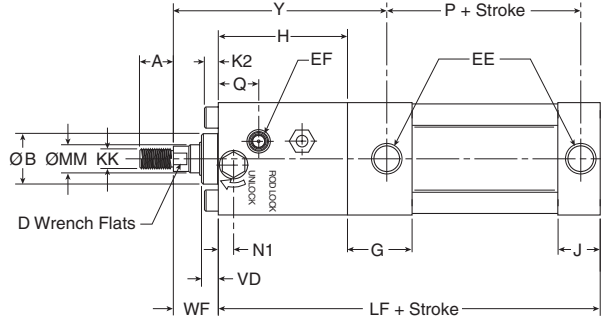
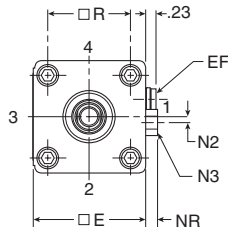
## Single Rod

### No Mount Basic

Style T  
(NFPA MX0)



For dimensions of all standard rod end styles, see next page.



### Style T Dimensions

Bore size	Rod no.	Rod dia. MM	Thread			A	AA	B	D	E	EE (NPTF)	EF (NPTF)	G	H	J
			Style 8 CC	Style 4 & 9 KK	Style 6										
1-1/2	1	5/8	1/2 - 20	7/16 - 20	5/8 - 18	0.750	2.020	1.124	1/2	2.000	3/8	1/8	1.438	2.625	0.938
	3	1	7/8 - 14	3/4 - 16	1 - 14	1.125	2.600	1.499	7/8	2.500	3/8	1/8	1.375	3.875	0.937
2	1	5/8	1/2 - 20	7/16 - 20	5/8 - 18	0.750	3.100	1.124	1/2	3.000	3/8	1/8	1.344	2.875	0.938
	3	1	7/8 - 14	3/4 - 16	1 - 14	1.125	3.100	1.499	7/8	3.000	3/8	1/8	1.344	4.000	0.938
2-1/2	1	5/8	1/2 - 20	7/16 - 20	5/8 - 18	0.750	3.900	1.499	7/8	3.750	1/2	1/4	1.594	4.500	1.125
	3	1-3/8	1-1/4 - 12	1 - 14	1-3/8 - 14	1.625	3.900	1.999	1-1/8	3.750	1/2	1/4	1.594	4.875	1.125
3-1/4	1	1	7/8 - 14	3/4 - 16	1 - 14	1.125	4.700	1.499	7/8	4.500	1/2	1/4	1.594	4.875	1.125
	3	1-3/8	1-1/4 - 12	1 - 14	1-3/8 - 14	1.625	4.700	1.999	1-1/8	4.500	1/2	1/4	1.594	5.125	1.125
4	1	1	7/8 - 14	3/4 - 16	1 - 14	1.125	5.800	1.499	7/8	5.500	1/2	1/4	1.594	5.375	1.219
	3	1-3/8	1-1/4 - 12	1 - 14	1-3/8 - 14	1.625	5.800	1.999	1-1/8	5.500	1/2	1/4	1.594	5.750	1.219
5	1	1	7/8 - 14	3/4 - 16	1 - 14	1.125	5.800	1.499	7/8	5.500	1/2	1/4	1.594	5.375	1.219
	3	1-3/8	1-1/4 - 12	1 - 14	1-3/8 - 14	1.625	5.800	1.999	1-1/8	5.500	1/2	1/4	1.594	5.750	1.219

Bore size	Rod no.	Rod dia. MM	K2	LAF	N1	N2	Hex N3	NA	NR	Q	R	VD	WF	Y	Add stroke	
															LF	P
1-1/2	1	5/8	0.250	1.750	0.220	0.140	5/16	0.563	0.190	0.715	1.430	0.375	1.000	4.500	6.250	2.313
	3	1	0.313	2.500	0.338	0.146	1/2	0.938	0.275	1.065	1.840	0.500	1.375	6.125	7.500	2.313
2	1	5/8	0.313	1.750	0.346	0.150	1/2	0.563	0.265	0.755	2.190	0.500	1.000	4.813	6.625	2.375
	3	1	0.313	2.500	0.346	0.148	1/2	0.938	0.265	1.120	2.190	0.500	1.375	6.313	7.750	2.375
2-1/2	1	5/8	0.313	1.750	0.631	0.180	5/8	0.938	0.340	1.510	2.760	0.500	1.375	6.938	8.750	2.625
	3	1-3/8	0.375	3.250	0.813	0.247	5/8	1.313	0.350	1.645	2.760	0.625	1.625	7.563	9.125	2.625
3-1/4	1	1	0.375	2.500	0.625	0.240	7/8	0.938	0.500	1.725	3.320	0.500	1.375	7.313	9.125	2.625
	3	1-3/8	0.375	3.250	0.771	0.276	7/8	1.313	0.490	1.679	3.320	0.750	1.625	7.813	9.375	2.625
4	1	1	0.500	2.500	0.720	0.220	7/8	0.938	0.500	1.995	4.100	0.500	1.375	7.813	9.875	2.875
	3	1-3/8	0.500	3.250	0.720	0.220	7/8	1.313	0.490	2.330	4.100	0.750	1.625	8.438	10.250	2.875



For inventory, lead times, and kit lookup, visit [www.pdnplu.com](http://www.pdnplu.com)

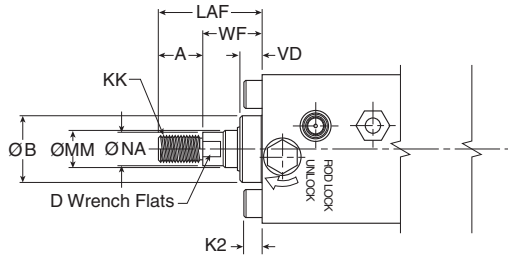


# Rod End Thread Styles

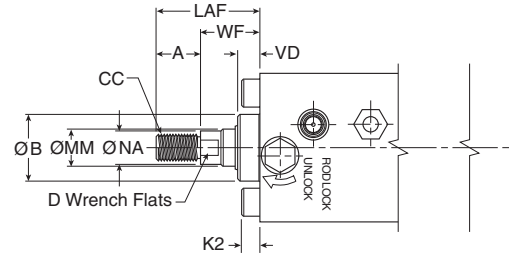
# Tie Rod Pneumatic Cylinders 4MAJ Series, Rod Lock Option

## Rod End

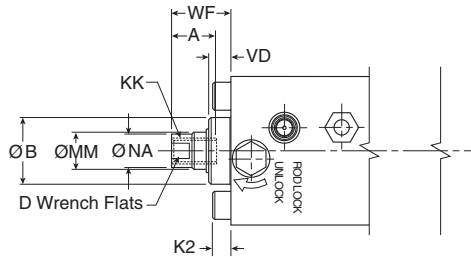
**Thread Style 4**  
(NFPA Style SM)  
Small Male



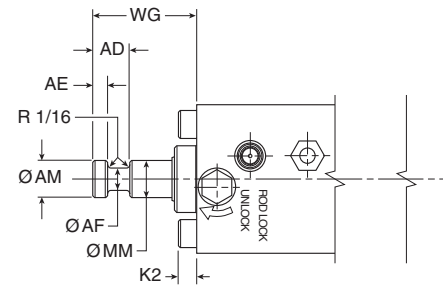
**Thread Style 8**  
(NFPA Style IM)  
Intermediate Male



**Thread Style 9**  
(NFPA Style SF)  
Short Female



**Thread Style 55**  
For use with Split Coupler  
(please reference page B77 for more information)



### Thread Style 3 - "Special Thread"

Special threads, rod extensions, rod eyes, blanks, etc. are also available. To order, specify "Style 3" and give desired dimensions for KK or CC, A and W or WF. If otherwise special, please supply dimensioned sketch.

### Rod End Dimensions

Bore size	Rod no.	Rod dia. MM	Thread		Style 6	A	AD	AE	AF	AM	B	D	K2	LAF	NA	VD	WF	WG
			Style 8 CC	Style 4 & 9 KK														
1-1/2	1	5/8	1/2 - 20	7/16 - 20	5/8 - 18	0.750	0.625	0.250	0.375	0.570	1.124	1/2	0.250	1.750	0.563	0.375	1.000	1.750
	2	5/8	1/2 - 20	7/16 - 20	5/8 - 18	0.750	0.625	0.250	0.375	0.570	1.124	1/2	0.313	1.750	0.563	0.375	1.000	1.750
2	3	1	7/8 - 14	3/4 - 16	1 - 14	1.125	0.938	0.375	0.688	0.950	1.499	7/8	0.313	2.500	0.938	0.500	1.375	2.375
	1	5/8	1/2 - 20	7/16 - 20	5/8 - 18	0.750	0.625	0.250	0.375	0.570	1.124	1/2	0.313	1.750	0.563	0.500	1.000	1.750
2-1/2	3	1	7/8 - 14	3/4 - 16	1 - 14	1.125	0.938	0.375	0.688	0.950	1.499	7/8	0.313	2.500	0.938	0.500	1.375	2.375
	1	5/8	1/2 - 20	7/16 - 20	5/8 - 18	0.750	0.625	0.250	0.375	0.570	1.124	1/2	0.313	1.750	0.563	0.500	1.000	1.750
3-1/4	3	1	7/8 - 14	3/4 - 16	1 - 14	1.125	0.938	0.375	0.688	0.950	1.499	7/8	0.375	2.500	0.938	0.500	1.375	2.375
	3	1-3/8	1-1/4 - 12	1 - 14	1-3/8 - 14	1.625	1.063	0.375	0.875	1.320	1.999	1-1/8	0.375	3.250	1.313	0.625	1.625	2.750
4	1	1	7/8 - 14	3/4 - 16	1 - 14	1.125	0.938	0.375	0.688	0.950	1.499	7/8	0.375	2.500	0.938	0.500	1.375	2.375
	3	1-3/8	1-1/4 - 12	1 - 14	1-3/8 - 14	1.625	1.063	0.375	0.875	1.320	1.999	1-1/8	0.375	3.250	1.313	0.750	1.625	2.750
5	1	1	7/8 - 14	3/4 - 16	1 - 14	1.125	0.938	0.375	0.688	0.950	1.499	7/8	0.500	2.500	0.938	0.500	1.375	2.375
	3	1-3/8	1-1/4 - 12	1 - 14	1-3/8 - 14	1.625	1.063	0.375	0.875	1.320	1.999	1-1/8	0.500	3.250	1.313	0.750	1.625	2.750

B	Tie Rod Pneumatic Cylinders
	4MA Series
	4MAJ Series
	2MNR Series
	ACVB Option
	LPSO Option
	P1D Series



For inventory, lead time, and kit lookup, visit [www.pdnplu.com](http://www.pdnplu.com)

# K-type Cylinder

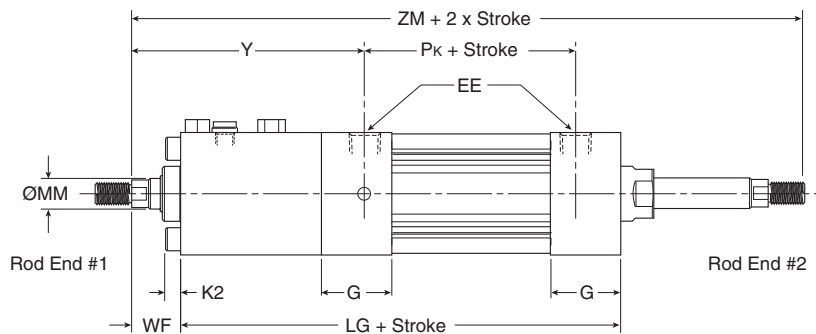
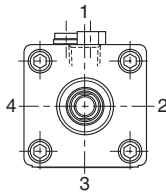
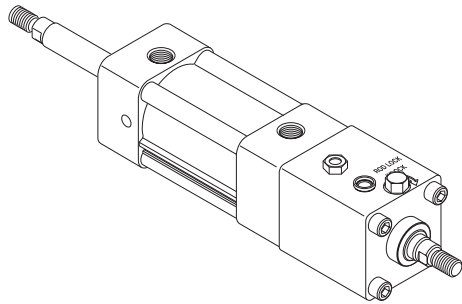
To determine dimensions for a double rod end cylinder, first refer to the desired single rod end mounting style cylinder shown in this catalog section. After selecting the necessary dimensions from that drawing, return to this page and supplement the single rod end dimensions with those shown in the drawings and dimension table below. Note that double rod end cylinders have a head dimension G at both ends,

# Tie Rod Pneumatic Cylinders 4MAJ Series – 1-1/2" to 5" Bore Size

and that LG replaces LF, Pk replaces P, etc. The double rod end dimensions differ from, or are in addition to, those for single rod cylinders.

When a double rod end cylinder has two different rod ends, please clearly state which rod end is to be available at which head end.

## K-type 1-1/2" to 5" Bore Size



Double rod cylinders not available with composite piston type.

Mounting styles for single rod models	Corresponding mounting styles for double rod models
C	KC
CB	KCB
D	KD
DD	KDD
F	KF
G	KG
J	KJ
T	KT
TB	KTB
TD	KTD

## Style KT Dimensions

Bore size	Rod no.	Rod dia. MM	EE (NPTF)	G	K2	WF	Y	Add Stroke								ZM
								LG	Pk	SAk	XAk	SSk	SNk	SEk	XEk	
1-1/2	1	5/8	3/8	1.438	0.250	1.000	4.500	6.750	2.375	8.750	8.750	3.375	2.250	9.000	8.875	8.750
	2	5/8	3/8	1.375	0.313	1.000	4.750	7.000	2.375	9.000	9.000	3.375	2.250	9.625	9.313	9.000
	3	1	3/8	1.375	0.313	1.375	6.125	8.000	2.375	10.000	10.375	3.375	2.250	10.625	10.688	10.750
2-1/2	1	5/8	3/8	1.344	0.313	1.000	4.813	7.125	2.375	9.125	9.125	3.500	2.375	10.000	9.563	9.125
	3	1	3/8	1.344	0.313	1.375	6.313	8.250	2.375	10.250	10.625	3.500	2.375	11.125	11.063	11.000
3-1/4	1	1	1/2	1.594	0.375	1.375	6.938	9.250	2.625	11.750	11.875	3.750	2.625	12.250	12.125	12.000
	3	1-3/8	1/2	1.594	0.375	1.625	7.563	9.625	2.625	12.125	12.500	3.750	2.625	12.625	12.750	12.875
4	1	1	1/2	1.594	0.375	1.375	7.313	9.625	2.625	12.125	12.250	3.750	2.625	12.875	12.625	12.375
	3	1-3/8	1/2	1.594	0.375	1.625	7.813	9.875	2.625	12.375	12.750	3.750	2.625	13.125	13.125	13.125
5	1	1	1/2	1.594	0.500	1.375	7.813	10.313	2.813	13.063	13.063	3.563	2.813	-	-	13.063
	3	1-3/8	1/2	1.594	0.500	1.625	8.438	10.688	2.813	13.438	13.688	3.563	2.813	-	-	13.938
Replaces Dimension								LF	P	SA	XA	SS	SN	SE	XE	-
On Single Rod Mounting Styles								All Styles	All Styles	CB	CB	C	F	G	G	All



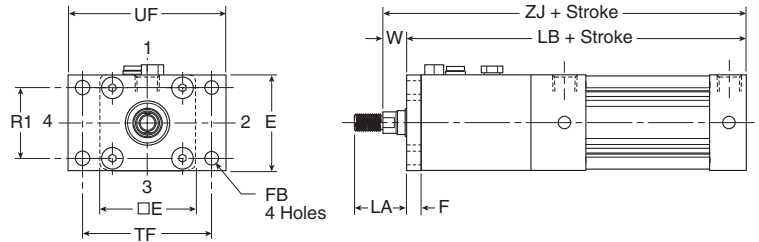
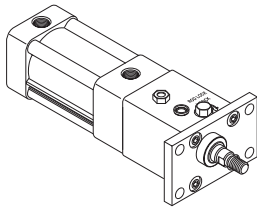
For inventory, lead times, and kit lookup, visit [www.pdnplu.com](http://www.pdnplu.com)

**Style J, H**

**Tie Rod Pneumatic Cylinders  
4MAJ Series – 1-1/2" to 5" Bore Size**

**Head Rectangular Flange**

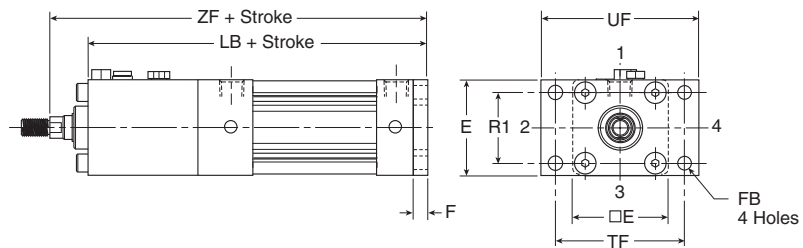
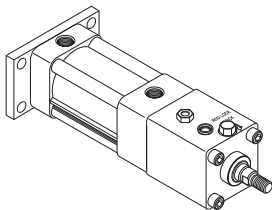
Style J  
(NFPA MF1)



**Note:** Style J has a W dimension instead of WF and a LA dimension instead of LAF because of the flange installation. Please use dimensions W and LA regarding rod ends only for Style J. For reference,  $WF = W + F$  and  $LA = W + A$ .

**Cap Rectangular Flange**

Style H  
(NFPA MF2)



**Styles J and H Dimensions**

Bore size	Rod no.	Rod dia. MM	A	E	F	FB	LA	R1	TF	UF	W	Add stroke		
												LB	ZF	ZJ
1-1/2	1	5/8	0.750	2.000	0.375	0.313	1.375	1.430	2.750	3.375	0.625	6.625	7.625	7.250
	1	5/8	0.750	2.500	0.375	0.375	1.375	1.840	3.375	4.125	0.625	6.875	7.875	7.500
2	3	1	1.125	2.500	0.375	0.375	2.125	1.840	3.375	4.125	1.000	7.875	9.250	8.875
	1	5/8	0.750	3.000	0.375	0.375	1.375	2.190	3.875	4.625	0.625	7.000	8.000	7.625
2-1/2	3	1	1.125	3.000	0.375	0.375	2.125	2.190	3.875	4.625	1.000	8.125	9.500	9.125
	1	5/8	0.750	3.750	0.625	0.438	1.875	2.760	4.688	5.500	0.750	9.375	10.750	10.125
3-1/4	3	1-3/8	1.625	3.750	0.625	0.438	2.625	2.760	4.688	5.500	1.000	9.750	11.375	10.750
	1	1	1.125	4.500	0.625	0.438	1.875	3.320	5.438	6.250	0.750	9.750	11.125	10.500
4	3	1-3/8	1.625	4.500	0.625	0.438	2.625	3.320	5.438	6.250	1.000	10.000	11.625	11.000
	1	1	1.125	5.500	0.625	0.563	1.875	4.100	6.625	7.625	0.750	10.500	11.875	11.250
5	3	1-3/8	1.625	5.500	0.625	0.563	2.625	4.100	6.625	7.625	1.000	10.875	12.500	11.875

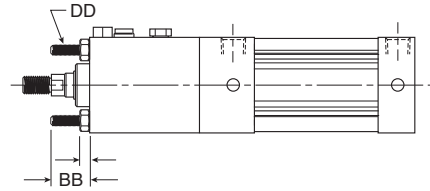
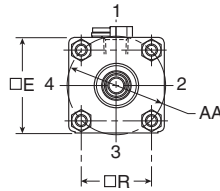
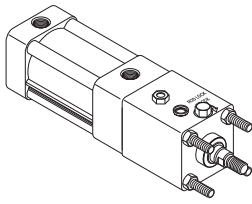
**B**  
Tie Rod Pneumatic Cylinders  
4MA Series  
4MAJ Series  
2MNR Series  
ACVB Option  
LPSO Option  
PID Series



For inventory, lead time, and kit lookup, visit [www.pdnplu.com](http://www.pdnplu.com)

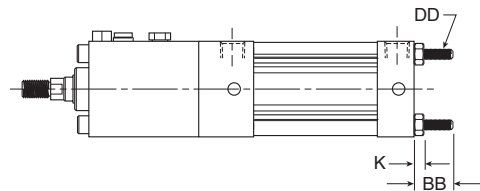
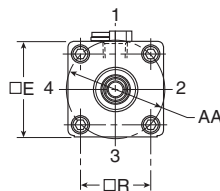
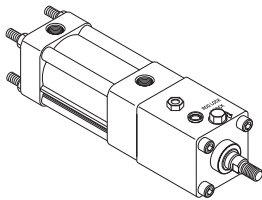
**Tie Rods Extended Head End Mount**

Style TB  
 (NFPA MX3)



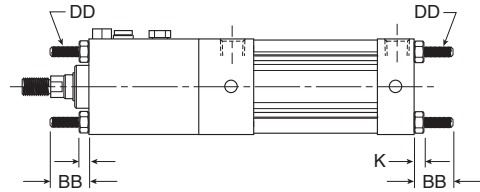
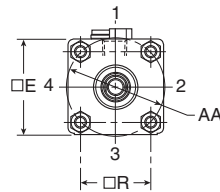
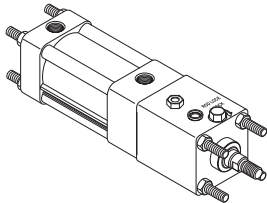
**Tie Rods Extended Cap End Mount**

Style TC  
 (NFPA MX2)



**Tie Rods Extended Both Ends Mount**

Style TD  
 (NFPA MX1)



**Styles TB, TC and TD Dimensions**

Bore size	Rod no.	Rod dia. MM	AA	BB	DD	E	K	R
1-1/2	1	5/8	2.020	1.000	1/4 - 28	2.000	0.250	1.430
	3	1	2.600	1.125	5/16 - 24	2.500	0.313	1.840
2	1	5/8	2.600	1.125	5/16 - 24	2.500	0.313	1.840
	3	1	3.100	1.125	5/16 - 24	3.000	0.313	2.190
2-1/2	1	5/8	3.100	1.125	5/16 - 24	3.000	0.313	2.190
	3	1	3.900	1.375	3/8 - 24	3.750	0.375	2.760
3-1/4	1	1	3.900	1.375	3/8 - 24	3.750	0.375	2.760
	3	1-3/8	4.700	1.375	3/8 - 24	4.500	0.375	3.320
4	1	1	4.700	1.375	3/8 - 24	4.500	0.375	3.320
	3	1-3/8	5.800	1.813	1/2 - 20	5.500	0.438	4.100
5	1	1	5.800	1.813	1/2 - 20	5.500	0.438	4.100
	3	1-3/8	5.800	1.813	1/2 - 20	5.500	0.438	4.100

**B**  
 Tie Rod Pneumatic Cylinders  
 4MA Series  
 4MAJ Series  
 2MNR Series  
 ACVB Option  
 LPSO Option  
 P1D Series



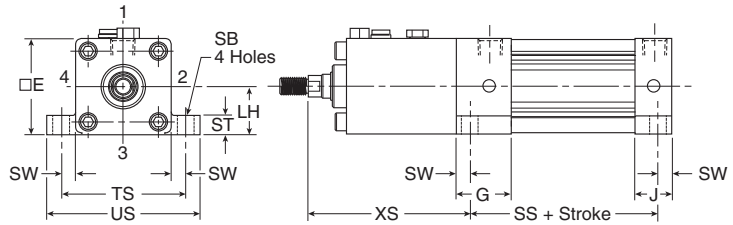
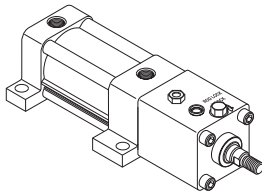
For inventory, lead times, and kit lookup, visit [www.pdnplu.com](http://www.pdnplu.com)

**Style C, F**

**Tie Rod Pneumatic Cylinders  
4MAJ Series – 1-1/2" to 5" Bore Size**

**Side Lug Mount**

Style C  
(NFPA MS2)

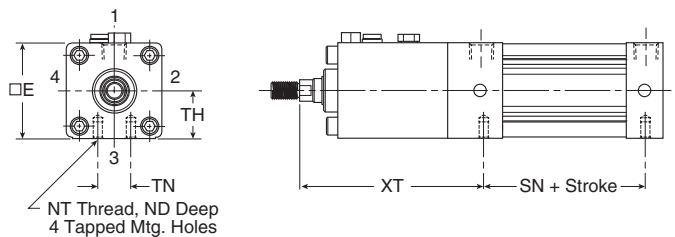
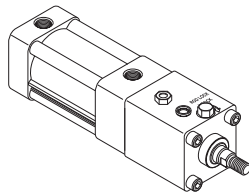


**Style C Dimensions**

Bore size	Rod no.	Rod dia. MM	E	G	J	+/-0.003 LH	SB	ST	SW	TS	US	XS	Add stroke SS
1-1/2	1	5/8	2.000	1.438	0.938	0.993	0.438	0.500	0.375	2.750	3.500	4.000	2.875
	3	1	2.500	1.375	0.937	1.243	0.438	0.500	0.375	3.250	4.000	5.625	2.875
2	1	5/8	2.500	1.375	0.937	1.243	0.438	0.500	0.375	3.250	4.000	4.250	2.875
	3	1	2.500	1.375	0.937	1.243	0.438	0.500	0.375	3.250	4.000	5.625	2.875
2-1/2	1	5/8	3.000	1.344	0.938	1.493	0.438	0.500	0.375	3.750	4.500	4.250	3.000
	3	1	3.000	1.344	0.938	1.493	0.438	0.500	0.375	3.750	4.500	5.750	3.000
3-1/4	1	1	3.750	1.594	1.125	1.868	0.563	0.750	0.500	4.750	5.750	6.375	3.250
	3	1-3/8	3.750	1.594	1.125	1.868	0.563	0.750	0.500	4.750	5.750	7.000	3.250
4	1	1	4.500	1.594	1.125	2.243	0.563	0.750	0.500	5.500	6.500	6.750	3.250
	3	1-3/8	4.500	1.594	1.125	2.243	0.563	0.750	0.500	5.500	6.500	7.250	3.250
5	1	1	5.500	1.594	1.219	2.743	0.813	1.000	0.688	6.875	8.250	7.438	3.125
	3	1-3/8	5.500	1.594	1.219	2.743	0.813	1.000	0.688	6.875	8.250	8.063	3.125

**Side Tap Mount**

Style F  
(NFPA MS4)



**Style F Dimensions**

Bore size	Rod no.	Rod dia. MM	E	ND	NT	+/-0.003 TH	TN	XT	Add stroke SN
1-1/2	1	5/8	2.000	0.375	1/4 - 20	0.993	0.625	4.563	2.250
	3	1	2.500	0.375	5/16 - 18	1.243	0.875	6.188	2.250
2	1	5/8	2.500	0.438	5/16 - 18	1.243	0.875	4.813	2.250
	3	1	2.500	0.375	5/16 - 18	1.243	0.875	6.188	2.250
2-1/2	1	5/8	3.000	0.625	3/8 - 16	1.493	1.250	4.813	2.375
	3	1	3.000	0.625	3/8 - 16	1.493	1.250	6.313	2.375
3-1/4	1	1	3.750	0.750	1/2 - 13	1.868	1.500	6.938	2.625
	3	1-3/8	3.750	0.750	1/2 - 13	1.868	1.500	7.563	2.625
4	1	1	4.500	0.750	1/2 - 13	2.243	2.063	7.313	2.625
	3	1-3/8	4.500	0.750	1/2 - 13	2.243	2.063	7.813	2.625
5	1	1	5.500	0.938	5/8 - 11	2.743	2.688	7.813	2.875
	3	1-3/8	5.500	0.938	5/8 - 11	2.743	2.688	8.438	2.875

**B**

Tie Rod Pneumatic Cylinders

4MA Series

4MAJ Series

2MNR Series

ACVB Option

LPSO Option

P1D Series



For inventory, lead time, and kit lookup, visit [www.pdnplu.com](http://www.pdnplu.com)

B49

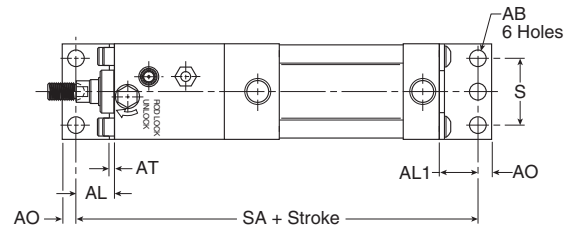
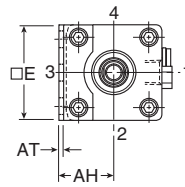
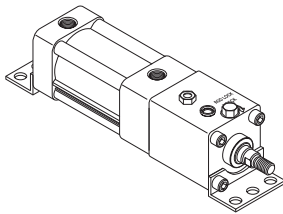
**Parker Hannifin Corporation**  
Pneumatic Division  
Richland, Michigan  
[www.parker.com/pneumatics](http://www.parker.com/pneumatics)

**Style CB, G**

**Tie Rod Pneumatic Cylinders  
4MAJ Series – 1-1/2" to 5" Bore Size**

**Side End Angle Mount**

Style CB  
(NFFPA MS1)

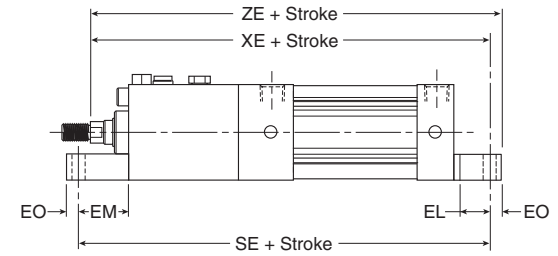
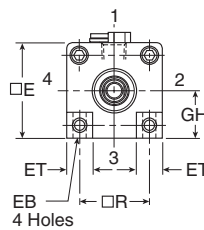
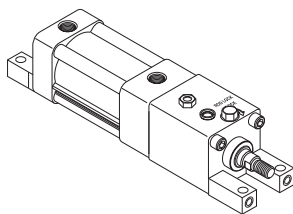


**Style CB Dimensions**

Bore size	Rod no.	Rod dia. MM	AB	AH	AL	AL1	AO	AT	E	S	Add stroke	
											SA	SA
1-1/2	1	5/8	0.438	1.188	1.000	1.000	0.375	0.125	2.000	1.250	8.250	
	3	1	0.438	1.438	1.000	1.000	0.375	0.125	2.500	1.750	8.500	
2	1	5/8	0.438	1.625	1.000	1.000	0.375	0.125	3.000	2.250	8.625	
	3	1	0.438	1.625	1.000	1.000	0.375	0.125	3.000	2.250	9.750	
2-1/2	1	5/8	0.563	1.938	1.250	1.250	0.500	0.125	3.750	2.750	11.250	
	3	1-3/8	0.563	1.938	1.250	1.250	0.500	0.125	3.750	2.750	11.625	
3-1/4	1	1	0.563	2.250	1.875	1.250	0.500	0.125	4.500	3.500	12.250	
	3	1-3/8	0.563	2.250	1.875	1.250	0.500	0.125	4.500	3.500	12.500	
4	1	1	0.688	2.750	1.375	1.375	0.625	0.188	5.500	4.250	12.625	
	3	1-3/8	0.688	2.750	1.375	1.375	0.625	0.188	5.500	4.250	13.000	

**Side End Lug Mount**

Style G  
(NFFPA MS7)



**Style G Dimensions**

Bore size	Rod no.	Rod dia. MM	E	EB	EL	EM	EO	ET	+/- .003 GH R	Add stroke			
										SE	XE	ZE	
1-1/2	1	5/8	2.000	0.281	0.750	1.125	0.250	0.563	0.993	1.430	8.125	8.000	8.250
	3	1	2.500	0.344	0.938	1.313	0.313	0.688	1.243	1.840	8.750	8.438	8.750
2	1	5/8	3.000	0.344	1.063	1.438	0.313	0.813	1.493	2.190	9.125	8.688	9.000
	3	1	3.000	0.344	1.063	1.438	0.313	0.813	1.493	2.190	10.250	10.188	10.500
2-1/2	1	5/8	3.750	0.406	0.875	1.500	0.375	1.000	1.868	2.760	11.125	11.000	11.375
	3	1-3/8	3.750	0.406	0.875	1.500	0.375	1.000	1.868	2.760	11.500	11.625	12.000
3-1/4	1	1	4.500	0.406	1.000	1.625	0.375	1.188	2.243	3.320	11.750	11.500	11.875
	3	1-3/8	4.500	0.406	1.000	1.625	0.375	1.188	2.243	3.320	12.000	12.000	12.375



For inventory, lead times, and kit lookup, visit [www.pdnplu.com](http://www.pdnplu.com)

B50

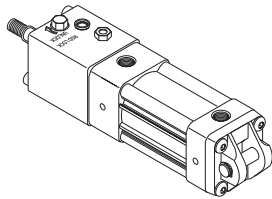
**Parker Hannifin Corporation**  
Pneumatic Division  
Richland, Michigan  
[www.parker.com/pneumatics](http://www.parker.com/pneumatics)

**Style BB, BC**

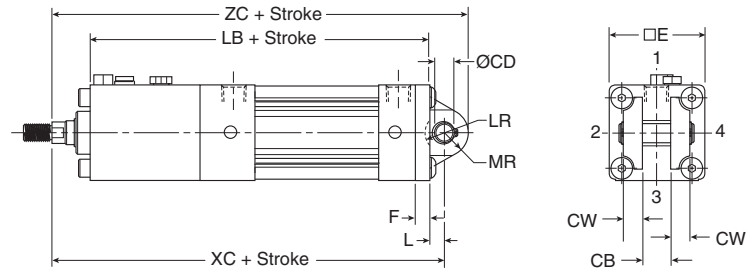
**Tie Rod Pneumatic Cylinders  
4MAJ Series – 1-1/2" to 5" Bore Size**

**Cap Fixed Clevis Mount**

Style BB  
(NFPA MP1)

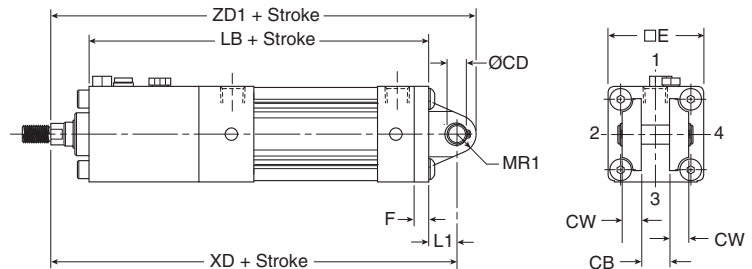
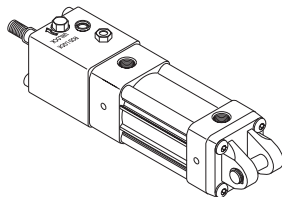


**NOTE:** For maximum swivel angle of BB mount with rear mounting plate, please reference cylinder accessories on page B80.



**Cap Detachable Clevis Mount**

Style BC  
(NFPA MP2)



**Styles BB and BC Dimensions**

Bore size	Rod no.	Rod dia. MM	CB	+0.000 -0.002 CD	CW	E	F	L	L1	LR	MR	MR1	Add stroke				
													LB	XC	XD	ZC	ZD1
1-1/2	1	5/8	0.750	0.501	0.500	2.000	0.375	0.375	0.750	0.750	0.625	0.500	6.625	8.000	8.375	8.625	8.875
	2	1	0.750	0.501	0.500	2.500	0.375	0.375	0.750	0.750	0.625	0.500	6.875	8.250	8.625	8.875	9.125
2	3	1	0.750	0.501	0.500	2.500	0.375	0.375	0.750	0.750	0.625	0.500	7.875	9.625	10.000	10.250	10.500
	1	5/8	0.750	0.501	0.500	3.000	0.375	0.375	0.750	0.750	0.625	0.500	7.000	8.375	8.750	9.000	9.250
2-1/2	3	1	0.750	0.501	0.500	3.000	0.375	0.375	0.750	0.750	0.625	0.500	8.125	9.875	10.250	10.500	10.750
	1	5/8	1.250	0.751	0.625	3.750	0.625	0.625	1.250	1.000	0.938	0.750	9.375	11.375	12.000	12.313	12.750
3-1/4	3	1-3/8	1.250	0.751	0.625	3.750	0.625	0.625	1.250	1.000	0.938	0.750	9.750	12.000	12.625	12.938	13.375
	1	1	1.250	0.751	0.625	4.500	0.625	0.625	1.250	1.000	0.938	0.750	9.750	11.750	12.375	12.688	13.125
4	3	1-3/8	1.250	0.751	0.625	4.500	0.625	0.625	1.250	1.000	0.938	0.750	10.000	12.250	12.875	13.188	13.625
	1	1	1.250	0.751	0.625	5.500	0.625	0.625	1.250	1.000	0.938	0.750	10.500	12.500	13.125	13.438	13.875
5	3	1-3/8	1.250	0.751	0.625	5.500	0.625	0.625	1.250	1.000	0.938	0.750	10.875	13.125	13.750	14.063	14.500

B	Tie Rod Pneumatic Cylinders
	4MA Series
4MAJ Series	
2MNR Series	
ACVB Option	
LPSO Option	
P1D Series	



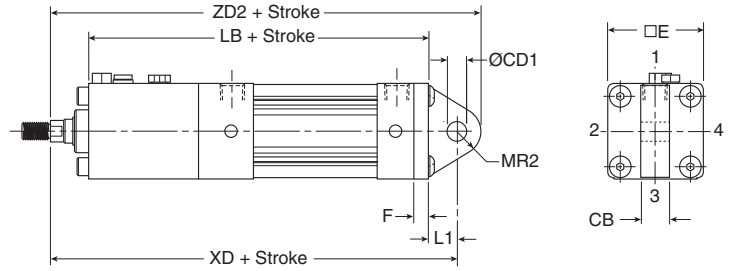
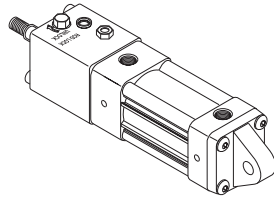
For inventory, lead time, and kit lookup, visit [www.pdnplu.com](http://www.pdnplu.com)

**Style BE, DD**

**Tie Rod Pneumatic Cylinders  
4MAJ Series – 1-1/2" to 5" Bore Size**

**Cap Detachable Eye Mount**

Style BE  
(NFPA MP4)

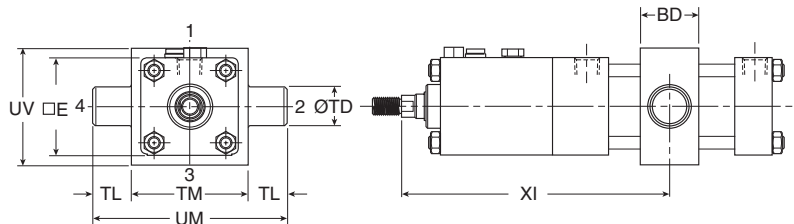
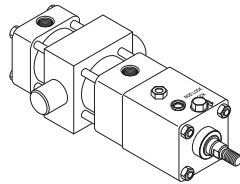


**Style BE Dimensions**

Bore size	Rod no.	Rod dia. MM	CB	+0.02 +0.04 CD1	E	F	L1	MR2	Add Stroke		
									LB	XD	ZD2
1-1/2	1	5/8	0.750	0.500	2.000	0.375	0.750	0.625	6.625	8.375	9.000
	3	1	0.750	0.500	2.500	0.375	0.750	0.625	7.875	10.000	10.625
2	1	5/8	0.750	0.500	2.500	0.375	0.750	0.625	6.875	8.625	9.250
	3	1	0.750	0.500	2.500	0.375	0.750	0.625	7.875	10.000	10.625
2-1/2	1	5/8	0.750	0.500	3.000	0.375	0.750	0.688	7.000	8.750	9.438
	3	1	0.750	0.500	3.000	0.375	0.750	0.688	8.125	10.250	10.938
3-1/4	1	1	1.250	0.750	3.750	0.625	1.250	0.875	9.375	12.000	12.875
	3	1-3/8	1.250	0.750	3.750	0.625	1.250	0.875	9.750	12.625	13.500
4	1	1	1.250	0.750	4.500	0.625	1.250	0.875	9.750	12.375	13.250
	3	1-3/8	1.250	0.750	4.500	0.625	1.250	0.875	10.000	12.875	13.750
5*	1	1	1.250	0.750	5.500	0.625	1.250	0.875	10.500	13.125	14.000
	3	1-3/8	1.250	0.750	5.500	0.625	1.250	0.875	10.875	13.750	14.625

**Intermediate Trunnion Mount**

Style DD  
(NFPA MT4)



**Note:** Tie rod nuts for Style DD have a slot instead of external hex.

**Note:** Style DD requires minimum stroke per table.

**Style DD Dimensions**

Bore size	Rod no.	Rod dia. MM	E	BD	+0.00 -0.001 TD	TL	TM	UM	UV	Min. XI	Min. stroke
2	1	5/8	2.500	1.500	1.000	1.000	3.000	5.000	3.000	6.00	4.000
	3	1	2.500	1.500	1.000	1.000	3.000	5.000	3.000	7.38	4.000
2-1/2	1	5/8	3.000	1.500	1.000	1.000	3.500	5.500	3.500	5.97	3.875
	3	1	3.000	1.500	1.000	1.000	3.500	5.500	3.500	7.47	3.875
3-1/4	1	1	3.750	2.000	1.000	1.000	4.500	6.500	4.250	13.72	4.375
	3	1-3/8	3.750	2.000	1.000	1.000	4.500	6.500	4.250	14.34	4.375
4	1	1	4.500	2.000	1.000	1.000	5.250	7.250	5.000	14.09	4.875
	3	1-3/8	4.500	2.000	1.000	1.000	5.250	7.250	5.000	14.59	4.875
5	1	1	5.500	2.000	1.000	1.000	6.250	8.250	6.000	16.34	5.125
	3	1-3/8	5.500	2.000	1.000	1.000	6.250	8.250	6.000	16.97	5.125



For inventory, lead times, and kit lookup, visit [www.pdnplu.com](http://www.pdnplu.com)

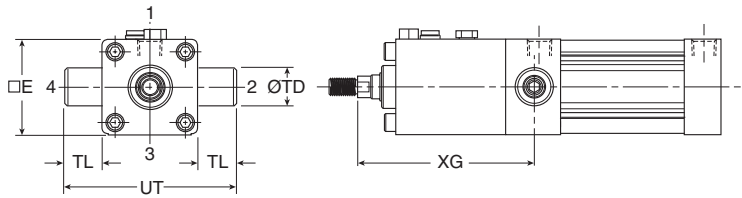
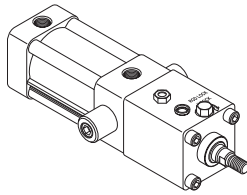


**Style D, DB**

**Tie Rod Pneumatic Cylinders  
4MAJ Series – 1-1/2" to 5" Bore Size**

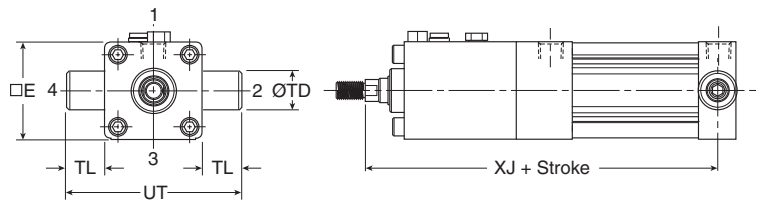
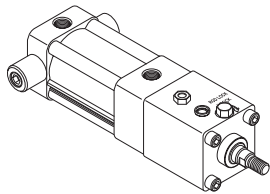
**Head Trunnion Mount**

Style D  
(NFPA MT1)



**Cap Trunnion Mount**

Style DB  
(NFPA MT2)



**Styles D and DB Dimensions**

Bore size	Rod no.	Rod dia. MM	E	+0.000 -0.001		UT	XG	XJ
				TD	TL			
1-1/2	1	5/8	2.000	1.000	1.000	4.000	4.375	6.750
	3	1	2.500	1.000	1.000	4.500	4.625	7.000
2	1	5/8	2.500	1.000	1.000	4.500	4.625	7.125
	3	1	3.000	1.000	1.000	5.000	6.125	8.625
2-1/2	1	5/8	3.000	1.000	1.000	5.000	6.750	9.500
	3	1	3.750	1.000	1.000	5.750	7.375	10.125
3-1/4	1	1	4.500	1.000	1.000	6.500	7.125	9.875
	3	1-3/8	4.500	1.000	1.000	6.500	7.625	10.375
4	1	1	5.500	1.000	1.000	7.500	7.625	10.625
	3	1-3/8	5.500	1.000	1.000	7.500	8.250	11.250

**B**  
Tie Rod Pneumatic Cylinders  
4MA Series  
4MAJ Series  
2MNR Series  
ACVB Option  
LPSO Option  
P1D Series



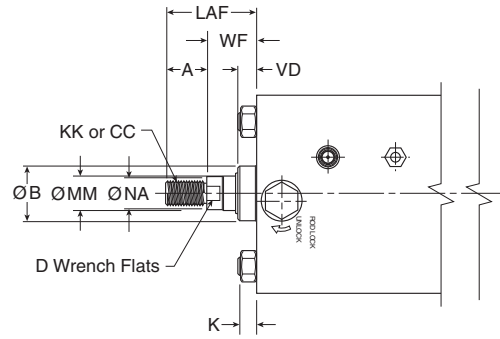
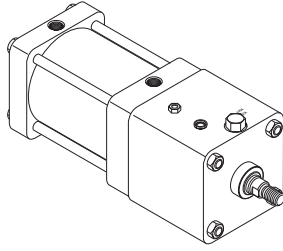
For inventory, lead time, and kit lookup, visit [www.pdnplu.com](http://www.pdnplu.com)

**Style T**

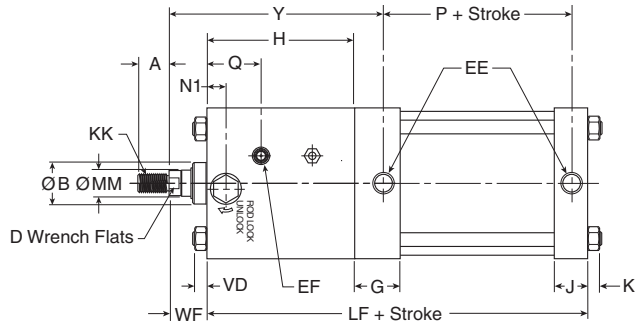
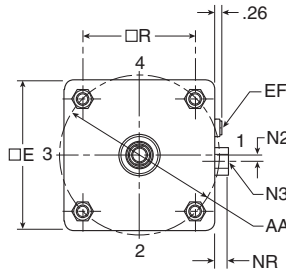
**Tie Rod Pneumatic Cylinders  
4MAJ Series – 6" to 8" Bore Sizes**

**No Mount**

Style T  
(NFPA MX0)



For dimensions of all standard rod end styles, see next page.



**Style T Dimensions**

Bore size	Rod no.	Rod dia. MM	Thread		Style 6	A	AA	B	D	E	EE (NPTF)	EF (NPTF)	G	H	J
			Style 8 CC	Style 4 & 9 KK											
6	1	1-3/8	1-1/4 - 12	1 - 14	1-3/8 - 14	1.625	6.900	1.999	1-1/8	6.500	3/4	1/4	1.910	6.375	1.410
	3	1-3/4	1-1/2 - 12	1-1/4 - 12	1-3/4 - 12	2.000	6.900	2.374	1-1/2	6.500	3/4	1/4	1.910	6.875	1.410
8	1	1-3/8	1-1/4 - 12	1 - 4	1-3/8 - 14	1.625	9.100	1.999	1-1/8	8.500	3/4	1/4	1.810	6.625	1.440
	3	1-3/4	1-1/2 - 12	1-1/4 - 12	1-3/4 - 12	2.000	9.100	2.374	1-1/2	8.500	3/4	1/4	1.810	7.125	1.440

Bore size	Rod no.	Rod dia. MM	Add stroke													
			K	LAF	N1	N2	Hex N3	NA	NR	Q	R	VD	WF	Y	LF	P
6	1	1-3/8	0.438	3.250	1.165	0.177	1-5/16	1.313	0.750	2.705	4.880	0.755	1.625	9.188	11.375	3.125
	3	1-3/4	0.438	3.875	1.495	0.177	1-5/16	1.688	0.740	3.055	4.880	0.875	1.875	9.938	11.875	3.125
8	1	1-3/8	0.563	3.250	1.305	0.177	1-5/16	1.313	0.740	2.885	6.440	0.755	1.625	9.375	11.750	3.250
	3	1-3/4	0.563	3.875	1.570	0.177	1-5/16	1.688	0.740	3.145	6.440	0.875	1.875	10.125	12.250	3.250



For inventory, lead times, and kit lookup, visit [www.pdnplu.com](http://www.pdnplu.com)

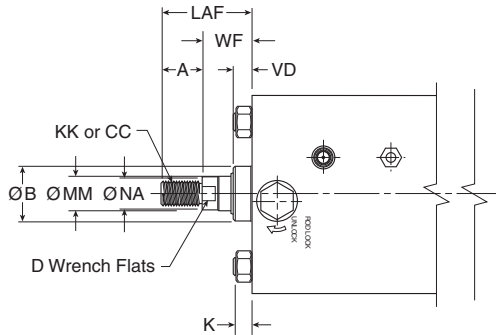
## Rod End Thread Styles

## Tie Rod Pneumatic Cylinders 4MAJ Series – 6" to 8" Bore Sizes

### Rod End

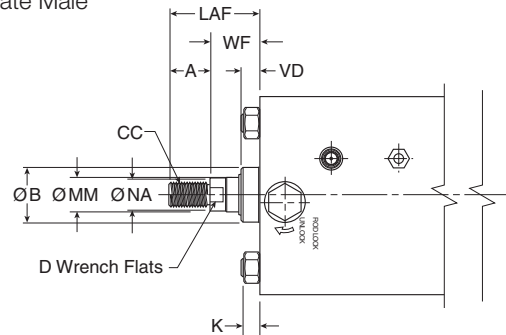
#### Thread Style 4

(NFPA Style SM)  
Small Male



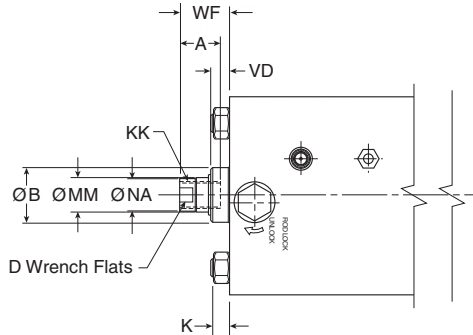
#### Thread Style 8

(NFPA Style IM)  
Intermediate Male



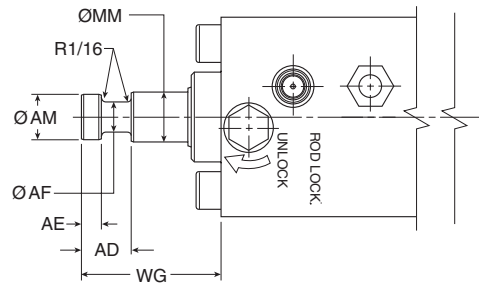
#### Thread Style 9

(NFPA Style SF)  
Short Female



#### Thread Style 55

For use with Split Coupler  
(please reference page B77 for more information)



#### Thread Style 3 - "Special Thread"

Special threads, rod extensions, rod eyes, blanks, etc. are also available.  
To order, specify "Style 3" and give desired dimensions for KK or CC, A and W or WF.  
If otherwise special, please supply dimensioned sketch.

### Rod End Dimensions

Bore size	Rod no.	Rod dia. MM	Thread		Style 6	A	AD	AE	AF	AM	B	D	K	LAF	NA	VD	WF	WG
			Style 8 CC	Style 4 & 9 KK														
6	1	1-3/8	1-1/4 - 12	1 - 14	1-3/8 - 14	1.625	1.063	0.375	0.875	1.320	1.999	1-1/8	0.438	3.250	1.313	0.755	1.625	2.750
	3	1-3/4	1-1/2 - 12	1-1/4 - 12	1-3/4 - 12	2.000	1.313	0.500	1.125	1.700	2.374	1-1/2	0.438	3.875	1.688	0.875	1.875	3.125
8	1	1-3/8	1-1/4 - 12	1 - 14	1-3/8 - 14	1.625	1.063	0.375	0.875	1.320	1.999	1-1/8	0.563	3.250	1.313	0.755	1.625	2.750
	3	1-3/4	1-1/2 - 12	1-1/4 - 12	1-3/4 - 12	2.000	1.313	0.500	1.125	1.700	2.374	1-1/2	0.563	3.875	1.688	0.875	1.875	3.125

**B**

Tie Rod Pneumatic Cylinders

4MA Series

4MAJ Series

2MNR Series

ACVB Option

LPSO Option

P1D Series



For inventory, lead time, and kit lookup, visit [www.pdnplu.com](http://www.pdnplu.com)

B55

**Parker Hannifin Corporation**  
Pneumatic Division  
Richland, Michigan  
[www.parker.com/pneumatics](http://www.parker.com/pneumatics)

## K-type Cylinder

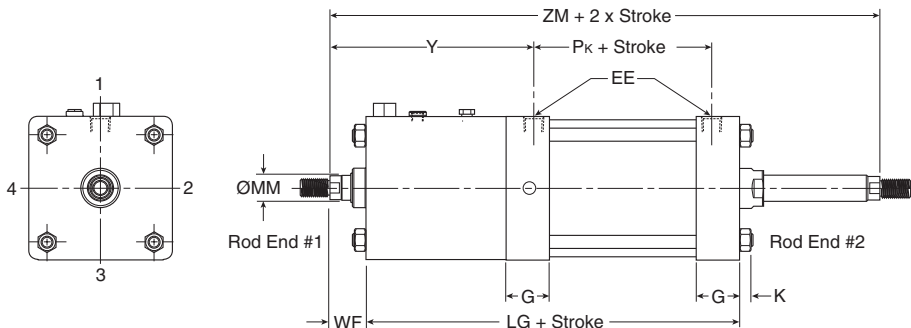
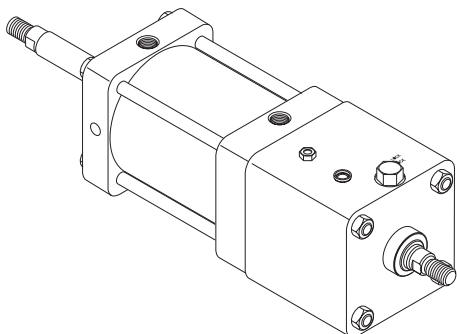
To determine dimensions for a double rod end cylinder, first refer to the desired single rod end mounting style cylinder shown in this catalog section. After selecting the necessary dimensions from that drawing, return to this page and supplement the single rod end dimensions with those shown in the drawings and dimension table below. Note that double rod end cylinders have a head dimension G at both ends, and

## Tie Rod Pneumatic Cylinders 4MAJ Series – 6" to 8" Bore Sizes

that LG replaces LF, PK replaces P, etc. The double rod end dimensions differ from, or are in addition to, those for single rod cylinders.

When a double rod end cylinder has two different rod ends, please clearly state which rod end is to be available at which head end.

### K-type 6" to 8" Bore Size



Mounting styles for single rod models	Corresponding mounting styles for double rod models
C	KC
CB	KCB
D	KD
DD	KDD
F	KF
J	KJ
T	KT
TB	KTB
TD	KTD

### Style KT Dimensions

Bore size	Rod no.	Rod dia. MM	EE (NPTF) G	K	WF	Y	Add Stroke						Add 2X Stroke ZM	
							LG	Pk	SAk	XAk	SSk	SNk		
6	1	1-3/8	3/4	1.910	0.438	1.625	9.188	11.875	3.125	14.625	14.875	4.125	3.125	15.125
	3	1-3/4	3/4	1.910	0.438	1.875	9.938	12.375	3.125	15.125	15.625	4.125	3.125	16.125
8	1	1-3/8	3/4	1.810	0.563	1.625	9.375	12.125	3.250	15.750	15.563	4.125	3.125	15.375
	3	1-3/4	3/4	1.810	0.563	1.875	10.125	12.625	3.250	16.250	16.313	4.125	3.125	16.375
Replaces Dimension On							LF	P	SA	XA	SS	SN	-	
Single Rod Mounting Styles							All Styles	All Styles	CB	CB	C	F	All	

B	Tie Rod Pneumatic Cylinders
	Series
4MA Series	4MAJ Series
2MNR Series	ACVB Option
LPSO Option	P1D Series



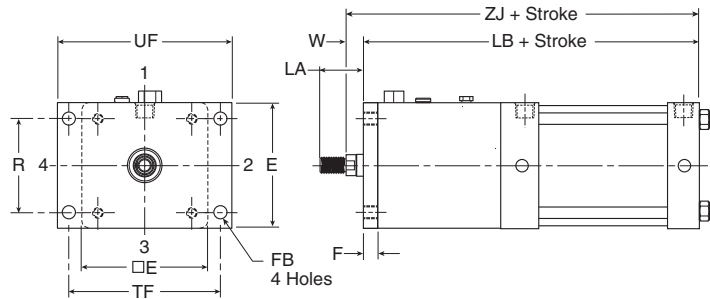
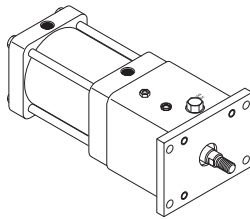
For inventory, lead times, and kit lookup, visit [www.pdnplu.com](http://www.pdnplu.com)

# Style J, H

# Tie Rod Pneumatic Cylinders 4MAJ Series – 6" to 8" Bore Sizes

## Head Rectangular Flange Mount

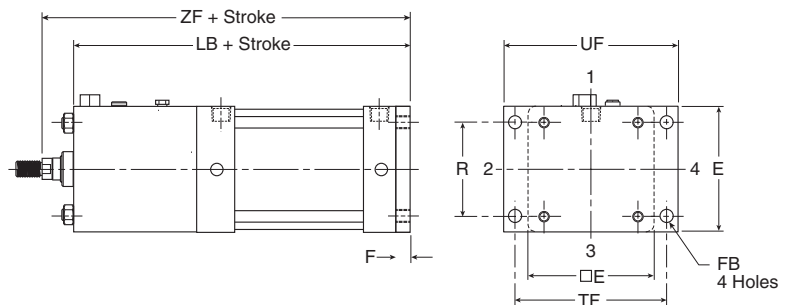
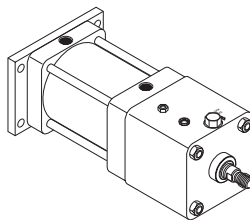
Style J  
(NFPA MF1)  
(only 6" Bore)



**Note:** Style J has a W dimension instead of WF and a LA dimension instead of LAF because of the flange installation. Please use dimensions W and LA regarding rod ends only for Style J.  
For reference,  $WF = W + F$  and  $LA = W + A$ .

## Cap Rectangular Flange Mount

Style H  
(NFPA MF2)  
(only 6" Bore)



## Styles J and H Dimensions

Bore size	Rod no.	Rod dia. MM	Add stroke											
			A	E	F	FB	LA	R	TF	UF	W	LB	ZF	ZJ
6	1	1-3/8	1.625	6.500	0.750	0.563	2.500	4.880	7.625	8.625	0.875	12.125	13.750	13.000
	3	1-3/4	2.000	6.500	0.750	0.563	3.125	4.880	7.625	8.625	1.125	12.625	14.500	13.750

**B**

Tie Rod Pneumatic Cylinders

4MA Series

4MAJ Series

2MNR Series

ACVB Option

LPSO Option

P1D Series



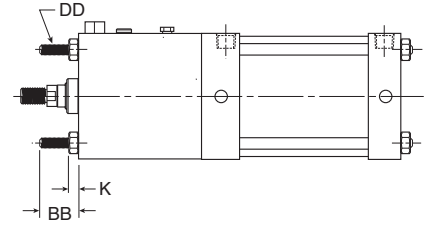
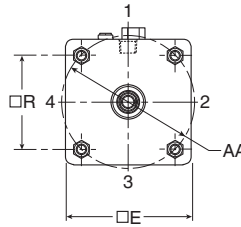
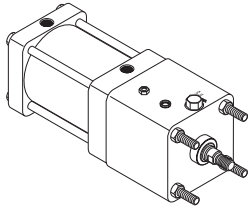
For inventory, lead time, and kit lookup, visit [www.pdnplu.com](http://www.pdnplu.com)

B57

**Parker Hannifin Corporation**  
Pneumatic Division  
Richland, Michigan  
[www.parker.com/pneumatics](http://www.parker.com/pneumatics)

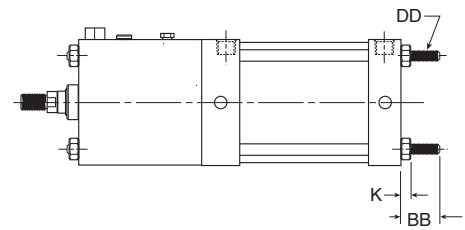
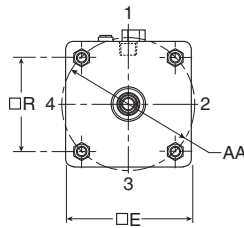
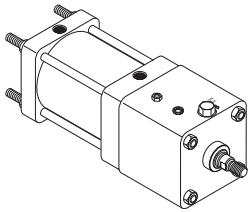
**Tie Rods Extended Head End Mount**

Style TB  
 (NFPA MX3)



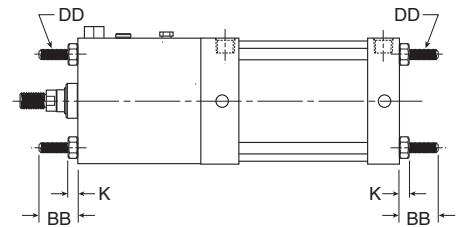
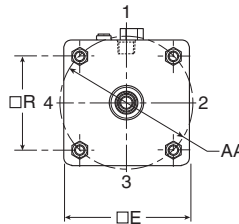
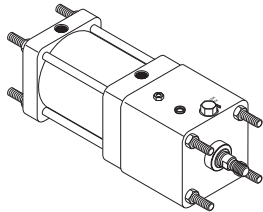
**Tie Rods Extended Cap End Mount**

Style TC  
 (NFPA MX2)



**Tie Rods Extended Both Ends Mount**

Style TD  
 (NFPA MX1)



**Styles TB, TC and TD Dimensions**

Bore size	Rod no.	Rod dia. MM	AA	BB	DD	E	K	R
6	1	1-3/8	6.900	1.813	1/2-20	6.500	0.438	4.880
	3	1-3/4	6.900	1.813	1/2-20	6.500	0.438	4.880
8	1	1-3/8	9.100	2.313	5/8-18	8.500	0.563	6.440
	3	1-3/4	9.100	2.313	5/8-18	8.500	0.563	6.440

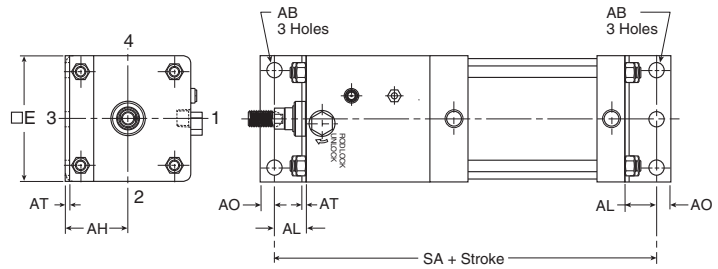
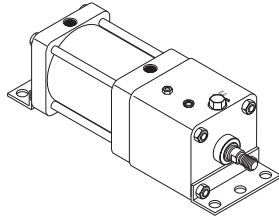
**B**  
 Tie Rod Pneumatic Cylinders  
 4MA Series  
 4MAJ Series  
 2MNR Series  
 ACVB Option  
 LPSO Option  
 P1D Series



For inventory, lead times, and kit lookup, visit [www.pdnplu.com](http://www.pdnplu.com)

**Side End Angle Mount**

Style CB  
 (NFPA MS1)

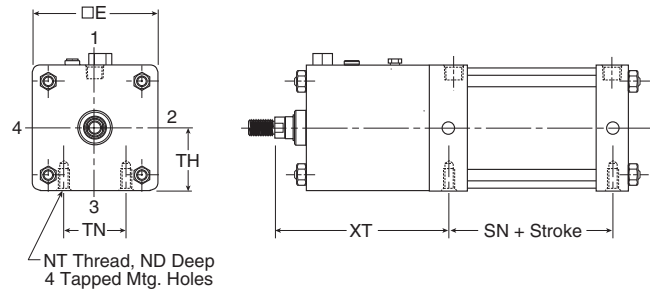
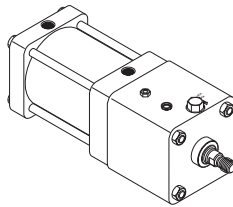


**Style CB Dimensions**

Bore size	Rod no.	Rod dia. MM	AB	AH	AL	AO	AT	E	S	Add stroke SA
6	1	1-3/8	0.813	3.250	1.375	0.625	0.188	6.500	5.250	14.125
	3	1-3/4	0.813	3.250	1.375	0.625	0.188	6.500	5.250	14.625
8	1	1-3/8	0.813	4.250	1.813	0.688	0.250	8.500	7.125	15.375
	3	1-3/4	0.813	4.250	1.813	0.688	0.250	8.500	7.125	15.875

**Side Tap Mount**

Style F  
 (NFPA MS4)

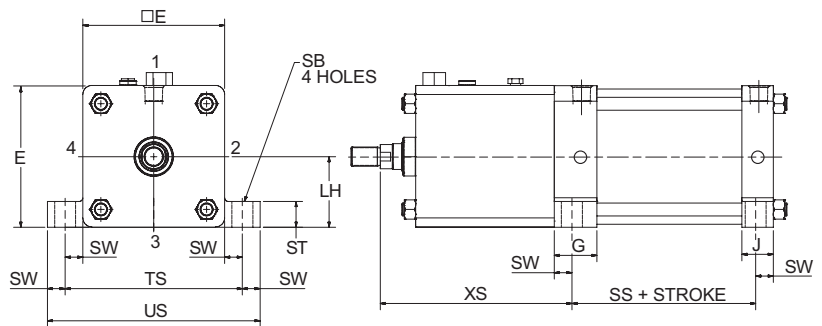
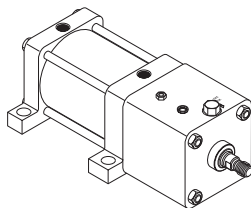


**Style F Dimensions**

Bore size	Rod no.	Rod dia. MM	E	ND	NT	+/- .003 TH	TN	XT	Add stroke SN
6	1	1-3/8	6.500	1.125	3/4-10	3.243	3.250	9.188	3.125
	3	1-3/4	6.500	1.125	3/4-10	3.243	3.250	9.938	3.125
8	1	1-3/8	8.500	1.125	3/4-10	4.243	4.500	9.438	3.250
	3	1-3/4	8.500	1.125	3/4-10	4.243	4.500	10.188	3.250

**Side Lug Mount**

Style C  
 (NFPA MS2)



**Style C Dimensions**

Bore size	Rod no.	Rod dia. MM	E	G	J	+/- .003 LH	SB	ST	SW	TS	US	XS	Add stroke SS
6	1	1-3/8	6.500	1.910	1.410	3.243	0.813	1.000	0.688	7.875	9.250	8.688	3.625
	3	1-3/4	6.500	1.910	1.410	3.243	0.813	1.000	0.688	7.875	9.250	9.438	3.625
8	1	1-3/8	8.500	1.810	1.440	4.243	0.813	1.000	0.688	9.875	11.250	8.938	3.750
	3	1-3/4	8.500	1.810	1.440	4.243	0.813	1.000	0.688	9.875	11.250	9.688	3.750

**B**  
 Tie Rod Pneumatic Cylinders  
 4MA Series  
 4MAJ Series  
 2MNR Series  
 ACVB Option  
 LPSO Option  
 PID Series



For inventory, lead time, and kit lookup, visit [www.pdnplu.com](http://www.pdnplu.com)

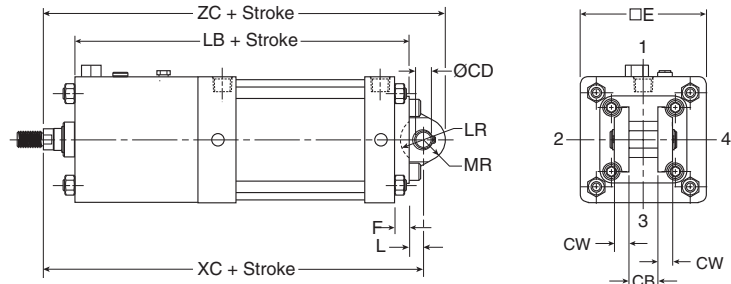
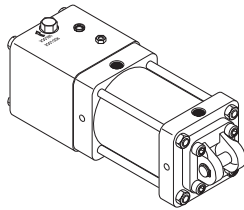
B59

**Parker Hannifin Corporation**  
 Pneumatic Division  
 Richland, Michigan  
[www.parker.com/pneumatics](http://www.parker.com/pneumatics)

**Cap Fixed Clevis**

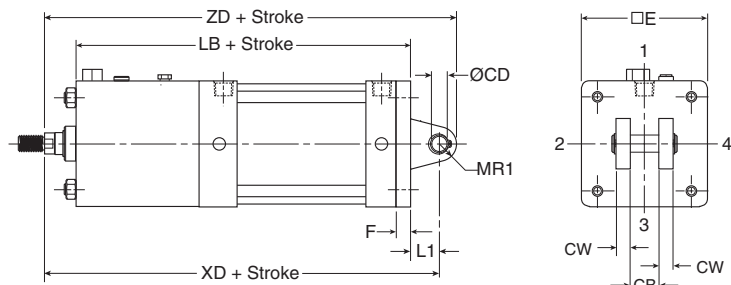
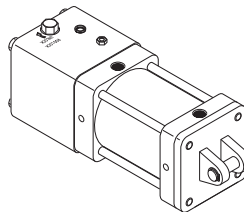
Style BB  
 (NFPA MP1)

**NOTE:** For maximum swivel angle of BB mount with rear mounting plate, please reference cylinder accessories on page B80.



**Cap Detachable Clevis**

Style BC  
 (NFPA MP2)

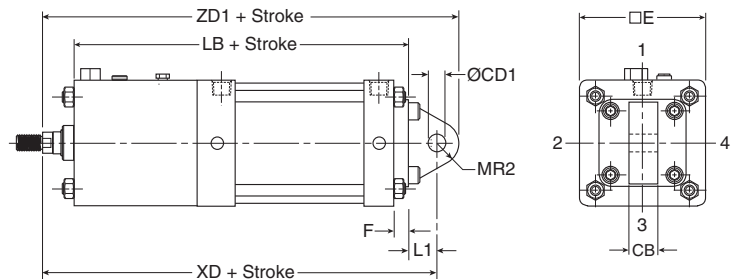
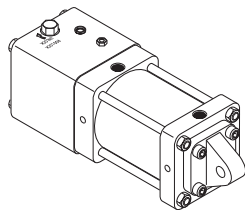


**Styles BB and BC Dimensions**

Bore size	Rod no.	Rod dia. MM	CB	Rod dia. +.000 -.002 CD	CW	E	F	L	L1	LR	MR	MR1	Add stroke LB	XC	XD	ZC	ZD
6	1	1-3/8	1.500	1.001	0.750	6.500	0.750	0.750	1.500	1.250	1.125	1.000	12.125	14.500	15.250	15.625	16.250
	3	1-3/4	1.500	1.001	0.750	6.500	0.750	0.750	1.500	1.250	1.125	1.000	12.625	15.250	16.000	16.375	17.000
8	1	1-3/8	1.500	1.001	0.750	8.500	0.750	0.750	1.500	1.250	1.125	1.000	12.500	14.875	15.625	16.000	16.625
	3	1-3/4	1.500	1.001	0.750	8.500	0.750	0.750	1.500	1.250	1.125	1.000	13.000	15.625	16.375	16.750	17.375

**Cap Detachable Eye Mount**

Style BE  
 (NFPA MP4)  
 (only 6" Bore)



**Style BE Dimensions**

Bore size	Rod no.	Rod dia. MM	CB	Rod dia. +.002 +.004 CD1	E	F	L1	MR2	Add stroke LB	XD	ZD1
6	1	1-3/8	1.500	1.000	6.500	0.750	1.500	1.125	12.125	15.250	16.375
	3	1-3/4	1.500	1.000	6.500	0.750	1.500	1.125	12.625	16.000	17.125



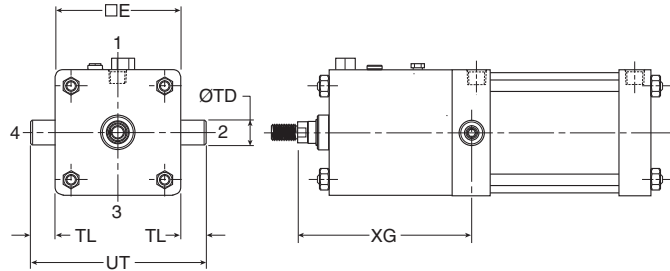
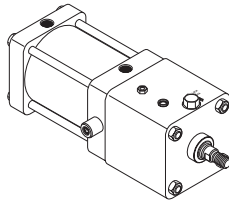
For inventory, lead times, and kit lookup, visit [www.pdnplu.com](http://www.pdnplu.com)

**B**  
 Tie Rod Pneumatic Cylinders  
 4MA Series  
 4MAJ Series  
 2MNR Series  
 ACVB Option  
 LPSO Option  
 P1D Series



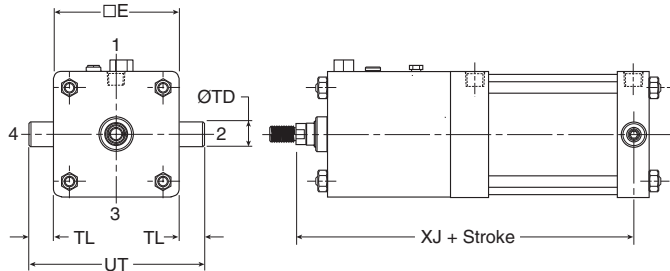
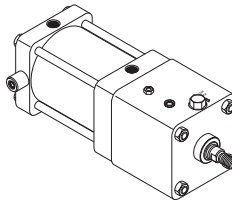
**Head Trunnion Mount**

Style D  
 (NFPA MT1)



**Cap Trunnion Mount**

Style DB  
 (NFPA MT2)

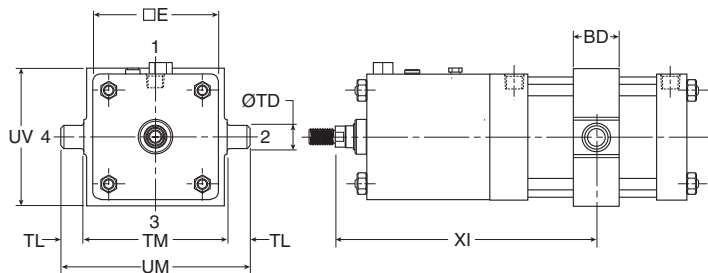
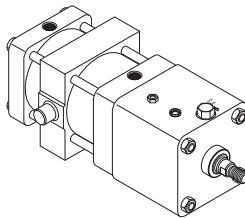


**Styles D and DB Dimensions**

Bore size	Rod no.	Rod dia. MM	E	+0.001 -0.001 TD	TL	UT	XG	XJ
6	1	1-3/8	6.500	1.375	1.375	9.250	9.000	12.250
	3	1-3/4	6.500	1.375	1.375	9.250	9.750	13.000
8	1	1-3/8	8.500	1.375	1.375	11.250	9.250	12.625
	3	1-3/4	8.500	1.375	1.375	11.250	10.000	13.375

**Intermediate Trunnion Mount**

Style DD  
 (NFPA MT4)



**Note:** Style DD requires minimum stroke per table.

**Style DD Dimensions**

Bore size	Rod no.	Rod dia. MM	E	BD	+0.001 -0.001 TD	TL	TM	UM	UV	Min. XI	Min. stroke
6	1	1-3/8	6.500	2.500	1.375	1.375	7.625	10.375	7.000	20.16	6.125
	3	1-3/4	6.500	2.500	1.375	1.375	7.625	10.375	7.000	20.19	6.125
8	1	1-3/8	8.500	2.500	1.375	1.375	9.750	12.500	9.500	26.31	6.500
	3	1-3/4	8.500	2.500	1.375	1.375	9.750	12.500	9.500	27.06	6.500

**Kits & Accessories**

See page B34 to B36.



For inventory, lead time, and kit lookup, visit [www.pdnplu.com](http://www.pdnplu.com)

B61

**Parker Hannifin Corporation**  
 Pneumatic Division  
 Richland, Michigan  
[www.parker.com/pneumatics](http://www.parker.com/pneumatics)

**How To Order ACVB Option**

**4MA ACVB**

**How to Order ACVB Option fully assembled to 4MA Cylinder**

**B**  
Tie Rod Pneumatic  
Cylinders

4MA Series  
4MAJ Series  
2MNR Series  
ACVB Option  
LPSO Option  
P1D Series



Bore Size
1.50
2.00
2.50
3.25
4.00
5.00

**Double Rod Cylinder**<sup>1</sup>  
Specify "K" only if double rod cylinder is required.

**Mounting Style**  
Specify mounting style code per available 4MA mount.

**Series**  
4MA

Ports
U NPTF

**Piston Rod Number**  
See 4MA section for more details.

**Stroke Length**  
Specify stroke length required in inches.

Cushion Head End
Blank Non-cushioned head end
C Cushioned head end

Seals
Blank Standard (nitrile seals)
E Fluorocarbon rod wiper and rod seal only
M Metallic rod wiper, nitrile seals

Cushion Cap End
Blank Non-cushioned cap end
C Cushioned cap end

Piston Rod Thread Type
A Standard (UNF Unified Thread)
W BSF British Fine
M Metric (see page B78)

Cylinder Construction
Blank Standard (extruded body, standard round lobe orientation) *
A Extruded body, round lobe orientation rotated 90 degrees from standard *
N Extruded body, round lobe orientation rotated 180 degrees from standard *
Z Extruded body, round lobe orientation rotated 270 degrees from standard *
T Aluminum round tube and carbon steel tie

**Special Modification**  
Specify "S" for ACVB options and any other special modification other than rod end. See examples below.

Rod Material and Gland Code
Blank Standard rod and gland
H Standard rod and HI LOAD gland
Y 17-4 PH stainless steel rod and standard gland
Z 17-4 PH stainless steel rod and HI LOAD gland
J 303 stainless steel rod and standard gland
K 303 stainless steel rod and HI LOAD gland
S 316 stainless steel rod and standard gland
T 316 stainless steel rod and HI LOAD gland

Piston Rod Thread Style
4 Small male
8 Intermediate male
9 Short female
55 For use with split coupler
3 Special (and specify all dimensions required)
6 Full male

\* See Table on page B5.

Piston Type
Blank Lipseals and magnetic ring (legacy) (standard for 4ML)
1 Lipseals, no magnetic ring (legacy)
2 Lipseals, no magnetic ring (aluminum piston)
3 Lipseals and magnetic ring (aluminum piston)
4 Bumper seals, no magnetic ring
6 Bumper seals and magnetic ring
B Lipseals, 1/4" thick bumpers both ends
H Lipseals, 1/4" thick bumper head end
C Lipseals, 1/4" thick bumper cap end
D Lipseals and magnetic ring, 1/4" thick bumpers both ends
F Lipseals and magnetic ring, 1/4" thick bumper head end
R Lipseals and magnetic ring, 1/4" thick bumper cap end

ACVB Minimum Stroke Requirements**	
Bore	4MA
Compact Manifold	
1.50	0.500
2.00	0.500
2.50	0.438
Full Manifold	
1.50	5.813
2.00	5.813
2.50	5.750
3.25	5.500
4.00	5.500
5.00	5.250

\*\* For desired strokes less than the minimum requirement, specify a stop tube for the cylinder assembly. Total stroke should be (desired net stroke) + (stop tube length to help exceed minimum stroke). Stop tube only available for 4MA with aluminum piston.

Example:  
1.50" bore 4MA with 5.000" of desired net stroke:  
Gross stroke = 5.813"  
Stop tube = 0.813"  
Net stroke = 5.000"

**Note:** place gross stroke in cylinder model number and specify stop tube length and net stroke in the item notes.

**Example**

2.00 CJ4MAUS14AC 6.000  
S = ACVB Valve Combination  
S = 3C2B54 Manifold Code  
(See following page.)

**Flow Control Option**

Add "S = with SP37 Flow Controls" to item notes

**Muffler Option**

Add "S = with EM Mufflers" to item notes

For ACVB with the 2A Series, please use the 2A Series Model Code and specify the following in the item notes:  
S = ACVB Valve Combination  
S = (Manifold Code from following page)



For inventory, lead times, and kit lookup, visit [www.pdnplu.com](http://www.pdnplu.com)

ACVB Series Valve/Manifold Codes

Valve Series	
3	B3
5	B5
6	B6

Pilot Source / Pilot Exhaust	
A	Internal - Port #1 / Tapped M5 (B5, B6 only)
B	Internal - Port #1 / Vented
0	None. Remote Pilot Valve

Voltage	
4	24 VDC
5	110 VAC
X	Remote Pilot

Manifold Type / Location	
C	Compact Manifold / Cap End (For use with B3 valve only)
D	Compact Manifold / Head End (For use with B3 valve only)
F	Full Manifold / Cap End (For use with B3, B5 or B6 valves)
G	Full Manifold / Head End (For use with B3, B5 or B6 valves)

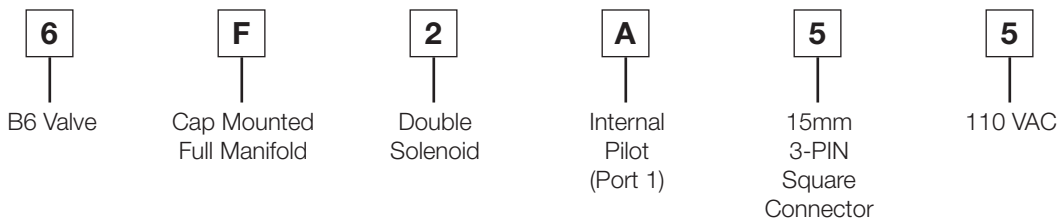
Operator Type / Function	
1	Single Solenoid / Air Return
2	Double Solenoid
3	Single Remote Pilot / Air Return
4	Double Remote Pilot

Connector / Valve Series Available	
(Connector can be rotated in 90° increments for Options A-H)	
0	None / B3, B5, B6 (Remote Pilot)
5	15mm 3-PIN DIN 43650C / B3, B5, B6 (Male Connector)
6	15mm 3-PIN DIN 43650C (rotated 180°) / B3, B5, B6 (Male Connector)
A	30mm Square 3-PIN ISO 4400 Form A / B5, B6 (Male Connector)
B	22mm Rectangular 3-PIN Type B Industrial / B5, B6 (Male Connector)
C	3-PIN Automotive Mini / B5 (Female Connector)
D	5-PIN Automotive Mini / B5 (Female Connector)
F	Hazardous Duty 1/2" Conduit 18" Leads / B5, B6
H	1/2" NPT Conduit 18" Leads / B5, B6

**NOTE:** Cylinders with single solenoid valves mounted at the CAP END will be NORMALLY RETRACTED. Cylinders with single solenoid valves mounted at the HEAD END will be NORMALLY EXTENDED.

Customer orientation of connector at 45 degree increments possible on Options A through H on B5 and B6 valves.

Example: 6 F 2 A 5 5



B
Tie Rod Pneumatic Cylinders
4MA Series
4MAJ Series
2MNR Series
ACVB Option
LPSO Option
P1D Series



For inventory, lead time, and kit lookup, visit [www.pdnplu.com](http://www.pdnplu.com)

B63

**Parker Hannifin Corporation**  
 Pneumatic Division  
 Richland, Michigan  
[www.parker.com/pneumatics](http://www.parker.com/pneumatics)

**Compact Manifold**



- Standard Fluid – Dry, filtered air.
- Standard Temperature: -5°F to 120°F (-15°C to 49°C).
- Maximum 145 PSI operating pressure.
- Fits 1-1/2" through 2-1/2" Bore 4MA standard cylinders.
- Uses standard Parker fittings, tubing, and seals.
- Compact manifold accommodates B3 Series valve from Parker Pneumatic Division North America without field modification to cylinder.

**Full Manifold**



- Standard Fluid: Dry, filtered air.
- Standard Temperature: -5° F to 120° F (-15°C to 49°C).
- Maximum 145 PSI operating pressure.
- Fits 1-1/2" through 5" Bore 4MA standard cylinders.
- Uses standard Parker fittings, tubing, and seals.
- Full manifold accommodates B3, B5 and B6 series Parker Pneumatic valves, without field modification to cylinder (B6 series shown).
- Bolt pattern conforms to NAMUR standard on B5 and B6 valves.
- Manifold and valve do not overhang beyond head or cap fasteners.

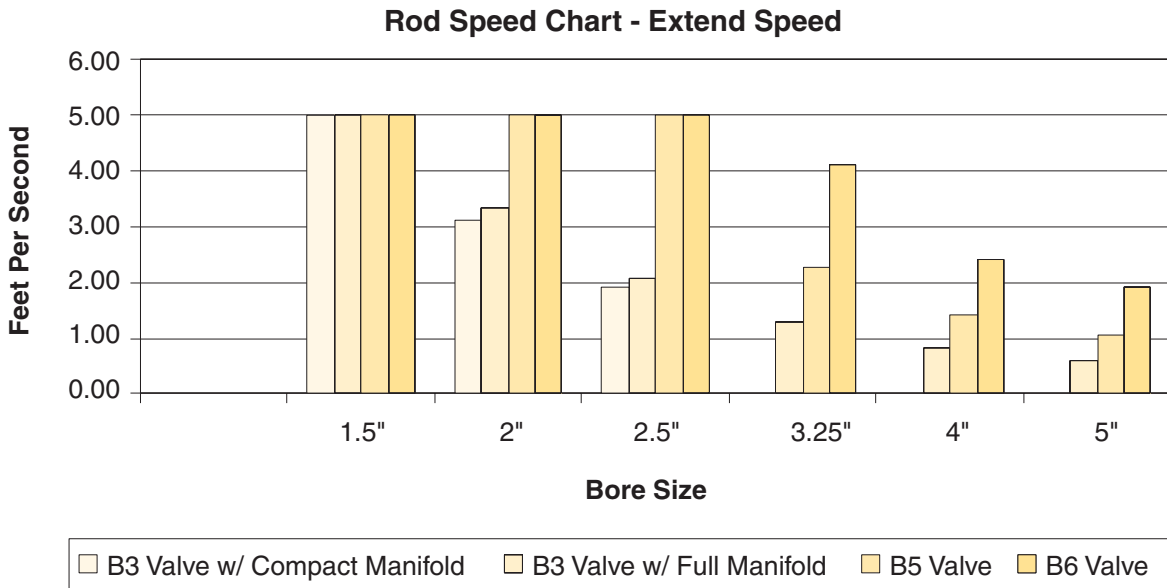
<b>B</b>
Tie Rod Pneumatic Cylinders
4MA Series
4MAJ Series
2MNR Series
ACVB Option
LPSO Option
P1D Series



For inventory, lead times, and kit lookup, visit [www.pdnplu.com](http://www.pdnplu.com)

B64

**Parker Hannifin Corporation**  
Pneumatic Division  
Richland, Michigan  
[www.parker.com/pneumatics](http://www.parker.com/pneumatics)



**Steps to size a cylinder-valve system**

**Step 1. Gather the Application Parameters**

- Total load
- Maximum velocity needed to move load in specified time\*
- Minimum pressure available

**Step 2. Size Cylinder**

Use equations in engineering section of Pneumatic Actuator Catalog to calculate minimum bore size

**Step 3. Size Valve/Manifold**

- Use the Rod Speed Chart above
- Choose valve/manifold system that will supply maximum velocity needed for bore size chosen above

**Step 4. Choose the Appropriate Model Code\*\***

- Specify necessary valve and manifold
- Choose type of control required
- Choose type of connection and voltage required

\* If maximum velocity is not easily calculated, divide the total stroke distance by the total stroke time and multiply by 2.

\*\* See the ACVB Series Valve/Manifold Code page for more details.

B
Tie Rod Pneumatic Cylinders
4MA Series
4MAJ Series
2MNR Series
ACVB Option
LPSO Option
PID Series

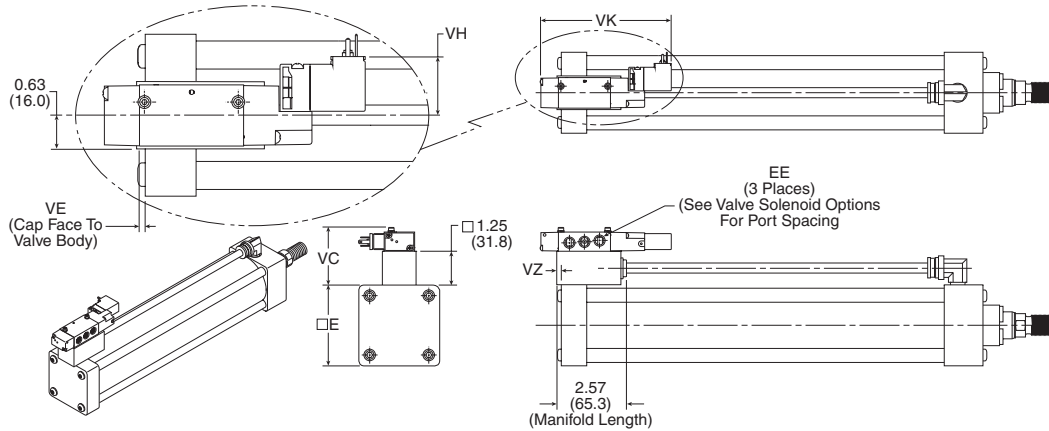


For inventory, lead time, and kit lookup, visit [www.pdnplu.com](http://www.pdnplu.com)

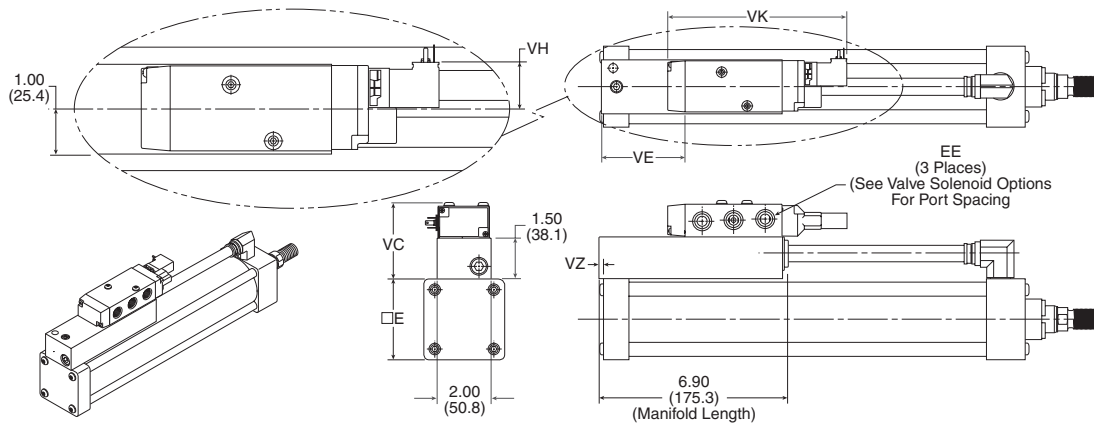
B65

**Parker Hannifin Corporation**  
 Pneumatic Division  
 Richland, Michigan  
[www.parker.com/pneumatics](http://www.parker.com/pneumatics)

**Compact Manifold**



**Full Manifold**



**Dimensions**

Bore	E (SQ.)	Manifold	Valve	VE*	VZ**		
1-1/2	2	Compact	B3	0.17 (4.3)	0.23 (5.8)		
			B3	3.78 (96.3)	0.23 (5.8)		
			B5	3.48 (88.4)	0.13 (3.3)		
		Full	B6	2.97 (75.4)	0.13 (3.3)		
			Compact	B3	0.17 (4.3)	0.23 (5.8)	
				B3	3.78 (96.3)	0.13 (3.3)	
B5	3.36 (85.3)	0.13 (3.3)					
2	2-1/2	Full	B6	2.97 (75.4)	0.13 (3.3)		
			Compact	B3	0.17 (4.3)	0.23 (5.8)	
				B3	3.78 (96.3)	0.13 (3.3)	
		B5		3.36 (85.3)	0.13 (3.3)		
		2-1/2	3	Full	B6	2.97 (75.4)	0.13 (3.3)
					Compact	B3	0.17 (4.3)
B3	3.78 (96.3)					0.13 (3.3)	
B5	3.36 (85.3)			0.13 (3.3)			
3-1/4	3-3/4			Full	B6	2.97 (75.4)	0.13 (3.3)
					B3	3.90 (99.1)	0.00
		B3	3.78 (96.3)		0.13 (3.3)		
		B5	3.48 (88.4)		0.00		
		B6	3.10 (78.7)		0.00		
		4	4-1/2		Full	B3	3.90 (99.1)
B5	3.48 (88.4)			0.00			
B6	3.10 (78.7)			0.00			
B3	3.90 (99.1)			0.00			
B5	3.48 (88.4)			0.00			
B6	3.10 (78.7)			0.00			
5	5-1/2	Full	B3	3.90 (99.1)	0.00		
			B5	3.48 (88.4)	0.00		
			B6	3.10 (78.7)	0.00		

Valve	EE		VK	VC	
	(NPTF)	VH			
B3	1/8	1.09 (27.7)	4.67 (118.6)	Compact Manifold	2.12 (53.8)
				Full Manifold	2.37 (60.2)
B5	1/4	1.12 (28.4)	5.78 (146.8)	Full Manifold	2.81 (71.4)
B6	3/8	1.12 (28.4)	6.67 (169.4)	Full Manifold	2.81 (71.4)

\* VE = Dimension from edge of endcap to edge of valve body.

\*\* VZ = Dimension from edge of endcap to edge of manifold.

**Note:** Dimensions shown are for a single solenoid enclosure with Option 5. For other valve or enclosure option dimensions, see pages B68-B69.

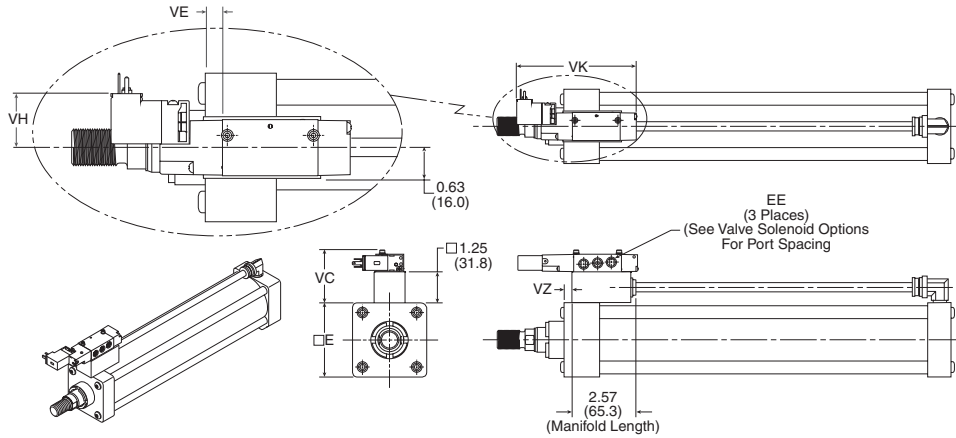
**B**  
Tie Rod Pneumatic Cylinders

4MA Series  
4MAJ Series  
2MNR Series  
ACVB Option  
LPSO Option  
P1D Series

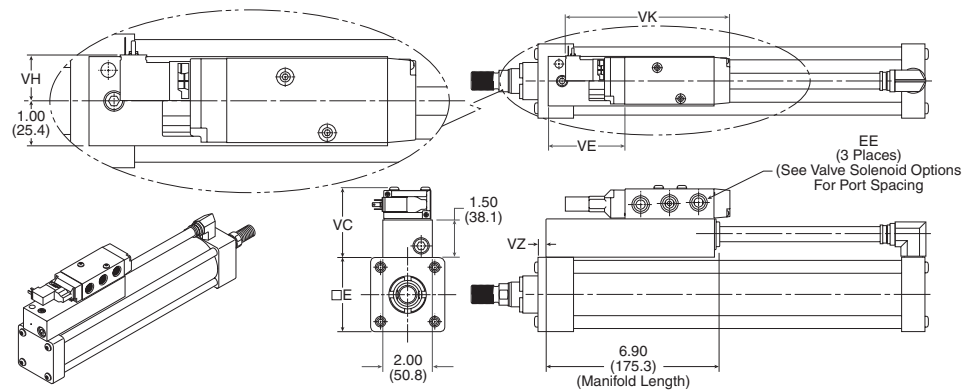


For inventory, lead times, and kit lookup, visit [www.pdnplu.com](http://www.pdnplu.com)

**Compact Manifold**



**Full Manifold**



**Dimensions**

Bore	E (SQ.)	Manifold	Valve	VE*	VZ**
1-1/2	2	Compact	B3	0.26 (6.6)	0.20 (5.1)
			B3	4.21 (106.9)	0.31 (7.9)
			B5	3.79 (96.3)	0.31 (7.9)
		Full	B6	3.41 (86.6)	0.31 (7.9)
			B3	0.26 (6.6)	0.20 (5.1)
			B3	4.21 (106.9)	0.31 (7.9)
2	2-1/2	Compact	B5	3.79 (96.3)	0.31 (7.9)
			B6	3.41 (86.6)	0.31 (7.9)
			B3	4.21 (106.9)	0.31 (7.9)
		Full	B3	0.33 (8.4)	0.27 (6.9)
			B3	4.27 (108.5)	0.38 (9.6)
			B5	3.86 (98.0)	0.38 (9.6)
2-1/2	3	Compact	B6	3.47 (88.1)	0.38 (9.6)
			B3	4.40 (111.8)	0.50 (12.7)
			B5	3.98 (101.1)	0.50 (12.7)
		Full	B6	3.60 (91.4)	0.50 (12.7)
			B3	4.40 (111.8)	0.50 (12.7)
			B5	3.98 (101.1)	0.50 (12.7)
3-1/4	3-3/4	Compact	B6	3.60 (91.4)	0.50 (12.7)
			B3	4.40 (111.8)	0.50 (12.7)
			B5	3.98 (101.1)	0.50 (12.7)
		Full	B6	3.60 (91.4)	0.50 (12.7)
			B3	4.40 (111.8)	0.50 (12.7)
			B5	3.98 (101.1)	0.50 (12.7)
4	4-1/2	Compact	B6	3.60 (91.4)	0.50 (12.7)
			B3	4.40 (111.8)	0.50 (12.7)
			B5	3.98 (101.1)	0.50 (12.7)
		Full	B6	3.60 (91.4)	0.50 (12.7)
			B3	4.40 (111.8)	0.50 (12.7)
			B5	3.98 (101.1)	0.50 (12.7)
5	5-1/2	Compact	B6	3.60 (91.4)	0.50 (12.7)
			B3	4.40 (111.8)	0.50 (12.7)
			B5	3.98 (101.1)	0.50 (12.7)
		Full	B6	3.60 (91.4)	0.50 (12.7)
			B3	4.40 (111.8)	0.50 (12.7)
			B5	3.98 (101.1)	0.50 (12.7)

Valve	EE			VC	
	(NPTF)	VH	VK		
B3	1/8	1.09 (27.7)	4.67 (118.6)	Compact Manifold	2.12 (53.8)
				Full Manifold	2.37 (60.2)
B5	1/4	1.12 (28.4)	5.78 (146.8)	Full Manifold	2.81 (71.4)
B6	3/8	1.12 (28.4)	6.67 (169.4)	Full Manifold	2.81 (71.4)

\* VE = Dimension from edge of endcap to edge of valve body.

\*\* VZ = Dimension from edge of endcap to edge of manifold.

**Note:** single solenoid enclosure 5 shown. For other valve or options, see pages B68-B69.



For inventory, lead time, and kit lookup, visit [www.pdnplu.com](http://www.pdnplu.com)

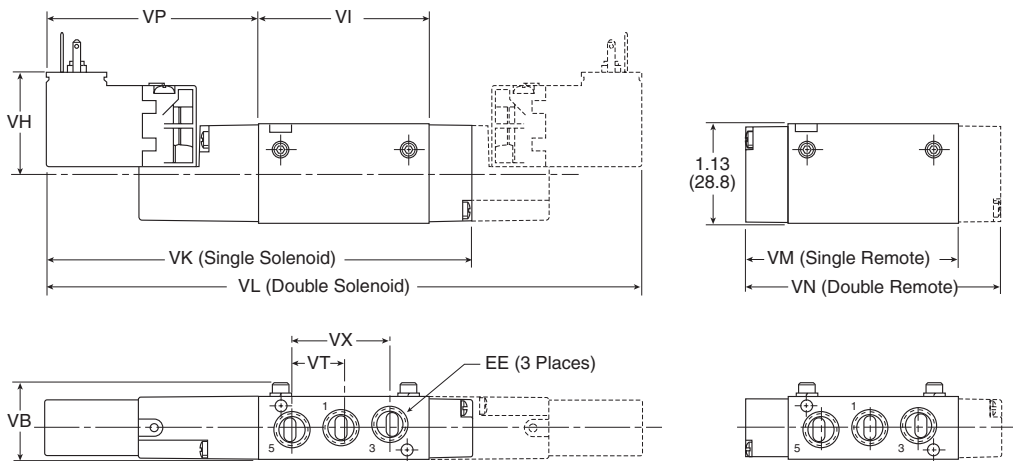
B67

**Parker Hannifin Corporation**  
 Pneumatic Division  
 Richland, Michigan  
[www.parker.com/pneumatics](http://www.parker.com/pneumatics)

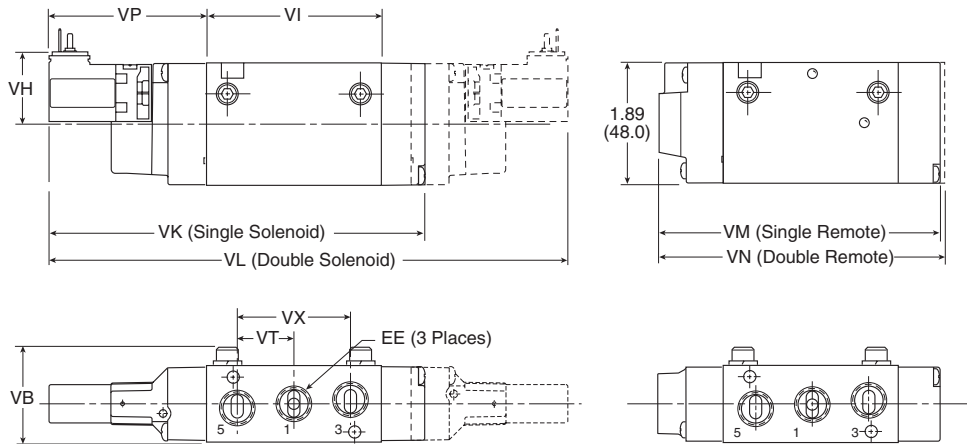
Valve Solenoid Options

4MA ACVB

B3 Valve



B5 and B6 Valve



Valve Dimensions

Valve	EE (NPTF)	VB	VH	VI	VK	VL	VM	VN	VP	VT	VX
B3	1/8	0.87 (22.1)	1.09 (27.7)	1.93 (49.0)	4.67 (118.6)	6.44 (163.6)	3.12 (79.2)	3.33 (84.6)	2.25 (57.2)	0.56 (14.2)	1.12 (28.4)
B5	1/4	1.31 (33.3)	1.12 (28.4)	2.70 (68.6)	5.78 (146.8)	7.51 (190.8)	4.37 (111.0)	4.70 (119.4)	2.40 (61.0)	0.88 (22.4)	1.75 (44.5)
B6	3/8	1.31 (33.3)	1.12 (28.4)	3.60 (91.5)	6.67 (169.4)	8.41 (213.6)	5.26 (133.6)	5.59 (142.0)	2.40 (61.0)	1.17 (29.7)	2.34 (59.4)



For inventory, lead times, and kit lookup, visit [www.pdnplu.com](http://www.pdnplu.com)

B68

**Parker Hannifin Corporation**  
Pneumatic Division  
Richland, Michigan  
[www.parker.com/pneumatics](http://www.parker.com/pneumatics)

**B** Tie Rod Pneumatic Cylinders

4MA Series

4MAJ Series

2MNR Series

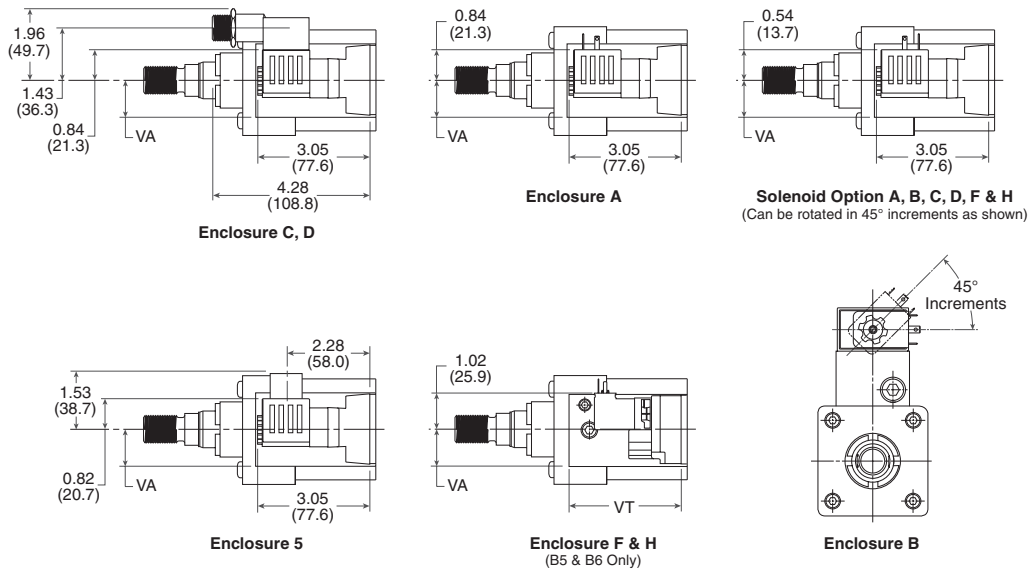
ACVB Option

LPSO Option

P1D Series



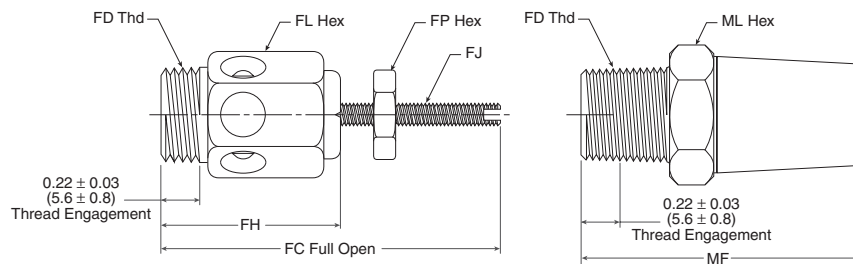
**Optional Electrical Connections**



**Optional Electrical Connections Dimensions**

Valve	VA	VT
B3	0.63 (16.0)	2.25 (57.2)
B5	1.00 (25.4)	2.40 (61.0)
B6	1.00 (25.4)	2.40 (61.0)

**Optional Flow Controls / Mufflers**



**Optional Flow Controls / Mufflers Dimensions**

Valve	FC	FD	FJ	FH	FL	FP	MF	ML
B3	1.48 (37.6)	1/8	10-32	0.90 (22.9)	1/2	3/8	1.00 (25.4)	7/16
B5	1.92 (48.8)	1/4	1/4-28	1.17 (29.7)	9/16	7/16	1.32 (33.5)	9/16
B6	1.92 (48.8)	3/8	1/4-28	1.27 (32.3)	11/16	7/16	1.54 (39.1)	11/16

**B**

Tie Rod Pneumatic Cylinders

4MA Series

4MAJ Series

2MNR Series

ACVB Option

LPSO Option

P1D Series



For inventory, lead time, and kit lookup, visit [www.pdnplu.com](http://www.pdnplu.com)

**Manifold Kits Without Valve**

	Compact manifold	Full manifold	
<b>Bore Size</b>	1-1/2", 2", and 2-1/2"	1-1/2", 2" and 2-1/2"	3-1/4", 4", and 5"
Kit w/ Tubing	<b>L078350000</b>	<b>L078380000</b>	<b>L078390000</b>
Kit w/o Tubing	<b>L078370000</b>	<b>L078400000</b>	<b>L078410000</b>
Max. Stroke for Kit w/ Tubing*	34.5"	39.5"	39"
Tubing Part #	<b>0880383836</b>	<b>0880386336</b>	

**Example:**

**Manifold Kits:**

**Without Tubing Include:**

- Manifold
- Grease
- O-rings for all applicable valves
- All necessary fasteners
- All necessary fittings
- Assembly Instructions

**With Tubing Include:**

- All "without tubing" items
- 36" of appropriate tubing
  - 3/8" O.D. for compact manifold
  - 5/8" O.D. for full manifold
- See above table for maximum stroke lengths.

**Valve:**

**To Order Valve:**

- Consult latest revision of Parker Pneumatic Products (Catalog #0600P).
- Specify "T" code as port size/thread type on B3, B5 or B6 valve order.
- All valves supplied with flush, locking overrides (code 'C').
- Manifolds designed for 2 position valves only.

**Example: B61TBCH49A defines:**

B6 ACVB Single Solenoid Valve, Flush Locking Override, with 1/2" NPT conduit, using 24VDC voltage.

**Flow Controls & Mufflers:**

Order as separate line items.

Valve size	Port size (NPTF)	Flow control part no.	Muffler part no.
B3	1/8	<b>045020002</b>	<b>EM12</b>
B5	1/4	<b>045040004</b>	<b>EM25</b>
B6	3/8	<b>045060060</b>	<b>EM37</b>

 **WARNING**

The Prestomatic fittings on the manifold and cylinder end caps are to be used in conjunction with Parker Air Brake tubing PFT-6B and PFT-10B only. The use of other tubing may not be compatible with the Prestomatic fittings. This may lead to a tubing failure which could cause the cylinder piston rod to suddenly retract or extend at high speed.

**B**  
Tie Rod Pneumatic Cylinders

4MA Series

4MAJ Series

2MNR Series

ACVB Option

LPSO Option

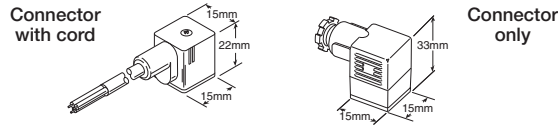
P1D Series



For inventory, lead times, and kit lookup, visit [www.pdnplu.com](http://www.pdnplu.com)

**Female Electrical Connectors**

**15mm 3-Pin DIN 43650C**



	Cord length	Connector	Connector with cord
Unlighted	6 Feet	<b>PS2932BP</b>	<b>PS2932JBP</b>
Light – 24VAC or DC	6 Feet	<b>PS294679BP</b>	<b>PS2946J79BP*</b>
Light – 110/120VAC	6 Feet	<b>PS294683BP</b>	<b>PS2946J83BP*</b>

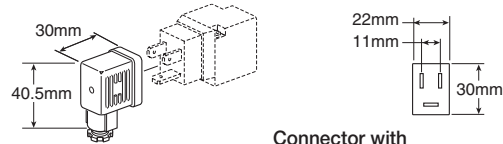
\* LED with surge suppression.

**Note:** Max ø6.5mm cable size required for connector w/o 6' (2m) cord. IP65 rated when properly installed.

**Engineering data:**

Conductors: 2 poles plus ground  
Cable range (connector only): 4 to 6mm (0.16 to 0.24 Inch)  
Contact spacing: 8mm

**22mm Rectangular 3-Pin – Type B Industrial (Use with Enclosure “B”)**



Description	Connector with 6' (2m) cord	Connector
Unlighted	<b>PS2429JBP</b>	<b>PS2429BP</b>
Light – 24V60Hz, 24VDC	<b>PS2430J79BP*</b>	<b>PS243079BP</b>
Light – 120V/60Hz	<b>PS2430J83BP*</b>	<b>PS243083BP</b>

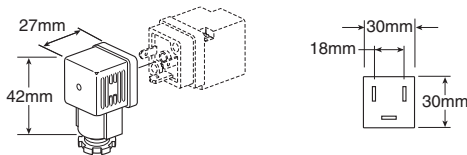
\* LED with surge suppression.

**Note:** Max ø6.5mm cable size required for connector w/o 6' (2m) cord. IP65 rated when properly installed.

**Engineering data:**

Conductors: 2 poles plus ground  
Cable range (connector only): 6 to 8mm (0.24 to 0.31 Inch)  
Contact spacing: 11mm

**30mm Square 3-Pin – ISO 4400, DIN 43650A (Use with Enclosure “A”)**



Description	Connector with 6' (2m) cord	Connector
Unlighted	<b>PS2028JCP</b>	<b>PS2028BP</b>
Light – 6-48V, 50/60Hz, 6-48VDC	<b>PS2032J79CP*</b>	<b>PS203279BP</b>
Light – 120V/60Hz	<b>PS2032J83CP*</b>	<b>PS203283BP</b>

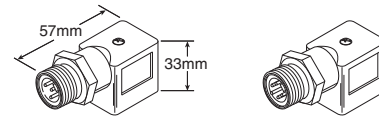
\* LED with surge suppression.

**Note:** Max ø6.5mm cable size required for connector w/o 6' (2m) cord. IP65 rated when properly installed.

**Engineering data:**

Conductors: 2 poles plus ground  
Cable range (connector only): 8 to 10mm (0.31 to 0.39 Inch)  
Contact spacing: 8mm

**3-Pin / 5-Pin Male Automotive Connectors (Use on 22mm Rectangular 3-Pin Solenoid)**



Description	3-pin	5-pin
Unlighted	<b>PS2893CP</b>	<b>PS2893DP</b>
Lighted - Voltage	<b>PS2893C##P</b>	<b>PS2893D83P</b>

## – 79 = 24VDC & 24VAC  
83 = 120VAC

**B**

Tie Rod Pneumatic Cylinders

4MA Series

4MAJ Series

2MNR Series

ACVB Option

LPSO Option

P1D Series

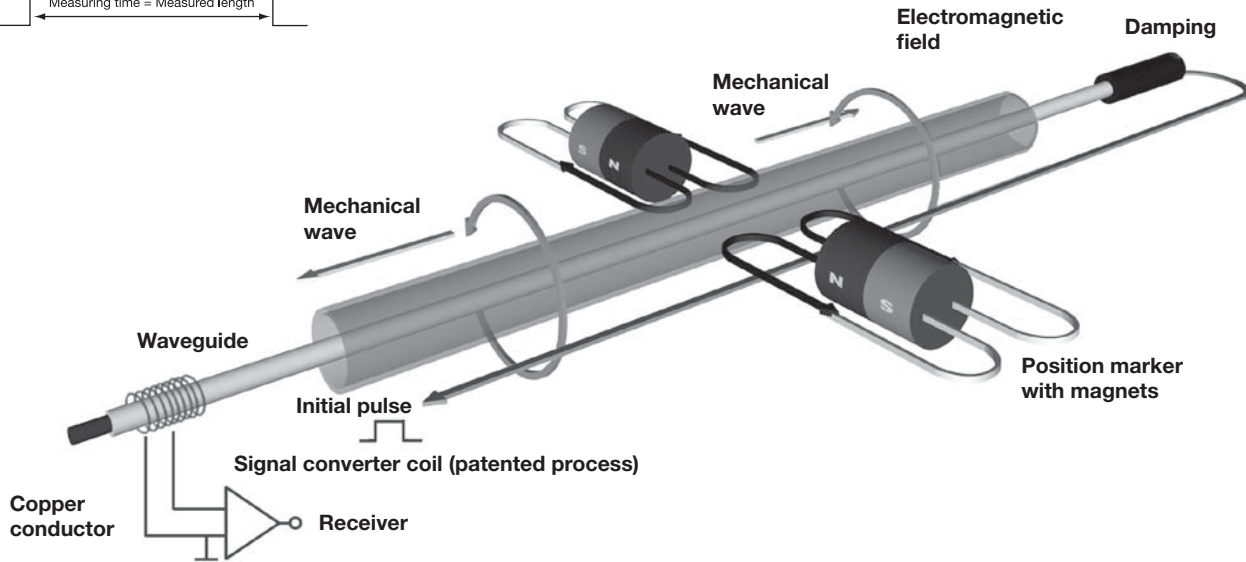
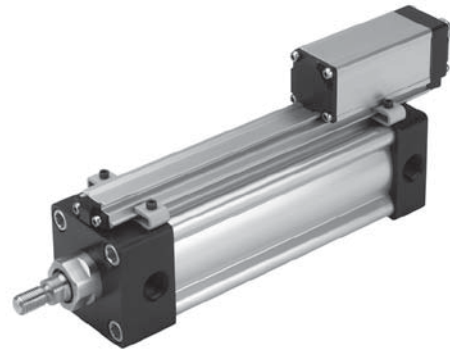
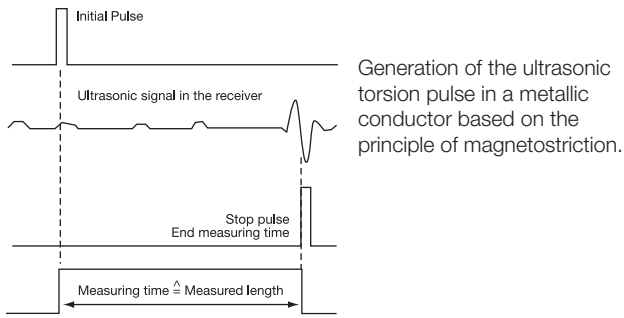


For inventory, lead time, and kit lookup, visit [www.pdnplu.com](http://www.pdnplu.com)

**Linear Position Sensor Option**

**Linear Position Sensor for Continuous Position Feedback**

B	Tie Rod Pneumatic Cylinders
4MA	Series
4MAJ	Series
2MNR	Series
ACVB	Option
LPSO	Option
P1D	Series



**Principles of Operation**

The measuring element ("waveguide"), consists of a special nickel-alloy tube.

A copper conductor is introduced through the length of this tube. The start of measurement is initiated by a short current pulse.

This current generates a circular magnetic field which rotates around the waveguide. A permanent magnet at the point of measurement is used as the marker element, whose lines of field run at right angles to the electromagnetic field. In the area on the waveguide where the two fields intersect, a magneto-strictive effect causes an elastic deformation of the waveguide, which propagates along the wave guide in both directions in the form of a mechanical wave.

The propagation velocity of this wave in the waveguide is 2830 m/s, and is nearly insensitive to environmental effects (e.g., temperature, shock, contamination).

The component of the wave which reaches the far end of the waveguide is damped there, whereas the component which arrives at the signal converter is changed into an electrical

signal by reversing the magnetostrictive effect. The wave travel time from its point of origin to the signal converter is directly proportional to the distance between the permanent magnet and the signal converter. A time measurement then allows the distance to be determined with extremely high accuracy.

**Design**

The transducers are made to the same safety and reliability standards for use in the harshest conditions:

- The electronics unit is compactly designed using SMD technology. The boards are protected in a space-saving, rugged aluminum extruded housing.
- The waveguide is protected in the extruded aluminum housing.

**Quality**

Each and every transducer undergoes a specially designed, computer-controlled testing procedure which includes 100% checking of all specified data.

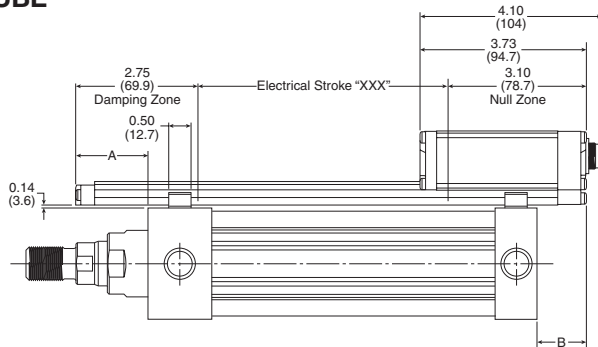


For inventory, lead times, and kit lookup, visit [www.pdnplu.com](http://www.pdnplu.com)

## Linear Position Sensor Option

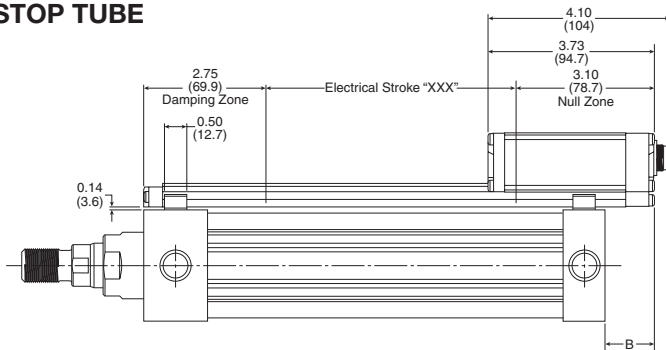
The drawings below show that the Linear Position Sensor is longer than the cylinder of the same stroke length. The sensor overhang on the head end of the cylinder, as indicated by dimension A, may be eliminated by adding stop tubing, which effectively increases the gross stroke of the cylinder. The recommended stop tube lengths are provided in the table

### NO STOP TUBE



Example A: 12" Stroke cylinder without stop tube equals 12" Electrical Stroke for the Sensor.

### WITH STOP TUBE

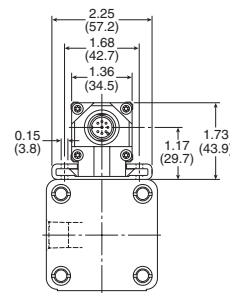
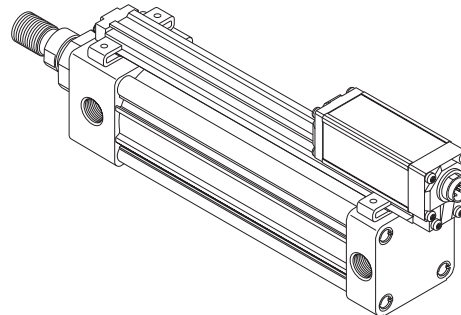


**Example B:** To eliminate sensor overhang on the head end of a 2.0" bore cylinder, add 1.0" of recommended stop tube length. The cylinder gross stroke becomes 13" and the net stroke remains 12". Specify a sensor with an electrical stroke of 12". Note that the electrical stroke equals cylinder **net** stroke length.

## Tie Rod Pneumatic Cylinders 4MA with LPSO

below for each bore size. The examples show that the electrical stroke of the sensor will always match the **net** stroke of the cylinder.

As a result of the limited sensing range of the sensor, it will overhang at the cap end of the cylinder by the amount of dimension B.



**Example C:** To eliminate sensor overhang on the head end of a 5.0" bore cylinder, add 0.625" of recommended stop tube length. The cylinder gross stroke becomes 12.625" and the net stroke remains 12". Specify a sensor with an electrical stroke of 12". Note that the electrical stroke equals cylinder **net** stroke length.

Bore	Rod code	Rod diameter	No stop tube		With stop tube		
			A	B	Stop tube length	A <sub>1</sub>	B
2	1	5/8	0.95	1.3	1.0	0	1.3
	3	1					
2-1/2	1	5/8	0.90	1.25	1.0	0	1.25
	3	1					
3-1/4	1	1	0.64	1.0	0.75	0	1.0
	3	1-3/8					
4	1	1	0.63	0.99	0.75	0	0.99
	3	1-3/8					
5	1	1	0.55	0.79	0.625	0	0.79
	3	1-3/8					
6	1	1-3/8	0.47	0.46	0.50	0	0.45
	3	1-3/4					
8	1	1-3/8	0.28	0.44	0.375	0	0.44
	3	1-3/4					



For inventory, lead time, and kit lookup, visit [www.pdnplu.com](http://www.pdnplu.com)

B73

**Parker Hannifin Corporation**  
Pneumatic Division  
Richland, Michigan  
[www.parker.com/pneumatics](http://www.parker.com/pneumatics)

**Analog Interface Profile Series**

**Tie Rod Pneumatic Cylinders  
4MA with LPSO**

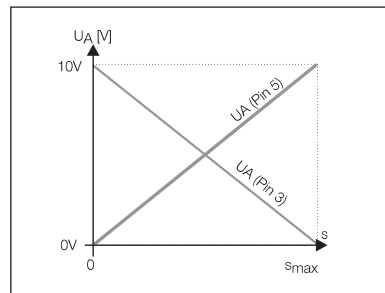
Output signal \_\_\_\_\_  
 Transducer interface \_\_\_\_\_  
 Input interface \_\_\_\_\_

analog \_\_\_\_\_  
**A** \_\_\_\_\_  
 analog \_\_\_\_\_

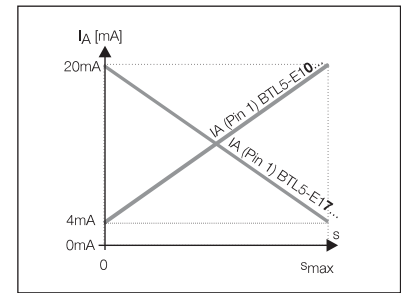
analog \_\_\_\_\_  
**E** \_\_\_\_\_  
 analog \_\_\_\_\_

**B**  
 Tie Rod Pneumatic  
 Cylinders

Series  
 4MA  
 4MAJ  
 2MNR  
 ACVB  
 LPSO  
 P1D



BTL5-A11-M-\_-RSU022S32



BTL5-E1\_-M-\_-RSU022S32

Ordering code \_\_\_\_\_

Output voltage \_\_\_\_\_  
 Output current \_\_\_\_\_  
 Load current \_\_\_\_\_  
 Max. ripple \_\_\_\_\_  
 Load resistance \_\_\_\_\_  
 System resolution \_\_\_\_\_

**0...10 V** \_\_\_\_\_  
 max. 10 mA \_\_\_\_\_  
 ≤ 5 mV \_\_\_\_\_  
**≤ 0.1 mV** \_\_\_\_\_

**4...20 mA** \_\_\_\_\_  
 ≤ 500 Ohm \_\_\_\_\_  
**≤ 0.2 μA** \_\_\_\_\_

Hysteresis \_\_\_\_\_  
 Repeatability \_\_\_\_\_  
 Output update rate \_\_\_\_\_  
 Max. non-linearity \_\_\_\_\_

≤ 4 μm \_\_\_\_\_  
 6 μm (hysteresis + resolution) \_\_\_\_\_  
 STANDARD = 1 ms <sup>1</sup>400 mm \_\_\_\_\_  
 ±100 μm to 500 mm stroke \_\_\_\_\_  
 ±0.02 % 501...3606 mm stroke \_\_\_\_\_

Temperature coefficient Voltage output \_\_\_\_\_  
 Current output \_\_\_\_\_

[150 μV/°C + (5 ppm/°C x PxU/L)] x DT \_\_\_\_\_  
 [0.6 μA/°C + (10 ppm/°C x PxI/L)] x DT \_\_\_\_\_

Shock loading \_\_\_\_\_  
 Vibration \_\_\_\_\_  
 Traverse velocity of magnet \_\_\_\_\_

100 g/11 ms per IEC 68-2-27 \_\_\_\_\_  
 12 g, 10...2000 Hz per IEC 68-2-6 \_\_\_\_\_

Operating voltage \_\_\_\_\_  
 Current draw \_\_\_\_\_  
 Polarity reversal protected \_\_\_\_\_

any \_\_\_\_\_  
 24 V DC ± 20% \_\_\_\_\_  
 ≤ 150 mA \_\_\_\_\_  
 yes \_\_\_\_\_

Overvoltage protection \_\_\_\_\_  
 Dielectric constant \_\_\_\_\_  
 Operating temperature \_\_\_\_\_  
 Storage temperature \_\_\_\_\_

Transzorb protection diodes \_\_\_\_\_  
 500 V (Ground to housing) \_\_\_\_\_  
 -40...185 °F (-40...85°C) \_\_\_\_\_  
 -40...212 °F (-40...100°C) \_\_\_\_\_

S32 Pin assignments	Pin	Color
Output signals	1	YE
	2	GY
	3	PK
	5	GN
Supply voltage	6	BU
	7	BN
	8	WH

BTL5-A11...
not used
signal GND
10...0 V
0...10 V
GND
+24 V DC
(GND)

BTL5-E1...BTL5-E7...
4...20 mA    20...4 mA
0 V output
10...0 V
0...10 V
GND
+24 V DC
(GND)

Connect shield to housing.

**Specifications subject to change.**

**Please enter code for output signal and nominal stroke in ordering code.**

BTL transducers with analog outputs are available in the ranges of 0...10V, 4...20mA with rising or falling signal.

Ordering Sample:

**BTL5-A11-M-\_-R-SU 022S32**

**Output signal**  
 1 increasing and decreasing (for A)  
 0 increasing  
 7 decreasing (for E)

**Standard stroke lengths (mm)**



For inventory, lead times, and kit lookup, visit [www.pdnplu.com](http://www.pdnplu.com)

**M Interface**

Differential **START/STOP** control-specific interface.

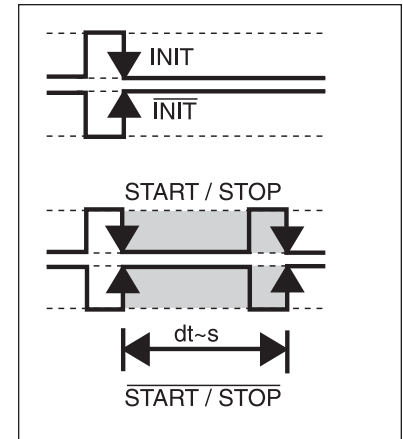
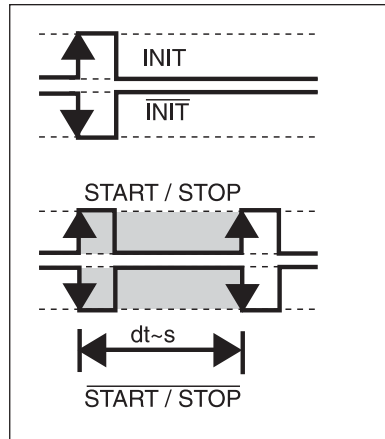
**P Interface**

Compatible with BTA processors and various OEM controls. Reliable signal transmission, even over cable lengths up to 500 m (1640 ft.) between BTA and BTL, is assured by the especially noise-immune RS485 differential drivers and receivers. Noise signals are effectively suppressed.

Series
Transducer interface
User interface

BTL5 Low Profile
pulse <b>M</b>
pulse <b>M</b>

BTL5 Low Profile
pulse <b>P</b>
pulse <b>P</b>



Ordering code
System resolution
Repeatability
Resolution
Hysteresis
Standard sampling rate
Max. non-linearity
Temperature coefficient of overall system
Traverse velocity of magnet
Operating voltage
Current draw
Operating temperature
Storage temperature

BTL5-**M**1-M\_\_\_\_-RSU022S32

BTL5-**P**1-M\_\_\_\_-RSU022S32

Process-dependent/control dependent
Hysteresis + Resolution
≤ 2 μm
≤ 4 μm
STANDARD = 1 kHz ≤1400 mm
±100 μm to 500 mm nominal stroke
±0.02 % 501...3750 mm nominal stroke
(6 μm + 5 ppm x L)/°C
any
24 V DC ±20 % or ±15V DC ±2% (optional)
≤ 100 mA
-40...185 °F (-40...85°C)
-40...212 °F (-40...100°C)

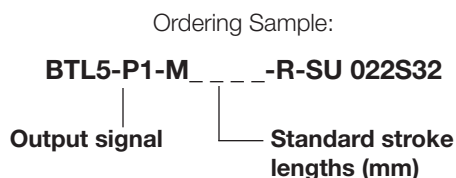
S32 Pin assignments	Pin	Color
Input/output signals	Input	1 YE
	Output	2 GY
	Input	3 PK
	Output	5 GN
Supply voltage	6	BU
	7	BN
	8	WH

BTL5- <b>M</b> 1-M...	BTL5- <b>P</b> 1-M...
INIT	INIT
START/STOP	START/STOP
INIT	INIT
START/STOP	START/STOP
GND	GND
+24 V DC	+24 V DC
(GND)	(GND)

Shield connected to housing

Specifications subject to change.

Please enter code for nominal stroke in ordering code.



For inventory, lead time, and kit lookup, visit [www.pdnplu.com](http://www.pdnplu.com)

B75

**Parker Hannifin Corporation**  
Pneumatic Division  
Richland, Michigan  
[www.parker.com/pneumatics](http://www.parker.com/pneumatics)

How To Order LPSO Option

Sensor Ordering Code

**B** Tie Rod Pneumatic Cylinders

**4MA** Series

**4MAJ** Series

**2MNR** Series

**ACVB** Option

**LPSO** Option

**P1D** Series

**BTL-5** - **A** **1** **1** - **M** **0305** - **R** **SU022** **S32**

Output Signal	
<b>A</b>	0...10V
<b>E</b>	4...20mA
<b>M</b>	Differential Start/Stop, leading edge active
<b>P</b>	Differential Start/Stop, trailing edge active

Nominal Stroke	
Specify whole mm using 4 digits, i.e. 0305 = 305mm active electrical stroke*	
* Electrical stroke = net cylinder stroke.	

Connection Type	
<b>S32</b>	8-pin Quick Disconnect Metal Connector
<b>KA05</b>	Integral Axial Cable (specify cable length in whole meters using 2 digits, i.e. 05 = 5m)

Supply Voltage	
<b>1</b>	24 V ±20%

Housing Geometry	
<b>R</b>	Low Profile Extrusion

Output Signal (Analog only)	
<b>1</b>	Vmin or Vmax at Connector End, i.e. user selectable rising or falling*
<b>0</b>	Imin at Connector End (rising toward opposite end)**
<b>7</b>	Imax at Connector End (falling toward opposite end)**

\* Available only with 0...10V output signal (A).  
\*\* Available only with 4...20mA output signal (E).

Please see page B3 or B19 to order 4MA cylinder configuration.

Standard Lengths

Electrical Stroke

inches	mm
2	0051
3	0077
4	0102
5	0127
6	0152
7	0178
8	0203
9	0230
10	0254
11	0280
12	0305
13	0330

inches	mm
15	0381
16	0407
18	0457
20	0508
22	0560
24	0610
26	0661
28	0711
30	0762
32	0813
36	0914
40	1016

inches	mm
42	1067
48	1220
50	1270
60	1524
70	1778
80	2032
90	2286
100	2540
110	2794
120	3048

S32 Cables

Length

5M	BKS-S32M-05
10M	BKS-S32M-10



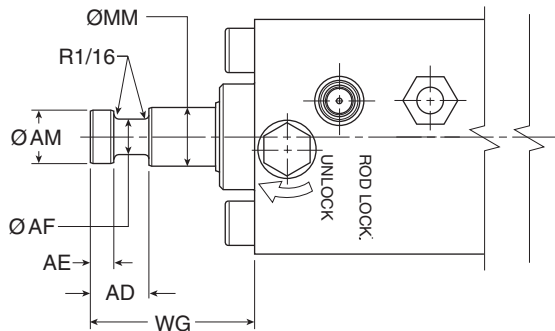
For inventory, lead times, and kit lookup, visit [www.pdnplu.com](http://www.pdnplu.com)



**Parker “Style 55” Piston Rod End**

Rod end flange coupling for Parker 4MA, 4ML and 4MAJ Series cylinders:

- Simplifies alignment
- Reduces assembly time
- Allows full rated pneumatic pressure in push and pull directions
- Available in 5/8" through 1-3/4" piston rod diameters



**Example:** Style 55 Rod End shown on 4MAJ Series cylinder

**How To Order**

Complete Model Number and place a “55” in the Piston Rod End designator position.

Example: 2.00 CJ4MAJU155C 6.000

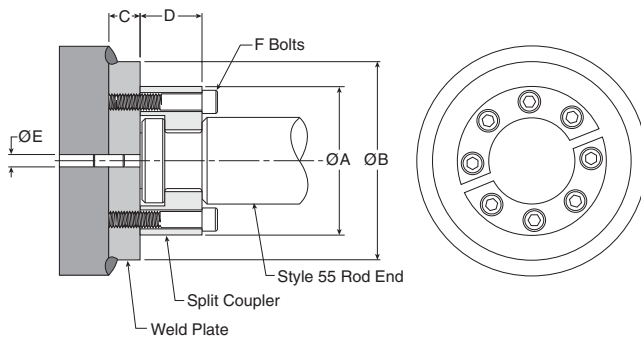
Consult factory for availability of mounting accessories and hardware.

**Style 55 Rod End Dimensions**

Rod dia. MM	AD	AE	AF	AM	WG
5/8	5/8	1/4	3/8	.57	1-3/4
1	1-5/16	3/8	11/16	.95	2-3/8
1-3/8	1-1/16	3/8	7/8	1.32	2-3/4
1-3/4	1-5/16	1/2	1-1/8	1.70	3-1/8

See 4MA or 4MAJ Series sections for more dimensions.

**Split Couplers and Weld Plates**



**⚠ WARNING:** Piston rod separation from the machine member can result in severe personal injury or even death to nearby personnel. The cylinder user must make sure the weld holding the weld plate to the machine is of sufficient quality and size to hold the intended load. The cylinder user must also make sure the bolts holding split coupler to the weld plate are of sufficient strength to hold the intended load and installed in such a way that they will not become loose during the machine's operation.

**NOTE:** Screws are not included with split coupler or weld plate.

**Table 1**  
**Part Numbers and Dimensions**

Rod dia.	A	B	C	D	E	F	Bolt size	Bolt circle	Split coupler part no.	Weld plate part no.
0.625	1.50	2.00	0.50	0.56	0.250	4	#10-24 x .94 LG	1.125	<b>1472340062</b>	<b>1481740062</b>
1.00	2.00	2.50	0.50	0.88	0.250	6	.250-20 x 1.25 LG	1.500	<b>1472340100</b>	<b>1481740100</b>
1.375	2.50	3.00	0.63	1.00	0.250	6	.312-18 x 1.50 LG	2.000	<b>1472340138</b>	<b>1481740138</b>
1.75	3.00	4.00	0.63	1.25	0.250	8	.312-18 x 1.75 LG	2.375	<b>1472340175</b>	<b>1481740175</b>

**NOTE:** All dimensions without a tolerance are reference dimensions.



For inventory, lead time, and kit lookup, visit [www.pdnplu.com](http://www.pdnplu.com)

**Metric Rod Threads**

Standard metric thread sizes for piston rod thread type M.

Rod dia. MM	Styles 4 & 9 KK	Style 8 CC
3/8	M6 x 1.0	M8 x 1.25
1/2	M8 x 1.25	M12 x 1.25
5/8	M10 x 1.5	M12 x 1.5
1	M20 x 1.5	M22 x 1.5
1-3/8	M26 x 1.5	M30 x 2.0
1-3/4	M33 x 2.0	M39 x 2.0

NOTE: All other rod end dimensions are standard per catalog.

**Check Seal Cushions**

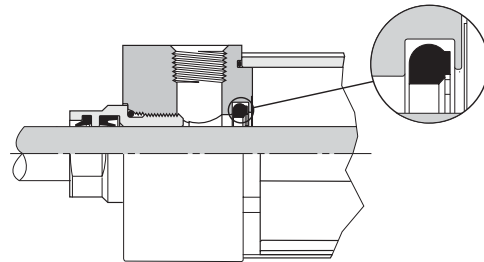
**For Increased Productivity and Maximum Performance**

The check seal cushion is new and different from ordinary cushion designs. It combines the sealing capabilities of a lipseal for efficient capture of air to effectively cushion and to provide check valve action for quick stroke reversal.

The design also provides “floating cushions” to assure cushion repeatability and long life. At the start of the stroke in each direction, the check valve design allows full flow to piston face with a minimum pressure drop for a maximum power stroke.

Additional benefits of the new check seal cushions are increased productivity and top performance for faster cycle time, minimum wear, easy adjustment and low pressure drop.

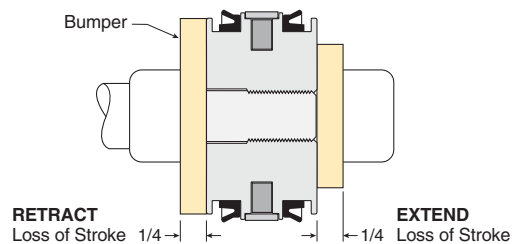
The basic cushion design is available at both ends without change in envelope or mounting dimensions. A captive cushion adjusting needle is supplied for easy, precise adjustment on all bore sizes.



**Bumpers**

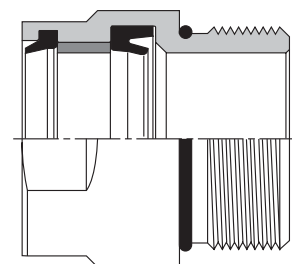
Impact dampening conventional bumpers can be provided on one or both sides of the piston with a 1/4" stroke loss per bumper. This style of bumper is ideal for applications subjected to high speeds where cycle time may discourage the use of cushions.

Available in 1-1/2" - 4" bore sizes for 4MA, 4ML and 4MAJ Series cylinders.



**HI LOAD Gland Assembly**

Applications with inherent side load require a slide package for maximum service life. In some cases, there may be limitations to the size or expense of these additional components. One possible solution may be the use of the optional HI LOAD gland assembly that incorporates a high strength composite bearing for radial load conditions. Extensive testing showed an approximate 50% increase in service life for general applications. Please note that each application is unique and results may vary. Includes seal options for standard, high and low temperature applications with air (4MA) or hydraulic (4ML) service.



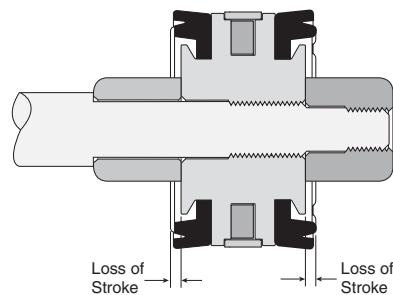
**B**  
 Tie Rod Pneumatic  
 Cylinders  
 4MA  
 Series  
 4MAJ  
 Series  
 2MNR  
 Series  
 ACVB  
 Option  
 LPSO  
 Option  
 P1D  
 Series



For inventory, lead times, and kit lookup, visit [www.pdnplu.com](http://www.pdnplu.com)

### Bumper Seal Option

Impact dampening Bumper Seals are now optional on all 4MA and 4MAJ cylinders from 1-1/2" to 5" bore. The Bumper Seal piston combines the features of low-friction, rounded lipseals and impact-dampening bumpers to provide reduced noise and smoother end-of-stroke deceleration. At pressure greater than 80 PSI, the compressible Buna Nitrile or Fluorocarbon Bumper Seal has minimal effect on stroke loss. When specified, Bumper Seals will be supplied on both ends of the piston, eliminating the need to specify head end or cap end only.



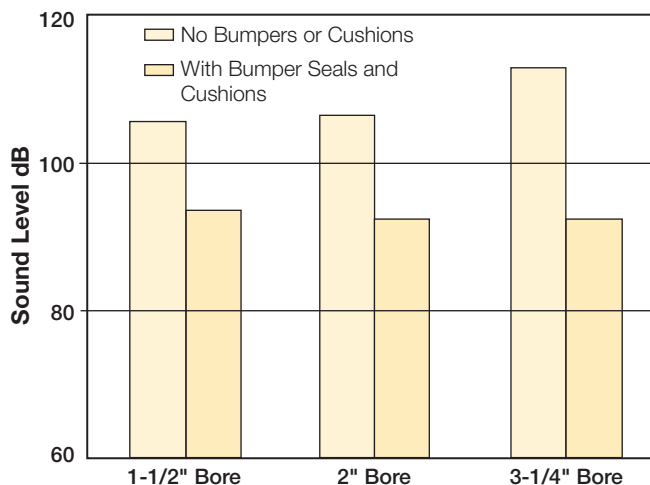
### Summary of Accelerometer Test Results

Bore Size	Piston Type	Cushioning Efficiency (Maximum G's of Deceleration Force Created)	Cushioning Time (ms)
1-1/2"	Standard Piston	13.4	22
	Bumper Seal Piston	5.1	22
2"	Standard Piston	12.6	33
	Bumper Seal Piston	7.8	26
2-1/2"	Standard Piston	12.2	36
	Bumper Seal Piston	5.2	24

### Bumper Seals Reduce Noise

The special profile of the Bumper Seal prevents the piston from noisily banging into the end cap at the end of stroke. Independent testing shows that the Bumper Seal, when combined with cushions, will absorb the final piston inertia and reduce the stroke noise by as much as 20 dB. The Sound Level Comparison graph illustrates the noise-reducing effects of the Bumper Seal piston when combined with cushions.

Impact noise was recorded at a distance of 3 feet from the front of the cylinder, inside a semi-anechoic chamber. Cylinders were operating at 95 PSI.



### Sound Level Comparison

#### Bumper Seals have Minimum Effect on Stroke Length

The accompanying chart depicts typical amounts of overall stroke loss incurred at various system pressures. The amount of stroke loss may vary slightly due to design tolerances of seal size, variance in seal durometer and compression set associated with cylinder wear. To determine the stroke loss at either end of the cylinder, divide the values by two.

Pressure (PSI)	Typical Overall Loss of Stroke (inch) by Bore Size				
	1-1/2"	2"	2-1/2"	3-1/4"	4"
0	0.16	0.13	0.19	0.22	0.22
20	0.12	0.11	0.12	0.18	0.18
40	0.10	0.08	0.09	0.12	0.12
60	0.08	0.07	0.07	0.09	0.09
80	0.06	0.05	0.05	0.06	0.06
100	0.05	0.03	0.02	0.04	0.04



For inventory, lead time, and kit lookup, visit [www.pdnplu.com](http://www.pdnplu.com)

**B**

Tie Rod Pneumatic Cylinders

4MA Series

4MAJ Series

2MNR Series

ACVB Option

LPSO Option

P1D Series

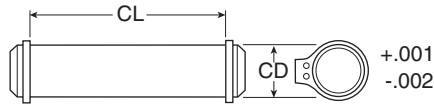
**1-1/2" to 8" Bore Cylinder Accessories**

Rod end accessories can be selected by cylinder rod end thread size from Table A & B below. Mating parts for rod end accessories are listed just to the right of the knuckle or clevis selected. Mounting plates for style MP1 & MP4 cylinder mounts are selected by bore size from Table C.

Rod end thread size	TABLE A			TABLE B			TABLE C		
	Female rod clevis	Eye bracket	Pivot pin	Knuckle	Clevis bracket	Pivot pin	Bore size	For mtg. style MP1 cylinder	For mtg. style MP4 cylinder
7/16-20	1458030044	1458060050	0856640050	1458040044	1458050050	0856640050	1-1/2	1458060050	1458050050
1/2-20	1458030050	1458060050	0856640050	1458040050	1458050050	0856640050	2	1458060050	1458050050
3/4-16	1458030075	1458060075	0856640075	1458040075	1458050075	0856640075	2-1/2	1458060050	1458050050
7/8-14	1458030088	1458060100	0856640100	1458040088	1458050100	0856640100	3-1/4	1458060075	1458050075
1-14	1458030100	1458060100	0856640100	1458040100	1458050100	0856640100	4	1458060075	1458050075
1-1/4-12	1458030125	1458060138	0856640138	1458040125	1458050138	0856640138	5	1458060075	—
1-1/2-12	1458030150	1458060175	0856640175	1458040150	1458050175	0856640175	6	1458060100	—
							8	1458060100	—

**Pivot Pin**

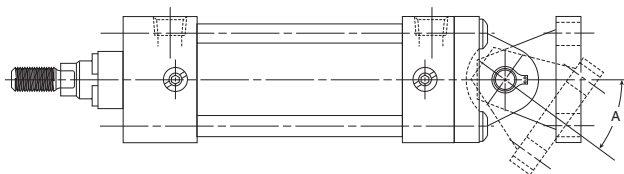
Note: Pivot Pin must be ordered separately for single lug pivot mounting.



Note:

4MA Cylinder Mounting Kits and assembly instructions can be found on page B82. These kits can all be bolted onto cylinders with standard TEF mounts.

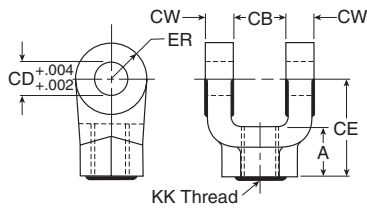
Symbol	0856640044	0856640050	0856640075	0856640100	0856640138	0856640175
CD	7/16	1/2	3/4	1	1-3/8	1-3/4
CL	1-5/16	1-7/8	2-5/8	3-1/8	4-1/8	5-3/16
Shear Cap. (lbs)	6600	8600	19300	34300	65000	105200



**Maximum Pivot Angle for Rear Clevis Mounts (BB Mounts) and Accessories**

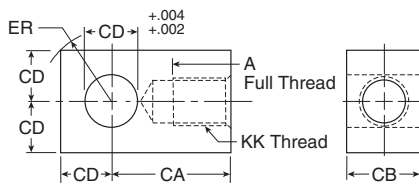
Bore	1-1/2	2	2-1/2	3-1/4	4	5	6	8
Angle A	52	43	29	50	49	45	42	42

**Female Rod Clevis**



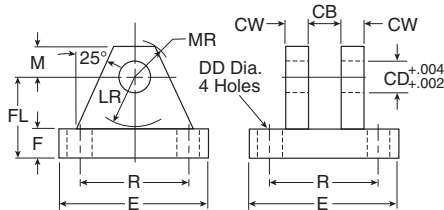
Symbol	1458030044	1458030050	1458030075	1458030088	1458030100	1458030125	1458030150
A	3/4	3/4	1-1/8	1-5/8	1-5/8	2	2-1/4
CB	3/4	3/4	1-1/4	1-1/2	1-1/2	2	2-1/2
CD	1/2	1/2	3/4	1	1	1-3/8	1-3/4
CE	1-1/2	1-1/2	2-1/8	2-15/16	2-15/16	3-3/4	4-1/2
CW	1/2	1/2	5/8	3/4	3/4	1	1-1/4
ER	1/2	1/2	3/4	1	1	1-3/8	1-3/4
KK	7/16-20	1/2-20	3/4-16	7/8-14	1-14	1-1/4-12	1-1/2-12
Load Capacity (lbs)	4250	4900	11200	18800	19500	33500	45600

**Rod Eye Knuckle**



Symbol	1458040044	1458040050	1458040075	1458040088	1458040100	1458040125	1458040150
A	3/4	3/4	1-1/8	1-1/8	1-5/8	2	2-1/4
CA	1-1/2	1-1/2	2-1/16	2-3/8	2-13/16	3-7/16	4
CB	3/4	3/4	1-1/4	1-1/2	1-1/2	2	2-1/2
CD	1/2	1/2	3/4	1	1	1-3/8	1-3/4
ER	23/32	23/32	1-1/16	1-7/16	1-7/16	1-31/32	2-1/2
KK	7/16-20	1/2-20	3/4-16	7/8-14	1-14	1-1/4-12	1-1/2-12
Load Capacity (lbs)	5000	5700	12100	13000	21700	33500	45000

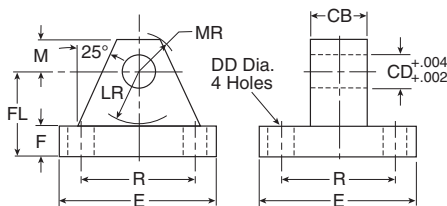
**Clevis Bracket**



\* Wall mount - will not mount directly to rear of cylinder.

Symbol	1458050044	1458050050	1458050075	1458050100	1458050138	1458050175
CB	15/32	3/4	1-1/4	1-1/2	2	2-1/2
CD	7/16	1/2	3/4	1	1-3/8	1-3/4
CW	3/8	1/2	5/8	3/4	1	1-1/4
DD	17/64	13/32	17/32	21/32	21/32	29/32
E	2-1/4	3-1/2	5	6-1/2	7-1/2	9-1/2
F	3/8	1/2	5/8	3/4	7/8	7/8
FL	1	1-1/2	1-7/8	2-1/4	3	3-5/8
LR	5/8	3/4	1-3/16	1-1/2	2	2-3/4
M	3/8	1/2	3/4	1	1-3/8	1-3/4
MR	1/2	5/8	29/32	1-1/4	1-21/32	2-7/32
R	1.75	2.55	3.82	4.95	5.73	7.50
Load Capacity (lbs)	3600	7300	14000	19200	36900	34000

**Mounting Plate & Eye Bracket**



\* Wall mount - will not mount directly to rear of cylinder.

Symbol	1458060031	1458060050	1458060075	1458060100	1458060138	1458060175
CB	15/16	3/4	1-1/4	1-1/2	2	2-1/2
CD	15/16	1/2	3/4	1	1-3/8	1-3/4
DD	17/64	13/32	17/32	21/32	21/32	29/32
E	2-1/4	2-1/2	3-1/2	4-1/2	5	6-1/2
F	3/8	3/8	5/8	7/8	7/8	1-1/8
FL	1	1-1/8	17/8	2-3/8	3	3-3/8
LR	5/8	3/4	1-1/4	1-1/2	2-1/8	2-1/4
M	3/8	1/2	3/4	1	1-3/8	1-3/4
MR	1/2	9/16	7/8	1-1/4	1-5/8	2-1/8
R	1.75	1.63	2.55	3.25	3.82	4.95
Load Capacity (lbs)	1700	4100	10500	20400	21200	49480



For inventory, lead time, and kit lookup, visit [www.pdnplu.com](http://www.pdnplu.com)

B81

**Parker Hannifin Corporation**  
 Pneumatic Division  
 Richland, Michigan  
[www.parker.com/pneumatics](http://www.parker.com/pneumatics)

**Mounting Kit Assembly**

Perform the following steps when installing mounting kits onto 1-1/2" - 5" bore 4MA and 4ML cylinders with the standard mount (TE or TEF).

1. Clean mating parts to remove oil, grease and dirt.
2. Fasteners should be clean, dry and burr free.
3. Brush mounting fastener threads thoroughly with anti-seize lubricant.
4. Follow the appropriate procedure below for the desired mounting.

**Rear Pivot Mounting Kits – Styles BB, BC and BE (Fig. 1)**

Place pivot mount over end cap, lining up the four fastener holes in the end cap with the pivot mounting plate. Note that the pivot mount can be rotated allowing for different cylinder port locations. Secure mounting to cylinder cap (finger tight) using the four fasteners. Torque the fasteners to the specifications in the table below.

**End Angle Mounting Kit – Styles CB (Fig. 2)**

The end angles bolt to the front and rear of the cylinder end caps. The spacer plate\*\* provided is to be assembled at the rod end under the angle plate. Line up the two holes of the spacer plate and angle plate with the two fastener holes in the cylinder head. If 2 different length fasteners are in the kit, use the longer fasteners for the cylinder head end (rod end) mount. Secure (finger tight) using two fasteners. Repeat this assembly at the opposite end (less spacer). Place the assembly with the end angles down on a flat surface and torque the four fasteners to the specifications shown in the table below.

**Flange Mounting Kits – Styles J and H Single and Double Rod Cylinders (Fig. 3)**

Place rectangular flange plate over appropriate end cap. Line up the four holes in the mounting plate with the four fastener holes in the cylinder end cap. Note that the rectangular mounting plate can be rotated to allow for different port locations. Secure the rectangular mounting plate to the end cap (finger tight) using the four fasteners. Then torque the four fasteners to the specifications shown in the table below.

**Side End Lug Mounting Kits – Style G (Fig. 4)**

Attach the two longer lugs with the fasteners provided in the kit to the cylinder head as shown. Attach the two shorter lugs to the cylinder cap in a similar fashion. Place the assembly with the lugs down on a flat surface and torque the four fasteners to the specifications shown in the table below.

Fig. 1 - Pivot Mounting Kit

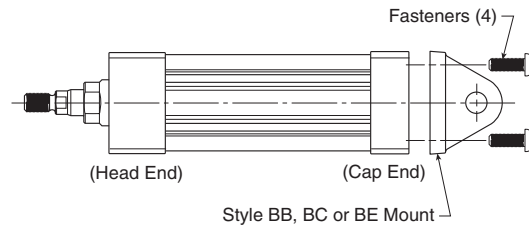


Fig. 2 - End Angle Mounting Kit

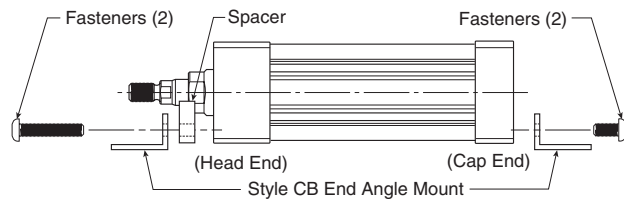


Fig. 3 - Flange Mounting Kit

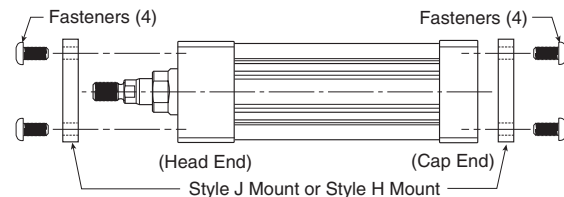
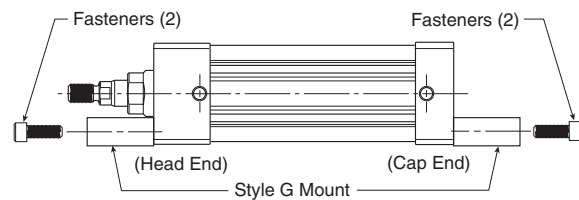


Fig. 4 - Side End Lug Mounting Kit - Style MS7



**Mounting Kits**

Bore Size	J (MF1)	H (MF2)	BB (MP1)	BC (MP2)	BE (MP4)	CB (MS1)	G (MS7)	Kit fastener torque units	
	Head rectangular flange	Cap rectangular flange	Cap fixed clevis	Cap detachable clevis	Cap detachable eye	Side end angles	Side end lug	USA	Metric
	Kit number	Kit number	Kit number	Kit number	Kit number	Kit number	Kit number	inch-lbs	Nm
1-1/2	L079700150	L079700150	L079710150	L079730150	L079720150	L079740150	L079750150	32 - 36	3.6 - 4.1
2	L079700200	L079700200	L079710200	L079730200	L079720200	L079740200	L079750200	72 - 82	8 - 9
2-1/2	L079700250	L079700250	L079710250	L079730250	L079720250	L079740250	L079750250	72 - 82	8 - 9
3-1/4	L079700325	L079700325	L079710325	L079730325	L079720325	L079740325	L079750325	216 - 228	24 - 25.3
4	L079700400	L079700400	L079710400	L079730400	L079720400	L079740400	L079750400	216 - 228	24 - 25.3
5	L079700500	L079700500	L079710500	L079730500	N/A	L079740500	N/A	360 - 372	41 - 42

\*\* Spacer plate not used for 4" bore or double rod cylinders



For inventory, lead times, and kit lookup, visit [www.pdnplu.com](http://www.pdnplu.com)

**Gland Kits (Gland cartridges and rod seals)**

**Pneumatic service only**

Temperatures:

- Nitrile -10°F to 165°F (-23°C to 74°C)
- Fluorocarbon -10°F to 250°F (-23°C to 121°C)

**Servicing the rod gland (Cylinder disassembly is not required)**

Air leakage around the piston rod at the gland area will normally indicate a need to replace the gland cartridge.

The Parker 4MA gland is a unique cartridge design. It is threaded into the cylinder head and all sizes are removable without disturbing the endcap fasteners.

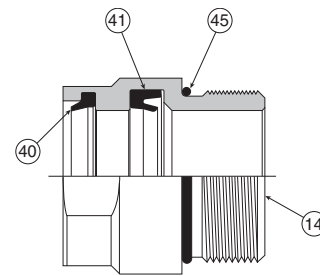
**To remove the old gland cartridge from the cylinder:**

1. Inspect the piston rod to be sure it is free of burrs or other foreign material that would prevent sliding the gland off the rod.
2. Disconnect any attachments to the piston rod end thread.
3. Lubricate the rod with Lube-A-Cyl (included in kit).
4. Unscrew the gland cartridge from the head using the appropriate wrench (see D1 dimension in catalog).
5. Slide the gland cartridge off the piston rod.
6. Verify that the gland-to-head o-ring (#45) is also removed from the head.

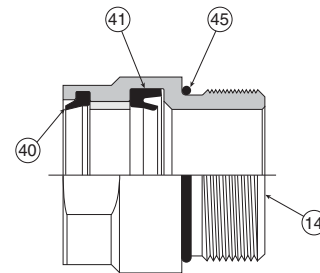
**To install the new gland cartridge onto the cylinder:**

1. Re-inspect the surface of the piston rod for scratches, dents and other surface damage, and repair if necessary.
2. Clean and lubricate the surface of the piston rod with Lube-A-Cyl (included in kit).
3. Lubricate the rod wiper (#40), rod seal (#41), o-ring (#45) and the inside surfaces of the gland cartridge with Lube-A-Cyl.
4. Slide the gland cartridge onto the piston rod, align it with the threads in the head, and tighten (clockwise) until seated firmly against the head.
5. Torque the gland cartridge to the specifications shown below. Tools are available to assist this process (see below).

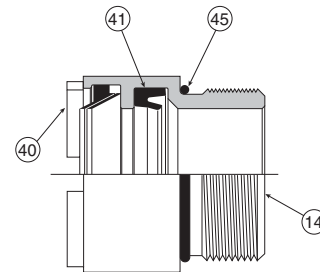
**Note:** Make sure the gland cartridge is sufficiently tight. Failure to do so may result in loosening during operation.



**Standard Rod Gland**



**HI LOAD Rod Gland (includes composite bearing)**



**Metallic Rod Wiper Gland**

Every gland cartridge kit contains 1 each of the following:

Symbol	Description
14	Gland
40	Rod Wiper
41	Rod Seal
45	O-ring - Gland to head

Rod dia.	Standard & HI LOAD gland		Metallic rod wiper gland	
	Gland wrench		Gland wrench	Spanner wrench
5/8	0695800000		0695900000	0116760000
1	0695810000		0695910000	0116760000
1-3/8	0695820000		0695920000	0117030000
1-3/4	0695830000		0695930000	0116770000

Bore size	Rod dia.	Rod no.	Standard rod gland cartridge kit includes 1 each of symbol 14, 40, 41 & 45		HI LOAD rod gland cartridge kit includes 1 each of symbol 14, 40, 41 & 45		Metallic rod wiper gland cartridge kit includes 1 each of symbol 14, 40, 41 & 45		Gland to head torque units	
			Nitrile seals kit number	Fluorocarbon seals kit number	Nitrile seals kit number	Fluorocarbon seals kit number	Nitrile & PUR seals kit number	Fluorocarbon seals kit number	USA ft-lbs	Metric N-m
1-1/2	5/8	1	RG04MA0061	RG04MA0065	RG04MAH061	RG04MAH065	RG04MAM061	RG04MAM065	40 - 45	54 - 61
		2	RG04MA0101	RG04MA0105	RG04MAH101	RG04MAH105	RG04MAM101	RG04MAM105	45 - 50	61 - 68
2	5/8	1	RG04MA0061	RG04MA0065	RG04MAH061	RG04MAH065	RG04MAM061	RG04MAM065	40 - 45	54 - 61
		3	RG04MA0101	RG04MA0105	RG04MAH101	RG04MAH105	RG04MAM101	RG04MAM105	45 - 50	61 - 68
2-1/2	5/8	1	RG04MA0061	RG04MA0065	RG04MAH061	RG04MAH065	RG04MAM061	RG04MAM065	40 - 45	54 - 61
		3	RG04MA0101	RG04MA0105	RG04MAH101	RG04MAH105	RG04MAM101	RG04MAM105	45 - 50	61 - 68
3-1/4	1-3/8	1	RG04MA0101	RG04MA0105	RG04MAH101	RG04MAH105	RG04MAM101	RG04MAM105	45 - 50	61 - 68
		3	RG04MA0131	RG04MA0135	RG04MAH131	RG04MAH135	RG04MAM131	RG04MAM135	75 - 80	102 - 108
4	1-3/8	1	RG04MA0101	RG04MA0105	RG04MAH101	RG04MAH105	RG04MAM101	RG04MAM105	45 - 50	61 - 68
		3	RG04MA0131	RG04MA0135	RG04MAH131	RG04MAH135	RG04MAM131	RG04MAM135	75 - 80	102 - 108
5	1-3/8	1	RG04MA0101	RG04MA0105	RG04MAH101	RG04MAH105	RG04MAM101	RG04MAM105	45 - 50	61 - 68
		3	RG04MA0131	RG04MA0135	RG04MAH131	RG04MAH135	RG04MAM131	RG04MAM135	75 - 80	102 - 108
6	1-3/8	1	RG04MA0131	RG04MA0135	RG04MAH131	RG04MAH135	RG04MAM131	RG04MAM135	75 - 80	102 - 108
		3	RG04MA0171	RG04MA0175	RG04MAH171	RG04MAH175	RG04MAM171	RG04MAM175	90 - 95	122 - 129
8	1-3/8	1	RG04MA0131	RG04MA0135	RG04MAH131	RG04MAH135	RG04MAM131	RG04MAM135	75 - 80	102 - 108
		3	RG04MA0171	RG04MA0175	RG04MAH171	RG04MAH175	RG04MAM171	RG04MAM175	90 - 95	122 - 129

**B**  
 Tie Rod Pneumatic Cylinders  
 4MA Series  
 4MAJ Series  
 2MNR Series  
 ACVB Option  
 LPSO Option  
 PID Series



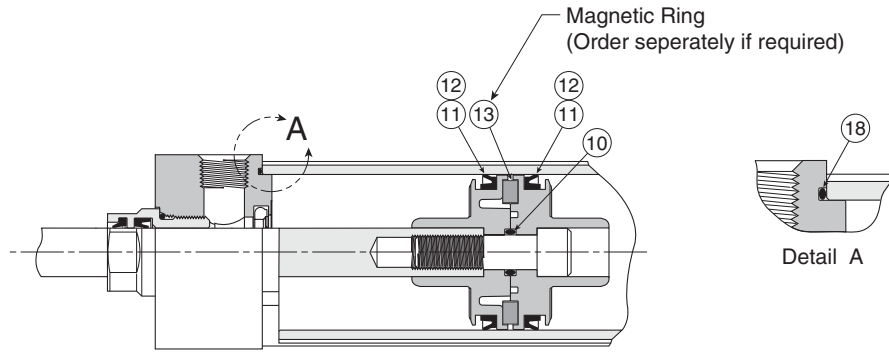
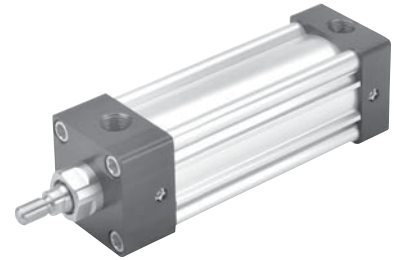
For inventory, lead time, and kit lookup, visit [www.pdnplu.com](http://www.pdnplu.com)

**Piston Seal Kits (Piston and cylinder body seals)**

**Pneumatic service only**

Temperatures:

- Nitrile -10°F to 165°F (-23°C to 74°C)
- Fluorocarbon -10°F to 250°F (-23°C to 121°C)



Composite piston assembly shown above.  
Aluminum piston options available.  
The same piston lipseals fit both piston types.

**Servicing the piston seals – see next page**

**Warning** – The piston rod (or fastener) to piston threaded connection is secured with an anaerobic adhesive that is temperature sensitive. Cylinders specified with all fluorocarbon seals are assembled with an anaerobic adhesive having a maximum operating temperature rating of 250°F (121°C). Cylinders specified with other seal compounds are assembled with an anaerobic adhesive having a maximum operating temperature rating of 165°F (74°C). These temperature limitations are necessary to prevent possible loosening of the threaded connections. Cylinders originally manufactured with Class 1 seals (Nitrile) that will be exposed to ambient temperatures above 165°F (74°C) must be modified for higher temperature service. Contact pdnapps@parker.com immediately and arrange for the piston to rod connection to be properly re-assembled to withstand the higher temperature service and other cylinder changes.

**Note:** the maximum temperature rating for the composite piston is 165°F (74°C).

**Every standard piston seal kit (PK) contains 2 of the following:**

Symbol	Description
11	Piston seal (lipseal)
18	O-ring - cylinder body to head & cap

**Every bumper piston seal kit (BK) contains 2 of the following:**

Symbol	Description
12	Piston seal (bumper seat cushion)
18	O-ring - cylinder body to head & cap

1 tube of Lube-A-Cyl is also included with each PK or BK kit.

Bore size	PK - Piston seal kit, standard lipseals includes 2 each of symbol 11 & 18 Includes wear band (#27) for aluminum pistons and 4" and 5" composite pistons		BK - Piston seal kit, bumper seals includes 2 each of symbol 12 & 18		Magnetic ring (not replaceable for composite piston) Only with nitrile seals part number	Torque units endcap fastener or tie rod	
	Nitrile seals kit number	Fluorocarbon seals kit number	Nitrile seals kit number	Fluorocarbon seals kit number		USA inch-lbs	Metric N-m
1-1/2	PK1504MA01	PK1504MA05	BK01504MA1	BK01504MA5	0865130151	32 - 36	3.6 - 4.1
2	PK2004MA01	PK2004MA05	BK02004MA1	BK02004MA5	0865130200	72 - 82	8 - 9
2-1/2	PK2504MA01	PK2504MA05	BK02504MA1	BK02504MA5	0865130250	72 - 82	8 - 9
3-1/4	PK3254MA01	PK3254MA05	BK03254MA1	BK03254MA5	0865130325	216 - 228	24 - 25.3
4	PK4004MA01	PK4004MA05	BK04004MA1	BK04004MA5	0865130400	216 - 228	24 - 25.3
5	PK5004MA01	PK5004MA05	BK05004MA1	BK05004MA5	0865130500	360 - 372	41 - 42
6	PK6004MA01	PK6004MA05	N/A	N/A	0865130600	420 - 432	48 - 49
8	PK8004MA01	PK8004MA05	N/A	N/A	0865130800	960 - 972	109 - 115



For inventory, lead times, and kit lookup, visit [www.pdnplu.com](http://www.pdnplu.com)



**Parker Lube-A-Cyl...**

Is recommended for use in air cylinders during normal operation, and particularly when servicing and reassembling cylinders. It is a multi-purpose lubricant in grease form that provides lubrication without deteriorating effects on synthetic seals. It produces a thin film which will not blow out with exhaust air. It provides piston, rod and seal lubrication, and has excellent resistance to water and mechanical breakdown with temperature range of -10°F to 350°F (-23°C to 177°C). Lube-A-Cyl is packaged in 1.5 oz. tubes, a sufficient quantity for average size air cylinder. One application should last for a period of 6 to 18 months depending upon service. Order by part number 0761630000.

**Servicing the Piston Seals**

Disassemble the cylinder completely, remove the old seals and clean all the parts. The cylinder bore and piston should then be examined for evidence of scoring. (The light scratch marks usually present on both cylinder bore and piston will generally have no detrimental effects on the performance of the cylinder.)

Apply Parker “Lube-A-Cyl” to O.D. of piston and all grooves. Install one piston Lipseal (sym. # 11 or 12) in the groove nearest the rod. The two “lips” of this seal should face toward the rod end of the piston. **Aluminum and 4" & 5" composite pistons only** – If required, install magnetic ring (sym. #13) in the bottom of the middle groove and then install wear band (sym. #27) in the top of the middle groove.

Coat the inside of the cylinder body with Parker “Lube-A-Cyl” and insert the piston – cap end first – into the cylinder body as shown in detail “2” below.

Next, turn the cylinder body on its side and push the piston and rod assembly through the barrel just far enough to expose the groove for the second Lipseal. (See detail “3” below.) For aluminum pistons, be careful not to move the piston too far so as to expose the wear strip (sym. #27). If the piston should move too far, push the piston and rod assembly completely through the cylinder body and again start the piston from the original end. Now install the second Lipseal (sym. # 11 or 12) in the exposed groove with the two “lips” facing away from the rod and pull the piston into the cylinder body.

The piston and rod are securely locked together with anaerobic adhesive. This threaded connection should only be disassembled or reassembled by factory trained personnel.

**NOTE:** An extreme pressure lubricant (such as molybdenum disulphate) should be used on the tie rod threads and bearing faces to reduce friction and tie rod twist.

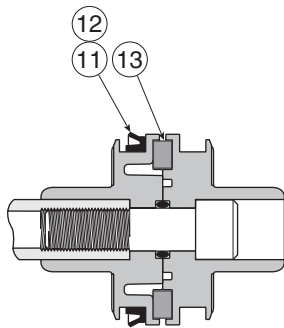
Assemble both cap and head, complete with cylinder body O-Rings (sym. # 18), to each end of the cylinder body. Install end cap fasteners and tighten to appropriate torque, using opposite corner to corner torquing sequence.

In case of a “DD” – center trunnion – mounted cylinder, care must be taken to prevent binding the cylinder body when repositioning the trunnion collar. The proper method of assembling this type of cylinder is as follows:

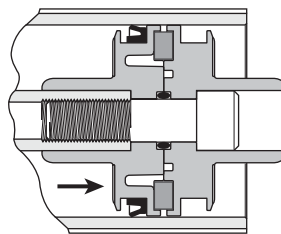
After all the piston seals have been installed on the piston and the piston is in the cylinder body, fit the cap with its O-ring (sym. # 18) in position onto the cylinder body. Then “stud” into the trunnion collar the four tie rods that connect the cap to the trunnion collar. Hand tighten the four tie rod nuts at the cap. Distances from the inner face of the cap to the finished face of the trunnion collar should be made equal at all four tie rods when all four tie rod nuts are in contact with the cap.

When the assembly is ready for final torquing, it may be necessary to adjust the tie rods at the cap when torquing the tie rods at the head in order to position the trunnion collar in its final position.

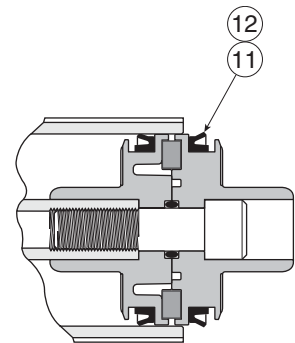
As a check, to be certain the trunnion mount will not interfere with cylinder operation, move the piston and rod assembly by hand to determine whether there is any tendency for the piston to bind at the spot where the trunnion collar is located. If any binding is noticeable, readjust the tie rods.



Detail “1”



Detail “2”



Detail “3”

B
Tie Rod Pneumatic Cylinders
4MA Series
4MAJ Series
2MNR Series
ACVB Option
LPSO Option
PID Series



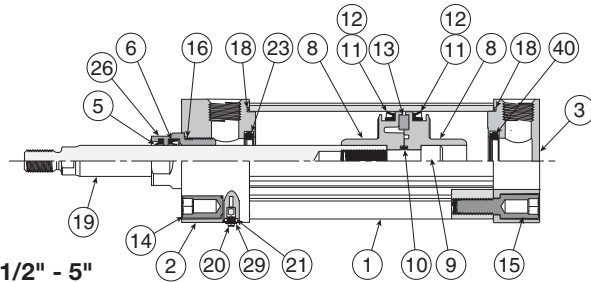
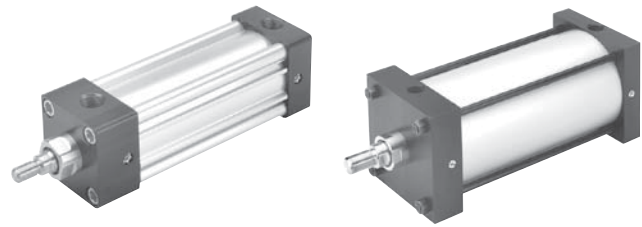
For inventory, lead time, and kit lookup, visit [www.pdnplu.com](http://www.pdnplu.com)

**4MA Complete Cylinder Kits** (All parts to service entire cylinder)

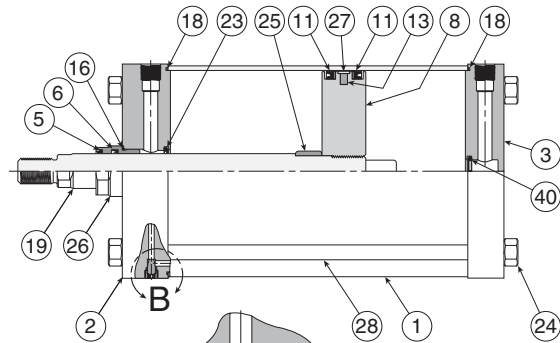
**Pneumatic service only**

Temperatures:

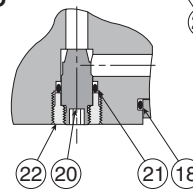
- Nitrile -10°F to 165°F (-23°C to 74°C)
- Fluorocarbon -10°F to 250°F (-23°C to 121°C)



**1-1/2" - 5" Bores**



**6" - 8" Bores**



Detail B

Symbol	Description
1	Cylinder body
2	Head
3	Cap
5	Rod wiper
6	Rod seal
8	Piston (composite or aluminum)
9	Piston fastener (only for composite piston)
10	O-ring - piston fastener to piston
11	Piston seal (lipseal)
12	Piston seal (Bumper seal option)
13	Magnetic ring
14	Head fastener
15	Cap fastener
16	O-ring - gland to head
18	O-ring - cylinder body to head & cap
19	Piston rod
20	Cushion needle valve
21	O-ring - cushion needle valve
22	Cushion needle valve retainer (6" & 8")
23	Cushion check seal - head
24	Tie rod nut (6" & 8" bore or Style DD mounts)
25	Head cushion sleeve
26	Gland
27	Wear band (aluminum and 4" & 5" composite pistons)
28	Tie rod (6" & 8" bore or Style DD mounts)
29	Retaining washer
40	Cushion check seal - cap

**Servicing the complete cylinder**

This kit offers all parts to service an entire 4MA cylinder with the standard rod gland and standard piston lipseals. Kits are available with Nitrile or Fluorocarbon seals.

This kit is a combination of the Standard Gland Kit, Standard Piston Seal Kit, Head Cushion Kit and Cap Cushion Kit. The kits can service cylinders with either the composite or aluminum piston (lipseal). Depending on cylinder configuration, some parts may not be used. Please refer to the pages or bulletins of these individual kits for service instructions.

1 tube of Lube-A-Cyl is also included with each SK kit.

SK - Complete cylinder kit includes 1 each of standard rod gland kit, standard piston seal kit, head cushion kit and cap cushion kit

Bore size	Rod dia.	Rod no.	SK - Complete cylinder kit includes 1 each of standard rod gland kit, standard piston seal kit, head cushion kit and cap cushion kit		Gland to head torque units		Endcap fastener or tie rod torque units	
			Nitrile seals kit number	Fluorocarbon seals kit number	USA ft-lbs	Metric Nm	USA inch-lbs	Metric Nm
1-1/2	5/8	1	SK15104MA1	SK15104MA5	40 - 45	54 - 61	32 - 36	3.6 - 4.1
	1	2	SK15304MA1*	SK15304MA5*	45 - 50	61 - 68		
2	5/8	1	SK20104MA1	SK20104MA5	40 - 45	54 - 61	72 - 82	8 - 9
	1	3	SK20304MA1	SK20304MA5	45 - 50	61 - 68		
2-1/2	5/8	1	SK25104MA1	SK25104MA5	40 - 45	54 - 61	72 - 82	8 - 9
	1	3	SK25304MA1	SK25304MA5	45 - 50	61 - 68		
3-1/4	1	1	SK32104MA1	SK32104MA5	45 - 50	61 - 68	216 - 228	24 - 25.3
	1-3/8	3	SK32304MA1	SK32304MA5	75 - 80	102 - 108		
4	1	1	SK40104MA1	SK40104MA5	45 - 50	61 - 68	216 - 228	24 - 25.3
	1-3/8	3	SK40304MA1	SK40304MA5	75 - 80	102 - 108		
5	1	1	SK50104MA1	SK50104MA5	45 - 50	61 - 68	360 - 372	41 - 42
	1-3/8	3	SK50304MA1	SK50304MA5	75 - 80	102 - 108		
6	1-3/8	1	SK60104MA1	SK60104MA5	75 - 80	102 - 108	420 - 432	48 - 49
	1-3/4	3	SK60304MA1	SK60304MA5	90 - 95	122 - 129		
8	1-3/8	1	SK80104MA1	SK80104MA5	75 - 80	102 - 108	960 - 972	109 - 115
	1-3/4	3	SK80304MA1	SK80304MA5	90 - 95	122 - 129		

\*Does not include Head Cushion Kit (not available)



For inventory, lead times, and kit lookup, visit [www.pdnplu.com](http://www.pdnplu.com)

**4ML Gland Kits (Gland cartridges and rod seals)**

**Hydraulic service (includes TS-2000 rod seal)**

Temperatures:

- Nitrile/Polyurethane (PUR) -10°F to 165°F (-23°C to 74°C)
- Fluorocarbon -10°F to 250°F (-23°C to 121°C)

**Servicing the rod gland (Cylinder disassembly is not required)**

Fluid leakage around the piston rod at the gland area will normally indicate a need to replace the gland cartridge.

The Parker 4ML gland is a unique cartridge design. It is threaded into the cylinder head and all sizes are removable without disturbing the endcap fasteners.

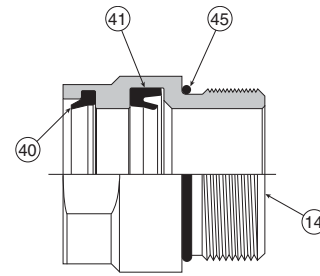
**To remove the old gland cartridge from the cylinder:**

1. Inspect the piston rod to be sure it is free of burrs or other foreign material that would prevent sliding the gland off the rod.
2. Disconnect any attachments to the piston rod end thread.
3. Lubricate the rod with clean light oil.
4. Unscrew the gland cartridge from the head using the appropriate wrench (see D1 dimension in catalog).
5. Slide the gland cartridge off the piston rod.
6. Verify that the gland-to-head o-ring (#45) is also removed from the head.

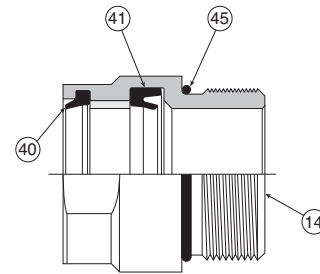
**To install the new gland cartridge onto the cylinder:**

1. Re-inspect the surface of the piston rod for scratches, dents and other surface damage, and repair if necessary.
2. Clean and lubricate the surface of the piston rod with clean light oil.
3. Lubricate the rod wiper (#40), rod seal (#41), o-ring (#45) and the inside surfaces of the gland cartridge with clean light oil.
4. Slide the gland cartridge onto the piston rod, align it with the threads in the head, and tighten (clockwise) until seated firmly against the head.
5. Torque the gland cartridge to the specifications shown below. Tools are available to assist this process (see below).

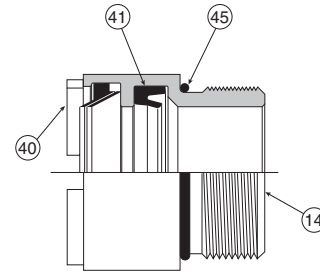
**Note:** Make sure the gland cartridge is sufficiently tight. Failure to do so may result in loosening during operation.



**Standard Rod Gland**



**HI LOAD Rod Gland (includes composite bearing)**



**Metallic Rod Wiper Gland**

Every gland cartridge kit contains 1 each of the following:

Symbol	Description
14	Gland
40	Rod Wiper
41	Rod Seal
45	O-ring - Gland to head

Rod dia.	Standard & HI LOAD gland		Metallic rod wiper gland	
	Gland wrench		Gland wrench	Spanner wrench
5/8	0695800000		0695900000	0116760000
1	0695810000		0695910000	0116760000
1-3/8	0695820000		0695920000	0117030000
1-3/4	0695830000		0695930000	0116770000

Bore Size	Rod Dia.	Rod No.	Standard rod gland cartridge kit includes 1 each of symbol 14, 40, 41 & 45		HI LOAD rod gland cartridge kit includes 1 each of symbol 14, 40, 41 & 45		Metallic rod wiper gland cartridge kit includes 1 each of symbol 14, 40, 41 & 45		Gland to head torque units	
			Nitrile & PUR seals kit number	Fluorocarbon seals kit number	Nitrile & PUR seals kit number	Fluorocarbon seals kit number	Nitrile & PUR seals kit number	Fluorocarbon seals kit number	USA ft-lbs	Metric N-m
1-1/2	5/8	1	RG04ML0061	RG04ML0065	RG04MLH061	RG04MLH065	RG04MLM061	RG04MLM065	40 - 45	54 - 61
	1	2	RG04ML0101	RG04ML0105	RG04MLH101	RG04MLH105	RG04MLM101	RG04MLM105	45 - 50	61 - 68
2	5/8	1	RG04ML0061	RG04ML0065	RG04MLH061	RG04MLH065	RG04MLM061	RG04MLM065	40 - 45	54 - 61
	1	3	RG04ML0101	RG04ML0105	RG04MLH101	RG04MLH105	RG04MLM101	RG04MLM105	45 - 50	61 - 68
2-1/2	5/8	1	RG04ML0061	RG04ML0065	RG04MLH061	RG04MLH065	RG04MLM061	RG04MLM065	40 - 45	54 - 61
	1	3	RG04ML0101	RG04ML0105	RG04MLH101	RG04MLH105	RG04MLM101	RG04MLM105	45 - 50	61 - 68
3-1/4	1	1	RG04ML0101	RG04ML0105	RG04MLH101	RG04MLH105	RG04MLM101	RG04MLM105	45 - 50	61 - 68
	1-3/8	3	RG04ML0131	RG04ML0135	RG04MLH131	RG04MLH135	RG04MLM131	RG04MLM135	75 - 80	102 - 108
4	1	1	RG04ML0101	RG04ML0105	RG04MLH101	RG04MLH105	RG04MLM101	RG04MLM105	45 - 50	61 - 68
	1-3/8	3	RG04ML0131	RG04ML0135	RG04MLH131	RG04MLH135	RG04MLM131	RG04MLM135	75 - 80	102 - 108
5	1	1	RG04ML0101	RG04ML0105	RG04MLH101	RG04MLH105	RG04MLM101	RG04MLM105	45 - 50	61 - 68
	1-3/8	3	RG04ML0131	RG04ML0135	RG04MLH131	RG04MLH135	RG04MLM131	RG04MLM135	75 - 80	102 - 108
6	1-3/8	1	RG04ML0131	RG04ML0135	RG04MLH131	RG04MLH135	RG04MLM131	RG04MLM135	75 - 80	102 - 108
	1-3/4	3	RG04ML0171	RG04ML0175	RG04MLH171	RG04MLH175	RG04MLM171	RG04MLM175	90 - 95	122 - 129
8	1-3/8	1	RG04ML0131	RG04ML0135	RG04MLH131	RG04MLH135	RG04MLM131	RG04MLM135	75 - 80	102 - 108
	1-3/4	3	RG04ML0171	RG04ML0175	RG04MLH171	RG04MLH175	RG04MLM171	RG04MLM175	90 - 95	122 - 129

**B**  
Tie Rod Pneumatic Cylinders  
4MA Series  
4MAJ Series  
2MNR Series  
ACVB Option  
LPSO Option  
PID Series



For inventory, lead time, and kit lookup, visit [www.pdnplu.com](http://www.pdnplu.com)

B87

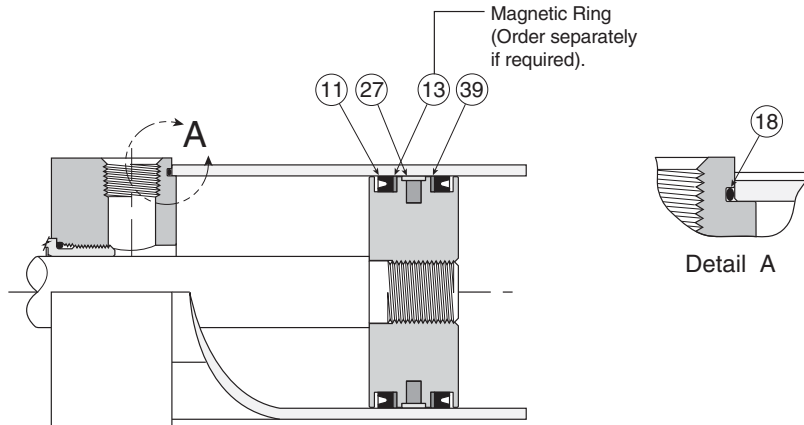
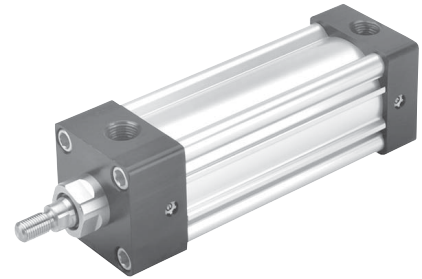
**Parker Hannifin Corporation**  
Pneumatic Division  
Richland, Michigan  
[www.parker.com/pneumatics](http://www.parker.com/pneumatics)

**4ML Piston Seal Kits (Piston and cylinder body seals)**

**Hydraulic service**

Temperatures:

- Nitrile -10°F to 165°F (-23°C to 74°C)
- Fluorocarbon -10°F to 250°F (-23°C to 121°C)



**Servicing the piston seals – see next page**

**Warning –** The piston rod (or fastener) to piston threaded connection is secured with an anaerobic adhesive that is temperature sensitive. Cylinders specified with all fluorocarbon seals are assembled with an anaerobic adhesive having a maximum operating temperature rating of 250°F (121°C). Cylinders specified with other seal compounds are assembled with an anaerobic adhesive having a maximum operating temperature rating of 165°F (74°C). These temperature limitations are necessary to prevent possible loosening of the threaded connections. Cylinders originally manufactured with Class 1 seals (Nitrile) that will be exposed to ambient temperatures above 165°F (74°C) must be modified for higher temperature service. Contact pdnapps@parker.com immediately and arrange for the piston to rod connection to be properly re-assembled to withstand the higher temperature service and other cylinder changes.

Every piston seal kit (PK) contains (2) of symbols 11, 18 and 39, and (1) of symbol 27

Symbol	Description
11	Piston seal (lipseal)
18	O-ring - cylinder body to head & cap
27	Wear band
39	Piston seal backup washer

Bore Size	PK - Piston Seal Kit, Standard Lipseals Includes 2 each of symbol 11, 39 & 18 Wear band (#27) for aluminum piston included		Magnetic Ring Symbol 13 Only with Nitrile Seals	Endcap Fastener or Tie Rod Torque Units	
	Nitrile Seals Kit Number	Fluorocarbon Seals Kit Number	Part Number	USA inch-lbs	Metric N-m
1-1/2	PK1504ML01	PK1504ML05	0865130151	32 - 36	3.6 - 4.1
2	PK2004ML01	PK2004ML05	0865130200	72 - 82	8 - 9
2-1/2	PK2504ML01	PK2504ML05	0865130250	72 - 82	8 - 9
3-1/4	PK3254ML01	PK3254ML05	0865130325	216 - 228	24 - 25.3
4	PK4004ML01	PK4004ML05	0865130400	216 - 228	24 - 25.3
5	PK5004ML01	PK5004ML05	0865130500	360 - 372	41 - 42
6	PK6004ML01	PK6004ML05	0865130600	420 - 432	48 - 49
8	PK8004ML01	PK8004ML05	0865130800	960 - 972	109 - 115

**B**  
 Tie Rod Pneumatic  
 Cylinders  
 4MA  
 Series  
 4MAJ  
 Series  
 2MNR  
 Series  
 ACVB  
 Option  
 LPSO  
 Option  
 P1D  
 Series



For inventory, lead times, and kit lookup, visit [www.pdnplu.com](http://www.pdnplu.com)

**Servicing the Piston Seals**

Disassemble the cylinder completely, remove the old seals and clean all the parts. The cylinder bore and piston should then be examined for evidence of scoring. (The light scratch marks usually present on both cylinder bore and piston will generally have no detrimental effects on the performance of the cylinder.)

Apply clean light oil to O.D. of piston and all grooves. Install one piston Lipseal (sym. # 11) & one Back-Up Washer (sym. #39) in the groove nearest the rod. The two “lips” of the Lipseal (sym. #11) should face toward the rod end of the piston and the Back-Up Washer (sym. #39) should be installed in the same piston groove as shown. If required, install the magnetic ring (sym. # 13) in the bottom of the middle groove. (See detail “1” below) Next, install the wear strip (sym. # 27) in the top of the middle groove – (See detail “2” below).

Coat the inside of the cylinder body with clean light oil and insert the piston – cap end first – into the cylinder body as shown in detail “3” below.

Next, turn the cylinder body on its side and push the piston and rod assembly through the barrel just far enough to expose the piston groove for the second Lipseal. (See detail “4” below.) Be careful not to move the piston too far so as to expose the wear strip (sym. # 27). If the piston should move too far, push the piston and rod assembly completely through the cylinder body and again start the piston from the original end. Now install the second Lipseal (sym. # 11) & Back-Up Washer (sym. #39) in the exposed groove with the two “lips” of the Lipseal (sym. #11) facing away from the rod and the Back-Up Washer (sym. #39) positioned as shown. Then pull the piston into the cylinder body.

The piston and rod are securely locked together with anaerobic adhesive. This threaded connection should only be disassembled or reassembled by factory trained personnel.

**NOTE:** An extreme pressure lubricant (such as molybdenum disulphate) should be used on the tie rod threads and bearing faces to reduce friction and tie rod twist.

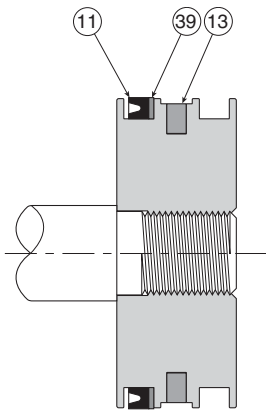
Assemble both cap and head, complete with cylinder body O-Rings (sym. # 18), to each end of the cylinder body. Install end cap fasteners and tighten to appropriate torque, using opposite corner to corner torquing sequence. After screws are torqued, firmly torque the rod gland against the head.

In case of a “DD” – center trunnion – mounted cylinder, care must be taken to prevent binding the cylinder body when repositioning the trunnion collar. The proper method of assembling this type of cylinder is as follows:

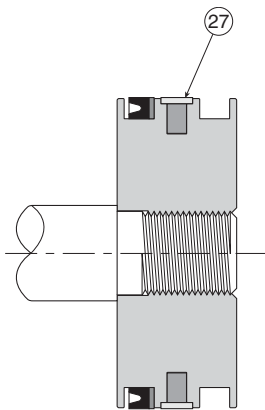
After all the piston seals have been installed on the piston and the piston is in the cylinder body, fit the cap with its O-ring (sym. # 18) in position onto the cylinder body. Then “stud” into the trunnion collar the four tie rods that connect the cap to the trunnion collar. Hand tighten the four tie rod nuts at the cap. Distances from the inner face of the cap to the finished face of the trunnion collar should be made equal at all four tie rods when all four tie rod nuts are in contact with the cap.

When the assembly is ready for final torquing, it may be necessary to adjust the tie rods at the cap when torquing the tie rods at the head in order to position the trunnion collar in its final position.

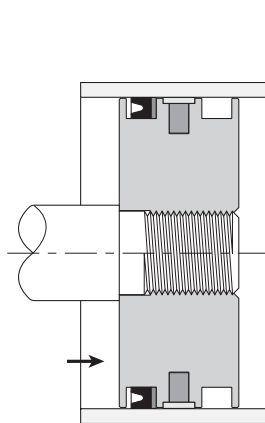
As a check, to be certain the trunnion mount will not interfere with cylinder operation, move the piston and rod assembly by hand to determine whether there is any tendency for the piston to bind at the spot where the trunnion collar is located. If any binding is noticeable, readjust the tie rods.



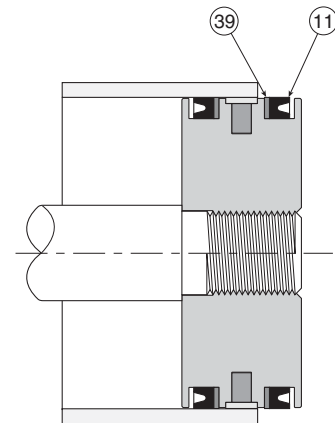
Detail “1”



Detail “2”



Detail “3”



Detail “4”

<b>B</b>	Tie Rod Pneumatic Cylinders
	4MA Series
	4MAJ Series
	2MNR Series
	ACVB Option
	LPSO Option
	P1D Series



For inventory, lead time, and kit lookup, visit [www.pdnplu.com](http://www.pdnplu.com)

**Cylinder Kits (All parts to service entire cylinder)**

**Hydraulic service**

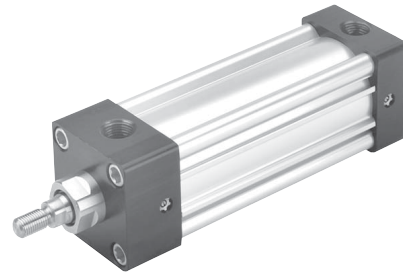
Temperatures:

- Nitrile/Polyurethane (PUR) -10°F to 165°F (-23°C to 74°C)
- Fluorocarbon -10°F to 250°F (-23°C to 121°C)

**Servicing the complete cylinder**

This kit offers all parts to service an entire 4ML cylinder with the standard rod gland and standard piston lipseals. Kits are available with Nitrile/Polyurethane or Fluorocarbon seals.

This kit is a combination of the Standard Gland Kit and Standard Piston Seal Kit. Please refer to the pages or bulletins of these individual kits for service instructions.



**B**  
Tie Rod Pneumatic  
Cylinders

Series  
4MA  
4MAJ  
2MNR  
ACVB  
Option  
LPSO  
Option  
P1D  
Series

Bore size	Rod dia.	Rod no.	SK - Complete cylinder kit includes 1 each of standard rod Gland kit and piston seal kit		Gland to head torque units		Endcap Fastener or Tie Rod Torque Units	
			Nitrile & PUR seals kit number	Fluorocarbon seals kit number	USA ft-lbs	Metric Nm	USA inch-lbs	Metric Nm
1-1/2	5/8	1	<b>SK15104ML1</b>	<b>SK15104ML5</b>	40 - 45	54 - 61	32 - 36	3.6 - 4.1
	1	2	<b>SK15304ML1</b>	<b>SK15304ML5</b>	45 - 50	61 - 68		
2	5/8	1	<b>SK20104ML1</b>	<b>SK20104ML5</b>	40 - 45	54 - 61	72 - 82	8 - 9
	1	3	<b>SK20304ML1</b>	<b>SK20304ML5</b>	45 - 50	61 - 68		
2-1/2	5/8	1	<b>SK25104ML1</b>	<b>SK25104ML5</b>	40 - 45	54 - 61	72 - 82	8 - 9
	1	3	<b>SK25304ML1</b>	<b>SK25304ML5</b>	45 - 50	61 - 68		
3-1/4	1	1	<b>SK32104ML1</b>	<b>SK32104ML5</b>	45 - 50	61 - 68	216 - 228	24 - 25.3
	1-3/8	3	<b>SK32304ML1</b>	<b>SK32304ML5</b>	75 - 80	102 - 108		
4	1	1	<b>SK40104ML1</b>	<b>SK40104ML5</b>	45 - 50	61 - 68	216 - 228	24 - 25.3
	1-3/8	3	<b>SK40304ML1</b>	<b>SK40304ML5</b>	75 - 80	102 - 108		
5	1	1	<b>SK50104ML1</b>	<b>SK50104ML5</b>	45 - 50	61 - 68	360 - 372	41 - 42
	1-3/8	3	<b>SK50304ML1</b>	<b>SK50304ML5</b>	75 - 80	102 - 108		
6	1-3/8	1	<b>SK60104ML1</b>	<b>SK60104ML5</b>	75 - 80	102 - 108	420 - 432	48 - 49
	1-3/4	3	<b>SK60304ML1</b>	<b>SK60304ML5</b>	90 - 95	122 - 129		
8	1-3/8	1	<b>SK80104ML1</b>	<b>SK80104ML5</b>	75 - 80	102 - 108	960 - 972	109 - 115
	1-3/4	3	<b>SK80304ML1</b>	<b>SK80304ML5</b>	90 - 95	122 - 129		



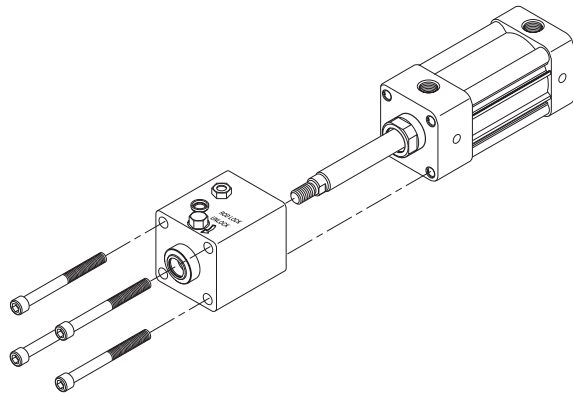
For inventory, lead times, and kit lookup, visit [www.pdnplu.com](http://www.pdnplu.com)

B90

**Parker Hannifin Corporation**  
Pneumatic Division  
Richland, Michigan  
[www.parker.com/pneumatics](http://www.parker.com/pneumatics)

**Rod Lock Removal and Re-assembly**

**1-1/2" to 5" Bores**



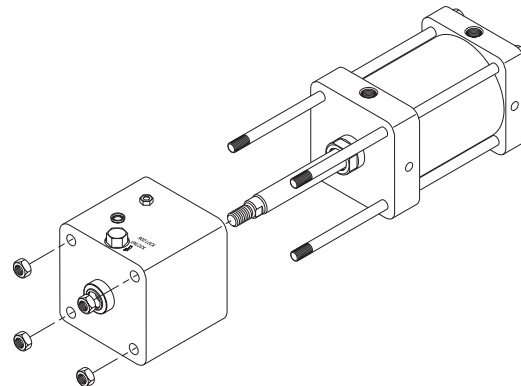
To **remove** the rod lock from the 4MAJ cylinder in order to service the base 4MAJ cylinder, please perform the following steps:

1. Remove the 4MAJ cylinder from the application to a serviceable area.
2. Using a corner-to-corner sequence, loosen the four SHCS fasteners (1-1/2" to 5" bores) or tie rod nuts (6" to 8" bores and all Style DD mounts (NFPA MT4) at the rod lock face and remove them from the rod lock. Please note that the tie rod nuts for 6" to 8" bores and all Style DD mounts are also used to assemble the base cylinder.
3. Apply a minimum of 60 PSI air pressure to the rod lock port, or apply the appropriate amount of torque to the manual override shaft, in order to release the rod lock from the piston rod.
4. Carefully slide the rod lock off the piston rod and away from the base cylinder. The rod lock is piloted and sealed to the gland OD, so some force may be required.
5. Particularly at larger bores, the rod lock can be heavy. Please remove the rod lock from the piston rod and follow all necessary safety precautions.

**SHCS Fastener Torque or Tie Rod torque**

Bore size	inch-lbs	Nm
1-1/2	32-36	3.6-4.1
2	72-82	8-9
2-1/2	72-82	8-9
3-1/4	216-228	24-25.3
4	216-228	24-25.3
5	360-372	41-42
6	420-432	48-49
8	960-972	109-115

**6" to 8" Bores and all Style DD Mounts (NFPA MT4)**



To **re-assemble** the rod lock to the base 4MAJ cylinder, please perform the following steps:

1. Remove all dirt and debris from the mating features of the rod lock, base cylinder, fasteners (or nuts) and threads.
2. Apply a minimum of 60 PSI air pressure to the rod lock port, or apply the appropriate amount of torque to the manual override shaft, in order to open the rod lock.
3. Carefully slide the rod lock onto the piston rod and toward the base cylinder. The rod lock is piloted and sealed to the gland OD, so some force may be required. Press the rod lock to the head face as close as possible, avoiding damage to the rod lock o-ring that seals the gland OD.
4. Using a corner-to-corner sequence, install and tighten, to approximately 75% of final torque specifications, the SHCS fasteners (1-1/2" to 5" bores) or tie rod nuts (6" to 8" bores and all Style DD mounts (NFPA MT4)) at the rod lock face. See torque specification table below.
5. Using a calibrated torque wrench, tighten the fasteners or nuts to the final torque specification using the same corner-to-corner sequence.
6. Remove the air pressure from the rod lock port or remove the torque from the manual override shaft to return the rod lock to the locked state.

**The rod lock units are not field-repairable and must be returned to the Pneumatic Division for any repairs. Please contact pdnapps@parker.com for any assistance.**

<b>B</b>
Tie Rod Pneumatic Cylinders
4MA Series
4MAJ Series
2MNR Series
ACVB Option
LPSO Option
P1D Series



For inventory, lead time, and kit lookup, visit [www.pdnplu.com](http://www.pdnplu.com)

Features

2MNR Series – 1-1/2" to 4" Bore Size

<b>B</b>	Tie Rod Pneumatic Cylinders
	Series
4MA Series	4MAJ Series
2MNR Series	ACVB Option
LPSO Option	P1D Series

**MULTIPLE PISTON RODS**

Three hard-chrome plated and polished piston rods provide stability and strength for higher bearing support. Precision machining provides precise fit for antirotation.

**RETAINER**

Retainer is easily removed for access to rod gland assemblies.

**CHECK SEAL CUSHION**

Molded urethane cushion combines the sealing capabilities of a lipseal for effective cushioning with check valve action for quick stroke reversal. "Floating" cushions assure cushion repeatability and long life.

**ROUNDED LIP PISTON SEALS**

Carboxylated nitrile w/PTFE seals glide over lubricant film instead of scraping it off.

**TOOLING PLATE**

Cold rolled carbon steel tooling plate with corrosion-resistant finish is easily removable for maintenance.

**CUSHION NEEDLE VALVES**

Adjustable captive design makes precise adjustment quick and easy. Can be adjusted while cylinder is under pressure.

**CYLINDER BODY**

Lightweight anodized aluminum body is wear resistant. The smooth extruded design eliminates areas for contamination.

**PISTON AND WEAR BAND**

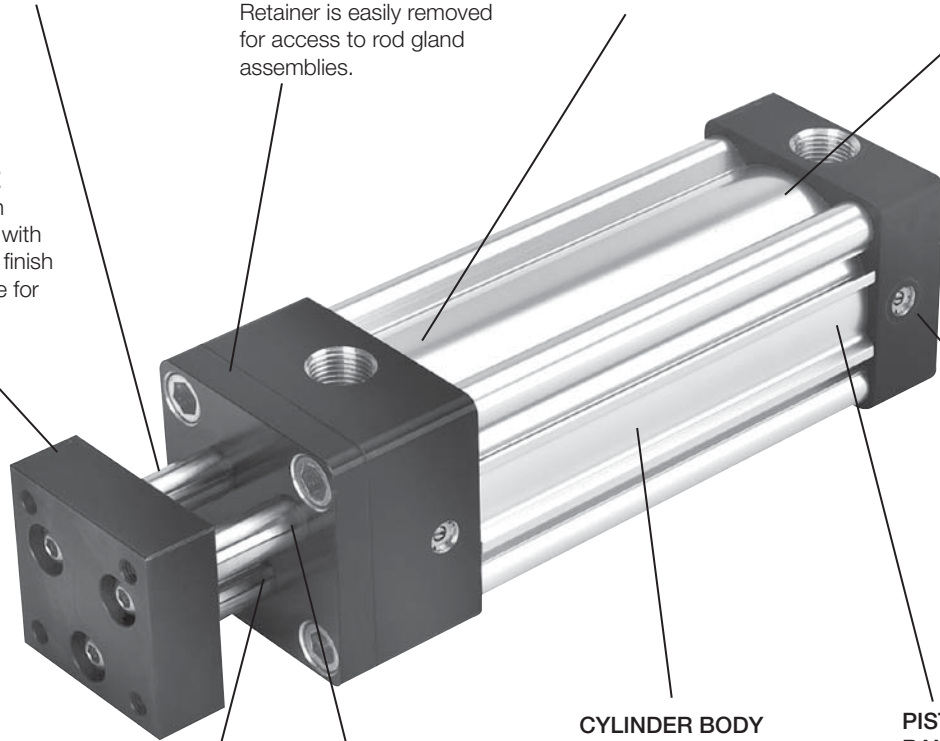
Aluminum lightweight piston with nylon wear band (not shown) eliminates metal-to-metal contact to extend cylinder life. Formed, shaped wear band makes installation and repair easier than regular wear strip.

**ROD SEAL/WIPER**

Combination rod seal and rod wiper, available in either nitrile or fluorocarbon, is inserted into the bearing, creating a rod gland. Completely self-compensating for zero leakage at all pressures.

**ROD BEARING**

Permanently lubricated sintered bronze bearing provides excellent performance in nonlube applications. Bearings are easily removed for service.



For inventory, lead times, and kit lookup, visit [www.pdnplu.com](http://www.pdnplu.com)

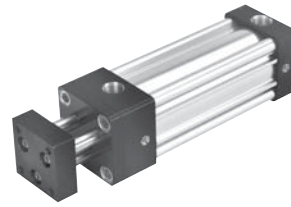
B92

**Parker Hannifin Corporation**  
Pneumatic Division  
Richland, Michigan  
[www.parker.com/pneumatics](http://www.parker.com/pneumatics)



**Features**

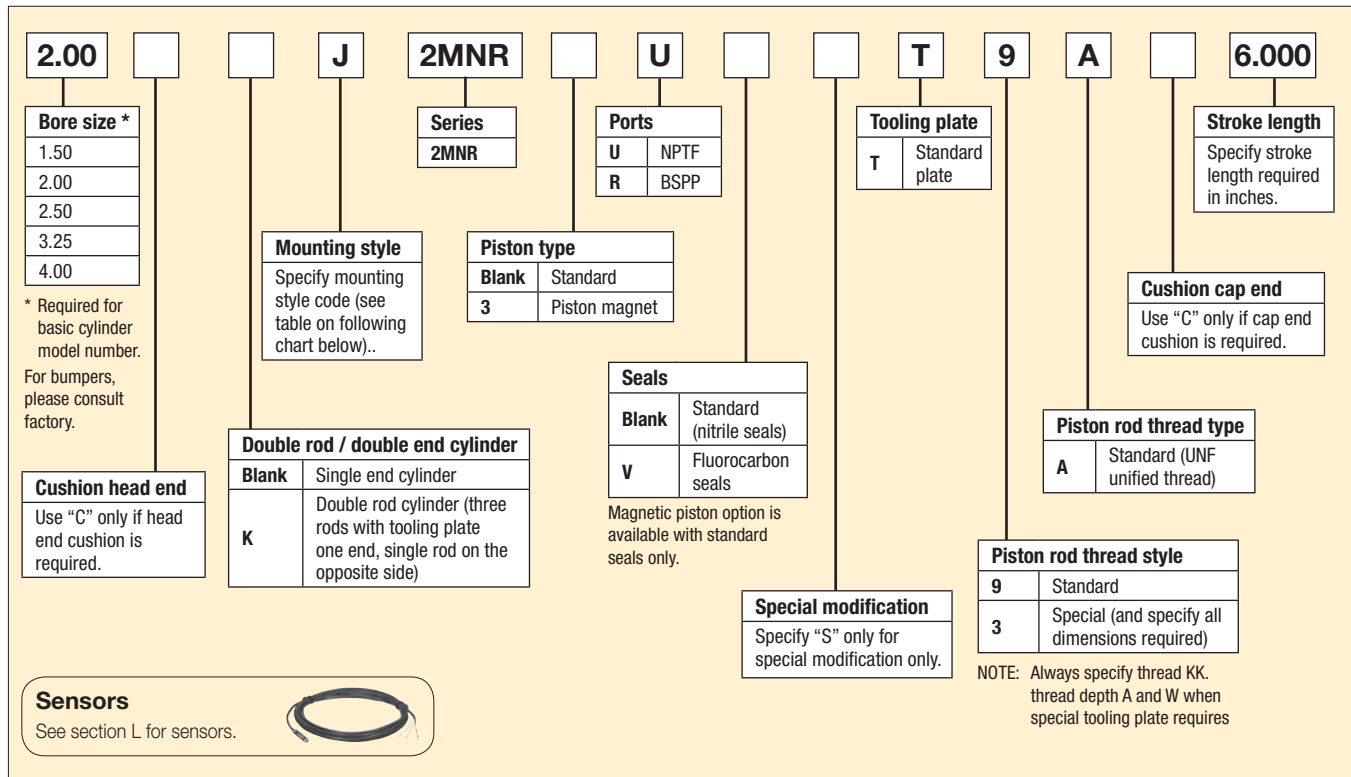
- NFPA Interchangeable
- Bore sizes: 1-1/2 to 4 inches
- Single end or double end designs
- Mounting styles: 9 NFPA standard
- Mounts plus 1 base bar style
- Non-rotating, multi-rod design
- Strokes: available in any practical stroke length
- Cushions: optional at either end or both ends of stroke
- Caustic washdown version available



**Operating information**

Operating pressure: maximum air service	250 PSIG (17 bar)
Temperature range – Standard seals	-10°F to 165°F (-23°C to 73°C)
Fluorocarbon seals	-20°F to 250°F (-29°C to 121°C)
Filtration requirements:	40 micron, dry filtered air

**Ordering information**



**Cylinder mounting styles**

Mounting style code	NFPA style	Mounting description
T	MX0	No mount (basic)
TC	MX2	Tie rods extended cap end
F	MS4	Side tapped
BB †	MP1	Cap Fixed Clevis
BC †	MP2	Cap Detachable Clevis
BE †	MP4	Detachable Pivot Eye
H †	MF2	Cap Rectangular Flange
J †	MF1	Head Rectangular Flange
TE	MX5	Sleeve Nut (Cap End Only)
NB	Non NFPA Style	Base Bar

† Mounting styles with asterisks can be ordered assembled to the cylinder or as a basic (T) no-mount cylinder.

**How to Order Parker 2MNR Series Cylinders with Sensors:**

Sensors are not mounted to the cylinder prior to shipment.

When ordering a cylinder to accommodate a sensor:

1. Derive a proper model number as shown in the table above.
2. Place a "3" in the piston column of the model number.
3. Order appropriate brackets and sensor as separate line items. See Section L for specifications and part numbers.

**Example:** For cylinder prepared for sensor  
2.00CJ2MNR3UT9AC 6.000

**For ordering purposes, when special options or common modifications are requested, the factory will assign a sequential part number in place of the model number.**



For inventory, lead time, and kit lookup, visit [www.pdnplu.com](http://www.pdnplu.com)

**2MNR Mounting Styles**

Mounting style	NFPA mounting	Description	Bore size	Mounting style	NFPA mounting	Description	Bore size
T	MX0	Basic Mount	1-1/2 - 4	BC	MP2	Cap Detachable Clevis	1-1/2 - 4
TC	MX2	Tie Rod Extended Cap End	1-1/2 - 4	BB	MP1	Cap Fixed Clevis	1-1/2 - 4
TE	MX5	Sleeve Nut (Cap end only)	1-1/2 - 4	BE	MP4	Detachable Pivot Eye	1-1/2 - 4
F	MS4	Side Tap )	1-1/2 - 4	NB		Base Bar	1-1/2 - 4
J	MF1	Head Rectangular Flange	1-1/2 - 4	K		Double Rod	1-1/2 - 4
H	MF2	Cap Rectangular Flange	1-1/2 - 4				

**B**  
Tie Rod Pneumatic Cylinders

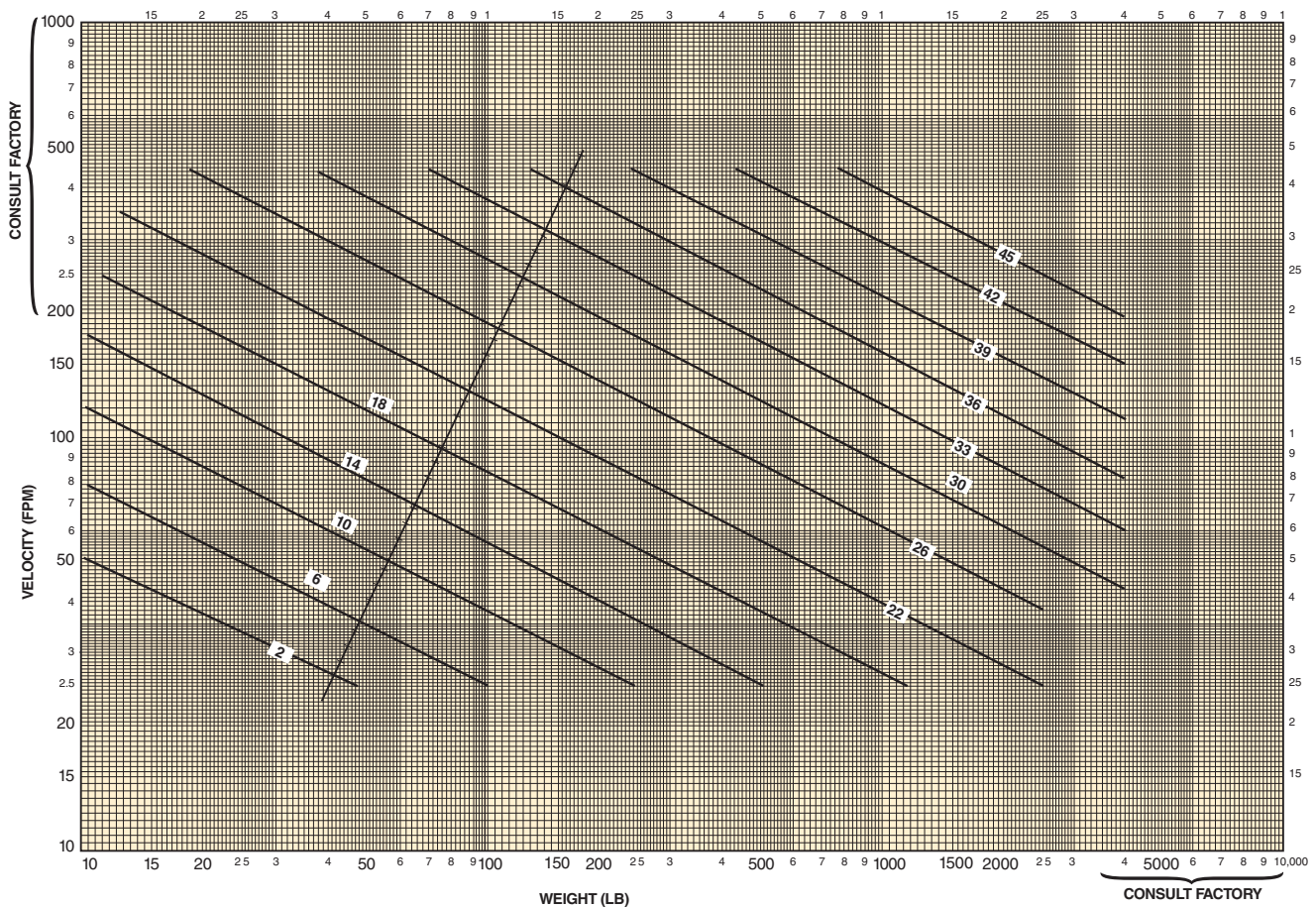
4MA Series  
4MAJ Series  
2MNR Series  
ACVB Option  
LPSO Option  
P1D Series



For inventory, lead times, and kit lookup, visit [www.pdnplu.com](http://www.pdnplu.com)

**Air Cylinder Cushion Ratings**

Bore size	Single ended cylinders and double ended cylinders – multi-rod both ends			Double ended cylinders – single rod one end		
	Cylinder end	Rating with no back pressure	Rating with back pressure	Cylinder end	Rating with no back pressure	Rating with back pressure
1-1/2"	Cap	12	17	Single Rod	7	12
	Rod	6	11	Triple Rod	6	11
2"	Cap	14	20	Single Rod	11	16
	Rod	10	14	Triple Rod	10	14
2-1/2"	Cap	17	23	Single Rod	12	18
	Rod	11	15	Triple Rod	11	15
3-1/4"	Cap	21	26	Single Rod	15	20
	Rod	15	20	Triple Rod	15	20
4"	Cap	23	28	Single Rod	17	23
	Rod	17	23	Triple Rod	17	23



**B**

Tie Rod Pneumatic Cylinders

4MA Series

4MAJ Series

2MNR Series

ACVB Option

LPSO Option

P1D Series



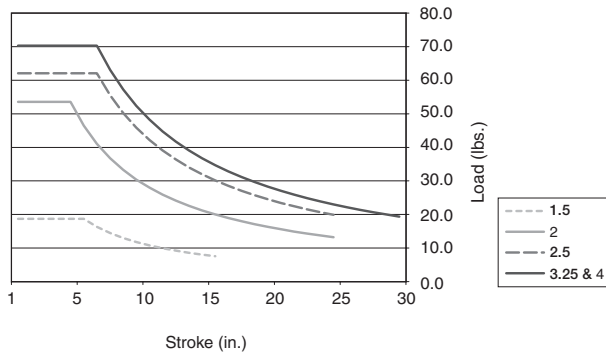
For inventory, lead time, and kit lookup, visit [www.pdnplu.com](http://www.pdnplu.com)

B95

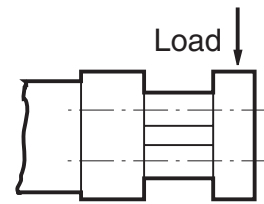
**Parker Hannifin Corporation**  
 Pneumatic Division  
 Richland, Michigan  
[www.parker.com/pneumatics](http://www.parker.com/pneumatics)

**Loading Information**

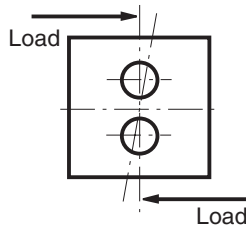
**Side Load Versus Stroke**



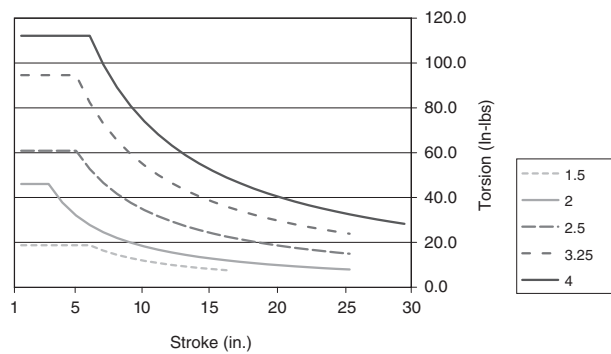
**Side Load**



**Torsional Load**



**Torsional Load Versus Stroke**



**Theoretical Extend and Retract Forces in Pounds**

Bore Size	Movement	Effective area (in <sup>2</sup> )	Pressure (PSI)								Cu. ft. of displacement per inch of stroke
			20	40	60	80	100	150	200	250	
1-1/2"	Extend	1.767	35	71	106	141	177	265	353	442	0.00102
	Retract	1.537	31	61	92	123	154	231	307	384	0.00089
2"	Extend	3.142	63	126	188	251	314	471	628	785	0.00182
	Retract	2.553	51	102	153	204	255	383	511	638	0.00148
2-1/2"	Extend	4.909	98	196	295	393	491	736	982	1227	0.00284
	Retract	3.988	80	160	239	319	399	598	798	997	0.00231
3-1/4"	Extend	8.296	166	332	498	664	830	1244	1659	2074	0.00480
	Retract	7.375	148	295	443	590	738	1106	1475	1844	0.00427
4"	Extend	12.566	251	503	754	1005	1257	1885	2513	3142	0.00727
	Retract	11.646	233	466	699	932	1165	1747	2329	2911	0.00674

**Double Rod Extend Forces – Single Rod Style**

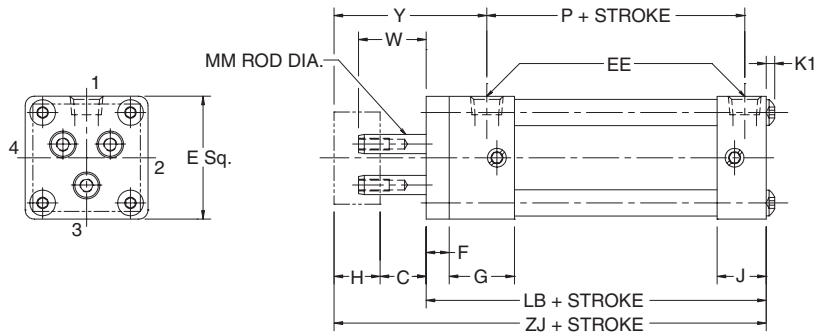
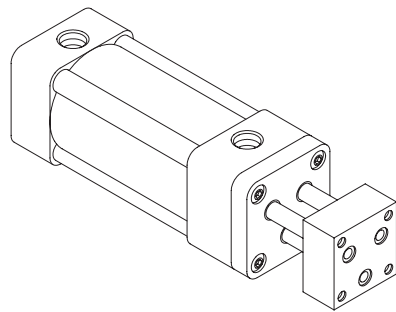
Bore Size	Rod Size	Effective area (in <sup>2</sup> )	Pressure (PSI)								Cu. ft. of displacement per inch of stroke
			20	40	60	80	100	150	200	250	
1-1/2"	5/8"	1.460	29	58	88	117	146	219	292	365	0.00085
2"	5/8"	2.835	57	113	170	227	283	425	567	709	0.00164
2-1/2"	5/8"	4.602	92	184	276	368	460	690	920	1150	0.00266
3-1/4"	1"	7.510	150	300	451	601	751	1127	1502	1878	0.00435
4"	1"	11.781	236	471	707	942	1178	1767	2356	2945	0.00682



For inventory, lead times, and kit lookup, visit [www.pdnplu.com](http://www.pdnplu.com)

**Dimensional Data**

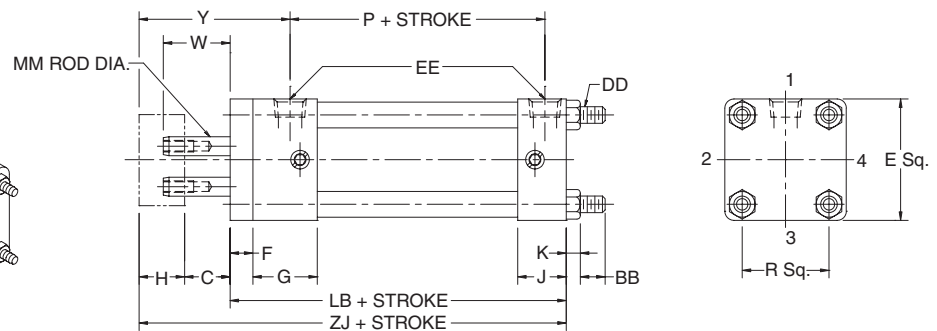
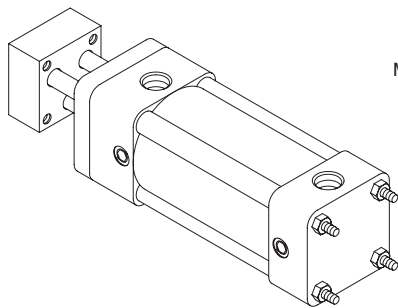
**Basic Single End – Style T (NFPA MX0)**



**Style T and Dimensions**

Bore	Rod dia. mm	C	E	EE (NPTF)	F	G	H	J	K1	W	Y	Add stroke		
												LB	P	ZJ
1-1/2	8mm	3/4	2	1/4	3/8	1-7/16	3/4	15/16	1/8	1.10	2-3/4	4	2-5/16	5-1/2
2	12mm	3/4	2-1/2	1/4	3/8	1-7/16	3/4	15/16	5/32	1.10	2-3/4	4	2-5/16	5-1/2
2-1/2	16mm	3/4	3	3/8	3/8	1-7/16	1	15/16	5/32	1.35	3-1/16	4-1/8	2-3/8	5-7/8
3-1/4	16mm	3/4	3-3/4	1/2	3/8	1-11/16	1	1-3/16	3/16	1.10	3-7/16	4-7/8	2-5/8	6-5/8
4	16mm	3/4	4-1/2	1/2	3/8	1-11/16	1	1-3/16	3/16	1.10	3-7/16	4-7/8	2-5/8	6-5/8

**Tie Rods Extend Cap End – Style TC**



**Style TC and Dimensions**

Bore	Rod dia. mm	BB	C	DD	E	EE (NPTF)	F	G	H	J	K	R	W	Y	Add stroke		
															LB	P	ZJ
1-1/2	8mm	1	3/4	1/4-28	2	1/4	3/8	1-7/16	3/4	15-16	1/4	1.43	1.10	2-3/4	4	2-5/16	5-1/2
2	12mm	1-1/8	3/4	5/16-24	2-1/2	1/4	3/8	1-7/16	3/4	15-16	5/16	1.84	1.10	2-3/4	4	2-5/16	5-1/2
2-1/2	16mm	1-1/8	3/4	5/16-24	3	3/8	3/8	1-7/16	1	15-16	5/16	2.19	1.35	3-1/16	4-1/8	2-3/8	5-7/8
3-1/4	16mm	1-3/8	3/4	3/8-24	3-3/4	1/2	5/8	1-11/16	1	1-3/16	3/8	2.76	1.10	3-7/16	4-7/8	2-5/8	6-5/8
4	16mm	1-3/8	3/4	3/8-24	4-1/2	1/2	5/8	1-11/16	1	1-3/16	3/8	3.32	1.10	3-7/16	4-7/8	2-5/8	6-5/8

**B**  
Tie Rod Pneumatic Cylinders  
4MA Series  
4MAJ Series  
2MNR Series  
ACVB Option  
LPSO Option  
PID Series



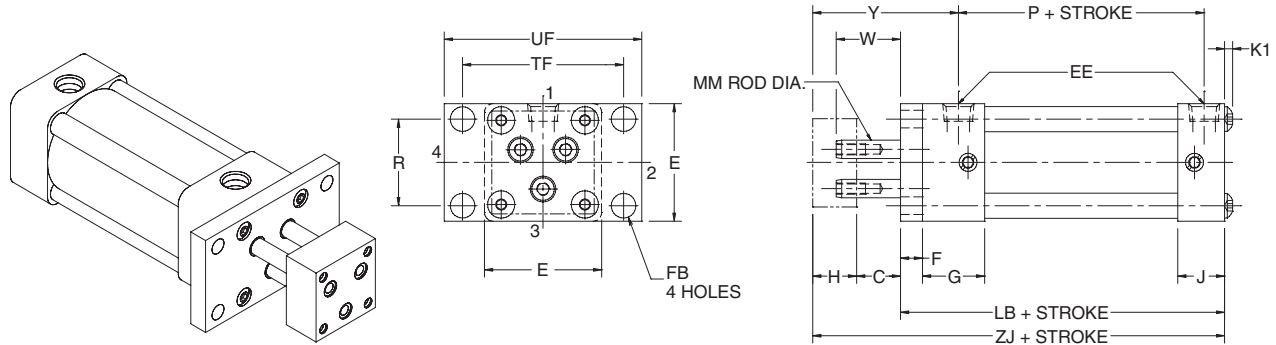
For inventory, lead time, and kit lookup, visit [www.pdnplu.com](http://www.pdnplu.com)

B97

**Parker Hannifin Corporation**  
Pneumatic Division  
Richland, Michigan  
[www.parker.com/pneumatics](http://www.parker.com/pneumatics)

**Dimensional Data**

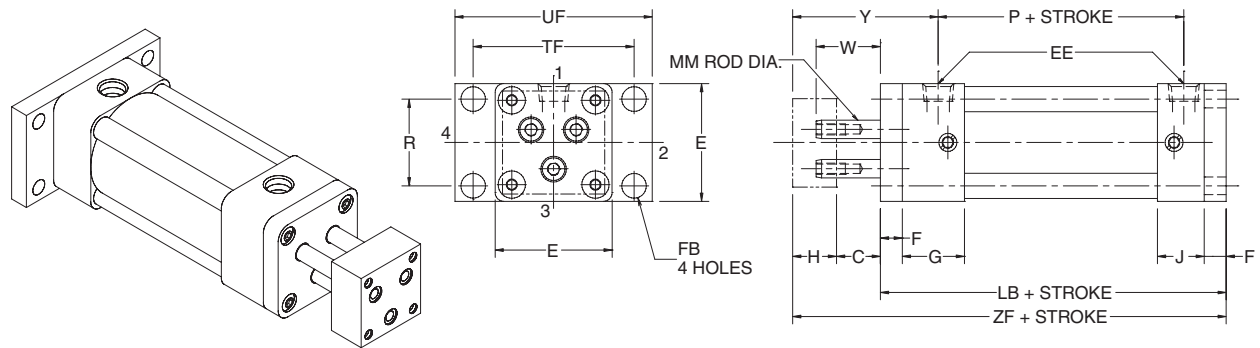
**Head Rectangular Flange – Style J (NFPA MF1)**



**Style J and Dimensions**

Bore	Rod dia. mm	C	E	EE (NPTF)	F	FB	G	H	J	K1	R	TF	UF	W	Y	Add stroke		
																LB	P	ZJ
1-1/2	8mm	3/4	2	1/4	3/8	5/16	1-7/16	3/4	15/16	1/8	1.43	2-3/4	3-3/8	1.10	2-3/4	4	2-5/16	5-1/2
2	12mm	3/4	2-1/2	1/4	3/8	3/8	1-7/16	3/4	15/16	5/32	1.84	3-3/8	4-1/8	1.10	2-3/4	4	2-5/16	5-1/2
2-1/2	16mm	3/4	3	3/8	3/8	3/8	1-7/16	1	15/16	5/32	2.19	3-7/8	4-5/8	1.35	3-1/16	4-1/8	2-3/8	5-7/8
3-1/4	16mm	3/4	3-3/4	1/2	3/8	7/16	1-11/16	1	1-3/16	3/16	2.76	4-11/16	5-1/2	1.10	3-7/16	4-7/8	2-5/8	6-5/8
4	16mm	3/4	4-1/2	1/2	3/8	7/16	1-11/16	1	1-3/16	3/16	3.32	5-7/16	6-1/4	1.10	3-7/16	4-7/8	2-5/8	6-5/8

**Cap Rectangular Flange – Style H (NFPA MF2)**



**Style H and Dimensions**

Bore	Rod dia. mm	C	E	EE (NPTF)	F	FB	G	H	J	R	TF	UF	W	Y	Add stroke		
															LB	P	ZJ
1-1/2	8mm	3/4	2	1/4	3/8	5/16	1-7/16	3/4	15-16	1.43	2-3/4	3-3/8	1.10	2-3/4	4-3/8	2-5/16	5-7/8
2	12mm	3/4	2-1/2	1/4	3/8	3/8	1-7/16	3/4	15-16	1.84	3-3/8	4-1/8	1.10	2-3/4	4-3/8	2-5/16	5-7/8
2-1/2	16mm	3/4	3	3/8	3/8	3/8	1-7/16	1	15-16	2.19	3-7/8	4-5/8	1.35	3-1/16	4-1/2	2-3/8	6-1/4
3-1/4	16mm	3/4	3-3/4	1/2	5/8	7/16	1-11/16	1	1-3/16	2.76	4-11/16	5-1/2	1.10	3-7/16	5-1/2	2-5/8	7-1/4
4	16mm	3/4	4-1/2	1/2	5/8	7/16	1-11/16	1	1-3/16	3.32	5-7/16	6-1/4	1.10	3-7/16	5-1/2	2-5/8	7-1/4



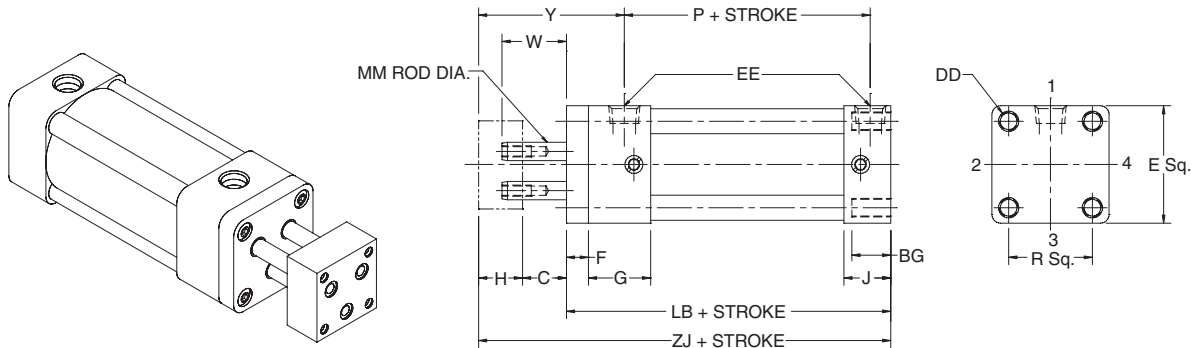
For inventory, lead times, and kit lookup, visit [www.pdnplu.com](http://www.pdnplu.com)

B98

**Parker Hannifin Corporation**  
Pneumatic Division  
Richland, Michigan  
[www.parker.com/pneumatics](http://www.parker.com/pneumatics)

Dimensional Data

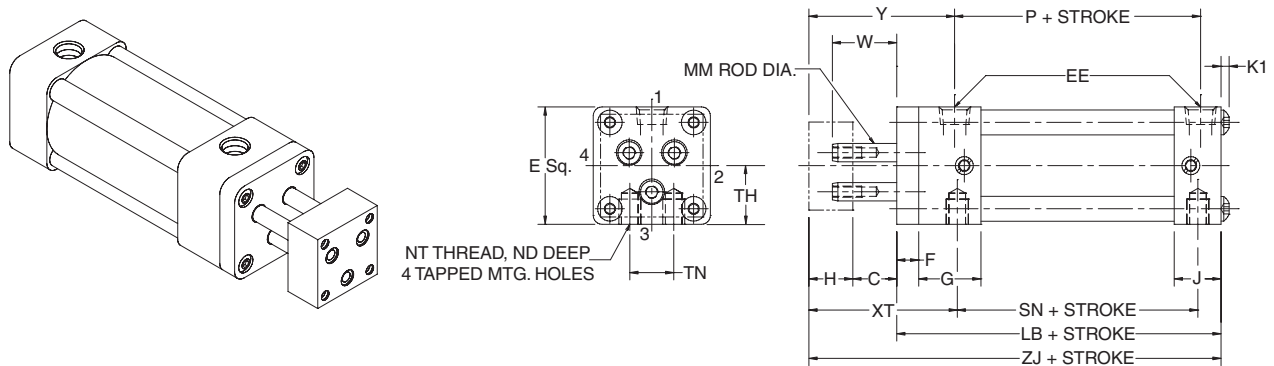
Sleeve Nut (Cap End Only) – Style TE (NFPA MX5)



Style TE and Dimensions

Bore	Rod dia. mm	BG	C	DD	E	EE (NPTF)	F	G	H	J	R	W	Y	Add stroke			
														LB	P	ZF	ZJ
1-1/2	8mm	0.45	3/4	1/4-28	2	1/4	3/8	1-7/16	3/4	15/16	1.43	1.10	2-3/4	4	2-5/16	5.10	5-1/2
2	12mm	0.48	3/4	5/16-24	2-1/2	1/4	3/8	1-7/16	3/4	15/16	1.84	1.10	2-3/4	4	2-5/16	5.10	5-1/2
2-1/2	16mm	0.48	3/4	5/16-24	3	3/8	3/8	1-7/16	1	15/16	2.19	1.35	3-1/16	4-1/8	2-3/8	5.35	5-7/8
3-1/4	16mm	0.50	3/4	3/8-24	3-3/4	1/2	3/8	1-11/16	1	1-3/16	2.76	1.10	3-7/16	4-7/8	2-5/8	5.23	6-5/8
4	16mm	0.50	3/4	3/8-24	4-1/2	1/2	3/8	1-11/16	1	1-3/16	3.32	1.10	3-7/16	4-7/8	2-5/8	5.98	6-5/8

Side Tapped Mount – Style F (NFPA MS4)



Style TC and Dimensions

Bore	Rod dia. mm	C	E	EE (NPTF)	F	G	H	J	K1	ND	NT	TH ±0.003	TN	W	XT	Y	Add stroke			
																	LB	P	SN	ZJ
1-1/2	8mm	3/4	2	1/4	3/8	1-7/16	3/4	15-16	1/8	3/8	1/4-20	0.993	5/8	1.10	2-13/16	2-3/4	4	2-5/16	2-1/4	5-1/2
2	12mm	3/4	2-1/2	1/4	3/8	1-7/16	3/4	15-16	5/32	7/16	5/16-18	1.243	7/8	1.10	2-13/16	2-3/4	4	2-5/16	2-1/4	5-1/2
2-1/2	16mm	3/4	3	3/8	3/8	1-7/16	1	15-16	5/32	5/8	3/8-16	1.493	1-1/4	1.35	3-1/16	3-1/16	4-1/8	2-3/8	2-3/8	5-7/8
3-1/4	16mm	3/4	3-3/4	1/2	5/8	1-11/16	1	1-3/16	3/16	3/4	1/2-13	1.868	1-1/2	1.10	3-7/16	3-7/16	4-7/8	2-5/8	2-3/8	6-5/8
4	16mm	3/4	4-1/2	1/2	5/8	1-11/16	1	1-3/16	3/16	3/4	1/2-13	2.243	2-1/16	1.10	3-7/16	3-7/16	4-7/8	2-5/8	2-3/8	6-5/8

B

Tie Rod Pneumatic  
Cylinders

4MA  
Series

4MAJ  
Series

2MNR  
Series

ACVB  
Option

LPSO  
Option

P1D  
Series



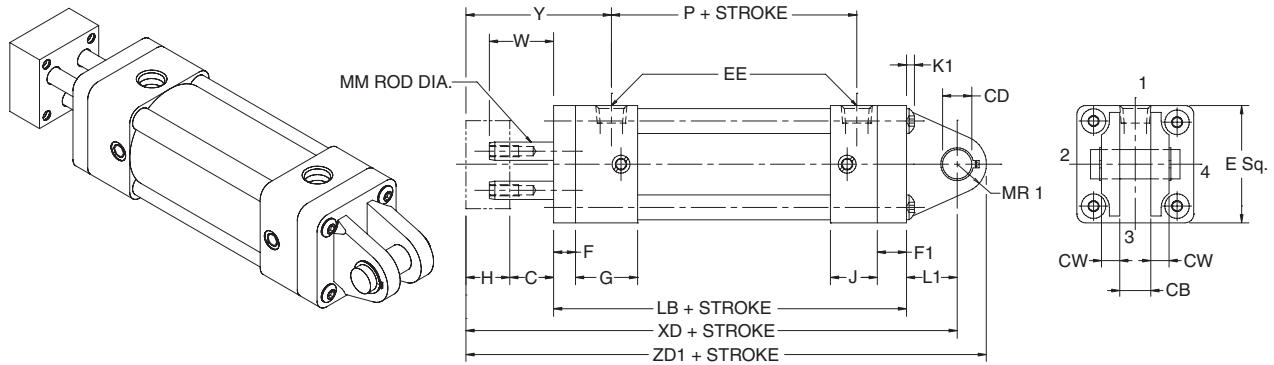
For inventory, lead time, and kit lookup, visit [www.pdnplu.com](http://www.pdnplu.com)

B99

Parker Hannifin Corporation  
Pneumatic Division  
Richland, Michigan  
[www.parker.com/pneumatics](http://www.parker.com/pneumatics)

Dimensional Data

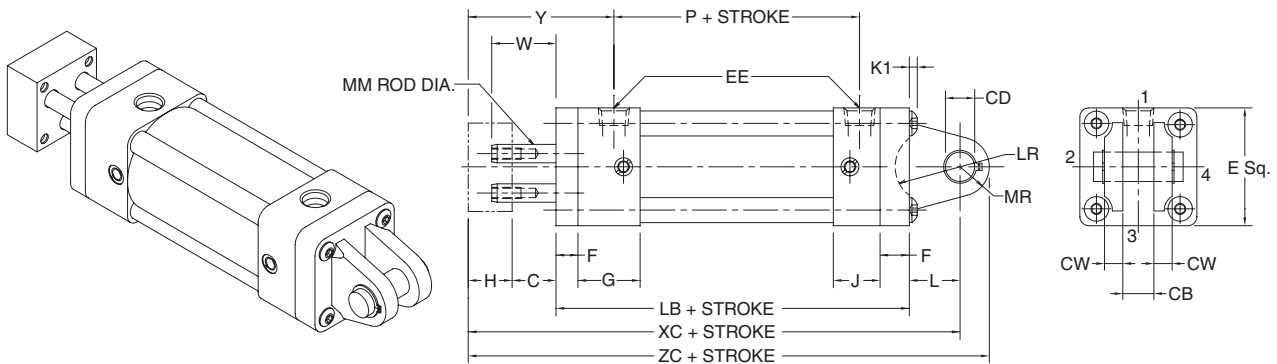
Cap Detachable Clevis – Style BC (NFPA MP2)



Style BC and Dimensions

Bore	Rod dia. mm	C	CB	CD +.000 -.002	CW	E	EE (NPTF)	F	F1	G	H	J	K1	L1	MR1	W	Y	Add stroke			
																		LB	P	XD	ZD1
1-1/2	8mm	3/4	3/4	0.501	1/2	2	1/4	3/8	3/8	1-7/16	3/4	15/16	1/8	3/4	1/2	1.10	2-3/4	4-3/8	2-5/16	6-5/8	7-1/8
2	12mm	3/4	3/4	0.501	1/2	2-1/2	1/4	3/8	3/8	1-7/16	3/4	15/16	5/32	3/4	1/2	1.10	2-3/4	4-3/8	2-5/16	6-5/8	7-1/8
2-1/2	16mm	3/4	3/4	0.501	1/2	3	3/8	3/8	3/8	1-7/16	1	15/16	5/32	3/4	1/2	1.35	3-1/16	4-1/2	2-3/8	7	7-1/2
3-1/4	16mm	3/4	1-1/4	0.751	5/8	3-3/4	1/2	3/8	5/8	1-11/16	1	1-3/16	3/16	1-1/4	3/4	1.10	3-7/16	5-1/2	2-5/8	8-1/2	9-1/4
4	16mm	3/4	1-1/4	0.751	5/8	4-1/2	1/2	3/8	5/8	1-11/16	1	1-3/16	3/16	1-1/4	3/4	1.10	3-7/16	5-1/2	2-5/8	8-1/2	9-1/4

Cap Fixed Clevis – Style BB (NFPA MP1)



Style BB and Dimensions

Bore	Rod dia. mm	C	CB	CD +.000 -.002	CW	E	EE (NPTF)	F	G	H	J	L	LR	MR	W	Y	Add stroke			
																	LB	P	XC	ZC
1-1/2	8mm	3/4	3/4	0.501	1/2	2	1/4	3/8	1-7/16	3/4	15-16	15/16	3/4	5/8	1.10	2-3/4	4-3/8	2-5/16	6-1/4	6-7/8
2	12mm	3/4	3/4	0.501	1/2	2-1/2	1/4	3/8	1-7/16	3/4	15-16	15/16	3/4	5/8	1.10	2-3/4	4-3/8	2-5/16	6-1/4	6-7/8
2-1/2	16mm	3/4	3/4	0.501	1/2	3	3/8	3/8	1-7/16	1	15-16	15/16	3/4	5/8	1.35	3-1/16	4-1/2	2-3/8	6-5/8	7-1/4
3-1/4	16mm	3/4	1-1/4	0.751	5/8	3-3/4	1/2	5/8	1-11/16	1	1-3/16	1-3/16	1	15/16	1.10	3-7/16	5-1/2	2-5/8	7-7/8	8-13/16
4	16mm	3/4	1-1/4	0.751	5/8	4-1/2	1/2	5/8	1-11/16	1	1-3/16	1-3/16	1	15/16	1.10	3-7/16	5-1/2	2-5/8	7-7/8	8-13/16



For inventory, lead times, and kit lookup, visit [www.pdnplu.com](http://www.pdnplu.com)

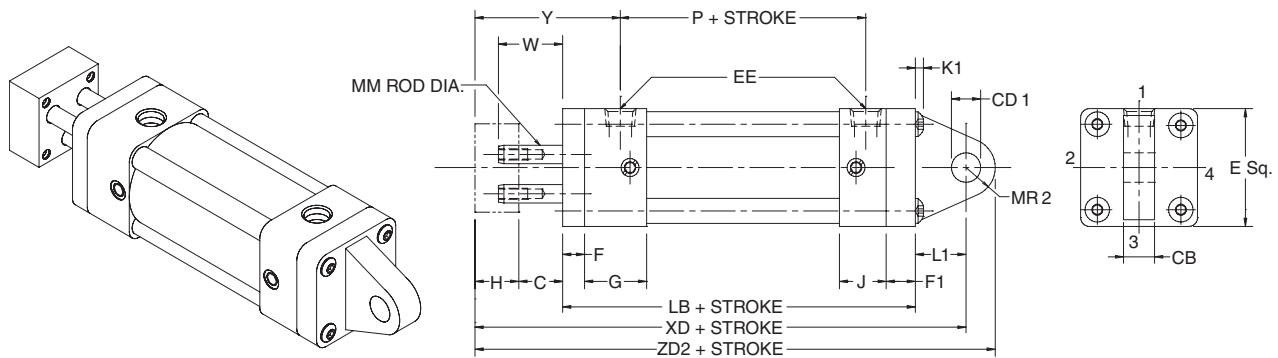
B100

**Parker Hannifin Corporation**  
Pneumatic Division  
Richland, Michigan  
[www.parker.com/pneumatics](http://www.parker.com/pneumatics)



Dimensional Data

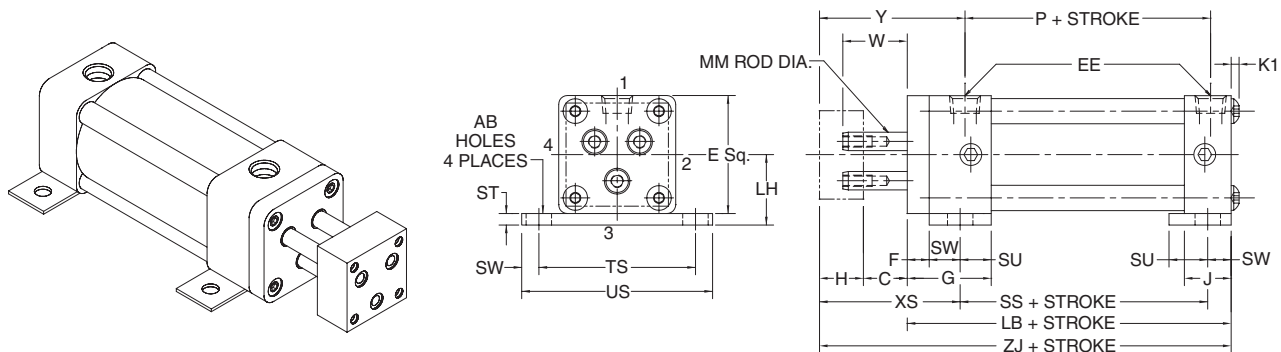
Detachable Pivot Eye – Style BE (NFPA MP4)



Style BE and Dimensions

Bore	Rod dia. mm	C	CB	CD +.000 -.002	E	EE (NPTF)	F	F1	G	H	J	K1	L1	MR2	W	Y	Add stroke			
																	LB	P	XD	ZD2
1-1/2	8mm	3/4	3/4	0.500	2	1/4	3/8	3/8	1-7/16	3/4	15/16	1/8	3/4	5/8	1.10	2-3/4	4-3/8	2-5/16	6-5/8	7-1/4
2	12mm	3/4	3/4	0.500	2-1/2	1/4	3/8	3/8	1-7/16	3/4	15/16	5/32	3/4	5/8	1.10	2-3/4	4-3/8	2-5/16	6-5/8	7-1/4
2-1/2	16mm	3/4	3/4	0.500	3	3/8	3/8	3/8	1-7/16	1	15/16	5/32	3/4	11/16	1.35	3-1/16	4-1/2	2-3/8	7	7-11/16
3-1/4	16mm	3/4	1-1/4	0.750	3-3/4	1/2	3/8	5/8	1-11/16	1	1-3/16	3/16	1-1/4	7/8	1.10	3-7/16	5-1/2	2-5/8	8-1/2	9-3/8
4	16mm	3/4	1-1/4	0.750	4-1/2	1/2	3/8	5/8	1-11/16	1	1-3/16	3/16	1-1/4	7/8	1.10	3-7/16	5-1/2	2-5/8	8-1/2	9-3/8

Base Bar – Style NB



Style NB and Dimensions

Bore	Rod dia. mm	AB	C	E	EE (NPTF)	F	G	H	J	K1	LH ±.000	ST	SU	SW	TS	US	W	XS	Y	Add stroke			
																				LB	P	SS	ZJ
1-1/2	8mm	7/16	3/4	2	1/4	3/8	1-1/2	3/4	15-16	1/8	15/16	1/4	1-1/8	3/8	2-3/4	3-1/2	1.10	2-1/4	2-3/4	4	2-5/16	2-7/8	5-1/2
2	12mm	7/16	3/4	2-1/2	1/4	3/8	1-1/2	3/4	15-16	5/32	15/16	1/4	1-1/8	3/8	3-1/4	4	1.10	2-1/4	2-3/4	4	2-5/16	2-7/8	5-1/2
2-1/2	16mm	7/16	3/4	3	3/8	3/8	1-1/2	1	15-16	5/32	15/16	3/8	1-1/8	3/8	3-3/4	4-1/2	1.35	2-1/2	3-1/16	4-1/8	2-3/8	3	5-7/8
3-1/4	16mm	9/16	3/4	3-3/4	1/2	5/8	1-3/4	1	1-3/16	3/16	1-3/16	1/2	1-1/4	1/2	4-3/4	5-3/4	1.10	2-7/8	3-7/16	4-7/8	2-5/8	3-1/4	6-5/8
4	16mm	9/16	3/4	4-1/2	1/2	5/8	1-3/4	1	1-3/16	3/16	1-3/16	1/2	1-1/4	1/2	5-1/2	6-1/2	1.10	2-7/8	3-7/16	4-7/8	2-5/8	3-1/4	6-5/8

B

Tie Rod Pneumatic  
Cylinders

4MA  
Series

4MAJ  
Series

2MNR  
Series

ACVB  
Option

LPSO  
Option

P1D  
Series



For inventory, lead time, and kit  
lookup, visit [www.pdnplu.com](http://www.pdnplu.com)

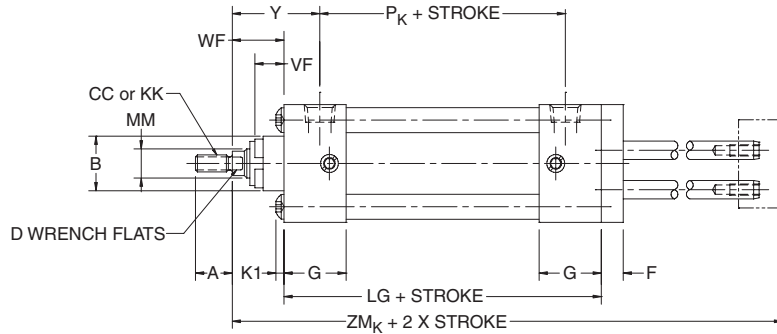
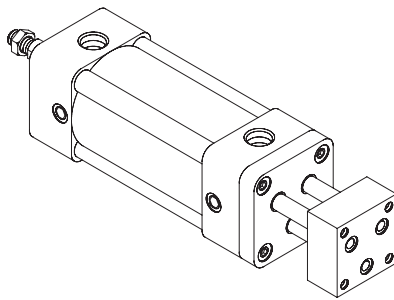
B101

Parker Hannifin Corporation  
Pneumatic Division  
Richland, Michigan  
[www.parker.com/pneumatics](http://www.parker.com/pneumatics)

**Dimensional Data**

**Double End – Style K**

Three rods with tooling plate one end  
 Single rod on the opposite end

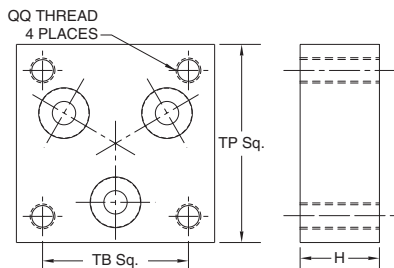


**Style K and Dimensions**

Bore	Rod no.	Rod dia. mm	Thread style		A	B + .000 - .002	C	D	F	G	H	K1	VF	WF	Y
			8 CC	4 & 9 KK											
1-1/2	1	5/8	1/2-20	7/16-20	3/4	1.124	3/4	1/2	3/8	1-7/16	3/4	1/8	5/8	1	1-7/8
2	1	5/8	1/2-20	7/16-20	3/4	1.124	3/4	1/2	3/8	1-7/16	3/4	5/32	5/8	1	1-7/8
2-1/2	1	5/8	1/2-20	7/16-20	3/4	1.124	3/4	1/2	3/8	1-7/16	1	5/32	5/8	1	1-15/16
3-1/4	1	1	7/8-14	3/4-16	1-1/8	1.499	3/4	7/8	5/8	1-11/16	1	3/16	3/4	1-3/8	2-7/16
4	1	1	7/8-14	3/4-16	1-1/8	1.499	3/4	7/8	5/8	1-11/16	1	3/16	3/4	1-3/8	2-7/16

Bore	Add stroke				Add 2X stroke	
	LG	SSK	SNK	PK	ZMK	ZMR
1-1/2	4-1/8	3-3/8	2-1/4	2-3/8	7	7-7/8
2	4-1/8	3-3/8	2-1/4	2-3/8	7	7-7/8
2-1/2	4-1/4	3-1/2	2-3/8	2-3/8	7-3/8	8-1/2
3-1/4	4-3/4	3-3/4	2-5/8	2-5/8	8-1/2	9-1/2
4	4-3/4	3-3/4	2-5/8	2-5/8	8-1/2	9-1/2
Option	Replaces dimension	SS	SN			
	On mtg. style	NB	F			

**Standard Tooling Plate – Style T**



Bore	H	QQ	TB	TP
1-1/2	3/4	10-32	1.12	1-1/2
2	3/4	1/4-28	1.43	2
2-1/2	1	5/16-24	1.84	2-1/2
3-1/4	1	3/8-24	2.19	3-1/4
4	1	3/8-24	2.76	4



For inventory, lead times, and kit lookup, visit [www.pdnplu.com](http://www.pdnplu.com)

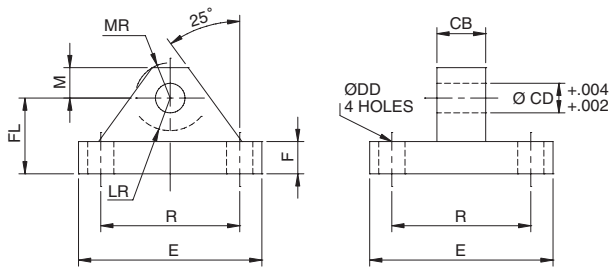
B102

**Parker Hannifin Corporation**  
 Pneumatic Division  
 Richland, Michigan  
[www.parker.com/pneumatics](http://www.parker.com/pneumatics)

**Accessories and Service Kits**

**Tie Rod Pneumatic Cylinders  
2MNR Series**

**Mounting Plate & Eye Bracket**



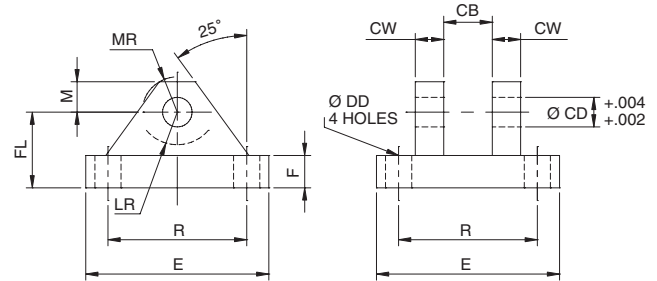
**Mounting Plate & Eye Bracket Dimensions**

Bore size	1-1/2, 2, 2-1/2	3-1/4, 4
Part number	1458060050	1458060075
CB	3/4	1-1/4
CD	1/2	3/4
DD	13/32	17/32
E	2-1/2	3-1/2
F	3/8	5/8
FL	1-1/8	1-7/8
LR	3/4	1-1/4
M	1/2	3/4
MR	9/16	7/8
R	1.63	2.55

**Seal Kits**

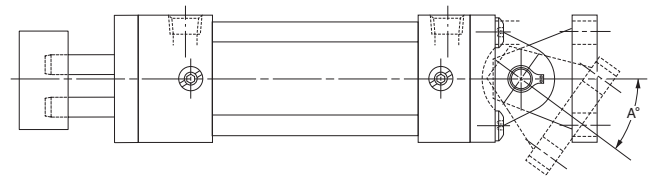
Bore size	Part number	
	Standard seal kit	Fluorocarbon seal kit
1-1/2	SG2MNR1501	SG2MNR1505
2	SG2MNR2001	SG2MNR2005
2-1/2	SG2MNR2501	SG2MNR2505
3-1/4	SG2MNR3201	SG2MNR3205
4	SG2MNR4001	SG2MNR4005

**Clevis Bracket**



**Clevis Bracket Dimensions**

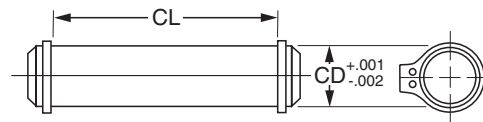
Bore size	1-1/2, 2, 2-1/2	3-1/4, 4
Part number	1458050050	1458050075
CB	3/4	1-1/4
CD	1/2	3/4
CW	1/2	5/8
DD	13/32	17/32
E	3-1/2	5
F	1/2	5/8
FL	1-1/2	1-7/8
LR	3/4	1-3/16
M	1/2	3/4
MR	5/8	2/32
R	2.55	3.82



Bore size	1-1/2	2	2-1/2	3-1/4	4
Angle A *	52	43	29	50	49

\* Angle of rotation specified is for BB style mount only.

**Pivot Pin**



**Pivot Pin Dimensions**

Part number	0856640050	0856640075
CD	1/2	3/4
CL	1-7/8	2-5/8

**B**

Tie Rod Pneumatic Cylinders

4MA Series

4MAJ Series

2MNR Series

ACVB Option

LPSO Option

P1D Series



For inventory, lead time, and kit lookup, visit [www.pdnplu.com](http://www.pdnplu.com)

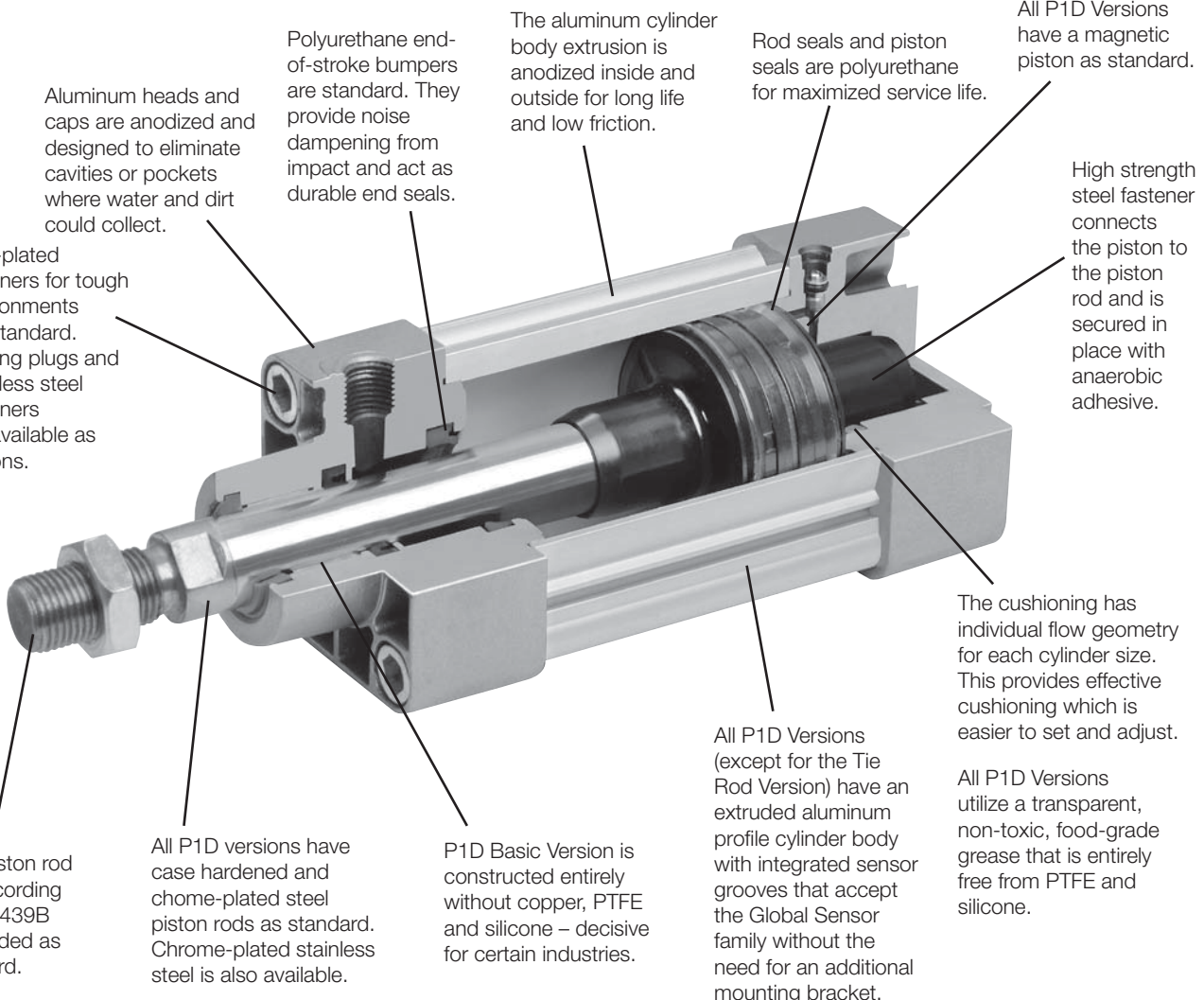
B103

**Parker Hannifin Corporation**  
Pneumatic Division  
Richland, Michigan  
[www.parker.com/pneumatics](http://www.parker.com/pneumatics)

**P1D Series – ISO Pneumatic Cylinders**

**Basic Version**

B	Tie Rod Pneumatic Cylinders
	Series
4MA Series	4MAJ Series
2MNR Series	ACVB Option
LPSO Option	P1D Series



**P1D Basic Version**

P1D Basic Version cylinders are available in 32-125mm bores and utilize internal composite technology to save weight, while assuring the high performance and functionality expected of ISO cylinders. Cushions and bumpers at both ends and a magnetic piston are included as standard. The Standard Version serves all markets where performance at an affordable price is desired.

**International standards**

The new P1D Series complies with the current ISO 6431, ISO/DIS 15552, VDMA 24562 and AFNOR installation dimensional standards for customer reassurance world-wide.

**Mechanically protected sensor technology**

The body extrusion has recessed sensor grooves on three sides of the cylinder. The new Global Sensors drop into the sensor groove quickly and easily. Both the cable and the sensor are protected. Choose a sensor in a variety of cable lengths and with flying leads, 8mm connector or 12mm connector.



**Optimized cushioning**

Thanks to the plastic inserts in the end covers, each cylinder bore has been given individual flow geometry. This provides optimized cushioning, which is quicker and easier to set and adjust.

**Smooth, quiet operation and long service life**

All seals and end-of-stroke bumpers are made from polyurethane (PUR), the bearings and piston are made from proven engineering plastics with excellent bearing properties and all cylinders are greased at the factory with a transparent, food-grade grease. Altogether, this gives the P1D Series very long service life and smooth, quiet operation.



For inventory, lead times, and kit lookup, visit [www.pdnplu.com](http://www.pdnplu.com)

**Options**

**Tie Rod Pneumatic Cylinders  
P1D Series**



**P1D Removable Gland Version**

P1D Removable Gland Version cylinders are available in 32-200mm bores and utilize bar stock endcaps and a removable high-strength bronze bearing for traditional and custom applications. The bronze bearing assembly is externally removable for quick and easy maintenance. No other ISO cylinder manufacturer in the world produces a Removable Gland Version and meets these demands. This version covers all applications which require performance and customization at all bore sizes.

**Removable Gland**

An extra-long inboard bearing surface ensures lubrication from within the cylinder. Outboard of the bearing are two leak-proof seals. The rod wiper seal wipes away any dirt on the rod. This means less wear on bearing surfaces and internal parts. The result is positive, no-leak sealing, regardless of conditions. And with the famous Parker removable style gland, you can replace the rod seals and/or bearings when necessary without disassembling the rest of the cylinder and without the need of any special wrenches.

**Aluminum Piston Option**

For high temperature applications, an aluminum piston is available with fluorocarbon seals. The piston is threaded onto the piston rod and secured in place with anaerobic adhesive which is temperature sensitive. For applications above 121°C (250°F) specify a pinned piston to rod connection. The polyurethane seals that are standard on the nylon piston are also an available option with the aluminum piston. The magnet that is cleverly hidden underneath the wear-band is also a standard feature on the aluminum piston. The durable wear-band prevents any metal-to-metal contact between the piston and the cylinder body wall increasing the overall life of the cylinder.

**Machined End Caps with Captive Cushion Screw Adjustment**

The end caps are made of precision lightweight aluminum. This allows for maximum flexibility and quick manufacturing for any customization that is required. The end caps also feature a captive cushion needle valve adjustment screw for optimized cushioning that is inherent throughout the P1D family of ISO cylinders.

**P1D Series Rod Lock Cylinder**

The P1D Series Rod Lock Cylinder incorporates a powerful piston rod locking device, which clamps the piston rod and locks it in position. The locking device is a spring lock with an air pressure release and is integrated into the front (head) cover of the cylinder.

In the absence of air signal pressure, full holding force is applied to the piston rod. When air is present at 4 bar (58 psi), the locking device is released.

The P1D Series Rod Lock Cylinder is available for cylinder bores 32-125mm. The design provides several valuable characteristics, such as:

- A holding force corresponding to a pressure of 7 bar (102 psi)
- A clean design, with the front (head) end cover and locking device built into a common block for compact installation
- Easy to clean, well-sealed construction
- Exhaust air from the locking device can be piped away when there are high demands for a contaminant free environment



**P1D Series Rod Lock Cylinder with Manual Override**

The P1D Series Rod Lock Cylinder with Manual Override is available for rod lock release during non-production activities. It incorporates the same features as the standard rod lock cylinder.



**B**

Tie Rod Pneumatic Cylinders

4MA Series

4MAJ Series

2MNR Series

ACVB Option

LPSO Option

P1D Series



For inventory, lead time, and kit lookup, visit [www.pdnplu.com](http://www.pdnplu.com)

B105

**Parker Hannifin Corporation**  
Pneumatic Division  
Richland, Michigan  
[www.parker.com/pneumatics](http://www.parker.com/pneumatics)

**P1D Clean Version**

The P1D Clean Version is completely designed for the food industry. The stringent requirements for hygiene regarding choice of material and corrosion resistance have guided the development of this cylinder version. Available with BSPP ports (ISO 1179-1 with ISO 228-1 threads).

All the main dimensions of the P1D Clean comply with ISO 6431, ISO/DIS 1555, VDMA 24562 and AFNOR standards except the somewhat larger footprint of the end covers and envelope of the body extrusion, due to the hygienic, convex, easy-to-clean geometry of the cushioning adjustment screw and the components of the integrated sensor system.

**Convex shape for optimum hygiene**

What makes the P1D Clean version unique is its convex body extrusion, which allows the cylinder to be kept clean. Regardless of orientation, fluids will run off the cylinder body surfaces.

**Sealing plugs**

Plastic sealing plugs are installed in the end cover screws which are not used for the cylinder installation. To ensure the sealing function, the plugs cannot be re-used. When installed in the end cover screws, they are tapped lightly with a hammer for high axial force.



**Cushioning screw with positive geometry**

To offer the best hygiene properties, the projecting cushioning screw is sealed against the end cover. This eliminates dirt-collecting cavities and gives the best hygiene, since it is so easy to clean.

**P1D Tie-Rod Version**

The P1D Tie-Rod Version cylinders are based on the same high level technology as the Basic Version. They accept either Standard Version or Removable Gland Version heads and caps. This cylinder is the perfect choice wherever a true tie-rod cylinder is needed.

**International standards**

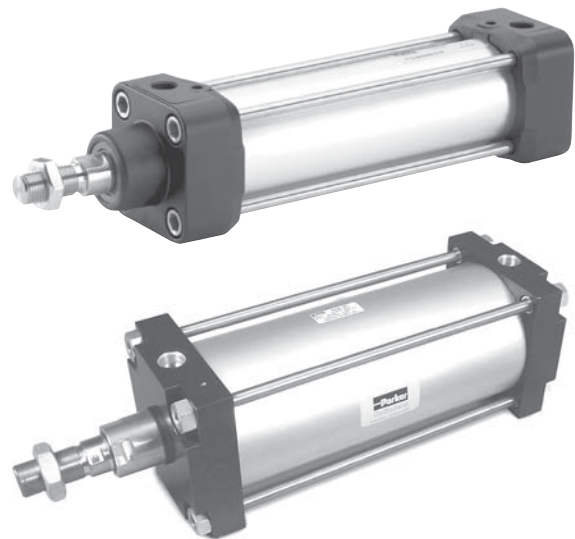
The P1D Tie-Rod Version complies with ISO 6431, ISO/DIS 15552, VDMA 24562 and AFNOR installation dimension standards, for customer reassurance world-wide.

**“Drop-in” sensor**

The P1D Tie-Rod Version utilizes the same drop-in Global Sensors as the other versions. An ingenious multi-jointed adapter clamps the sensors to the tie rod in any chosen position along the stroke.

**Large Bore Sizes**

The P1D Tie-Rod Version is now available in 160 and 200mm bore sizes.



**32-125mm bores**

P Tie Rod Pneumatic Cylinders	4MA Series
	4MAJ Series
2MNR Series	
ACVB Option	
LPSO Option	
P1D Series	



For inventory, lead times, and kit lookup, visit [www.pdnplu.com](http://www.pdnplu.com)

**Options**

**Design Versions**

**P1D Basic Version**

The P1D Basic Version cylinders meet the specifications in the ISO 15552 standard. This means full interchangeability to any ISO 15552 cylinder anywhere around the globe. P1D Basic Version will be available throughout the extensive worldwide Parker Hannifin organization.



**P1D Standard Version**

P1D Standard Version cylinders are available in 32-125mm bores and utilize internal composite technology to save weight, while assuring the high performance and functionality expected of ISO cylinders. Cushions and bumpers at both ends and a magnetic piston are included as standard. The Standard Version serves all markets where performance at an affordable price is desired.



**P1D Removable Gland Version**

P1D Removable Gland Version cylinders are available in 32-200mm bores and utilize bar stock endcaps and a removable high-strength bronze bearing for traditional and custom applications. The bronze bearing assembly is externally removable for quick and easy maintenance. No other ISO cylinder manufacturer in the world produces a Removable Gland Version and meets these demands. This version covers all applications which require performance and customization at all bore sizes.



**P1D Rod Lock Cylinder**

The P1D Rod Lock Cylinder incorporates a powerful piston rod locking device, which clamps the piston rod and locks it in position. The locking device is a spring lock with an air pressure release and is integrated into the front (head) cover of the cylinder.



**P1D Clean Version**

The P1D Clean Version is completely designed for the food industry. The stringent requirements for hygiene regarding choice of material and corrosion resistance have guided the development of this cylinder version. Available with BSPP ports (ISO 1179-1 with ISO 228-1 threads).



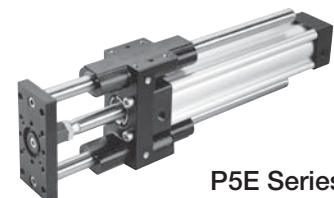
**P1D Tie-Rod Version**

The P1D Tie-Rod Version cylinders are based on the same high level technology as the Standard Version. They accept either Standard Version or Removable Gland Version heads and caps. This cylinder is the perfect choice wherever a true tie-rod cylinder is needed.



**Guided Cylinders**

For guided versions of the P1D, see the P5E Series and HB Series.



**P5E Series**

**B**

Tie Rod Pneumatic Cylinders

4MA Series

4MAJ Series

2MNR Series

ACVB Option

LPSO Option

P1D Series



For inventory, lead time, and kit lookup, visit [www.pdnplu.com](http://www.pdnplu.com)

B107

**Parker Hannifin Corporation**  
Pneumatic Division  
Richland, Michigan  
[www.parker.com/pneumatics](http://www.parker.com/pneumatics)

## Common Part Numbers

## Tie Rod Pneumatic Cylinders P1D Series

The innovative P1D is a long lasting ISO/VDMA cylinder. The cylinders are double acting, with a new design of air cushioning.

The P1D complies with the current ISO 6431, ISO 15552, VDMA 24562 and AFNOR installation dimension standards

- Available in 32 to 200mm bores
- PUR seals for long service life
- Drop-in sensors
- Corrosion resistant design
- Magnetic piston as standard
- Lubricated with food grade grease



### Operating information

Operating pressure:	145 PSIG (10 bar) maximum
Temperature range:	Standard: -4°F to 176°F (-20°C to 80°C) High temperature: 14°F to 250°F (-10°C to 121°C)
Cylinders for low pressure hydraulic operation:	Ø32 - 125mm
ATEX approval:	CE Ex IIGD c T4 248°F (120°C)
Filtration requirements:	40 micron, dry filtered air

### P1D Standard - Double acting

#### Ø32mm - (G<sup>1/8</sup>)

Stroke (mm)	Order Code
25	P1D-S032MC-0025NNNNN
40	P1D-S032MC-0040NNNNN
50	P1D-S032MC-0050NNNNN
80	P1D-S032MC-0080NNNNN
100	P1D-S032MC-0100NNNNN
125	P1D-S032MC-0125NNNNN
160	P1D-S032MC-0160NNNNN
200	P1D-S032MC-0200NNNNN
250	P1D-S032MC-0250NNNNN
320	P1D-S032MC-0320NNNNN
400	P1D-S032MC-0400NNNNN
500	P1D-S032MC-0500NNNNN

#### Ø63mm - (G<sup>3/8</sup>)

Stroke (mm)	Order Code
25	P1D-S063MC-0025NNNNN
40	P1D-S063MC-0040NNNNN
50	P1D-S063MC-0050NNNNN
80	P1D-S063MC-0080NNNNN
100	P1D-S063MC-0100NNNNN
125	P1D-S063MC-0125NNNNN
160	P1D-S063MC-0160NNNNN
200	P1D-S063MC-0200NNNNN
250	P1D-S063MC-0250NNNNN
320	P1D-S063MC-0320NNNNN
400	P1D-S063MC-0400NNNNN
500	P1D-S063MC-0500NNNNN

#### Ø100mm - (G<sup>1/2</sup>)

Stroke (mm)	Order Code
25	P1D-S100MC-0025NNNNN
40	P1D-S100MC-0040NNNNN
50	P1D-S100MC-0050NNNNN
80	P1D-S100MC-0080NNNNN
100	P1D-S100MC-0100NNNNN
125	P1D-S100MC-0125NNNNN
160	P1D-S100MC-0160NNNNN
200	P1D-S100MC-0200NNNNN
250	P1D-S100MC-0250NNNNN
320	P1D-S100MC-0320NNNNN
400	P1D-S100MC-0400NNNNN
500	P1D-S100MC-0500NNNNN

#### Ø40mm - (G<sup>1/4</sup>)

Stroke (mm)	Order Code
25	P1D-S040MC-0025NNNNN
40	P1D-S040MC-0040NNNNN
50	P1D-S040MC-0050NNNNN
80	P1D-S040MC-0080NNNNN
100	P1D-S040MC-0100NNNNN
125	P1D-S040MC-0125NNNNN
160	P1D-S040MC-0160NNNNN
200	P1D-S040MC-0200NNNNN
250	P1D-S040MC-0250NNNNN
320	P1D-S040MC-0320NNNNN
400	P1D-S040MC-0400NNNNN
500	P1D-S040MC-0500NNNNN

#### Ø80mm - (G<sup>3/8</sup>)

Stroke (mm)	Order Code
25	P1D-S080MC-0025NNNNN
40	P1D-S080MC-0040NNNNN
50	P1D-S080MC-0050NNNNN
80	P1D-S080MC-0080NNNNN
100	P1D-S080MC-0100NNNNN
125	P1D-S080MC-0125NNNNN
160	P1D-S080MC-0160NNNNN
200	P1D-S080MC-0200NNNNN
250	P1D-S080MC-0250NNNNN
320	P1D-S080MC-0320NNNNN
400	P1D-S080MC-0400NNNNN
500	P1D-S080MC-0500NNNNN

#### Ø125mm - (G<sup>1/2</sup>)

Stroke (mm)	Order Code
25	P1D-S125MC-0025NNNNN
40	P1D-S125MC-0040NNNNN
50	P1D-S125MC-0050NNNNN
80	P1D-S125MC-0080NNNNN
100	P1D-S125MC-0100NNNNN
125	P1D-S125MC-0125NNNNN
160	P1D-S125MC-0160NNNNN
200	P1D-S125MC-0200NNNNN
250	P1D-S125MC-0250NNNNN
320	P1D-S125MC-0320NNNNN
400	P1D-S125MC-0400NNNNN
500	P1D-S125MC-0500NNNNN

#### Ø50mm - (G<sup>1/4</sup>)

Stroke (mm)	Order Code
25	P1D-S050MC-0025NNNNN
40	P1D-S050MC-0040NNNNN
50	P1D-S050MC-0050NNNNN
80	P1D-S050MC-0080NNNNN
100	P1D-S050MC-0100NNNNN
125	P1D-S050MC-0125NNNNN
160	P1D-S050MC-0160NNNNN
200	P1D-S050MC-0200NNNNN
250	P1D-S050MC-0250NNNNN
320	P1D-S050MC-0320NNNNN
400	P1D-S050MC-0400NNNNN
500	P1D-S050MC-0500NNNNN

The cylinders are supplied complete with a zinc plated steel piston rod nut.

Most popular.

### Sensors

See section L for sensors.



For inventory, lead times, and kit lookup, visit [www.pdnplu.com](http://www.pdnplu.com)

B108



**Ordering information**

P1D
-
S
032
M
C
-
0500
N
N
N
N
N

Piston Style		
Cushions	Piston material	
	Composite <sup>1</sup>	Aluminum <sup>2</sup>
None	M	Y
Cush B/E	- <sup>3, 20</sup>	4
Cush head	J	5
Cush cap	K	6

Bore size	
032	32mm
040	40mm
050	50mm
063	63mm
080	80mm
100	100mm
125	125mm
160	160mm <sup>8</sup>
200	200mm <sup>8</sup>

Stroke <sup>14</sup>	
Specify whole mm using 4 digits, i.e. 0500	

Rod end	
N	Metric male
6	Metric female
3	Special*

\* Please provide desired dimensions for KK, AM and WH or W. If otherwise, please provide dimensioned sketch.

Version				
	Cylinder body profile	Rod lock		
		None	Fitted w/ standard rod lock <sup>7</sup>	Fitted w/ manual override rod lock <sup>7</sup>
Die cast end caps <sup>4</sup>	Basic	B	N/A	N/A
	Standard	S	L	N/A
	Tie Rod <sup>13</sup>	T	M	N/A
	Clean	C	D	N/A
Machined end caps rod lock not available with removable gland. <sup>5</sup>	Standard	G <sup>5</sup>	R	J
	Tie Rod <sup>13</sup>	E <sup>5</sup>	7 <sup>4</sup>	Consult Factory
Special <sup>6</sup>	Any Special	/		

Function				
Fastener type	Rod wiper style	Double acting	Double rod	Tandem <sup>13</sup>
Standard end cover screws	Std scraper	M <sup>20</sup>	F	C
	Metal scraper	Q	R	J
Stainless steel end cover screws <sup>9</sup>	Std scraper	A	G	N/A
	Metal scraper	S	T	N/A

Piston rod & seal material			
Piston rod material	Seal material		
	Standard	Fluorocarbon <sup>10</sup>	Hydraulic <sup>11</sup>
Chrome plated carbon steel <sup>2</sup>	C <sup>20</sup>	G	J
Chrome plated stainless steel <sup>2, 19</sup>	R <sup>20</sup>	D	Z
303 Stainless steel <sup>13</sup>	S	N/A	N/A
Acid-resistant stainless steel	M	N <sup>2</sup>	N/A

Cylinder ports front & rear		
-	BSPP Ports (G Threads)**	
E	NPTF Ports*	
Q	BSPT Ports (R, Threads)*†	

\* Not available on clean version.  
† Not available on die cast version.  
\*\* ISO 1179-1 with ISO 228-1 threads.

Rod mountings & plugs <sup>15</sup>		
Rod mounting	No plugs <sup>16, 20</sup>	With plugs <sup>1</sup>
Swivel rod eye	S	A
Swivel rod eye SS	T	1
Swivel rod eye with clevis bracket GA <sup>19</sup>	V	E
Swivel rod eye SS with clevis bracket GA	W	2
Clevis	C	B
Clevis SS	D	3
Flexco coupling	F	G
One additional piston rod nut	X	P
Stainless steel piston rod nut	Y	4
Acid-resistant nut	Z	5
None (piston rod nut only)	N	R

Sensors <sup>17</sup>			
Prepared for factory-fitted sensors	Cable location		
	Front or left	Rear or right	Front & rear
P1D clean version	6	7	8
P1D all versions (except Clean) prepared for sensors or clean version without sensor capability <sup>18, 20</sup>	N		

Mounting style		
	Standard <sup>20</sup>	Rotated 90°
Flange MF1 at head (front) end	1	3
Flange MF2 at cap (rear) end	B	4
Flanges MF1 and MF2 at both ends	2	K
Foot brackets MS1	F	R
Clevis bracket GA aluminum	C	U
Rear eye MP4 aluminum	E	V
Rear swivel eye MP6 aluminum	S	W
Clevis bracket MP2 aluminum	T	Y
Rear eye + clevis (MP4 + MP2) aluminum	L	Z
Clevis bracket MP2 + pivot hinge aluminum	X	5
Clevis bracket GA aluminum + steel swivel hinge	Q	0
Rear swivel eye + clevis bracket GA aluminum	M	A
Intermediate trunnion MT4 (requires XV dimension)	G	7
Trunnion flange at head (front) end <sup>4</sup>	H	P
Trunnion flange at cap (rear) end <sup>4</sup>	J	8
None (MX0)	N	9

**Notes:**

- Not available for 160-200mm bores.
- Not available on Clean Version.
- Must be placed in model code.
- Not available for 160-200mm bores or with fluorocarbon seals.
- When Removable Gland Version is fitted with rod lock, gland cannot be replaced without disassembling cylinder.
- If special cylinder is ordered (other than rod end), End Cap Style, Cylinder Body Profile and Rod Lock option must be given in addition to the special request.
- Cylinders fitted with rod locks must be cushioned on both ends.
- Tie Rod Version E must be specified for these bores.
- Applies only to end cover screws for 32-125mm bores. For stainless steel tie rods and nuts (all bore sizes), change Version to special and request stainless steel tie rods and nuts.
- If used for temperature above 80°C (176°F), aluminum piston required. Not available with die cast end caps.
- Hydraulic seal option valid for Removable Gland Version only. Adjustable cushion options and Rod Lock Versions not available.
- Only available on Clean Version.
- Tie Rod Version is required for Tandem Function.
- When specifying a stop tube, place a "/" in the version field. Then specify the version, amount of stop tube and amount of net stroke. The stroke used in the model code should be gross stroke (net stroke plus stop tube).
- Please review Piston Rod Selection Chart in the Engineering Section to check for a rod buckling condition.
- Clean Version comes standard with plugs. Use this column when ordering Clean Version.
- For sensor part numbers and specifications, please refer to Electronic Sensors section.
- P1D Clean Version ordered without sensors cannot be retrofitted with sensor capability.
- Consult factory for this option.
- Only option for Basic Version.

**Double Rod Cylinders**  
Double rod option is available with Mounting Styles MX0, MS1, MF1, MF2 and MT4.  
For double rod cylinders, it is assumed that the rod number and rod end are the same for both piston rods. On a double rod cylinder where the two rod ends are different, use a rod end of '3' and be sure to clearly state which rod end is to be assembled at which end.

**B**  
Tie Rod Pneumatic Cylinders  
4MA Series  
4MAJ Series  
2MNR Series  
ACVB Option  
LPSO Option  
P1D Series

**For ordering purposes, when special options or common modifications are requested, the factory will assign a sequential part number in place of the model number.**



For inventory, lead time, and kit lookup, visit [www.pdnplu.com](http://www.pdnplu.com)

B109

**Parker Hannifin Corporation**  
Pneumatic Division  
Richland, Michigan  
[www.parker.com/pneumatics](http://www.parker.com/pneumatics)

# Specifications

# Tie Rod Pneumatic Cylinders P1D Series

## General Specifications

- Bore sizes 32-200mm
- Max stroke 2800mm
- Min stroke 25mm  
(must specify Tie Rod Version for strokes <25mm)
- Rod Ends – 2 standard, specials to order
- Single rod end and double rod end styles
- Working pressure Max 10 bar (145 PSI)
- Working temperature –  
-20°C to 80°C (-4°F to 176°F) standard  
-10°C to 121°C (14°F to 250°F) high temp version
- Aluminum piston is required for service above 80°C (176°F)
- Greased for life (non-lube), does not normally need additional lubrication. If air line lubrication is initiated, it must always be continued.
- Working medium: Dry, filtered compressed air to ISO 8573-1 class 3. 4. 3. or better

## P1D Rod Lock Version

- Fluid Medium: Dry, filtered, compressed air
  - Maximum Cylinder Operating Pressure: 10 bar (145 PSI)
  - Required Pressure to Unlock<sup>1</sup>: 4 bar (58 PSI)
  - Minimum Torque Required for Manual Override Version:
    - 32mm Bore = 0.9 N-m / 8 in-lbs
    - 40mm Bore = 0.9 N-m / 8 in-lbs
    - 50mm Bore = 2.7 N-m / 24 in-lbs
    - 63mm Bore = 2.7 N-m / 24 in-lbs
    - 80mm Bore = 27.1 N-m / 240 in-lbs
    - 100mm Bore = 36.6 N-m / 324 in-lbs
    - 125mm Bore = 61.0 N-m / 540 in-lbs
  - Maximum Operating Temperature: -10°C to 75°C (14°F to 167°F)  
Min stroke 10mm
  - Maximum Cylinder Operating Speed: 5 feet per second
- <sup>1</sup> Signal pressure to port on locking device. Operation at pressures lower than 4 bar (58 psi) may lead to inadvertent engagement of the rod lock device.

## Quick Reference

Bore size	Cylinder area, cm <sup>2</sup>	Piston rod			Cushioning length mm	Air consumption <sup>1</sup> liter	Connection thread <sup>4</sup>	Theoretical cylinder forces at 6 bar (N) <sup>2</sup>	
		Dia. mm	Area, cm <sup>2</sup>	Male thread				Extend stroke	Retract stroke
32	8.0	12	1.1	M10x1.25	17	0.105	G1/8	482	414
40	12.6	16	2.0	M12x1.25	19	0.162	G1/4	754	633
50	19.6	20	3.1	M16x1.5	20	0.253	G1/4	1178	989
63	31.2	20	3.1	M16x1.5	23	0.414	G3/8	1870	1681
80	50.3	25	4.9	M20x1.5	23	0.669	G3/8	3016	2721
100	78.5	25	4.9	M20x1.5	27	1.043	G1/2	4712	4417
125	122.7	32	8.0	M27x2	30	1.662	G1/2	7363	6880
160	201.1	40	12.6	M36x2	38	2.724	G3/4	12,064	11,310
200	314.2	40	12.6	M36x2	38	4.256	G3/4	18,850	18,096

Cylinder bore size	Total mass (kg)				Total mass (kg) moving components	
	0mm stroke <sup>3</sup>		Supplement per 10mm stroke		at 0mm stroke	Supplement per 10mm stroke
	Basic	Tie-Rod	Basic	Tie-Rod		
32	0.55	0.54	0.023	0.022	0.13	0.009
40	0.80	0.79	0.033	0.030	0.24	0.016
50	1.20	1.20	0.048	0.048	0.42	0.025
63	1.73	1.73	0.051	0.051	0.50	0.025
80	2.45	2.47	0.075	0.079	0.90	0.039
100	4.00	4.00	0.084	0.084	1.10	0.039
125	6.87	6.73	0.138	0.129	2.34	0.063
160	—	16.19	—	0.160	Consult Factory	Consult Factory
200	—	22.23	—	0.185	Consult Factory	Consult Factory

<sup>1</sup> Free air consumption per 10mm stroke for a double stroke at 6 bar

<sup>2</sup> The values for cylinder forces are theoretical and should be reduced to suit working conditions.

<sup>3</sup> Total Mass for composite piston for 32-125mm bores and aluminum piston for 160-200mm bores.

<sup>4</sup> ISO 1179-1 with ISO 228-1 threads



For inventory, lead times, and kit lookup, visit [www.pdnplu.com](http://www.pdnplu.com)

B110

**Parker Hannifin Corporation**  
Pneumatic Division  
Richland, Michigan  
[www.parker.com/pneumatics](http://www.parker.com/pneumatics)

## Material Specifications

### Basic & Standard Version

Body extrusion	Clear anodized aluminium
End covers	Anodized aluminum
End cover inserts	POM
End cover nuts/screws	Zinc plated steel 8.8
Piston rod nut	Zinc plated steel
Piston rod	Chrome-plated steel (standard)
Rod wiperseal	PUR
Piston rod bearing	POM
Piston	POM
Piston bearing	POM
Magnetic ring	Plastic bound magnetic material
Piston fastener	Zinc plated steel (composite piston)
Piston seal	PUR
O-rings	Nitrile rubber, NBR
End-of-stroke bumpers and end seals	PUR
Cushioning seals	PUR
Cushioning screws	PA

### Piston Rod Material Options

(or with equivalent properties):

Standard	Case-hardened, chrome plated carbon steel
Chrome plated stainless steel	17-4 PH, chrome plated stainless steel
Stainless steel	303 stainless steel
Acid-resistant stainless steel	316 stainless steel



## Tie Rod Pneumatic Cylinders

### P1D Series

### Additional/Substitute Specifications

#### P1D Tie-Rod Version

Tie-rods	Blackened steel
----------	-----------------

#### P1D Removable Gland Version

End covers	Black anodized aluminum
End cover screws	Zinc plated steel 8.8 (32-125mm bores)
Cylinder Body	Clear anodized aluminum
Rod gland	PTFE filled high strength bronze
Rod seal	Buna Nitrile for sealing action
Rod wiper	Buna Nitrile for wiping action
Piston rod	Case hardened chrome-plated steel
Piston rod nut	Zinc plated steel
Piston	POM (standard) Aluminum (optional)
Piston seals	PUR
Piston bearing	POM or Molyguard wear band for aluminum piston
Magnetic ring	Plastic bound magnetic material
Piston fastener	Zinc plated steel (composite piston)
O-rings	Buna Nitrile
Cushioning seals	PUR
Cushioning screws	Stainless steel (brass for 160 and 200mm bores)

#### Design Variants for Removable Gland Version

High temperature option includes:

All seals	Fluorocarbon
Piston	Aluminum (without magnetic ring)

Low pressure hydraulic option includes:

Rod seal	Buna Nitrile
Rod wiper	PUR
Piston seals	Buna Nitrile
Piston	Aluminum (non-cushioned)

Metallic Rod Scraper includes:

Rod wiper	Dual high strength bronze wipers with nitrile or fluorocarbon energizer
-----------	---

**B**

Tie Rod Pneumatic Cylinders

4MA Series

4MAJ Series

2MNR Series

ACVB Option

LPSO Option

P1D Series



For inventory, lead time, and kit lookup, visit [www.pdnplu.com](http://www.pdnplu.com)

B111

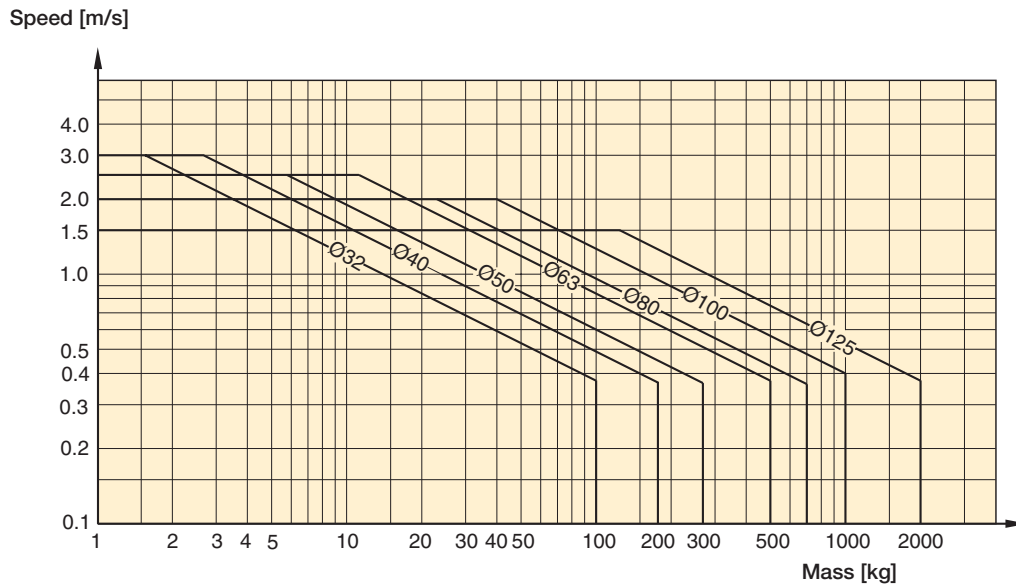
**Parker Hannifin Corporation**  
Pneumatic Division  
Richland, Michigan  
[www.parker.com/pneumatics](http://www.parker.com/pneumatics)

**Cushioning Characteristics**

The diagram below is used for sizing of cylinders related to the cushioning capacity. The maximum cushioning capacity shown in the diagram assumes the following:

- Low load, i.e. low pressure drop across the piston
- Equilibrium speed
- Correctly adjusted cushioning screw
- 6 bar at cylinder port

The load is the sum of internal and external friction, plus any gravitational forces. At high relative load (pressure drop exceeding 1 bar), we recommend that for any given speed, the mass should be reduced by a factor of 2.5, or for a given mass, the speed should be reduced by a factor of 1.5. This is in relation to the maximum performance given in the diagram.



**Recommended Air Quality for Cylinders**

For best possible service life and trouble-free operation, ISO 8573-1 quality class 3.4.3 should be used. This means 5 µm filter (standard filter) dew point 3°C (37°F) for indoor operation (a lower dew point should be selected for outdoor operation) and oil concentration 1.0 mg oil/m<sup>3</sup>, which is what a standard compressor with a standard filter gives.

**ISO 8573-1 Quality Classes**

Quality class	Pollution		Water		Oil
	Particle size (mm)	Max. concentration (mg/m <sup>3</sup> )	Max pressure dew point (°C) (°F)		Max. concentration (mg/m <sup>3</sup> )
1	0.1	0.1	-70	-94	0.01
2	1	1	-40	-40	-0.1
3	5	5	-20	-4	1.0
4	15	8	+3	+37	5.0
5	40	10	+7	+44	25
6	-	-	+10	+50	-

**B**  
 Tie Rod Pneumatic Cylinders  
 4MA Series  
 4MAJ Series  
 2MNR Series  
 ACVB Option  
 LPSO Option  
 P1D Series



For inventory, lead times, and kit lookup, visit [www.pdnplu.com](http://www.pdnplu.com)

B112

**Parker Hannifin Corporation**  
 Pneumatic Division  
 Richland, Michigan  
[www.parker.com/pneumatics](http://www.parker.com/pneumatics)

**Guide for Selecting Suitable Tubing**

The selection of the correct size of tubing is often based on experience, with no great thought to optimizing energy efficiency and cylinder velocity. This is usually acceptable, but making a rough calculation can result in worthwhile economic gains.

**The following is the basic principle:**

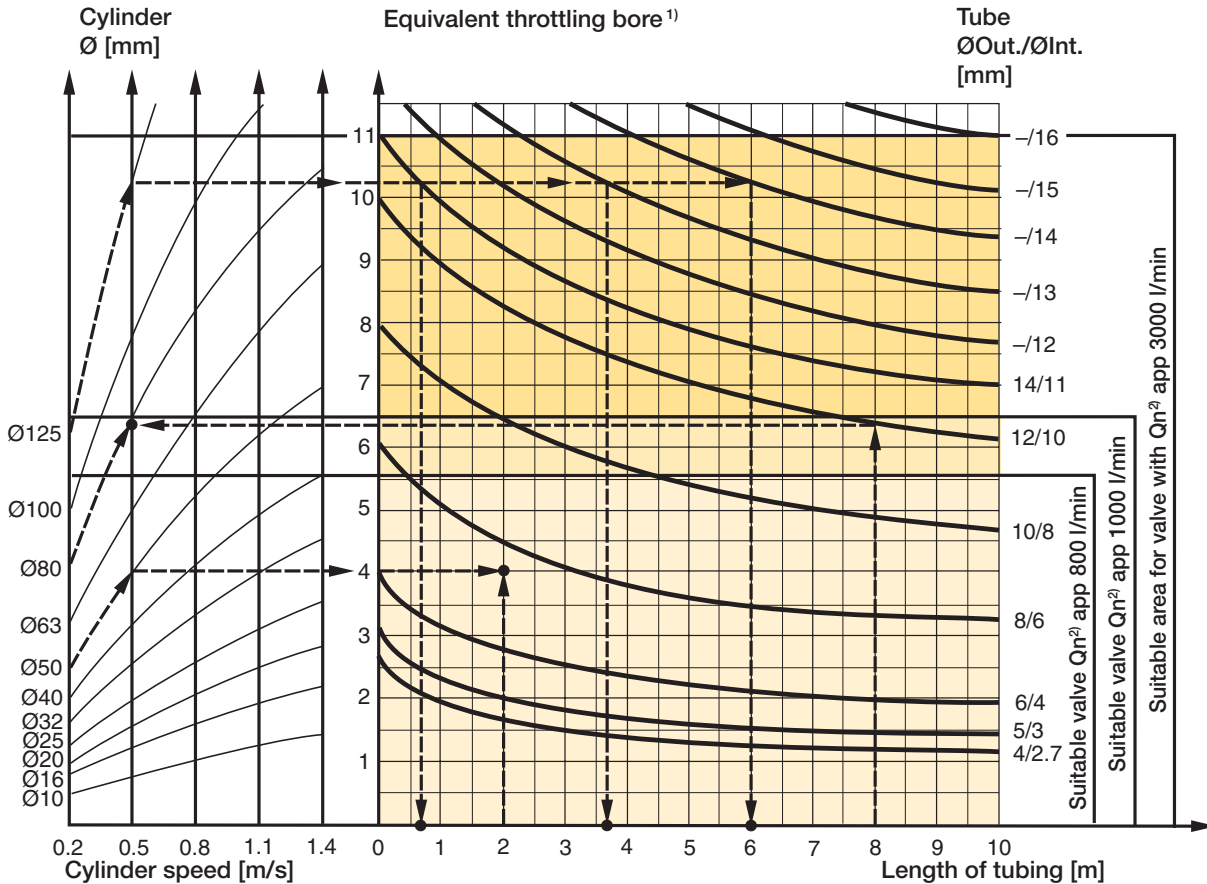
1. The primary line to the working valve could be oversized (this does not cause any extra air consumption and consequently does not create any extra costs in operation).
2. The tubes between the valve and the cylinder should, however, be optimized according to the principle that an insufficient bore throttles the flow and thus limits the cylinder speed, while an oversized pipe creates a dead volume which increases the air consumption and filling time.

The chart below is intended to help when selecting the correct size of tube to use between the valve and the cylinder.

**The following prerequisites apply:**

The cylinder load should be about 50% of the theoretical force (= normal load). A lower load gives a higher velocity and vice versa. The tube size is selected as a function of the cylinder bore, the desired cylinder velocity and the tube length between the valve and the cylinder.

If you want to use the capacity of the valve to its maximum, and obtain maximum speed, the tubing should be chosen so that they at least correspond with the equivalent restriction diameter (see description below), so that the tubing does not restrict the total flow. This means that a short tubing must have at least the equivalent restriction diameter. If the tubing is longer, choose it from the table below. Straight fittings should be chosen for highest flow rates. (Elbow and banjo fittings cause restriction.)



- 1) The "equivalent throttling bore" is a long throttle (for example a tube) or a series of throttles (for example, through a valve) converted to a short throttle which gives a corresponding flow rate. This should not be confused with the "orifice" which is sometimes specified for valves. The value for the orifice does not normally take account of the fact that the valve contains a number of throttles.
- 2) Qn is a measure of the valve flow capacity, with flow measured in liter per minute (l/min) at 6 bar(e) supply pressure and 1 bar pressure drop across the valve.

<b>B</b>
Tie Rod Pneumatic Cylinders
4MA Series
4MAJ Series
2MNR Series
ACVB Option
LPSO Option
P1D Series



For inventory, lead time, and kit lookup, visit [www.pdnplu.com](http://www.pdnplu.com)

B113

**Parker Hannifin Corporation**  
 Pneumatic Division  
 Richland, Michigan  
[www.parker.com/pneumatics](http://www.parker.com/pneumatics)

**P1D Rod Lock Version – Rod Lock Data**

**Connection**

The signal air for the locking device can be obtained directly from a main air supply, or from the air supply serving the valve that controls the cylinder itself. For controlled ON/OFF operation of the locking device, a separate quick-venting valve is used.

The piston rod should not be moving when the locking device is activated. The locking device is not intended to brake a movement in repeated sequences.

**Holding Forces\***

Bore size	Holding forces	
	(N)	(lbs)
32mm	550	123
40mm	860	193
50mm	1345	303
63mm	2140	481
80mm	3450	755
100mm	5390	1211
125mm	8425	1894

**NOTE:** All P1D Rod Lock Versions are not intended for use in water service applications, or in environments that have high humidity levels and/or splashing fluids present.

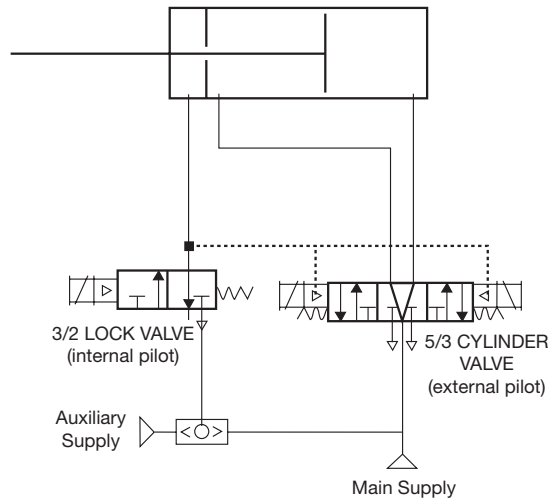
\* While cylinder is on extend at 87 PSI.

**Use as a Brake**

The chart to the right shows the maximum values for speed and braking mass if the cylinder is used as a brake. The cylinder should not be exposed to additional compressive forces as this significantly reduces the external mass that can be braked.

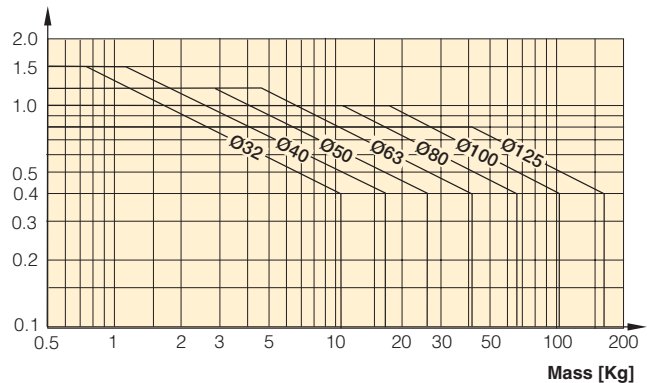
We recommend systems in which the cylinder does not act as a motor during braking. Heat is generated if the brake is used frequently, and this must be taken into account to ensure that the maximum temperature is not exceeded.

**Sample Pneumatic Circuit**

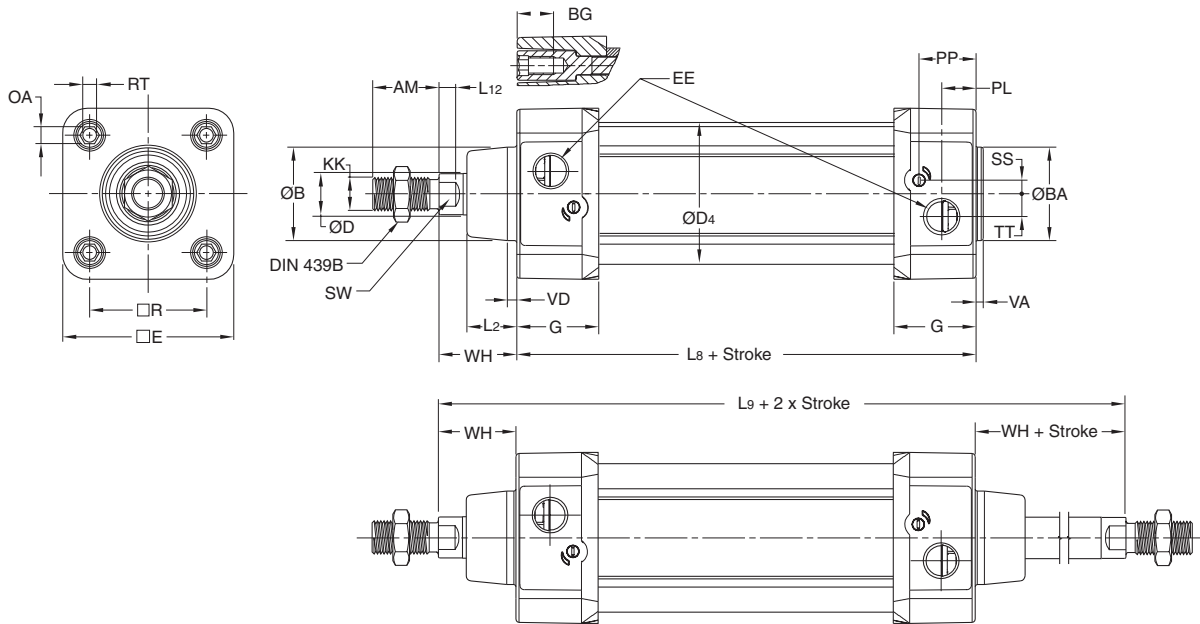


1. Lock valve must be maintained energized during cylinder motion, otherwise rod lock is engaged and cylinder valve shifts to mid position.
2. Cylinder valve must be maintained energized during extend or retract. Also keep energized at end of stroke until change of direction is desired.
3. Mid position of 5/3 Cylinder valve may be pressurized outlets if the combination of pressure load on the cylinder and inertia effects of the attached load do not exceed the holding force rating of the rod lock device, including allowance for wear.
4. Do not use cylinder lines for any logic functions — pressure levels vary too much.

**Speed [m/s]**



**P1D Basic & Standard Version**



**Basic & Standard Version**

Bore size	AM mm	B mm	BA mm	BG mm	D mm	D4 mm	E mm	EE		G mm	KK †	L2 mm	L8 mm	L9 mm	L12 mm
								BSPP *	NPTF/BSPT						
32	22	30	30	16	12	5.0	50.0	G1/8	1/8	28.5	M10x1.25	16.0	94	146	6.0
40	24	35	35	16	16	52.0	57.4	G1/4	1/4	33.0	M12x1.25	19.0	105	165	6.5
50	32	40	40	16	20	60.7	69.4	G1/4	1/4	33.5	M16x1.5	24.0	106	180	8.0
63	32	45	45	16	20	71.5	82.4	G3/8	3/8	39.5	M16x1.5	24.0	121	195	8.0
80	40	45	45	17	25	86.7	99.4	G3/8	3/8	39.5	M20x1.5	30.0	128	220	10.0
100	40	55	55	17	25	106.7	116.0	G1/2	1/2	44.5	M20x1.5	32.4	138	240	10.0
125	54	60	60	20	32	134.0	139.0	G1/2	1/2	51.0	M27x2	45.0	160	290	13.0

Bore size	OA mm	PL mm	PP mm	R mm	RT	SS mm	SW mm	TT mm	VA mm	VD mm	WH mm
40	6	14	21.9	38.0	M6	8.0	13	5.5	3.5	4.5	30
50	8	14	25.9	46.5	M8	4.0	17	7.5	3.5	4.5	37
63	8	16	27.4	56.5	M8	6.5	17	11.0	3.5	4.5	37
80	6	16	30.5	72.0	M10	0	22	15.0	3.5	4.5	46
100	6	18	35.8	89.0	M10	0	22	20.0	3.5	4.5	51
125	8	23	40.5	110.0	M12	0	27	17.5	3.5	6.5	65

\* ISO 1179-1 with IS20 228-1 threads.

**B**

Tie Rod Pneumatic Cylinders

4MA Series

4MAJ Series

2MNR Series

ACVB Option

LPSO Option

P1D Series



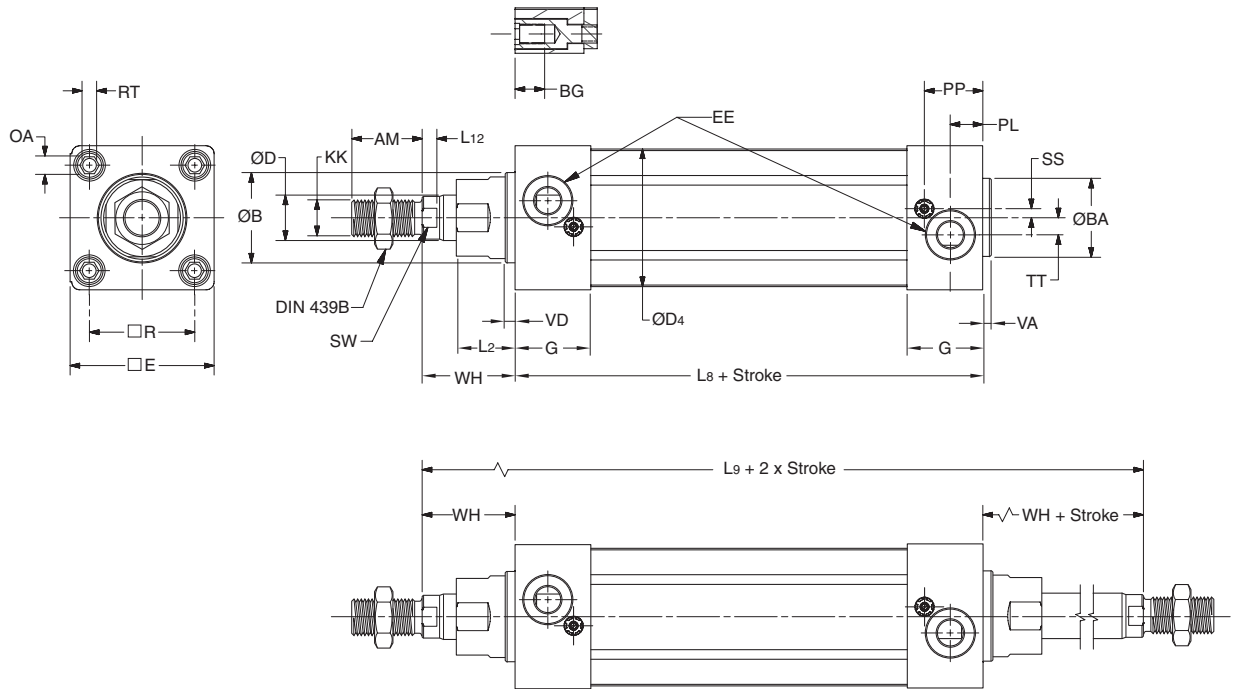
For inventory, lead time, and kit lookup, visit [www.pdnplu.com](http://www.pdnplu.com)

B115

**Parker Hannifin Corporation**  
Pneumatic Division  
Richland, Michigan  
[www.parker.com/pneumatics](http://www.parker.com/pneumatics)

Removable Gland Version

P1D Removable Gland Version



Removable Gland Version

Bore size	AM mm	B mm	BA mm	BG mm	D mm	D4 mm	E mm	EE		G mm	KK	L2 mm	L8 mm	L9 mm	L12 mm
								BSPP *	NPTF/BSPT						
32	22	30	30	16	12	45.0	46.5	G1/8	1/8	28.5	M10x1.25	18	94	146	6.0
40	24	35	35	16	16	52.0	52.0	G1/4	1/4	33.0	M12x1.25	20	105	165	6.5
50	32	40	40	16	20	60.7	63.5	G1/4	1/4	33.5	M16x1.5	26	106	180	6.5
63	32	45	45	16	20	71.5	76.0	G3/8	3/8	39.5	M16x1.5	26	121	195	6.5
80	40	45	45	17	25	86.7	95.5	G3/8	3/8	39.5	M20x1.5	33	128	220	10.0
100	40	55	55	17	25	106.7	114.5	G1/2	1/2	44.5	M20x1.5	33	138	240	10.0
125	54	60	60	20	32	134.0	140.0	G1/2	1/2	51.0	M27x2	41	160	290	13.0

Bore size	OA mm	PL mm	PP mm	R mm	RT	SS mm	SW mm	TT mm	VA mm	VD mm	WH mm
32	6	13	21.8	32.5	M6	6.5	10	4.5	3.5	4.5	26
40	6	14	21.9	38.0	M6	8.0	13	5.5	3.5	4.5	30
50	8	14	25.9	46.5	M8	4.0	17	7.5	3.5	4.5	37
63	8	16	27.4	56.5	M8	6.5	17	11.0	3.5	4.5	37
80	6	16	30.5	72.0	M10	0	22	15.0	3.5	4.5	46
100	6	18	35.8	89.0	M10	0	22	20.0	3.5	4.5	51
125	8	23	40.5	110.0	M12	0	27	17.5	5.5	6.5	65

\* ISO 1179-1 with ISO 228-1 threads



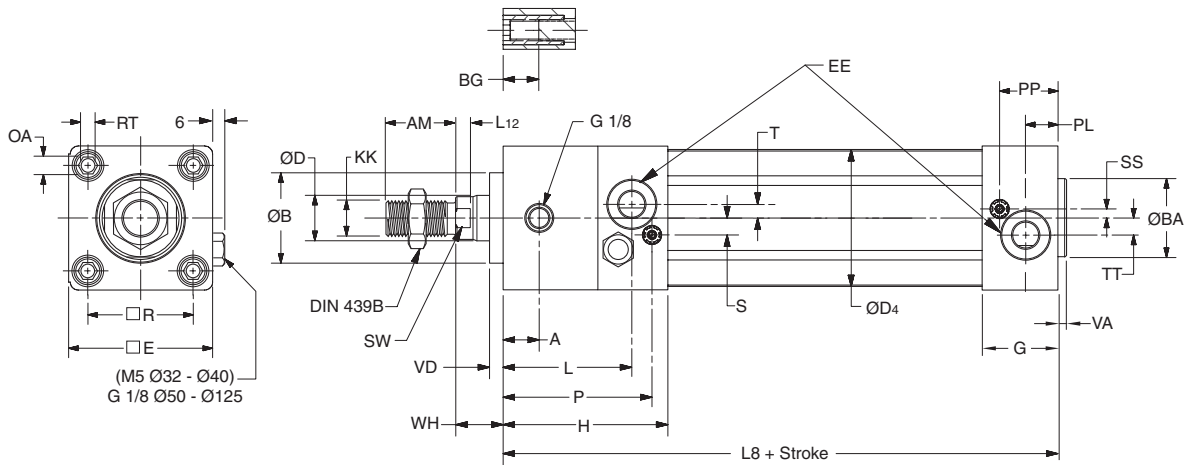
For inventory, lead times, and kit lookup, visit [www.pdnplu.com](http://www.pdnplu.com)

B116

Parker Hannifin Corporation  
Pneumatic Division  
Richland, Michigan  
[www.parker.com/pneumatics](http://www.parker.com/pneumatics)



**P1D Rod Lock (Version R or L)**



**Rod Lock (Version R or L)**

Bore size	A mm	AM mm	B mm	BA mm	BG mm	D mm	D4 mm	E mm	EE *	G mm	H mm	KK	L mm	L8 mm	L12 mm
32	16	22	30	30	16	12	45.0	46.5	G1/8	28.5	71.5	M10x1.25	56.0	137	6.0
40	16	24	35	35	16	16	52.0	52.0	G1/4	33.0	77.0	M12x1.25	56.0	149	6.5
50	18	32	40	40	16	20	60.7	63.5	G1/4	33.5	80.5	M16x1.5	62.5	153	6.5
63	26	32	45	45	16	20	71.5	76.0	G3/8	39.5	96.5	M16x1.5	74.5	178	6.5
80	35	40	45	45	17	25	86.7	95.5	G3/8	39.5	110.5	M20x1.5	87.0	209	10.0
100	50	40	55	55	17	25	106.7	114.5	G1/2	44.5	132.5	M20x1.5	106.0	236	10.0
125	60	54	60	60	20	32	134.0	140.0	G1/2	51.0	145.0	M27x2	117.0	264	13.0

Bore size	OA mm	P mm	PL mm	PP mm	R mm	RT mm	S mm	SS mm	SW mm	T mm	TT mm	VA mm	VD mm	WH mm
32	6	64.8	13	21.8	32.5	M6	7	6.5	10	2.5	4.5	3.5	4.5	15
40	6	68.0	14	21.9	38.0	M6	9	8.0	13	2.0	5.5	3.5	4.5	16
50	8	73.5	14	25.9	46.5	M8	8	4.0	17	4.0	7.5	3.5	5.0	17
63	8	89.5	16	27.4	56.5	M8	8	6.5	17	2.0	11.0	3.5	5.0	17
80	6	101.5	16	30.5	72.0	M10	9	0	22	5.0	15.0	3.5	4.0	20
100	6	123.5	18	35.8	89.0	M10	12	0	22	6.0	20.0	3.5	4.0	20
125	8	136.0	23	40.5	110.0	M12	12	0	27	6.0	17.5	5.5	6.0	27

\* ISO 1179-1 with ISO 228-1 threads

**B**

Tie Rod Pneumatic Cylinders

4MA Series

4MAJ Series

2MNR Series

ACVB Option

LPSO Option

P1D Series



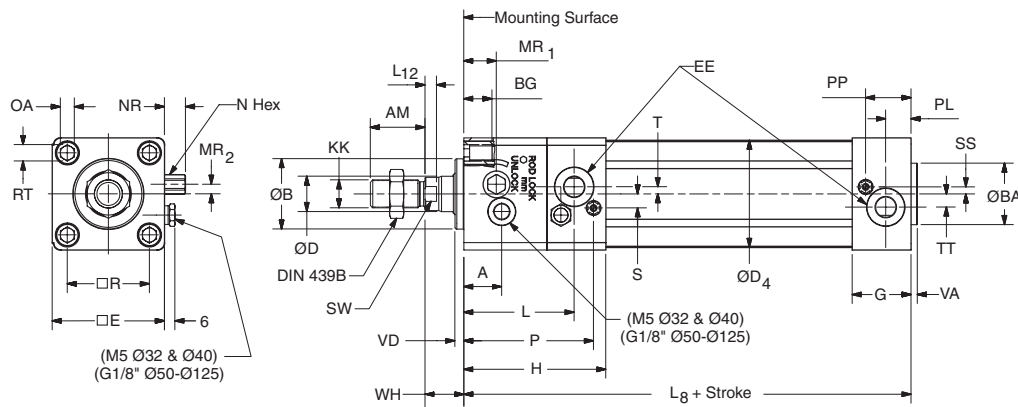
For inventory, lead time, and kit lookup, visit [www.pdnplu.com](http://www.pdnplu.com)

B117

**Parker Hannifin Corporation**  
Pneumatic Division  
Richland, Michigan  
[www.parker.com/pneumatics](http://www.parker.com/pneumatics)

Rod Lock Version J

P1D Rod Lock Version with Manual Override (Version J)



4MA Series  
Rod Lock Version with Manual Override (Version J)

Bore size	A mm	AM mm	B mm	BA mm	BG mm	D mm	D4 mm	E mm	EE <sup>1</sup>	G mm	H mm	KK	L mm	L8 mm	L12 mm	MR1 mm	MR2 mm
32	27.0	22	30	30	16	12	45.0	46.5	G1/8	28.5	71.5	M10X1.25	56.0	137	6.0	16.0	3.0
40	27.0	24	35	35	16	16	52.0	52.0	G1/4	33.0	77.0	M12X1.25	56.0	149	6.5	16.0	3.0
50	21.5	32	40	40	16	20	60.7	63.5	G1/4	33.5	80.5	M16X1.5	62.5	153	6.5	18.5	5.5
63	39.0	32	45	45	16	20	71.5	76.0	G3/8	39.5	96.5	M16X1.5	74.5	178	6.5	22.0	4.0
80	38.5	40	45	45	17	25	86.7	95.5	G3/8	39.5	110.5	M20X1.5	87.0	209	10.0	15.0	19.8
100	55.0	40	55	55	17	25	106.7	114.5	G1/2	44.5	132.5	M20X1.5	106.0	236	10.0	15.0	20.8
125	61.0	54	60	60	20	32	134.0	140.0	G1/2	51.0	145.0	M27X2	117.0	264	13.0	19.0	23.0

Bore size	N mm	NR mm	OA mm	P mm	PL mm	PP mm	R mm	RT	S mm	SS mm	SW mm	T mm	TT mm	VA mm	VD mm	WH mm
32	8	10.0	6	64.8	13	21.8	32.5	M6	7	6.5	10	2.5	4.5	3.5	4.5	15
40	8	10.0	6	68.0	14	21.9	38.0	M6	9	8.0	13	2.0	5.5	3.5	4.5	16
50	10	12.0	8	73.5	14	25.9	46.5	M8	8	4.0	17	4.0	7.5	3.5	5.0	17
63	10	12.0	8	89.5	16	27.4	56.5	M8	8	6.5	17	2.0	11.0	3.5	5.0	17
80	11	12.5	6	101.5	16	30.5	72.0	M10	9	0	22	5.0	15.0	3.5	14.0	30
100	11	12.5	6	123.5	18	35.8	89.0	M10	12	0	22	6.0	20.0	3.5	14.0	30
125	11	12.5	8	136.0	23	40.5	110.0	M12	12	0	27	6.0	17.5	5.5	16.0	37

<sup>1</sup> ISO 1179-1 with ISO 228-1 threads

Tolerances

Bore size	B mm	R mm	L8 mm	BA mm	Stroke-length tolerance mm
32	d11	±0.5	±0.4	d11	+1/-0
40	d11	±0.5	±0.7	d11	+1/-0
50	d11	±0.6	±0.7	d11	+1/-0
63	d11	±0.7	±0.8	d11	+1/-0
80	d11	±0.7	±0.8	d11	+1/-0
100	d11	±0.7	±1.0	d11	+1/-0
125	d11	±1.1	±1.0	d11	+1/-0

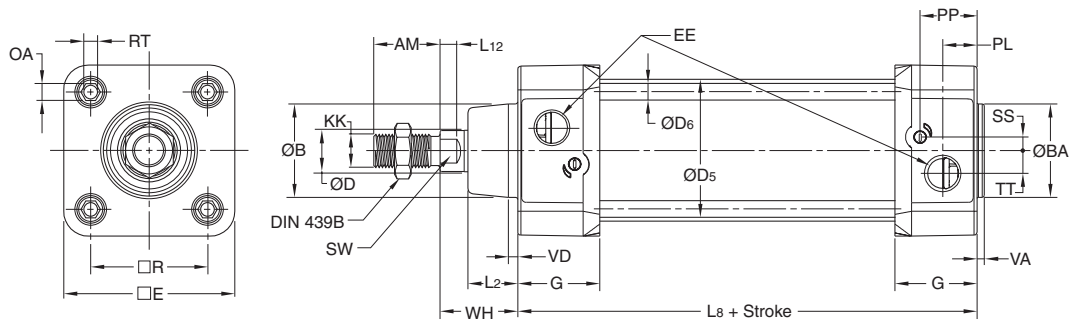


For inventory, lead times, and kit lookup, visit [www.pdnplu.com](http://www.pdnplu.com)

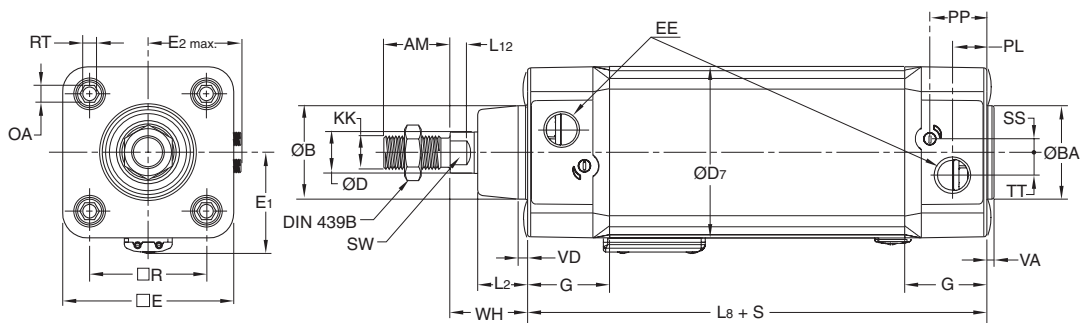
B118

Parker Hannifin Corporation  
Pneumatic Division  
Richland, Michigan  
[www.parker.com/pneumatics](http://www.parker.com/pneumatics)

**P1D Tie-Rod Version (32-125mm)**



**P1D Clean Version**



**Tie-Rod & Clean Version (32-125mm)**

Bore size	AM mm	B mm	BA mm	D mm	D5 mm	D6 mm	D7 mm	E	E1 mm	E2 max mm	EE		G mm	KK †
											BSPP *	NPTF/BSPT		
32	22	30	30	12	36	5.3	49.6	50.0	32	5	G1/8	1/8	28.5	M10x1.25
40	24	35	35	16	45	5.3	57.3	57.4	36	6	G1/4	1/4	33.0	M12x1.25
50	32	40	40	20	55	7.1	69.3	69.4	42	6	G1/4	1/4	33.5	M16x1.5
63	32	45	45	20	68	7.1	82.3	82.4	49	5	G3/8	3/8	39.5	M16x1.5
80	40	45	45	25	85	8.9	99.3	99.4	57	5	G3/8	3/8	39.5	M20x1.5
100	40	55	55	25	105	8.9	117.6	116.0	68	6	G1/2	1/2	44.5	M20x1.5
125	54	60	60	32	132	10.7	142.8	139.0	81	6	G1/2	1/2	51.0	M27x2

Bore size	L2 mm	L8 mm	L12 mm	OA mm	PL mm	PP mm	R mm	RT	SS mm	SW mm	TT mm	VA mm	VD mm	WH mm
32	16.0	94	6.0	6	13	21.8	32.5	M6	4.0	10	4.5	3.5	4.5	26
40	19.0	105	6.5	6	14	21.9	38.0	M6	8.0	13	5.5	3.5	4.5	30
50	24.0	106	8.0	8	14	25.9	46.5	M8	4.0	17	7.5	3.5	4.5	37
63	24.0	121	8.0	8	16	27.4	56.5	M8	6.5	17	11.0	3.5	4.5	37
80	30.0	128	10.0	6	16	30.5	72.0	M10	0	22	15.0	3.5	4.5	46
100	32.4	138	10.0	6	18	35.8	89.0	M10	0	22	20.0	3.5	4.5	51
125	45.0	160	13.0	8	23	40.5	110.0	M12	0	27	17.5	3.5	6.5	65

\* ISO 1179-1 with IS20 228-1 threads.

**B**

Tie Rod Pneumatic Cylinders

4MA Series

4MAJ Series

2MNR Series

ACVB Option

LPSO Option

P1D Series



For inventory, lead time, and kit lookup, visit [www.pdnplu.com](http://www.pdnplu.com)

B119

**Parker Hannifin Corporation**  
 Pneumatic Division  
 Richland, Michigan  
[www.parker.com/pneumatics](http://www.parker.com/pneumatics)

**P1D Tie-Rod Version (160-200mm)**

**B**  
Tie Rod Pneumatic  
Cylinders

4MA  
Series

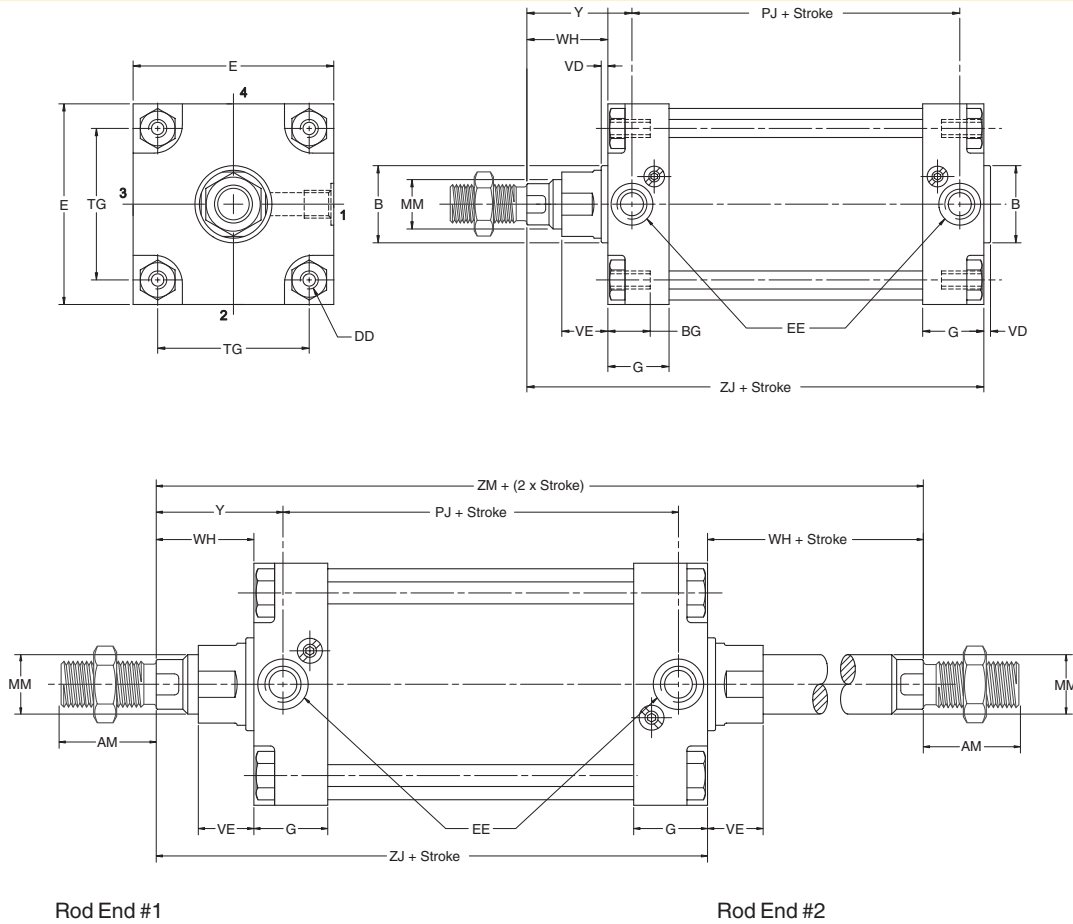
4MAJ  
Series

2MNR  
Series

ACVB  
Option

LPSO  
Option

P1D  
Series



**P1D Tie-Rod Version (160-200mm)**

Bore size	AM mm	B d11 mm	BG mm	DD	E mm	EE		G mm	MM mm	TG mm	VD mm	VE mm	WH mm	Y mm	PJ1 mm	ZJ1 mm	ZM2 mm
						BSPP <sup>3</sup>	NPTF/BSPT										
160	72	65	24	M16	177	G3/4	3/4	54	40	140	6	56	80	105	130	260	340
200	72	75	24	M16	214	G3/4	3/4	54	40	175	6	56	95	120	130	275	370

<sup>1</sup> Add stroke  
<sup>2</sup> Add 2x stroke  
<sup>3</sup> ISO 1179-1 with ISO 228-1 threads

**Double Rod Cylinders**

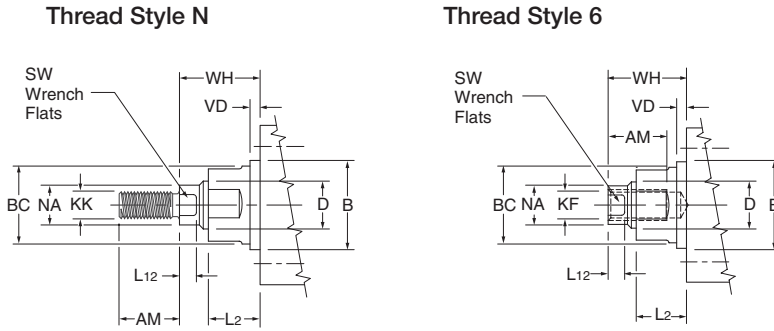
Double rod option is available on Mounting Styles MX0, MS1, MF1, MF2 and MT4.

For double rod cylinders, it is assumed that the rod number and rod end are the same for both piston rods. On a double rod cylinder where the two rod ends are different, use a rod end of '3' and be sure to clearly state which rod end is to be assembled at which end.



For inventory, lead times, and kit lookup, visit [www.pdnplu.com](http://www.pdnplu.com)

All Mountings Except MF1



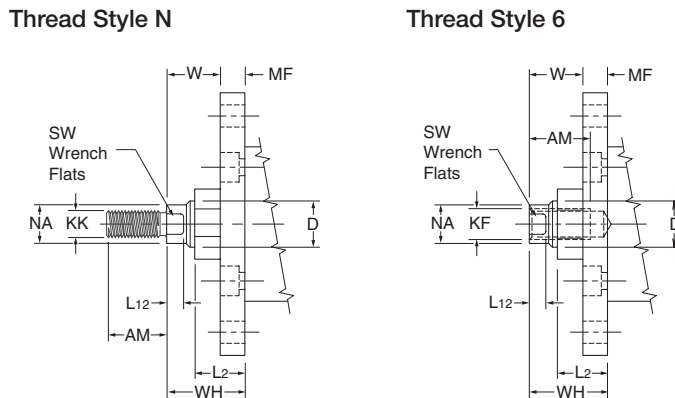
Thread Style 3 - "Special Thread"

Special thread, extension, rod eye, blank, etc are also available. To order, specify "Style 3" and provide desired dimensions for KF or KK, AM and WH. If otherwise special, furnish dimensioned sketch.

Bore size	D	KK	KF	AM	B d11	BC	SW across flats	L12	NA	VD	L2	WH*
32	12	M10x1.25	M8x1	22	30	27	10	6	11	4.5	18	26
40	16	M12x1.25	M10x1.25	24	35	32	13	6.5	15	4.5	20	30
50	20	M16x1.5	M14x1.5	32	40	36	17	6.5	19	4.5	26	37
63	20	M16x1.5	M14x1.5	32	45	36	17	6.5	19	4.5	26	37
80	25	M20x1.5	M18x1.5	40	45	41	22	10	24	4.5	33	46
100	25	M20x1.5	M18x1.5	40	55	41	22	10	24	4.5	33	51
125	32	M27x2	M24x2	54	60	50	27	13	31	6.5	41	65
160	40	M36x2	M30x2	72	65	60	36	16	39	6	56	80
200	40	M36x2	M30x2	72	75	60	36	16	39	6	56	95

\*NOTE: Dimensions do not apply to Rod Lock Versions.

With MF1 Mounting



"Special Thread" Style 3

Special thread, extension, rod eye, blank, etc are also available. To order, specify "Style 3" and provide desired dimensions for KF or KK, AM and WH. If otherwise special, furnish dimensioned sketch.

Bore size	D	KK	KF	AM	SW across flats	L12	MF	NA	L2	W†	WH†
32	12	M10x1.25	M8x1	22	10	6	10	11	18	16	26
40	16	M12x1.25	M10x1.25	24	13	6.5	10	15	20	20	30
50	20	M16x1.5	M14x1.5	32	17	6.5	12	19	26	25	37
63	20	M16x1.5	M14x1.5	32	17	6.5	12	19	26	25	37
80	25	M20x1.5	M18x1.5	40	22	10	16	24	33	30	46
100	25	M20x1.5	M18x1.5	40	22	10	16	24	33	35	51
125	32	M27x2	M24x2	54	27	13	20	31	41	45	65
160	40	M36x2	M30x2	72	36	16	20	39	56	60	80
200	40	M36x2	M30x2	72	36	16	25	39	56	70	95

\*NOTE: Dimensions do not apply to Rod Lock Versions.

**B**  
 Tie Rod Pneumatic Cylinders  
 4MA Series  
 4MAJ Series  
 2MNR Series  
 ACVB Option  
 LPSO Option  
 P1D Series



For inventory, lead time, and kit lookup, visit [www.pdnplu.com](http://www.pdnplu.com)

B121

**Parker Hannifin Corporation**  
 Pneumatic Division  
 Richland, Michigan  
[www.parker.com/pneumatics](http://www.parker.com/pneumatics)

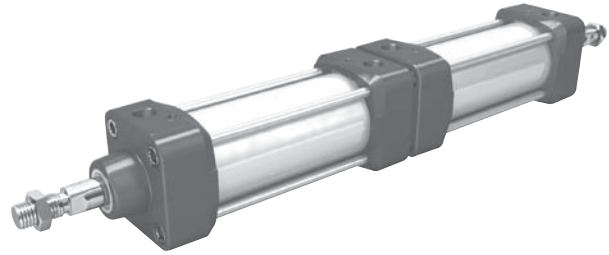
**Duplex & Tandem Cylinders**

**3 and 4-Position Duplex Cylinders**

This type of cylinder function can consist of two cylinders installed back to back. Two cylinders with the same stroke result in a 3-position cylinder with a symmetrical center position, whereas two different strokes result in a 4-position cylinder where the two central positions can be calculated from the different stroke lengths.

A 3-position duplex cylinder can also be obtained by mounting two cylinders of different strokes, in series, but not connecting the piston rods together. This concept is illustrated in a guided cylinder application shown on page F142 of the HB series.

These 3 and 4-position cylinders can be ordered in two ways as follows.



**Factory-fitted P1D Duplex Cylinders**

P1D tie-rod version duplex cylinders are completed at the factory and are joined together as one unit by special tie-rods. This version needs to be ordered as a special (/). Please consult factory for assistance.

**Customer-Installed Mounting Kit**

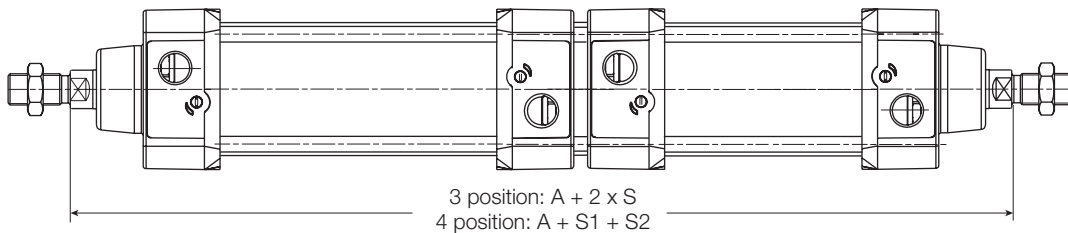
There is an installation mounting kit available for cylinder bores 32-100mm which makes it possible to join any two P1D cylinders, of the same bore, together at any time to make a 3 or 4-position cylinder. Please refer to the cylinder mountings on top of page B127.

**Tandem Cylinders**

In addition to the duplex cylinder options above, the P1D tie-rod version is also available as a tandem cylinder. By ordering two cylinders of equal strokes, mounted in series, and connecting the piston rods together, you achieve almost twice the output force, at the same pressure, as a standard cylinder. This is a great advantage when restricted mounting space prevents the use of a larger bore cylinder. Please review version and function options in the model code on page B97.

Cylinder Bore	A (mm)	
	P1D-T	P1D-B
32	247	256
40	277	286
50	293	306
63	323	336
80	355	373
100	385	403
125	461	-

S = Stroke



**P**  
Tie Rod Pneumatic Cylinders

4MA Series

4MAJ Series

2MNR Series

ACVB Option

LPSO Option

P1D Series



For inventory, lead times, and kit lookup, visit [www.pdnplu.com](http://www.pdnplu.com)

**Flange – MF1, MF2**

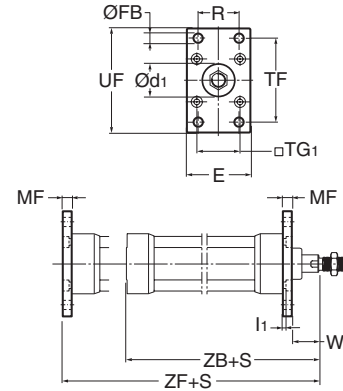


Intended for fixed mounting of cylinder. Flange can be fitted to front or rear end cover of cylinder.

**Materials:**

- 32-100mm bore flange: Surface-treated aluminum, black
- 125-200mm bore flange: Steel, black
- Mounting screws acc. to DIN 6912: Zinc-plated steel 8.8

Supplied complete with mounting screws for attachment to cylinder.



**According to ISO MF1/MF2, VDMA 24 562, AFNOR**

Bore size mm	d1 H11 mm	FB H13 mm	TG1 mm	E mm	R JS14 mm	MF JS14 mm	TF JS14 mm	UF	l1 -0.5 mm	W mm	ZF mm	ZB mm	Weight kg	Part number
32	30	7	32.5	45	32	10	64	80	5.0	16	130	123.5	0.23	P1C-4KMBA
40	35	9	38.0	52	36	10	72	90	5.0	20	145	138.5	0.28	P1C-4LMBA
50	40	9	46.5	65	45	12	90	110	6.5	25	155	146.5	0.53	P1C-4MMBA
63	45	9	56.5	75	50	12	100	120	6.5	25	170	161.5	0.71	P1C-4NMB
80	45	12	72.0	95	63	16	126	150	8.0	30	190	177.5	1.59	P1C-4PMBA
100	55	14	89.0	112	75	16	150	185	8.0	35	205	192.5	2.19	P1C-4QMBA
125	60	16	110.0	140	90	20	188	220	10.5	45	245	230.5	3.78	P1C-4RMB
160	65	18	140.0	180	115	20	230	260	9.5	60	280	266	C.F.	L075370160
200	75	22	175.0	220	135	25	270	300	12.5	70	300	281	C.F.	L075370200

S = Stroke length C.F. = Consult Factory

**Foot Bracket – MS1**

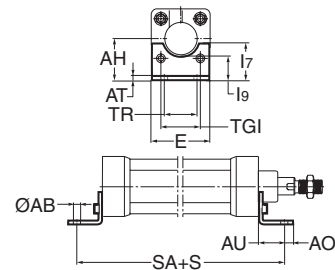


Intended for fixed mounting of cylinder. Foot bracket can be fitted to front and rear end covers of cylinder.

**Materials:**

- Foot bracket: Surface-treated steel, black
- Mounting screws acc. to DIN 912: Zinc-plated steel 8.8

Supplied in pairs with mounting screws for attachment to cylinder.



**According to ISO MS1, VDMA 24 562, AFNOR**

Bore size mm	AB H14 mm	TG1 mm	E mm	TR JS14 mm	AO mm	AU mm	AH JS15 mm	l7 mm	AT mm	l9 JS14 mm	SA mm	Weight* kg	Part number
32	7	32.5	45	32	10	24	32	30	4.5	17.0	142	0.06	P1C-4KMF
40	9	38.0	52	36	8	28	36	30	4.5	18.5	161	0.08	P1C-4LMF
50	9	46.5	65	45	13	32	45	36	5.5	25.0	170	0.16	P1C-4MMF
63	9	56.5	75	50	13	32	50	35	5.5	27.5	185	0.25	P1C-4NMF
80	12	72.0	95	63	14	41	63	49	6.5	40.5	210	0.50	P1C-4PMF
100	14	89.0	115	75	15	41	71	54	6.5	43.5	220	0.85	P1C-4QMF
125	16	110.0	140	90	22	45	90	71	8.0	60.0	250	1.48	P1C-4RMF
160	18	140.0	180	115	15	60	115	100	9.0	63.5	300	C.F.	L075380160
200	22	175.0	220	135	30	70	135	100	12.0	65.0	320	C.F.	L075380200

S = Stroke length C.F. = Consult Factory

\*Weight per item



For inventory, lead time, and kit lookup, visit [www.pdnplu.com](http://www.pdnplu.com)

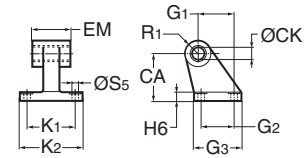
**Pivot Bracket with Rigid Bearing**



Intended for flexible mounting of cylinder. The pivot bracket can be combined with clevis bracket MP2.

**Materials:**

Pivot bracket: Surface-treated aluminium, black  
Bearing: Sintered oil-bronze bushing



**According to CETOP RP 107 P, VDMA 24 562, AFNOR**

Bore size mm	CK H9 mm	S5 H13 mm	K1 JS14 mm	K2	G1 JS14 mm	G2 JS14 mm	EM mm	G3 mm	CA JS15 mm	H6 mm	R1 mm	Weight kg	Part number
32	10	6.6	38	51	21	18	25.5	31	32	8	10.0	0.06	<b>P1C-4KMD</b>
40	12	6.6	41	54	24	22	27.0	35	36	10	11.0	0.08	<b>P1C-4LMD</b>
50	12	9.0	50	65	33	30	31.0	45	45	12	13.0	0.15	<b>P1C-4MMD</b>
63	16	9.0	52	67	37	35	39.0	50	50	12	15.0	0.20	<b>P1C-4NMD</b>
80	16	11.0	66	86	47	40	49.0	60	63	14	15.0	0.33	<b>P1C-4PMD</b>
100	20	11.0	76	96	55	50	59.0	70	71	15	19.0	0.49	<b>P1C-4QMD</b>
125	25	14.0	94	124	70	60	69.0	90	90	20	22.5	1.02	<b>P1C-4RMD</b>
160	30	14.0	118	156	97	89	88.5	126	115	25	31.0	C.F.	<b>L075480160</b>
200	30	16.0	122	162	105	89	88.5	130	135	30	31.0	C.F.	<b>L075480200</b>

C.F. = Consult Factory

**Swivel Eye Bracket – MP6**

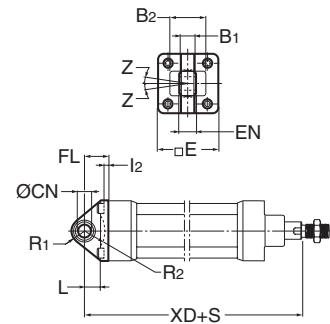


Intended for use together with clevis bracket GA

**Materials:**

Bracket: Surface-treated aluminium, black  
(Cast iron for 160-200mm bores)  
Swivel bearing acc. to DIN 648K: Hardened steel

Supplied complete with mounting screws for attachment to cylinder.



**According to VDMA 24 562, AFNOR**

Bore size mm	E mm	B1 mm	B2 mm	EN mm	R1 mm	R2 mm	FL mm	l2 mm	L mm	CN H7 mm	XD mm	Z	Weight kg	Part number
32	45	10.5	-	14	16	-	22	5.5	12	10	142	4°	0.08	<b>P1C-4KMSA</b>
40	52	12.0	-	16	18	-	25	5.5	15	12	160	4°	0.11	<b>P1C-4LMSA</b>
50	65	15.0	51	21	21	19	27	6.5	15	16	170	4°	0.20	<b>P1C-4MMSA</b>
63	75	15.0	-	21	23	-	32	6.5	20	16	190	4°	0.27	<b>P1C-4NMSA</b>
80	95	18.0	-	25	29	-	36	10.0	20	20	210	4°	0.52	<b>P1C-4PMSA</b>
100	115	18.0	-	25	31	-	41	10.0	25	20	230	4°	0.72	<b>P1C-4QMSA</b>
125	140	25.0	-	37	40	-	50	10.0	30	30	275	4°	1.53	<b>P1C-4RMSA</b>
160	177	30.0	-	43	44	41	55	4.0	41	35	315	16°	C.F.	<b>L075420160</b>
200	214	30.0	-	43	48	42	60	8.0	42	35	335	16°	C.F.	<b>L075420200</b>

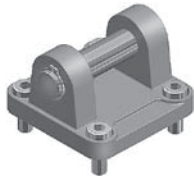
S = Stroke length C.F. = Consult Factory



For inventory, lead times, and kit lookup, visit [www.pdnplu.com](http://www.pdnplu.com)



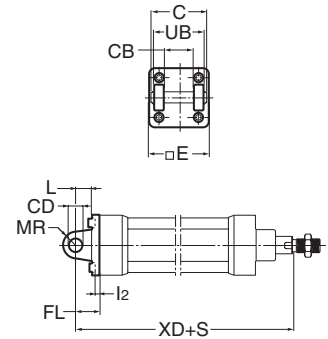
**Clevis Bracket – MP2**



Intended for flexible mounting of cylinder. Clevis bracket MP2 can be combined with clevis bracket MP4.

**Materials:**

Clevis bracket: Surface-treated aluminium, black for 32-160mm bores; Cast iron for 200mm bore  
 Pin: Surface hardened steel  
 Circlips according to DIN 471: Spring steel  
 Mounting screws acc. to DIN 912: Zinc-plated steel 8.8  
 Supplied complete with mounting screws for attachment to cylinder.

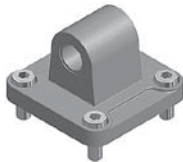


**According to ISO MP2, VDMA 24 562, AFNOR**

Bore size mm	C mm	E mm	UB H14 mm	CB H14 mm	FL ±0.2 mm	L mm	l2 mm	CD H9 mm	MR mm	XD mm	Weight kg	Part number
32	53	45	45	26	22	13	5.5	10	10	142	0.08	P1C-4KMT
40	60	52	52	28	25	16	5.5	12	12	160	0.11	P1C-4LMT
50	68	65	60	32	27	16	6.5	12	12	170	0.14	P1C-4MMT
63	78	75	70	40	32	21	6.5	16	16	190	0.29	P1C-4NMT
80	98	95	90	50	36	22	10.0	16	16	210	0.36	P1C-4PMT
100	118	115	110	60	41	27	10.0	20	20	230	0.64	P1C-4QMT
125	139	140	130	70	50	30	10.0	25	25	275	1.17	P1C-4RMT

S = Stroke length C.F. = Consult Factory

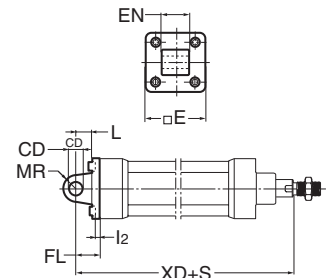
**Clevis Bracket – MP4**



Intended for flexible mounting of cylinder. Clevis bracket MP4 can be combined with clevis bracket MP2.

**Materials:**

Clevis bracket: Surface-treated aluminium, black for 32-125mm bores; Cast iron for 160-200mm bores  
 Mounting screws acc. to DIN 912: Zinc-plated steel 8.8  
 Supplied complete with mounting screws for attachment to cylinder.



**According to ISO MP4, VDMA 24 562, AFNOR**

Bore size mm	E mm	EW mm	FL mm	L ±0.2 mm	l2 mm	CD mm	MR H9 mm	XD mm	Weight kg	Part number
32	45	26	22	13	5.5	10	10	142	0.09	P1C-4KME
40	52	28	25	16	5.5	12	12	160	0.13	P1C-4LME
50	65	32	27	16	6.5	12	12	170	0.17	P1C-4MME
63	75	40	32	21	6.5	16	16	190	0.36	P1C-4NME
80	95	50	36	22	10.0	16	16	210	0.46	P1C-4PME
100	115	60	41	27	10.0	20	20	230	0.83	P1C-4QME
125	140	70	50	30	10.0	25	25	275	1.53	P1C-4RME
160	180	90	55	35	10.0	30	25	315	C.F.	L075410160
200	220	90	60	35	14.0	30	25	335	C.F.	L075410200

S = Stroke length C.F. = Consult Factory

**B**

Tie Rod Pneumatic Cylinders

4MA Series

4MAJ Series

2MNR Series

ACVB Option

LPSO Option

P1D Series



For inventory, lead time, and kit lookup, visit [www.pdnplu.com](http://www.pdnplu.com)

B125

**Parker Hannifin Corporation**  
 Pneumatic Division  
 Richland, Michigan  
[www.parker.com/pneumatics](http://www.parker.com/pneumatics)

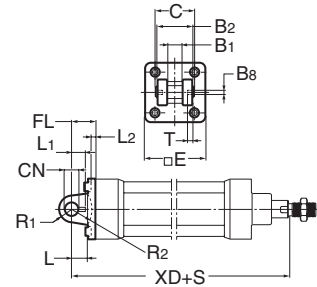
**Clevis Bracket – GA**



Intended for flexible mounting of cylinder. Clevis bracket GA can be combined with pivot bracket with swivel bearing, swivel eye bracket and swivel rod eye.

**Materials:**

- Clevis bracket: Surface-treated aluminium
  - Pin: Surface hardened steel
  - Locking pin: Spring steel
  - Circlips according to DIN 471: Spring steel
  - Mounting screws acc. to DIN 912: Zinc-plated steel 8.8
- Supplied complete with mounting screws for attachment to cylinder.

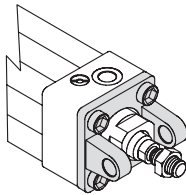


**According to VDMA 24 562, AFNOR**

Bore size mm	C mm	E mm	B2 d12 mm	B1 H14 mm	T mm	B3 mm	R2 mm	L1 mm	FL ±0.2 mm	I2 mm	L mm	CN F7 mm	R1 mm	XD mm	Weight kg	Part number
32	41	45	34	14	3	3.3	17	11.5	22	5.5	12	10	11	142	0.09	P1C-4KMCA
40	48	52	40	16	4	4.3	20	12.0	25	5.5	15	12	13	160	0.13	P1C-4LMCA
50	54	65	45	21	4	4.3	22	14.0	27	6.5	17	16	18	170	0.17	P1C-4MMCA
63	60	75	51	21	4	4.3	25	14.0	32	6.5	20	16	18	190	0.36	P1C-4NMCA
80	75	95	65	25	4	4.3	30	16.0	36	10.0	20	20	22	210	0.58	P1C-4PMCA
100	85	115	75	25	4	4.3	32	16.0	41	10.0	25	20	22	230	0.89	P1C-4QMCA
125	110	140	97	37	6	6.3	42	24.0	50	10.0	30	30	30	275	1.75	P1C-4RMCA

S = Stroke length C.F. = Consult Factory

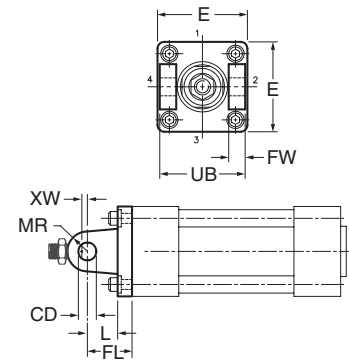
**Head Detachable Clevis – MP7**



Intended for flexible mounting of cylinder

**Materials:**

- Clevis bracket: Cast iron for 32-63mm bores;
  - Surface treated aluminum, black for 80-200mm bores
  - Mounting screws acc. to DIN 912: Zinc-plated steel 8.8
- Supplied complete with mounting screws for attachment to cylinder.



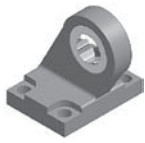
**According to ISO MP7, VDMA 24 562, AFNOR**

Bore size mm	CD mm	E mm	FL mm	FW mm	L mm	MR mm	UB mm	XW mm	Part number
32	10	46.5	22	8	12	10	45	4	L075400032
50	12	63.5	27	10	15	13	60	10	L075400050
63	16	76	32	15	20	16	70	5	L075400063
125	25	140	50	30	35	25	130	15	L075400125
160	30	177	55	40	36	30	170	25	L075400160



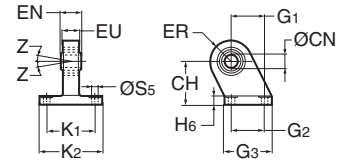
For inventory, lead times, and kit lookup, visit [www.pdnplu.com](http://www.pdnplu.com)

**Pivot Bracket with Swivel Bearing**



Intended for use together with clevis bracket GA.

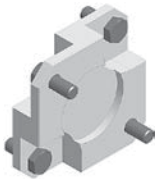
**Materials:**  
Pivot bracket: Surface-treated steel, black  
Swivel bearing acc. to DIN 648K: Hardened steel



**According to VDMA 24 562, AFNOR**

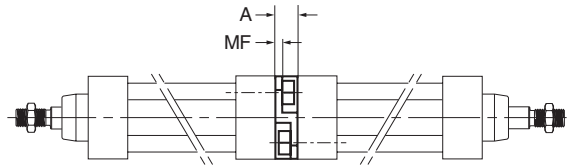
Bore size mm	CN H7 mm	S5 H13 mm	K1 JS14 mm	K2 mm	EU mm	G1 JS14 mm	G2 JS14 mm	EN mm	G3 mm	CH JS15 mm	H6 mm	ER mm	Z	Weight kg	Part number
32	10	6.6	38	51	10.5	21	18	14	31	32	10	16	4°	0.18	<b>P1C-4KMA</b>
40	12	6.6	41	54	12.0	24	22	16	35	36	10	18	4°	0.25	<b>P1C-4LMA</b>
50	16	9.0	50	65	15.0	33	30	21	45	45	12	21	4°	0.47	<b>P1C-4MMA</b>
63	16	9.0	52	67	15.0	37	35	21	50	50	12	23	4°	0.57	<b>P1C-4NMA</b>
80	20	11.0	66	86	18.0	47	40	25	60	63	14	28	4°	1.05	<b>P1C-4PMA</b>
100	20	11.0	76	96	18.0	55	50	25	70	71	15	30	4°	1.42	<b>P1C-4QMA</b>
125	30	14.0	94	124	25.0	70	60	37	90	90	20	40	4°	3.10	<b>P1C-4RMA</b>

**Mounting Kit**

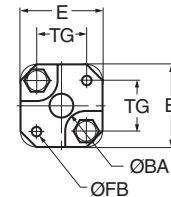


Mounting kit for back to back mounted cylinders, 3 and 4 position duplex cylinders.

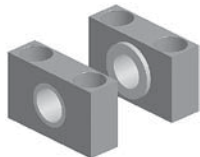
**Materials:**  
Mounting: Aluminium  
Mounting screws: Zinc-plated steel 8.8



Bore size mm	E mm	TG mm	ØFB mm	MF mm	A mm	ØBA mm	Weight kg	Part number
32	50	32.5	6.5	5	16	30	0.060	<b>P1E-6KB0</b>
40	60	38.0	6.5	5	16	35	0.078	<b>P1E-6LB0</b>
50	66	46.5	8.5	6	20	40	0.162	<b>P1E-6MB0</b>
63	80	56.5	8.5	6	20	45	0.194	<b>P1E-6NB0</b>
80	100	72.0	10.5	8	25	45	0.450	<b>P1E-6PB0</b>
100	118	89.0	10.5	8	25	55	0.672	<b>P1E-6QB0</b>

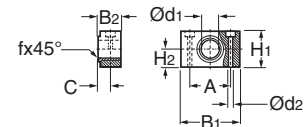


**Pivot Bracket – MT4**



Intended for use together with central trunnion MT4.

**Materials:**  
Pivot bracket: Surface-treated aluminium  
Bearing acc. to DIN 1850 C: Sintered oil-bronze bushing  
Supplied in pairs.



**According to ISO, VDMA 24 562, AFNOR**

Bore size mm	B1 mm	B2 mm	A mm	C mm	d1 mm	d2 H13 mm	H1 mm	H2 mm	fx45° min mm	Weight* kg	Part number
32	46	18.0	32	10.5	12	6.6	30	15	1.0	0.04	<b>9301054261</b>
40	55	21.0	36	12.0	16	9.0	36	18	1.6	0.07	<b>9301054262</b>
50	55	21.0	36	12.0	16	9.0	36	18	1.6	0.07	<b>9301054263</b>
63	65	23.0	42	13.0	20	11.0	40	20	1.6	0.12	<b>9301054264</b>
80	65	23.0	42	13.0	20	11.0	40	20	1.6	0.12	<b>9301054265</b>
100	75	28.5	50	16.0	25	14.0	50	25	2.0	0.21	<b>9301054266</b>
125	75	28.5	50	16.0	25	14.0	50	25	2.0	0.21	<b>9301054267</b>

\* Weight per item

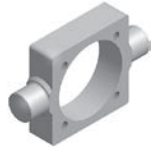


For inventory, lead time, and kit lookup, visit [www.pdnplu.com](http://www.pdnplu.com)

**Intermediate Trunnion – MT4**



Standard\*

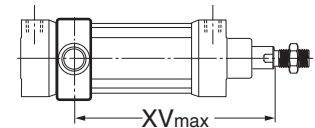
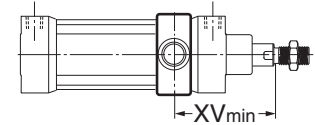
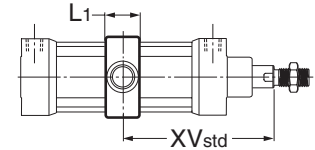
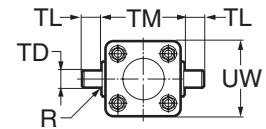


Tie Rod Version

Intended for articulated mounting of cylinder. The trunnion is factory-fitted at an optional location. Order by specifying Mounting Style G or 7 and providing the desired XV dimension (3-digit measure in mm). See page B97 for ordering information. Combined with pivot bracket for MT4 for 32-125mm bores.

**Materials:**  
Trunnion: Zinc plated steel  
(Cast iron for 160-200mm bores)

\* Standard mounting is for the Standard cylinder body and is permanently affixed by the factory.



XV Standard for Rod Lock version:  

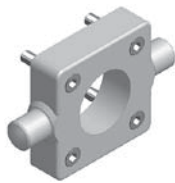
$$\frac{L8 + \text{Stroke} + WH}{2}$$

**According to ISO MT4, VDMA 24 562, AFNOR**

Bore size mm	TM h14 mm	TL h14 mm	TD e9 mm	R mm	UW mm	L1 mm	X1 mm	Standard "G"		Standard "7"		Tie Rod		Weight kg
								XVmin mm	X2 mm	XVmin mm	X2 mm	XVmin mm	X2 mm	
32	50	12	12	1.0	46	15	73.0	70.0	76.0	84.0	62.0	84.0	0.13	
40	63	16	16	1.6	59	20	82.5	83.0	82.0	91.0	74.0	73.0	92.0	0.31
50	75	16	16	1.6	69	20	90.0	90.5	89.5	108.5	71.5	80.5	99.5	0.37
63	90	20	20	1.6	84	25	97.5	99.0	93.5	111.0	84.0	89.5	106.0	0.69
80	110	20	20	1.6	102	25	110.0	108.0	109.5	125.0	95.0	98.0	122.0	0.89
100	132	25	25	2.0	125	30	120.0	120.5	114.5	132.5	107.5	110.5	129.5	1.58
125	160	25	25	2.0	155	32	145.0	142.0	142.0	160.0	130.0	132.0	158.0	2.60
160	200	32	32	2.5	190	70	C.F.	-	-	-	-	169	C.F.	C.F.
200	250	32	32	2.5	242	70	C.F.	-	-	-	-	184	C.F.	C.F.

XVstd = X1 + Stroke length/2      XVmax = X2 + Stroke length      C.F. = Consult Factory

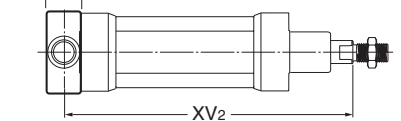
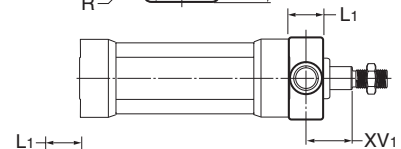
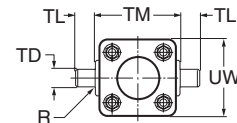
**Flange Mounted Trunnion, J or H**



Intended for articulated mounting of cylinder. This trunnion can be flange mounted on the front or rear end cover of all P1D cylinders. If you choose, you can order a complete cylinder with factory-fitted flange mounted trunnion – see the ordering information on page B67 Individual trunnions have part numbers as shown below.

**Materials:**  
Trunnion: zinc plated steel  
Screws: zinc plated steel, 8.8

Delivered complete with mounting screws for attachment to the cylinder



**According to ISO MT4, VDMA 24 562, AFNOR**

Bore size mm	TM h14 mm	TL h14 mm	TD e9 mm	R mm	UW mm	L1 mm	XV <sub>1</sub> mm	X mm	Weight kg	Part number
32	50	12	12	1.0	46	14	19.0	127.0	0.17	P1D-4KMYF
40	63	16	16	1.6	59	19	20.5	144.5	0.43	P1D-4LMYF
50	75	16	16	1.6	69	19	27.5	152.5	0.55	P1D-4MMYF
63	90	20	20	1.6	84	24	25.0	170.0	1.10	P1D-4NMYF
80	110	20	20	1.6	102	24	34.0	186.0	1.66	P1D-4PMYF
100	132	25	25	2.0	155	29	36.5	203.5	3.00	P1D-4QMYF

XV<sub>2</sub> = X + Stroke length



For inventory, lead times, and kit lookup, visit [www.pdnplu.com](http://www.pdnplu.com)

**Swivel Rod Eye**



**Stainless Steel  
Swivel Rod Eye**

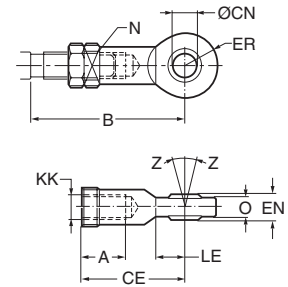
Swivel rod eye for articulated mounting of cylinder.  
Swivel rod eye can be combined with clevis bracket GA.  
Maintenance-free.

**Materials:**

Swivel rod eye: Zinc-plated steel  
Swivel bearing according to DIN 648K: Hardened steel

Swivel rod eye: Stainless steel 304  
Swivel bearing according to DIN 648K: Stainless steel

Use stainless steel nut (see next page) with stainless steel swivel rod eye.



**According to ISO 8139**

Bore size mm	A mm	B min mm	B max mm	CE mm	CN H9 mm	EN h12 mm	ER mm	KK	LE min mm	N mm	O mm	Z	Weight kg	Part number	Stainless steel part number
32	20	48.0	55	3	10	14	14	M10x1.25	15	17	10.5	12°	0.08	P1C-4KRS	P1S-4JRT
40	22	56.0	62	50	12	16	16	M12x1.25	17	19	12.0	12°	0.12	P1C-4LRS	P1S-4LRT
50	28	72.0	80	64	16	21	21	M16x1.5	22	22	15.0	15°	0.25	P1C-4MRS	P1S-4MRT
63	28	72.0	80	64	16	21	21	M16x1.5	22	22	15.0	15°	0.25	P1C-4PRS	P1S-4PRT
80	33	87.0	97	77	20	25	25	M20x1.5	26	32	18.0	15°	0.46	P1C-4RRS	P1S-4RRT
100	33	87.0	97	77	20	25	25	M20x1.5	26	32	18.0	15°	0.46	P1C-4RRS	P1S-4RRT
125	51	123.5	137	110	30	37	35	M27x2	36	41	25.0	15°	1.28	P1C-4RRS	P1S-4RRT
160/200	56	C.F.	C.F.	125	35*	43	40	M36x2	40	50	28.0	15°	C.F.	P1C-4SRS	—

\*H7 C.F. = Consult Factory

**Clevis**



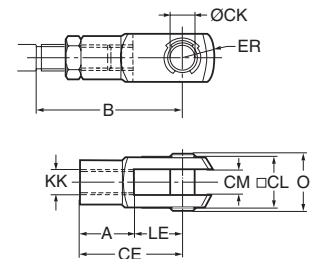
**Stainless Steel  
Clevis**

Clevis for articulated mounting of cylinder.

**Materials:**

Clevis, clip: Galvanized steel  
Pin: Hardened steel

Clevis: Stainless steel  
Pin: Stainless steel  
Circlips according to DIN 471: Stainless steel



**According to ISO 8140**

Bore size mm	A mm	B min mm	B max mm	CE mm	CK h11/E9 mm	CL mm	CM mm	ER mm	KK	LE mm	O mm	Weight kg	Part number	Stainless steel part number
32	20	45.0	52	40	10	20	10	16	M10x1.25	20	28.0	0.09	P1C-4KRC	P1S-4JRD
40	24	54.0	60	48	12	24	12	19	M12x1.25	24	32.0	0.15	P1C-4LRC	P1S-4LRD
50	32	72.0	80	64	16	32	16	25	M16x1.5	32	41.5	0.35	P1C-4MRC	P1S-4MRD
63	32	72.0	80	64	16	32	16	25	M16x1.5	32	41.5	0.35	P1C-4MRC	P1S-4MRD
80	40	90.0	100	80	20	40	20	32	M20x1.5	40	50.0	0.75	P1C-4PRC	P1S-4PRD
100	40	90.0	100	80	20	40	20	32	M20x1.5	40	50.0	0.75	P1C-4PRC	P1S-4PRD
125	56	123.5	137	110	30	55	30	45	M27x2	54	72.0	2.10	P1C-4RRC	P1S-4RRD
160/200	71	C.F.	C.F.	144	35	70	35	57	M36x2	72	95	C.F.	L075490036	Consult factory

C.F. = Consult Factory

**B**

Tie Rod Pneumatic Cylinders

4MA Series

4MAJ Series

2MNR Series

ACVB Option

LPSO Option

P1D Series



For inventory, lead time, and kit lookup, visit [www.pdnplu.com](http://www.pdnplu.com)

B129

**Parker Hannifin Corporation**  
Pneumatic Division  
Richland, Michigan  
[www.parker.com/pneumatics](http://www.parker.com/pneumatics)

**Flexo Coupling**

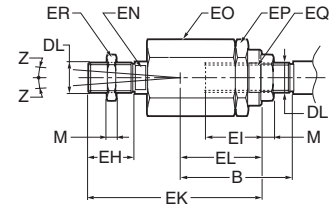


Flexo coupling for articulated mounting of piston rod. Flexo fitting is intended to take up axial angle errors within a range of  $\pm 4^\circ$ .

**Materials:**

Flexo coupling, nut: Zinc-plated steel  
Socket: Hardened steel

Supplied complete with galvanized adjustment nut.



Bore size mm	B min mm	B max mm	DL	EH mm	EI mm	EK mm	EL mm	EN mm	EO mm	EP mm	EQ mm	ER mm	M mm	Z	Weight kg	Part number
32	36.0	43	M10x1.25	20	23	70	31	12	30	30	19	30	5.0	4°	0.21	<b>P1C-4KRF</b>
40	37.0	43	M12x1.25	23	23	77	31	12	30	30	19	30	6.0	4°	0.22	<b>P1C-4LRF</b>
50	53.0	61	M16x1.5	40	32	112	45	19	41	41	30	41	8.0	4°	0.67	<b>P1C-4MRF</b>
63	53.0	61	M16x1.5	40	32	112	45	19	41	41	30	41	8.0	4°	0.67	<b>P1C-4MRF</b>
80	57.0	67	M20x1.5	39	42	122	56	19	41	41	30	41	10.0	4°	0.72	<b>P1C-4PRF</b>
100	57.0	67	M20x1.5	39	42	122	56	19	41	41	30	41	10.0	4°	0.72	<b>P1C-4PRF</b>
125	75.5	89	M27x2	48	48	145	60	24	55	55	32	55	13.5	4°	1.80	<b>P1C-4RRF</b>
160/200	C.F.	C.F.	M36x2	72	78	251	C.F.	36	75	75	50	55	18.0	4°	C.F.	<b>KY1139</b>

C.F. = Consult Factory

**Nuts**



Intended for fixed mounting of accessories to the piston rod.

**Material:** Zinc-plated steel

All P1D cylinders are delivered with a zinc-plated steel piston rod nut.

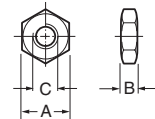
**Stainless Steel Nut**

**Material:** Stainless steel A2

**Acid-proof nut**

**Material:** Acid-proof steel A4

Cylinders with acid-proof piston rod are supplied with nut of acid-proof steel.



**According to DIN 439 B**

Bore size mm	A mm	B mm	C	Weight kg	Part numbers		
					Steel	Stainless steel	Acid-proof
32	17	5.0	M10x1.25	0.007	<b>0867340300</b>	<b>9126725404</b>	<b>0261109919</b>
40	19	6.0	M12x1.25	0.010	<b>0867340400</b>	<b>9126725405</b>	<b>0261109920</b>
50	24	8.0	M16x1.5	0.021	<b>0867340600</b>	<b>9126725406</b>	<b>0261109917</b>
63	24	8.0	M16x1.5	0.021			
80	30	10.0	M20x1.5	0.040	<b>0261109911</b>	<b>0261109921</b>	<b>0261109916</b>
100	30	10.0	M20x1.5	0.040			
125	41	13.5	M27x2	0.100	<b>0867340900</b>	<b>0261109922</b>	<b>0261109918</b>
160/200	55	18.0	M36x2	C.F.	<b>L075540036</b>	Consult factory	Consult factory

C.F. = Consult Factory



For inventory, lead times, and kit lookup, visit [www.pdnplu.com](http://www.pdnplu.com)

**Screw Set for MP2, MP4, MS1 and GA**



Set of stainless steel screws for fitting clevis brackets MP2, MP4 and GA onto the cylinder. The screws have an internal hexagonal head and are used in special environments, e.g. the food industry, or where there are extra demands for protection against corrosion.

Material:  
 According to DIN 912, Stainless steel, A2

4 pcs per pack.

Bore mm	Weight kg	Part number
32	0.02	9301054321
40	0.02	9301054321
50	0.05	9301054322
63	0.05	9301054322
80	0.09	9301054323
100	0.09	9301054323
125	0.15	9301054324

**Screw Set for MF1/MF2**



Set of stainless steel screws for fitting flanges MF1/MF2 onto the cylinder. The screws have an internal hexagonal head and are used in special environments, e.g. the food industry, or where there are extra demands for protection against corrosion.

Material:  
 According to DIN 6912, Stainless steel, A2

4 pcs per pack

Bore mm	Weight kg	Part number
32	0.02	9301054331
40	0.02	9301054331
50	0.04	9301054332
63	0.04	9301054332
80	0.07	9301054333
100	0.07	9301054333
125	0.12	9301054334

**Sealing Plugs**



Set of sealing plugs to be fitted in unused end covers. The plugs can be used for all P1D cylinders to avoid collecting dirt and fluids in the end cover screw recesses.

Material:  
 Polyamid PA

4 pcs per pack

Bore mm	Weight kg	Part number
32	0.01	9121742201
40	0.01	9121742201
50	0.02	9121742202
63	0.02	9121742202
80	0.02	9121742203
100	0.02	9121742203
125	0.03	9121742204

**B**

Tie Rod Pneumatic Cylinders

4MA Series

4MAJ Series

2MNR Series

ACVB Option

LPSO Option

P1D Series

**Service Kits: P1D-B, P1D-T, P1D-C,  
and P1D-F Versions**

Cylinder bore mm	P1D cylinder version Consisting of: piston, rod and o-ring seals
32	SK032P1D01
40	SK040P1D01
50	SK050P1D01
63	SK063P1D01
80	SK080P1D01
100	SK100P1D01
125	SK125P1D01

**Grease for P1D Series**



Size	Part number
30g (standard)	9127394541

**Gland Service Kits: P1D-G and P1D-E Versions**

Bore size mm	Rod dia. mm	Rod no.	RG-rod gland cartridge kit Consisting of: rod gland, seals, and wiper		RK-rod seal kit Consisting of: gland seals, and wiper	
			Nitrile seals part number	Fluorocarbon seals part number	Nitrile seals part number	Fluorocarbon seals Part number
32	12	1	RG0P1D0121	RG0P1D0125	RK0P1D0121	RK0P1D0125
40	16	1	RG0P1D0161	RG0P1D0165	RK0P1D0161	RK0P1D0165
50 & 63	20	1	RG0P1D0201	RG0P1D0205	RK0P1D0201	RK0P1D0205
80 & 100	25	1	RG0P1D0251	RG0P1D0255	RK0P1D0251	RK0P1D0255
125	32	1	RG0P1D0321	RG0P1D0325	RK0P1D0321	RK0P1D0325

**Piston and End Seal Service Kits: P1D-G and P1D-E Versions**

Bore size mm	PK – piston seal kit Consisting of: piston seals, wear ring, and magnetic strip (nitrile only)		CB – cylinder body end seal kit Consisting of: end seal o-rings	
	Nitrile seals part number	Fluorocarbon seals part number	Nitrile seals part number	Fluorocarbon seals part number
32	PK032P1D01	PK032P1D05	CB032P1D01	CB032P1D05
40	PK040P1D01	PK040P1D05	CB040P1D01	CB040P1D05
50	PK050P1D01	PK050P1D05	CB050P1D01	CB050P1D05
63	PK063P1D01	PK063P1D05	CB063P1D01	CB063P1D05
80	PK080P1D01	PK080P1D05	CB080P1D01	CB080P1D05
100	PK100P1D01	PK100P1D05	CB100P1D01	CB100P1D05
125	PK125P1D01	PK125P1D05	CB125P1D01	CB125P1D05

**B**  
Tie Rod Pneumatic Cylinders

Series  
4MA  
4MAJ  
2MNR  
Option  
ACVB  
Option  
LPSO  
Series  
P1D



For inventory, lead times, and kit lookup, visit [www.pdnplu.com](http://www.pdnplu.com)



**Round Body Design  
Pneumatic Cylinders**

**SR/SRM, SRD/SRDM Series - , Stainless Steel Body**

Features	C2-C3
Ordering Information	C3
Mounting Styles	C4
Specifications	C5
Technical Data	C6
Dimensional Data	C7-28
Air Reservoirs	C29
Options	C30
Adjustable Cushion Option	C31
Accessories	C32-C33



**SRG/SRGM Series with Stainless Caps**

Features	C34
Ordering Information	C34
Dimensional Data	C35
Mounting Style	C36
Accessories	C37



**SRX Series with Continuous Position Feedback**

Features	C38-C39
Ordering Information	C39
Mounting Styles	C40
Specifications	C40-C41
Dimensional Data	C42-C45
Accessories	C47
Connector Options	C48
Electrical Accessories	C49



**P1A Series - Mini ISO 6432, Stainless Steel**

Features	C50-C51
Ordering Information / Stroke Lengths	C51
Specifications	C52-C54
Dimensional Data	C55
Accessories	C56-C57



**P Series - Aluminum**

Features	C58-C59
Ordering Information	C59
Specifications	C60
Mountings	C60
Dimensional Data	C61
Sensor Mounting / Service Kits	C66



For inventory, lead time, and kit lookup, visit [www.pdnplu.com](http://www.pdnplu.com)

**SR Series**

**STAINLESS STEEL  
PISTON RODS**

Corrosion resistant stainless steel is now the standard piston rod material for all bore sizes up to and including 1.50 inch bore at no additional cost. The only exception to the stainless steel standard is when a hollow rod or non-rotating hexagonal rod option is specified. Stainless steel is also the standard material on block, trunnion and KDX mounts.

**PRE-LUBRICATION**

All SR Series cylinders are factory prelubricated for use with or without added lubrication.

**ROD BUSHINGS**

Oil impregnated bronze, reamed to a close tolerance provides for smooth operation and long life.

**SEALS**

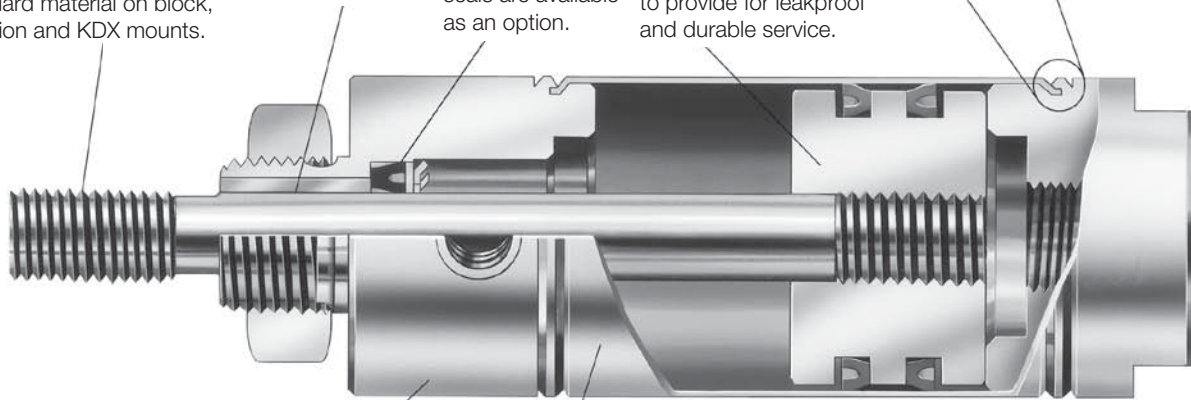
All piston and rod seals are of a lipseal construction. Buna-N is standard on all models. Fluorocarbon seals are available as an option.

**PISTON BODY**

Pistons are precision machined aluminum construction. Piston rod connections are threaded and loctited to provide for leakproof and durable service.

**UNITIZED CONSTRUCTION**

Precision double-rolled unitized construction provides durable, leak-proof service and long life.



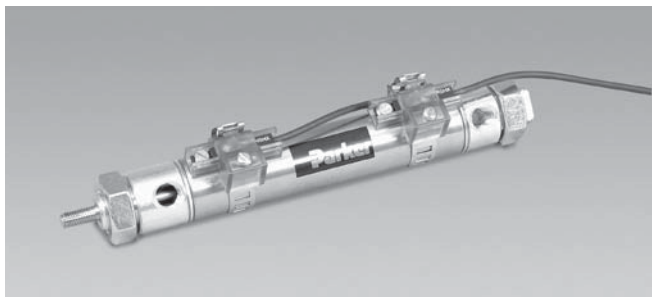
**HEADS AND CAPS**

Aluminum construction with precision machining provides a smooth break away. The tube-to-head connection is a strong double rolled construction.

**CYLINDER TUBE**

Type 304 stainless steel, polished to a micro-inch finish on the I.D. provides low friction and long life. A matte finish on the O.D. provides smudge resistance.

**TWELVE BORE SIZES** – 5/16" thru 3". SR Series cylinders are designed to be dimensionally interchangeable with other major stainless steel cylinders.



**SRM Series**

The SRM Series air cylinder can be ordered with reed or solid state sensors that are easily adjustable anywhere on the cylinder body, with no special mounting rail required. Nitrile-barium particle composite surrounds the entire piston diameter for non-contact sensing.

Sensors are compatible with Programmable Controllers; an LED indicator is also standard. A shielded cable is standard, and can be extended to 32 feet maximum by the user.



**SRD/SRDM Series**

SRD/SRDM Series cylinders are designed to withstand a wide range of operating environments to tolerate moisture and many types of lubricants and solvents. The cylinders have a acetal resin head and cap, an anodized aluminum piston, stainless steel cylinder tube and stainless steel piston rod. Stainless steel accessories are available.

Pneumatic Cylinders	Round Body
	SR/SRM/SRD/SRDM Series
SRG/SRGM Series	SRX Series
P1A Series	P Series



For inventory, lead times, and kit lookup, visit [www.pdnplu.com](http://www.pdnplu.com)

## Features

- 304 stainless steel cylinder body, non repairable construction
- Aluminum heads and caps, acetal resin heads and caps are optional
- 12 bore sizes — 5/16" through 3" (see dimensional tables for SRM and SRD/SRDM exclusions).
- Stainless steel piston rods are standard up to 1.50" bore
- 28 standard mounting styles (not all available on SRM and SRD/SRDM – see table on following page)
- Single and double acting
- Adjustable cushions optional on both ends




### Operating information

Operating pressure: 250 PSIG (17 bar) for SR and SRM  
100 PSIG (7 bar) for SRD/SRDM

Temperature range: -10°F to 165°F (-23°C to 74°C) for SR  
14°F to 140°F (-10°C to 60°C) for SRM  
32°F to 160°F (0°C to 71°C) for SRD/SRDM

Filtration requirements: 40 micron, dry filtered air

### Ordering information

<b>1.06</b>	<b>C</b>	<b>D</b>	<b>SR</b>	<b>B</b>	<b>V</b>	<b>C</b>	<b>2.00</b>																																																						
<table border="1"> <tr><th colspan="2">Bore Size<sup>1,6</sup></th></tr> <tr><td>.31</td><td>5/16"</td></tr> <tr><td>.44</td><td>7/16"</td></tr> <tr><td>.56</td><td>9/16"</td></tr> <tr><td>.75</td><td>3/4"</td></tr> <tr><td>.88</td><td>7/8"</td></tr> <tr><td>1.06</td><td>1-1/16"</td></tr> <tr><td>1.25</td><td>1-1/4"</td></tr> <tr><td>1.50</td><td>1-1/2"</td></tr> <tr><td>1.75</td><td>1-3/4"</td></tr> <tr><td>2.00</td><td>2"</td></tr> <tr><td>2.50</td><td>2-1/2"</td></tr> <tr><td>3.00</td><td>3"</td></tr> </table>	Bore Size <sup>1,6</sup>		.31	5/16"	.44	7/16"	.56	9/16"	.75	3/4"	.88	7/8"	1.06	1-1/16"	1.25	1-1/4"	1.50	1-1/2"	1.75	1-3/4"	2.00	2"	2.50	2-1/2"	3.00	3"	<table border="1"> <tr><th colspan="2">Cushion Head<sup>2</sup></th></tr> <tr><td colspan="2">Use "C" only when cushion head is required.</td></tr> </table>	Cushion Head <sup>2</sup>		Use "C" only when cushion head is required.			<table border="1"> <tr><th colspan="2">Series</th></tr> <tr><td>SR</td><td>Standard cylinder</td></tr> <tr><td>SRM</td><td>With magnetic piston</td></tr> <tr><td>SRD</td><td>With acetal resin caps</td></tr> <tr><td>SRDM</td><td>With acetal resin caps and magnetic piston</td></tr> </table>	Series		SR	Standard cylinder	SRM	With magnetic piston	SRD	With acetal resin caps	SRDM	With acetal resin caps and magnetic piston	<table border="1"> <tr><th colspan="2">Piston</th></tr> <tr><td>Blank</td><td>No bumpers</td></tr> <tr><td>B</td><td>With bumpers<sup>3</sup></td></tr> </table>	Piston		Blank	No bumpers	B	With bumpers <sup>3</sup>		<table border="1"> <tr><th colspan="2">Cushion Cap<sup>2</sup></th></tr> <tr><td colspan="2">Use "C" only when cushion cap is required.</td></tr> </table>	Cushion Cap <sup>2</sup>		Use "C" only when cushion cap is required.		<table border="1"> <tr><th colspan="2">Stroke</th></tr> <tr><td colspan="2">Specify in inches.</td></tr> </table>	Stroke		Specify in inches.	
Bore Size <sup>1,6</sup>																																																													
.31	5/16"																																																												
.44	7/16"																																																												
.56	9/16"																																																												
.75	3/4"																																																												
.88	7/8"																																																												
1.06	1-1/16"																																																												
1.25	1-1/4"																																																												
1.50	1-1/2"																																																												
1.75	1-3/4"																																																												
2.00	2"																																																												
2.50	2-1/2"																																																												
3.00	3"																																																												
Cushion Head <sup>2</sup>																																																													
Use "C" only when cushion head is required.																																																													
Series																																																													
SR	Standard cylinder																																																												
SRM	With magnetic piston																																																												
SRD	With acetal resin caps																																																												
SRDM	With acetal resin caps and magnetic piston																																																												
Piston																																																													
Blank	No bumpers																																																												
B	With bumpers <sup>3</sup>																																																												
Cushion Cap <sup>2</sup>																																																													
Use "C" only when cushion cap is required.																																																													
Stroke																																																													
Specify in inches.																																																													
<table border="1"> <tr><th colspan="2">Double Rod</th></tr> <tr><td colspan="2">Use "K" only when double rod is required. Available on DX and DXH mounting only.</td></tr> </table>	Double Rod		Use "K" only when double rod is required. Available on DX and DXH mounting only.							<table border="1"> <tr><th colspan="2">Non-Standard Piston Rod</th></tr> <tr><td colspan="2">Use "3" only when special piston rod end is required. Specify CC, LE and A Dimensions (See page C7.)</td></tr> </table>	Non-Standard Piston Rod		Use "3" only when special piston rod end is required. Specify CC, LE and A Dimensions (See page C7.)																																																
Double Rod																																																													
Use "K" only when double rod is required. Available on DX and DXH mounting only.																																																													
Non-Standard Piston Rod																																																													
Use "3" only when special piston rod end is required. Specify CC, LE and A Dimensions (See page C7.)																																																													
<table border="1"> <tr><th colspan="2">Mounting<sup>1,5</sup></th></tr> <tr><td colspan="2">N, NR, NRP, P, R, RP, D, DP, DXP, DX, DXH, A, RA, AP, AR, BRN, BRR, BFD, BRD, BFN, BFR, TRN, TRR, TFD, TRD, TFN or TFR.</td></tr> </table>	Mounting <sup>1,5</sup>		N, NR, NRP, P, R, RP, D, DP, DXP, DX, DXH, A, RA, AP, AR, BRN, BRR, BFD, BRD, BFN, BFR, TRN, TRR, TFD, TRD, TFN or TFR.						<table border="1"> <tr><th colspan="2">Non-Standard Rod</th></tr> <tr><td colspan="2">Specify Y for stainless steel piston rod. Stainless steel is standard on all bore sizes up to and including 1.50" Bore and all SRD/ SRDM versions.</td></tr> </table>	Non-Standard Rod		Specify Y for stainless steel piston rod. Stainless steel is standard on all bore sizes up to and including 1.50" Bore and all SRD/ SRDM versions.																																																	
Mounting <sup>1,5</sup>																																																													
N, NR, NRP, P, R, RP, D, DP, DXP, DX, DXH, A, RA, AP, AR, BRN, BRR, BFD, BRD, BFN, BFR, TRN, TRR, TFD, TRD, TFN or TFR.																																																													
Non-Standard Rod																																																													
Specify Y for stainless steel piston rod. Stainless steel is standard on all bore sizes up to and including 1.50" Bore and all SRD/ SRDM versions.																																																													
					<table border="1"> <tr><th colspan="2">Special</th></tr> <tr><td colspan="2">Use "S" only if special modifications are required, except piston rod end. (See page C7.)</td></tr> </table>	Special		Use "S" only if special modifications are required, except piston rod end. (See page C7.)																																																					
Special																																																													
Use "S" only if special modifications are required, except piston rod end. (See page C7.)																																																													
				<table border="1"> <tr><th colspan="2">Seals</th></tr> <tr><td>Blank</td><td>Standard seals</td></tr> <tr><td>V</td><td>Fluorocarbon seals<sup>4</sup></td></tr> <tr><td>W</td><td>Rod wiper</td></tr> </table>	Seals		Blank	Standard seals	V	Fluorocarbon seals <sup>4</sup>	W	Rod wiper																																																	
Seals																																																													
Blank	Standard seals																																																												
V	Fluorocarbon seals <sup>4</sup>																																																												
W	Rod wiper																																																												
						<table border="1"> <tr><th colspan="2">Sensors</th></tr> <tr><td colspan="2">See section L for sensors.</td></tr> </table> 	Sensors		See section L for sensors.																																																				
Sensors																																																													
See section L for sensors.																																																													

<sup>1</sup> Bore sizes and mounting styles are limited by series. See table on next page for availability.  
<sup>2</sup> Cushions not available on SRD/SRDM series, only available on D, DP, DXP mounts, reference page C31.  
<sup>3</sup> Bumpers may increase cylinder length. Please reference page C30 for adders.  
<sup>4</sup> Fluorocarbon seals not available on SRM or SRDM series.  
<sup>5</sup> TRD mount not available with cushions.  
<sup>6</sup> Magnet not available on bore sizes .31, .44, .88 and 3.00.

For ordering purposes, when special options or common modifications are requested, the factory will assign a sequential part number in place of the model number.



For inventory, lead time, and kit lookup, visit [www.pdnplu.com](http://www.pdnplu.com)



**Available Mounting Styles**

Mount Style	Description	Bore Size (Reference Notes 1 & 2 for availability)											Max. Stroke (in.)	
		5/16" (1,2)	7/16" (1,2)	9/16"	3/4"	7/8" (1,2)	1-1/16"	1-1/4" (2)	1-1/2" (2)	1-3/4" (2)	2" (2)	2-1/2" (2)		3" (1,2)
N <sup>(2)</sup>	Nose mount, spring return	●	●	●	●	●	●	●	●	●	▲	—	—	6" <sup>(3)</sup>
NR <sup>(2)</sup>	Nose mount, spring return, hex rod (non-rotating)	—	●	●	●	●	●	●	●	●	—	—	—	6"
NRP <sup>(2)</sup>	Pivot and nose mount, spring return, hex rod (non-rotating)	—	●	●	●	●	●	●	●	●	—	—	—	6"
P <sup>(2)</sup>	Pivot mount, spring return	●	●	●	●	●	●	●	●	●	▲	—	—	6"
R <sup>(2)</sup>	Nose mount, spring extended	●	●	●	●	●	●	●	●	●	▲	—	—	6"
RP <sup>(2)</sup>	Pivot and nose mount, spring extend	●	●	●	●	●	●	●	—	▲	—	—	—	6"
D	Nose mount, double acting	●	●	●	●	●	●	●	●	●	●	●	●	12"
DP <sup>(2)</sup>	Pivot and nose mount, double acting, pivot pin	—	●	—	●	—	●	—	●	—	—	—	—	12"
DXP	Pivot and nose mount, double acting, no pivot pin	●	●	●	●	●	●	●	●	●	●	●	●	See Note 4
DX	Threaded both ends, double acting	—	See DXP	See DXP	See DXP	See DXP	See DXP	See DXP	●	—	See DXP	—	—	32"
KDX	Threaded both ends, double acting, double rod	—	●	●	●	●	●	●	●	●	●	●	●	See Note 5
KDXH <sup>(2)</sup>	Threaded both ends, double rod, hollow rod	—	—	—	—	—	●	●	●	●	●	—	—	12"
A <sup>(1,2)</sup>	Nose mount, spring return, head adjustable stroke	—	—	—	●	—	●	—	●	—	—	—	—	6"
RA <sup>(1,2)</sup>	Nose mount, spring extend, cap adjustable stroke	—	—	—	●	—	●	—	●	—	—	—	—	6"
AP <sup>(1,2)</sup>	Pivot mount, spring return, head adjustable stroke	—	—	—	●	—	●	—	●	—	—	—	—	6"
AR <sup>(1,2)</sup>	Air reservoirs	—	—	—	●	—	●	—	●	—	●	—	—	12"
BRN <sup>(2)</sup>	Rear block mount, single acting,	—	●	—	●	—	●	—	●	—	—	—	—	6"
BRR <sup>(2)</sup>	Rear block mount, single acting, spring return	—	—	—	●	—	●	—	●	—	—	—	—	6"
BFD <sup>(2)</sup>	Front block mount, double acting	●	●	—	●	—	●	—	●	—	—	—	—	12"
BRD <sup>(2)</sup>	Rear block mount, double acting	—	●	—	●	—	●	—	●	—	—	—	—	12"
BFN <sup>(2)</sup>	Front block mount, single acting spring return	—	●	—	●	—	●	—	●	—	—	—	—	6"
BFR <sup>(2)</sup>	Front block mount, single acting spring extend	—	—	—	●	—	●	—	●	—	—	—	—	6"
TRN <sup>(2)</sup>	Rear trunnion mount, single acting, spring return	—	●	—	●	—	●	—	●	—	—	—	—	6"
TRR <sup>(2)</sup>	Rear trunnion mount, single acting spring extend	—	—	—	●	—	●	—	●	—	—	—	—	6"
TFD <sup>(2)</sup>	Front trunnion mount, double acting	—	●	—	●	—	●	—	●	—	—	—	—	12"
TRD <sup>(2)</sup>	Rear trunnion mount, double acting	—	●	—	●	—	●	—	●	—	—	—	—	12"
TFN <sup>(2)</sup>	Front trunnion mount, single acting spring return	—	●	—	●	—	●	—	●	—	—	—	—	6"
TFR <sup>(2)</sup>	Front trunnion mount, single acting spring extend	—	—	—	●	—	●	—	●	—	—	—	—	6"

- ▲ Recommended maximum stroke is 4" in models N, P, R & RP.
- 1 Not available on SRM (magnetic piston) cylinders.
- 2 Not available on SRD/DM (acetel resin caps) cylinders.
- 3 Recommended maximum stroke is 4" for 5/16" bore models.
- 4 Max stroke 12" for bore sizes under 3/4"; 32" for bore sizes 3/4" and up.
- 5 Max stroke 6" for bore sizes under 3/4"; 12" for bore sizes 3/4" and up.

**Round Body Pneumatic Cylinders**  
 SR/SRM/SRD/SRDM Series  
 SRG/SRGM Series  
 SRX Series  
 P1A Series  
 P Series



For inventory, lead times, and kit lookup, visit [www.pdnplu.com](http://www.pdnplu.com)

**Specifications**

- 304 stainless steel cylinder body.
- Aluminum heads and caps.
- Stainless steel piston rods are standard up to 1.50" bore.
- Nominal pressure rating: 250 psi for SR and SRM  
100 psi for SRD/SRDM
- Standard temperature: -10°F to 165°F (SR)  
14°F to 140°F (SRM)  
32°F to 160°F (SRD/SRDM)  
-10°F to 1250°F (Fluorocarbon seals)

In line with our policy of continuing product improvement, the specifications in this catalog are subject to change without notice.

- Twelve bore sizes — 5/16" through 3" (see table for SRM and SRD/DM exclusions).
- 28 standard mounting styles (not all available on SRM and SRD/SRDM – see table on previous page).
- Single and double acting
- Bumpers
- Adjustable cushions
- Rod wipers

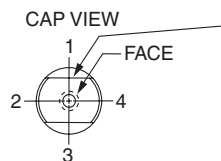
For additional mounting styles please consult factory.

**Port Locations**

Mounting Style	Standard Head Port Location	Standard Cap Port Location	Standard Vent Location
AR	Face	Face	None
BFR	2	None	2
BFN	None	Face	2
BRD	2	2	None
BFD	2	Face	None
BRR	2	None	2
BRN	None	2	2
TFR	1	None	1
TFN	None	Face	1
TRD	1	1	None
TFD	1	Face	None
TRR	1	None	1
TRN	None	1	1
AP	None	2	2
RA	2	None	2
A	None	Face	2
KDXH	2	2	None
KDX	2	2	None
DX	2	2	None
DXP	2	2	None
DP	2	2	None
D	2	Face	None
RP	2	None	2
R	2	None	2
P	None	2	2
NRP	None	2	2
NR	None	Face	2
N	None	Face	2

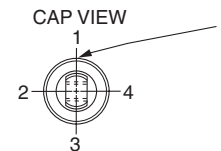
**End View of Mountings for Port Location**

**Mounting Styles N, NR, D, R, AR**



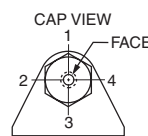
Standard location for cushion adjustment needle when cushions are specified on D mounts.

**Mounting Styles P, RP, DXP, NRP, DP, AP**

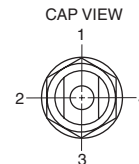


Standard location for cushion adjustment needle when cushions are specified on DXP mounts.

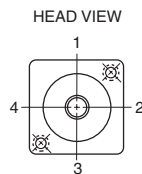
**Mounting Style A**



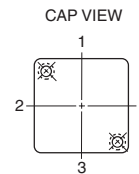
**Mounting Style RA**



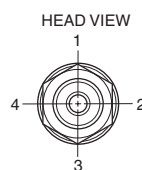
**Mounting Styles BFD, BFN, BFR**



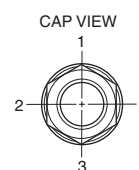
**Mounting Styles BRN, BRR, BRD**



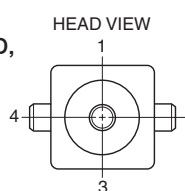
**Mounting Styles KDXH, KDX**



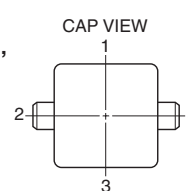
**Mounting Style DX**



**Mounting Styles TFD, TFN, TFR**



**Mounting Styles TRN, TRR, TRD**



Cylinders will have ports at these locations unless otherwise specified.

**Round Body Pneumatic Cylinders**  
**SR/SRM/SRD/SRDM Series**  
**SRG/SRGM Series**  
**SRX Series**  
**P1A Series**  
**P Series**



For inventory, lead time, and kit lookup, visit [www.pdnplu.com](http://www.pdnplu.com)

Technical Data

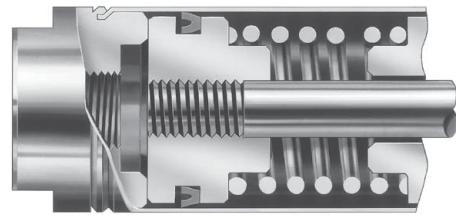
Port Size — Rod Diameter, Spring Force Data

Bore size	Port size	Rod diameter (or Hex)	Force factor		Spring return (lbs)		Spring extend (lbs)	
			Push	Pull	Normal	Extended	Normal	Retracted
.31 (5/16")	#10-32	1/8"	0.08	0.06	0.5	1	0.5	1
.44 (7/16")	#10-32	3/16"	0.15	0.12	1	2	1	2
.56 (9/16")	#10-32	3/16"	0.25	0.22	2	4	2	4
.75 (3/4")	1/8 NPTF	1/4"	0.44	0.39	3	6	3	6
.88 (7/8")	1/8 NPTF	1/4"	0.60	0.55	3	6	3	6
1.06 (1-1/16")	1/8 NPTF	5/16**	0.89	0.81	3†	6†	7.5	15
1.25 (1-1/4")	1/8 NPTF	7/16"	1.23	1.08	7.5	15	7.5	15
1.50 (1-1/2")	1/8 NPTF	7/16"	1.77	1.62	6†	12†	9	18
1.75 (1-3/4")	1/4 NPTF	1/2"	2.40	2.21	11	24	11	24
2.00 (2")	1/4 NPTF	5/8"	3.14	2.84	15	30	15	30
2.50 (2-1/2")	1/4 NPTF	5/8"	4.91	4.60	N/A	N/A	N/A	N/A
3.00 (3")	3/8 NPTF	3/4"	7.07	6.63	N/A	N/A	N/A	N/A

\* Non-rotating version uses 3/8" hex.

† Block mount and trunnion mount spring return lbs. equals spring extend lbs.

**Springs** — shot peened music wire for high cycle life. Spring spacers are provided for every one inch of stroke (1/2" for 5/16" and 7/16" bores) to insure uniform spring rate and prevent spring failure.



Option Availability

Option	Bumpers	Fluorocarbon seals	Rod wipers	Cushions	Acetal resin end caps
Bumpers	—	◆	◆	X	◆
Fluorocarbon seals	—	—	X	S	◆
Rod wiper	—	—	—	◆	◆
Cushions	—	—	—	—	X

◆ = Available Options  
S = Available as Special  
X = Not Available

Round Body Pneumatic Cylinders  
 SR/SRM/SRD/SRDM Series  
 SRG/SRGM Series  
 SRX Series  
 P1A Series  
 P Series

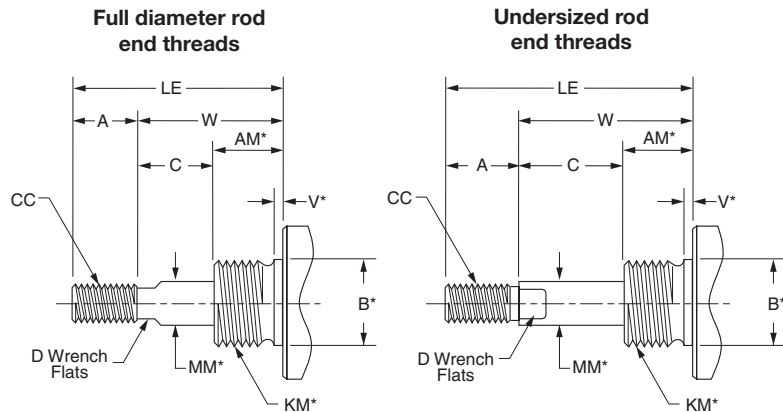


For inventory, lead times, and kit lookup, visit [www.pdnplu.com](http://www.pdnplu.com)

Non-Standard Rods, Mounting Style – N

Non-Standard Rods

For non-standard rod dimensions, or undersized rod end threads, put a “3” in model number and describe the rod using the letters shown in the drawing. Specify CC, LE and A dimensions. LE is measured in retracted position.

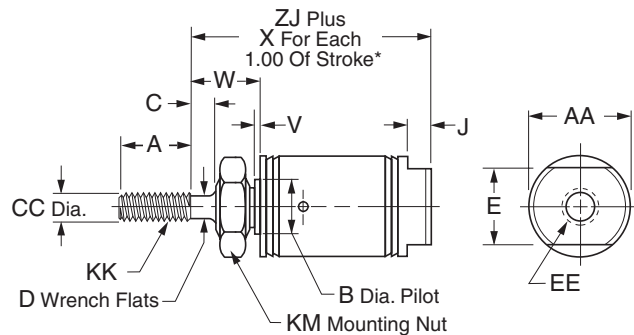


\* Requires an S designation in model number.

Style N

Nose mount, spring return

Bore size	SR	SRM	Std. strokes (in)	Max. stroke (in)	SS rod std
5/16"	•		1/2, 1, 1-1/2, 2, 2-1/2, 3, 4	4	✓
7/16"	•		1/2, 1, 1-1/2, 2, 2-1/2, 3, 4	6	✓
9/16"	•	•	1/2, 1, 1-1/2, 2, 3, 4	6	✓
3/4"	•	•	1/2, 1, 1-1/2, 2, 3, 4	6	✓
7/8"	•		1/2, 1, 1-1/2, 2, 3, 4	6	✓
1-1/16"	•	•	1/2, 1, 1-1/2, 2, 3, 4	6	✓
1-1/4"	•	•	1/2, 1, 2, 3, 4	6	✓
1-1/2"	•	•	1/2, 1, 2, 3, 4	6	✓
1-3/4"	•	•	1/2, 1, 1-1/2, 2, 2-1/2, 3, 4	6	✓
2"	•	•	-	4	



Bore size															SR	SRM
	A	AA	B	C	CC	D	E	EE	J	KK	KM	V	W	X	ZJ	ZJ
5/16"	0.38	0.36	-	-	0.125	-	0.36	#10-32	-	#5-40 UNC	1/4-28	0	0.25	0.75**	1.12	-
7/16"	0.50	0.50	0.374	-	0.188	-	0.38	#10-32	0.19	#10-32 UNF	3/8-24	0.05	0.31	0.94**	1.31	-
9/16"	0.50	0.62	0.437	-	0.188	-	0.50	#10-32	0.19	#10-32 UNF	7/16-20	0.06	0.38	1.62	1.53	1.76
3/4"	0.50	0.81	0.499	-	0.250	-	0.62	1/8 NPTF	0.19	1/4-28 UNF	1/2-20	0.09	0.44	1.69	1.50	1.75
7/8"	0.50	0.93	0.624	-	0.250	-	0.62	1/8 NPTF	0.19	1/4-28 UNF	5/8-18	0.09	0.50	1.56	1.84	-
1-1/16"	0.50	1.12	0.624	0.12	0.312	0.25	0.88	1/8 NPTF	0.19	5/16-24 UNF	5/8-18	0.09	0.69	1.56	2.06	2.31
1-1/4"	0.75	1.34	0.749	0.25	0.437	0.38	0.88	1/8 NPTF	0.25	7/16-20 UNF	3/4-16	0.09	0.88	1.81	2.66	2.78
1-1/2"	0.75	1.56	0.749	0.25	0.437	0.38	0.88	1/8 NPTF	0.25	7/16-20 UNF	3/4-16	0.09	0.88	1.69	2.44	2.69
1-3/4"	0.88	1.84	1.031	0.38	0.500	7/16	1.25	1/4 NPTF	0.25	1/2-20 UNF	1-14	0.09	0.75	2.0	2.97	3.09
2"	0.88	2.08	1.374	0.38	0.625	0.50	1.25	1/4 NPTF	0.31	1/2-20 UNF	1-1/4 †	0.12	1.19	-	▲	▲

▲ SR: 5.41" for 1" stroke, 7.41" for 2" stroke, 8.66" for 3" stroke, 11.59" for 4" stroke.  
SRM: 5.66" for 1" stroke, 7.66" for 2" stroke, 8.91" for 3" stroke, 11.84" for 4" stroke.

\* To determine lengths for half inch stroke increments, determine length for next highest whole number stroke and subtract a half inch.

\*\* For each 0.50" of stroke

† No mounting nut



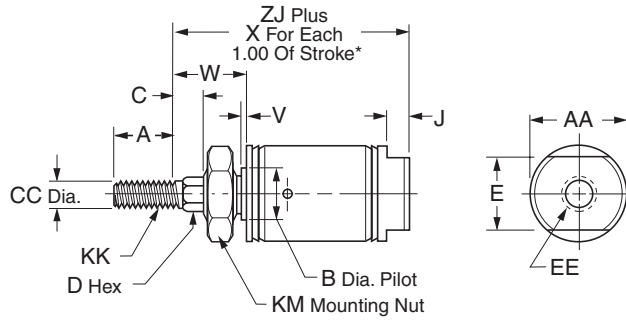
For inventory, lead time, and kit lookup, visit [www.pdnplu.com](http://www.pdnplu.com)

Round Body Pneumatic Cylinders  
 SR/SRM/SRD/SRDM Series  
 SRG/SRGM Series  
 SRX Series  
 P1A Series  
 P Series

Mounting Style – NR

Style NR

Nose mount, spring return, hex rod



Bore size	SR	SRM	Std. stroke (in)	Max. stroke (in)	SS rod std
7/16"	•		1/2, 1, 1-1/2, 2, 3, 4	6	✓
9/16"	•	•	1/2, 1, 1-1/2, 2, 3, 4	6	✓
3/4"	•	•	1/2, 1, 1-1/2, 2, 3, 4	6	✓
7/8"	•		1/2, 1, 1-1/2, 2, 3, 4	6	✓
1-1/16"	•	•	1/2, 1, 1-1/2, 2, 3, 4	6	✓
1-1/4"	•	•	1, 2, 3, 4	6	✓
1-1/2"	•	•	1/2, 1, 2, 3, 4	6	✓
1-3/4"	•	•	1/2, 1, 1-1/2, 2, 2-1/2, 3, 4	6	

Bore size	A	AA	B	C	CC	D	E	EE	J	KK	KM	V	W	X	SR ZJ	SRM ZJ
7/16"	0.50	-	0.374	0.25	0.188	3/16	-	#10-32	0.19	#10-32 UNF	3/8-24	0.05	0.56	0.94	1.56	-
9/16"	0.50	-	0.437	0.25	0.188	3/16	-	#10-32	0.19	#10-32 UNF	7/16-20	0.06	0.62	1.62	1.78	2.03
3/4"	0.50	-	0.499	0.25	0.250	1/4	-	1/8 NPTF	0.19	1/4-28 UNF	1/2-20	0.09	0.69	1.69	1.75	2.00
7/8"	0.50	-	0.624	0.25	0.250	1/4	-	1/8 NPTF	0.19	1/4-28 UNF	5/8-18	0.09	0.75	1.56	2.09	-
1-1/16"	0.50	1.12	0.624	0.25	0.312	3/8	0.88	1/8 NPTF	0.19	5/16-24 UNF	5/8-18	0.09	0.75	1.56	2.19	2.44
1-1/4"	0.88	1.34	0.749	0.25	0.437	7/16	0.88	1/8 NPTF	0.25	7/16-20 UNF	3/4-16	0.09	0.88	1.81	2.66	2.78
1-1/2"	0.88	1.56	0.749	0.38	0.437	7/16	0.88	1/8 NPTF	0.25	7/16-20 UNF	3/4-16	0.09	1.00	1.69	2.56	2.81
1-3/4"	0.88	1.84	1.031	0.38	0.500	1/2	1.25	1/4 NPTF	0.25	1/2-20 UNF	1-14	0.09	1.12	2.0	3.03	3.15

\* To determine lengths for half inch stroke increments, determine length for next highest whole number stroke and subtract one half inch.

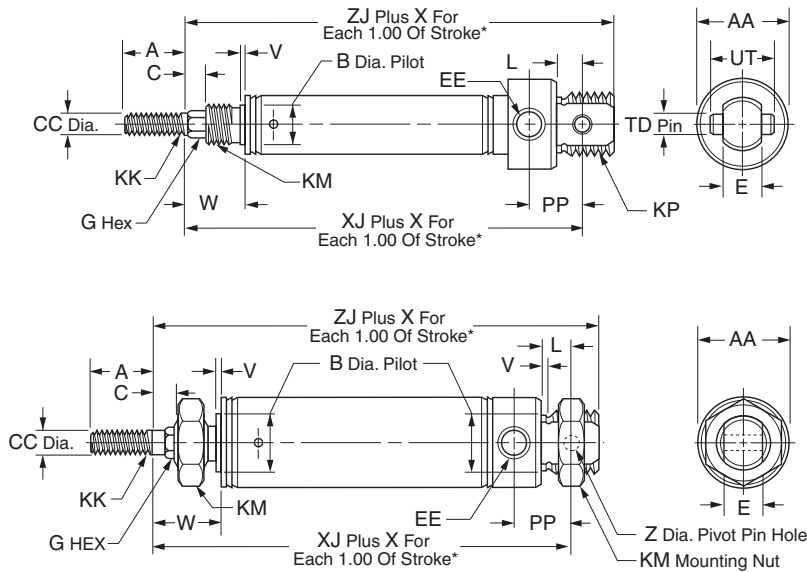


For inventory, lead times, and kit lookup, visit [www.pdnplu.com](http://www.pdnplu.com)



**Style NRP**

Pivot & nose mount, spring return, hex rod



**Bore sizes**

7/16" *
3/4"

\* No mounting nuts

**Bore sizes**

9/16" *
7/8" *
1-1/16" *
1-1/4"
1-1/2" *
1-3/4"

\* No mounting nuts

Bore size	SR	SRM	Std. stroke (in)	Max. stroke (in)	SS rod std	A	AA	B	C	CC	E	EE
7/16"	•		1/2, 1, 1-1/2, 2, 3, 4	6	✓	0.50	0.74	0.374	0.25	0.188	0.31	#10-32
9/16"	•	•	1/2, 1, 1-1/2, 2, 3, 4	6	✓	0.50	0.62	0.437	0.25	0.188	0.31	#10-32
3/4"	•	•	1, 2, 3, 4	6	✓	0.50	0.86	0.499	0.25	0.250	0.38	1/8 NPTF
7/8"	•		1, 2, 3, 4	6	✓	0.50	0.93	0.624	0.25	0.250	0.38	1/8 NPTF
1-1/16"	•	•	1, 2, 3, 4	6	✓	0.50	1.12	0.624	0.25	0.312	0.38	1/8 NPTF
1-1/4"	•	•	1, 2, 3, 4	6	✓	0.88	1.34	0.749	0.25	0.437	0.50	1/8 NPTF
1-1/2"	•	•	1, 2, 3, 4	6	✓	0.88	1.56	0.749	0.38	0.437	0.62	1/8 NPTF
1-3/4"	•	•	1/2, 1, 1-1/2, 2, 2-1/2, 3, 4	6		0.88	1.84	1.031	0.38	0.500	0.62	1/4 NPTF

Bore size	SR		SRM		L	PP	TD	UT	V	W	X	SR			SRM	
	G HEX	KK	KM	KP								Z	ZJ	ZJ		
7/16"	3/16	#10-32 UNF	3/8-24	7/16-20 UNF	0.25	0.44	0.156	0.50	0.05	0.56	0.94	2.00	-	-	2.25	-
9/16"	3/16	#10-32 UNF	7/16-20	7/16-20 UNF	0.25	0.38	-	-	0.06	0.62	1.62	2.06	2.31	0.157	2.25	2.50
3/4"	1/4	1/4-28 UNF	1/2-20	5/8-18 UNF	0.34	0.62	0.250	0.75	0.09	0.69	1.69	2.53	2.78	-	2.81	3.06
7/8"	1/4	1/4-28 UNF	5/8-18	5/8-18 UNF	0.34	0.62	0.250	0.75	0.09	0.75	1.56	2.72	-	-	3.00	-
1-1/16"	3/8	5/16-24 UNF	5/8-18	5/8-18 UNF	0.34	0.62	0.250	0.75	0.09	0.75	1.56	2.78	3.03	-	3.06	3.31
1-1/4"	7/16	7/16-20 UNF	3/4-16	-	0.41	0.78	0.251	-	0.09	0.88	1.81	3.38	3.50	0.251	3.78	3.91
1-1/2"	7/16	7/16-20 UNF	3/4-16	-	0.50	0.81	0.375	1.00	0.09	1.00	1.69	3.25	3.50	-	3.62	3.87
1-3/4"	1/2	1/2-20 UNF	1-14	-	0.50	1.12	0.376	0.62	0.09	1.12	2.0	4.09	4.21	0.376	4.59	4.71

\* To determine lengths for half inch stroke increments, determine length for next highest whole number stroke and subtract one half inch.

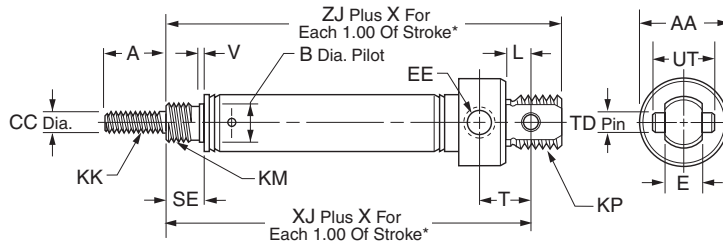


For inventory, lead time, and kit lookup, visit [www.pdnplu.com](http://www.pdnplu.com)

**Round Body Pneumatic Cylinders**  
**SR/SRM/SRD/SRDM Series**  
**SRG/SRGM Series**  
**SRX Series**  
**P1A Series**  
**P Series**

**Style P**

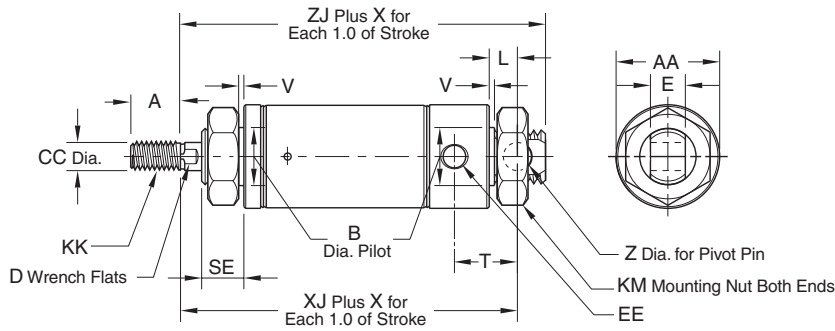
Pivot mount, spring return



**Bore sizes**

- 5/16" \*
- 7/16"
- 3/4"

\* No mounting nuts



**Bore sizes**

- 9/16" \*
- 7/8" \*
- 1-1/16" \*
- 1-1/4"
- 1-1/2" \*
- 1-3/4"
- 2" \*

\* No mounting nuts

Bore size	SR	SRM	Std. stroke (in)	Max. stroke (in)	SS rod std	A	AA	B	CC	D	E	EE
5/16"	•		1/2, 1, 1-1/2, 2, 3, 4	4	✓	0.38	0.39	-	0.125	-	0.25	#10-32
7/16"	•		1/2, 1, 1-1/2, 2, 3, 4	6	✓	0.50	0.74	0.374	0.188	-	0.31	#10-32
9/16"	•	•	1/2, 1, 1-1/2, 2, 3, 4	6	✓	0.50	0.62	0.437	0.188	-	0.31	#10-32
3/4"	•	•	1/2, 1, 1-1/2, 2, 3, 4	6	✓	0.50	0.86	0.499	0.250	-	0.38	1/8 NPTF
7/8"	•		1/2, 1, 1-1/2, 2, 3, 4	6	✓	0.50	0.93	0.624	0.250	-	0.38	1/8 NPTF
1-1/16"	•	•	1/2, 1, 1-1/2, 2, 3, 4	6	✓	0.50	1.12	0.624	0.312	0.25	0.38	1/8 NPTF
1-1/4"	•	•	1, 2, 3, 4	6	✓	0.75	1.34	0.749	0.437	0.38	0.50	1/8 NPTF
1-1/2"	•	•	1, 2, 3, 4	6	✓	0.75	1.56	0.749	0.437	0.38	0.62	1/8 NPTF
1-3/4"	•	•	1/2, 1, 1-1/2, 2, 2-1/2, 3, 4	6		0.88	1.84	1.031	0.500	7/16	0.62	1/4 NPTF
2"	•	•	-	4		0.88	2.08	1.374	0.625	0.50	0.75	1/4 NPTF

Bore size	KK	KM	KP	L	SE	T	TD	UT	V	X	SR XJ	SRM XJ	Z	SR ZJ	SRM ZJ
5/16"	#5-40 UNC	3/8-24	-	0.34	0.25	0.34	-	-	-	0.75	1.52	-	0.125	1.68	-
7/16"	#10-32 UNF	3/8-24	7/16-20 UNF	0.25	0.31	0.44	0.156	0.50	0.05	0.94	1.75	-	-	2.00	-
9/16"	#10-32 UNF	7/16-20	7/16-20 UNF	0.25	0.38	0.38	-	-	0.06	1.62	1.81	2.06	0.157	2.00	2.25
3/4"	1/4-28 UNF	1/2-20	5/8-18 UNF	0.34	0.44	0.62	0.250	0.75	0.09	1.69	2.28	2.53	-	2.56	2.81
7/8"	1/4-28 UNF	5/8-18	5/8-18 UNF	0.34	0.50	0.62	0.250	0.75	0.09	1.56	2.47	-	-	2.75	-
1-1/16"	5/16-24 UNF	5/8-18	5/8-18 UNF	0.34	0.50	0.62	0.250	0.75	0.09	1.56	2.66	2.91	-	2.94	3.19
1-1/4"	7/16-20 UNF	3/4-16	-	0.41	0.63	0.78	-	-	0.09	1.81	3.38	3.91	0.251	3.78	3.50
1-1/2"	7/16-20 UNF	3/4-16	-	0.50	0.63	0.81	0.375	1.00	0.09	1.81	3.12	3.37	-	3.50	3.75
1-3/4"	1/2-20 UNF	1-14	-	0.50	0.75	1.12	-	-	0.09	2.0	4.03	4.15	0.376	4.53	4.65
2"	1/2-20 UNF	1-1/4-12	-	0.56	0.81	1.03	-	-	0.12	-	■	*	-	▲	◆

- 6.34" for 1" stroke, 8.34" for 2" stroke, 9.59" for 3" stroke, 12.53" for 4" stroke\*
- ▲ 6.78" for 1" stroke, 8.78" for 2" stroke, 10.03" for 3" stroke, 12.97" for 4" stroke\*
- ◆ 6.59" for 1" stroke, 8.59" for 2" stroke, 9.84" for 3" stroke, 12.78" for 4" stroke\*
- \* 7.03" for 1" stroke, 9.03" for 2" stroke, 10.28" for 3" stroke, 13.22" for 4" stroke\*

\* To determine lengths for half inch stroke increments, determine length for next highest whole number stroke and subtract a half inch.



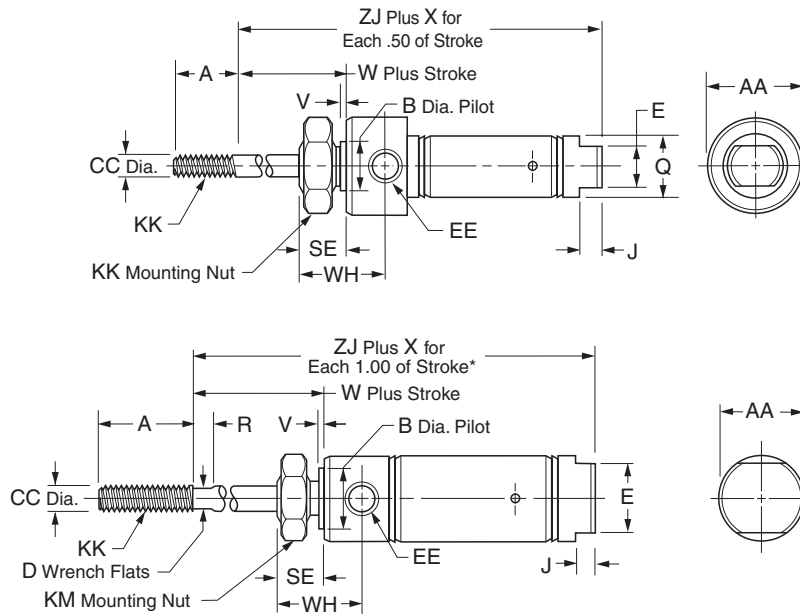
For inventory, lead times, and kit lookup, visit [www.pdnplu.com](http://www.pdnplu.com)

C10

Mounting Style – R

Style R

Nose mount, spring extended



Bore sizes
5/16
7/16"
3/4"

Bore sizes
9/16"
7/8"
1-1/16"
1-1/4"
1-1/2"
1-3/4"
2" *

\* No mounting nuts

Bore size	SR	SRM	Std. stroke (in)	Max. stroke (in)	SS rod std	A	AA	B	CC	D	E
5/16"	•		1/2, 1, 1-1/2, 2, 2-1/2, 3	4	✓	0.38	0.50 SQ.	–	0.125	–	–
7/16"	•		1/2, 1, 1-1/2, 2, 3	6	✓	0.50	0.74	0.437	0.188	–	0.38
9/16"	•	•	1/2, 1, 1-1/2, 2, 3	6	✓	0.50	0.62	0.437	0.188	–	0.50
3/4"	•	•	1/2, 1, 2, 3, 4	6	✓	0.50	0.86	0.624	0.250	–	–
7/8"	•		1/2, 1, 2, 3, 4	6	✓	0.50	0.93	0.624	0.250	–	–
1-1/16"	•	•	1/2, 1, 1-1/2, 2, 3, 4	6	✓	0.50	1.12	0.624	0.312	0.25	–
1-1/4"	•	•	1, 2, 3, 4	6	✓	0.75	1.34	0.749	0.437	0.38	–
1-1/2"	•	•	1, 2, 3, 4	6	✓	1.25	1.56	0.749	0.437	0.38	0.88
1-3/4"	•	•	1/2, 1, 1-1/2, 2, 2-1/2, 3, 4	6		0.88	1.84	1.031	0.500	7/16	–
2"	•	•	–	4		0.88	2.08	1.374	0.625	0.50	–

Bore size	EE	J	KK	KM	Q	R	SE	V	W	WH	X	SR ZJ	SRM ZJ
5/16"	#10-32	–	#5-40 UNC	3/8-24	0.36	–	0.31	–	0.31	0.47	1.25	1.49	–
7/16"	#10-32	0.19	#10-32 UNF	7/16-20	0.50	–	0.38	0.05	0.38	0.72	1.44	1.94	–
9/16"	#10-32	0.19	#10-32 UNF	7/16-20	0.62	–	0.38	0.05	0.38	0.78	2.62	2.00	2.25
3/4"	1/8 NPTF	–	1/4-28 UNF	5/8-18	0.81	–	0.50	0.09	0.50	0.97	2.69**	2.31	2.56
7/8"	1/8 NPTF	–	1/4-28 UNF	5/8-18	–	–	0.50	0.09	0.50	0.97	2.56	2.31	–
1-1/16"	1/8 NPTF	–	5/16-24 UNF	5/8-18	–	0.12	0.50	0.09	0.62	1.06	2.81	2.62	2.87
1-1/4"	1/8 NPTF	–	7/16-20 UNF	3/4-16	–	0.25	0.62	0.09	0.88	1.38	2.81	3.47	3.60
1-1/2"	1/8 NPTF	0.25	7/16-20 UNF	3/4-16	–	0.25	0.62	0.09	0.88	1.25	3.00	3.19	3.44
1-3/4"	1/4 NPTF	–	1/2-20 UNF	1-14	–	–	0.75	0.09	1.06	1.63	3.0	4.03	4.15
2"	1/4 NPTF	–	1/2-20 UNF	1-1/4-12	–	0.38	0.81	0.12	1.19	1.47	–	▲	◆

▲ 7.11" for 1" stroke, 10.11" for 2" stroke, 12.34" for 3" stroke, 16.34" for 4" stroke.\*

◆ 7.36" for 1" stroke, 10.36" for 2" stroke, 12.59" for 3" stroke, 16.59" for 4" stroke\*

\* To determine lengths for half inch stroke increments, determine length for next highest whole number stroke and subtract one half inch.

\*\* For each 1.00" of stroke.

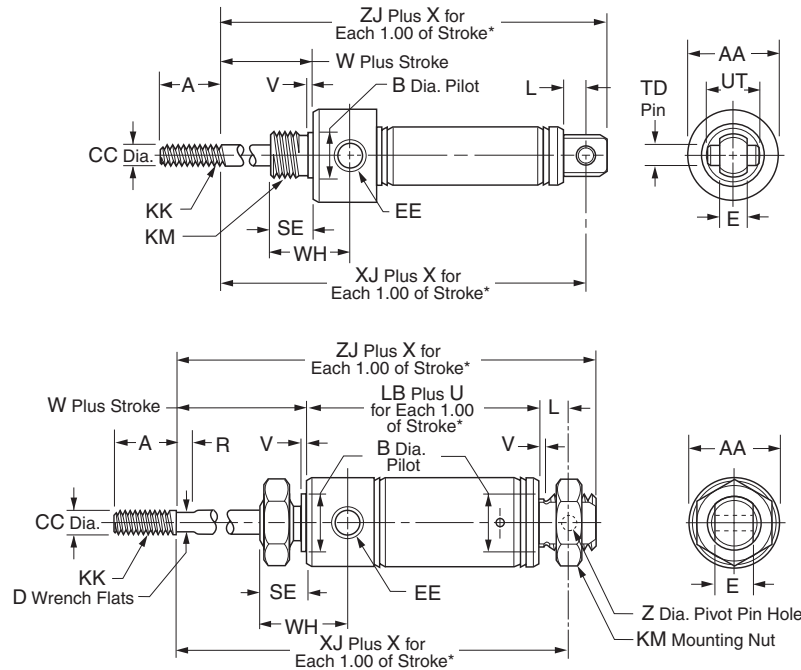


For inventory, lead time, and kit lookup, visit [www.pdnplu.com](http://www.pdnplu.com)

Round Body  
Pneumatic Cylinders  
SR/SRM/SRD/SRDM  
Series  
SRG/SRGM  
Series  
SRX  
Series  
P1A  
Series  
P  
Series

**Style RP**

Pivot and nose mount, spring extended



Bore sizes
5/16" *
7/16"
3/4"

\* No mounting nuts

Bore sizes
9/16" *
7/8" *
1-1/16" *
1-1/4"
1-1/2" *
1-3/4"
2" *

\* No mounting nuts

Bore size	SR	SRM	Std. stroke (in)	Max. stroke (in)	SS rod std	A	AA	B	CC	D	E	EE	KK
5/16"	•		1/2, 1, 1-1/2, 2, 2-1/2, 3	4	✓	0.38	0.50 SQ.	-	0.125	-	0.25	#10-32	#5-40 UNC
7/16"	•		1/2, 1, 1-1/2, 2, 3	6	✓	0.50	0.74	0.437	0.188	-	0.31	#10-32	#10-32 UNF
9/16"	•	•	1/2, 1, 1-1/2, 2, 3	6	✓	0.50	0.62	0.437	0.188	-	0.31	#10-32	#10-32 UNF
3/4"	•	•	1/2, 1, 2, 3, 4	6	✓	0.50	0.86	0.624	0.250	-	0.38	1/8 NPTF	1/4-28 UNF
7/8"	•		1/2, 1, 2, 3, 4	6	✓	0.50	0.93	0.624	0.250	-	0.38	1/8 NPTF	1/4-28 UNF
1-1/16"	•	•	1/2, 1, 1- 1/2, 2, 3, 4	6	✓	0.50	1.12	0.624	0.312	0.25	0.38	1/8 NPTF	5/16-24 UNF
1-1/4"	•	•	1, 2, 3, 4	6	✓	0.75	1.34	0.749	0.437	0.38	0.50	1/8 NPTF	7/16-20 UNF
1-1/2"	•	•	1, 2, 3, 4	6	✓	1.25	1.56	0.749	0.437	0.38	0.62	1/8 NPTF	7/16-20 UNF
2"	•	•	-	4		.88	2.08	1.374	0.625	0.50	0.75	1/4 NPTF	1/2-20 UNF

Bore size	KM	L	LB	R	SE	TD	U	UT	V	W	WH	X	SR XJ	SRM XJ	Z	SR ZJ	SRM ZJ
5/16"	3/8-24	0.19	-	-	0.31	-	-	-	-	0.31	0.47	1.25	1.88	-	-	2.04	-
7/16"	7/16-20	0.25	-	-	0.38	0.156	-	0.50	0.05	0.38	0.72	1.44	2.38	-	-	2.62	-
9/16"	7/16-20	0.25	-	-	0.38	-	-	-	0.06	0.38	0.78	2.62	2.28	2.53	0.157	2.47	2.72
3/4"	5/8-18	0.34	-	-	0.50	0.250	-	0.75	0.09	0.50	0.97	2.69	2.44	2.69	-	2.72	2.97
7/8"	5/8-18	0.34	-	-	0.50	0.250	-	0.75	0.09	0.50	0.97	2.56	2.63	-	-	2.91	-
1-1/16"	5/8-18	0.34	-	0.12	0.50	0.250	-	0.75	0.09	0.62	1.06	2.81	2.78	3.03	-	3.06	3.31
1-1/4"	3/4-16	0.41	2.47	0.25	0.62	-	1.81	-	0.09	0.88	1.38	2.81	3.78	3.91	0.251	4.16	4.28
1-1/2"	3/4-16	0.50	-	0.25	0.62	0.375	-	1.00	0.09	0.88	1.25	3.00	3.88	4.13	-	4.25	4.50
2"	1-1/4 -12	0.56	-	0.38	0.81	-	-	-	0.12	1.19	1.47	-	■	*	0.376	▲	◆

- 8.05" for 1" stroke, 11.05" for 2" stroke, 13.28" for 3" stroke, 17.28" for 4" stroke\*
- ▲ 8.50" for 1" stroke, 11.50" for 2" stroke, 13.72" for 3" stroke, 17.72" for 4" stroke\*
- \* 8.31" for 1" stroke, 11.31" for 2" stroke, 13.53" for 3" stroke, 17.53" for 4" stroke\*
- ◆ 8.75" for 1" stroke, 11.75" for 2" stroke, 13.97" for 3" stroke, 17.97" for 4" stroke\*

\* To determine lengths for half inch stroke increments, determine length for next highest whole number stroke and subtract one half inch.

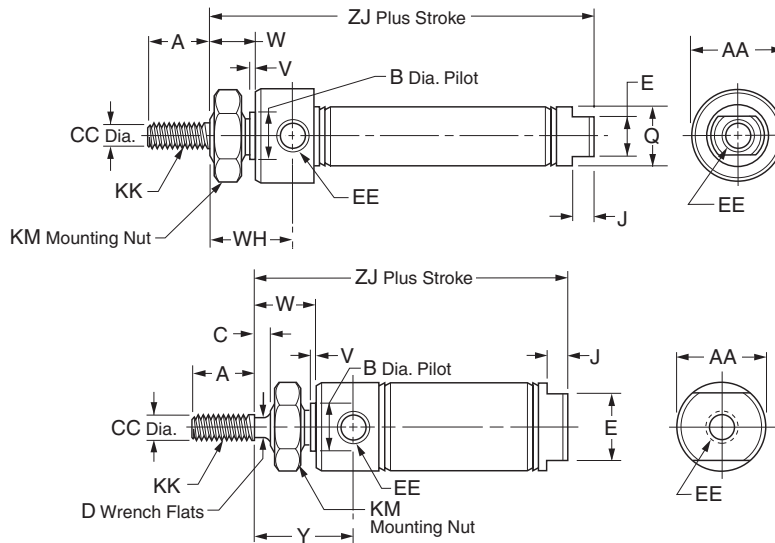


For inventory, lead times, and kit lookup, visit [www.pdnplu.com](http://www.pdnplu.com)

Mounting Style – D

Style D

Nose mount, double acting



Bore sizes

- 5/16"
- 7/16"
- 3/4"

Bore sizes

- 9/16"
- 7/8"
- 1-1/16"
- 1-1/4"
- 1-1/2"
- 1-3/4"
- 2" \*
- 2-1/2" \*
- 3" \*

\* No mounting nuts

Bore size	SR	SRM	SRD SRDM	Std. stroke (in)	Max. stroke (in)	SS rod std	A	AA	B	C	CC
5/16"	•			1/2, 1, 1-1/2, 2, 2-1/2, 3, 4	4	✓	0.38	0.50 SQ.	-	-	0.125
7/16"	•			1/2, 1, 1-1/2, 2, 3, 4	12	✓	0.50	0.74	0.437	-	0.188
9/16"	•	•	•	1/2, 1, 1-1/2, 2, 3, 4	12	✓	0.50	0.62	0.437	-	0.188
3/4"	•	•	•	1/2, 1, 2, 2-1/2, 3, 4, 5, 6, 8, 10	12	✓	0.50	0.86	0.624	-	0.250
7/8"	•			1/2, 1, 2, 3, 4, 5, 6	12	✓	0.50	0.93	0.624	-	0.250
1-1/16"	•	•	•	1/2, 1, 1-1/2, 2, 2-1/2, 3, 4, 5, 6, 8, 10, 12	12	✓	0.50	1.12	0.624	0.12	0.312
1-1/4"	•	•		1, 2, 3, 4, 5, 6	12	✓	0.75	1.34	0.749	0.25	0.437
1-1/2"	•	•	•	1/2, 1, 2, 3, 4, 5, 6, 8, 10, 12	12	✓	0.75	1.56	0.749	0.25	0.437
1-3/4"	•	•		1/2, 1, 1-1/2, 2, 2-1/2, 3, 4, 5, 6	12		0.88	1.84	1.031	0.31	0.500
2"	•	•	•	-	12		0.88	2.08	1.374	0.38	0.625
2-1/2"	•	•		-	12		0.88	2.62	1.500	0.38	0.625
3"	•			-	12		1.25	3.16	1.630	0.38	0.750

Bore size	D	E	EE	J	KK	KM	Q	V	W	WH	Y	SR ZJ	SRM ZJ
5/16"	-	-	#10-32	-	#5-40 UNC	3/8-24	0.36	-	0.31	0.47	-	1.64	-
7/16"	-	0.38	#10-32	0.19	#10-32 UNF	7/16-20	0.50	0.05	0.38	0.72	-	2.12	-
9/16"	-	0.50	#10-32	0.19	#10-32 UNF	7/16-20	-	0.06	0.38	0.78	-	2.28	2.53
3/4"	-	0.62	1/8 NPTF	0.19	1/4-28 UNF	5/8-18	0.81	0.09	0.50	0.97	-	2.97	2.97
7/8"	-	0.62	1/8 NPTF	0.19	1/4-28 UNF	5/8-18	-	0.09	0.50	0.97	-	2.94	-
1-1/16"	0.25	0.88	1/8 NPTF	0.19	5/16-24 UNF	5/8-18	-	0.09	0.62	-	1.19	3.25	3.41
1-1/4"	0.38	0.88	1/8 NPTF	0.25	7/16-20 UNF	3/4-16	-	0.09	0.88	-	1.62	4.00	4.03
1-1/2"	0.38	0.88	1/8 NPTF	0.25	7/16-20 UNF	3/4-16	-	0.09	0.88	-	1.50	3.69	3.94
1-3/4"	7/16	1.25	1/4 NPTF	0.25	1/2-20 UNF	1-14	-	0.09	1.06	1.63	-	4.69	4.69
2"	0.50	1.25	1/4 NPTF	0.31	1/2-20 UNF	1-1/4-12	-	0.12	1.19	-	1.84	4.69	4.97
2-1/2"	1/2	1.75	1/4 NPTF	0.31	1/2-20 UNF	1-3/8-12	-	0.13	1.19	-	1.84	4.69	4.69
3"	5/8	2.00	3/8 NPTF	0.31	5/8-18 UNF	1-1/2-12	-	0.19	1.38	-	2.09	5.25	-



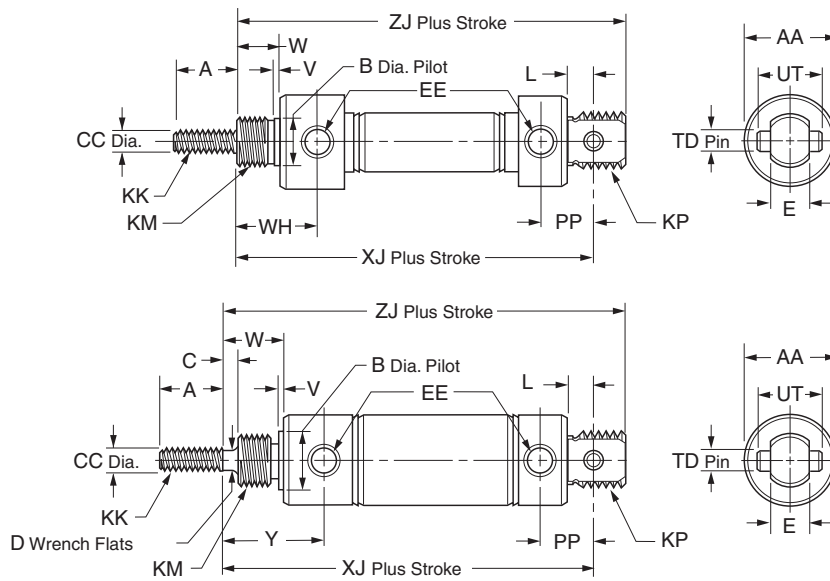
For inventory, lead time, and kit lookup, visit [www.pdnplu.com](http://www.pdnplu.com)



Mounting Style – DP

Style DP

Pivot and nose mount, double acting, pivot pin



Bore sizes

- 5/16"
- 7/16"
- 3/4"

Bore sizes

- 1-1/16"
- 1-1/2"

Round Body  
Pneumatic Cylinders

SR/SRM/SRD/SRDM  
Series

SRG/SRGM  
Series

SRX  
Series

P1A  
Series

P  
Series

Bore size	SR	SRM	Std. stroke (in)	Max. stroke (in)	SS rod	A	AA	B	CC	D	E
7/16"	•		1/2, 1, 1-1/2, 2, 3, 4	12	✓	0.50	0.74	0.437	0.188	-	0.31
3/4"	•	•	1/2, 1, 2, 2-1/2, 3, 4, 5, 6, 8, 10	12	✓	0.50	0.86	0.624	0.250	-	0.38
1-1/16"	•	•	1/2, 1, 1-1/2, 2, 2-1/2, 3, 4, 5, 6, 8, 10, 12	12	✓	0.50	1.12	0.624	0.312	0.25	0.38
1-1/2"	•	•	1, 2, 3, 4, 5, 6, 8, 10, 12	12	✓	0.75	1.56	0.749	0.437	0.38	0.62

Bore size	EE	KK	KM	KP	L	PP	TD	UT	V	W	WH	SR XJ	SRM XJ	Y	SR ZJ	SRM ZJ
7/16"	#10-32	#10-32 UNF	7/16-20	7/16-20 UNF	0.25	0.44	0.156	0.50	0.05	0.38	0.72	2.56	-	-	2.81	-
3/4"	1/8 NPTF	1/4-28 UNF	5/8-18	5/8-18 UNF	0.34	0.62	0.250	0.75	0.09	0.50	0.97	3.75	3.75	-	4.03	4.03
1-1/16"	1/8 NPTF	5/16-24 UNF	5/8-18	5/8-18 UNF	0.34	0.62	0.250	0.75	0.09	0.62	-	3.84	4.00	1.19	4.12	4.28
1-1/2"	1/8 NPTF	7/16-20 UNF	3/4-16	-	0.50	0.81	0.375	1.00	0.09	0.87	-	4.38	4.63	1.50	4.75	5.00



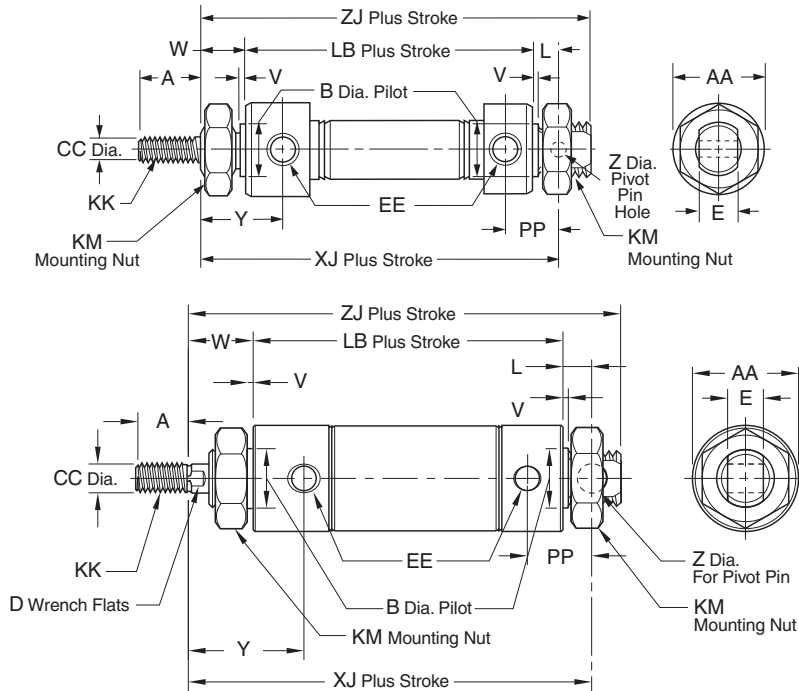
For inventory, lead times, and kit lookup, visit [www.pdnplu.com](http://www.pdnplu.com)

C14

Parker Hannifin Corporation  
Pneumatic Division  
Richland, Michigan  
[www.parker.com/pneumatics](http://www.parker.com/pneumatics)

Style DXP

Pivot & nose mount, double acting, no pivot pin



**Bore sizes**

5/16"
7/16"
3/4"


**Bore sizes**

9/16" *
7/8"
1-1/16"
1-1/4"
1-1/2"
1-3/4"
2" *
2-1/2" *
3" *

\* No mounting nuts

Bore size	SR	SRM	SRD	SRDM	Std. stroke (in)	Max. stroke (in)	SS rod std	A	AA	B	CC	D	E
5/16"	•				1/2, 1, 1-1/2, 2, 2-1/2, 3, 4	4	✓	0.38	0.50 SQ.	-	0.125	-	0.25
7/16"	•				1/2, 1, 1-1/2, 2, 3, 4	12	✓	0.50	0.74	0.437	0.188	-	0.31
9/16"	•	•	•		1/2, 1, 1-1/2, 2, 3, 4	12	✓	0.50	0.62	0.437	0.188	-	0.31
3/4"	•	•	•		1, 2, 3, 4, 5, 6, 8, 10	32	✓	0.50	0.86	0.624	0.250	-	0.38
7/8"	•				1, 2, 3, 4, 5, 6, 8, 10	32	✓	0.50	0.93	0.624	0.250	-	0.38
1-1/16"	•	•	•		1/2, 1, 1-1/2, 2, 2-1/2, 3, 4, 5, 6, 8, 10, 12	32	✓	0.50	1.12	0.624	0.312	0.25	0.38
1-1/4"	•	•			1, 2, 3, 4, 5, 6, 7, 8, 10, 12	32	✓	0.75	1.34	0.749	0.437	0.38	0.50
1-1/2"	•	•	•		-	32	✓	0.75	1.56	0.749	0.437	0.38	0.62
1-3/4"	•	•			1, 2, 3, 4, 5, 6, 8, 10, 12	32		0.88	1.84	1.031	0.500	7/16	0.62
2"	•	•	•		-	32		0.88	2.08	1.374	0.625	0.50	0.75
2-1/2"	•	•			-	32		0.88	2.62	1.500	0.625	1/2	0.75
3"	•				-	32		1.25	3.16	1.630	0.750	5/8	0.88

Bore size	SR								SRM			SR		SRM	
	EE	KK	KM	L	LB	PP	V	W	XJ	XJ	Y	Z	ZJ	ZJ	
5/16"	#10-32	#5-40 UNC	3/8-24	0.19	-	0.34	-	0.31	2.03	-	-	0.125	2.19	-	
7/16"	#10-32	#10-32 UNF	7/16-20	0.25	1.94	0.44	0.05	0.38	2.56	-	0.72	0.157	2.81	-	
9/16"	#10-32	#10-32 UNF	7/16-20	0.25	-	0.38	0.06	0.38	2.56	2.81	0.78	0.157	2.75	3.00	
3/4"	1/8 NPTF	1/4-28 UNF	5/8-18	0.34	2.91	0.62	0.09	0.50	3.75	3.75	0.97	0.251	4.03	4.03	
7/8"	1/8 NPTF	1/4-28 UNF	5/8-18	0.34	-	0.62	0.09	0.50	3.56	-	0.97	0.251	3.84	-	
1-1/16"	1/8 NPTF	5/16-24 UNF	5/8-18	0.34	-	0.62	0.09	0.62	3.84	-	1.19	0.251	4.12	4.28	
1-1/4"	1/8 NPTF	7/16-20 UNF	3/4-16	0.41	-	0.78	0.09	0.88	4.72	4.75	1.62	0.251	5.12	5.16	
1-1/2"	1/8 NPTF	7/16-20 UNF	3/4-16	0.50	-	0.81	0.09	0.88	4.38	4.63	1.50	0.376	4.75	5.00	
1-3/4"	1/4 NPTF	1/2-20 UNF	1-14	0.50	4.19	1.12	0.09	1.06	5.75	5.75	1.94	0.376	6.25	6.25	
2"	1/4 NPTF	1/2-20 UNF	1-1/4-12	0.56	-	1.03	0.12	1.19	5.62	5.91	-	0.376	6.06	6.34	
2-1/2"	1/4 NPTF	1/2-20 UNF	1-3/8-12	0.56	-	1.03	0.13	1.19	5.62	5.62	1.84	0.376	6.06	6.06	
3"	3/8 NPTF	5/8-18 UNF	1-1/2-12	0.81	-	1.34	0.19	1.38	6.50	-	2.09	0.500	7.12	-	

  
 Round Body  
 Pneumatic Cylinders  
 SR/SRM/SRD/SRDM  
 Series  
 SRG/SRGM  
 Series  
 SRX  
 Series  
 P1A  
 Series  
 P  
 Series



For inventory, lead time, and kit lookup, visit [www.pdnplu.com](http://www.pdnplu.com)

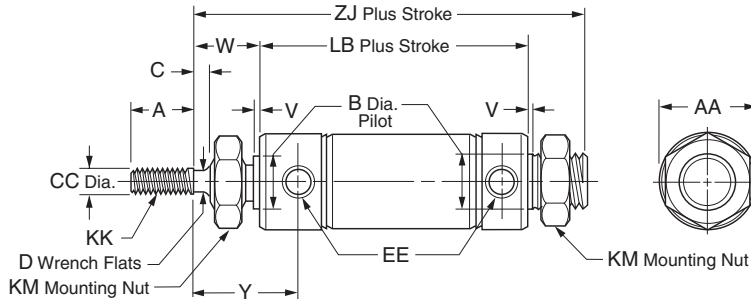
C15

**Parker Hannifin Corporation**  
 Pneumatic Division  
 Richland, Michigan  
[www.parker.com/pneumatics](http://www.parker.com/pneumatics)

Mounting Style – DX

Style DX

Threaded both ends, double acting



**Round Body Pneumatic Cylinders**  
**SR/SRM/SRD/SRDM Series**  
**SRG/SRGM Series**  
**SRX Series**  
**P1A Series**  
**P Series**

Bore size	SR	SRM	Std. stroke (in)	Max. stroke (in)	SS rod std
7/16" *	•		1/2, 1, 1-1/2, 2, 3, 4	12	✓
9/16" *	•	•	1/2, 1, 1-1/2, 2, 3, 4	12	✓
3/4" *	•	•	1, 2, 3, 4, 5, 6, 8, 10	32	✓
7/8" *	•	•	1, 2, 3, 4, 5, 6, 8, 10	32	✓
1-1/16" *	•	•	1/2, 1, 1-1/2, 2, 2-1/2, 3, 4, 5, 6, 8, 10, 12	32	✓
1-1/4" *	•	•	1, 2, 3, 4, 5, 6, 7, 8, 10, 12	32	✓
1-1/2"	•	•	1, 2, 3, 4, 5, 6, 8, 10, 12	32	✓
2" *	•	•	-	32	

Bore size	A	AA	B	C	CC	D	EE	KK	KM	SR		SRM		Y	SR		SRM	
										LB	LB	V	W		ZJ	ZJ	ZJ	ZJ
7/16" *	0.50	0.74	0.437	-	0.188	-	#10-32	#10-32 UNF	7/16-20	1.94	-	0.05	0.38	0.72	2.81	-	-	-
9/16" *	0.50	0.62	0.437	-	0.188	-	#10-32	#10-32 UNF	7/16-20	-	-	0.06	0.38	0.78	2.75	-	-	-
3/4" *	0.50	0.86	0.624	-	0.250	-	1/8 NPTF	1/4-28 UNF	5/8-18	2.91	-	0.09	0.50	0.97	4.03	-	-	-
7/8" *	0.50	0.93	0.624	-	0.250	-	1/8 NPTF	1/4-28 UNF	5/8-18	-	-	0.09	0.50	0.97	3.84	-	-	-
1-1/16" *	0.50	1.12	0.624	0.12	0.312	0.25	1/8 NPTF	5/16-24 UNF	5/8-18	-	-	0.09	0.62	1.19	4.12	-	-	-
1-1/4" *	0.75	0.34	0.749	0.25	0.437	0.38	1/8 NPTF	7/16-20 UNF	3/4-16	-	-	0.09	0.88	1.62	5.12	-	-	-
1-1/2"	0.75	1.56	0.749	0.25	0.437	0.38	1/8 NPTF	7/16-20 UNF	3/4-16	3.00	-	0.09	0.88	1.50	4.50	-	-	-
2" *	0.88	2.08	1.374	0.38	0.625	0.50	1/4 NPTF	1/2-20 UNF	1-1/4-12	-	-	0.12	1.19	-	6.06	-	-	-

\* Available upon request. Please consult factory.

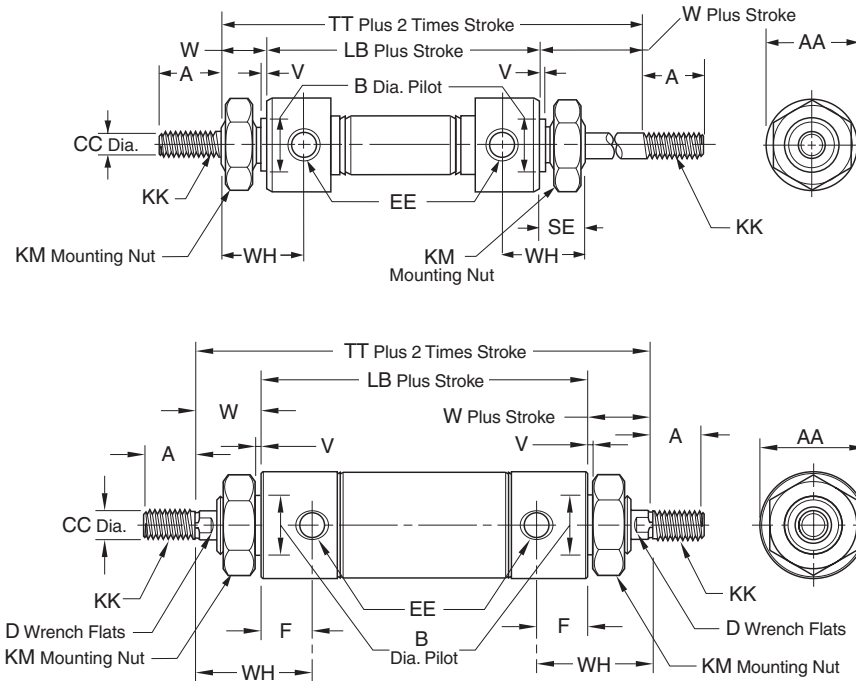


For inventory, lead times, and kit lookup, visit [www.pdnplu.com](http://www.pdnplu.com)



**Style KDX**

Threaded both ends, double acting, double rod



Bore sizes

- 7/16"
- 3/4"

Bore sizes

- 9/16" \*
- 7/8"
- 1-1/16"
- 1-1/4"
- 1-1/2"
- 1-3/4"
- 2" \*
- 2-1/2" \*
- 3" \*

\* No mounting nuts

Bore size	SR	SRM	SRD SRDM	Std. stroke (in)	Max. stroke (in)	SS rod	A	AA	B	CC
7/16"	•			1/2, 1, 1-1/2, 2, 3, 4	6	✓	0.50	0.74	0.437	0.188
9/16"	•	•	•	1/2, 1, 1-1/2, 2, 3, 4	6	✓	0.50	0.62	0.437	0.188
3/4"	•	•	•	1, 2, 3, 4, 5, 6	12	✓	0.50	0.86	0.624	0.250
7/8"	•			1, 2, 3, 4, 6	12	✓	0.50	0.93	0.624	0.250
1-1/16"	•	•	•	1, 2, 3, 4, 5, 6	12	✓	0.50	1.12	0.624	0.312
1-1/4"	•	•	•	1, 2, 3, 4, 5, 6	12	✓	0.75	1.34	0.749	0.437
1-1/2"	•	•	•	1, 2, 3, 4, 5, 6	12	✓	0.75	1.56	0.749	0.437
1-3/4"	•	•		1, 2, 3, 4, 5, 6	12	✓	0.88	1.84	1.031	0.500
2"	•	•	•	–	12	✓	0.88	2.08	1.374	0.625
2-1/2"	•	•		–	18	✓	0.88	2.62	1.500	0.625
3"	•			–	12	✓	1.25	3.16	1.630	0.750

Bore size	D	EE	F	KK	KM	SR		SE	SRM		V	W	WH
						LB	LB		TT	TT			
7/16"	–	#10-32	0.34	#10-32 UNF	7/16-20	2.06	–	0.38	2.81	–	0.05	0.38	0.72
9/16"	–	#10-32	0.40	#10-32 UNF	7/16-20	2.19	2.44	0.38	2.94	3.19	0.06	0.38	0.78
3/4"	–	1/8 NPTF	0.47	1/4-28 UNF	5/8-18	3.00	3.00	0.50	4.00	4.00	0.09	0.50	0.97
7/8"	–	1/8 NPTF	0.47	1/4-28 UNF	5/8-18	2.91	–	0.50	3.91	–	0.09	0.50	0.97
1-1/16"	0.25	1/8 NPTF	0.56	5/16-24 UNF	5/8-18	2.75	3.28	0.50	4.00	4.53	0.09	0.62	1.19
1-1/4"	0.38	1/8 NPTF	0.75	7/16-20 UNF	3/4-16	3.81	3.84	0.63	5.56	5.59	0.09	0.88	1.62
1-1/2"	0.38	1/8 NPTF	0.62	7/16-20 UNF	3/4-16	3.38	3.63	0.63	5.12	5.38	0.09	0.88	1.50
1-3/4"	7/16	1/4 NPTF	0.88	1/2-20 UNF	1-14	4.44	4.69	0.75	6.56	6.81	0.09	1.06	1.94
2"	0.50	1/4 NPTF	0.65	1/2-20 UNF	1-1/4-12	4.19	4.47	–	6.56	6.84	0.12	1.19	1.84
2-1/2"	1/2	1/4 NPTF	0.65	1/2-20 UNF	1-3/8-12	4.19	4.19	–	6.56	6.56	0.13	1.19	1.84
3"	5/8	3/8 NPTF	0.71	5/8-18 UNF	1-1/2-12	4.56	–	–	7.31	–	0.19	1.38	2.09

**Round Body**  
**Pneumatic Cylinders**

---

**SR/SRM/SRD/SRDM**  
**Series**

---

**SRG/SRGM**  
**Series**

---

**SRX**  
**Series**

---

**P1A**  
**Series**

---

**P**  
**Series**

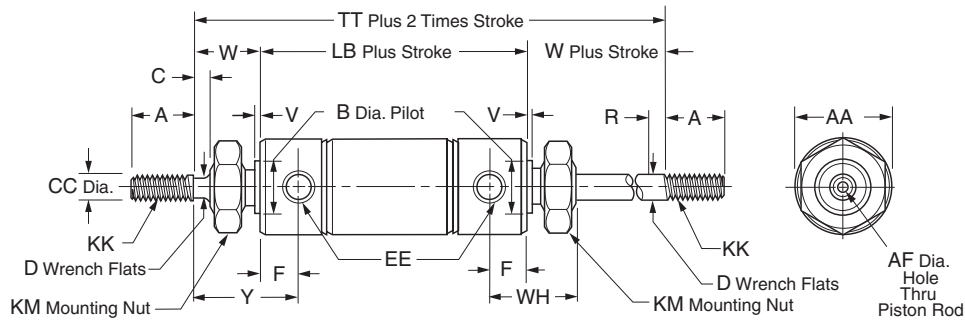


For inventory, lead time, and kit lookup, visit [www.pdnplu.com](http://www.pdnplu.com)

Mounting Style – KDXH, A

Style KDXH

Threaded both ends, double rod, hollow rod

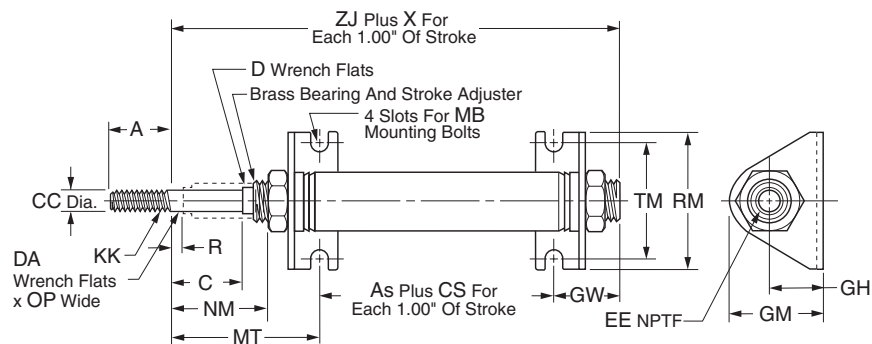


Bore size	SR	SRM	Std. stroke (in)	Max. stroke (in)	SS rod	A	AA	AF	B	C	CC
1-1/16"	•	•	1, 2, 3, 4, 5, 6	12	N/A	0.50	1.12	0.187	0.624	0.12	0.312
1-1/4"	•	•	1, 2, 3, 4, 5, 6	12	N/A	0.75	1.34	0.250	0.749	0.25	0.437
1-1/2"	•	•	1, 2, 3, 4, 5, 6	12	N/A	0.75	1.56	0.250	0.749	0.25	0.437
1-3/4"	•	•	1, 2, 3, 4, 5, 6	12	N/A	0.88	1.84	0.328	1.031	0.38	0.500

Bore size	D	EE	F	KK	KM	LB SR	SRM	R	TT SR	SRM	V	W	WH	Y
1-1/16"	0.25	1/8 NPTF	0.56	5/16-24 UNF	5/8-18	2.75	3.28	0.12	4.00	4.53	0.09	0.62	1.06	1.19
1-1/4"	0.38	1/8 NPTF	0.75	7/16-20 UNF	3/4-16	3.81	3.84	0.25	5.56	5.59	0.09	0.88	1.38	1.62
1-1/2"	0.38	1/8 NPTF	0.62	7/16-20 UNF	3/4-16	3.38	3.63	0.25	5.12	5.38	0.09	0.88	1.25	1.50
1-3/4"	7/16	1/4 NPTF	0.88	1/2-20 UNF	1-14	4.44	4.44	-	6.56	6.56	0.09	1.06	1.63	1.63

Style A

Nose mount, spring return, head adjustable stroke



Bore size	SR	SRM	Std. stroke	Max. stroke (in)	SS rod std	A	AS	C	CC	CS	D
3/4"	•	•	Stroke adjustment in 1" increments to 3": 1" stroke adjusts 0-1" 2" stroke adjusts 1-2" 3" stroke adjusts 2-3"	6	✓	0.50	-	1.19	0.250	1.69	-
1-1/16"	•	•		6	✓	0.50	0.32	1.25	0.312	1.56	0.25
1-1/2"	•	•		6	✓	0.75	0.19	1.25	0.437	2.00	0.62

Bore size	EE	GH	GM	GW	KK	MB	MT	NM	OP	R	RM	TM	X	ZJ
3/4"	1/8 NPTF	0.81	1.38	0.88	1/4-28 UNF	0.250	2.38	1.44	-	0.19	1.88	1.50	1.69	3.12
1-1/16"	1/8 NPTF	0.81	1.38	0.93	5/16-24 UNF	0.250	2.38	1.44	0.12	0.25	1.88	1.50	1.56	3.63
1-1/2"	1/8 NPTF	1.00	1.78	1.25	7/16-20 UNF	0.250	2.56	1.50	-	0.25	2.50	1.88	2.00	4.00

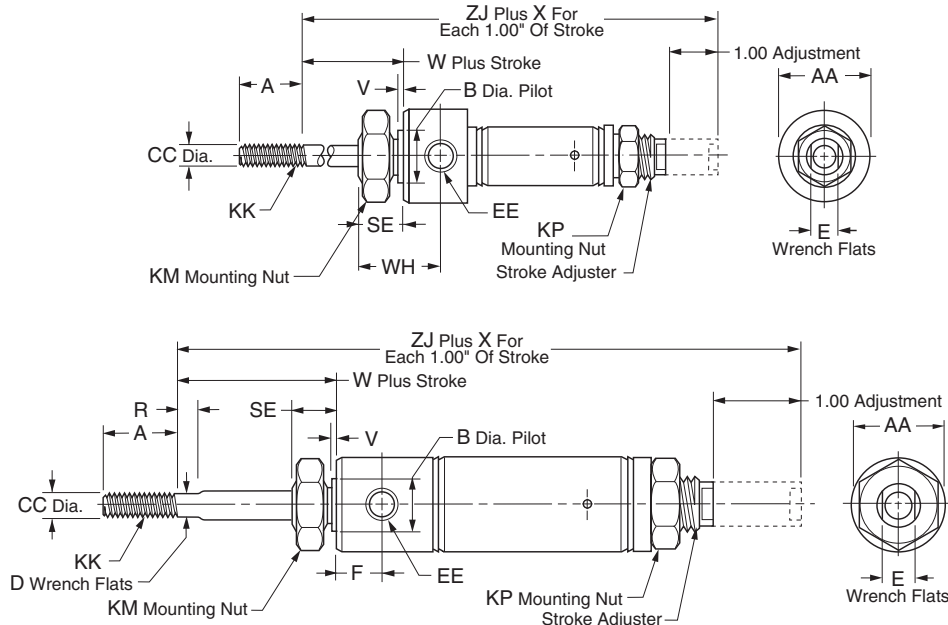


For inventory, lead times, and kit lookup, visit [www.pdnplu.com](http://www.pdnplu.com)

Mounting Style – RA

Style RA

Nose mount, spring extend, cap adjustable stroke




Bore sizes
3/4"

Bore sizes
1-1/16"
1-1/2"


Bore size	SR	SRM	Std. stroke	Max. stroke (in)	SS rod std
3/4"	•		Stroke adjustment in 1" increments to 3":	6	✓
1-1/16"	•		1" stroke adjusts 0-1"	6	✓
			2" stroke adjusts 1-2"		
1-1/2"	•		3" stroke adjusts 2-3"	6	✓

Bore size	A	AS	AA	B	CC	D	E	EE	F
3/4"	0.50	1.69	0.86	0.624	0.250	-	0.34	1/8 NPTF	-
1-1/16"	0.50	0.32	1.12	0.624	0.312	0.25	0.50	1/8 NPTF	0.56
1-1/2"	1.25	0.19	1.56	0.749	0.437	0.38	0.62	1/8 NPTF	0.62

Bore size	KK	KM	SE	R	V	W	WH	X	ZJ
3/4"	1/4-28 UNF	5/8-18	0.50	-	0.09	0.53	0.97	2.69	3.78
1-1/16"	5/16-24 UNF	5/8-18	0.50	0.12	0.09	0.50	-	2.56	4.03
1-1/2"	7/16-20 UNF	3/4-16	0.62	0.25	0.09	0.88	-	3.00	4.81

  
 Round Body  
 Pneumatic Cylinders  
 SR/SRM/SRD/SRDM  
 Series  
 SRG/SRGM  
 Series  
 SRX  
 Series  
 P1A  
 Series  
 P  
 Series



 For inventory, lead time, and kit lookup, visit [www.pdnplu.com](http://www.pdnplu.com)

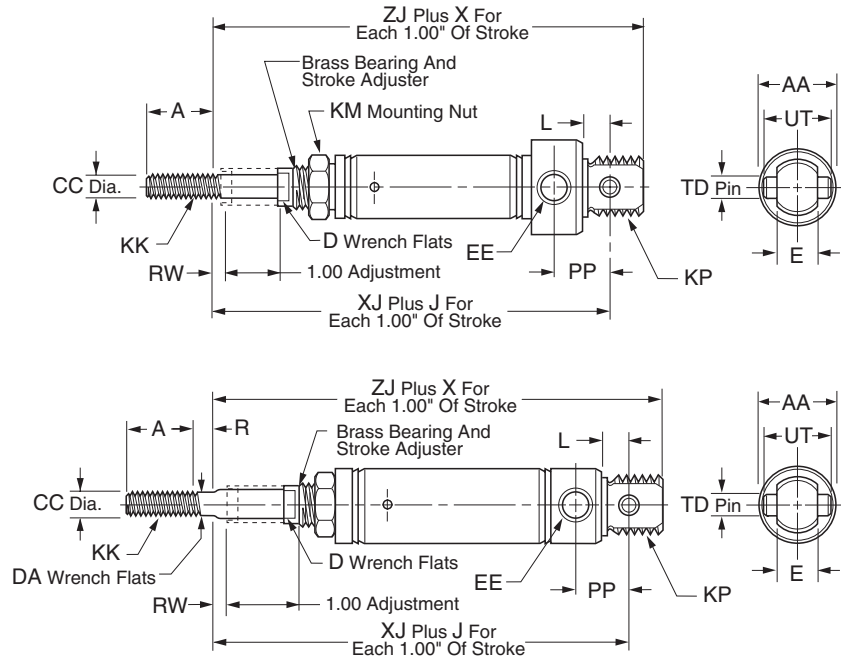
C19

**Parker Hannifin Corporation**  
 Pneumatic Division  
 Richland, Michigan  
[www.parker.com/pneumatics](http://www.parker.com/pneumatics)

Mounting Style – AP

Style AP

Pivot mount, spring return, head adjustable stroke



Bore sizes

3/4"

Bore sizes

1-1/16"

1-1/2"

Bore size	SR	SRM	Std. stroke	Max. stroke (in)	SS rod std
3/4"	•		Stroke adjustment in 1" increments to 3":	6	✓
1-1/16"	•		1" stroke adjusts 0-1" 2" stroke adjusts 1-2"	6	✓
1-1/2"	•		3" stroke adjusts 2-3"	6	✓

Bore size	A	AA	CC	D	DA	E	EE	J	KK
3/4"	0.50	0.86	0.250	0.34	–	0.38	1/8 NPTF	1.69	1/4-28 UNF
1-1/16"	0.50	1.12	0.312	0.50	0.25	0.38	1/8 NPTF	1.56	5/16-24 UNF
1-1/2"	0.75	1.56	0.437	0.62	0.38	0.62	1/8 NPTF	2.00	7/16-20 UNF

Bore size	KM	KP	L	OP	PP	R	RW	TD	UT	X	XJ	ZJ
3/4"	7/16-20	5/8-18 UNF	0.34	–	0.62	0.19	0.19	0.250	0.75	1.69	3.65	3.93
1-1/16"	–	5/8-18 UNF	0.34	0.25	0.62	0.12	0.25	0.250	0.75	1.56	3.97	4.25
1-1/2"	3/4-16	–	0.50	–	0.81	0.25	0.25	0.375	1.00	2.00	4.31	4.69

C  
Round Body  
Pneumatic Cylinders  
SR/SRM/SRD/SRDM  
Series  
SRG/SRGM  
Series  
SRX  
Series  
P1A  
Series  
P  
Series



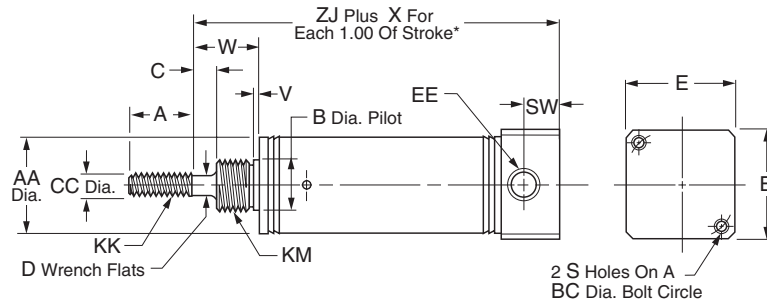
For inventory, lead times, and kit lookup, visit [www.pdnplu.com](http://www.pdnplu.com)

C20

Parker Hannifin Corporation  
Pneumatic Division  
Richland, Michigan  
[www.parker.com/pneumatics](http://www.parker.com/pneumatics)

**Style BRN**

Rear block mount, single acting, spring return



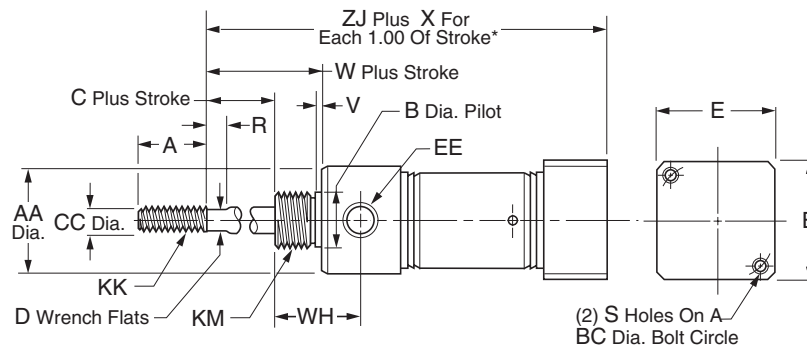
Bore size	SR	SRM	Std. stroke (in)	Max. stroke (in)	SS rod std	A	AA	B	C	CC	D
7/16"	•		1/2, 1, 2, 3, 4	6	✓	0.50	0.5	0.374	–	0.188	–
3/4"	•	•	1, 2, 3, 4	6	✓	0.75	0.81	0.499	0.25	0.250	0.22
1-1/16"	•	•	1, 2, 3, 4	6	✓	0.75	1.12	0.624	0.38	0.312	0.25
1-1/2"	•	•	1, 2, 3, 4	6	✓	1.25	1.56	0.749	0.25	0.437	0.38

Bore size	E	EE	KK	KM	SW	V	W	X	SR ZJ	SRM ZJ
7/16"	0.75	#10-32	#10-32 UNF	3/8-24	0.38	0.05	0.31	0.94	1.62	–
3/4"	1.00	1/8 NPTF	1/4-28 UNF	1/2-20	0.44	0.09	0.62	1.69	2.31	2.56
1-1/16"	1.25	1/8 NPTF	5/16-24 UNF	5/8-18	0.44	0.09	0.88	1.81	2.81	3.06
1-1/2"	1.75	1/4 NPTF	7/16-20 UNF	3/4-16	0.62	0.09	0.88	2.00	3.06	3.31

\* To determine lengths for half inch stroke increments, determine length for next highest whole number stroke and subtract one half inch.

**Style BRR**

Rear block mount, single acting, spring extend



Bore size	SR	SRM	Std. stroke (in)	Max. stroke (in)	SS rod std	A	AA	B	BC	C	CC	D
3/4"	•	•	1, 2, 3, 4	6	✓	0.75	0.86	0.624	1.00	0.25	0.250	0.22
1-1/16"	•	•	1, 2, 3, 4	6	✓	0.75	1.12	0.624	1.25	0.38	0.312	0.25
1-1/2"	•	•	1, 2, 3, 4	6	✓	1.25	1.56	0.749	1.75	0.25	0.437	0.38

Bore size	E	EE	KK	KM	R	S	V	W	WH	X	ZJ SR	ZJ SRM
3/4"	1.00	1/8 NPTF	1/4-28 UNF	5/8-18	0.25	#10-32 UNF	0.09	0.75	0.97	2.69	3.22	3.47
1-1/16"	1.25	1/8 NPTF	5/16-24 UNF	5/8-18	0.25	#10-32 UNF	0.09	0.88	1.06	2.81	3.53	3.78
1-1/2"	1.75	1/4 NPTF	7/16-20 UNF	3/4-16	0.25	1/4-20 UNC	0.09	0.88	1.25	3.00	3.88	4.13

\* To determine lengths for half inch stroke increments, determine length for next highest whole number stroke and subtract one half inch.

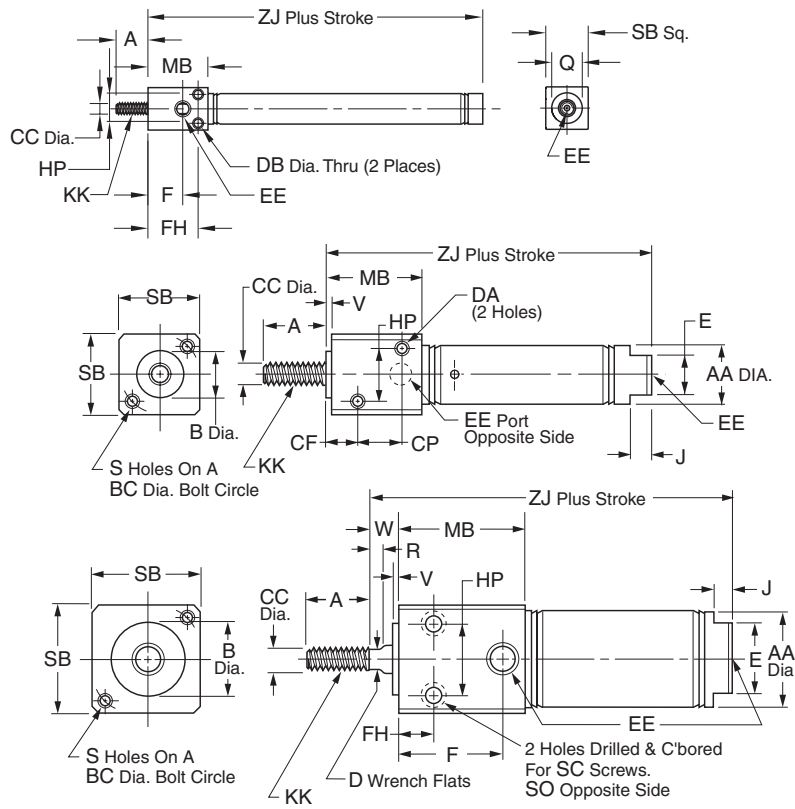
Round Body Pneumatic Cylinders  
 SR/SRM/SRD/SRDM Series  
 SRG/SRGM Series  
 SRX Series  
 P1A Series  
 P Series



For inventory, lead time, and kit lookup, visit [www.pdnplu.com](http://www.pdnplu.com)

Style BFD

Front block mount, double acting



Bore sizes
5/16"

Bore sizes
7/16"

Bore sizes
3/4"
1-1/16"
1-1/2"

Bore size	SR	SRM	Std. stroke (in)	Max. stroke (in)	SS rod std	A	AA	B	BC	CC
5/16"	•		1/2, 1, 1-1/2, 2, 2-1/2, 3, 4	4	✓	0.38	-	-	-	0.125
7/16"	•		1/2, 1, 1-1/2, 2, 3, 4	12	✓	0.50	0.50	0.437	0.75	0.188
3/4"	•	•	1/2, 1, 2, 3, 4, 5, 6	12	✓	0.75	0.81	0.624	1.00	0.250
1-1/16"	•	•	1, 2, 3, 4, 5, 6	12	✓	0.75	1.12	0.750	1.25	0.312
1-1/2"	•	•	1, 2, 3, 4, 5, 6	12	✓	1.25	1.56	1.00	1.75	0.437

Bore size	CF	CP	D	DA	DB	E	EE	F	FH	HP	J
5/16"	-	-	-	-	0.11	-	#10-32	0.41	0.59	0.34	-
7/16"	0.31	0.44	-	#8-32	-	0.38	#10-32	-	0.31	0.44	0.19
3/4"	-	-	0.22	-	-	0.62	1/8 NPTF	0.88	0.38	0.62	0.19
1-1/16"	-	-	0.25	-	-	0.88	1/8 NPTF	1.16	0.62	0.81	0.19
1-1/2"	-	-	0.38	-	-	0.88	1/4 NPTF	1.53	0.88	1.12	0.25

Bore size	KK	MB	Q	R	S	SB	SC	SO	V	W	SR ZJ	SRM ZJ
5/16"	#5-40 UNC	0.71	0.36	-	-	0.50 SQ	-	-	-	-	1.72	-
7/16"	#10-32 UNF	0.88	-	-	#8-32 UNC	0.75	-	-	0.062	-	2.12	-
3/4"	1/4-28 UNF	1.12	-	-	#10-32 UNF	1.00	#10-32	1/4-20 UNC	0.093	0.34	3.22	3.22
1-1/16"	5/16-24 UNF	1.41	-	0.25	#10-32 UNF	1.25	#10-32	1/4-20 UNC	0.093	0.47	3.75	3.91
1-1/2"	7/16-20 UNF	1.88	-	-	1/4-20 UNC	1.75	1/4-20	5/16-18 UNC	0.125	0.38	4.19	4.44



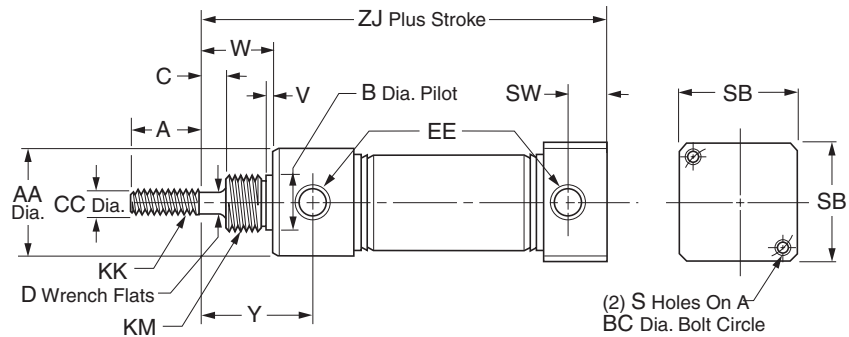
For inventory, lead times, and kit lookup, visit [www.pdnplu.com](http://www.pdnplu.com)

C22

Parker Hannifin Corporation  
Pneumatic Division  
Richland, Michigan  
[www.parker.com/pneumatics](http://www.parker.com/pneumatics)

**Style BRD**


Rear block mount, double acting



Bore size	SR	SRM	Std. stroke (in)	Max. stroke (in)	SS rod std
7/16"	•		1/2, 1, 2, 3, 4	12	✓
3/4"	•	•	1, 2, 3, 4, 5, 6	12	✓
1-1/16"	•	•	1, 2, 3, 4	12	✓
1-1/2"	•	•	1, 2, 3, 4, 5, 6	12	✓

Bore size	A	AA	B	BC	C	CC	D	EE	KK
7/16"	0.50	0.74	0.437	0.75	–	0.188	–	#10-32	#10-32 UNF
3/4"	0.75	0.86	0.624	1.00	0.25	0.250	0.22	1/8 NPTF	1/4-28 UNF
1-1/16"	0.75	1.12	0.624	1.25	0.38	0.312	0.25	1/8 NPTF	5/16-24 UNF
1-1/2"	1.25	1.56	0.749	1.75	0.25	0.437	0.38	1/4 NPTF	7/16-20 UNF

Bore size	KM	S	SB	SW	V	W	Y	SR		SRM	
								ZJ	ZJ	ZJ	ZJ
7/16"	7/16-20 UNF	#8-32 UNC	0.75	0.38	0.05	0.43	0.72	2.44	–		
3/4"	5/8-18 UNF	#10-32 UNF	1.00	0.44	0.09	0.75	1.22	3.78	3.78		
1-1/16"	5/8-18 UNF	#10-32 UNF	1.25	0.44	0.09	0.88	1.44	4.00	4.16		
1-1/2"	3/4-16 UNF	1/4-20 UNC	1.75	0.62	0.09	0.88	1.47	4.38	4.63		

  
**Round Body  
Pneumatic Cylinders**

---

**SR/SRM/SRD/SRDM  
Series**

---

**SRG/SRGM  
Series**

---

**SRX  
Series**

---

**P1A  
Series**

---

**P  
Series**



For inventory, lead time, and kit lookup, visit [www.pdnplu.com](http://www.pdnplu.com)

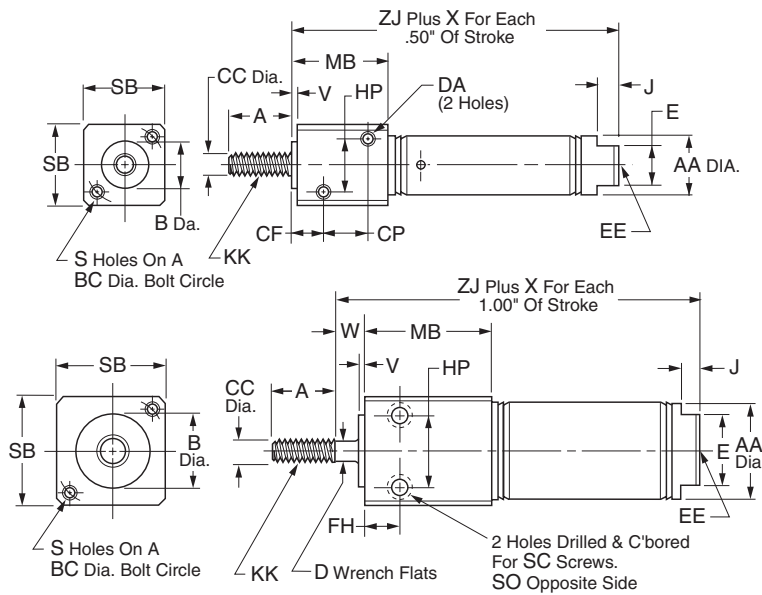
Mounting Style – BFN

Style BFN

Front block mount, single acting, spring return

Bore sizes

7/16"



Bore sizes

3/4"

1-1/16"

1-1/2"

Round Body  
Pneumatic Cylinders

SR/SRM/SRD/SRDM  
Series

SRG/SRGM  
Series

SRX  
Series

P1A  
Series

P  
Series

Bore size	SR	SRM	Std. stroke (in)	Max stroke (in)	SS rod std
7/16"	•		1/2, 1, 1-1/2, 2, 3	6	✓
3/4"	•	•	1/2, 1, 2, 3, 4	6	✓
1-1/16"	•	•	1, 2, 3, 4	6	✓
1-1/2"	•	•	1, 2, 3, 4	6	✓

Bore size	A	AA	B	BC	CC	CF	CP	D	DA	E	EE	FH
7/16"	0.50	0.50	0.437	0.75	0.188	0.31	0.44	-	#8-32 UNC	0.38	#10-32	0.31
3/4"	0.75	0.81	0.624	1.00	0.250	-	-	0.22	-	0.62	1/8 NPTF	0.38
1-1/16"	0.75	1.12	0.750	1.25	0.312	-	-	0.25	-	0.88	1/8 NPTF	0.62
1-1/2"	1.25	1.56	1.00	1.75	0.437	-	-	0.38	-	0.88	1/4 NPTF	0.88

Bore size	HP	J	KK	MB	S	SB	SC	SO	V	W	X	SR		SRM	
												ZJ	ZJ	ZJ	ZJ
7/16"	0.44	0.19	#10-32 UNF	0.88	#8-32 UNC	0.75	-	-	0.062	-	0.94	1.94	-	-	
3/4"	0.62	0.19	1/4-28 UNF	1.12	#10-32 UNF	1.00	#10-32	1/4-20 UNC	0.093	0.34	1.69	2.66	2.91		
1-1/16"	0.81	0.19	5/16-24 UNF	1.41	#10-32 UNF	1.25	#10-32	1/4-20 UNC	0.093	0.47	1.81	3.38	3.63		
1-1/2"	1.12	0.25	7/16-20 UNF	1.88	1/4 UNC	1.75	1/4-20	5/16-18 UNC	0.125	0.38	2.00	3.69	3.94		

\* To determine lengths for half inch stroke increments, determine length for next highest whole number stroke and subtract one half inch.



For inventory, lead times, and kit lookup, visit [www.pdnplu.com](http://www.pdnplu.com)

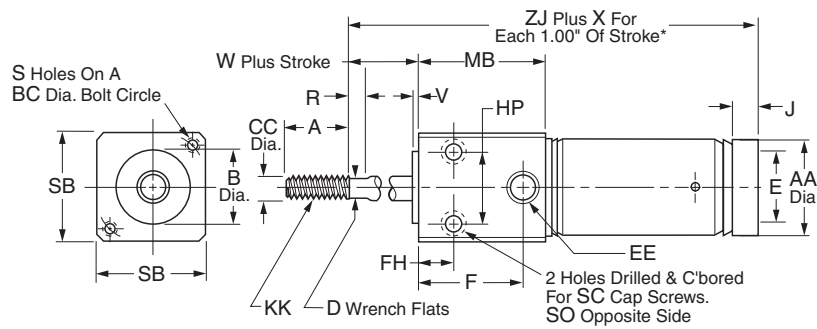
C24

Parker Hannifin Corporation  
Pneumatic Division  
Richland, Michigan  
[www.parker.com/pneumatics](http://www.parker.com/pneumatics)



**Style BFR**

Front block mount, single acting, spring extend




Bore size	SR	SRM	Std. stroke (in)	Max stroke (in)	SS rod std
3/4"	•	•	1, 2, 3, 4	6	✓
1-1/16"	•	•	1, 2, 3, 4	6	✓
1-1/2"	•	•	1, 2, 3, 4	6	✓

Bore size	A	AA	B	BC	CC	D	E	EE	F	FH	HP	J
3/4"	0.75	0.81	0.624	1.00	0.250	0.22	-	1/8 NPTF	0.88	0.38	0.62	0.19
1-1/16"	0.75	1.12	0.750	1.25	0.312	0.25	-	1/8 NPTF	1.16	0.62	0.81	-
1-1/2"	1.25	1.56	1.00	1.75	0.437	0.38	0.88	1/4 NPTF	1.53	0.88	1.12	0.25

Bore size	KK	MB	R	S	SB	SC	SO	V	W	X	SR		SRM
											ZJ	ZJ	ZJ
3/4"	1/4-28 UNF	1.12	0.25	#10-32 UNF	1.00	#10-32	1/4-20 UNC	0.093	0.34	2.69	2.56	2.81	
1-1/16"	5/16-24 UNF	1.41	0.25	#10-32 UNF	1.25	#10-32	1/4-20 UNC	0.093	0.47	2.81	3.12	3.37	
1-1/2"	7/16-20 UNF	1.88	0.25	1/4-20 UNC	1.75	1/4-20	5/16-18 UNC	0.125	0.38	3.00	3.69	3.94	

\* To determine lengths for half inch stroke increments, determine length for next highest whole number stroke and subtract one half inch.

  
 Round Body  
 Pneumatic Cylinders  
 SR/SRM/SRD/SRDM  
 Series  
 SRG/SRGM  
 Series  
 SRX  
 Series  
 P1A  
 Series  
 P  
 Series

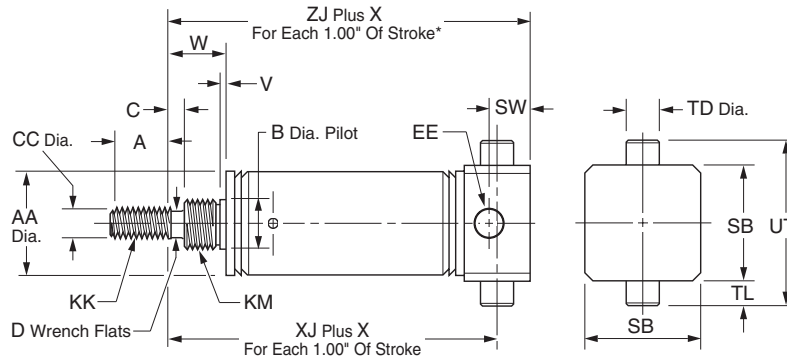


For inventory, lead time, and kit lookup, visit [www.pdnplu.com](http://www.pdnplu.com)

Mounting Style – TRN, TRR

Style TRN

Rear trunnion mount, single acting, spring return



Bore size	SR	SRM	Std. stroke (in)	Max. stroke (in)	SS rod std	A	AA	B	C	CC	D	EE
7/16"	•		1/2, 1, 2, 3, 4	6	✓	0.50	0.50	0.374	–	0.188	–	#10-32
3/4"	•	•	1, 2, 3, 4	6	✓	0.75	0.81	0.499	0.25	0.250	0.22	1/8 NPTF
1-1/16"	•	•	1, 2, 3, 4	6	✓	0.75	1.12	0.624	0.38	0.312	0.25	1/8 NPTF
1-1/2"	•	•	1, 2, 3, 4	6	✓	1.25	1.56	0.749	0.25	0.437	0.38	1/4 NPTF

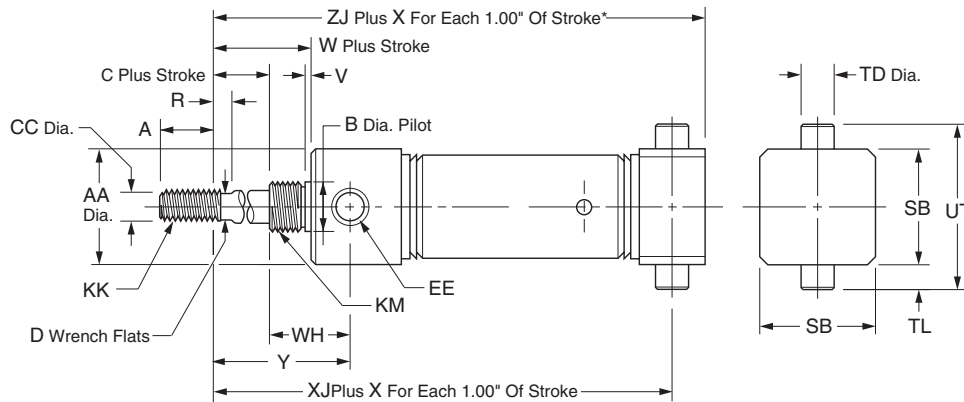
Bore size	KK	KM	SB	SW	TD	TL	UT	V	W	X	SR XJ	SRM XJ	SR ZJ	SRM ZJ
7/16"	#10-32 UNF	3/8-24 UNF	0.75	0.38	0.374	0.50	1.25	0.05	0.32	0.94**	1.38	–	1.62	–
3/4"	1/4-28 UNF	1/2-20 UNF	1.00	0.44	0.500	0.38	1.75	0.09	0.62	1.69	1.94	2.19	2.31	2.56
1-1/16"	5/16-24 UNF	5/8-18 UNF	1.25	0.44	0.500	0.38	2.00	0.09	0.88	1.81	2.44	2.69	2.81	3.06
1-1/2"	7/16-20 UNF	3/4-16 UNF	1.75	0.62	0.500	0.38	2.50	0.09	0.88	2.00	2.56	2.81	3.06	3.31

\* To determine lengths for half inch stroke increments, determine length for next highest whole number stroke and subtract one half inch.

\*\* For each 0.50" of stroke.

Style TRR

Rear trunnion mount, single acting, spring extend



Bore size	SR	SRM	Std. stroke (in)	Max. stroke (in)	SS rod std	A	AA	B	C	CC	D	EE
3/4"	•	•	1, 2, 3, 4	6	3	0.75	0.86	0.624	0.25	0.250	0.22	1/8 NPTF
1-1/16"	•	•	1, 2, 3, 4	6	3	0.75	1.12	0.624	0.38	0.312	0.25	1/8 NPTF
1-1/2"	•	•	1, 2, 3, 4	6	3	1.25	1.56	0.749	0.25	0.437	0.38	1/4 NPTF

Bore size	KK	KM	R	SB	TD	TL	UT	V	W	WH	X	SR XJ	SRM XJ	SR ZJ	SRM ZJ
3/4"	1/4-28 UNF	1/2-20 UNF	0.25	1.00	0.500	0.38	1.75	0.09	0.75	0.72	2.69	2.85	3.10	3.22	3.47
1-1/16"	5/16-24 UNF	5/8-18 UNF	0.25	1.25	0.500	0.38	2.00	0.09	0.88	0.68	2.81	3.15	3.40	3.53	3.78
1-1/2"	7/16-20 UNF	3/4-16 UNF	0.25	1.75	0.500	0.38	2.50	0.09	0.88	1.25	3.00	3.38	3.63	3.88	4.13

\* To determine lengths for half inch stroke increments, determine length for next highest whole number stroke and subtract one half inch.

Round Body Pneumatic Cylinders  
 SR/SRM/SRD/SRDM Series  
 SRG/SRGM Series  
 SRX Series  
 P1A Series  
 P Series



For inventory, lead times, and kit lookup, visit [www.pdnplu.com](http://www.pdnplu.com)

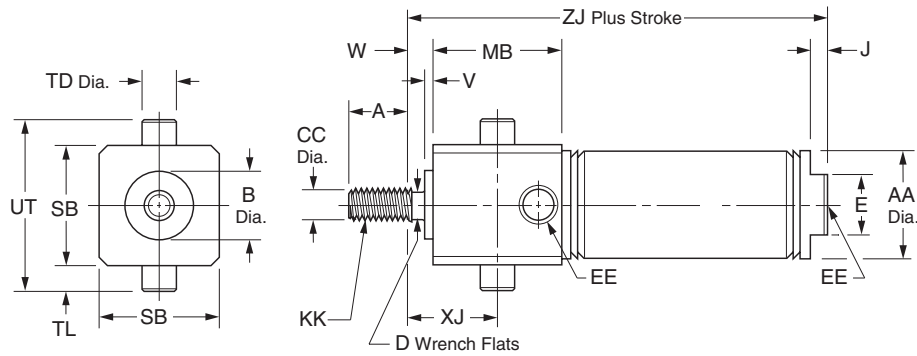
C26

**Parker Hannifin Corporation**  
Pneumatic Division  
Richland, Michigan  
[www.parker.com/pneumatics](http://www.parker.com/pneumatics)

Mounting Style – TFD, TRD

Style TFD

Front trunnion mount, double acting

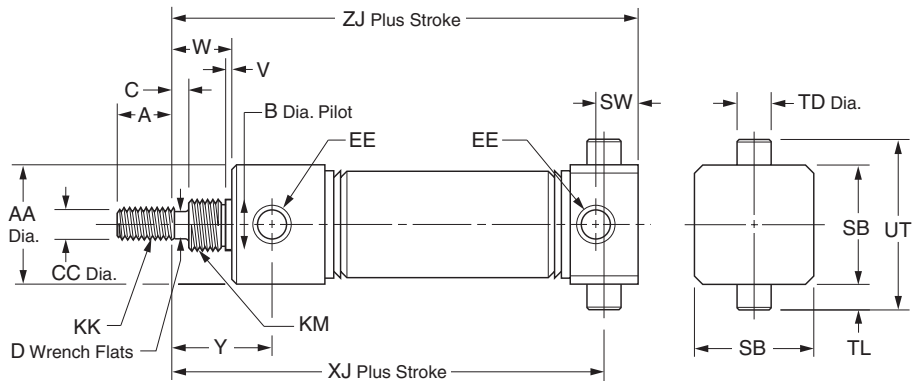


Bore size	SR	SRM	Std. stroke (in)	Max. stroke (in)	SS rod std	A	AA	B	CC	D	E	EE
7/16"	•		1/2, 1, 1-1/2, 2, 3, 4	12	✓	0.50	0.50	0.437	0.188	–	0.38	#10-32
3/4"	•	•	1, 2, 3, 4, 5, 6	12	✓	0.75	0.81	0.624	0.250	0.22	0.62	1/8 NPTF
1-1/16"	•	•	1, 2, 3, 4, 5, 6	12	✓	0.75	1.12	0.750	0.312	0.25	0.88	1/8 NPTF
1-1/2"	•	•	1, 2, 3, 4, 5, 6	12	✓	1.25	1.56	1.000	0.437	0.38	0.88	1/4 NPTF

Bore size	J	KK	MB	SB	TD	TL	UT	V	W	XJ	SR ZJ	SRM ZJ
7/16"	0.19	#10-32 UNF	0.88	0.75	0.374	0.250	1.25	0.062	–	0.31	2.12	–
3/4"	0.19	1/4-28 UNF	1.12	1.00	0.500	0.38	1.75	0.093	0.34	0.69	3.22	3.22
1-1/16"	0.19	5/16-24 UNF	1.41	1.25	0.500	0.38	2.00	0.093	0.47	1.09	3.75	3.91
1-1/2"	0.25	7/16-20 UNF	1.88	1.75	0.500	0.38	2.50	0.125	0.38	1.31	4.19	4.44

Style TRD

Rear trunnion mount, double acting



Bore size	SR	SRM	Std. stroke (in)	Max. stroke (in)	SS rod std	A	AA	B	C	CC	D	EE
7/16"	•		1/2, 1, 1-1/2, 2, 3, 4	12	✓	0.50	0.74	0.437	–	0.188	–	#10-32
3/4"	•	•	1, 2, 3, 4, 5, 6	12	✓	0.75	0.86	0.624	0.25	0.250	0.22	1/8 NPTF
1-1/16"	•	•	1, 2, 3, 4	12	✓	0.75	1.12	0.624	0.38	0.312	0.25	1/8 NPTF
1-1/2"	•	•	1, 2, 3, 4, 5, 6	12	✓	1.25	1.56	0.749	0.25	0.437	0.38	1/4 NPTF

Bore size	KK	KM	SB	SW	TD	TL	UT	V	W	SR XJ	SRM XJ	Y	SR ZJ	SRM ZJ
7/16"	1/4-28 UNF	5/8-18 UNF	0.75	0.38	0.374	0.25	1.25	0.05	0.38	2.19	–	0.72	2.44	–
3/4"	5/16-24 UNF	5/8-18 UNF	1.00	0.44	0.500	0.38	1.75	0.09	0.75	3.41	3.41	1.22	3.78	3.78
1-1/16"	7/16-20 UNF	3/4-16 UNF	1.25	0.44	0.500	0.38	2.00	0.09	0.88	3.62	3.62	1.44	4.00	4.16
1-1/2"			1.75	0.62	0.500	0.38	2.50	0.09	0.88	3.88	4.13	1.47	4.38	4.63



Round Body  
Pneumatic Cylinders

SR/SRM/SRD/SRDM  
Series

SRG/SRGM  
Series

SRX  
Series

P1A  
Series

P  
Series



For inventory, lead time, and kit lookup, visit [www.pdnplu.com](http://www.pdnplu.com)

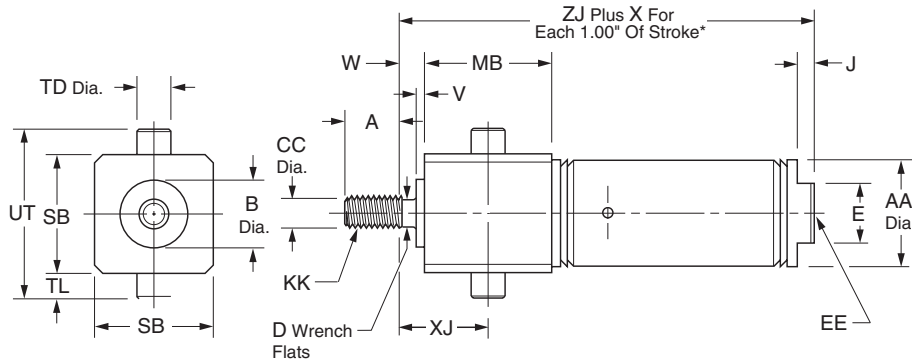
C27

Parker Hannifin Corporation  
Pneumatic Division  
Richland, Michigan  
[www.parker.com/pneumatics](http://www.parker.com/pneumatics)

Mounting Style – TFN, TFR

Style TFN

Front trunnion mount, single acting, spring return



Bore size	SR	SRM	Std. stroke (in)	Max. stroke (in)	SS rod std	A	AA	B	CC	D	E	EE
7/16"	•		1/2, 1, 1-1/2, 2, 3	6	✓	0.50	0.50	0.437	0.188	–	0.38	#10-32
3/4"	•	•	1/2, 1, 2, 3, 4	6	✓	0.75	0.81	0.624	0.250	0.22	0.62	1/8 NPTF
1-1/16"	•	•	1, 2, 3, 4	6	✓	0.75	1.12	0.750	0.312	0.25	0.88	1/8 NPTF
1-1/2"	•	•	1, 2, 3, 4	6	✓	1.25	1.56	1.000	0.437	0.38	0.88	1/4 NPTF

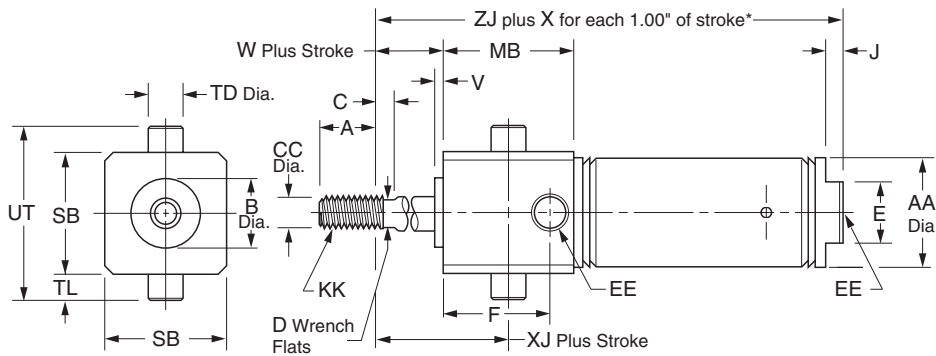
Bore size	J	KK	MB	SB	TD	TL	UT	V	W	X	XJ	SR ZJ	SRM ZJ
7/16"	0.19	#10-32 UNF	0.88	0.75	0.374	0.25	1.25	0.062	0	0.94**	0.31	1.94	–
3/4"	0.19	5/16-24 UNF	1.12	1.00	0.500	0.38	1.75	0.093	0.34	1.69	0.69	2.66	2.91
1-1/16"	0.25	7/16-20 UNF	1.41	1.25	0.500	0.38	2.00	0.093	0.47	1.81	1.09	3.38	3.63
1-1/2"			1.88	1.75	0.500	0.38	2.50	0.125	0.38	2.00	1.31	3.69	3.94

\* To determine lengths for half inch stroke increments, determine length for next highest whole number stroke and subtract one half inch.

\*\* For each 0.50" of stroke

Mounting Style TFR

Front trunnion mount, single acting, spring extend



Bore size	SR	SRM	Std. stroke (in)	Max. stroke (in)	SS rod std	A	AA	B	C	CC	D	E
3/4"	•	•	1, 2, 3, 4	6	✓	0.75	0.81	0.624	0.25	0.250	0.22	0
1-1/16"	•	•	1, 2, 3, 4	6	✓	0.75	1.12	0.750	0.25	0.312	0.25	0
1-1/2"	•	•	1, 2, 3, 4	6	✓	1.25	1.56	1.000	0.25	0.437	0.38	0.88

Bore size	F	EE	J	KK	MB	SB	TD	TL	UT	V	W	X	XJ	SR ZJ	SRM ZJ
3/4"	0.88	1/8 NPTF	–	1/4-28 UNF	1.12	1.00	0.500	0.38	1.75	0.093	0.34	2.69	0.69	2.56	2.81
1-1/16"	1.16	1/8 NPTF	–	5/16-24 UNF	1.41	1.25	0.500	0.38	2.00	0.093	0.47	2.81	1.09	3.12	3.37
1-1/2"	–	1/4 NPTF	0.25	7/16-20 UNF	1.88	1.75	0.500	0.38	2.50	0.125	0.38	3.00	1.31	3.69	3.94

\* To determine lengths for half inch stroke increments, determine length for next highest whole number stroke and subtract one half inch.



For inventory, lead times, and kit lookup, visit [www.pdnplu.com](http://www.pdnplu.com)

C28

Parker Hannifin Corporation  
Pneumatic Division  
Richland, Michigan  
[www.parker.com/pneumatics](http://www.parker.com/pneumatics)

**Air Reservoirs**

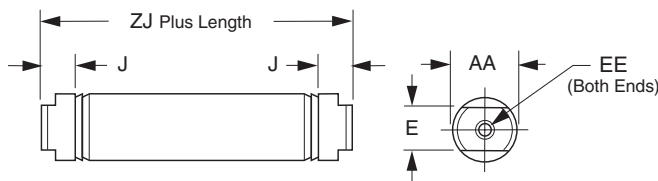
Air Reservoirs installed can significantly reduce the pulsation of a system. In addition air reservoirs can be used as a means to store energy. Caution should always be used when storing energy. Air reservoirs if installed in the correct location and sized correctly can temporarily increase the flow of an actuator or cylinder.

As always never exceed the rated pressure of the cylinder.

**Ordering information**

<p><b>.75</b></p> <table border="1" style="width: 100%;"> <tr><th colspan="2">Bore Size*</th></tr> <tr><td>.75</td><td>3/4"</td></tr> <tr><td>1.06</td><td>1-1/16"</td></tr> <tr><td>1.50</td><td>1-1/2"</td></tr> <tr><td>2.00</td><td>2"</td></tr> <tr><td>2.50</td><td>2-1/2"</td></tr> <tr><td>3.00</td><td>3"</td></tr> </table>	Bore Size*		.75	3/4"	1.06	1-1/16"	1.50	1-1/2"	2.00	2"	2.50	2-1/2"	3.00	3"	<p><b>AR</b></p> <table border="1" style="width: 100%;"> <tr><th colspan="2">Mounting</th></tr> <tr><td>AR</td><td>Air Reservoir</td></tr> </table>	Mounting		AR	Air Reservoir	<p><b>SR</b></p>	<p><b>2.00</b></p> <table border="1" style="width: 100%;"> <tr><th>Length</th></tr> <tr><td>Specify in inches. See table below.</td></tr> </table>	Length	Specify in inches. See table below.
Bore Size*																							
.75	3/4"																						
1.06	1-1/16"																						
1.50	1-1/2"																						
2.00	2"																						
2.50	2-1/2"																						
3.00	3"																						
Mounting																							
AR	Air Reservoir																						
Length																							
Specify in inches. See table below.																							

Bore size	Standard lengths	Max. length	Volume (in <sup>3</sup> )
3/4"	1" increments to 4"	32"	0.39 plus 0.44 per inch length
1-1/16"	1" increments to 8"	32"	0.99 plus 0.89 per inch length
1-1/2"	1" increments to 16"	32"	1.91 plus 1.77 per inch length
2"	1" increments to 16"	32"	4.22 plus 3.14 per inch length
2-1/2"	1" increments to 16"	32"	7.04 plus 4.91 per inch length
3"	1" increments to 16"	32"	9.90 plus 7.07 per inch length



Bore size	AA	E	EE	J	ZJ
3/4"	0.813	0.625	1/8" NPTF	0.19	1.938
1-1/16"	1.125	0.88	1/8" NPTF	0.19	2.375
1-1/2"	1.56	0.88	1/8" NPTF	0.250	2.250
2"	2.08	1.25	1/4" NPTF	0.562	2.875
2-1/2"	2.62	1.75	1/4" NPTF	0.562	2.875
3"	3.16	2.00	3/8" NPTF	0.562	3.190

C

Round Body Pneumatic Cylinders

SR/SRM/SRD/SRDM Series

SRG/SRGM Series

SRX Series

P1A Series

P Series

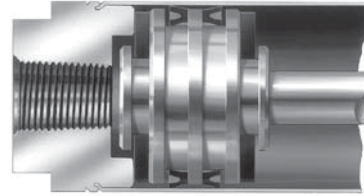


For inventory, lead time, and kit lookup, visit [www.pdnplu.com](http://www.pdnplu.com)

Options

Bumpers

Bumpers are available at extra cost except where noted as standard. Add the following dimensions to the overall cylinder length by bore.



SR Bumper Adder

Cylinder Type	SR Series Bore Size											
	5/16"	7/16"	9/16"	3/4"	7/8"	1-1/16"	1-1/4"	1-1/2"	1-3/4"	2"	2-1/2"	3"
Spring Return	*	0.062"	0.062"	0.125"	*	0.125"	*	**	*	0.125"	N/A	N/A
Spring Extend	*	0.125"	0.062"	0.125"	*	0.125"	*	**	*	0.125"	N/A	N/A
Double Acting	*	0.188"	0.125"	**	*	0.125"	*	0.125"	*	0.250"	0.250"	N/A
K-type	N/A	0.250"	0.125"	**	*	0.500"	*	0.125"	*	0.250"	0.250"	N/A

\* Bumpers are furnished as standard and do not affect overall length.  
\*\* Bumpers do not affect overall length.

SRM Bumper Adder

Cylinder Type	SRM Series Bore Size							
	9/16"	3/4"	1-1/16"	1-1/4"	1-1/2"	1-3/4"	2"	2-1/2"
Spring Return	0.062"	0.125"	0.125"	0.125"	0.125"	*	0.125"	N/A
Spring Extend	0.062"	0.125"	0.125"	0.125"	0.125"	*	0.125"	N/A
Double Acting	0.125"	0.250"	0.250"	0.250"	0.250"	*	0.250"	0.250"
K-type	0.125"	0.312"	0.250"	0.250"	0.250"	*	0.250"	0.250"

Fluorocarbon Seals

Available on all bore sizes at extra cost. Not available on SRM or SRDM series.

Rod Wiper

SR/SRM Series cylinders can be fitted with a rod wiper that is specially designed to prevent contaminants from clinging to the piston rod and damaging the piston rod seal. Available in 3/4", 1-1/16", and 1-1/2" bores, the piston rod wiper can be added to the SR/SRM and SRD/SRDM series.

Stainless Steel Piston Rods

Corrosion resistant stainless steel is the standard piston rod material for all bore sizes up to and including 1-1/2 inch bore at no additional cost. The only exception to the stainless steel standard is when a hollow rod, KDXH option is specified. Stainless steel is also the standard material on block, trunnion, hex/non-rotating and KDX mounts. Stainless steel is available on other sizes for an additional charge.

Round Body Pneumatic Cylinders  
 SR/SRM/SRD/SRDM Series  
 SRG/SRGM Series  
 SRX Series  
 P1A Series  
 P Series



For inventory, lead times, and kit lookup, visit [www.pdnplu.com](http://www.pdnplu.com)

## Options

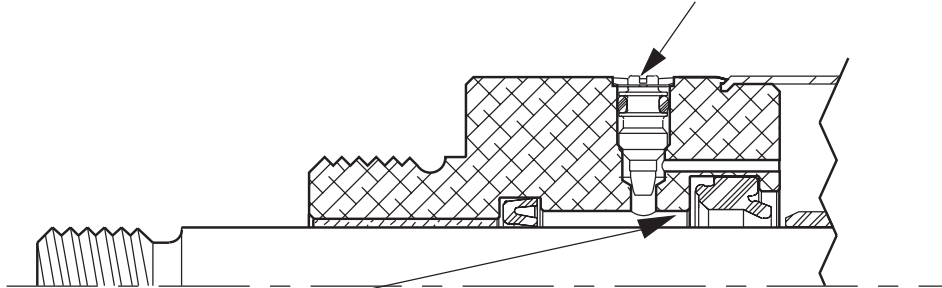
## Round Body Pneumatic Cylinders SR Series, Stainless Steel

### Adjustable Cushion Option

Cushions can be selected on nine bore sizes, ranging from 0.75" bore to 3.0" bore with mounting styles D, front nose mount, and DXP, rear pivot mount. Adjustable cushions are not available with double rod SR Series cylinders.

### Cushion Adjusting Needle Valves

The fine-thread cushion needle valves make precise adjustment quick and easy. The needle valve is fully captured to allow for safe cushion adjustment while cylinder is pressurized. The brass needle valves are corrosion resistant. The standard position for needle valve adjustments is position 1, 90° from the port. See port location table for SR Series Cylinders.



### Check Seal Cushion

The "Check Seal" system offers excellent cushioning efficiency and long cushion seal life. This seal is specifically designed for cushion applications and has a long proven history in our products. Extensive side by side testing of the check seal in SR Series cylinders significantly outlasted and outperformed competitors' o-ring shaped seals.

The Check Seal's unique geometry exhibits the dynamic sealing capabilities of a lipseal. As the cushion sleeve enters the Check Seal at the end of stroke, the Check Seal blocks the air from exhausting directly through the port and forces

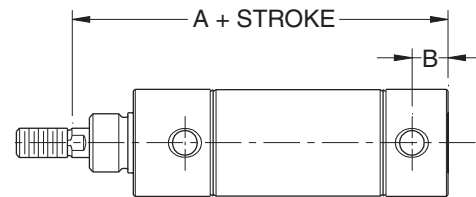
the air through the adjustable needle valve orifice. The exhaust airflow is precisely metered to control the desired rate of deceleration of the cylinder piston.

During stroke reversal, the check valve action of the Check Seal induces a fast out-of-cushion response. The Check Seal floats forward in the retainer groove as the cushion sleeve exits the Cushion Seal, thereby creating a path for maximum air flow around the Check Seal to access the piston face. The quick response of the Check Seal design yields faster cycle times and increased productivity.

### Critical Mounting Dimensions for SR Series and SRM Cylinders with Adjustable Cushions

In most cases, cylinder mounting dimensions are not affected when cushions are specified. Standard catalog dimensions apply when cushions are specified at either end of a DXP mount and when specified at the head end only of a D mount. **The only exception to standard catalog dimensions is when a cushion is specified on the cap end or both ends of a D mount.** Please consult Table A for the critical mounting dimensions on D mount SR and SRM cylinders with cushions both ends or cushions cap end only.

Table B shows the cushion lengths for SR and SRM cylinders.



D Mount

**Table A:**  
Critical Mounting Dimensions for D Mount SR and SRM Cylinders with Cushions Both Ends or Cushions Cap End Only.

Bore size	SR Dimensions		SRM Dimensions	
	A + Stroke	B	A + Stroke	B
.75	3.40	0.28	3.40	0.28
.88	3.25	0.28	N/A	N/A
1.06	3.49	0.28	3.65	0.28
1.25	4.31	0.38	4.34	0.38
1.50	4.12	0.31	4.37	0.31
1.75	5.25	0.42	5.25	0.42
2.00	5.06	0.47	5.34	0.47
2.50	5.06	0.47	5.06	0.47
3.00	5.69	0.53	N/A	N/A

**Table B:**  
Cushion Lengths for SR and SRM Cylinders.

Bore size	Cushion Lengths	
	Head	Cap
.75	0.750	0.625
.88	0.750	0.625
1.06	0.750	0.625
1.25	0.750	0.625
1.50	0.750	0.625
1.75	0.875	0.625
2.00	0.875	0.750
2.50	0.875	0.750
3.00	0.875	1.000



Round Body  
Pneumatic Cylinders

SR/SRM/SRD/SRDM  
Series

SRG/SRGM  
Series

SRX  
Series

P1A  
Series

P  
Series



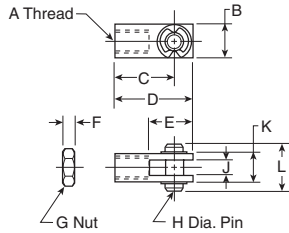
For inventory, lead time, and kit lookup, visit [www.pdnplu.com](http://www.pdnplu.com)

C31

**Parker Hannifin Corporation**  
Pneumatic Division  
Richland, Michigan  
[www.parker.com/pneumatics](http://www.parker.com/pneumatics)

**Piston Rod Clevis**

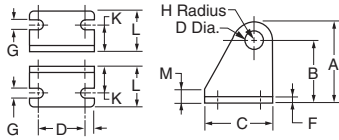
Assembly includes pin and (2) retainer rings and (1) jam nut.



Bore size	A	B	C	D	E	F	G	H	J	K	L	Part number
5/16	#5-40	.31	.44	.56	.38	.11	#5-40	.12	.13	.31	.50	L071300025
7/16, 9/16	#10-32	.38	.75	.94	.56	.12	#10-32	.19	.19	.38	.56	L071300100 L077130100*
3/4, 7/8	1/4-28	.50	.94	1.19	.68	.16	1/4-28	.25	.25	.50	.69	L071300200 L077130200*
1-1/16	5/16-24	.50	.94	1.19	.68	.19	5/16-24	.25	.25	.50	.69	L071300300 L077130300*
1-1/4, 1-1/2	7/16-20	.75	1.31	1.69	.94	.25	7/16-20	.38	.38	.75	1.03	L071300400 L077130400*
1-3/4, 2, 2-1/2	1/2-20	.75	1.31	1.69	.94	.31	1/2-20	.38	.38	.75	1.03	L071300500 L077130500*
3	5/8-18	1.00	2.25	2.75	1.50	.38	5/8-18	.50	.50	1.00	1.38	L071300600

\* Stainless Steel for use with SRD/SRDM cylinders.

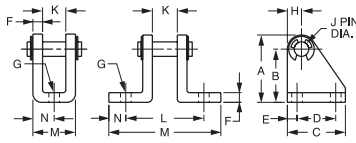
**Pivot Brackets**



Bore size	A	B	C	D	E	F	G	H	J	K	L	M	Part number
7/16	.76	.56	.75	.50	.12	.06	.19	.20	.160	.28	.50	.12	L071310100
3/4, 7/8, 1-1/16	1.19	.88	1.12	.75	.19	.12	.27	.31	.255	.44	.81	.25	L071310200
1-1/2	1.75	1.38	1.50	1.00	.25	.12	.27	.38	.380	.62	1.00	.25	L071310300

**Pivot Bracket Assembly**

Assembly includes pin and (2) retainer rings.

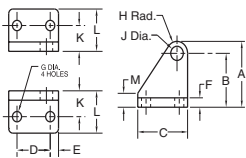


Bore size	A	B	C	D	E	F	G	H	J	K	L	M	N	Part number	
5/16	.53	.40	.62	.38	.12	.04	16	.12	.12	.26	-	.36	.18	L071320025	
7/16, 9/16	.76	.56	.75	.50	.12	.06	.19	.19	.156	.34	.91	1.34	.22	L071320100 L077150100*	
3/4, 7/8, 1-1/16	1.18	.88	1.12	.75	.19	.12	.27	.30	.250	.38	1.25	2.00	.38	L071320200 L077150200*	
1-1/4	1.18	.88	1.12	.75	.19	.12	.27	.30	.250	.50	1.38	2.14	.38	L071320300	
1-1/2, 1-3/4	1.75	1.38	1.50	1.00	.25	.25	.27	.37	.375	.62	2.00	2.88	.44	L071320400 L077150400*	
5/16" bore only	2, 2-1/2	1.75	1.38	1.50	1.00	.25	.25	.27	.375	.75	2.12	3.00	.44	L071320500 L077150500*	
	3	2.25	1.75	1.75	1.25	.25	.25	.27	50	.50	.88	2.62	3.88	.62	L071320600

\* Stainless steel for use with SRD/SRDM cylinders.

**SR Series Trunnion Brackets**

Select brackets for SR series trunnion mount cylinders from the table below. (Note: trunnion brackets are ordered as a separate item from the cylinder.)



Bore size	A	B	C	D	E	F	G	H	J	K	L	M	Part number
7/16	1.75	1.38	1.50	1	.25	.25	.27	.38	.375	.69	1.12	.37	L076600100
3/4, 1-1/16, 1-1/2	1.75	1.38	1.50	1	.25	.25	.27	.38	.500	.69	1.12	.37	L076600200

Most popular.



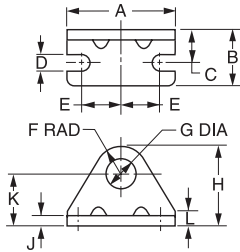
For inventory, lead times, and kit lookup, visit [www.pdnplu.com](http://www.pdnplu.com)

C32

**Parker Hannifin Corporation**  
Pneumatic Division  
Richland, Michigan  
[www.parker.com/pneumatics](http://www.parker.com/pneumatics)



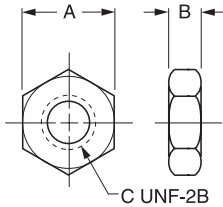
**Foot Brackets**



Bore size	A	B	C	D	E	F	G	H	J	K	L	Part number
5/16	1.00	.37	.25	.13	.37	.31	.25	.75	.06	.44	.12	L073790016
5/16	1.00	.37	.25	.13	.37	.31	.38	.75	.06	.44	.12	L073790023
7/16	1.38	.62	.31	.19	.50	.31	.38	.88	.07	.56	.12	L073790024
7/16, 9/16	1.38	.62	.38	.19	.50	.38	.44	.94	.09	.56	.12	L073790028 L077160028*
3/4	1.62	.75	.44	.19	.62	.41	.50	1.09	.10	.69	.19	L073790032
3/4, 7/8, 1-1/16	1.88	1.00	.56	.27	.75	.56	.63	1.38	.12	.81	.25	L073790040 L077160040*
1-1/4, 1-1/2	2.50	1.50	.75	.27	.94	.75	.75	1.75	.12	1.00	.38	L073790048 L077160048*
1-3/4	3.00	1.50	.87	.35	1.12	.91	1.03	2.16	.19	1.25	.50	L073790102
2	3.12	1.62	1.00	.34	1.12	1.00	1.38	2.50	.25	1.50	.62	L073790124 L077160124*
2-1/2	3.75	1.62	1.00	.35	1.44	1.25	1.51	3.00	.25	1.75	.75	L073790132
3	4.37	1.62	1.00	.35	1.75	1.25	1.64	3.14	.25	1.89	.89	L073790140

\* Stainless Steel for use with SRD/SRDM cylinders.

**Mounting Nut**



Bore size	A	B	C	Part number
5/16	.44	.16	1/4-28	L073800200
5/16, 7/16	.56	.22	3/8-24	L073800400
7/16, 9/16	.69	.25	7/16-20	L073800500 L077170500*
3/4	.75	.31	1/2-20	L073800600
3/4, 7/8, 1-1/16	.94	.38	5/8-18	L073800800 L077170800*
1-1/4, 1-1/2	1.12	.42	3/4-16	L073800900
1-1/4, 1-1/2	1.12	.72	3/4-16	L077170900*
1-3/4	1.50	.55	1-14	L073801100
2	1.88	.50	1-1/4-12	L073801200 L077171200*
2-1/2	2.06	.78	1-3/8-12	L073801400
3	2.25	.84	1-1/2-12	L073801500

\* Stainless Steel for use with SRD/SRDM cylinders.

Most popular.



For inventory, lead time, and kit lookup, visit [www.pdnplu.com](http://www.pdnplu.com)



Round Body  
 Pneumatic Cylinders

SR/SRM/SRD/SRDM  
 Series

SRG/SRGM  
 Series

SRX  
 Series

P1A  
 Series

P  
 Series

**Features**

**SRG & SRGM Series**

- 304 stainless steel cylinder body, non repairable construction
- 303 Stainless steel heads and caps
- 303 Stainless steel piston rod standard on all bore sizes
- Urethane rod wiper standard
- Available with bumpers and magnetic pistons
- Double acting models only
- Available with Nose, Foot and Pivot Mounts
- Corrosion resistant, reinforced plastic pivot bushing



**Operating information**

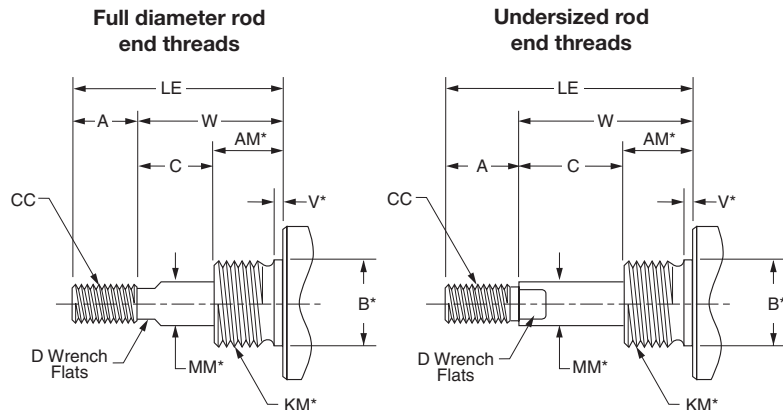
Operating pressure: 250 PSIG (17 bar) for SRG and SRGM  
 Temperature range: -10°F to 165°F (-23°C to 74°C) for SRG  
 14°F to 140°F (-10°C to 60°C) for SRGM  
 Filtration requirements: 40 micron, dry filtered air

**Ordering information**

<b>1.06</b>	<b>D</b>	<b>SRG</b>	<b>B</b>	<b>V</b>	<b>Y</b>	<b>2.00</b>
<b>Bore Size</b>	<b>Series</b>	<b>Seals</b>	<b>Stroke</b>	<b>Non-Standard Piston Rod</b>	<b>Non-Standard Rod</b>	<b>Special</b>
.75 3/4"	SRG Stainless caps	Blank Standard seals	Specify in inches	Use "3" only when special piston rod end is required. Specify CC, LE and A Dimensions (See below.)	Stainless steel piston rod 303 stainless steel is standard on all bore sizes	Use "S" only if special modifications are required, except piston rod end.
1.06 1-1/16"	SRGM Stainless caps and magnetic piston	V Fluorocarbon seals*				
1.50 1-1/2"	<b>Mounting</b>	Urethane rod wiper is standard	<b>Piston</b>			
2.00 2"	D, DXP	* Fluorocarbon seals not available on SRGM series.	Blank No bumpers			
2.50 2-1/2"			B With bumpers			

**Non-Standard Rods**

For non-standard rod dimensions, or undersized rod end threads, put a "3" in model number and describe the rod using the letters shown in the drawing. Specify CC, LE and A dimensions. LE is measured in retracted position.



\* Requires an S designation in model number.

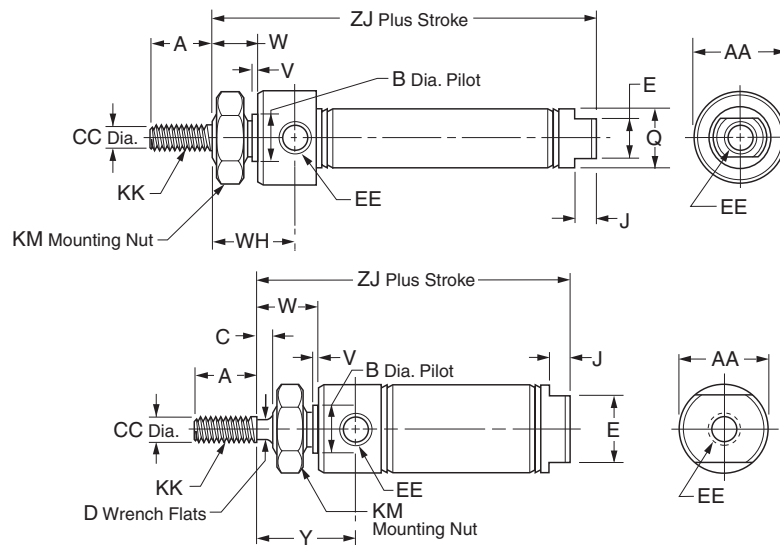
Round Body Pneumatic Cylinders  
 SR/SRM/SRD/SRDM Series  
 SRG/SRGM Series  
 SRX Series  
 P1A Series  
 P Series



For inventory, lead times, and kit lookup, visit [www.pdnplu.com](http://www.pdnplu.com)

**Mounting Style D**

Nose mount, double acting



Bore sizes †  
 3/4" \*

Bore sizes †  
 1-1/16" \*  
 1-1/2" \*  
 2" \*  
 2-1/2" \*

\* No mounting nuts  
 † Mounting nuts sold separately for all series SRG

Bore size	Std. stroke (in)	Max. stroke (in)	SS rod std	A	AA	B	C	CC	D
3/4"	1/2, 1, 2, 2-1/2, 3, 4, 5, 6, 8, 10	12	✓	0.50	0.86	0.624	-	0.250	-
1-1/16"	1/2, 1, 1-1/2, 2, 2-1/2, 3, 4, 5, 6, 8, 10, 12	12	✓	0.50	1.12	0.624	0.12	0.312	0.25
1-1/2"	1/2, 1, 2, 3, 4, 5, 6, 8, 10, 12	12	✓	0.75	1.56	0.749	0.25	0.437	0.38
2"	-	12	✓	0.88	2.08	1.374	0.38	0.625	0.50
2-1/2"	-	12	✓	0.88	2.62	1.500	0.38	0.625	1/2

Bore size	E	EE	J	KK	KM	Q	V	W	WH	Y	ZJ	
											SRG	SRGM
3/4"	0.62	1/8 NPTF	0.19	1/4-28 UNF	5/8-18	0.81	0.09	0.50	0.97	-	2.97	2.97
1-1/16"	0.88	1/8 NPTF	0.19	5/16-24 UNF	5/8-18	-	0.09	0.62	-	1.19	3.25	3.41
1-1/2"	0.88	1/8 NPTF	0.25	7/16-20 UNF	3/4-16	-	0.09	0.88	-	1.50	3.69	3.94
2"	1.25	1/4 NPTF	0.31	1/2-20 UNF	1-1/4-12	-	0.12	1.19	-	1.84	4.69	4.97
2-1/2"	1.75	1/4 NPTF	0.31	1/2-20 UNF	1-3/8-12	-	0.13	1.19	-	1.84	4.69	4.69

† Mounting nuts sold separately for all series SRG

**C**

**Round Body Pneumatic Cylinders**

**SR/SRM/SRD/SRDM Series**

**SRG/SRGM Series**

**SRX Series**

**P1A Series**

**P Series**



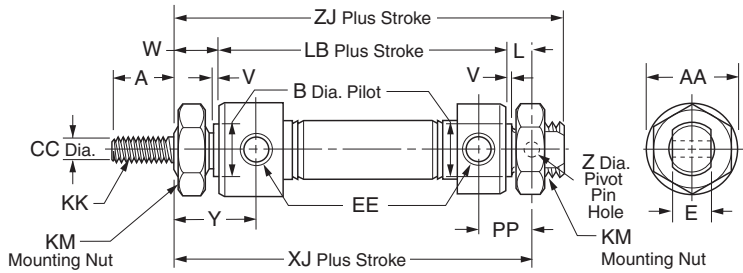
For inventory, lead time, and kit lookup, visit [www.pdnplu.com](http://www.pdnplu.com)

C35

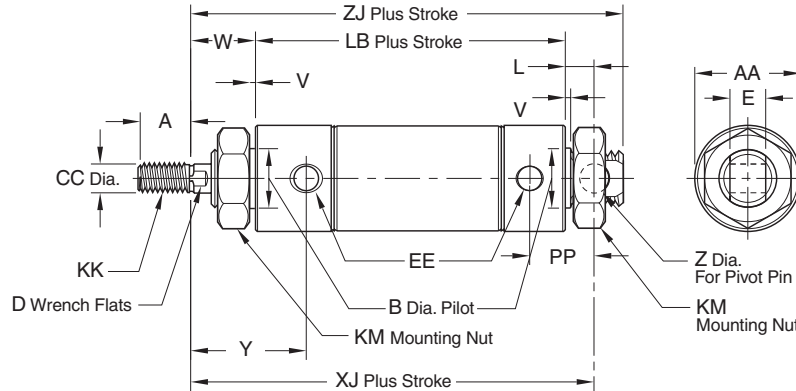
**Parker Hannifin Corporation**  
 Pneumatic Division  
 Richland, Michigan  
[www.parker.com/pneumatics](http://www.parker.com/pneumatics)

**Style DXP**

Pivot & nose mount, double acting, no pivot pin



Bore sizes †  
3/4" \*



Bore sizes †  
1-1/16" \*  
1-1/2" \*  
2" \*  
2-1/2" \*

\* No mounting nuts  
† Mounting nuts sold separately for all series SRG

Bore size	Std. stroke (in)	Max. stroke (in)	SS rod std	A	AA	B	CC	D	E	EE
3/4"	1, 2, 3, 4, 5, 6, 8, 10	32	✓	0.50	0.86	0.624	0.250	–	0.38	1/8 NPTF
1-1/16"	1/2, 1, 1-1/2, 2, 2-1/2, 3, 4, 5, 6, 8, 10, 12	32	✓	0.50	1.12	0.624	0.312	0.25	0.38	1/8 NPTF
1-1/2"	–	32	✓	0.75	1.56	0.749	0.437	0.38	0.62	1/8 NPTF
2"	–	32	✓	0.88	2.08	1.374	0.625	0.50	0.75	1/4 NPTF
2-1/2"	–	32	✓	0.88	2.62	1.500	0.625	1/2	0.75	1/4 NPTF

Bore size	XJ							SRG		SRGM		ZJ	
	KK	KM	L	LB	PP	V	W	SRG	SRGM	Y	Z	SRG	SRGM
3/4"	1/4-28 UNF	5/8-18	0.34	2.91	0.62	0.09	0.50	3.75	3.75	0.97	0.251	4.03	4.03
1-1/16"	5/16-24 UNF	5/8-18	0.34	–	0.62	0.09	0.62	3.84	–	1.19	0.251	4.12	4.28
1-1/2"	7/16-20 UNF	3/4-16	0.50	–	0.81	0.09	0.88	4.38	4.63	1.50	0.376	4.75	5.00
2"	1/2-20 UNF	1-1/4-12	0.56	–	1.03	0.12	1.19	5.62	5.91	–	0.376	6.06	6.34
2-1/2"	1/2-20 UNF	1-3/8-12	0.56	–	1.03	0.13	1.19	5.62	5.62	1.84	0.376	6.06	6.06

† Mounting nuts sold separately for all series SRG

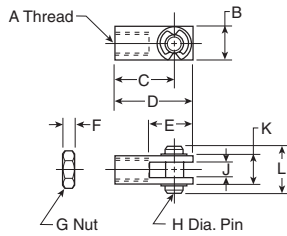
Round Body Pneumatic Cylinders  
 SR/SRM/SRD/SRDM Series  
 SRG/SRGM Series  
 SRX Series  
 P1A Series  
 P Series



For inventory, lead times, and kit lookup, visit [www.pdnplu.com](http://www.pdnplu.com)

**Piston Rod Clevis**

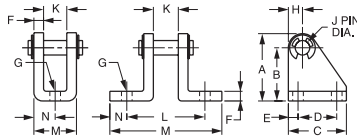
Assembly includes pin and (2) retainer rings and (1) jam nut.



Bore size	A	B	C	D	E	F	G	H	J	K	L	Part number
3/4	1/4-28	.50	.94	1.19	.68	.16	1/4-28	.25	.25	.50	.69	L077130200
1-1/16	5/16-24	.50	.94	1.19	.68	.19	5/16-24	.25	.25	.50	.69	L077130300
1-1/2	7/16-20	.75	1.31	1.69	.94	.25	7/16-20	.38	.38	.75	1.03	L077130400
2, 2-1/2	1/2-20	.75	1.31	1.69	.94	.31	1/2-20	.38	.38	.75	1.03	L077130500

**Pivot Bracket Assembly**

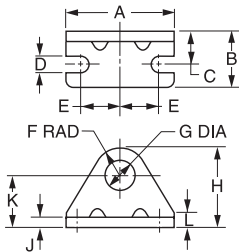
Assembly includes pin and (2) retainer rings.



Bore size	A	B	C	D	E	F	G	H	J	K	L	M	N	Part number
3/4, 1-1/16	1.18	.88	1.12	.75	.19	.12	.27	.30	.250	.38	1.25	2.00	.38	L077150200
1-1/2	1.75	1.38	1.50	1.00	.25	.25	.27	.37	.375	.62	2.00	2.88	.44	L077150400
2, 2-1/2	1.75	1.38	1.50	1.00	.25	.25	.27	.37	.375	.75	2.12	3.00	.44	L077150500

Stainless steel.

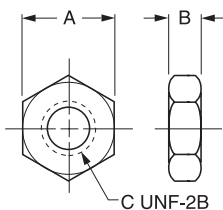
**Foot Brackets**



Bore size	A	B	C	D	E	F	G	H	J	K	L	Part number
3/4, 1-1/16	1.88	1.00	.56	.27	.75	.56	.63	1.38	.12	.81	.25	L077160040
1-1/2	2.50	1.50	.75	.27	.94	.75	.75	1.75	.12	1.00	.38	L077160048
2	3.12	1.62	1.00	.34	1.12	1.00	1.38	2.50	.25	1.50	.62	L077160124
2-1/2	3.75	1.62	1.00	.35	1.44	1.25	1.51	3.00	.25	1.75	.75	L077160132

Stainless steel.

**Mounting Nut**



Bore size	A	B	C	Part number
3/4, 1-1/16	.94	.38	5/8-18	L077170800
1-1/2	1.12	.42	3/4-16	L077170900
2	1.88	.50	1-1/4-12	L077171200
2-1/2	2.06	.78	1-3/8-12	L077171400

Stainless steel.

**Round Body Pneumatic Cylinders**  
**SR/SRM/SRD/SRDM Series**  
**SRG/SRGM Series**  
**SRX Series**  
**P1A Series**  
**P Series**



For inventory, lead time, and kit lookup, visit [www.pdnplu.com](http://www.pdnplu.com)

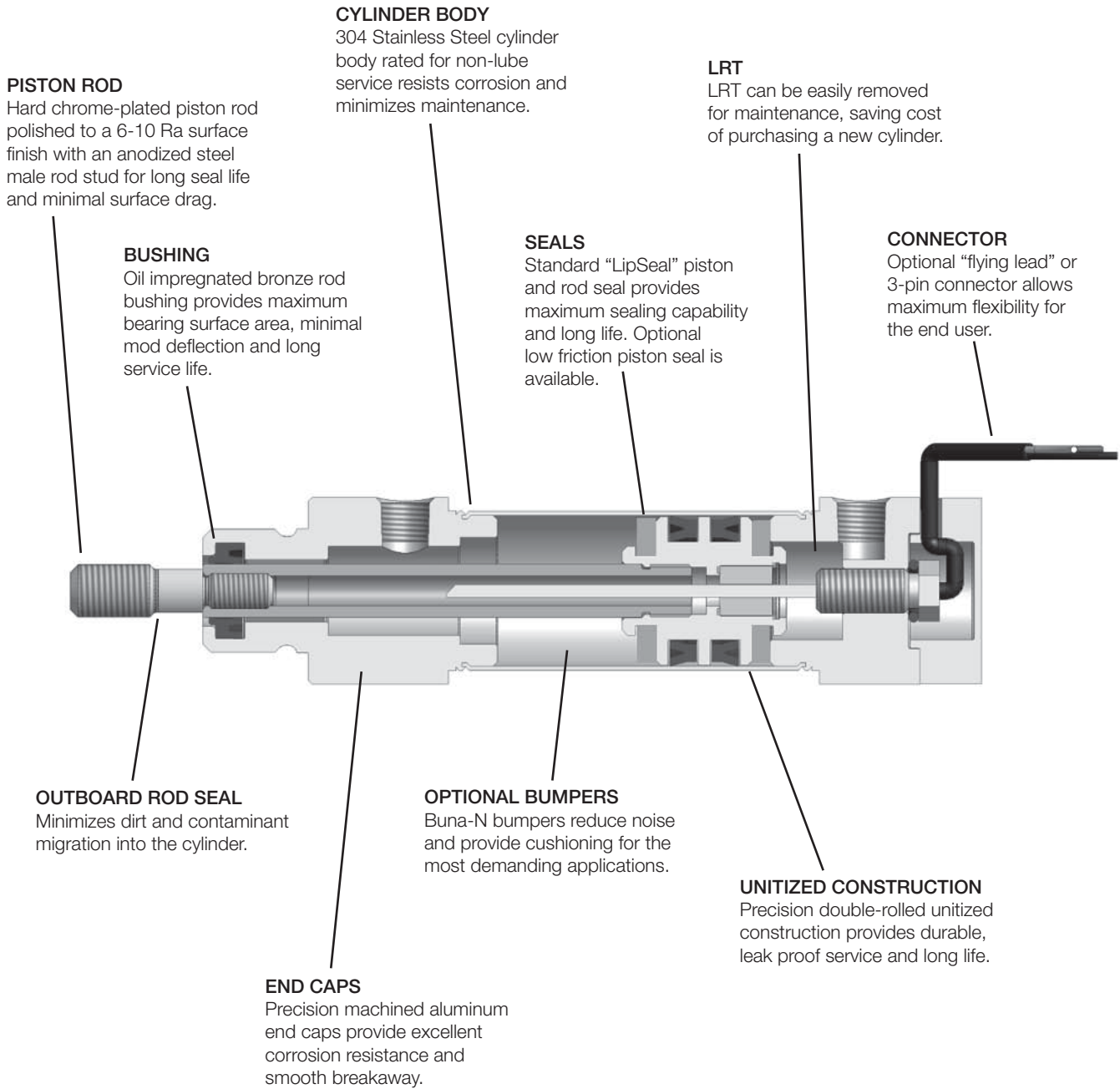
C37

**Parker Hannifin Corporation**  
 Pneumatic Division  
 Richland, Michigan  
[www.parker.com/pneumatics](http://www.parker.com/pneumatics)

**Features**

**SRX Series**

 Round Body Pneumatic Cylinders	SR/SRM/SRD/SRDM Series
	SRG/SRGM Series
SRX Series	
P1A Series	
P Series	



For inventory, lead times, and kit lookup, visit [www.pdnplu.com](http://www.pdnplu.com)

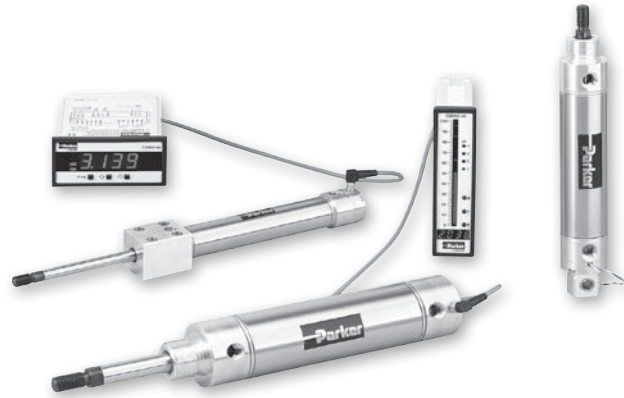
C38

**Parker Hannifin Corporation**  
 Pneumatic Division  
 Richland, Michigan  
[www.parker.com/pneumatics](http://www.parker.com/pneumatics)

## Features

- Continuous position feedback
- Bore sizes: 1-1/16" to 3"
- Signal input: 5 to 24 VDC
- Signal output (w/o controls): DC ratiometric voltage\*
- Signal output (w/controls): 0 to 10 VDC or 4 to 20 mA
- Strokes: Available in any practical stroke length up to 24"

\* Mega Ohm impedance interface device suggested for limiting sensor current if controller is not used.



## Operating information

Operating pressure:	150 PSIG (10.3 bar)
Temperature range:	40°F to 160°F (4.4°C to 71°C)
Filtration requirements:	40 micron, dry filtered air

## Ordering information

<b>1.50"</b>	<b>DXP</b>	<b>P</b>	<b>SRX</b>	<b>B</b>	<b>F</b>	<b>S</b>	<b>3</b>	<b>6.00"</b>
<b>Bore size</b>		<b>Connector style</b>		<b>Piston</b>		<b>Special</b>		<b>Stroke</b>
1.06"		P Plug		B Bumper*		S Special		Stroke in inches
1.50"		F Flying leads		Leave blank if not required.		Leave blank if special modification is not required.		
2.00"								
2.50"								
3.00"								
	<b>Mounting style</b>				<b>Seals</b>		<b>Non-standard rod dimension</b>	
	D Nose mount				F Low friction		3 Non-standard dimension	
	DXP Nose and pivot mount				Leave blank if not required.		Leave blank if special rod end dimension is not required.	
	BFD Front block mount							

\* Incorporating bumpers adds 1/4" of overall length to the cylinder.

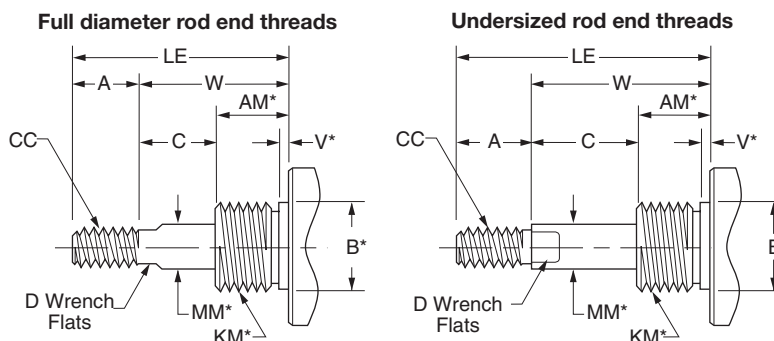
**Sensors**  
See section L for sensors.

**NOTE:** For non-standard / special rod ends, see below.

For ordering purposes, when special options or common modifications are requested, the factory will assign a sequential part number in place of the model number.

## Non-standard rods

For non-standard rod dimensions, or undersized rod end threads, put a "3" in model number and describe the rod using the letters shown in the drawing. It is necessary to specify only those dimensions that are non-standard. LE is measured in retracted position.



\* Requires an "S" designation in model number.

	Round Body Pneumatic Cylinders
	SR/SRM/SRD/SRDM Series
	SRG/SRGM Series
	SRX Series
	P1A Series
	P Series



For inventory, lead time, and kit lookup, visit [www.pdnplu.com](http://www.pdnplu.com)

## Specifications

### General Specifications

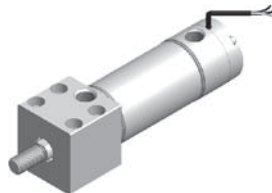
- Bore sizes: 1-1/16", 1-1/2", 2", 2-1/2", 3"
- Rod sizes: 0.38" – 0.75"
- Rod ends: Standard male
- Mounts:
  - Nose mount (D)
  - Front block mount (BFD)
  - Nose and pivot mount (DXP)
- Rated air pressure: 150 PSI Air
- Standard temperature: 40°F to 160°F
- Strokes: Available in any practical stroke length up to 24"
- Bumpers: Optional

## Round Body Pneumatic Cylinders SRX Series, Stainless Steel

### Available Mountings



Style D  
Nose Mount

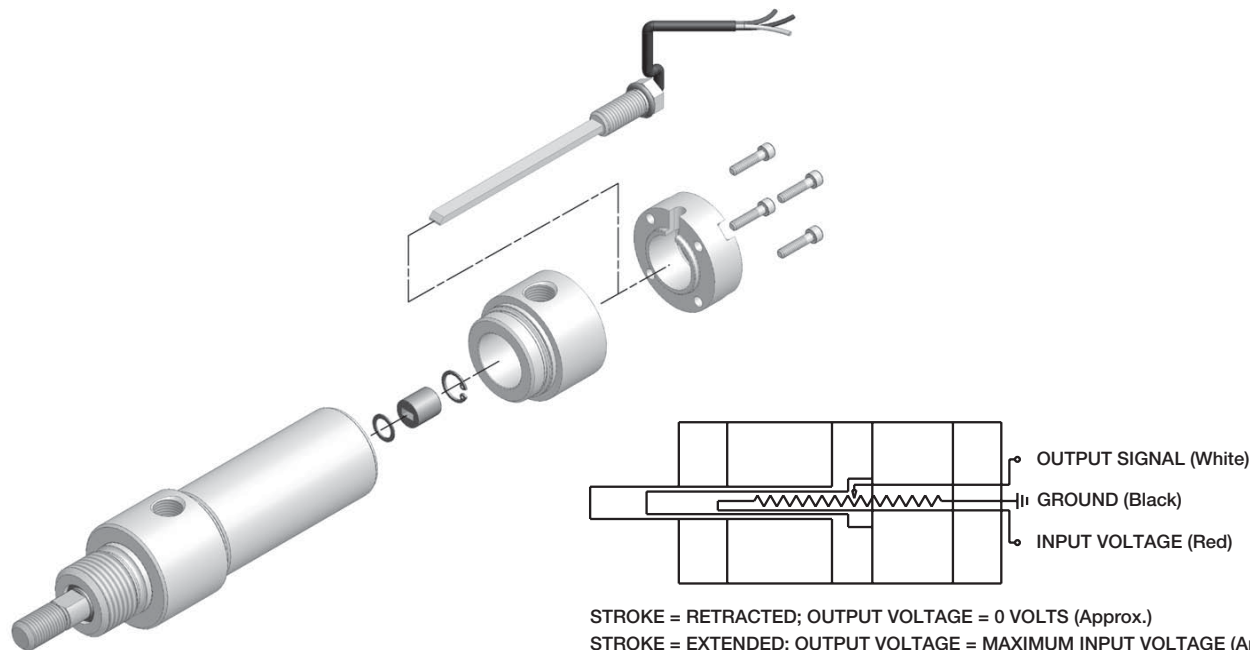


Style BFD  
Front Block Mount



Style DXP  
Nose and Pivot Mount

### Theory of Operation



The SRX Series Linear Resistive Transducer (LRT) is a position sensor that uses a resistive element, and wiper assembly, to provide a continuous analog output signal relative to the cylinders position. The LRT is a single element type linear potentiometer, with two independent elements mounted on either side of an anodized aluminum extrusion. The LRT operates as a voltage divider by creating a short between the wiper extrusion and the wiper assembly. The position of the wiper changes the resistive load proportionally to its position along the stroke length of the cylinder.

Supplying a 5 to 24VDC voltage energizes the LRT. As the cylinder travels through its range of stroke, the resistive load changes, thus causing a proportional voltage output change of the LRT. The output voltage, at the endpoint of cylinder stroke, is dictated by the input voltage applied across the device.

The probe is mounted into the cap end of the cylinder and inserted into the hollow piston rod assembly. When replacing the probe, care must be taken to align the wiper block with the profile of the LRT extrusion. Please review the above schematic and cutaway drawing for reference purposes.



For inventory, lead times, and kit lookup, visit [www.pdnplu.com](http://www.pdnplu.com)

C	Round Body Pneumatic Cylinders
	SR/SRM/SRD/SRDM Series
	SRG/SRGM Series
	SRX Series
	P1A Series
	P Series

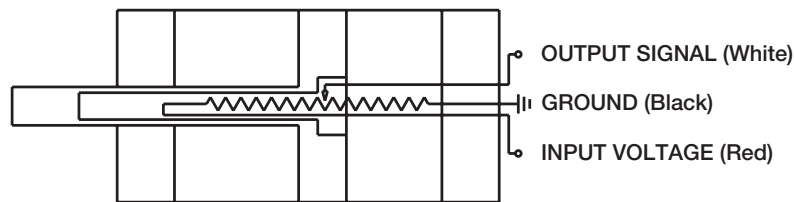


**MLRT**

Repeatability	±0.001" (interface electronics dependent)
Non Linearity	±1% of Full stroke (18" stroke max.)
Resolution	Infinite
Signal Input	5 to 24 VDC
Signal Output (w/o controls):	DC ratiometric voltage*
Signal Output (w/ controls):	0 to 10 VDC or 4 to 20 mA
Maximum Speed	50" per second
Rated Life of MLRT	500 Million inches of wiper travel
Pressure Rating	150 psi
Temperature Rating	40°F to 165°F
Resistance Rating	1,000 Ohms per inch ±20%
Connection Options	6" Flying leads or 3-pin nano connector

\* 1 Mega Ohm impedance interface device suggested for limiting sensor current if the controller is not used.

**MLRT Circuit Diagram**



STROKE = RETRACTED; OUTPUT VOLTAGE = 0 VOLTS (Approx.)  
 STROKE = EXTENDED; OUTPUT VOLTAGE = MAXIMUM INPUT VOLTAGE (Approx.)

**MLRT Replacement Kits**

For each MLRT replacement kit order, please specify the part number listed below along with the cylinder stroke length and quantity.

A Service Bulletin is included with each kit.

**MLRT with Flying Leads**

Part #**L07831**

Example: L07831, 6" Stroke, Qty. 1

**MLRT with Plug Connector**

Select part number from table

Example: L078320000, 4" Stroke, Qty. 1

Bore	Mount	Plug connector MLRT kit Part number
1-1/16"	D, BFD	L078320000
	DXP	L078320001
1-1/2"	D, BFD	L078320002
	DXP	L078320003
2"	D, BFD	L078320004
	DXP	L078320005
2-1/2"	D, BFD	L078320006
	DXP	L078320007
3"	D, BFD	L078320008
	DXP	L078320009

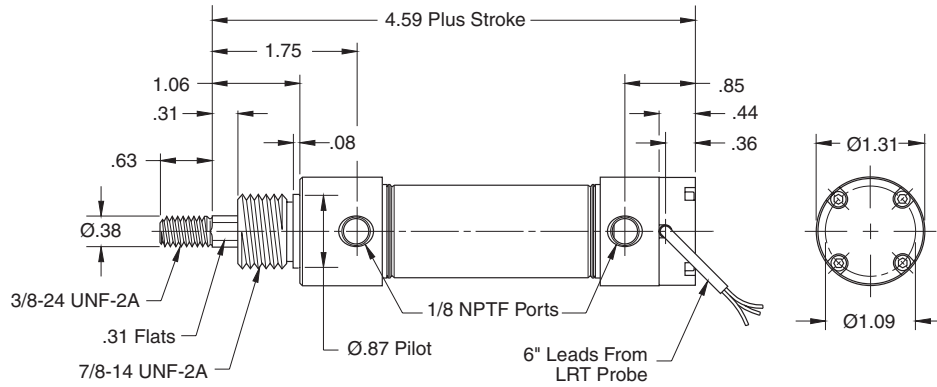
  
 Round Body  
 Pneumatic Cylinders  
 SR/SRM/SRD/SRDM  
 Series  
 SRG/SRGM  
 Series  
 SRX  
 Series  
 P1A  
 Series  
 P  
 Series



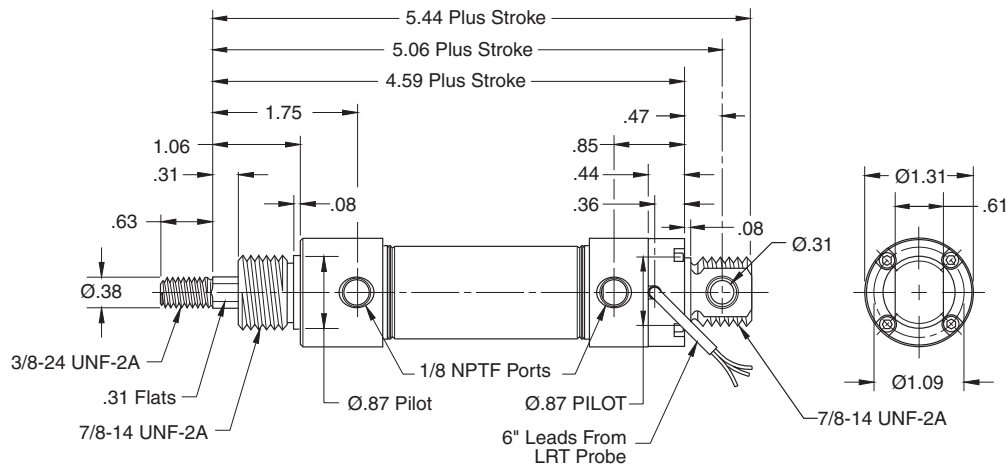
For inventory, lead time, and kit lookup, visit [www.pdnplu.com](http://www.pdnplu.com)

1-1/16" Bore Cylinders

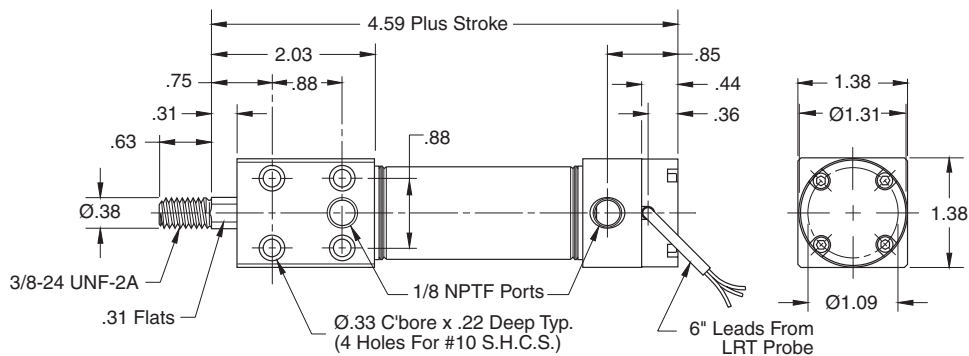
Style D



Style DXP



Style BFD



Round Body Pneumatic Cylinders
SR/SRM/SRD/SRDM Series
SRG/SRGM Series
SRX Series
P1A Series
P Series



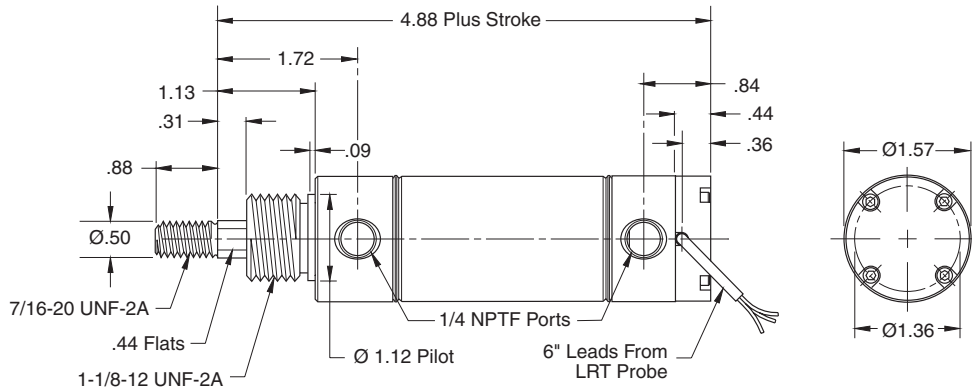
For inventory, lead times, and kit lookup, visit [www.pdnplu.com](http://www.pdnplu.com)

C42

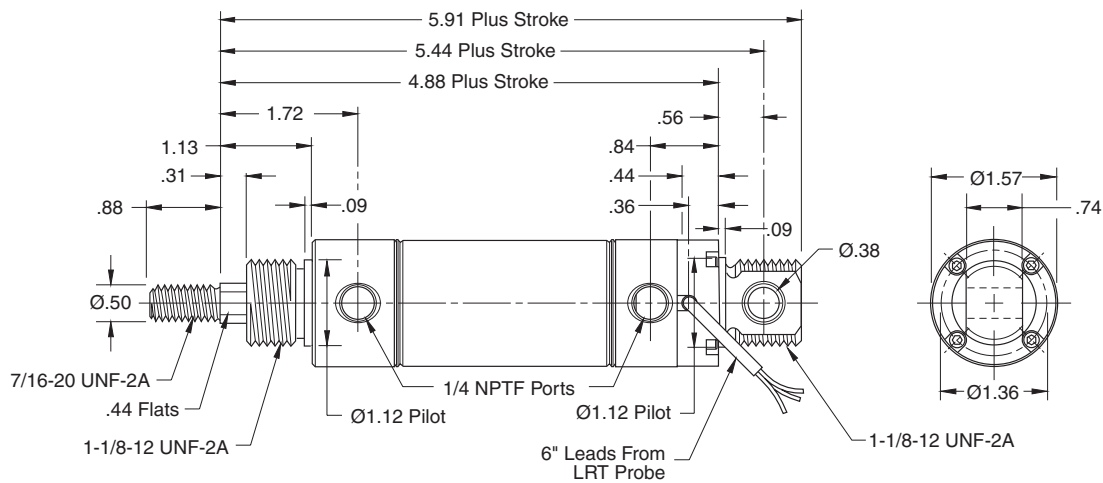
Parker Hannifin Corporation  
Pneumatic Division  
Richland, Michigan  
[www.parker.com/pneumatics](http://www.parker.com/pneumatics)

1-1/2" Bore Cylinders

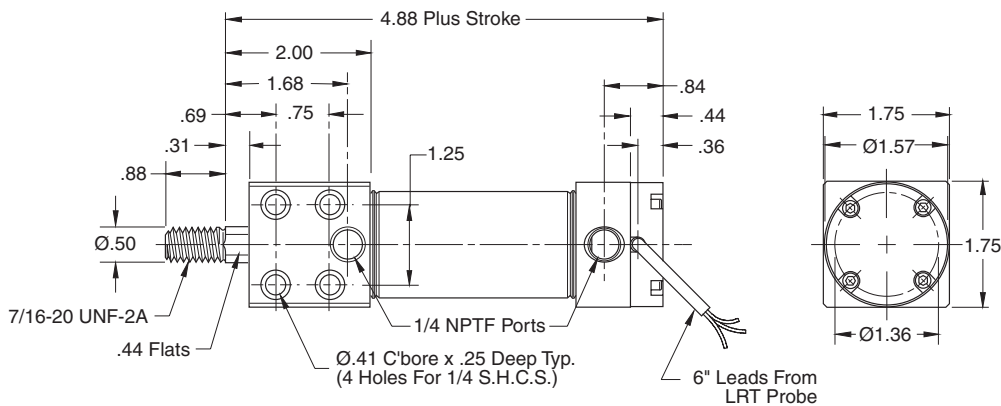
Style D



Style DXP



Style BFD



	<b>Round Body Pneumatic Cylinders</b>
<b>SR/SRM/SRD/SRDM Series</b>	<b>SRG/SRGM Series</b>
<b>SRX Series</b>	<b>P1A Series</b>
<b>P Series</b>	



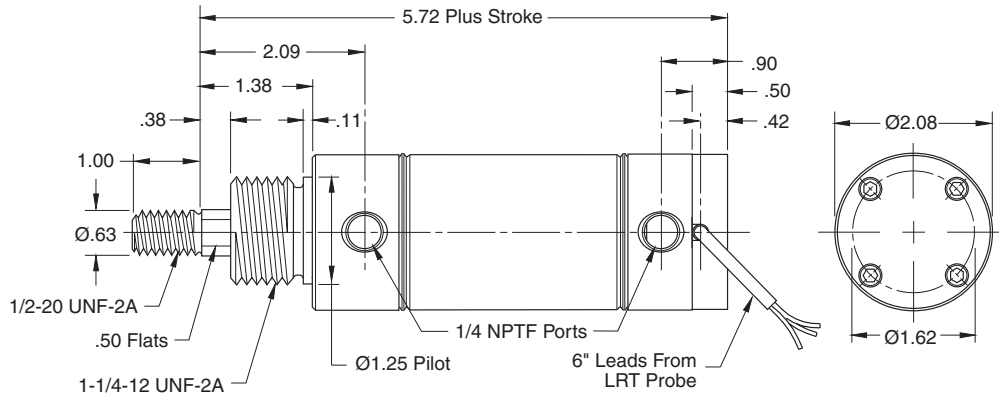
For inventory, lead time, and kit lookup, visit [www.pdnplu.com](http://www.pdnplu.com)

C43

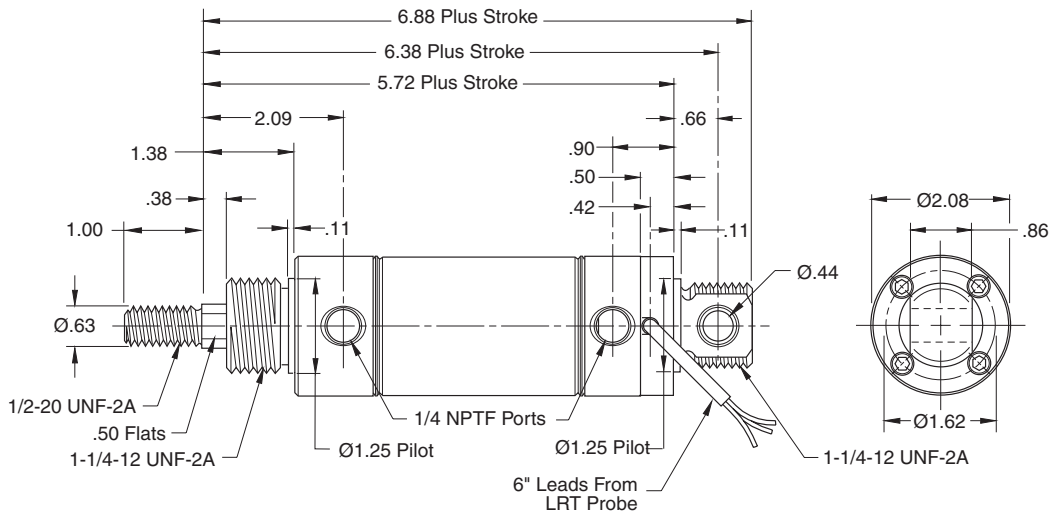
**Parker Hannifin Corporation**  
Pneumatic Division  
Richland, Michigan  
[www.parker.com/pneumatics](http://www.parker.com/pneumatics)

2" Bore Cylinders

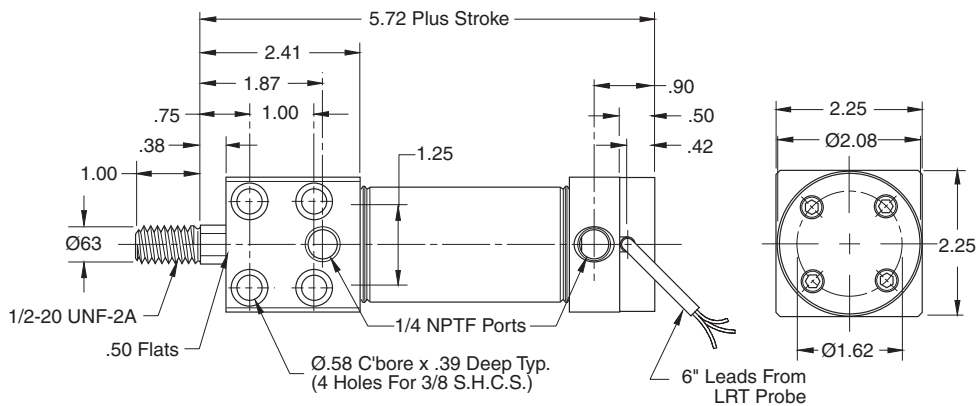
Style D



Style DXP



Style BFD



	Round Body Pneumatic Cylinders
	SR/SRM/SRD/SRDM Series
SRG/SRGM Series	SRX Series
P1A Series	P Series



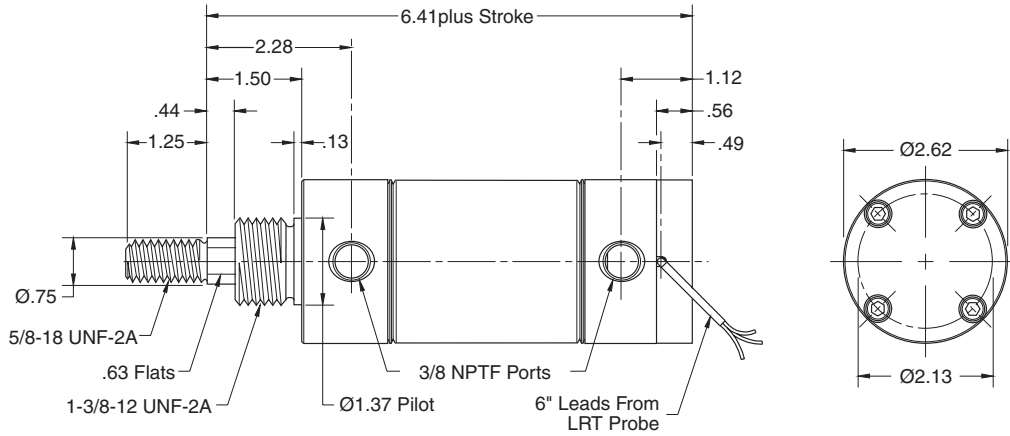
For inventory, lead times, and kit lookup, visit [www.pdnplu.com](http://www.pdnplu.com)

C44

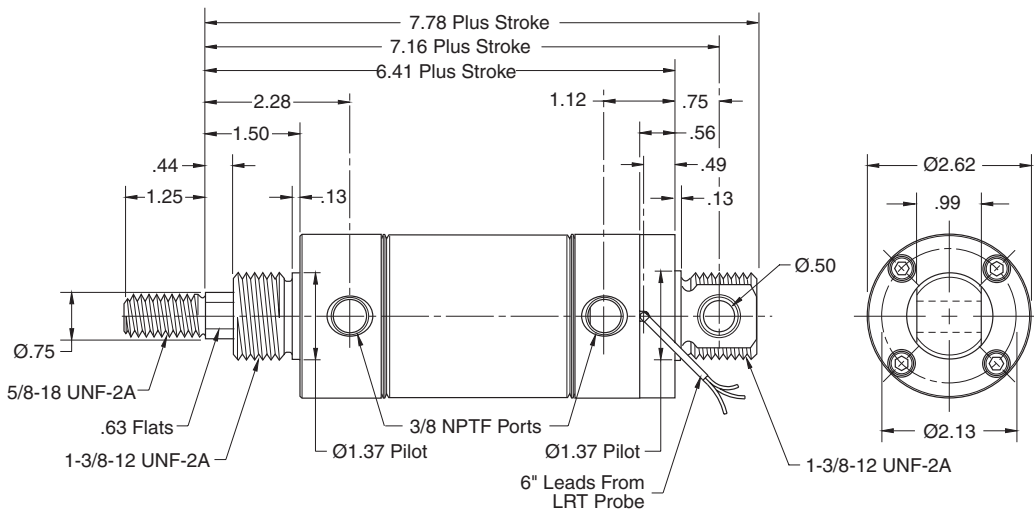
**Parker Hannifin Corporation**  
Pneumatic Division  
Richland, Michigan  
[www.parker.com/pneumatics](http://www.parker.com/pneumatics)

**2-1/2" Bore Cylinders**

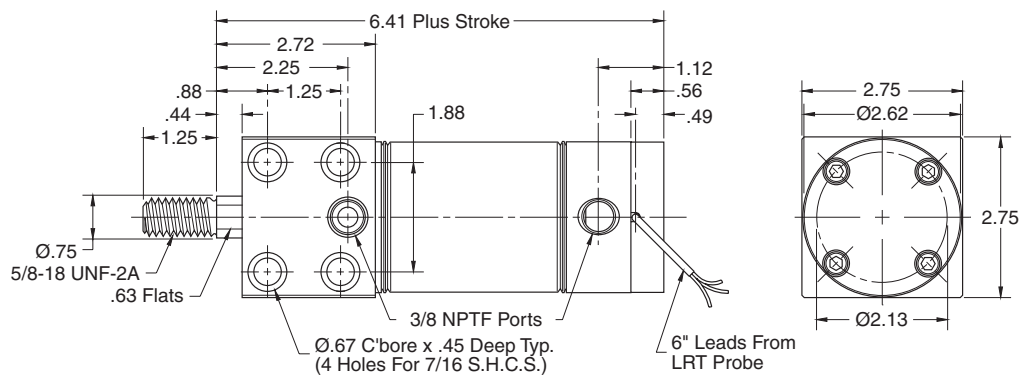
**Style D**



**Style DXP**



**Style BFD**



	Round Body Pneumatic Cylinders
	SR/SRM/SRD/SRDM Series
SRG/SRGM Series	SRX Series
P1A Series	P Series



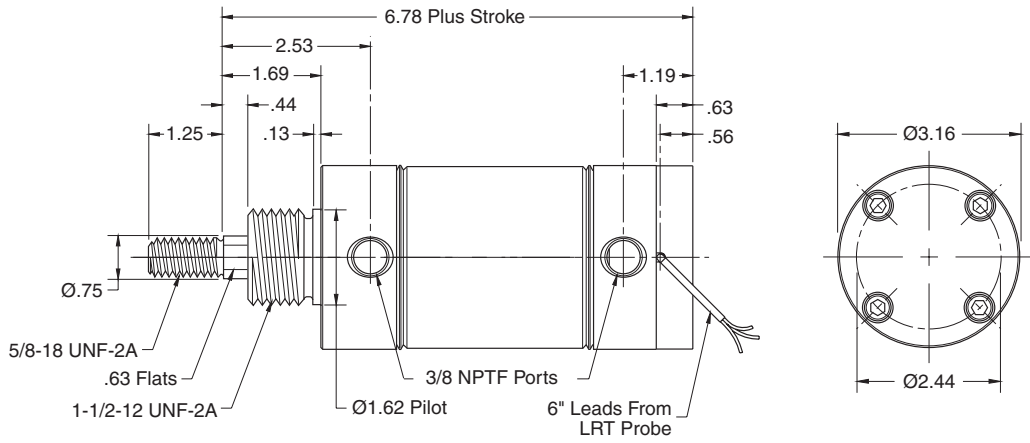
For inventory, lead time, and kit lookup, visit [www.pdnplu.com](http://www.pdnplu.com)

C45

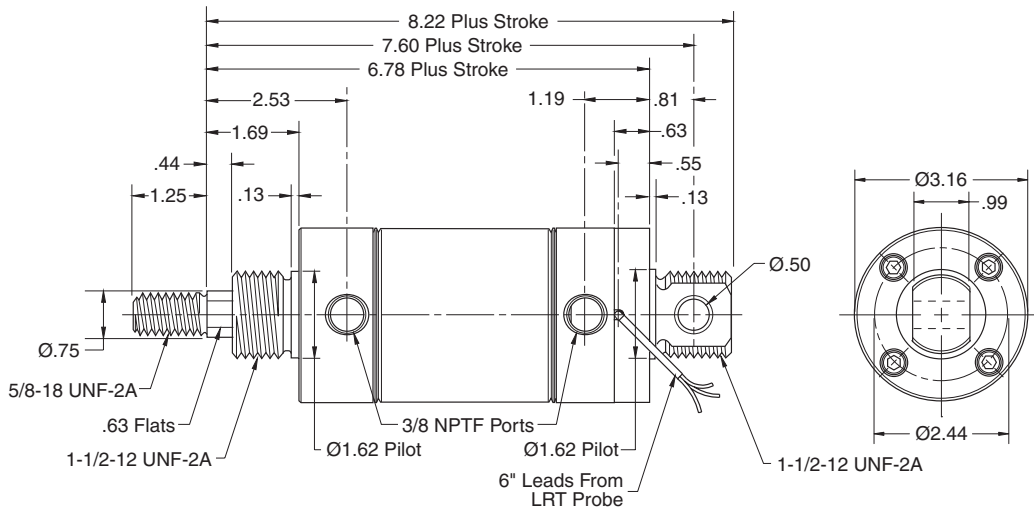
**Parker Hannifin Corporation**  
Pneumatic Division  
Richland, Michigan  
[www.parker.com/pneumatics](http://www.parker.com/pneumatics)

3" Bore Cylinders

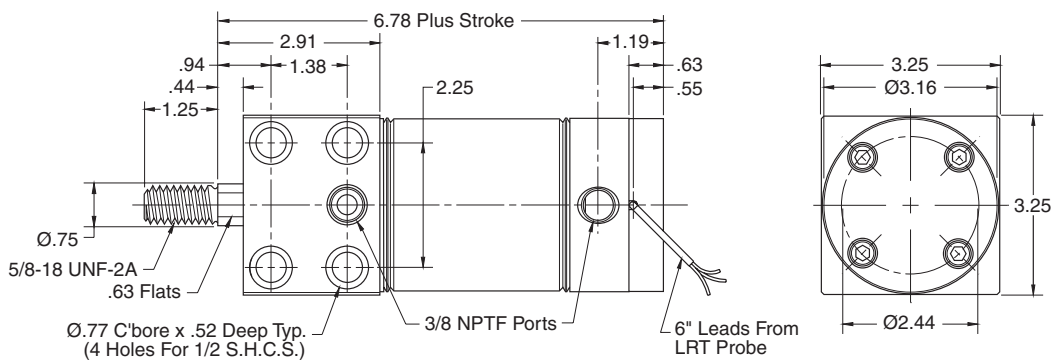
Style D



Style DXP



Style BFD



Pneumatic Cylinders	Round Body
	SR/SRM/SRD/SRDM Series
SRG/SRGM Series	SRX Series
	P1A Series
P Series	

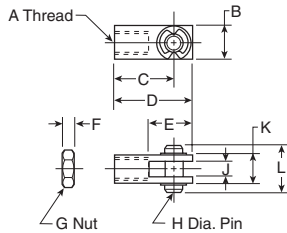


For inventory, lead times, and kit lookup, visit [www.pdnplu.com](http://www.pdnplu.com)

C46

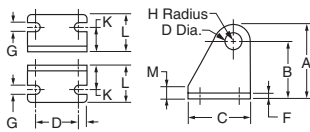
**Parker Hannifin Corporation**  
Pneumatic Division  
Richland, Michigan  
[www.parker.com/pneumatics](http://www.parker.com/pneumatics)

**Piston Rod Clevis**



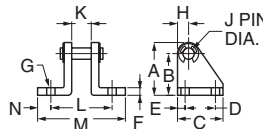
Bore size	A	B	C	D	E	F	G	H	J	K	L	Part number
1-1/16	3/8-24	.63	1.38	1.69	.94	.22	3/8-24	.31	.32	.63	.88	<b>L071300350</b>
1-1/2	7/16-20	.75	1.31	1.69	.94	.25	7/16-20	.38	.38	.75	1.03	<b>L071300400</b>
2	1/2-20	.88	1.88	2.31	1.31	.31	1/2-20	.44	.45	.88	1.14	<b>L071300550</b>
2-1/2, 3	5/8-18	1.00	2.25	2.75	1.50	.38	5/8-18	.50	.51	1.00	1.38	<b>L071300600</b>

**Pivot Brackets**



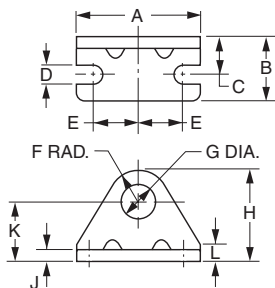
Bore size	A	B	C	D	E	F	G	H	J	K	L	M	Part number
1-1/16	1.31	1.00	1.31	.81	.25	.16	.28	.31	.315	.56	.88	.28	<b>L071310400</b>
1-1/2	1.63	1.25	1.63	1.00	.31	.19	.34	.38	.378	.69	1.13	.31	<b>L071310500</b>
2	1.81	1.38	1.81	1.19	.31	.25	.34	.44	.440	.75	1.19	.38	<b>L071310600</b>
2-1/2, 3	2.13	1.63	2.13	1.38	.38	.25	.41	.50	.503	.88	1.38	.38	<b>L071310700</b>

**Pivot Brackets**



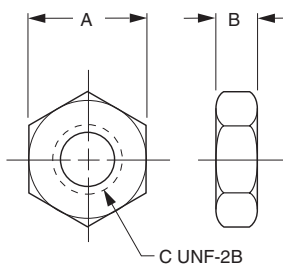
Bore size	A	B	C	D	E	F	G	H	J	K	L	M	N	Part number
1-1/16	1.31	1.00	1.31	.81	.25	.16	.28	.31	.312	.62	1.75	2.38	.31	<b>L071320250</b>
1-1/2	1.63	1.25	1.63	1.00	.31	.19	.34	.38	.375	.75	2.13	3.00	.44	<b>L071320350</b>
2	1.81	1.38	1.81	1.19	.31	.25	.34	.44	.437	.88	2.38	3.25	.44	<b>L071320450</b>
2-1/2, 3	2.13	1.63	2.13	1.38	.38	.25	.41	.50	.500	1.00	2.75	3.75	.50	<b>L071320550</b>

**Foot Brackets**



Bore size	A	B	C	D	E	F	G	H	J	K	L	Part number
1-1/16	2.13	1.16	.66	.28	.75	.75	.88	1.75	.16	1.00	.38	<b>L073790056</b>
1-1/2	2.75	1.44	.81	.35	1.00	.94	1.13	2.19	.19	1.25	.38	<b>L073790108</b>
2	3.00	1.59	.91	.35	1.19	1.06	1.26	2.44	.22	1.38	.44	<b>L073790116</b>
2-1/2	3.75	1.88	1.06	.41	1.50	1.19	1.38	2.81	.25	1.63	.50	<b>L073790125</b>
3	4.38	1.62	1.00	.35	1.75	1.25	1.64	3.14	.25	1.89	.89	<b>L073790140</b>

**Mounting Nut**



Bore size	A	B	C	Part number
1-1/16	1.31	.48	7/8-14	<b>L073801000</b>
1-1/2	1.69	.61	1-1/8-12	<b>L073801300</b>
2	1.88	.50	1-1/4-12	<b>L073801200</b>
2-1/2	2.06	.78	1-3/8-12	<b>L073801400</b>
3	2.25	.84	1-1/2-12	<b>L073801500</b>

Most popular.



For inventory, lead time, and kit lookup, visit [www.pdnplu.com](http://www.pdnplu.com)



Round Body  
 Pneumatic Cylinders

SRM/SRD/SRDM  
 Series

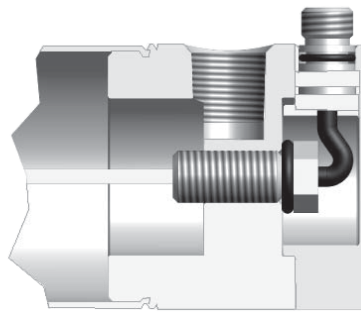
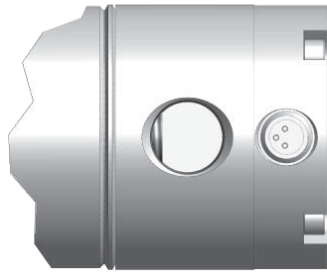
SRG/SRGM  
 Series

SRX  
 Series

P1A  
 Series

P  
 Series

**3-pin Nano Connector**



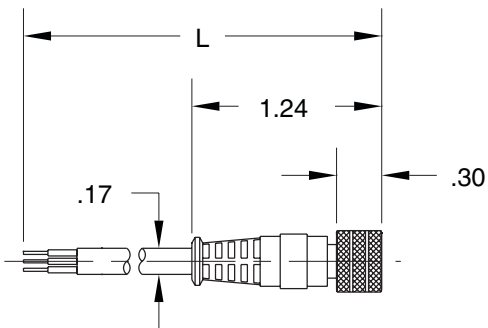
**Wire Color**

Wires	6" Leads	Plug option
Input	Red	Brown
Ground	Black	Blue
Output	White	Black

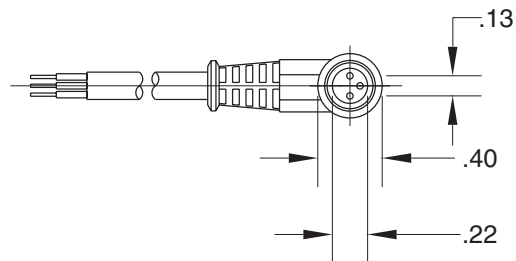
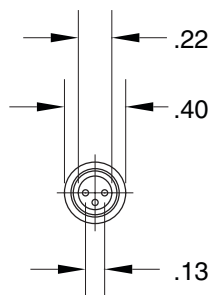
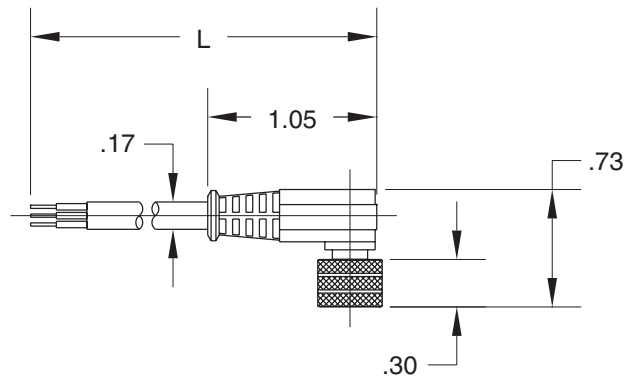
**Connectors**

Cable Length	Threaded straight connector	Threaded right angle connector
5 meters	<b>086620T005</b>	<b>086620R005</b>
2 meters	<b>086620T002</b>	<b>086620R002</b>

**Straight Connector**



**Right-angle Connector**



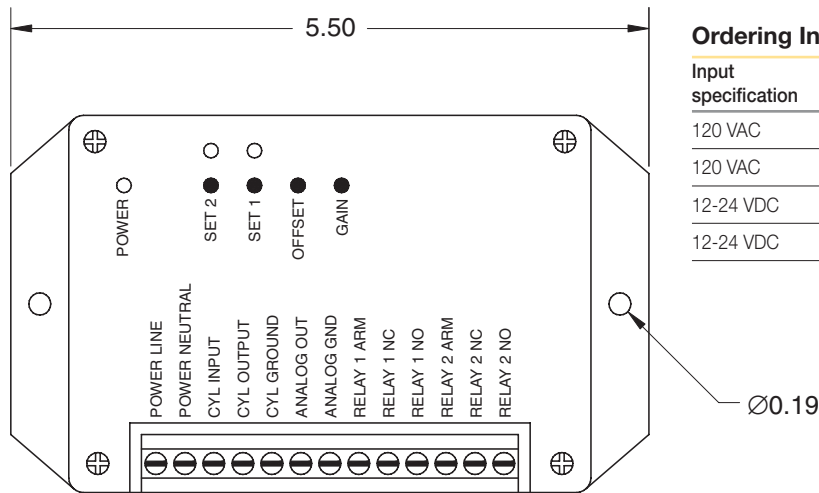
- C
- Round Body  
Pneumatic Cylinders
- SR/SRM/SRD/SRDM  
Series
- SRG/SRGM  
Series
- SRX  
Series
- P1A  
Series
- P  
Series



For inventory, lead times, and kit lookup, visit [www.pdnplu.com](http://www.pdnplu.com)

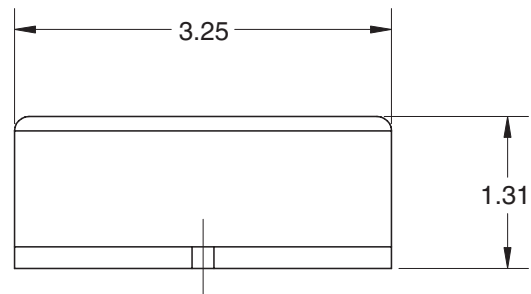
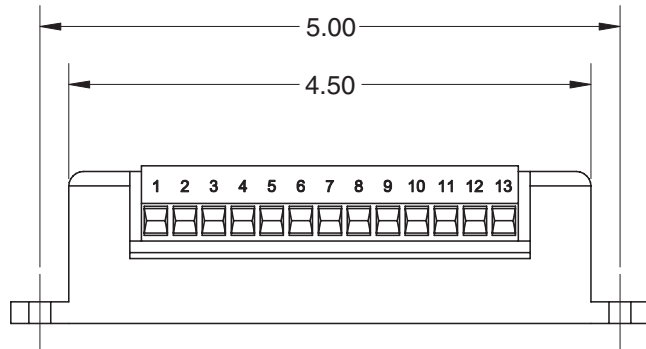


**Dual Set Point Controller, Part #149344000**



**Ordering Information**

Input specification	Output specification	Part number
120 VAC	0-10 V	1493440002
120 VAC	4-20 mA	1493440003
12-24 VDC	0-10 V	1493440004
12-24 VDC	4-20mA	1493440005



**Specifications**

Power Input Requirements	12 to 24 VDC, 0.1 amps, or 120 VAC, 60 Hz, 0.1 amps
Output specifications – Set Point	Relay (2) 2 amps @ 24 VDC or 120 VAC
Output Specifications – Scalable	0 to 10 V, 1 mA max. output current (10K ohm impedance min.) 4 to 20mA, into 500-ohm max. impedance
Maximum Zero Offset	50% of cylinder stroke
Minimum Span Range	50% of cylinder stroke
Enclosure Dimensions	1.31" h x 5.50" w x 3.25" d
Electronics Temperature Operating Range	40°F to 160°F

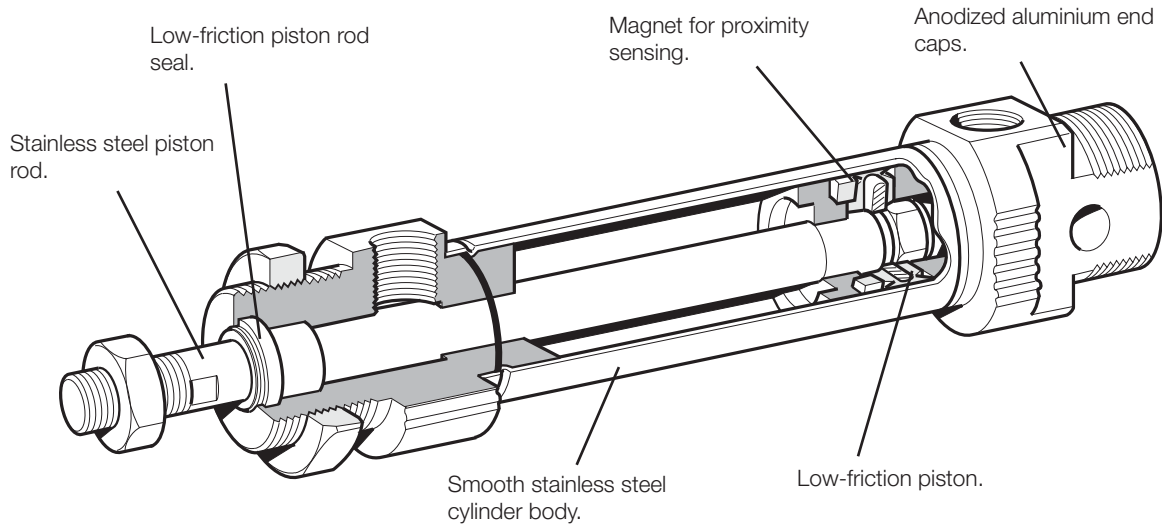
Please reference Parker Bulletin #0971-G-B2 for information regarding programming and operation of this controller.

  
**Round Body**  
**Pneumatic Cylinders**  
**SR/SRM/SRD/SRDM**  
 Series  
**SRG/SRGM**  
 Series  
**SRX**  
 Series  
**P1A**  
 Series  
**P**  
 Series



For inventory, lead time, and kit lookup, visit [www.pdnplu.com](http://www.pdnplu.com)

**P1A Series**



C	Round Body Pneumatic Cylinders
	SR/SRM/SRD/SRDM Series
	SRG/SRGM Series
	SRX Series
	P1A Series
	P Series

The Parker P1A series of pneumatic cylinders are intended for use in a wide range of applications. These cylinders are particularly suitable for lighter duties in the packaging, food and textile industries. Hygienic design, the use of corrosion-resistant materials and initial lubrication with our food-grade grease makes the cylinders suitable for food industry applications.

Proven design and high quality manufacturing throughout ensure long service life and optimum performance.

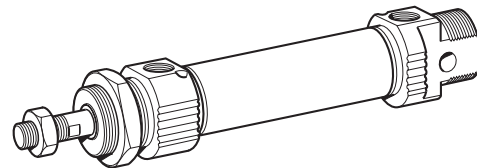
Mounting dimensions are in accordance with ISO 6432 and CETOP RP52P. This greatly simplifies installation and worldwide interchangeability.

The Mini ISO range is available with bumpers or adjustable pneumatic cushioning. Controlled by simple bleed screws for fine adjustment, the adjustable cushioned cylinders can be operated with higher mass loads and at higher speeds than those with fixed end cushioning bumpers.

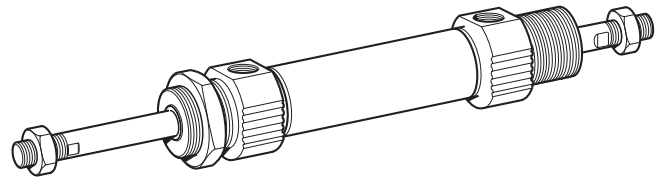
The Mini ISO range is also available in an all-stainless version with piston rod, cylinder body and end covers of stainless steel for use in extremely severe environments. Consult the Wadsworth, Ohio facility for more information.

A complete range of sensors for proximity sensing is available as accessories: both reed and solid state sensors are available. Either can be supplied with flying leads or cable and multi-pin connector. See Electronic Sensors section for specifications and part numbers.

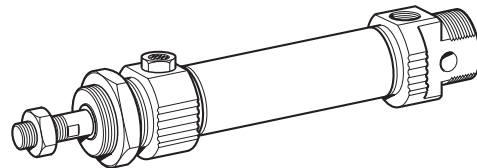
**Double Acting**



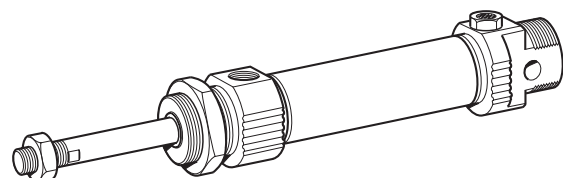
**Double Acting, Double Rod**



**Single-Acting, Spring Return**



**Single-Acting, Spring Extend**



For inventory, lead times, and kit lookup, visit [www.pdnplu.com](http://www.pdnplu.com)

C50

**Parker Hannifin Corporation**  
Pneumatic Division  
Richland, Michigan  
[www.parker.com/pneumatics](http://www.parker.com/pneumatics)

Features

- Conforms to ISO 6432 and CETOP RP52P standards
- 5 bore sizes, 10mm to 25mm
- Stainless steel body with black anodized aluminum end caps
- Stainless steel piston rod
- Magnetic piston and bumpers standard



Operating information

Operating pressure:	10 bar (145 PSIG)
Temperature range:	
Working	-20°C to 80°C (-4°F to 176°F)
High temperature version	
20mm, 25mm	-10°C to 150°C (14°F to 302°F)
10mm, 12mm, 16mm	-10°C to 120°C (14°F to 248°F)
Low temperature version	-40°C to 60°C (-40°F to 140°F)
Filtration requirements:	40 micron, dry filtered air

Ordering information

**P1A - S**

Bore size	
010	10mm
012	12mm
016	16mm
020	20mm
025	25mm

**016**

Cylinder type / function	
<b>M</b>	Double-acting, adjustable cushioning, Ø16-25 mm. Not for sealing material type F.
<b>D</b>	Double-acting, bumpers, Ø10 - Ø25
<b>F</b>	Double-acting, adjustable cushioning, double rod, Ø16-25 mm. Not for sealing material type F.
<b>K</b>	Double-acting, bumpers, double rod, Ø10 - Ø25
<b>S</b>	Single-acting, bumpers, spring return for retract stroke, Ø10-25 mm
<b>T</b>	Single-acting, bumpers, spring extend for advance stroke, Ø16-25 mm

**M**

**S**

**-**

**0025**

Stroke length, mm
E.g. 0025 = 25 mm
For standard stroke length and max length see table below.

Stroke Lengths																	
Cylinder model	Bore size	Stroke Length (* = standard, ° = non-standard, blank = N/A)															
		10	15	20	25*	30	40	50*	80*	100*	125*	160*	200*	250*	320*	400*	500*
<b>Double acting with fixed end-cushioning:</b>																	
P1A-S 010 D	10	•	•	•	•	•	•	•	•	•	•	•	•	•	•	•	•
P1A-S 012 D	12	•	•	•	•	•	•	•	•	•	•	•	•	•	•	•	•
P1A-S 016 D	16	•	•	•	•	•	•	•	•	•	•	•	•	•	•	•	•
P1A-S 020 D	20	•	•	•	•	•	•	•	•	•	•	•	•	•	•	•	•
P1A-S 025 D	25	•	•	•	•	•	•	•	•	•	•	•	•	•	•	•	•
<b>Double acting with adjustable end-cushioning:</b>																	
P1A-S 016 M	16			•	•	•	•	•	•	•	•	•	•	•	•	•	•
P1A-S 020 M	20			•	•	•	•	•	•	•	•	•	•	•	•	•	•
P1A-S 025 M	25			•	•	•	•	•	•	•	•	•	•	•	•	•	•
<b>Single acting:</b>																	
P1A-S 010 SS	10	•	•	•	•	•	•	•	•								
P1A-S 012 SS	12	•	•	•	•	•	•	•	•								
P1A-S 016 SS(TS)	16	•	•	•	•	•	•	•	•								
P1A-S 020 SS(TS)	20	•	•	•	•	•	•	•	•								
P1A-S 025 SS(TS)	25	•	•	•	•	•	•	•	•								

\* Standard stroke lengths in mm according to ISO 4393  
\*\* Not for the TS version

**Sensors**  
See section L for sensors.

Round Body Pneumatic Cylinders

SR/SRM/SRD/SRDM Series

SRG/SRGM Series

SRX Series

P1A Series

P Series



For inventory, lead time, and kit lookup, visit [www.pdnplu.com](http://www.pdnplu.com)

**Technical Data**

**Standard Specifications**

- Working pressure max 10 bar (145 PSI)
- Working temperature max 80°C (176°F)  
min -20°C (4°F)
- High-temperature version max 150°C (Ø20 and 25 mm) 302°F  
120°C (Ø10, 12 and 16 mm) 248°F  
min -10°C (14°F)
- Prelubricated, further lubrication is not normally necessary.
- If additional lubrication is introduced it must be continued.



**Material Specification**

Piston rod	Stainless steel, DIN X 10 CrNiS 18 9
Piston rod seal	Fluorocarbon rubber FPM
Piston rod bearing	Multilayer PTFE/steel
End covers	Anodized aluminium
O-ring, internal	Nitrile rubber, NBR
Cylinder barrel	Stainless steel, DIN X 5 CrNi 18 10
Piston, complete	Nitrile rubber, NBR/steel
Magnet holder	Thermoplastic elastomer
Magnet	Plastic-coated magnetic material
Return spring	Surface-treated steel
Cushioning screw	Stainless steel, DIN X 10 CrNiS 18 9

Cylinders are supplied complete with nose mounting and piston rod nuts.

Cylinders with double piston rods are supplied with two piston rod nuts

**Variants Mini ISO:**

**High-temperature version, type F:**

Piston rod seal	Fluorocarbon rubber, FPM
Piston complete, Ø10-Ø16	HNBR/steel
Piston complete, Ø20-Ø25	FPM/steel

**PTFE and copper free cylinders, type N:**

Piston rod bearing	PA plastic
--------------------	------------

**Cylinders with outer sealings in fluorocarbon, type V:**

Piston rod seal/ Scraper ring	Fluorocarbon rubber, FPM
----------------------------------	--------------------------

Note: Spare part = new cylinder

**Quick Reference**

Model #	Cylinder		Piston rod			Total weight at 0mm stroke (lbs)	Additional weight per 10mm stroke (lbs)	Air consumption	Port size
	Bore (mm)	Area (cm <sup>2</sup> )	Dia. (mm)	Area (cm <sup>2</sup> )	Thread				
<b>Double acting, cushioned stroke</b>									
P1A-S 010 D	10	0.78	4	0.13	M4	0.09	0.007	0.0004 †	M5
P1A-S 012 D	12	1.13	6	0.28	M6	0.15	0.009	0.0005 †	M5
P1A-S 016 D	16	2.01	6	0.28	M6	0.20	0.012	0.0009 †	M5
P1A-S 020 D	20	3.14	8	0.50	M8	0.40	0.015	0.0010 †	G1/8
P1A-S 025 D	25	4.91	10	0.78	M10x1.25	0.89	0.025	0.0023 †	G1/8
<b>Double acting, adjustable cushioning</b>									
P1A-S 016 M	16	2.01	6	0.28	M6	0.20	0.012	0.0009 †	M5
P1A-S 020 M	20	3.14	8	0.50	M8	0.40	0.015	0.0010 †	G1/8
P1A-S 025 M	25	4.91	10	0.78	M10x1.25	0.89	0.025	0.0023 †	G1/8
<b>Single acting</b>									
P1A-S 010 SS	10	0.78	4	0.13	M4	0.09	0.007	0.0002 †	M5
P1A-S 012 SS	12	1.13	6	0.28	M6	0.18	0.009	0.0003 †	M5
P1A-S 016 SS(TS)	16	2.01	6	0.28	M6	0.22	0.012	0.0005 †	M5
P1A-S 020 SS(TS)	20	3.14	8	0.50	M8	0.40	0.015	0.0008 †	G1/8
P1A-S 025 SS(TS)	25	4.91	10	0.78	M10x1.25	0.58	0.025	0.0013 †	G1/8

† Free air consumption per 10 mm stroke length for a double stroke at 6 bar (87 PSI)

Round Body Pneumatic Cylinders  
SR/SRM/SRD/SRDM Series  
SRG/SRGM Series  
SRX Series  
P1A Series  
P Series



For inventory, lead times, and kit lookup, visit [www.pdnplu.com](http://www.pdnplu.com)

**Cylinder Forces**

Indicated cylinder forces are theoretical and should be reduced according to the working conditions.

**Double Acting**

Model number	Bore size mm	Theoretical Piston Force (lbs) at 6 bar (87 PSI)	
		Extension	Retraction
P1A-S 010 D	10	10.57	8.76
P1A-S 012 D	12	15.07	11.25
P1A-S 016 D	16	26.98	23.15
P1A-S 020 D	20	42.27	35.52
P1A-S 025 D	25	66.10	55.53
P1A-S 016 M	16	26.98	23.16
P1A-S 020 M	20	42.27	35.52
P1A-S 025 M	25	66.10	55.53

**Single Acting**

Model number	Stroke	Theoretical piston force (lbs) at 6 bar (87 PSI)			
		Spring retraction		Spring extension	
		lbs. max	lbs. min	lbs. max	lbs. min
P1A-S 010 SS	10	8.5	8.1	2.4	2.0
	15	8.5	8.1	2.4	2.0
	25	8.7	8.1	2.4	2.0
	40	8.5	7.6	2.9	2.0
	50	8.7	7.6	2.9	1.7
	80	8.7	7.6	2.9	1.7
P1A-S 012 SS	10	11.9	11.4	3.6	3.1
	15	11.9	11.4	3.6	3.1
	25	12.3	11.4	3.6	2.7
	40	11.9	10.8	4.2	3.3
	50	11.9	10.8	4.2	3.1
	80	12.3	10.8	4.2	2.7
P1A-S 016 SS(TS)	10	22.0 (19.1)	22.2 (18.8)	4.7 (4.2)	4.0 (4.0)
	15	23.1 (19.3)	22.2 (18.8)	4.7 (4.2)	3.8 (3.8)
	25	23.8 (19.8)	22.2 (18.8)	4.7 (4.2)	3.3 (3.3)
	40	23.8 (20.3)	21.3 (18.8)	5.6 (4.2)	3.1 (3.1)
	50	24.2 (20.4)	21.3 (18.8)	5.6 (4.2)	2.7 (2.7)
	80	24.0 (21.3)	21.3 (18.8)	5.6 (4.2)	2.9 (2.9)
P1A-S 020 SS(TS)	10	36.6 (29.6)	36.1 (29.2)	6.1 (6.3)	5.6 (5.8)
	15	36.8 (29.8)	36.1 (29.2)	6.1 (6.3)	5.4 (5.6)
	25	37.5 (30.3)	36.1 (29.2)	6.1 (6.3)	4.7 (5.1)
	40	37.3 (31.0)	35.7 (29.2)	6.5 (6.3)	4.9 (4.9)
	50	37.7 (31.4)	35.7 (29.2)	6.5 (6.3)	4.5 (4.5)
	80	38.2 (31.2)	36.1 (24.2)	6.1 (11.2)	4.0 (4.2)
P1A-S 025 SS(TS)	10	57.5 (46.1)	56.9 (45.6)	9.2 (9.9)	8.5 (9.4)
	15	58.0 (46.5)	56.9 (45.6)	9.2 (9.9)	8.1 (9.0)
	25	58.9 (47.2)	56.9 (45.6)	9.2 (9.9)	7.2 (8.3)
	40	58.7 (48.1)	56.2 (45.6)	9.9 (9.9)	7.4 (7.4)
	50	59.4 (48.8)	56.2 (45.6)	9.9 (9.9)	6.7 (6.7)
	80	59.4 (50.1)	56.4 (46.3)	9.6 (9.2)	6.7 (5.4)



Round Body  
Pneumatic Cylinders

---

SR/SRM/SRD/SRDM  
Series

---

SRG/SRGM  
Series

---

SRX  
Series

---

P1A  
Series

---

P  
Series



For inventory, lead time, and kit lookup, visit [www.pdnplu.com](http://www.pdnplu.com)

C53

**Parker Hannifin Corporation**  
 Pneumatic Division  
 Richland, Michigan  
[www.parker.com/pneumatics](http://www.parker.com/pneumatics)

**Cushioning**

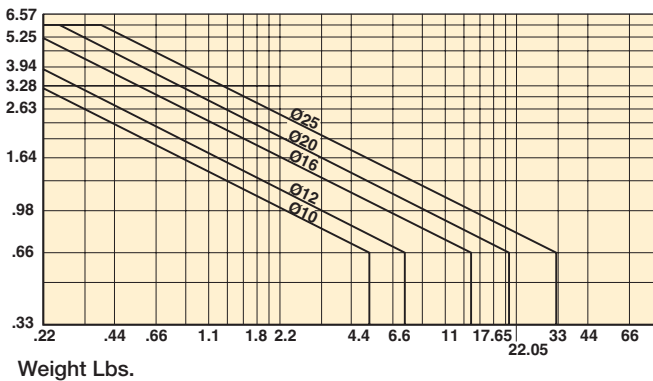
Use the diagram below to determine the necessary size of cylinder to provide the requisite cushioning performance. The maximum cushioning performance, as indicated in the diagram, is based on the following assumptions:

- Low load, i.e. low pressure drop across the piston
- Steady-state piston speed
- Correctly adjusted cushioning screw

The load is the sum of the internal and external friction, together with any gravity forces. At high relative loading it is recommended that, for a given speed, the load should be reduced by a factor of 2.5, or that, for a given mass, the speed should be reduced by a factor of 1.5. These factors apply in relation to the maximum performance as shown in the diagram.

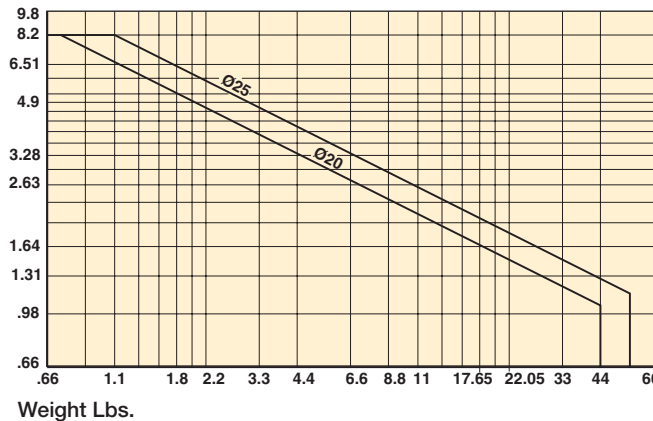
**Fixed End-Cushioning (Bumpers)**

Speed Ft./Sec.



**Adjustable Pneumatic End-Cushioning**

Speed Ft./Sec.



**Double-acting cushioned cylinders**

Adjustable pneumatic cushioning permits greater loads and higher operating speeds, making the cylinders suitable for more demanding applications.

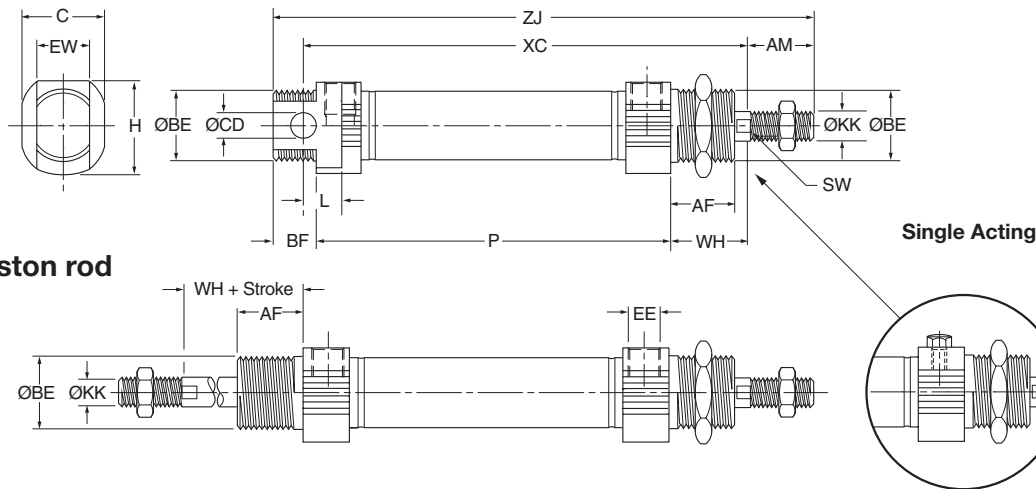
These cylinders are available in bores of 16, 20 and 25 mm, with stroke lengths from 20 mm to 500 mm.

**C**  
**Round Body Pneumatic Cylinders**  
**SR/SRM/SRD/SRDM Series**  
**SRG/SRGM Series**  
**SRX Series**  
**P1A Series**  
**P Series**

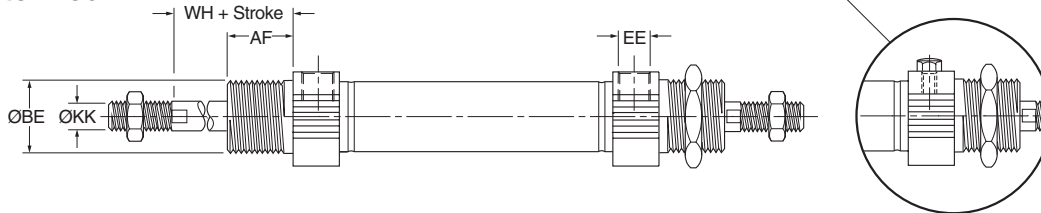


For inventory, lead times, and kit lookup, visit [www.pdnplu.com](http://www.pdnplu.com)

**Double acting cylinders**



**Double piston rod**



Bore size mm	AM <sup>0/2</sup> mm	BE	AF mm	BF mm	C mm	CD <sup>h9</sup> mm	EE	EW mm	H mm	KK	L mm	SW mm	WH <sub>±1,2</sub> mm
10	12	M12x1.25	12	10	14.0	4	M5	8	16.7	M4	6	-	16
12	16	M16x1.5	18	13	18.0	6	M5	12	19.1	M6	9	5	22
16 <sup>1)</sup>	16	M16x1.5	18	13	18.0	6	M5	12	19.1	M6	9	5	22
16 <sup>2)</sup>	16	M16x1.5	18	13	25.0	6	M5	12	24.0	M6	9	5	22
20	20	M22x1.5	20	14	24.0	8	G1/8	16	27.0	M8	12	7	24
25	22	M22x1.5	22	14	27.5	8	G1/8	16	29.0	M10x1.25	12	9	28

1) P1A-S016DS/SS/TS

2) P1A-S016MS

**Double acting cylinders**

Bore size mm	XC mm	ZJ mm	P mm
10	64 + stroke	84 + stroke	46 + stroke
12	75 + stroke	99 + stroke	48 + stroke
16	82 + stroke	104 + stroke	53 + stroke
20	95 + stroke	125 + stroke	67 + stroke
25	104 + stroke	132 + stroke	68 + stroke

**Single-acting, spring return, type SS**

Bore size mm	XC (mm) at various strokes						ZJ (mm) at various strokes						P (mm) at various strokes					
	10	15	25	40	50	80	10	15	25	40	50	80	10	15	25	40	50	80
10	74	79	89	126	136	174	94	99	109	146	156	194	56	61	71	108	118	156
12	85	90	100	132	142	185	109	114	124	156	166	209	58	63	73	105	115	158
16	92	97	107	122	132	184	114	119	129	144	154	206	63	68	78	93	103	155
20	105	110	120	135	145	191	135	140	150	165	175	221	77	82	92	107	117	163
25	114	119	129	144	154	201	142	147	157	172	182	229	78	83	93	108	118	165

**Single-acting, spring-extended, type TS**

Bore size mm	ZC <sup>3)</sup> (mm) at various strokes						ZJ <sup>3)</sup> (mm) at various strokes						P (mm) at various strokes					
	10	15	25	40	50	80	10	15	25	40	50	80	10	15	25	40	50	80
16	107	112	122	137	147	-	134	139	149	164	174	-	78	83	93	108	118	-
20	120	125	135	150	160	195	156	161	171	186	196	231	92	97	107	122	132	167
25	129	134	144	159	169	205	165	170	180	195	205	241	93	98	108	123	133	169

3) With piston rod retracted, as shown in the dimension drawing  
 Length tolerances ±1 mm    Stroke length tolerance +1.5/0 mm



For inventory, lead time, and kit lookup, visit [www.pdnplu.com](http://www.pdnplu.com)

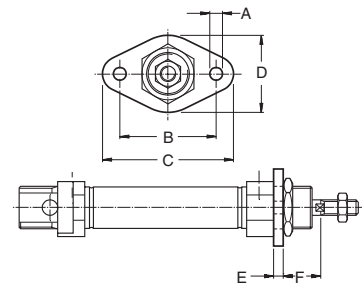
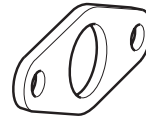
C55

**Parker Hannifin Corporation**  
 Pneumatic Division  
 Richland, Michigan  
[www.parker.com/pneumatics](http://www.parker.com/pneumatics)

**Round Body Pneumatic Cylinders**  
**SR/ SRM/ SRD/ SRDM Series**  
**SRG/ SRGM Series**  
**SRX Series**  
**P1A Series**  
**P Series**

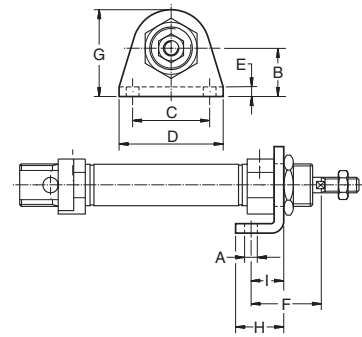
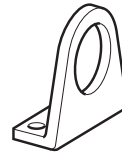
**Flange - MF8**

Cylinder Ø mm	A	B	C	D	E	F	Weight lbs	Part number
10	4.5	30	40	22	3	13	0.025	<b>P1A-4CMB</b>
12-16	5.5	40	52	30	4	18	0.055	<b>P1A-4DMB</b>
20	6.6	50	66	40	5	19	0.100	<b>P1A-4HMB</b>
25	6.6	50	66	40	5	23	0.100	<b>P1A-4HMB</b>



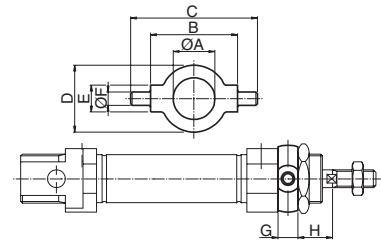
**Foot - MS3**

Cylinder Ø mm	A mm	B mm	C mm	D mm	E mm	F mm	G mm	H mm	I mm	Weight lbs	Part number
10	4.5	16	25	35	3	24	26.0	16	11	0.045	<b>P1A-4CMF</b>
12-16	5.5	20	32	42	4	32	32.5	20	14	0.08	<b>P1A-4DMF</b>
20	6.5	25	40	54	5	36	45.0	25	17	0.18	<b>P1A-4HMF</b>
25	6.5	25	40	54	5	40	45.0	25	17	0.18	<b>P1A-4HMF</b>



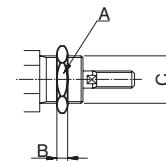
**Cover Trunnion**

Cylinder Ø mm	A mm	B h14 mm	C mm	D mm	E e9 mm	F mm	G mm	H mm	Weight lbs	Part number
10	12.5	26	38	20	8	4	6	10	0.03	<b>P1A-4CMJ</b>
12-16	16.5	38	58	25	10	6	8	14	0.07	<b>P1A-4DMJ</b>
20	22.5	46	66	30	10	6	8	16	0.08	<b>P1A-4HMJ</b>
25	22.5	46	66	30	10	6	8	20	0.08	<b>P1A-4HMJ</b>



**Mounting Nut**

Cylinder Ø mm	A mm	B mm	C mm	Weight lbs	Part number
10	19	6	M12x1.25	0.02	<b>9127385101</b>
12-16	24	8	M16x1.50	0.04	<b>9126725406</b>
20-25	32	11	M22x1.50	0.09	<b>9126725407</b>



Most popular.



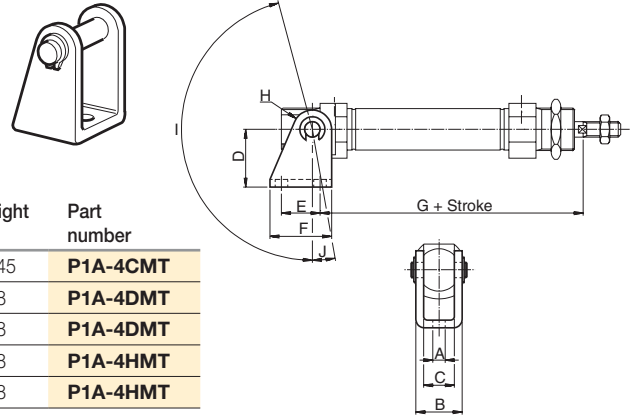
For inventory, lead times, and kit lookup, visit [www.pdnplu.com](http://www.pdnplu.com)

C56

**Parker Hannifin Corporation**  
 Pneumatic Division  
 Richland, Michigan  
[www.parker.com/pneumatics](http://www.parker.com/pneumatics)

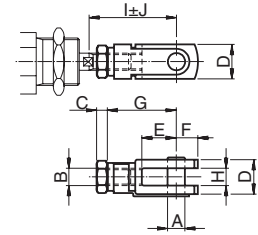
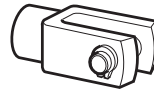


**Clevis Bracket**



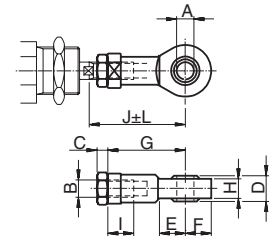
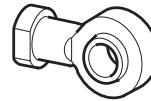
Cylinder Ø mm	A mm	B mm	C mm	D mm	E mm	F mm	G mm	H mm	I °	J °	Weight lbs	Part number
10	4.5	13	8	24	12.5	20	65.3	5	160	17	0.045	<b>P1A-4CMT</b>
12	5.5	18	12	27	15.0	25	73.0	7	170	15	0.08	<b>P1A-4DMT</b>
16	5.5	18	12	27	15.0	25	80.0	7	170	15	0.08	<b>P1A-4DMT</b>
20	6.5	24	16	30	20.0	32	91.0	10	165	10	0.18	<b>P1A-4HMT</b>
25	6.5	24	16	30	20.0	32	100.0	10	165	10	0.18	<b>P1A-4HMT</b>

**Rod clevis**



Cylinder Ø mm	A mm	B	C mm	D mm	E mm	F mm	G mm	H mm	I mm	J mm	Weight lbs	Part number
10	4	M4	2.2	8	8	5	16	4	22.0	2.0	0.015	<b>P1A-4CRC</b>
12-16	6	M6	3.2	12	12	7	24	6	31.0	3.0	0.05	<b>P1A-4DRC</b>
20	8	M8	4.0	16	16	10	32	8	40.5	3.5	0.10	<b>P1A-4HRC</b>
25	10	M10 x 1.25	5.0	20	20	12	40	10	49.0	3.0	0.21	<b>P1A-4JRC</b>

**Swivel Rod Eye**

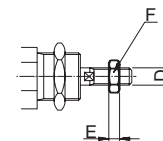


Cylinder Ø mm	A mm	B	C mm	D mm	E mm	F mm	G mm	H mm	I mm	J mm	K mm	L mm	Weight lbs	Part number
10	5	M4	2.2	8	10	9	27	6.0	8	33.0	9	2.0	0.04	<b>P1A-4CRS</b>
12-16	6	M6	3.2	9	10	10	30	6.8	9	38.5	11	1.5	0.06	<b>P1A-4DRS</b>
20	8	M8	4.0	12	12	12	36	9.0	12	46.0	14	2.0	0.10	<b>P1A-4HRS</b>
25	10	M10 x 1.25	5.0	14	14	14	43	10.5	15	52.5	17	2.5	0.19	<b>P1A-4JRS</b>

**Rod Nut**

Stainless Steel, DIN x 5 CrNi 18 10

Cylinder Ø mm	D mm	F mm	E mm	Weight lbs	Part number
10	M4	7	2.2	0.002	<b>9127385121</b>
12-16	M6	10	3.2	0.004	<b>9127385122</b>
20	M8	13	4.0	0.010	<b>9127385123</b>
25	M10x1.25	17	5.0	0.015	<b>9126725404</b>



Most popular.



For inventory, lead time, and kit  
 lookup, visit [www.pdnplu.com](http://www.pdnplu.com)

C57



Round Body  
 Pneumatic Cylinders

SR/SRM/SRD/SRDM  
 Series

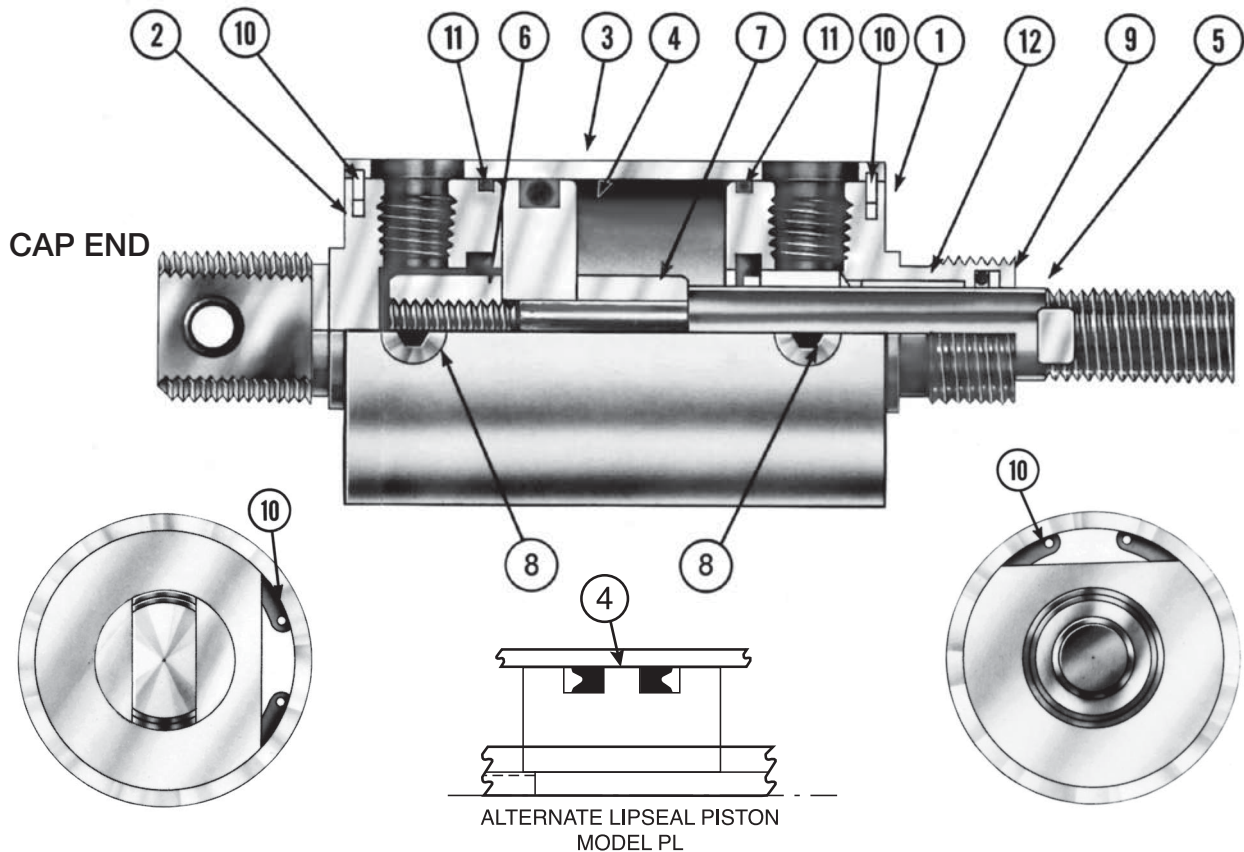
SRG/SRGM  
 Series

SRX  
 Series

P1A  
 Series

P  
 Series

P Series



Features

- ①② **Heads and Caps** are lightweight aluminum for maximum corrosion resistance. The cap is provided with a steel pivot bushing.
- ③ **Cylinder Body** is hard anodized aluminum for corrosion and abrasion resistance. The smooth I.D. finish provides long seal life.
- ④ **The Piston** is available with either O-Ring or Lipseal® design.
- ⑤ **Piston Rod** is chrome plated steel.\* The piston is secured to the rod with anaerobic adhesive. Full diameter threads are provided for maximum strength. Wrench flats are standard.
- ⑥⑦ **Adjustable Cushions** are available on 2" thru 4" bore sizes, while fixed cushions are available on 1-1/8" and 1-1/2" bore sizes.
- ⑧ **The Cushion Adjustment Needle** is recessed and retained for precise, safe adjustment on all adjustable cushions.
- ⑨ The wear-compensating **Rod Seal** design conforms to pressure variations and provides maximum seal life.
- ⑩ **High Strength Steel Retaining Snap Ring** (210,000 PSI ultimate) is precision made to securely lock the head and cap in place. Easily removed for quick disassembly.
- ⑪ **O-Ring Static Tube Seal** is standard for positive no-leak sealing.
- ⑫ **Rod Bearing** is low friction bronze for high performance and longer wear.

\* 1-1/8" bore has standard 416 stainless steel piston rod material.

Round Body Pneumatic Cylinders	SR/SRM/SRD/SRDM Series
	SRG/SRGM Series
SRX Series	P1A Series
P Series	



For inventory, lead times, and kit lookup, visit [www.pdnplu.com](http://www.pdnplu.com)

## Features

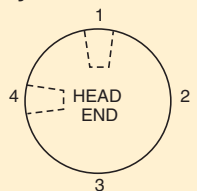

- Repairable design, aluminum construction
- 6 bore sizes: 1-1/8" to 4"
- Double-acting, spring-return and spring-extend models
- Cushions optional at either or both ends
- Universal nose and tang mounts
- Standard stroke lengths to 20 inches in one inch increments, plus 1-1/2", 2-1/2" and 3-1/2" strokes. Fraction strokes and strokes over 20 inches are available upon request.



## Operating information

Operating pressure:	150 PSIG (8 bar)
Temperature range:	
Standard seals	-10°F to 165°F (-23°C to 74°C)
Fluorocarbon seals	-10°F to 250°F (-23°C to 121°C)
Filtration requirements:	40 micron, dry filtered air

## Ordering information

<b>2-1/2"</b>	<b>C</b>	<b>K</b>		<b>P</b>	<b>L</b>	<b>U</b>				<b>1</b>	<b>6</b>		<b>C</b>	<b>X6"</b>
<b>Bore size</b> 1-1/8" 1-1/2" 2" 2-1/2" 3" 4"				<b>Series</b>	<b>Piston</b> Blank O-ring piston L Lipseal piston Sensors available on lipseal pistons only.								<b>Cushion cap end</b> Blank No cushion C Cushion cap end	<b>Stroke</b> Specify in inches. Show times symbol "X" just ahead of stroke length.
<b>Cushion head end</b> Blank No cushion C Cushion head end					<b>Ports</b> U N.P.T.F.									
<b>Double rod</b> Blank Single rod K Double rod					<b>Seals / options</b> Blank Buna-N V Fluorocarbon M Magnet with Buna-N seals <sup>1</sup>							<b>Rod material</b> Blank Standard rod D 416 Stainless steel <sup>2</sup>		
<b>Mounting style</b> Blank Standard N No tang A Dual tang					<b>Spring</b> E Spring extend R Spring return							<b>Rod thread</b> 6 Standard 3 Special (For special rod end specify "CC" thread Dia. A and LE or LE1 or Dim. or submit sketch.)		
<b>Safety Cushion Adjustment Location</b> 					<b>Special number</b> Use "S" symbol only if special feature is required (specify). NOTE: Do not use symbol "S" for rod end modification.							<b>Rod diameter style</b> 1 Standard For double rod cylinders specify rod code twice.		
With port in position 1, cushion location will be position 4.					<b>Sensors</b> See section L for sensors. 									

For ordering purposes, when special options or common modifications are requested, the factory will assign a sequential part number in place of the model number.



For inventory, lead time, and kit lookup, visit [www.pdnplu.com](http://www.pdnplu.com)



## Specifications

- Nominal pressure – up to 150 PSI air
- Repairable design
- Bore sizes: 1-1/8", 1-1/2", 2", 2-1/2", 3" and 4"
- Double-acting, Spring-return and Spring-extend models
- Cushions optional at either or both ends
- Universal nose and tang mounts
- Factory pre-lubricated
- Standard temperature range: -10°F to 165°F. fluorocarbon seals for operation up to 250°F are available at extra cost.
- Standard stroke lengths to 20 inches in one inch increments, plus 1-1/2", 2-1/2" and 3-1/2" strokes. Fraction strokes and strokes over 20 inches are available upon request.

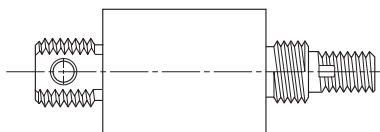
## Round Body Pneumatic Cylinders P Series, Aluminum

### DANGER

The piston to rod threaded connection is secured with an anaerobic adhesive which is temperature sensitive. Operating cylinders in excess of the following recommendations can cause the piston and piston rod assembly to unthread. Cylinders ordered with standard seals (Buna-N) are assembled with an anaerobic adhesive with a maximum operating temperature rating of 165°F. Cylinders ordered with Fluorocarbon seals are assembled with an anaerobic adhesive with a maximum operating temperature rating of 250°F.

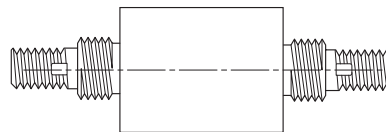
Cylinders originally manufactured with standard seals (Buna-N) that will be exposed to an ambient temperature above 165°F must be modified for higher temperature service. Contact your local factory immediately and arrange for the piston to piston rod connection to be properly modified for the higher temperature service.

### Mounting Styles Available



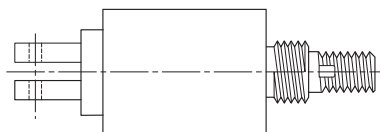
**Model P** – O-Ring Piston – Single Rod  
1-1/8" Bore thru 3" Bore

**Model PL** – Lipseal Piston – Single Rod  
1-1/8" Bore thru 4" Bore



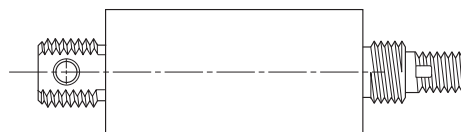
**Model KP** – O-Ring Piston – Double Rod  
1-1/8" Bore thru 3" Bore

**Model KPL** – Lipseal Piston – Double Rod  
1-1/8" Bore thru 4" Bore



**Model AP** – O-Ring Piston – Single Rod  
1-1/8" Bore thru 3" Bore

**Model APL** – Lipseal Piston – Single Rod  
1-1/8" Bore thru 4" Bore



**Model PR** – O-Ring Piston – Spring Return

**Model PE** – O-Ring Piston – Spring Extend  
1-1/8" Bore thru 3" Bore

**Model PLR** – Lipseal Piston – Spring Return

**Model PLE** – Lipseal Piston – Spring Extend  
1-1/8" Bore thru 4" Bore

### Force Data

(to determine force multiply operating pressure by area figures below)

Bore size	Rod dia.	Major area (sq. in.)	Minor area (sq. in.)
1-1/8"	3/8"	0.992	0.882
1-1/2"	1/2"	1.766	1.570
2"	5/8"	3.141	2.835
2-1/2"	3/4"	4.906	4.464
3"	3/4"	7.065	6.623
4"	1"	12.560	11.775

### Cylinder Cushion Lengths

Bore	Head	Cap
1-1/8"	0.560"	0.560"
1-1/2" & 2"	0.750"	0.750"
2-1/2" & 3"	0.875"	0.875"
4"	1.250"	1.250"

  
 Round Body  
 Pneumatic Cylinders  
 SR/SRM/SRD/SRDM  
 Series  
 SRG/SRGM  
 Series  
 SRX  
 Series  
 P1A  
 Series  
 P  
 Series



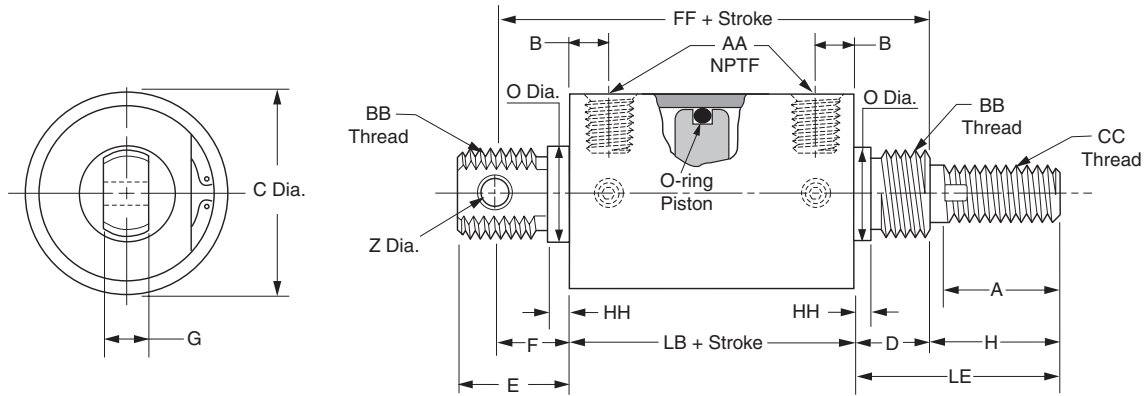
For inventory, lead times, and kit lookup, visit [www.pdnplu.com](http://www.pdnplu.com)

C60

**Parker Hannifin Corporation**  
 Pneumatic Division  
 Richland, Michigan  
[www.parker.com/pneumatics](http://www.parker.com/pneumatics)

**Model P**

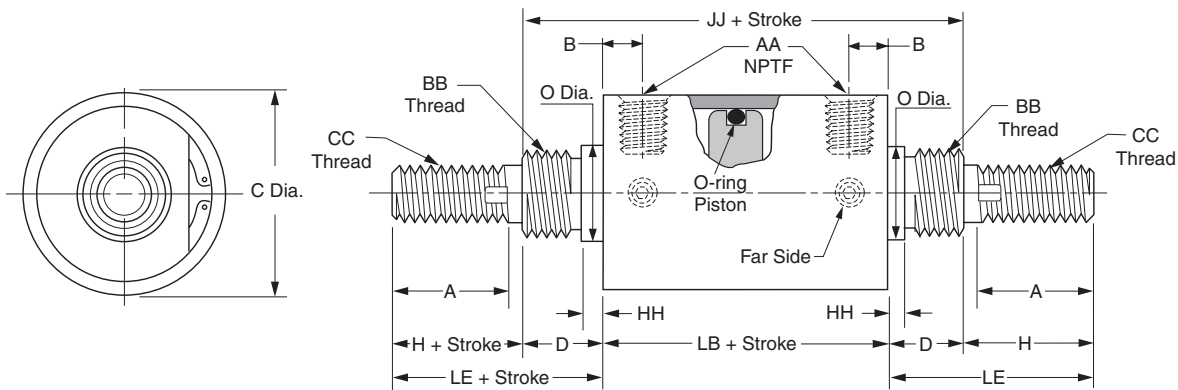
O-ring piston – single rod



Model P cylinders are available without tang covered by dimension E minus HH at no extra charge. To order specify Model NP.

**Model KP**

O-ring piston – double rod



Mounting nuts not supplied with cylinder.

**Model P and KP single and double rod cylinders**

Bore Size	Rod Dia.	LB	B	C	D	E	F	G	H	A	O	Z	AA	BB	CC	FF	HH	JJ	LE
1-1/8	3/8	2-1/16	13/32	1-3/8	5/8	1	11/16	3/8	1	7/8	3/4	1/4	1/8	3/4-16	3/8-16	3-3/8	3/32	3-5/16	1-5/8
1-1/2	1/2	2-5/8	1/2	1-3/4	7/8	1-1/4	7/8	1/2	1-7/16	1-1/4	1-1/16	5/16	1/4	1-14	1/2-13	4-3/8	1/8	4-3/8	2-5/16
2	5/8	2-5/8	1/2	2-1/4	7/8	1-1/4	7/8	1/2	1-7/16	1-1/4	1-1/16	5/16	1/4	1-14	5/8-11	4-3/8	1/8	4-3/8	2-5/16
2-1/2	3/4	3	5/8	2-3/4	1	2	1-3/8	5/8	1-11/16	1-1/2	1-3/8	7/16	3/8	1-3/8-12	3/4-10	5-3/8	3/16	5	2-11/16
3	3/4	3	5/8	3-1/4	1	2	1-3/8	5/8	1-11/16	1-1/2	1-3/8	7/16	3/8	1-3/8-12	3/4-10	5-3/8	3/16	5	2-11/16

Note: 4" bore size offered only with Lipseal Piston.  
 FLUOROCARBON SEALS for operation to 250°F are available at extra cost. Specify model PV or KP.V.

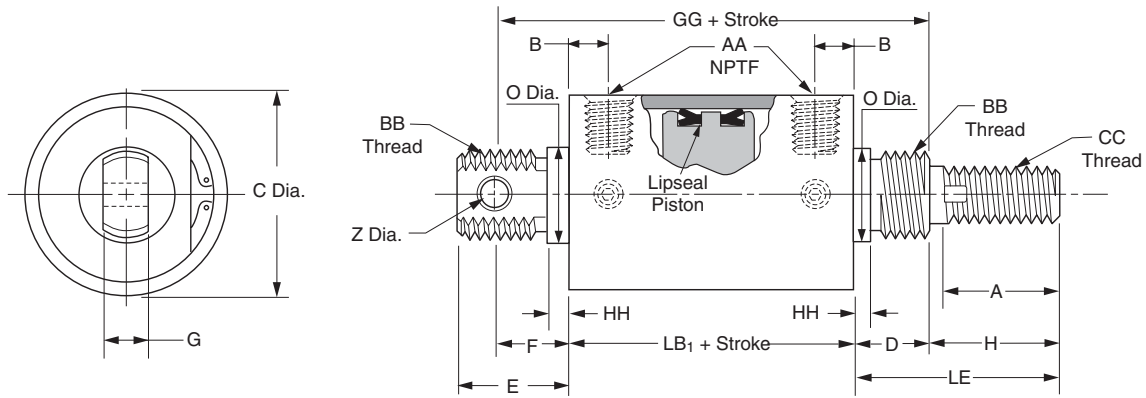
**Round Body Pneumatic Cylinders**  
 SR/SRM/SRD/SRDM Series  
 SRG/SRGM Series  
 SRX Series  
 P1A Series  
**P Series**



For inventory, lead time, and kit lookup, visit [www.pdnplu.com](http://www.pdnplu.com)

**Model PL**

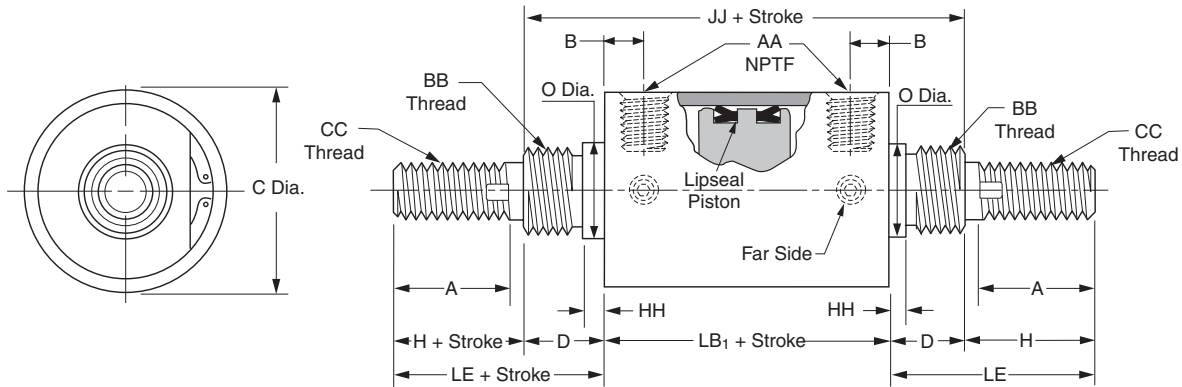
Lipseal piston – single rod



Model PL cylinders are available without tang covered by dimension E minus HH at no extra charge. To order specify Model NPL.

**Model KPL**

Lipseal piston – double rod



Mounting nuts not supplied with cylinder.

**Model PL and KPL single and double rod cylinders**

Bore Size	Rod Dia.	LB <sub>1</sub>	B	C	D	E	F	G	H	A	O	Z	AA	BB	CC	GG	HH	KK	LE
1-1/8	3/8	3-1/16	13/32	1-3/8	5/8	1	11/16	3/8	1	7/8	3/4	1/4	1/8	3/4-16	3/8-16	4-3/8	3/32	4-5/16	1-5/8
1-1/2	1/2	3-5/8	1/2	1-3/4	7/8	1-1/4	7/8	1/2	1-7/16	1-1/4	1-1/16	5/16	1/4	1-14	1/2-13	5-3/8	1/8	5-3/8	2-5/16
2	5/8	3-5/8	1/2	2-1/4	7/8	1-1/4	7/8	1/2	1-7/16	1-1/4	1-1/16	5/16	1/4	1-14	5/8-11	5-3/8	1/8	4-3/8	2-5/16
2-1/2	3/4	4	5/8	2-3/4	1	2	1-3/8	5/8	1-11/16	1-1/2	1-3/8	7/16	3/8	1-3/8-12	3/4-10	6-3/8	3/16	6	2-11/16
3	3/4	4	5/8	3-1/4	1	2	1-3/8	5/8	1-11/16	1-1/2	1-3/8	7/16	3/8	1-3/8-12	3/4-10	6-3/8	3/16	6	2-11/16
4	1	5-1/2	15/16	4-3/8	1-1/8	2-3/16	1-7/16	3/4	2-1/4	1-7/8	1-3/4	1/2	1/2	1-3/4-12	1-14	8-1/16	3/16	7-1/4	3-3/8

FLUOROCARBON SEALS for operation to 250°F are available at extra cost. Specify model PLV or KPLV.



For inventory, lead times, and kit lookup, visit [www.pdnplu.com](http://www.pdnplu.com)

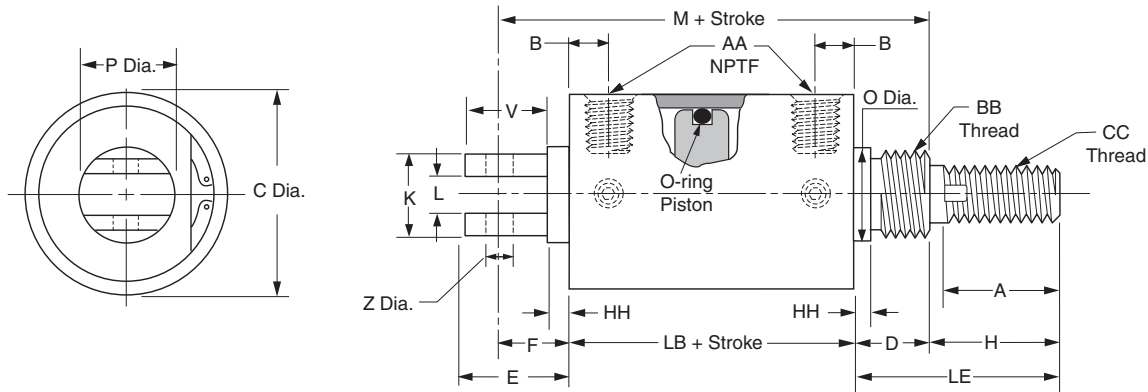
C62

**Parker Hannifin Corporation**  
 Pneumatic Division  
 Richland, Michigan  
[www.parker.com/pneumatics](http://www.parker.com/pneumatics)

Round Body Pneumatic Cylinders  
 SR/SRM/SRD/SRDM Series  
 SRG/SRGM Series  
 SRX Series  
 P1A Series  
 P Series

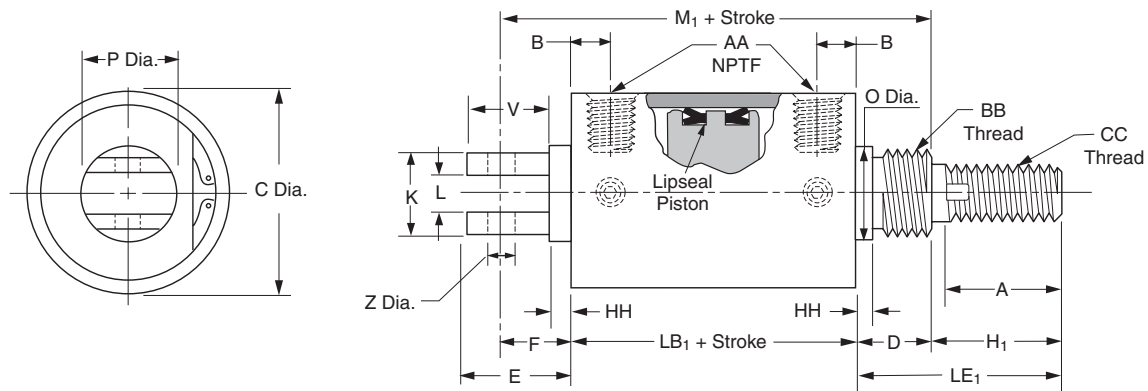
**Model AP**

O-ring piston – single rod  
 1-1/8" bore thru 3" bore



**Model APL**

Lipseal piston – single rod  
 1-1/8" bore thru 4" bore



Mounting nuts not supplied with cylinder.

**Models AP and APL only**

Bore Size	Rod Dia.	LB	LB <sub>1</sub>	B	C	D	E	F	H	H <sub>1</sub>	A	K	L	M	M <sub>1</sub>	O	P	V	Z	AA	BB	CC	HH	LE	LE <sub>1</sub>	
1-1/8	3/8	2-1/16	3-1/16	13/32	1-3/8	5/8	1	11/16	1	1	7/8	15/16	3/8	4-3/8	5-3/8	3/4	15/16	7/8	3/8	1/8	3/4-16	3/8-16	3/32	1-5/8	1-5/8	
1-1/2	1/2	2-5/8	3-5/8	1/2	1-3/4	7/8	1-5/8	15/16	2-7/16	1-7/16	1-1/4	1-1/4	1/2	6-7/8	6-7/8	1-1/16	1-1/4	1-1/2	3/8	1/4	1-14	1/2-13	1/8	3-5/16	2-5/16	
2	5/8	2-5/8	3-5/8	1/2	2-1/4	7/8	2-1/4	1-9/16	2-7/16	1-7/16	1-1/4	1-1/2	1/2	7-1/2	7-1/2	1-1/16	1-11/16	1-3/4	1/2	1/4	1-14	5/8-11	1/8	3-5/16	2-5/16	
2-1/2	3/4	3	4	5/8	2-3/4	1	2-1/4	1-13/16	1-1/8	3-11/16	2-11/16	1-1/2	1-1/2	1/2	8-13/16	8-13/16	1-3/8	2-1/4	1-11/16	1/2	3/8	1-3/8-12	3/4-10	3/16	4-11/16	3-11/16
3	3/4	3	4	5/8	3-1/4	1	2-5/8	1-5/8	3-11/16	2-11/16	1-1/2	1-1/2	1/2	9-5/16	9-5/16	1-3/8	2-1/4	1-3/4	1/2	3/8	1-3/8-12	3/4-10	3/16	4-11/16	3-11/16	
4	1	-	5-1/2	15/16	4-3/8	1-1/8	2-7/8	1-7/8	-	2-1/4	1-7/8	2-1/4	3/4	-	10-3/4	1-3/4	3	2-1/2	3/4	1/2	1-3/4-12	1-14	3/16	-	3-3/8	

FLUOROCARBON Seals for operation to 250°F are available at extra cost. Specify model ASPV or ASPLV.

  
 Round Body  
 Pneumatic Cylinders  
 SR/SRM/SRD/SRDM  
 Series  
 SRG/SRGM  
 Series  
 SRX  
 Series  
 P1A  
 Series  
 P  
 Series



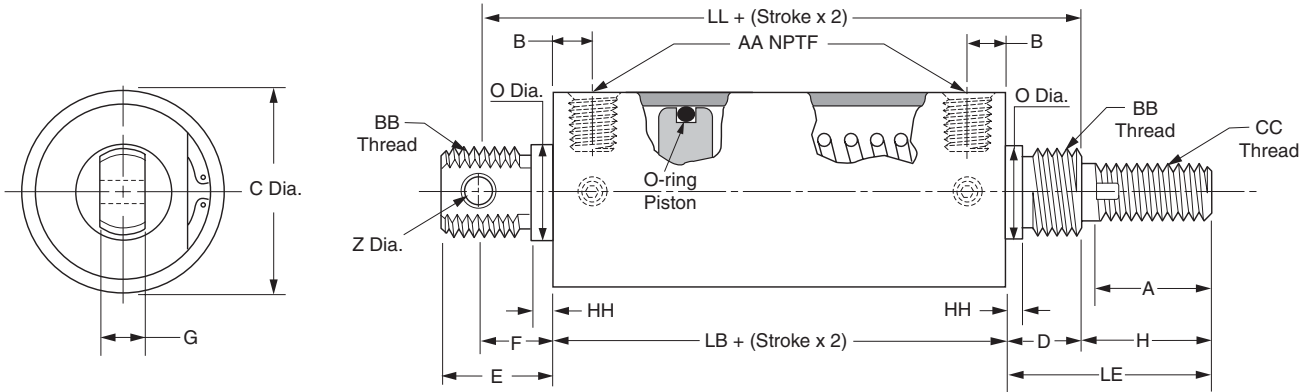
For inventory, lead time, and kit lookup, visit [www.pdnplu.com](http://www.pdnplu.com)

C63

**Parker Hannifin Corporation**  
 Pneumatic Division  
 Richland, Michigan  
[www.parker.com/pneumatics](http://www.parker.com/pneumatics)

**Model PR – Spring return**  
**Model PE – Spring extend**

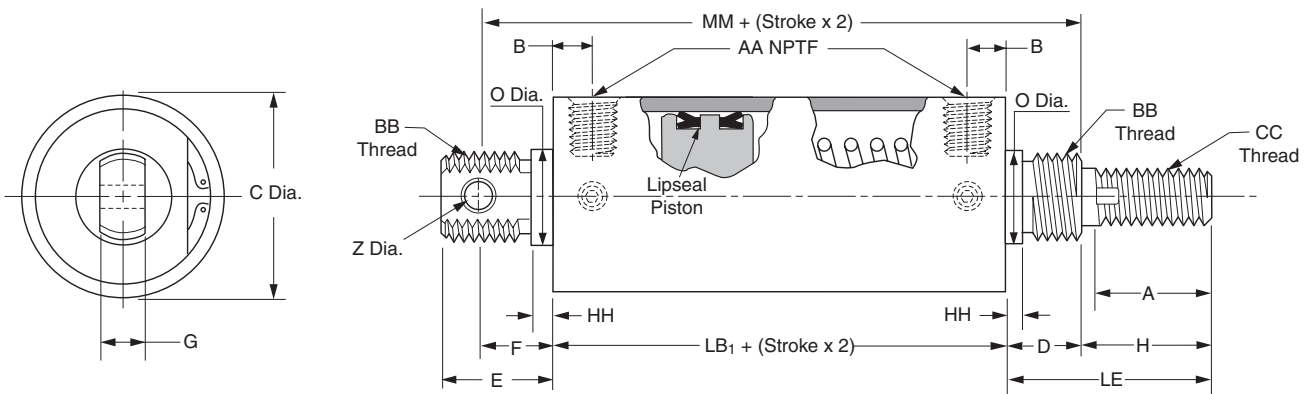
O-ring piston



Spring return cylinders are available without tail section covered by dimension E minus HH at no extra charge. To order, add letter "N" to model number.

**Model PLR – Spring return**  
**Model PLE – Spring extend**

Lipseal piston



Mounting nuts not supplied with cylinder.

**For single rod spring return cylinders up to 6" stroke (no load spring)**

Bore Size	Rod Dia.	LB	LB <sub>1</sub>	B	C	D	E	F	G	H	A	O	Z	AA	BB	CC	HH	LL	MM	LE	Spring force	
																					Pre-load (lbs.)	Max. load (lbs.)
1-1/8	3/8	2-1/16	3-1/16	13/32	1-3/8	5/8	1	11/16	3/8	1	7/8	3/4	1/4	1/8	3/4-16	3/8-16	3/32	3-3/8	4-3/8	1-5/8	12	36
1-1/2	1/2	2-5/8	3-5/8	1/2	1-3/4	7/8	1-1/4	7/8	1/2	1-7/16	1-1/4	1-1/16	5/16	1/4	1-14	1/2-13	1/8	4-3/8	5-3/8	2-5/16	14	45
2	5/8	2-5/8	3-5/8	1/2	2-1/4	7-8	1-1/4	7/8	1/2	1-7/16	1-1/4	1-1/16	5/16	1/4	1-14	5/8-11	1/8	4-3/8	5-3/8	2-5/16	18	48
2-1/2	3/4	3	4	5/8	2-3/4	1	2	1-3/8	5/8	1-11/16	1-1/2	1-3/8	7/16	3/8	1-3/8-12	3/4-10	3/16	5-3/8	6-3/8	2-11/16	30	64
3	3/4	3	4	5/8	3-1/4	1	2	1-3/8	5/8	1-11/16	1-1/2	1-3/8	7/16	3/8	1-3/8-12	3/4-10	3/16	5-3/8	6-3/8	2-11/16	30	64
4	1	▲	5-1/2	15/16	4-3/8	1-1/8	2-3/16	1-7/16	3/4	2-1/4	1-7/8	1-3/4	1/2	1/2	1-3/4-12	1-14	3/16	▲	8-1/16	3-3/8	50	148

▲ 4" bore spring return cylinders, available only with lipseal type piston.

\*\* Net stroke plus stop tube = gross stroke.

FLUOROCARBON SEALS for operation to 250°F are available at extra cost. Specify model PVR, PVE, PLVR or PLVE.

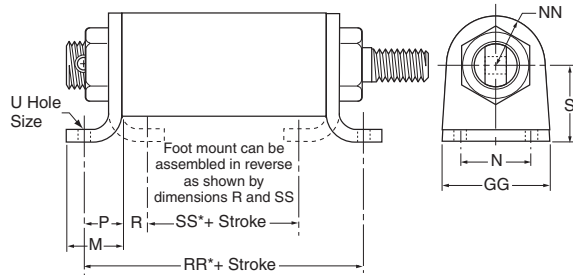
\* Dimensions shown are for cylinder with no load spring. For heavier springs or double rod spring return cylinders, consult factory.



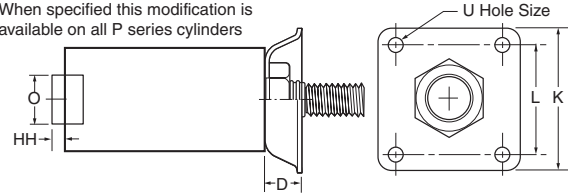
For inventory, lead times, and kit lookup, visit [www.pdnplu.com](http://www.pdnplu.com)



**Foot and Flange Mounts**



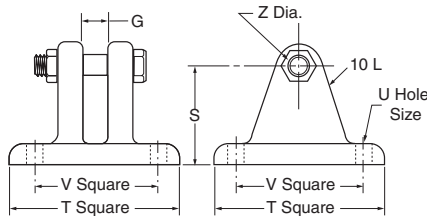
No tang type shown.  
 When specified this modification is available on all P series cylinders



Bore size	D	K	L	M	N	O	P	R	S	U	GG	HH	NN	RR	SS	Foot mount*	Flange mount**
1-1/8	5/8	2-1/2	2	1-3/8	1-11/16	3/4	7/8	5/8	1-9/32	9/32	2-11/16	3/32	11/16	3-13/16	13/16	L069190000	L069230000
1-1/2	7/8	3-1/4	2-1/2	1-9/32	1-5/8	1-1/16	7/8	9/16	1-3/4	9/32	2-7/16	1/8	1-1/8	4-3/8	1-1/2	L069200000	L069240000
2	7/8	3-1/4	2-1/2	1-9/32	1-5/8	1-1/16	7/8	9/16	1-3/4	9/32	2-7/16	1/8	1-1/8	4-3/8	1-1/2	L069200000	L069240000
2-1/2	1	4-1/2	3-3/8	1-29/32	2-1/4	1-3/8	1-1/4	7/8	2-3/8	13/32	3-9/16	3/16	1-5/8	5-1/2	1-1/4	L069210000	L069250000
3	1	4-1/2	3-3/8	1-29/32	2-1/4	1-3/8	1-1/4	7/8	2-3/8	13/32	3-9/16	3/16	1-5/8	5-1/2	1-1/4	L069210000	L069250000
4	1-1/8	5-1/4	4	2-17/32	3-1/4	1-3/4	1-3/4	1-5/16	3-3/16	15/32	4-13/16	3/16	2-3/16	9▲	2-7/8▲	L069220000	L069260000

▲ Dimension shown is for lipseal piston type.  
 \* Part number includes one foot mounting and one mounting nut.  
 \*\* Includes mounting nut.

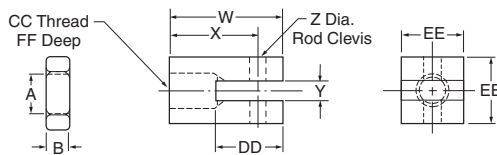
**Clevis Bracket**



Bore size	G	S	T	U	V	Z	Part number
1-1/8	3/8	1-9/32	2-1/4	9/32	1-3/4	1/4	L067300000
1-1/2	1/2	1-3/4	3	9/32	2-1/4	5/16	L067310000
2	1/2	1-3/4	3	9/32	2-1/4	5/16	L067310000
2-1/2	5/8	2-3/8	4	13/32	3	7/16	L067320000
3	5/8	2-3/8	4	13/32	3	7/16	L067320000
4	3/4	3-3/16	5	15/32	3-3/4	1/2	L067330000

Connecting pin and locknut furnished with clevis bracket.

**Rod Clevis**

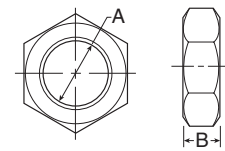


Cyl. bore	Rod dia.	A	B	CC	DD	EE	FF	W	X	Y	Z	Part number
1-1/8	3/8	3/8-16	7/32	3/8-16	1-1/8	3/4	5/8	1-3/4	1-3/8	5/16	1/4	L067340000
1-1/2	1/2	1/2-13	5/16	1/2-13	1-5/16	1	15/16	2-1/4	1-3/4	3/8	5/16	L067350000
2	5/8	5/8-11	3/8	5/8-11	1-5/16	1	15/16	2-1/4	1-3/4	3/8	5/16	L067360000
2-1/2	3/4	3/4-10	27/64	3/4-10	1-5/16	1-1/4	1-1/16	2-3/8	1-13/16	1/2	7/16	L067370000
3	3/4	3/4-10	27/64	3/4-10	1-5/16	1-1/4	1-1/16	2-3/8	1-13/16	1/2	7/16	L067370000
4	1	1-14	35/64	1-14	1-13/16	1-1/2	1-9/16	3-3/8	2-5/8	5/8	1/2	L067380000

Note: Rod end jam nut furnished with rod clevis.

Most popular.

**Mounting Nut for Cylinders\*\***



Bore size	A	B	Part number
1-1/8	3/4-16	27/64	0833010048
1-1/2 & 2	1-14	35/64	0833010100
2-1/2 & 3	1-3/8-12	25/32	0833010124
4	1-3/4-12	15/16	0831830000

**Sensors**

See section L for sensors.

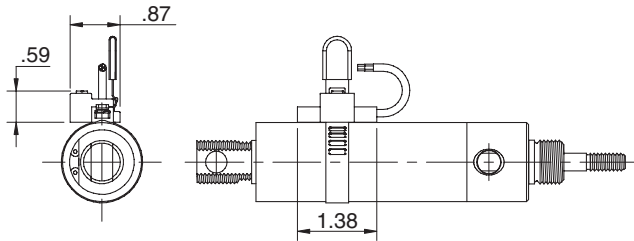


For inventory, lead time, and kit lookup, visit [www.pdnplu.com](http://www.pdnplu.com)

C65

**Parker Hannifin Corporation**  
 Pneumatic Division  
 Richland, Michigan  
[www.parker.com/pneumatics](http://www.parker.com/pneumatics)

**Sensors**



**How To Order P Series Sensors**

P Series sensors are not mounted to the cylinder prior to shipment. When ordering a cylinder to accommodate a P Series sensor:

1. Derive a proper cylinder number as shown on the Ordering Information page and include magnet, option "M" in Seals/Option Code.
2. As a separate item specify the number of sensors required.\*
3. As a third item specify the quantity of the proper clamp assembly.\*

\* For information regarding sensors, please refer to the Electronic Sensors section.

**Example:**

To order a 1-1/2" x 6" cylinder with P Series sensors to sense the end of stroke at both head and cap end.

Item	Qty.	Description
A	(2)	P8S-GPSHX Sensor
B	(2)	P8S-TMC02 Clamp Assembly

Bore	Piston Travel at Mid Stroke* (Sensor Activated)
1-1/8"	0.33
1-1/2"	0.37
2"	0.49
2-1/2"	0.44
3"	0.40
4"	0.33

\* Sensing distance at "End of Stroke" can be adjusted from 'mid-stroke' sensing distance to zero. For sensor specifications and part numbers, see Electronic Sensors section.

† Piston travel ±.01".

**Service Kits**

**Table A**

**Seal kit for series "P" cylinders with o-ring piston**

Contains: 2 each symbol #15 & 1 each symbol #16, 24 & 25

Bore size	Standard seal kit part number	Hi-temp seal kit part number
1-1/8"	L067680000	L067730000
1-1/2"	L067690000	L067740000
2"	L067700000	L067750000
2-1/2"	L067710000	L067760000
3"	L067720000	L067770000

**Table B**

**Seal kit for series "P" cylinders with lipseal piston**

Contains: 2 each symbol #15 & 23 & 1 each symbol #24 & 25

Bore size	Standard seal kit part number	Hi-temp seal kit part number
1-1/8"	L067780000	L067840000
1-1/2"	L067790000	L067850000
2"	L067800000	L067860000
2-1/2"	L067810000	L067870000
3"	L067820000	L067880000
4"	L067830000	L067890000

**Table C**

**Cushion seal kit for series "P" cylinders**

Contains: 2 each symbol #19 & 21 (Symbol #21 not required or supplied for 1-1/8" & 1-1/2" bore size cylinders)

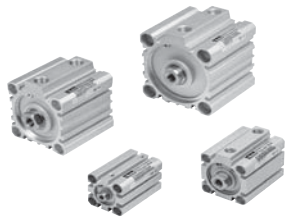
Bore size	Standard seal kit part number	Hi-temp seal kit part number
1-1/8"	L067900000	L067950000
1-1/2"	L067910000	L067960000
2"	L067920000	L067970000
2-1/2"	L067930000	L067980000
3"	L067930000	L067980000
4"	L067940000	L067990000

Round Body Pneumatic Cylinders  
 SR/SRM/SRD/SRDM Series  
 SRG/SRGM Series  
 SRX Series  
 P1A Series  
 P Series



For inventory, lead times, and kit lookup, visit [www.pdnplu.com](http://www.pdnplu.com)

**Compact Design  
Pneumatic Cylinders**



**P1Q Series - Economy**

Features	D2
Ordering Information	D3
Specifications	D4
Dimensional Data	D5-D6
Accessories	D7-D9

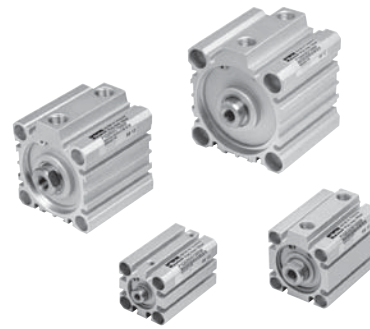
**LP / LPM Series - Low Profile**

Features	D10-D11
Ordering Information	D11
Specifications	D12
Technical Data	D13
Dimensional Data	D14-D16
Accessories	D17-D18

Features

P1Q Series

- Economical square body compact cylinder
- 10 bore sizes available 12mm - 100mm
- 4 flexible mounting options
- Female and male rod ends available
- Bumpers standard on all models
- Magnetic and non-magnetic construction available



Operating information

Operating pressure:	10 bar (145 PSIG) maximum
Temperature range:	-5°C to 60°C (23°F to 140°F)
Filtration requirements:	40 micron, dry filtered air

Metric Double Acting / Magnetic - Female Threaded Piston Rod

12mm

Stroke (mm)	Order Code
5	P1QS012DC7G0005
10	P1QS012DC7G0010
15	P1QS012DC7G0015
25	P1QS012DC7G0025
30	P1QS012DC7G0030

16mm

5	P1QS016DC7G0005
10	P1QS016DC7G0010
15	P1QS016DC7G0015
25	P1QS016DC7G0025
30	P1QS016DC7G0030

20mm

10	P1QS020DC7G0010
15	P1QS020DC7G0015
25	P1QS020DC7G0025
30	P1QS020DC7G0030
40	P1QS020DC7G0040
50	P1QS020DC7G0050

25mm

10	P1QS025DC7G0010
15	P1QS025DC7G0015
25	P1QS025DC7G0025
30	P1QS025DC7G0030
40	P1QS025DC7G0040
50	P1QS025DC7G0050

32mm

10	P1QS032DC7N0010
15	P1QS032DC7N0015
25	P1QS032DC7N0025
30	P1QS032DC7N0030
40	P1QS032DC7N0040
50	P1QS032DC7N0050
75	P1QS032DC7N0075
100	P1QS032DC7N0100

40mm

15	P1QS040DC7N0015
25	P1QS040DC7N0025
30	P1QS040DC7N0030
40	P1QS040DC7N0040
50	P1QS040DC7N0050
75	P1QS040DC7N0075
100	P1QS040DC7N0100

50mm

15	P1QS050DC7N0015
25	P1QS050DC7N0025
30	P1QS050DC7N0030
40	P1QS050DC7N0040
50	P1QS050DC7N0050
75	P1QS050DC7N0075
100	P1QS050DC7N0100

63mm

15	P1QS063DC7N0015
25	P1QS063DC7N0025
30	P1QS063DC7N0030
40	P1QS063DC7N0040
50	P1QS063DC7N0050
75	P1QS063DC7N0075

80mm

15	P1QS080DC7N0015
25	P1QS080DC7N0025
30	P1QS080DC7N0030
40	P1QS080DC7N0040
50	P1QS080DC7N0050
75	P1QS080DC7N0075

100mm

15	P1QS100DC7N0015
25	P1QS100DC7N0025
30	P1QS100DC7N0030
40	P1QS100DC7N0040
50	P1QS100DC7N0050
75	P1QS100DC7N0075

Most popular.

D

Compact  
Pneumatic Cylinders

P1Q  
Series

LP/LPM  
Series

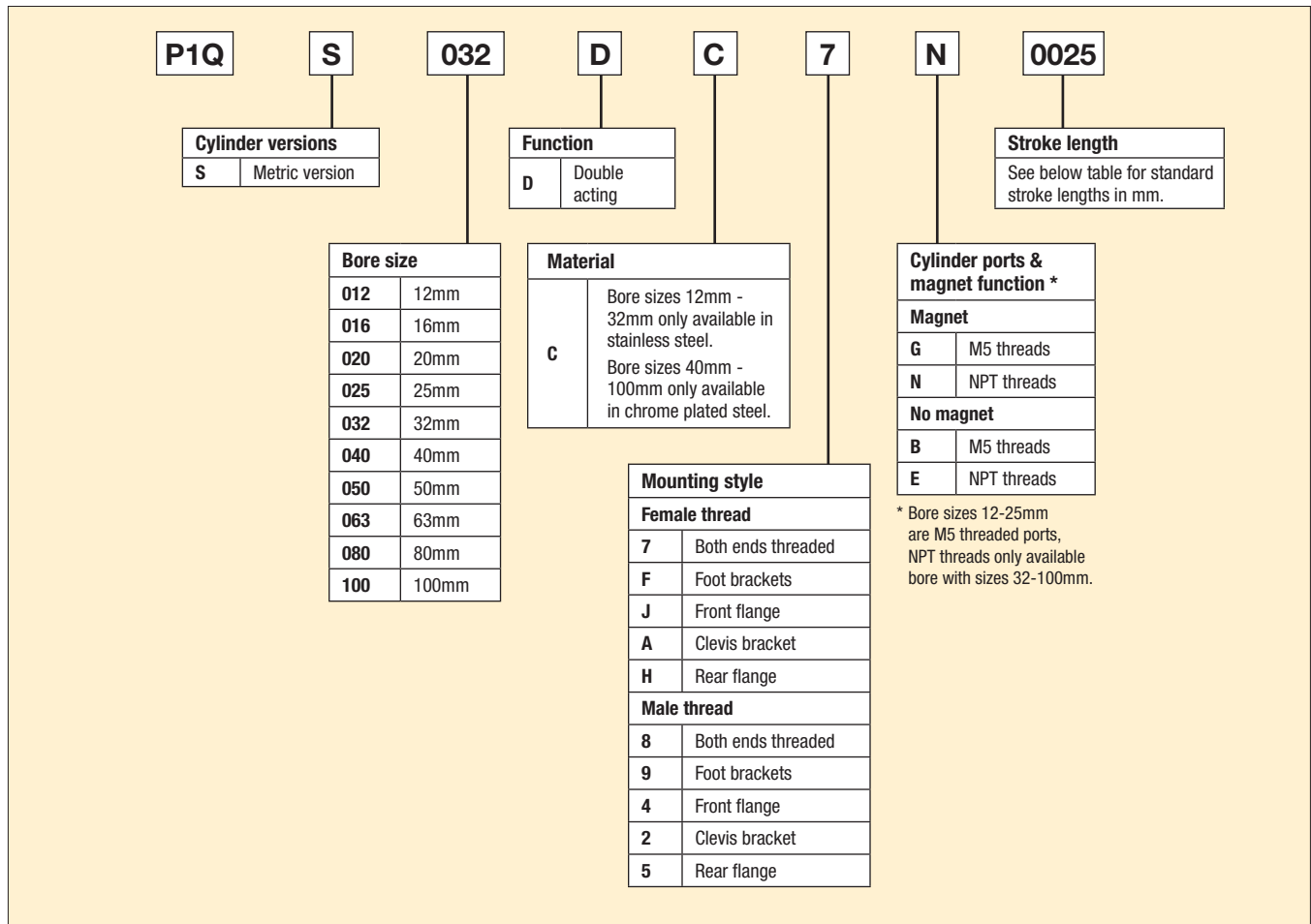


For inventory, lead times, and kit lookup, visit [www.pdnplu.com](http://www.pdnplu.com)

Sensors

See section L for sensors.





**D**  
 Compact Pneumatic Cylinders  
 P1Q Series  
 LP/LPM Series

**Standard strokes**

Bore size	5	10	15	25	30	40	50	75	100
12 - 16	•	•	•	•	•				
20 - 25		•	•	•	•	•	•		
32		•	•	•	•	•	•	•	•
40 - 50			•	•	•	•	•	•	•
63 - 100			•	•	•	•	•	•	



For inventory, lead time, and kit lookup, visit [www.pdnplu.com](http://www.pdnplu.com)

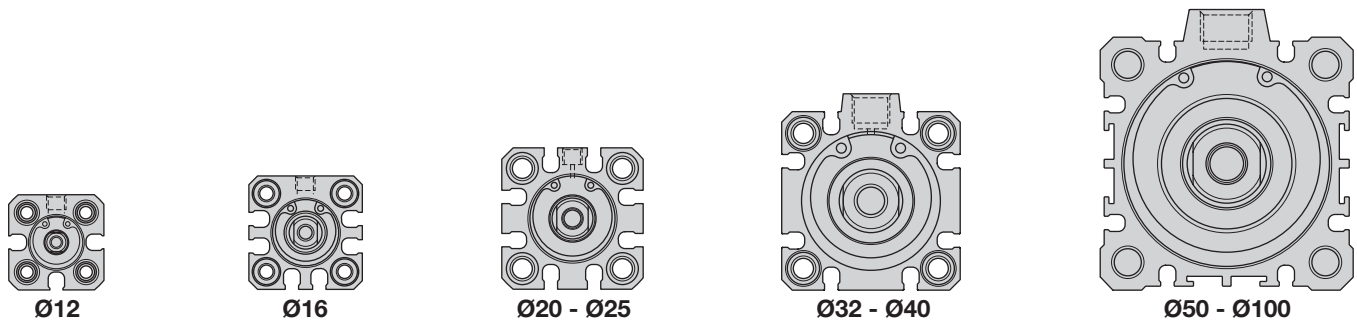
**Cylinder forces, double acting variants**

Cyl. bore/ piston rod mm	Stroke piston area	cm <sup>2</sup>	Max theoretical force in N (bar)								
			1.0	2.0	3.0	4.0	5.0	6.0	7.0	8.0	9.0
12/6	+	1.1	11	23	34	45	57	<b>68</b>	79	90	102
	-	0.8	8	17	25	34	42	<b>51</b>	59	68	76
16/8	+	2.0	20	40	60	80	101	<b>121</b>	141	161	181
	-	1.5	15	30	45	60	75	<b>90</b>	106	121	136
20/10	+	3.1	31	63	94	126	157	<b>188</b>	220	251	283
	-	2.4	24	47	71	94	118	<b>141</b>	165	188	212
25/12	+	4.9	49	98	147	196	245	<b>295</b>	344	393	442
	-	3.8	38	76	113	151	189	<b>227</b>	264	302	340
32/16	+	8.0	80	161	241	322	402	<b>483</b>	563	643	724
	-	6.0	60	121	181	241	302	<b>362</b>	422	483	543
40/16	+	12.6	126	251	377	503	628	<b>754</b>	880	1005	1131
	-	10.6	106	211	317	422	528	<b>633</b>	739	844	950
50/20	+	19.6	196	393	589	785	982	<b>1178</b>	1374	1571	1767
	-	16.5	165	330	495	660	825	<b>990</b>	1155	1319	1484
63/20	+	31.2	312	623	935	1247	1559	<b>1870</b>	2182	2494	2806
	-	28.0	280	561	841	1121	1402	<b>1682</b>	1962	2242	2523
80/25	+	50.3	503	1005	1508	2011	2513	<b>3016</b>	3519	4021	4524
	-	45.4	454	907	1361	1814	2268	<b>2721</b>	3175	3629	4082
100/32	+	78.5	785	1571	2356	3142	3927	<b>4712</b>	5498	6283	7069
	-	70.5	705	1410	2115	2820	3525	<b>4230</b>	4936	5640	6345

+ = Outward stroke  
 - = Return stroke

**Note:**  
 Select a theoretical force 50-100% larger than the force required

**Front profiles by bore size**



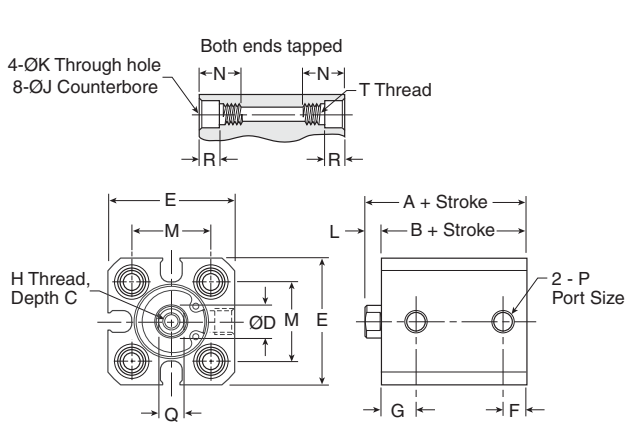
**D**  
 Compact Pneumatic Cylinders  
 P1Q Series  
 LP/LPM Series



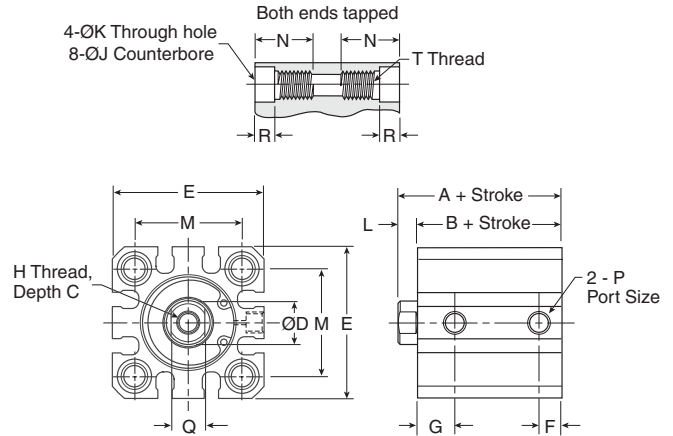
For inventory, lead times, and kit lookup, visit [www.pdnplu.com](http://www.pdnplu.com)

**Magnet**

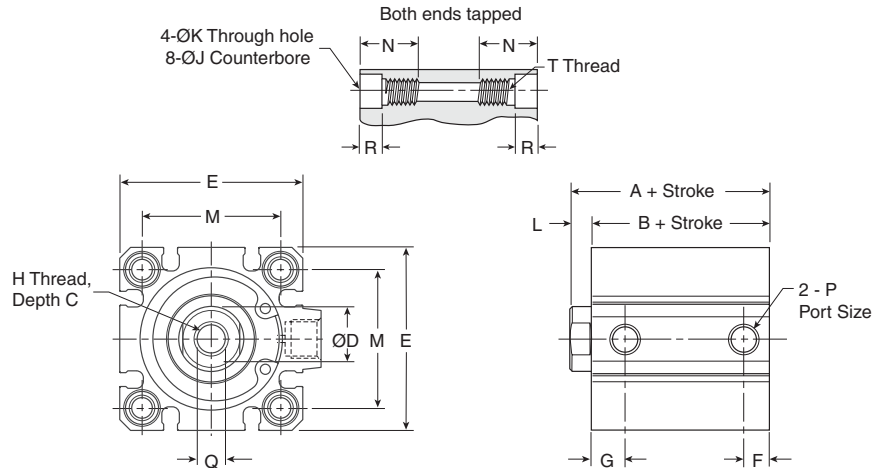
**Ø12 - Ø16**



**Ø20 - Ø25**



**Ø32 - Ø100**



Bore size	A mm	B mm	C mm	D mm	E mm	F mm	G mm	H	J mm	K mm	L mm	M mm	N mm	P	Q mm	R mm	T
12	25.5	22	6	6	25	5	7.5	M3x0.5	6.5	3.5	3.5	15.5	11	M5x0.8	5	4	M4x0.7
16	25.5	22	8	8	29	5	7.5	M4x0.7	6.5	3.5	3.5	20	11	M5x0.8	6	4	M4x0.7
20	34	29.5	7	10	36	5.5	9	M5x0.8	9	5.4	4.5	25.5	17	M5x0.8	8	7	M6x1.0
25	37.5	32.5	12	12	40	5.5	11	M6x1.0	9	5.4	5	28	17	M5x0.8	10	7	M6x1.0
32	40	33	13	16	45	7.5	10.5	M8x1.25	9	5.5	7	34	17	1/8"	14	7	M6x1.0
40	46.5	39.5	13	16	52	8	11	M8x1.25	9	5.5	7	40	17	1/8"	14	7	M6x1.0
50	48.5	40.5	15	20	64	10.5	10.5	M10x1.5	11	6.6	8	50	22	1/4"	17	8	M8x1.25
63	54	46	15	20	77	10.5	15	M10x1.5	14	9	8	60	28.5	1/4"	17	10.5	M10x1.5
80	63.5	53.5	21	25	98	12.5	16	M16x2.0	17.5	11	10	77	35.5	3/8"	22	13.5	M12x1.75
100	75	63	27	30	117	13	23	M20x2.5	17.5	11	12	94	35.5	3/8"	27	13.5	M12x1.75

**D**  
Compact  
Pneumatic Cylinders  
  
P1Q  
Series  
  
LP/LPM  
Series

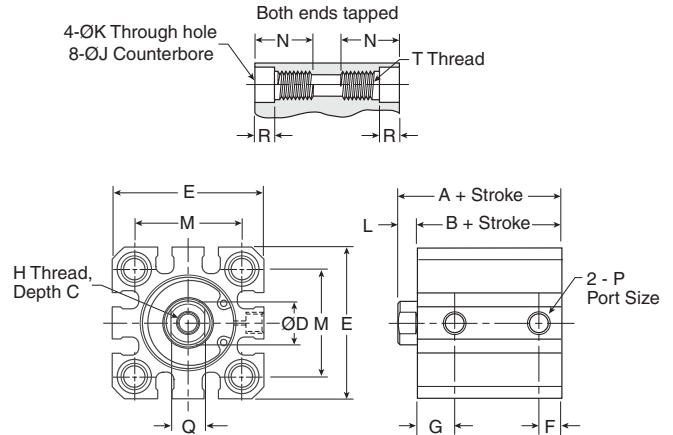
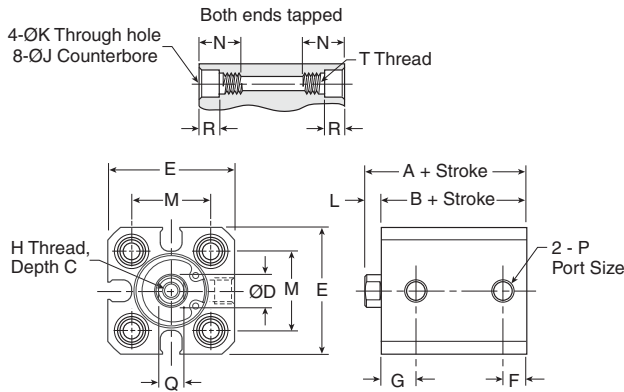


For inventory, lead time, and kit lookup, visit [www.pdnplu.com](http://www.pdnplu.com)

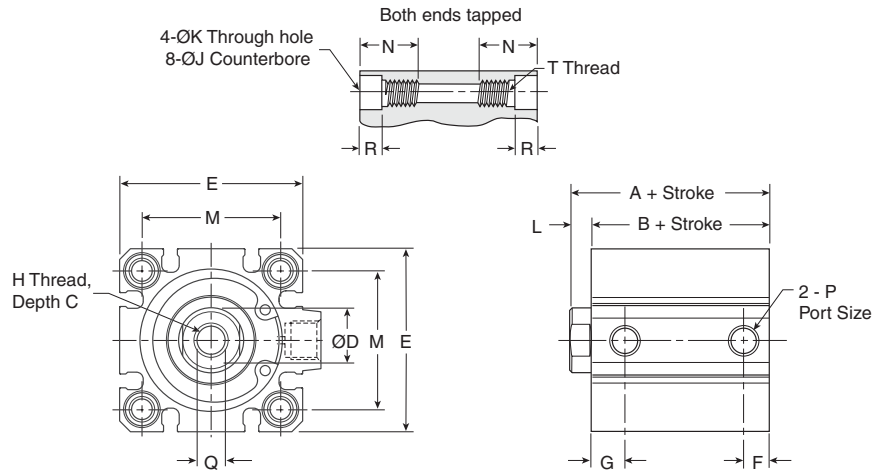
**Non-magnet**

**Ø12 - Ø16**

**Ø20 - Ø25**



**Ø32 - Ø100**



Bore size	A		B		C mm	D mm	E mm	F mm	G mm	H	J mm	K mm	L mm	M mm	N mm	P	Q mm	R mm	T
	5 to 50mm	75 to 100mm	5 to 50mm	75 to 100mm															
12	20.5	-	17	-	6	6	25	5	7.5	M3x0.5	6.5	3.5	3.5	15.5	11	M5x0.8	5	4	M4x0.7
16	20.5	-	17	-	8	8	29	5	7.5	M4x0.7	6.5	3.5	3.5	20	11	M5x0.8	6	4	M4x0.7
20	24	-	19.5	-	7	10	36	5.5	9	M5x0.8	9	5.4	4.5	25.5	17	M5x0.8	8	7	M6x1.0
25	27.5	-	22.5	-	12	12	40	5.5	11	M6x1.0	9	5.4	5	28	17	M5x0.8	10	7	M6x1.0
32	30	40	23	33	13	16	45	7.5	10.5	M8x1.25	9	5.5	7	34	17	1/8"	14	7	M6x1.0
40	36.5	46.5	29.5	39.5	13	16	52	8	11	M8x1.25	9	5.5	7	40	17	1/8"	14	7	M6x1.0
50	38.5	48.5	30.5	40.5	15	20	64	10.5	10.5	M10x1.5	11	6.6	8	50	22	1/4"	17	8	M8x1.25
63	44	54	36	46	15	20	77	10.5	15	M10x1.5	14	9	8	60	28.5	1/4"	17	10.5	M10x1.5
80	53.5	63.5	43.5	53.5	21	25	98	12.5	16	M16x2.0	17.5	11	10	77	35.5	3/8"	22	13.5	M12x1.75
100	65	75	53	63	27	30	117	13	23	M20x2.5	17.5	11	12	94	35.5	3/8"	27	13.5	M12x1.75

**D**  
 Compact Pneumatic Cylinders  
 P1Q Series  
 LP/LPM Series



For inventory, lead times, and kit lookup, visit [www.pdnplu.com](http://www.pdnplu.com)



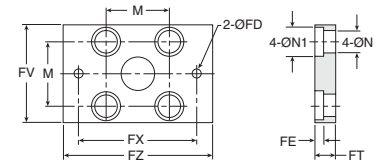
**Flange Mounting – Style J, H, 4, 5**



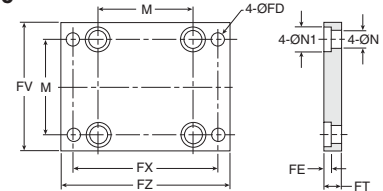
Intended for fixed mounting of cylinder. Flange can be fitted to front or rear of cylinder.

**Material**  
 Flange: surface treated steel, black  
 Supplied complete with mounting screws for attachment to cylinder.

**Ø12 - Ø25**



**Ø32 - Ø100**



Bore size	FD mm	FT mm	FV mm	FX mm	FZ mm	M mm	N mm	N1 mm	Mass kg	Part number
12	4.5	5.5	25	45	55	15.5	4.5	7.5	0.08	<b>P1Q-4DMB</b>
16	4.5	5.5	30	45	55	20	4.5	7.5	0.10	<b>P1Q-4FMB</b>
20	6.5	8	39	48	60	25.5	6.5	10.5	0.16	<b>P1Q-4HMB</b>
25	6.5	8	42	52	64	28	6.5	10.5	0.20	<b>P1Q-4JMB</b>
32	5.5	8	48	56	65	34	6.5	10.5	0.23	<b>P1Q-4KMB</b>
40	5.5	8	54	62	72	40	6.5	10.5	0.28	<b>P1Q-4LMB</b>
50	6.5	9	67	76	89	50	8.5	13.5	0.53	<b>P1Q-4MMB</b>
63	9	9	80	92	108	60	10.5	16.5	0.71	<b>P1Q-4NMB</b>
80	11	11	99	116	134	77	12.5	18.5	1.59	<b>P1Q-4PMB</b>
100	11	11	117	136	154	94	12.5	18.5	2.19	<b>P1Q-4QMB</b>

**Foot Mounting – Style F, 9**

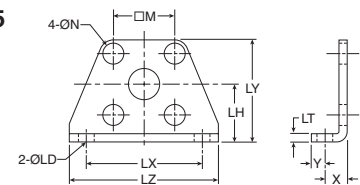


Intended for fixed mounting of cylinder. Angle bracket can be fitted to front and rear of cylinder.

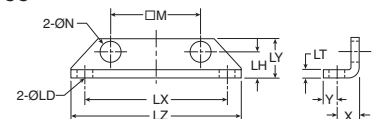
**Material**  
 Angle bracket: surface treated steel, black  
 Supplied in pairs with mounting screws for attachment to cylinder.

\* Weight per item

**Ø12 - Ø25**



**Ø32 - Ø100**



Bore size	LD mm	LH mm	LT mm	LX mm	LY mm	LZ mm	X mm	Y mm	M mm	N mm	Mass kg	Part number
12	4.5	17	2	34	29.5	44	8	4.5	15.5	4.5	0.02*	<b>P1Q-4DMF</b>
16	4.5	19	2	38	33.5	48	8	5	20	4.5	0.02*	<b>P1Q-4FMF</b>
20	6.5	24	3.2	48	42	62	9.2	5.8	25.5	6.5	0.04*	<b>P1Q-4HMF</b>
25	6.5	26	3.2	52	46	66	10.7	5.8	28	6.5	0.05*	<b>P1Q-4JMF</b>
32	6.5	13	3.2	57	20	71	11.2	5.8	34	6.5	0.06*	<b>P1Q-4KMF</b>
40	6.5	13	3.2	64	20	78	11.2	7	40	6.5	0.08*	<b>P1Q-4LMF</b>
50	8.5	14	3.2	79	22	95	12.2	8	50	8.5	0.16*	<b>P1Q-4MMF</b>
63	10.5	16	3.2	95	26	113	13.7	9	60	10.5	0.25*	<b>P1Q-4NMF</b>
80	13	20.5	4.5	118	32	140	16.5	11	77	13	0.50*	<b>P1Q-4PMF</b>
100	13	24	6	137	36	162	23	11.5	94	13	0.85*	<b>P1Q-4QMF</b>

**D**

Compact  
 Pneumatic Cylinders

P1Q  
 Series

LP/LPM  
 Series



For inventory, lead time, and kit lookup, visit [www.pdnplu.com](http://www.pdnplu.com)

D7

**Parker Hannifin Corporation**  
 Pneumatic Division  
 Richland, Michigan  
[www.parker.com/pneumatics](http://www.parker.com/pneumatics)

**Clevis Mounting – Style A, 2**



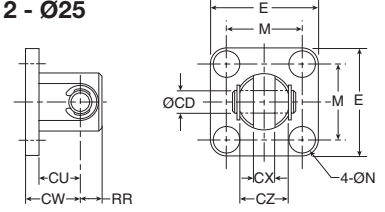
Intended for flexible mounting of cylinder. Clevis bracket can be fitted to the rear of cylinder.

**Material**

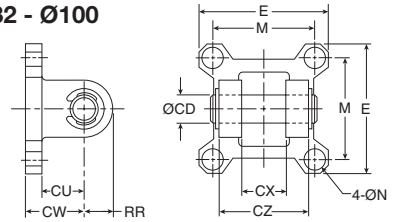
Clevis bracket: surface treated steel, black

Supplied complete with mounting screws for attachment to cylinder.

**Ø12 - Ø25**



**Ø32 - Ø100**



Bore size	CD mm	CU mm	CW mm	CX mm	CZ mm	N mm	RR mm	M mm	E mm	Mass kg	Part number
12	5	9.5	14	5.3	9.8	4.5	6	15.5	25	0.02	<b>P1Q-4DMT</b>
16	5	10.5	15	6.8	11.8	4.5	6	20	29	0.03	<b>P1Q-4FMT</b>
20	8	12.5	18	8.3	15.8	6.5	9	25.5	36	0.05	<b>P1Q-4HMT</b>
25	10	14.5	20	10.3	19.8	6.5	10	28	40	0.06	<b>P1Q-4JMT</b>
32	10	14.5	20	18.3	35.8	6.5	10	34	45.5	0.08	<b>P1Q-4KMT</b>
40	10	15	22	18.3	35.8	6.5	10	40	53.5	0.11	<b>P1Q-4LMT</b>
50	14	20	28	22.3	43.8	8.5	14	50	64.5	0.14	<b>P1Q-4MMT</b>
63	14	21	30	22.3	43.8	10.5	14	60	77.5	0.29	<b>P1Q-4NMT</b>
80	18	28	38	28.3	55.8	12.5	18	77	98.5	0.36	<b>P1Q-4PMT</b>
100	22	32	45	32.3	63.8	12.5	22	94	117.5	0.64	<b>P1Q-4QMT</b>

**Jam Nut**

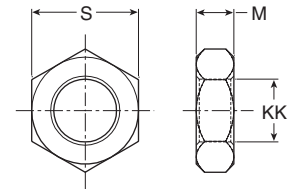


Intended for fixed mounting of accessories to the piston rod.

**Materials**

Galvanized steel

Cylinders supplied with galvanized nut.



Bore size	KK	M	S	Mass kg	Part number
12	M5x0.8	2.7	18	0.002	<b>L075540005</b>
16	M6x1.0	3.2	10	0.002	<b>L075540006</b>
20	M8x1.25	4	13	0.005	<b>L075540008</b>
25	M10x1.25	5	17	0.007	<b>L075540010</b>
32	M14x1.5	7	22	0.010	<b>L075540014</b>
40	M14x1.5	7	22	0.010	<b>L075540014</b>
50	M18x1.5	8	27	0.021	<b>L075540018</b>
63	M18x1.5	8	27	0.021	<b>L075540018</b>
80	M22x1.5	11	32	0.040	<b>L075540022</b>
100	M26x1.5	16	41	0.040	<b>L075540026</b>

**D**  
Compact Pneumatic Cylinders  
P1Q Series  
LP/LPM Series



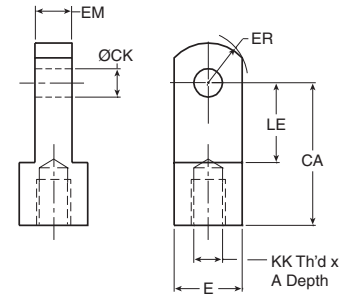
For inventory, lead times, and kit lookup, visit [www.pdnplu.com](http://www.pdnplu.com)

**Rod Eye**



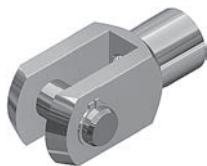
Rod eye for articulated mounting of cylinder.  
 Rod eye can be combined with clevis bracket.  
 Maintenance-free.

**Material**  
 Rod eye, nut: galvanized steel



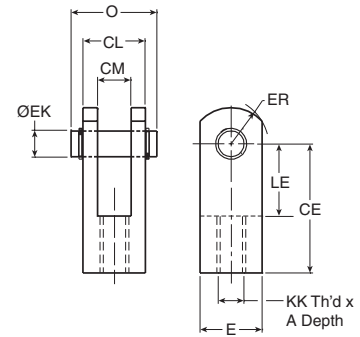
Bore size	A	E	CA	KK	ER	LE	CK	EM	Mass kg	Part number
12	7	9.5 Sq.	16	M5x0.8	6.5	7	5	5	0.03	<b>P1M-4DRE</b>
16	8	11 Sq.	25	M6x1.0	8	14	5	6.5	0.03	<b>P1M-4FRE</b>
20	8.5	16 Sq.	25	M8x1.25	10.5	11.5	8	8	0.05	<b>P1M-4HRE</b>
25	10.5	19 Sq.	30	M10x1.25	13	14	10	10	0.07	<b>P1M-4JRE</b>
32	14	22 Dia.	30	M14x1.5	12	14	10	18	0.08	<b>P1M-4LRE</b>
40	14	22 Dia.	30	M14x1.5	12	14	10	18	0.12	<b>P1M-4LRE</b>
50	18.5	28 Dia.	40	M18x1.5	16	20	14	22	0.25	<b>P1M-4MRE</b>
63	18.5	28 Dia.	40	M18x1.5	16	20	14	22	0.25	<b>P1M-4MRE</b>
80	22	38 Dia.	50	M22x1.5	21	27	18	28	0.25	<b>P1M-4PRE</b>

**Rod Clevis**



Clevis for articulated mounting of cylinder.

**Material**  
 Clevis, clip, nut: galvanized steel  
 Pin: hardened steel



Bore size	A	E	CE	KK	ER	LE	EK (h9)	CM	CL	O	Mass kg	Part number
12	7	9.5	16	M5x0.8	6.5	7	5	5	9.5	14.5	0.02	<b>P1M-4DRC</b>
16	11	11	21	M6x1.0	8	10	5	6.5	11	16.5	0.02	<b>P1M-4FRC</b>
20	8.5	16	25	M8x1.25	10.5	11.5	8	8	16	21	0.05	<b>P1M-4HRC</b>
25	10.5	19	30	M10x1.25	13	14	10	10	19	25.5	0.09	<b>P1M-4JRC</b>
32	16	22 Dia.	30	M14x1.25	12	14	10	18	36	41.5	0.09	<b>P1M-4LRC</b>
40	16	22 Dia.	30	M14x1.25	12	14	10	18	36	41.5	0.15	<b>P1M-4LRC</b>
50	20	28 Dia.	40	M18x1.5	16	20	14	22	44	50.5	0.35	<b>P1M-4MRC</b>
63	20	28 Dia.	40	M18x1.5	16	20	14	22	44	50.5	0.35	<b>P1M-4MRC</b>
80	23	38 Dia.	50	M22x1.5	21	27	18	28	56	64	0.75	<b>P1M-4PRC</b>

**D**  
 Compact Pneumatic Cylinders  
 P1Q Series  
 LP/LPM Series



For inventory, lead time, and kit lookup, visit [www.pdnplu.com](http://www.pdnplu.com)

D9

**Parker Hannifin Corporation**  
 Pneumatic Division  
 Richland, Michigan  
[www.parker.com/pneumatics](http://www.parker.com/pneumatics)

**Features**

**LP/LPM Series**

- Reduces Design Height
- Light Weight
- Reduces Cylinder Overhang
- Specials Available

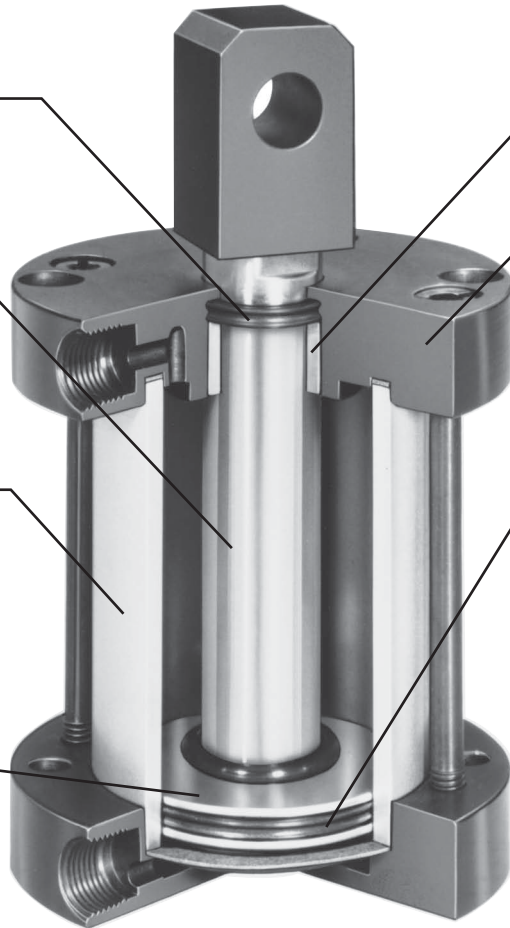
D
Compact Pneumatic Cylinders
P1Q Series
LP/LPM Series

**PISTON ROD SEAL**  
Buna-N quad seal provides positive sealing to keep pressure in and dirt out for less maintenance and trouble free performance.

**PISTON ROD**  
High strength steel, hard chrome plated for reliable smooth performance, long life, and extended seal life.

**CYLINDER BODY**  
Hard coated heavy wall aluminum alloy. The tube I.D. coating has extreme hardness, excellent wear and seizure resistance, low coefficient of friction, and high corrosion resistance. This provides excellent wear qualities and quick break-a-ways.

**PISTON**  
Attached securely to the rod to provide maximum strength and durability.



**ROD BEARING**  
High density iron provides maximum support for longer life.

**HEADS AND CAPS**  
Anodized aluminum alloy for solid, lightweight, high strength performance. This provides excellent corrosion resistance, durability, and a long lasting quality appearance.

**PISTON SEAL**  
Buna-N quad seal provides positive sealing with air.



For inventory, lead times, and kit lookup, visit [www.pdnplu.com](http://www.pdnplu.com)

D10

**Parker Hannifin Corporation**  
Pneumatic Division  
Richland, Michigan  
[www.parker.com/pneumatics](http://www.parker.com/pneumatics)

Features

- Low profile design
- Flexible construction with special modification capability
- High density iron rod bearing provides maximum support for longer life
- Single and double acting versions available
- 6 mounting styles
- 8 bore sizes from 9/16" to 4"
- Strokes from 1/8" to 6"
- Permanent lubrication
- Non-lube service



Operating information

Operating pressure:	200 PSIG (17 bar)	
Temperature range:	LP	-10°F to 200°F (-23°C to 93°C)
	LPM	-10°F to 140°F (-23°C to 60°C)
Filtration requirements:	40 micron, dry filtered air	

Ordering information

<b>1.50</b> <b>Bore size</b> 0.56 9/16" 0.75 3/4" 1.12 1-1/8" 1.50 1-1/2" 2.00 2" 2.50 2-1/2" 3.00 3" 4.00 4"	<b>K</b> <b>Double rod cylinder</b> Blank Single rod K Double rod	<b>N</b> <b>Mounting style</b> N Basic (Std.) <b>Single rod styles</b> 4F Head bolt 4R Cap bolt 2F Head trunnion <sup>1</sup> 2R Cap trunnion <sup>1</sup> 1 Cap pivot eye <b>Double rod styles</b> N Basic 4R Cap bolt 2F Head trunnion <b>Hollow rod styles</b> <sup>1,2,5</sup> NH Basic 4RH Cap bolt 2FH Head trunnion	<b>LP</b> <b>Series</b> LP Standard LPM Magnetic Piston <sup>5</sup> <b>Piston seal</b> Blank Standard seal L Lipseal piston seal <sup>3</sup>	<b>L</b> <b>Seals</b> Blank Standard V Class 5 seals	<b>V</b> <b>Bumpers*</b> Blank No bumpers B Bumpers both ends H Head end only <sup>6</sup> C Cap end only <sup>4</sup> <small>* Please reference page D13 for stroke reduction.</small>	<b>B</b> <b>Spring</b> Blank None E Spring extended R Spring return	<b>E</b> <b>Special features</b> Blank No special feature S Special feature	<b>S</b> <b>Stroke length</b> Specify stroke length required in inches.	<b>9</b> <b>Rod end thread style</b> 9 Standard female rod end 4 Optional male rod end 3 Special rod end (specify dimensions or sketch)	<b>1.25"</b>
--	--	--	--	---	---	---	--	---	---	--------------

**Sensors**  
See section L for sensors.

For ordering purposes, when special options or common modifications are requested, the factory will assign a sequential part number in place of the model number.

**D**  
 Compact Pneumatic Cylinders  
 P1Q Series  
 LP/LPM Series



For inventory, lead time, and kit lookup, visit [www.pdnplu.com](http://www.pdnplu.com)

**General Specifications**

- Low Profile Design
- 6 Mounting Styles
- 8 Bore Sizes from 9/16" to 4"
- Temperature Range: -10°F to 200°F  
 (LPM Series 140°F max.)
- Strokes from 1/8" to 6"
- Permanent Lubrication
- Maximum Operating Pressure: 145 PSI Air

**D**  
**Compact Pneumatic Cylinders**  
**P1Q Series**  
**LP/LPM Series**

**Push/Pull Forces**

Bore dia.	Rod area	Piston area Push/Pull		PSI									
				40	50	60	80	100	125	150	175	200	250
9/16	0.048	Push	0.248	10	12.5	15	20	25	31	37	43	50	62
		Pull	0.200	8	10	12	16	20	25	30	35	40	50
3/4	0.076	Push	0.442	17.5	22	26.5	35	44	55	66	77	88	111
		Pull	0.366	14.6	18	22	29	37	46	55	64	73	92
1-1/8	0.196	Push	0.994	40	50	60	80	99	124	149	174	200	249
		Pull	0.798	32	40	48	64	80	100	120	140	160	200
1-1/2	0.307	Push	1.767	71	88	106	141	177	221	265	309	353	443
		Pull	1.460	58	73	88	117	146	182	219	256	292	365
2	0.442	Push	3.141	126	157	188	251	314	393	471	550	628	785
		Pull	2.699	108	135	162	216	270	337	405	472	540	675
2-1/2	0.442	Push	4.908	196	245	294	393	491	613	736	859	982	1227
		Pull	4.466	178	223	268	357	447	558	670	781	893	1116
3	.601	Push	7.069	283	353	424	566	707	884	1060	1237	1414	1767
		Pull	6.468	259	324	389	519	649	811	973	1135	1297	1622
4	0.781	Push	12.57	503	628	754	1006	1257	1571	1885	2200	2514	3142
		Pull	11.79	471	589	707	942	1178	1484	1767	2062	2356	2945

**Weights – Basic Cylinders**

Bore dia.	Basic N mount weight in ounces*	Add per 1/8" of stroke (ounces)
9/16	1.1	0.08
3/4	2.0	0.1
1-1/8	5.0	0.2
1-1/2	8.5	0.4
2	11.7	0.5
2-1/2	18.6	0.6
3	25.1	0.7
4	51.1	1.1

\* Base weight includes 1/8 inch of stroke.

**Tie Rod Torque**

Bore	Torque (inch pounds)
9/16	8 - 10
3/4	20 - 25
1-1/8	20 - 25
1-1/2	35 - 40
2	35 - 40
2-1/2	50 - 60
3	70 - 80
4	150 - 160



For inventory, lead times, and kit lookup, visit [www.pdnplu.com](http://www.pdnplu.com)

## Technical Data

### Noise Dampening Bumpers

Bumpers both ends – B  
 Bumpers rod end – R  
 Bumper cap end – C\*

Bumpers are available at either or both ends of the cylinder to reduce noise for quieter operation. Bumper material is a 70 durometer nitrile.

The table shows the distance the stroke is reduced when incorporating bumpers. This varies with operating pressure as indicated in the table.

**Example:** 1.50 NL PB9 x 0.50" stroke. Bumpers both ends cylinder will have a working stroke of 0.43" instead of 0.50" operating at 80 psi. For special applications call the factory.

#### NOTES:

Bumpers shorten actual strokes and are not practical on short stroke with low operating pressure.

Bumpers on Cap End or Both Ends will add the "BC" length in chart to "C" dimension (rod extension).

Bumpers on Double End Cylinders will add the "BR" length in chart to the "C" dimension (rod extension).

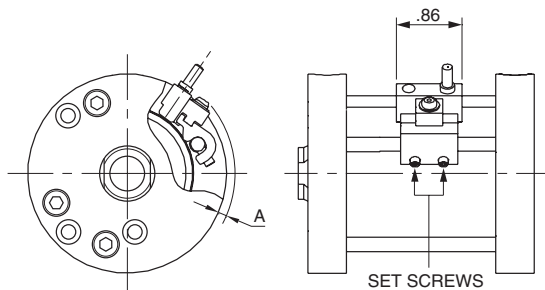
\* Not available on spring extend.

## Compact Pneumatic Cylinders LP/LPM Series

### Stroke Reduction (in.) Using Bumpers

Bore Dia.	Bumper Location	Dim.	Operating Pressure (PSI)					
			0	20	40	60	80	100
0.56	Cap End	BC	0.03	0.02	0.02	0.01	0.01	0.01
	Head End	BR	0.07	0.07	0.06	0.06	0.05	0.04
	Both Ends	BB	0.10	0.09	0.08	0.07	0.06	0.05
0.75	Cap End	BC	0.07	0.07	0.06	0.05	0.05	0.04
	Head End	BR	0.07	0.06	0.05	0.05	0.04	0.03
	Both Ends	BB	0.14	0.13	0.11	0.10	0.09	0.07
1.12	Cap End	BC	0.10	0.09	0.09	0.07	0.07	0.06
	Head End	BR	0.10	0.09	0.08	0.07	0.07	0.06
	Both Ends	BB	0.20	0.18	0.17	0.14	0.14	0.12
1.50	Cap End	BC	0.11	0.10	0.09	0.08	0.07	0.06
	Head End	BR	0.10	0.08	0.08	0.07	0.06	0.06
	Both Ends	BB	0.21	0.18	0.17	0.15	0.13	0.12
2.00	Cap End	BC	0.11	0.09	0.08	0.07	0.06	0.05
	Head End	BR	0.10	0.08	0.06	0.06	0.06	0.05
	Both Ends	BB	0.21	0.17	0.14	0.13	0.12	0.10
2.50	Cap End	BC	0.08	0.06	0.05	0.03	0.03	0.03
	Head End	BR	0.10	0.07	0.06	0.05	0.05	0.04
	Both Ends	BB	0.18	0.13	0.11	0.08	0.08	0.07
3.00	Cap End	BC	0.10	0.06	0.04	0.03	0.02	0.01
	Head End	BR	0.14	0.09	0.08	0.08	0.07	0.07
	Both Ends	BB	0.24	0.15	0.12	0.11	0.09	0.08
4.00	Cap End	BC	0.10	0.08	0.05	0.03	0.03	0.02
	Head End	BR	0.21	0.15	0.13	0.12	0.11	0.11
	Both Ends	BB	0.31	0.23	0.18	0.15	0.14	0.13

### Sensor Mounting Data



To sense piston position, mount sensor along tie rod using 2 each small set screws.

Size	A	Piston Travel at Midstroke (in ±0.01) (Sensor On)	Minimum Activation Distance from End of Stroke (in)	
			Head	Cap
9/16	0.32	0.20	0.13	0.13
3/4	0.25	0.23	0.13	0.13
1-1/8	0.20	0.32	0.13	0.13
1-1/2	0.10	0.32	0.07	0.07
2	0.10	0.35	0.06	0.06
2-1/2	0.03	0.42	0.06	0.06
3	0.03	0.47	0.12	0.12
4	0.00	0.47	0.12	0.12

### Seal Kits

#### Standard Piston

Bore Size	Rod Dia.	Single Rod Cylinders	
		Class 1 Seals Part No.	Class 5 Seals Part No.
9/16	1/4"	SKS05LP251	SKS05LP255
3/4	5/16"	SKS07LP311	SKS07LP315
1-1/8	1/2"	SKS12LP501	SKS12LP505
1-1/2	5/8"	SKS15LP621	SKS15LP625
2	3/4"	SKS20LP751	SKS20LP755
2-1/2	3/4"	SKS25LP751	SKS25LP755
3	7/8"	SKS30LP871	SKS30LP875
4	1"	SKS40LP101	SKS40LP105

#### Lipseal Piston

Bore Size	Rod Dia.	Single Rod Cylinders	
		Class 1 Seals Part No.	Class 5 Seals Part No.
9/16	1/4"	KS05LPL251	KS05LPL255
3/4	5/16"	KS07LPL311	KS07LPL315
1-1/8	1/2"	KS12LPL501	KS12LPL505
1-1/2	5/8"	KS15LPL621	KS15LPL625
2	3/4"	KS20LPL751	KS20LPL755
2-1/2	3/4"	KS25LPL751	KS25LPL755
3	7/8"	KS30LPL871	KS30LPL875
4	1"	KS40LPL101	KS40LPL105



For inventory, lead time, and kit lookup, visit [www.pdnplu.com](http://www.pdnplu.com)

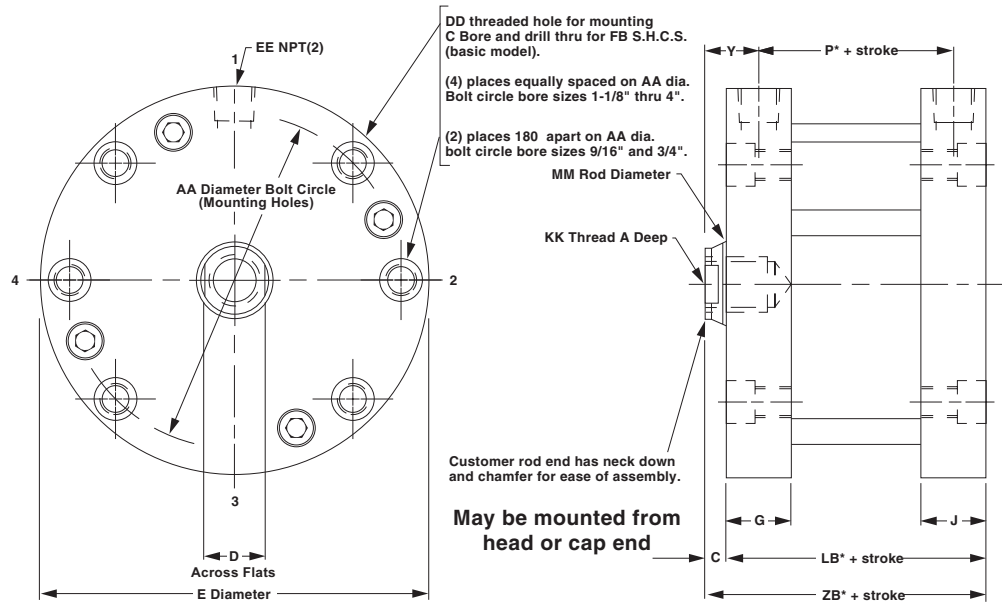
D13

Parker Hannifin Corporation  
 Pneumatic Division  
 Richland, Michigan  
[www.parker.com/pneumatics](http://www.parker.com/pneumatics)

**Mounting Style N**

Cylinder Dimensions  
 Double Acting  
 Single Rod End,  
 Female Rod Style No. 9

Temperature: -10°F  
 to 200°F (optional  
 Fluorocarbon seals).  
 All air cylinders are  
 permanently lubricated.  
 LPM Series maximum  
 temperature 140°F.



Bore size	A	C	D	E	G	J	P*	Y	AA	DD	EE	FB	KK	LB*	MM	ZB*
9/16	0.40	1/8	7/32	1-1/8	23/64	23/64	11/32	17/64	0.875	#8-32	#10-32	#4	#8-32	5/8	1/4	3/4
3/4	0.44	1/8	1/4	1-1/2	23/64	23/64	3/8	17/64	1.219	#10-32	#10-32	#6	#10-32	21/32	5/16	25/32
1-1/8	0.62	1/8	7/16	2	1/2	1/2	27/64	3/8	1.687	#10-32	1/8	#6	5/16-24	59/64	1/2	1-3/64
1-1/2	0.62	1/8	1/2	2-5/8	1/2	1/2	1/2	3/8	2.187	1/4-28	1/8	#10	3/8-24	1	5/8	1-1/8
2	0.70†	1/8	5/8	3-1/8	1/2	1/2	9/16	3/8	2.687	1/4-28	1/8	#10	1/2-20	1-1/16	3/4	1-3/16
2-1/2	0.70†	1/8	5/8	3-3/4	5/8	5/8	5/8	7/16	3.250	5/16-24	1/4	1/4	1/2-20	1-1/4	3/4	1-3/8
3	0.75†	1/8	3/4	4-1/4	43/64	43/64	21/32	7/16	3.781	5/16-24	1/4	1/4	5/8-18	1-9/32	7/8	1-13/32
4	0.75†	1/8	7/8	5-1/2	27/32	27/32	49/64	17/32	4.937	3/8-24	3/8	5/16	3/4-16	1-5/8	1	1-3/4

\* These dimensions are for the LP Series with standard piston.  
 † For strokes less than 0.25", A dimension = 0.66".

**Added length table for LPM or lipseal piston options**

Bore size	LPM option*						LP with lipseal piston option				
	P	LB	XD	XJ	ZB	Stroke	P	LB	XD	XJ	ZB
9/16†	15/16	1-7/32	2	-	1-11/32	1/2	5/8	29/32	1-11/16	-	1-1/32
3/4†	31/32	1-1/4	2-1/32	1-3/16	1-3/8	1/2	21/32	15/16	1-23/32	7/8	1-1/16
1-1/8†	63/64	1-31/64	2-3/8	1-23/64	1-39/64	9/16	43/64	1-11/64	2-1/16	1-3/64	1-19/64
1-1/2	1-1/8	1-5/8	2-13/16	1-1/2	1-3/4	7/16	13/16	1-5/16	2-1/2	1-3/16	1-7/16
2	1-9/32	1-25/32	3-1/32	1-21/32	1-29/32	7/16	61/64	1-29/64	2-45/64	1-21/64	1-37/64
2-1/2	1-21/64	1-61/64	3-21/64	1-3/4	2-5/64	1/2	1	1-5/8	3	1-27/64	1-3/4
3	1-27/64	2-3/64	3-53/64	1-53/64	2-11/64	1/2	1-3/32	1-23/32	3-1/2	1-1/2	1-27/32
4	1-1/2	2-23/64	4-11/64	2	2-31/64	1/2	1-11/64	2-1/32	3-27/32	1-43/64	2-5/32

Note minimum strokes for LPM option.  
 † These bore sizes not available for the LPM option with the hollow rod option.  
 \* The LPM option is only available with the standard quad seal.

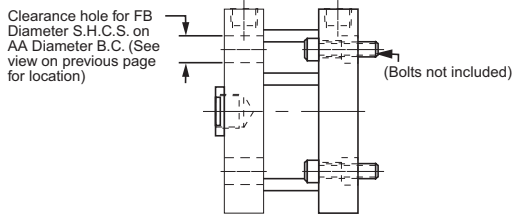


For inventory, lead times, and kit  
 lookup, visit [www.pdnplu.com](http://www.pdnplu.com)



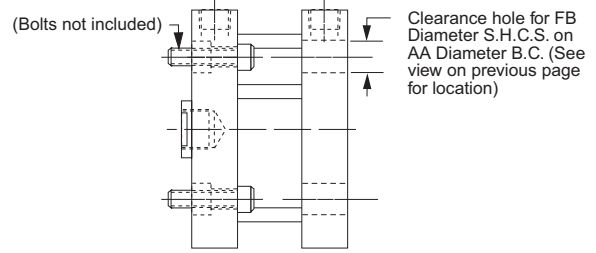
**Head Bolt Clearance Holes**

Mounting Style 4F  
 Available Head End



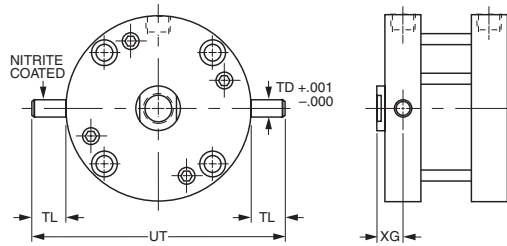
**Cap Bolt Clearance Holes**

Mounting Style 4R  
 Available Cap End



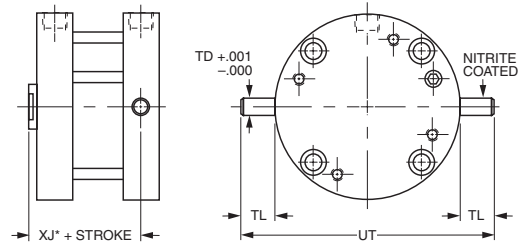
**Head Trunnion**

Mounting Style 2F (9/16" bore not available)



**Cap Trunnion**

Mounting Style 2R (9/16" bore not available)

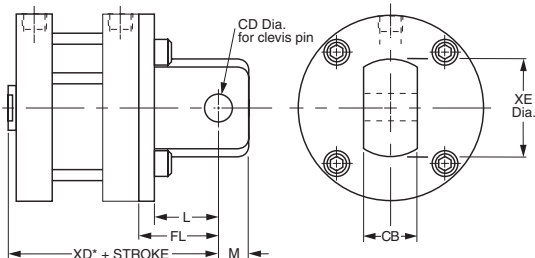


Bore size	TD	TL	UT	XG	XJ*
3/4	0.125	5/16	2-1/8	5/16	19/32
1-1/8	0.250	1/2	3	3/8	51/64
1-1/2	0.250	1/2	3-5/8	3/8	7/8
2	0.250	1/2	4-1/8	3/8	15/16
2-1/2	0.312	5/8	5	29/64	1-3/64
3	0.312	5/8	5-1/2	15/32	1-1/16
4	0.375	3/4	7	35/64	1-17/64

\* These dimensions are for the LP Series with standard piston.

**Cap Pivot Eye**

Mounting Style 1



Bore size	L	M	CB	CD	FL	XD*	XE
9/16	1/2	1/4	3/8	3/16	21/32	1-13/32	19/32
3/4	1/2	1/4	3/8	3/16	21/32	1-7/16	3/4
1-1/8	1/2	1/4	3/8	3/16	49/64	1-13/16	3/4
1-1/2	13/16	7/16	3/4	3/8	1-1/16	2-3/16	1-3/8
2	13/16	7/16	3/4	3/8	1-1/8	2-5/16	1-3/8
2-1/2	13/16	7/16	3/4	3/8	1-1/4	2-5/8	1-3/8
3	1-9/32	9/16	1	5/8	1-21/32	3-1/16	1-7/8
4	1-9/32	9/16	1	5/8	1-11/16	3-7/16	1-7/8

Order clevis pin from accessories when required.

\* These dimensions are for the LP Series with standard piston.

See table on the previous page for dimensions for the lipseal piston or LPM options.



For inventory, lead time, and kit lookup, visit [www.pdnplu.com](http://www.pdnplu.com)

D15

**Parker Hannifin Corporation**  
 Pneumatic Division  
 Richland, Michigan  
[www.parker.com/pneumatics](http://www.parker.com/pneumatics)

## Dimensional Data

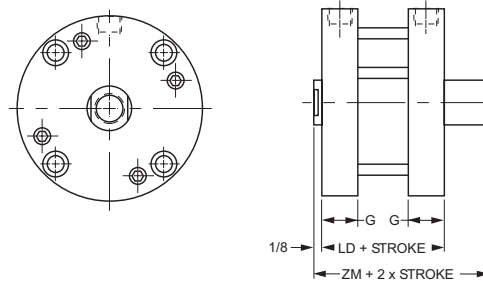
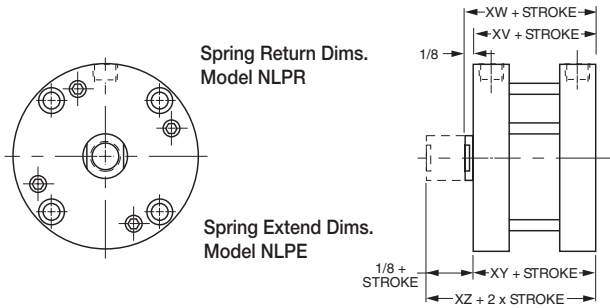
## Compact Pneumatic Cylinders LP/LPM Series

### Spring Extend & Spring Return Cylinders

(Available through 2" stroke)

### Double Rod Spring Extend & Spring Return Cylinders

(Available through 2" stroke)



Bore size	1/8" to 1" stroke				Over 1" to 2" stroke				Add this length to XV, XW, XY, XZ for Lipseal Piston
	XV	XW	XY	XZ	XV	XW	XY	XZ	
9/16	1	1-1/8	57/64	1-1/64	1-11/16	1-13/16	1-37/64	1-45/64	9/32
3/4	1-1/64	1-9/64	59/64	1-3/64	1-45/64	1-53/64	1-39/64	1-47/64	9/32
1-1/8	1-23/64	1-31/64	1-9/32	1-13/32	1-63/64	2-7/64	1-29/32	2-1/32	1/4
1-1/2	1-25/64	1-33/64	1-11/32	1-15/32	2-1/64	2-9/64	1-31/32	2-3/32	5/16
2	1-11/64	1-19/64	1-13/32	1-17/32	1-51/64	1-59/64	2-1/32	2-5/32	25/64
2-1/2	1-3/8	1-1/2	1-23/32	1-27/32	2	2-1/8	2-11/32	2-15/64	3/8
3	1-1/2	1-5/8	1-55/64	1-63/64	2-1/8	2-1/4	2-31/64	2-39/64	7/16
4	1-27/32	1-31/32	2-13/64	2-21/64	2-15/32	2-19/32	2-53/64	2-61/64	13/32

Bore size	Spring return/extend – LP						Spring return/extend – LPM					
	≥ 1/8", ≤ 1"			<1", ≤ 2"			≥ 1/8", >1"			>1", ≤ 2"		
	G	LD	ZM	Min.* stroke	LD	ZM	LD	ZM	Min.* stroke	LD	ZM	
9/16	23/64	1-1/8	1-3/8	5/16	1-13/16	2-1/16	1-23/32	1-27/32	3/16	2-13/32	2-17/32	
3/4	23/64	1-11/64	1-27/64	1/8	1-55/64	2-7/64	1-49/64	1-57/64	3/16	2-29/64	2-37/64	
1-1/8	1/2	1-1/2	1-3/4	1/8	2-1/8	2-3/8	2-1/16	2-3/16	1/8	2-11/16	2-13/16	
1-1/2	1/2	1-11/16	1-15/16	1/8	2-5/16	2-9/16	2-5/16	2-7/16	1/4	2-15/16	3-1/16	
2	1/2	1-31/64	1-47/64	1/8	2-7/64	2-23/64	2-13/64	2-21/64	1/4	2-53/64	2-61/64	
2-1/2	5/8	1-3/4	2	1/8	2-3/8	2-5/8	2-29/64	2-37/64	3/16	3-5/64	3-13/64	
3	43/64	1-29/32	2-5/32	1/8	2-17/32	2-25/32	2-43/64	2-51/64	1/8	3-19/64	3-27/64	
4	27/32	2-1/4	2-1/2	1/8	2-7/8	3-1/8	2-63/64	3-7/64	1/8	3-39/64	3-47/64	

\* Note minimum strokes for LPM option.

### Spring force data

1/8" to 1" stroke			Over 1" to 2" stroke		
Bore size	Max. Spring force (lbs)	Spring rate (lb/in)	Bore dia.	Max. Spring force (lbs)	Spring rate (lb/in)
9/16	5.7	4.25	9/16	5.7	1.75
3/4	9	6	3/4	9	2.5
1-1/8	10	6	1-1/8	10	2.5
1-1/2	13	5.5	1-1/2	12	2.25
2	13	5.5	2	12	2.25
2-1/2	17.5	6	2-1/2	16	2.5
3 & 4	24	6.5	3 & 4	23	2.75



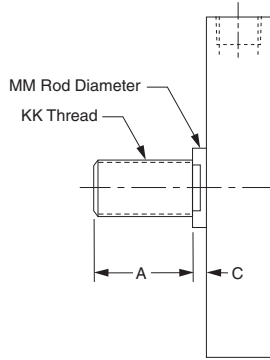
For inventory, lead times, and kit lookup, visit [www.pdnplu.com](http://www.pdnplu.com)

D16

**Parker Hannifin Corporation**  
Pneumatic Division  
Richland, Michigan  
[www.parker.com/pneumatics](http://www.parker.com/pneumatics)

**Optional Male Rod End**

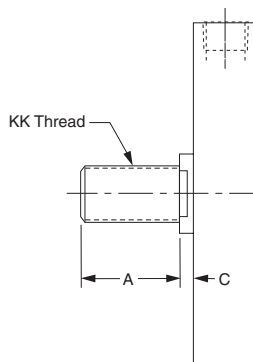
Specify #4



Bore size	A	C	KK	MM
9/16	0.38	1/8	#8-32	1/4
3/4	0.50	1/8	#10-32	5/16
1-1/8	0.50	1/8	5/16-24	1/2
1-1/2	0.50	1/8	3/8-24	5/8
2	0.62	1/8	1/2-20	3/4
2-1/2	0.62	1/8	1/2-20	3/4
3	0.75	1/8	5/8-18	7/8
4	0.75	1/8	3/4-16	1

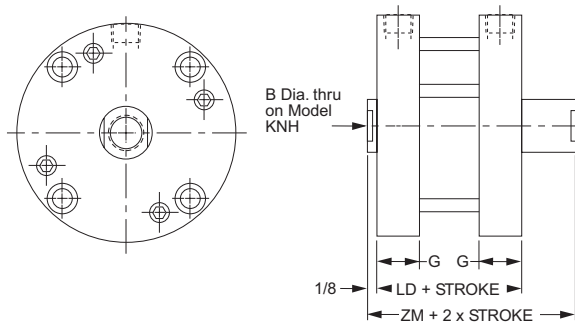
**Non-standard Rods**

For non-standard rod ends, please specify rod thread style 3 and provide the KK, A, and C dimensions as needed.



**Double or Hollow Rod Cylinders**

Note: Cylinders with hollow rod option should not be bottomed out during stroke.



**LP double or hollow rod option, LPM, lipseal piston**

Bore size	B	G	Standard double rod end or with hollow rod		LPM option		LP with lipseal piston option	
			LD	ZM	LD	ZM	LD	ZM
9/16	*	23/64	3/4	1	1-11/32	1-15/32	1-1/32	1-9/32
3/4	9/64	23/64	13/16	1-1/16	1-13/32	1-17/32	1-3/32	1-11/32
1-1/8	7/32	1/2	1-3/16	1-7/16	1-3/4	1-7/8	1-7/16	1-11/16
1-1/2	9/32	1/2	1-19/64	1-35/64	1-59/64	2-3/64	1-39/64	1-55/64
2	3/8	1/2	1-3/8	1-5/8	2-3/32	2-7/32	1-49/64	2-1/64
2-1/2	3/8	5/8	1-5/8	1-7/8	2-21/64	2-29/64	2	2-1/4
3	7/16	43/64	1-11/16	1-15/16	2-29/64	2-37/64	2-1/8	2-3/8
4	1/2	27/32	2-1/32	2-9/32	2-49/64	2-57/64	2-7/16	2-11/16

\*Hollow rod not available on 9/16" bore.

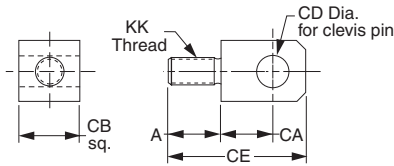


For inventory, lead time, and kit lookup, visit [www.pdnplu.com](http://www.pdnplu.com)

D17

**Parker Hannifin Corporation**  
 Pneumatic Division  
 Richland, Michigan  
[www.parker.com/pneumatics](http://www.parker.com/pneumatics)

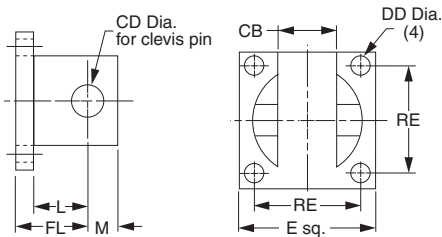
**Rod Eye**



Bore size	A	CA	CB	CD	CE	KK	Part number
9/16	3/8	15/32	3/8	3/16	1-3/32	#8-32	L073810008
3/4	3/8	15/32	3/8	3/16	1-3/32	#10-32	L073810010
1-1/8	9/16	15/32	3/8	3/16	1-9/32	5/16-24	L073810020
1-1/2	5/8	23/32	3/4	3/8	1-25/32	3/8-24	L073810024
2-2-1/2	21/32	23/32	3/4	3/8	1-27/32	1/2-20	L073810032
3	21/32	1	1	5/8	2-3/8	5/8-18	L073810040
4	21/32	1	1	5/8	2-3/8	3/4-16	L073810048

**Clevis Bracket**

(Supplied with Pin)

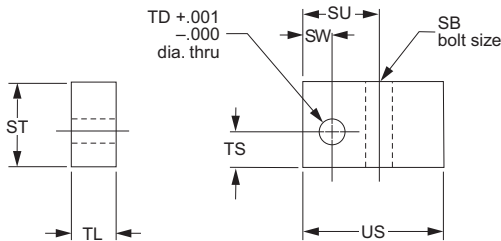


E	L	M	CB	CD	DD	FL	RE	Part number
1	13/32	7/32	25/64	3/16	9/64	9/16	3/4	L073820012
1-3/4	25/32	13/32	49/64	3/8	11/64	15/16	1-3/8	L073820024
2-1/2	1	9/16	1-1/64	5/8	17/64	1-1/4	2	L073820040

Use L073820012 on 9/16", 3/4" and 1-1/8" bore.  
 Use L073820024 on 1-1/2", 2" and 2-1/2" bore.  
 Use L073820040 on 3" and 4" bore.

**Note:** The Clevis Bracket is an accessory for the rod eye or the cap pivot eye and cannot be mounted directly to the cylinder.

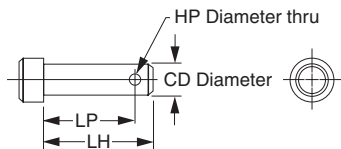
**Trunnion Bracket**



SB	ST	SU	SW	TD	TL	TS	US	Part number
1/4	7/8	13/16	5/16	.252	1/2	3/8	1-1/2	L073840016
5/16	1	15/16	3/8	.314	5/8	29/64	1-5/8	L073840020
3/8	1-1/4	1-1/16	7/16	.377	3/4	35/64	1-7/8	L073840024

Use L073840016 on 1-1/8", 1-1/2" and 2" bore.  
 Use L073840020 on 2- 1/2" and 3" bore.  
 Use L073840024 on 4" bore.

**Clevis Pin**



CD	HP	LH	LP	Part number
3/16	3/32	1	29/32	L073830012
3/8	5/32	1-5/8	1-15/32	L073830024
5/8	5/32	2	1-27/32	L073830040

**Service Kits**

Bore size	Rod dia.	Standard piston, single rod cylinders		Lipseal piston, single rod cylinders	
		Class 1 seals part number	Class 5 seals part number	Class 1 seals part number	Class 5 seals part number
9/16	1/4"	SKS05LP251	SKS05LP255	KS05LPL251	KS05LPL255
3/4	5/16"	SKS07LP311	SKS07LP315	KS07LPL311	KS07LPL315
1-1/8	1/2"	SKS12LP501	SKS12LP505	KS12LPL501	KS12LPL505
1-1/2	5/8"	SKS15LP621	SKS15LP625	KS15LPL621	KS15LPL625
2	3/4"	SKS20LP751	SKS20LP755	KS20LPL751	KS20LPL755
2-1/2	3/4"	SKS25LP751	SKS25LP755	KS25LPL751	KS25LPL755
3	7/8"	SKS30LP871	SKS30LP875	KS30LPL871	KS30LPL875
4	1"	SKS40LP101	SKS40LP105	KS40LPL101	KS40LPL105



For inventory, lead times, and kit lookup, visit [www.pdnplu.com](http://www.pdnplu.com)

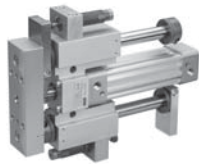
**Guided Design  
Pneumatic Cylinders**

<b>Selection Guide</b>	E2
------------------------	----

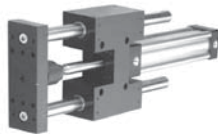
<b>P5T Series</b>	
Features	E3
Ordering Information	E4
Specifications	E5
Engineering Data	E7
Dimensional Data	E15
Options	E16



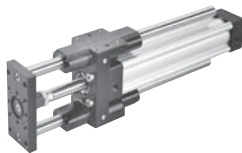
<b>P5L Series - Thrust, Reach, Base</b>	
Features	E22
Ordering Information	E23
Specifications	E24
Engineering Data	E26
Dimensional Data	E53
Options	E56



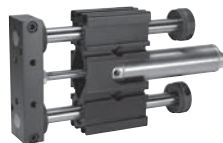
<b>HB Series - Compact, Thrust, Reach, Base</b>	
Features	E72
Ordering Information	E73
Specifications	E74
Engineering Data	E75
Dimensional Data	E83
Options	E87



<b>P5E Series</b>	
Features	E104
Ordering Information	E105
Specifications	E106
Engineering Data	E123
Dimensional Data	E133
Options	E137



<b>XL Series - Thrust, Reach, Base</b>	
<b>XLT &amp; XLR - Thrust &amp; Reach</b>	
Features	E120
Ordering Information	E121
Specifications	E122
Engineering Data	E123
Dimensional Data	E133
Options	E137



<b>XLB - Base</b>	
Features	E145
Ordering Information	E146
Specifications	E147
Engineering Data	E148
Dimensional Data	E153
Options	E155

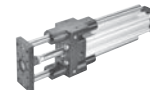
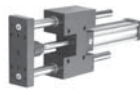
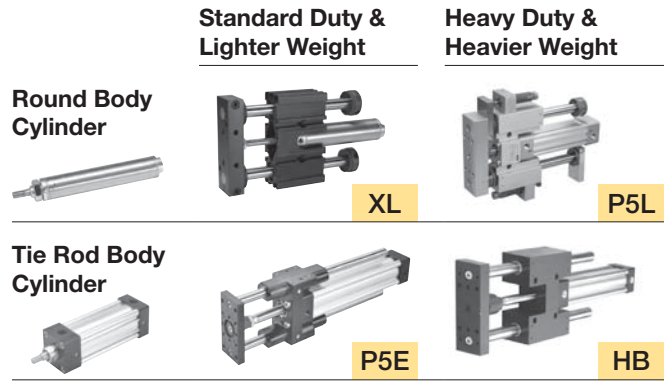
**E**  
Guided  
Cylinders



For inventory, lead time, and kit lookup, visit [www.pdnplu.com](http://www.pdnplu.com)

**Selection Guide**

Basic performance features of the product line are shown below. See catalog sections for greater detail and ordering information. Consult factory for requirements beyond the scope of these guidelines.



Cylinder Type	Built-in	NFFPA/ISO	Round/Tie Rod	ISO	Round
Series	P5T	HB	P5L	P5E	XL
Bore Size Range	16 to 100mm	1½ - 2½ in NFFPA 40 to 63mm ISO	¾ - 3 in Round 32 to 100mm Tie Rod	32 to 100mm	9/16 – 1½ in
Maximum Pressure Rating	10 Bar (145 PSI)	150 PSI	10 Bar (145 PSI)	10 Bar (145 PSI)	6.9 Bar (100 PSI)
Shaft Bearing Type	Composite or Linear Ball Bushings	Composite or Linear Ball Bushings	Composite or Linear Ball Bushings	Composite or Linear Ball Bushings	Composite or Linear Ball Bushings
Non-Lube Service	●	●	●	●	●
Sensor Options	Solid State	●	●	●	●
	Reed	●	●	●	●
	Proximity	●	●	●	●
Mounting Faces	2	4	2	3	4
Mounting Through Holes		●	●		●
Mounting T-Slots			●		●
Stroke Adjustment	●	●	●	●	●
Piston Magnet Standard	●	●	●	●	●
Energy Dissipation	Cushions	●	●	●	C
	Bumpers	●	●	●	●
	Shock Absorbers		●	●	●
Port Relocation	●	●			●
3-Position		●	C	●	●
Rod Lock Option	●	●	●	●	
Hydraulic Service Option		●	C	●	
Alignment Coupler		●		●	●
Fluorocarbon Seals	●	●	●	●	●
Corrosion Resistant	●	●	●	●	●

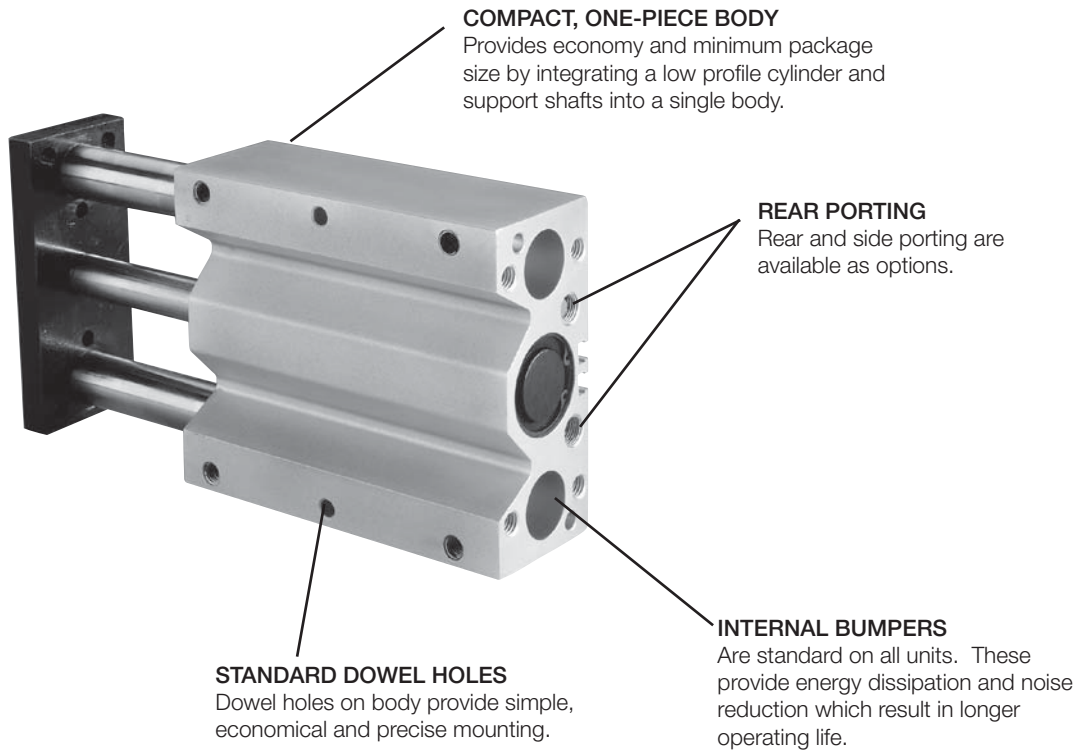
● = Available from catalog  
 C = Consult Factory

**E**  
 Guided  
 Cylinders

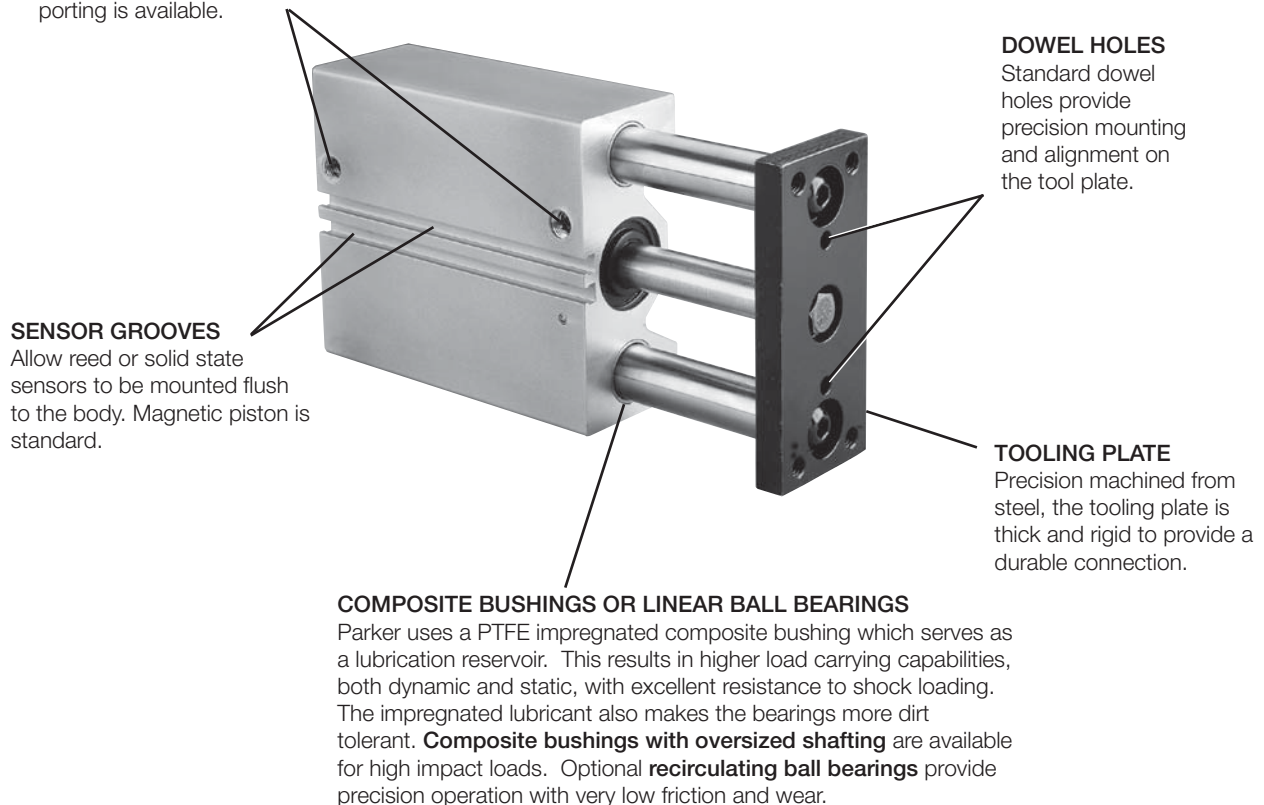


For inventory, lead times, and kit lookup, visit [www.pdnplu.com](http://www.pdnplu.com)

**P5T Series**



**TOP PORTING**  
Top porting is standard. Optional side and rear porting is available.



Guided Cylinders

P5T Series

P5L Series

HB Series

P5E Series

XL Series



For inventory, lead time, and kit lookup, visit [www.pdnplu.com](http://www.pdnplu.com)

E3

**Parker Hannifin Corporation**  
Pneumatic Division  
Richland, Michigan  
[www.parker.com/pneumatics](http://www.parker.com/pneumatics)

Features

- Compact guided cylinder for short stroke applications
- 9 Bore sizes, 16mm to 200mm
- Strokes 10 to 100mm depending on model
- Standard dowel holes on body and tool plate
- High load bearing option
- Internal bumpers and magnetic piston are standard
- Flexible porting: top, rear, side



Operating information

Operating pressure: 1 MPa (145 PSIG / 10 bar)  
 Temperature range:  
 Nitrile seals (standard) 0°F to 165°F (-18°C to 74°C)  
 Fluorocarbon seals\* 0°F to 250°F (-18°C to 121°C)  
 \* See fluorocarbon seal option for high temperature applications.  
 Filtration requirements: 40 micron, dry filtered air

Ordering information

**P5T - J 032 D H S N R 100**

Shaft / bearing type		Bore size		Seals		Stroke length	
<b>J</b>	Composite bearing, chrome plated shaft (std)	<b>016</b>	16mm	<b>S</b>	Nitrile (std)	See table below for standard stroke lengths. Consult factory for special stroke lengths.	
<b>H</b>	Ball bearing, stainless steel shaft	<b>020</b>	20mm	<b>F</b>	Fluorocarbon (high temp)		
<b>C</b>	Composite bearing, stainless steel shaft	<b>025</b>	25mm	<b>Options</b>			
		<b>032</b>	32mm	<b>N</b>	None (std)		
		<b>040</b>	40mm	<b>B</b>	High load bearings <sup>2</sup>		
		<b>050</b>	50mm	<b>A</b>	Bumpers, adjustable stop collars (extend only) and dual tool plate (side ports rec) <sup>3,4</sup>		
		<b>063</b>	63mm	<b>E</b>	Bumpers and adjustable stop collars (extend only) <sup>3</sup>		
		<b>080</b>	80mm	<b>G</b>	High load bearings, bumpers and adjustable stop collars (extend only) <sup>2,3</sup>		
		<b>100</b>	100mm	<b>D</b>	Dual tool plate <sup>3,4</sup>		
				<b>X</b>	Special		

Port location / mounting		Port style		Rod lock and stroke type	
<b>D</b>	Dowel holes, top ports (std)	<b>H</b>	NPTF (std)	<b>Blank</b>	Standard stroke (std hsg), or special stroke (custom hsg)
<b>R</b>	Dowel holes, rear ports, top plugged (std)	<b>G</b>	BSPP	<b>R</b>	Standard stroke (std hsg) with rod lock
<b>S</b>	Dowel holes, side ports <sup>1</sup> and top ports	<b>P</b>	Flow control, BSPP port, prestolok tube (mm) <sup>1</sup>	<b>T</b>	Special stroke (std hsg) <sup>5</sup>
		<b>F</b>	Flow control, NPTF port, prestolok tube (inch) <sup>1</sup>	<b>B</b>	Special stroke (std hsg) with rod lock <sup>5</sup>
		<b>B</b>	Flow control, BSPP <sup>1</sup>		
		<b>N</b>	Flow control, NPTF <sup>1</sup>		

Standard strokes (mm)*										
Bore size (mm)	10	25	40	50	75	100	125	150	175	200
16	•	•	•	•	•	•				
20		•	•	•	•	•				
25		•		•	•	•	•			
32 - 100		•		•	•	•	•	•	•	•

\* Consult factory for special stroke lengths.

**NOTES:**  
<sup>1</sup> Cannot combine flow controls, side ports and 25mm stroke.  
<sup>2</sup> Not available with rear mounting and ports.  
<sup>3</sup> Not available with rear port location (R).  
<sup>4</sup> Includes high load bearings as standard.  
<sup>5</sup> Dimensions for special stroke length actuators will be the same as those of the next longest stroke actuator.

**Sensors**  
 See section L for sensors.

**P**  
Guided Cylinders

P5T Series

P5L Series

HB Series

P5E Series

XL Series



For inventory, lead times, and kit lookup, visit [www.pdnplu.com](http://www.pdnplu.com)



## General Specifications

### Specifications

- Maximum operating pressure: 1 MPa (10 bar/145 psi)
  - Operating characteristics: Double acting
  - Support rod sizes: ø8 to 35mm
  - Mounting: Unrestricted
  - Operating temperature range (cylinder):
    - Nitrile seals (standard) -18° to 74°C (0° to 165°F)
    - Fluorocarbon seals\* -18° to 121°C (0° to 250°F)
  - Filtration requirement: 40 micron, filtered dry air
- \* See Fluorocarbon seal option for high temperature applications.

### Construction

Body	Aluminum
End Caps	Aluminum
Tool Plate	Steel
Piston Rod	Stainless Steel
Support Rods	Steel (Chrome Plated)
Rod Bolts	Steel

### Quick Reference Data

Model (bore size)	Piston rod (mm)	Bushings	Support rods (mm)	Piston bore area non-rod side		Max stroke (mm)	Theoretical force			
				mm <sup>2</sup>	in <sup>2</sup>		Extend @75 PSI (0.5 MPa)		Retract @75 PSI (0.5 MPa)	
							N	lb	N	lb
16	8	Ball	8	200	0.31	100	105	23.6	77.4	17.4
		Composite	10	200	0.31	100	105	23.6	77.4	17.4
20	10	Ball	10	316	0.49	125	164	36.8	123	27.8
		Composite	12	316	0.49	125	164	36.8	123	27.8
25	10	Ball	12	490	0.76	150	254	57	213.5	48
		Composite	16	490	0.76	150	254	57	213.5	48
32	16	Ball	16	804	1.25	200	402	93	302	70
		Composite	20	804	1.25	200	402	93	302	70
40	16	Ball	16	1257	1.95	200	628	146	528	123
		Composite	20	1257	1.95	200	628	146	528	123
50	20	Ball	20	1964	3.04	200	982	228	825	192
		Composite	25	1964	3.04	200	982	228	825	192
63	20	Ball	20	3117	4.83	200	1559	362	1492	326
		Composite	25	3117	4.83	200	1559	362	1492	326
80	25	Ball	25	5027	7.79	200	2513	584	2268	527
		Composite	30	5027	7.79	200	2513	584	2268	527
100	25	Ball	30	7854	12.17	200	3927	913	3574	856
		Composite	35	7854	12.17	200	3927	913	3574	856

## Guided Pneumatic Cylinders P5T Series

### Mounting Bolts

Bore size	Socket head cap
16	M5 x .8
20	M5 x .8
25	M6 x 1.0
32	M8 x 1.25
40	M8 x 1.25
50	M10 x 1.5
63	M10 x 1.5
80	M12 x 1.75
100	M14 x 2.0

Note: When the P5T is used as an impact stopping system, mounting bolt thread engagement should be 1.5 times bolt diameter.



Guided  
Cylinders

P5T  
Series

P5L  
Series

HB  
Series

P5E  
Series

XL  
Series



For inventory, lead time, and kit lookup, visit [www.pdnplu.com](http://www.pdnplu.com)

**Weights**

**P5T Series**

**Units with Composite Bushings**


Weights in kg (lb)

Model	Standard stroke (mm)									
	10	25	40	50	75	100	125	150	175	200
16	0.35 (0.77)	0.43 (0.95)	0.51 (1.13)	0.57 (1.25)	0.70 (1.54)	0.84 (1.84)	-	-	-	-
20	-	0.76 (1.66)	0.86 (1.90)	0.94 (2.06)	1.11 (2.45)	1.29 (2.85)	1.47 (3.24)	-	-	-
25	-	1.13 (2.48)	-	1.39 (3.05)	1.65 (3.63)	1.91 (4.20)	2.17 (4.77)	2.43 (5.35)	-	-
32	-	1.67 (3.68)	-	2.07 (4.55)	2.46 (5.42)	2.86 (6.29)	3.26 (7.17)	3.65 (8.04)	4.05 (8.91)	4.45 (9.78)
40	-	2.00 (4.40)	-	2.42 (5.32)	2.84 (6.25)	3.26 (7.17)	3.68 (8.10)	4.10 (9.02)	4.52 (9.94)	4.84 (10.65)
50	-	2.63 (5.78)	-	3.22 (7.08)	3.81 (8.38)	4.40 (9.69)	4.99 (10.99)	5.59 (12.29)	6.18 (13.59)	6.77 (14.89)
63	-	3.29 (7.24)	-	3.98 (8.75)	4.66 (10.25)	5.34 (11.75)	6.02 (13.25)	6.71 (14.76)	7.39 (16.26)	8.07 (17.76)
80	-	6.06 (13.33)	-	7.12 (15.66)	8.18 (18.00)	9.24 (20.33)	10.30 (22.66)	11.36 (24.99)	12.42 (27.33)	13.48 (29.66)
100	-	10.69 (23.52)	-	12.03 (26.47)	13.37 (29.42)	14.71 (32.37)	16.05 (35.32)	17.39 (38.27)	18.73 (41.22)	20.08 (44.17)

**Units with Linear Ball Bushings**

Weights in kg (lb)

Model	Standard Stroke (mm)									
	10	25	40	50	75	100	125	150	175	200
16	0.32 (0.70)	0.39 (0.86)	0.46 (1.02)	0.51 (1.13)	0.64 (1.40)	0.76 (1.67)	-	-	-	-
20	-	0.70 (1.53)	0.80 (1.75)	0.86 (1.90)	1.03 (2.26)	1.19 (2.62)	1.36 (2.99)	-	-	-
25	-	0.98 (2.15)	-	1.20 (2.64)	1.43 (3.14)	1.65 (3.64)	1.88 (4.14)	2.11 (4.63)	-	-
32	-	1.51 (3.31)	-	1.86 (4.09)	2.21 (4.86)	2.56 (5.63)	2.91 (6.41)	3.27 (7.18)	3.62 (7.96)	3.97 (8.73)
40	-	1.82 (4.01)	-	2.20 (4.83)	2.57 (5.66)	2.95 (6.49)	3.32 (7.31)	3.70 (8.14)	4.08 (8.97)	4.45 (9.79)
50	-	2.35 (5.17)	-	2.87 (6.32)	3.39 (7.47)	3.92 (8.62)	4.44 (9.76)	4.96 (10.91)	5.48 (12.06)	6.01 (13.21)
63	-	2.99 (6.58)	-	3.60 (7.93)	4.22 (9.28)	4.83 (10.63)	5.45 (11.98)	6.06 (13.33)	6.67 (14.68)	7.29 (16.03)
80	-	5.66 (12.45)	-	6.63 (14.59)	7.61 (16.74)	8.58 (18.88)	9.56 (21.03)	10.53 (23.18)	11.51 (25.32)	12.49 (27.47)
100	-	10.16 (22.36)	-	11.40 (25.09)	12.64 (27.82)	13.89 (30.55)	15.13 (33.28)	16.37 (36.01)	17.61 (38.74)	18.85 (41.46)


**Guided Cylinders**  
 P5T Series  
 P5L Series  
 HB Series  
 P5E Series  
 XL Series

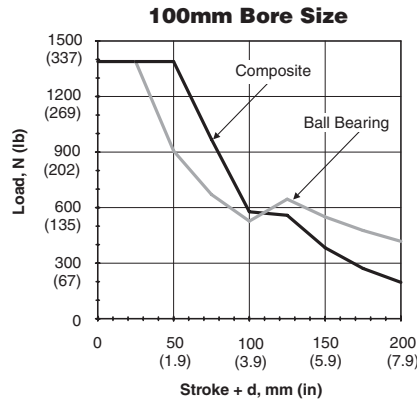
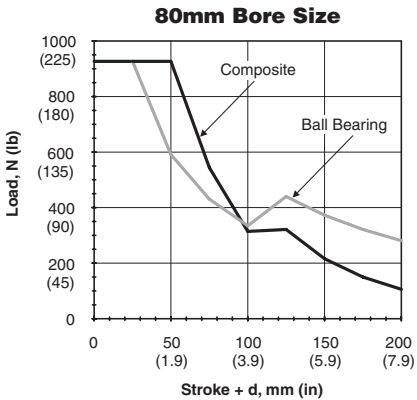
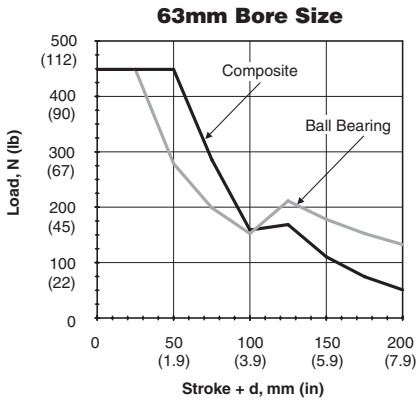
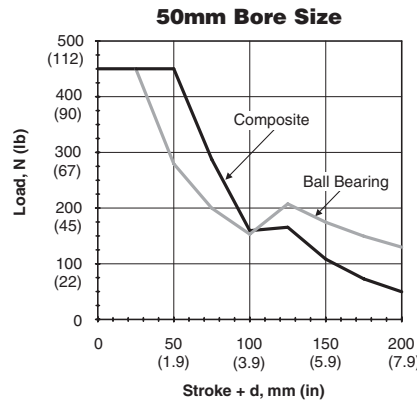
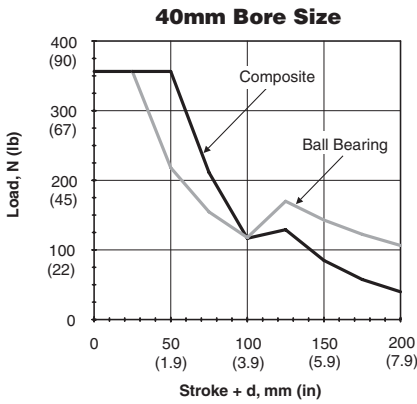
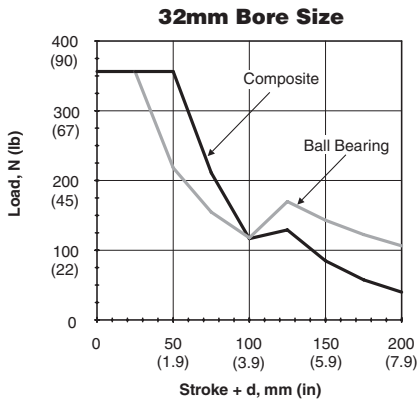
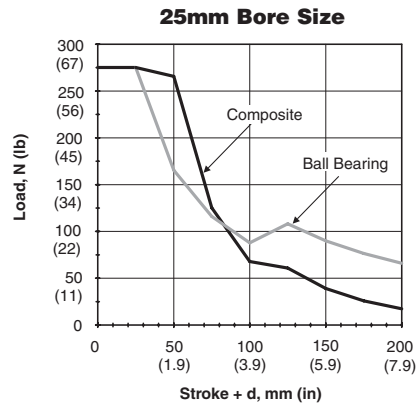
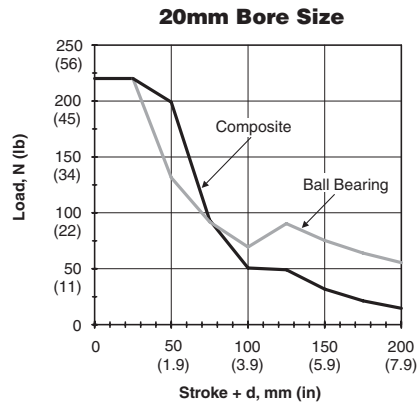
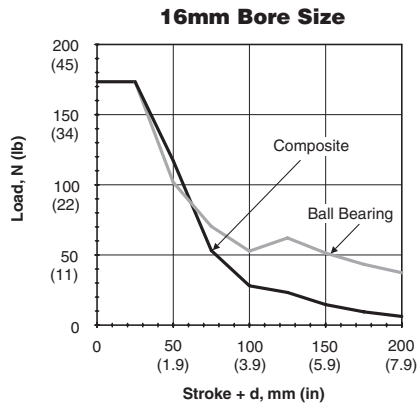
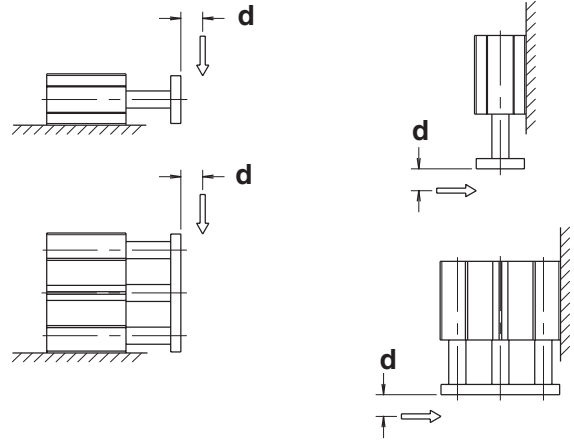


For inventory, lead times, and kit lookup, visit [www.pdnplu.com](http://www.pdnplu.com)

**Horizontal Load Capacity  
Standard Unit**

P5T Series units will have the same load capacity regardless of orientation. The graphs below show maximum load capacity based on a unit life of 10 million cycles.

**EXAMPLE:** A P5T-16 with “stroke + d” of 75mm and composite bushings would have a load capacity of 50N.



<b>M</b>	Guided Cylinders
P5T Series	
P5L Series	
HB Series	
P5E Series	
XL Series	

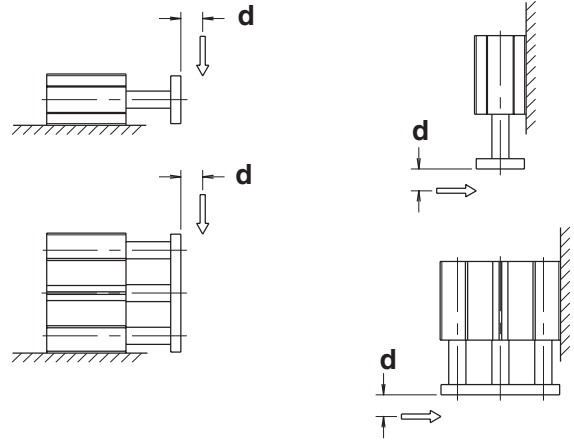


For inventory, lead time, and kit lookup, visit [www.pdnplu.com](http://www.pdnplu.com)

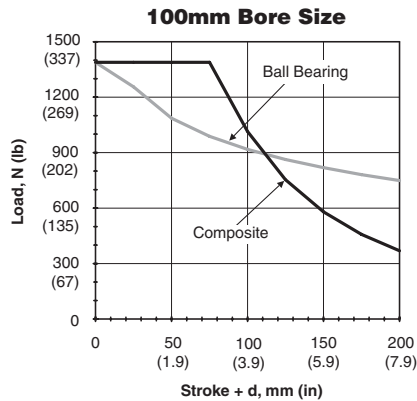
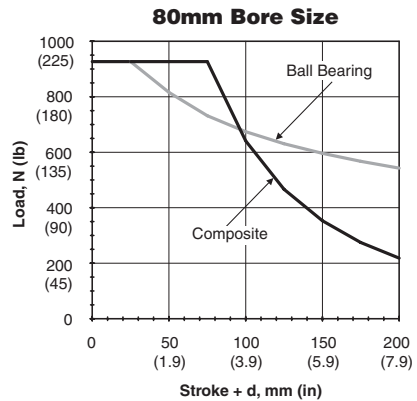
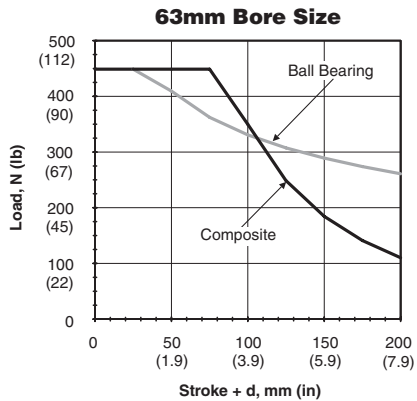
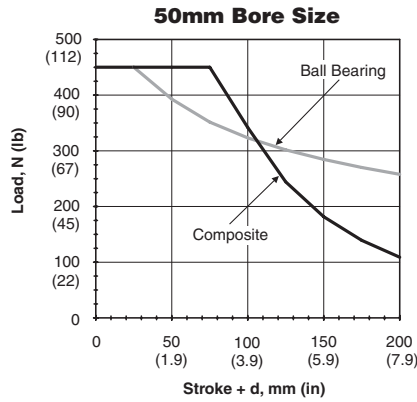
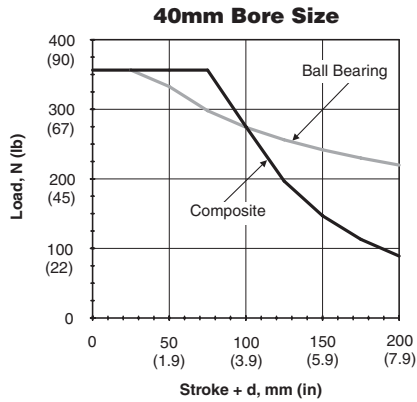
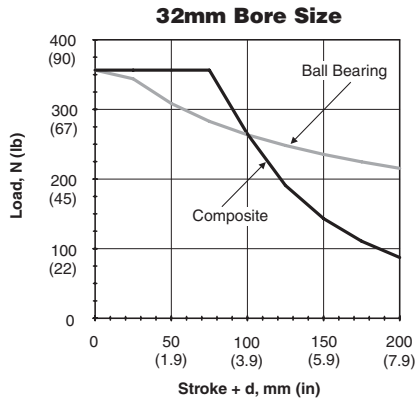
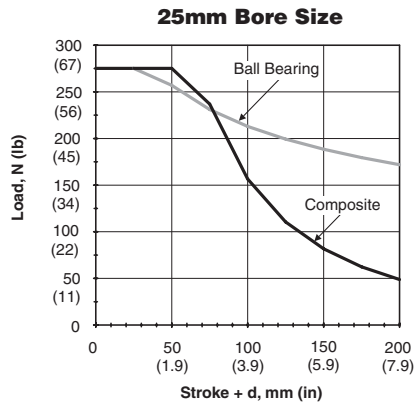
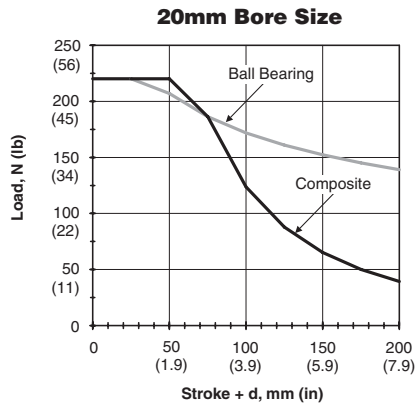
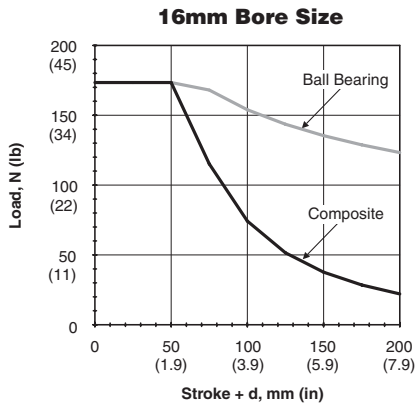
**Horizontal Load Capacity with High Load Bearings and Dual Tool Plate (D, A, B)**

P5T Series units will have the same load capacity regardless of orientation. The graphs below show maximum load capacity based on a unit life of 10 million cycles.

**EXAMPLE:** A P5T-20 with “stroke + d” of 100mm and high load composite bushings would have a load capacity of 125N.



	<b>Guided Cylinders</b>
	<b>P5T Series</b>
	<b>P5L Series</b>
<b>HB Series</b>	
<b>P5E Series</b>	
<b>XL Series</b>	



For inventory, lead times, and kit lookup, visit [www.pdnplu.com](http://www.pdnplu.com)

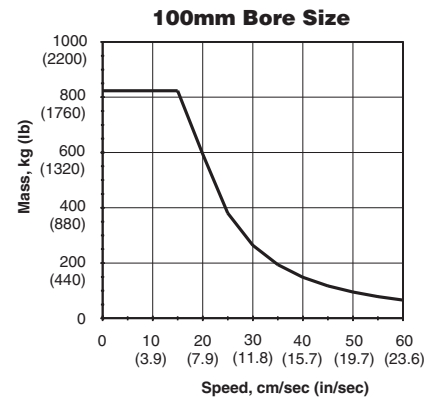
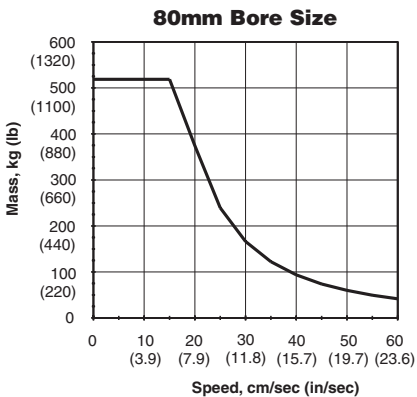
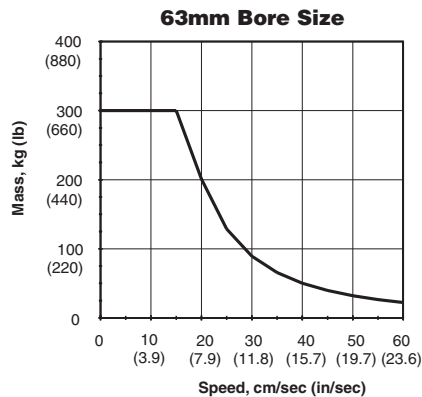
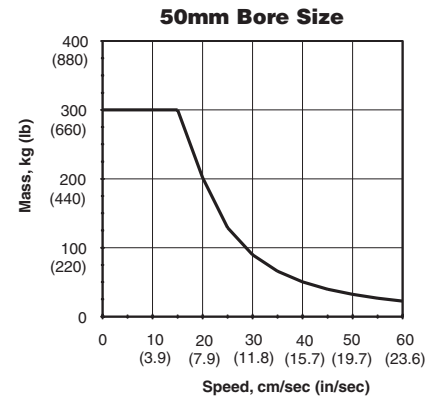
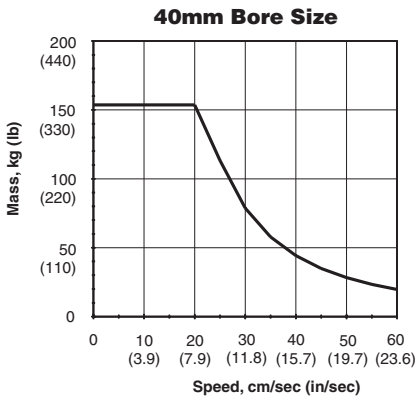
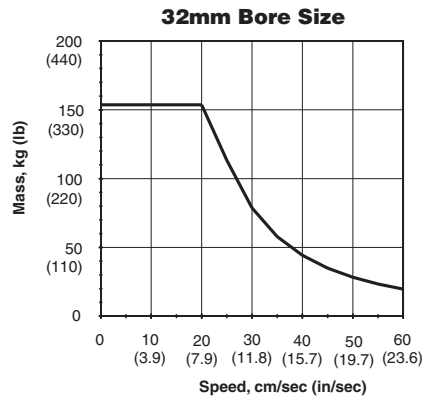
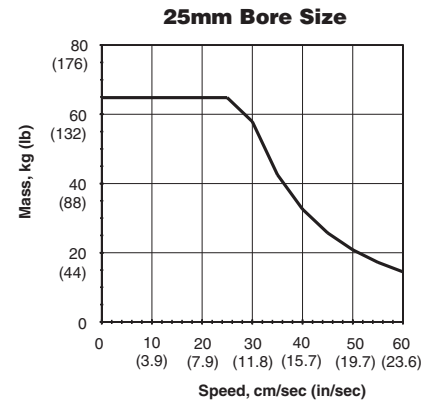
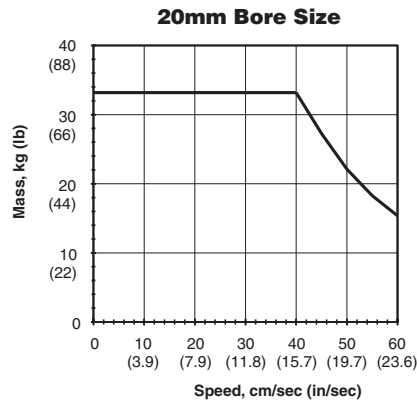
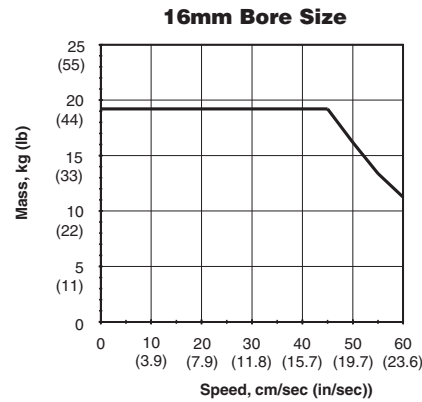
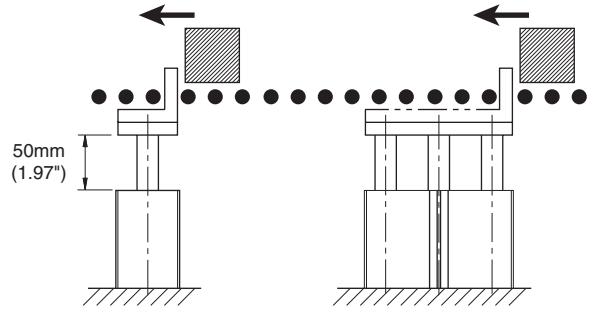
**Load Stopping Capacity Standard Unit**

P5T Series actuators are ideal for conveyor stopping applications. Units can be mounted horizontally or vertically.

**Composite bushings are strongly recommended for this type of application.**

**EXAMPLE:** A P5T-50 unit with a stroke up to 50mm will stop an object moving at 40 cm/second (15.75 in/s) that weighs up to 50 kg (110 lb).

**Note:** The following graphs are based on 50mm of stroke.



<b>P</b>
Guided Cylinders
P5T Series
P5L Series
HB Series
P5E Series
XL Series



For inventory, lead time, and kit lookup, visit [www.pdnplu.com](http://www.pdnplu.com)

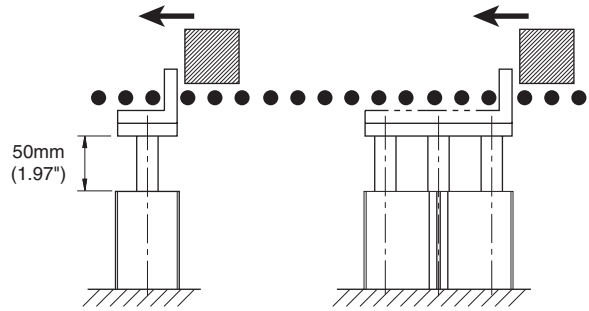
**Load Stopping Capacity with High Load Bearings and Dual Tool Plate (D, A, B)**

P5T Series actuators are ideal for conveyor stopping applications. Units can be mounted horizontally or vertically.

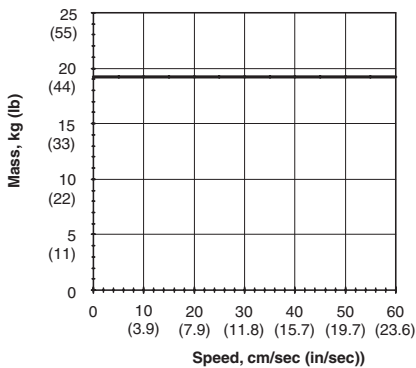
*Composite bushings are strongly recommended for this type of application.*

**EXAMPLE:** A P5T-25 unit with a stroke up to 50mm will stop an object moving at 40 cm/second (15.7 in/s) that weighs up to 46 kg (101 lb).

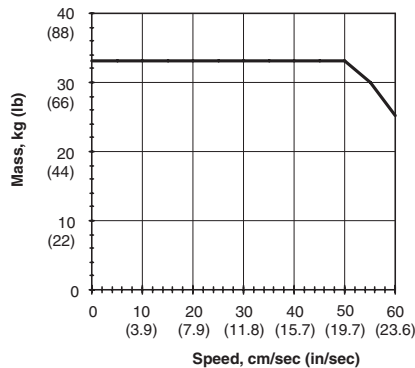
**Note:** The following graphs are based on 50mm of stroke.



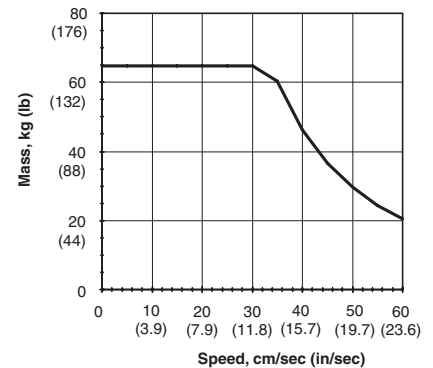
**16mm Bore Size**



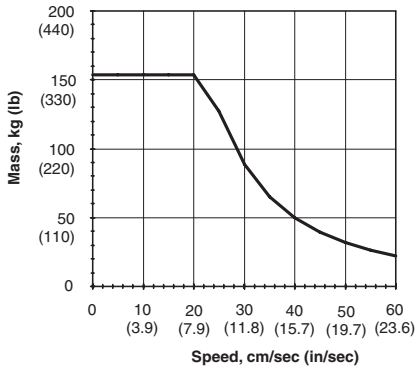
**20mm Bore Size**



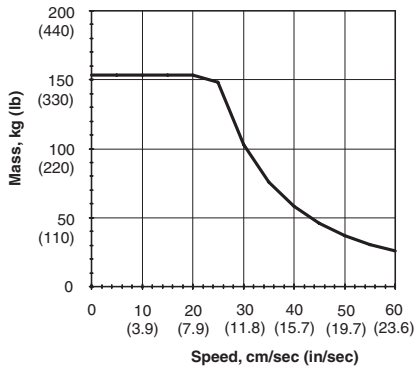
**25mm Bore Size**



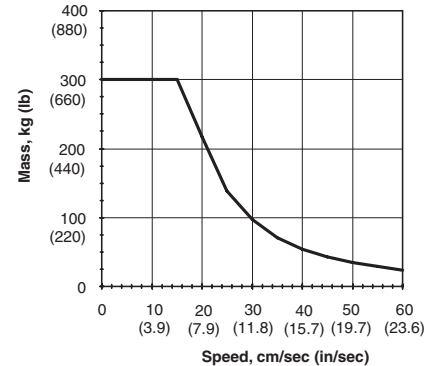
**32mm Bore Size**



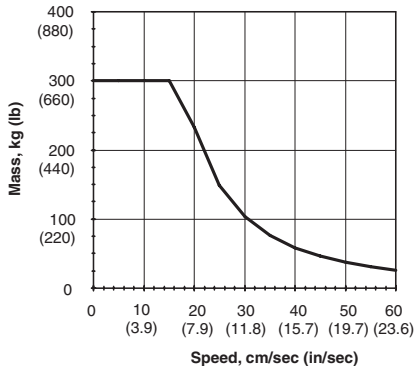
**40mm Bore Size**



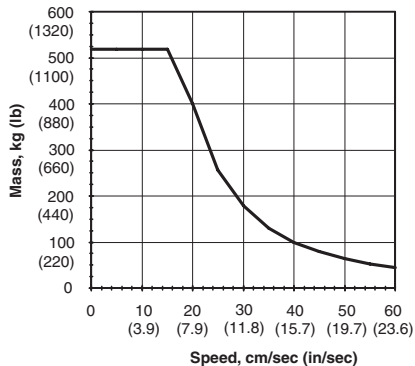
**50mm Bore Size**



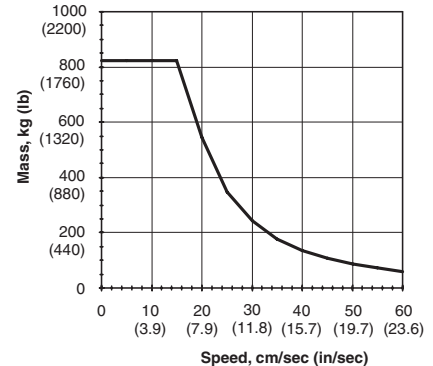
**63mm Bore Size**



**80mm Bore Size**



**100mm Bore Size**



**Guided Cylinders**  
**P5T Series**  
**P5L Series**  
**HB Series**  
**P5E Series**  
**XL Series**

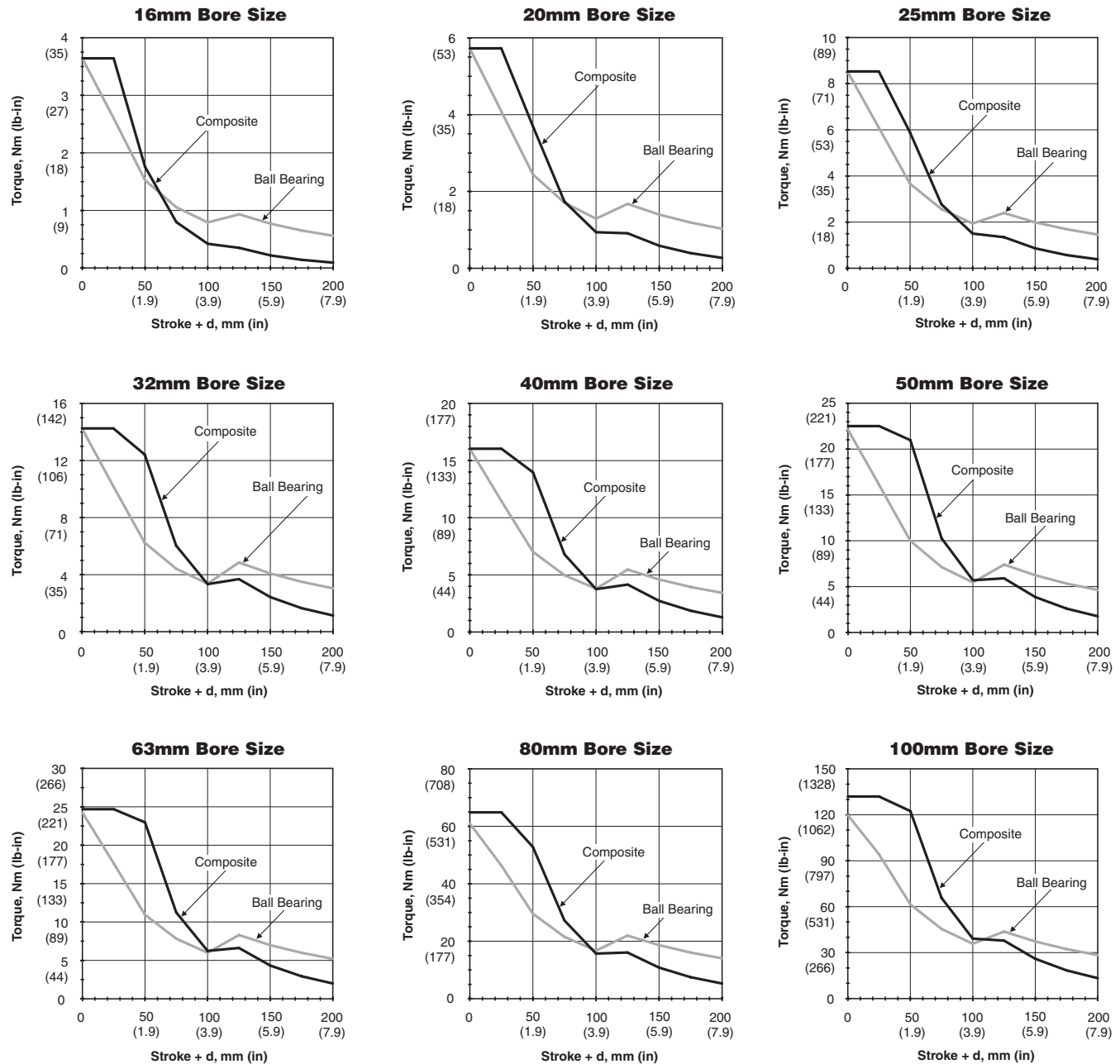
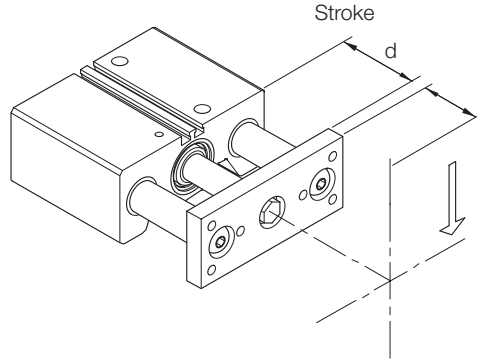


For inventory, lead times, and kit lookup, visit [www.pdnplu.com](http://www.pdnplu.com)

**Asymmetrical Torque Capacity Standard Unit**

Asymmetrical loading occurs when the load is applied to one side of the unit. P5T Series units can resist torsional loads that are asymmetrical.

**EXAMPLE:** A mechanism exerts an asymmetrical load of 15Nm on a P5T-50 with 50mm “stroke+d”. The P5T-50 with composite bushings will have adequate torsional capacity.



<b>M</b>
Guided Cylinders
P5T Series
P5L Series
HB Series
P5E Series
XL Series

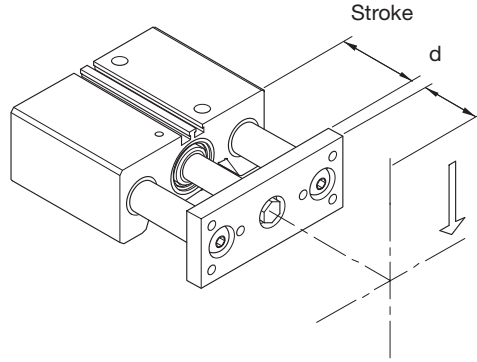


For inventory, lead time, and kit lookup, visit [www.pdnplu.com](http://www.pdnplu.com)

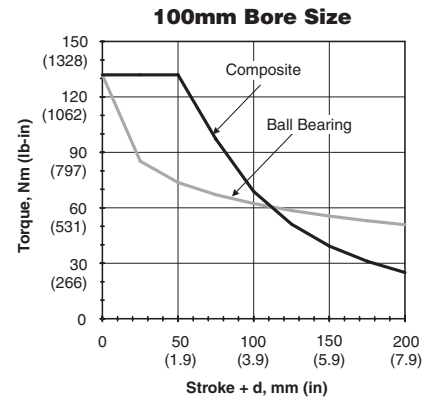
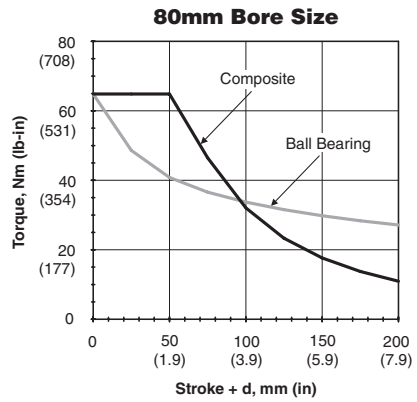
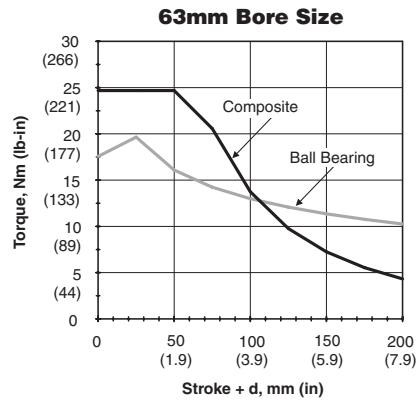
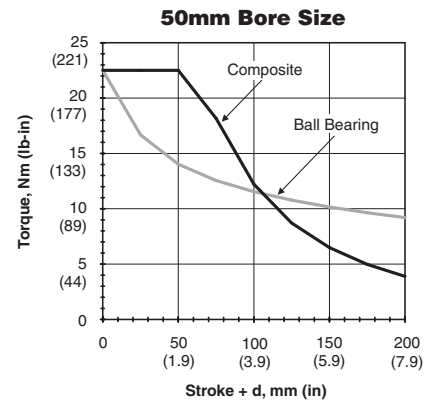
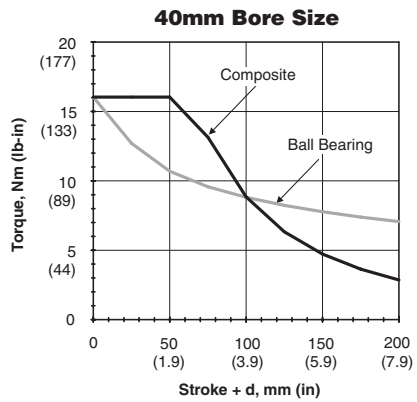
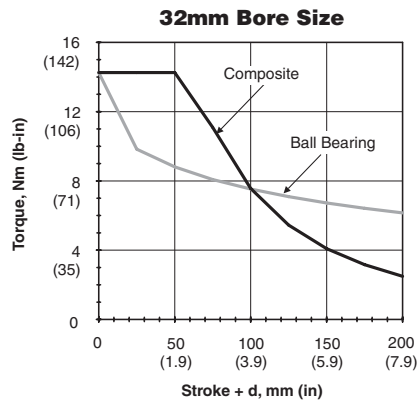
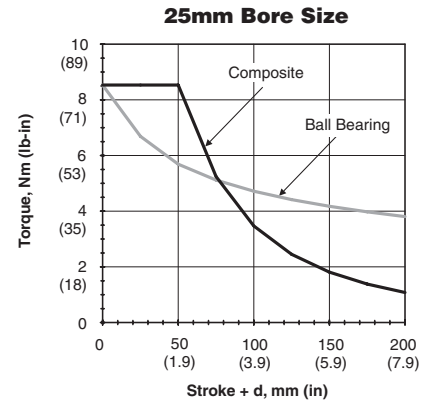
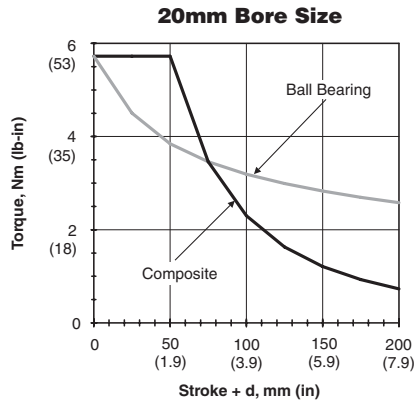
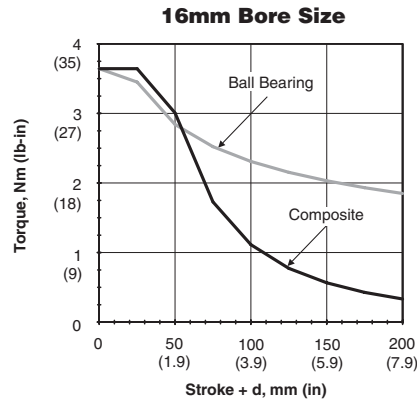
**Asymmetrical Torque Capacity with High Load Bearings and Dual Tool Plate (D, A, B)**

Asymmetrical loading occurs when the load is applied to one side of the unit. P5T Series units can resist torsional loads that are asymmetrical.

**EXAMPLE:** A mechanism exerts an asymmetrical load of 15Nm on a P5T-50 with 50mm “stroke+d”. The P5T-50 with composite bushings will have adequate torsional capacity.



	Guided Cylinders
	P5T Series
P5L Series	
HB Series	
P5E Series	
XL Series	



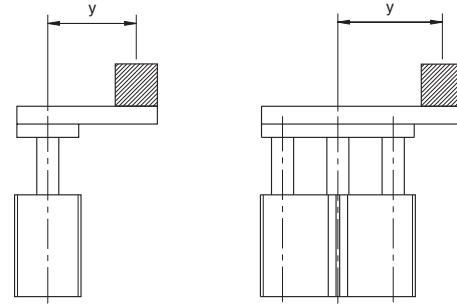
For inventory, lead times, and kit lookup, visit [www.pdnplu.com](http://www.pdnplu.com)



**Vertical Eccentric Load Capacity**  
**Standard Unit**

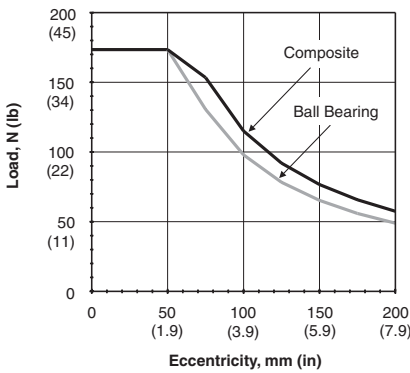
P5T Series units mounted vertically will have the same eccentric load capacity regardless of orientation. The graphs provide maximum load capacity for an eccentric mounted load. The load is assumed to be mounted at the face of the tooling plate.

These load curves illustrate load ratings based on the bearing system of the product. Load rating is a key selection criterion but is not the only one to consider in the selection of a product.

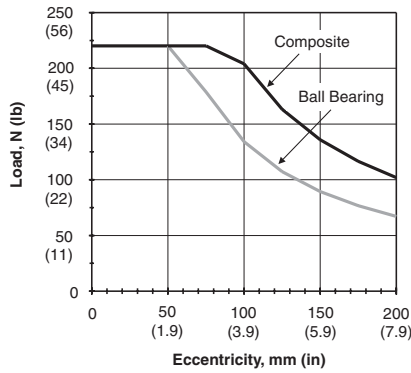


*y = eccentricity distance*

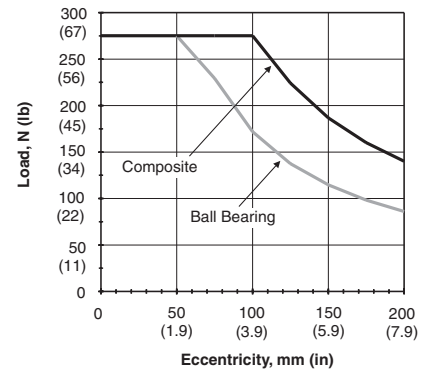
**16mm Bore Size**



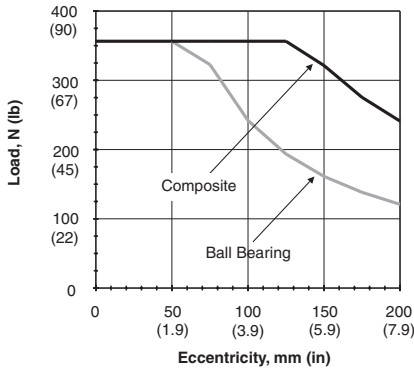
**20mm Bore Size**



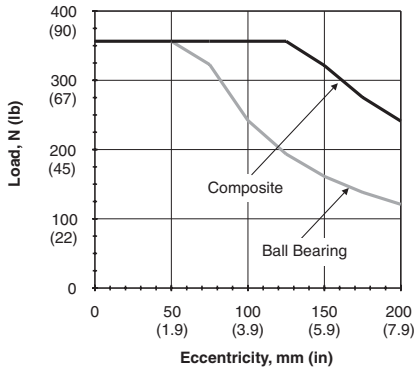
**25mm Bore Size**



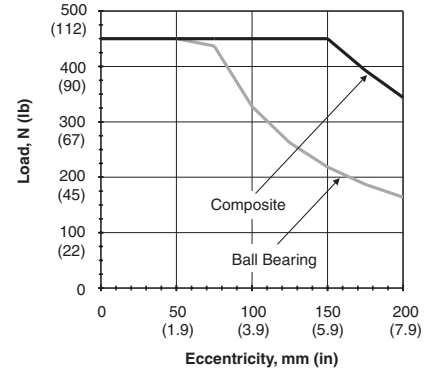
**32mm Bore Size**



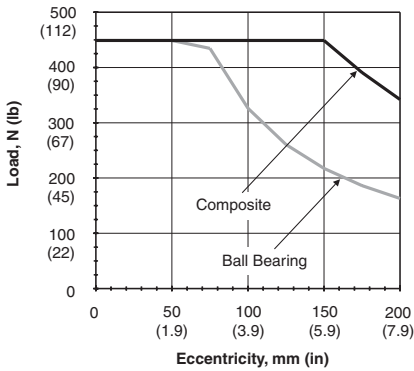
**40mm Bore Size**



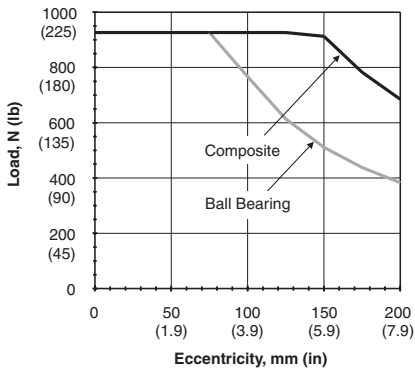
**50mm Bore Size**



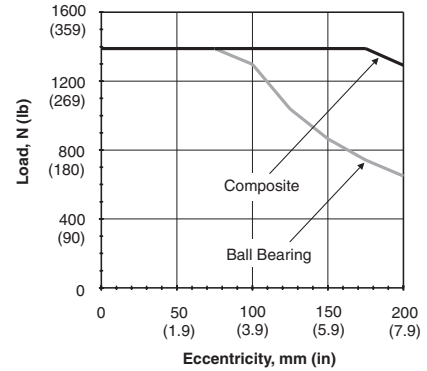
**63mm Bore Size**



**80mm Bore Size**



**100mm Bore Size**



<b>P</b>
Guided Cylinders
P5T Series
P5L Series
HB Series
P5E Series
XL Series

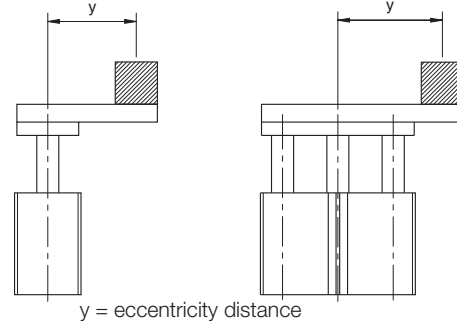


For inventory, lead time, and kit lookup, visit [www.pdnplu.com](http://www.pdnplu.com)

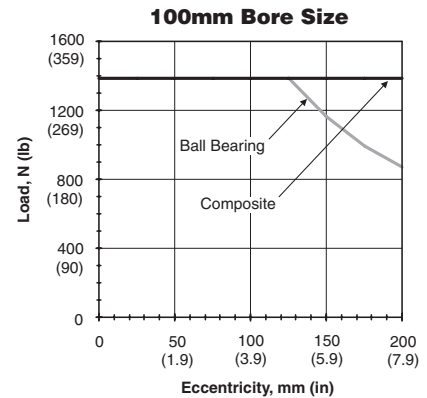
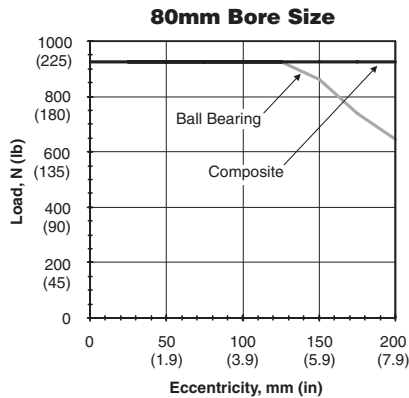
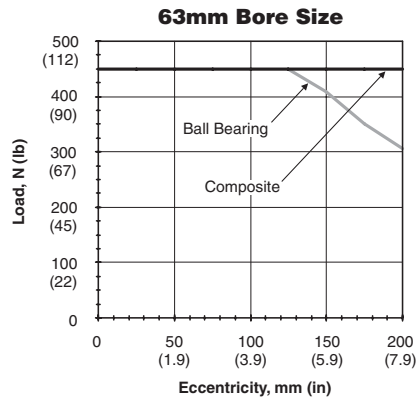
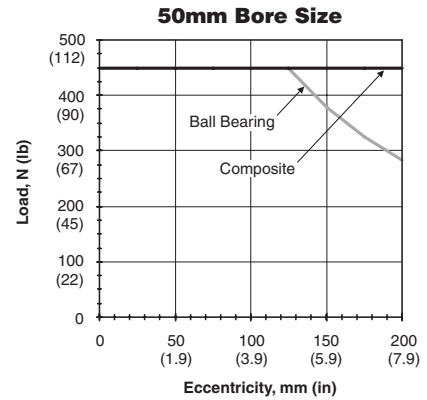
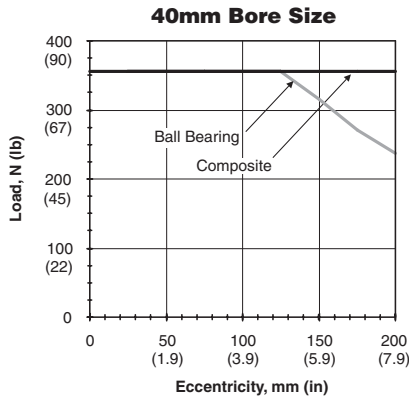
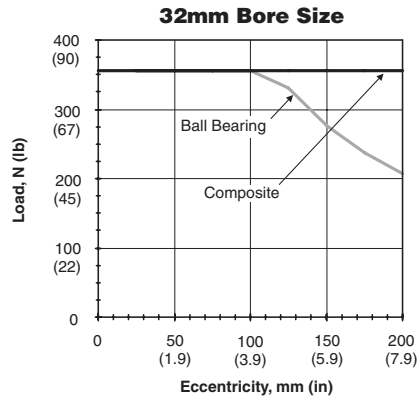
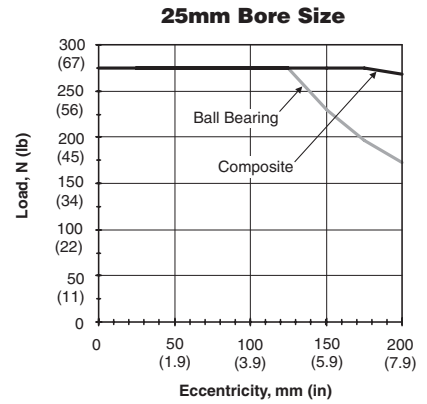
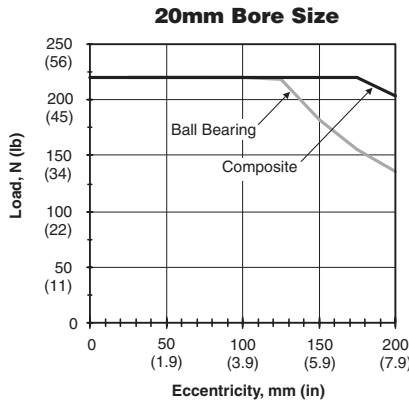
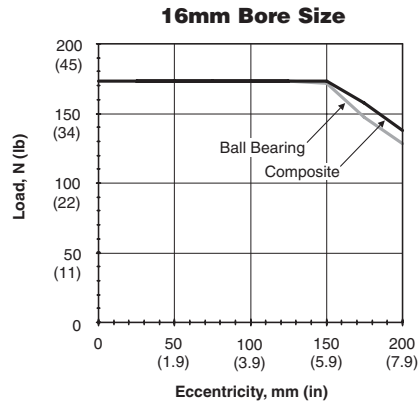
**Vertical Eccentric Load Capacity with High Load Bearings and Dual Tool Plate (D, A, B)**

P5T Series units mounted vertically will have the same eccentric load capacity regardless of orientation. The graphs provide maximum load capacity for an eccentric mounted load. The load is assumed to be mounted at the face of the tooling plate.

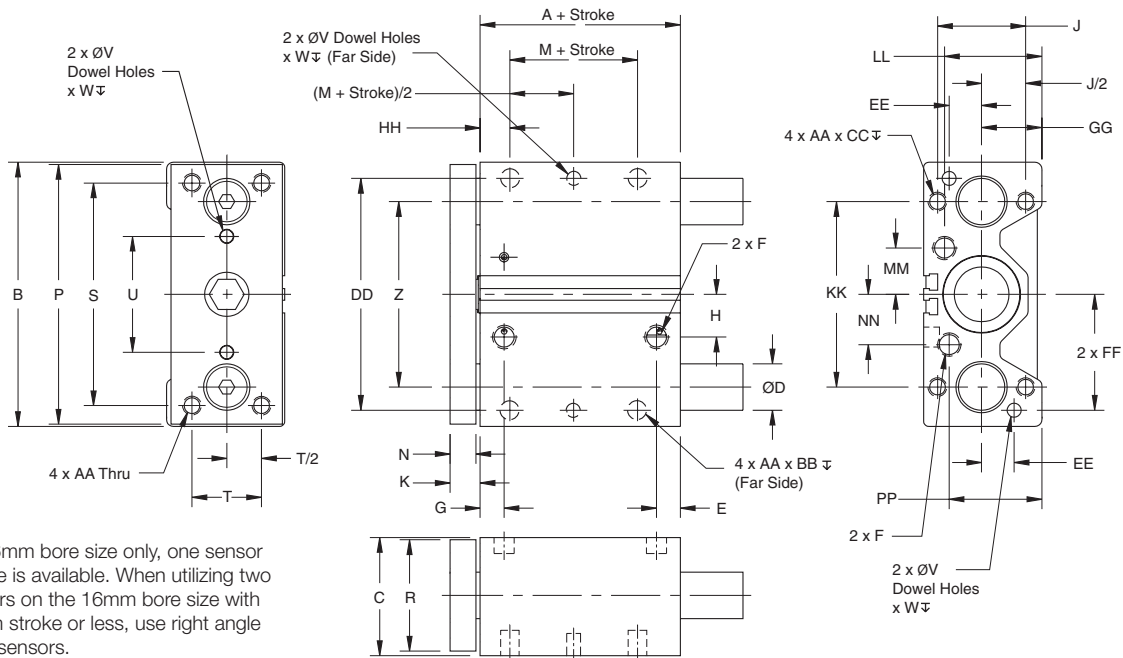
These load curves illustrate load ratings based on the bearing system of the product. Load rating is a key selection criterion but is not the only one to consider in the selection of a product.



**Guided Cylinders**  
**P5T Series**  
**P5L Series**  
**HB Series**  
**P5E Series**  
**XL Series**



For inventory, lead times, and kit lookup, visit [www.pdnplu.com](http://www.pdnplu.com)



**Note:** On 16mm bore size only, one sensor groove is available. When utilizing two sensors on the 16mm bore size with 25mm stroke or less, use right angle short sensors.

Dimensions in mm (inch)

**Note:** Dimensions for special stroke length actuators will be the same as those of the next longest stroke actuator.

Model	A**	B	C	D	D <sup>2</sup>	E**	F	G	H	J	K	
16	37.75 (1.49)	64 (2.52)	31 (1.22)	8 (0.315)	10 (0.394)	10.1 (0.40)	M5/10-32	10.1 (0.40)	6.95 (0.27)	22 (0.866)	9.94 (0.39)	
20	36 (1.42)	74 (2.91)	36 (1.42)	10 (0.394)	12 (0.472)	19 (0.75)	1/8 NPTF or BSPP	10 (0.39)	15.8 (0.62)	26 (1.024)	9.94 (0.39)	
25	38 (1.50)	88 (3.46)	42 (1.65)	12 (0.472)	16 (0.630)	21 (0.83)	1/8 NPTF or BSPP	11.4 (0.45)	15.5 (0.61)	32 (1.260)	9.94 (0.39)	
32	36 (1.42)	114 (4.49)	51 (2.00)	16 (0.630)	20 (0.787)	10.26 (0.40)	1/8 NPTF or BSPP	10.35 (0.41)	18.42 (0.73)	38 (1.496)	13.1 (0.52)	
40	44 (1.73)	124 (4.88)	52 (2.05)	16 (0.630)	20 (0.787)	12.10 (0.48)	1/8 NPTF or BSPP	14.9 (0.59)	22.53 (0.89)	38 (1.496)	13.1 (0.52)	
50	44.9 (1.77)	140 (5.51)	62 (2.44)	20 (0.787)	25 (0.984)	14.5 (0.57)	1/4 NPTF or BSPP	16.1 (0.63)	27 (1.06)	44 (1.732)	14.7 (0.58)	
63	50.05 (1.97)	150 (5.91)	75 (2.95)	20 (0.787)	25 (0.984)	16.4 (0.65)	1/4 NPTF or BSPP	14.5 (0.57)	33 (1.30)	44 (1.732)	14.7 (0.58)	
80	60.3 (2.37)	188 (7.40)	95 (3.74)	25 (0.984)	30 (1.181)	17.5 (0.610)	3/8 NPTF or BSPP	19 (0.75)	37 (1.46)	56 (2.205)	18 (0.71)	
100**	67.5 (2.60)	224 (8.82)	115 (4.53)	30 (1.181)	35 (1.38)	21.9 (0.862)	3/8 NPTF or BSPP	23 (0.91)	40 (1.57)	62 (2.441)	18 (0.71)	
Model	M	N	P	R	S	T	U	V	W	Z	AA	BB
16	7 (0.276)	7.94 (0.31)	62 (2.44)	25.4 (1.00)	52 (2.047)	16 (.630)	20 (0.787)	3 (0.118)	6 (0.236)	42 (1.654)	M5x0.8	7.5 (0.30)
20	10 (0.394)	7.94 (0.31)	72 (2.83)	31.8 (1.25)	60 (2.362)	18 (7.09)	30 (1.181)	4 (0.157)	6 (0.236)	52 (2.047)	M5x0.8	7.5 (0.30)
25	10 (0.394)	7.94 (0.31)	86 (3.39)	38 (1.50)	70 (2.756)	26 (1.024)	34 (1.339)	4 (0.157)	6 (0.236)	62 (2.441)	M6x1.0	9 (0.35)
32	5 (0.197)	11.1 (0.44)	112 (4.41)	44.5 (1.75)	96 (3.780)	30 (1.181)	50 (1.969)	6 (0.236)	6 (0.236)	80 (3.150)	M8x1.25	11 (0.43)
40	10 (0.394)	11.1 (0.44)	122 (4.80)	44.5 (1.75)	106 (4.173)	30 (1.181)	60 (2.362)	6 (0.236)	6 (0.236)	90 (3.543)	M8x1.25	11 (0.43)
50	10 (0.394)	12.7 (0.50)	138 (5.43)	57.2 (2.25)	120 (4.724)	40 (1.575)	60 (2.362)	8 (0.315)	8 (0.315)	100 (3.937)	M10x1.5	12 (0.47)
63	10 (0.394)	12.7 (0.50)	148 (5.83)	69.9 (2.75)	130 (5.118)	50 (1.969)	72 (2.835)	8 (0.315)	8 (0.315)	110 (4.331)	M10x1.5	15 (0.59)
80	15 (0.591)	16 (0.63)	185 (7.28)	89 (3.50)	160 (6.299)	60 (2.362)	92 (3.622)	10 (0.394)	10 (0.394)	140 (5.512)	M12x1.75	18 (0.71)
100	15 (0.591)	16 (0.63)	221 (8.70)	108 (4.25)	190 (7.480)	80 (3.150)	114 (4.488)	10 (0.394)	10 (0.394)	170 (6.693)	M14x2.0	21 (0.83)
Model	CC	DD	EE	FF	GG	HH	KK	LL	MM	NN	PP	Piston Rod
16	10 (0.39)	54 (2.126)	8 (0.315)	27 (1.063)	15 (0.591)	13.06 (0.514)	42 (1.654)	22.5 (0.88)	11.25 (0.44)	9.7 (0.38)	23.0 (0.91)	8 (0.315)
20	10 (0.39)	64 (2.520)	10 (0.394)	32 (1.260)	17 (0.669)	13.06 (0.514)	52 (2.126)	26.0 (1.02)	15.4 (0.61)	15.4 (0.61)	26.0 (1.0)	10 (0.394)
25	12 (0.47)	76 (2.992)	11 (0.433)	38 (1.496)	21 (0.827)	14.06 (0.553)	62 (2.441)	33.4 (1.31)	17 (0.67)	17 (0.67)	33.4 (1.31)	10 (0.394)
32	16 (0.63)	100 (3.937)	14 (0.551)	50 (1.969)	26 (1.024)	12.9 (0.508)	80 (3.150)	42 (1.65)	20 (0.79)	21.7 (0.85)	38 (1.50)	16 (0.630)
40	16 (0.63)	110 (4.33)	14 (0.551)	55 (2.165)	26 (1.024)	13.9 (0.547)	90 (3.543)	41 (1.61)	24 (0.95)	26.4 (1.04)	37.9 (1.49)	16 (0.630)
50	20 (0.79)	124 (4.882)	16 (0.630)	62 (2.441)	30 (1.181)	14.3 (0.563)	100 (3.937)	51 (2.01)	29 (1.14)	33 (1.30)	44 (1.73)	20 (0.787)
63	20 (0.79)	132 (5.197)	18 (0.709)	66 (2.598)	36.5 (1.437)	16.3 (0.642)	110 (4.331)	62 (2.44)	36 (1.42)	37.75 (1.49)	57.75 (2.27)	20 (0.787)
80	24 (0.94)	166 (6.535)	22 (0.866)	83 (3.268)	46.5 (1.831)	21 (0.83)	140 (5.512)	78 (3.07)	45 (1.77)	48 (1.89)	75.5 (2.97)	25 (0.984)
100	28 (1.10)	200 (7.874)	24 (0.945)	100 (3.937)	56.5 (2.224)	25 (0.98)	170 (6.693)	91.5 (3.60)	53 (2.09)	51 (2.01)	95.5 (3.76)	25 (0.984)

D<sup>1</sup> With linear ball bearing

D<sup>2</sup> With composite bushing

\*\* For Model 100 with 25mm stroke, A = 100.3 (3.95") and E = 28 (1.10")



For inventory, lead time, and kit lookup, visit [www.pdnplu.com](http://www.pdnplu.com)

E15

**Parker Hannifin Corporation**  
 Pneumatic Division  
 Richland, Michigan  
[www.parker.com/pneumatics](http://www.parker.com/pneumatics)

Options

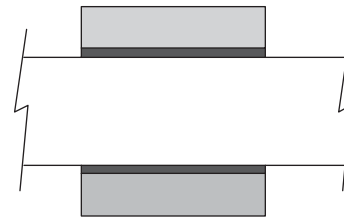
Shaft Bearings

Composite bushings are supplied as standard.  
Linear ball bearings are optional.

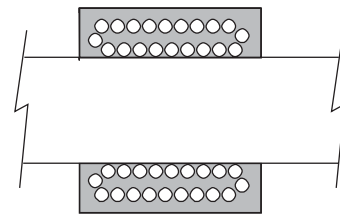
Selection should be based on the following criteria:

Application Requirement	Ball	Composite
Precision	Excellent	Good
Friction	Low	Higher
Friction coefficient	Constant	Variable
Precision over life of bearing	Constant	Variable
Static Load Capacity	Good	Excellent
Dynamic Load Capacity	Good	Good with lower efficiency
Vibration Resistance	Fair	Excellent
Contamination Resistance	Poor	Excellent
Washdown Compatibility	Poor	Excellent

For bearing load capacities, reference the Engineering Data section.



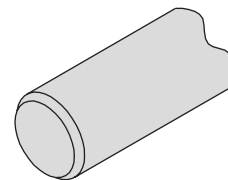
Composite Bushing (J,C)



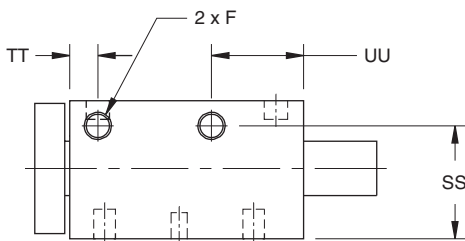
Recirculating Ball Bearing (H)

Corrosion Resistant Shafting (C, H)

Chrome-plated case hardened, high carbon alloy steel shafting with composite bearings is utilized for standard slides. This may corrode in some applications. Stainless steel corrosion resistant shafting is available.



Side Porting (S)




NOTES:

- Side ports not available on 100mm bore units with 25mm of stroke.
- Cannot use flow controls with 25mm stroke on any bore size.

Model	SS mm (in)	TT mm (in)	UU mm (in)	F
16	24.1 (.95)	10 (.39)	20 (.79)	10-32 or M5
20	29.00 (1.15)	10 (.39)	20 (.79)	10-32 or M5
25	35.15 (1.38)	11.4 (.45)	24 (.94)	10-32 or M5
32	43.2 (1.70)	10.35 (.41)	34 (1.34)	1/8 NPTF or BSPP
40	43.0 (1.69)	14.9 (.59)	34 (1.34)	1/8 NPTF or BSPP
50	51.25 (2.02)	16.1 (.64)	38 (1.50)	1/4 NPTF or BSPP
63	60.70 (2.39)	15.55 (.61)	41.8 (1.65)	1/4 NPTF or BSPP
80	75.5 (2.97)	19 (.75)	47 (1.85)	3/8 NPTF or BSPP
100	83.7 (3.30)	23 (.91)	53.3 (2.10)	3/8 NPTF or BSPP



For inventory, lead times, and kit lookup, visit [www.pdnplu.com](http://www.pdnplu.com)


 Guided Cylinders  
 P5T Series  
 P5L Series  
 HB Series  
 P5E Series  
 XL Series

**Options**

**Flow Controls (B, F, N, P)**

Right angle flow control valves allow precise adjustment of cylinder speed by metering exhaust air flow. Prestolok push-in or threaded ports provide 360° orientation capability.

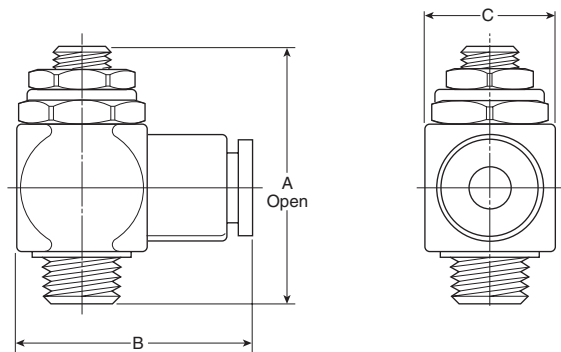
Model	A (in)	B (in)	C (in)	Imperial	
				Prestolok (F)	NPT (N)
16, 20*, 25*	0.87	0.96	0.39	5/32"	10-32
20, 25, 32, 40	1.63	1.38	0.67	5/32"	1/8
50, 63	1.86	1.64	0.91	1/4"	1/4
80, 100	2.15	1.90	1.06	3/8"	3/8

Model	A (mm)	B (mm)	C (mm)	Metric	
				Prestolok (P)	BSPP (B)
16, 20*, 25*	22.0	24.5	10.0	4mm	M5
20, 25, 32, 40	34.5	31.6	14.4	6mm	1/8
50	41.0	34.9	18.4	6mm	1/4
63	41.0	41.3	18.4	10mm	1/4
80	51.0	46.7	21.6	10mm	3/8
100	51.0	46.7	21.6	12mm	3/8

\* Side ports only.

**Note:** When flow controls are specified with rear ports, a 90° right angle fitting is supplied to provide ample rod clearance in the rear.

Prestolok flow controls are not available on 32-100mm bore sizes with 25mm of stroke.



**Fluorocarbon Seals (F)**

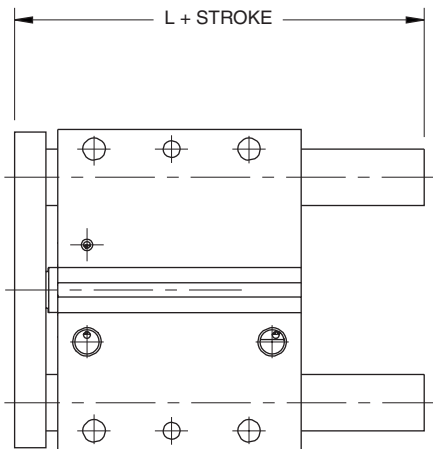
Standard abrasion resistant nitrile seals should be used for general purpose applications with temperatures of -18 to 74°C (0 to 165°F). Fluorocarbon seals are recommended for high temperature applications up to 121°C (250°F).

Feature	Temperature Range
Bumpers	-18 to 93°C (0 to 200°F)
Magnets	-18 to 74°C (0 to 165°F)
Sensors	-10 to 85°C (14 to 185°F)



For inventory, lead time, and kit lookup, visit [www.pdnplu.com](http://www.pdnplu.com)

Standard Length – No Options (N)



Model	Stroke (mm)	L	
		mm	inch
16	10*, 25, 40, 50, 75	60.2	2.37
	100	75.2	2.96
20	25, 40, 50, 75	66.9	2.63
	100, 125	91.9	3.62
25	25, 50, 75	69.9	2.75
	100, 125, 150	91.9	3.62
32	25, 50, 75, 100	77.9	3.07
	125, 150, 175, 200	116.0	4.57
40	25, 50, 75, 100	77.9	3.07
	125, 150, 175, 200	116.0	4.57
50	25, 50, 75, 100	84.0	3.31
	125, 150, 175, 200	124.1	4.89
63	25, 50, 75, 100	84.0	3.31
	125, 150, 175, 200	124.1	4.89
80	25, 50, 75, 100	101.8	4.00
	125, 150, 175, 200	140.0	5.51
100	25**, 50, 75, 100	120.3	4.74
	125, 150, 175, 200	158.4	6.24

\* For Model 16 with 10mm stroke, L = 37.7mm (1.48").

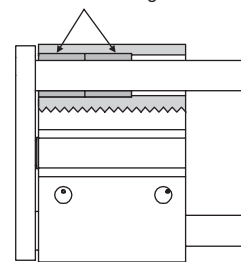
\*\* For Model 100 with 25mm stroke, L = 122.8mm (4.8").

High Load Bearings (B)

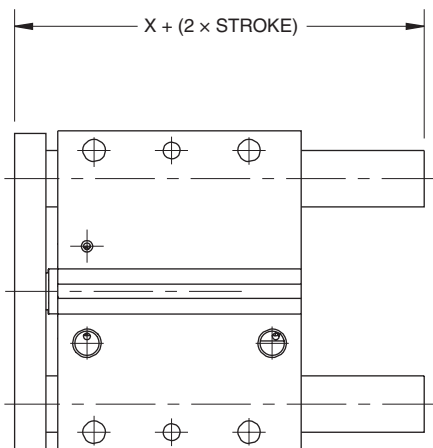
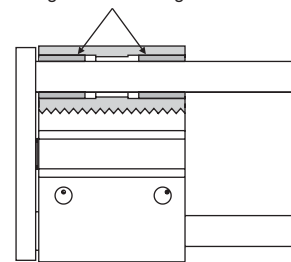
The standard bearing configuration locates both sets of bearings at the tooling plate end of the actuator providing a compact actuator package. The high load bearings option (B) locates the bearings at the extreme ends of the housing, increasing the dynamic and static load capacity. The bearing centerlines increase as stroke length increases.

**Note:** Rear mounting and ports are not available with the high load bearing option.

Standard Bearings



High Load Bearings



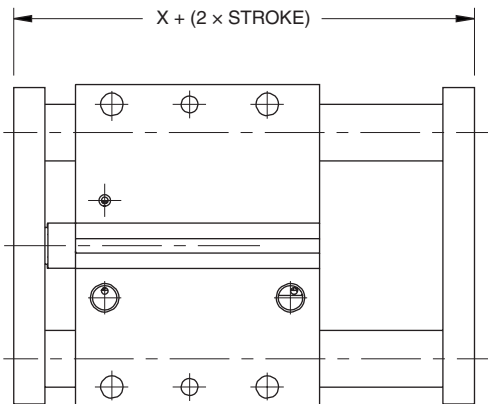
Model	X	
	mm	inch
16	49.7	1.955
20	47.0	1.849
25	49.9	1.963
32	51.1	2.012
40	59.1	2.327
50	61.6	2.425
63	66.8	2.630
80	79.6	3.135
100	86.1	3.391

P Guided Cylinders  
 P5T Series  
 P5L Series  
 HB Series  
 P5E Series  
 XL Series

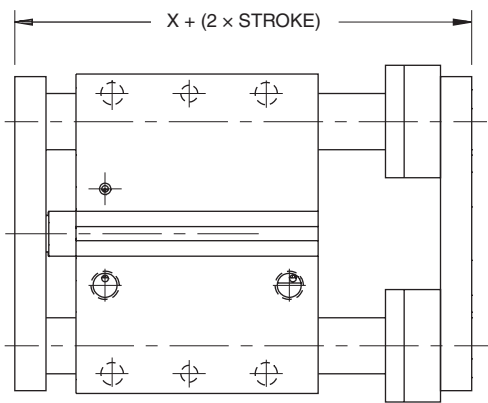


For inventory, lead times, and kit lookup, visit [www.pdnplu.com](http://www.pdnplu.com)

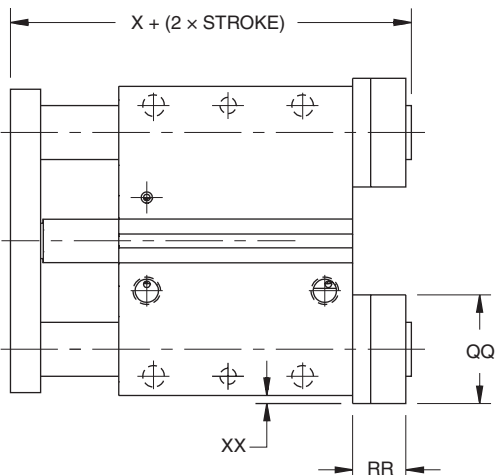
**Dual Tool Plate (D)**



**Bumpers, Stop Collars & Dual Tool Plate (A)**



**Bumpers & Adjustable Stop Collars, Extend Only (E)**



**Notes:**

1. Load capacities increase on dual tool plate (D & A). For load capacities, use the high load bearing graphs.
2. Rear mounting holes and rear ports are not available with Options D, A, and E.

Model	Rod dia.	X			QQ	RR	XX
		D option	A option	E option			
16	8	57.7 (2.27)	70.7 (2.78)	62.7 (2.47)	18.0 (0.71)	15.7 (0.62)	0
	10	57.7 (2.27)	70.7 (2.78)	62.7 (2.47)	24.0 (0.95)	15.7 (0.62)	1 (0.04)
20	10	54.7 (2.15)	67.9 (2.67)	59.9 (2.36)	24.0 (0.95)	15.7 (0.62)	1 (0.04)
	12	54.7 (2.15)	72.6 (2.86)	64.6 (2.54)	28.0 (1.10)	17.7 (0.70)	3 (0.12)
25	12	58.8 (2.31)	76.5 (3.01)	68.1 (2.68)	28.0 (1.10)	17.7 (0.70)	1 (0.04)
	16	58.8 (2.31)	78.5 (3.09)	70.1 (2.76)	34.0 (1.34)	19.7 (0.78)	4 (0.16)
32	16	62.2 (2.45)	81.9 (3.22)	70.8 (2.79)	34.0 (1.34)	19.7 (0.78)	0
	20	62.2 (2.45)	83.9 (3.30)	72.8 (2.87)	40.0 (1.57)	21.7 (0.85)	3.7 (0.15)
40	16	70.2 (2.76)	89.9 (3.54)	78.8 (3.10)	34.0 (1.34)	19.7 (0.78)	0
	20	70.2 (2.76)	91.9 (3.62)	80.8 (3.18)	41.4 (1.63)	21.7 (0.85)	3.7 (0.15)
50	20	74.3 (2.93)	96.0 (3.78)	83.3 (3.28)	41.4 (1.63)	21.7 (0.85)	0.7 (0.03)
	25	74.3 (2.93)	96.0 (3.78)	83.3 (3.28)	45.0 (1.77)	21.7 (0.85)	5.4 (0.21)
63	20	79.5 (3.13)	101.2 (3.98)	88.5 (3.48)	41.4 (1.63)	21.7 (0.85)	0.7 (0.03)
	25	79.5 (3.13)	101.2 (3.98)	88.5 (3.48)	50.8 (2.00)	21.7 (0.85)	5.4 (0.21)
80	25	96.1 (3.78)	117.8 (4.64)	101.9 (4.01)	50.8 (2.00)	21.7 (0.85)	1.4 (0.06)
	30	96.1 (3.78)	117.8 (4.64)	101.9 (4.01)	54.0 (2.13)	21.7 (0.85)	6.3 (0.25)
100	30	103.3 (4.07)	125.8 (4.95)	109.1 (4.30)	60.5 (2.38)	21.7 (0.85)	3.3 (0.13)
	35	103.3 (4.07)	125.8 (4.95)	109.1 (4.30)	57.0 (2.24)	21.7 (0.85)	5.5 (0.22)

All dimensions in mm (inch)

**M**  
Guided  
Cylinders

P5T  
Series

P5L  
Series

HB  
Series

P5E  
Series

XL  
Series

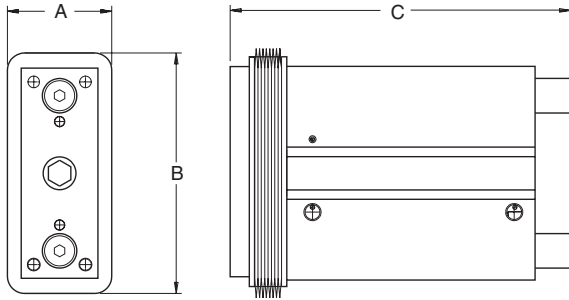
**Contaminant & Weld Flash Covers**

A contaminant cover protects the guide rods and bearings from particles and fluid that could cause premature failure.

A weld flash cover protects guide rods and bearings from weld spatter.

Cover option can be ordered on models having the bearings both ends option.

**Consult factory to order.**



**Weld Flash Cover Specifications**

Coating material (exposed side)	PVC (Black)
Base material	Nomex
Coating material (other side)	PVC (Black)
Material thickness range	.012" - .016" (.3-.4mm)
Temperature resistance (nomex)	
Briefly	642°F (450°C)
Continuously	-22° to 572°F (-30° to 300°C)
Temperature resistance (coating)	
Briefly	392°F (200°C)
Continuously	-22° to 302°F (-30° to 150°C)
Resistant to	Chemicals, coolants, solvents, oil
Characteristics	self-extinguishing, abrasion resistant
Material weight	400 grams/square meter

**Guided Cylinders**

**P5T Series**

**P5L Series**

**HB Series**

**P5E Series**

**XL Series**

**Standard stroke**

Model	A	B	Standard stroke									
			10	25	40	50	75	100	125	150	175	200
16	42 (1.65)	86 (3.39)	61.2 (2.41)	100.2 (3.94)	135.2 (5.32)	135.2 (5.32)	160.2 (6.31)	200.2 (7.88)	-	-	-	-
20	45 (1.77)	98 (3.86)	-	106.9 (4.21)	141.9 (5.59)	141.9 (5.59)	166.9 (6.57)	216.9 (8.54)	241.9 (9.52)	-	-	-
25	49 (1.93)	112 (4.41)	-	119.9 (4.72)	-	144.9 (5.70)	169.9 (6.69)	194.9 (7.67)	241.9 (9.52)	266.9 (10.51)	-	-
32	62 (2.44)	142 (5.59)	-	127.9 (5.04)	-	152.9 (6.02)	177.9 (7.00)	202.9 (7.99)	266 (10.47)	291 (11.46)	316 (12.44)	341 (13.43)
40	62 (2.44)	152 (5.98)	-	127.9 (5.04)	-	152.9 (6.02)	177.9 (7.00)	202.9 (7.99)	266 (10.47)	291 (11.46)	316 (12.44)	341 (13.43)
50	66 (2.60)	167 (6.57)	-	134 (5.28)	-	159 (6.26)	184 (7.24)	209 (8.23)	274.1 (10.79)	299.1 (11.78)	324.1 (12.76)	349.1 (13.74)
63	77 (3.03)	187 (7.36)	-	134 (5.28)	-	159 (6.26)	184 (7.24)	209 (8.23)	274.1 (10.79)	299.1 (11.78)	324.1 (12.76)	349.1 (13.74)
80	104 (4.09)	244 (9.61)	-	151.8 (5.98)	-	176.8 (6.96)	201.8 (7.94)	226.8 (8.93)	290 (11.42)	315 (12.40)	340 (13.39)	365 (14.37)
100	109 (4.29)	279 (10.98)	-	170.3 (6.70)	-	195.3 (7.69)	220.3 (8.67)	245.3 (9.66)	308.4 (12.14)	333.4 (13.13)	358.4 (14.11)	383.4 (15.09)

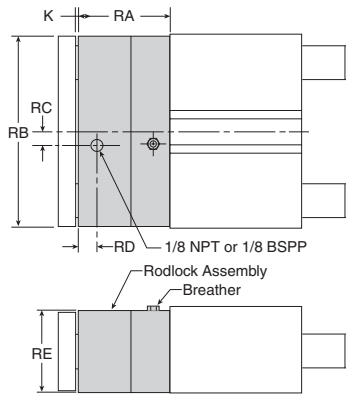
All dimensions in mm (inch)



For inventory, lead times, and kit lookup, visit [www.pdnplu.com](http://www.pdnplu.com)



**P5T Rodlock**



Bore	RA	RB	RC	RD	RE	K
32	58 (2.28)	112 (4.41)	6 (0.24)	10 (0.39)	49.50 (1.95)	2 (0.08)
40	58 (2.28)	122 (4.80)	6 (0.24)	10 (0.39)	49.50 (1.95)	2 (0.08)
50	66 (2.60)	138 (5.43)	10 (0.39)	13 (0.51)	59.30 (2.33)	2 (0.08)
63	83 (3.27)	148 (5.83)	7 (0.28)	18 (0.71)	69.90 (2.75)	2 (0.08)
80	100 (3.94)	185 (7.28)	10 (0.39)	26 (1.02)	90.70 (3.57)	2 (0.08)
100	116 (4.57)	221 (8.70)	10 (0.39)	43 (1.69)	108.00 (4.25)	2 (0.08)

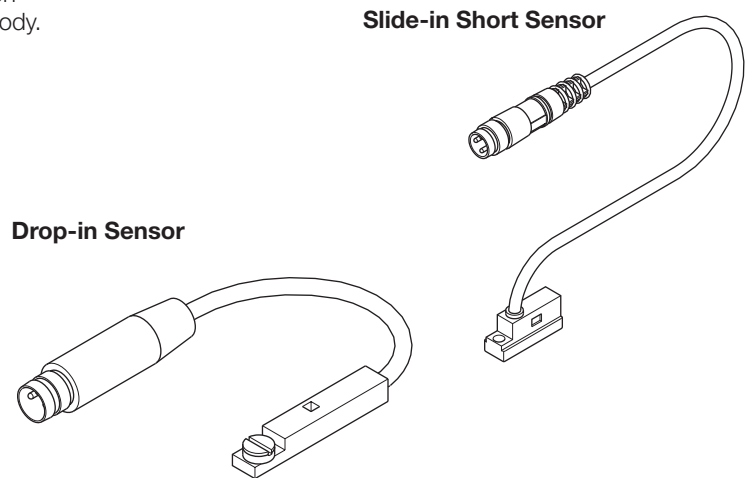
Dimensions in mm (inch)

**Reed and Solid State Sensors**

Sensors are available in both short and standard configurations. Both styles mount in the sensor grooves on the P5T body. The standard sensors mount flush to the body. The short sensor extends out 4.5mm to the cable. Both styles are available with quick connector or flying leads.

Magnetic piston is standard.

See Electronic Sensors section for part numbers and specifications.



**Seal Kits**

Bore size	Seal kit part number	
	Nitrile seals	Fluorocarbon seals
16	PSK-P5T16	PSK-P5T16-F
20	PSK-P5T20	PSK-P5T20-F
25	PSK-P5T25	PSK-P5T25-F
32	PSK-P5T32	PSK-P5T32-F
40	PSK-P5T40	PSK-P5T40-F
50	PSK-P5T50	PSK-P5T50-F
63	PSK-P5T63	PSK-P5T63-F
80	PSK-P5T80	PSK-P5T80-F
100	PSK-P5T100	PSK-P5T100-F



Guided Cylinders

P5T Series

P5L Series

HB Series

P5E Series

XL Series



For inventory, lead time, and kit lookup, visit [www.pdnplu.com](http://www.pdnplu.com)

Features

P5L Series

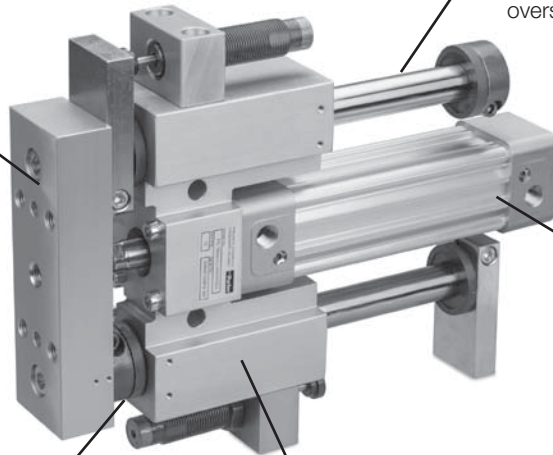
P5L-R Reach Slide Shown

**TOOLING PLATE**

A precision machined, anodized aluminum tooling plate with standard tapped and counterbored mounting holes provides mounting from two faces. Dowel pin holes are also included for accurate positioning of custom tooling. The support rods are attached to the tooling plate using two socket head cap screws, providing maximum rigidity and support.

**SUPPORT RODS**

High strength, case hardened support rods available in chrome plated, carbon or stainless steel. The chrome plated and stainless steel shafts are available in oversized versions for high load applications.



**CYLINDER**

P1D and SR cylinders are both available to power the P5L guided cylinder product line. Parker guided cylinders come standard with a magnetic piston for easy installation of reed or solid state sensors.

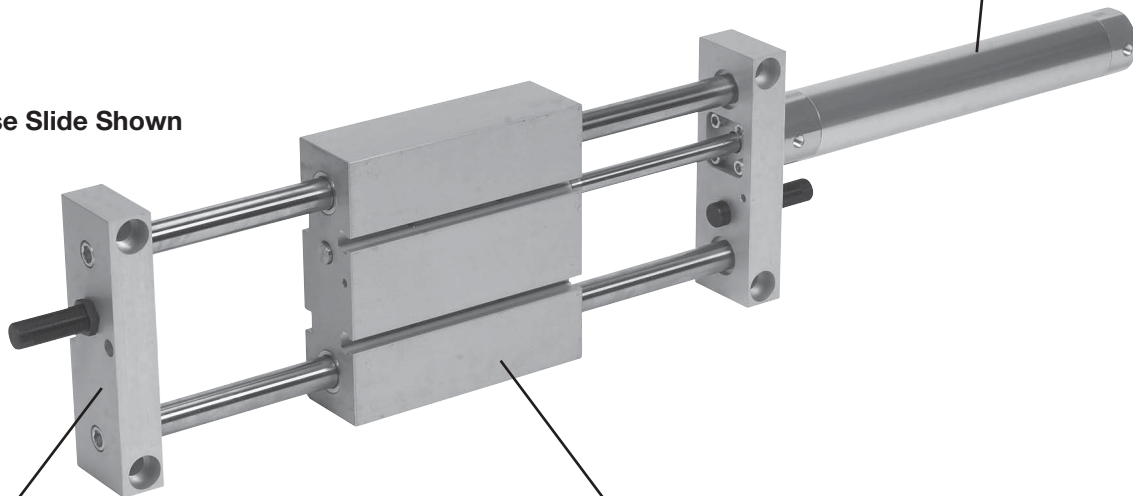
**BUSHINGS**

Composite bushings with standard or oversized shafts are available. For precision applications optional recirculating ball bearings can be specified and for extremely high loads self-aligning ball bearings are available.

**BODY**

Extruded aluminum and anodized body with recessed through holes. Standard dowel pin holes to provide mounting accuracy. Integrated T-slots provide mounting flexibility and quick set up. T-slots are standard on 20mm to 40mm bore models and optional on 50mm to 100mm bore models.

P5L-B Base Slide Shown



**END PLATES**

Precision machined, anodized aluminum end plates have counterbored through holes for mounting. For precision, one keyway and one dowel pin are included. The support rods are attached to the tooling plate using two socket head cap screws providing maximum rigidity and support.

**CARRIAGE**

Extruded aluminum and anodized carriage with recessed through holes. Standard dowel pin holes to provide mounting accuracy. Integrated t-slots provide mounting flexibility and quick set up. T-slots are standard on 20-40mm bore models and optional on 50-100mm bore models.

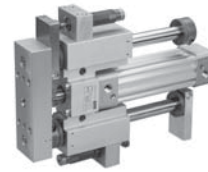
	Guided Cylinders
P5T Series	
P5L Series	
HB Series	
P5E Series	
XL Series	



For inventory, lead times, and kit lookup, visit [www.pdnplu.com](http://www.pdnplu.com)

## Features

- 3 body styles (Thrust, Reach, Base)
- 8 bore sizes 20mm to 100mm
- Maximum strokes 400 to 1000mm depending on model
- 3 Bearing options: composite, ball bearing, self-aligning ball bearing
- Dowel holes standard on body and tool plate
- Available with adjustable stroke and shock absorbers
- Powered by either P1D or SR cylinders
- Rod lock options available



## Operating information

Operating pressure:	10 bar (145 PSIG)
Temperature range:	Standard seals -17°C to 74°C (0°F to 165°F) Fluorocarbon seals* -17°C to 121°C (0°F to 250°F) *
	See fluorocarbon seal option for high temperature applications.
Operating characteristics:	Double acting
Filtration requirements:	40 micron, dry filtered air

## Ordering information

**P5L - R B 032 J1 A A N N N - 0450 - A**

**Series**

T	Thrust slide
R	Reach slide
B	Base slide

**Cylinder seals**

N	Seals are determined by cylinder type selection
---	---

**Design series**

A	Current design
---	----------------

**Stroke length**

Order in 1mm increments.	
--------------------------	--

**Cylinder type \***

SRM 020 - 080 Bore	S	SRM Cylinder (Standard Seals)
	T	SRM Cylinder (High Temp Seals)
P1D 032 - 100 Bore	B	P1D-B Cylinder (Standard Seals)
	H	P1D-G Cylinder (High Temp Seals)
	R	P1D-R Cylinder (Rod Lock, Standard Seals)
	U	P1D-R Cylinder (Rod Lock, High Temp Seals)

\* All cylinders include cushions, both ends.

**Bore size**

Code	P1D (ISO)	SRM (inch)
020	N/A	0.75 in
025	N/A	1.06 in
032	32mm	1.25 in
040	40mm	1.50 in
050	50mm	2.00 in
063	63mm	2.50 in
080	80mm	3.00 in
100	100mm	N/A

**Bushings**

J1	Composite bushing, chrome plated shafts
J2	Composite bushing, oversized chrome plated shafts
J3	Composite bushing, stainless steel shafts
J4	Composite bushing, oversized stainless steel shafts
G1	Composite bushing, chrome plated shafts, contaminant tolerant seals
G3	Composite bushing, stainless steel shafts, contaminant tolerant seals
H3	Linear ball bearings, stainless steel shafts
S3*	Self aligning linear ball bearings, stainless steel shafts

† Contaminant tolerant seals are not rated for high temperatures.  
‡ Self aligning ball bearings are not available on 020 bore size and not rated for high temperatures.

**Proximity sensor options**

N	No Sensor
P	PNP, lead type
R	NPN, lead type
S	PNP, plug in type
T	NPN, plug in type
W	Prox ready, 8mm (no sensor supplied)
Z	Prox ready, 12mm (no sensor supplied)

\*\* Not available on sizes 20-40

**NOTES:** Piston magnet is standard on all cylinders. All P1D cylinders include sensor slots, see electronic sensor selection guide for options. Inductive proximity sensors are included with Options P, R, S & T.

**Cylinder port style**

	P1D	SR	
G	BSPT ports	Yes	No
H	NPTF ports	Yes	Yes
P	BSPT ports w/ Prestolok flow controls (mm)	Yes	No
F	NPTF ports w/ Prestolok flow controls (inch)	Yes	Yes
B	BSPT ports w/ flow controls	Yes	No
N	NPTF ports w/ flow controls	Yes	Yes

**Extend options \***

N	None
A	Shock/stroke adjusters
B	Bumpers (base slides only)
E	Micro-adjusters and cushions (both ends only)
K	Bumpers and adjustable stop collars
L	Shock absorbers and bumpers (N/A on base slides)

\* All cylinders include cushions, both ends.

**Retract options \***

N	None
A	Shock/stroke adjusters
B	Bumpers only
E	Micro-adjusters and cushions (both ends only)
K	Bumpers and adjustable stop collars
L	Shock absorbers and bumpers (N/A on base slides)

\* All cylinders include cushions, both ends.

**Sensors**

See section L for sensors.



**Specifications**

- Maximum operating pressure: 10 bar (145 PSI)
  - Operating characteristics: double acting
  - Support rod sizes from 10mm to 60mm
  - Operating temperature range (cylinder):
    - Standard seals -17° to 74°C (0 to 165°F)
    - Fluorocarbon seals\* -17° to 121°C (0 to 250°F)
  - Filtration requirement: 40 micron filtered, dry air
- \*See fluorocarbon seal option for high temperature applications.

**Quick Reference Data**

Bore	Standard support rod diameter		Oversized support rod diameter		Output force on extension @5.5 bar (80 psi)		Output force on retract @5.5 bar (80 psi)		Maximum suggested stroke**	
	mm	(in)	mm	in	N	lbs	N	lbs	mm	in
20	10	0.39	12	0.47	173	39	147	33	400	16
25	12	0.47	16	0.63	271	61	227	51	400	16
32	16	0.63	20	0.79	445	100	383	86	450	18
40	20	0.79	25	0.98	694	156	583	131	550	22
50	25	0.98	30	1.18	1081	243	907	204	750	30
63	30	1.18	40	1.57	1717	386	1548	348	900	35
80	40	1.57	50	1.97	2771	623	2500	562	1000	39
100	50	1.97	60	2.36	4332	974	3888	874	1000	39

\*\*Longer stroke lengths are available, but load capacities are greatly reduced. Consult factory with application parameters.

**Weights**

Part number	Guide system (Kg)		SRM cylinder (Kg)		P1D cylinder (Kg)	
	Zero stroke	Stroke adder per mm	Zero stroke	Stroke Adder per mm	Zero Stroke	Stroke adder per mm

**Base Slide**

P5L-B?020J2NNNHN-0000-A	1.02	0.0018	0.09	0.0006	N/A	N/A
P5L-B?025J2NNNHN-0000-A	2.16	0.0032	0.16	0.0009	N/A	N/A
P5L-B?032J2NNNHN-0000-A	3.36	0.0049	0.27	0.0013	0.55	0.0023
P5L-B?040J2NNNHN-0000-A	5.83	0.0077	0.33	0.0015	0.80	0.0033
P5L-B?050J2NNNHN-0000-A	12.37	0.0111	0.75	0.0027	1.20	0.0048
P5L-B?063J2NNNHN-0000-A	22.52	0.0198	1.07	0.0030	1.73	0.0051
P5L-B?080J2NNNHN-0000-A	41.37	0.0309	1.88	0.0047	2.45	0.0075
P5L-B?100J2NNNHN-0000-A	71.84	0.0445	N/A	N/A	4.00	0.0084

**Reach Slide**

P5L-R?020J2NNNHN-0000-A	0.80	0.0018	0.09	0.0006	N/A	N/A
P5L-R?025J2NNNHN-0000-A	1.60	0.0032	0.16	0.0009	N/A	N/A
P5L-R?032J2NNNHN-0000-A	2.70	0.0049	0.27	0.0013	0.55	0.0023
P5L-R?040J2NNNHN-0000-A	4.24	0.0077	0.33	0.0015	0.80	0.0033
P5L-R?050J2NNNHN-0000-A	9.34	0.0111	0.75	0.0027	1.20	0.0048
P5L-R?063J2NNNHN-0000-A	17.43	0.0198	1.07	0.0030	1.73	0.0051
P5L-R?080J2NNNHN-0000-A	32.06	0.0309	1.88	0.0047	2.45	0.0075
P5L-R?100J2NNNHN-0000-A	56.71	0.0445	N/A	N/A	4.00	0.0084

**Thrust Slide**

P5L-T?020J2NNNHN-0000-A	0.574	0.0018	0.09	0.0006	N/A	N/A
P5L-T?025J2NNNHN-0000-A	1.194	0.0032	0.16	0.0009	N/A	N/A
P5L-T?032J2NNNHN-0000-A	1.985	0.0049	0.27	0.0013	0.55	0.0023
P5L-T?040J2NNNHN-0000-A	3.252	0.0077	0.33	0.0015	0.80	0.0033
P5L-T?050J2NNNHN-0000-A	6.871	0.0111	0.75	0.0027	1.20	0.0048
P5L-T?063J2NNNHN-0000-A	12.808	0.0198	1.07	0.0030	1.73	0.0051
P5L-T?080J2NNNHN-0000-A	23.438	0.0309	1.88	0.0047	2.45	0.0075
P5L-T?100J2NNNHN-0000-A	41.529	0.0445	N/A	N/A	4.00	0.0084



For inventory, lead times, and kit lookup, visit [www.pdnplu.com](http://www.pdnplu.com)

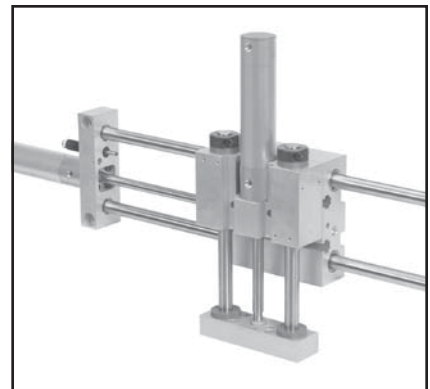
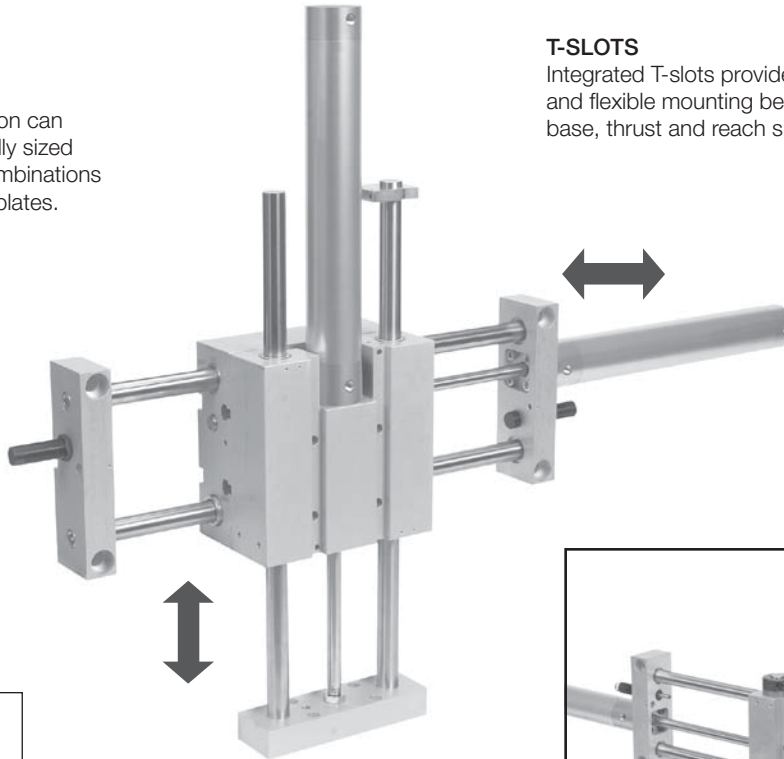
**Guided Cylinders**  
 P5T Series  
 P5L Series  
 HB Series  
 P5E Series  
 XL Series

**DIRECT MOUNTING**

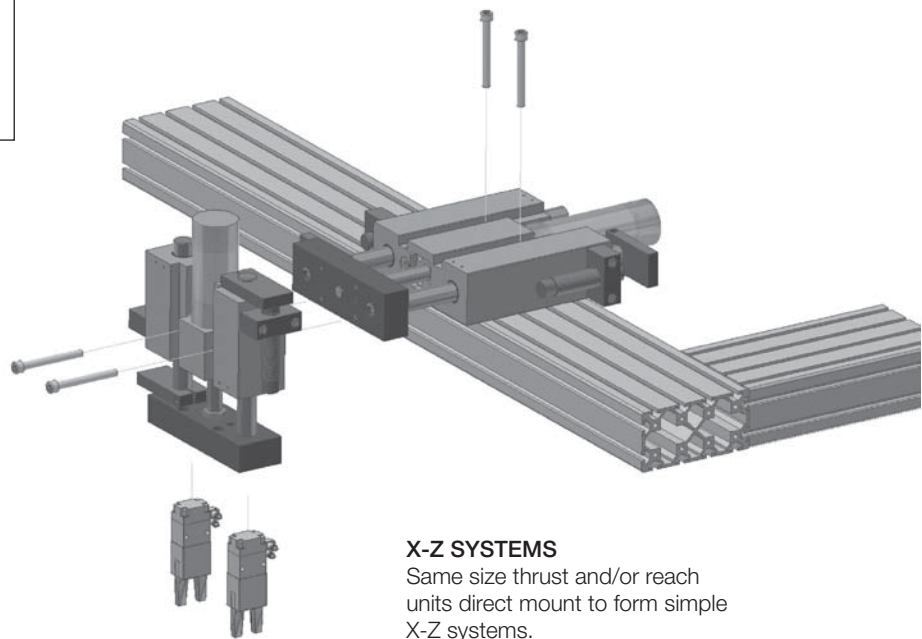
Each thrust and reach version can direct mount to the identically sized base version. Other size combinations can mount using transition plates.

**T-SLOTS**

Integrated T-slots provide quick and flexible mounting between base, thrust and reach slides.



Parker has a complete line of pneumatic grippers for pick & place applications.



**X-Z SYSTEMS**

Same size thrust and/or reach units direct mount to form simple X-Z systems.

<b>M</b>	<b>Guided Cylinders</b>
	<b>P5T Series</b>
	<b>P5L Series</b>
	<b>HB Series</b>
	<b>P5E Series</b>
	<b>XL Series</b>



For inventory, lead time, and kit lookup, visit [www.pdnplu.com](http://www.pdnplu.com)

**Horizontal Load Capacity & Deflection with Standard Shafting**

- Standard Composite w/ Chrome Plated or Stainless Steel Rods
- Recirculating Ball Bearings w/ Stainless Steel Rods
- Self Aligning Ball Bearings w/ Stainless Steel Rods

The graphs on the following two pages illustrate the maximum suggested side load at a given actuator stroke and distance (d) from the face of the tooling plate. The graphs include the weight of the support rods and tooling plate and are based on a bearing life of 10 million cycles under a dynamic loading condition. For an equivalent static load capacity multiply the information in these graphs by 1.5.

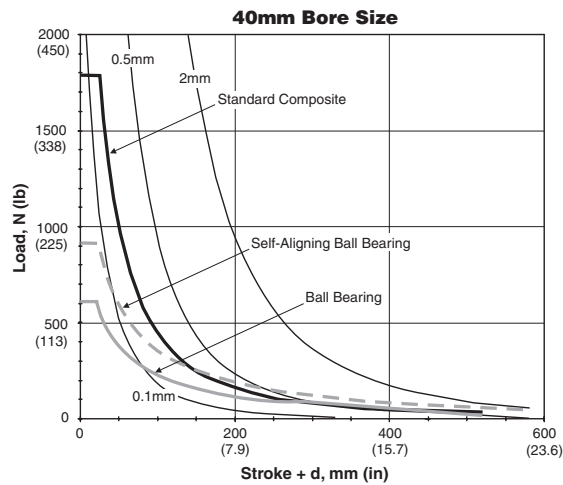
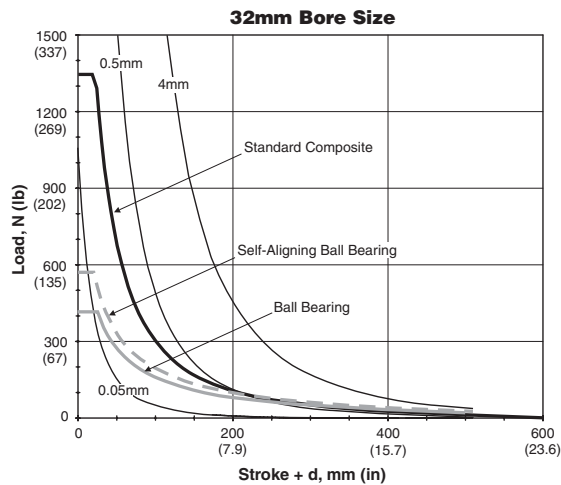
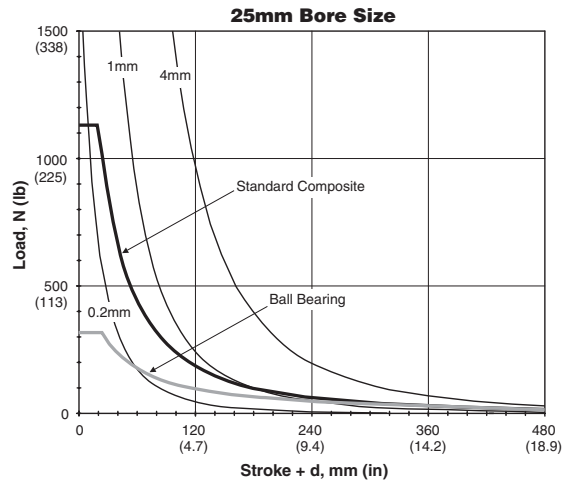
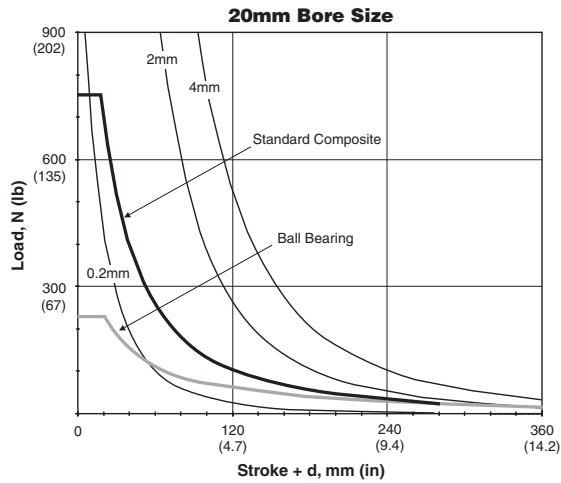
See the P5L options section of this catalog for more bearing selection information.

Dynamic loading is defined as a load which is affixed to the actuator tooling plate during the extend or retract motion of the actuator. Capacities are based on bearing and shafts only. Mounting bolts/hardware should be investigated per customer application.

**Note:** The following variables commonly affect the bearing life of a guided cylinder:

- Velocity
- Vibration
- Orientation
- Environment (Dust, moisture, etc.)

**P5L Thrust Slides**

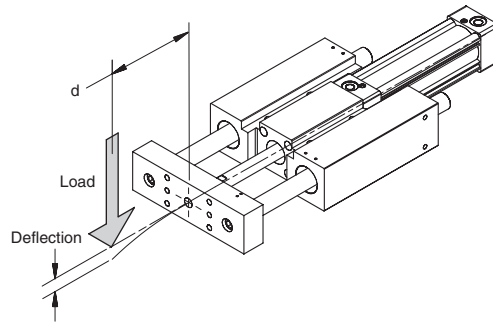


Guided Cylinders	P5T Series	P5L Series	HB Series	P5E Series	XL Series

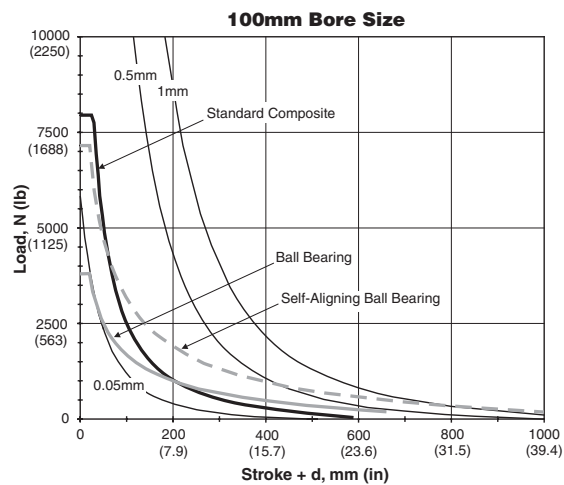
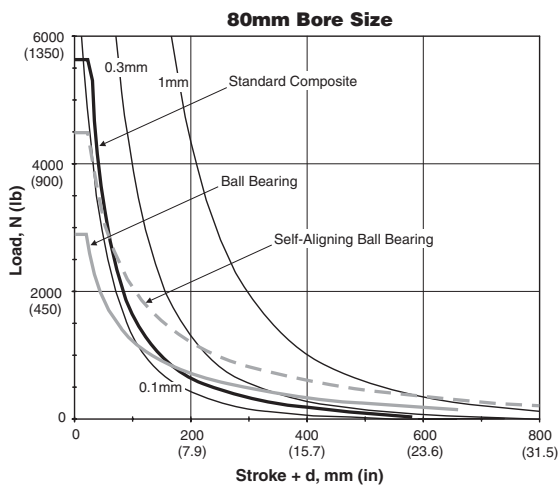
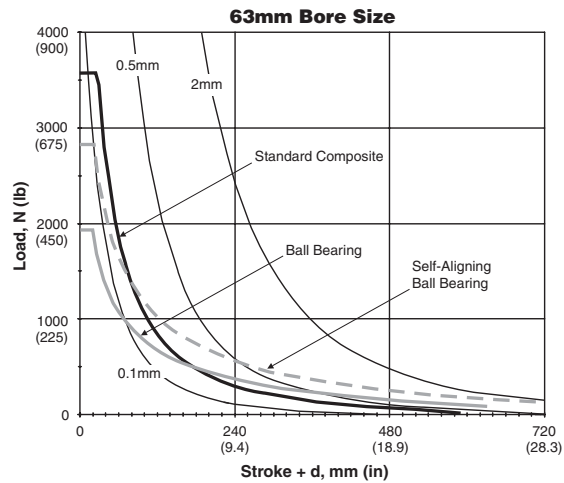
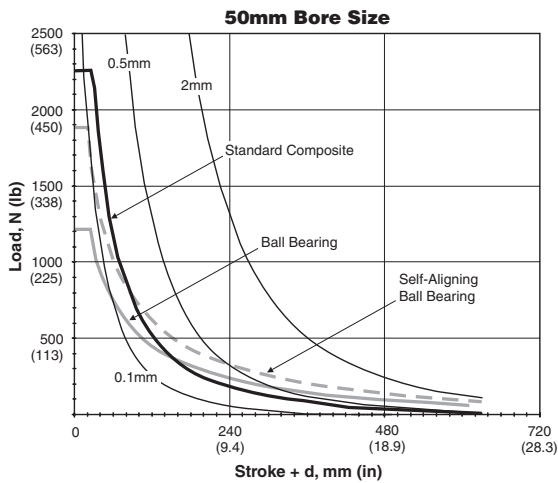


For inventory, lead times, and kit lookup, visit [www.pdnplu.com](http://www.pdnplu.com)

**Horizontal Load Capacity & Deflection with Standard Shafting**



**P5L Thrust Slides**



<b>P</b>	Guided Cylinders
P5T Series	P5L Series
HB Series	P5E Series
XL Series	



For inventory, lead time, and kit lookup, visit [www.pdnplu.com](http://www.pdnplu.com)

**Horizontal Load Capacity & Deflection with Oversized Shafting**

- Oversized Composite w/ Chrome Plated or Stainless Steel Rods

The graphs on the following two pages illustrate the maximum suggested side load at a given actuator stroke and distance (d) from the face of the tooling plate. The graphs include the weight of the support rods and tooling plate and are based on a bearing life of 10 million cycles under a dynamic loading condition. For an equivalent static load capacity multiply the information in these graphs by 1.5.

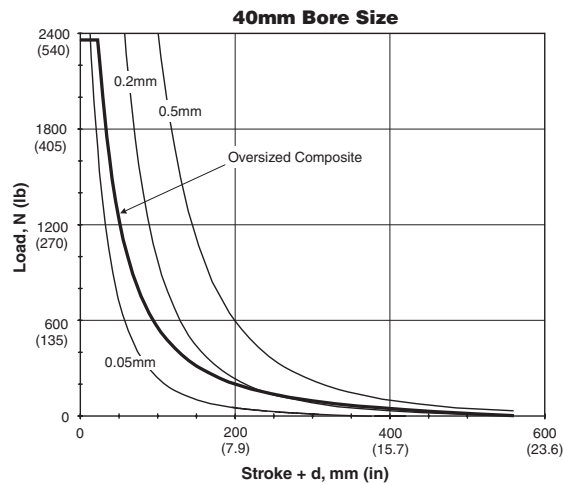
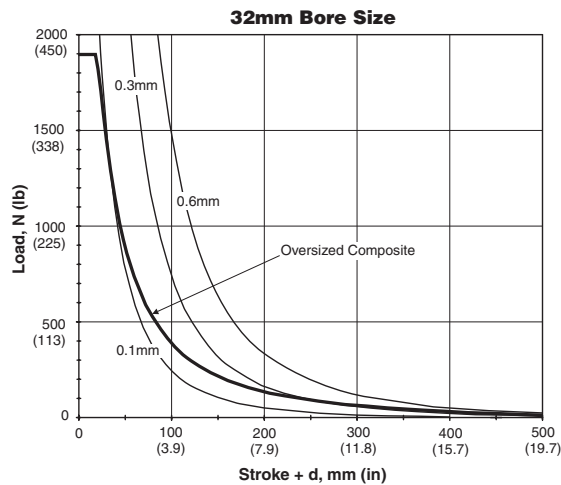
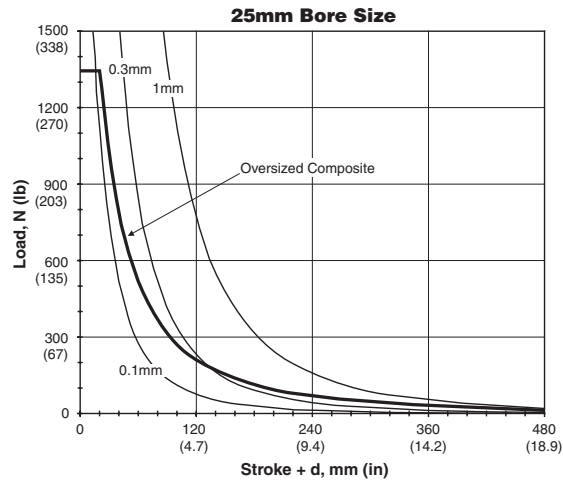
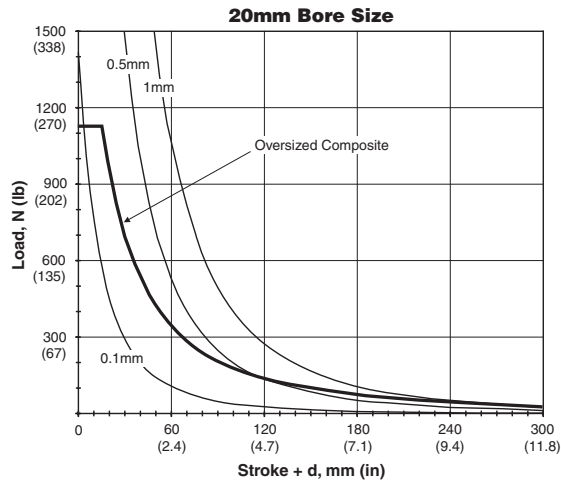
See the P5L options section of this catalog for more bearing selection information.

Dynamic loading is defined as a load which is affixed to the actuator tooling plate during the extend or retract motion of the actuator. Capacities are based on bearing and shafts only. Mounting bolts/hardware should be investigated per customer application.

**Note:** The following variables commonly affect the bearing life of a guided cylinder:

- Velocity
- Vibration
- Orientation
- Environment (Dust, moisture, etc.)

**P5L Thrust Slides**



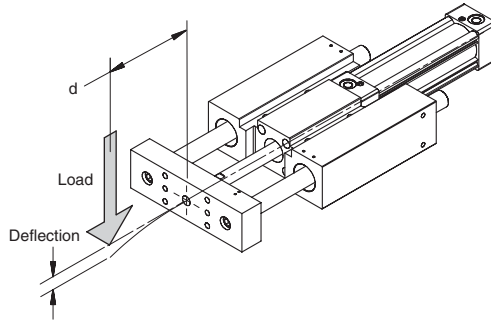
Guided Cylinders	P5T Series
	P5L Series
Series	HB Series
	P5E Series
	XL Series



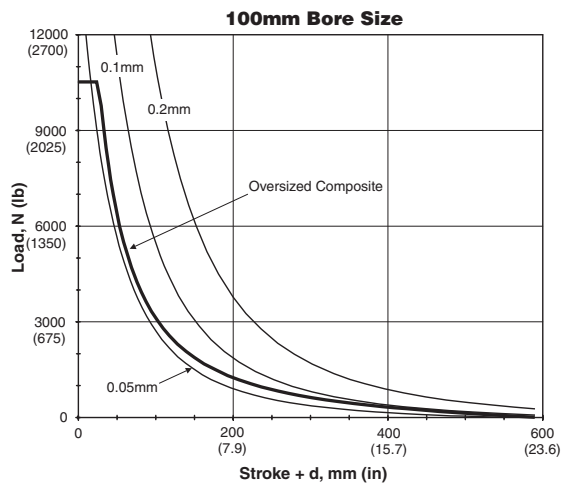
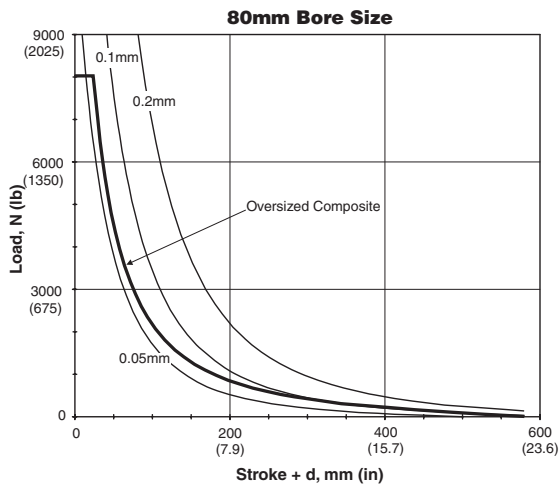
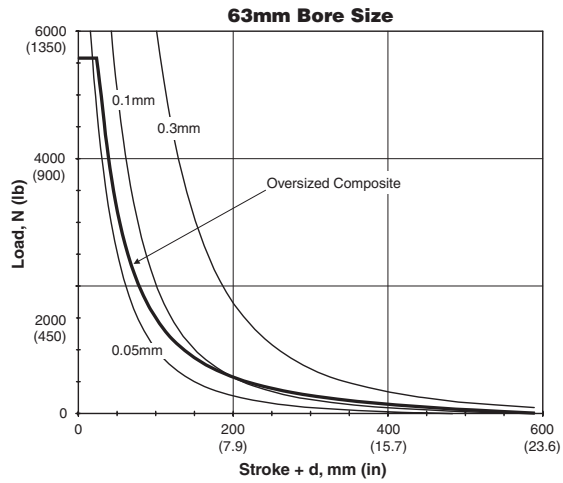
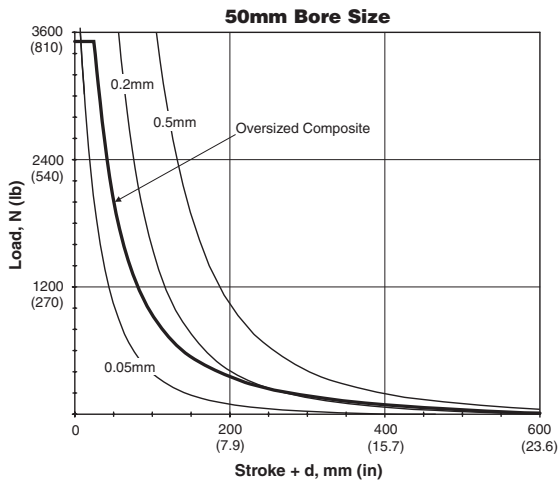
For inventory, lead times, and kit lookup, visit [www.pdnplu.com](http://www.pdnplu.com)



**Horizontal Load Capacity & Deflection with Oversized Shafting**



**P5L Thrust Slides**



E	Guided Cylinders
	P5T Series
P5L Series	
HB Series	
P5E Series	
XL Series	



For inventory, lead time, and kit lookup, visit [www.pdnplu.com](http://www.pdnplu.com)

**Horizontal Load Capacity & Deflection with Standard Shafting**

- Standard Composite w/ Chrome Plated or Stainless Steel Rods
- Recirculating Ball Bearings w/ Stainless Steel Rods
- Self Aligning Ball Bearings w/ Stainless Steel Rods

The graphs on the following two pages illustrate the maximum suggested side load at a given actuator stroke and distance (d) from the face of the tooling plate. The graphs include the weight of the support rods and tooling plate and are based on a bearing life of 10 million cycles under a dynamic loading condition. For an equivalent static load capacity multiply the information in these graphs by 1.5.

See the P5L options section of this catalog for more bearing selection information.

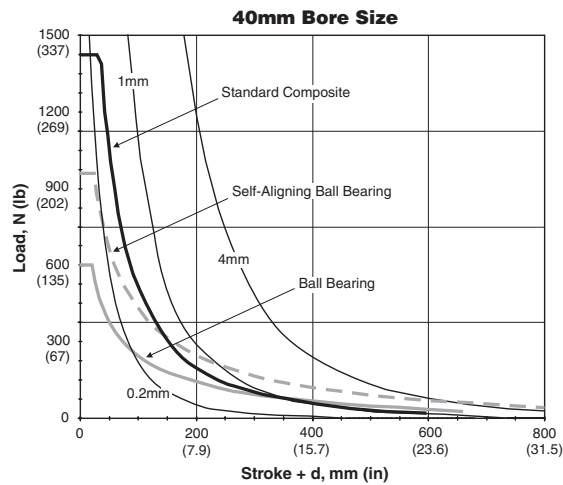
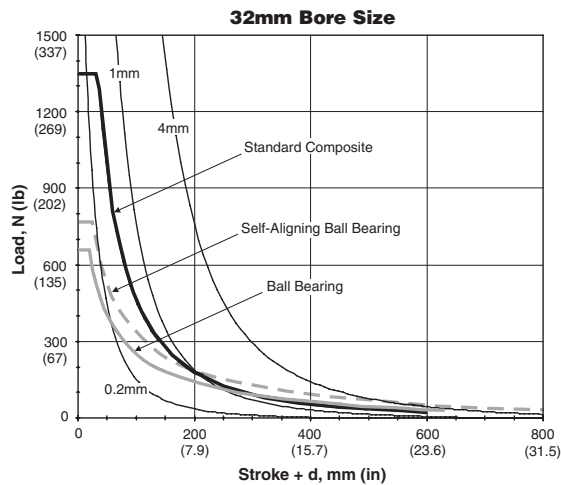
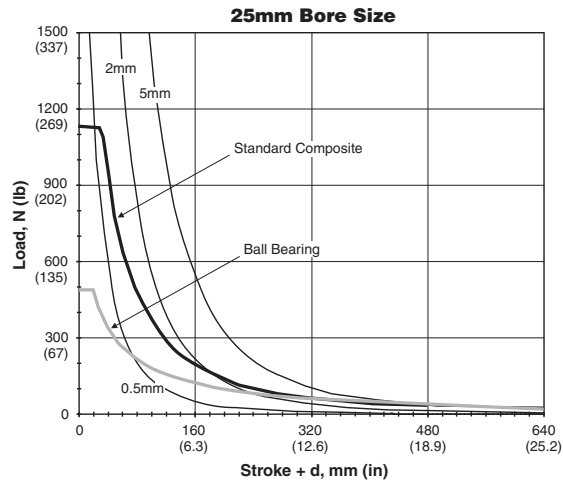
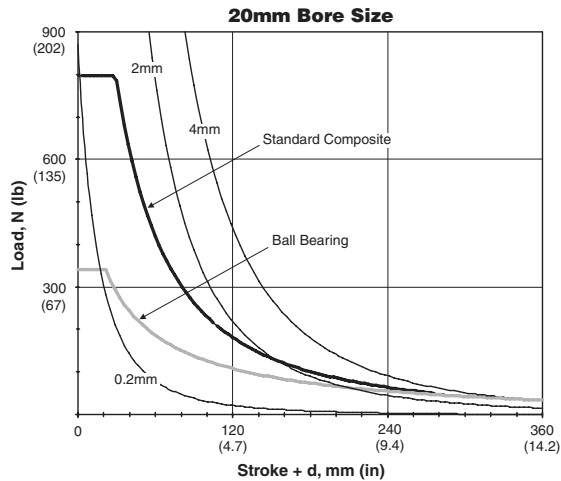
Dynamic loading is defined as a load which is affixed to the actuator tooling plate during the extend or retract motion of the actuator. Capacities are based on bearing and shafts only. Mounting bolts/hardware should be investigated per customer application.

**Note:** The following variables commonly affect the bearing life of a guided cylinder:

- Velocity
- Vibration
- Orientation
- Environment (Dust, moisture, etc.)

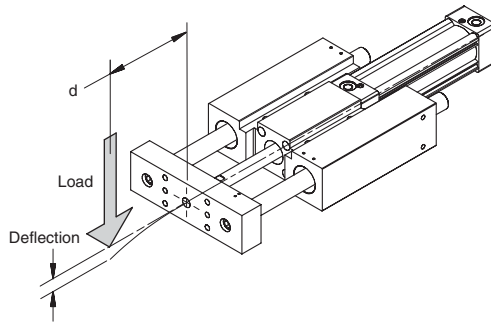
**P5L Reach Slides**

Guided Cylinders	P5T Series	P5L Series	HB Series	P5E Series	XL Series

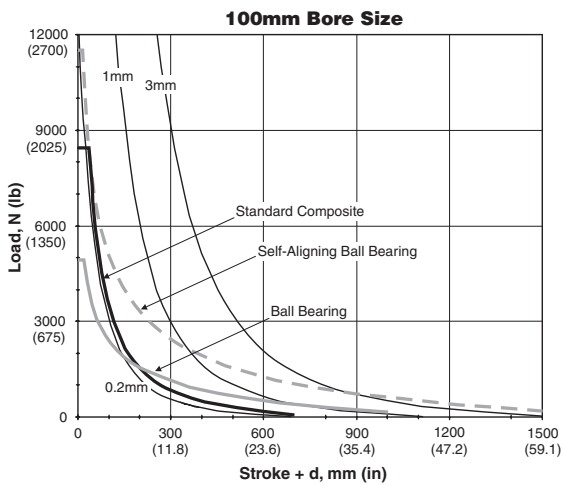
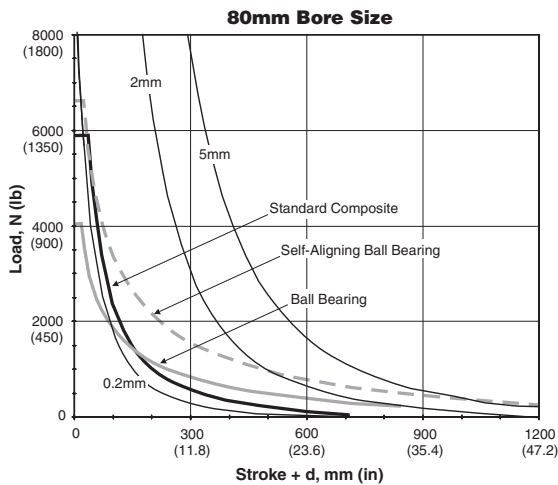
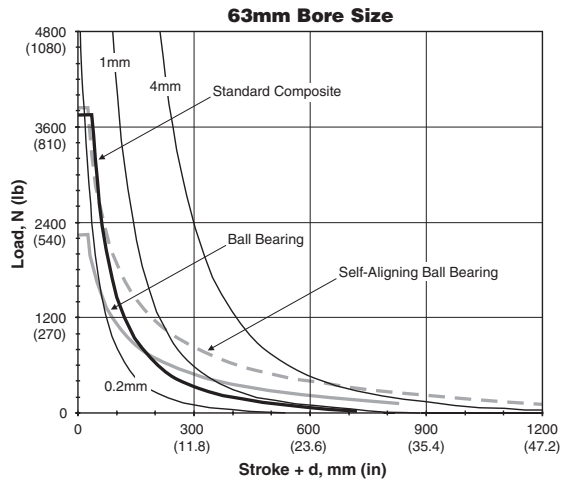
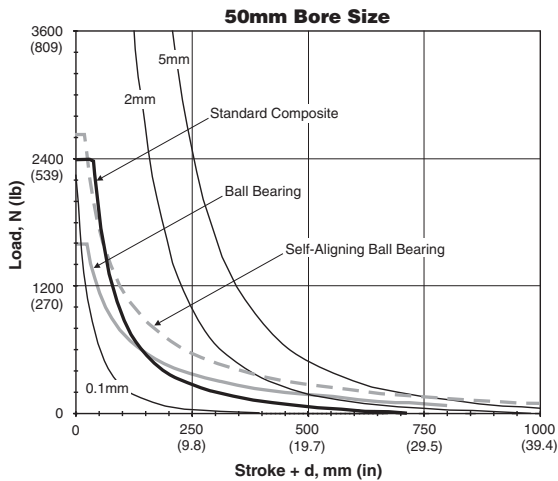


For inventory, lead times, and kit lookup, visit [www.pdnplu.com](http://www.pdnplu.com)

**Horizontal Load Capacity & Deflection with Standard Shafting**



**P5L Reach Slides**



<b>P</b>	Guided Cylinders
P5T Series	P5L Series
HB Series	P5E Series
XL Series	



For inventory, lead time, and kit lookup, visit [www.pdnplu.com](http://www.pdnplu.com)

**Horizontal Load Capacity & Deflection with Oversized Shafting**

- Oversized Composite w/ Chrome Plated or Stainless Steel Rods

The graphs on the following two pages illustrate the maximum suggested side load at a given actuator stroke and distance (d) from the face of the tooling plate. The graphs include the weight of the support rods and tooling plate and are based on a bearing life of 10 million cycles under a dynamic loading condition. For an equivalent static load capacity multiply the information in these graphs by 1.5.

See the P5L options section of this catalog for more bearing selection information.

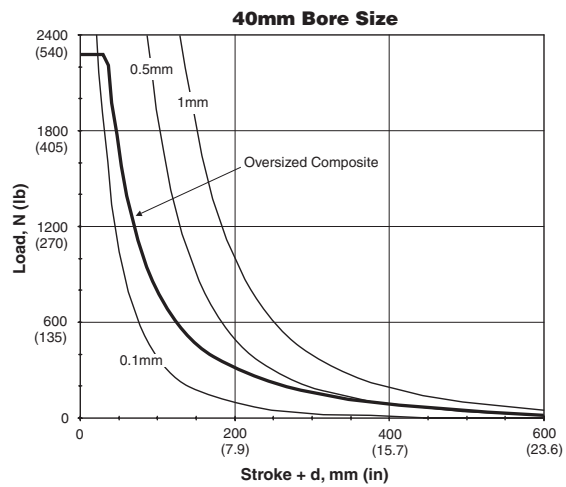
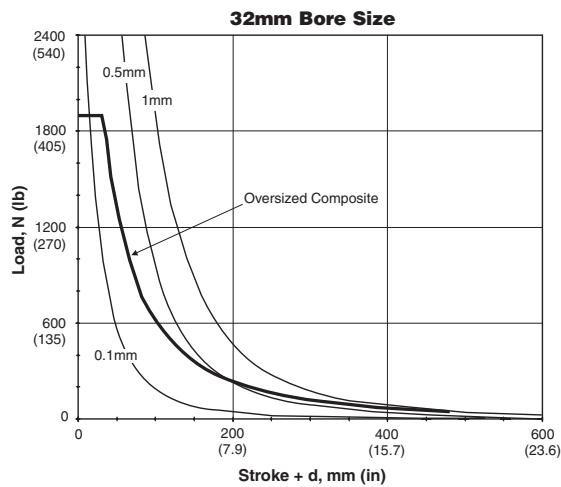
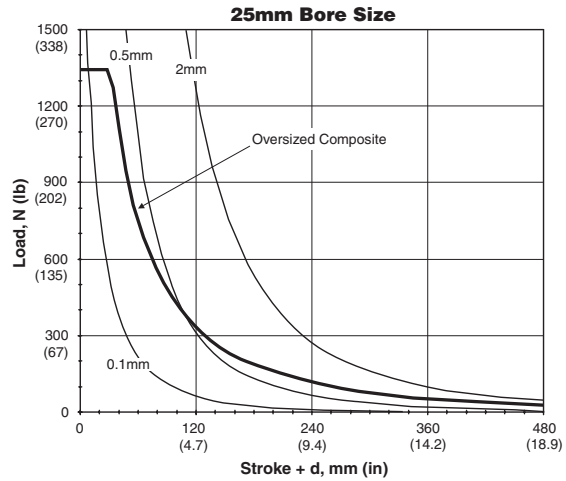
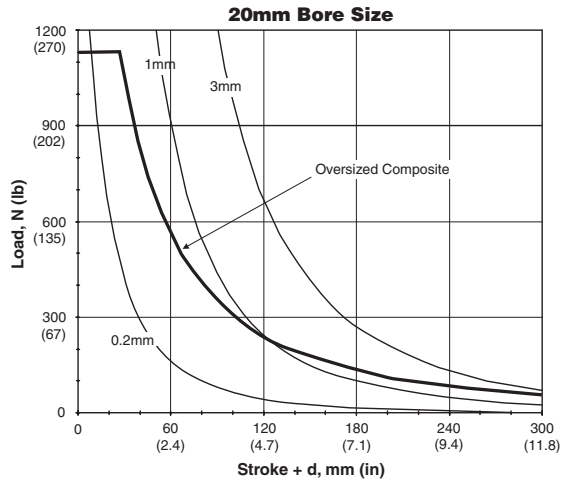
Dynamic loading is defined as a load which is affixed to the actuator tooling plate during the extend or retract motion of the actuator. Capacities are based on bearing and shafts only. Mounting bolts/hardware should be investigated per customer application.

**Note:** The following variables commonly affect the bearing life of a guided cylinder:

- Velocity
- Vibration
- Orientation
- Environment (Dust, moisture, etc.)

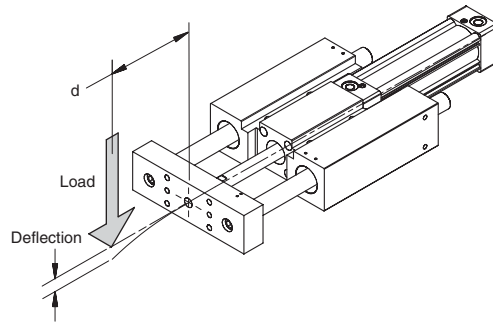
Guided Cylinders	P5T Series
	P5L Series
Series	HB Series
	P5E Series
Series	XL Series

**P5L Reach Slides**

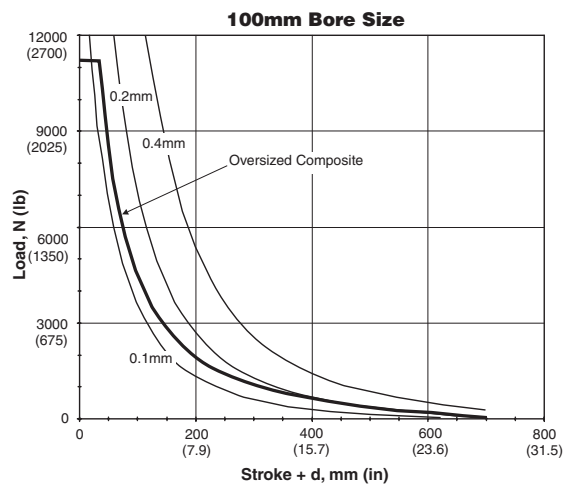
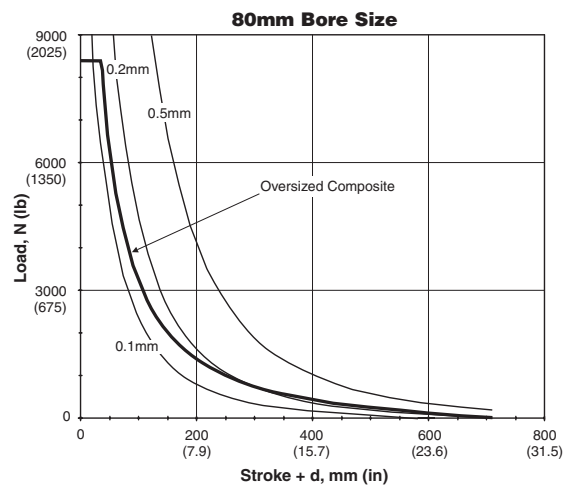
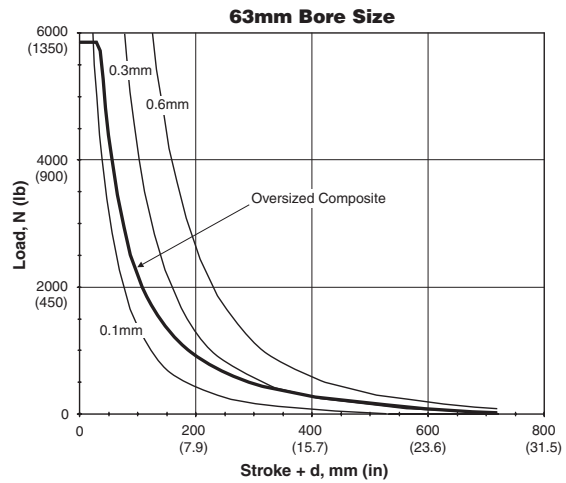
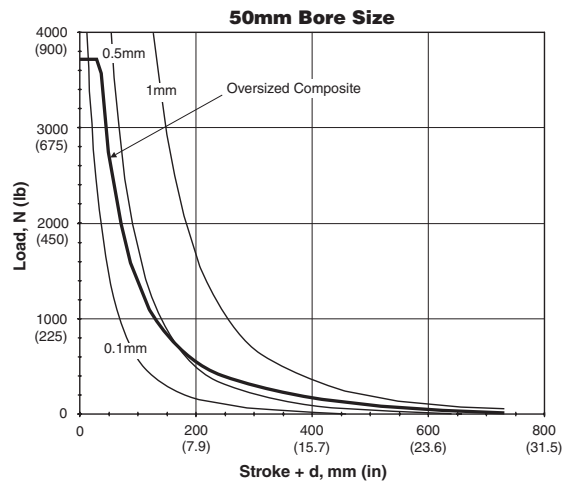


For inventory, lead times, and kit lookup, visit [www.pdnplu.com](http://www.pdnplu.com)

**Horizontal Load Capacity & Deflection with Oversized Shafting**



**P5L Reach Slides**



<b>M</b>
Guided Cylinders
P5T Series
P5L Series
HB Series
P5E Series
XL Series



For inventory, lead time, and kit lookup, visit [www.pdnplu.com](http://www.pdnplu.com)

**Asymmetrical Torque Capacity**


- Standard Composite w/ Chrome Plated or Stainless Steel Rods
- Oversized Composite w/ Chrome Plated or Stainless Steel Rods
- Recirculating Ball Bearings w/ Stainless Steel Rods
- Self Aligning Ball Bearings w/ Stainless Steel Rods

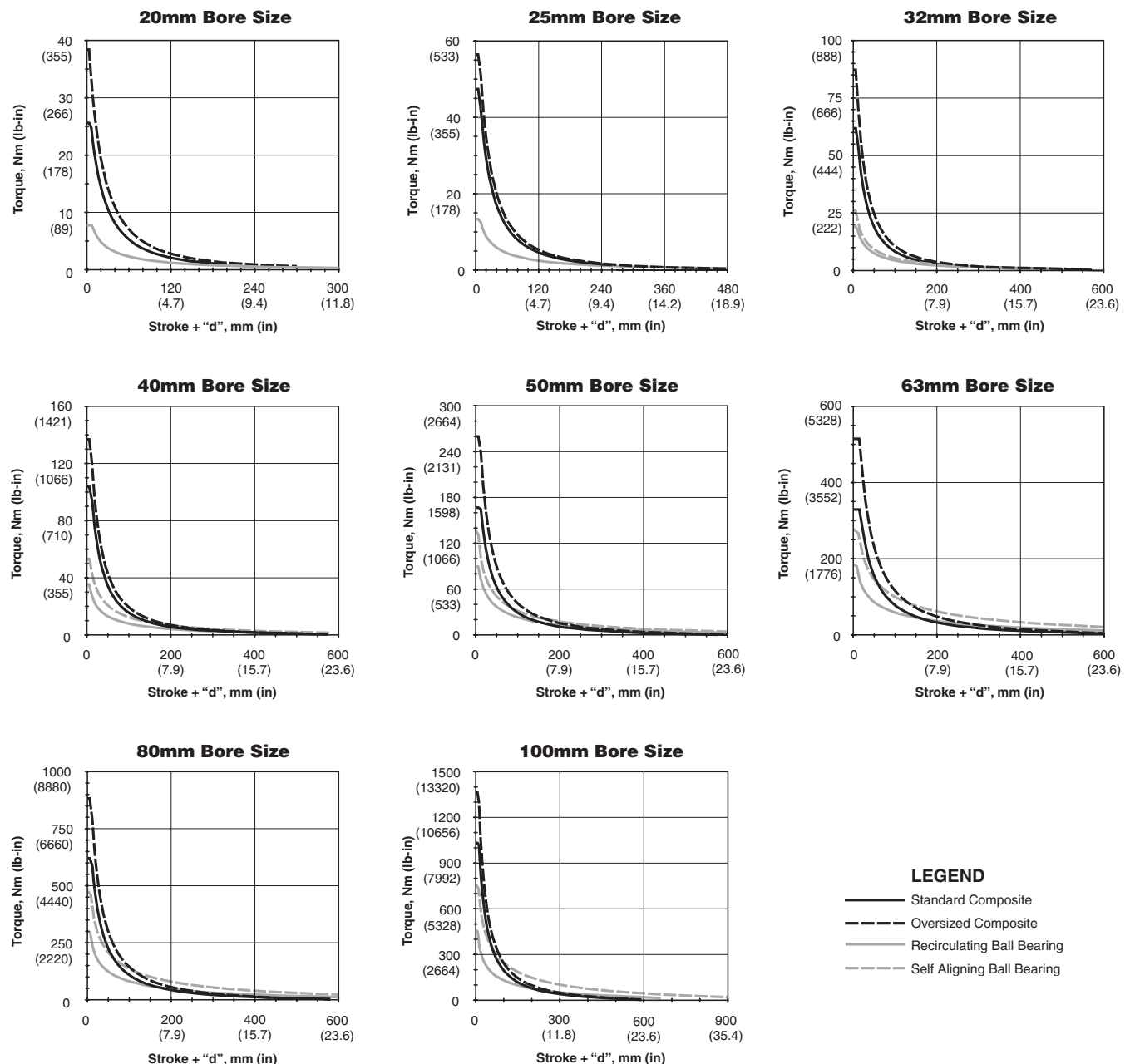
The graphs on the following two pages illustrate the maximum suggested asymmetrical load at a given actuator stroke and distance (d) from the face of the tooling plate. The graphs include the weight of the support rods and tooling plate

and are based on a bearing life of 10 million cycles under a dynamic loading condition. For an equivalent static load capacity multiply the information in these graphs by 1.5.

Dynamic loading is defined as a load which is affixed to the actuator tooling plate during the extend or retract motion of the actuator. Capacities are based on bearing and shafts only. Mounting bolts/hardware should be investigated per customer application. An asymmetrical load is defined as a perpendicular load applied at some horizontal distance, "m" from the center of the tooling plate.

**P5L Thrust Slides**

 Guided Cylinders	P5T Series
	P5L Series
	HB Series
P5E Series	
XL Series	

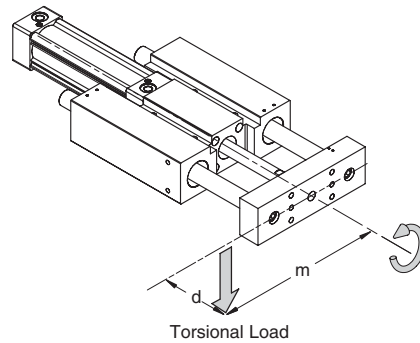


For inventory, lead times, and kit lookup, visit [www.pdnplu.com](http://www.pdnplu.com)

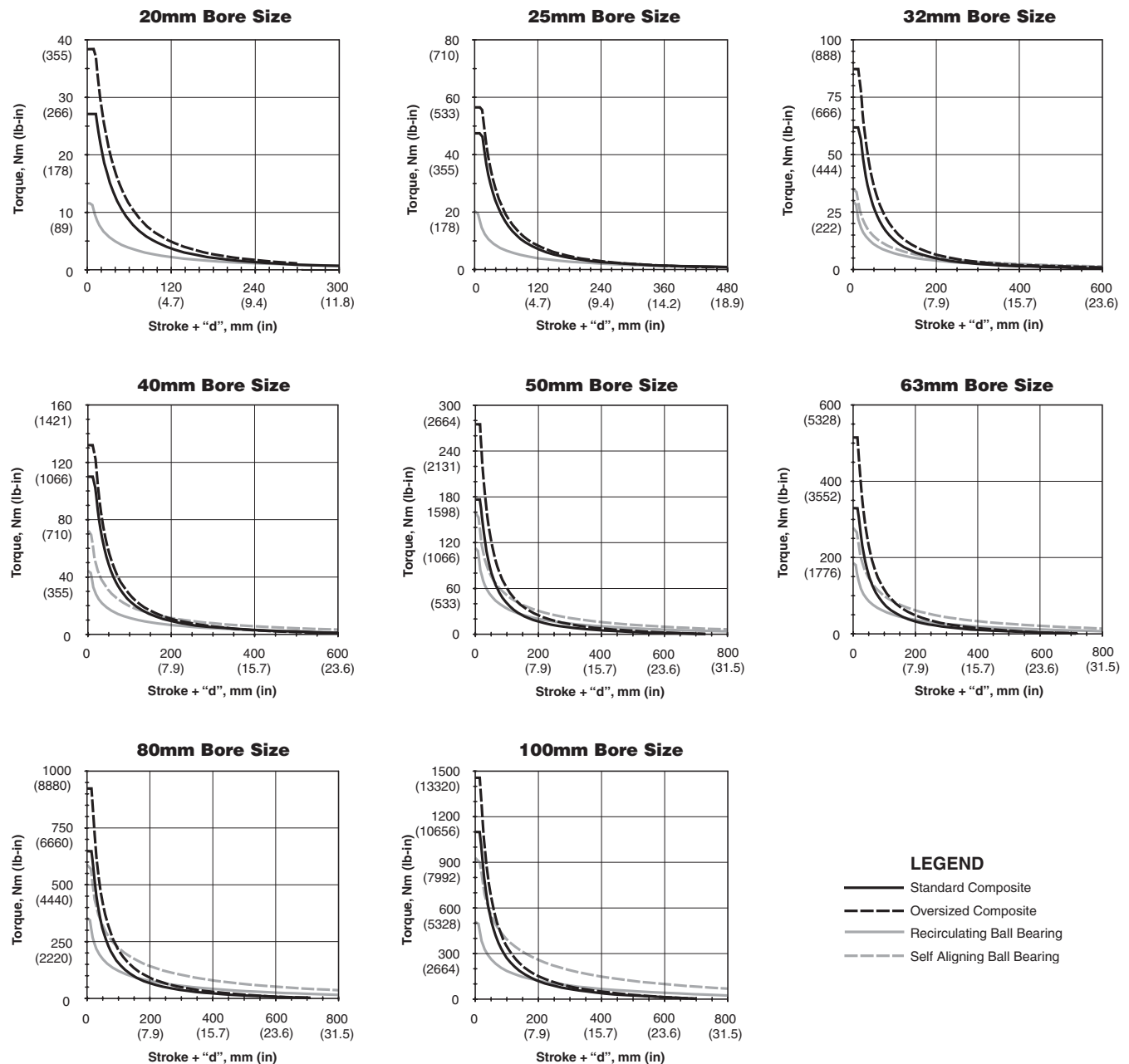
**Asymmetrical Torque Capacity**

**Note:** The following variables commonly affect the bearing life of a guided cylinder:

- Velocity
- Vibration
- Orientation
- Environment (Dust, moisture, etc.)



**P5L Reach Slides**



<b>M</b>
Guided Cylinders
P5T Series
P5L Series
HB Series
P5E Series
XL Series



For inventory, lead time, and kit lookup, visit [www.pdnplu.com](http://www.pdnplu.com)

**Vertical Eccentric Load Capacity**

- Standard Composite w/ Chrome Plated or Stainless Steel Rods
- Oversized Composite w/ Chrome Plated or Stainless Steel Rods
- Recirculating Ball Bearings w/ Stainless Steel Rods
- Self Aligning Ball Bearings w/ Stainless Steel Rods

The graphs on the following two pages illustrate the maximum suggested eccentric load based on a stroke of 100mm (4 inches).

An eccentric load is defined as a load applied in the same direction as the motion of the cylinder however, acting at some

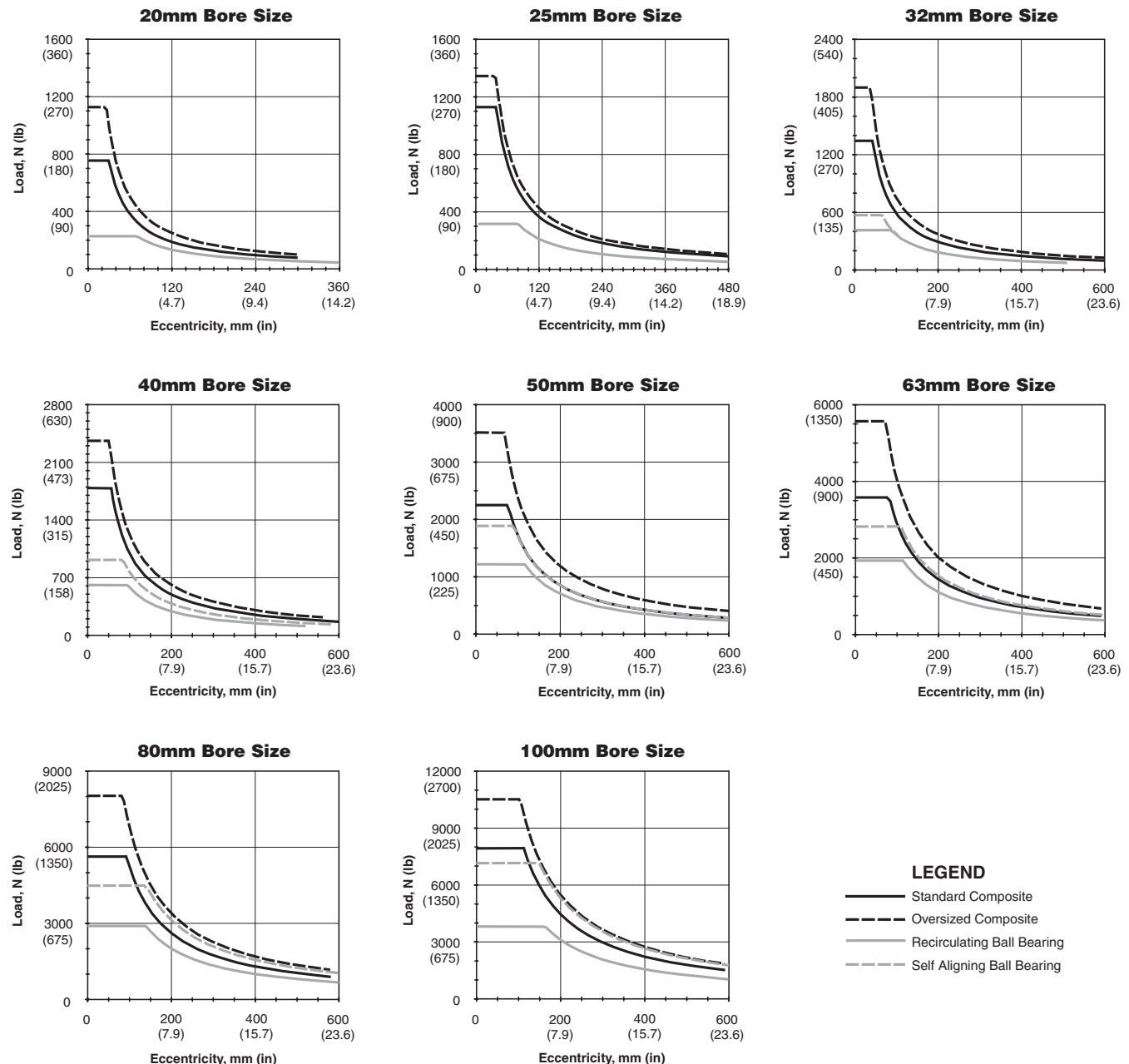
distance (eccentricity "h") from the center of the tooling plate. Capacities are based on bearing and shafts only. Mounting bolts/hardware should be investigated per customer application.

**Note:** The following variables commonly affect the bearing life of a guided cylinder:

- Velocity
- Vibration
- Orientation
- Environment (Dust, moisture, etc.)

**P5L Thrust Slides**

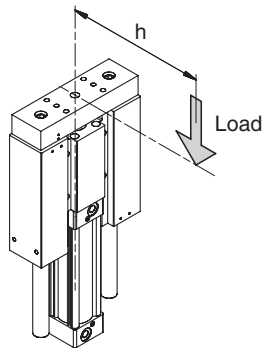
Guided Cylinders	P5L Series	P5L Series	HB Series	P5E Series	XL Series



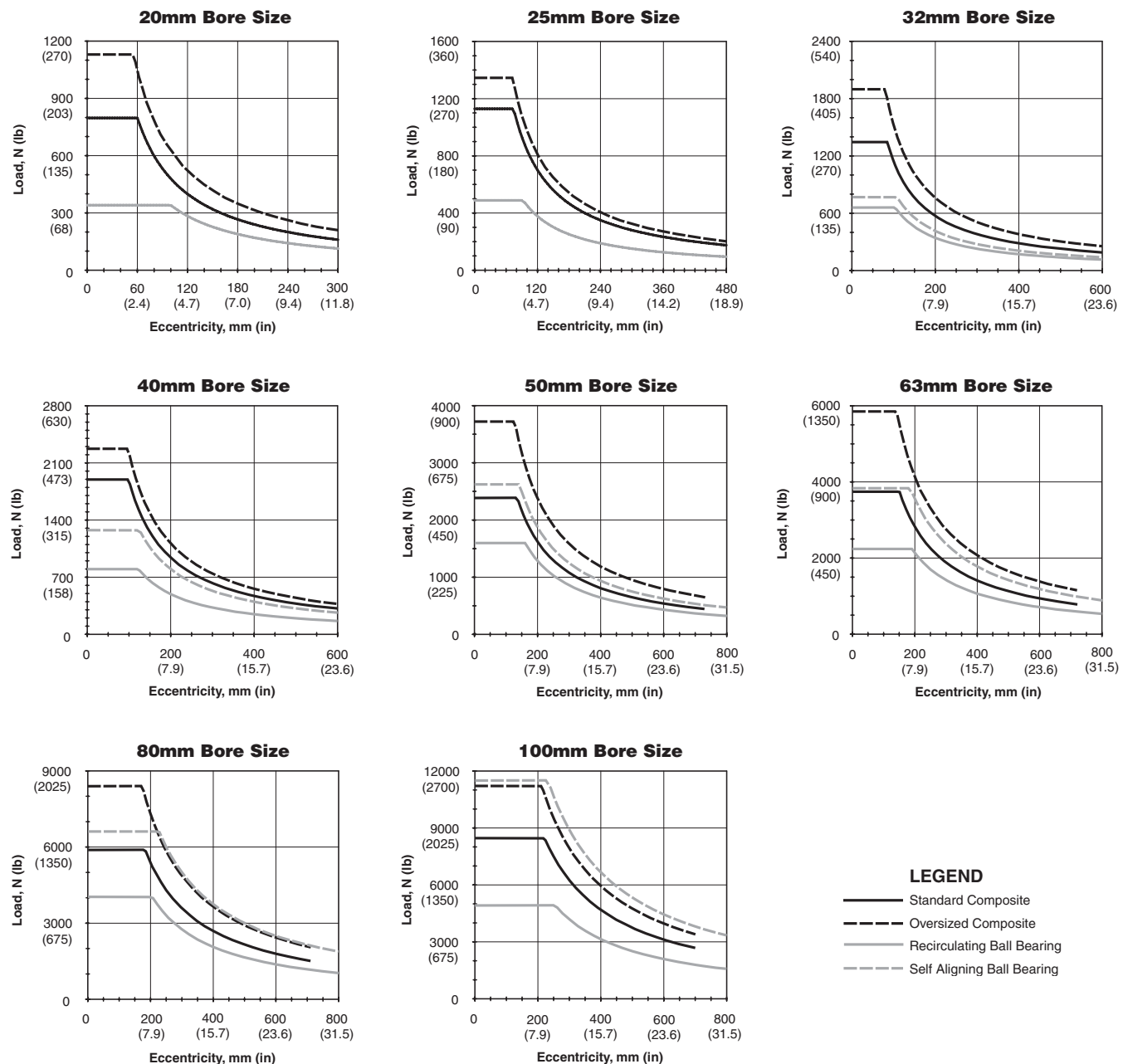
For inventory, lead times, and kit lookup, visit [www.pdnplu.com](http://www.pdnplu.com)



**Vertical Eccentric Load Capacity**



**P5L Reach Slides**



	Guided Cylinders
	P5T Series
P5L Series	
HB Series	
P5E Series	
XL Series	



For inventory, lead time, and kit lookup, visit [www.pdnplu.com](http://www.pdnplu.com)

**Load Stopping Capacity**

- Standard Composite w/ Chrome Plated or Stainless Steel Rods
- Oversized Composite w/ Chrome Plated or Stainless Steel Rods

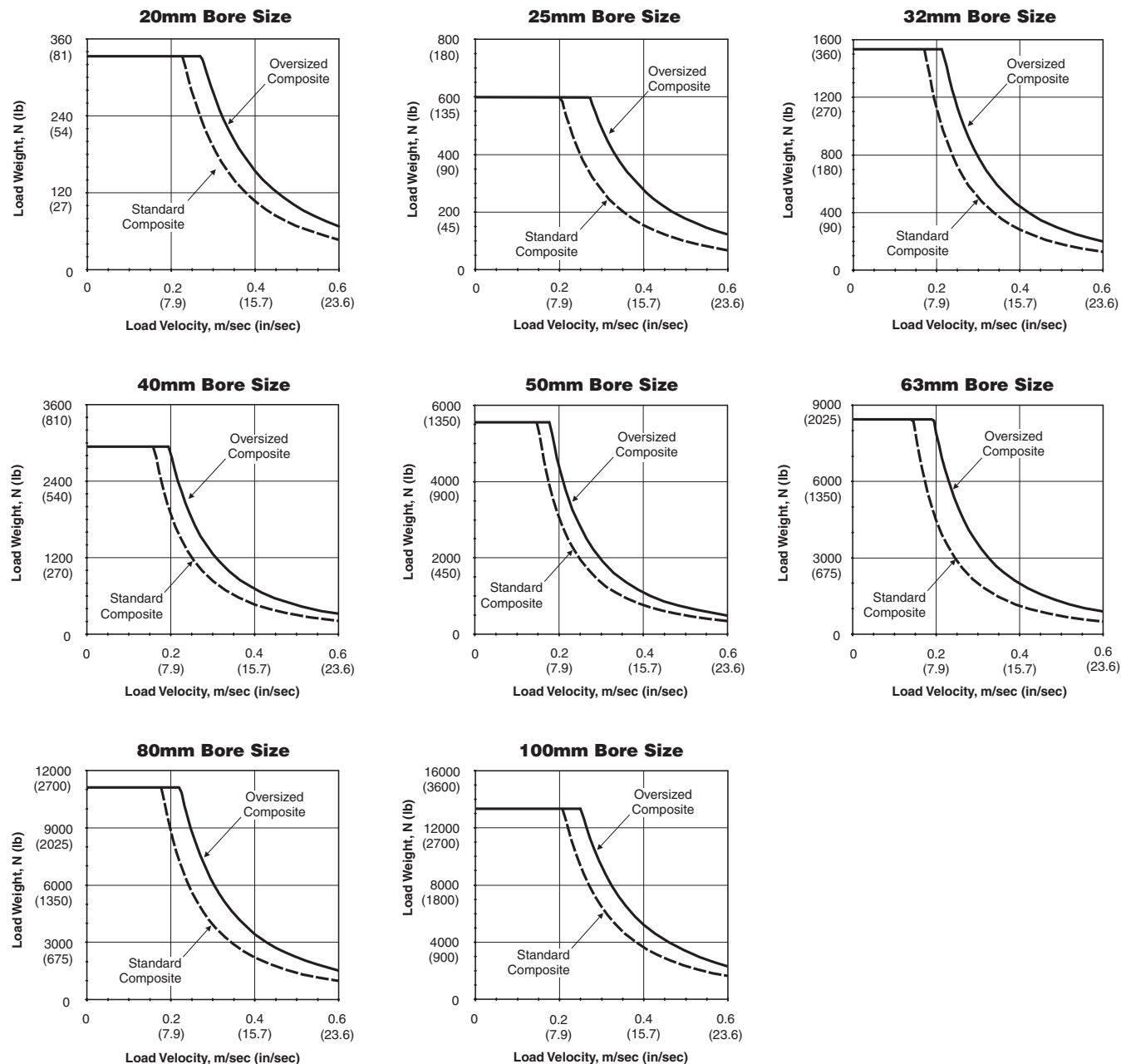
The P5L series can be used in conveyor stopping applications. The graphs on these two pages illustrate the maximum stopping capacity for the P5L Series. The maximum stopping capacity will vary with actuator stroke. These graphs are based on a stroke of 50mm (2 inches), assuming that the

moving load is moving perpendicularly to the support rods. Care should be taken to ensure that the support rods are not damaged during this type of loading. The load should also be centered on the tooling plate.

**Note:** Ball bearings should not be used in this type of application.

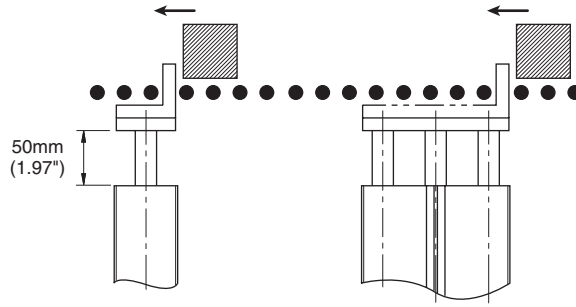
**P5L Thrust Slides**

Guided Cylinders	P5T Series	P5L Series	HB Series	P5E Series	XL Series

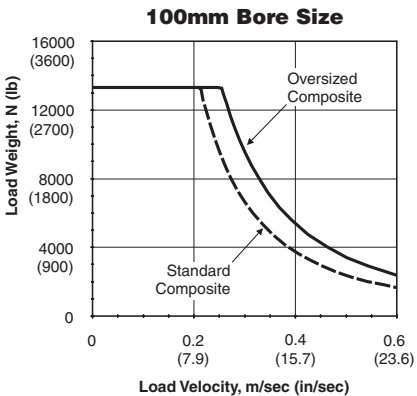
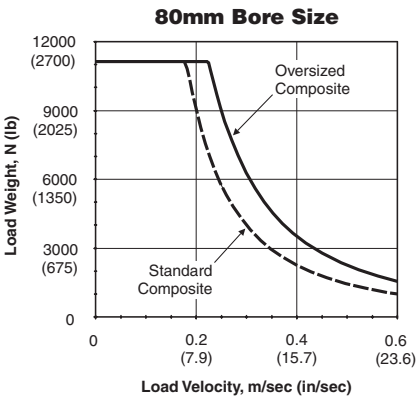
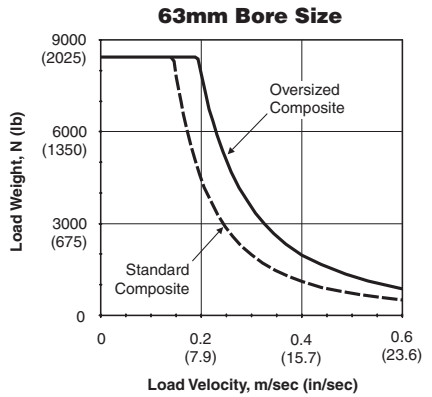
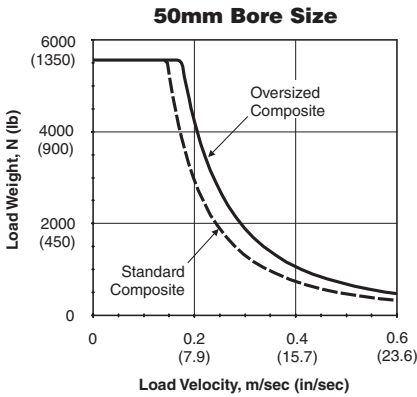
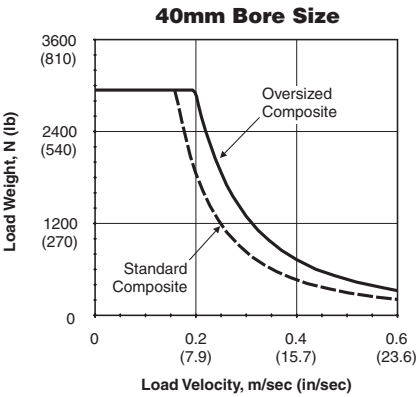
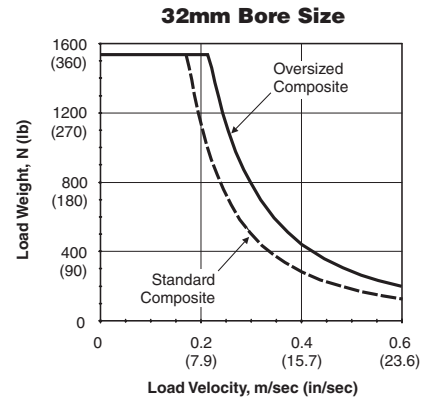
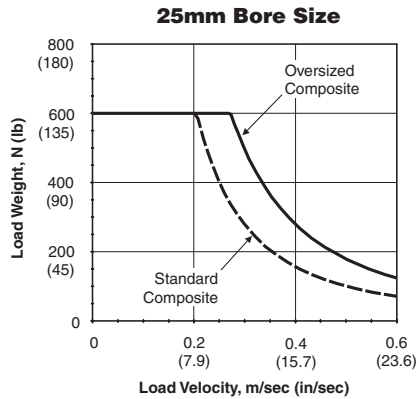
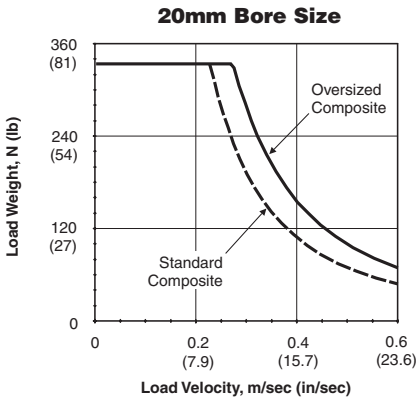


For inventory, lead times, and kit lookup, visit [www.pdnplu.com](http://www.pdnplu.com)

**Load Stopping Capacity**



**P5L Reach Slides**



<b>P</b>
Guided Cylinders
P5T Series
P5L Series
HB Series
P5E Series
XL Series



For inventory, lead time, and kit lookup, visit [www.pdnplu.com](http://www.pdnplu.com)

**Kinetic Energy**

These graphs illustrate the kinetic energy absorption of the P5L series as a total moving weight versus speed chart for both air cushions and shock absorbers.

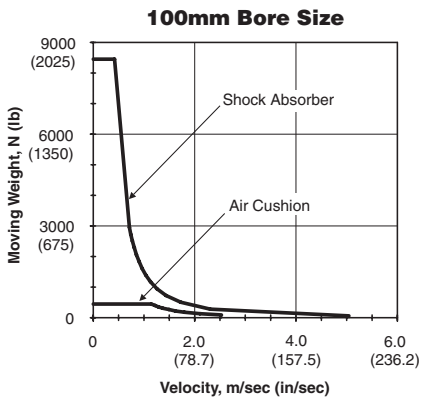
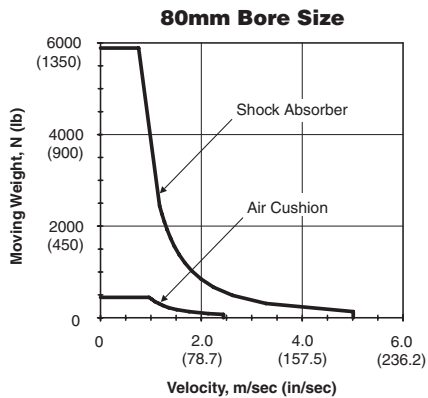
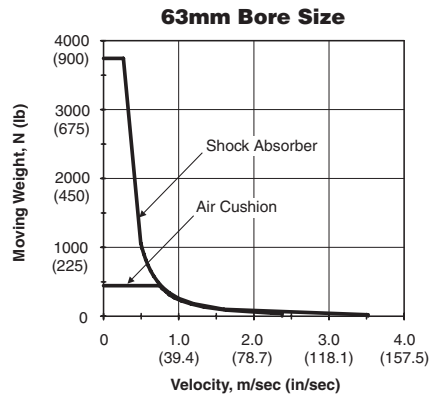
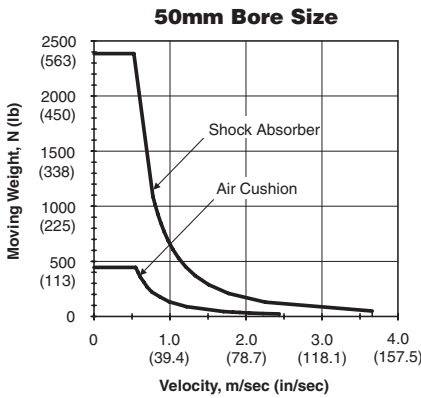
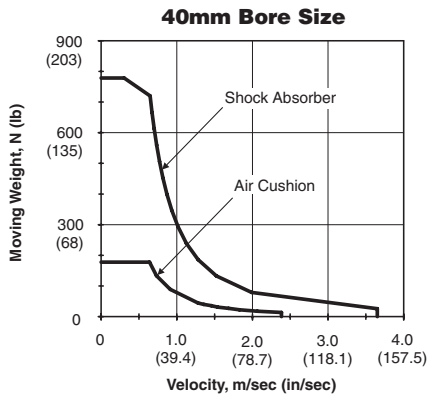
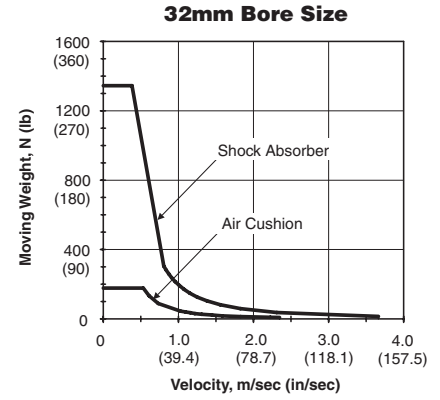
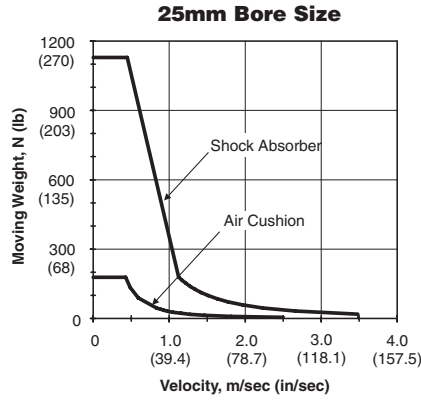
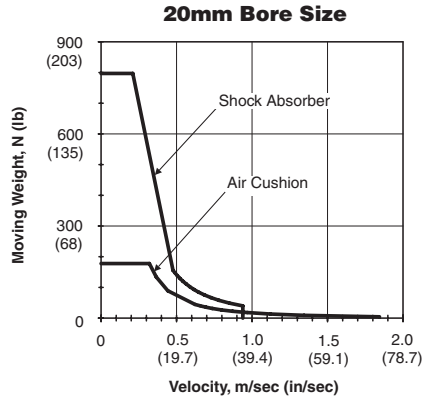
Moving weight is defined as the weight of the carried load and the weight of any moving parts of the actuator (support rods, tooling plate, etc.). The moving weight from the charts on next page should be considered.

Actuator Moving Weight =  
 Base Unit Weight + (Stroke × Per Inch Weight)  
 Total Moving Weight =  
 Actuator Moving Weight + Carried Load

**Note:** These charts are to be used only to determine the energy absorption of each guided cylinder and to determine if shocks or cushions are needed.

**P5L Thrust Slides**

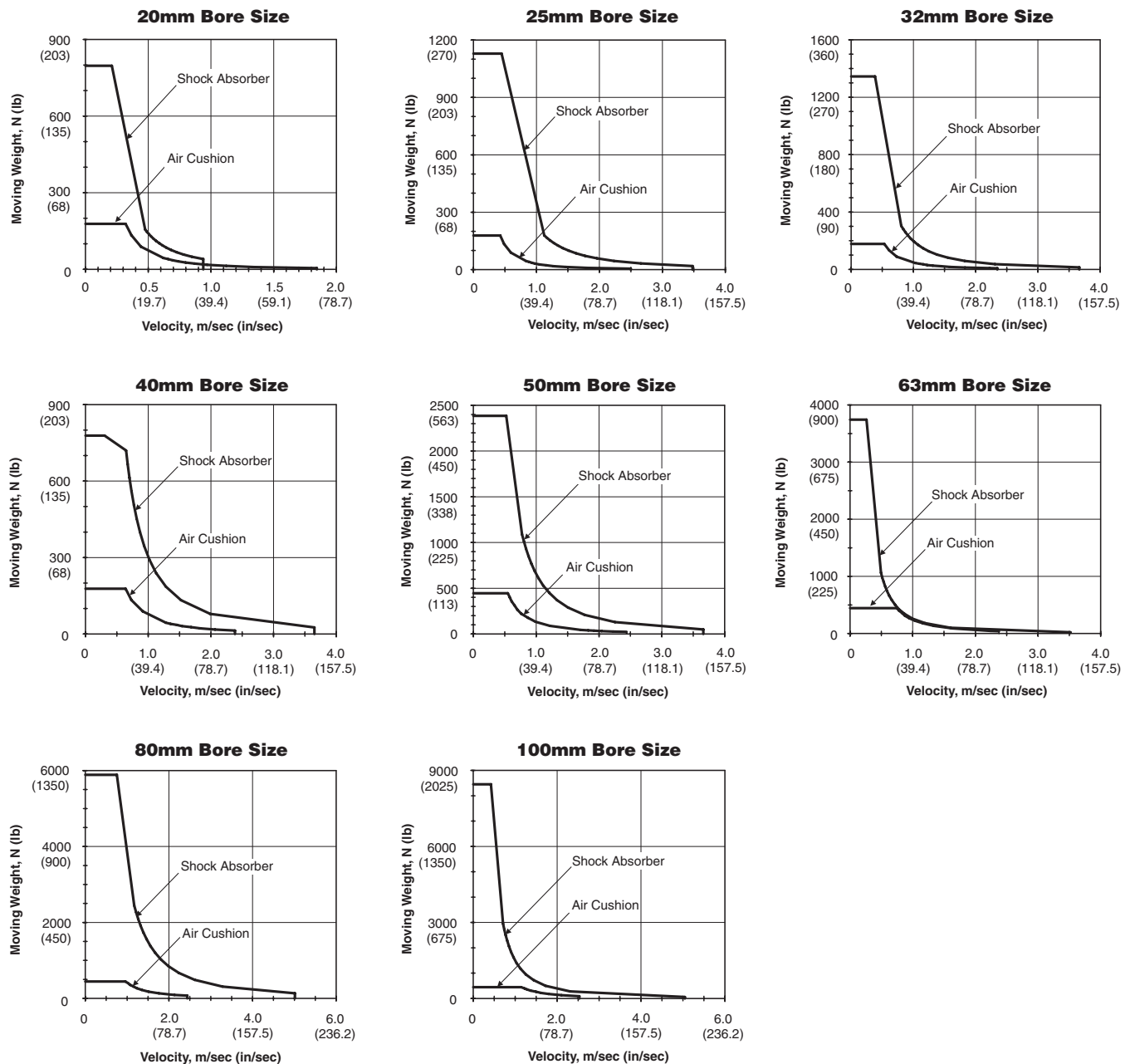
Guided Cylinders	P5T Series	P5L Series	HB Series	P5E Series	XL Series



For inventory, lead times, and kit lookup, visit [www.pdnplu.com](http://www.pdnplu.com)

Bore	Moving weights (standard shaft)						Moving weights (oversized shaft)					
	Basic thrust unit		Basic reach unit		Per inch		Basic thrust unit		Basic reach unit		Per inch	
	kg	lbs	kg	lbs	kg	lbs	kg	lbs	kg	lbs	kg	lbs
20	0.27	0.6	0.32	0.7	0.02	0.05	0.35	0.8	0.43	0.96	0.03	0.07
25	0.45	1.0	0.53	1.2	0.03	0.07	0.68	1.5	0.85	1.88	0.06	0.13
32	0.78	1.7	0.95	2.1	0.06	0.13	1.15	2.5	1.45	3.20	0.09	0.21
40	1.4	3.2	1.7	3.8	0.09	0.21	2.2	4.7	2.82	6.2	0.15	0.32
50	2.8	6.1	3.4	7.5	0.15	0.32	4.0	8.8	5.21	11.5	0.21	0.47
63	4.7	10.5	6.0	13.2	0.21	0.47	7.5	16.6	10.27	22.6	0.38	0.83
80	9.0	19.7	11.7	25.8	0.26	0.58	13.9	30.7	19.08	42.1	0.59	1.29
100	16.4	36.2	21.6	47.6	0.59	1.29	18.1	40.0	25.57	56.4	0.84	1.86

**P5L Reach Slides**



**M**  
**Guided Cylinders**

P5T Series

**P5L Series**

HB Series

P5E Series

XL Series



For inventory, lead time, and kit lookup, visit [www.pdnplu.com](http://www.pdnplu.com)

E41

**Parker Hannifin Corporation**  
 Pneumatic Division  
 Richland, Michigan  
[www.parker.com/pneumatics](http://www.parker.com/pneumatics)

**Horizontal Load Capacity & Deflection with Standard Shafting**

- Standard Composite w/ Chrome Plated or Stainless Steel Rods
- Recirculating Ball Bearings w/ Stainless Steel Rods
- Self Aligning Ball Bearings w/ Stainless Steel Rods

The graphs on the following two pages illustrate the maximum suggested side load at a given actuator stroke. The graphs include the weight of the carriage and are based on a bearing life of 10 million cycles under a dynamic loading condition. For an equivalent static load capacity multiply the information in these graphs by 1.5.

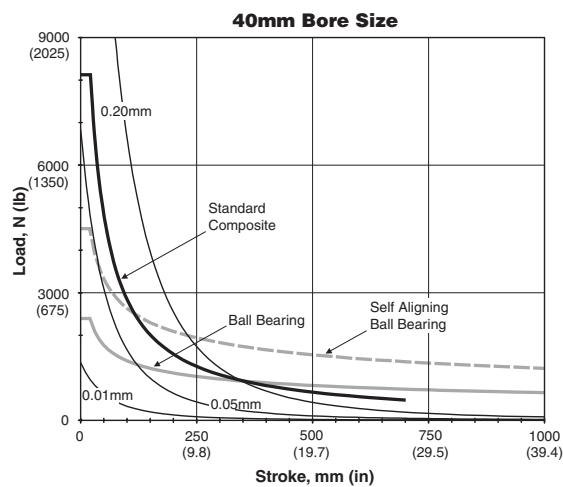
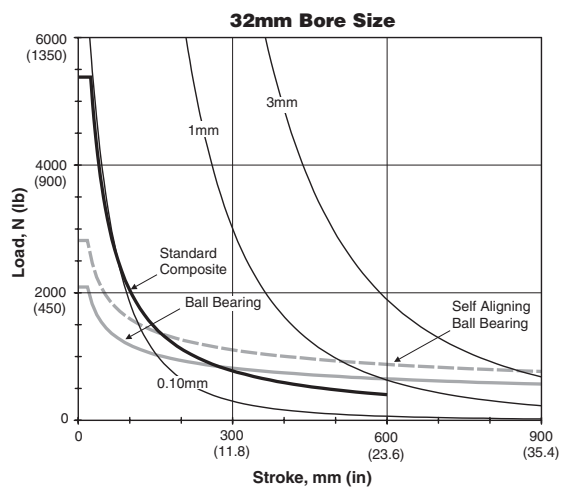
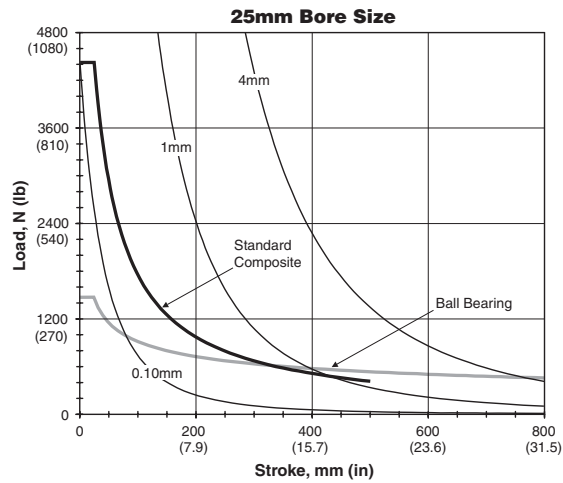
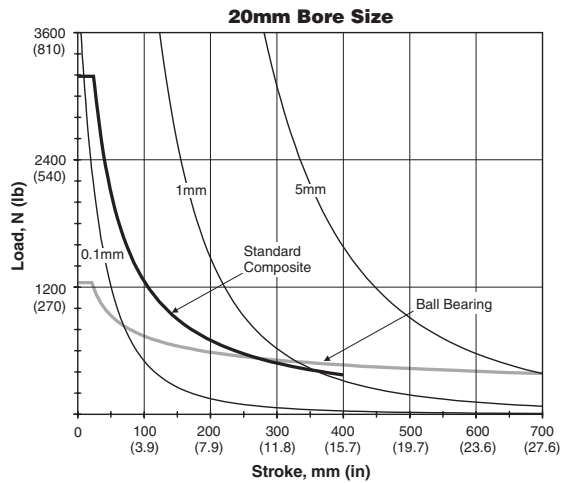
See the P5L options section of this catalog for more bearing selection information.

Dynamic loading is defined as a load which is affixed to the actuator tooling plate during the extend or retract motion of the actuator. Capacities are based on bearing and shafts only. Mounting bolts/hardware should be investigated per customer application.

**Note:** The following variables commonly affect the bearing life of a guided cylinder:

- Velocity
- Vibration
- Orientation
- Environment (Dust, moisture, etc.)

**P5L Base Slides**

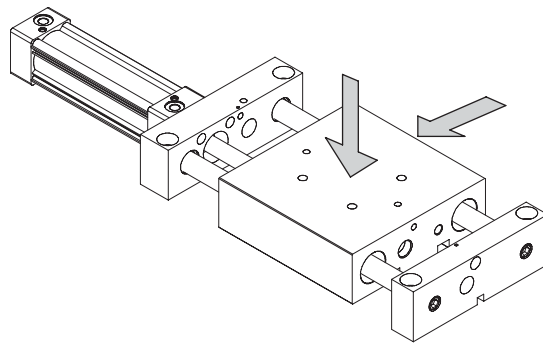


Guided Cylinders	P5T Series
	P5L Series
Series	HB Series
	P5E Series
Series	XL Series

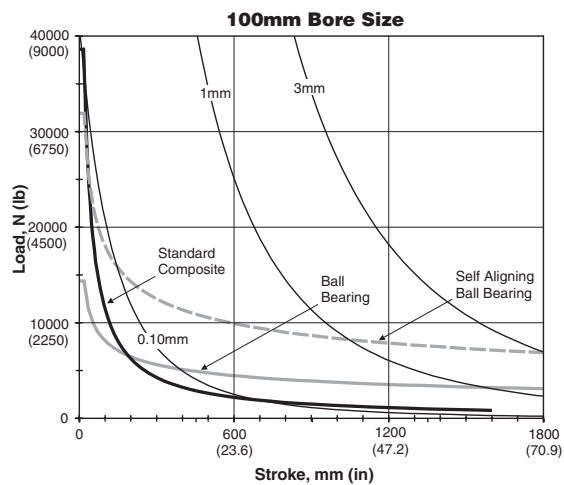
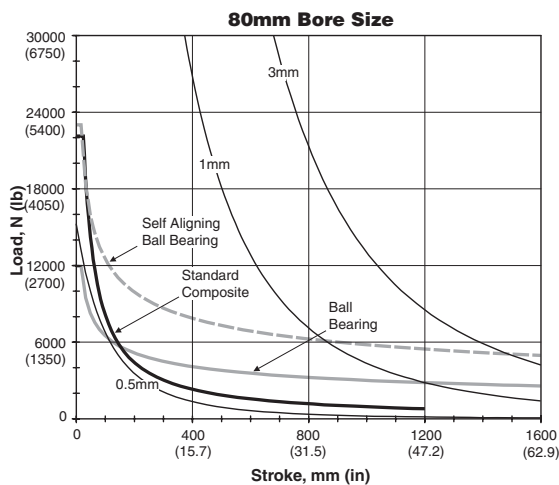
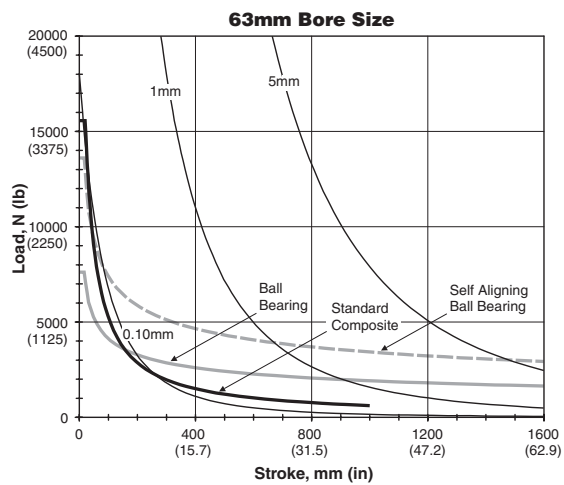
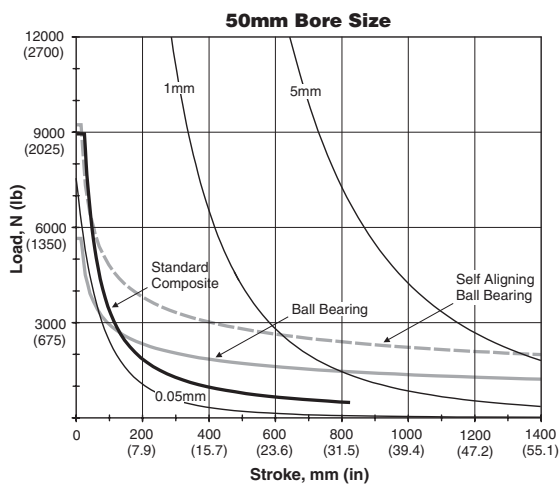


For inventory, lead times, and kit lookup, visit [www.pdnplu.com](http://www.pdnplu.com)

**Horizontal Load Capacity & Deflection with Standard Shafting**



**P5L Base Slides**



<b>P</b>
Guided Cylinders
P5T Series
P5L Series
HB Series
P5E Series
XL Series



For inventory, lead time, and kit lookup, visit [www.pdnplu.com](http://www.pdnplu.com)

**Horizontal Load Capacity & Deflection with Oversized Shafting**

- Oversized Composite w/ Chrome Plated or Stainless Steel Rods

The graphs on the following two pages illustrate the maximum suggested side load at a given actuator stroke. The graphs include the weight of the carriage and are based on a bearing life of 10 million cycles under a dynamic loading condition. For an equivalent static load capacity multiply the information in these graphs by 1.5.

See the P5L options section of this catalog for more bearing selection information.

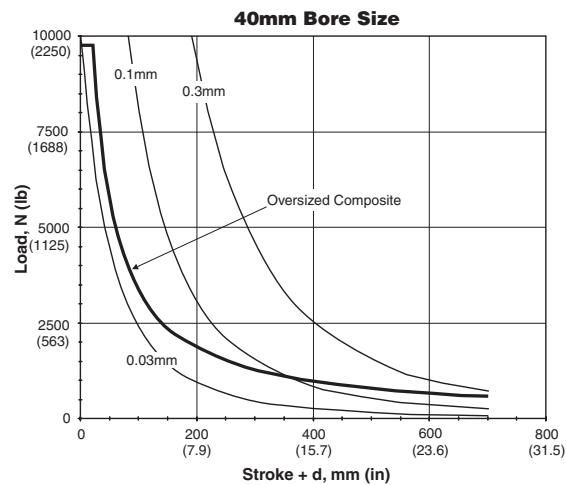
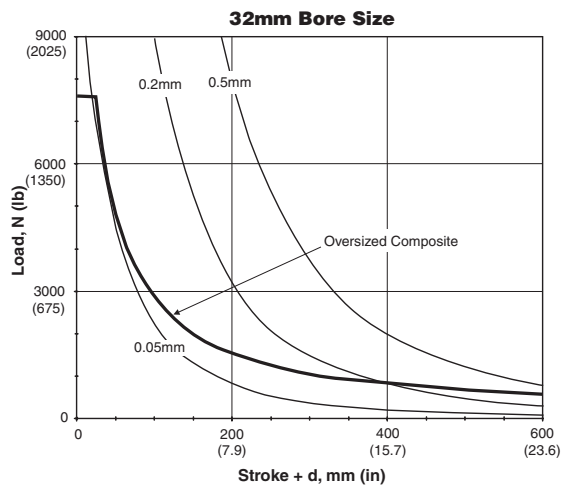
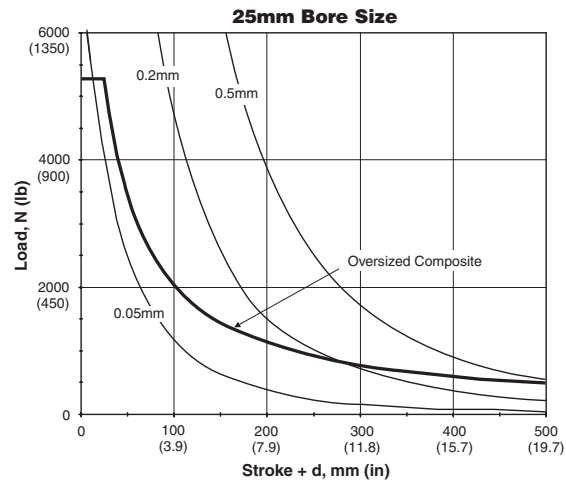
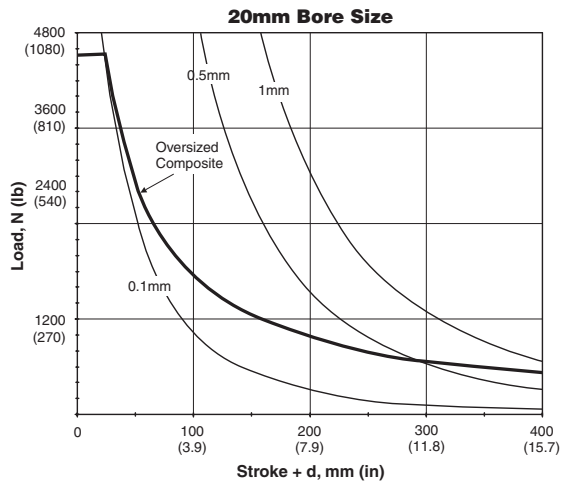
Dynamic loading is defined as a load which is affixed to the actuator tooling plate during the extend or retract motion of the actuator. Capacities are based on bearing and shafts only. Mounting bolts/hardware should be investigated per customer application.

**Note:** The following variables commonly affect the bearing life of a guided cylinder:

- Velocity
- Vibration
- Orientation
- Environment (Dust, moisture, etc.)

**P5L Base Slides**

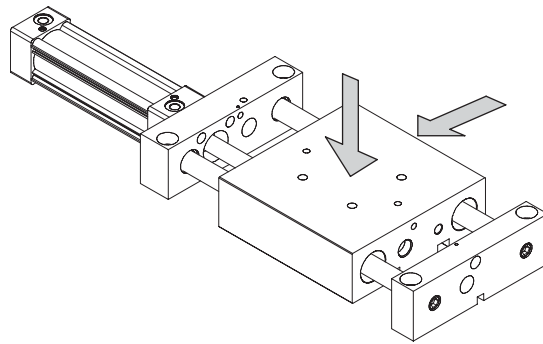
<b>W</b>	Guided Cylinders
P5T Series	
P5L Series	
HB Series	
P5E Series	
XL Series	



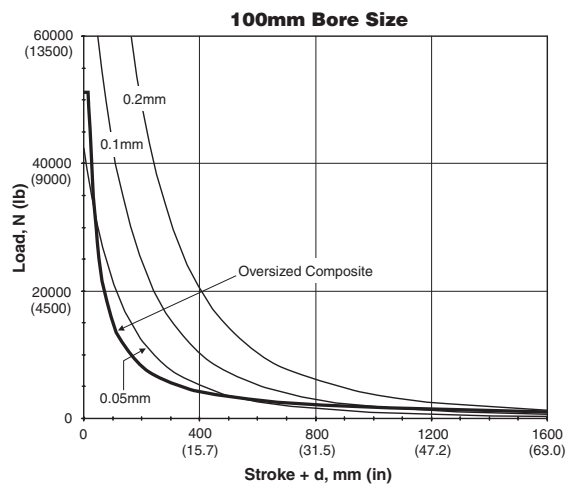
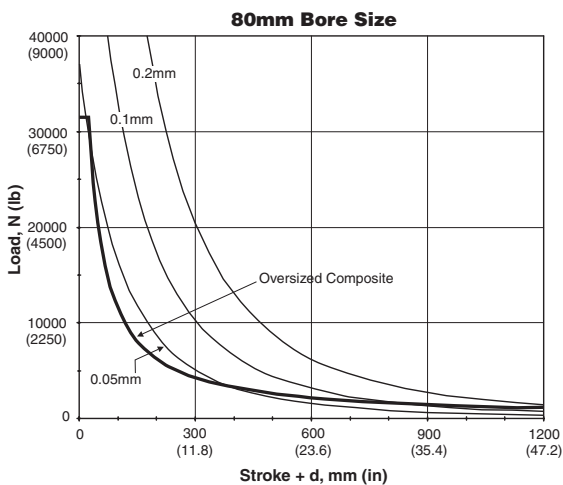
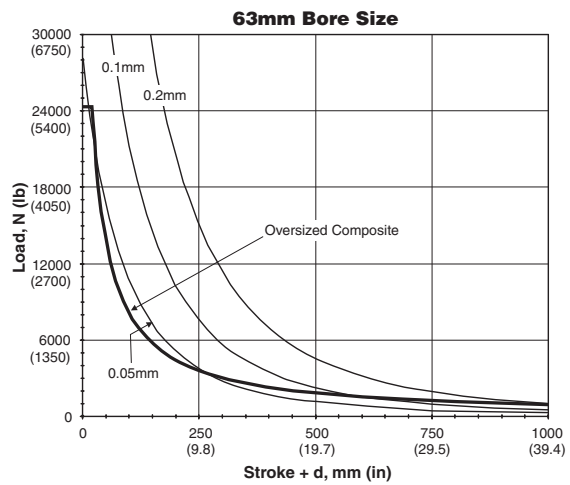
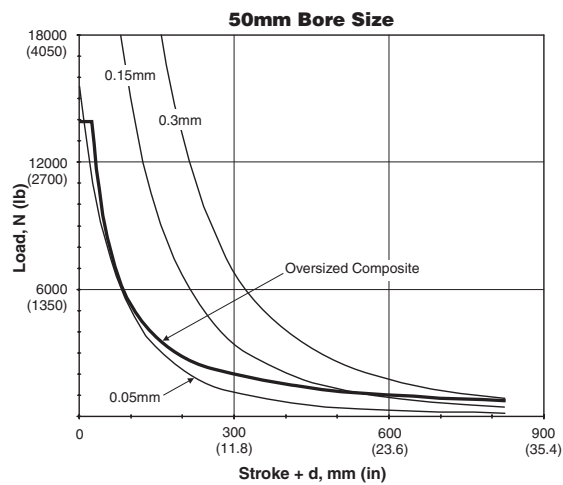
For inventory, lead times, and kit lookup, visit [www.pdnplu.com](http://www.pdnplu.com)



**Horizontal Load Capacity & Deflection with Oversized Shafting**



**P5L Base Slides**



<b>P</b>
Guided Cylinders
P5T Series
P5L Series
HB Series
P5E Series
XL Series



For inventory, lead time, and kit lookup, visit [www.pdnplu.com](http://www.pdnplu.com)

**Symmetrical Roll Torsional Loading**

The graphs on the following two pages illustrate the maximum suggested roll load at a given actuator stroke. It is assumed that the moment loading is acting about the centerline of the carriage. The graphs include the weight of the carriage and are based on a bearing life of 10 million cycles under a dynamic loading condition. Capacities are based on bearing and shafts only. Mounting bolts/hardware should be investigated per customer application. For an equivalent static load capacity multiply the information in these graphs by 1.5.

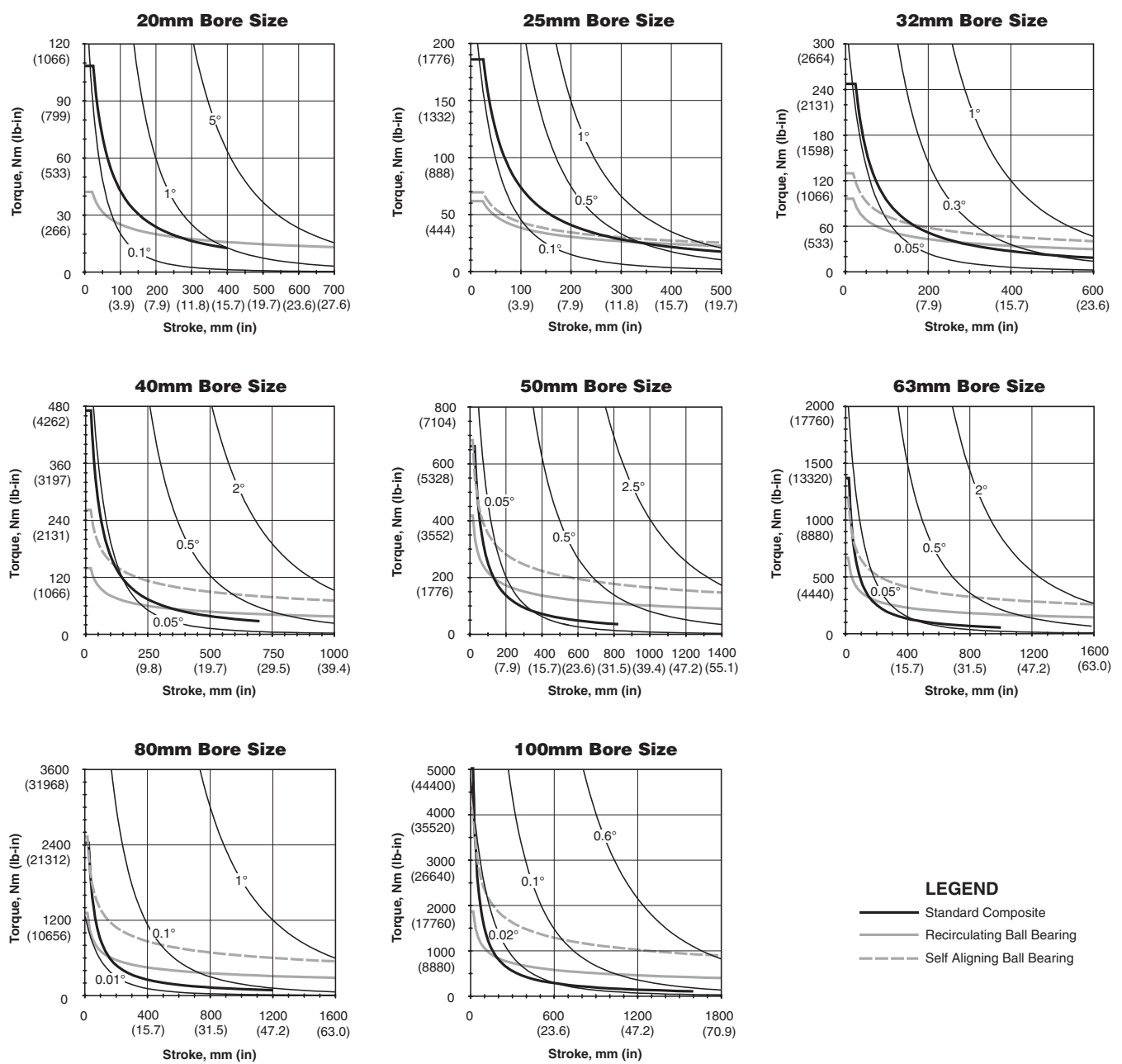
Heavy lines show loading; lighter lines show various degrees of deflection.

**Note:** The following variables commonly affect the bearing life of a guided cylinder:

- Velocity
- Vibration
- Orientation
- Environment (Dust, moisture, etc.)

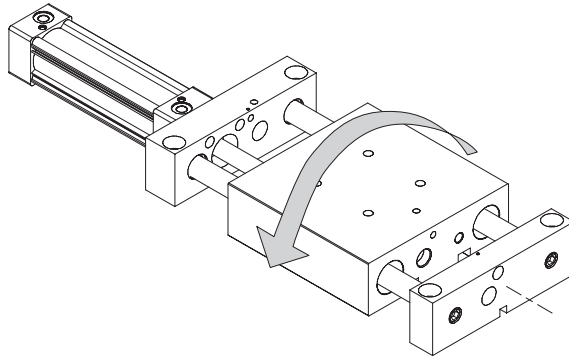
**Standard Shafting**

**Guided Cylinders**  
 P5T Series  
 P5L Series  
 HB Series  
 P5E Series  
 XL Series

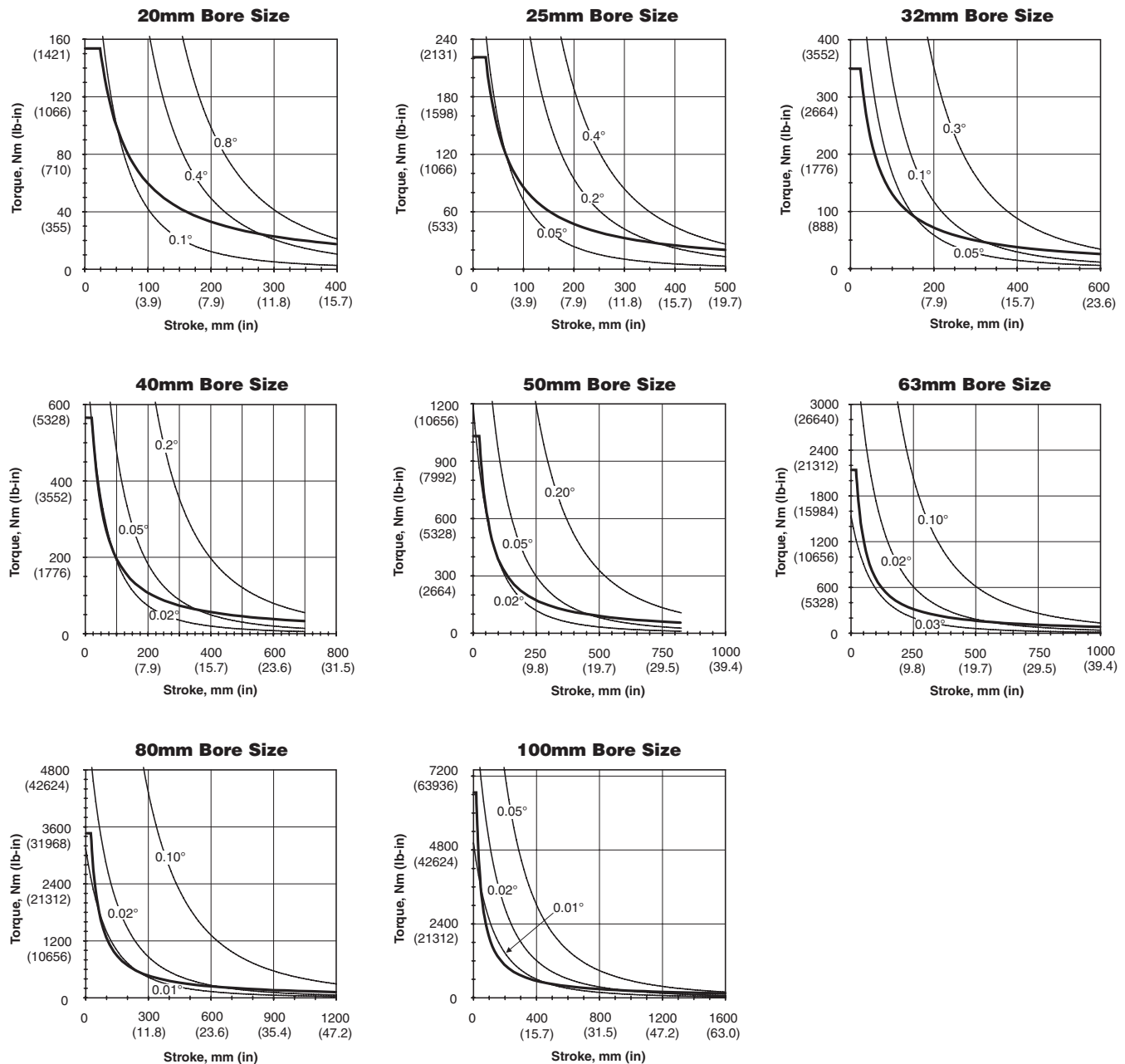


For inventory, lead times, and kit lookup, visit [www.pdnplu.com](http://www.pdnplu.com)

**Symmetrical Roll Torsional Loading**



**Oversized Shafting**



	Guided Cylinders
	P5T Series
P5L Series	
HB Series	
P5E Series	
XL Series	



For inventory, lead time, and kit lookup, visit [www.pdnplu.com](http://www.pdnplu.com)

**Symmetrical Pitch Torsional Loading**

The graphs on the following two pages illustrate the maximum suggested pitch load at a given actuator stroke. It is assumed that the moment loading is acting about the centerline of the carriage. The graphs include the weight of the carriage and are based on a bearing life of 10 million cycles under a dynamic loading condition. Capacities are based on bearing and shafts only. Mounting bolts/hardware should be investigated per customer application. For an equivalent static load capacity multiply the information in these graphs by 1.5.

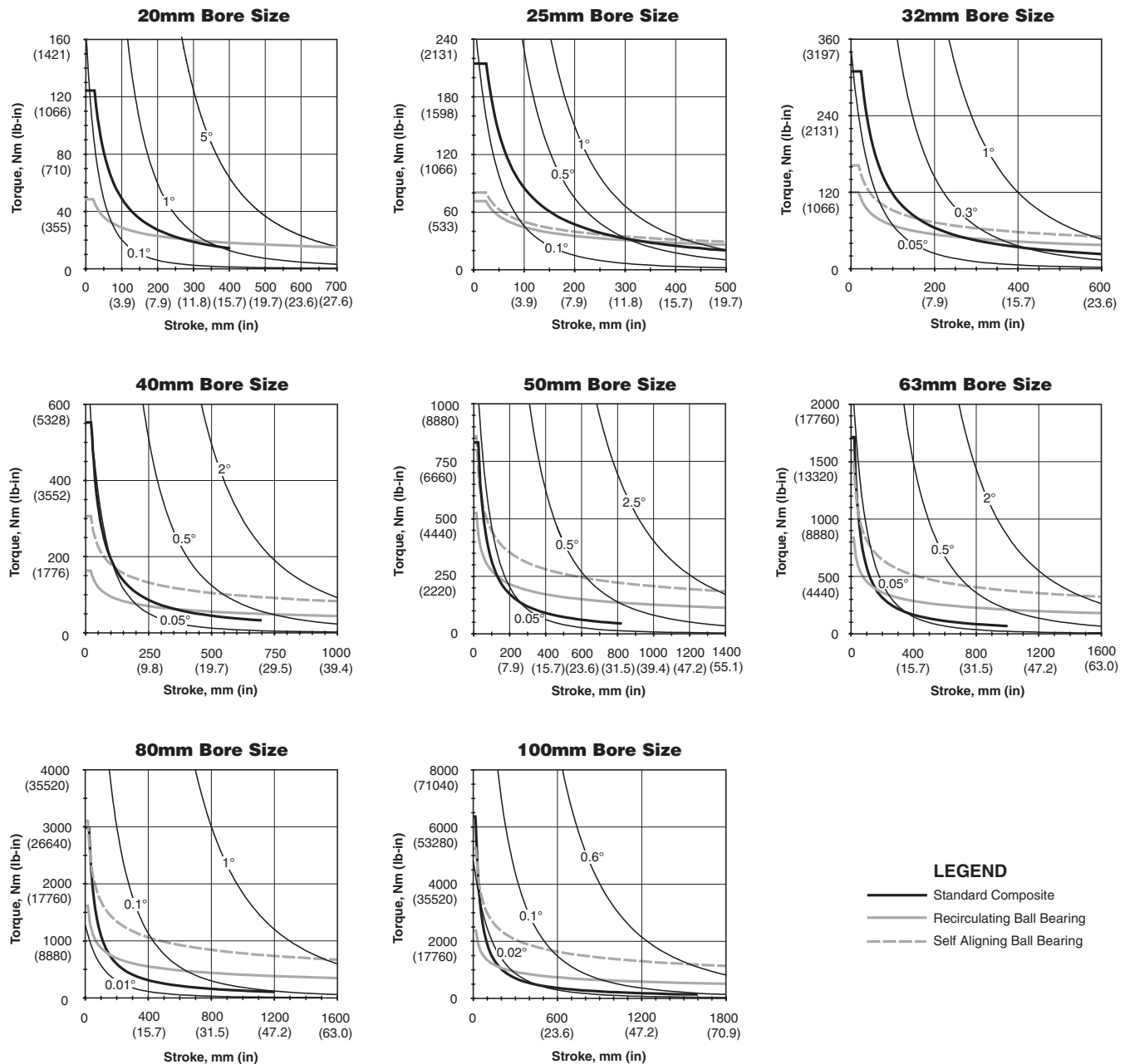
Heavy lines show loading; lighter lines show various degrees of deflection.

**Note:** The following variables commonly affect the bearing life of a guided cylinder:

- Velocity
- Vibration
- Orientation
- Environment (Dust, moisture, etc.)

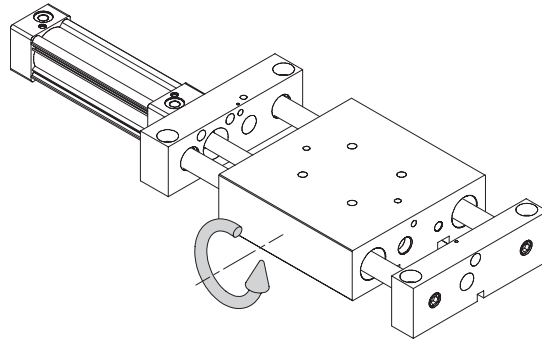
**Standard Shafting**

Guided Cylinders	P5L Series	P5L Series	HB Series	P5E Series	XL Series

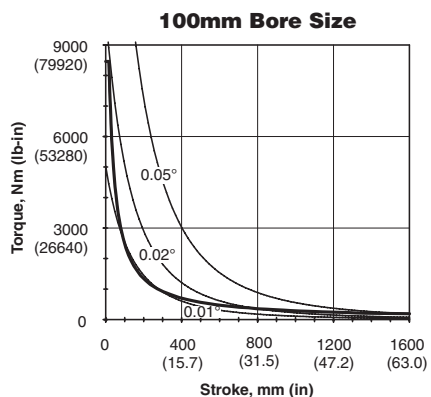
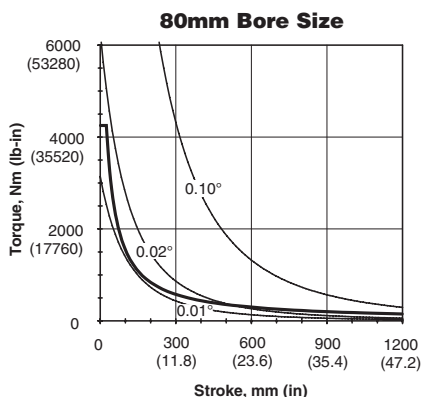
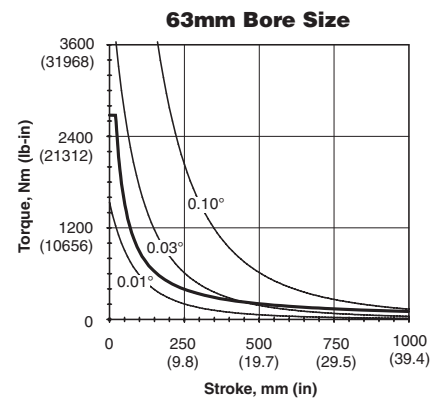
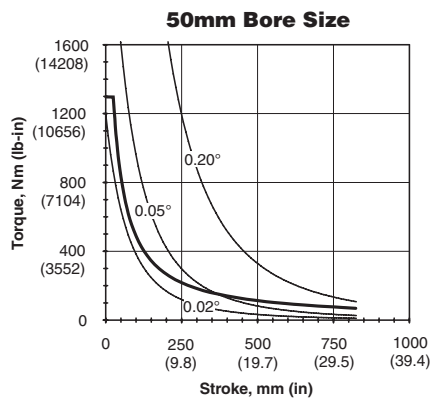
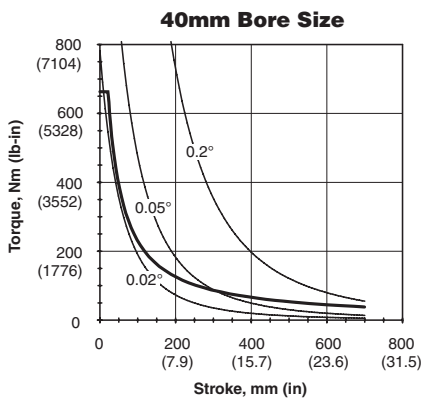
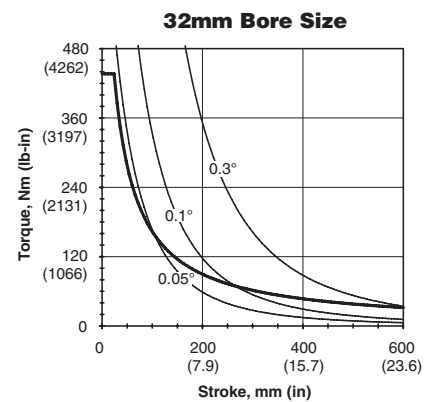
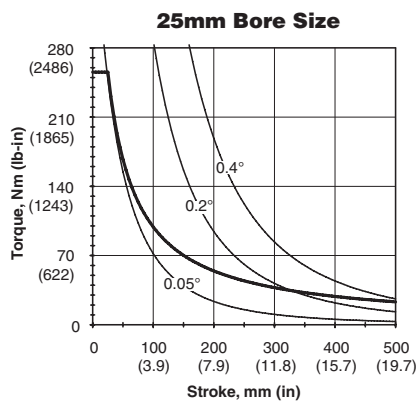
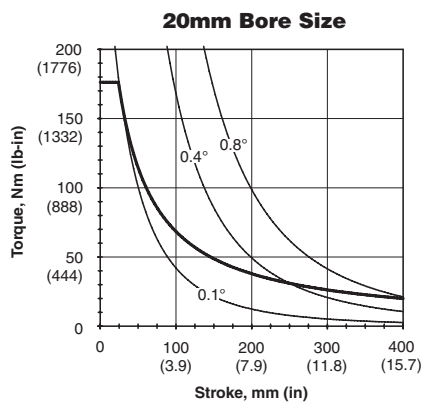


For inventory, lead times, and kit lookup, visit [www.pdnplu.com](http://www.pdnplu.com)

**Symmetrical Pitch Torsional Loading**



**Oversized Shafting**



<b>M</b>	<b>Guided Cylinders</b>
P5T Series	P5L Series
HB Series	P5E Series
XL Series	



For inventory, lead time, and kit lookup, visit [www.pdnplu.com](http://www.pdnplu.com)

**Symmetrical Yaw Torsional Loading**


The graphs on the following two pages illustrate the maximum suggested yaw load at a given actuator stroke. It is assumed that the moment loading is acting about the centerline of the carriage. The graphs include the weight of the carriage and are based on a bearing life of 10 million cycles under a dynamic loading condition. Capacities are based on bearing and shafts only. Mounting bolts/hardware should be investigated per customer application. For an equivalent static load capacity multiply the information in these graphs by 1.5.

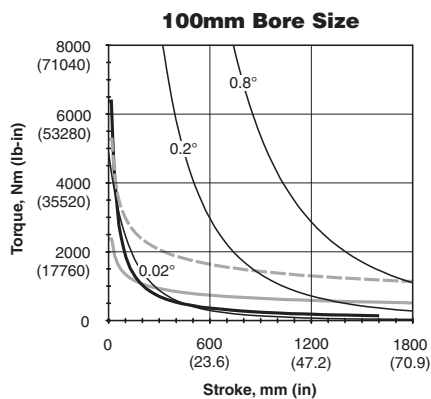
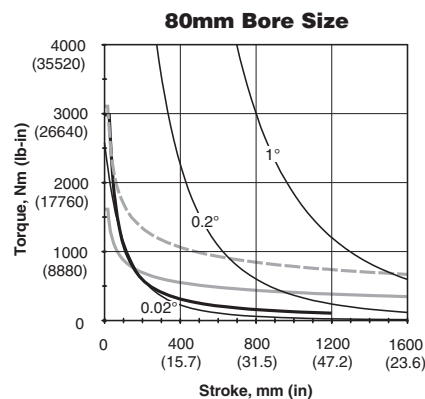
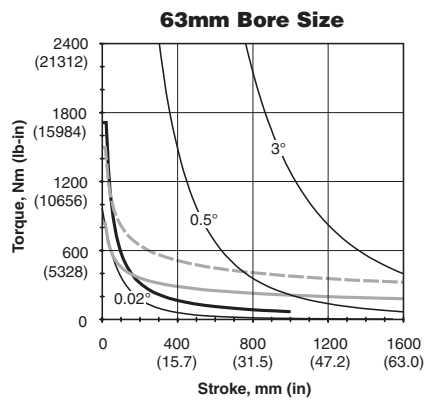
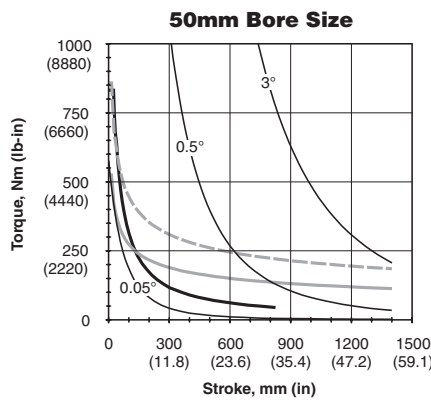
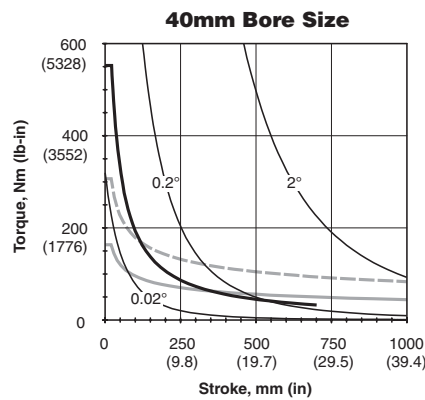
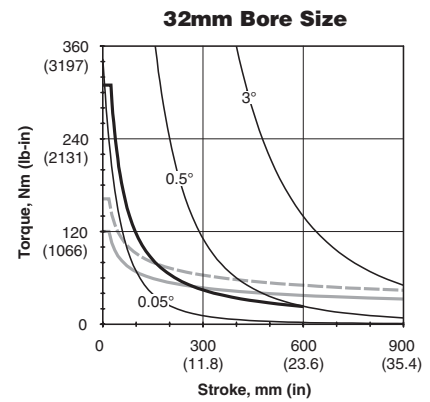
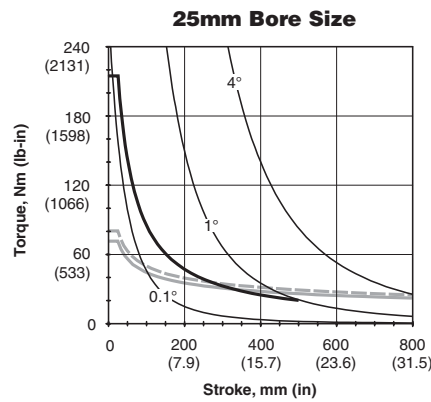
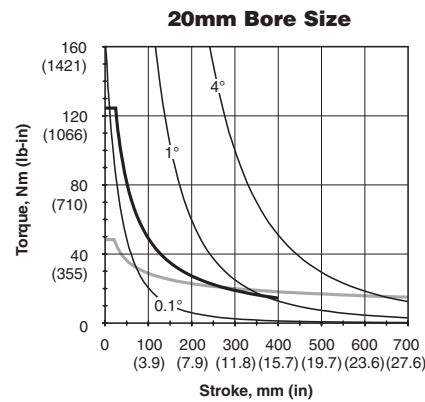
Heavy lines show loading; lighter lines show various degrees of deflection.

**Note:** The following variables commonly affect the bearing life of a guided cylinder:

- Velocity
- Vibration
- Orientation
- Environment (Dust, moisture, etc.)

**Standard Shafting**

 Guided Cylinders	P5T Series
	P5L Series
HB Series	
P5E Series	
XL Series	



**LEGEND**

	Standard Composite
	Recirculating Ball Bearing
	Self Aligning Ball Bearing

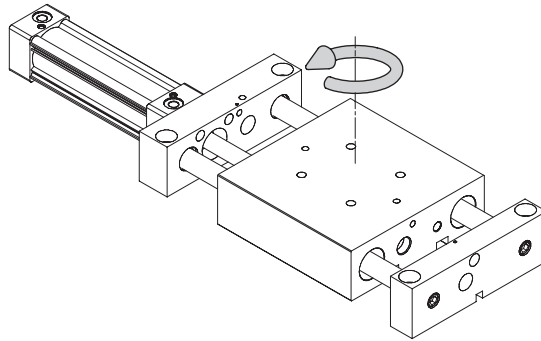


For inventory, lead times, and kit lookup, visit [www.pdnplu.com](http://www.pdnplu.com)

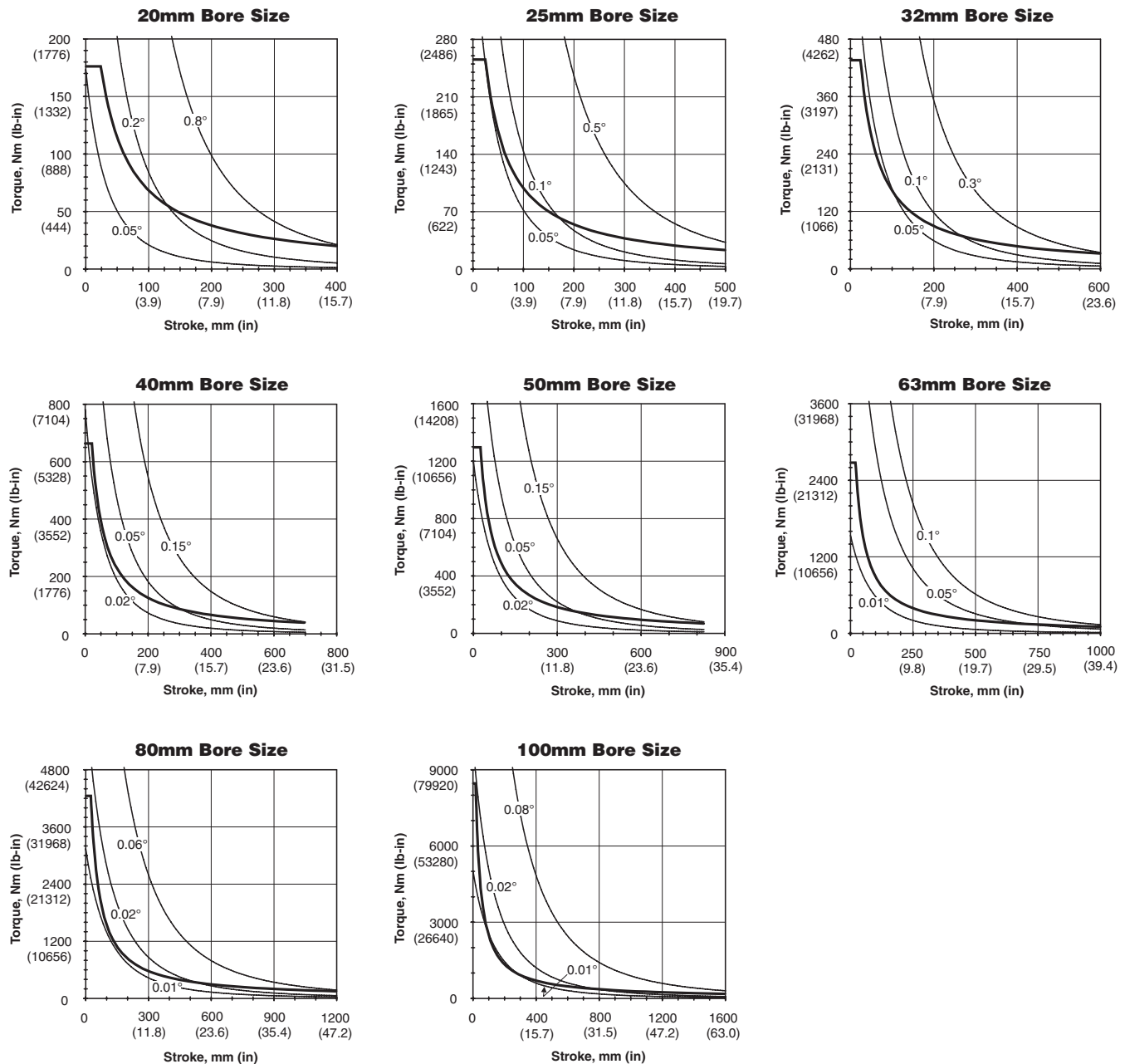
E50

**Parker Hannifin Corporation**  
 Pneumatic Division  
 Richland, Michigan  
[www.parker.com/pneumatics](http://www.parker.com/pneumatics)

**Symmetrical Yaw Torsional Loading**



**Oversized Shafting**



<b>M</b>	Guided Cylinders
	P5T Series
P5L Series	HB Series
P5E Series	XL Series



For inventory, lead time, and kit lookup, visit [www.pdnplu.com](http://www.pdnplu.com)

**Kinetic Energy**

These graphs illustrate the kinetic energy absorption of the P5L series as a weight versus speed chart for both air cushions and shock absorbers.

Moving weight is defined as the weight of the carried load and the weight of any moving parts of the actuator (support rods, tooling plate, etc.). The moving weight from the chart to the right should be considered.

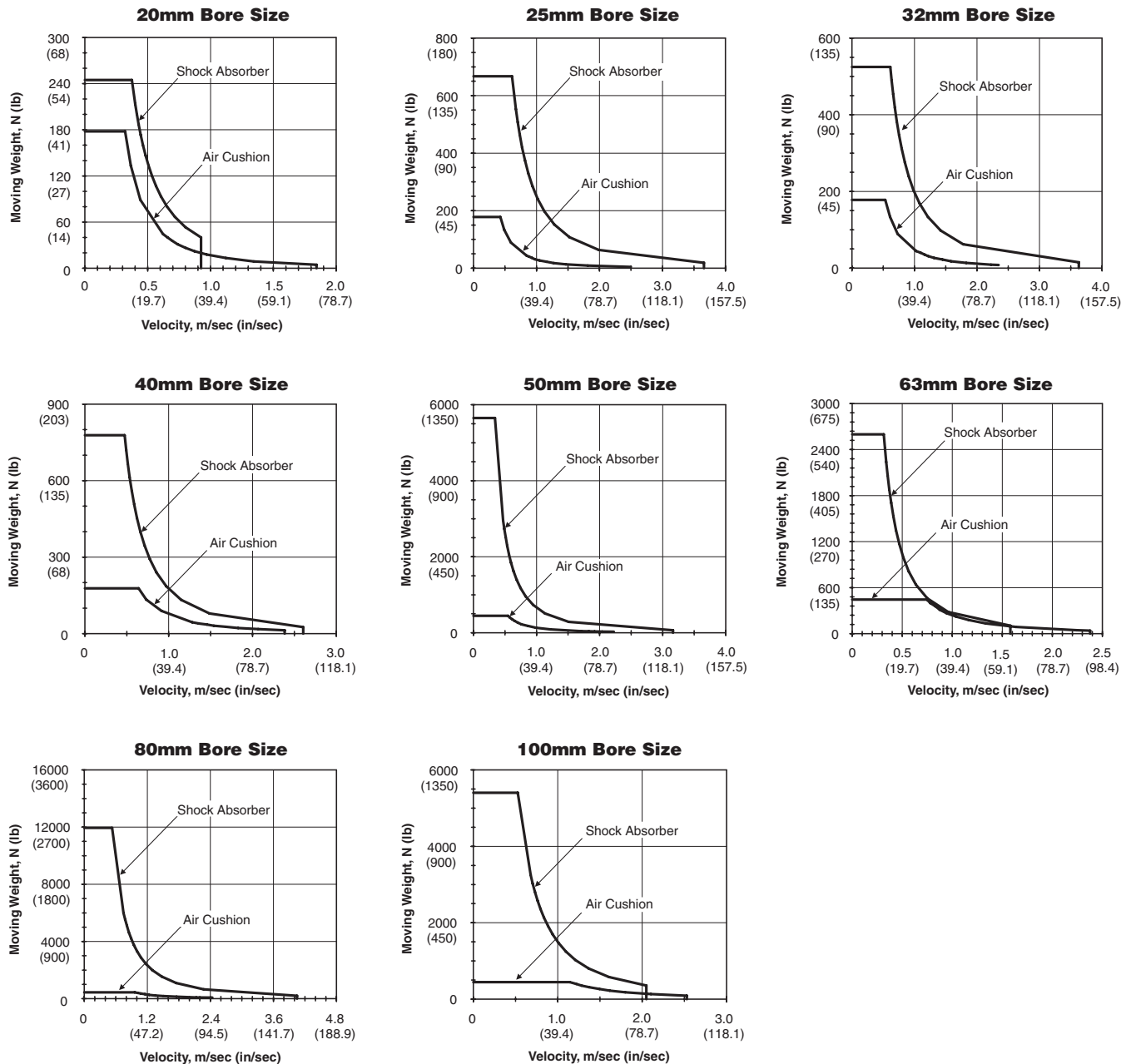
**Note:** These charts are to be used only to determine the energy absorption of each guided cylinder and to determine if shocks or cushions are needed.

Bore	Moving weights (standard shaft)		Moving weights (oversized shaft)	
	kg	lbs	kg	lbs
20	0.60	1.3	0.51	1.1
25	1.17	2.6	1.01	2.2
32	1.77	3.9	1.51	3.3
40	3.10	6.8	2.70	5.9
50	7.10	15.7	6.70	14.8
63	13.4	29.5	10.9	24.0
80	22.5	49.6	19.3	42.6
100	41.9	92.4	33.9	74.6

**Note:** Cylinder moving parts considered negligible.

**P5L Base Slides**

**Guided Cylinders**  
 P5T Series  
 P5L Series  
 HB Series  
 P5E Series  
 XL Series

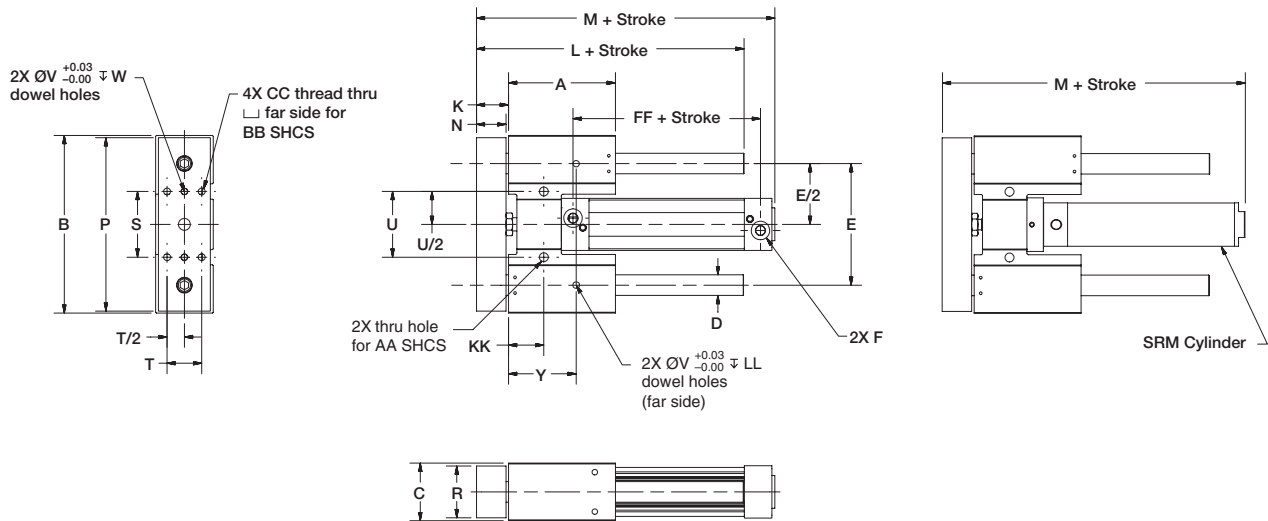


For inventory, lead times, and kit lookup, visit [www.pdnplu.com](http://www.pdnplu.com)



Dimensional Data

Thrust Slides



Dimensions in mm (inch)

Bore size	A	B	C	Ds	Do	E	F (P1D)	F (SRM)	K	L	M (P1D)	M (SRM)	N	P
20	60 (2.4)	98 (3.9)	30 (1.2)	10 (0.4)	12 (0.5)	68 (2.7)	N/A	1/8 NPT	20 (0.8)	86 (3.4)	N/A	112 (4.4)	17 (0.7)	96 (3.8)
25	76 (3.0)	122 (4.8)	38 (1.5)	12 (0.5)	16 (0.6)	84 (3.3)	N/A	1/8 NPT	25 (1.0)	107 (4.2)	N/A	126 (5.0)	22 (0.9)	119 (4.7)
32	84 (3.3)	140 (5.5)	47 (1.9)	16 (0.6)	20 (0.8)	92 (3.6)	G1/8 1/8 NPT	1/8 NPT	27 (1.1)	117 (4.6)	184 (7.2)	124 (4.9)	24 (0.9)	137 (5.4)
40	104 (4.1)	166 (6.5)	56 (2.2)	20 (0.8)	25 (1.0)	116 (4.6)	G1/4 1/4 NPT	1/8 NPT	33 (1.3)	143 (5.6)	192 (7.6)	177 (7.0)	30 (1.2)	161 (6.3)
50	130 (5.1)	216 (8.5)	70 (2.8)	25 (1.0)	30 (1.2)	148 (5.8)	G1/4 1/4 NPT	1/4 NPT	39 (1.5)	175 (6.9)	214 (8.4)	220 (8.7)	36 (1.4)	211 (8.3)
63	152 (6.0)	260 (10.2)	84 (3.3)	30 (1.2)	40 (1.6)	176 (6.9)	G3/8 3/8 NPT	1/4 NPT	43 (1.7)	203 (8.0)	252 (9.9)	237 (9.3)	40 (1.6)	255 (10.0)
80	180 (7.1)	320 (12.6)	102 (4.0)	40 (1.6)	50 (2.0)	220 (8.7)	G3/8 3/8 NPT	3/8 NPT	49 (1.9)	237 (9.3)	270 (10.6)	262 (10.3)	46 (1.8)	315 (12.4)
100	222 (8.7)	390 (15.4)	120 (4.7)	50 (2.0)	60 (2.4)	260 (10.2)	G1/2 1/2 NPT	N/A	59 (2.3)	289 (11.4)	336 (13.2)	N/A	56 (2.2)	383 (15.1)

Bore size	R	S	T	U	V	W	Y	AA	BB	CC	FF (P1D)	KK	LL
20	26 (1.0)	40 (1.6)	16 (0.6)	40 (1.6)	4.03 (0.16)	4 (0.16)	36 (1.4)	M5	M4	M5X0.8	N/A	16 (0.6)	4 (0.16)
25	33 (1.3)	48 (1.9)	20 (0.8)	48 (1.9)	5.03 (0.19)	5 (0.19)	46 (1.8)	M6	M5	M6X1.0	N/A	22 (0.9)	5 (0.19)
32	39 (1.5)	50 (2.0)	24 (0.9)	50 (2.0)	6.03 (0.24)	6 (0.24)	53 (2.1)	M8	M6	M8X1.25	68 (2.7)	28 (1.1)	6 (0.24)
40	51 (2.0)	70 (2.8)	32 (1.3)	70 (2.8)	8.03 (0.32)	8 (0.32)	65 (2.6)	M10	M8	M10X1.5	77 (3.0)	30 (1.2)	8 (0.32)
50	63 (2.5)	80 (3.1)	42 (1.7)	80 (3.1)	8.03 (0.32)	8 (0.32)	83 (3.3)	M10	M8	M10X1.5	78 (3.1)	43 (1.7)	8 (0.32)
63	77 (3.0)	100 (3.9)	52 (2.0)	100 (3.9)	10.03 (0.39)	10 (0.39)	101 (4.0)	M12	M10	M12X1.75	89 (3.5)	51 (2.0)	10 (0.39)
80	95 (3.7)	124 (4.9)	62 (2.4)	124 (4.9)	12.03 (0.47)	12 (0.47)	127 (5.0)	M16	M14	M16X1.5	96 (3.8)	65 (2.6)	12 (0.47)
100	111 (4.4)	148 (5.8)	72 (2.8)	148 (5.8)	12.03 (0.47)	12 (0.47)	154 (6.1)	M20	M16	M20X2.5	102 (4.0)	80 (3.1)	12 (0.47)



Guided  
Cylinders

P5T  
Series

P5L  
Series

HB  
Series

P5E  
Series

XL  
Series

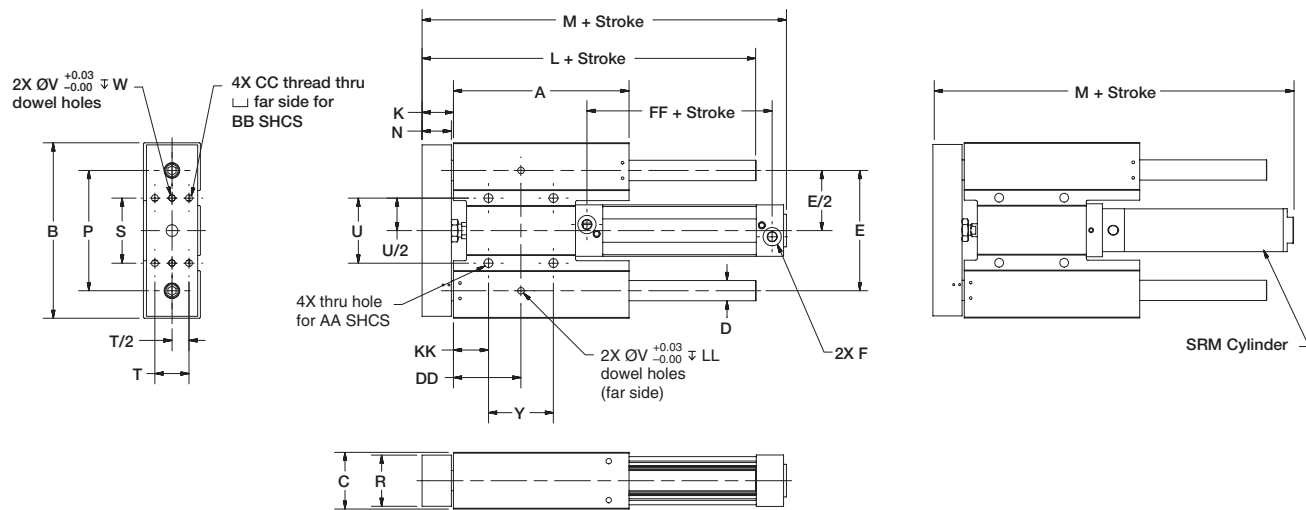


For inventory, lead time, and kit lookup, visit [www.pdnplu.com](http://www.pdnplu.com)

E53

Parker Hannifin Corporation  
Pneumatic Division  
Richland, Michigan  
[www.parker.com/pneumatics](http://www.parker.com/pneumatics)

**Reach Slides**



**Dimensions in mm (inch)**

Bore size	A	B	C	Ds	Do	E	F (P1D)	F (SRM)	K	L	M (P1D)	M (SRM)	N	P
20	98 (3.9)	98 (3.9)	30 (1.2)	10 (0.4)	12 (0.5)	68 (2.7)	N/A	1/8 NPT	20 (0.8)	124 (4.9)	N/A	147 (5.8)	17 (0.7)	96 (3.8)
25	122 (4.8)	122 (4.8)	38 (1.5)	12 (0.5)	16 (0.6)	84 (3.3)	N/A	1/8 NPT	25 (1.0)	153 (6.0)	N/A	172 (6.7)	22 (0.9)	119 (4.7)
32	140 (5.5)	140 (5.5)	47 (1.9)	16 (0.6)	20 (0.8)	92 (3.6)	G1/8 1/8 NPT	1/8 NPT	27 (1.1)	173 (6.8)	238 (9.4)	225 (8.9)	24 (0.9)	137 (5.4)
40	166 (6.5)	166 (6.5)	56 (2.2)	20 (0.8)	25 (1.0)	116 (4.6)	G1/4 1/4 NPT	1/8 NPT	33 (1.3)	205 (8.1)	254 (10.0)	239 (9.4)	30 (1.2)	161 (6.3)
50	216 (8.5)	216 (8.5)	70 (2.8)	25 (1.0)	30 (1.2)	148 (5.8)	G1/4 1/4 NPT	1/4 NPT	39 (1.5)	261 (10.3)	299 (11.8)	306 (12.0)	36 (1.4)	211 (8.3)
63	260 (10.2)	260 (10.2)	84 (3.3)	30 (1.2)	40 (1.6)	176 (6.9)	G3/8 3/8 NPT	1/4 NPT	43 (1.7)	311 (12.2)	360 (14.2)	344 (13.5)	40 (1.6)	255 (10.0)
80	320 (12.6)	320 (12.6)	102 (4.0)	40 (1.6)	50 (2.0)	220 (8.7)	G3/8 3/8 NPT	3/8 NPT	49 (1.9)	377 (14.8)	410 (16.1)	402 (15.8)	46 (1.8)	315 (12.4)
100	390 (15.4)	390 (15.4)	120 (4.7)	50 (2.0)	60 (2.4)	260 (10.2)	G1/2 1/2 NPT	N/A	59 (2.3)	457 (18.0)	505 (19.9)	N/A	56 (2.2)	383 (15.1)

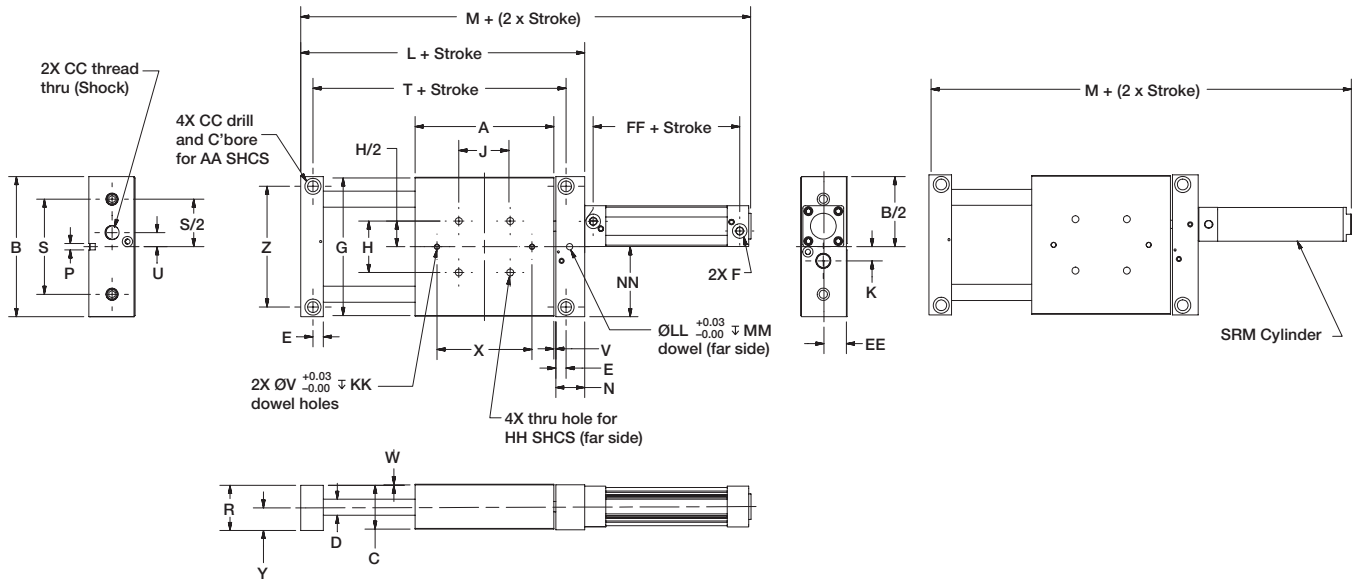
Bore size	R	S	T	U	V	W	Y	AA	BB	CC	DD	FF (P1D)	KK	LL
20	26 (1.0)	40 (1.6)	16 (0.6)	40 (1.6)	4.03 (0.16)	4 (0.16)	40 (1.6)	M5	M4	M5X0.8	36 (1.4)	N/A	16 (0.6)	4 (0.16)
25	33 (1.3)	48 (1.9)	20 (0.8)	48 (1.9)	5.03 (0.19)	5 (0.19)	48 (1.9)	M6	M5	M6X1.0	46 (1.8)	N/A	22 (0.9)	5 (0.19)
32	39 (1.5)	50 (2.0)	24 (0.9)	50 (2.0)	6.03 (0.24)	6 (0.24)	50 (2.0)	M8	M6	M8X1.25	53 (2.1)	68 (2.7)	28 (1.1)	6 (0.24)
40	51 (2.0)	70 (2.8)	32 (1.3)	70 (2.8)	8.03 (0.32)	8 (0.32)	70 (2.8)	M10	M8	M10X1.5	65 (2.6)	77 (3.0)	30 (1.2)	8 (0.32)
50	63 (2.5)	80 (3.1)	42 (1.7)	80 (3.1)	8.03 (0.32)	8 (0.32)	80 (3.1)	M10	M8	M10X1.5	83 (3.3)	78 (3.1)	43 (1.7)	8 (0.32)
63	77 (3.0)	100 (3.9)	52 (2.0)	100 (3.9)	10.03 (0.39)	10 (0.39)	100 (3.9)	M12	M10	M12X1.75	101 (4.0)	89 (3.5)	51 (2.0)	10 (0.39)
80	95 (3.7)	124 (4.9)	62 (2.4)	124 (4.9)	12.03 (0.47)	12 (0.47)	124 (4.9)	M16	M14	M16X1.5	127 (5.0)	96 (3.8)	65 (2.6)	12 (0.47)
100	111 (4.4)	148 (5.8)	72 (2.8)	148 (5.8)	12.03 (0.47)	12 (0.47)	148 (5.8)	M20	M16	M20X2.5	154 (6.1)	102 (4.0)	80 (3.1)	12 (0.47)



For inventory, lead times, and kit lookup, visit [www.pdnplu.com](http://www.pdnplu.com)

Dimensional Data

Base Slides



Dimensions in mm (inch)

Bore size	A	B	C	Ds	Do	E	F (P1D)	F (SRM)	G	H	J	K	L (P1D)	L (SRM)	M (P1D)	M (SRM)	N (P1D)	N (SRM)	P
20	98 (3.9)	100 (3.9)	30 (1.2)	10 (0.4)	12 (0.5)	8 (0.32)	N/A	1/8 NPT	98 (3.9)	40 (1.6)	40 (1.6)	18 (0.7)	N/A	143 (5.6)	N/A	205 (8.1)	N/A	18 (0.7)	5.03 (0.19)
25	122 (4.8)	124 (4.9)	38 (1.5)	12 (0.5)	16 (0.6)	14 (0.55)	N/A	1/8 NPT	122 (4.8)	48 (1.9)	48 (1.9)	22 (0.9)	N/A	181 (7.1)	N/A	252 (9.9)	N/A	24 (0.9)	6.03 (0.24)
32	140 (5.5)	142 (5.6)	45 (1.9)	16 (0.6)	20 (0.8)	12 (0.47)	G1/8 1/8 NPT	1/8 NPT	140 (5.5)	50 (2.0)	50 (2.0)	25 (1.0)	207 (8.1)	200 (7.9)	304 (12.0)	281 (11.1)	35 (1.4)	28 (1.1)	6.03 (0.24)
40	166 (6.5)	168 (6.6)	56 (2.2)	20 (0.8)	25 (1.0)	13 (0.51)	G1/4 1/4 NPT	1/8 NPT	166 (6.5)	70 (2.8)	70 (2.8)	26 (1.0)	238 (9.4)	232 (9.1)	347 (13.6)	311 (12.2)	36 (1.4)	30 (1.2)	10.03 (0.39)
50	216 (8.5)	218 (8.6)	70 (2.8)	25 (1.0)	30 (1.2)	16 (0.63)	G1/4 1/4 NPT	1/4 NPT	216 (8.5)	80 (3.1)	80 (3.1)	22 (0.9)	302 (11.9)	297 (11.7)	412 (16.2)	394 (15.5)	45 (1.8)	40 (1.6)	10.03 (0.39)
63	260 (10.2)	262 (10.3)	84 (3.3)	30 (1.2)	40 (1.6)	19 (0.74)	G3/8 3/8 NPT	1/4 NPT	260 (10.2)	100 (3.9)	100 (3.9)	30 (1.2)	356 (14.0)	306 (12.0)	480 (18.9)	394 (15.5)	47 (1.9)	42 (1.7)	12.03 (0.47)
80	320 (12.6)	322 (12.7)	102 (4.0)	40 (1.6)	50 (2.0)	24 (0.94)	G3/8 3/8 NPT	3/8 NPT	320 (12.6)	124 (4.9)	124 (4.9)	36 (1.4)	437 (17.2)	434 (14.1)	569 (22.4)	533 (21.0)	57 (2.2)	54 (2.1)	16.03 (0.63)
100	390 (15.4)	392 (15.4)	120 (4.7)	50 (2.0)	60 (2.4)	28 (1.10)	G1/2 1/2 NPT	N/A	390 (15.4)	148 (5.8)	148 (5.8)	62 (2.4)	528 (20.8)	N/A	670 (26.4)	N/A	66 (2.6)	N/A	16.03 (0.63)

Bore size	R	S	T	U	V	W	X	Y	Z	AA	CC	EE	FF (P1D)	HH	JJ	KK	LL	MM	NN
20	30 (1.2)	68 (2.7)	120 (4.7)	11 (0.4)	3 (0.1)	1 (0.04)	68 (2.7)	16 (0.63)	86 (3.4)	M6	M12X1.0	15 (0.6)	N/A	M5	4.03 (0.16)	4 (0.16)	5.03 (0.19)	5 (0.19)	50 (1.9)
25	38 (1.5)	84 (3.3)	156 (6.1)	12 (0.5)	3 (0.1)	1 (0.04)	84 (3.3)	20 (0.8)	104 (4.1)	M8	M14X1.5	19 (0.7)	N/A	M6	5.03 (0.19)	5 (0.19)	6.03 (0.24)	6 (0.24)	62 (2.4)
32	48 (1.9)	92 (3.6)	170 (6.7)	11 (0.4)	3 (0.1)	1 (0.04)	92 (3.6)	24 (0.94)	120 (4.7)	M10	M14X1.5	24 (0.9)	68 (2.7)	M8	6.03 (0.24)	6 (0.24)	6.03 (0.24)	6 (0.24)	71 (2.8)
40	56 (2.2)	116 (4.6)	198 (7.8)	20 (0.8)	3 (0.1)	1 (0.04)	116 (4.6)	29 (1.14)	144 (5.7)	M12	M20X1.5	28 (1.1)	77 (3.0)	M10	8.03 (0.32)	8 (0.32)	10.03 (0.39)	10 (0.39)	84 (3.3)
50	70 (2.8)	148 (5.8)	254 (10.0)	22 (0.7)	3 (0.1)	1 (0.04)	148 (5.8)	36 (1.4)	188 (7.4)	M16	M25X1.5	35 (1.4)	78 (3.1)	M10	8.03 (0.32)	8 (0.32)	10.03 (0.39)	10 (0.39)	109 (4.3)
63	84 (3.3)	176 (6.9)	304 (12.0)	30 (1.2)	3 (0.1)	1 (0.04)	176 (6.9)	43 (1.69)	224 (8.8)	M20	M25X1.5	42 (1.7)	89 (3.5)	M12	10.03 (0.39)	10 (0.39)	12.03 (0.47)	12 (0.47)	131 (5.2)
80	102 (4.0)	220 (8.7)	374 (14.7)	36 (1.4)	3 (0.1)	1 (0.04)	220 (8.7)	52 (2.05)	276 (10.9)	M24	M33X1.5	51 (2.0)	96 (3.8)	M16	12.03 (0.47)	12 (0.47)	16.03 (0.63)	16 (0.63)	161 (6.3)
100	120 (4.7)	260 (10.2)	452 (17.8)	36 (1.4)	3 (0.1)	1 (0.04)	260 (10.2)	61 (2.40)	336 (13.2)	M30	M36X1.5	60 (2.4)	102 (4.0)	M20	12.03 (0.47)	12 (0.47)	16.03 (0.63)	16 (0.63)	196 (7.7)



For inventory, lead time, and kit lookup, visit [www.pdnplu.com](http://www.pdnplu.com)

E55

Parker Hannifin Corporation  
Pneumatic Division  
Richland, Michigan  
[www.parker.com/pneumatics](http://www.parker.com/pneumatics)



Guided Cylinders

P5T Series

P5L Series

HB Series

P5E Series

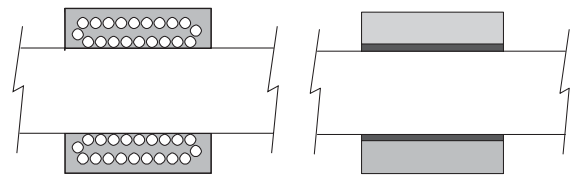
XL Series

Options

**Bushings (J\*, G\*, H\*, S\*)**

Several bushing, bearing and shaft options are available. To assure maximum life from the P5L guidance system, it is critical to match the bearing and shaft type to the application and environment it will be used in.

For bushing load capacities, reference the Engineering Data pages of this section.



Recirculating Ball Bearing

Composite Bushing

Bearing type	Load capacity		Stroke lengths	Wet environment	Wear characteristics
	Short stroke	Long strokes			
Composite	Very Good	Average	Short	Excellent	Good
Recirculating Ball Bearings	Good*	Very Good	Long	Poor	Excellent
Self-Aligning Recirculating Ball Bearings	Good*	Excellent	Longest	Poor	Excellent

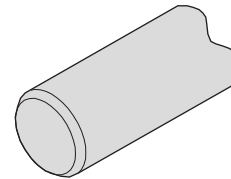
\*It is not recommended to use ball bearings in extremely short strokes subject to rapid cycling

**Note:** Stainless steel shafts should be used in damp or wet environments

**Stainless Steel Shafts**

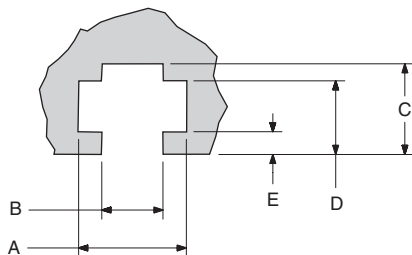
Case hardened, high carbon alloy steel shafting is utilized for standard slides. Stainless steel shafting can be specified for corrosive applications.

**Note:** Carbon steel rods should not be used in any application subject to any amount of moisture.




**T-Slots (-, A)**

Mounting T-slots provide quick and flexible mounting between base, thrust and reach slides. Extruded T-slots are standard on models with bore sizes 20-40mm. Machined T-slots are optional on models with bore sizes from 50-100mm.



Bore	A	B	C	D	E
20	10.0 (0.39)	5.8 (0.23)	9.0 (0.35)	7.0 (0.28)	2.0 (0.08)
25	12.0 (0.47)	6.8 (0.27)	12.0 (0.47)	9.0 (0.35)	3.0 (0.12)
32	15.0 (0.59)	8.8 (0.35)	14.0 (0.55)	11.0 (0.43)	3.5 (0.14)
40	19.0 (0.75)	10.8 (0.43)	15.0 (0.59)	12.0 (0.47)	3.0 (0.12)
50	19.0 (0.75)	10.8 (0.43)	16 (0.63)	13 (0.51)	4.0 (0.16)
63	21 (0.83)	12.8 (0.50)	21.5 (0.85)	18.5 (0.73)	7.5 (0.30)
80	27 (1.06)	16.8 (0.66)	29.5 (1.16)	24.5 (0.96)	9.5 (0.37)
100	33 (1.30)	21 (0.83)	35 (1.38)	30 (1.18)	12.5 (0.49)

Dimensions in mm (in)


 Guided Cylinders  
 P5T Series  
 P5L Series  
 HB Series  
 P5E Series  
 XL Series



For inventory, lead times, and kit lookup, visit [www.pdnplu.com](http://www.pdnplu.com)

Options

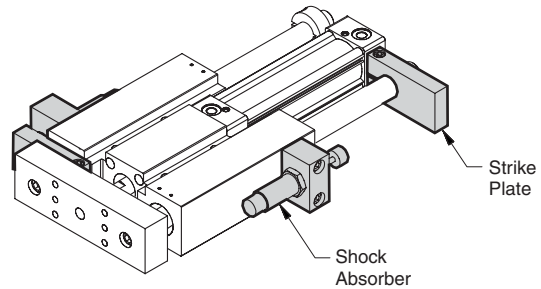
Shock Absorbers

Optional adjustable shock absorbers are available on the P5L series. When specifying this option verify the kinetic energy on pages E40-E41.

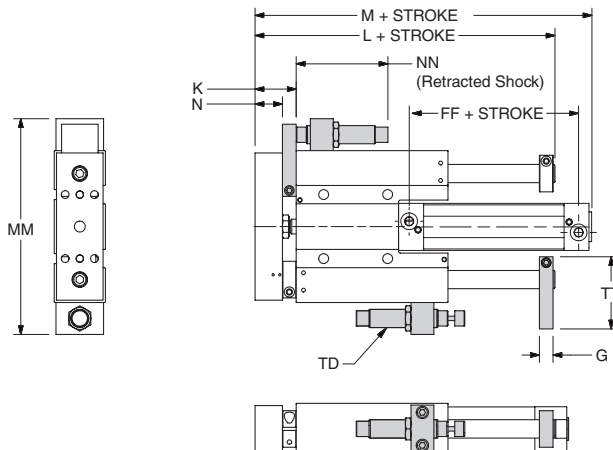
To achieve proper operation it is important to adjust the shock absorber per the application. To properly adjust the shock absorber, cycle the guided cylinder to impact the shock absorber. Rotate the shock adjustment knob, located on the front or the rear of the shock, to achieve a smooth deceleration. Reducing the setting (achieved by rotating the adjustment knob in the counterclockwise direction or towards 9) decreases the resistance. Increasing the setting (achieved by rotating the adjustment in the clockwise direction of towards 0) increases the resistance. A properly adjusted shock absorber will provide smooth deceleration through the stroke of the shock.

The shock absorber option can also be used as a stroke adjuster. To adjust the stroke of the actuator, loosen the socket head cap screw on the striker plate.

**Note:** Using the shock absorber option as a stroke adjuster will only reduce the actuator stroke from a maximum value given in the actuator part number and cannot add additional stroke.



Shock Absorbers - Extend and Retract (AA)



Bore	Thrust						Reach												
	Gs*	Ks*	Go*	Ko*	Ls*	Lo*	M (P1D)	M (SRM)	Ls*	Lo*	M (P1D)	M (SRM)	N	FF (P1D)	MM	NN	TD	TT	
20	9 (0.4)	26 (1.0)	11 (0.4)	28 (1.1)	100 (3.9)	102 (4.0)	N/A	124 (4.9)	138 (5.4)	140 (5.5)	N/A	159 (6.3)	17 (0.7)	N/A	136 (5.4)	74 (2.9)	M12x 1.0	48 (1.9)	
25	11 (0.4)	33 (1.3)	13 (0.5)	35 (1.4)	123 (4.8)	127 (5.0)	N/A	140 (5.5)	169 (6.7)	173 (6.8)	N/A	186 (7.3)	22 (0.9)	N/A	170 (6.7)	80.1 (3.2)	M14x 1.5	57 (2.2)	
32	13 (0.5)	37 (1.5)	15 (0.6)	39 (1.5)	136 (5.4)	140 (5.5)	200 (7.9)	140 (5.5)	192 (7.6)	196 (7.7)	254 (9.9)	241 (9.5)	24 (0.9)	68 (2.7)	188 (7.4)	80.1 (3.2)	M14x 1.5	66 (2.6)	
40	15 (0.6)	45 (1.8)	15 (0.6)	45 (1.8)	166 (6.5)	166 (6.5)	210 (8.3)	195 (7.7)	228 (9.0)	228 (9.0)	272 (10.7)	257 (10.1)	30 (1.2)	77 (3.0)	236 (9.3)	99.5 (3.9)	M20x 1.5	79 (3.1)	
50	15 (0.6)	51 (2.0)	15 (0.6)	51 (2.0)	198 (7.8)	198 (7.8)	232 (9.1)	238 (9.4)	284 (11.2)	284 (11.2)	317 (12.5)	324 (12.8)	36 (1.4)	78 (3.1)	296 (11.7)	117.3 (4.6)	M25x 1.5	98 (3.9)	
63	15 (0.6)	55 (2.2)	15 (0.6)	55 (2.2)	224 (8.8)	224 (8.8)	270 (10.6)	255 (10.0)	332 (13.1)	332 (13.1)	378 (14.9)	362 (14.3)	40 (1.6)	89 (3.5)	340 (13.4)	117.3 (4.6)	M25x 1.5	108 (4.3)	
80	15 (0.6)	61 (2.4)	19 (0.7)	65 (2.6)	258 (10.2)	266 (10.5)	288 (11.3)	280 (11.0)	398 (15.7)	406 (15.6)	428 (16.9)	420 (16.5)	46 (1.8)	96 (3.8)	416 (16.4)	140.5 (5.5)	M33x 1.5	126 (5.0)	
100	19 (0.7)	75 (3.0)	19 (0.7)	75 (3.0)	318 (12.5)	318 (12.5)	358 (14.1)	N/A	486 (19.1)	486 (19.1)	527 (20.7)	N/A	56 (2.2)	102 (4.0)	498 (19.6)	140.5 (5.5)	M36x 1.5	157 (6.2)	

Dimensions in mm (in)

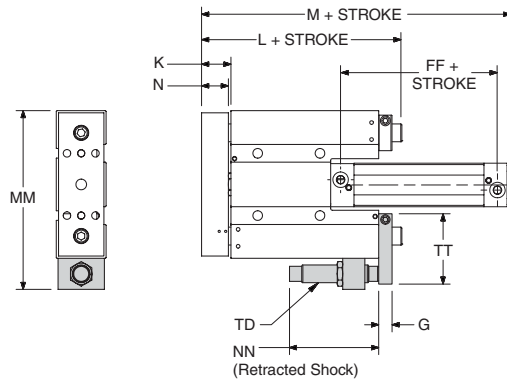
\* s = standard, o = oversized



For inventory, lead time, and kit lookup, visit [www.pdnplu.com](http://www.pdnplu.com)

Options

Shock Absorbers  
Extend Only (AN)

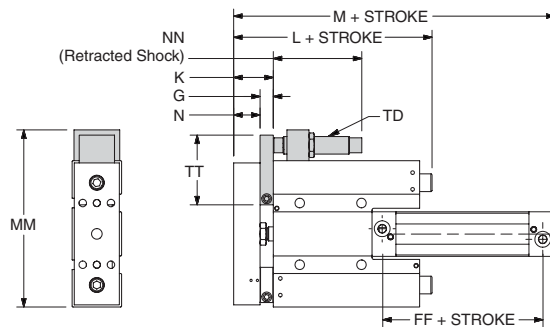


Bore	Thrust						Reach						N	FF (P1D)	MM	NN	TD	TT
	Gs*	Go*	K	Ls*	Lo*	M (P1D)	M (SRM)	Ls*	Lo*	M (P1D)	M (SRM)							
20	9 (0.4)	11 (0.4)	20 (0.8)	100 (3.9)	102 (4.0)	N/A	115 (4.5)	138 (5.4)	140 (5.5)	N/A	150 (5.9)	17 (0.7)	N/A	117 (4.6)	74 (2.9)	M12x 1.0	48 (1.9)	
25	11 (0.4)	13 (0.5)	25 (1.0)	123 (4.8)	127 (5.0)	N/A	129 (5.1)	169 (6.7)	173 (6.8)	N/A	175 (6.9)	22 (0.9)	N/A	146 (5.7)	80.1 (3.2)	M14x 1.5	57 (2.2)	
32	13 (0.5)	15 (0.6)	27 (1.1)	136 (5.4)	140 (5.5)	187 (7.4)	127 (5.0)	192 (7.6)	196 (7.7)	241 (9.5)	228 (8.9)	24 (0.9)	68 (2.7)	164 (6.5)	80.1 (3.2)	M14x 1.5	66 (2.6)	
40	15 (0.6)	15 (0.6)	33 (1.3)	166 (6.5)	166 (6.5)	195 (7.7)	180 (7.1)	228 (9.0)	228 (9.0)	257 (10.1)	242 (9.5)	30 (1.2)	77 (3.0)	201 (7.9)	99.5 (3.9)	M20x 1.5	79 (3.1)	
50	15 (0.6)	15 (0.6)	39 (1.5)	198 (7.8)	198 (7.8)	217 (8.5)	223 (8.8)	284 (11.2)	284 (11.2)	302 (11.9)	309 (12.2)	36 (1.4)	78 (3.1)	256 (10.1)	117.3 (4.6)	M25x 1.5	98 (3.9)	
63	15 (0.6)	15 (0.6)	43 (1.7)	224 (8.8)	224 (8.8)	255 (10.0)	240 (9.4)	332 (13.1)	332 (13.1)	363 (14.3)	347 (13.6)	40 (1.6)	89 (3.5)	300 (11.8)	117.3 (4.6)	M25x 1.5	108 (4.3)	
80	15 (0.6)	19 (0.7)	49 (1.9)	258 (10.2)	266 (10.5)	273 (10.7)	265 (10.4)	398 (15.7)	406 (15.6)	413 (16.3)	405 (15.9)	46 (1.8)	96 (3.8)	368 (14.5)	140.5 (5.5)	M33x 1.5	126 (5.0)	
100	19 (0.7)	19 (0.7)	59 (2.3)	318 (12.5)	318 (12.5)	339 (13.3)	N/A	486 (19.1)	486 (19.1)	508 (20.0)	N/A	56 (2.2)	102 (4.0)	444 (17.5)	140.5 (5.5)	M36x 1.5	157 (6.2)	

Dimensions in mm (in)

\* s = standard, o = oversized

Shock Absorbers  
Retract Only (NA)



Bore	Thrust						Reach						N	FF (P1D)	MM	NN	TD	TT
	Gs*	Ks*	Go*	Ko*	Ls*	Lo*	M (P1D)	M (SRM)	Ls*	Lo*	M (P1D)	M (SRM)						
20	9 (0.4)	26 (1.0)	11 (0.4)	28 (1.1)	100 (3.9)	102 (4.0)	N/A	121 (4.7)	138 (5.4)	140 (5.5)	N/A	156 (6.1)	17 (0.7)	N/A	117 (4.6)	74 (2.9)	M12x 1.0	48 (1.9)
25	11 (0.4)	33 (1.3)	13 (0.5)	35 (1.4)	123 (4.8)	127 (5.0)	N/A	137 (5.4)	169 (6.7)	173 (6.8)	N/A	183 (7.2)	22 (0.9)	N/A	146 (5.7)	80.1 (3.2)	M14x 1.5	57 (2.2)
32	13 (0.5)	37 (1.5)	15 (0.6)	39 (1.5)	136 (5.4)	140 (5.5)	197 (7.7)	137 (5.4)	192 (7.6)	196 (7.7)	251 (9.8)	238 (9.4)	24 (0.9)	68 (2.7)	164 (6.5)	80.1 (3.2)	M14x 1.5	66 (2.6)
40	15 (0.6)	45 (1.8)	15 (0.6)	45 (1.8)	166 (6.5)	166 (6.8)	207 (8.1)	192 (7.5)	228 (9.0)	228 (9.0)	269 (10.6)	254 (10.0)	30 (1.2)	77 (3.0)	201 (7.9)	99.5 (3.9)	M20x 1.5	79 (3.1)
50	15 (0.6)	51 (2.0)	15 (0.6)	51 (2.0)	198 (7.8)	198 (7.8)	229 (9.0)	235 (9.2)	284 (11.2)	284 (11.2)	314 (12.3)	321 (12.6)	36 (1.4)	78 (3.1)	256 (10.1)	117.3 (4.6)	M25x 1.5	98 (3.9)
63	15 (0.6)	55 (2.2)	15 (0.6)	55 (2.2)	224 (8.8)	224 (8.8)	267 (10.5)	252 (9.9)	332 (13.1)	332 (13.1)	375 (14.7)	359 (14.1)	40 (1.6)	89 (3.5)	300 (11.8)	117.3 (4.6)	M25x 1.5	108 (4.3)
80	15 (0.6)	61 (2.4)	19 (0.7)	65 (2.6)	258 (10.2)	266 (10.5)	285 (11.2)	277 (10.9)	398 (15.7)	406 (15.6)	425 (16.7)	417 (16.4)	46 (1.8)	96 (3.8)	368 (14.5)	140.5 (5.5)	M33x 1.5	126 (5.0)
100	19 (0.7)	75 (3.0)	19 (0.7)	75 (3.0)	318 (12.5)	318 (12.5)	355 (13.9)	N/A	486 (19.1)	486 (19.1)	524 (20.6)	N/A	56 (2.2)	102 (4.0)	444 (17.5)	140.5 (5.5)	M36x 1.5	157 (6.2)

Dimensions in mm (in)

\* s = standard, o = oversized

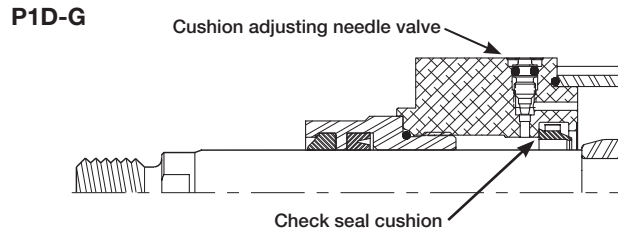
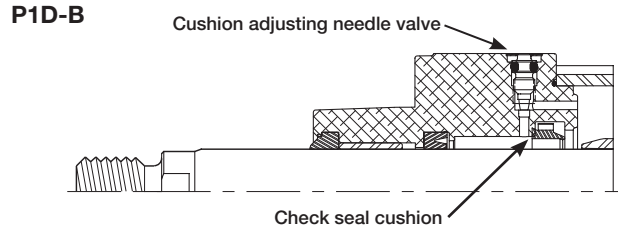
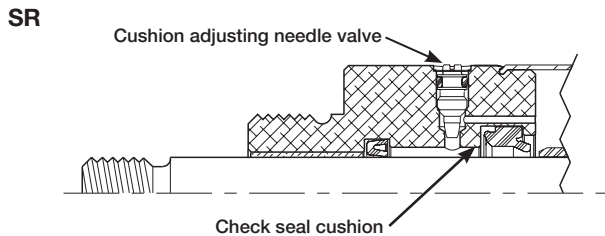


For inventory, lead times, and kit lookup, visit [www.pdnplu.com](http://www.pdnplu.com)

Cylinder Cushions

Fully adjustable cylinder cushions can be provided to reduce speed and energy at the end of cylinder stroke.

**Note:** If stroke adjustment is used in conjunction with cylinder cushions, the cushion effectiveness may be affected.

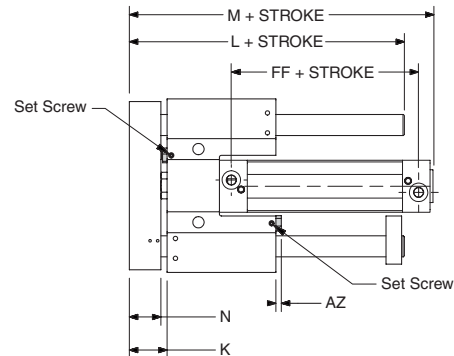
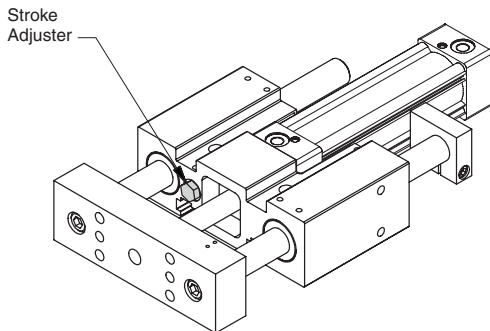


Micro Adjust (EE)

Micro adjusters can be used as an accurate and fine adjustment of end of stroke position. Actual per end stroke adjustment depends on model size. See chart below.

Micro adjusters must be ordered as both ends only. Caution should be used as cushion effectiveness may be affected.

**Note:** Using micro adjusters will only reduce the actuator stroke from a maximum value given in the actuator part number and cannot add additional stroke.



Bore	Thrust				Reach									
	Kmin	Kmax	Ls*	Lo*	M (P1D)	M (SRM)	Ls*	Lo*	M (P1D)	M (SRM)	N	AZmin	AZmax	FF (P1D)
20	23 (0.9)	28 (1.1)	100 (3.9)	102 (4.0)	N/A	121 (4.7)	138 (5.4)	140 (5.5)	N/A	156 (6.1)	17 (0.7)	3.5 (0.1)	8.5 (0.3)	N/A
25	28 (1.1)	37 (1.5)	123 (4.8)	127 (5.0)	N/A	135 (5.3)	169 (6.7)	173 (6.8)	N/A	181 (7.1)	22 (0.9)	3.5 (0.1)	12.5 (0.5)	N/A
32	30 (1.2)	38 (1.5)	136 (5.4)	140 (5.5)	193 (7.6)	133 (5.2)	192 (7.6)	196 (7.7)	247 (9.7)	234 (9.2)	24 (0.9)	4 (0.2)	12 (0.5)	68 (2.7)
40	36 (1.4)	48 (1.9)	166 (6.5)	166 (6.5)	201 (7.9)	186 (7.3)	228 (9.0)	228 (9.0)	263 (10.3)	248 (9.7)	30 (1.2)	5.3 (0.2)	17.3 (0.7)	77 (3.0)
50	42 (1.7)	57 (2.2)	198 (7.8)	198 (7.8)	223 (8.7)	229 (9.0)	284 (11.2)	284 (11.2)	308 (12.1)	315 (12.4)	36 (1.4)	6.4 (0.3)	21.4 (0.8)	78 (3.1)
63	46 (1.8)	63 (2.5)	224 (8.8)	224 (8.8)	261 (10.2)	246 (9.6)	332 (13.1)	332 (13.1)	369 (14.5)	353 (13.9)	40 (1.6)	7.5 (0.3)	24.5 (1.0)	89 (3.5)
80	52 (2.0)	69 (2.7)	258 (10.2)	266 (10.5)	279 (10.9)	271 (10.6)	398 (15.7)	406 (15.6)	419 (16.4)	411 (16.2)	46 (1.8)	7.5 (0.3)	24.5 (1.0)	96 (3.8)
100	62 (2.4)	76 (3.0)	318 (12.5)	318 (12.5)	345 (13.5)	N/A	486 (19.1)	486 (19.1)	514 (20.2)	N/A	56 (2.2)	10 (0.4)	24 (0.9)	102 (4.0)

Dimensions in mm (in)

\* s = standard, o = oversized



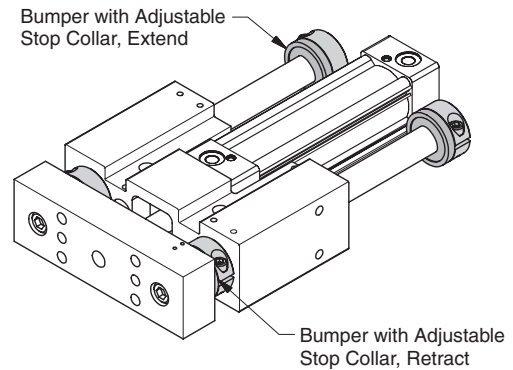
For inventory, lead time, and kit lookup, visit [www.pdnplu.com](http://www.pdnplu.com)

**Bumpers and Adjustable Stop Collars**

Bumpers provide end of stroke noise reduction. Bumpers can be used in conjunction with adjustable stop collars to provide adjustment. When a bumper is specified in the extend stroke a stop collar is provided.

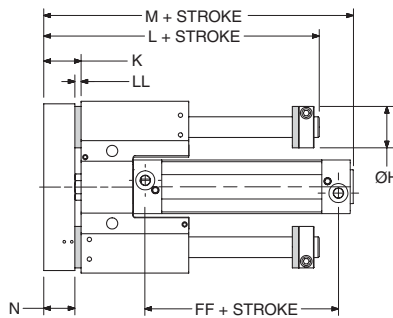
Bumpers provide minimal energy absorption. If high speeds are present consult the kinetic energy section of this catalog to determine if cylinder cushions or shock absorbers are recommended.

A properly adjusted bumper and stop collar will prevent the cylinder from bottoming on the cylinder end cap thus increasing cylinder life.



P5L-T thrust slide shown

**Bumpers Both Ends (KB)**



Bore	Thrust					Reach									
	Hs*	Ho*	K	Ls*	Lo*	M (P1D)	M (SRM)	Ls*	Lo*	M (P1D)	M (SRM)	N	FF (P1D)	LL	
20	24 (0.9)	28 (1.1)	23 (0.9)	100 (3.9)	102 (4.0)	N/A	121 (4.7)	138 (5.4)	140 (5.5)	N/A	156 (6.1)	17 (0.7)	N/A	6 (0.2)	
25	28 (1.1)	34 (1.3)	28 (1.1)	123 (4.8)	127 (5.0)	N/A	135 (5.3)	169 (6.6)	173 (6.8)	N/A	181 (7.1)	22 (0.9)	N/A	6 (0.2)	
32	34 (1.3)	40 (1.6)	30 (1.2)	136 (5.4)	140 (5.5)	193 (7.6)	133 (5.2)	192 (7.6)	248 (9.8)	247 (9.7)	234 (9.2)	24 (0.9)	68 (2.7)	6 (0.2)	
40	40 (1.6)	45 (1.8)	36 (1.4)	166 (6.5)	166 (6.5)	201 (7.9)	186 (7.3)	228 (9.0)	290 (11.4)	263 (10.3)	248 (9.7)	30 (1.2)	77 (3.0)	6 (0.2)	
50	45 (1.8)	54 (2.1)	42 (1.7)	198 (7.8)	198 (7.8)	223 (8.7)	229 (9.0)	284 (11.2)	370 (14.6)	308 (12.1)	315 (12.4)	36 (1.4)	78 (3.1)	6 (0.2)	
63	54 (2.1)	60 (2.4)	46 (1.8)	224 (8.8)	224 (8.8)	261 (10.2)	246 (9.6)	332 (13.1)	440 (17.3)	369 (14.5)	353 (13.9)	40 (1.6)	89 (3.5)	6 (0.2)	
80	60 (2.4)	78 (3.1)	52 (2.0)	258 (10.1)	266 (10.5)	279 (10.9)	271 (10.6)	398 (15.7)	538 (21.2)	419 (16.4)	411 (16.2)	46 (1.8)	96 (3.8)	6 (0.2)	
100	78 (3.1)	88 (3.5)	62 (2.4)	318 (12.5)	318 (12.5)	345 (13.5)	N/A	486 (19.1)	654 (25.7)	514 (20.2)	N/A	56 (2.2)	102 (4.0)	6 (0.2)	

Dimensions in mm (in) \* s = standard, o = oversized

**P**  
 Guided Cylinders  
 P5T Series  
 P5L Series  
 HB Series  
 P5E Series  
 XL Series

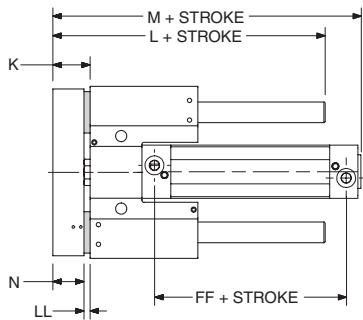


For inventory, lead times, and kit lookup, visit [www.pdnplu.com](http://www.pdnplu.com)



Options

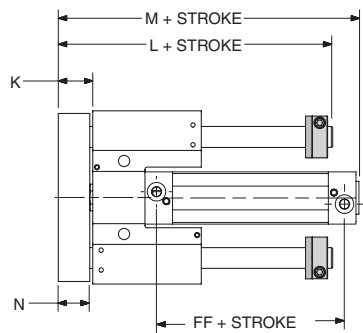
Bumpers on Retract Only (NB)



Bore	K	Thrust				Reach				N	FF (P1D)	LL
		Ls*	Lo*	M (P1D)	M (SRM)	Ls*	Lo*	M (P1D)	M (SRM)			
20	23 (0.9)	100 (3.9)	102 (4.0)	N/A	118 (4.6)	138 (5.4)	140 (5.5)	N/A	153 (6.0)	17 (0.7)	N/A	6 (0.2)
25	28 (1.1)	123 (4.8)	127 (5.0)	N/A	132 (5.2)	169 (6.7)	173 (6.8)	N/A	178 (7.0)	22 (0.9)	N/A	6 (0.2)
32	30 (1.2)	136 (5.4)	140 (5.5)	190 (7.5)	130 (5.1)	192 (7.6)	196 (7.7)	244 (9.6)	231 (9.1)	24 (0.9)	68 (2.7)	6 (0.2)
40	36 (1.4)	166 (6.5)	166 (6.5)	198 (7.8)	183 (7.2)	228 (9.0)	228 (9.0)	260 (10.2)	245 (9.6)	30 (1.2)	77 (3.0)	6 (0.2)
50	42 (1.7)	198 (7.8)	198 (7.8)	220 (8.6)	226 (8.9)	284 (11.2)	284 (11.2)	305 (12.0)	312 (12.3)	36 (1.4)	78 (3.1)	6 (0.2)
63	46 (1.8)	224 (8.8)	224 (8.8)	258 (10.1)	243 (9.5)	332 (13.1)	332 (13.1)	366 (14.4)	350 (13.7)	40 (1.6)	89 (3.5)	6 (0.2)
80	52 (2.0)	258 (10.2)	266 (10.5)	276 (10.8)	268 (10.5)	398 (15.7)	406 (16.0)	416 (16.4)	408 (16.1)	46 (1.8)	96 (3.8)	6 (0.2)
100	62 (2.4)	318 (12.5)	318 (12.5)	342 (13.4)	N/A	486 (19.1)	486 (19.1)	511 (20.1)	N/A	56 (2.2)	102 (4.0)	6 (0.2)

Dimensions in mm (in) \* s = standard, o = oversized

Bumpers and Adjustable Stop Collars, Extend Only (KN)



Bore	K	Thrust				Reach				N	FF (P1D)
		Ls*	Lo*	M (P1D)	M (SRM)	Lo*	Ls*	M (P1D)	M (SRM)		
20	20 (0.8)	109 (4.3)	111 (4.4)	N/A	115 (4.5)	147 (5.8)	149 (5.9)	N/A	150 (5.9)	17 (0.7)	N/A
25	25 (1.0)	134 (5.3)	138 (5.4)	N/A	129 (5.1)	180 (7.1)	184 (7.2)	N/A	175 (6.9)	22 (0.9)	N/A
32	27 (1.1)	148 (5.8)	152 (6.0)	187 (7.3)	127 (5.0)	204 (8.0)	208 (8.2)	241 (9.5)	228 (8.9)	24 (0.9)	68 (2.7)
40	33 (1.3)	178 (7.0)	178 (7.0)	195 (7.6)	180 (7.1)	240 (9.4)	240 (9.4)	257 (10.1)	242 (9.5)	30 (1.2)	77 (3.0)
50	39 (1.5)	210 (8.3)	210 (8.3)	217 (8.5)	223 (8.8)	296 (11.7)	296 (11.7)	302 (11.9)	309 (12.2)	36 (1.4)	78 (3.1)
63	43 (1.7)	236 (9.3)	236 (9.3)	255 (10.0)	240 (9.4)	344 (13.5)	344 (13.5)	363 (14.3)	347 (13.6)	40 (1.6)	89 (3.5)
80	49 (1.9)	271 (10.7)	279 (11.0)	273 (10.7)	265 (10.4)	411 (16.2)	419 (16.5)	413 (16.3)	405 (15.9)	46 (1.8)	96 (3.8)
100	59 (2.3)	330 (13.0)	330 (13.0)	339 (13.3)	N/A	498 (19.6)	498 (19.6)	508 (20.2)	N/A	56 (2.2)	102 (4.0)

Dimensions in mm (in) \* s = standard, o = oversized

Guided Cylinders

P5T Series

P5L Series

HB Series

P5E Series

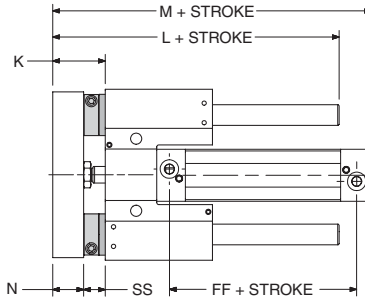
XL Series



For inventory, lead time, and kit lookup, visit [www.pdnplu.com](http://www.pdnplu.com)

Options

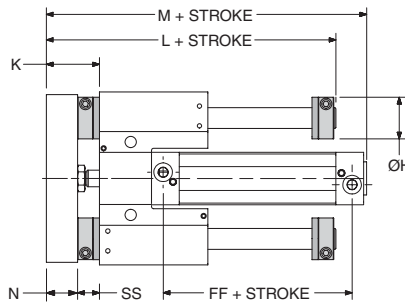
Bumpers and Adjustable Stop Collars, Retract Only (NK)



Dimensions in mm (in)  
\* s = standard, o = oversized

Bore	Thrust				Reach								N	FF (P1D)	SSs*	SSo*		
	Ks	Ko	Ls*	Lo*	Ms* (P1D)	Mo* (P1D)	Ms* (SRM)	Mo* (SRM)	Ls*	Lo*	Ms* (P1D)	Mo* (P1D)					Ms* (SRM)	Mo* (SRM)
20	32 (1.3)	34 (1.3)	109 (4.3)	111 (4.4)	N/A	N/A	127 (5.0)	129 (5.1)	147 (5.8)	149 (5.9)	N/A	N/A	150 (5.9)	150 (5.9)	17 (0.7)	N/A	15 (0.6)	17 (0.7)
25	39 (1.5)	41 (1.6)	134 (5.3)	138 (5.4)	N/A	N/A	143 (5.6)	145 (5.7)	180 (7.1)	184 (7.2)	N/A	N/A	175 (6.9)	175 (6.9)	22 (0.9)	N/A	17 (0.7)	19 (0.7)
32	43 (1.7)	45 (1.8)	148 (5.8)	152 (6.0)	203 (8.0)	205 (8.1)	143 (5.6)	145 (5.7)	204 (8.0)	208 (8.2)	241 (9.5)	241 (9.5)	228 (8.9)	228 (8.9)	24 (0.9)	68 (2.7)	19 (0.7)	21 (0.8)
40	51 (2.0)	51 (2.0)	178 (7.0)	178 (7.0)	213 (8.4)	213 (8.4)	198 (7.8)	198 (7.8)	240 (9.4)	240 (9.4)	257 (10.1)	257 (10.1)	242 (9.5)	242 (9.5)	30 (1.2)	77 (3.0)	21 (0.8)	21 (0.8)
50	57 (2.2)	57 (2.2)	210 (8.3)	210 (8.3)	235 (9.3)	235 (9.3)	241 (9.5)	241 (9.5)	296 (11.7)	296 (11.7)	302 (11.9)	302 (11.9)	309 (12.2)	309 (12.2)	36 (1.4)	78 (3.1)	21 (0.8)	21 (0.8)
63	61 (2.4)	61 (2.4)	236 (9.3)	236 (9.3)	273 (10.7)	273 (10.7)	258 (10.1)	258 (10.1)	344 (13.5)	344 (13.5)	363 (14.3)	363 (14.3)	347 (13.6)	347 (13.6)	40 (1.6)	89 (3.5)	21 (0.8)	21 (0.8)
80	67 (2.6)	71 (2.8)	271 (10.7)	279 (11.0)	291 (11.5)	291 (11.5)	283 (11.1)	283 (11.1)	411 (16.2)	419 (16.5)	413 (16.3)	413 (16.3)	405 (15.9)	405 (15.9)	46 (1.8)	96 (3.8)	21 (0.8)	25 (1.0)
100	81 (3.2)	81 (3.2)	330 (13.0)	330 (13.0)	361 (14.2)	361 (14.2)	N/A	N/A	492 (19.4)	492 (19.4)	508 (20.2)	508 (20.2)	N/A	N/A	56 (2.2)	102 (4.0)	25 (1.0)	25 (1.0)

Bumpers and Adjustable Stop Collars, Both Ends (KK)



Dimensions in mm (in)  
\* s = standard, o = oversized

Bore	Thrust				Reach								N	FF (P1D)	SSs*	SSo*				
	Hs*	Ho*	Ks*	Ko*	Ls*	Lo*	Ms* (P1D)	Mo* (P1D)	Ms* (SRM)	Mo* (SRM)	Ls*	Lo*					Ms* (P1D)	Mo* (P1D)	Ms* (SRM)	Mo* (SRM)
20	24 (0.9)	28 (1.1)	32 (1.3)	34 (1.3)	109 (4.3)	111 (4.4)	N/A	N/A	130 (5.1)	132 (5.2)	147 (5.8)	149 (5.9)	N/A	N/A	162 (6.4)	164 (6.5)	17 (0.7)	N/A	15 (0.6)	17 (0.7)
25	28 (1.1)	34 (1.3)	39 (1.5)	41 (1.6)	134 (5.3)	138 (5.4)	N/A	N/A	146 (5.7)	148 (5.8)	180 (7.1)	184 (7.2)	N/A	N/A	189 (7.4)	191 (7.5)	22 (0.9)	N/A	17 (0.7)	19 (0.7)
32	34 (1.3)	40 (1.6)	43 (1.7)	45 (1.8)	148 (5.8)	152 (6.0)	206 (8.1)	208 (8.2)	146 (5.7)	148 (5.8)	204 (8.0)	208 (8.2)	257 (10.1)	259 (10.2)	244 (9.6)	246 (9.7)	24 (0.9)	68 (2.7)	19 (0.7)	21 (0.8)
40	40 (1.6)	45 (1.8)	51 (2.0)	51 (2.0)	178 (7.0)	178 (7.0)	216 (8.5)	216 (8.5)	201 (7.9)	201 (7.9)	240 (9.4)	240 (9.4)	275 (10.8)	275 (10.8)	260 (10.2)	260 (10.2)	30 (1.2)	77 (3.0)	21 (0.8)	21 (0.8)
50	45 (1.8)	54 (2.1)	57 (2.2)	57 (2.2)	210 (8.3)	210 (8.3)	238 (9.4)	238 (9.4)	244 (9.6)	244 (9.6)	296 (11.7)	296 (11.7)	320 (12.6)	320 (12.6)	327 (12.9)	327 (12.9)	36 (1.4)	78 (3.1)	21 (0.8)	21 (0.8)
63	54 (2.1)	60 (2.4)	61 (2.4)	61 (2.4)	236 (9.3)	236 (9.3)	276 (10.8)	276 (10.8)	261 (10.3)	261 (10.3)	344 (13.5)	344 (13.5)	381 (15.0)	381 (15.0)	365 (14.4)	365 (14.4)	40 (1.6)	89 (3.5)	21 (0.8)	21 (0.8)
80	60 (2.4)	78 (3.1)	67 (2.6)	71 (2.8)	271 (10.7)	279 (11.0)	294 (11.6)	298 (11.7)	286 (11.2)	290 (11.4)	411 (16.2)	419 (16.5)	431 (16.9)	435 (17.1)	423 (16.6)	427 (16.8)	46 (1.8)	96 (3.8)	21 (0.8)	25 (1.0)
100	78 (3.1)	88 (3.5)	81 (3.2)	71 (2.8)	330 (13.0)	330 (13.0)	364 (14.3)	364 (14.3)	N/A	N/A	498 (19.6)	498 (19.6)	530 (20.8)	530 (20.8)	N/A	N/A	56 (2.2)	102 (4.0)	25 (1.0)	25 (1.0)



For inventory, lead times, and kit lookup, visit [www.pdnplu.com](http://www.pdnplu.com)

E62

Parker Hannifin Corporation  
Pneumatic Division  
Richland, Michigan  
[www.parker.com/pneumatics](http://www.parker.com/pneumatics)

Options

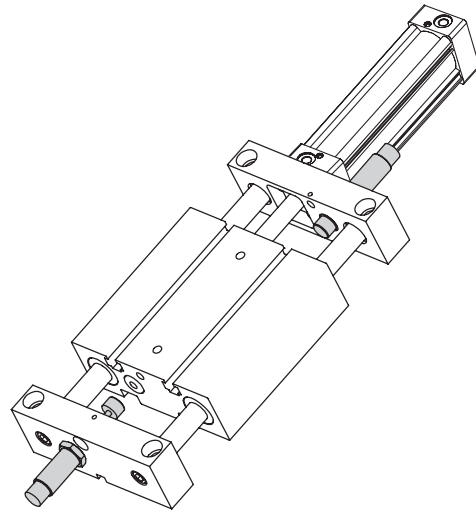
Shock Absorbers

Optional adjustable shock absorbers are available on the P5L series. When specifying this option verify the kinetic energy on page E52.

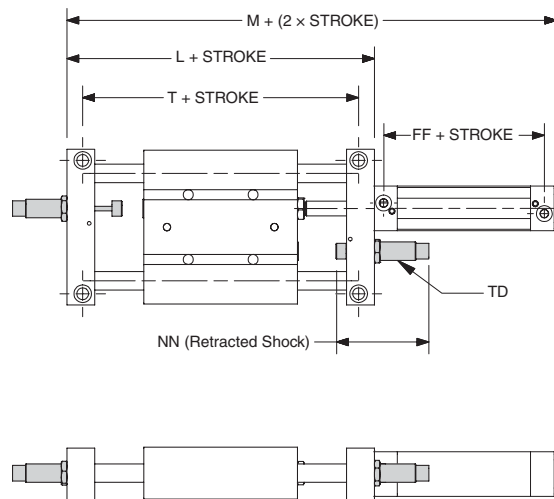
To achieve proper operation it is important to adjust the shock absorber per the application. To properly adjust the shock absorber, cycle the guided cylinder to impact the shock absorber. Rotate the shock adjustment knob, located on the front or the rear of the shock, to achieve a smooth deceleration. Reducing the setting (achieved by rotating the adjustment knob in the counterclockwise direction or towards 9) decreases the resistance. Increasing the setting (achieved by rotating the adjustment in the clockwise direction or towards 0) increases the resistance. A properly adjusted shock absorber will provide smooth deceleration through the stroke of the shock.

The shock absorber option can also be used as a stroke adjuster. To adjust the stroke of the actuator, loosen the jam nut and thread shock in/out.

**Note:** Using the shock absorber option as a stroke adjuster will only reduce the actuator stroke from a maximum value given in the actuator part number and cannot add additional stroke.



Shock Absorbers Both Ends (AA)



Bore	L (P1D)	L (SRM)	M (P1D)	M (SRM)	T	FF (P1D)	NN	TD
20	N/A	143 (5.6)	N/A	205 (8.1)	120 (4.7)	N/A	74 (2.9)	M12X1.0
25	N/A	181 (7.1)	N/A	252 (9.9)	156 (6.1)	N/A	80.1 (3.2)	M14X1.5
32	207 (8.1)	200 (7.9)	304 (11.9)	281 (11.0)	170 (6.7)	68 (2.7)	80.1 (3.2)	M14X1.5
40	238 (9.4)	232 (9.1)	347 (13.6)	311 (12.2)	198 (7.8)	77 (3.0)	99.5 (3.9)	M20X1.5
50	302 (11.9)	297 (11.7)	412 (16.2)	394 (15.5)	254 (10.0)	78 (3.1)	117.3 (4.6)	M25X1.5
63	356 (14.0)	306 (12.0)	480 (18.9)	394 (15.5)	304 (12.0)	89 (3.5)	117.3 (4.6)	M25X1.5
80	437 (17.2)	434 (17.0)	569 (22.4)	533 (20.9)	374 (14.7)	96 (3.8)	140.5 (5.5)	M33X1.5
100	528 (20.8)	N/A	670 (26.4)	N/A	452 (17.8)	102 (4.0)	140.5 (5.5)	M36X1.5

Dimensions in mm (in)

Guided Cylinders

P5T Series

P5L Series

HB Series

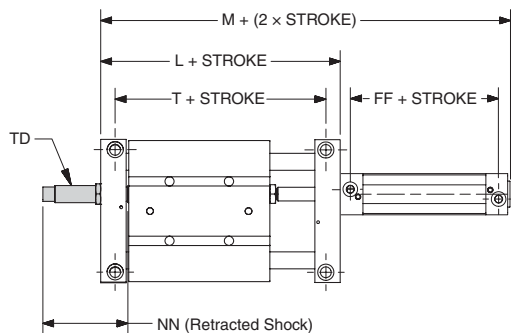
P5E Series

XL Series



For inventory, lead time, and kit lookup, visit [www.pdnplu.com](http://www.pdnplu.com)

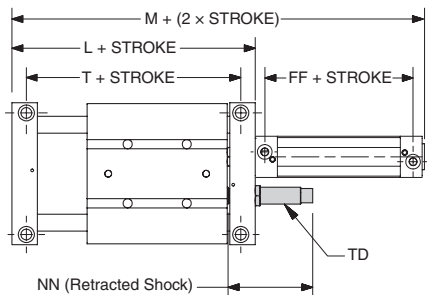
Shock Absorber Extend Only (AN)



Bore	L (P1D)	L (SRM)	M (P1D)	M (SRM)	T	FF (P1D)	NN	TD
20	N/A	143 (5.6)	N/A	205 (8.1)	120 (4.7)	N/A	74 (2.9)	M12x1.0
25	N/A	181 (7.1)	N/A	252 (9.9)	156 (6.1)	N/A	80.1 (3.2)	M14x1.5
32	207 (8.1)	200 (7.9)	304 (11.9)	281 (11.0)	170 (6.7)	68 (2.7)	80.1 (3.2)	M14x1.5
40	238 (9.4)	232 (9.1)	347 (13.6)	311 (12.2)	198 (7.8)	77 (3.0)	99.5 (3.9)	M20x1.5
50	302 (11.9)	297 (11.7)	412 (16.2)	394 (15.5)	254 (10.0)	78 (3.1)	117.3 (4.6)	M25x1.5
63	356 (14.0)	306 (12.0)	480 (18.9)	394 (15.5)	304 (12.0)	89 (3.5)	117.3 (4.6)	M25x1.5
80	437 (17.2)	434 (17.0)	569 (22.4)	533 (20.9)	374 (14.7)	96 (3.8)	140.5 (5.5)	M33x1.5
100	528 (20.8)	N/A	670 (26.4)	N/A	452 (17.8)	102 (4.0)	140.5 (5.5)	M36x1.5


Dimensions in mm (in)

Shock Absorber Retract Only (NA)



Bore	L (P1D)	L (SRM)	M (P1D)	M (SRM)	T	FF (P1D)	NN	TD
20	N/A	143 (5.6)	N/A	205 (8.1)	120 (4.7)	N/A	74 (2.9)	M12x1.0
25	N/A	181 (7.1)	N/A	252 (9.9)	156 (6.1)	N/A	80.1 (3.2)	M14x1.5
32	207 (8.1)	200 (7.9)	304 (11.9)	281 (11.0)	170 (6.7)	68 (2.7)	80.1 (3.2)	M14x1.5
40	238 (9.4)	232 (9.1)	347 (13.6)	311 (12.2)	198 (7.8)	77 (3.0)	99.5 (3.9)	M20x1.5
50	302 (11.9)	297 (11.7)	412 (16.2)	394 (15.5)	254 (10.0)	78 (3.1)	117.3 (4.6)	M25x1.5
63	356 (14.0)	306 (12.0)	480 (18.9)	394 (15.5)	304 (12.0)	89 (3.5)	117.3 (4.6)	M25x1.5
80	437 (17.2)	434 (17.0)	569 (22.4)	533 (20.9)	374 (14.7)	96 (3.8)	140.5 (5.5)	M33x1.5
100	528 (20.8)	N/A	670 (26.4)	N/A	452 (17.8)	102 (4.0)	140.5 (5.5)	M36x1.5

Dimensions in mm (in)

  
 Guided Cylinders  
 P5T Series  
 P5L Series  
 HB Series  
 P5E Series  
 XL Series



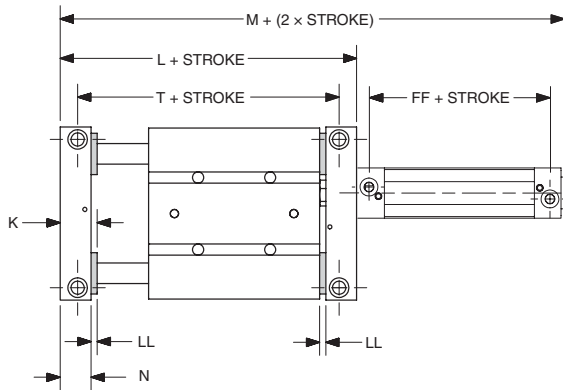
For inventory, lead times, and kit lookup, visit [www.pdnplu.com](http://www.pdnplu.com)

Options

**Bumpers (B)**

Bumpers absorb shock, reduce noise and permit faster cycle times, thereby increasing production rates. They can be placed on the extend, retract or both positions.

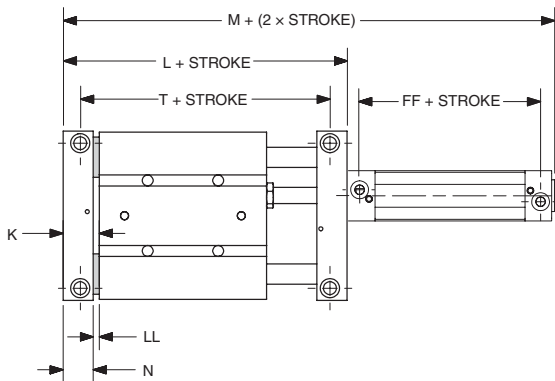
**Bumpers Both Ends (BB)**



Bore	K	L (P1D)	L (SRM)	M (P1D)	M (SRM)	N	T	FF (P1D)	LL
20	24 (0.9)	N/A	149 (5.8)	N/A	211 (8.3)	18 (0.7)	126 (5.0)	N/A	6 (0.2)
25	30 (1.2)	N/A	187 (7.3)	N/A	258 (10.1)	24 (0.9)	163 (6.4)	N/A	6 (0.2)
32	32 (1.3)	213 (8.4)	206 (8.1)	310 (12.2)	287 (11.3)	26 (1.0)	176 (6.9)	68 (2.7)	6 (0.2)
40	36 (1.4)	244 (9.6)	238 (9.4)	353 (13.9)	317 (12.5)	30 (1.2)	204 (8.0)	77 (3.0)	6 (0.2)
50	41 (1.6)	308 (12.1)	303 (11.9)	418 (16.4)	400 (15.7)	35 (1.4)	260 (10.2)	78 (3.1)	6 (0.2)
63	48 (1.9)	362 (14.2)	312 (12.3)	486 (19.1)	400 (15.7)	42 (1.7)	310 (12.2)	89 (3.5)	6 (0.2)
80	60 (2.4)	443 (17.4)	440 (17.3)	575 (22.6)	539 (21.2)	54 (2.1)	380 (15.0)	96 (3.8)	6 (0.2)
100	72 (2.8)	534 (21.0)	N/A	676 (26.6)	N/A	66 (2.6)	458 (18.0)	102 (4.0)	6 (0.2)

Dimensions in mm (in)

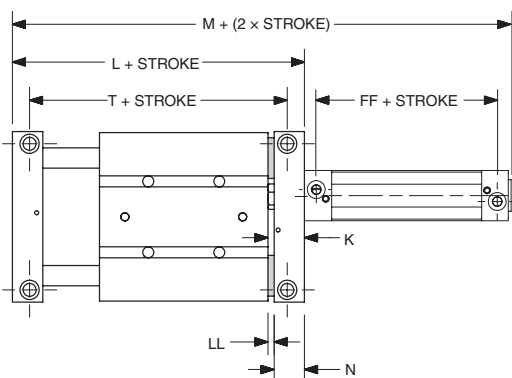
**Bumpers, Extend Only (BN)**



Bore	K	L (P1D)	L (SRM)	M (P1D)	M (SRM)	N	T	FF (P1D)	LL
20	24 (0.9)	N/A	146 (5.7)	N/A	208 (8.1)	18 (0.7)	123 (4.8)	N/A	6 (0.2)
25	30 (1.2)	N/A	184 (7.2)	N/A	255 (10.0)	24 (0.9)	159 (6.3)	N/A	6 (0.2)
32	32 (1.3)	210 (8.2)	203 (8.0)	307 (12.0)	284 (11.2)	26 (1.0)	173 (6.8)	68 (2.7)	6 (0.2)
40	36 (1.4)	241 (9.5)	235 (9.2)	350 (13.7)	314 (12.3)	30 (1.2)	201 (7.9)	77 (3.0)	6 (0.2)
50	41 (1.6)	305 (12.0)	300 (11.8)	415 (16.3)	397 (15.6)	35 (1.4)	257 (10.1)	78 (3.1)	6 (0.2)
63	48 (1.9)	359 (14.1)	309 (12.1)	483 (19.0)	397 (15.6)	42 (1.7)	307 (12.1)	89 (3.5)	6 (0.2)
80	60 (2.4)	440 (17.3)	437 (17.2)	572 (22.5)	536 (21.1)	54 (2.1)	377 (14.8)	96 (3.8)	6 (0.2)
100	72 (2.8)	531 (20.9)	N/A	673 (26.5)	N/A	66 (2.6)	455 (17.9)	102 (4.0)	6 (0.2)

Dimensions in mm (in)

**Bumpers on Retract Only (NB)**



Bore	K (P1D)	K (SRM)	L (P1D)	L (SRM)	M (P1D)	M (SRM)	N (P1D)	N (SRM)	T	FF (P1D)	LL
20	N/A	24 (0.9)	N/A	146 (5.7)	N/A	208 (8.1)	N/A	18 (0.7)	123 (4.8)	N/A	6 (0.2)
25	N/A	30 (1.2)	N/A	184 (7.2)	N/A	255 (10.0)	N/A	24 (0.9)	159 (6.3)	N/A	6 (0.2)
32	41 (1.6)	34 (1.3)	210 (8.2)	203 (8.0)	307 (12.0)	284 (11.2)	35 (1.4)	28 (1.1)	173 (6.8)	68 (2.7)	6 (0.2)
40	42 (1.7)	36 (1.4)	241 (9.5)	235 (9.2)	350 (13.7)	314 (12.3)	36 (1.4)	30 (1.2)	201 (7.9)	77 (3.0)	6 (0.2)
50	51 (2.0)	46 (1.8)	305 (12.0)	300 (11.8)	415 (16.3)	397 (15.6)	45 (1.7)	40 (1.6)	257 (10.1)	78 (3.1)	6 (0.2)
63	53 (2.1)	48 (1.9)	359 (14.1)	309 (12.1)	483 (19.0)	397 (15.6)	47 (1.8)	42 (1.7)	307 (12.1)	89 (3.5)	6 (0.2)
80	63 (2.5)	60 (2.4)	440 (17.3)	437 (17.2)	572 (22.5)	536 (21.1)	57 (2.2)	54 (2.1)	377 (14.8)	96 (3.8)	6 (0.2)
100	72 (2.8)	N/A	531 (20.9)	N/A	673 (26.5)	N/A	66 (2.6)	N/A	455 (17.9)	102 (4.0)	6 (0.2)

Dimensions in mm (in)



For inventory, lead time, and kit lookup, visit [www.pdnplu.com](http://www.pdnplu.com)

E65

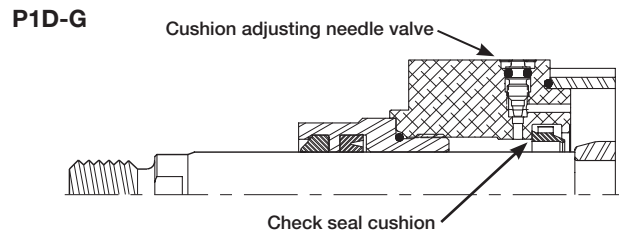
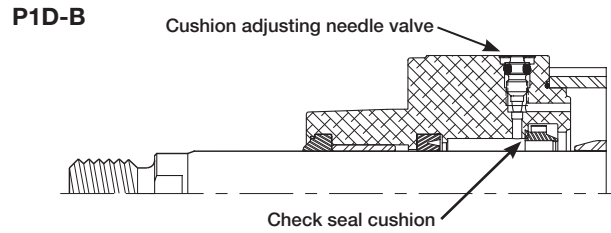
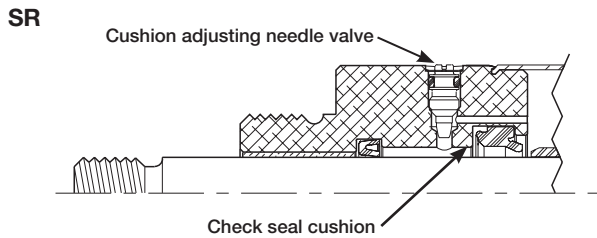
**Parker Hannifin Corporation**  
Pneumatic Division  
Richland, Michigan  
[www.parker.com/pneumatics](http://www.parker.com/pneumatics)

Options

Cylinder Cushions

Fully adjustable cylinder cushions can be provided to reduce speed and energy at the end of cylinder stroke.

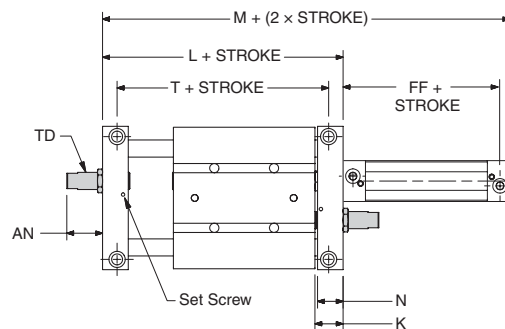
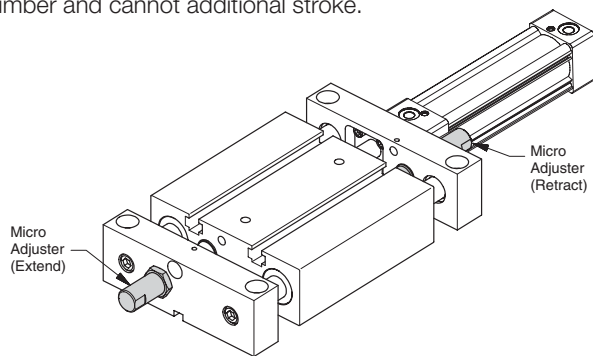
**Note:** If stroke adjustment is used in conjunction with cylinder cushions, the cushion effectiveness may be affected.



Micro Adjusters (EE)

Micro adjusters can be used as an accurate and fine adjustment of end of stroke position. Actual per end stroke adjustment depends on model size. See chart below. Micro adjusters must be ordered as both ends only. Caution should be used as cushion effectiveness may be affected.

**Note:** Using micro adjusters will only reduce the actuator stroke from a maximum value given in the actuator part number and cannot additional stroke.



Bore	N (P1D)	N (SRM)	K (P1D)	K (SRM)	L (P1D)	L (SRM)	M (P1D)	M (SRM)	T	TD	FF	AN
20	N/A	18 (0.7)	N/A	21 (0.8)	N/A	143 (5.6)	N/A	205 (8.1)	120 (4.7)	M12x1.5	N/A	42 (1.7)
25	N/A	24 (0.9)	N/A	27 (1.1)	N/A	181 (7.1)	N/A	252 (9.9)	156 (6.1)	M14x1.5	N/A	36 (1.4)
32	35 (1.4)	28 (1.1)	38 (1.5)	31 (1.2)	207 (8.1)	200 (7.8)	304 (11.9)	281 (11.1)	170 (6.7)	M14x1.5	68 (2.7)	34 (1.3)
40	36 (1.4)	30 (1.2)	39 (1.5)	33 (1.3)	238 (9.4)	232 (9.1)	347 (13.6)	311 (12.2)	198 (7.8)	M20x1.5	77 (3.0)	42 (1.7)
50	45 (1.7)	40 (1.6)	48 (1.9)	43 (1.7)	302 (11.9)	297 (11.7)	412 (16.2)	394 (15.5)	254 (10.0)	M25x1.5	78 (3.1)	53 (2.1)
63	47 (1.8)	42 (1.7)	50 (2.0)	45 (1.8)	356 (14.0)	306 (12.0)	480 (18.9)	394 (15.5)	304 (12.0)	M25x1.5	89 (3.5)	77 (3.0)
80	57 (2.2)	54 (2.1)	60 (2.4)	57 (2.2)	437 (17.2)	434 (17.1)	569 (22.4)	533 (21.0)	374 (14.7)	M33x1.5	96 (3.8)	52 (2.0)
100	66 (2.6)	N/A	69 (2.7)	N/A	528 (20.7)	N/A	670 (26.4)	N/A	452 (17.8)	M36x1.5	102 (4.0)	40 (1.6)

Dimensions in mm (in)



For inventory, lead times, and kit lookup, visit [www.pdnplu.com](http://www.pdnplu.com)

**Guided Cylinders**  
 P5T Series  
 P5L Series  
 HB Series  
 P5E Series  
 XL Series

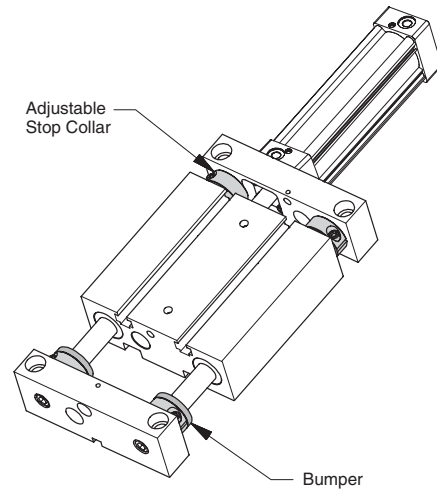
Options

**Bumpers and Adjustable Stop Collars**

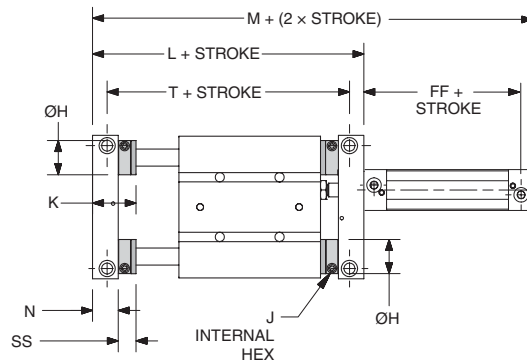
Bumpers provide end of stroke noise reduction. Bumpers can be used in conjunction with adjustable stop collars to provide adjustment. When a bumper is specified in the extend stroke a stop collar is provided.

Bumpers provide little energy absorption. If high speeds are present consult the kinetic energy section of this catalog to determine if cylinder cushions or shock absorbers are recommended.

A properly adjusted bumper and stop collar will prevent the cylinder from bottoming on the cylinder end cap thus increasing cylinder life.



**Bumpers and Adjustable Stop Collars, Both Ends (KK)**



Bore	Hs	Ho	Js	Jo	Ks	Ko	Ls (P1D)	Lo (P1D)	Ls (SRM)	Lo (SRM)	Ms (P1D)	Mo (P1D)	Ms (SRM)	Mo (SRM)	N	Ts	To	FF	SSs	SSo
20	24 (0.9)	28 (1.1)	2.5 (0.1)	3 (0.1)	33 (1.3)	35 (1.4)	N/A	N/A	167 (6.6)	171 (6.7)	N/A	N/A	229 (9.0)	233 (9.2)	18 (0.7)	144 (5.7)	148 (5.8)	N/A	15 (0.6)	17 (0.7)
25	28 (1.1)	34 (1.3)	3 (0.1)	4 (0.2)	41 (1.6)	43 (1.7)	N/A	N/A	209 (8.2)	213 (8.4)	N/A	N/A	280 (11.0)	284 (11.2)	24 (0.9)	184 (7.2)	188 (7.4)	N/A	17 (0.7)	19 (0.7)
32	34 (1.3)	40 (1.6)	4 (0.2)	5 (0.2)	45 (1.8)	47 (1.9)	239 (9.4)	243 (9.6)	232 (9.1)	236 (9.3)	336 (13.2)	340 (13.4)	313 (12.3)	317 (12.5)	26 (1.0)	202 (8.0)	206 (8.1)	68 (2.7)	19 (0.7)	21 (0.8)
40	40 (1.6)	45 (1.8)	5 (0.2)	5 (0.2)	51 (2.0)	51 (2.0)	274 (10.7)	274 (10.7)	268 (10.6)	268 (10.6)	383 (15.1)	383 (15.1)	347 (13.6)	347 (13.6)	30 (1.2)	234 (9.2)	234 (9.2)	77 (3.0)	21 (0.8)	21 (0.8)
50	45 (1.8)	54 (2.1)	5 (0.2)	5 (0.2)	56 (2.2)	56 (2.2)	338 (13.3)	338 (13.3)	333 (13.1)	333 (13.1)	448 (17.6)	448 (17.6)	430 (16.9)	430 (16.9)	35 (1.4)	290 (11.4)	290 (11.4)	78 (3.1)	21 (0.8)	21 (0.8)
63	54 (2.1)	60 (2.4)	5 (0.2)	5 (0.2)	63 (2.5)	63 (2.5)	392 (15.4)	392 (15.4)	342 (13.5)	342 (13.5)	516 (20.3)	516 (20.3)	430 (16.9)	430 (16.9)	42 (1.7)	340 (13.4)	340 (13.4)	89 (3.5)	21 (0.8)	21 (0.8)
80	60 (2.4)	78 (3.1)	5 (0.2)	6 (0.2)	75 (3.0)	79 (3.1)	473 (18.6)	481 (18.9)	470 (18.5)	478 (18.8)	605 (23.8)	613 (24.1)	569 (22.4)	577 (22.7)	54 (2.1)	410 (16.1)	418 (16.5)	96 (3.8)	21 (0.8)	25 (1.0)
100	78 (3.1)	88 (3.5)	6 (0.2)	6 (0.2)	91 (3.6)	91 (3.6)	572 (22.5)	572 (22.5)	N/A	N/A	714 (28.1)	714 (28.1)	N/A	N/A	66 (2.6)	496 (19.5)	496 (19.5)	102 (4.0)	25 (1.0)	25 (1.0)

Dimensions in mm (in)



Guided Cylinders

P5T Series

P5L Series

HB Series

P5E Series

XL Series



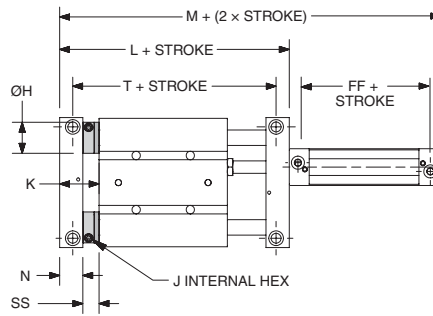
For inventory, lead time, and kit lookup, visit [www.pdnplu.com](http://www.pdnplu.com)

E67

Parker Hannifin Corporation  
Pneumatic Division  
Richland, Michigan  
[www.parker.com/pneumatics](http://www.parker.com/pneumatics)

Options

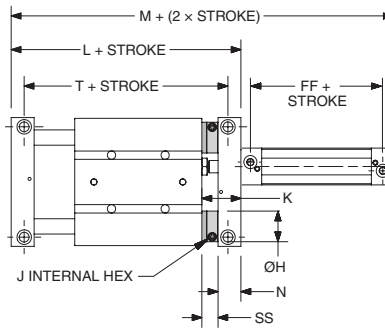
Bumpers and Adjustable Stop Collars, Extend Only (KN)



Dimensions in mm (in)

Bore	Hs	Ho	Js	Jo	Ks	Ko	Ls (P1D)	Lo (P1D)	Ls (SRM)	Lo (SRM)	Ms (P1D)	Mo (P1D)	Ms (SRM)	Mo (SRM)	N	Ts	To	FF (P1D)	SSs	SSo
20	24 (0.9)	28 (1.1)	2.5 (0.1)	3 (0.1)	33 (1.3)	35 (1.4)	N/A	N/A	155 (6.1)	159 (6.2)	N/A	N/A	217 (8.5)	219 (8.6)	18 (0.7)	132 (5.2)	136 (5.4)	N/A	15 (0.6)	17 (0.7)
25	28 (1.1)	34 (1.3)	3 (0.1)	4 (0.2)	41 (1.6)	43 (1.7)	N/A	N/A	195 (7.7)	199 (7.8)	N/A	N/A	266 (10.5)	268 (10.5)	24 (0.9)	170 (6.7)	174 (6.9)	N/A	17 (0.7)	19 (0.7)
32	34 (1.3)	40 (1.6)	4 (0.2)	5 (0.2)	45 (1.8)	47 (1.9)	223 (8.8)	225 (8.9)	216 (8.5)	220 (8.7)	320 (12.6)	322 (12.7)	297 (11.7)	299 (11.7)	26 (1.0)	186 (7.3)	190 (7.5)	68 (2.7)	19 (0.7)	21 (0.8)
40	40 (1.6)	45 (1.8)	5 (0.2)	5 (0.2)	51 (2.0)	51 (2.0)	256 (10.0)	256 (10.0)	250 (9.8)	250 (9.8)	365 (14.4)	365 (14.4)	329 (13.9)	329 (13.9)	30 (1.2)	216 (8.5)	216 (8.5)	77 (3.0)	21 (0.8)	21 (0.8)
50	45 (1.8)	54 (2.1)	5 (0.2)	5 (0.2)	56 (2.2)	56 (2.2)	320 (12.6)	320 (12.6)	315 (12.4)	315 (12.4)	430 (16.9)	430 (16.9)	412 (16.2)	412 (16.2)	35 (1.4)	272 (10.7)	272 (10.7)	78 (3.1)	21 (0.8)	21 (0.8)
63	54 (2.1)	60 (2.4)	5 (0.2)	5 (0.2)	63 (2.5)	63 (2.5)	374 (14.7)	374 (14.7)	324 (12.7)	324 (12.7)	498 (19.6)	498 (19.6)	412 (16.2)	412 (16.2)	42 (1.7)	322 (12.7)	322 (12.7)	89 (3.5)	21 (0.8)	21 (0.8)
80	60 (2.4)	78 (3.1)	5 (0.2)	6 (0.2)	75 (3.0)	79 (3.1)	455 (17.9)	459 (18.1)	452 (17.8)	460 (18.1)	587 (23.1)	591 (23.3)	551 (21.7)	555 (21.9)	54 (2.1)	392 (15.4)	400 (15.7)	96 (3.8)	21 (0.8)	25 (1.0)
100	78 (3.1)	88 (3.5)	6 (0.2)	6 (0.2)	91 (3.6)	91 (3.6)	550 (21.6)	550 (21.6)	N/A	N/A	692 (27.2)	692 (27.2)	N/A	N/A	66 (2.6)	474 (18.7)	474 (18.7)	102 (4.0)	25 (1.0)	25 (1.0)

Bumpers and Adjustable Stop Collars, Retract Only (NK)



Dimensions in mm (in)

Bore	Hs	Ho	Js	Jo	Ks	Ko	Ls (P1D)	Lo (P1D)	Ls (SRM)	Lo (SRM)	Ms (P1D)	Mo (P1D)	Ms (SRM)	Mo (SRM)	N (P1D)	N (SRM)	N	Ts	To	FF (P1D)	SSs	SSo
20	24 (0.9)	28 (1.1)	2.5 (0.1)	3 (0.1)	33 (1.3)	35 (1.4)	N/A	N/A	155 (6.1)	159 (6.2)	N/A	N/A	217 (8.5)	219 (8.6)	N/A	18 (0.7)	18 (0.7)	132 (5.2)	136 (5.4)	N/A	15 (0.6)	17 (0.7)
25	28 (1.1)	34 (1.3)	3 (0.1)	4 (0.2)	41 (1.6)	43 (1.7)	N/A	N/A	195 (7.7)	199 (7.8)	N/A	N/A	266 (10.5)	268 (10.5)	N/A	24 (0.9)	24 (0.9)	170 (6.7)	174 (6.9)	N/A	17 (0.7)	19 (0.7)
32	34 (1.3)	40 (1.6)	4 (0.2)	5 (0.2)	45 (1.8)	47 (1.9)	223 (8.8)	225 (8.9)	216 (8.5)	220 (8.7)	320 (12.6)	322 (12.7)	297 (11.7)	299 (11.7)	35 (1.4)	28 (1.1)	26 (1.0)	186 (7.3)	190 (7.5)	68 (2.7)	19 (0.7)	21 (0.8)
40	40 (1.6)	45 (1.8)	5 (0.2)	5 (0.2)	51 (2.0)	51 (2.0)	256 (10.0)	256 (10.0)	250 (9.8)	250 (9.8)	365 (14.4)	365 (14.4)	329 (13.9)	329 (13.9)	36 (1.4)	30 (1.2)	30 (1.2)	216 (8.5)	216 (8.5)	77 (3.0)	21 (0.8)	21 (0.8)
50	45 (1.8)	54 (2.1)	5 (0.2)	5 (0.2)	56 (2.2)	56 (2.2)	320 (12.6)	320 (12.6)	315 (12.4)	315 (12.4)	430 (16.9)	430 (16.9)	412 (16.2)	412 (16.2)	45 (1.8)	40 (1.6)	40 (1.6)	272 (10.7)	272 (10.7)	78 (3.1)	21 (0.8)	21 (0.8)
63	54 (2.1)	60 (2.4)	5 (0.2)	5 (0.2)	63 (2.5)	63 (2.5)	374 (14.7)	374 (14.7)	324 (12.7)	324 (12.7)	498 (19.6)	498 (19.6)	412 (16.2)	412 (16.2)	47 (1.8)	42 (1.7)	42 (1.7)	322 (12.7)	322 (12.7)	89 (3.5)	21 (0.8)	21 (0.8)
80	60 (2.4)	78 (3.1)	5 (0.2)	6 (0.2)	75 (3.0)	79 (3.1)	455 (17.9)	459 (18.1)	452 (17.8)	460 (18.1)	587 (23.1)	591 (23.3)	551 (21.7)	555 (21.9)	57 (2.2)	54 (2.1)	54 (2.1)	392 (15.4)	400 (15.7)	96 (3.8)	21 (0.8)	25 (1.0)
100	78 (3.1)	88 (3.5)	6 (0.2)	6 (0.2)	91 (3.6)	91 (3.6)	550 (21.6)	550 (21.6)	N/A	N/A	692 (27.2)	692 (27.2)	N/A	N/A	66 (2.6)	N/A	N/A	474 (18.7)	474 (18.7)	102 (4.0)	25 (1.0)	25 (1.0)



For inventory, lead times, and kit lookup, visit [www.pdnplu.com](http://www.pdnplu.com)

E68

Parker Hannifin Corporation  
Pneumatic Division  
Richland, Michigan  
[www.parker.com/pneumatics](http://www.parker.com/pneumatics)



## Options

## Guided Pneumatic Cylinders P5L Series

### Fluorocarbon Seals (V)

Standard nitrile seals are used for applications within the temperatures of -18° to 74°C (0° to 165°F). For high temperature applications, up to 121°C (250°F), fluorocarbon seals are available.

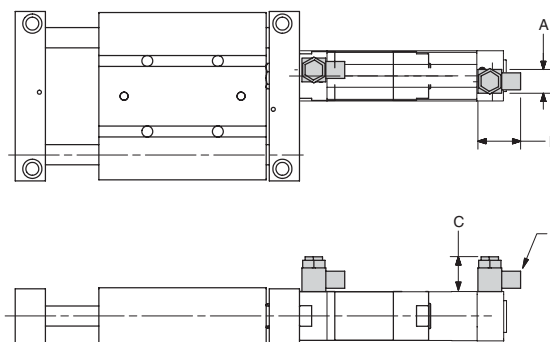
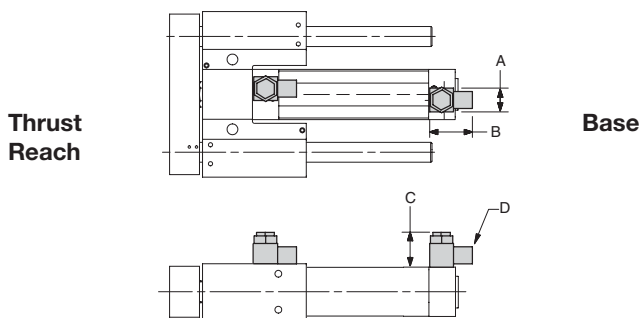
When temperatures exceed 60°C (140°F) other components may not be applicable. See chart for temperature ratings of other commonly used components.

Option	Temperature range	
Shock Absorbers	0° to 66°C	32° to 150°F
Bumpers	-18° to 93°C	0° to 200°F
Piston Magnets	-18° to 74°C	0° to 165°F
Sensors	-10° to 60°C	14° to 140°F

### Flow Controls (P, F, B, N)

Right angle flow controls provide speed control. It is recommended that applications involving heavy loads use flow controls to provide maximum cylinder life.

Parker flow controls are available in Prestolok (push-in) and threaded style connections with the ability to rotate the head 360°.

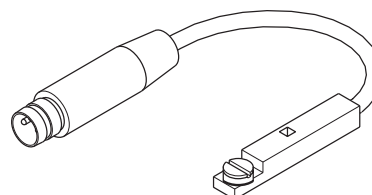


Bore	NPT Cylinder Port								BSPT Cylinder Port							
	Threaded (N)				Prestolok (F)				Threaded (B)				Prestolok (P)			
	A	B	C	D	A	B	C	D	A	B	C	D	A	B	C	D
20, 25, 32, 40	17.2 (0.68)	28.4 (1.12)	55.4 (2.18)	1/8	17.2 (0.68)	25.2 (0.99)	55.4 (2.18)	1/4** tube	14.4 (0.57)	25.4 (1.00)	28.5 (1.12)	1/8	14.4 (0.57)	31.6 (1.24)	28.5 (1.12)	6mm tube
50, 63	17.2 (0.68)	32.4 (1.27)	65.2 (2.57)	1/4	17.2 (0.68)	38.3 (1.51)	65.2 (2.57)	3/8" tube	18.4 (0.72)	34.3 (1.35)	27.4 (1.08)	1/4	18.4 (0.72)	41.3 (1.63)	34 (1.34)	10mm tube
80	25.0 (0.98)	39.0 (1.54)	80.2 (3.16)	3/8	30.0 (1.18)	47.4 (1.87)	98.0 (3.86)	3/8" tube	21.6 (0.85)	40.2 (1.58)	34.0 (1.34)	3/8	21.6 (0.85)	46.7 (1.84)	44 (1.73)	12mm tube
100	30.0 (1.18)	45.5 (1.79)	98.0 (3.86)	1/2	30.0 (1.18)	51.4 (2.02)	98.0 (3.86)	1/2" tube	26.5 (1.04)	49.1 (1.93)	42.0 (1.65)	1/2	26.5 (1.04)	52.1 (2.05)	52 (2.05)	12mm tube

\*1/8" on 20 and 25mm bore  
Dimensions in mm (in)

### Reed and Solid State Sensors

The P5L series guided cylinder includes a standard magnetic piston to allow for field installation of reed or solid state sensors. The sensor, bracket and cable must be ordered separately from the Electronic Sensors section of this catalog.



For inventory, lead time, and kit lookup, visit [www.pdnplu.com](http://www.pdnplu.com)

**M**

Guided  
Cylinders

---

P5T  
Series

---

P5L  
Series

---

HB  
Series

---

P5E  
Series

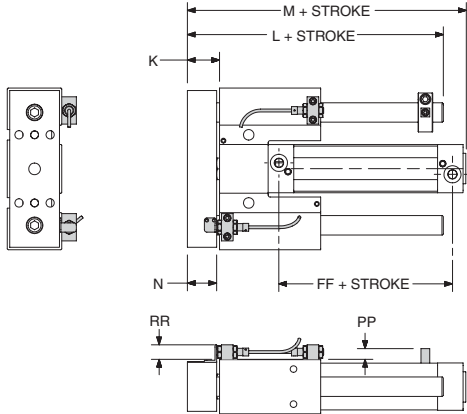
---

XL  
Series

Proximity Sensors

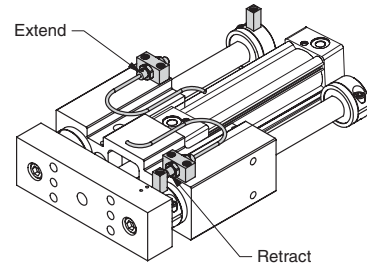
8mm proximity sensors may be ordered as part of the P5L ordering code.

A P5L can also be ordered prepared for proximity sensors which would include all the brackets necessary to mount either 8mm or 12mm proximity sensors. See Electronic Sensors section for specifications and part numbers.

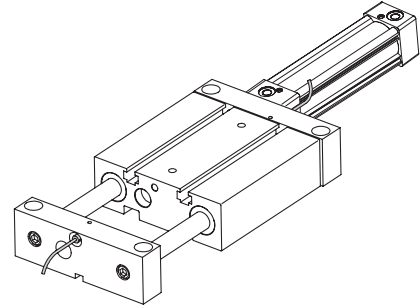


Thrust/Reach

Drawing illustrates proximity sensor and bumper options.



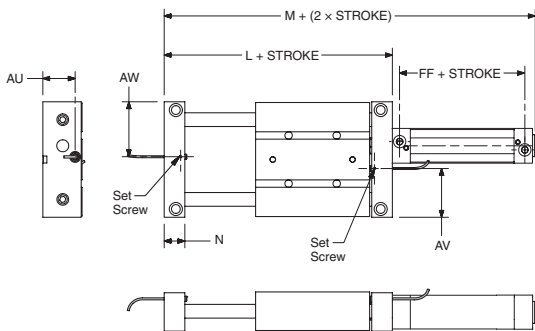
Base Slide



Dimensions – Thrust / Reach

Bore	K	Thrust		Reach						N	FF (P1D)	RR		
		Ls*	Lo*	M (P1D)	M (SRM)	Ls*	Lo*	M (P1D)	M (SRM)			8mm	12mm	
20	20 (0.8)	100 (3.9)	102 (4.0)	N/A	122 (4.4)	138 (5.4)	140 (5.5)	N/A	147 (5.8)	17 (0.7)	N/A	13 (0.5)	17 (0.7)	NA
25	25 (1.0)	123 (4.8)	127 (5.0)	N/A	126 (4.9)	169 (6.7)	173 (6.8)	N/A	172 (6.7)	22 (0.9)	N/A	13 (0.5)	15 (0.6)	22 (0.9)
32	27 (1.1)	136 (5.4)	140 (5.5)	184 (7.2)	124 (4.8)	192 (7.6)	196 (7.7)	238 (9.4)	225 (8.8)	24 (0.9)	68 (2.7)	12.5 (0.5)	15 (0.6)	22 (0.9)
40	33 (1.3)	166 (6.5)	166 (6.5)	192 (7.5)	177 (6.9)	228 (9.0)	228 (9.0)	254 (9.9)	239 (9.4)	30 (1.2)	77 (3.0)	13 (0.5)	15 (0.6)	22 (0.9)
50	39 (1.5)	198 (7.8)	198 (7.8)	214 (8.4)	220 (8.6)	284 (11.2)	284 (11.2)	299 (11.7)	306 (12.0)	36 (1.4)	78 (3.1)	13.5 (0.5)	15 (0.6)	22 (0.9)
63	43 (1.7)	224 (8.8)	224 (8.8)	252 (9.9)	237 (9.9)	332 (13.1)	332 (13.1)	360 (14.2)	344 (13.5)	40 (1.6)	89 (3.5)	13 (0.5)	15 (0.6)	22 (0.9)
80	49 (1.9)	258 (10.2)	266 (10.5)	270 (10.6)	262 (10.3)	398 (15.7)	406 (16.0)	410 (16.1)	402 (15.8)	46 (1.8)	96 (3.8)	13.5 (0.5)	15 (0.6)	22 (0.9)
100	59 (2.3)	318 (12.5)	318 (12.5)	336 (13.2)	N/A	486 (19.1)	486 (19.1)	505 (19.8)	N/A	56 (2.2)	102 (4.0)	13 (0.5)	15 (0.6)	22 (0.9)

Dimensions – Base Slides



Bore	L (P1D)	L (SRM)	M (P1D)	M (SRM)	N	AU	AV	AW	FF (P1D)
20	N/A	143 (5.6)	N/A	205 (8.1)	18 (0.7)	22 (0.9)	43 (1.7)	51 (2.0)	N/A
25	N/A	181 (7.1)	N/A	252 (9.9)	24 (0.9)	29 (1.1)	51 (2.0)	62 (2.4)	N/A
32	207 (8.1)	200 (7.9)	304 (11.9)	281 (11.0)	26 (1.0)	35 (1.4)	58 (2.3)	69 (2.7)	68 (2.7)
40	238 (9.4)	232 (9.1)	347 (13.6)	311 (12.2)	30 (1.2)	47 (1.9)	71 (2.8)	80 (3.1)	77 (3.0)
50	302 (11.9)	297 (11.7)	412 (16.2)	394 (15.5)	35 (1.4)	60 (2.4)	95 (3.7)	101 (4.0)	78 (3.1)
63	356 (14.0)	306 (12.0)	480 (18.9)	394 (15.5)	42 (1.7)	73 (2.9)	114 (4.5)	121 (4.8)	89 (3.5)
80	437 (17.2)	434 (17.0)	569 (22.4)	533 (20.9)	54 (2.1)	92 (3.6)	144 (5.7)	145 (5.7)	96 (3.8)
100	528 (20.8)	N/A	670 (26.4)	N/A	66 (2.6)	109 (4.3)	169 (6.7)	180 (7.1)	102 (4.0)

Dimensions in mm (in)

\* s = standard; o = oversized



For inventory, lead times, and kit lookup, visit [www.pdnplu.com](http://www.pdnplu.com)

**Service Kits: P1D-B, P1D-T, P1D-C,  
and P1D-F Versions**

Cylinder bore mm	P1D cylinder version Consisting of: piston, rod and o-ring seals
32	SK032P1D01
40	SK040P1D01
50	SK050P1D01
63	SK063P1D01
80	SK080P1D01
100	SK100P1D01
125	SK125P1D01

**Grease for P1D Series**



Size	Part number
30g (standard)	9127394541

**Gland Service Kits: P1D-G and P1D-E Versions**

Bore size mm	Rod dia. mm	Rod no.	RG-rod gland cartridge kit Consisting of: rod gland, seals, and wiper	
			Nitrile seals part number	Fluorocarbon seals part number
32	12	1	RG0P1D0121	RG0P1D0125
40	16	1	RG0P1D0161	RG0P1D0165
50 & 63	20	1	RG0P1D0201	RG0P1D0205
80 & 100	25	1	RG0P1D0251	RG0P1D0255
125	32	1	RG0P1D0321	RG0P1D0325

RK-rod seal kit Consisting of: gland seals, and wiper	
Nitrile seals part number	Fluorocarbon seals Part number
RK0P1D0121	RK0P1D0125
RK0P1D0161	RK0P1D0165
RK0P1D0201	RK0P1D0205
RK0P1D0251	RK0P1D0255
RK0P1D0321	RK0P1D0325

**Piston and End Seal Service Kits: P1D-G and P1D-E Versions**

Bore size mm	PK – piston seal kit Consisting of: piston seals, wear ring, and magnetic strip (nitrile only)	
	Nitrile seals part number	Fluorocarbon seals part number
32	PK032P1D01	PK032P1D05
40	PK040P1D01	PK040P1D05
50	PK050P1D01	PK050P1D05
63	PK063P1D01	PK063P1D05
80	PK080P1D01	PK080P1D05
100	PK100P1D01	PK100P1D05
125	PK125P1D01	PK125P1D05

CB – cylinder body end seal kit Consisting of: end seal o-rings	
Nitrile seals part number	Fluorocarbon seals part number
CB032P1D01	CB032P1D05
CB040P1D01	CB040P1D05
CB050P1D01	CB050P1D05
CB063P1D01	CB063P1D05
CB080P1D01	CB080P1D05
CB100P1D01	CB100P1D05
CB125P1D01	CB125P1D05

**P**  
Guided  
Cylinders

P5T  
Series

P5L  
Series

HB  
Series

P5E  
Series

XL  
Series



For inventory, lead time, and kit lookup, visit [www.pdnplu.com](http://www.pdnplu.com)

**HB Series**

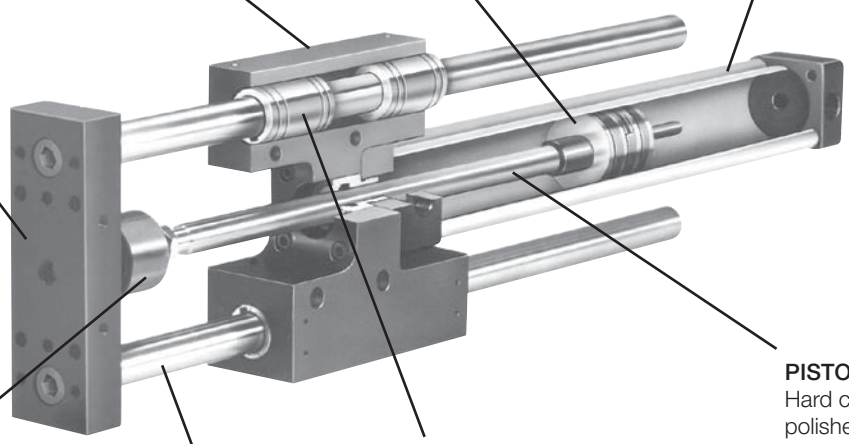
**Model HBT Shown**

**TOOLING PLATE**  
Precision machined from aluminum and then anodized, the tooling plate allows mounting on two sides. Standard dowel pin holes provide accurate mounting.

**BODY**  
A machined aluminum one-piece anodized body with tapped and counterbored through holes on three faces for mounting flexibility. Standard dowel pin holes provide accurate mounting.

**CYLINDER PISTON**  
Aluminum piston with nylon wearband eliminates metal-to-metal contact. This increases cylinder life especially when the support shafts deflect under load. Magnetic piston is standard on all HB slides.

**CYLINDER BODY**  
Extruded aluminum profile cylinder body offers integrated sensor grooves to minimize sensor installation time, maximize sensor protection and eliminate the need for brackets. Grooves readily accept both Global and Mini-Global Sensors. Single corner lobe of extrusion will accept legacy 2MA sensor brackets. Anodized and bright-dipped for corrosion resistance, maximum seal life and lower friction.



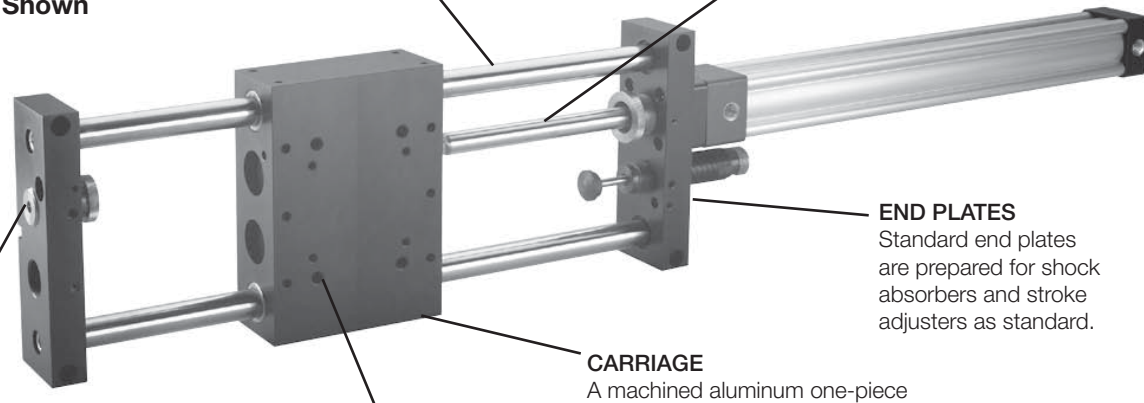
**ALIGNMENT COUPLER**  
For long stroke or heavy load applications, the alignment coupler allows the piston rod to self-center, thus increasing cylinder life. Not available for HBC Series due to shorter strokes.

**SUPPORT SHAFTS**  
Case hardened to Rc 60 - 65, support shafts are machined from high carbon alloy steel and chrome plated. Stainless steel and oversized shafting are available.

**BUSHINGS**  
Composite bushings with oversized shafting are available for higher loads and lower cost. Sealed recirculating ball bearings provide precise alignment with very low friction and wear.

**PISTON ROD**  
Hard chrome plated and polished piston rod of 100,000 PSI yield, high tensile strength steel, case hardened to Rc 50-54 for reliable performance, reduced friction and long rod seal life.

**Model HBB Shown**



**THREADED STROKE ADJUSTERS**  
Used to achieve precise end of stroke adjustment. Available with shock absorbers and optional shock pads to reduce noise.

**DIRECT MOUNTING**  
Tapped holes provide direct mounting capabilities to HBC Series.

**CARRIAGE**  
A machined aluminum one-piece anodized body with tapped and counterbored through holes on three faces for mounting flexibility. Standard dowel pin holes provide accurate mounting.

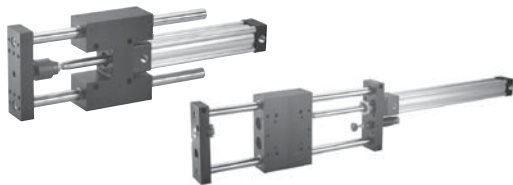
**END PLATES**  
Standard end plates are prepared for shock absorbers and stroke adjusters as standard.

	Guided Cylinders
P5T Series	
P5L Series	
HB Series	
P5E Series	
XL Series	



For inventory, lead times, and kit lookup, visit [www.pdnplu.com](http://www.pdnplu.com)

Features



- Medium duty to extremely heavy duty linear motion
- Powered by the 4MA NFPA cylinder, with ISO options available
- Bore sizes 1-1/2", 2", and 2-1/2"
- Thrust, reach, and compact versions available
- Shock absorber, bumpers/stop collars, and proximity sensor options available

Operating information

Maximum Operating pressure: 100 PSIG (7 bar), air – 4MAJ cylinder  
 150 PSIG (10 bar), air – P1D cylinder  
 250 PSIG (17 bar), air – 4MA and 2A cylinders  
 400 PSIG (28 bar), oil – 4ML cylinder only  
 750 PSIG (52 bar), oil – 3L cylinder only

Cylinder Temperature range: Standard seals 0°F to 165°F (-18°C to 74°C)  
 Fluorocarbon seals\* 0°F to 250°F (-18°C to 121°C)  
 \* See fluorocarbon seal option for high temperature applications.

Filtration requirements: 40 micron, dry filtered air

Ordering information

**HBT 25 - 08 A P1 T F 4A - B**

Series	
HBC	Compact slide
HBT	Thrust slide
HBR	Reach slide
HBB	Base slide

Model	
15	1-1/2" bore, 20mm shaft
20	2" bore, 25mm shaft
25	2-1/2" bore, 30mm shaft

Stroke length	
Order in 1" increments. <sup>4</sup>	
For 3-position units, specify intermediate and total stroke separated by a "/", i.e. 02/06.	
Consult factory for strokes over 36".	

Bushings	
T	Composite (standard)
D	Linear ball bearing
T1	Composite with oversized support shafts
TC	Composite with contaminant-tolerant seals

Design Series	
B	Current design level

Special Options	
Blank	Standard
(Two digit code assigned by factory and applies when any "X" appears in the model number or when special options or features are required.)	

Cylinder Options	
(More than one selection is possible)	
Blank	None
V	Fluorocarbon cylinder seals <sup>3</sup>
L1	Left hand assembly <sup>7</sup>
L3	Cylinder ports at position 3

Slide Configuration Options	
Blank	None
A	Shock absorber, both ends
A1	Shock absorber, extend only
A2	Shock absorber, retract only
A3	Shock ready, both ends
A4	Shock ready, extend <sup>7</sup>
A5	Shock ready, retract <sup>7</sup>
B	Bumpers both ends <sup>1</sup>
B1	Bumper & adjustable stop collar, extend only
B2	Bumper retract only
B3	Bumper & adjustable stop collar, retract only
B4	Bumper & adjustable stop collar, both ends
B5	Bumper & adjustable stop collar, both ends <sup>8</sup>
C	Cushions on cylinder, both ends <sup>2</sup>
C1	Cushion on cylinder, extend only <sup>2</sup>
C2	Cushion on cylinder, retract only <sup>2</sup>
E	Threaded stroke adjusters, both ends
E1	Stroke adjusters with shockpads, both ends <sup>8</sup>
E2	Stroke adjusters with shockpads, extend only <sup>8</sup>
E3	Stroke adjusters with shockpads, retract only <sup>8</sup>
X	Special slide configuration (please specify)

Proximity Sensor Options	
Blank	None
P	PNP, flying lead type
N	NPN, flying lead type
P1	PNP, plug-in connector
N1	NPN, plug-in connector
J	8mm sensor mounting bracket, no sensor supplied
J1	12mm sensor mounting bracket, no sensor supplied

Note: 8mm inductive proximity sensors are included with Options P, N, P1, N1. Magnetic piston is standard for 4MA, 4MAJ, 4ML and P1D cylinders. Order reed and solid state sensors separately for these cylinders from the Electronic Sensors section.

Other Options <sup>5</sup>	
(More than one selection is possible)	
Blank	None
F	Flow controls (prestolok)
G	Flow controls (NPT)
K	Stainless steel support shafting

Cylinder Type	
4A	4MA NFPA air cylinder, NPTF ports
4J	4MAJ NFPA air cylinder with manual override rodlock, NPTF ports, 100 PSIG max.
D	P1D ISO cylinder w/ removable gland, BSPP ports
D1	P1D ISO cylinder w/ removable gland, Standard Rodlock, BSPP ports
D2	P1D ISO cylinder w/ removable gland, manual override rodlock, BSPP ports
E	P1D ISO cylinder w/ removable gland, NPTF ports
E1	P1D ISO cylinder w/ removable gland, standard rodlock, NPTF ports
E2	P1D ISO cylinder w/ removable gland, manual override rodlock, NPTF ports
4L	4ML NFPA hydraulic cylinder, NPTF ports, 400 PSIG max. <sup>2</sup>
S	2A NFPA steel air cylinder, 250 PSIG max.
S1	3L NFPA steel hydraulic cylinder, 750 PSIG max. (Stop collars, bumpers, and flow controls not available with this option.) <sup>6</sup>
Q	No cylinder, NFPA cylinder mounting
Q1	No cylinder, ISO cylinder mounting
X	Special cylinder type (please specify)

**NOTES**

- Option B includes options B1 and B2.
- Cushions are not available with 4ML cylinders on HB products.
- Fluorocarbon seals not available with rodlock cylinders.
- P1D cylinders have strokes only in whole mm. The HB inch stroke will be changed (rounded up) to reflect this.
- Flow controls not available with hydraulic cylinder options.
- No bumpers, stop collars or flow controls.
- Not available on HBB series.
- Available for HBB series only.

Sensors

See section L for sensors.



For inventory, lead time, and kit lookup, visit [www.pdnplu.com](http://www.pdnplu.com)

E73

Parker Hannifin Corporation  
 Pneumatic Division  
 Richland, Michigan  
[www.parker.com/pneumatics](http://www.parker.com/pneumatics)



Guided Cylinders

P5T Series

P5L Series

HB Series

P5E Series

XL Series

**General Specifications**

**Specifications**

- Maximum operating pressure: 100 psi (air) – 4MAJ cylinder  
150 psi (air) – P1D cylinder  
250 psi (air) – 4MA and 2A cylinders  
400 psi (oil) – 4ML cylinder only  
750 psi (oil) – 3L cylinder only
- Operating characteristics: double acting
- Four support shaft sizes: 20, 25, 30 and 35 mm
- Stroke tolerance: +.030, -.000
- Mounting: unrestricted
- Operating temperature range (cylinder): Standard seals 0 to 165°F  
Fluorocarbon seals\* 0 to 250°F
- Filtration requirement: 40 micron filtered, dry air or filtered hydraulic oil (4ML or 3L)


\* See fluorocarbon seal option for high temperature applications. Not available for rod lock cylinders.

**Quick Reference Data**

Model	Support shaft diameter mm (in)	Oversized shaft diameter mm (in)	4MA, 4MAJ, 4ML NFPA cylinder bore size (in)	P1D ISO cylinder bore size (mm)	Force output on extend at 80 PSI (lb)	Force output on retract at 80 PSI (lb)
15	20 (0.79)	25 (0.98)	1½	40	142	117
20	25 (0.98)	30 (1.18)	2	50	251	226
25	30 (1.18)	35 (1.38)	2½	63	393	368

Model	Maximum suggested stroke, inches*				Weights, standard shaft (lb)					Weights, oversized shaft (lb)				
					Base unit				Per inch stroke	Base unit				Per inch stroke
	HBC	HBT	HBR	HBB	HBC	HBT	HBR	HBB		HBC	HBT	HBR	HBB	
15	8	24	30	30	6.54	8.86	12.76	11.05	0.48	7.24	9.83	14.20	11.92	0.63
20	10	30	36	36	11.57	14.35	24.02	18.65	0.64	12.60	15.67	26.19	19.81	0.83
25	12	36	42	42	20.57	24.45	42.03	31.78	0.85	22.03	25.69	44.50	33.32	1.08

\*Consult factory for longer strokes.

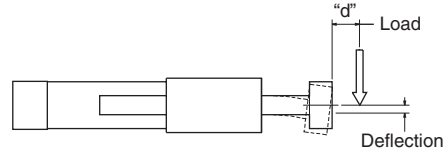

  
 Guided Cylinders
   
  
 P5T Series
   
  
 P5L Series
   
  
 HB Series
   
  
 P5E Series
   
  
 XL Series



For inventory, lead times, and kit lookup, visit [www.pdnplu.com](http://www.pdnplu.com)

**Horizontal Load Capacity & Deflection with Standard Shafting**

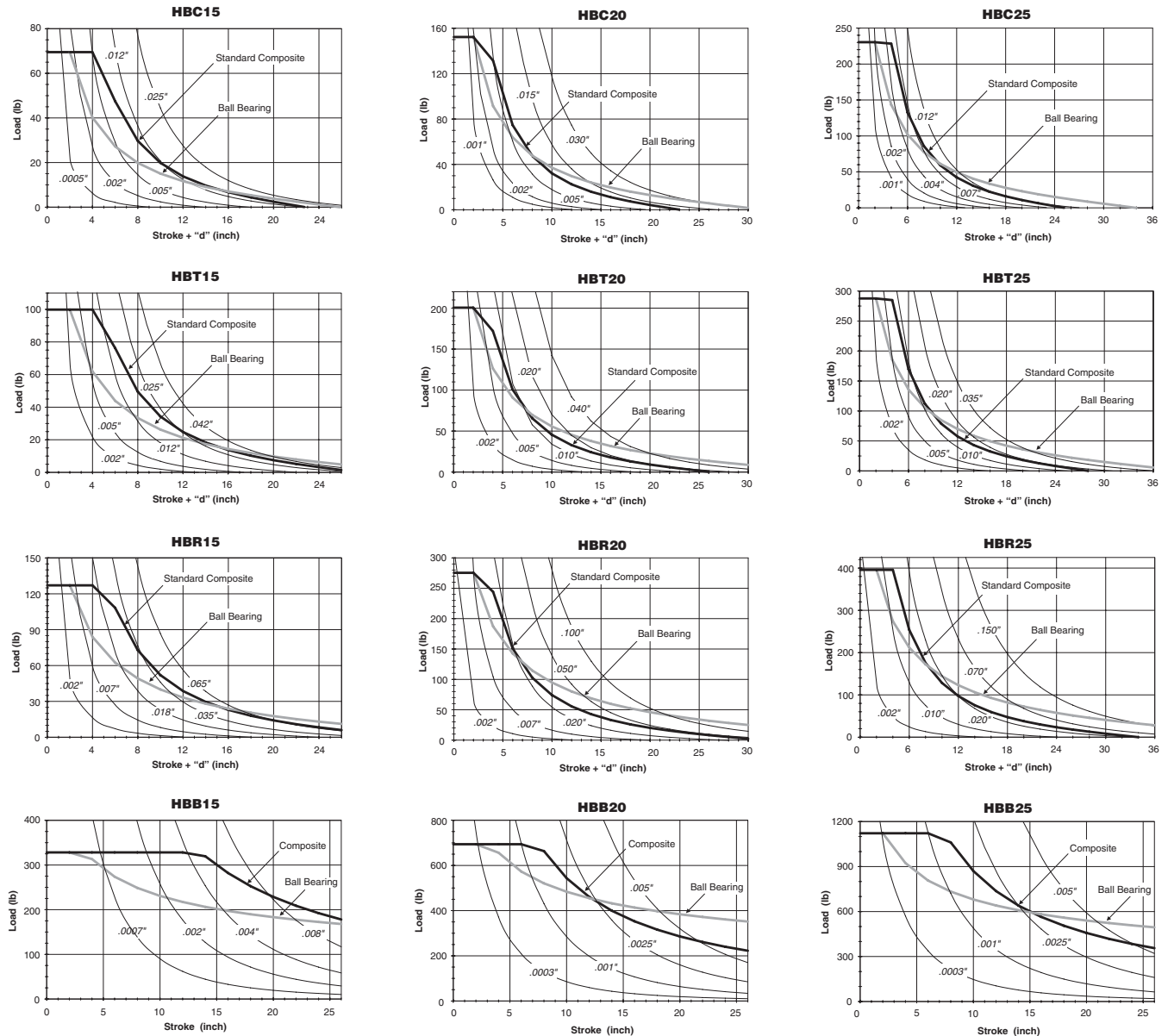
The graphs illustrate the side load vs. actuator stroke for the three HB slide sizes. Applied loads will cause a slight deflection of the support rods. The graphs include the weight of the support rods and tooling plate and are based on a bearing life equivalent to 10 million cycles for dynamic conditions. Higher dynamic loads will reduce cycle life. For static loads, multiply the information in the graph by 1.5.



**Note:** Actuator life may vary depending on the severity of the following variables:

- Acceleration
- Velocity
- Vibration
- Orientation

**EXAMPLE:**  
 An HBT15 with ball bearings and a "stroke+d" of 12" would have a load capacity of 20 lbs.



<b>M</b>	Guided Cylinders
P5T Series	P5L Series
P5E Series	XL Series



For inventory, lead time, and kit lookup, visit [www.pdnplu.com](http://www.pdnplu.com)

E75

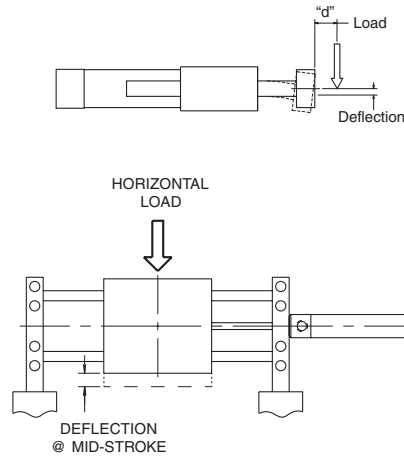
**Parker Hannifin Corporation**  
 Pneumatic Division  
 Richland, Michigan  
[www.parker.com/pneumatics](http://www.parker.com/pneumatics)

**Horizontal Load Capacity & Deflection with Oversized Shafting**

The graphs illustrate the side load vs. actuator stroke for the three HB slide sizes. Applied loads will cause a slight deflection of the support rods. Deflection distance is also shown. The graphs include the weight of the support rods and tooling plate and are based on a bearing life equivalent to 10 million cycles for dynamic conditions. Higher dynamic loads will reduce cycle life. For static loads, multiply the information in the graph by 1.5.

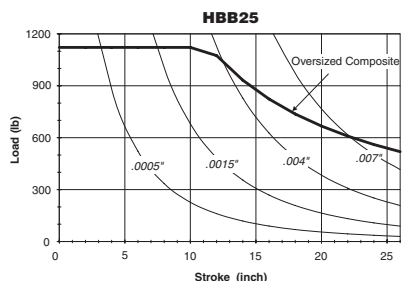
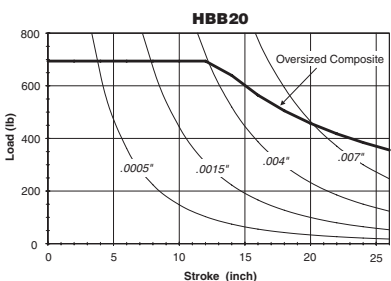
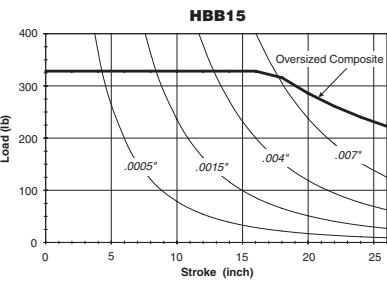
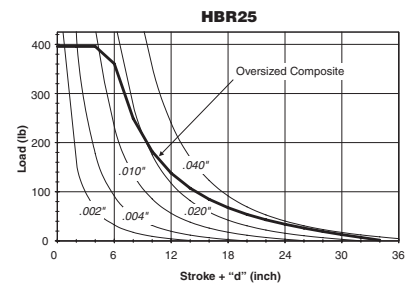
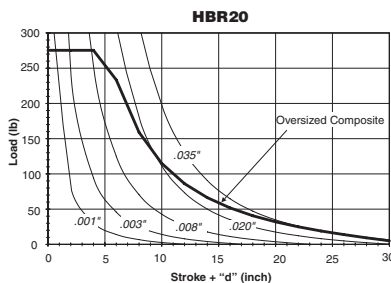
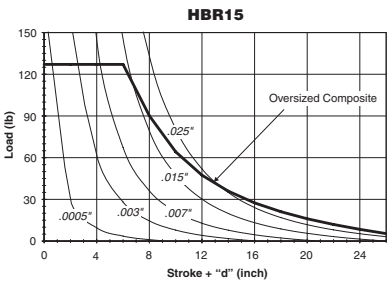
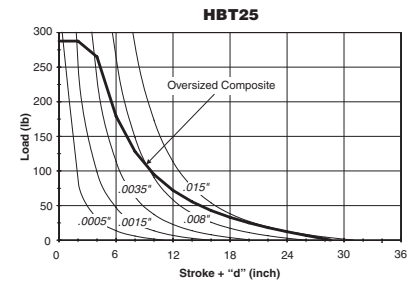
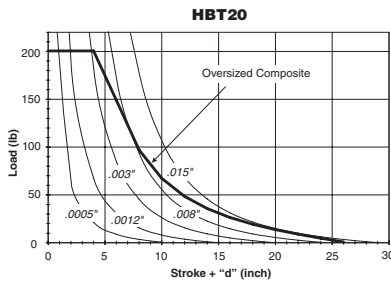
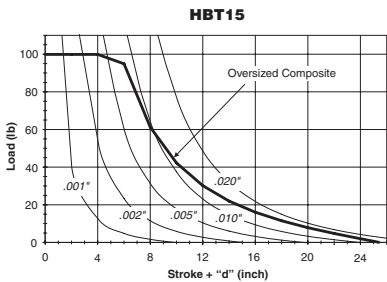
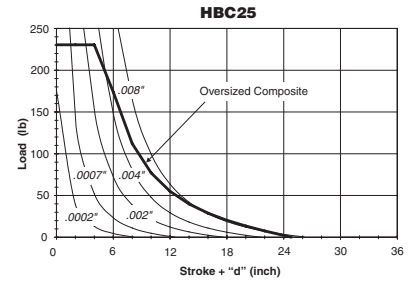
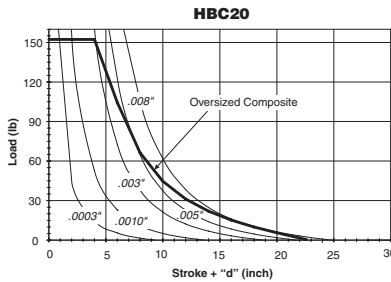
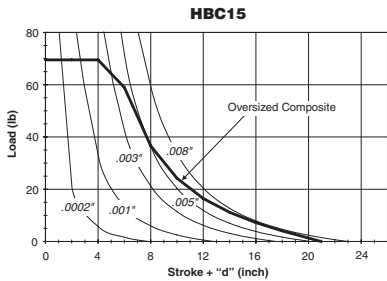
**Note:** Actuator life may vary depending on the severity of the following variables:

- Acceleration
- Velocity
- Vibration
- Orientation



**EXAMPLE:**  
 An HBT15 with oversized composite bushings and a "stroke+d" of 8" would have a load capacity of 60 lbs.

Guided Cylinders	PST Series	HBC15	HBC20	HBC25	
		P5L Series	HBT15	HBT20	HBT25
			HB Series	HBR15	HBR20
		P5E Series	XL Series	HBB15	HBB20



For inventory, lead times, and kit lookup, visit [www.pdnplu.com](http://www.pdnplu.com)

E76

**Parker Hannifin Corporation**  
 Pneumatic Division  
 Richland, Michigan  
[www.parker.com/pneumatics](http://www.parker.com/pneumatics)

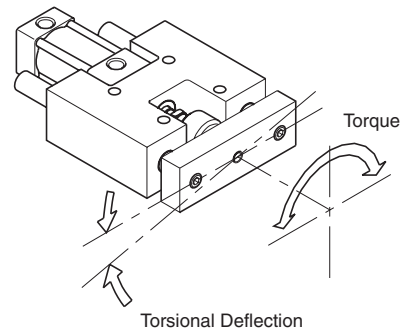


**Symmetrical Torque Capacity with Standard Shafting**

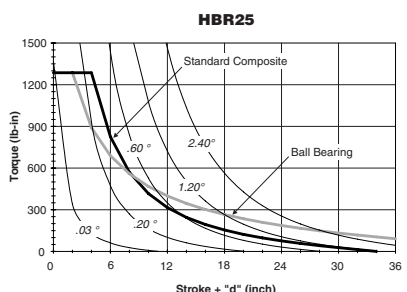
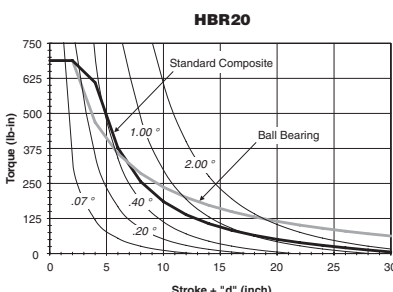
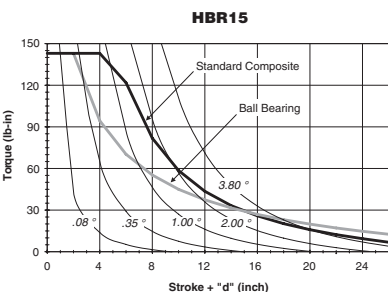
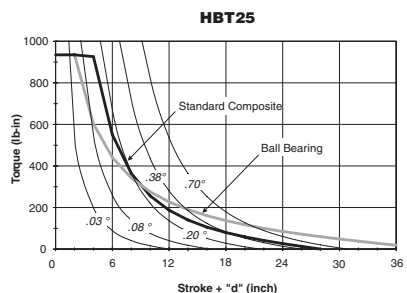
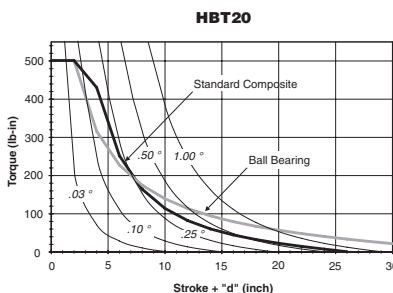
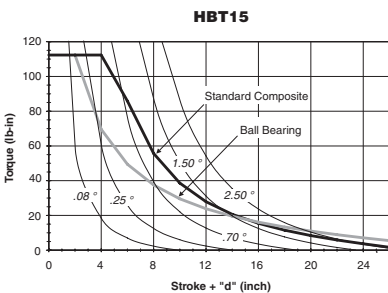
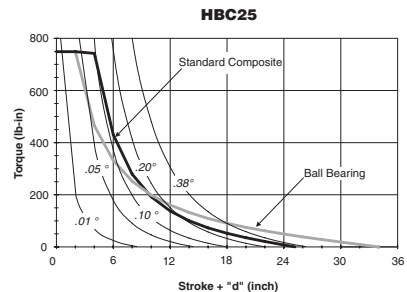
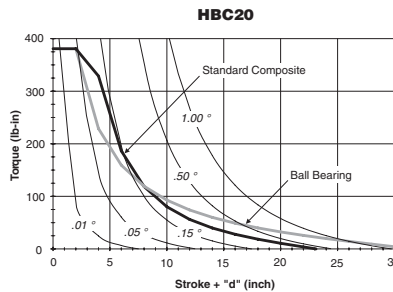
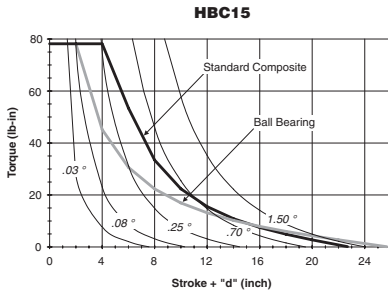
The plots on these two pages provide the torsional load vs. actuator stroke for various slide sizes. Torsional loads will cause a slight amount of angular deflection of the tooling plate. Angular deflection is also shown, which should be used in non-rotating applications. The data presented is based on a bearing life equivalent to 10 million cycles for dynamic conditions. Higher dynamic torques will reduce cycle life. For static torque, multiply the information in the graph by 1.5.

**Note:** Actuator life may vary depending on the severity of the following variables:

- Acceleration
- Velocity
- Vibration
- Orientation



**EXAMPLE:**  
 An HBT25 with composite bushings and a "stroke+d" of 12" would have a torque capacity of 200 lb-in.



<b>M</b>	Guided Cylinders
	P5T Series
	P5L Series
	HB Series
	P5E Series
	XL Series



For inventory, lead time, and kit lookup, visit [www.pdnplu.com](http://www.pdnplu.com)

E77

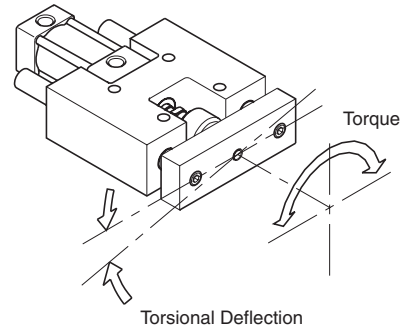
**Parker Hannifin Corporation**  
 Pneumatic Division  
 Richland, Michigan  
[www.parker.com/pneumatics](http://www.parker.com/pneumatics)

**Symmetrical Torque Capacity with Oversized Shafting**

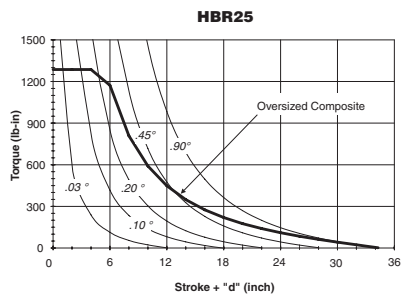
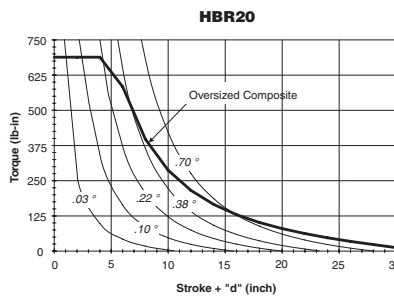
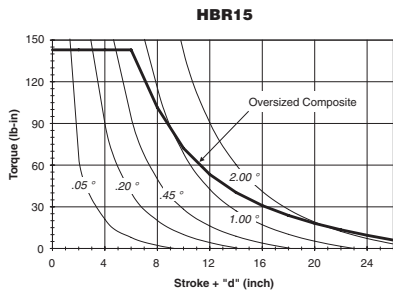
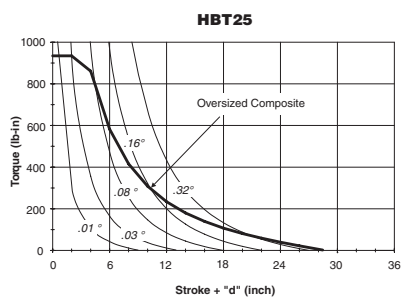
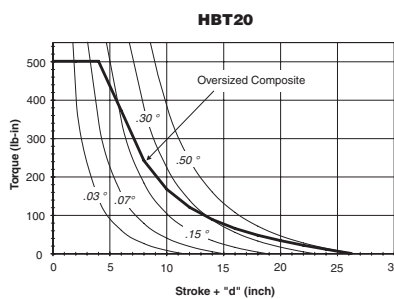
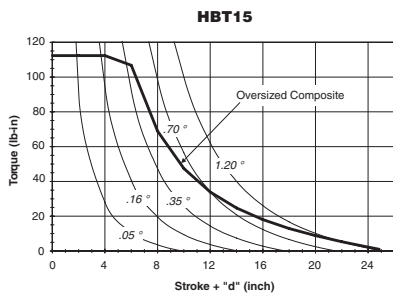
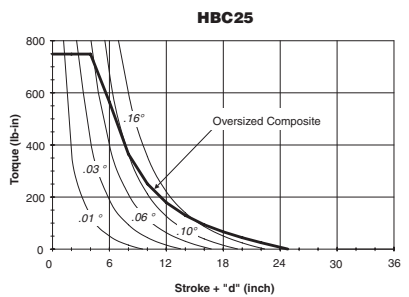
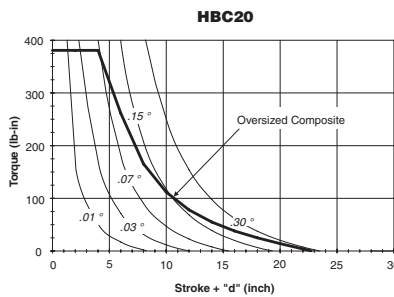
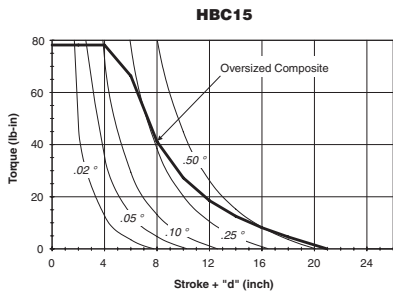
The plots on these two pages provide the torsional load vs. actuator stroke for various slide sizes. Torsional loads will cause a slight amount of angular deflection of the tooling plate. Angular deflection is also shown. The data presented is based on a bearing life equivalent to 10 million cycles for dynamic conditions. Higher dynamic torques will reduce cycle life. For static torque, multiply the information in the graph by 1.5.

**Note:** Actuator life may vary depending on the severity of the following variables:

- Acceleration
- Velocity
- Vibration
- Orientation



**EXAMPLE:**  
An HBT25 with oversized composite bushings and a "stroke+d" of 6" would have a torque capacity of 600 lb-in.



Guided Cylinders	P5T Series	P5L Series	HB Series	P5E Series	XL Series



For inventory, lead times, and kit lookup, visit [www.pdnplu.com](http://www.pdnplu.com)

E78

**Parker Hannifin Corporation**  
Pneumatic Division  
Richland, Michigan  
[www.parker.com/pneumatics](http://www.parker.com/pneumatics)

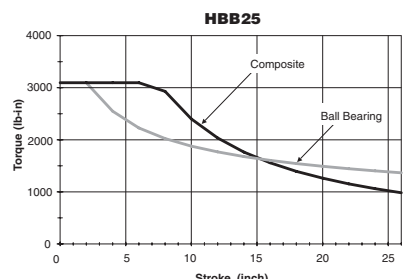
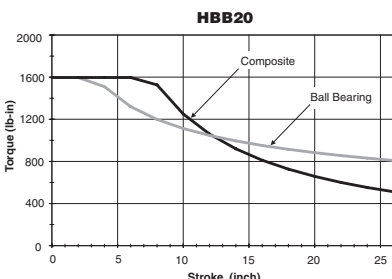
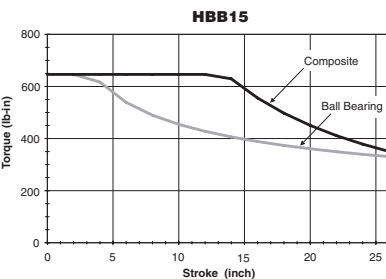
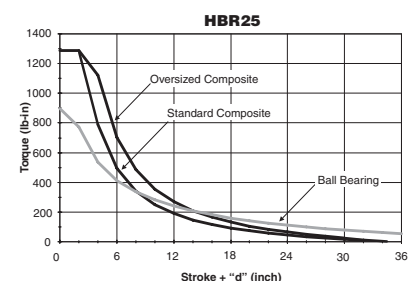
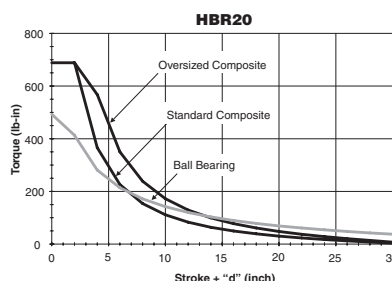
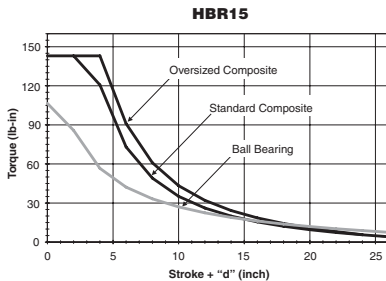
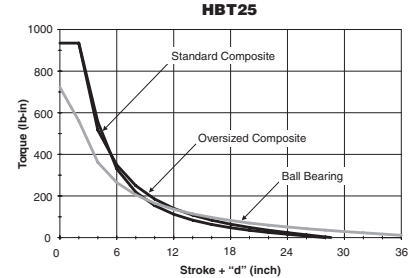
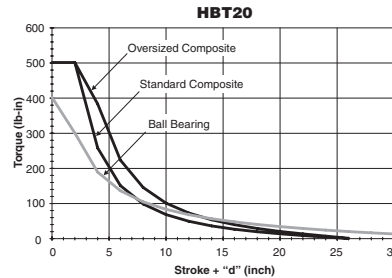
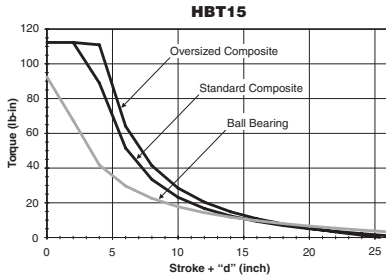
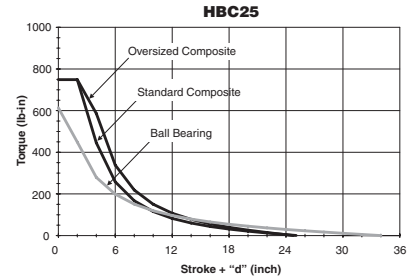
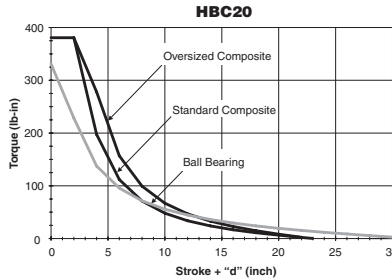
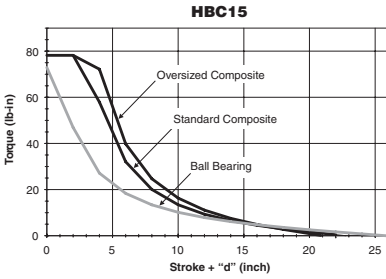
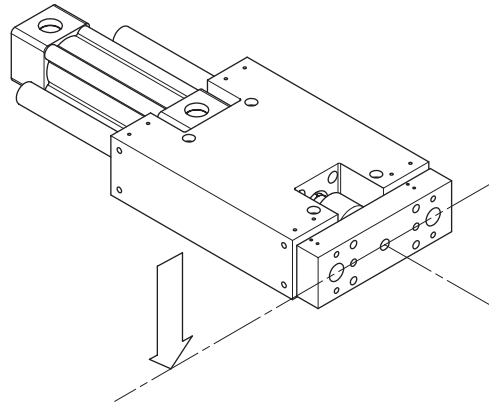
**Asymmetrical Torque Capacity**

Asymmetrical loading occurs when the load is applied to one side of the unit. HB Series units can resist torsional loads that are asymmetrical. The graphs show torsional load capacity for both standard and oversized shafting under dynamic conditions. For static applications, multiply the information in the graphs by 1.5.

**Note:** Actuator life may vary depending on the severity of the following variables:

- Acceleration
- Velocity
- Vibration
- Orientation

**Torsional Load**



<b>M</b>	Guided Cylinders
P5T Series	P5L Series
P5E Series	XL Series



For inventory, lead time, and kit lookup, visit [www.pdnplu.com](http://www.pdnplu.com)

E79

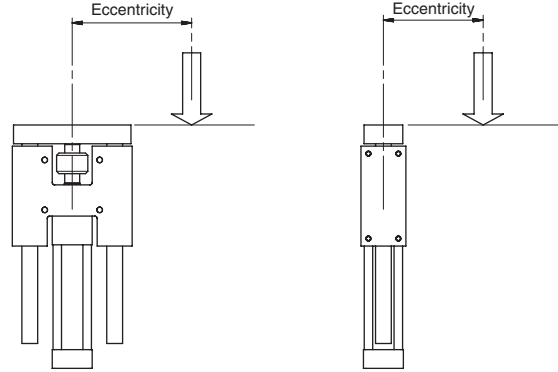
**Parker Hannifin Corporation**  
 Pneumatic Division  
 Richland, Michigan  
[www.parker.com/pneumatics](http://www.parker.com/pneumatics)

**Vertical Eccentric Load Capacity**

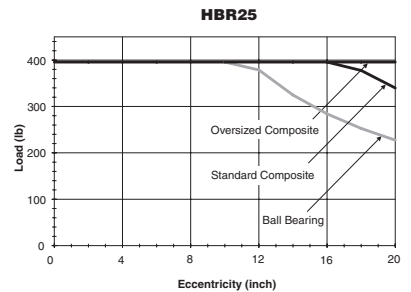
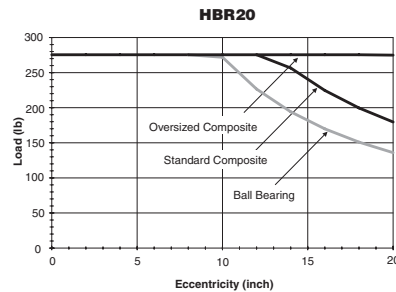
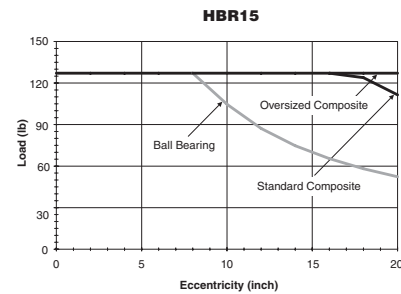
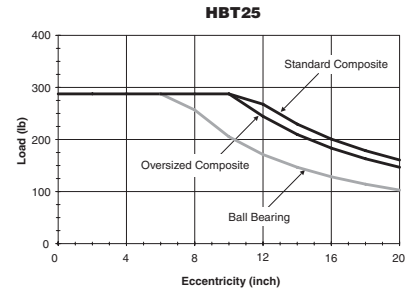
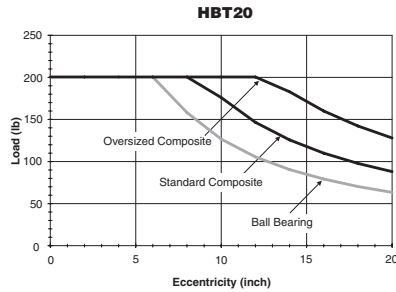
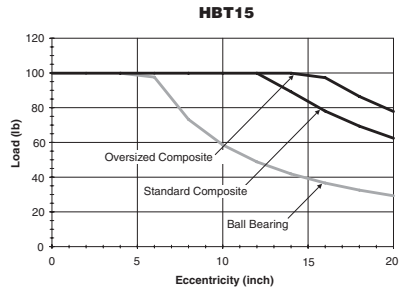
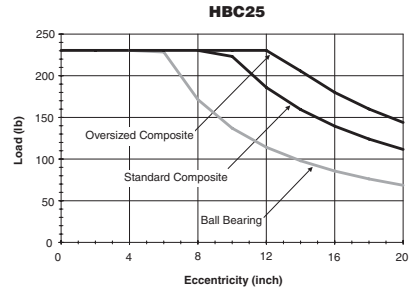
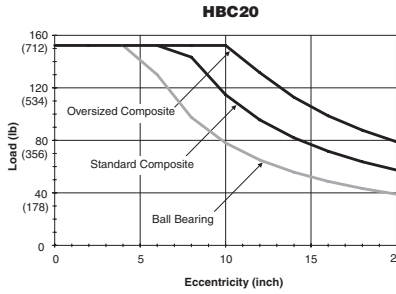
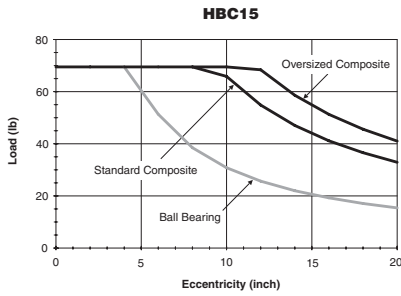
HB Series units mounted vertically will have the same eccentric load capacity regardless of orientation. The graphs provide maximum load capacity for an eccentric mounted load on a 4" stroke cylinder. The load is assumed to be mounted at the face of the tooling plate.

**Note:** Actuator life may vary depending on the severity of the following variables:

- Acceleration
- Velocity
- Vibration



**EXAMPLE:**  
 An HBT15 with ball bearings carrying an eccentric load with an eccentricity distance of 15" would have a load capacity of 40 lbs.



Guided Cylinders	P5T Series	P5L Series	HB Series	P5E Series	XL Series



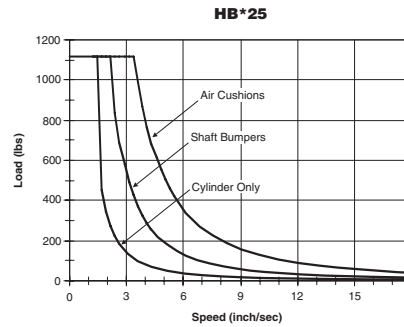
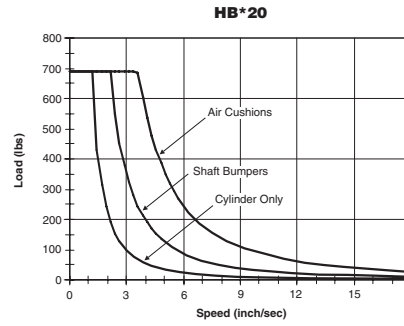
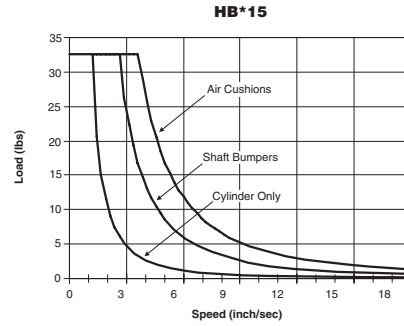
For inventory, lead times, and kit lookup, visit [www.pdnplu.com](http://www.pdnplu.com)

**Kinetic Energy**

These plots illustrate the stopping capacity of the HB Series with bumpers, cushions or cylinder only. This type of sizing is based on the weight of the load and the speed at which the load is moving. The bumper plots are based on a 0.020 deflection.

For values above the cushion line, shock absorbers must be specified. Follow the shock absorber sizing steps on the following page to ensure proper stopping capacity.

**Note:** These charts are to be used only to determine the stopping capacity of each guided cylinder.



<b>M</b>
Guided Cylinders
P5T Series
P5L Series
HB Series
P5E Series
XL Series



For inventory, lead time, and kit lookup, visit [www.pdnplu.com](http://www.pdnplu.com)

**Kinetic Energy**

Steps to sizing a guided cylinder with shocks:

- 1) Determine the "Moving Weight", W.  
 Use Table 1 to determine the "Kinetic Energy Weight" of a given slide. This value should be added to the weight of the load the slide will be carrying.  
 Moving Weight (lbs) =  
 Kinetic Energy Weight (lbs) + Weight of Load (lbs)
- 2) Determine the velocity of the load, V (ft/second)
- 3) Determine the cylinder force output at the operating pressure, F<sub>cylinder</sub> (lbs)
- 4) Determine the Kinetic Energy of the load:  
 KE = 0.2 × W × V<sup>2</sup> (lb-in)
- 5) Determine the Energy per Cycle, E<sub>cycle</sub> (lb-in):  
 E<sub>cycle</sub> = KE + F<sub>cylinder</sub> × Shock Stroke  
 (unless stroke adjusters are used, 1 inch is standard)  
*This value should be less than the value listed in table 2*
- 6) Determine the Energy per Hour: E<sub>hour</sub> (in-lbs)  
 E<sub>hour</sub> = 2 × E<sub>cycle</sub> × # of cycles in one hour  
 (a cycle is defined as the extension and retraction of the slide)  
*This value should be less than the value listed in table 2*
- 7) Determine the Effective Weight of the load  

$$W_{\text{effective}} = \frac{E_{\text{cycle}}}{0.2 \times V^2}$$
*This value should be between the values listed in table 2*

**Example:**

An HBT20-10D-B with standard support rods and shock absorbers will be carrying a load of 40 lbs at a velocity of 17 in/second (cycling 15 times per hour) while operating at 80 psi. Is this unit properly sized?

- 1) Moving Weight = [8.35 + (10 × 0.65)] + 40 lbs = 54.85 lbs
- 2) V = 17 in/second = 1.4 ft/second
- 3) F<sub>cylinder</sub> = 251 lbs
- 4) KE = 0.2 × 54.85 × 1.42 = 21.5 lb-in
- 5) E<sub>cycle</sub> = 21.5 + 251 = 272.5 lb-in
- 6) E<sub>hour</sub> = 2 × 272.5 × 15 = 8175 lb-in
- 7) 
$$W_{\text{effective}} = \frac{272.5}{0.2 \times (1.4)^2} = 695 \text{ lbs}$$

The shock will dissipate the energy of the load.


**Table 1**

Model	Base weight (lb)	Stroke adder (lb/inch)	Base weight, oversized (lb)	Stroke adder (lb/inch)
HBC15	3.66	0.36	4.36	0.52
HBC20	7.15	0.65	8.19	0.84
HBC25	12.73	1.04	14.19	1.27
HBT15	4.70	0.36	5.67	0.52
HBT20	8.35	0.65	9.67	0.84
HBT25	14.22	1.04	16.01	1.27
HBR15	5.52	0.36	6.96	0.52
HBR20	10.29	0.65	12.46	0.84
HBR25	17.63	1.04	20.66	1.27
HBB15*	7.93	0.09	7.93	0.09
HBB20*	13.94	0.22	13.94	0.22
HBB25*	25.03	0.42	25.03	0.42

\* Support rods do not move with the carriage, so kinetic energy is the same for standard and oversized rods.

**Table 2**

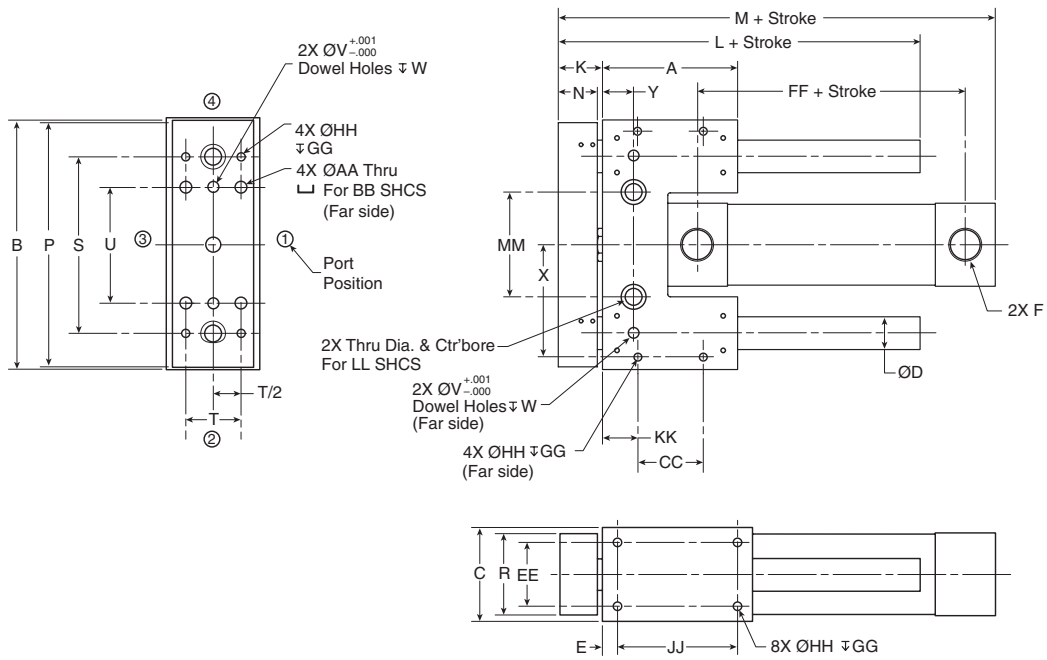
Size	Total energy per cycle (lb-in)	Total energy per hour (lb-in)	Effective weight (lb)	Velocity range (in/sec)
15	600	600,000	20 - 3000	6 - 144
20	900	800,000	30 - 4500	6 - 144
25	1500	670,000	28 - 3800	6 - 120


**Guided Cylinders**  
 P5T Series  
 P5L Series  
 HB Series  
 P5E Series  
 XL Series



For inventory, lead times, and kit lookup, visit [www.pdnplu.com](http://www.pdnplu.com)

**HBC Series**



Model number	A	B	C	Ds*	Do**	E	F NPTF	F BSPP	K	L	M	N	P	R	S	T	U
15	3.25	6.00	2.25	20mm (0.79)	25mm (0.98)	0.375	1/4 <sup>1</sup>	1/4	1.06	5.19	6.26	0.94	5.88	1.94	4.250	1.375	2.750
20	4.00	7.25	2.75	25mm (0.98)	30mm (1.18)	0.500	3/8	1/4	1.31	6.39	7.00	1.19	7.13	2.44	5.000	1.750	3.250
25	5.00	9.00	3.25	30mm (1.18)	35mm (1.38)	0.500	3/8	3/8	1.56	7.82	8.38	1.44	8.88	2.88	6.500	2.000	3.750

Model number	V	W	X	Y	AA	BB	CC	EE	FF	GG	HH	JJ	KK	LL	MM
15	0.251	0.27	2.750	0.750	0.28	1/4	1.750	1.500	2.31	0.50	1/4-20	2.50	0.75	3/8	2.500
20	0.313	0.33	3.250	0.750	0.34	5/16	2.250	1.750	2.31	0.63	5/16-18	3.00	0.88	3/8	3.000
25	0.376	0.39	4.000	1.532	0.41	3/8	3.000	2.250	2.38	0.75	3/8-16	4.00	1.00	1/2	4.000

\* Standard shafting  
\*\* Oversized shafting

All dimensions in inches unless otherwise noted.



Guided  
Cylinders

P5T  
Series

P5L  
Series

HB  
Series

P5E  
Series

XL  
Series

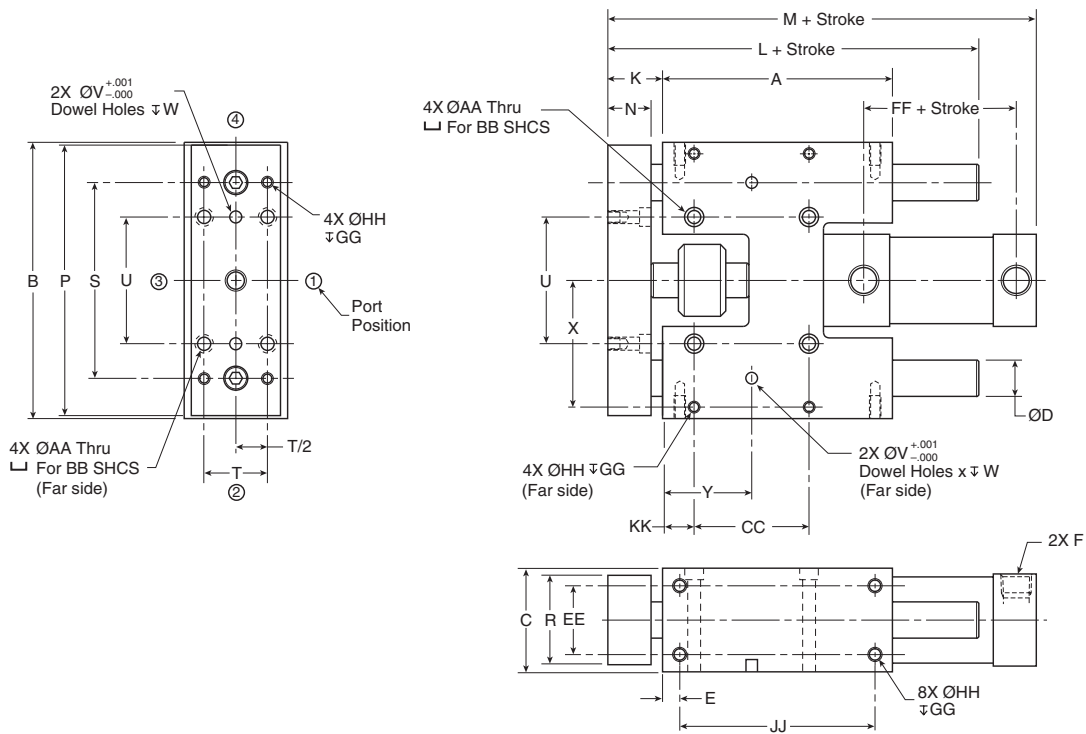


For inventory, lead time, and kit lookup, visit [www.pdnplu.com](http://www.pdnplu.com)

E83

**Parker Hannifin Corporation**  
Pneumatic Division  
Richland, Michigan  
[www.parker.com/pneumatics](http://www.parker.com/pneumatics)

**HBT Series**



Model number	A	B	C	Ds*	Do**	E	F NPTF	F BSSP	K	L	M	N	P	R	S	T
15	5.0	6.00	2.25	20mm (0.79)	25mm (0.98)	0.375	1/4 1	1/4	1.06	6.94	8.19	0.94	5.88	1.94	4.250	1.375
20	5.5	7.25	2.75	25mm (0.98)	30mm (1.18)	0.500	3/8	1/4	1.31	7.88	8.94	1.19	7.13	2.44	5.000	1.750
25	6.5	9.00	3.25	30mm (1.18)	35mm (1.38)	0.500	3/8	3/8	1.56	9.31	10.31	1.44	8.88	2.88	6.500	2.000

Model number	U	V	W	X	Y	AA	BB	CC	EE	FF	GG	HH	JJ	KK
15	2.750	0.251	0.27	2.750	1.938	0.28	1/4	2.500	1.500	2.31	0.50	1/4-20	4.25	0.69
20	3.250	0.313	0.33	3.250	2.250	0.34	5/16	2.750	1.750	2.31	0.63	5/16-18	4.50	0.88
25	3.750	0.376	0.39	4.000	2.750	0.41	3/8	3.500	2.250	2.38	0.75	3/8-16	5.50	1.00

\* Standard shafting  
 \*\* Oversized shafting

All dimensions in inches unless otherwise noted.

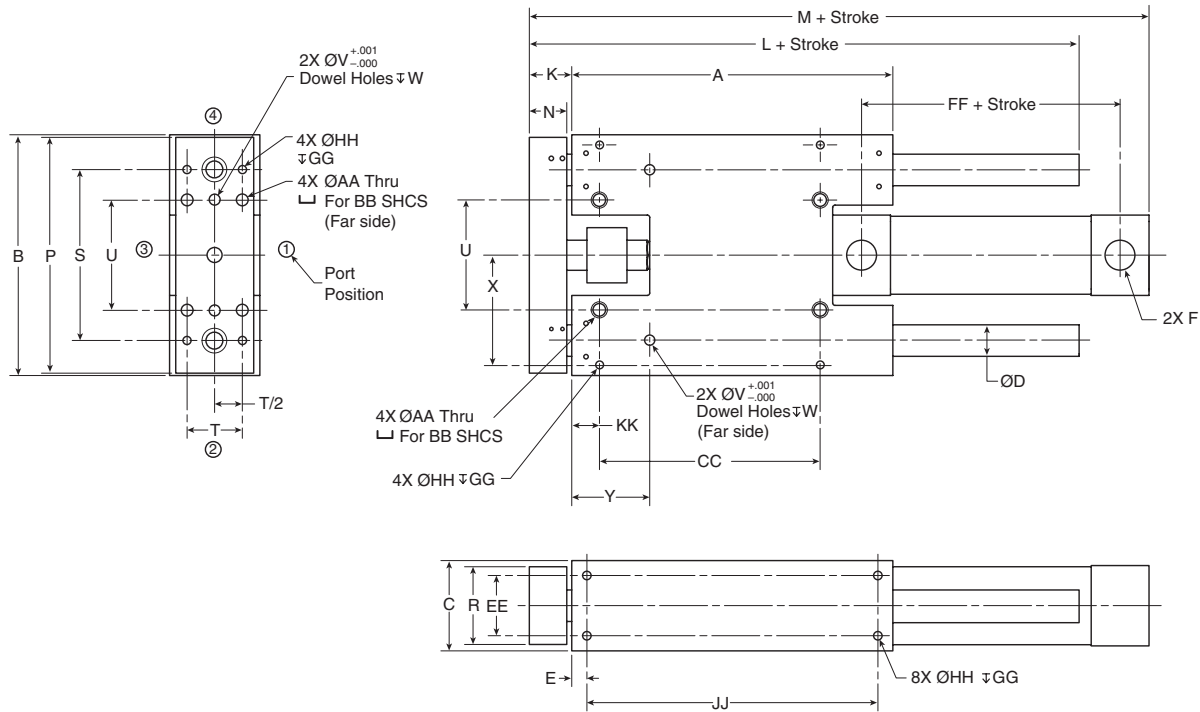
**Parker**  
 Guided Cylinders  
 Series P5T  
 Series P5L  
 Series HB  
 Series P5E  
 Series XL



For inventory, lead times, and kit lookup, visit [www.pdnplu.com](http://www.pdnplu.com)



**HBR Series**



Model number	A	B	C	Ds*	Do**	E	F NPTF	F BSPP	K	L	M	N	P	R	S	T
15	8.00	6.00	2.25	20mm (0.79)	25mm (0.98)	0.375	1/4 1	1/4	1.06	9.94	11.19	0.94	5.88	1.94	4.250	1.375
20	10.00	7.25	2.75	25mm (0.98)	30mm (1.18)	0.500	3/8	1/4	1.31	12.39	13.44	1.19	7.13	2.44	5.000	1.750
25	12.00	9.00	3.25	30mm (1.18)	35mm (1.38)	0.500	3/8	3/8	1.56	14.82	15.82	1.44	8.88	2.88	6.500	2.000

Model number	U	V	W	X	Y	AA	BB	CC	EE	FF	GG	HH	JJ	KK
15	2.750	0.251	0.27	2.750	1.938	0.28	1/4	5.500	1.500	2.31	0.50	1/4-20	7.25	0.69
20	3.250	0.313	0.33	3.250	2.250	0.34	5/16	7.250	1.750	2.31	0.63	5/16-18	9.00	0.88
25	3.750	0.376	0.39	4.000	2.760	0.41	3/8	9.000	2.250	2.38	0.75	3/8-16	11.00	1.00

\* Standard shafting  
\*\* Oversized shafting

All dimensions in inches unless otherwise noted.

**P**

Guided Cylinders

P5T Series

P5L Series

HB Series

P5E Series

XL Series

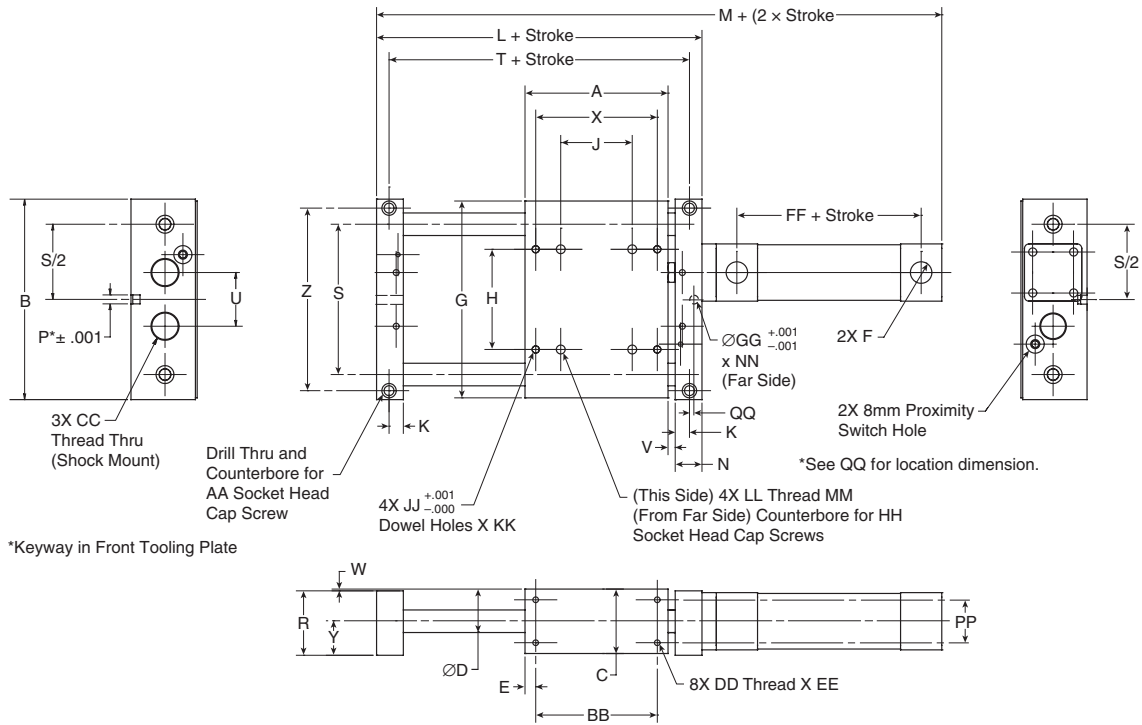


For inventory, lead time, and kit lookup, visit [www.pdnplu.com](http://www.pdnplu.com)

E85

**Parker Hannifin Corporation**  
Pneumatic Division  
Richland, Michigan  
[www.parker.com/pneumatics](http://www.parker.com/pneumatics)

**HBB Series**



Model	A	B	C	Ds*	Do**	E	F NPTF	F BSPP	G	H	J	K	L	M
15	5.00	7.00	2.25	20mm (0.79)	25mm (0.98)	0.375	1/4	1/4	6.875	3.50	2.50	0.50	7.00	11.13
20	5.50	8.75	2.75	25mm (0.98)	30mm (1.18)	0.500	3/8	1/4	8.625	4.50	2.50	0.50	8.00	12.13
25	6.50	11.00	3.25	30mm (1.18)	35mm (1.38)	0.500	3/8	3/8	10.875	6.00	3.00	0.50	9.50	13.75

Model	N	P	R	S	T	U	V	W	X	Y	Z	AA	BB
15	0.94	0.313	2.25	5.25	6.13	1.88	0.13	0.06	4.25	1.188	6.375	5/16-18	4.25
20	1.19	0.313	2.75	6.50	6.63	2.25	0.13	0.06	4.25	1.438	8.000	3/8-16	4.50
25	1.44	0.313	3.25	8.50	7.63	3.50	0.13	0.06	5.00	1.688	10.000	1/2-13	5.50

Model	CC	DD	EE	FF	GG	HH	JJ	KK	LL	MM	NN	PP	QQ
15	25mm	1/4-20	0.50	2.31	0.313	5/16-18	0.251	0.27	3/8-16	0.75	0.25	1.50	0.500
20	25mm	5/16-18	0.63	2.31	0.313	5/16-18	0.251	0.27	3/8-16	0.75	0.25	1.75	0.594
25	1 1/4-12	3/8-16	0.75	2.38	0.313	5/16-18	0.313	0.33	3/8-16	0.75	0.25	2.75	0.719

\* Standard shafting  
\*\* Oversized shafting

All dimensions in inches unless otherwise noted.



For inventory, lead times, and kit lookup, visit [www.pdnplu.com](http://www.pdnplu.com)

E86

**Parker Hannifin Corporation**  
Pneumatic Division  
Richland, Michigan  
[www.parker.com/pneumatics](http://www.parker.com/pneumatics)

## Options

## Guided Pneumatic Cylinders HBC, HBT, HBR Series

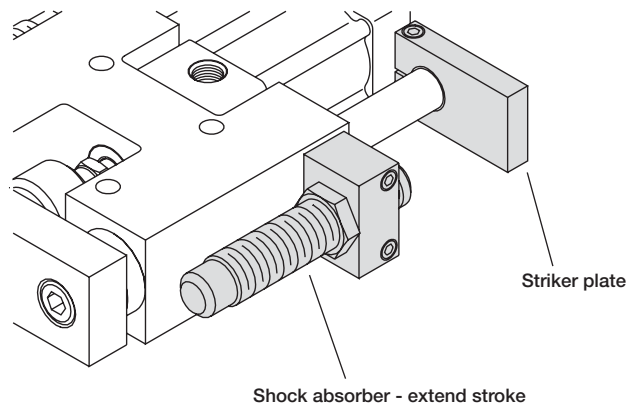
### Shock Absorbers/Stroke Adjusters (A, A1, A2)

Adjustable shock absorbers are provided when this option is specified. These dissipate kinetic energy over a wide range of velocities and weights. Cylinder stroke is adjusted by moving the shock striker plate.

#### Shock Absorber Adjustment Procedure:

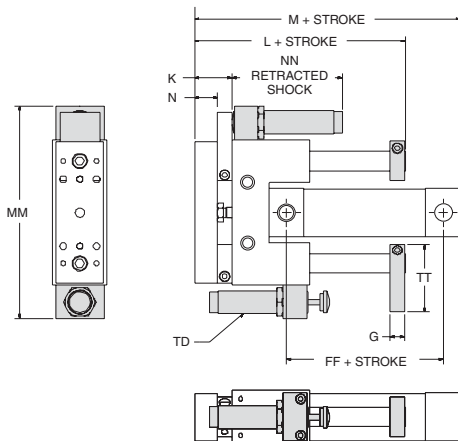
Proper adjustment is important to maximize a shock absorber's performance. With a range of zero to ten, shocks are factory preset at five. Cycle the slide to impact the shock absorber. Rotate the shock's adjustment knob to achieve smooth deceleration. Adjusting towards zero increases resistance.

If the initial impact is too hard, rotate the knob towards ten to lessen the resistance. If the final setting is less than one, a larger shock and/or slide should be considered. Tighten the adjusting knob set screw to maintain resistance



### Shock Absorbers/Stroke Adjusters Extend and Retract (A)

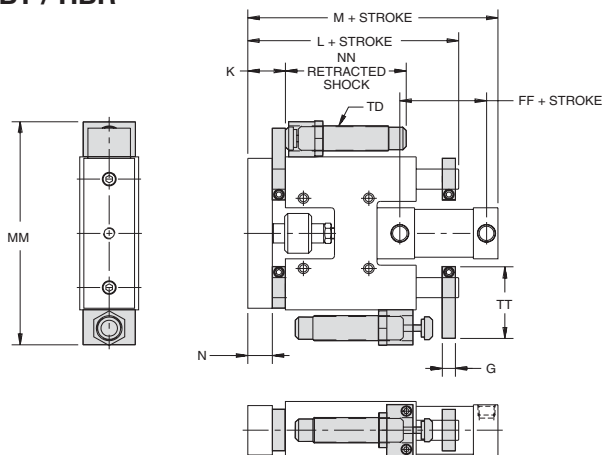
#### HBC



Model	G	K	L	M	N
HBC15	0.50	1.53	5.66	6.97	0.94
HBC20	0.63	1.88	6.95	7.82	1.19
HBC25	0.75	2.31	8.57	9.38	1.44

Model	FF	MM	NN	TD	TT
HBC15	2.56	8.75	4.62	M25 x 1.5	2.81
HBC20	2.56	10.00	5.86	M25 x 1.5	3.25
HBC25	2.63	12.50	4.45	1 1/4 - 12	4.13

#### HBT / HBR



Model	G	K	L	M	N
HBT15	0.50	1.53	7.31	8.81	0.94
HBT20	0.63	1.88	8.44	9.75	1.19
HBT25	0.75	2.31	10.06	11.31	1.44

Model	FF	MM	NN	TD	TT
HBT15	2.56	8.75	4.62	M25 x 1.5	2.81
HBT20	2.56	10.00	5.86	M25 x 1.5	3.25
HBT25	2.63	12.50	4.45	1 1/4 - 12	4.13

Model	G	K	L	M	N
HBR15	0.50	1.53	10.41	11.90	0.94
HBR20	0.63	1.88	12.95	14.26	1.19
HBR25	0.75	2.31	15.57	16.82	1.44

Model	FF	MM	NN	TD	TT
HBR15	2.56	8.75	4.62	M25 x 1.5	2.81
HBR20	2.56	10.00	5.86	M25 x 1.5	3.25
HBR25	2.63	12.50	4.45	1 1/4 - 12	4.13

All dimensions shown in inches.



For inventory, lead time, and kit lookup, visit [www.pdnplu.com](http://www.pdnplu.com)



Guided  
Cylinders

P5T  
Series

P5L  
Series

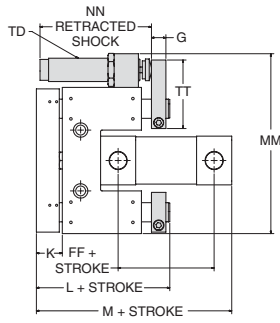
HB  
Series

P5E  
Series

XL  
Series

Shock Absorbers Extend Only (A1)

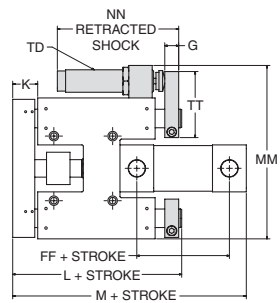
HBC



Model	G	K	L	M	N
HBC15	0.50	1.06	5.19	6.38	0.94
HBC20	0.63	1.31	6.39	7.13	1.19
HBC25	0.75	1.56	7.82	8.50	1.44

Model	FF	MM	NN	TD	TT
HBC15	2.44	7.38	4.62	M25 x 1.5	2.81
HBC20	2.44	8.63	5.86	M25 x 1.5	3.25
HBC25	2.50	10.75	4.45	1 1/4 - 12	4.13

HBT / HBR



Model	G	K	L	M	N
HBT15	0.50	1.06	6.94	8.32	0.94
HBT20	0.63	1.31	7.88	9.07	1.19
HBT25	0.75	1.56	9.31	10.44	1.44

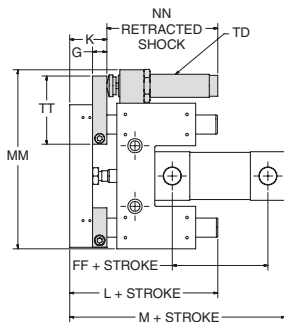
Model	FF	MM	NN	TD	TT
HBT15	2.44	7.38	4.62	M25 x 1.5	2.81
HBT20	2.44	8.63	5.86	M25 x 1.5	3.25
HBT25	2.50	10.75	4.45	1 1/4 - 12	4.13

Model	G	K	L	M	N
HBR15	0.50	1.06	9.94	11.31	0.94
HBR20	0.63	1.31	12.39	13.57	1.19
HBR25	0.75	1.56	14.82	15.94	1.44

Model	FF	MM	NN	TD	TT
HBR15	2.44	7.38	4.62	M25 x 1.5	2.81
HBR20	2.44	8.63	5.86	M25 x 1.5	3.25
HBR25	2.50	10.75	4.45	1 1/4 - 12	4.13

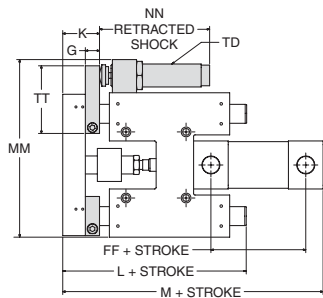
Shock Absorbers Retract Only (A2)

HBC



Model	K	L	M	FF	G	MM	NN	TD	TT
HBC15	1.53	5.66	6.85	2.44	0.50	7.38	4.62	M25 x 1.5	2.81
HBC20	1.88	6.95	7.69	2.44	0.63	8.63	5.86	M25 x 1.5	3.25
HBC25	2.32	8.57	9.26	2.50	0.75	10.75	4.45	1 1/4-12	4.13

HBT / HBR



Model	K	L	M	FF	G	MM	NN	TD	TT
HBT15	1.53	7.41	8.78	2.44	0.50	7.38	4.62	M25 x 1.5	2.81
HBT20	1.88	8.45	9.63	2.44	0.63	8.63	5.86	M25 x 1.5	3.25
HBT25	2.32	10.07	11.20	2.50	0.75	10.75	4.45	1 1/4-12	4.13

Model	K	L	M	FF	G	MM	NN	TD	TT
HBR15	1.53	10.40	11.78	2.44	0.50	7.38	4.62	M25 x 1.5	2.81
HBR20	1.88	12.95	14.13	2.44	0.63	8.63	5.86	M25 x 1.5	3.25
HBR25	2.32	15.57	16.70	2.50	0.75	10.75	4.45	1 1/4-12	4.13

All dimensions shown in inches.

**Guided Cylinders**  
 P5T Series  
 P5L Series  
 HB Series  
 P5E Series  
 XL Series



For inventory, lead times, and kit lookup, visit [www.pdnplu.com](http://www.pdnplu.com)

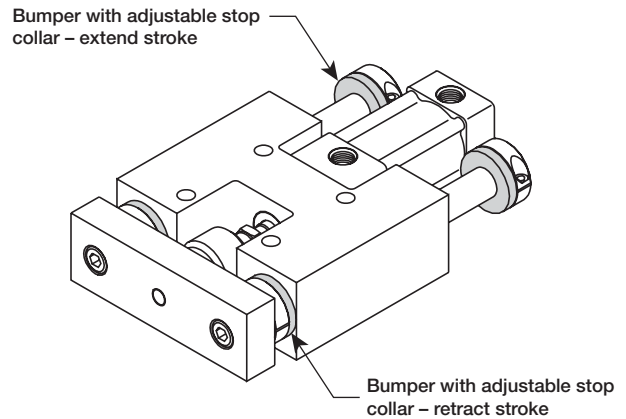
Options

Bumpers/Adjustable Stop Collars (B, B1, B2, B3, B4)

Bumpers absorb shock, reduce noise and permit faster cycle times thereby increasing production rates. They can be placed on the extend, retract or both positions.

When bumpers are specified, an adjustable stop collar is supplied on the extend stroke as standard. An extend stop collar provides travel adjustment. A stop collar can also be specified for the retract stroke. This stop collar is optional and is only provided if requested.

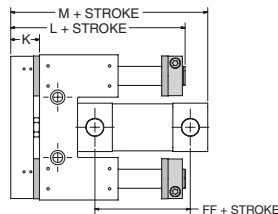
**Note:** Stop collars must be adjusted evenly to avoid creating a moment between the guide rods.



HBT shown with B4 option

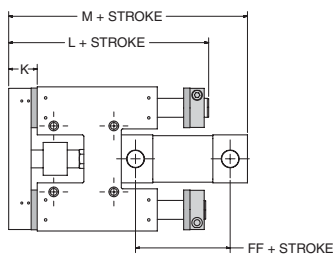
Bumpers Both Ends (B)

HBC



Model	K	L	M	FF
HBC15	1.19	5.32	6.62	2.56
HBC20	1.44	6.51	7.38	2.56
HBC25	1.69	7.94	8.75	2.63

HBT / HBR



Model	K	L	M	FF
HBT15	1.19	7.07	8.56	2.56
HBT20	1.44	8.01	9.32	2.56
HBT25	1.69	9.44	10.69	2.63

Model	K	L	M	FF
HBR15	1.19	10.07	11.56	2.56
HBR20	1.44	12.51	13.82	2.56
HBR25	1.69	14.94	16.19	2.63

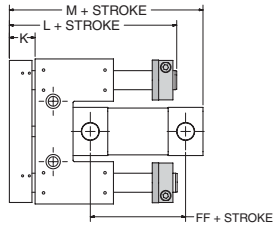
All dimensions shown in inches.



For inventory, lead time, and kit lookup, visit [www.pdnplu.com](http://www.pdnplu.com)

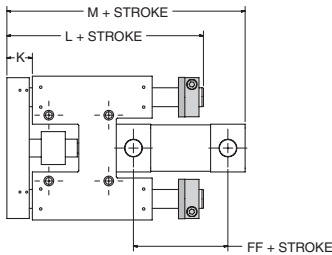
Bumpers and Adjustable Stop Collars, Extend Only (B1)

HBC



Model	K	L	M	FF
HBC15	1.06	5.19	6.37	2.44
HBC20	1.31	6.39	7.13	2.44
HBC25	1.56	7.82	8.50	2.50

HBT / HBR

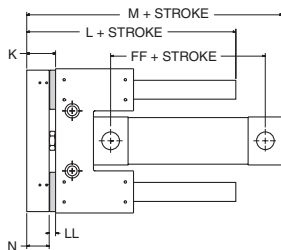


Model	K	L	M	FF
HBT15	1.06	6.94	8.31	2.44
HBT20	1.31	7.89	9.07	2.44
HBT25	1.56	9.32	10.44	2.50

Model	K	L	M	FF
HBR15	1.06	9.94	11.31	2.44
HBR20	1.31	12.39	13.57	2.44
HBR25	1.56	14.82	15.94	2.50

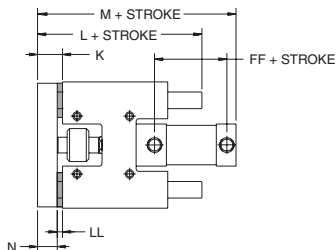
Bumpers on Retract Only (B2)

HBC



Model	K	L	M	N	FF	LL
HBC15	1.19	5.32	6.51	0.94	2.44	0.25
HBC20	1.44	6.51	7.26	1.19	2.44	0.25
HBC25	1.69	7.94	8.63	1.44	2.50	0.25

HBT / HBR



Model	K	L	M	N	FF	LL
HBT15	1.19	7.07	8.44	0.94	2.44	0.25
HBT20	1.44	8.01	9.19	1.19	2.44	0.25
HBT25	1.69	9.44	10.57	1.44	2.50	0.25

Model	K	L	M	N	FF	LL
HBR15	1.19	10.07	11.44	0.94	2.44	0.25
HBR20	1.44	12.51	13.70	1.19	2.44	0.25
HBR25	1.69	14.94	16.07	1.44	2.50	0.25

All dimensions shown in inches.



For inventory, lead times, and kit lookup, visit [www.pdnplu.com](http://www.pdnplu.com)

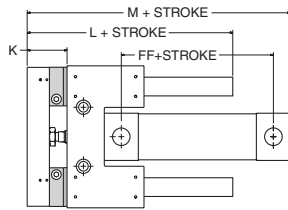
E90

**Parker Hannifin Corporation**  
Pneumatic Division  
Richland, Michigan  
[www.parker.com/pneumatics](http://www.parker.com/pneumatics)

Guided Cylinders  
 Series P5T  
 Series P5L  
 Series HB  
 Series P5E  
 Series XL

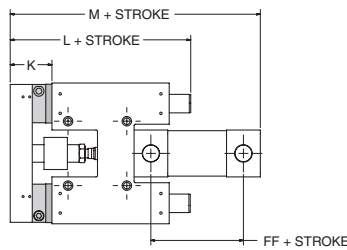
Bumpers and Adjustable Stop Collars, Retract Only (B3)

HBC



Model	K	L	M	FF
HBC15	1.78	5.91	7.10	2.44
HBC20	2.03	7.10	7.84	2.44
HBC25	2.28	8.53	9.22	2.50

HBT / HBR

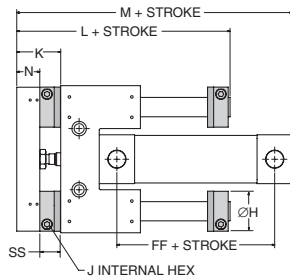


Model	K	L	M	FF
HBT15	1.78	7.66	9.03	2.44
HBT20	2.03	8.60	9.78	2.44
HBT25	2.28	10.03	11.16	2.50

Model	K	L	M	FF
HBR15	1.78	10.66	12.03	2.44
HBR20	2.03	13.10	14.28	2.44
HBR25	2.28	15.53	16.66	2.50

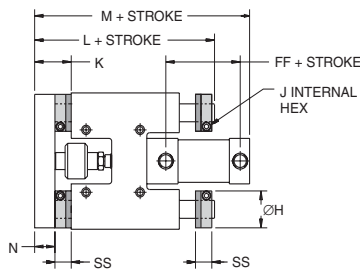
Bumpers and Adjustable Stop Collars, Both Ends (B4)

HBC



Model	H(s)*	H(o)**	J	K	L	M	N	FF	SS
HBC15	1.57	1.77	3/16	1.78	5.91	7.22	0.94	2.56	0.84
HBC20	1.77	2.12	3/16	2.03	7.10	7.97	1.19	2.56	0.84
HBC25	2.12	2.23	3/16	2.28	8.53	9.34	1.44	2.63	0.84

HBT / HBR



Model	H(s)*	H(o)**	J	K	L	M	N	FF	SS
HBT15	1.57	1.77	3/16	1.78	7.56	9.06	0.94	2.56	0.84
HBT20	1.77	2.12	3/16	2.03	8.69	10.00	1.19	2.56	0.84
HBT25	2.12	2.23	3/16	2.28	10.31	11.56	1.44	2.63	0.84

Model	H(s)*	H(o)**	J	K	L	M	N	FF	SS
HBR15	1.57	1.77	3/16	1.78	10.66	12.15	0.94	2.56	0.84
HBR20	1.77	2.12	3/16	2.03	13.10	14.41	1.19	2.56	0.84
HBR25	2.12	2.23	3/16	2.28	15.53	16.78	1.44	2.63	0.84

All dimensions shown in inches.



For inventory, lead time, and kit lookup, visit [www.pdnplu.com](http://www.pdnplu.com)

**Options**

**Shock Absorbers**

Adjustable shock absorbers are provided when this option is specified. These dissipate kinetic energy over a wide range of velocities and weights. Cylinder stroke is adjusted by moving the threaded stroke adjuster. It is important to adjust the threaded stroke adjuster to prevent the shock from "bottoming". Maximum adjustment is 1/2".

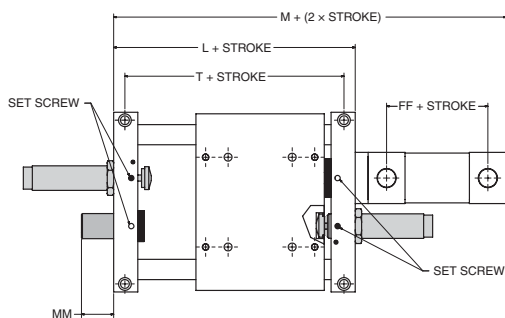
Shock Absorber Adjustment Procedure: Proper adjustment is important to maximize a shock absorber's performance. With a range of zero to ten, shocks are factory pre-set at five. Cycle the slide to impact the shock absorber. Rotate the shock's adjustment knob to achieve smooth deceleration. Adjusting towards zero increases resistance.

If the initial impact is too hard, rotate the knob towards ten to lessen the resistance. If the final setting is less than one, a larger shock and/or slide should be considered. Tighten the adjusting knob set screw to maintain resistance.


**Note:** A standard HBB unit includes mounting holes in the end plates to allow field installation of the shock absorbers.

**Shock Absorbers (A, A1, A2)**

**HBB**



Model	L	T	M	FF	MM
HBB15	7.38	6.50	11.75	2.56	1.25
HBB20	8.38	7.00	12.75	2.56	1.00
HBB25	9.88	8.00	14.38	2.63	1.00

  
 Guided Cylinders  
 Series P5T  
 Series P5L  
 Series HB  
 Series P5E  
 Series XL

All dimensions shown in inches.



For inventory, lead times, and kit lookup, visit [www.pdnplu.com](http://www.pdnplu.com)



Options

Bumpers/Adjustable Stop Collars (B, B1, B2, B3, B4, B5)

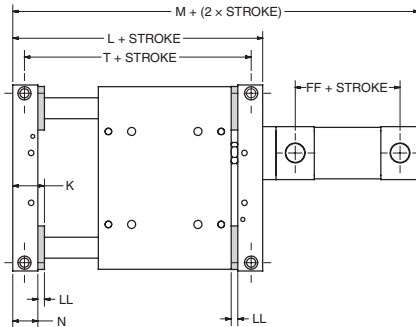
Bumpers absorb shock, reduce noise and permit faster cycle times thereby increasing production rates. They can be placed on the extend, retract or both positions.

**Note:** Stop collars must be adjusted evenly to avoid creating a moment between the guide rods.

A stop collar can be provided for travel adjustment. This stop collar is optional and is only provided if requested.

Bumpers Both Ends (B)

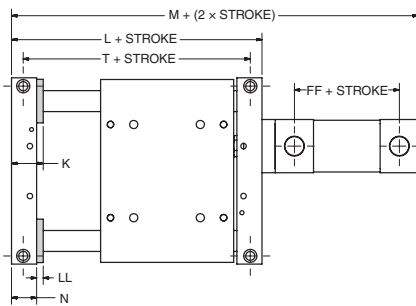
HBB



Model	L	T	M	K	N	FF	LL
HBB15	7.375	6.50	11.75	1.19	0.94	2.56	0.25
HBB20	8.375	7.00	12.75	1.44	1.19	2.56	0.25
HBB25	9.875	8.00	14.38	1.69	1.44	2.63	0.25

Bumpers, Extend Only (B1)

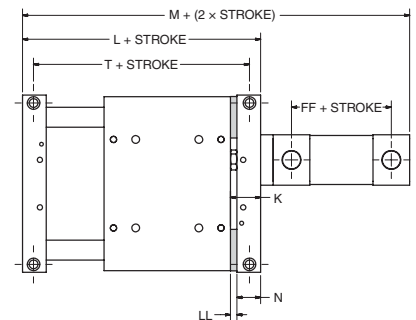
HBB



Model	L	T	M	K	N	FF	LL
HBB15	7.25	6.38	11.50	1.19	0.94	2.44	0.25
HBB20	8.25	6.88	12.50	1.44	1.19	2.44	0.25
HBB25	9.75	7.88	14.13	1.69	1.44	2.51	0.25

Bumpers on Retract Only (B2)

HBB



Model	L	T	M	K	N	FF	LL
HBB15	7.13	6.25	11.38	1.19	0.94	2.44	0.25
HBB20	8.13	6.75	12.38	1.44	1.19	2.44	0.25
HBB25	9.63	7.75	14.00	1.69	1.44	2.51	0.25

All dimensions shown in inches.



For inventory, lead time, and kit lookup, visit [www.pdnplu.com](http://www.pdnplu.com)



Guided  
Cylinders

P5T  
Series

P5L  
Series

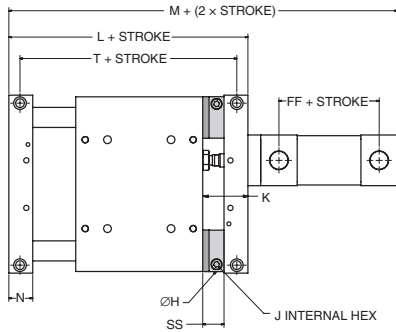
HB  
Series

P5E  
Series

XL  
Series

**Bumpers and Adjustable Stop Collars, Retract Only (B3)**

HBB

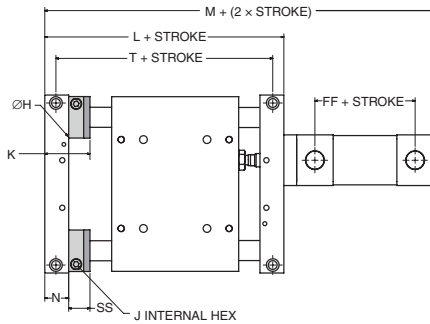


Model	L	T	M	K	N
HBB15	7.72	6.84	11.98	1.78	0.94
HBB20	8.72	7.34	12.98	2.03	1.19
HBB25	10.22	8.34	14.60	2.28	1.44

Model	H(s)*	H(o)**	J	FF	SS
HBB15	1.57	1.77	3/16	2.44	0.84
HBB20	1.77	2.12	3/16	2.44	0.84
HBB25	2.12	2.23	3/16	2.50	0.84

**Bumpers and Adjustable Stop Collars, Extend Only (B4)**

HBB

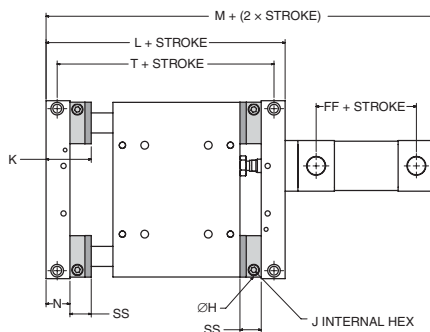


Model	L	T	M	K	N
HBB15	7.85	6.97	12.10	1.78	0.94
HBB20	8.85	7.47	13.10	2.03	1.19
HBB25	10.35	8.47	14.73	2.28	1.44

Model	H(s)*	H(o)**	J	FF	SS
HBB15	1.57	1.77	3/16	2.44	0.84
HBB20	1.77	2.12	3/16	2.44	0.84
HBB25	2.12	2.23	3/16	2.50	0.84

**Bumpers and Adjustable Stop Collars, Both Ends (B5)**

HBB



Model	L	T	M	K	N
HBB15	8.56	7.68	12.93	1.78	0.94
HBB20	9.56	8.18	13.93	2.03	1.19
HBB25	11.06	9.18	15.56	2.28	1.44

Model	H(s)*	H(o)**	J	FF	SS
HBB15	1.57	1.77	3/16	2.56	0.84
HBB20	1.77	2.12	3/16	2.56	0.84
HBB25	2.12	2.23	3/16	2.63	0.84

\* Standard support rods  
\*\* Oversized support rods

All dimensions shown in inches.



For inventory, lead times, and kit lookup, visit [www.pdnplu.com](http://www.pdnplu.com)

Options

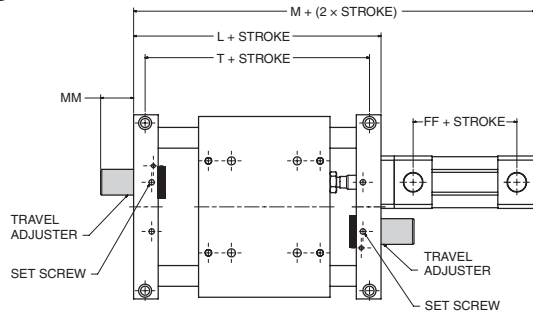
Threaded Stroke Adjusters (E, E1, E2, E3)

The threaded stroke adjust option allows for precise end of stroke positioning. The maximum stroke adjustment is one inch (1"). Threaded stroke adjusters are standard with shock absorbers.

**Note:** Not available with Bumper Options B, B1, B2, B3, B4.

Threaded Stroke Adjusters, Both Ends (E)

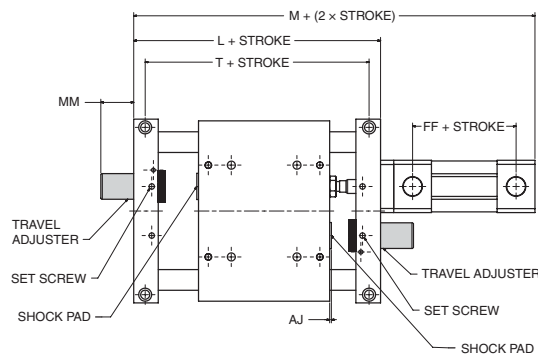
HBB



Model	L	T	M	FF	MM
HBB15	7.38	6.50	11.75	2.56	1.25
HBB20	8.38	7.00	12.75	2.56	1.00
HBB25	9.88	8.00	14.38	2.63	1.00

Stroke Adjusters and Shock Pads (E1, E2, E3)

HBB



Both Ends (E1)

Model	L	T	M	FF	MM	AJ
HBB15	7.63	6.75	12.00	2.56	1.25	0.13
HBB20	8.63	7.25	13.00	2.56	1.00	0.13
HBB25	10.13	8.25	14.63	2.63	1.00	0.13

Extend Only (E2)

Model	L	T	M	FF	MM	AJ
HBB15	7.38	6.50	11.75	2.56	1.25	0.13
HBB20	8.38	7.00	12.75	2.56	1.00	0.13
HBB25	9.88	8.00	14.38	2.63	1.00	0.13

Retract Only (E3)

Model	L	T	M	FF	MM	AJ
HBB15	7.25	6.38	11.63	2.56	1.25	0.13
HBB20	8.25	6.88	12.63	2.56	1.00	0.13
HBB25	9.75	7.88	14.25	2.63	1.00	0.13

All dimensions shown in inches.



For inventory, lead time, and kit lookup, visit [www.pdnplu.com](http://www.pdnplu.com)

E95

Parker Hannifin Corporation  
Pneumatic Division  
Richland, Michigan  
[www.parker.com/pneumatics](http://www.parker.com/pneumatics)

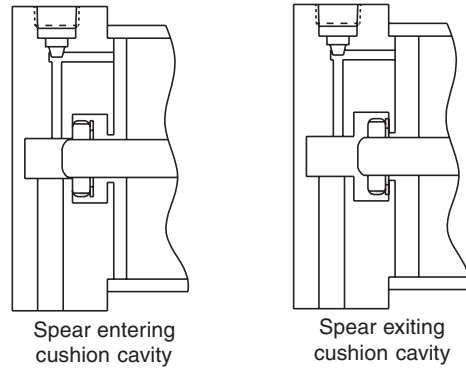
**Options**

**Cushions on Cylinder (C, C1, C2)**

Optional cylinder cushions are available at either or both ends. The check seal cushions float radially to compensate for problems with misalignment. Flow paths molded on the circumference of the seal allow exceptionally rapid return stroke without the use of ball checks. A captive cushion screw provides safe cushion adjustment while the cylinder is pressurized. The brass adjustment screw provides maximum corrosion resistance.

**Cushion Location\*:** The cushion adjustment screws are located on the same face as the port unless specified otherwise. The port is machined off-center to allow space for the cushion screw.

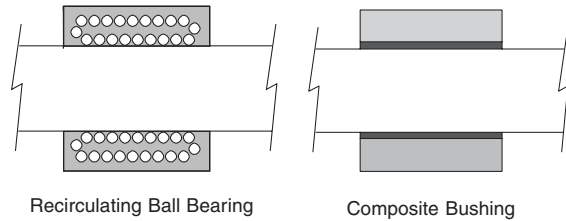
\* For steel cylinders, the cushion adjustment screw is located on the face opposite the port. Consult factory for other locations.



**Bushings (D, T, T1, TC)**

Selection should be based on the following criteria:

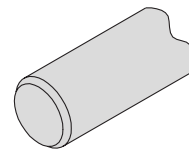
Application Requirement	Ball Bearing	Composite
Precision	Excellent	Good
Friction	Low	Higher
Friction Coefficient	Constant	Variable
Precision over Life of Bearing	Constant	Variable
Static Load Capacity	Good	Excellent
Dynamic Load Capacity	Good	Good with lower Efficiency
Lubrication	Required	Not required
Vibration Resistance	Fair	Excellent
Contamination Resistance	Fair	Excellent
Washdown Compatibility	Poor	Excellent



For bushing load capacities, reference the Engineering Data pages of this section.

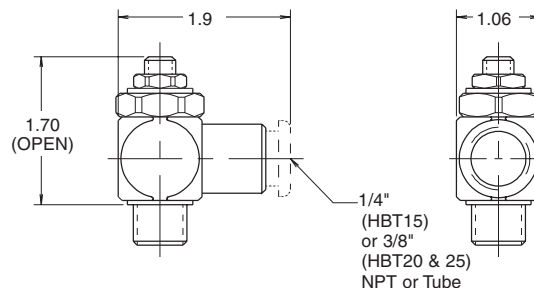
**Stainless Steel Shafts (K)**

Chrome plated, case-hardened carbon steel shafting is standard for slides. Stainless steel shafting can be specified for corrosive applications.



**Flow Controls (F, G)**

Right angle flow control valves allow precise adjustment of cylinder speed by metering exhaust air flow. Prestolok push-in or NPT ports provide 360° orientation capability.



All dimensions shown in inches.

**Guided Cylinders**  
 P5T Series  
 P5L Series  
 HB Series  
 P5E Series  
 XL Series



For inventory, lead times, and kit lookup, visit [www.pdnplu.com](http://www.pdnplu.com)

**Options**

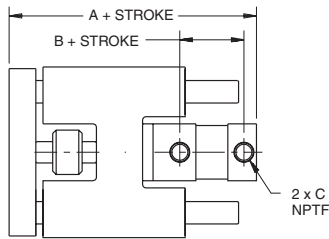
**NFPA Steel Air Cylinder (S)\***

Parker's 2A Series NFPA steel air cylinder is available for extremely rugged applications. Magnetic pistons are not available with this option. Consult factory for other switching or sensing options.

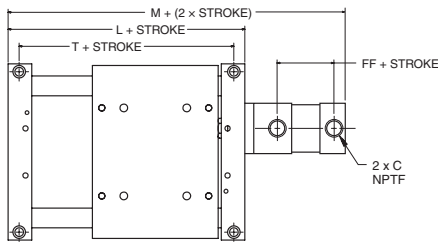
**250 PSI NFPA Air Cylinder (4A)**

Parker's 4MA Series aluminum NFPA air cylinders are available for general purpose use.

HBC  
HBT  
HBR



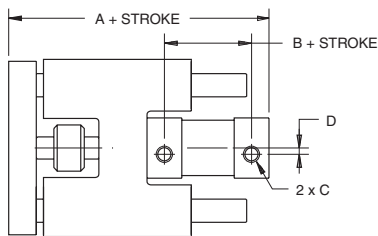
HBB



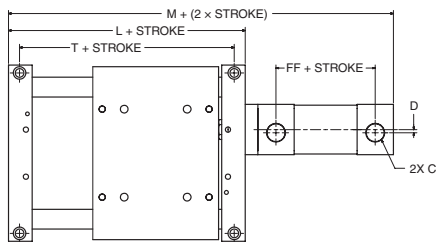
**ISO Air Cylinder (D, E)**

An ISO cylinder (Parker's P1D Series) is available for ISO or metric requirements. Magnetic pistons are standard. If sensors are required, they must be ordered from the Electronic Sensors section of this catalog.

HBC  
HBT  
HBR



HBB



All dimensions shown in inches.

**Guided Pneumatic Cylinders  
HB Series**

**400 PSI NFPA Hydraulic Cylinder (4L)**

Parker's 4ML Series aluminum NFPA cylinder is available for 400 PSI hydraulic service. Cushions are not available.

**750 PSI NFPA Hydraulic Cylinder (S1)\***

Parker's 3L Series NFPA steel cylinder is available for hydraulic service requiring higher force and precise control. Magnetic pistons are not available with this option. Consult factory for other switching or sensing options.

\* If cushions are specified with this option, the adjustment screw is located on the face opposite the port. Consult factory for other locations.

Model	A			B	C	Cylinder Bore (in)
	HBC	HBT	HBR			
15	C/F	8.56	11.56	2.25	3/8	1-1/2
20	C/F	9.31	13.81	2.25	3/8	2
25	C/F	10.69	16.2	2.38	3/8	2-1/2

C/F = Consult Factory

Model	L	T	M	C		Cylinder Bore (in)
				(NPTF)	FF	
15	7.00	6.13	C/F	3/8	2.25	1-1/2
20	8.00	6.63	C/F	3/8	2.25	2
25	9.50	7.63	C/F	3/8	2.38	2-1/2



Model	A			B	C		Bore (mm)
	HBC	HBT	HBR		BSPP	NPTF	
15	6.77	8.69	11.70	2.95	1/4	3/8	40
20	7.55	9.48	13.99	2.83	1/4	3/8	50
25	9.39	11.32	16.83	3.50	3/8	3/8	63

Model	L	T	M	C		D	FF	Bore (mm)
				BSPP	NPTF			
15	7.0	6.13	11.63	1/4	1/4	0.22	2.95	40
20	8.0	6.63	12.67	1/4	3/8	0.34	2.83	50
25	9.5	7.63	14.76	3/8	3/8	0.24	3.50	63



For inventory, lead time, and kit lookup, visit [www.pdnplu.com](http://www.pdnplu.com)

**Options**

**Guided Pneumatic Cylinders  
HB Series**

**Rod Lock Cylinder (D1, D2, E1, E2)**

The P1D Series Rod Lock Cylinder incorporates a powerful piston rod locking device, which clamps the piston rod and locks it in position. The locking device is a spring lock with an air pressure release and is integrated into the front (head) cover of the cylinder. This increases the cylinder length as shown below.

In the absence of air signal pressure, full holding force is applied to the piston rod. When air is present at 4 bar (58 PSI), the locking device is released. A manual override rod lock version is also available.

**Applications:** Vertical Guided Pneumatic Cylinders  
In the event of pressure loss  
In the event of electrical control failure

**Design Tip:** The piston rod should not be moving when the locking device is activated. The locking device is not intended to repeatedly brake movement. See sample pneumatic circuit.

**Note:** Rod locking cylinders automatically include cushions, but include cushions ("C") in model code. If sensors are required, they must be ordered from the Electronic Sensors section of this catalog.

**Technical Data**

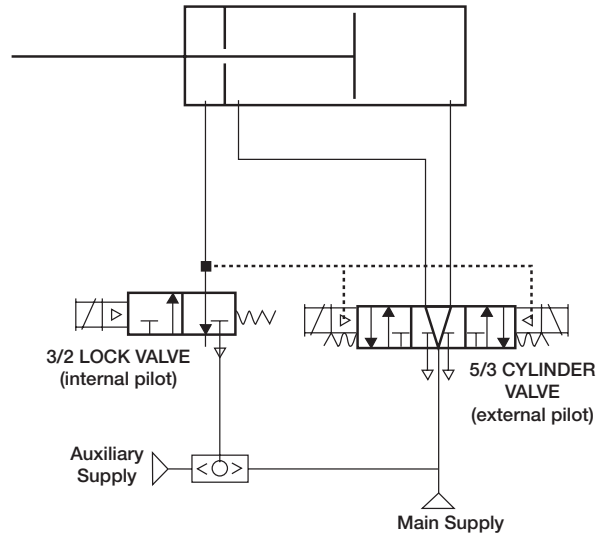
Maximum Pressure: 10 bar (145 PSI)  
Pressure Required to Unlock: 4 bar (58 PSI)<sup>1</sup>

<sup>1</sup> Signal pressure to port on locking device. Operation at pressures lower than 4 bar (58 PSI) may lead to inadvertent engagement of the rod lock device.

Model	Bore (mm)	Holding Force, lb (N)
15	40	193 (860)
20	50	303 (1345)
25	63	481 (2140)

**Rod Lock Circuit**

Lock valve must be maintained energized during cylinder motion, otherwise rod lock is engaged and cylinder valve shifts to mid position. For manual override of the rod lock, insert a shuttle valve and an auxiliary air supply to disable rod lock.



**NOTES:**

Cushion adjust (head only) located at position #4 for bore sizes 32-63mm. Head end port and cushion cannot be repositioned.

All P1D Rod Lock Versions are not intended for use in water service applications, or in environments that have high humidity levels and/or splashing fluids present.

Guided Cylinders

P5T Series

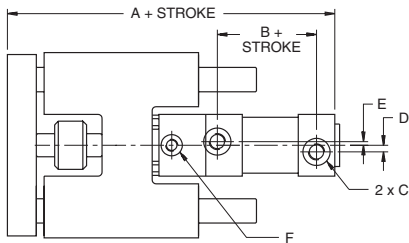
P5L Series

HB Series

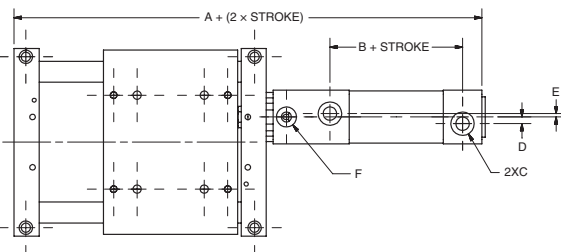
P5E Series

XL Series

**HBC  
HBT  
HBR**



**HBB**



Model	A								Cylinder bore (mm)
	HBC	HBT	HBR	B	C*	D	E	F*	
15	8.50	10.43	13.43	3.11	1/4	0.22	0.08	1/8	40
20	9.39	11.33	15.93	3.01	1/4	0.30	0.16	1/8	50
25	11.63	13.57	19.07	3.45	3/8	0.43	0.08	1/8	63

\*BSPP or NPTF

HBB Model	A						Cylinder bore (mm)
	A	B	C*	D	E	F*	
15	13.37	3.11	1/4	0.22	0.08	1/8	40
20	14.52	3.01	1/4	0.30	0.16	1/8	50
25	17.00	3.45	3/8	0.43	0.08	1/8	63

\*BSPP or NPTF

All dimensions shown in inches.



For inventory, lead times, and kit lookup, visit [www.pdnplu.com](http://www.pdnplu.com)

E98

**Parker Hannifin Corporation**  
Pneumatic Division  
Richland, Michigan  
[www.parker.com/pneumatics](http://www.parker.com/pneumatics)

**NFPA Rod Lock Cylinder (4J)**

The 4MAJ Series Rod Lock Cylinder incorporates a powerful piston rod locking device, which clamps the piston rod and locks it in position. The locking device is a spring lock with an air pressure release and is attached to the front (head) cover of the cylinder. This increases the cylinder length as shown below.

In the absence of air signal pressure, full holding force is applied to the piston rod. When air is present at 60 PSIG or greater, the locking device is released. The manual override version is standard.

**Applications:** Vertical Guided Pneumatic Cylinders  
In the event of pressure loss  
In the event of electrical control failure

**Design Tip:** The piston rod should not be moving when the locking device is activated. The locking device is not intended to repeatedly brake movement. See sample pneumatic circuit.

**Note:** Rod locking cylinders automatically include cushions, but include cushions ("C") in model code. If sensors are required, they must be ordered from the Electronic Sensors section of this catalog.

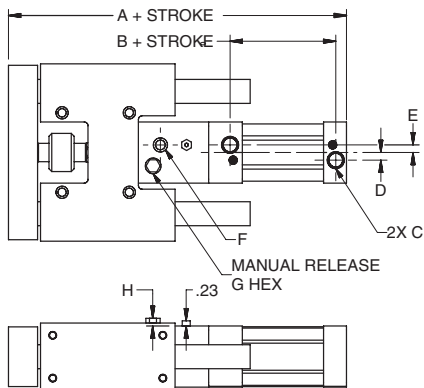
**Technical Data**

Maximum Pressure: 100 PSIG  
Pressure Required to Unlock: 60 PSIG<sup>1</sup>

<sup>1</sup> Signal pressure to port on locking device. Operation at pressures lower than 60 PSIG may lead to inadvertent engagement of the rod lock device.

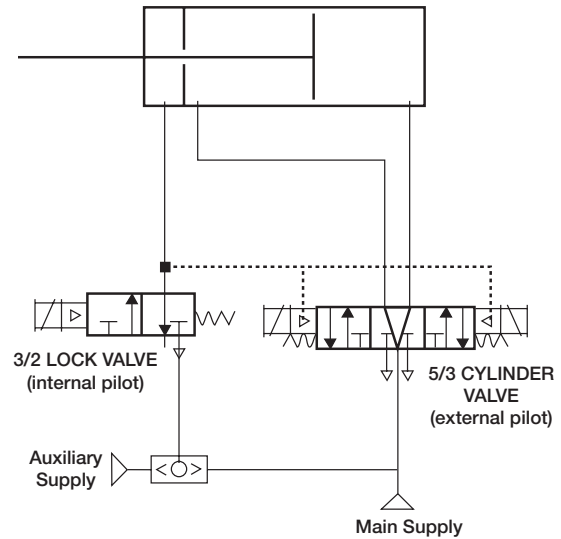
Model	Bore (inch)	Holding Force, lb
15	1-1/2	180
20	2	314
25	2-1/2	491

**HBC  
HBT  
HBR**



**Rod Lock Circuit**

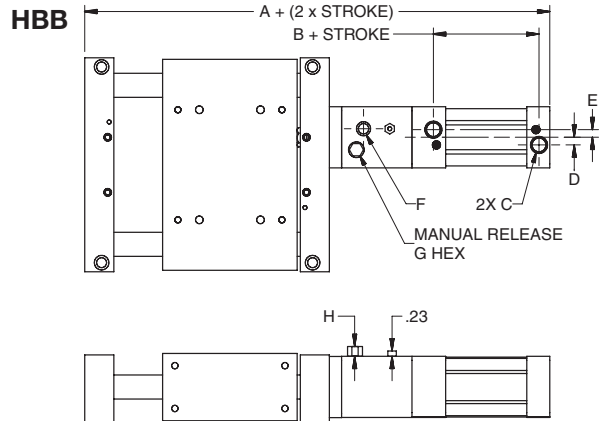
Lock valve must be maintained energized during cylinder motion, otherwise rod lock is engaged and cylinder valve shifts to mid position. For manual override of the rod lock, insert a shuttle valve and an auxiliary air supply to disable rod lock.



**NOTE:**

All 4MAJ rod lock cylinders are not intended for use in water service applications, or in environments that have high humidity levels and/or splashing fluids present.

**HBB**



Model	A				B	C NPTF	D	E	F NPTF	G HEX	H	Cylinder bore (inch)
	HBC	HBT	HBR	HBB								
15	8.89	10.82	13.82	14.26	2.31	3/8	0.31	0.31	1/8	5/16	0.19	1-1/2
20	9.88	11.82	16.32	15.51	2.31	3/8	0.31	0.31	1/8	1/2	0.27	2
25	11.26	13.19	18.70	17.13	2.38	3/8	0.31	0.31	1/8	1/2	0.27	2-1/2

All dimensions shown in inches.



For inventory, lead time, and kit lookup, visit [www.pdnplu.com](http://www.pdnplu.com)

**Options**

**Special (X)**

Other common modifications are available. Consult factory for specifications. Examples include:

- NC9 Series NFPA Pneumatic Cylinder
- 2AN Series NFPA Pneumatic Cylinder
- Cylinders with Continuous Position Feedback
- Bumpers on cylinder only

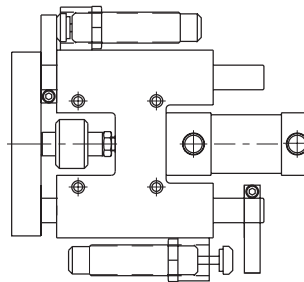
**No Cylinder (Q, Q1)**

The unit is supplied with cylinder mounting but no cylinder so that one may be field-added. Consult factory for required cylinder piston rod length.

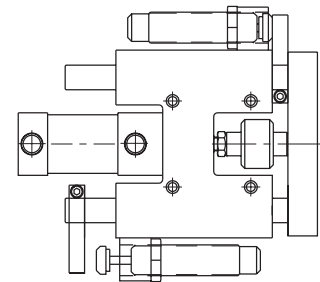
**Left Hand Assembly (L1)**

Units with shock absorbers can be assembled with shocks on the opposite sides.

**Standard Orientation**



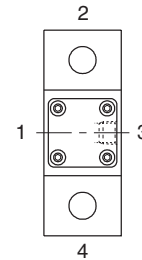
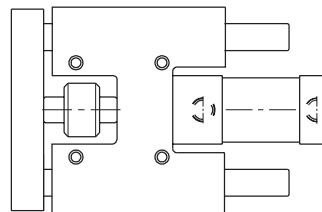
**Left Hand Orientation**



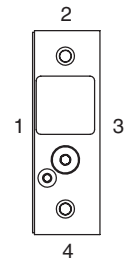
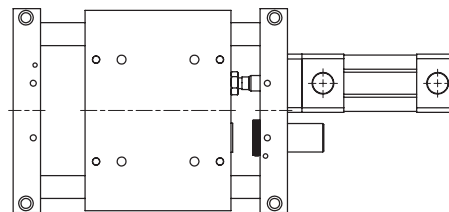
**Port Location (L3)**

Cylinder ports are located in position 3, opposite the standard position when L3 is specified. Port positions 2 and 4 are not possible.

**HBC  
HBT  
HBR**



**HBB**



**Fluorocarbon Seals (V)**

**Standard** abrasion-resistant nitrile seals should be used for general purpose applications with temperatures of 0 to 165°F.

**Fluorocarbon** seals are recommended for high temperature applications up to 250°F.

Option	Temperature range (°F)
Shock Absorbers	32 to 150
Bumpers	0 to 200
Piston Magnets	0 to 165
Sensors	14 to 140

**Guided Cylinders**

**Series**

- P5T Series
- P5L Series
- HB Series
- P5E Series
- XL Series



For inventory, lead times, and kit lookup, visit [www.pdnplu.com](http://www.pdnplu.com)



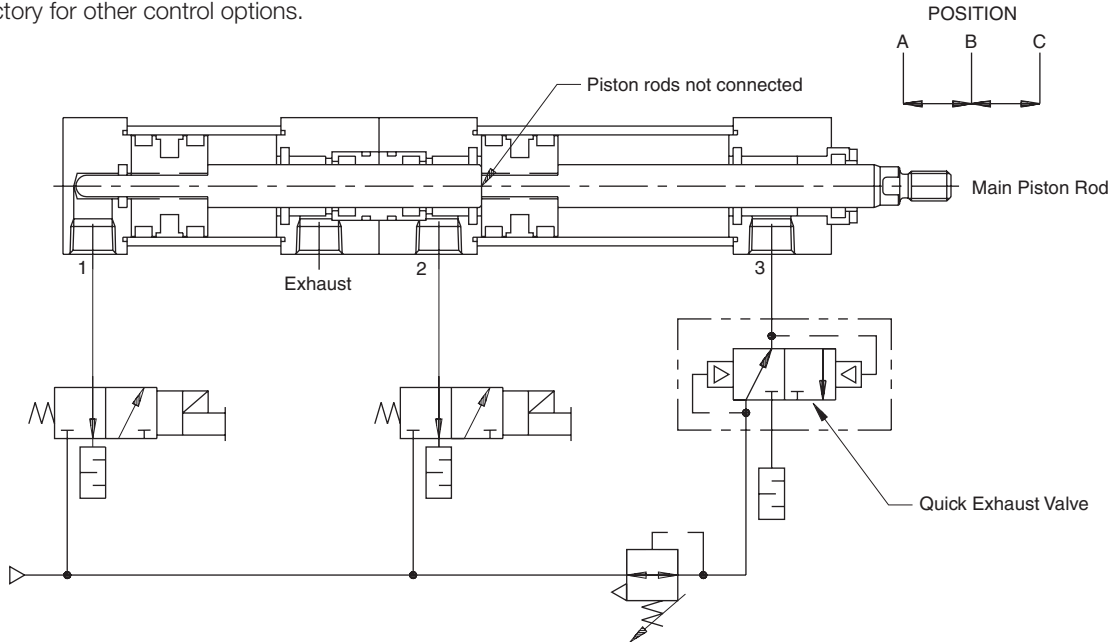
Options

Three Position Cylinder

The three position unit utilizes a duplex air cylinder to provide the center position. This option can be specified with all other options. However, bumpers and body mounted inductive proximity sensors operate on the fully extended and retracted positions only. Cylinder mounted reed and solid state sensors can be used to detect the center position of the slide.

Sample Circuit:

Consult factory for other control options.



Operation:

**Position A** (fully retracted) is obtained by applying pressure to Port 3 with Ports 2 and 1 vented to atmosphere.

**Position B** (mid-position) is obtained by applying pressure to Port 1 while maintaining a lower pressure to Port 3. The pressure at Port 3 prevents the main piston rod from over-travelling. A quick exhaust valve can be used to maintain pressure while allowing full exhaust capability.

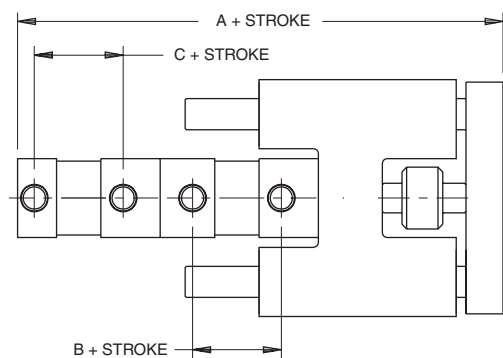
**Position C** (fully extended) is obtained by applying pressure to Port 2.

Dimensional Data:

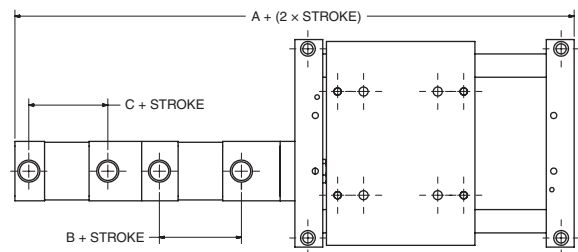
Three position units utilize a longer cylinder. All other dimensions remain the same.

	A					
Model	HBC	HBT	HBR	HBB	B	C
15	10.38	12.31	15.31	15.25	2.38	2.31
20	11.12	13.06	17.56	16.25	2.38	2.31
25	12.57	14.50	20.01	17.94	2.38	2.38


HBC  
HBT  
HBR



HBB



All dimensions shown in inches.

  
 Guided Cylinders  
 P5T Series  
 P5L Series  
 HB Series  
 P5E Series  
 XL Series



For inventory, lead time, and kit lookup, visit [www.pdnplu.com](http://www.pdnplu.com)

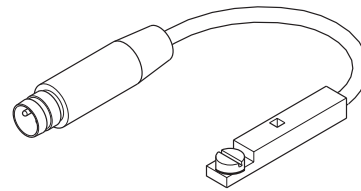
Options

Solid State and Reed Sensors

Sensors must be ordered separately.

Magnetic piston is standard.

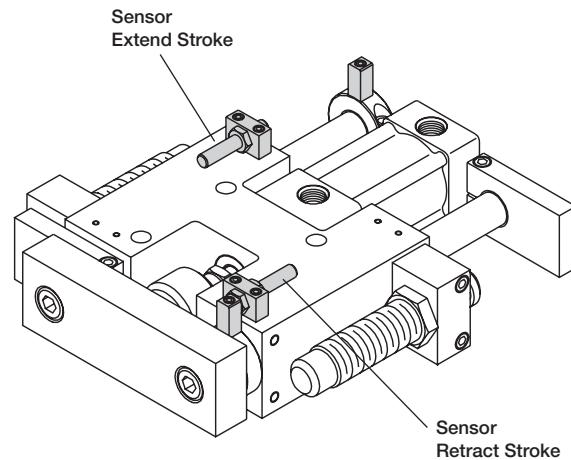
See Electronic Sensors section for part numbers and sensor specifications.




Inductive Proximity Sensors

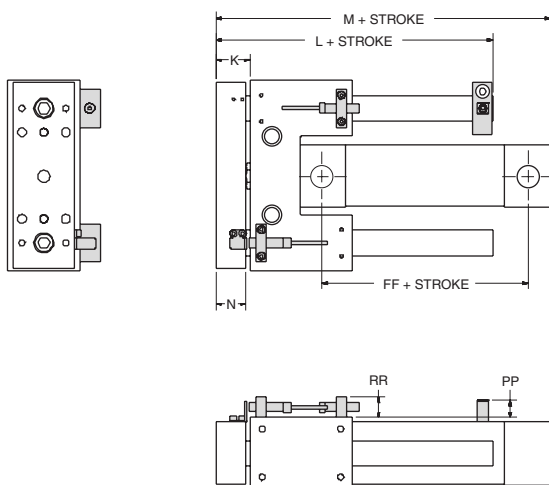
8mm barrel type proximity sensors may be ordered with the HB Series slides (options P, N, P1, N1). The slides can also be ordered "prox ready" (J, J1). A magnetic piston is standard.

See Electronic Sensors section for sensor specifications.



  
 Guided Cylinders  
 P5T Series  
 P5L Series  
 HB Series  
 P5E Series  
 XL Series

HBC



Model	K	L	M	N
HBC15	1.06	5.19	6.26	0.94
HBC20	1.31	6.39	7.00	1.19
HBC25	1.56	7.82	8.38	1.44

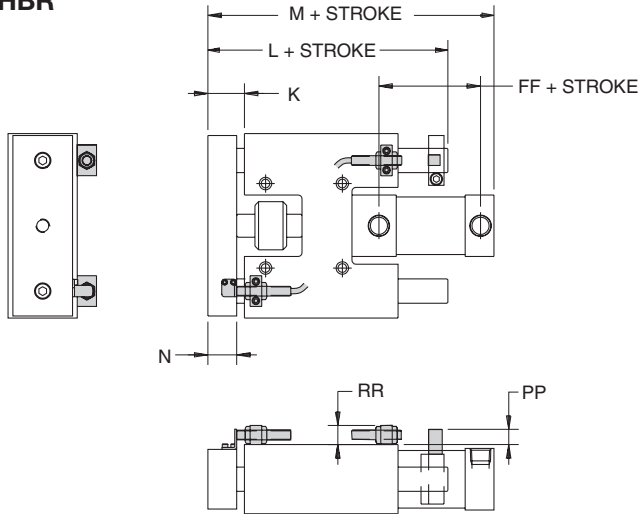
Model	RR			
	FF	PP	8mm	12mm
HBC15	2.31	0.50	0.63	0.88
HBC20	2.31	0.50	0.63	0.88
HBC25	2.38	0.50	0.63	0.88



For inventory, lead times, and kit lookup, visit [www.pdnplu.com](http://www.pdnplu.com)

Proximity Sensor

HBT  
HBR



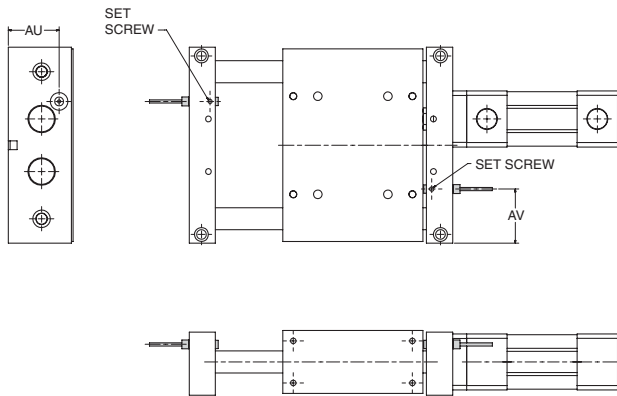
Model	K	L	M	N
HBT15	1.06	6.94	8.19	0.94
HBT20	1.31	7.88	8.94	1.19
HBT25	1.56	9.31	10.31	1.44

Model	FF	PP	RR	
			8mm	12mm
HBT15	2.31	0.50	0.63	0.88
HBT20	2.31	0.50	0.63	0.88
HBT25	2.38	0.50	0.63	0.88

Model	K	L	M	N
HBR15	1.06	9.94	11.19	0.94
HBR20	1.31	12.39	13.44	1.19
HBR25	1.56	14.82	15.82	1.44

Model	FF	PP	RR	
			8mm	12mm
HBR15	2.31	0.50	0.63	0.88
HBR20	2.31	0.50	0.63	0.88
HBR25	2.38	0.50	0.63	0.88

HBB



Model	AU	AV
HBB15	1.81	1.94
HBB20	2.19	2.63
HBB25	2.31	2.75

All dimensions shown in inches.

HB Series Service Kits

Cylinder type	Info location
4ML	pages B87-B90
4MAJ	page B91
P1D	page B120



Guided  
Cylinders

P5T  
Series

P5L  
Series

HB  
Series

P5E  
Series

XL  
Series



For inventory, lead time, and kit lookup, visit [www.pdnplu.com](http://www.pdnplu.com)

Features

P5E Series

**BUSHINGS**

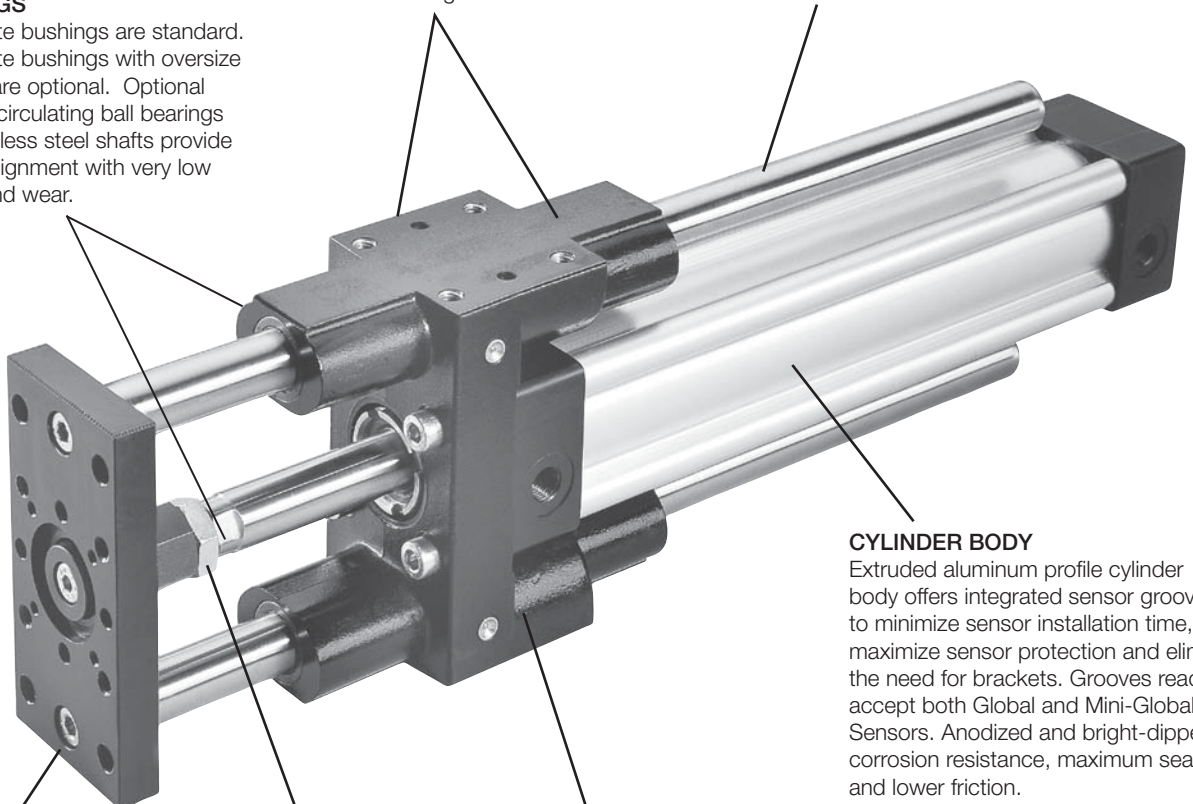
Composite bushings are standard. Composite bushings with oversize shafting are optional. Optional sealed recirculating ball bearings with stainless steel shafts provide precise alignment with very low friction and wear.

**CAST ALUMINUM BODY**

Lightweight, unitized design provides strength and 3 mounting faces.

**SUPPORT SHAFTS**

Chrome plated, case hardened support shafts are machined from high carbon alloy steel. Stainless steel and oversized shafting are available.



**CYLINDER BODY**

Extruded aluminum profile cylinder body offers integrated sensor grooves to minimize sensor installation time, maximize sensor protection and eliminate the need for brackets. Grooves readily accept both Global and Mini-Global Sensors. Anodized and bright-dipped for corrosion resistance, maximum seal life and lower friction.

**CYLINDER MOUNTING**

Conforms to ISO 6431, ISO/DIS 15552, VDMA 24562 and AFNOR standards

**TOOLING PLATE**

Precision machined and anodized, the aluminum tooling plate allows mounting on two sides. Dowel pin holes provide accurate mounting.

**ALIGNMENT COUPLER**

Allows piston rod to self-center, thus increasing cylinder life, especially when the support shafts deflect under load.

	Guided Cylinders
P5T Series	
P5L Series	
HB Series	
P5E Series	
XL Series	



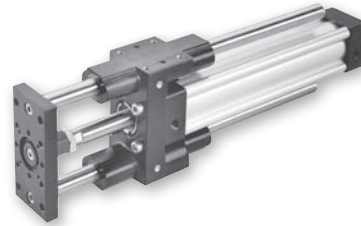
For inventory, lead times, and kit lookup, visit [www.pdnplu.com](http://www.pdnplu.com)

E104

**Parker Hannifin Corporation**  
Pneumatic Division  
Richland, Michigan  
[www.parker.com/pneumatics](http://www.parker.com/pneumatics)

**Features**

- Low profile guided assembly
- Powered by the P1D cylinder
- Bore sizes 32, 40, 50, 63, 80 and 100mm
- Strokes to any practical length
- Rod lock options available
- Composite and ball bearing options available



**Operating information**

Operating pressure:	145 PSIG (10 bar) maximum
Temperature range:	14°F to 165°F (-10°C to 74°C)
Filtration requirements:	40 micron, dry filtered air

**Ordering information**

**P5E - J 032 F G N 0250**

Shaft / bearing type		Bore size		Cylinder type <sup>3</sup>		Port Style		Stroke length		Bumpers / Adjustable Stop Collars	
<b>J</b>	Composite bearing, chrome plated standard shaft	<b>032</b>	32mm	<b>F</b>	P1D removable gland cylinder	<b>H</b>	NPTF (std)	<b>0250</b> Specify whole millimeters, i.e. 0250 = 250mm stroke		<b>N</b> None	
<b>M</b>	Composite bearing, chrome plated oversize shaft <sup>1</sup>	<b>040</b>	40mm	<b>G</b>	P1D removable gland cylinder with cushions	<b>G</b>	BSPP				
<b>C</b>	Composite bearing, stainless steel shaft	<b>050</b>	50mm	<b>K</b>	P1D rod lock cylinder with cushions	<b>N</b>	NPTF with flow controls (std. female ports)	<b>B</b> Bumpers, retract only <sup>2</sup>		<b>E</b> Bumpers and adjustable stop collars, extend only	
<b>H</b>	Ball bearing, stainless steel shaft	<b>063</b>	63mm	<b>S</b>	P1D manual override rod lock cylinder with cushions	<b>B</b>	BSPP with flow controls (ISO female ports)				
		<b>080</b>	80mm	<b>Q</b>	No cylinder	<b>F</b>	Flow controls, NPTF port, prestolok tube (inch)				
		<b>100</b>	100mm	<b>X</b>	Special – please specify	<b>P</b>	Flow controls, BSPP port, prestolok tube (mm)	<b>S</b> Bumpers and adjustable stop collars both ends <sup>2</sup>			

<sup>1</sup> Bumpers and adjustable stop collars are not available with oversize shaft option.

<sup>2</sup> These options will increase the cylinder length. To achieve a specific usable stroke length with these options, add the corresponding value(s) in the adder table, please reference P5E Removable Gland Version to the desired stroke length. See Bumper Options for explanation.

Adders are not used when P1D Rod Lock (K) or P1D Manual Override Rod Lock (S) are specified with bumpers.

<sup>3</sup> Tie Rod Version or composite piston option must be specified as Special (X).

**Sensors**  
See section L for sensors.

M	Guided Cylinders
P5T	Series
P5L	Series
HB	Series
P5E	Series
XL	Series



For inventory, lead time, and kit lookup, visit [www.pdnplu.com](http://www.pdnplu.com)

**General Specifications**

**Specifications**

- Maximum Operating Pressure: 145 PSI (10 Bar)
- Support Shaft Sizes: ø12 to 30mm
- Cylinder Mounting: ISO 6431, ISO/DIS 15552, VDMA 24 562 and AFNOR standards
- Mounting: Unrestricted
- Operating Temperature Range: -10°C to 74°C (14°F to 165°F)
- Filtration Requirement: 40 micron, dry filtered air



**Quick Reference Data**

Model (bore size)	Piston rod (mm)	Bushings	Support Shafts (mm)	Piston bore area non-rod side		Max.* Stroke (mm)	Theoretical force		Weights	
				(mm <sup>2</sup> )	(in <sup>2</sup> )		Extend @80 psi (5.5 bar), N (lb)	Retract @80 psi (5.5 bar), N (lb)	Base weight, kg (lb)	Per 100mm stroke, kg (lb)
32	16	Standard	12	804	1.25	500	444 (100)	334 (75)	0.97 (2.14)	0.175 (0.39)
		Oversized	16							
40	16	Standard	16	1257	1.95	625	694 (156)	583 (131)	1.55 (3.41)	0.315 (0.69)
		Oversized	20							
50	20	Standard	20	1964	3.04	775	1081 (243)	907 (204)	2.56 (5.64)	0.495 (1.09)
		Oversized	25							
63	20	Standard	20	3117	4.83	950	1717 (386)	1544 (347)	3.57 (7.84)	0.495 (1.09)
		Oversized	25							
80	25	Standard	25	5027	7.79	1150	2771 (623)	2500 (562)	6.53 (14.4)	0.770 (1.70)
		Oversized	30							
100	25	Standard	25	7854	12.17	1350	4333 (974)	4061 (913)	8.76 (19.32)	0.770 (1.70)
		Oversized	30							

\* Ball bearings suggested on long-stroke applications. Consult factory for longer strokes.

<b>U</b>	Guided Cylinders
<b>P5T</b>	Series
<b>P5L</b>	Series
<b>HB</b>	Series
<b>P5E</b>	Series
<b>XL</b>	Series



For inventory, lead times, and kit lookup, visit [www.pdnplu.com](http://www.pdnplu.com)

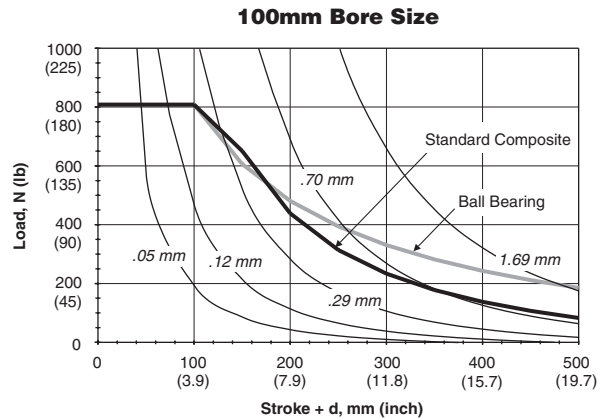
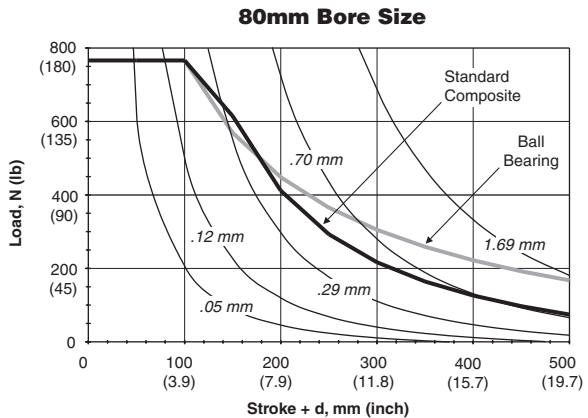
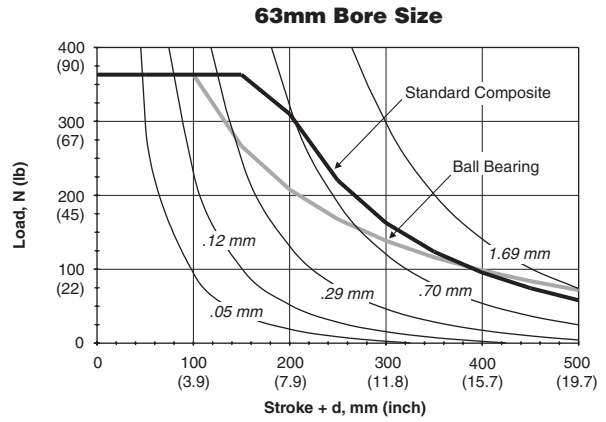
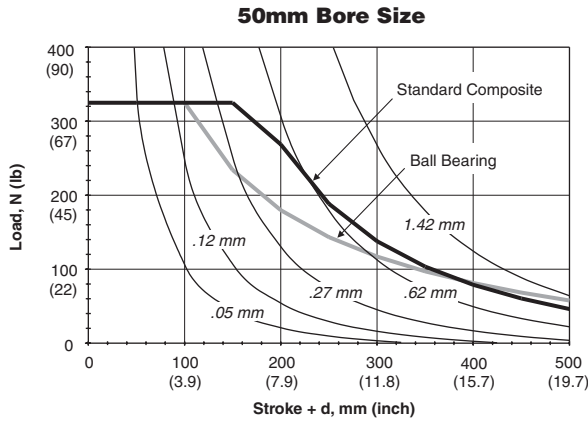
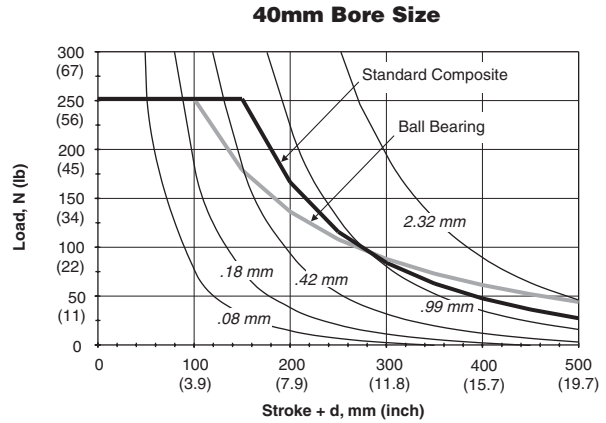
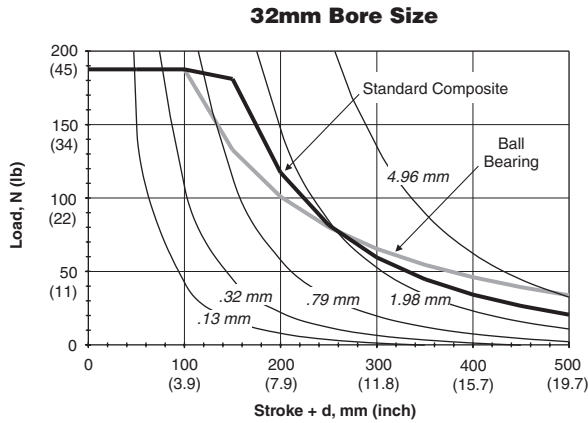
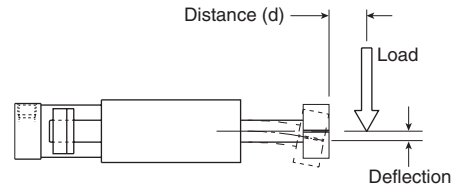
E106

**Parker Hannifin Corporation**  
Pneumatic Division  
Richland, Michigan  
[www.parker.com/pneumatics](http://www.parker.com/pneumatics)

**Maximum Load Capacity with Standard Shaft**

The following curves are based on 10 million cycles at a speed of 0.20 m/s (40 fpm). Higher dynamic loads will reduce cycle life. For static conditions, multiply the information in the graphs by 1.5.

**EXAMPLE:** A P5E with 40mm bore, composite bushings and a “stroke+d” of 400mm will have a load capacity of 48N.



<b>M</b>	Guided Cylinders
P5T Series	P5L Series
HB Series	P5E Series
XL Series	



For inventory, lead time, and kit lookup, visit [www.pdnplu.com](http://www.pdnplu.com)

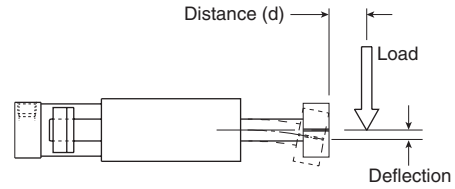
E107

**Parker Hannifin Corporation**  
Pneumatic Division  
Richland, Michigan  
[www.parker.com/pneumatics](http://www.parker.com/pneumatics)

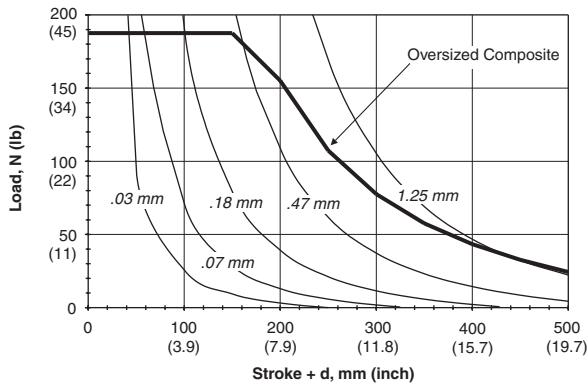
**Maximum Load Capacity with Oversized Shaft**

The following curves are based on 10 million cycles at a speed of 0.20 m/s (40 fpm). Higher dynamic loads will reduce cycle life. For static conditions, multiply the information in the graphs by 1.5.

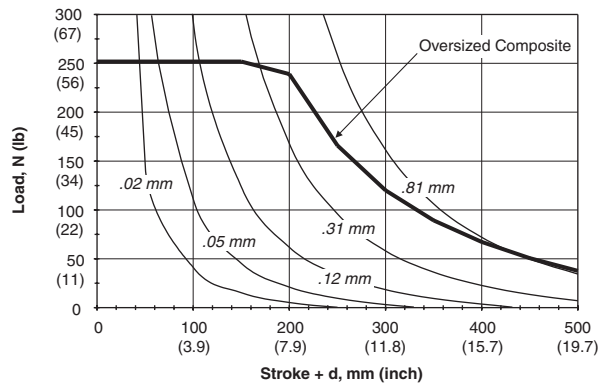
**EXAMPLE:** A P5E with 63mm bore, oversized support shafts and a "stroke+d" of 300mm would have a load capacity of 200N.



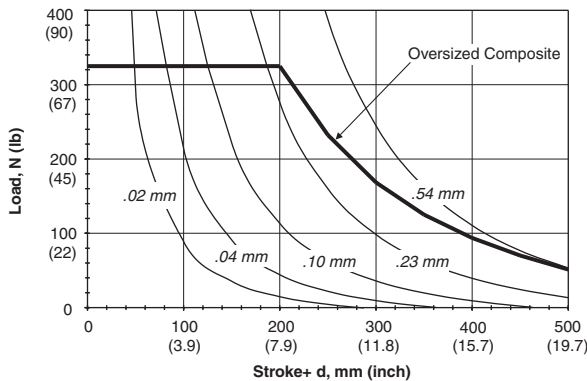
**32mm Bore Size**



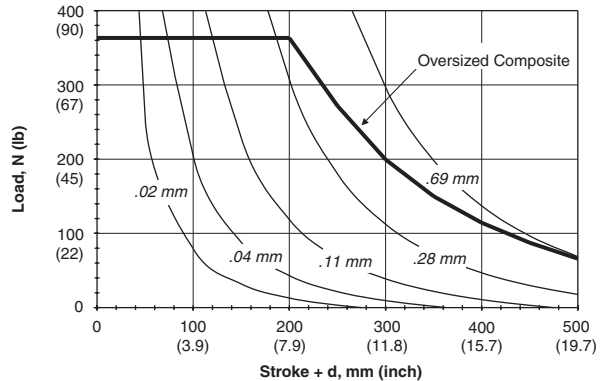
**40mm Bore Size**



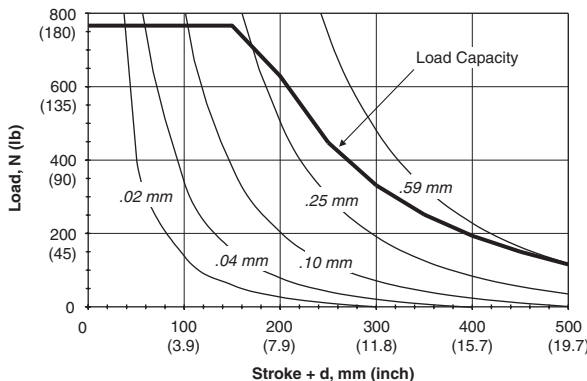
**50mm Bore Size**



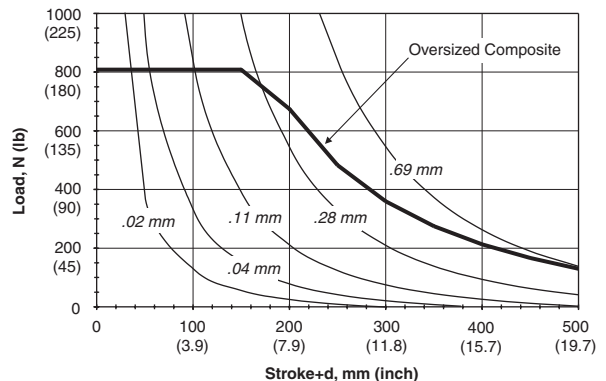
**63mm Bore Size**



**80mm Bore Size**



**100mm Bore Size**



	Guided Cylinders
	P5T Series
	P5L Series
HB Series	
P5E Series	
XL Series	



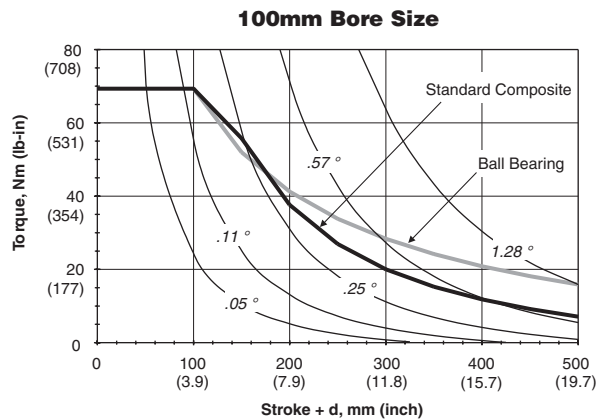
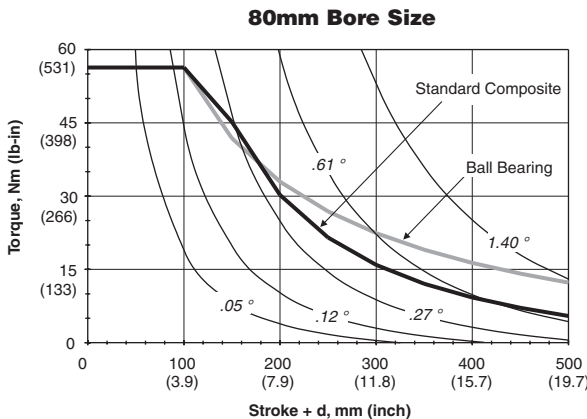
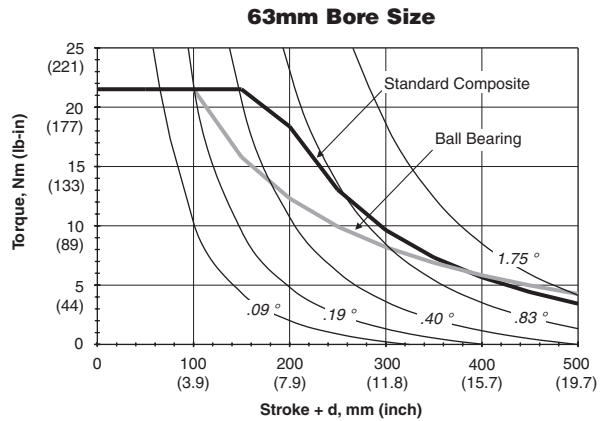
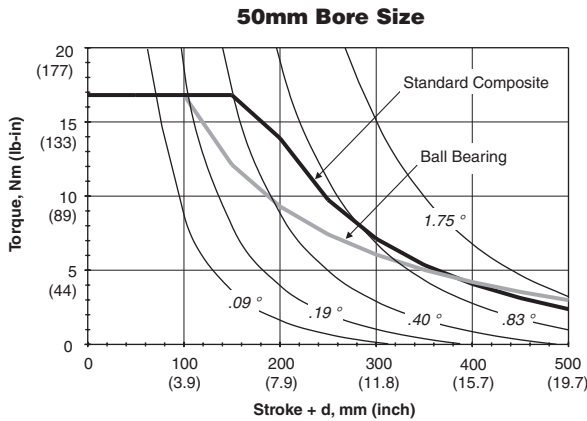
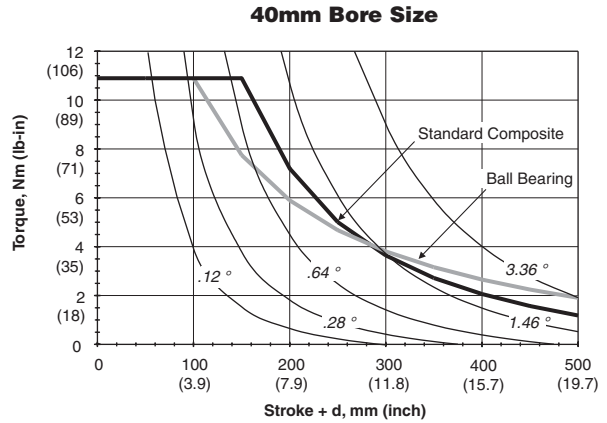
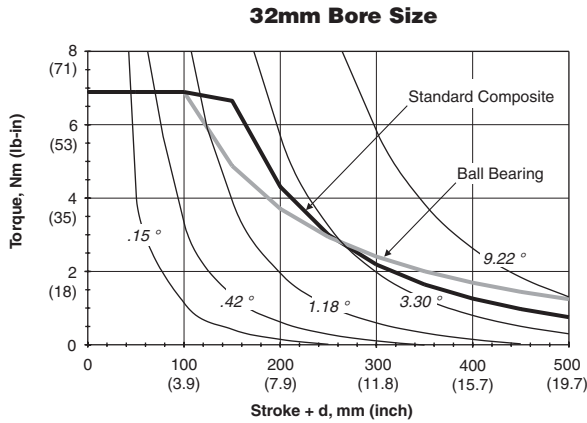
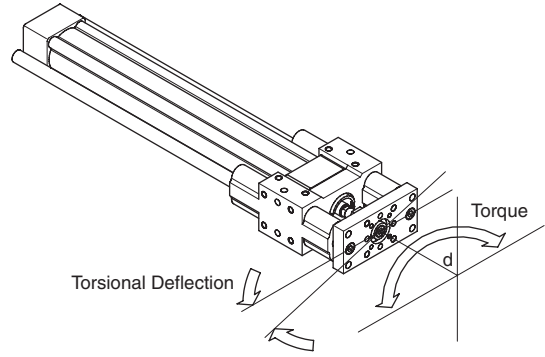
For inventory, lead times, and kit lookup, visit [www.pdnplu.com](http://www.pdnplu.com)



**Symmetrical Torque Capacity with Standard Shaft**

These curves provide the maximum permissible torsional load vs. stroke for various slide sizes. The data presented is based on a bearing life equivalent to 10 million cycles for dynamic conditions. Higher dynamic torques will reduce cycle life. For static conditions, multiply the information in the graphs by 1.5.

**EXAMPLE:** A P5E with 100mm bore, composite bushings and a "stroke + d" of 300mm would have a torque capacity of 20 Nm.



M	Guided Cylinders
	P5T Series
	P5L Series
	HB Series
	P5E Series
	XL Series

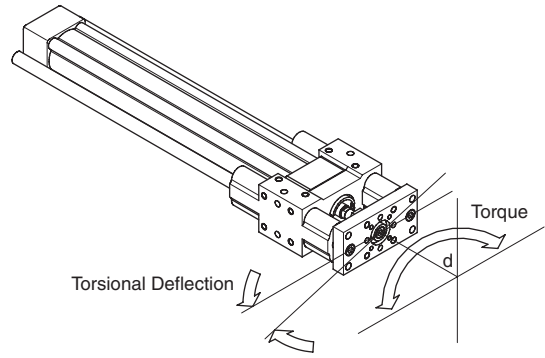


For inventory, lead time, and kit lookup, visit [www.pdnplu.com](http://www.pdnplu.com)

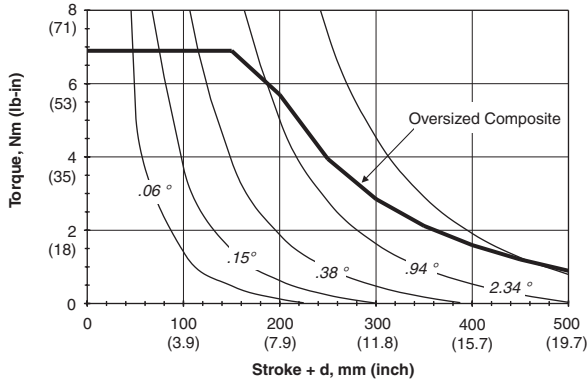
**Symmetrical Torque Capacity with Oversized Shaft**

These curves provide the maximum permissible torsional load vs. stroke for various slide sizes. The data presented is based on a bearing life equivalent to 10 million cycles for dynamic conditions. Higher dynamic torques will reduce cycle life. For static conditions, multiply the information in the graphs by 1.5.

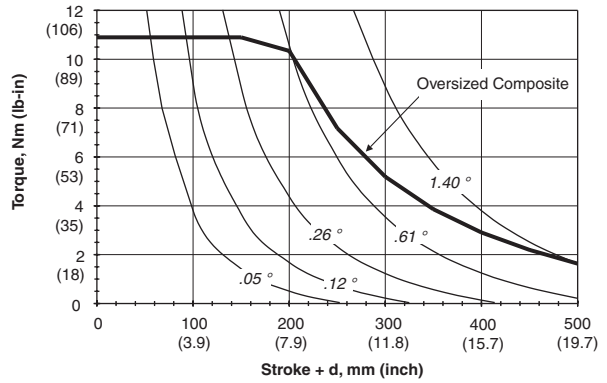
**EXAMPLE:** A P5E with 50mm bore, oversized support shafts and a "stroke + d" of 400mm would have a torque capacity of 5 Nm.



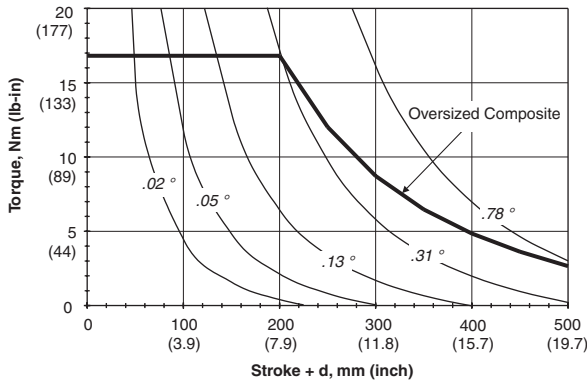
**32mm Bore Size**



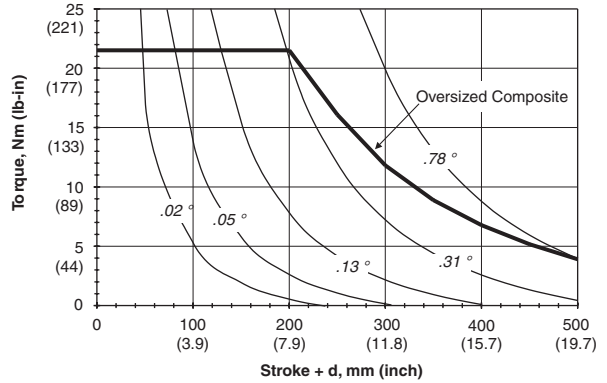
**40mm Bore Size**



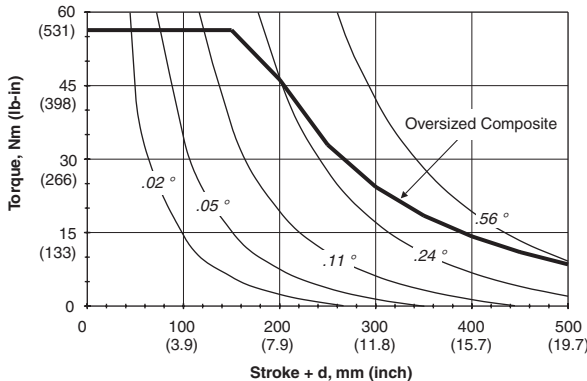
**50mm Bore Size**



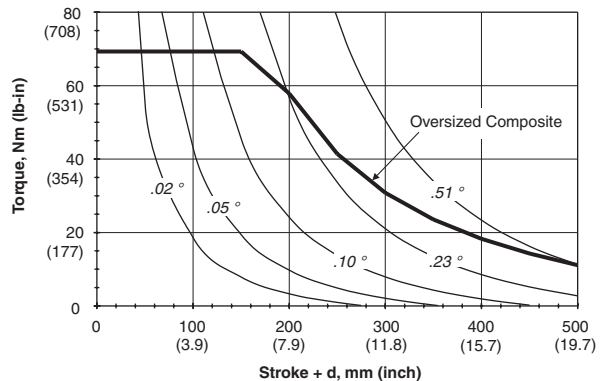
**63mm Bore Size**



**80mm Bore Size**



**100mm Bore Size**



Guided Cylinders	P5T Series
	P5L Series
HB Series	
P5E Series	
XL Series	

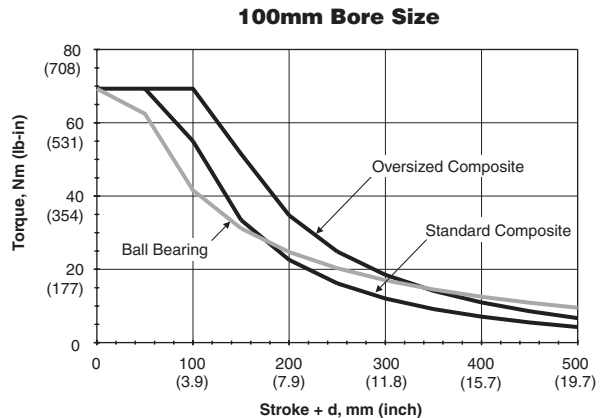
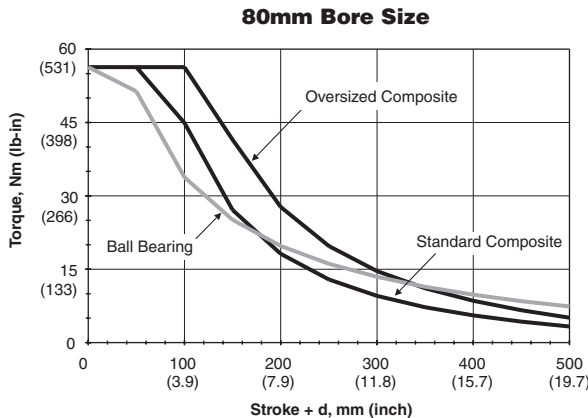
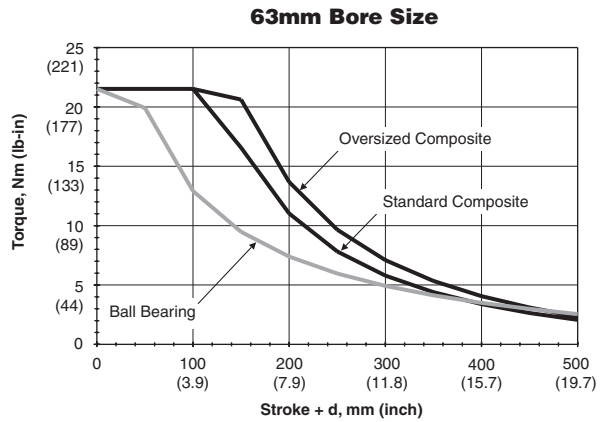
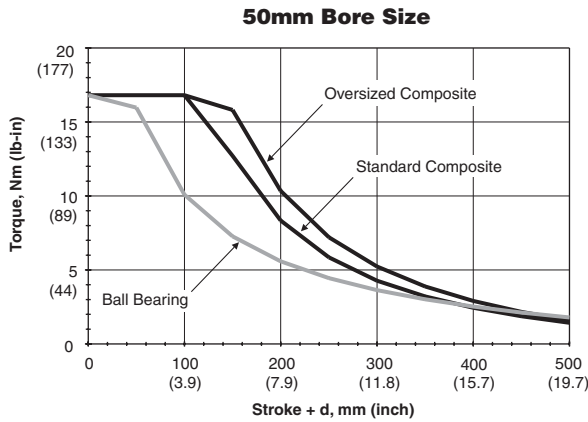
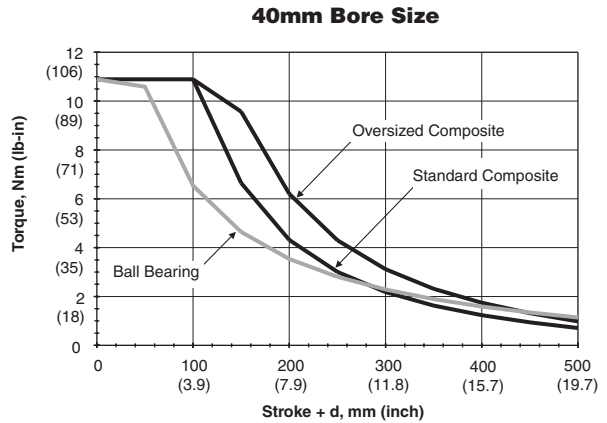
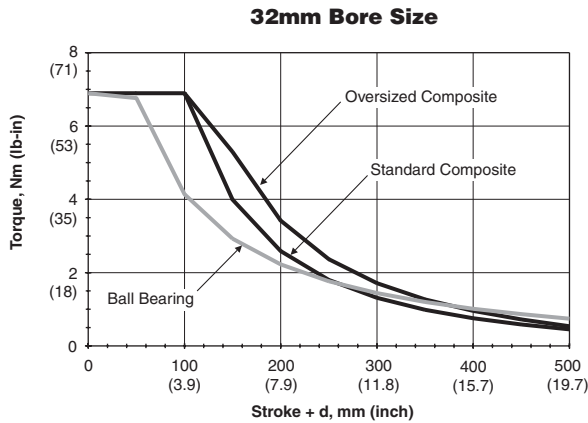
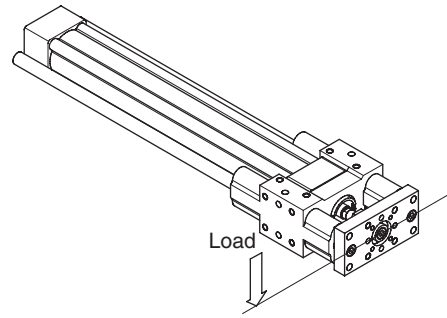


For inventory, lead times, and kit lookup, visit [www.pdnplu.com](http://www.pdnplu.com)

**Asymmetrical Torque Capacity**

Asymmetrical loading occurs when an off-center load is applied to the unit. P5E Series units can resist torsional loads that are asymmetrical.

**EXAMPLE:** A P5E with 63mm bore, ball bearings and a “stroke + d” of 300mm would have an asymmetrical torque capacity of 5 Nm.



M	Guided Cylinders
	P5T Series
	P5L Series
	HB Series
	P5E Series
	XL Series



For inventory, lead time, and kit lookup, visit [www.pdnplu.com](http://www.pdnplu.com)

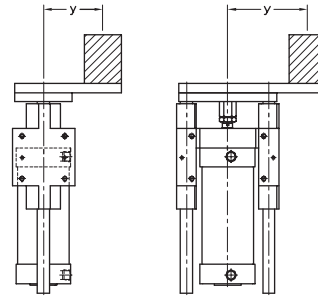
**Vertical Eccentric Load Capacity**

P5E Series units mounted vertically will have the same eccentric load capacity regardless of orientation. The graphs provide maximum load capacity for an eccentric mounted load. The load is assumed to be mounted at the face of the tooling plate.

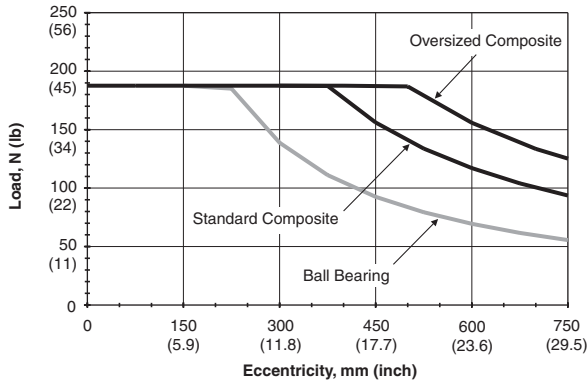
These load curves illustrate load ratings based on the bearing system of the product. Load rating is a key selection criterion but is not the only one to consider in the selection of a product.

**Note:** Charts are based on 100mm of stroke.

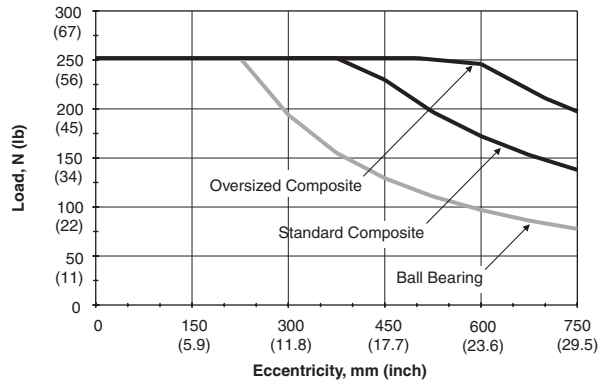
**EXAMPLE:** A P5E with a 40mm bore carrying an eccentric load located 300mm from the centerline has a capacity of approximately 200N (45 lbs).



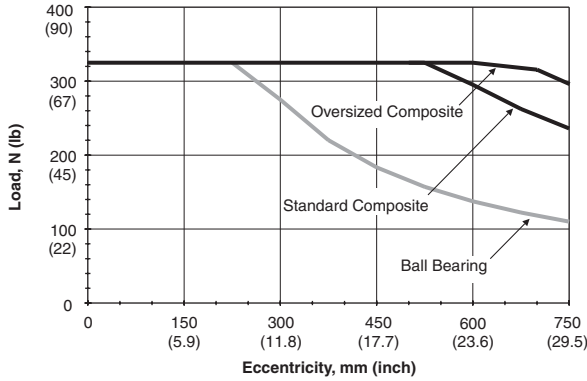
**32mm Bore Size**



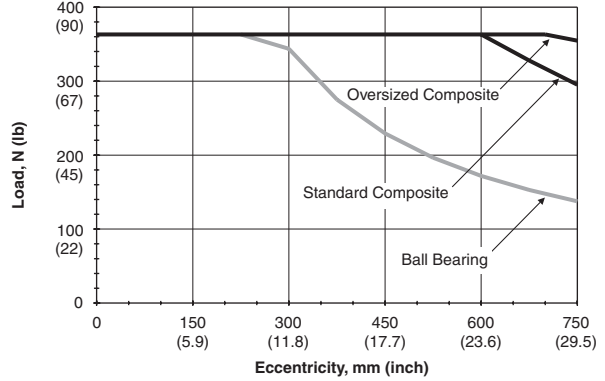
**40mm Bore Size**



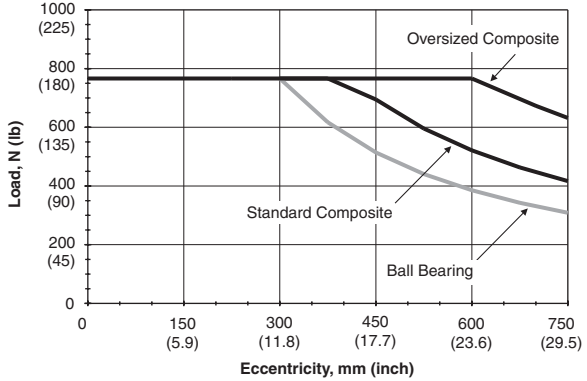
**50mm Bore Size**



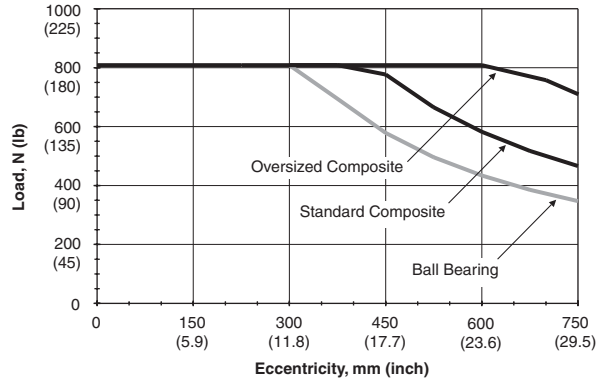
**63mm Bore Size**



**80mm Bore Size**



**100mm Bore Size**

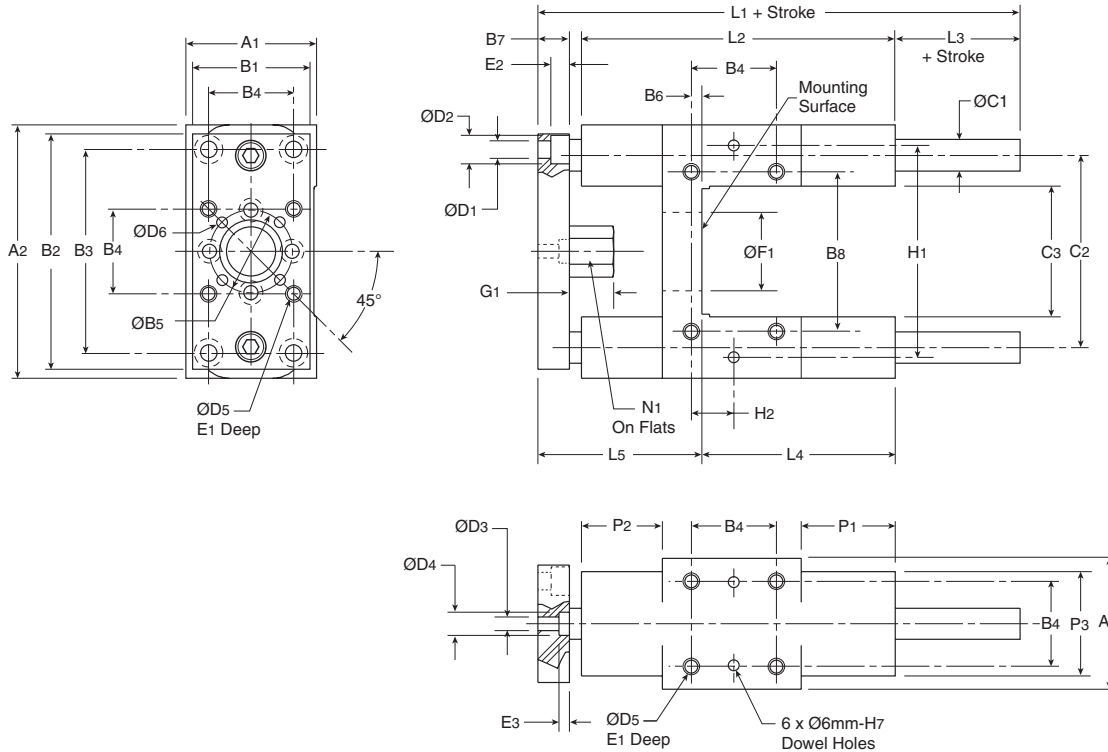


Guided Cylinders	P5T Series
	P5L Series
	HB Series
P5E Series	P5E Series
	XL Series



For inventory, lead times, and kit lookup, visit [www.pdnplu.com](http://www.pdnplu.com)

**Basic Version**



**Metric (inch)**

Bore size	A1	A2	B1	B2	B3	B4	ØB5	B6	B7	B8	ØC1 std.	ØC1 O.S.	C2	C3	ØD1	ØD2	ØD3	ØD4	ØD5	ØD6
32	50 (1.97)	97 (3.82)	45 (1.77)	92 (3.62)	78 (3.07)	32.5 (1.28)	31.5 (1.24)	4 (0.16)	12.7 (0.50)	61 (2.40)	12 (0.47)	16 (0.63)	73.5 (2.89)	50 (1.97)	6.6 (0.26)	11 (0.43)	5.2 (0.20)	9 (0.35)	M6 x 1.00	4 (0.16)
40	58 (2.28)	115 (4.53)	50.8 (2.00)	110 (4.33)	84 (3.31)	38 (1.50)	31.5 (1.24)	11 (0.43)	12.7 (0.50)	69 (2.72)	16 (0.63)	20 (0.79)	86.5 (3.41)	58 (2.28)	6.6 (0.26)	11 (0.43)	5.2 (0.20)	9 (0.35)	M6 x 1.00	4 (0.16)
50	70 (2.76)	137 (5.39)	63 (2.48)	132 (5.20)	100 (3.94)	46.5 (1.83)	50 (1.97)	19 (0.75)	16 (0.63)	85 (3.35)	20 (0.79)	25 (0.98)	103.5 (4.07)	70 (2.76)	9 (0.35)	14 (0.55)	6.4 (0.25)	11 (0.43)	M8 x 1.25	4 (0.16)
63	85 (3.35)	152 (5.98)	82.5 (3.25)	145 (5.71)	105 (4.13)	56.5 (2.24)	50 (1.97)	15 (0.59)	16 (0.63)	100 (3.94)	20 (0.79)	25 (0.98)	118.5 (4.67)	85 (3.35)	9 (0.35)	14 (0.55)	6.4 (0.25)	11 (0.43)	M8 x 1.25	4 (0.16)
80	105 (4.13)	189 (7.44)	100 (3.94)	180 (7.09)	130 (5.12)	72 (2.83)	76 (2.99)	21 (0.83)	19 (0.75)	130 (5.12)	25 (0.98)	30 (1.18)	147 (5.79)	105 (4.13)	11 (0.43)	17 (0.67)	8.4 (0.33)	14 (0.55)	M10 x 1.50	6 (0.24)
100	130 (5.12)	213 (8.39)	120 (4.72)	200 (7.87)	150 (5.91)	89 (3.50)	76 (2.99)	24.5 (0.97)	19 (0.75)	150 (5.91)	25 (0.98)	30 (1.18)	171.5 (6.75)	130 (5.12)	11 (0.43)	17 (0.67)	8.4 (0.33)	14 (0.55)	M10 x 1.50	6 (0.24)

Bore size	E1	E2	E3	ØF1	G1	H1	H2	L1	L2	L3	L4	L5	N1	P1	P2	P3	Port size	Piston rod thread
32	12 (0.47)	7 (0.28)	4 (0.16)	30 (1.18)	17 (0.67)	81 (3.19)	16 (0.63)	153 (6.02)	120 (4.72)	17 (0.67)	71 (2.80)	64.7 (2.55)	17 (0.67)	36 (1.42)	31 (1.22)	40 (1.57)	1/8	M10 x 1.25
40	12 (0.47)	7 (0.28)	4 (0.16)	35 (1.38)	24 (0.94)	99 (3.90)	19 (0.75)	166 (6.54)	130 (5.12)	20 (0.79)	71 (2.80)	74.7 (2.94)	17 (0.67)	36 (1.42)	36 (1.42)	44 (1.73)	1/4	M12 x 1.25
50	16 (0.63)	9 (0.35)	9 (0.35)	40 (1.57)	27 (1.06)	119 (4.69)	23 (0.91)	194 (7.64)	150 (5.90)	25 (0.98)	79 (3.11)	90 (3.54)	24 (0.94)	42 (1.65)	44 (1.73)	50 (1.97)	1/4	M16 x 1.5
63	16 (0.63)	9 (0.35)	9 (0.35)	45 (1.77)	27 (1.06)	132 (5.20)	28 (1.10)	224 (8.82)	180 (7.09)	25 (0.98)	109 (4.29)	90 (3.54)	24 (0.94)	58 (2.28)	44 (1.73)	60 (2.36)	3/8	M16 x 1.5
80	20 (0.79)	11 (0.43)	5 (0.19)	45 (1.77)	32 (1.26)	166 (6.54)	36 (1.42)	252 (9.92)	200 (7.87)	30 (1.18)	113 (4.45)	109 (4.29)	30 (1.18)	50 (1.97)	52 (2.05)	70 (2.76)	3/8	M20 x 1.5
100	20 (0.79)	11 (0.43)	5 (0.20)	55 (2.17)	32 (1.26)	190 (7.48)	45 (1.77)	272 (10.71)	220 (8.66)	30 (1.18)	128 (5.04)	114 (4.49)	30 (1.18)	49 (1.93)	51 (2.01)	70 (2.76)	1/2	M20 x 1.5

**M**

Guided  
Cylinders

---

P5T  
Series

---

P5L  
Series

---

HB  
Series

---

P5E  
Series

---

XL  
Series



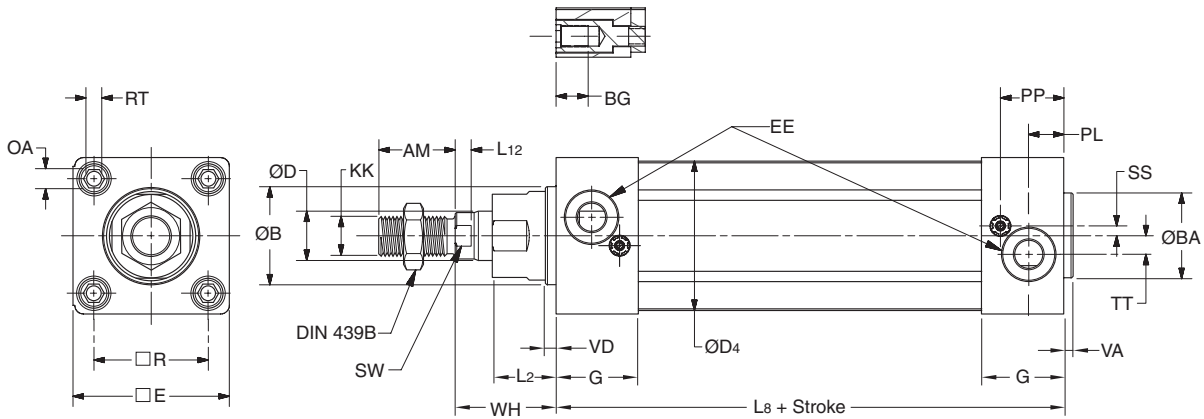
For inventory, lead time, and kit lookup, visit [www.pdnplu.com](http://www.pdnplu.com)

E113

**Parker Hannifin Corporation**  
Pneumatic Division  
Richland, Michigan  
[www.parker.com/pneumatics](http://www.parker.com/pneumatics)

Options

P1D Removable Gland Version



Dimensions

Cylinder bore	AM mm	B mm	BA mm	BG mm	D mm	D4 mm	E mm	EE		G mm	KK	L2 mm	L8 mm	L12 mm
								BSPP	NPTF/BSPT					
32	22	30	30	16	12	45.0	46.5	G1/8	1/8	28.5	M10x1.25	18	94	6.0
40	24	35	35	16	16	52.0	52.0	G1/4	1/4	33.0	M12x1.25	20	105	6.5
50	32	40	40	16	20	60.7	63.5	G1/4	1/4	33.5	M16x1.5	26	106	6.5
63	32	45	45	16	20	71.5	76.0	G3/8	3/8	39.5	M16x1.5	26	121	6.5
80	40	45	45	17	25	86.7	95.5	G3/8	3/8	39.5	M20x1.5	33	128	10.0
100	40	55	55	17	25	106.7	114.5	G1/2	1/2	44.5	M20x1.5	33	138	10.0

Cylinder bore	OA mm	PL mm	PP mm	R mm	RT	SS mm	SW mm	TT mm	VA mm	VD mm	WH mm
40	6	14	21.9	38.0	M6	8.0	13	5.5	3.5	4.5	30
50	8	14	25.9	46.5	M8	4.0	17	7.5	3.5	4.5	37
63	8	16	27.4	56.5	M8	6.5	17	11.0	3.5	4.5	37
80	6	16	30.5	72.0	M10	0	22	15.0	3.5	4.5	46
100	6	18	35.8	89.0	M10	0	22	20.0	3.5	4.5	51

S = Stroke

Tolerances

Cylinder bore	B	BA mm	L8 mm	L9 mm	R mm	Stroke tolerance
32	d11	d11	±0.4	±2	±0.5	+1/-0
40	d11	d11	±0.7	±2	±0.5	+1/-0
50	d11	d11	±0.7	±2	±0.6	+1/-0
63	d11	d11	±0.8	±2	±0.7	+1/-0
80	d11	d11	±0.8	±3	±0.7	+1/-0
100	d11	d11	±1.0	±3	±0.7	+1/-0

\*Stroke Adder for Cylinder Bumper Options

Cylinder bore	Option				
	B	T	R	S	E
32, 40, 50	5	25	25	25	25
63, 80	(0.20)	(0.98)	(0.98)	(0.98)	(0.98)
100	5	5	25	25	0
	(0.20)	(0.20)	(0.98)	(0.98)	

Adder dimensions in mm (inch)

Note: Adders not used when P1D Rod Lock (K) and P1D Manual Override Rod Lock (S) are specified with bumpers.

**P**  
 Guided Cylinders  
 P5T Series  
 P5L Series  
 HB Series  
 P5E Series  
 XL Series



For inventory, lead times, and kit lookup, visit [www.pdnplu.com](http://www.pdnplu.com)

E114

Parker Hannifin Corporation  
Pneumatic Division  
Richland, Michigan  
[www.parker.com/pneumatics](http://www.parker.com/pneumatics)

**P1D Rod Lock (K, S)**

The P1D Series Rod Lock Cylinder incorporates a powerful piston rod locking device, which clamps the piston rod and locks it in position. The locking device is a spring lock with an air pressure release and is integrated into the front (head) cover of the cylinder. In the absence of air signal pressure, full holding force is applied to the piston rod. When air is present at 4 bar (58 psi), the locking device is released.

The design provides several valuable characteristics, such as:

- A holding force corresponding to a pressure of 7 bar (102 psi)
- A clean design, with the front (head) end cover and locking device built into a common block for compact installation.
- Easy to clean, well-sealed construction.
- Exhaust air from the locking device can be piped away when there are high demands for contaminant free environment.

**Note:** The P1D with rod lock product line is not intended for use in water service applications, or in environments that have high humidity levels and/or splashing fluids present.

**Specifications**

- Fluid Medium: Dry, filtered, compressed air
  - Maximum Cylinder Operating Pressure: 10 bar (145 PSI)
  - Required Pressure to Unlock<sup>1</sup>: 4 bar (58 PSI)
  - Minimum Torque Required for Override:
    - 32mm Bore = 0.9 N-m / 8 in-lbs
    - 40mm Bore = 0.9 N-m / 8 in-lbs
    - 50mm Bore = 2.7 N-m / 24 in-lbs
    - 63mm Bore = 2.7 N-m / 24 in-lbs
    - 80mm Bore = 27.1 N-m / 240 in-lbs
    - 100mm Bore = 36.6 N-m / 324 in-lbs
  - Maximum Operating Temperature: -10°C to 75°C, 14°F to 167°F
  - Maximum Cylinder Operating Speed: 5 feet per second
- <sup>1</sup> Signal pressure to port on locking device. Operation at pressures lower than 4 Bar (58 psi) may lead to inadvertent engagement of the rod lock device.

**Connection**

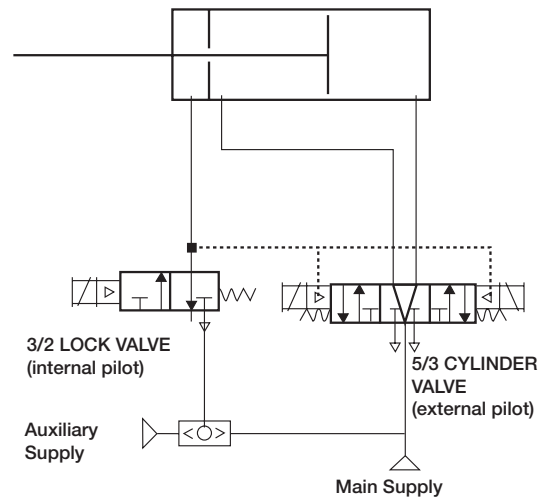
The signal air for the locking device can be obtained directly from a main air supply, or from the air supply serving the valve that controls the cylinder itself. For controlled ON/OFF operation of the locking device, a separate quick-venting valve is used.

The piston rod should not be moving when the locking device is activated. The locking device is not intended to brake a movement in repeated sequences.

**Holding Forces**

Bore size	Holding forces	
	(N)	(lbs)
32mm	550	123
40mm	860	193
50mm	1345	303
63mm	2140	481
80mm	3450	755
100mm	5390	1211

**Note:** All P1D Rod Lock Versions are not intended for use in water service applications, or in environments that have high humidity levels and/or splashing fluids present.



1. Lock valve must be maintained energized during cylinder motion, otherwise rod lock is engaged and cylinder valve shifts to mid position.
2. Cylinder valve must be maintained energized during extend or retract. Also keep energized at end of stroke until change of direction is desired.
3. Mid position of 5/3 Cylinder valve may be pressurized outlets if the combination of pressure load on the cylinder and inertia effects of the attached load do not exceed the holding force rating of the rod lock device, including allowance for wear.
4. Do not use cylinder lines for any logic functions — pressure levels vary too much.

**M**

Guided Cylinders

P5T Series

P5L Series

HB Series

P5E Series

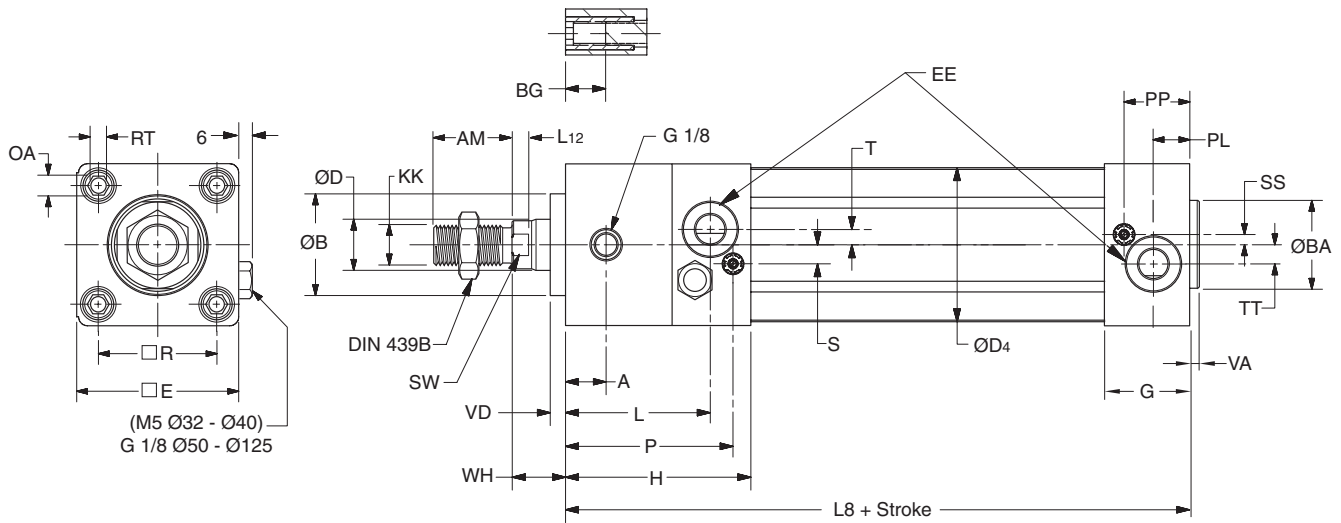
XL Series



For inventory, lead time, and kit lookup, visit [www.pdnplu.com](http://www.pdnplu.com)

Options

P1D Rod Lock Version (K)



Dimensions

Cylinder bore	A mm	AM mm	B mm	BA mm	BG mm	D mm	D4 mm	E mm	EE	G mm	H mm	KK	L mm	L8 mm	L12 mm
32	16	22	30	30	16	12	45.0	46.5	G1/8	28.5	71.5	M10x1.25	56.0	137	6.0
40	16	24	35	35	16	16	52.0	52.0	G1/4	33.0	77.0	M12x1.25	56.0	149	6.5
50	18	32	40	40	16	20	60.7	63.5	G1/4	33.5	80.5	M16x1.5	62.5	153	6.5
63	26	32	45	45	16	20	71.5	76.0	G3/8	39.5	96.5	M16x1.5	74.5	178	6.5
80	35	40	45	45	17	25	86.7	95.5	G3/8	39.5	110.5	M20x1.5	87.0	199	10.0
100	50	40	55	55	17	25	106.7	114.5	G1/2	44.5	132.5	M20x1.5	106.0	226	10.0

Cylinder bore	OA mm	P mm	PL mm	PP mm	R mm	RT mm	S mm	SS mm	SW mm	T mm	TT mm	VA mm	VD mm	WH mm
32	6	64.8	13	21.8	32.5	M6	7	6.5	10	2.5	4.5	3.5	4.5	15
40	6	68.0	14	21.9	38.0	M6	9	8.0	13	2.0	5.5	3.5	4.5	16
50	8	73.5	14	25.9	46.5	M8	8	4.0	17	4.0	7.5	3.5	5.0	17
63	8	89.5	16	27.4	56.5	M8	8	6.5	17	2.0	11.0	3.5	5.0	17
80	6	101.5	16	30.5	72.0	M10	9	0	22	5.0	15.0	3.5	4.0	20
100	6	123.5	18	35.8	89.0	M10	12	0	22	6.0	20.0	3.5	4.0	20

Tolerances

Cylinder bore	B mm	R mm	L8 mm	BA mm	Stroke-length mm
32	d11	±0.5	±0.4	d11	+1/-0
40	d11	±0.5	±0.7	d11	+1/-0
50	d11	±0.6	±0.7	d11	+1/-0
63	d11	±0.7	±0.8	d11	+1/-0
80	d11	±0.7	±0.8	d11	+1/-0
100	d11	±0.7	±1.0	d11	+1/-0

**P**  
 Guided Cylinders  
 P5T Series  
 P5L Series  
 HB Series  
 P5E Series  
 XL Series



For inventory, lead times, and kit lookup, visit [www.pdnplu.com](http://www.pdnplu.com)

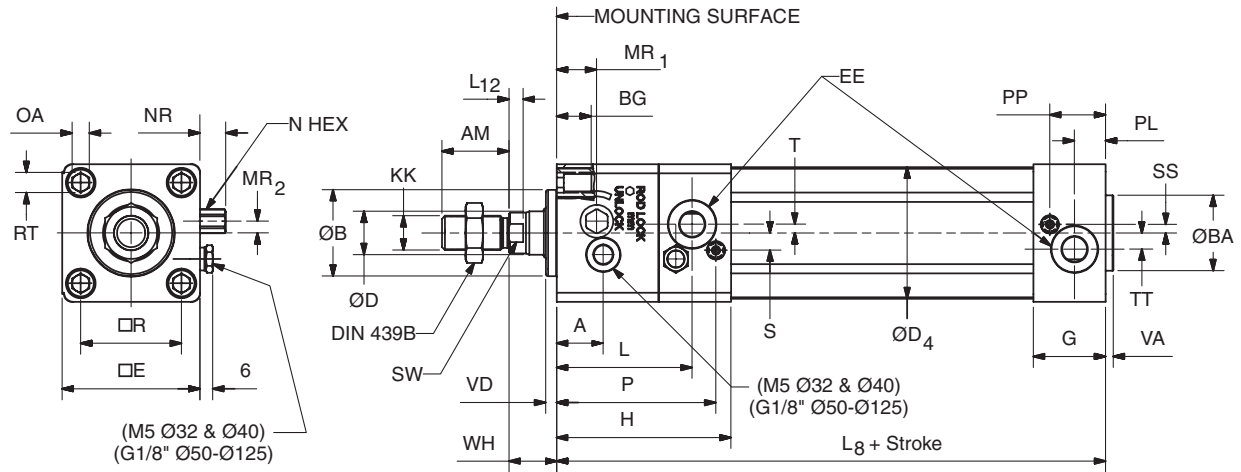
E116

**Parker Hannifin Corporation**  
 Pneumatic Division  
 Richland, Michigan  
[www.parker.com/pneumatics](http://www.parker.com/pneumatics)



Options

P1D Rod Lock Version with Manual Override (S)



Dimensions

Cylinder bore	A mm	AM mm	B mm	BA mm	BG mm	D mm	D4 mm	E mm	EE	G mm	H mm	KK	L mm	L8 mm	L12 mm	MR1 mm	MR2 mm
32	27.0	22	30	30	16	12	45.0	46.5	G1/8	28.5	71.5	M10X1.25	56.0	137	6.0	16.0	3.0
40	27.0	24	35	35	16	16	52.0	52.0	G1/4	33.0	77.0	M12X1.25	56.0	149	6.5	16.0	3.0
50	21.5	32	40	40	16	20	60.7	63.5	G1/4	33.5	80.5	M16X1.5	62.5	153	6.5	18.5	5.5
63	39.0	32	45	45	16	20	71.5	76.0	G3/8	39.5	96.5	M16X1.5	74.5	178	6.5	22.0	4.0
80	38.5	40	45	45	17	25	86.7	95.5	G3/8	39.5	110.5	M20X1.5	87.0	209	10.0	15.0	19.8
100	55.0	40	55	55	17	25	106.7	114.5	G1/2	44.5	132.5	M20X1.5	106.0	236	10.0	15.0	20.8

Cylinder bore	N mm	NR mm	OA mm	P mm	PL mm	PP mm	R mm	RT	S mm	SS mm	SW mm	T mm	TT mm	VA mm	VD mm	WH mm
32	8	10.0	6	64.8	13	21.8	32.5	M6	7	6.5	10	2.5	4.5	3.5	4.5	15
40	8	10.0	6	68.0	14	21.9	38.0	M6	9	8.0	13	2.0	5.5	3.5	4.5	16
50	10	12.0	8	73.5	14	25.9	46.5	M8	8	4.0	17	4.0	7.5	3.5	5.0	17
63	10	12.0	8	89.5	16	27.4	56.5	M8	8	6.5	17	2.0	11.0	3.5	5.0	17
80	11	12.5	6	101.5	16	30.5	72.0	M10	9	0	22	5.0	15.0	3.5	14.0	30
100	11	12.5	6	123.5	18	35.8	89.0	M10	12	0	22	6.0	20.0	3.5	14.0	30

Tolerances

Cylinder bore	B mm	R mm	L8 mm	BA mm	Stroke-length tolerance mm
32	d11	±0.5	±0.4	d11	+1/-0
40	d11	±0.5	±0.7	d11	+1/-0
50	d11	±0.6	±0.7	d11	+1/-0
63	d11	±0.7	±0.8	d11	+1/-0
80	d11	±0.7	±0.8	d11	+1/-0
100	d11	±0.7	±1.0	d11	+1/-0



Guided Cylinders

P5T Series

P5L Series

HB Series

P5E Series

XL Series



For inventory, lead time, and kit lookup, visit [www.pdnplu.com](http://www.pdnplu.com)

E117

Parker Hannifin Corporation  
Pneumatic Division  
Richland, Michigan  
[www.parker.com/pneumatics](http://www.parker.com/pneumatics)

Options

Bumpers / Adjustable Stop Collars

Bumpers absorb shock, reduce noise and permit faster cycle times, thereby increasing production rates. They can be placed on the extend, retract or both positions.

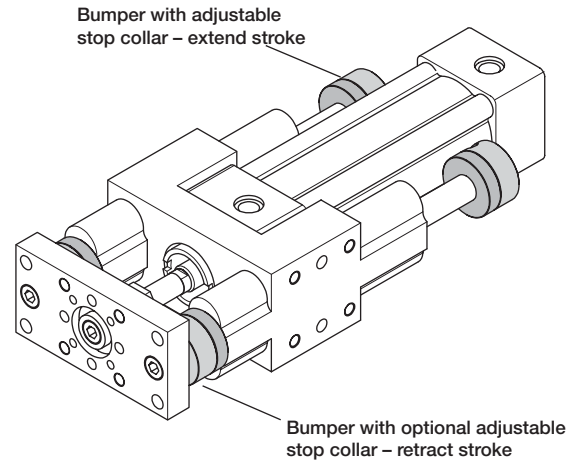
When bumpers are specified on the extend stroke, an adjustable stop collar is required and provides travel adjustment. An optional stop collar can also be specified for the retract stroke.

OPTIONS:

- B** – Bumpers (retract only)
- E** – Bumpers, adjustable stop collars (extend only)
- R** – Bumpers, adjustable stop collars (retract only)
- S** – Bumpers, adjustable stop collars (both ends)
- T** – Bumpers both ends, adjustable stop collars on extend

NOTES:

1. Bumpers and adjustable stop collars are not available with oversize shaft options.
2. To achieve the desired useable stroke length with options B, E, T, R or S, the cylinder length will increase. See Stroke Adder table for cylinder dimensions adders.
3. Bumpers and adjustable stop collars on the extend stroke require additional cylinder stroke lengths on some bore sizes in order for the collars to clear the cylinder end cap. Therefore, cushions on extend stroke are not available with this option. See Stroke Adder table for cylinder dimension adders with options E, T or S.



Bumpers and adjustable stop collars, both ends (S)

Stroke Adder for Cylinder Bumper Options

Cylinder bore	Option				
	B	T	R	S	E
32, 40, 50	5	25	25	25	25
63, 80	(0.20)	(0.98)	(0.98)	(0.98)	(0.98)
100	5	5	25	25	0
	(0.20)	(0.20)	(0.98)	(0.98)	

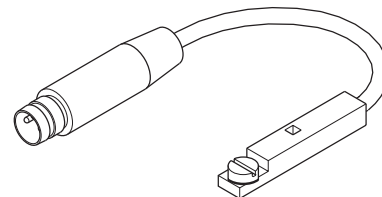
Adder dimensions in mm (inch)


**Note:** Adders not used when P1D Rod Lock (K) and P1D Manual Override Rod Lock (S) are specified with bumpers.

Sensors

Optional solid state and reed sensors sense the position of the magnetic ring on the cylinder piston. Drop-in Global Sensors are installed into the integral sensor grooves on the cylinder body and are easily positioned. Magnetic piston is standard.

Order sensors separately. See Electronic Sensors section for part numbers and specifications.



 Guided Cylinders  
 P5T Series  
 P5L Series  
 HB Series  
 P5E Series  
 XL Series



For inventory, lead times, and kit lookup, visit [www.pdnplu.com](http://www.pdnplu.com)

Options

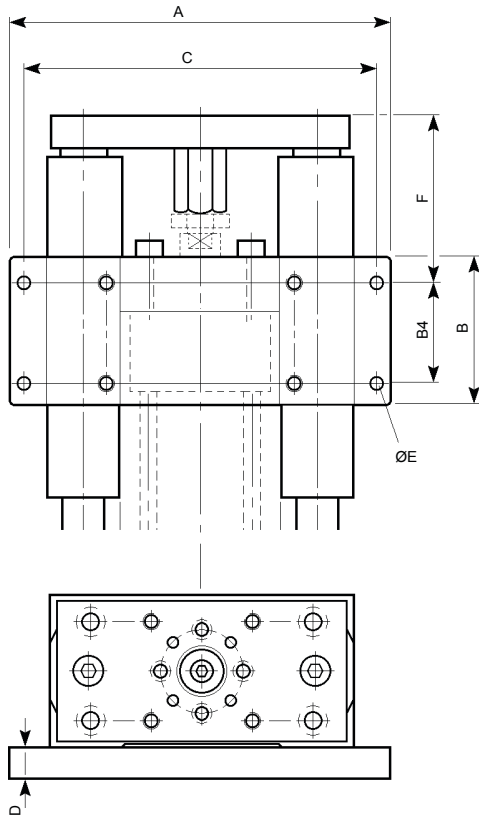
Mounting Kits

Mounting kits conform to ISO 6431, ISO/DIS 15552, VDMA 24 562 and AFNOR standards.

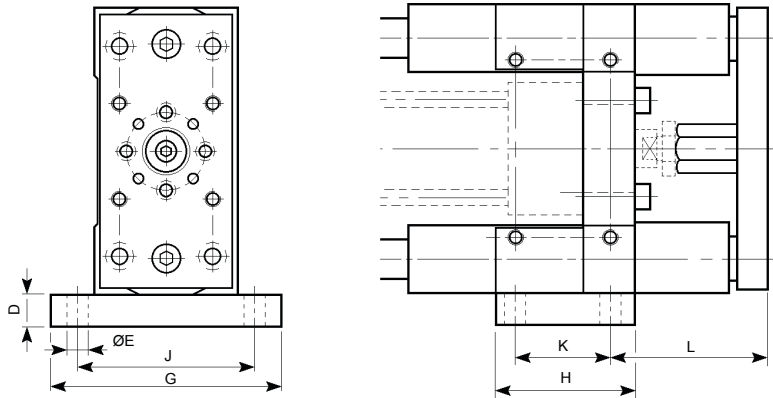
Kits include 4 mounting screws.

Raw Material: Galvanized steel

Horizontal Mounting Kit (1)



Vertical Mounting Kit (2)



Dimensions & Weights

Bore size	Mounting (1) horizontal	Mounting (2) vertical	A	B	B4	C	D	E	F	G	H	J	K	L	Weight, g (lb)	
															(1)	(2)
32	32-2801R	PIC-4KMB	128 (5.04)	50 (1.97)	32.5 (1.28)	116 (4.57)	10 (0.39)	6.6 (0.26)	60 (2.37)	80 (3.15)	47 (1.85)	64 (2.52)	32 (1.26)	60 (2.37)	500 (1.10)	230 (0.51)
40	40-2801R	PIC-4LMB	155 (6.10)	55 (2.16)	38 (1.50)	140 (5.51)	10 (0.39)	9 (0.35)	63 (2.48)	92 (3.62)	53 (2.09)	72 (2.83)	36 (1.42)	64 (2.52)	700 (1.54)	280 (0.62)
50	50-2801R	PIC-4MMB	175 (6.89)	70 (2.76)	46.5 (1.83)	160 (6.30)	12 (0.47)	9 (0.35)	70 (2.76)	113 (4.45)	65 (2.56)	90 (3.54)	45 (1.77)	71 (2.79)	1180 (2.60)	530 (1.17)
63	63-2801R	PIC-4NMB	190 (7.48)	80 (3.15)	56.5 (2.22)	175 (6.89)	12 (0.47)	9 (0.35)	74 (2.91)	129 (5.08)	74 (2.91)	100 (3.94)	50 (1.97)	77 (3.03)	1450 (3.20)	710 (1.57)
80	80-2801R	PIC-4PMB	240 (9.45)	100 (3.94)	72 (2.83)	218 (8.58)	16 (0.63)	11 (0.43)	89 (3.50)	153 (6.02)	97 (3.82)	126 (4.96)	63 (2.48)	93.5 (3.68)	3000 (6.61)	1590 (3.51)
100	100-2801R	PIC-4QMB	270 (10.63)	120 (4.72)	89 (3.50)	245 (9.65)	16 (0.63)	13 (0.51)	90.5 (3.56)	186 (6.93)	111 (4.37)	150 (5.91)	75 (2.95)	97.5 (3.84)	4100 (9.04)	2190 (4.83)

Note: All dimensions in mm or (inch) unless otherwise noted.

Guided Cylinders

P5T Series

P5L Series

HB Series

P5E Series

XL Series



For inventory, lead time, and kit lookup, visit [www.pdnplu.com](http://www.pdnplu.com)

E119

Parker Hannifin Corporation  
Pneumatic Division  
Richland, Michigan  
[www.parker.com/pneumatics](http://www.parker.com/pneumatics)

Features

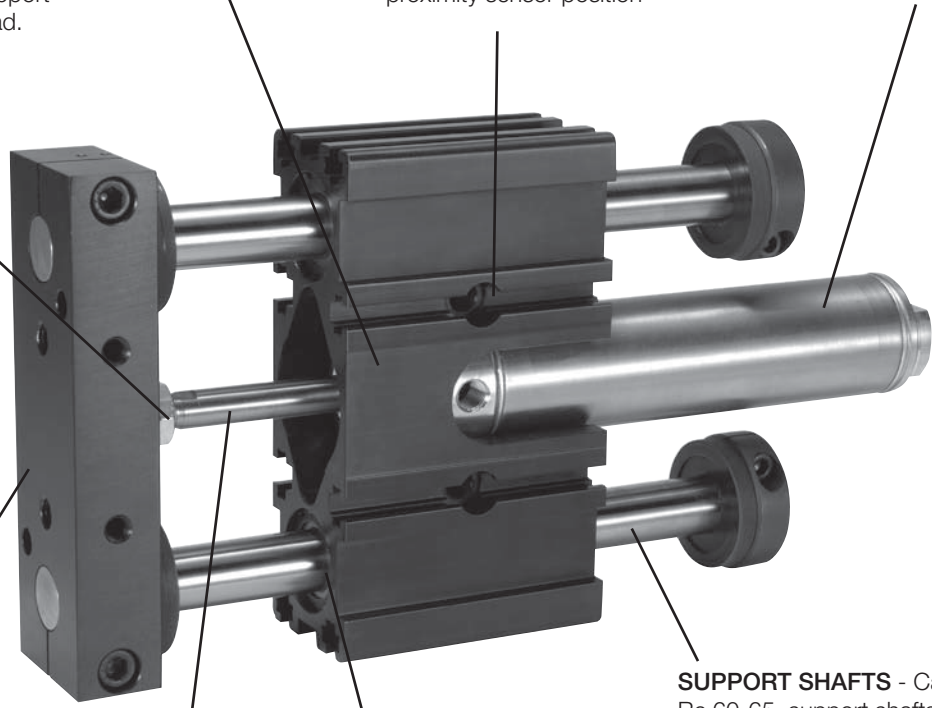
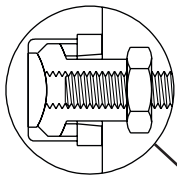
XLT and XLR Series

**LIGHTWEIGHT BODY** – A unique extruded aluminum profile reduces weight which allows for less inertia in applications requiring the body's movement

**PATENTED CYLINDER ALIGNMENT COUPLER\*** – Allows piston rod to self-center thus extending cylinder life especially when the support shafts deflect under load.

**SQUARE NUT "T" SLOTS** – Extruded into the main housing, for mounting flexibility and quick set up. One adjustment simultaneously alters stroke, shock absorber position, and proximity sensor position

**CYLINDER** – High quality Parker SRM Series stainless steel air cylinders are utilized. To minimize cylinder maintenance cost, throwaway cylinder requires no special rod extension. This shortens delivery time.



**TOOLING PLATE** – Precision machined from aluminum and then anodized, the tooling plate provides a solid surface to mount tooling or other automation components. Optional dowel pin holes allow precision mounting.

**PISTON ROD** – Manufactured from 303 stainless steel for added protection and corrosion resistance.

**BEARINGS** – Sealed recirculating ball bearings provide precise alignment with very low friction and wear. Optional composite bushings are available for high shock, washdown, and very contaminated environments.

**SUPPORT SHAFTS** - Case hardened to Rc 60-65, support shafts are machined from high carbon alloy steel. This extreme surface hardness protects the shaft's round ways from nicks and scratches - enhancing component life and reducing maintenance.

\*U.S. Patent #5,413,031

	Guided Cylinders
P5T Series	
P5L Series	
HB Series	
P5E Series	
XL Series	



For inventory, lead times, and kit lookup, visit [www.pdnplu.com](http://www.pdnplu.com)

E120

**Parker Hannifin Corporation**  
Pneumatic Division  
Richland, Michigan  
[www.parker.com/pneumatics](http://www.parker.com/pneumatics)

Features

XL Series Slide/Guided Cylinder

Designed for lighter loads, the XL Series slide provides precise, torque resistant linear motion in a very light weight, compact package. Built into the tooling plate, an alignment coupler allows the piston rod to self-center. This extends cylinder life especially when the support shafts deflect under load.

The housing is manufactured from anodized extruded aluminum incorporating "T" slots for mounting flexibility. Supported by the main body are four pre-lubricated recirculating ball bearings and two precision ground support shafts. Optional composite bushings may be specified. Outboard wiper seals protect the bearings from contamination and retain lubrication. This ensures long life with reduced maintenance. A pre-lubricated stainless steel air cylinder with

a stainless steel piston rod provides thrust while the support shafts and bearings provide positive load support for millions of non-lube, trouble-free cycles.

XL Series options include reed, Hall effect and inductive proximity sensors, prox ready, bumpers, adjustable stop collars, dowel pin holes, flow controls, Fluorocarbon seals, and 3-position cylinders. On the XLR, "T" slots support optional stroke adjusters, shock absorbers and proximity sensors. One adjustment moves all three components in unison – eliminating multiple iterations during setup.

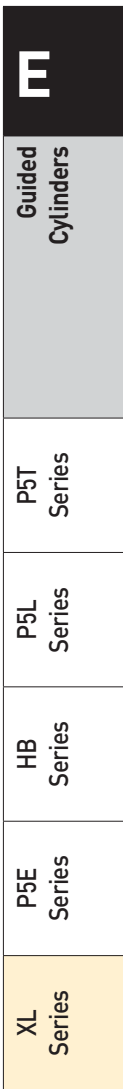
Ordering information

**XLT 08 - 06 B P L - FV - B**

<b>Series</b>	<table border="1" style="width: 100%; border-collapse: collapse;"> <tr> <td style="width: 10%;"><b>XLT</b></td> <td>XL series thrust slide</td> </tr> <tr> <td><b>XLR</b></td> <td>XL series reach slide</td> </tr> </table>	<b>XLT</b>	XL series thrust slide	<b>XLR</b>	XL series reach slide																												
<b>XLT</b>	XL series thrust slide																																
<b>XLR</b>	XL series reach slide																																
<b>Model</b>	<table border="1" style="width: 100%; border-collapse: collapse;"> <tr> <td style="width: 10%;"><b>04</b></td> <td>1/4" dia. support shaft, 9/16" dia. bore cylinder</td> </tr> <tr> <td><b>06</b></td> <td>3/8" dia. support shaft, 3/4" dia. bore cylinder</td> </tr> <tr> <td><b>08</b></td> <td>1/2" dia. support shaft, 1-1/16" dia. bore cylinder</td> </tr> <tr> <td><b>12</b></td> <td>3/4" dia. support shaft, 1-1/2" dia. bore cylinder</td> </tr> </table>	<b>04</b>	1/4" dia. support shaft, 9/16" dia. bore cylinder	<b>06</b>	3/8" dia. support shaft, 3/4" dia. bore cylinder	<b>08</b>	1/2" dia. support shaft, 1-1/16" dia. bore cylinder	<b>12</b>	3/4" dia. support shaft, 1-1/2" dia. bore cylinder																								
<b>04</b>	1/4" dia. support shaft, 9/16" dia. bore cylinder																																
<b>06</b>	3/8" dia. support shaft, 3/4" dia. bore cylinder																																
<b>08</b>	1/2" dia. support shaft, 1-1/16" dia. bore cylinder																																
<b>12</b>	3/4" dia. support shaft, 1-1/2" dia. bore cylinder																																
<b>Slide orientation</b>	<table border="1" style="width: 100%; border-collapse: collapse;"> <tr> <td style="width: 10%;"><b>Omit</b></td> <td>Standard</td> </tr> <tr> <td><b>L</b></td> <td>Left hand assembly</td> </tr> </table>	<b>Omit</b>	Standard	<b>L</b>	Left hand assembly																												
<b>Omit</b>	Standard																																
<b>L</b>	Left hand assembly																																
<b>Special options / modifications</b>	<table border="1" style="width: 100%; border-collapse: collapse;"> <tr> <td style="width: 10%;"><b>Omit</b></td> <td>Standard unit</td> </tr> <tr> <td colspan="2">(Two digit code assigned by factory when any "X" appears in the model number or when special options or features are required.)</td> </tr> </table>	<b>Omit</b>	Standard unit	(Two digit code assigned by factory when any "X" appears in the model number or when special options or features are required.)																													
<b>Omit</b>	Standard unit																																
(Two digit code assigned by factory when any "X" appears in the model number or when special options or features are required.)																																	
<b>Design series</b>	<table border="1" style="width: 100%; border-collapse: collapse;"> <tr> <td style="width: 10%;"><b>B</b></td> <td>Current</td> </tr> </table>	<b>B</b>	Current																														
<b>B</b>	Current																																
<b>Stroke length (inch)</b>	Order in 1" increments. See quick reference table on next page for maximum stroke lengths. For three position units, specify intermediate and total stroke separated by a "/", ie 02/06.																																
<b>Slide configuration options</b>	<table border="1" style="width: 100%; border-collapse: collapse;"> <tr> <td style="width: 10%;"><b>Omit</b></td> <td>None</td> </tr> <tr> <td colspan="2"><b>XLR only</b></td> </tr> <tr> <td><b>A</b></td> <td>Shock / stroke adjust, both ends</td> </tr> <tr> <td><b>A1</b></td> <td>Shock / stroke adjust, extend only</td> </tr> <tr> <td><b>A2</b></td> <td>Shock / stroke adjust, retract only</td> </tr> <tr> <td><b>A3</b></td> <td>Shock ready, both ends</td> </tr> <tr> <td><b>A4</b></td> <td>Shock ready, extend only</td> </tr> <tr> <td><b>A5</b></td> <td>Shock ready, retract only</td> </tr> <tr> <td colspan="2"><b>XLT &amp; XLR Bumper / cushions options</b></td> </tr> <tr> <td><b>B</b></td> <td>Bumpers, both ends <sup>1,4</sup></td> </tr> <tr> <td><b>B1</b></td> <td>Bumpers, extend only <sup>1,4</sup></td> </tr> <tr> <td><b>B2</b></td> <td>Bumpers, retract only <sup>4</sup></td> </tr> <tr> <td><b>B3</b></td> <td>Bumpers, adjustable stop collar, retract only <sup>4</sup></td> </tr> <tr> <td><b>B4</b></td> <td>Bumpers, adjustable stop collar, both ends <sup>4</sup></td> </tr> <tr> <td><b>C</b></td> <td>Cushions on cylinder, both ends</td> </tr> <tr> <td><b>X</b></td> <td>Special (detail in clear text)</td> </tr> </table>	<b>Omit</b>	None	<b>XLR only</b>		<b>A</b>	Shock / stroke adjust, both ends	<b>A1</b>	Shock / stroke adjust, extend only	<b>A2</b>	Shock / stroke adjust, retract only	<b>A3</b>	Shock ready, both ends	<b>A4</b>	Shock ready, extend only	<b>A5</b>	Shock ready, retract only	<b>XLT &amp; XLR Bumper / cushions options</b>		<b>B</b>	Bumpers, both ends <sup>1,4</sup>	<b>B1</b>	Bumpers, extend only <sup>1,4</sup>	<b>B2</b>	Bumpers, retract only <sup>4</sup>	<b>B3</b>	Bumpers, adjustable stop collar, retract only <sup>4</sup>	<b>B4</b>	Bumpers, adjustable stop collar, both ends <sup>4</sup>	<b>C</b>	Cushions on cylinder, both ends	<b>X</b>	Special (detail in clear text)
<b>Omit</b>	None																																
<b>XLR only</b>																																	
<b>A</b>	Shock / stroke adjust, both ends																																
<b>A1</b>	Shock / stroke adjust, extend only																																
<b>A2</b>	Shock / stroke adjust, retract only																																
<b>A3</b>	Shock ready, both ends																																
<b>A4</b>	Shock ready, extend only																																
<b>A5</b>	Shock ready, retract only																																
<b>XLT &amp; XLR Bumper / cushions options</b>																																	
<b>B</b>	Bumpers, both ends <sup>1,4</sup>																																
<b>B1</b>	Bumpers, extend only <sup>1,4</sup>																																
<b>B2</b>	Bumpers, retract only <sup>4</sup>																																
<b>B3</b>	Bumpers, adjustable stop collar, retract only <sup>4</sup>																																
<b>B4</b>	Bumpers, adjustable stop collar, both ends <sup>4</sup>																																
<b>C</b>	Cushions on cylinder, both ends																																
<b>X</b>	Special (detail in clear text)																																
<b>Other options</b> (More than one selection is possible)	<table border="1" style="width: 100%; border-collapse: collapse;"> <tr> <td style="width: 10%;"><b>Omit</b></td> <td>None</td> </tr> <tr> <td><b>D</b></td> <td>Bumpers on cylinder only</td> </tr> <tr> <td><b>E</b></td> <td>Dowel pin holes</td> </tr> <tr> <td><b>F</b></td> <td>Flow controls (Prestolok)</td> </tr> <tr> <td><b>G</b></td> <td>Flow controls <sup>3</sup></td> </tr> <tr> <td><b>K</b></td> <td>Stainless steel support shafts</td> </tr> <tr> <td><b>T</b></td> <td>Composite bushings</td> </tr> <tr> <td><b>V</b></td> <td>Fluorocarbon piston seals</td> </tr> <tr> <td><b>X</b></td> <td>Special (detail in clear text)</td> </tr> </table>	<b>Omit</b>	None	<b>D</b>	Bumpers on cylinder only	<b>E</b>	Dowel pin holes	<b>F</b>	Flow controls (Prestolok)	<b>G</b>	Flow controls <sup>3</sup>	<b>K</b>	Stainless steel support shafts	<b>T</b>	Composite bushings	<b>V</b>	Fluorocarbon piston seals	<b>X</b>	Special (detail in clear text)														
<b>Omit</b>	None																																
<b>D</b>	Bumpers on cylinder only																																
<b>E</b>	Dowel pin holes																																
<b>F</b>	Flow controls (Prestolok)																																
<b>G</b>	Flow controls <sup>3</sup>																																
<b>K</b>	Stainless steel support shafts																																
<b>T</b>	Composite bushings																																
<b>V</b>	Fluorocarbon piston seals																																
<b>X</b>	Special (detail in clear text)																																
<b>Slide proximity sensor options</b>	<table border="1" style="width: 100%; border-collapse: collapse;"> <tr> <td style="width: 10%;"><b>Omit</b></td> <td>None</td> </tr> <tr> <td><b>P</b></td> <td>PNP lead type</td> </tr> <tr> <td><b>N</b></td> <td>NPN lead type</td> </tr> <tr> <td><b>P1</b></td> <td>PNP, plug in leads</td> </tr> <tr> <td><b>N1</b></td> <td>NPN, plug in leads</td> </tr> <tr> <td><b>J</b></td> <td>Prox ready, 8mm (no sensors supplied)</td> </tr> <tr> <td><b>J1</b></td> <td>Prox ready, 12mm (no sensors supplied) <sup>2</sup></td> </tr> </table> <p><b>Note:</b> Inductive proximity sensors are included with the P, N, P1 &amp; N1 options. Order Reed and Hall Effect switches separately. See chart on next page. Piston magnet is provided as standard.</p>	<b>Omit</b>	None	<b>P</b>	PNP lead type	<b>N</b>	NPN lead type	<b>P1</b>	PNP, plug in leads	<b>N1</b>	NPN, plug in leads	<b>J</b>	Prox ready, 8mm (no sensors supplied)	<b>J1</b>	Prox ready, 12mm (no sensors supplied) <sup>2</sup>																		
<b>Omit</b>	None																																
<b>P</b>	PNP lead type																																
<b>N</b>	NPN lead type																																
<b>P1</b>	PNP, plug in leads																																
<b>N1</b>	NPN, plug in leads																																
<b>J</b>	Prox ready, 8mm (no sensors supplied)																																
<b>J1</b>	Prox ready, 12mm (no sensors supplied) <sup>2</sup>																																

**NOTES:**

- <sup>1</sup> Adjustable stop collar is standard on extend.
- <sup>2</sup> Not available on Model 04 and 06.
- <sup>3</sup> Not available on Model 04.
- <sup>4</sup> Bumpers on cylinder are included with all "B" options at no extra charge.



For inventory, lead time, and kit lookup, visit [www.pdnplu.com](http://www.pdnplu.com)

E121

**Parker Hannifin Corporation**  
Pneumatic Division  
Richland, Michigan  
[www.parker.com/pneumatics](http://www.parker.com/pneumatics)

**General Specifications**

**Specifications**

- Maximum operating pressure: 100 psi
- Operating characteristics:  
 double acting standard (single acting available)
- Four support shaft sizes: 1/4", 3/8", 1/2" and 3/4"
- Stroke tolerance: +.060, -.000
- Mounting: unrestricted
- Operating temperature range (cylinder):  
 Standard seals 0 to 165°F  
 Fluorocarbon seals\* 0 to 250°F
- Filtration requirement: 40 micron filtered, dry air

\* See fluorocarbon seal option for high temperature applications.

**Quick Reference Data**


Series	Model	Support rod diameter (in)	Cylinder bore size (in)	Maximum stroke (in)	Force output on extension at 80 psi (lb)	Force output on retraction at 80 psi (lb)	Unit weight (lb)	
							Base	Per inch
XLT	04	1/4	9/16	6	20	18	0.65	0.052
	06	3/8	3/4	12	35	31	1.25	0.098
	08	1/2	1-1/16	14	70	64	2.55	0.163
	12	3/4	1-1/2	18	140	128	6.10	0.335
XLR	04	1/4	9/16	8	20	18	0.90	0.052
	06	3/8	3/4	16	35	31	1.80	0.098
	08	1/2	1-1/16	18	70	64	3.55	0.163
	12	3/4	1-1/2	24	140	128	8.00	0.335

**Switches**

Description	Part number
PNP Hall Effect w/6" male plug-in connector	<b>146715000C</b>
NPN Hall Effect w/6" male plug-in connector	<b>146714000C</b>
PNP Hall Effect w/39" potted-in leads	<b>1467150000</b>
NPN Hall Effect w/39" potted-in leads	<b>1467140000</b>
Reed switch w/6" male plug-in connector	<b>145903000C</b>
Reed switch w/39" potted-in leads	<b>1459030000</b>

**Clamps**

Model	Part number
04	<b>L074730056</b>
06	<b>L074730075</b>
08	<b>L074730106</b>
12	<b>L074730150</b>


**Guided Cylinders**  
 P5T Series  
 P5L Series  
 HB Series  
 P5E Series  
 XL Series



For inventory, lead times, and kit lookup, visit [www.pdnplu.com](http://www.pdnplu.com)

E122

**Parker Hannifin Corporation**  
 Pneumatic Division  
 Richland, Michigan  
[www.parker.com/pneumatics](http://www.parker.com/pneumatics)

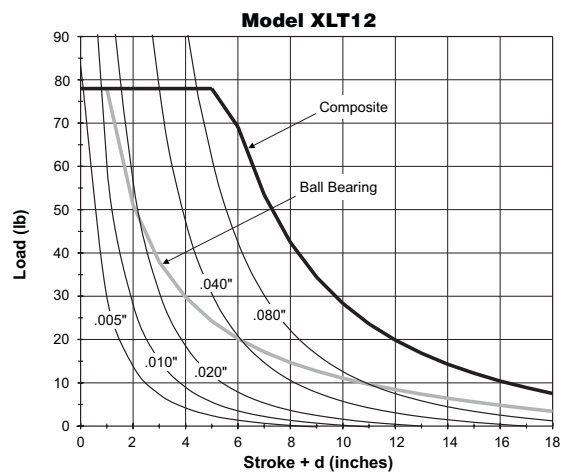
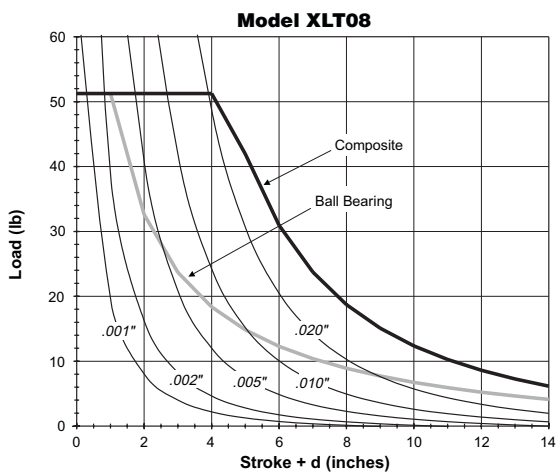
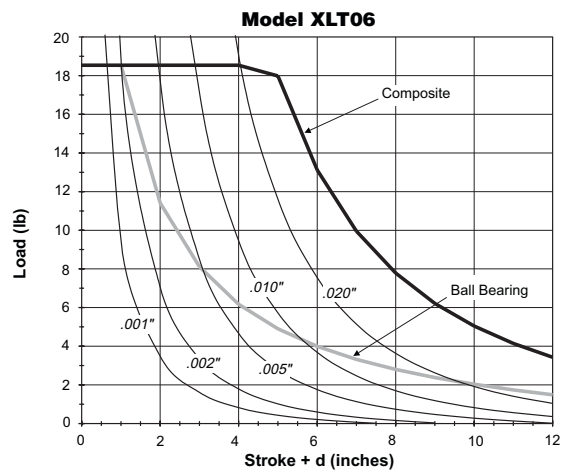
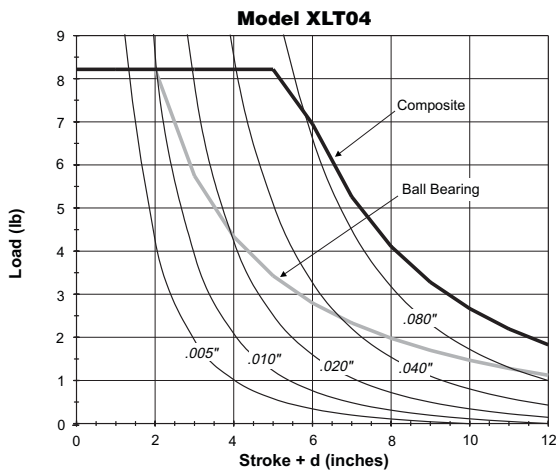
**Dynamic Horizontal Load Capacity and Deflection vs. Stroke**

The plots on this page illustrate the side load vs. actuator stroke for the XLT Series slides. The XLR Series is shown on the following page. Applied loads will cause a slight deflection of the support rods. Deflection distance is also shown. The graphs include the weight of the support rods and tooling plate and are based on a bearing life equivalent to 10 million inches of travel for dynamic conditions. Higher dynamic loads will reduce cycle life. For static loads, multiply the information in the graph by 1.5.

**NOTE:** Actuator life may vary depending on the severity of the following variables:

- Acceleration
- Velocity
- Vibration
- Orientation

**XLT Series**

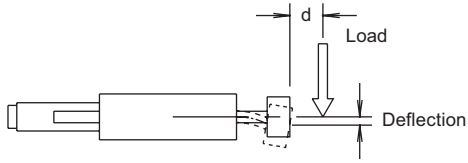


<b>P</b>
Guided Cylinders
P5T Series
P5L Series
HB Series
P5E Series
XL Series



For inventory, lead time, and kit lookup, visit [www.pdnplu.com](http://www.pdnplu.com)

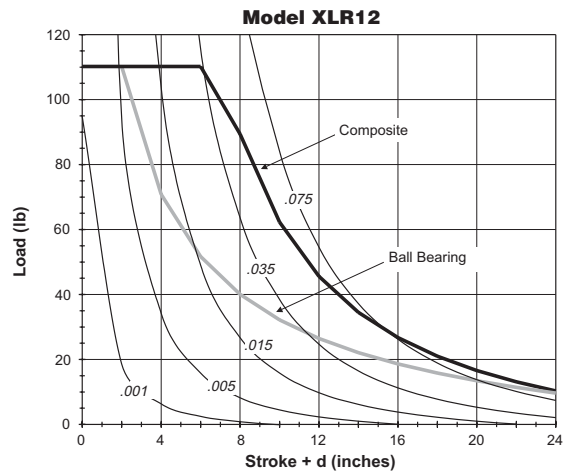
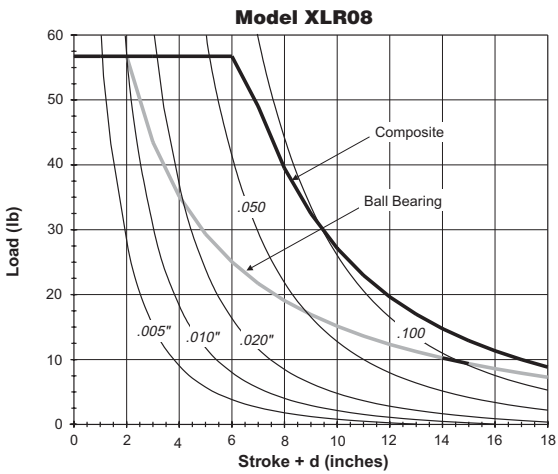
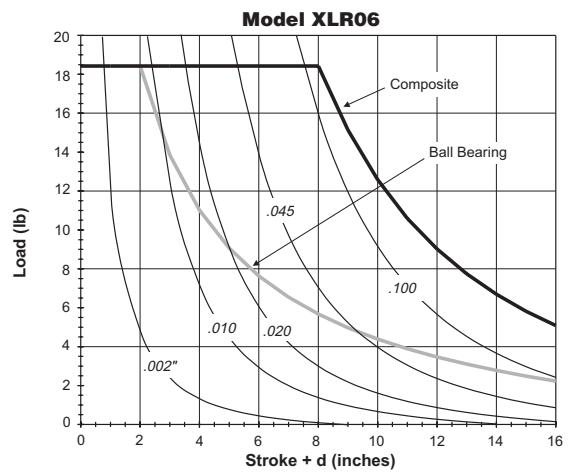
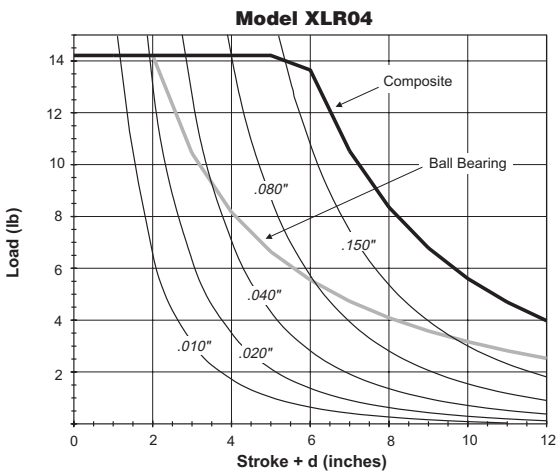
**Dynamic Horizontal Load Capacity and Deflection vs. Stroke**



**EXAMPLE:**  
 An XLR04 with ball bushings and a "stroke+d" of 8" would have a load capacity of 4 lbs.

**XLR Series**

 <b>Guided Cylinders</b>	P5T Series
	P5L Series
	HB Series
	P5E Series
	XL Series





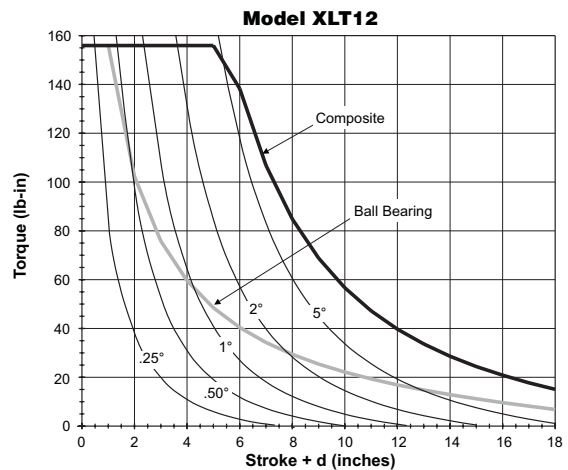
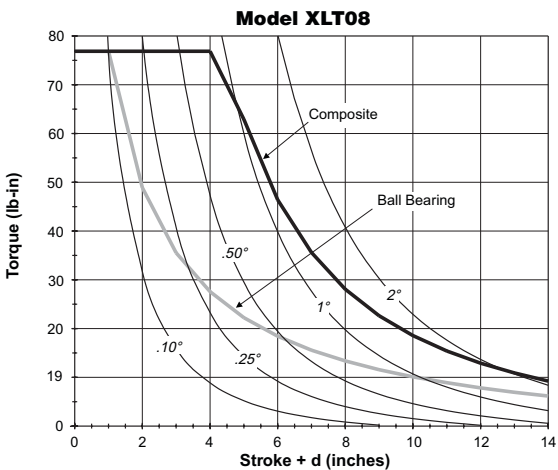
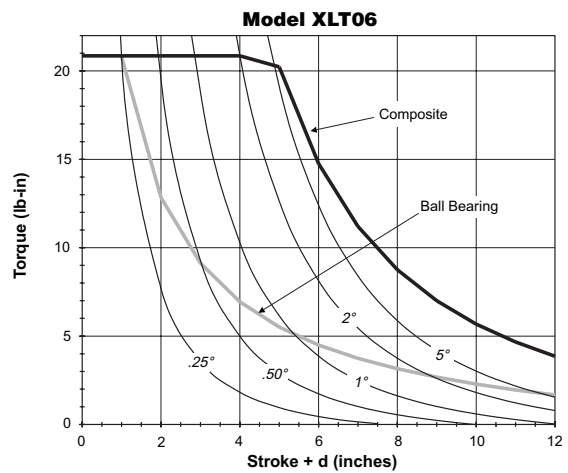
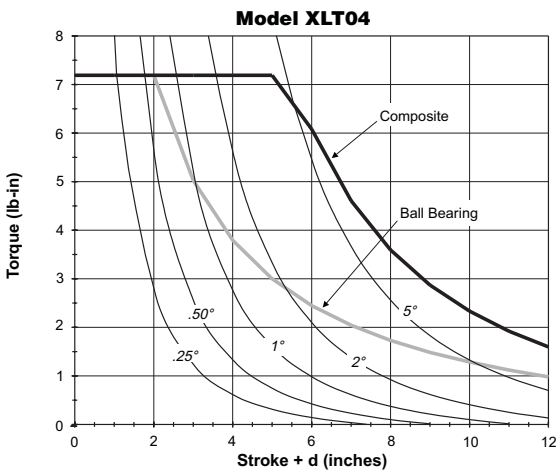
**Symmetrical Torque Capacity**

The plots on these two pages provide the torsional load vs. actuator stroke for various slide sizes. The XLT Series is shown on this page; the XLR Series is shown on the following page. Torsional loads will cause a slight amount of angular deflection of the tooling plate. Angular deflection is also shown. The data presented is based on a bearing life equivalent to 10 million inches of travel for dynamic conditions. Higher dynamic torques will reduce cycle life. For static torque, multiply the information in the graph by 1.5.

**NOTE:** Actuator life may vary depending on the severity of the following variables:

- Acceleration
- Velocity
- Vibration
- Orientation

**XLT Series**

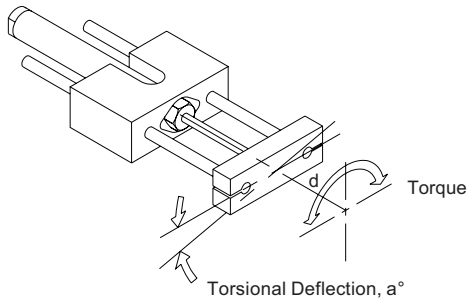


<b>P</b>
Guided Cylinders
P5T Series
P5L Series
HB Series
P5E Series
XL Series



For inventory, lead time, and kit lookup, visit [www.pdnplu.com](http://www.pdnplu.com)

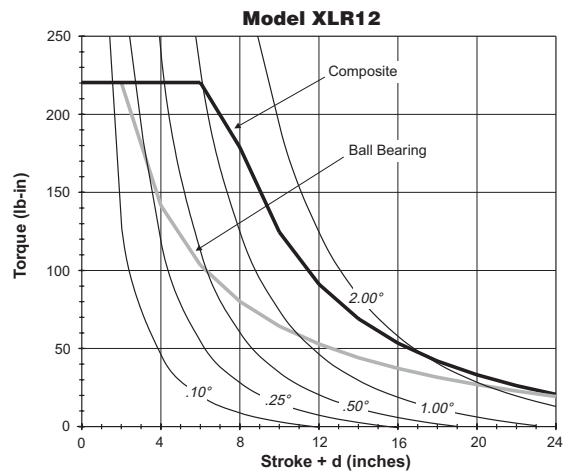
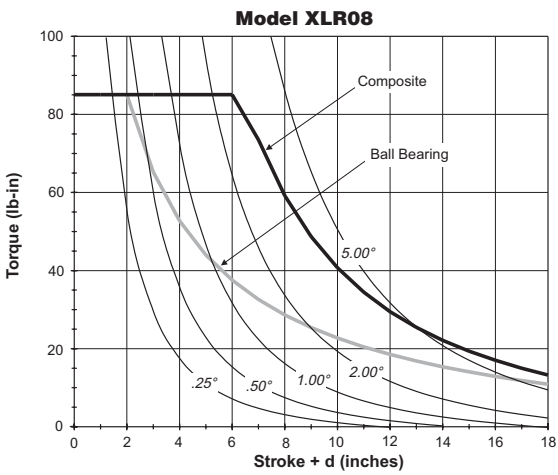
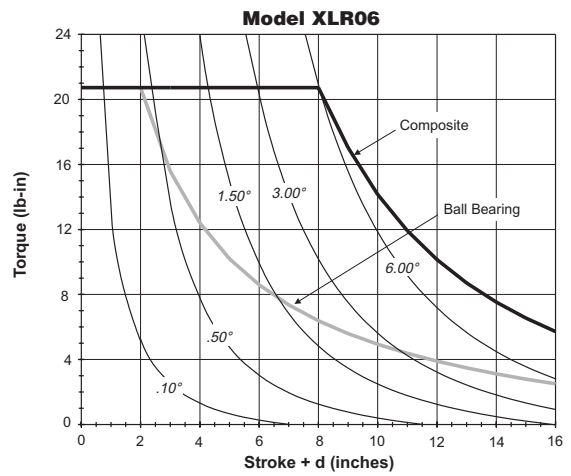
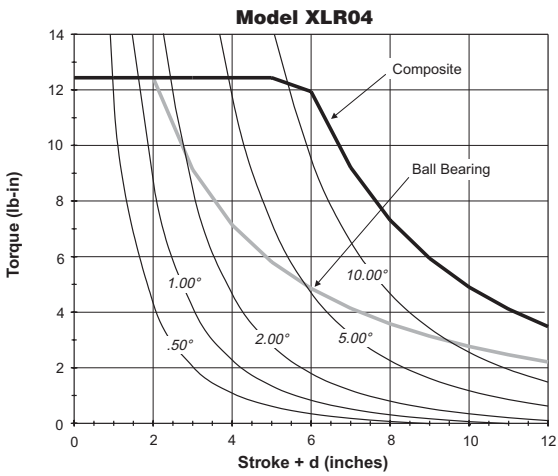
**Symmetrical Torque Capacity**



**EXAMPLE:**  
 An XLR08 with composite bushings and a stroke + d of 10" would have a torque capacity of 40 lb-in.

**XLR Series**

<b>U</b>	Guided Cylinders
P5T Series	
P5L Series	
HB Series	
P5E Series	
XL Series	



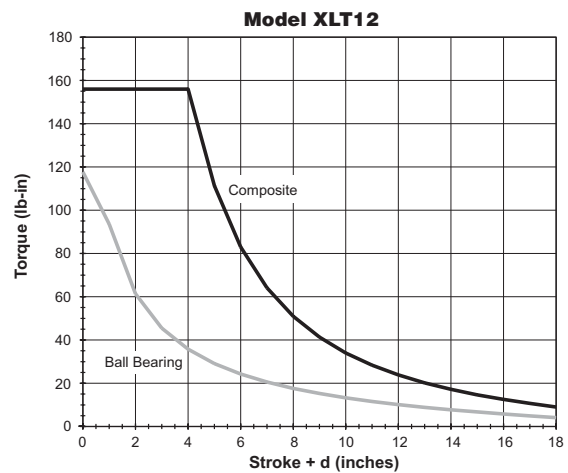
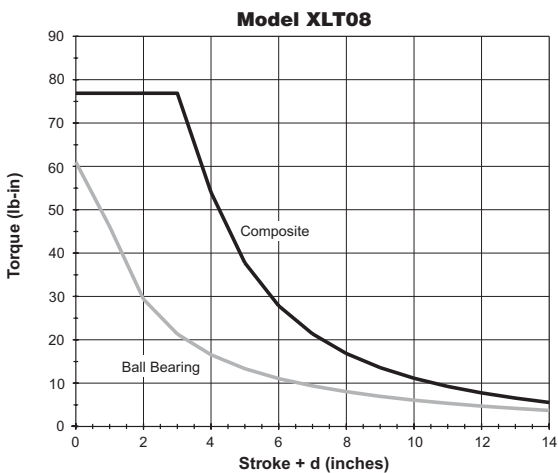
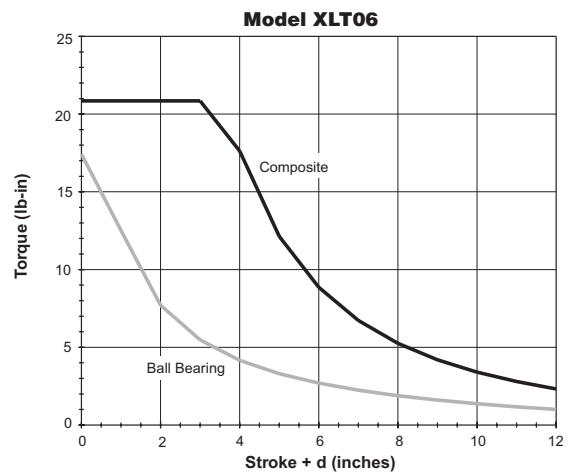
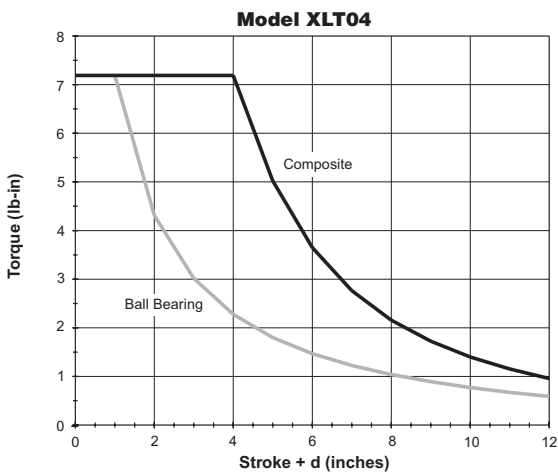
**Asymmetrical Torque Capacity**

Asymmetrical loading occurs when the load is applied to one side of the unit. XL Series units can resist torsional loads that are asymmetrical. The graphs on these two pages show torsional load capacity for both composite bushings and ball bearings. The XLT Series is shown on this page; the XLR Series is shown on the following page.

**NOTE:** Actuator life may vary depending on the severity of the following variables:

- Acceleration
- Velocity
- Vibration
- Orientation

**XLT Series**

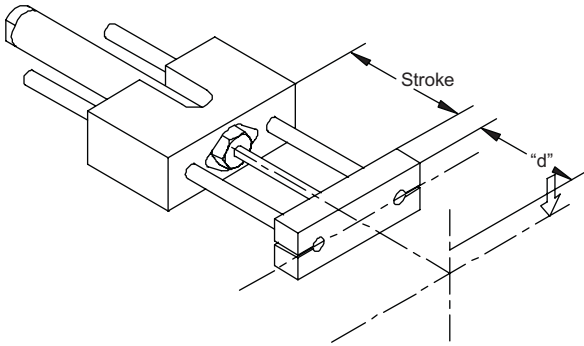


<b>M</b>
Guided Cylinders
P5T Series
P5L Series
HB Series
P5E Series
XL Series



For inventory, lead time, and kit lookup, visit [www.pdnplu.com](http://www.pdnplu.com)

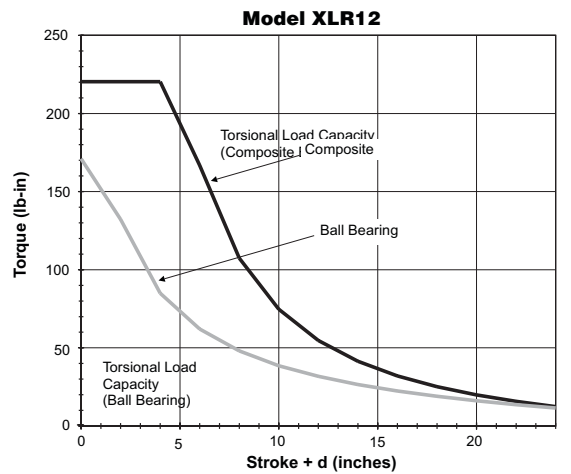
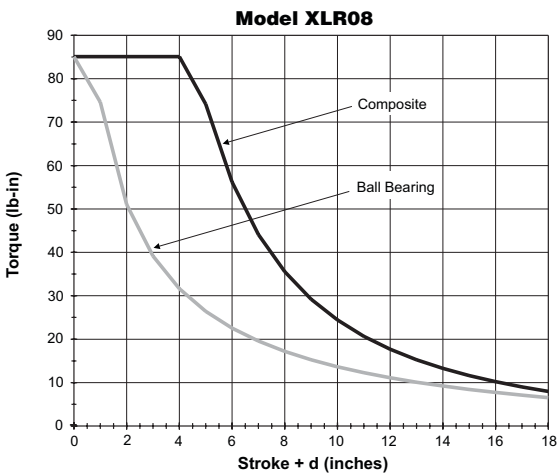
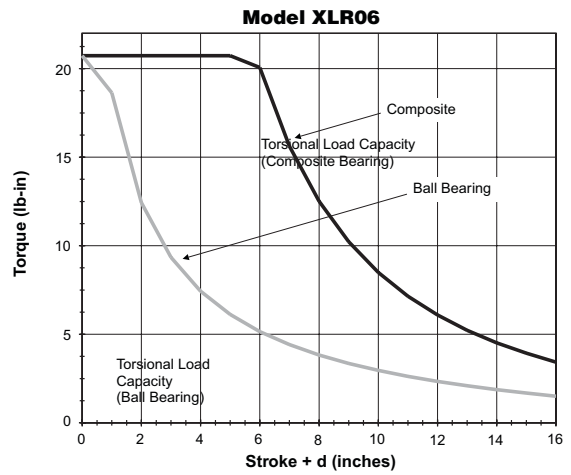
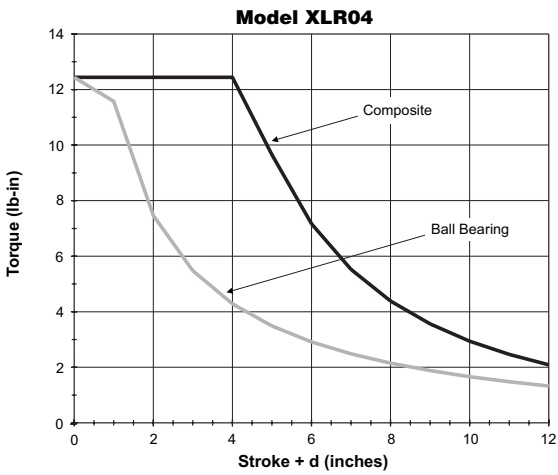
**Asymmetrical Torque Capacity**



**EXAMPLE:**  
 An XLT12 with ball bearings and a stroke + d of 2" would have an asymmetrical torsional load capacity of 60 lb-in.

**XLR Series**

<b>U</b>	Guided Cylinders
P5T Series	
P5L Series	
HB Series	
P5E Series	
XL Series	



For inventory, lead times, and kit lookup, visit [www.pdnplu.com](http://www.pdnplu.com)

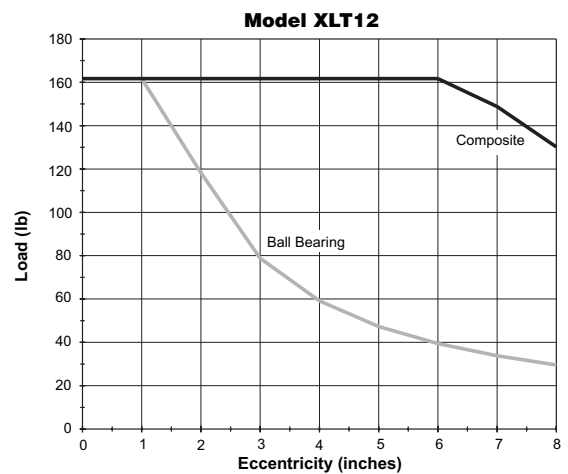
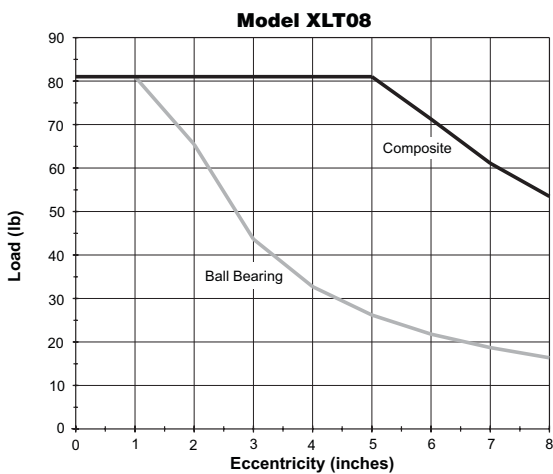
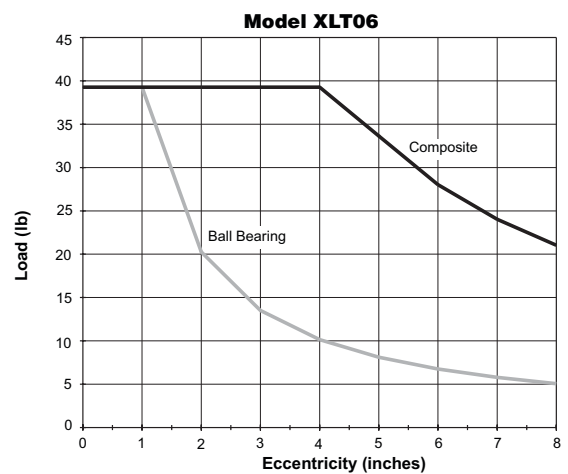
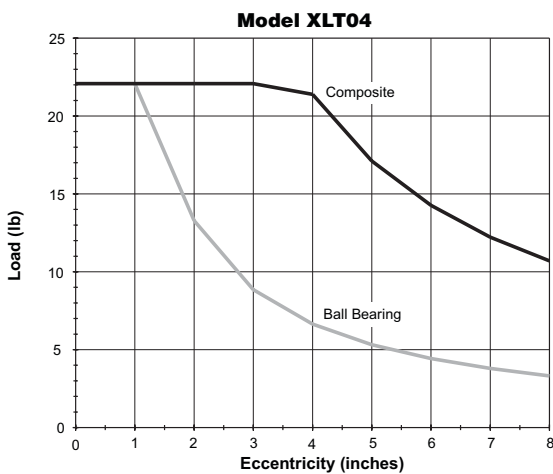
**Vertical Load Capacity and Allowable**

XL Series units mounted vertically will have the same eccentric load capacity regardless of orientation. The graphs provide maximum load capacity for an eccentric mounted load. The load is assumed to be mounted at the face of the tooling plate. The XLT Series is shown on this page; the XLR Series is shown on the following page.

**NOTE:** Actuator life may vary depending on the severity of the following variables:

- Acceleration
- Velocity
- Vibration

**XLT Series**

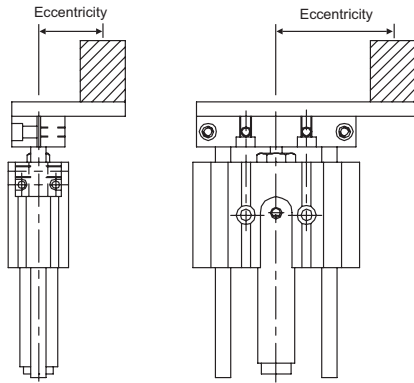


<b>M</b>
Guided Cylinders
P5T Series
P5L Series
HB Series
P5E Series
XL Series



For inventory, lead time, and kit lookup, visit [www.pdnplu.com](http://www.pdnplu.com)

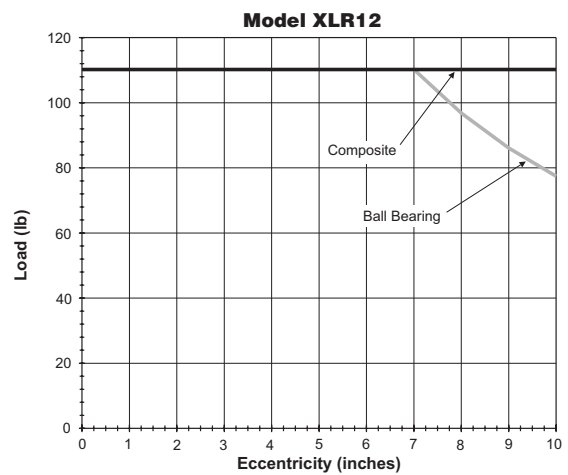
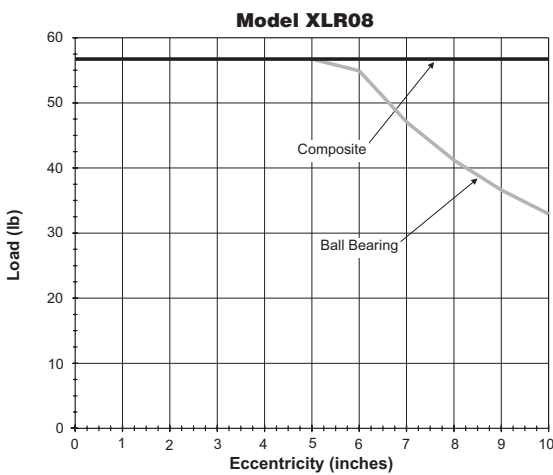
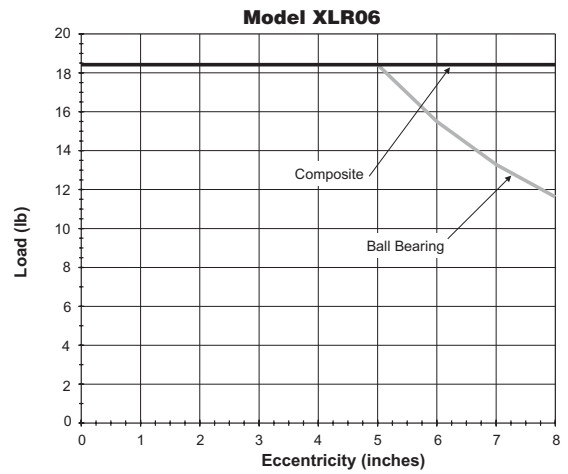
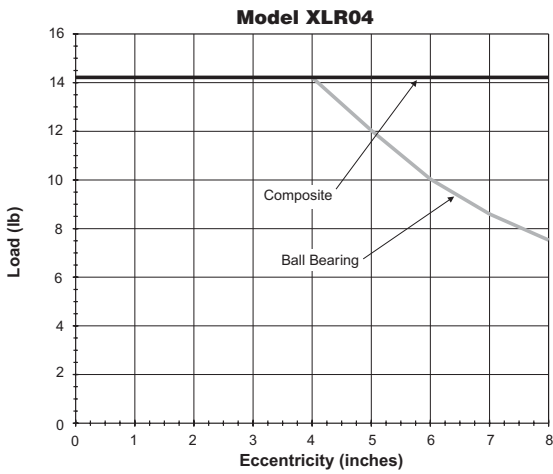
**Vertical Load Capacity and Allowable**



**EXAMPLE:**  
 An XLR06 with ball bearings and eccentric distance of 7" would carry a load of 13 lbs.

**XLR Series**

<b>U</b>	Guided Cylinders
P5T Series	
P5L Series	
HB Series	
P5E Series	
XL Series	

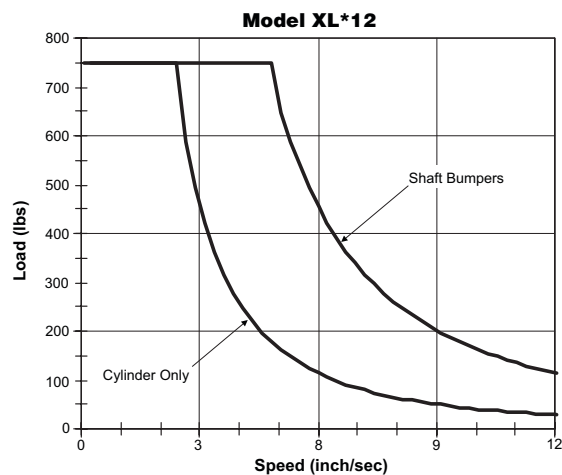
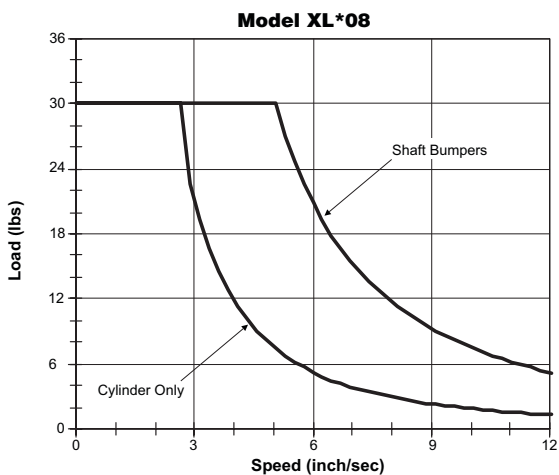
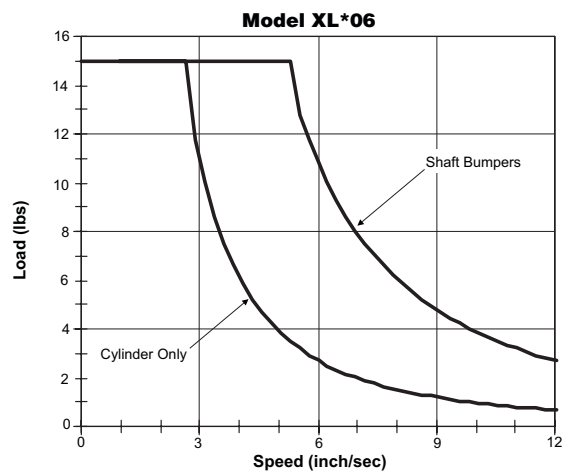
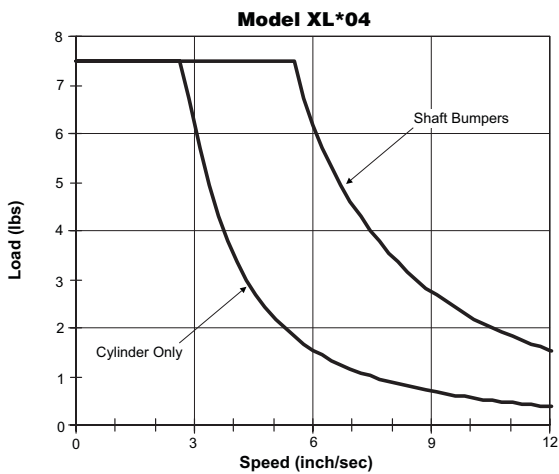


For inventory, lead times, and kit lookup, visit [www.pdnplu.com](http://www.pdnplu.com)

**Kinetic Energy**

These plots illustrate the stopping capacity of the XL Series with bumpers or cylinder only. This type of sizing is based on the weight of the load and the speed at which the load is moving. The bumper plots are based on a 0.020" deflection. For values above the cushion line, shock absorbers must be specified. Follow the shock absorber sizing steps on the following page to ensure proper stopping capacity. Shocks available on XLR only.

**NOTE:** These charts are to be used only to determine the stopping capacity of each guided cylinder.



<b>M</b>
Guided Cylinders
P5T Series
P5L Series
HB Series
P5E Series
XL Series



For inventory, lead time, and kit lookup, visit [www.pdnplu.com](http://www.pdnplu.com)

**Kinetic Energy**

**Steps to sizing a guided cylinder with shocks (XLR only):**

- 1) Determine the "Moving Weight", W.  
 Use Table 1 to determine the "Kinetic Energy Weight" of a given slide. This value should be added to the weight of the load the slide will be carrying.

$$\text{Moving Weight (lbs)} = \text{Kinetic Energy Weight (lbs)} + \text{Weight of Load (lbs)}$$

- 2) Determine the velocity of the load, V (in/second)
- 3) Determine the cylinder force output at the operating pressure, F<sub>cylinder</sub> (lbs)
- 4) Determine the Kinetic Energy of the load:  
 $KE = 0.2 \times W \times V^2$  (lb-in)

- 5) Determine the Energy per Cycle, E<sub>cycle</sub> (lb-in):  
 $E_{\text{cycle}} = KE + F_{\text{cylinder}} \times \text{Shock Stroke}$   
 (unless stroke adjusters are used, 1 inch is standard)  
*This value should be less than the value listed in table 2*

- 6) Determine the Energy per Hour: E<sub>hour</sub> (in-lbs)  
 $E_{\text{hour}} = 2 \times E_{\text{cycle}} \times \# \text{ of cycles in one hour}$   
 (a cycle is defined as the extension and retraction of the slide)  
*This value should be less than the value listed in table 2*

- 7) Determine the Effective Weight of the load  
 $W_{\text{effective}} = \frac{E_{\text{cycle}}}{0.2 \times V^2}$   
*This value should be between the values listed in table 2*

**Example:**

An XLR12-15A-B with be carrying a load of 15 lbs at a velocity of 30 in/second (cycling 20 times per hour) while operating at 50 psi. Is this unit properly sized?

- 1) Moving Weight =  $[4.66 + (15 \times 0.29)] + 15 \text{ lbs} = 24.01 \text{ lbs}$
- 2)  $V = 30 \text{ in/second} = 2.5 \text{ ft/second}$
- 3)  $F_{\text{cylinder}} = 87.5 \times 0.75 = 65.6 \text{ lbs}$
- 4)  $KE = 0.2 \times 24.01 \times 2.5^2 = 30 \text{ lb-in}$
- 5)  $E_{\text{cycle}} = 30 + 65.6 = 95.6 \text{ lb-in}$
- 6)  $E_{\text{hour}} = 2 \times 95.6 \times 20 = 3824 \text{ lb-in}$
- 7)  $W_{\text{effective}} = \frac{95.6}{0.2 \times (2.5)^2} = 695 \text{ lbs}$


The shock will dissipate the energy of the load.

**Table 1**

Model	Base weight (lb)	Stroke adder (lb/inch)
XLR04	0.42	0.04
XLR06	0.92	0.08
XLR08	1.80	0.13
XLR12	4.66	0.29

**Table 2**

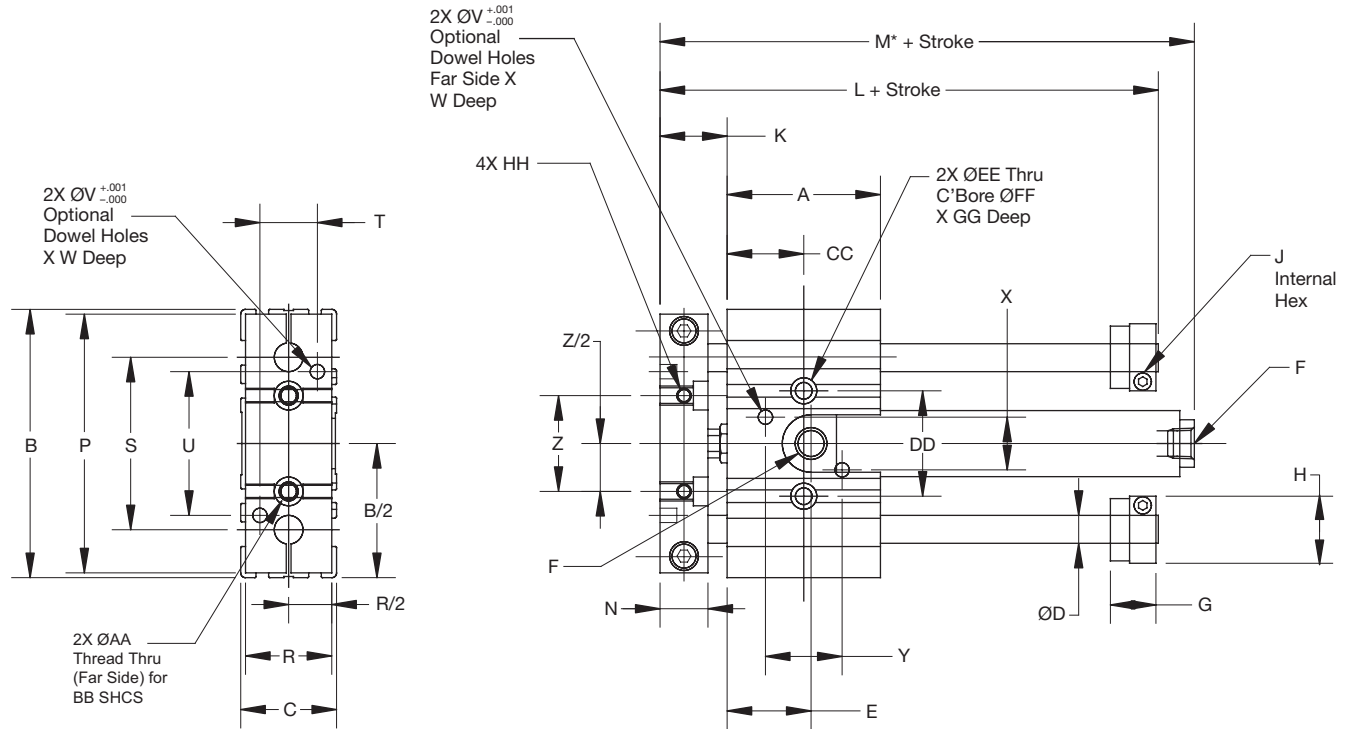
Size	Total energy per cycle (lb-in)	Total energy per hour (lb-in)	Effective weight (lb)	Velocity range (in/sec)
04	20	120,000	1.5 - 5	6 - 96
06	45	125,000	1.5 - 14	6 - 120
08	150	300,000	2 - 22	6 - 144
12	300	400,000	50 - 150	6 - 144


**Guided Cylinders**  
 P5T Series  
 P5L Series  
 HB Series  
 P5E Series  
 XL Series





**XLT Series**



**XLT Basic Dimensions**

Model	A	B	C	D	E	F	G	H	J	K	L	M*	M1	N	P	R
XLT04	1.75	2.75	1.00	.250	.84	#10-32	.55	.63	3/32	.75	3.13	3.08	3.24	.50	2.63	.88
XLT06	2.00	3.50	1.25	.375	1.09	1/8 NPTF	.61	.88	7/64	.88	3.56	3.98	4.23	.63	3.38	1.13
XLT08	2.75	4.50	1.50	.500	1.38	1/8 NPTF	.67	1.13	9/64	1.00	4.50	4.60	4.85	.75	4.38	1.38
XLT12	3.50	6.00	2.00	.750	1.75	1/8 NPTF	.77	1.75	3/16	1.25	5.63	5.44	5.69	1.00	5.88	1.88

Model	S	T	U	V	W	X	Y	Z	AA	BB	CC	DD	EE	FF	GG	HH
XLT04	1.750	.500	1.500	.126	.19	.438	1.000	1.000	#10-32	#6	.875	1.000	.19	.31	.25	#8-32
XLT06	2.250	.750	1.875	.188	.22	.688	1.000	1.250	1/4-20	#10	1.000	1.375	.22	.38	.38	#10-32
XLT08	3.000	.750	2.250	.251	.25	.938	1.500	1.500	5/16-18	1/4	1.375	1.750	.28	.44	.38	1/4-20
XLT12	4.000	1.25	3.000	.313	.32	1.250	2.000	2.000	3/8-16	5/16	1.750	2.250	.34	.53	.50	5/16-18

All dimensions shown in inches.



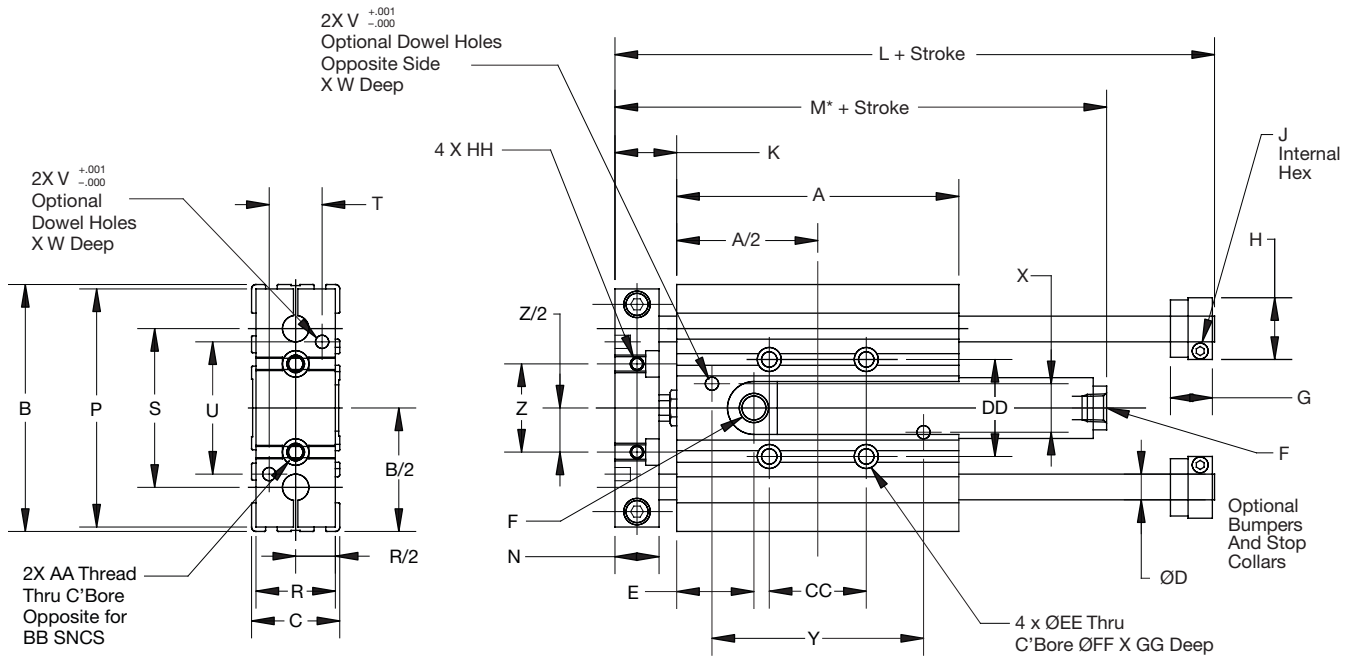
For inventory, lead time, and kit lookup, visit [www.pdnplu.com](http://www.pdnplu.com)

E133

**Parker Hannifin Corporation**  
Pneumatic Division  
Richland, Michigan  
[www.parker.com/pneumatics](http://www.parker.com/pneumatics)

Dimensional Data

XLR Series – Standard/Bumper Style Configuration



XLR Standard/ Bumper Style Dimensions

Model	A	B	C	D	E	F	G	H	J	K	L	M*	M1	N	P	R
XLR04	3.00	2.75	1.00	.250	.84	#10-32	.55	.63	3/32	.75	4.36	3.08	3.24	.50	2.63	.88
XLR06	4.00	3.50	1.25	.375	1.09	1/8 NPTF	.61	.88	7/64	.88	5.56	3.98	4.23	.63	3.38	1.13
XLR08	5.00	4.50	1.50	.500	1.38	1/8 NPTF	.67	1.13	9/64	1.00	6.75	4.60	4.85	.75	4.38	1.38
XLR12	6.50	6.00	2.00	.750	1.75	1/8 NPTF	.77	1.75	3/16	1.25	8.58	5.44	5.69	1.00	5.88	1.88

Model	S	T	U	V	X	Y	Z	AA	BB	CC	DD	EE	FF	GG	HH	
XLR04	1.750	.500	1.500	.126	.19	.438	2.000	1.000	#10-32	#6	1.000	1.000	.19	.31	.25	#8-32
XLR06	2.250	.750	1.875	.188	.22	.688	3.000	1.250	1/4-20	#10	1.375	1.375	.22	.38	.38	#10-32
XLR08	3.000	.750	2.250	.251	.25	.938	3.750	1.500	5/16-18	1/4	1.750	1.750	.28	.44	.38	1/4-20
XLR12	4.000	1.25	3.000	.313	.32	1.250	5.000	2.000	3/8-16	5/16	2.250	2.250	.34	.53	.50	5/16-18

\* Use M1 dimension when bumpers on cylinder are specified.

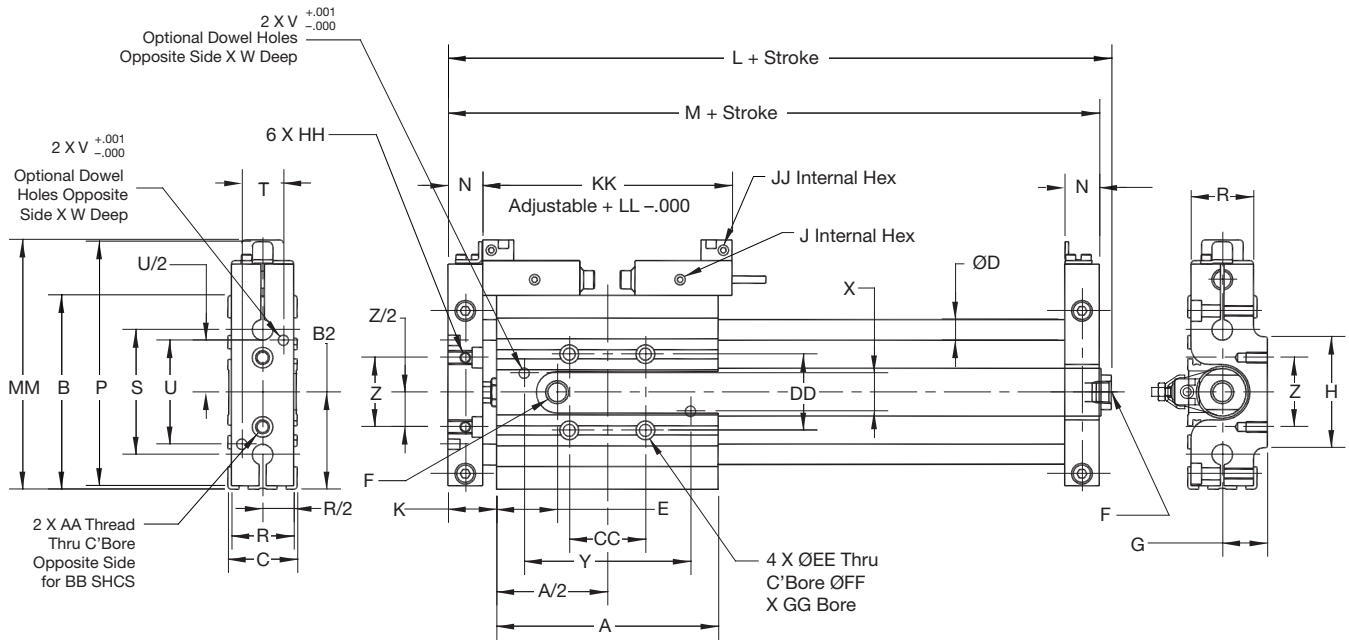
All dimensions shown in inches.



For inventory, lead times, and kit lookup, visit [www.pdnplu.com](http://www.pdnplu.com)

**U**  
 Guided  
 Cylinders  
 P5T  
 Series  
 P5L  
 Series  
 HB  
 Series  
 P5E  
 Series  
 XL  
 Series

**XLR Series – Shock Absorber/Proximity Sensor Configuration**



**XLR Shock Absorber/Proximity Sensor Dimensions**

Model	A	B	C	D	E	F	G	H	J	K	L	M
XLR04	3.00	2.75	1.00	.250	0.84	#10-32	0.63	1.50	3/32	0.75	5.34	4.50
XLR06	4.00	3.50	1.25	.375	1.09	1/8 NPTF	0.81	2.00	3/32	0.88	5.98	5.75
XLR08	5.00	4.50	1.50	.500	1.38	1/8 NPTF	1.00	2.50	1/8	1.00	7.60	7.00
XLR12	6.50	6.00	2.00	.750	1.75	1/8 NPTF	1.34	3.00	1/8	1.25	9.44	9.00

Model	N	P	R	S	T	U	V	W	X	Y	Z	AA
XLR04	0.50	3.13	0.88	1.750	0.500	1.500	0.126	0.19	0.438	2.000	1.000	#10-32
XLR06	0.63	4.38	1.13	2.250	0.750	1.875	0.188	0.22	0.688	3.000	1.250	1/4-20
XLR08	0.75	5.06	1.38	3.000	0.750	2.250	0.251	0.25	0.938	3.750	1.500	5/16-18
XLR12	1.00	6.75	1.88	4.000	1.250	3.000	0.313	0.32	1.250	5.000	2.000	3/8-16

Model	BB	CC	DD	EE	FF	GG	HH	JJ	KK	LL	MM
XLR04	#6	1.000	1.000	0.19	0.31	0.25	#8-32	3/32	3.50	1.00	3.63
XLR06	#10	1.375	1.375	0.22	0.38	0.38	#10-32	3/32	4.50	1.50	4.50
XLR08	1/4	1.750	1.750	0.28	0.44	0.38	1/4-20	3/32	5.50	1.50	5.56
XLR12	5/16	2.250	2.250	0.34	0.53	0.50	5/16-18	3/32	7.00	2.50	7.25

All dimensions shown in inches.

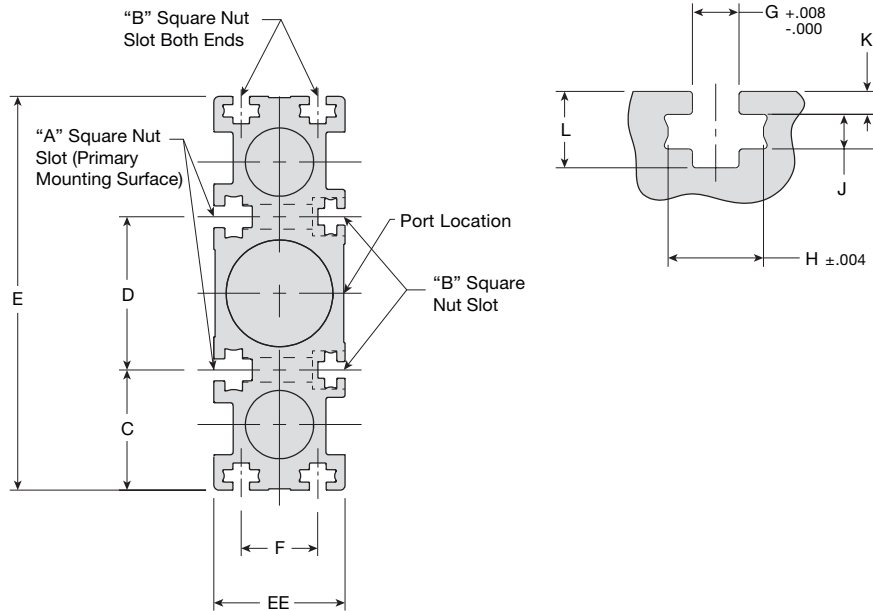


For inventory, lead time, and kit lookup, visit [www.pdnplu.com](http://www.pdnplu.com)

E135

**Parker Hannifin Corporation**  
 Pneumatic Division  
 Richland, Michigan  
[www.parker.com/pneumatics](http://www.parker.com/pneumatics)

**Square Nut "T" Slot Dimensional Information**



**Square Nut "T" Slot Dimensions**

Model	Body dimensions							Slot	Slot dimensions				
	A	B	C	D	E	EE	F		G	H	J	K	L
04	8-32	6-32	.875	1.000	2.75	1.00	.531	A	.174	.359	.141	.062	.281
								B	.138	.328	.125	.062	.234
06	10-32	8-32	1.063	1.375	3.50	1.25	.688	A	.190	.391	.141	.094	.312
								B	.164	.359	.141	.094	.312
08	1/4-20	10-32	1.375	1.750	4.50	1.50	.875	A	.250	.453	.203	.125	.438
								B	.190	.391	.141	.094	.312
12	5/16-18	1/4-20	1.875	2.250	6.00	2.00	1.250	A	.312	.578	.234	.156	.563
								B	.250	.453	.202	.125	.438

**Square Nut Kits**

Each slide is equipped with (4) square nuts for the "A" slot and (4) for the "B" slot. Additional square nuts can be ordered. Each kit contains 8 square nuts (4 primary, 4 secondary).

Model	Kit number
04	NK04
06	NK06
08	NK08
12	NK12

All dimensions shown in inches.



For inventory, lead times, and kit lookup, visit [www.pdnplu.com](http://www.pdnplu.com)

E136

**Parker Hannifin Corporation**  
Pneumatic Division  
Richland, Michigan  
[www.parker.com/pneumatics](http://www.parker.com/pneumatics)

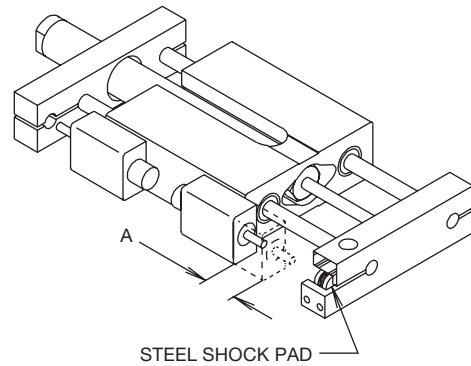
Options

Shock/Stroke Adjuster (A, A1, A2)

Available on XLR only

Shock absorbers dissipate energy and reduce noise, allowing increased operating speeds. Shocks are fixed orifice, self-compensating type and will provide constant deceleration despite changing energy conditions. The shock housing is designed as a stop. By moving the shock housing, the stroke is adjusted. Maximum allowable stroke adjustment is shown. Shocks are available at both ends, extend, or retract.

**NOTE:** Do not allow the shock to protrude through the adjustable stop housing as damage may occur if the shock comes into contact with the tool plate. Additionally, damage may occur if the shock piston rod is twisted or turned.



Shock Ready (A3, A4, A5)

Available on XLR only

Shock absorber bracket(s) and tooling plate(s) are provided. Shock may be field added.

Maximum Allowable Stroke Adjustment

Model	A
04	0.50
06	0.75
08	0.75
12	1.25

Bumpers/Adjustable Stop Collars

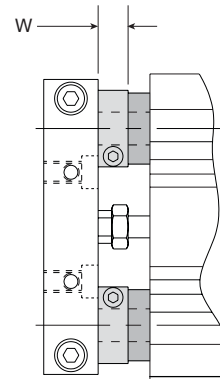
(B, B1, B2, B3, B4)

Bumpers absorb shock, reduce noise, and permit faster cycle times thereby increasing production rates. They can be placed on the extend, retract or both positions.

When bumpers are specified, adjustable stop collars are supplied on the extend stroke as standard. An extend stop collar provides travel adjustment. A stop collar can also be specified for the retract stroke. This stop collar is optional and is only provided if requested. The retract stop collar option (B3) and the stop collar both ends option (B4) reduce the stroke of the slide by the dimension shown.

EXAMPLE:

Four inches of stroke are desired with an adjustable stop collar on the retract position. Utilizing the table, a "W" dimension for an 04 size unit would be .28". A 4" stroke unit would have a net stroke of 3.72". If the full 4" of stroke is required, a 5" stroke unit must be ordered. The stops can then be adjusted to provide the desired stroke of 4".



Model	W
04	.281
06	.344
08	.406
12	.500



Guided Cylinders

P5T Series

P5L Series

HB Series

P5E Series

XL Series

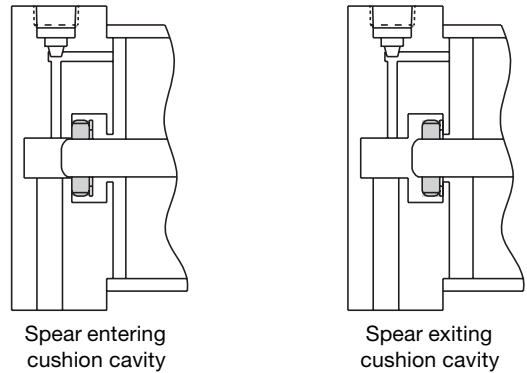


For inventory, lead time, and kit lookup, visit [www.pdnplu.com](http://www.pdnplu.com)

**Options**

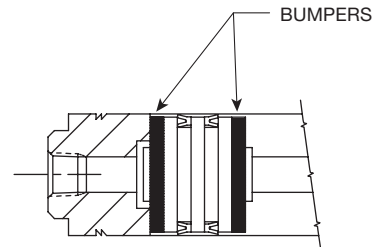
**Cushions on Cylinder (C)**

Optional cylinder cushions are available at both ends. The check seal cushions float radially and longitudinally to compensate for problems with misalignment. Flow paths molded on the circumference of the seal allow exceptionally rapid return stroke without the use of ball checks. A captive cushion screw provides safe cushion adjustment while the cylinder is pressurized. The brass adjustment screw provides maximum corrosion resistance. The cushion adjustment screw is hidden by the XL housing. The cushion adjustment screw is factory set at full cushion less 1/2 of a turn



**Bumpers on Cylinder (D)**

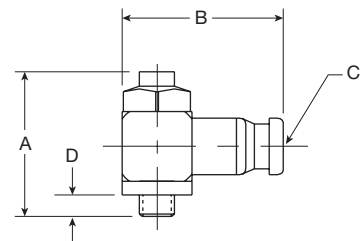
Available on both ends only, bumpers can be specified on the cylinder to reduce noise and increase operating speeds. Bumpers add length to the cylinder. See Dimensional Data for "M1" length.




**Flow Controls (F, G)**

Right angle flow control valves allow precise adjustment of cylinder speed by metering exhaust air flow. Prestolok push-in or NPT ports provide 360° orientation capability.

Model	A	B		C		D	Thickness
		Prestolok	NPT	Prestolok	NPT		
04	1.63	1.38	1.18	5/32	N/A	.16	.67
06	1.63	1.38	1.18	5/32	1/8	.44	.67
08	1.63	1.38	1.18	1/4	1/8	.44	.67
12	1.63	1.38	1.18	1/4	1/8	.44	.67




  
 Guided Cylinders
   
  
 P5T Series
   
  
 P5L Series
   
  
 HB Series
   
  
 P5E Series
   
  
 XL Series



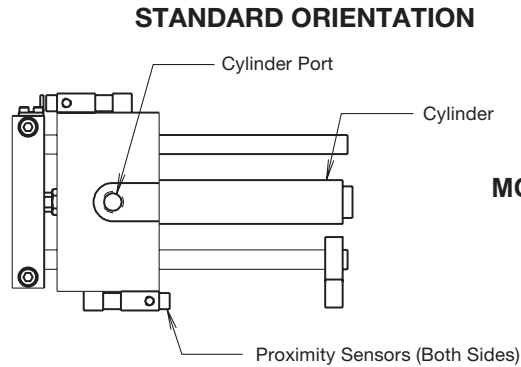
For inventory, lead times, and kit lookup, visit [www.pdnplu.com](http://www.pdnplu.com)

**XLT Series Left Hand Assembly (L)**

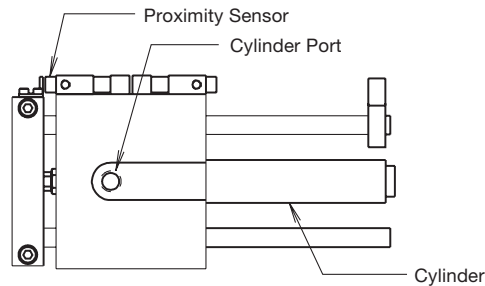
When proximity sensors are specified, 04, 06, and 08 models are shipped with the cylinder mounted on the right hand side of the slide when viewing the cylinder port. The proximity sensors are oriented in the upper left and lower right position. On the 12 model, the proximity sensors are mounted in the upper right and left orientation.

The slide can be ordered with the cylinder on the opposite side by specifying an "L" in the model number. See figure below.

Units without proximity sensors are symmetrical and are not affected.

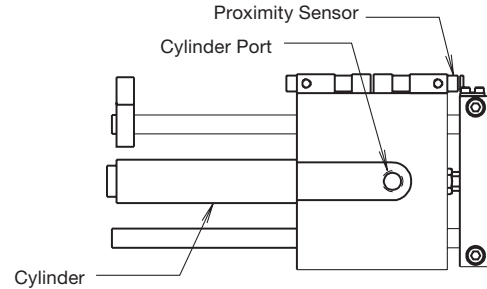
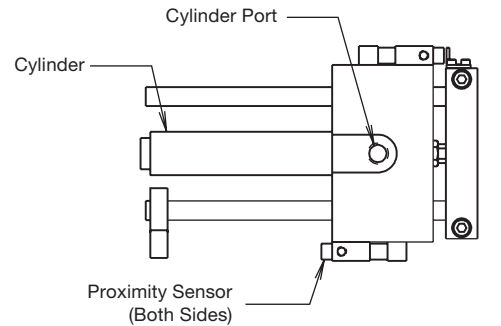


**MODELS 04, 06, 08**



**MODEL 12**

**LEFT HAND ORIENTATION**



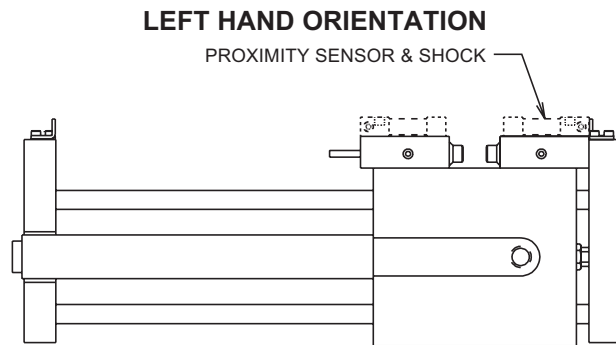
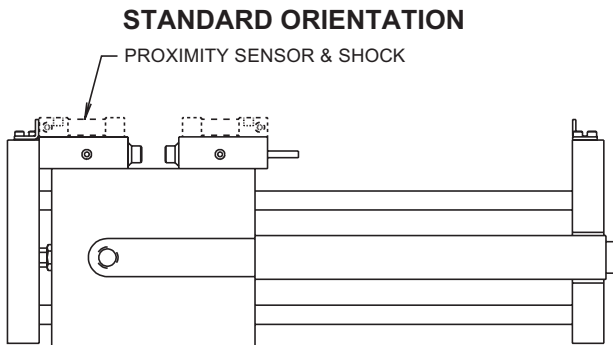
**XLR Series Left Hand Assembly (L)**

When proximity sensors or shock absorbers are specified, 04 and 06 models are shipped with the cylinder mounted on the right hand side of the slide when viewing the cylinder port.

The proximity sensors are oriented in the upper left and lower right position. On the 08 and 12 models, the proximity sensors are mounted in the upper right and left orientation.

The slide can be ordered with the cylinder on the opposite side by specifying an "L" in the model number. See figure below.

Units without proximity sensors and/or shock absorbers are symmetrical and are not affected.



Guided Cylinders

P5T Series

P5L Series

HB Series

P5E Series

**XL Series**



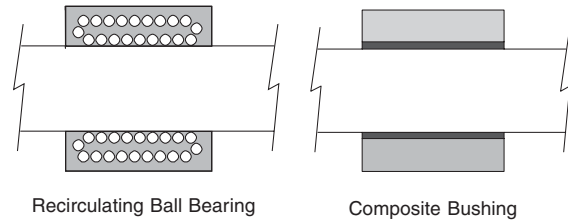
For inventory, lead time, and kit lookup, visit [www.pdnplu.com](http://www.pdnplu.com)

**Options**

**Composite Bushings (T)**

Selection should be based on the following criteria:

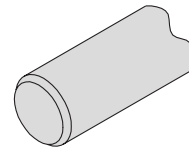
Application Requirement	Ball Bearing	Composite
Precision	Excellent	Good
Friction	Low	Higher
Friction Coefficient	Constant	Variable
Precision over Life of Bearing	Constant	Variable
Static Load Capacity	Good	Excellent
Dynamic Load Capacity	Good	Good with lower efficiency
Lubrication	Required	Not required
Vibration Resistance	Fair	Excellent
Contamination Resistance	Fair	Excellent
Washdown Compatibility	Poor	Excellent



For bushing load capacities, reference the Engineering Data pages of this section.

**Stainless Steel Shafts (K)**

Case-hardened, high carbon alloy steel shafting is utilized for standard slides. Stainless steel shafting can be specified for corrosive applications.



**Fluorocarbon Piston Seals (V)**


Standard abrasion resistant nitrile seals should be used for general purpose applications with temperatures of 0 to 165°F. Fluorocarbon seals are recommended for high temperature applications up to 250°F.

Option	Temperature Range* (°F)
Bumpers	0 to 200
Piston Magnets	0 to 165
Switches	14 to 140

\*Consult factory for higher temperature operation.

**Dowel Pin Holes (E)**

See Basic Dimensions for location


 Guided Cylinders  
 P5T Series  
 P5L Series  
 HB Series  
 P5E Series  
 XL Series



For inventory, lead times, and kit lookup, visit [www.pdnplu.com](http://www.pdnplu.com)

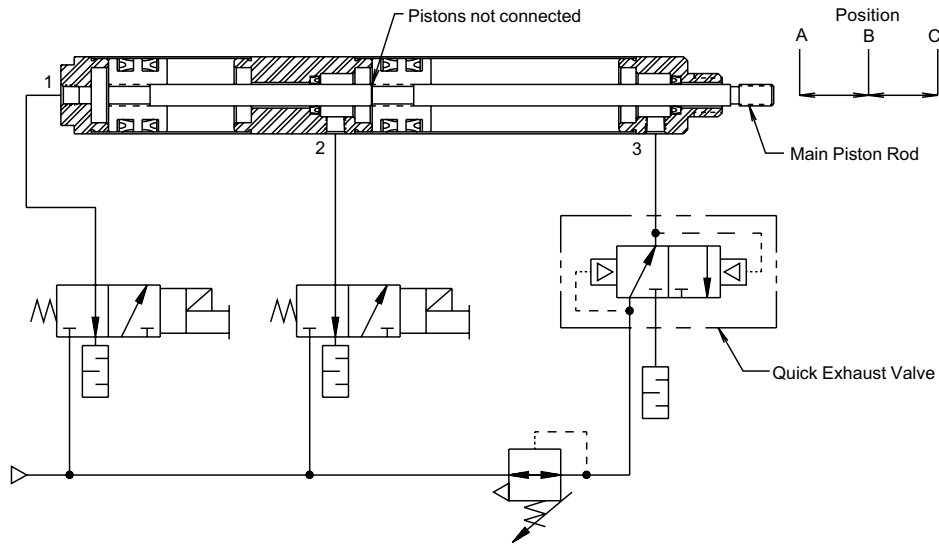


Options

Three Position Unit

The three position unit utilizes a duplex air cylinder to provide the center position. This option can be specified with all other options. However, bumpers and body mounted inductive proximity sensors operate on the fully extended and retracted positions only. Cylinder mounted reed and Hall Effects switches can be used to detect the center position of the slide.

Sample Circuit



Operation:

Position A (fully retracted) is obtained by applying pressure to Port 3 with Ports 2 and 1 vented to atmosphere. Position B (mid-position) is obtained by applying pressure to Port 1 while maintaining a lower pressure to Port 3. The pressure at Port 3 prevents the main piston rod from over-travel.

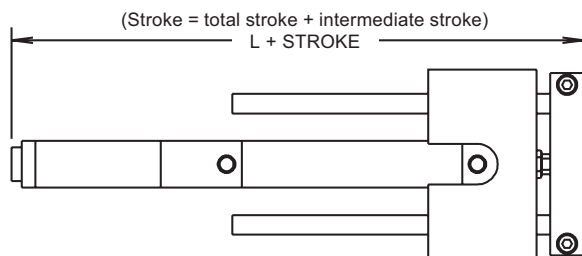
A quick exhaust valve can be used to maintain pressure while allowing full exhaust capability. Position C (fully extended) is obtained by applying pressure to Port 2.

Maximum Allowable Stroke Adjustment

Model	Stroke
04	3
06	6
08	9
12	12

Dimensional Data:

Three position units utilize a longer cylinder. All other dimensions remain the same.



Model	L
04	5.50
06	6.71
08	7.51
12	8.71

## Options

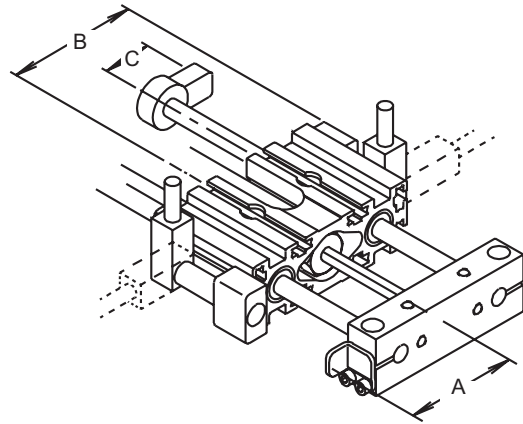
### Proximity Sensors

Proximity sensors can sense the extend and retract positions of the slide. The proximity sensor is attached to the side of the slide, utilizing the square nut "T" slots. The sensor is installed at the factory and does not require adjustment. Should adjustment be necessary, care should be taken to ensure that the sensor does not come into contact with the tool plate. At the end of stroke, the distance from the tool plate to the sensor should be approximately .016 inches.

#### Electrical Specifications

Voltage:	10-30 VDC (3 wire) PNP or NPN
No load current:	5.5-9.5 mA
Continuous current:	150 mA
Switching speed:	8 ms
Switch frequency:	5000 Hz
Switching distance:	Aluminum = 0.016 in (0.4mm) Brass = 0.028 in (0.7mm) Steel = 0.039 in (1.0mm)
Overload protection:	Triggered at 170 mA
Reverse polarity protection:	Incorporated
Temperature range:	-13 to 158°F (-25 to 70°C)
Enclosure:	Meets NEMA 1,3,4,6,13 and IEC IP67, fully encapsulated

## Guided Pneumatic Cylinders XLT and XLR Series



Model	A	B	C
XLT04	1.69	1.75	0.81
XLT06	2.06	1.88	0.94
XLT08	2.56	2.66	1.06
XLT12	3.31	N/A*	1.31

\* On Model 04, 06 and 08, the extend proximity sensor mounts opposite the retract proximity sensor as shown. On Model 12, the proximity sensors mount on the same side.

Guided Cylinders

P5T Series

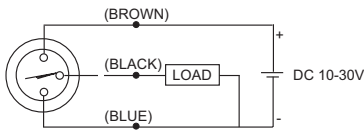
P5L Series

HB Series

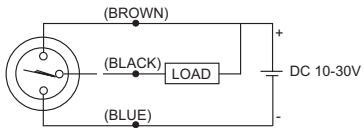
P5E Series

XL Series

#### PNP WIRING CONNECTION

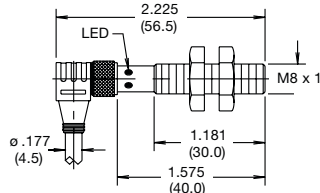


#### NPN WIRING CONNECTION



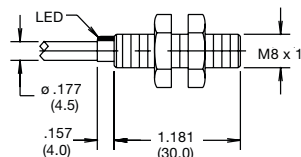
#### Plug-in sensor (P1, N1)

A threaded right angle cordset is included as standard. The cordset contains two LEDs: 1- power, 2 - target indication. Cordset length is 20 ft. (6m).

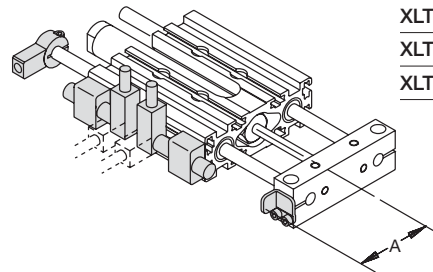


#### Potted-in sensor (P, N)

Lead type sensor with 20 ft. (6m) cord length

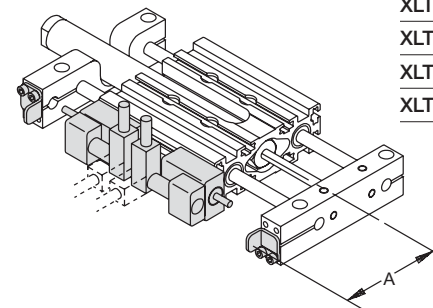


#### XLR Proximity Sensor without Shock Option



Model	"A"	
	8mm	12mm
XLT04	1.69	N/A
XLT06	2.06	N/A
XLT08	2.56	2.72
XLT12	3.31	3.47

#### XLR Proximity Switch with Shock Option



Model	"A"	
	8mm	12mm
XLT04	2.13	N/A
XLT06	2.56	N/A
XLT08	3.09	3.25
XLT12	3.94	3.47



For inventory, lead times, and kit lookup, visit [www.pdnplu.com](http://www.pdnplu.com)

**Switch Characteristics**

**Proximity Sensors**

- End of stroke sensing
- Solid state electronics
- LED indicator on plug-in style switch
- 10-30 VDC
- PNP and NPN available
- Senses metal tool plate
- Highest cost
- Long life

**Hall Effect Switches**

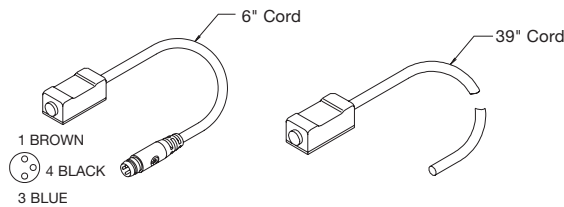
- Fully adjustable travel
- Solid state electronics
- LED indicator
- 6-30 VDC
- PNP and NPN available
- Senses magnet on cylinder piston
- Medium cost
- Long life

**Reed Switches**

- Fully adjustable travel
- Mechanical reed
- LED indicator
- 6-30 VDC or 85-150 VAC
- Senses magnet on cylinder piston
- Lowest cost
- Medium life

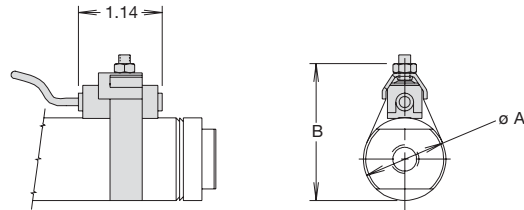
**Switches (order separately)**

Description	Part number
PNP Hall Effect w/6" male plug-in connector	<b>146715000C</b>
NPN Hall Effect w/6" male plug-in connector	<b>146714000C</b>
PNP Hall Effect w/39" potted-in leads	<b>1467150000</b>
NPN Hall Effect w/39" potted-in leads	<b>1467140000</b>
Reed switch w/6" male plug-in connector	<b>145903000C</b>
Reed switch w/39" potted-in leads	<b>1459030000</b>



**Switch Clamps (order separately)**

Model	ØA	B	Part number
04	0.62	1.35	<b>L074730056</b>
06	0.86	1.60	<b>L074730075</b>
08	1.12	1.86	<b>L074730106</b>
12	1.56	2.30	<b>L074730150</b>



**Cordset With Female Quick Connect (order separately)**

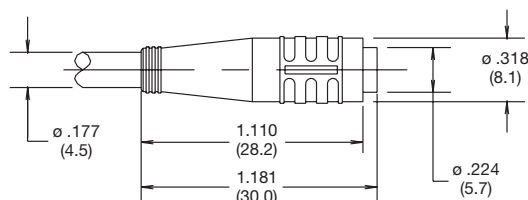
A female connector is available for all switches with the male quick connect option. The male plug will accept a snap-on or threaded connector. Parker's cordset part numbers and other manufacturer's part numbers are listed below:

Manufacturer	Threaded Connector	Snap-On Connector
Parker	<b>B8786</b>	<b>B8785</b>
Brad Harrison	<b>45310-102</b>	<b>45300-102</b>
Lumberg	<b>RKMV3-G1/5m</b>	<b>RKM3-G1/5m</b>
Hirschmann	—	<b>ELKA-K308PUR014</b>
Turck	<b>PKG 3M-6/S90</b>	<b>PKG 3-6/S90</b>

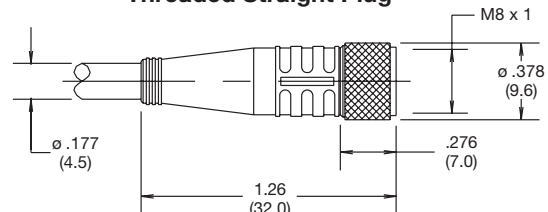
**Cordset Specifications:**

Connector:	Oil resistant polyurethane body material, PA 6 (Nylon) contact carrier, spacings to VDE 0110 Group C, (30 VAC/36 VDC)
Contacts:	Gold plated beryllium copper, machined from solid stock
Coupling method:	Snap-Lock or chrome plated brass nut
Cord construction:	Oil resistant black PUR jacket, non-wicking, non-hygroscopic, 300V. Cable end is stripped and tinned.
Conductors:	Extra high flex stranding, PVC insulation
Temperature:	-40 to 194°F (-40 to 90°C)
Protection:	NEMA 1,3,4,6P and IEC IP67
Cable length:	20 ft. (6m.)

**Snap-on Straight Plug**



**Threaded Straight Plug**



For inventory, lead time, and kit lookup, visit [www.pdnplu.com](http://www.pdnplu.com)

**Options**

**Switch Specifications**

**Hall Effect Switches**

Type:	Solid State (PNP or NPN)
Switching Logic:	Normally Open
Supply Voltage Range:	6 - 30 VDC
Current Output Range:	Up to 100 mA at 5 VDC, Up to 200 mA at 12 VDC and 24 VDC
Current Consumption:	7 mA at 5 VDC, 15 mA at 12 VDC, and 30 mA at 24 VDC
Switching Frequency:	1000 Hz Maximum
Residual Voltage:	1.5V Maximum
Leakage Current:	10uA Maximum
Breakdown Voltage:	1.8kVACrms for 1 sec., lead to case
Min. Current for LED:	1 mA
Operating Temperature:	14 to 140°F (-10 to 60°C)
Enclosure Protection:	Meets IEC IP67, fully encapsulated
Lead Wire:	3 conductor, 24 gauge
Lead Wire Length:	39 in (1m)
Vibration Resistance:	10-55 Hz, 1.5mm double amplitude

**Reed Switches**

Switching Logic:	Normally open, SPST
Voltage Rating:	85-125 VAC or 6-30 VDC*
Power Rating:	10 Watts AC or DC/resistive load 5 Watts AC or DC/inductive load
Switching Current Range:	30-200 mA/resistive load (PC, sequencer) 30-100 mA/inductive load (relay)
Switching Frequency:	300 Hz maximum
Breakdown Voltage:	1.8kVACrms for 1 sec., lead to case
Min. Current for LED:	18 mA
Operating Temperature:	14 to 140°F (-10 to 60°C)
Enclosure Protection:	Meets IEC IP67, fully encapsulated
Lead Wire:	2 conductor, 22 Gauge
Lead Wire Length:	39 in (1m)
Vibration Resistance:	10-55 Hz, 1.5mm double amplitude

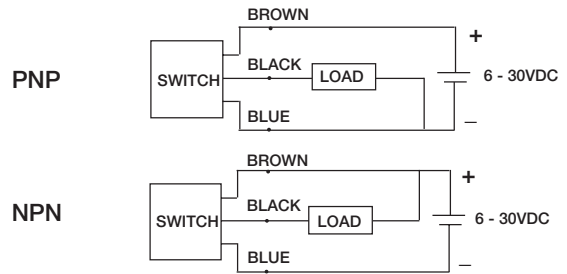
\* Polarity is restricted for DC operation

(+) to Brown

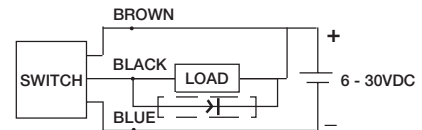
(-) to Blue

If these connections are reversed, the contacts will close but the LED will not light.

**WIRING CONNECTION**



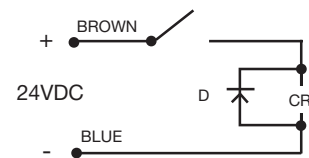
**PROTECTION CIRCUIT\***



\* When connecting an inductive load (relay, solenoid valve, etc.), a protection circuit is recommended. Use a 100V, 1A diode. (NPN connection shown.)

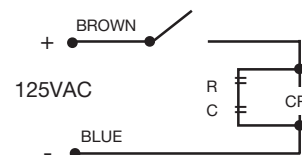
**PROTECTION CIRCUIT (INDUCTIVE LOADS)**

(Required for proper operation 24VDC)  
 Select a diode with a breakdown voltage and current rating according to the load. Place a diode in parallel to the load with the polarity as indicated:



CR: Relay coil (under 0.5W coil rating)

(Recommended for longer switch life 125VAC)  
 Select a resistor and capacitor according to the load. Place a resistor and capacitor in parallel to the load:



CR: Relay coil (under 2W coil rating)  
 R: Resistor under 1 K ohm  
 C: Capacitor 0.1 µF

Guided Cylinders

P5T Series

P5L Series

HB Series

P5E Series

XL Series



For inventory, lead times, and kit lookup, visit [www.pdnplu.com](http://www.pdnplu.com)

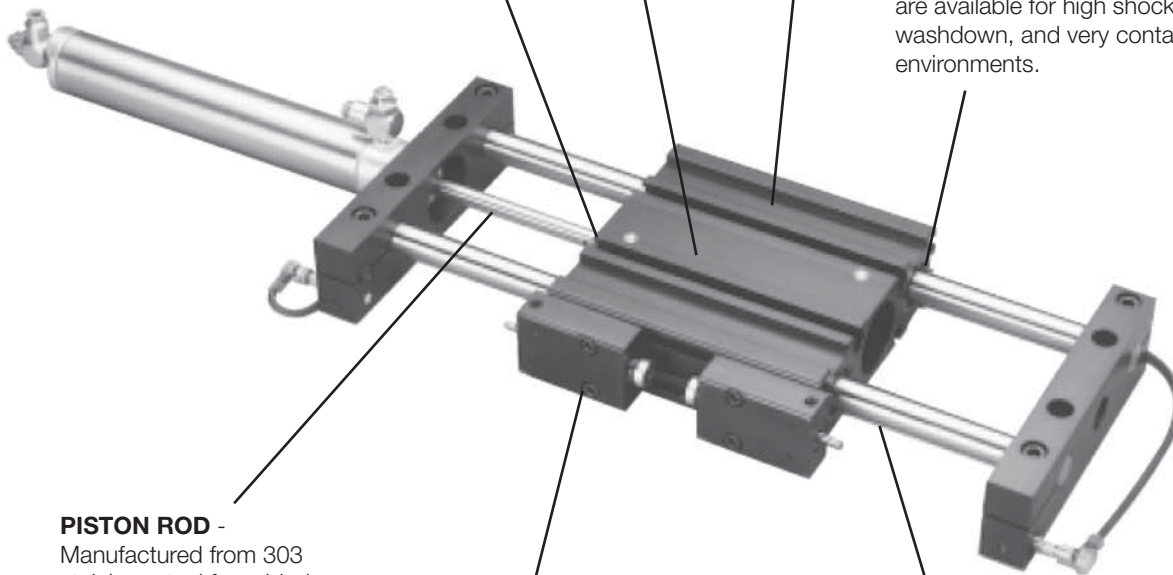
**XLB Series**

**PATENTED CYLINDER ALIGNMENT COUPLER\*** - Allows piston rod to self-center thus extending cylinder life especially when the support shafts deflect under load.

**LIGHTWEIGHT BODY** - A unique extruded aluminum profile reduces weight which allows for less inertia in applications requiring the body's movement.

**SQUARE NUT "T" SLOTS** - Are extruded into the main housing for mounting flexibility and quick setup. For added flexibility, through holes are standard and dowel pin holes are optional.

**BEARINGS** - Sealed recirculating ball bearings provide precise alignment with very low friction and wear. Optional composite bushings are available for high shock, washdown, and very contaminated environments.



**PISTON ROD** - Manufactured from 303 stainless steel for added protection and corrosion resistance.

**SHOCK/STROKE ADJUSTERS** - Shock absorbers integrated with an adjustable positive stop provides smooth deceleration and stroke adjustment. One adjustment moves both components in unison – eliminating multiple iterations during setup. Shocks can be added in the field.

**SUPPORT SHAFTS** - Case hardened to Rc 60-65, support shafts are machined from high carbon alloy steel. This extreme surface hardness protects the shaft's round ways from nicks and scratches - enhancing component life and reducing maintenance.

\*U.S. Patent #5,413,031

<b>M</b>
Guided Cylinders
P5T Series
P5L Series
HB Series
P5E Series
XL Series



For inventory, lead time, and kit lookup, visit [www.pdnplu.com](http://www.pdnplu.com)

**Features**

**XLB Series Base Slides**

Designed for lighter loads, the XLB Series base slide provides precise, torque resistant linear motion in a very light weight, compact package. Built into the main body, or saddle, an alignment coupler allows the piston rod to self-center. This extends cylinder life especially when the support shafts deflect under load.

The main body is manufactured from anodized extruded aluminum incorporating "T" slots for mounting flexibility. "T" slots support optional stroke adjusters and shock absorbers. One adjustment moves both components in unison – eliminating multiple iterations during setup.

Supported by the main body are four pre-lubricated recirculating ball bearings and two precision ground

support shafts. Optional composite bushings may be specified. Outboard wiper seals protect the bearings from contamination and retain lubrication. This ensures long life with reduced maintenance. A pre-lubricated stainless steel air cylinder with a stainless steel piston rod provides thrust while the support shafts and bearings provide positive load support for millions of non-lube, trouble-free cycles.

Available options include reed, Hall Effect and inductive proximity sensors, prox ready, self-compensating hydraulic shock absorbers, shock ready, bumpers, adjustable stop collars, flow controls, fluorocarbon seals and 3-position cylinders.

**Ordering information**

<b>XLB</b>	<b>08</b>	-	<b>06</b>	<b>B</b>	<b>P</b>	<b>L</b>	-	<b>FV</b>	-	<b>B</b>																																															
<table border="1" style="width: 100%; border-collapse: collapse;"> <tr><th colspan="2">Series</th></tr> <tr><td><b>XLB</b></td><td>XL series base slide</td></tr> </table>		Series		<b>XLB</b>	XL series base slide					<table border="1" style="width: 100%; border-collapse: collapse;"> <tr><th colspan="2">Slide orientation</th></tr> <tr><td>Omit</td><td>Standard</td></tr> <tr><td><b>L</b></td><td>Left hand assembly</td></tr> </table>		Slide orientation		Omit	Standard	<b>L</b>	Left hand assembly			<table border="1" style="width: 100%; border-collapse: collapse;"> <tr><th colspan="2">Special options / modifications</th></tr> <tr><td>Omit</td><td>Standard unit</td></tr> <tr><td colspan="2">(Two digit code assigned by factory when any "X" appears in the model number or when special options or features are required.)</td></tr> </table>		Special options / modifications		Omit	Standard unit	(Two digit code assigned by factory when any "X" appears in the model number or when special options or features are required.)																															
Series																																																									
<b>XLB</b>	XL series base slide																																																								
Slide orientation																																																									
Omit	Standard																																																								
<b>L</b>	Left hand assembly																																																								
Special options / modifications																																																									
Omit	Standard unit																																																								
(Two digit code assigned by factory when any "X" appears in the model number or when special options or features are required.)																																																									
		<table border="1" style="width: 100%; border-collapse: collapse;"> <tr><th colspan="2">Model</th></tr> <tr><td><b>04</b></td><td>1/4" dia. support shaft, 9/16" dia. bore cylinder</td></tr> <tr><td><b>06</b></td><td>3/8" dia. support shaft, 3/4" dia. bore cylinder</td></tr> <tr><td><b>08</b></td><td>1/2" dia. support shaft, 1-1/16" dia. bore cylinder</td></tr> <tr><td><b>12</b></td><td>3/4" dia. support shaft, 1-1/2" dia. bore cylinder</td></tr> </table>		Model		<b>04</b>	1/4" dia. support shaft, 9/16" dia. bore cylinder	<b>06</b>	3/8" dia. support shaft, 3/4" dia. bore cylinder	<b>08</b>	1/2" dia. support shaft, 1-1/16" dia. bore cylinder	<b>12</b>	3/4" dia. support shaft, 1-1/2" dia. bore cylinder							<table border="1" style="width: 100%; border-collapse: collapse;"> <tr><th colspan="2">Design series</th></tr> <tr><td><b>B</b></td><td>Current</td></tr> </table>		Design series		<b>B</b>	Current																																
Model																																																									
<b>04</b>	1/4" dia. support shaft, 9/16" dia. bore cylinder																																																								
<b>06</b>	3/8" dia. support shaft, 3/4" dia. bore cylinder																																																								
<b>08</b>	1/2" dia. support shaft, 1-1/16" dia. bore cylinder																																																								
<b>12</b>	3/4" dia. support shaft, 1-1/2" dia. bore cylinder																																																								
Design series																																																									
<b>B</b>	Current																																																								
		<table border="1" style="width: 100%; border-collapse: collapse;"> <tr><th colspan="2">Stroke length (inch)</th></tr> <tr><td colspan="2">Order in 1" increments. See quick reference table on next page for maximum stroke lengths for each model. For three position units, specify intermediate and total stroke separated by a "/", ie 02/06.</td></tr> </table>		Stroke length (inch)		Order in 1" increments. See quick reference table on next page for maximum stroke lengths for each model. For three position units, specify intermediate and total stroke separated by a "/", ie 02/06.								<table border="1" style="width: 100%; border-collapse: collapse;"> <tr><th colspan="2">Other options (More than one selection is possible)</th></tr> <tr><td>Omit</td><td>None</td></tr> <tr><td><b>D</b></td><td>Bumpers on cylinder only</td></tr> <tr><td><b>E</b></td><td>Dowel pin holes</td></tr> <tr><td><b>F</b></td><td>Flow controls (Prestolok)</td></tr> <tr><td><b>G</b></td><td>Flow controls (NPT)<sup>1</sup></td></tr> <tr><td><b>K</b></td><td>Stainless steel support shafts</td></tr> <tr><td><b>T</b></td><td>Composite bushings</td></tr> <tr><td><b>V</b></td><td>Fluorocarbon piston seals</td></tr> <tr><td><b>X</b></td><td>Special (detail in clear text)</td></tr> </table>		Other options (More than one selection is possible)		Omit	None	<b>D</b>	Bumpers on cylinder only	<b>E</b>	Dowel pin holes	<b>F</b>	Flow controls (Prestolok)	<b>G</b>	Flow controls (NPT) <sup>1</sup>	<b>K</b>	Stainless steel support shafts	<b>T</b>	Composite bushings	<b>V</b>	Fluorocarbon piston seals	<b>X</b>	Special (detail in clear text)																						
Stroke length (inch)																																																									
Order in 1" increments. See quick reference table on next page for maximum stroke lengths for each model. For three position units, specify intermediate and total stroke separated by a "/", ie 02/06.																																																									
Other options (More than one selection is possible)																																																									
Omit	None																																																								
<b>D</b>	Bumpers on cylinder only																																																								
<b>E</b>	Dowel pin holes																																																								
<b>F</b>	Flow controls (Prestolok)																																																								
<b>G</b>	Flow controls (NPT) <sup>1</sup>																																																								
<b>K</b>	Stainless steel support shafts																																																								
<b>T</b>	Composite bushings																																																								
<b>V</b>	Fluorocarbon piston seals																																																								
<b>X</b>	Special (detail in clear text)																																																								
		<table border="1" style="width: 100%; border-collapse: collapse;"> <tr><th colspan="2">Slide configuration options</th></tr> <tr><td>Omit</td><td>None</td></tr> <tr><td><b>A</b></td><td>Shock / stroke adjust, both ends</td></tr> <tr><td><b>A1</b></td><td>Shock / stroke adjust, extend only</td></tr> <tr><td><b>A2</b></td><td>Shock / stroke adjust, retract only</td></tr> <tr><td><b>A3</b></td><td>Shock ready, both ends</td></tr> <tr><td><b>A4</b></td><td>Shock ready, extend only</td></tr> <tr><td><b>A5</b></td><td>Shock ready, retract only</td></tr> <tr><td><b>B</b></td><td>Bumpers, both ends<sup>2</sup></td></tr> <tr><td><b>B1</b></td><td>Bumpers, extend only<sup>2</sup></td></tr> <tr><td><b>B2</b></td><td>Bumpers, retract only<sup>2</sup></td></tr> <tr><td><b>B3</b></td><td>Bumpers, adjustable stop collar, retract only<sup>2</sup></td></tr> <tr><td><b>B4</b></td><td>Bumpers, adjustable stop collar, both ends<sup>2</sup></td></tr> <tr><td><b>B5</b></td><td>Bumpers, adjustable stop collar, extend only<sup>2</sup></td></tr> <tr><td><b>C</b></td><td>Cushions on cylinder, both ends</td></tr> <tr><td><b>X</b></td><td>Special (detail in clear text)</td></tr> </table>		Slide configuration options		Omit	None	<b>A</b>	Shock / stroke adjust, both ends	<b>A1</b>	Shock / stroke adjust, extend only	<b>A2</b>	Shock / stroke adjust, retract only	<b>A3</b>	Shock ready, both ends	<b>A4</b>	Shock ready, extend only	<b>A5</b>	Shock ready, retract only	<b>B</b>	Bumpers, both ends <sup>2</sup>	<b>B1</b>	Bumpers, extend only <sup>2</sup>	<b>B2</b>	Bumpers, retract only <sup>2</sup>	<b>B3</b>	Bumpers, adjustable stop collar, retract only <sup>2</sup>	<b>B4</b>	Bumpers, adjustable stop collar, both ends <sup>2</sup>	<b>B5</b>	Bumpers, adjustable stop collar, extend only <sup>2</sup>	<b>C</b>	Cushions on cylinder, both ends	<b>X</b>	Special (detail in clear text)			<table border="1" style="width: 100%; border-collapse: collapse;"> <tr><th colspan="2">Slide proximity sensor options</th></tr> <tr><td>Omit</td><td>None</td></tr> <tr><td><b>P</b></td><td>PNP lead type</td></tr> <tr><td><b>N</b></td><td>NPN lead type</td></tr> <tr><td><b>P1</b></td><td>PNP, plug in leads</td></tr> <tr><td><b>N1</b></td><td>NPN, plug in leads</td></tr> <tr><td><b>J</b></td><td>Prox ready, 8mm (no sensors supplied)</td></tr> </table>		Slide proximity sensor options		Omit	None	<b>P</b>	PNP lead type	<b>N</b>	NPN lead type	<b>P1</b>	PNP, plug in leads	<b>N1</b>	NPN, plug in leads	<b>J</b>	Prox ready, 8mm (no sensors supplied)			<p><b>Note:</b> Inductive proximity sensors are included with the P, N, P1 &amp; N1 options. Order Reed and Hall Effect switches separately. See chart on next page.                  Piston magnet is provided as standard.</p>	
Slide configuration options																																																									
Omit	None																																																								
<b>A</b>	Shock / stroke adjust, both ends																																																								
<b>A1</b>	Shock / stroke adjust, extend only																																																								
<b>A2</b>	Shock / stroke adjust, retract only																																																								
<b>A3</b>	Shock ready, both ends																																																								
<b>A4</b>	Shock ready, extend only																																																								
<b>A5</b>	Shock ready, retract only																																																								
<b>B</b>	Bumpers, both ends <sup>2</sup>																																																								
<b>B1</b>	Bumpers, extend only <sup>2</sup>																																																								
<b>B2</b>	Bumpers, retract only <sup>2</sup>																																																								
<b>B3</b>	Bumpers, adjustable stop collar, retract only <sup>2</sup>																																																								
<b>B4</b>	Bumpers, adjustable stop collar, both ends <sup>2</sup>																																																								
<b>B5</b>	Bumpers, adjustable stop collar, extend only <sup>2</sup>																																																								
<b>C</b>	Cushions on cylinder, both ends																																																								
<b>X</b>	Special (detail in clear text)																																																								
Slide proximity sensor options																																																									
Omit	None																																																								
<b>P</b>	PNP lead type																																																								
<b>N</b>	NPN lead type																																																								
<b>P1</b>	PNP, plug in leads																																																								
<b>N1</b>	NPN, plug in leads																																																								
<b>J</b>	Prox ready, 8mm (no sensors supplied)																																																								
<p><b>NOTES:</b></p> <p><sup>1</sup> Not available on Model 04.</p> <p><sup>2</sup> Bumpers on cylinder are included with all "B" options at no extra charge.</p>																																																									

<b>XLB</b>	Guided Cylinders
	PST Series
	P5L Series
	HB Series
	P5E Series
	XL Series



For inventory, lead times, and kit lookup, visit [www.pdnplu.com](http://www.pdnplu.com)

**Specifications**

- Maximum operating pressure: 100 psi
- Operating characteristics:  
double acting standard (single acting available)
- Four support shaft sizes: 1/4", 3/8", 1/2" and 3/4"
- Stroke tolerance: +.060, -.000
- Mounting: unrestricted
- Operating temperature range (cylinder):  
Standard seals 0 to 165°F  
Fluorocarbon seals\* 0 to 250°F
- Filtration requirement: 40 micron filtered, dry air

\* See fluorocarbon seal option for high temperature applications.

**Quick Reference Data**

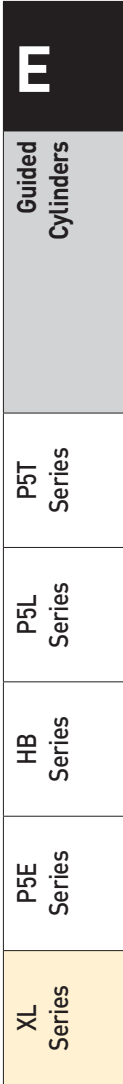
Series	Model	Support rod diameter (in)	Cylinder bore size (in)	Maximum stroke (in)	Force output on extension at 80 psi (lb)	Force output on retraction at 80 psi (lb)	Unit weight (lb)	
							Base	Per inch
XLB	04	1/4	9/16	12	20	18	1.05	0.052
	06	3/8	3/4	12	35	31	2.15	0.098
	08	1/2	1-1/16	18	70	64	3.95	0.163
	12	3/4	1-1/2	24	140	128	9.30	0.335

**Switches**

Description	Part number
PNP Hall Effect w/6" male plug-in connector	<b>146715000C</b>
NPN Hall Effect w/6" male plug-in connector	<b>146714000C</b>
PNP Hall Effect w/39" potted-in leads	<b>1467150000</b>
NPN Hall Effect w/39" potted-in leads	<b>1467140000</b>
Reed switch w/6" male plug-in connector	<b>145903000C</b>
Reed switch w/39" potted-in leads	<b>1459030000</b>

**Clamps**

Model	Part number
04	<b>L074730056</b>
06	<b>L074730075</b>
08	<b>L074730106</b>
12	<b>L074730150</b>



For inventory, lead time, and kit lookup, visit [www.pdnplu.com](http://www.pdnplu.com)

E147

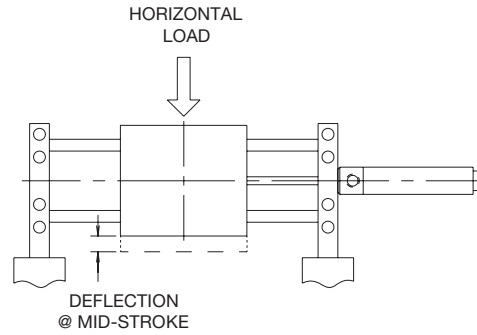
**Parker Hannifin Corporation**  
Pneumatic Division  
Richland, Michigan  
[www.parker.com/pneumatics](http://www.parker.com/pneumatics)

**Horizontal Load**

The plots on this page illustrate the side load vs. actuator stroke for the XLB slides. Applied loads will cause a slight deflection of the support rods. Deflection distance is also shown. The graphs include the weight of the support rods and tooling plate and are based on a bearing life equivalent to 10 million inches of travel for dynamic conditions. Higher dynamic loads will reduce cycle life. For static loads, multiply the information in the graph by 1.5.

**NOTE:** Actuator life may vary depending on the severity of the following variables:

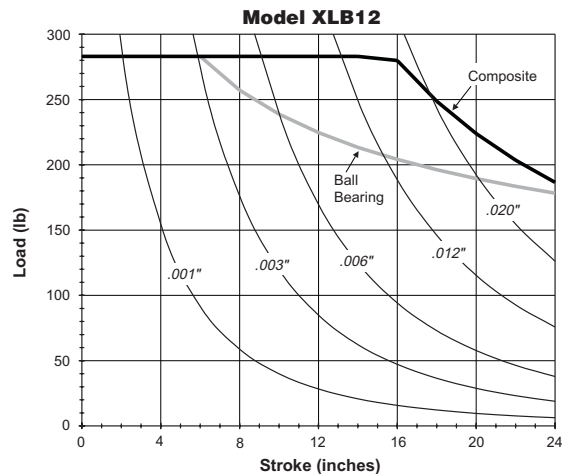
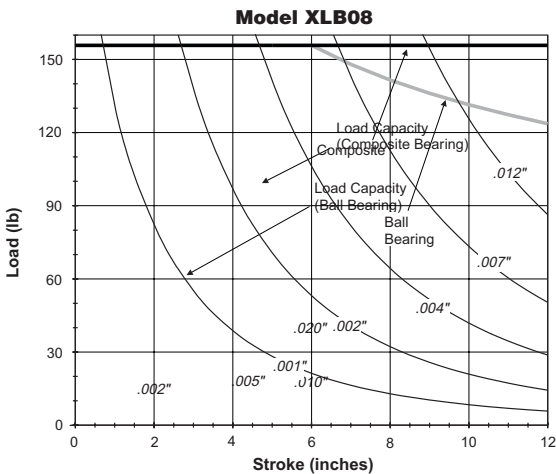
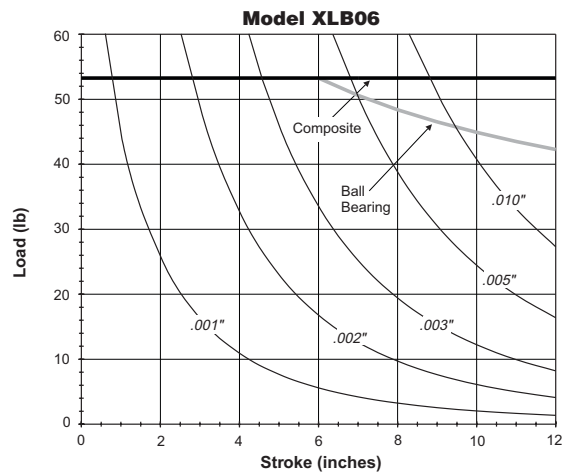
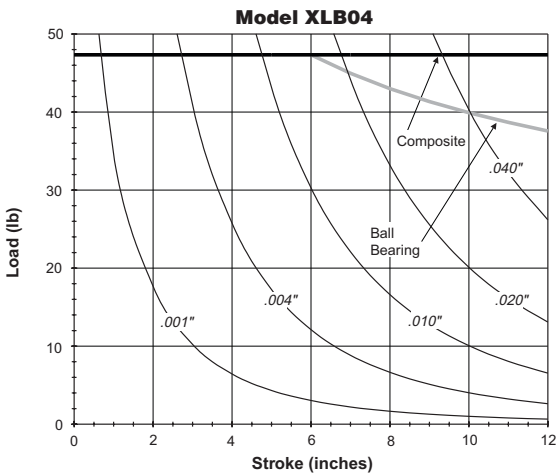
- Acceleration
- Velocity
- Vibration
- Orientation



**EXAMPLE:**

An XLB06 with ball bushings and a stroke of 10" would have a load capacity of 45 lbs.

**Dynamic Horizontal Load Capacity and Deflection vs. Stroke**



Guided Cylinders	P5T Series
	P5L Series
Series	HB Series
	P5E Series
Series	XL Series



For inventory, lead times, and kit lookup, visit [www.pdnplu.com](http://www.pdnplu.com)

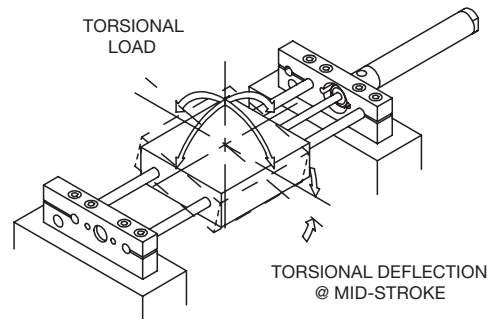


**Symmetrical Torque Capacity**

The plots on this page provide the torsional load vs. actuator stroke for various slide sizes. Torsional loads will cause a slight amount of angular deflection of the tooling plate. Angular deflection is also shown. The data presented is based on a bearing life equivalent to 10 million inches of travel for dynamic conditions. Higher dynamic torques will reduce cycle life. For static torque, multiply the information in the graph by 1.5.

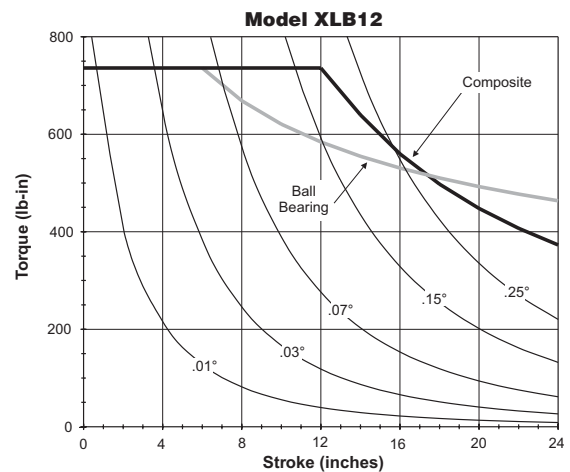
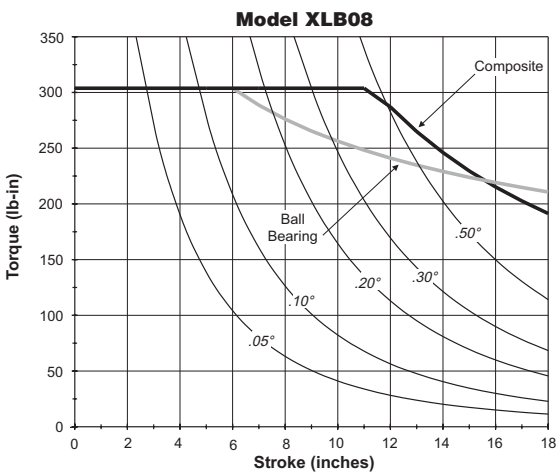
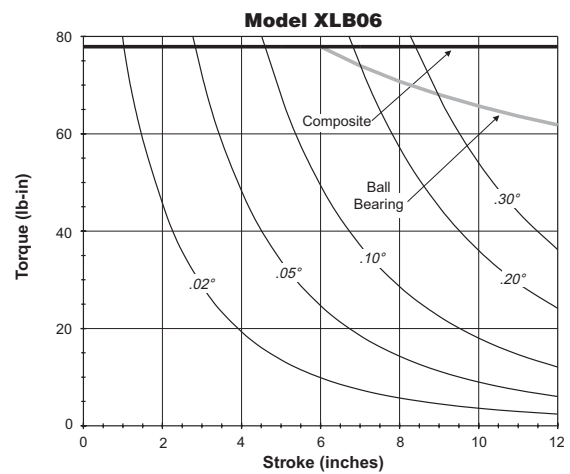
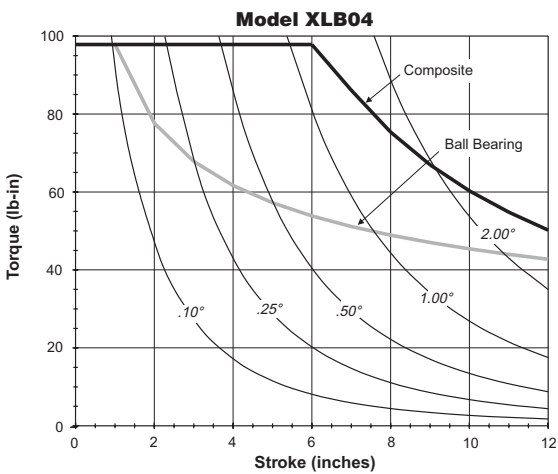
**NOTE:** Actuator life may vary depending on the severity of the following variables:

- Acceleration
- Velocity
- Vibration
- Orientation



**EXAMPLE:**  
 An XLB04 with composite bushings and a stroke of 10" would have a load capacity of 60 in-lbs.

**Symmetrical Torsional Load Capacity and Deflection vs. Stroke**



<b>P</b>	Guided Cylinders
	P5T Series
	P5L Series
	HB Series
	P5E Series
XL Series	



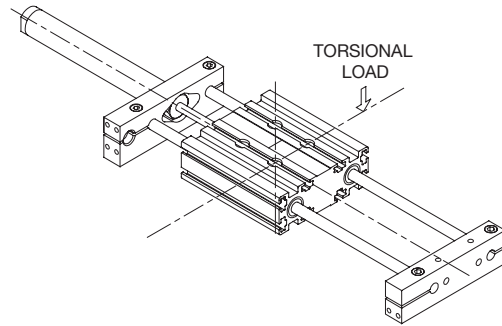
For inventory, lead time, and kit lookup, visit [www.pdnplu.com](http://www.pdnplu.com)

**Asymmetrical Torque Capacity**

Asymmetrical loading occurs when the load is applied to one side of the unit. XLB Series units can resist torsional loads that are asymmetrical. The graphs on this page show torsional load capacity for both composite and linear ball bearings.

**NOTE:** Actuator life may vary depending on the severity of the following variables:

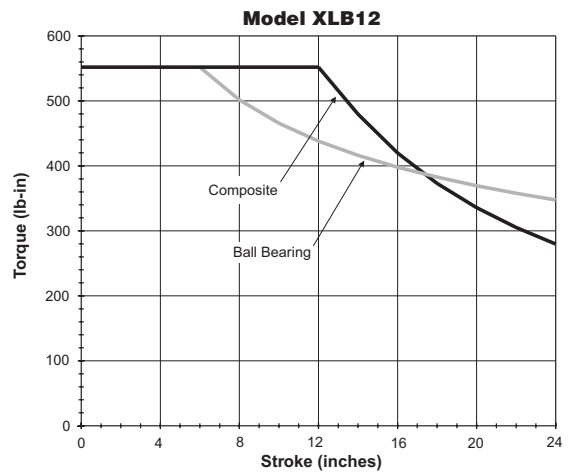
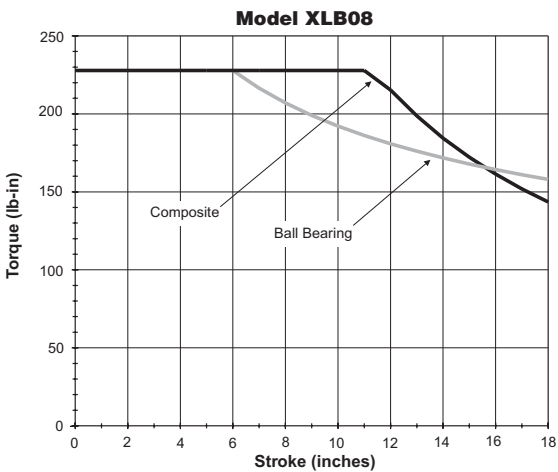
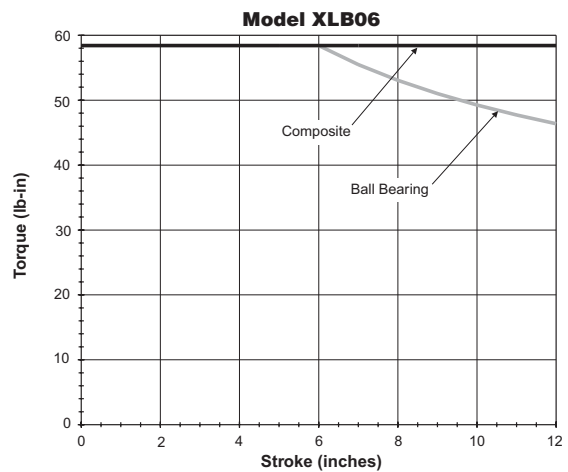
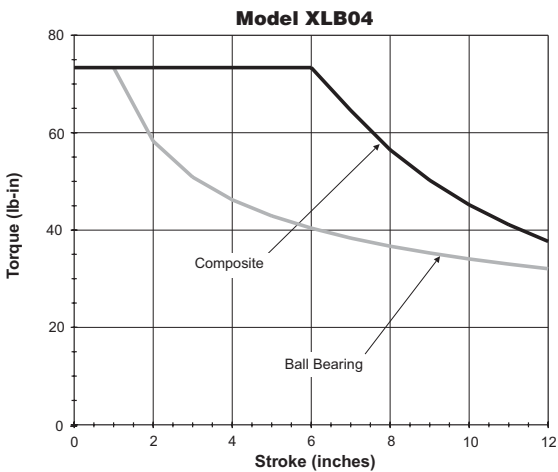
- Acceleration
- Velocity
- Vibration
- Orientation



**EXAMPLE:**

An XLB12 with ball bearings and a stroke of 16" will have an asymmetrical torque capacity of 400 in-lbs.

**Asymmetrical Load Capacity vs. Stroke**



Guided Cylinders	P5T Series
	P5L Series
Series	HB Series
	P5E Series
Series	XL Series



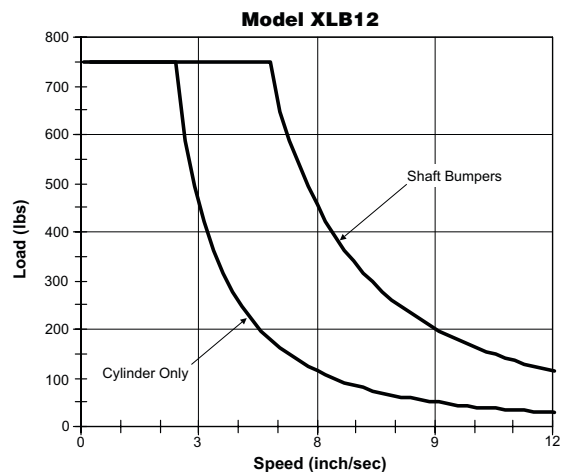
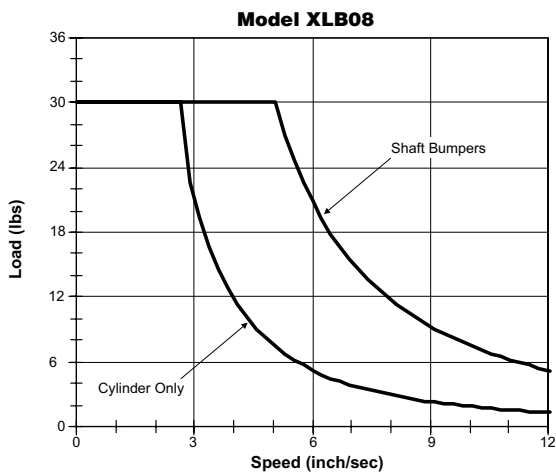
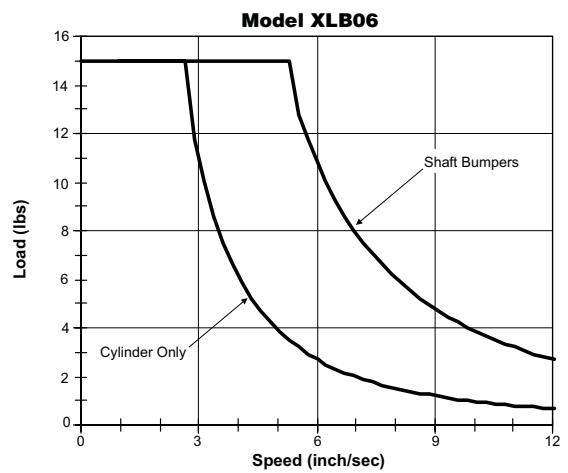
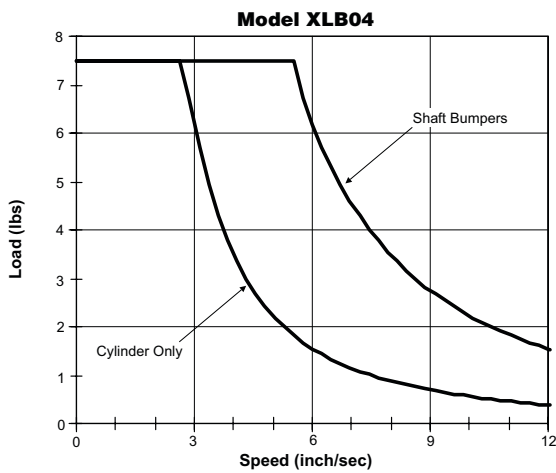
For inventory, lead times, and kit lookup, visit [www.pdnplu.com](http://www.pdnplu.com)

**Kinetic Energy**

These plots illustrate the stopping capacity of the XL Series with bumpers or cylinder only. This type of sizing is based on the weight of the load and the speed at which the load is moving. The bumper plots are based on a 0.020 deflection.

For values above the cushion line, shock absorbers must be specified. Follow the shock absorber sizing steps on the following page to ensure proper stopping capacity.

**NOTE:** These charts are to be used only to determine the stopping capacity of each guided cylinder.



<b>M</b>
Guided Cylinders
P5T Series
P5L Series
HB Series
P5E Series
XL Series



For inventory, lead time, and kit lookup, visit [www.pdnplu.com](http://www.pdnplu.com)

**Kinetic Energy**

Steps to sizing a guided cylinder with shocks:

- 1) Determine the "Moving Weight", W.  
 Use Table 1 to determine the "Kinetic Energy Weight" of a given slide. This value should be added to the weight of the load the slide will be carrying.  
 Moving Weight (lbs) =  
 Kinetic Energy Weight (lbs) + Weight of Load (lbs)
- 2) Determine the velocity of the load, V (ft/second)
- 3) Determine the cylinder force output at the operating pressure, F<sub>cylinder</sub> (lbs)
- 4) Determine the Kinetic Energy of the load:  
 KE = 0.2 × W × V<sup>2</sup> (lb-in)
- 5) Determine the Energy per Cycle, E<sub>cycle</sub> (lb-in):  
 E<sub>cycle</sub> = KE + F<sub>cylinder</sub> × Shock Stroke  
 (unless stroke adjusters are used, 1 inch is standard)  
*This value should be less than the value listed in table 2*
- 6) Determine the Energy per Hour: E<sub>hour</sub> (in-lbs)  
 E<sub>hour</sub> = 2 × E<sub>cycle</sub> × # of cycles in one hour  
 (a cycle is defined as the extension and retraction of the slide)  
*This value should be less than the value listed in table 2*
- 7) Determine the Effective Weight of the load  

$$W_{\text{effective}} = \frac{E_{\text{cycle}}}{0.2 \times V^2}$$
*This value should be between the values listed in table 2*

**Example:**

An HBB20-10D-B with standard support rods and shock absorbers will be carrying a load of 40 lbs at a velocity of 17 in/second (cycling 15 times per hour) while operating at 80 psi. Is this unit properly sized?

- 1) Moving Weight = [8.35 + (10 × 0.65)] + 40 lbs = 54.85 lbs
- 2) V = 17 in/second = 1.4 ft/second
- 3) F<sub>cylinder</sub> = 251 lbs
- 4) KE = 0.2 × 54.85 × 1.42 = 21.5 lb-in
- 5) E<sub>cycle</sub> = 21.5 + 251 = 272.5 lb-in
- 6) E<sub>hour</sub> = 2 × 272.5 × 15 = 8175 lb-in
- 7) 
$$W_{\text{effective}} = \frac{272.5}{0.2 \times (1.4)^2} = 695 \text{ lbs}$$

The shock will dissipate the energy of the load.


**Table 1**

Model	Base weight (lb)	Stroke adder (lb/inch)	Base weight, oversized (lb)	Stroke adder (lb/inch)
HBC15	3.66	0.36	4.36	0.52
HBC20	7.15	0.65	8.19	0.84
HBC25	12.73	1.04	14.19	1.27
HBT15	4.70	0.36	5.67	0.52
HBT20	8.35	0.65	9.67	0.84
HBT25	14.22	1.04	16.01	1.27
HBR15	5.52	0.36	6.96	0.52
HBR20	10.29	0.65	12.46	0.84
HBR25	17.63	1.04	20.66	1.27
HBB15*	7.93	0.09	7.93	0.09
HBB20*	13.94	0.22	13.94	0.22
HBB25*	25.03	0.42	25.03	0.42

\* Support rods do not move with the carriage, so kinetic energy is the same for standard and oversized rods.

**Table 2**

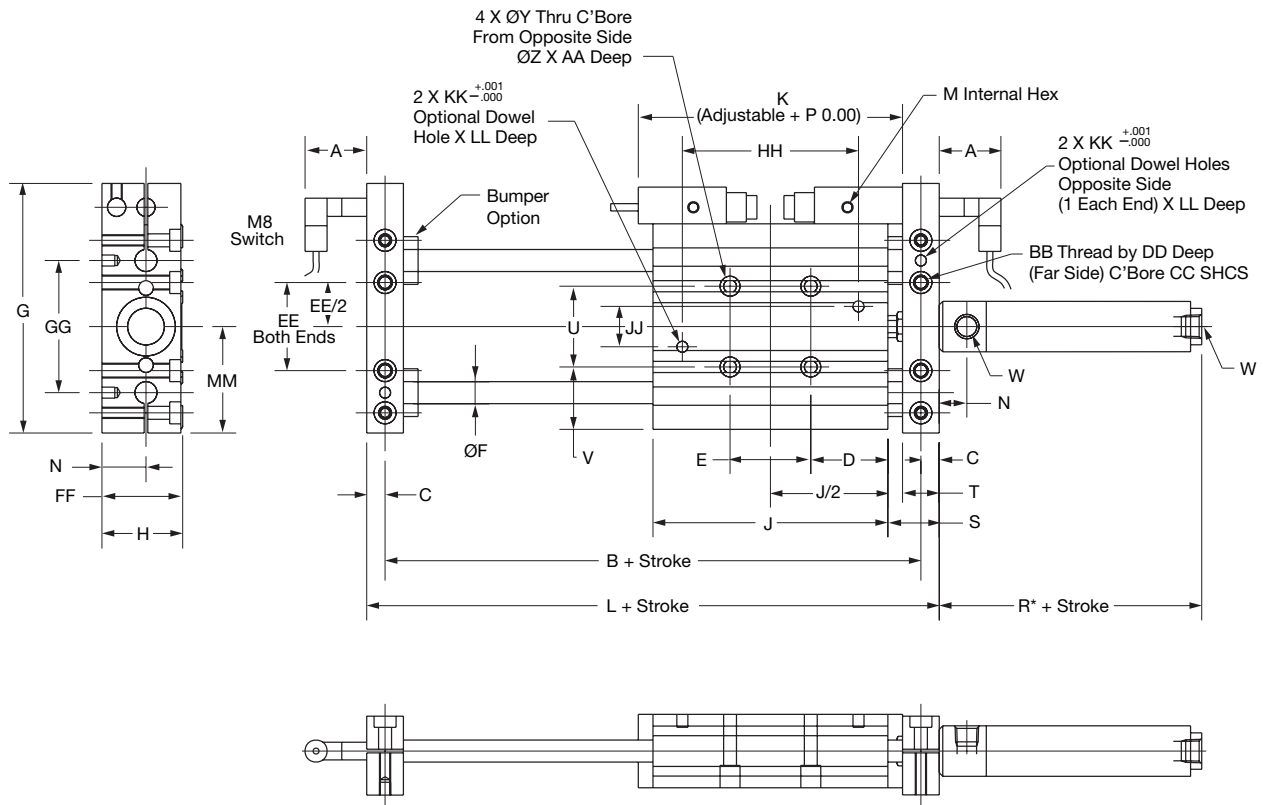
Size	Total energy per cycle (lb-in)	Total energy per hour (lb-in)	Effective weight (lb)	Velocity range (in/sec)
15	600	600,000	20 - 3000	6 - 144
20	900	800,000	30 - 4500	6 - 144
25	1500	670,000	28 - 3800	6 - 120


**Guided Cylinders**  
 P5T Series  
 P5L Series  
 HB Series  
 P5E Series  
 XL Series



For inventory, lead times, and kit lookup, visit [www.pdnplu.com](http://www.pdnplu.com)


**XLB Basic**



Model	A	B	C	D	E	F	G	H	J	K	L	M	N	P	R*	R1	S	T
XLB04	1.18	4.000	.250	1.000	1.000	.250	3.38	1.00	3.00	3.50	4.50	3/32	.40	.50	2.15	2.25	.75	.50
XLB06	1.05	5.125	.313	1.312	1.375	.375	4.25	1.25	4.00	4.50	5.75	3/32	.47	.75	2.47	2.47	.88	.63
XLB08	.92	6.250	.375	1.625	1.750	.500	5.38	1.50	5.00	5.50	7.00	1/8	.57	.75	2.80	2.92	1.00	.75
XLB12	.68	8.000	.500	2.125	2.250	.750	7.00	2.00	6.50	7.00	9.00	1/8	.62	1.25	3.06	3.18	1.25	1.00

Model	U	V	W	Y	Z	AA	BB	CC	DD	EE	FF	GG	HH	JJ	KK	LL	MM	NN
XLB04	1.000	.875	#10-32	.19	.31	.25	#10-32	.28	.38	1.125	1.09	1.750	2.000	.438	.126	.19	1.44	.625
XLB06	1.375	1.063	1/8 NPTF	.22	.34	.38	1/4-20	.38	.50	1.500	1.34	2.250	3.000	.688	.188	.22	1.81	.750
XLB08	1.750	1.375	1/8 NPTF	.28	.44	.38	5/16-18	.44	.63	2.000	1.56	3.000	3.750	.938	.251	.25	2.37	.875
XLB12	2.250	1.875	1/8 NPTF	.34	.53	.50	3/8-16	.53	.75	2.500	2.06	4.000	5.000	1.250	.313	.32	3.06	1.125

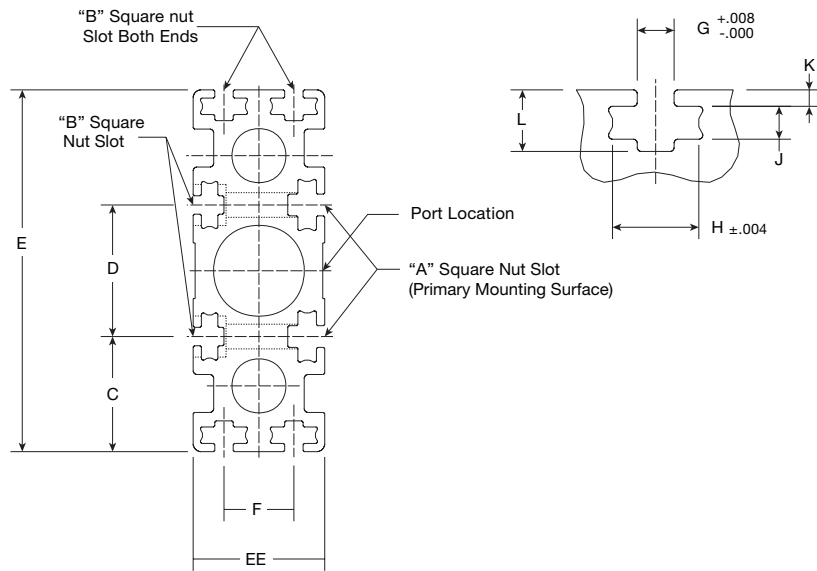
\* Use R1 dimension when bumpers are specified.

  
**Guided Cylinders**  
 P5T Series  
 P5L Series  
 HB Series  
 P5E Series  
 XL Series



For inventory, lead time, and kit lookup, visit [www.pdnplu.com](http://www.pdnplu.com)

**Square Nut “T” Slot**



**Square Nut “T” Slot Dimensions**

Model	Body dimensions							Slot dimensions					
	A	B	C	D	E	EE	F	Slot	G	H	J	K	L
04	8-32	6-32	.875	1.000	2.75	1.00	.531	A	.174	.359	.141	.062	.281
								B	.138	.328	.125	.062	.234
06	10-32	8-32	1.063	1.375	3.50	1.25	.688	A	.190	.391	.141	.094	.312
								B	.164	.359	.141	.094	.312
08	1/4-20	10-32	1.375	1.750	4.50	1.50	.875	A	.250	.453	.203	.125	.438
12	5/16-18	1/4-20	1.875	2.250	6.00	2.00	1.250	A	.312	.578	.234	.156	.563
								B	.250	.453	.202	.125	.438

**Square Nut Kits**

Each slide is equipped with (4) square nuts for the “A” slot and (4) for the “B” slot. Additional square nuts can be ordered. Each kit contains 8 square nuts (4 primary, 4 secondary).

Model	Kit Number
04	NK04
06	NK06
08	NK08
12	NK12

**P**  
 Guided Cylinders  
 P5T Series  
 P5L Series  
 HB Series  
 P5E Series  
 XL Series



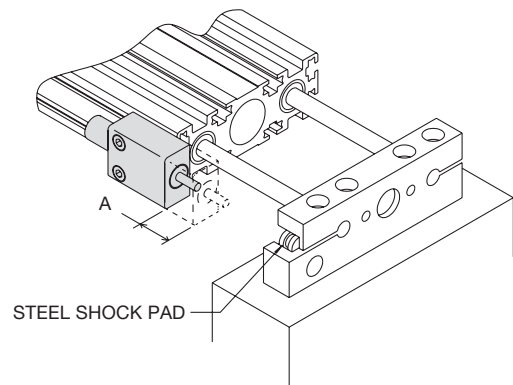
For inventory, lead times, and kit lookup, visit [www.pdnplu.com](http://www.pdnplu.com)

**Options**

**Shock/Stroke Adjuster (A, A1, A2)**

Hydraulic shock absorbers dissipate energy, allowing increased operating speeds. Shocks are fixed orifice self-compensating type and will provide constant deceleration despite changing energy conditions. The shock housing can be used as a stop. By moving the shock housing, the stroke is adjusted. Maximum allowable stroke adjustment is shown in the table.

**NOTE:** Do not allow the shock to protrude through the adjustable stop housing as damage may occur if the shock comes into contact with the tool plate. Additionally, damage may occur if the shock piston rod is twisted or turned



**Shock Ready (A3, A4, A5)**

Shock absorber bracket(s) and tooling plate(s) are provided. Shock may be field added.

**Maximum Allowable Stroke Adjustment per Side**

Model	A
04	0.50
06	0.75
08	0.75
12	1.25

**Bumpers/Adjustable Stop Collars**

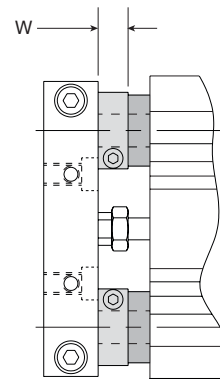
**(B, B1, B2, B3, B4, B5)**

Bumpers absorb shock, reduce noise, and permit faster cycle times thereby increasing production rates. They can be placed on the extend, retract or both positions.

An extend stop collar provides travel adjustment. A stop collar can also be specified for the retract stroke. This stop collar is optional and is only provided if requested. The retract stop collar option (B3) and the stop collar both ends option (B4) reduce the stroke of the slide by the dimension shown.

**EXAMPLE:**

Four inches of stroke are desired with an adjustable stop collar on the retract position. Utilizing the table, a "W" dimension for an 04 size unit would be .28". A 4" stroke unit would have a net stroke of 3.72". If the full 4" of stroke is required, a 5" stroke unit must be ordered. The stops can then be adjusted to provide the desired stroke of 4".



Model	W
04	.281
06	.344
08	.406
12	.500



Guided  
Cylinders

P5T  
Series

P5L  
Series

HB  
Series

P5E  
Series

XL  
Series

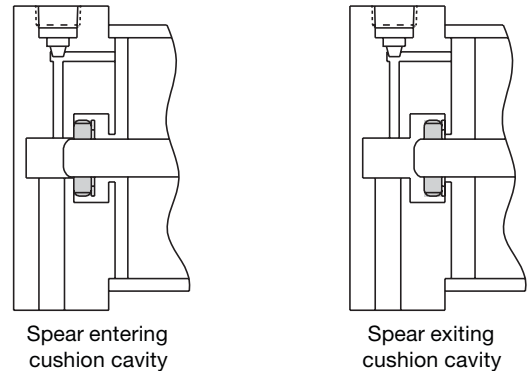


For inventory, lead time, and kit lookup, visit [www.pdnplu.com](http://www.pdnplu.com)

**Options**

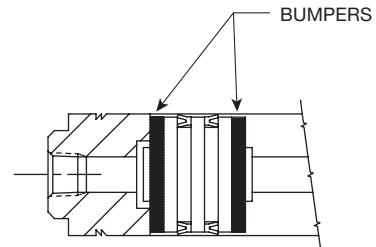
**Cushions on Cylinder (C)**

Optional cylinder cushions are available at both ends. The check seal cushions float radially and longitudinally to compensate for problems with misalignment. Flow paths molded on the circumference of the seal allow exceptionally rapid return stroke without the use of ball checks. A captive cushion screw provides safe cushion adjustment while the cylinder is pressurized. The brass adjustment screw provides maximum corrosion resistance. The cushion adjustment screw is hidden by the XL housing. The cushion adjustment screw is factory set at full cushion less 1/2 of a turn



**Bumpers on Cylinder (D)**

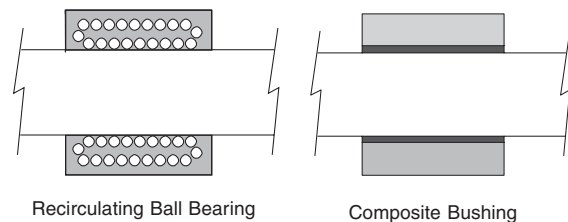
Available on both ends only, bumpers may be specified on the cylinder to reduce noise. Bumpers add length to the cylinder. See Dimensional Data for "R1" length.




**Composite Bushings (T)**

Selection should be based on the following criteria:

Application Requirement	Ball Bearing	Composite
Precision	Excellent	Good
Friction	Low	Higher
Friction Coefficient	Constant	Variable
Precision over Life of Bearing	Constant	Variable
Static Load Capacity	Good	Excellent
Dynamic Load Capacity	Good	Good with lower efficiency
Lubrication	Required	Not Required
Vibration Resistance	Fair	Excellent
Contamination Resistance	Fair	Excellent
Washdown Compatibility	Poor	Excellent



For bushing load capacities, reference the Engineering Data pages of this section.


**Guided Cylinders**  
 P5T Series  
 P5L Series  
 HB Series  
 P5E Series  
 XL Series



For inventory, lead times, and kit lookup, visit [www.pdnplu.com](http://www.pdnplu.com)

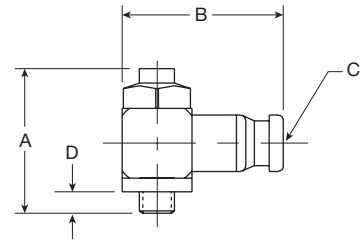


**Options**

**Flow Controls (F, G)**

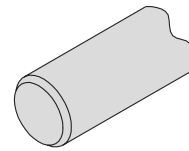
Right angle flow control valves allow precise adjustment of cylinder speed by metering exhaust air flow. Prestolok push-in or NPT ports provide 360° orientation capability.

Model	A	B		C		D	Thickness
		Prestolok	NPT	Prestolok	NPT		
04	1.63	1.38	1.18	5/32	N/A	.16	.67
06	1.63	1.38	1.18	5/32	1/8	.44	.67
08	1.63	1.38	1.18	1/4	1/8	.44	.67
12	1.63	1.38	1.18	1/4	1/8	.44	.67



**Stainless Steel Shafts (K)**

Case-hardened, high carbon alloy steel shafting is utilized for standard slides. Stainless steel shafting can be specified for corrosive applications.



**Fluorocarbon Piston Seals (V)**

Standard abrasion resistant nitrile seals should be used for general purpose applications with temperatures of 0 to 165°F. Fluorocarbon seals are recommended for high temperature applications up to 250°F.

Option	Temperature range* (°F)
Shock Absorbers	32 to 150
Bumpers	0 to 200
Piston Magnets	0 to 165
Switches	14 to 140

\*Consult factory for higher temperature operation.

**Dowel Pin Holes (E)**

See Basic Dimensions for location



Guided  
Cylinders

P5T  
Series

P5L  
Series

HB  
Series

P5E  
Series

XL  
Series



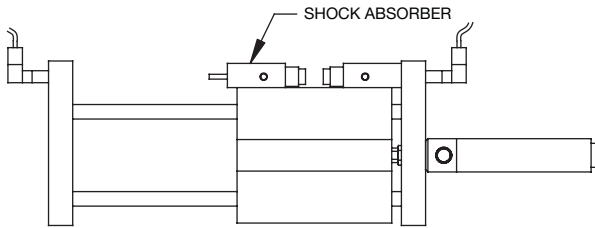
For inventory, lead time, and kit lookup, visit [www.pdnplu.com](http://www.pdnplu.com)

**Options**

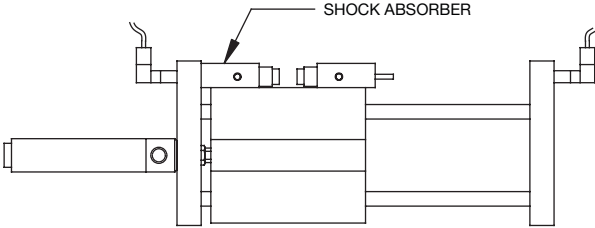
**XLB Series Left Hand Assembly (L)**

When shock absorbers or proximity sensors are specified, units are shipped with the cylinder mounted on the right hand side of the slide when viewing the cylinder port. The shocks or sensors are located on the upper right and left. The slide can be ordered with the cylinder on the opposite side by specifying an "L" in the model number.

**STANDARD ORIENTATION**



**LEFT HAND ORIENTATION**



**Three Position Unit**

The three position unit utilizes a duplex air cylinder to provide the center position. This option can be specified with all other options. However, shock absorbers, bumpers and body mounted inductive proximity sensors operate on the fully extended and retracted positions only. Cylinder mounted reed and Hall Effect switches detect the center position of the slide.

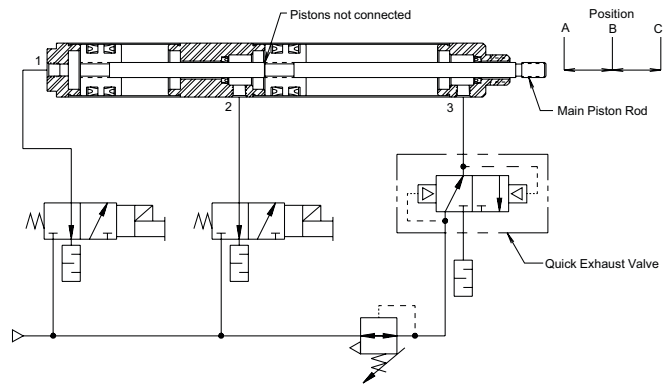
**Operation:**

Position A (fully retracted) is obtained by applying pressure to Port 3 with Ports 2 and 1 vented to atmosphere. Position B (mid-position) is obtained by applying pressure to Port 1 while maintaining a lower pressure to Port 3. The pressure at Port 3 prevents the main piston rod from over-travel.

A quick exhaust valve can be used to maintain pressure while allowing full exhaust capability. Position C (fully extended) is obtained by applying pressure to Port 2.

**Dimensional Data:**

Three position units utilize a longer cylinder. All other dimensions remain the same.

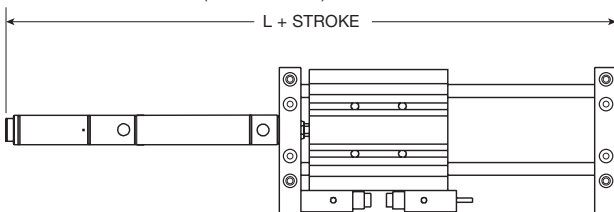


**Maximum Stroke for Intermediate Position**

Model	Stroke
04	3
06	6
08	9
12	12

Model	L
04	8.86
06	10.95
08	12.70
12	15.33

Stroke = (2 x total stroke) + intermediate stroke



Guided  
Cylinders

P5T  
Series

P5L  
Series

HB  
Series

P5E  
Series

XL  
Series



For inventory, lead times, and kit lookup, visit [www.pdnplu.com](http://www.pdnplu.com)

**Options**

**Switch Characteristics**

**Proximity Sensors**

- End of stroke sensing
- Solid state electronics
- LED indicator on plug-in style switch
- 10-30 VDC
- PNP and NPN available
- Senses metal tool plate
- Highest cost
- Long life

**Hall Effect Switches**

- Fully adjustable travel
- Solid state electronics
- LED indicator
- 6-30 VDC
- PNP and NPN available
- Senses magnet on cylinder piston
- Medium cost
- Long life

**Reed Switches**

- Fully adjustable travel
- Mechanical reed
- LED indicator
- 6-30 VDC or 85-150 VAC
- Senses magnet on cylinder piston
- Lowest cost
- Medium life

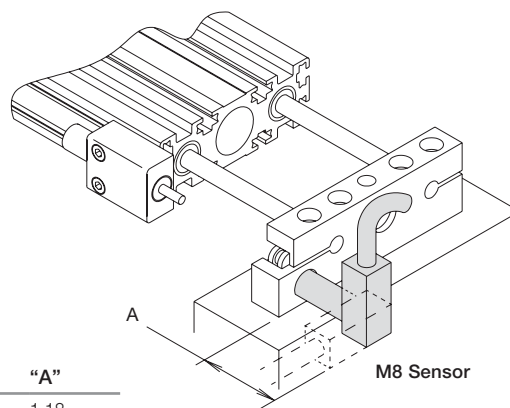
**Proximity Sensors**

Proximity sensors sense the extend and retract positions of the slide. The proximity sensor is attached to the end mounting plate and remains in the proper position even when the stroke is adjusted. The sensor is pre-set at the factory and does not require adjustment. Should adjustment be necessary, care should be taken to ensure that the sensor does not come into contact with the stroke adjust stop block. Distance from the stop block to the sensor should be approximately .016 inches.

**NOTE:** When proximity sensors are specified with bumpers/adjustable stop collars, the sensor is mounted on the slide housing.

**Electrical Specifications**

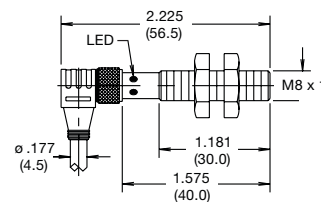
Voltage:	10-30 VDC (3 wire) PNP or NPN
No load current:	5.5-9.5 mA
Continuous current:	150 mA
Switching speed:	8 ms
Switch frequency:	5000 Hz
Switching distance:	Aluminum = 0.016 in (0.4mm) Brass = 0.028 in (0.7mm) Steel = 0.039 in (1.0mm)
Overload protection:	Triggered at 170 mA
Reverse polarity protection:	Incorporated
Temperature range:	-13 to 158°F (-25 to 70°C)
Enclosure:	Meets NEMA 1,3,4,6,13 and IEC IP67, fully encapsulated



Model	"A"
XLB04	1.18
XLB06	1.05
XLB08	0.92
XLB12	0.68

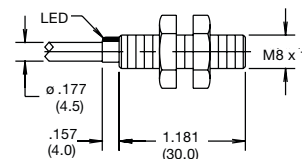
**Plug-in sensor (P1, N1)**

A threaded right angle cordset is included as standard. The cordset contains two LEDs: 1- power, 2 - target indication. Cordset length is 20 ft. (6m).

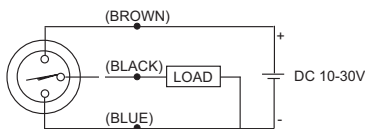


**Potted-in sensor (P, N)**

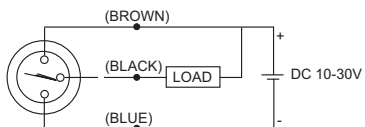
Lead type sensor with 20 ft. (6m) cord length



**PNP WIRING CONNECTION**



**NPN WIRING CONNECTION**



**M**

Guided  
Cylinders

---

P5T  
Series

---

P5L  
Series

---

HB  
Series

---

P5E  
Series

---

XL  
Series

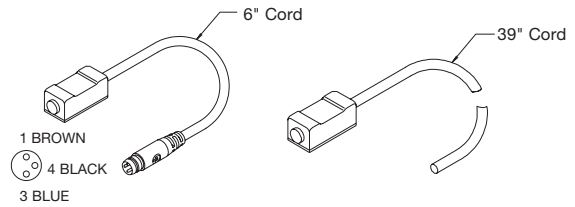


For inventory, lead time, and kit lookup, visit [www.pdnplu.com](http://www.pdnplu.com)

**Options**

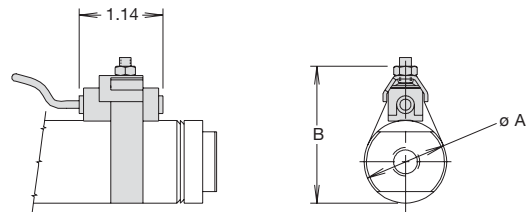
**Switches (order separately)**

Description	Part number
PNP Hall Effect w/6" male plug-in connector	<b>146715000C</b>
NPN Hall Effect w/6" male plug-in connector	<b>146714000C</b>
PNP Hall Effect w/39" potted-in leads	<b>1467150000</b>
NPN Hall Effect w/39" potted-in leads	<b>1467140000</b>
Reed switch w/6" male plug-in connector	<b>145903000C</b>
Reed switch w/39" potted-in leads	<b>1459030000</b>



**Switch Clamps (order separately)**

Model	ØA	B	Part number
04	0.62	1.35	<b>L074730056</b>
06	0.86	1.60	<b>L074730075</b>
08	1.12	1.86	<b>L074730106</b>
12	1.56	2.30	<b>L074730150</b>



**Cordset With Female Quick Connect (order separately)**

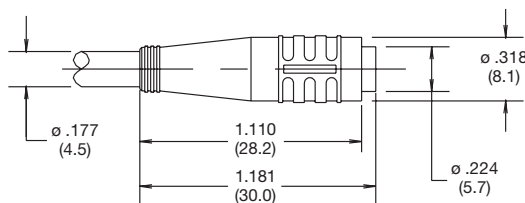
A female connector is available for all switches with the male quick connect option. The male plug will accept a snap-on or threaded connector. Parker's cordset part numbers and other manufacturer's part numbers are listed below:

Manufacturer	Threaded Connector	Snap-On Connector
Parker	<b>B8786</b>	<b>B8785</b>
Brad Harrison	<b>45310-102</b>	<b>45300-102</b>
Lumberg	<b>RKMV3-G1/5m</b>	<b>RKM3-G1/5m</b>
Hirschmann	—	<b>ELKA-K308PUR014</b>
Turck	<b>PKG 3M-6/S90</b>	<b>PKG 3-6/S90</b>

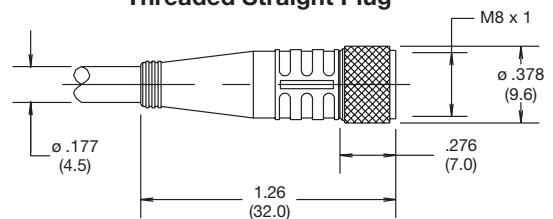
**Cordset Specifications:**

Connector:	Oil resistant polyurethane body material, PA 6 (Nylon) contact carrier, spacings to VDE 0110 Group C, (30 VAC/36 VDC)
Contacts:	Gold plated beryllium copper, machined from solid stock
Coupling method:	Snap-Lock or chrome plated brass nut
Cord construction:	Oil resistant black PUR jacket, non-wicking, non-hygroscopic, 300V. Cable end is stripped and tinned.
Conductors:	Extra high flex stranding, PVC insulation
Temperature:	-40 to 194°F (-40 to 90°C)
Protection:	NEMA 1,3,4,6P and IEC IP67
Cable length:	20 ft. (6m.)

**Snap-on Straight Plug**



**Threaded Straight Plug**



For inventory, lead times, and kit lookup, visit [www.pdnplu.com](http://www.pdnplu.com)

E160

**Parker Hannifin Corporation**  
 Pneumatic Division  
 Richland, Michigan  
[www.parker.com/pneumatics](http://www.parker.com/pneumatics)

**Options**

**Switch Specifications**

**Hall Effect Switches**

Type:	Solid State (PNP or NPN)
Switching Logic:	Normally Open
Supply Voltage Range:	6 - 30 VDC
Current Output Range:	Up to 100 mA at 5 VDC, Up to 200 mA at 12 VDC and 24 VDC
Current Consumption:	7 mA at 5 VDC, 15 mA at 12 VDC, and 30 mA at 24 VDC
Switching Frequency:	1000 Hz Maximum
Residual Voltage:	1.5V Maximum
Leakage Current:	10uA Maximum
Breakdown Voltage:	1.8kVACrms for 1 sec., lead to case
Min. Current for LED:	1 mA
Operating Temperature:	14 to 140°F (-10 to 60°C)
Enclosure Protection:	Meets IEC IP67, fully encapsulated
Lead Wire:	3 conductor, 24 gauge
Lead Wire Length:	39 in (1m)
Vibration Resistance:	10-55 Hz, 1.5mm double amplitude

**Reed Switches**

Switching Logic:	Normally open, SPST
Voltage Rating:	85-125 VAC or 6-30 VDC*
Power Rating:	10 Watts AC or DC/resistive load 5 Watts AC or DC/inductive load
Switching Current Range:	30-200 mA/resistive load (PC, sequencer) 30-100 mA/inductive load (relay)
Switching Frequency:	300 Hz maximum
Breakdown Voltage:	1.8kVACrms for 1 sec., lead to case
Min. Current for LED:	18 mA
Operating Temperature:	14 to 140°F (-10 to 60°C)
Enclosure Protection:	Meets IEC IP67, fully encapsulated
Lead Wire:	2 conductor, 22 Gauge
Lead Wire Length:	39 in (1m)
Vibration Resistance:	10-55 Hz, 1.5mm double amplitude

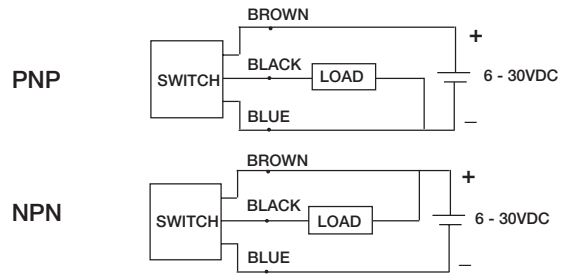
\* Polarity is restricted for DC operation

(+) to Brown

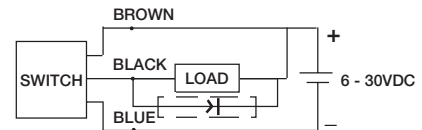
(-) to Blue

If these connections are reversed, the contacts will close but the LED will not light.

**WIRING CONNECTION**



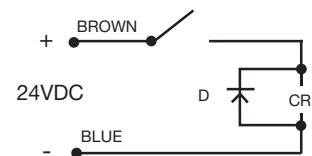
**PROTECTION CIRCUIT\***



\* When connecting an inductive load (relay, solenoid valve, etc.), a protection circuit is recommended. Use a 100V, 1A diode. (NPN connection shown.)

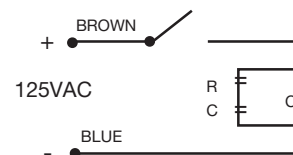
**PROTECTION CIRCUIT (INDUCTIVE LOADS)**

(Required for proper operation 24VDC)  
 Select a diode with a breakdown voltage and current rating according to the load. Place a diode in parallel to the load with the polarity as indicated:



CR: Relay coil (under 0.5W coil rating)

(Recommended for longer switch life 125VAC)  
 Select a resistor and capacitor according to the load. Place a resistor and capacitor in parallel to the load:




CR: Relay coil (under 2W coil rating)  
 R: Resistor under 1 K ohm  
 C: Capacitor 0.1 μF



For inventory, lead time, and kit lookup, visit [www.pdnplu.com](http://www.pdnplu.com)




Guided Cylinders
P5T Series
P5L Series
HB Series
P5E Series
XL Series



For inventory, lead times, and kit lookup, visit [www.pdnplu.com](http://www.pdnplu.com)

E162

**Parker Hannifin Corporation**  
Pneumatic Division  
Richland, Michigan  
[www.parker.com/pneumatics](http://www.parker.com/pneumatics)



## Automation Products Pneumatic

<b>Product Overview</b>	F2
-------------------------	----

### Grippers

<b>Gripper Selection</b>	F3
<b>Angular Gripper</b>	
P5GA Series - Economy	F4-F5
<b>Parallel Gripper</b>	
P5GB Series - Economy	F6-F7
P5GV Series - Miniature Clean Room	F8-F9
P5GR Series - High Precision	F10-F12
P5GU Series - Clean Room, Harsh Environment	F13-F15
P5GN Series - Compact Parallel	F16-F18
P5GM Series - Parallel	F19-F21
P5GS Series - Wide Body	F22-F24
P5GT Series - Double Wedge	F25-F27
<b>Electric Gripper</b>	
P5GP Series	F28-F29
P5GQ Series - High Force	F30-F31
<b>3-Jaw Gripper</b>	
P5GW Series	F32-F35

### Slide Tables

P5SS Series - Linear	F36-F47
----------------------	---------

### Rotary Tables

P5RS Series - Rotary	F48-F49
----------------------	---------

### Escapements

P5MD Series	F50-F51
-------------	---------

### Sensors & Fittings

Sensors	F52-F55
Fittings	F56

## Complete Automation Solution

Parker Pneumatic Division is a single source supplier for all your automation needs. Selecting the right product for your application is easy with Parker Hannifin's extensive offering of pneumatic grippers, slide tables, rotary tables, and escapements. Integration into your automation system is fast and simple using a variety of online e-configurators and CAD drawings.

**Extensive Offering.**

**Easy Integration.**

**Single Source.**

## Features and Benefits

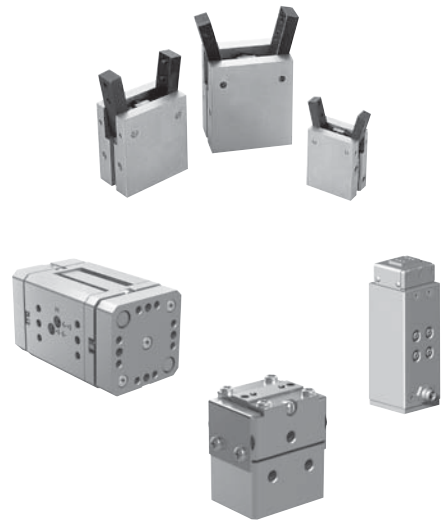
### Hold

#### Economy grippers

- Cost effective solution for machine builders
- Angular and Parallel
- 12mm to 32mm bore

#### Precision grippers

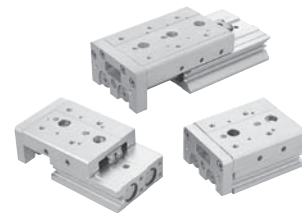
- Premium product for precision and durability
- Repeatability to + 0.00005mm
- Parallel 2 and 3 jaw
- Strokes to 73.5mm
- Grip forces to 44,000 N
- Clean room
- Electric grippers



### Index

#### Slide tables

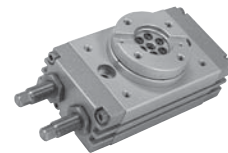
- Built in linear rail
- Bore size 6-25mm
- Available with stroke adjusters and shock absorbers



### Rotate

#### Rotary table

- Twin rack and pinion rotary with integrated table
- Rotation adjustment standard 0-190 degrees
- Available with shock absorbers
- Hollow shaft standard for wiring and piping



### Feed

#### Escapements

- Most effective mechanism for separating parts fed from conveyor
- Thrust force to 400 N
- Adjustable retract





**Grippers**

	Series	Type	Grip force max.	mm or degrees of stroke	Spring open	Spring close	Clean room	Page number
	<b>P5GA</b>	Angular	13 N to 194 N	-10° to 30°	No	No	No	F5
	<b>P5GB</b>	Parallel	16 N to 130 N	6mm to 16mm	No	No	No	F7
	<b>P5GV</b>	Parallel	36 N	3.2mm to 6.3mm	No	No	Yes	F9
	<b>P5GR</b>	Parallel	120 N to 458 N	6.4mm to 38.1mm	No	Yes	Yes	F11
	<b>P5GU</b>	Parallel	116 N to 160 N	6.5mm to 25.4mm	No	No	Yes	F14
	<b>P5GN</b>	Parallel	62 N to 445 N	1.6mm to 9.5mm	No	No	Yes	F17
	<b>P5GM</b>	Parallel	62 N to 445 N	4.8mm to 25.4mm	No	No	Yes	F20
	<b>P5GS</b>	Parallel	222 N to 800 N	19.1mm to 73.5mm	No	No	No	F23
	<b>P5GT</b>	Parallel	178 N to 2669 N	6.4mm to 50.8mm	No	No	No	F26
	<b>P5GP</b>	Electric	111 N	0mm to 25mm	No	No	No	F29
	<b>P5GQ</b>	Electric	445 N to 1334 N	10mm to 20mm	No	No	No	F31
	<b>P5GW</b>	3-Jaw	682 N to 44354 N	4.0mm to 35mm	No	Yes	Yes	F33



Automation Products

Grippers

Slide Tables

Rotary Tables

Escapements

Sensors & Fittings



For inventory, lead time, and kit lookup, visit [www.pdnplu.com](http://www.pdnplu.com)

**Features**

**P5GA Angular Gripper Series, Economy**

- Angular gripper, 2-finger - economy
- Comprehensive range of bore sizes, 12mm to 32mm
- Magnetic piston standard



Operating information	
Operating pressure:	1.5 to 7 bar (21.8 to 102 PSIG)
Temperature range:	-5° to 60° C (23° to 140° F)
Maximum frequency:	180 cycles/min

**Ordering Information: P5GA Angular Gripper Series - Economy**

Function	Bore size (mm)	Ports (BSPP)	Rotation	Weight (g)	Part number
Double acting magnetic	12	M3	-10 to 30 degrees	53	<b>P5GA-012MSG030B</b>
Double acting magnetic	16	M5	-10 to 30 degrees	103	<b>P5GA-016MSG030B</b>
Double acting magnetic	20	M5	-10 to 30 degrees	193	<b>P5GA-020MSG030B</b>
Double acting magnetic	25	M5	-10 to 30 degrees	327	<b>P5GA-025MSG030B</b>
Double acting magnetic	32	M5	-10 to 30 degrees	525	<b>P5GA-032MSG030B</b>

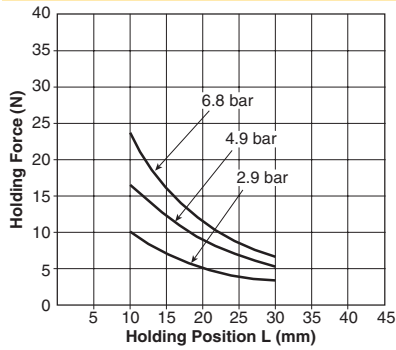
Sensor part numbers: Page F52.

<b>Automation Products</b>
<b>Grippers</b>
<b>Slide Tables</b>
<b>Rotary Tables</b>
<b>Escapements</b>
<b>Sensors &amp; Fittings</b>

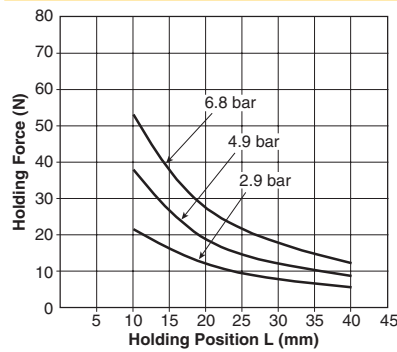


For inventory, lead times, and kit lookup, visit [www.pdnplu.com](http://www.pdnplu.com)

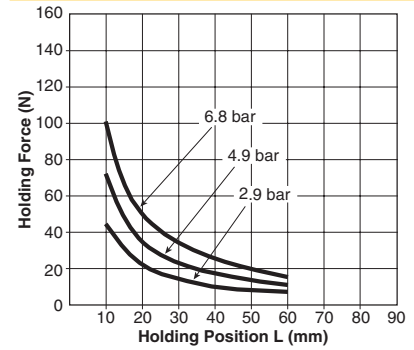
**Clamp Force - P5GA-012**



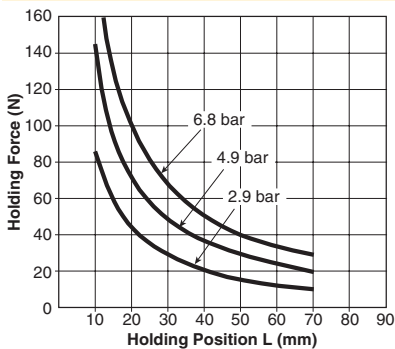
**Clamp Force - P5GA-016**



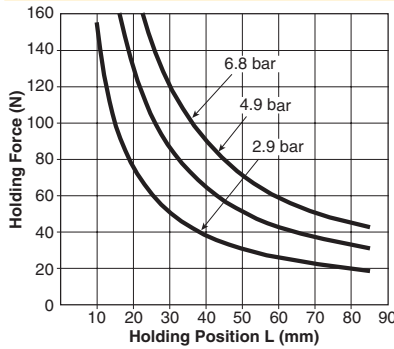
**Clamp Force - P5GA-020**



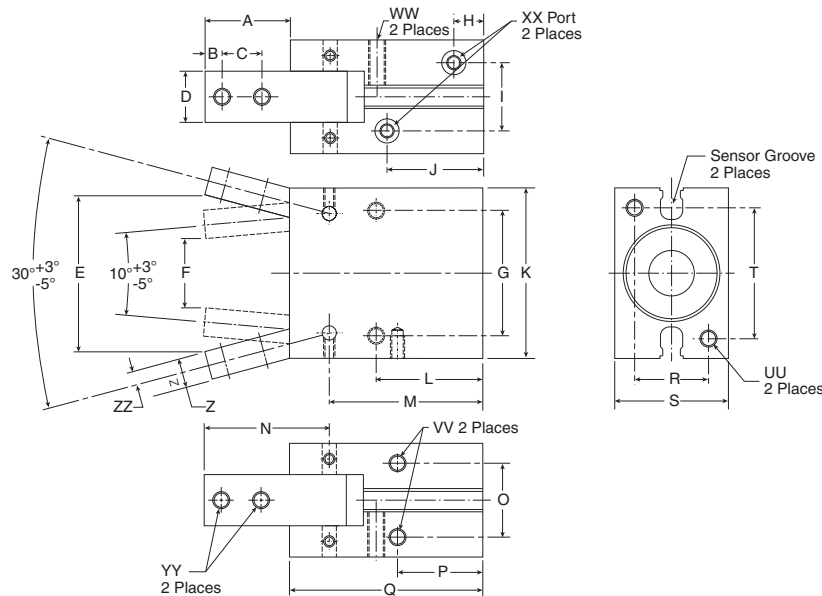
**Clamp Force - P5GA-025**



**Clamp Force - P5GA-032**



**Dimensions: P5GA Angular Gripper Series - Economy**



Tube I.D.	A	B	C	D	E	F	G	H	I	J	K	L	M	N	O	P	Q	R	S	T	UU	W	WW	XX	YY	Z	ZZ
12	15.4	3	6	7	26.3	9	20	7.5	10.2	23.5	28	20	32.9	21.5	10.2	16	39	10	16	22	M3	M3	M3	M3	M3	5	2.5
16	17.5	3	8	9	31.1	14	24	7.5	12	22	34	22.5	35	25	14	18	42.5	14	22	26	M4	M4	M4	M5	M3	6	3
20	22	4	10	12	40.1	18	30	8	13	25	45	25	39.5	32.5	16	19	50	16	26	35	M5	M5	M5	M5	M4	7	3.5
25	26	5	12	14	47.9	21	36	8.5	18	28	52	28.5	45.5	38.5	20	21.5	58	20	32	40	M6	M6	M6	M5	M5	9	4
32	30	6	14	18	55.1	24	44	10.5	24	34	60	37.5	54	44	26	30	68	26	40	46	M6	M6	M6	M5	M6	10	5

Dimensions in millimeters

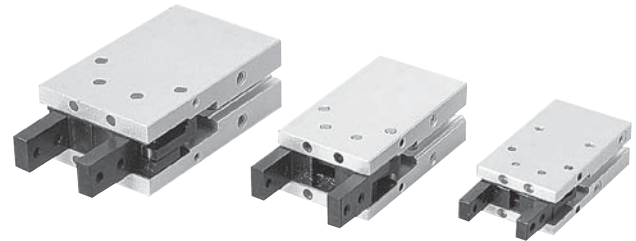


For inventory, lead time, and kit lookup, visit [www.pdnplu.com](http://www.pdnplu.com)

**Features**

**P5GB Parallel Gripper Series, Economy**

- Parallel gripper, 2-finger - economy
- Comprehensive range of bore sizes, 12mm to 32mm
- Magnetic piston standard



**Operating information**

Operating pressure: 1.5 to 7 bar (21.8 to 102 PSIG)  
 Temperature range: -5° to 60° C (23° to 140° F)  
 Maximum frequency: 180 cycles/min

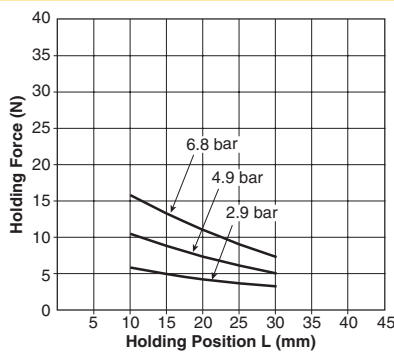
**Ordering Information: P5GB Parallel Gripper Series - Economy**

Function	Bore size (mm)	Ports (BSPP)	Stroke (mm)	Weight (g)	Part number
Double acting magnetic	12	M3	6	66	<b>P5GB-012MSG006B</b>
Double acting magnetic	16	M5	8	144	<b>P5GB-016MSG008B</b>
Double acting magnetic	20	M5	12	255	<b>P5GB-020MSG012B</b>
Double acting magnetic	25	M5	14	419	<b>P5GB-025MSG014B</b>
Double acting magnetic	32	M5	16	719	<b>P5GB-032MSG016B</b>

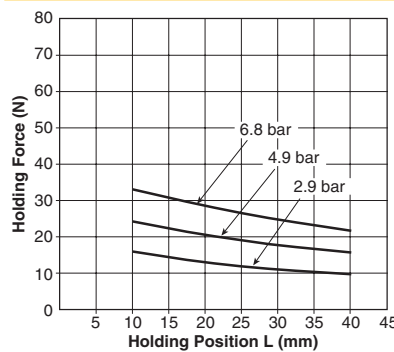
Sensor part numbers: Page F52.

Automation Products  
 Grippers  
 Slide Tables  
 Rotary Tables  
 Escapements  
 Sensors & Fittings

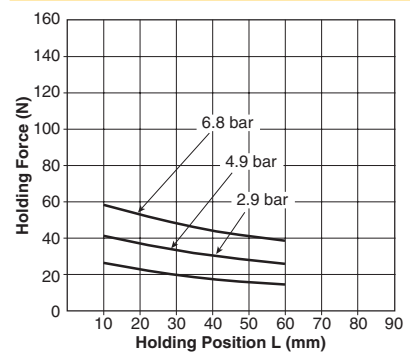
**Clamp Force - P5GB-012**



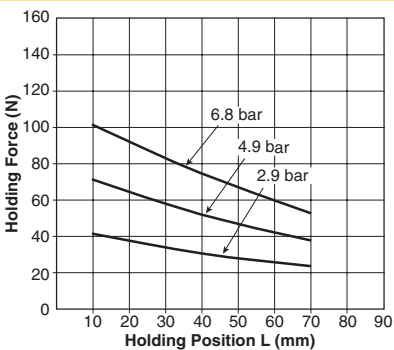
**Clamp Force - P5GB-016**



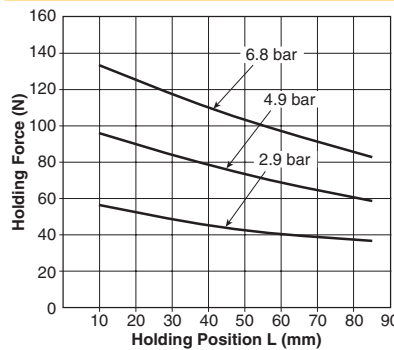
**Clamp Force - P5GB-020**



**Clamp Force - P5GB-025**



**Clamp Force - P5GB-032**

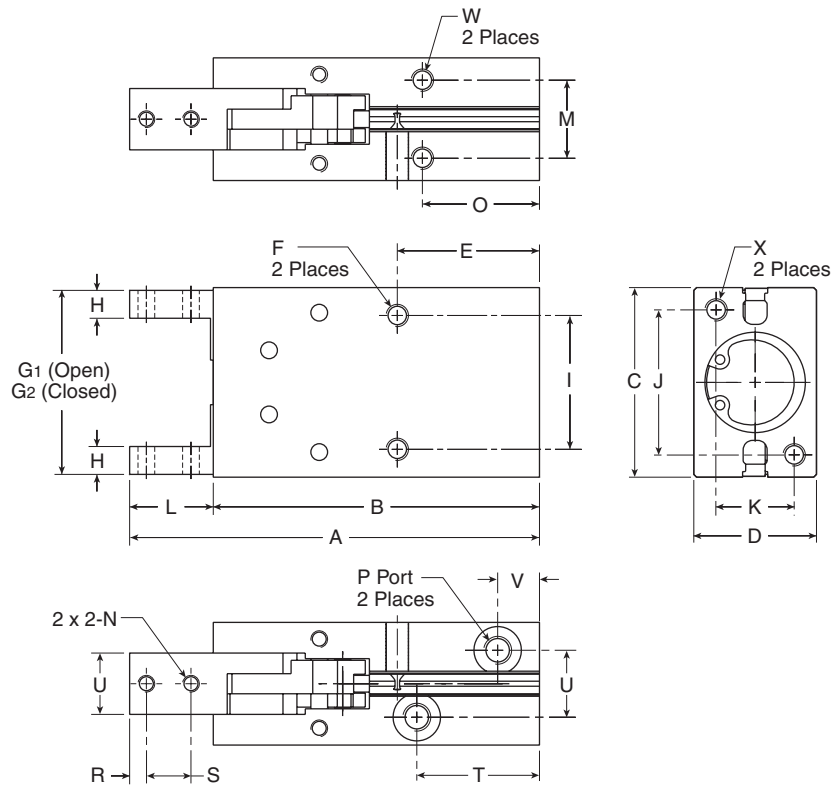


☐ Most popular.



For inventory, lead times, and kit lookup, visit [www.pdnplu.com](http://www.pdnplu.com)

**Dimensions: P5GB Parallel Gripper Series - Economy**



Tube I.D.	A	B	C	D	E	F	G1	G2	H	I	J	K	L	M	N	O	P	Q	R	S	T	U
12	63.5	50.5	28	16	20	M3 x 0.5 x 5 Dp	27	21	4	18	17	10	13	10	M3 x 0.5	16	M3	7	3	6	23	10.2
16	73.5	58.5	34	22	25.5	M4 x 0.7 x 11 Dp	33	25	5	24	26	14	15	14	M3 x 0.5	21	M5	11	3	8	22	12
20	88.5	69.5	45	26	25	M5 x 0.8 x 8 Dp	44	32	6	30	35	16	19	16	M3 x 0.7	19	M5	12	4	10	26	13
25	102.5	78.5	52	32	28	M6 x 1.0 x 10 Dp	51	37	8	36	40	20	24	20	M3 x 0.8	22	M5	14	5	12	29	18
32	120.5	90.5	60	40	34	M6 x 1.0 x 10 Dp	59	43	10	44	46	24	30	26	M3 x 1.0	26	M5	20	7	15	35	24

Tube I.D.	V	W	X
12	7.5	M3 x 0.5 x 5 Dp	M3 x 0.5 x 5 Dp
16	7.5	M4 x 0.7 x 7 Dp	M4 x 0.7 x 7 Dp
20	8	M5 x 0.8 x 8 Dp	M5 x 0.8 x 8 Dp
25	8.5	M6 x 1.0 x 10 Dp	M6 x 1.0 x 10 Dp
32	10.5	M6 x 1.0 x 10 Dp	M6 x 1.0 x 10 Dp

Dimensions in millimeters



Automation Products

Grippers

Slide Tables

Rotary Tables

Escapements

Sensors & Fittings

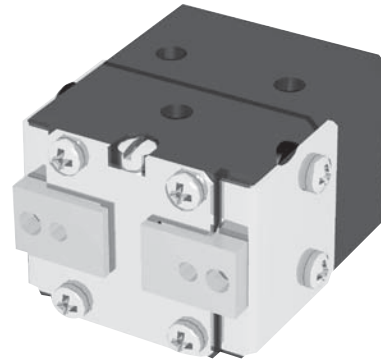


For inventory, lead time, and kit lookup, visit [www.pdnplu.com](http://www.pdnplu.com)

**Features**

**P5GV Parallel Clean Room Series, Miniature**

- One piece lightweight aluminum body
- Stationary and non-contacting stainless steel cover eliminates the possibility of particle generation
- Bearings are preloaded for maximum support and zero side play
- The body has hard-coat anodize 60 RC with PTFE impregnation
- Units are lubricated with a clean-room grade grease
- Purge / scavenge port for extreme environments from dirty and gritty to clean-room class 10 or better
- Adjustable preload screw allows for adjustment of preload on roller bearings
- External components are made from corrosion resistant materials for resistance to de-ionized water or for use in FDA and medical parts handling applications
- Slip fit dowel pin holes located in body and jaws



**Operating information**

Operating pressure:	3 to 7 bar (44 to 102 PSIG)
Temperature range:	
Nitrile seals (standard)	-35° to 80° C (-30° to 180° F)
Fluorocarbon seals (optional)	-30° to 120° C (-20° to 250° F)
Filtration requirements:	
Air filtration	40 micron or better
Air lubrication	Not necessary*
Air humidity	Low moisture content (dry)
*Addition of lubrication will greatly increase service life	

**Ordering Information: P5GV Miniature Clean Room Series**

Function	Bore size (mm)	Ports (BSPP)	Stroke (mm)	Grip force @ 7 bar (N)	Accuracy +/- mm	Repeatability +/-mm	Weight (kg)	Part number
Double acting, Nitrile	10	M3	3.2	36	0.05	0.03	0.024	<b>P5GV-010MSG003B</b>
Double acting, Fluorocarbon	10	M3	3.2	36	0.05	0.03	0.024	<b>P5GV-010MFG003B</b>
Double acting, Nitrile	10	M3	4.8	36	0.05	0.03	0.026	<b>P5GV-010MSG005B</b>
Double acting, Fluorocarbon	10	M3	4.8	36	0.05	0.03	0.026	<b>P5GV-010MFG005B</b>
Double acting, Nitrile	10	M3	6.3	36	0.05	0.03	0.034	<b>P5GV-010MSG006B</b>
Double acting, Fluorocarbon	10	M3	6.3	36	0.05	0.03	0.034	<b>P5GV-010MFG006B</b>

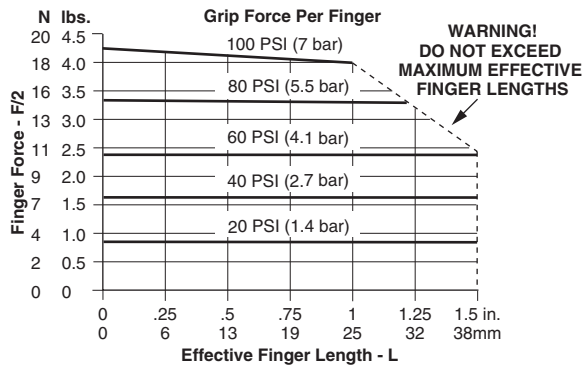
Not available with sensors.

<b>Automation Products</b>
<b>Grippers</b>
<b>Slide Tables</b>
<b>Rotary Tables</b>
<b>Escapements</b>
<b>Sensors &amp; Fittings</b>



For inventory, lead times, and kit lookup, visit [www.pdnplu.com](http://www.pdnplu.com)

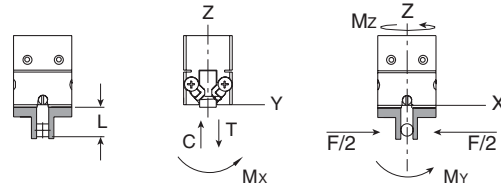
**Loading information - P5GV**



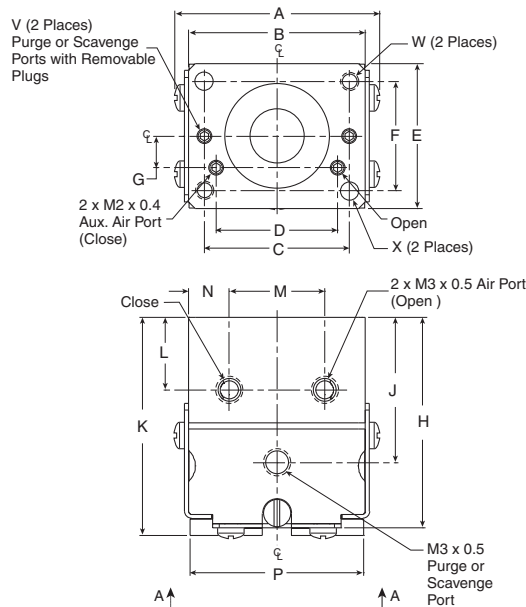
**Loading capacity† - P5GV**

	Static (metric)	Dynamic (metric)
Maximum tensile T	89 N	31 N
Maximum compressive C	89 N	31 N
Maximum moment Mx	1 Nm	0.5 Nm
Maximum moment My	2 Nm	0.6 Nm
Maximum moment Mz	1 Nm	0.5 Nm

† Capacities are per set of jaws and are not simultaneous

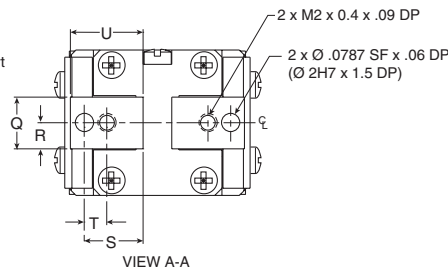


**Dimensions: P5GV Miniature Clean Room Series**



Unless otherwise noted all tolerances are as shown below

Dimensions are symmetrical about centerline  
 Third Angle Projection  
**Metric (mm)**  
 (0.) = (±.25)  
 (0.0) = (±.13)  
 (0.00) = (±.013)



Part number	A	B	C	D	E	F	G	H	J	K	L	M
<b>P5GV-010MS(F)G003B</b>	23	19.5	16.0	13.4	16.0	12.00	3.5	23	16	24.0	8	10.5
<b>P5GV-010MS(F)G005B</b>	24	21.0	16.0	13.4	16.0	12.00	3.5	25	17	25.5	9	10.5
<b>P5GV-010MS(F)G006B</b>	30	26.5	20.0	13.4	16.0	11.00	3.5	25	18	25.5	10	10.5

Part number	N	P	Q	R	S	T	U	V	W	X
<b>P5GV-010MS(F)G003B</b>	4.5	Open 19.2 Closed 16	.569 ±0.03	2.8	6.50	2.5	8	M2 x 0.4	M2 x .18 4.5 Dp	Ø 2H7 x 3.3 Dp
<b>P5GV-010MS(F)G005B</b>	5.2	Open 20.8 Closed 16	.569 ±0.03	2.8	6.50	2.5	8	M2 x 0.4	M2 x 0.4 .18 Dp	Ø 2H7 x 3.3 Dp
<b>P5GV-010MS(F)G006B</b>	8.0	Open 126.4 Closed 20	.569 ±0.03	2.8	7.50	2.5	10	M2 x 0.5	M3 x 0.5 .20 Dp	Ø 3H7 x 5.0 Dp

Dimensions in millimeters

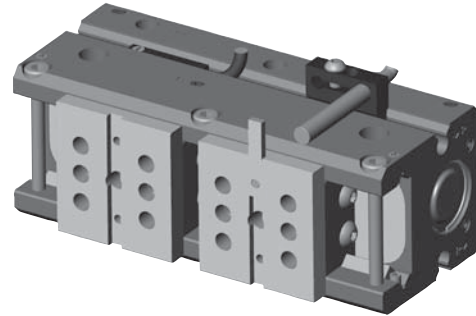


For inventory, lead time, and kit lookup, visit [www.pdnplu.com](http://www.pdnplu.com)

**Features**

**P5GR Parallel High Precision Series**

- Excellent parallelism and accuracy between gripper mounting surface and jaw surfaces
- H7 dowel pin holes in body and jaws. Jaws also have key slot for better finger alignment.
- Hardened plated jaws for wear resistance and longer life
- Top manifold air ports eliminates the need for airlines
- “Dual-V” roller bearings provide low friction motion and are preloaded for maximum support and zero side play
- One piece, aircraft quality aluminum body, has hard-coat anodized 60 RC with PTFE impregnation
- Standard purge / scavenge port used with vacuum for clean room environments or positive pressure for harsh environments and jaw surfaces
- Adjustable pre-load screws allows for adjustment of preload on roller bearings
- 4 standard air port locations; front, top and both sides
- Shielded design repels contamination from penetrating the “Dual-V” roller bearings
- Magnetic piston standard



**Operating information**

Pressure range (without springs):	0.3 to 7 bar (4 to 102 PSIG)
Pressure range (with springs):	
P5GR-010MSG006B & P5GR-010MSG013B	1.4 to 7 bar (20 to 102 PSIG)
P5GR-014MSG016B & P5GR-014MSG025B	3.4 to 7 bar (49 to 102 PSIG)
P5GR-021MSG025B	2.8 to 7 bar (41 to 102 PSIG)
P5GR-021MSG038B	2.1 to 7 bar (30 to 102 PSIG)
Temperature range:	
Nitrile seals (standard)	-35° to 80° C (-30° to 180° F)
Filtration requirements:	
Air filtration	40 micron or better
Air lubrication	Not necessary*
Air humidity	Low moisture content (dry)

\*Addition of lubrication will greatly increase service life

**Ordering Information: P5GR High Precision Series**

Function	Bore size (mm)	Ports (BSPP)	Stroke (mm)	Grip force @ 7 bar (N)	Accuracy +/- mm	Repeatability +/-mm	Weight (kg)	Part number
Double acting magnetic	10	M3	6.4	120	0.001	0.00005	0.16	<b>P5GR-010MSG006B</b>
Spring closing, magnetic	10	M3	6.4	120	0.001	0.00005	0.16	<b>P5GR-010DSG006B</b>
Double acting magnetic	10	M3	12.7	120	0.001	0.00005	0.20	<b>P5GR-010MSG013B</b>
Spring closing, magnetic	10	M3	12.7	120	0.001	0.00005	0.20	<b>P5GR-010DSG013B</b>
Double acting magnetic	14	M3	15.9	227	0.001	0.00005	0.48	<b>P5GR-014MSG016B</b>
Spring closing, magnetic	14	M3	15.9	227	0.001	0.00005	0.48	<b>P5GR-014DSG016B</b>
Double acting magnetic	14	M3	25.4	214	0.001	0.00005	0.57	<b>P5GR-014MSG025B</b>
Spring closing, magnetic	14	M3	25.4	214	0.001	0.00005	0.57	<b>P5GR-014DSG025B</b>
Double acting magnetic	21	M5	25.4	458	0.001	0.00005	1.02	<b>P5GR-021MSG025B</b>
Spring closing, magnetic	21	M5	25.4	458	0.001	0.00005	1.02	<b>P5GR-021DSG025B</b>
Double acting magnetic	21	M5	38.1	449	0.001	0.00005	1.41	<b>P5GR-021MSG038B</b>
Spring closing, magnetic	21	M5	38.1	449	0.001	0.00005	1.41	<b>P5GR-021DSG038B</b>

Sensor part numbers: Page F52.

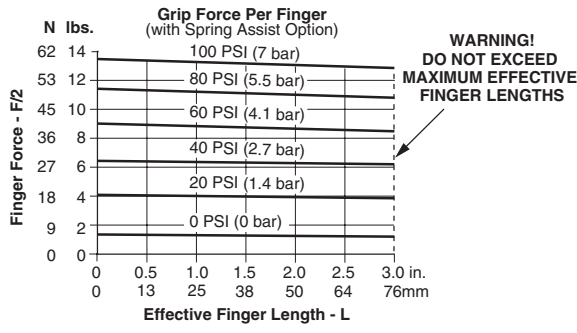
**Automation Products**  
**Grippers**  
**Slide Tables**  
**Rotary Tables**  
**Escapements**  
**Sensors & Fittings**



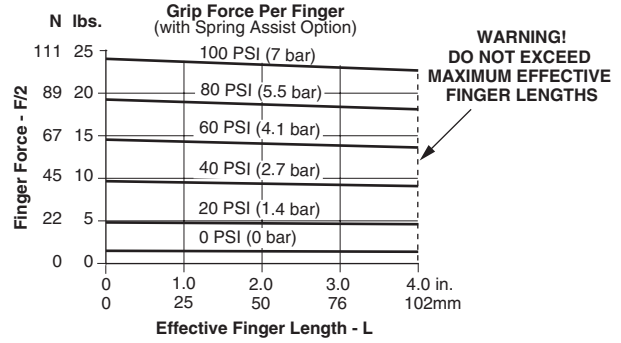
For inventory, lead times, and kit lookup, visit [www.pdnplu.com](http://www.pdnplu.com)



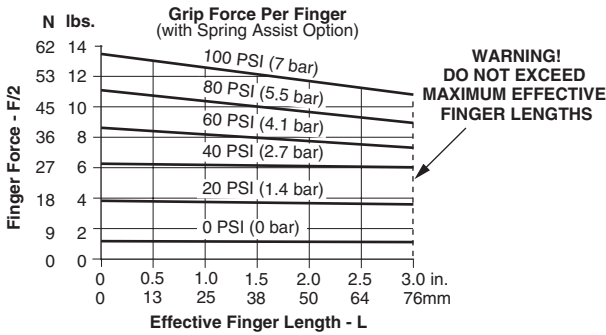
**Loading information - P5GR-010\*\*\*006**



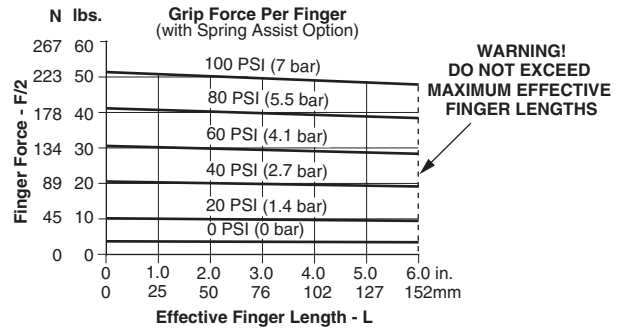
**Loading information - P5GR-014\*\*\*025**



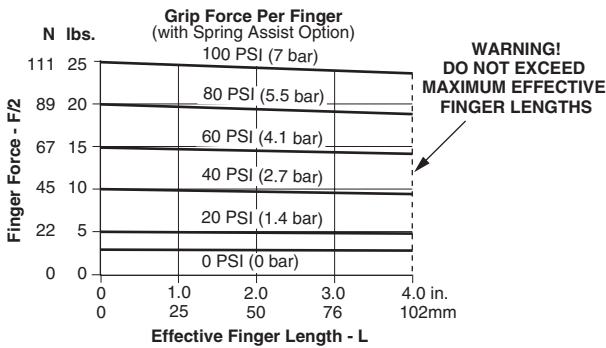
**Loading information - P5GR-010\*\*\*013**



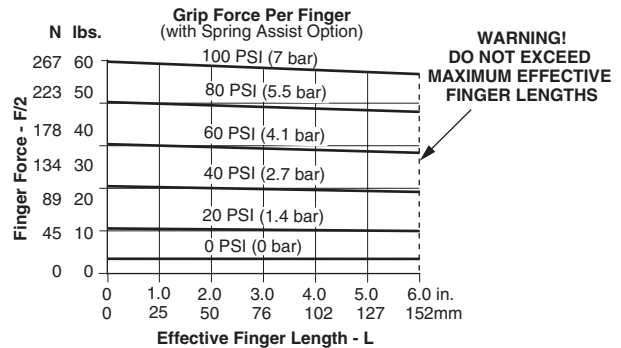
**Loading information - P5GR-021\*\*\*025**



**Loading information - P5GR-014...016**



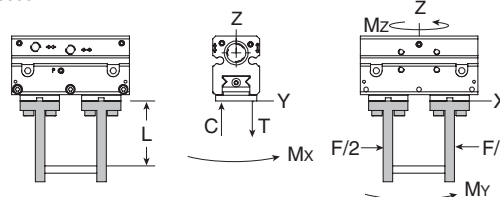
**Loading information - P5GR-021\*\*\*038**



**Loading capacity† - P5GR High Precision Series**

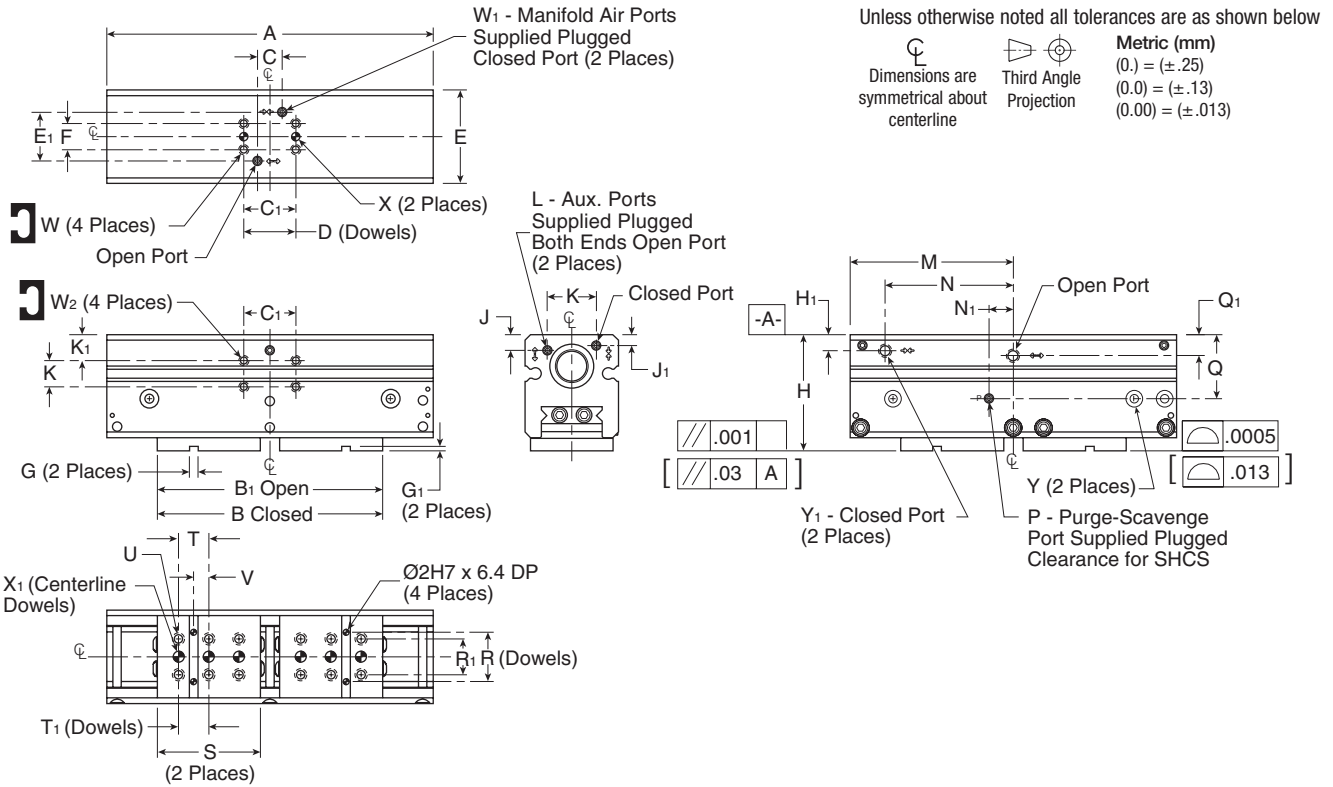
	P5GR-010***006		P5GR-010***013		P5GR-014***016		P5GR-014***025		P5GR-021***025		P5GR-021***038	
	Static (metric)	Dynamic (metric)	Static (metric)	Dynamic (metric)	Static (metric)	Dynamic (metric)	Static (metric)	Dynamic (metric)	Static (metric)	Dynamic (metric)	Static (metric)	Dynamic (metric)
Maximum tensile <b>T</b>	267 N	89 N	311 N	102 N	556 N	187 N	734 N	245 N	667 N	222 N	890 N	245 N
Maximum compressive <b>C</b>	267 N	89 N	311 N	102 N	556 N	187 N	734 N	245 N	667 N	222 N	890 N	245 N
Maximum moment <b>Mx</b>	4.0 Nm	1.4 Nm	5.6 Nm	1.9 Nm	9.0 Nm	3.1 Nm	11 Nm	3.7 Nm	34 Nm	11 Nm	45 Nm	15 Nm
Maximum moment <b>My</b>	5.6 Nm	1.9 Nm	7.3 Nm	4.0 Nm	12 Nm	4.0 Nm	14 Nm	4.7 Nm	40 Nm	4.7 Nm	51 Nm	17 Nm
Maximum moment <b>Mz</b>	4.0 Nm	1.4 Nm	5.6 Nm	1.9 Nm	9.0 Nm	3.1 Nm	11 Nm	3.7 Nm	34 Nm	11 Nm	45 Nm	15 Nm

† Capacities are per set of jaws and are not simultaneous



For inventory, lead time, and kit lookup, visit [www.pdnplu.com](http://www.pdnplu.com)

**Dimensions: P5GR High Precision Series**



Part number	A	B	B1	C	C1	D	E	E1	F	G	G1	H	H1	J	J1	K	K1	L	M	N	N1	P
P5GR-010***006	62.9	47	53	8.9	19.1	19.05	25.0	15.2	9.5	3.15 <sup>+0.02</sup>	1.52 <sup>+0.02</sup>	34.67 <sup>+0.02</sup>	5.8	4.4	3.8	9.5	8.5	M3 x 3 Dp	31.4	18.7	5.1	M3 x 3 Dp
P5GR-010***013	73.7	49	62	8.9	19.1	19.05	25.0	15.2	9.5	3.15 <sup>+0.02</sup>	1.52 <sup>+0.02</sup>	34.67 <sup>+0.02</sup>	5.8	4.4	3.8	9.5	8.5	M3 x 3 Dp	36.8	24.1	5.1	M3 x 3 Dp
P5GR-014***016	90.2	63	79	8.9	19.1	19.05	34.0	17.8	9.5	3.15 <sup>+0.02</sup>	1.52 <sup>+0.02</sup>	42.21 <sup>+0.02</sup>	5.8	5.7	3.9	9.5	9.5	M3 x 3 Dp	45.1	32.4	8.9	M3 x 3 Dp
P5GR-014***025	118.7	82	107	8.9	19.1	19.05	34.0	17.8	9.5	3.15 <sup>+0.02</sup>	1.52 <sup>+0.02</sup>	42.21 <sup>+0.02</sup>	5.8	5.7	3.9	9.5	9.5	M3 x 3 Dp	59.4	46.7	8.9	M3 x 3 Dp
P5GR-021***025	129	89	115	12.7	38.1	38.10	46.0	28.7	19.1	3.15 <sup>+0.02</sup>	1.52 <sup>+0.02</sup>	55.63 <sup>+0.02</sup>	5.8	7.0	5.8	19.1	9.5	M5 x 5 Dp	64.5	45.5	14.0	M5 x 5 Dp
P5GR-021***038	175.5	123	161	12.7	38.1	38.10	46.0	28.7	19.1	3.15 <sup>+0.02</sup>	1.52 <sup>+0.02</sup>	55.63 <sup>+0.02</sup>	5.8	7.0	5.8	19.1	9.5	M5 x 5 Dp	87.8	68.7	14.0	M5 x 5 Dp

Part number	Q	Q1	R	R1	S	T	T1	U	V	W	W1	W2	X	X1	Y	Y1
P5GR-010***006	18.5	7.4	9.19	9.0	21	12	11.99	M3 x 5 Dp	6.0	M3 x 4 Dp	M3 x 3 Dp	M3 x 4 Dp	Ø3H7 x 2.5 Dp	Ø2H7 x 3.6 Dp	Ø6.35 x 3 Dp	M5 x 4 Dp
P5GR-010***013	18.5	7.4	9.20	9.0	21	12	11.99	M3 x 5 Dp	6.0	M3 x 4 Dp	M3 x 3 Dp	M3 x 4 Dp	Ø3H7 x 2.5 Dp	Ø2H7 x 3.6 Dp	Ø6.35 x 3 Dp	M5 x 4 Dp
P5GR-014***016	23.2	8.0	17.98	13.0	28	16	16.00	M4 x 7 Dp	8.0	M3 x 4 Dp	M3 x 3 Dp	M3 x 5 Dp	Ø3H7 x 2.5 Dp	Ø4H7 x 3.6 Dp	Ø6.35 x 3 Dp	M5 x 5 Dp
P5GR-014***025	23.2	8.0	17.98	13.0	37.5	11	11.00	M4 x 7 Dp	5.5	M3 x 4 Dp	M3 x 3 Dp	M3 x 5 Dp	Ø3H7 x 2.5 Dp	Ø4H7 x 3.6 Dp	Ø6.35 x 3 Dp	M5 x 5 Dp
P5GR-021***025	31.1	11.2	25.78	17.0	40.0	12.5	12.50	M5 x 10 Dp	6.2	M5 x 5 Dp	M5 x 5 Dp	M5 x 5 Dp	Ø5H7 x 3.0 Dp	Ø5H7 x 5.3 Dp	Ø6.35 x 3 Dp	M5 x 5 Dp
P5GR-021***038	31.1	11.2	25.78	17.0	58.0	16.0	16.00	M5 x 10 Dp	8.0	M5 x 5 Dp	M5 x 5 Dp	M5 x 5 Dp	Ø5H7 x 3.0 Dp	Ø5H x 5.3 Dp	Ø6.35 x 3 Dp	M5 x 5 Dp

Dimensions in millimeters

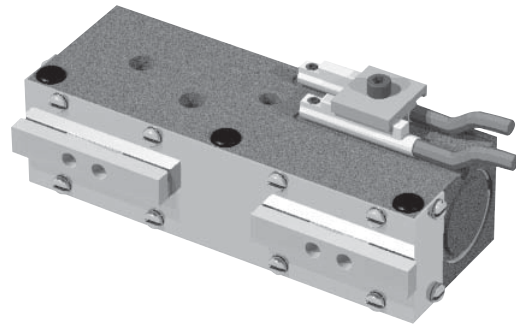
Automation Products  
 Grippers  
 Slide Tables  
 Rotary Tables  
 Escapements  
 Sensors & Fittings



For inventory, lead times, and kit lookup, visit [www.pdnplu.com](http://www.pdnplu.com)

**P5GU Parallel Clean Room Harsh Environment Series**

- Internal components are made from hardened bearing and tool steels. External components are made from corrosion resistant materials for resistance to de-ionized water or for use in FDA and medical parts handling applications.
- Stationary and non-contacting stainless steel shields eliminate the possibility of particle generation
- Adjustable preload screws allow for adjustment of preload on roller bearings
- The body has hard-coat anodized 60 RC with PTFE impregnation
- Dual “V” roller bearings provide low friction rolling motion. Roller bearings are preloaded for maximum support and zero side play.
- Units are lubricated with a clean room grade grease
- Slip fit dowel pin holes in body
- Purge / scavenge port for extreme environments from dirty and gritty to clean room Class 10 or better
- Stainless steel screws provide protection against corrosion
- Magnetic piston standard



**Operating information**

Operating pressure:	0.3 to 7 bar (4 to 102 PSIG)
Temperature range:	
Standard seals	-35° to 80° C (-30° to 180° F)
Fluorocarbon seals	-30° to 120° C (-20° to 248° F)
Filtration requirements:	
Air filtration	40 micron or better
Air lubrication	Not necessary*
Air humidity	Low moisture content (dry)

\*Addition of lubrication will greatly increase service life

**Ordering Information: Clean Room Harsh Environment Series**

Function	Bore size (mm)	Ports (BSP)	Stroke (mm)	Grip force @ 7 bar (N)	Accuracy +/- mm	Repeatability +/-mm	Weight (kg)	Part number
Double acting magnetic	11	M5	6.4	116	0.05	0.03	0.07	<b>P5GU-011MSG006B</b>
Double acting magnetic	11	M5	6.4	116	0.05	0.03	0.07	<b>P5GU-011MFG006B</b>
Double acting magnetic	11	M5	12.7	116	0.05	0.03	0.09	<b>P5GU-011MSG013B</b>
Double acting magnetic	11	M5	12.7	116	0.05	0.03	0.09	<b>P5GU-011MFG013B</b>
Double acting magnetic	13	M5	19.1	160	0.05	0.03	0.15	<b>P5GU-013MSG019B</b>
Double acting magnetic	13	M5	19.1	160	0.05	0.03	0.15	<b>P5GU-013MFG019B</b>
Double acting magnetic	13	M5	25.4	160	0.05	0.03	0.17	<b>P5GU-013MSG025B</b>
Double acting magnetic	13	M5	25.4	160	0.05	0.03	0.17	<b>P5GU-013MFG025B</b>

Sensor part numbers: Page F52.

D<sup>1</sup> With linear ball bearing

D<sup>2</sup> With composite bushing

\*\* For Model 100 with 25mm stroke, A = 100.3 (3.95") and E = 28 (1.10")



Automation Products

Grippers

Slide Tables

Rotary Tables

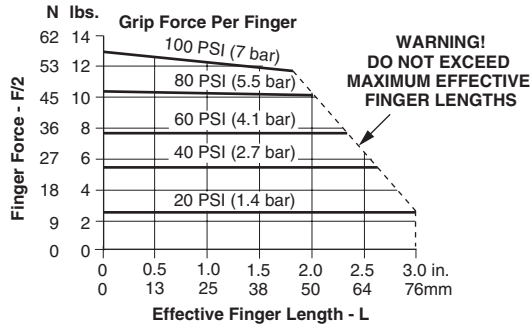
Escapements

Sensors & Fittings

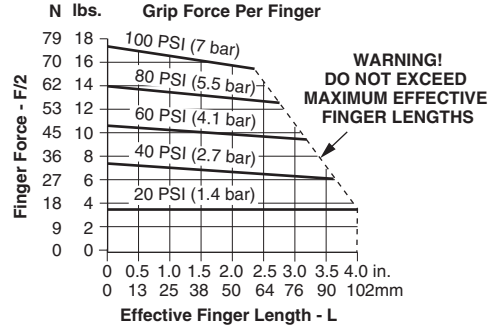


For inventory, lead time, and kit lookup, visit [www.pdnplu.com](http://www.pdnplu.com)

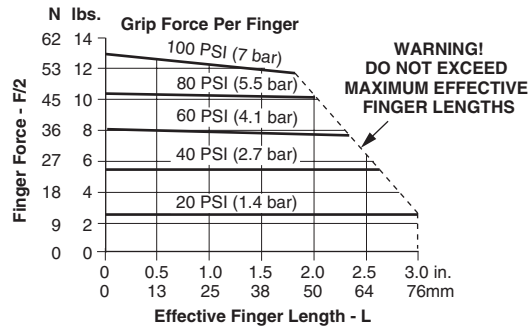
**Loading information - P5GU-011\*\*\*006**



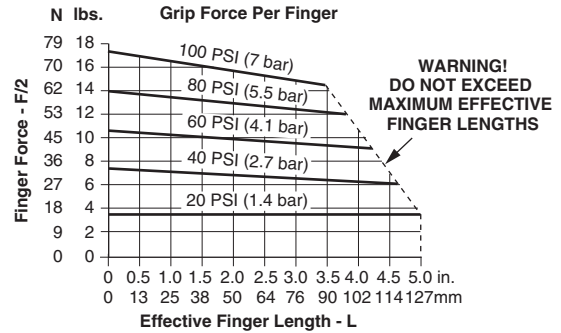
**Loading information - P5GU-013\*\*\*019**



**Loading information - P5GU-011\*\*\*013**



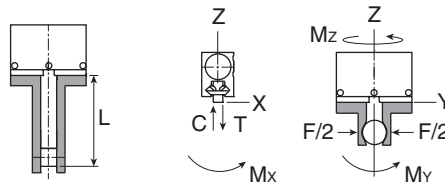
**Loading information - P5GU-013\*\*\*025**



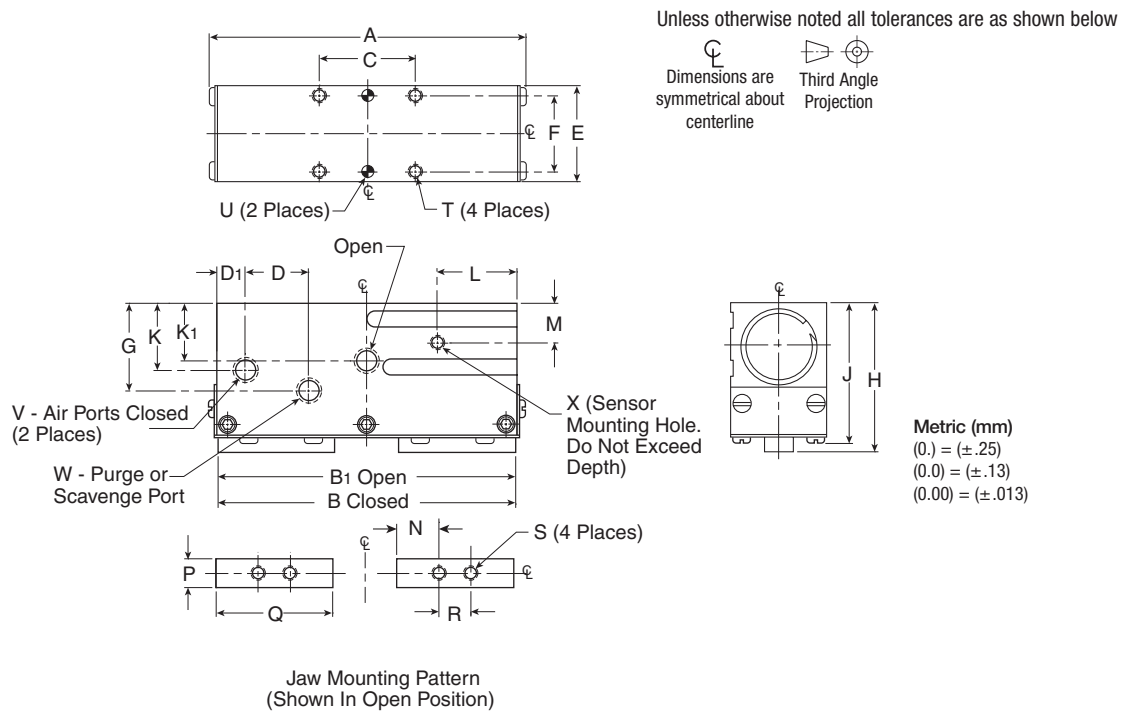
**Loading capacity† - P5GU Clean Room Harsh Environment Series**

	P5G-011***006		P5GU-011***013		P5GU-013***019		P5GU-013***025	
	Static (metric)	Dynamic (metric)	Static (metric)	Dynamic (metric)	Static (metric)	Dynamic (metric)	Static (metric)	Dynamic (metric)
Maximum tensile T	222 N	67 N	289 N	89 N	400 N	133 N	534 N	178 N
Maximum compressive C	222 N	67 N	289 N	89 N	400 N	133 N	534 N	178 N
Maximum moment Mx	3.4 Nm	1.1 Nm	5.1 Nm	1.7 Nm	6.8 Nm	2.3 Nm	8.5 Nm	2.8 Nm
Maximum moment My	4.5 Nm	1.4 Nm	6.8 Nm	2.3 Nm	9.0 Nm	2.8 Nm	11.3 Nm	4.0 Nm
Maximum moment Mz	3.4 Nm	1.1 Nm	5.1 Nm	1.7 Nm	6.8 Nm	2.3 Nm	8.5 Nm	2.8 Nm

† Capacities are per set of jaws and are not simultaneous



**Dimensions: P5GU Clean Room Harsh Environment Series**



Part number	A	B	B <sub>1</sub>	C	D	D <sub>1</sub>	E	F	G	H	J	K	K <sub>1</sub>	L	M	N	P	Q	R
<b>P5GU-011(006)</b>	48.3	38	44	19.1	8	6	19.1	15.09	17	29.5	27.8	13	11	11	8	6.4	5.69 <sup>+0.003</sup> <sub>-.003</sub>	19.1	6.4
<b>P5GU-011(013)</b>	62.9	46	59	19.1	13	6	19.0	15.09	17	29.5	27.8	13	11	16	8	8.3	5.69 <sup>+0.003</sup> <sub>-.003</sub>	23.2	6.4
<b>P5GU-013(019)</b>	83.4	63	83	25.4	14	15	22.2	16.66	18	32.6	30.3	13	11	19	8	12.7	5.69 <sup>+0.003</sup> <sub>-.003</sub>	31.8	6.4
<b>P5GU-013(025)</b>	101.8	76	101	25.4	14	24	22.2	16.66	18	32.6	30.3	13	11	25	8	15.9	5.69 <sup>+0.003</sup> <sub>-.003</sub>	38.1	6.4

Part number	S	T	U	V	W	X
<b>P5GU-011(006)</b>	M3 x 4 Dp	M3 x 4 Dp	∅ 3 SF x 4 Dp	M5	M5	M3 x 3 Dp
<b>P5GU-011(013)</b>	M3 x 4 Dp	M3 x 4 Dp	∅ 3 SF x 4 Dp	M5	M5	M3 x 4 Dp
<b>P5GU-013(019)</b>	M3 x 4 Dp	M3 x 8 Dp	∅ 3 SF x 6 Dp	M5	M5	M3 x 4 Dp
<b>P5GU-013(025)</b>	M3 x 4 Dp	M3 x 8 Dp	∅ 3 SF x 6 Dp	M5	M5	M3 x 4 Dp

Dimensions in millimeters

**F**

Automation  
Products

Grippers

Slide  
Tables

Rotary  
Tables

Escapements

Sensors &  
Fittings

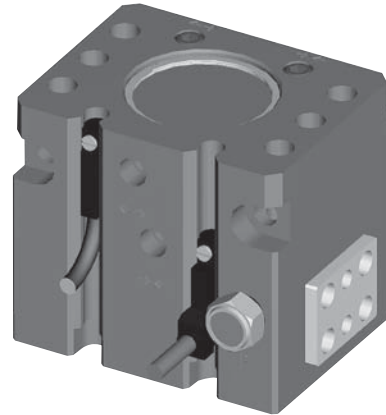


For inventory, lead time, and kit lookup, visit [www.pdnplu.com](http://www.pdnplu.com)

**Features**

**P5GN Series, Compact**

- One piece lightweight aircraft quality aluminum body
- The body and bottom plate have hard-coat anodize 60 RC with PTFE impregnation
- 3 standard air port locations (front, back, and top)
- Back and top air ports can be o-ring manifold sealed to eliminate air lines
- Standard mounting slots for magneto resistive (sensors sold separately)
- Slip fit dowel pin holes in body and jaws
- Jaws are supported throughout the length of the body
- Purge / scavenge port used with vacuum for clean room environments or positive pressure with harsh environments
- Jaw components made from hardened and precision ground steel for minimum jaw play with hard plating for wear resistance and long life
- Front-to-back thru counterbores for socket head cap screw mounting
- Magnetic piston standard



**Operating information**

Operating pressure:	1.5 to 7 bar (22 to 102 PSIG)
Temperature range:	
Nitrile seals (standard)	-35° to 80° C (-30° to 180° F)
Filtration requirements:	
Air filtration	40 micron or better
Air lubrication	Not necessary*
Air humidity	Low moisture content (dry)

\*Addition of lubrication will greatly increase service life

**Ordering Information: P5GN Compact Series**

Function	Bore size (mm)	Ports (BSPP)	Stroke (mm)	Grip force @ 7 bar (N)	Accuracy +/- mm	Repeatability +/-mm	Weight (kg)	Part number
Double acting magnetic	12	M3	1.6	62	0.05	0.03	0.04	<b>P5GN-012MSG001B</b>
Double acting magnetic	12	M3	2.4	62	0.05	0.03	0.04	<b>P5GN-012MSG002B</b>
Double acting magnetic	12	M3	3.2	62	0.05	0.03	0.04	<b>P5GN-012MSG003B</b>
Double acting magnetic	14	M3	2.4	98	0.05	0.03	0.07	<b>P5GN-014MSG002B</b>
Double acting magnetic	14	M3	3.2	98	0.05	0.03	0.07	<b>P5GN-014MSG003B</b>
Double acting magnetic	14	M3	4.8	98	0.05	0.03	0.07	<b>P5GN-014MSG005B</b>
Double acting magnetic	22	M5	3.2	222	0.05	0.03	0.23	<b>P5GN-022MSG003B</b>
Double acting magnetic	22	M5	4.8	222	0.05	0.03	0.23	<b>P5GN-022MSG005B</b>
Double acting magnetic	22	M5	6.4	222	0.05	0.03	0.23	<b>P5GN-022MSG006B</b>
Double acting magnetic	32	M5	4.8	445	0.08	0.03	0.46	<b>P5GN-032MSG005B</b>
Double acting magnetic	32	M5	6.4	445	0.08	0.03	0.46	<b>P5GN-032MSG006B</b>
Double acting magnetic	32	M5	9.5	445	0.08	0.03	0.46	<b>P5GN-032MSG010B</b>

Sensor part numbers: Page F52.

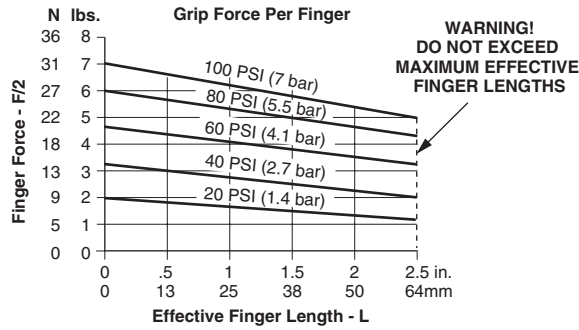
Most popular.

**Automation Products**  
**Grippers**  
**Slide Tables**  
**Rotary Tables**  
**Escapements**  
**Sensors & Fittings**

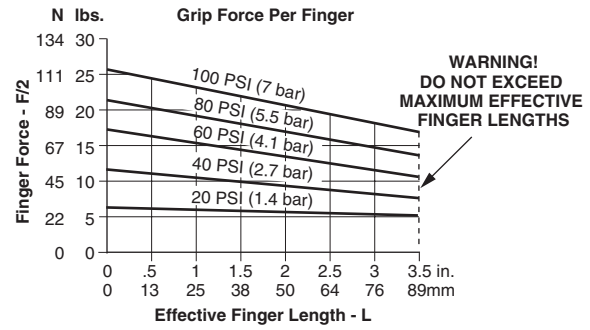


For inventory, lead times, and kit lookup, visit [www.pdnplu.com](http://www.pdnplu.com)

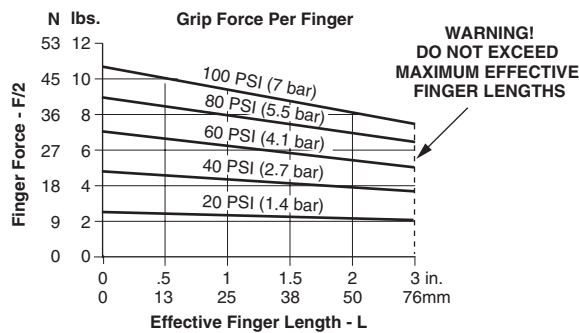
**Loading information - P5GN-012**



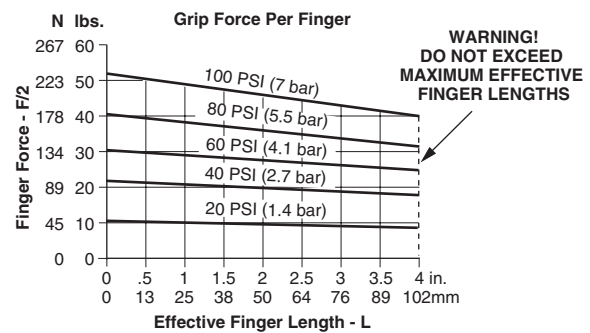
**Loading information - P5GN-022**



**Loading information - P5GN-014**



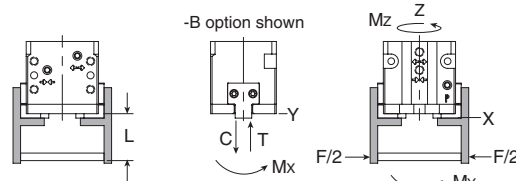
**Loading information - P5GN-032**



**Loading capacity† - P5GN Compact Series**

	P5GN-012		P5GN-014		P5GN-022		P5GN-032	
	Static (metric)	Dynamic (metric)	Static (metric)	Dynamic (metric)	Static (metric)	Dynamic (metric)	Static (metric)	Dynamic (metric)
Maximum tensile T	134 N	27 N	267 N	45 N	614 N	111 N	2225 N	289 N
Maximum compressive C	223 N	45 N	401 N	67 N	1224 N	111 N	4228 N	289 N
Maximum moment Mx	2 Nm	0.6 Nm	5 Nm	8 Nm	14 Nm	2 Nm	48 Nm	8 Nm
Maximum moment My	2 Nm	0.6 Nm	5 Nm	8 Nm	14 Nm	2 Nm	48 Nm	8 Nm
Maximum moment Mz	2 Nm	0.6 Nm	5 Nm	8 Nm	14 Nm	2 Nm	48 Nm	8 Nm

† Capacities are per set of jaws and are not simultaneous



**F**

Automation Products

Grippers

Slide Tables

Rotary Tables

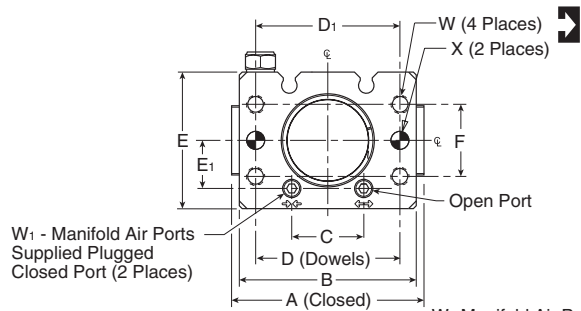
Escapements

Sensors & Fittings



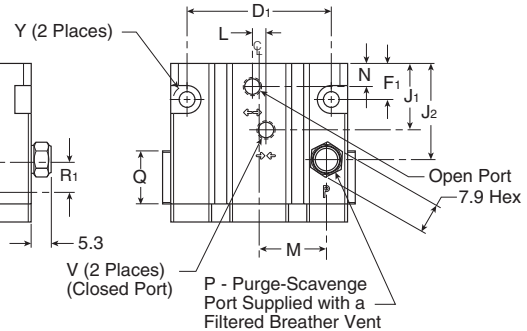
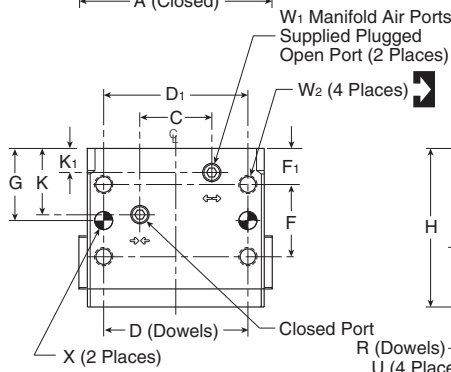
For inventory, lead time, and kit lookup, visit [www.pdnplu.com](http://www.pdnplu.com)

**Dimensions: P5GN Compact Series**



Unless otherwise noted all tolerances are as shown below

Dimensions are symmetrical about centerline  
 Third Angle Projection  
**Metric (mm)**  
 (0.) = (± .25)  
 (0.0) = (± .13)  
 (0.00) = (± .013)



Part number	A	B	C	D	D1	E	E1	F	F1	G	H	J	J1	J2	K	K1	L	M	N	P
<b>P5GN-012</b>	28	24.4	10.2	19.05	19.1	22.2	7.9	9.5	6.7	11.4	24.4	17.6	9.7	14.7	9.7	3.6	-	9.4	3.6	M3 x 3 Dp
<b>P5GN-014</b>	35	31.2	10.2	19.05	19.1	24.1	8.6	9.5	8.0	12.7	27.4	19.9	11.2	17.0	11.2	3.6	-	11.7	3.6	M3 x 3 Dp
<b>P5GN-022</b>	51	46.7	19.1	38.10	38.1	36.1	12.7	19.1	9.5	19.1	41.9	26.1	17.5	25.4	17.5	6.1	3.6	17.8	6.1	M5 x 4 Dp
<b>P5GN-032</b>	64	59.7	22.9	38.10	38.1	43.2	16.5	19.1	12.7	22.2	51.2	31.3	19.8	30.5	19.8	6.4	4.1	22.4	6.4	M5 x 4 Dp

Part number	Q	R	R1	S	T	U	V	W	W1	W2	X	Y	Z
<b>P5GN-012</b>	7.11 <sup>+0.003</sup> / <sub>-0.003</sub>	3.81	-	10.67 <sup>+0.003</sup> / <sub>-0.003</sub>	6.4	∅ 2.0 H7 x 3 Dp	M3 x 3 Dp	M3 x 4 Dp	M3 x 3 Dp	M3 x 4 Dp	∅ 3 H7 x 3 Dp	∅ 5 x 4 Dp C'bore (for M2.5 SHCS)	M3 x 4 Dp (4 Places)
<b>P5GN-014</b>	8.64 <sup>+0.003</sup> / <sub>-0.003</sub>	4.76	-	12.19 <sup>+0.003</sup> / <sub>-0.003</sub>	7.1	∅ 2.5 H7 x 3 Dp	M3 x 3 Dp	M3 x 4 Dp	M3 x 3 Dp	M3 x 4 Dp	∅ 3 H7 x 3 Dp	∅ 5 x 3 Dp C'bore (for M2.5 SHCS)	M4 x 5 Dp (4 Places)
<b>P5GN-022</b>	13.97 <sup>+0.003</sup> / <sub>-0.003</sub>	7.94	8.0	18.29 <sup>+0.003</sup> / <sub>-0.003</sub>	11.4	∅ 3 H7 x 5 Dp	M5 x 4 Dp	M5 x 8 Dp	M5 x 5 Dp	M5 x 6 Dp	∅ 5 H7 x 5 Dp	∅ 7 x 4 Dp C'bore (for M4 SHCS)	M4 x 6 Dp (8 Places)
<b>P5GN-032</b>	19.05 <sup>+0.003</sup> / <sub>-0.003</sub>	11.11	11.1	25.40 <sup>+0.003</sup> / <sub>-0.003</sub>	15.9	∅ 4 H7 x 6 Dp	M5 x 4 Dp	M5 x 8 Dp	M5 x 5 Dp	M5 x 6 Dp	∅ 5 H7 x 6 Dp	∅ 7 x 4 Dp C'bore (for M4 SHCS)	M5 x 8 Dp (8 Places)

Dimensions in millimeters

Automation Products  
 Grippers  
 Slide Tables  
 Rotary Tables  
 Escapements  
 Sensors & Fittings



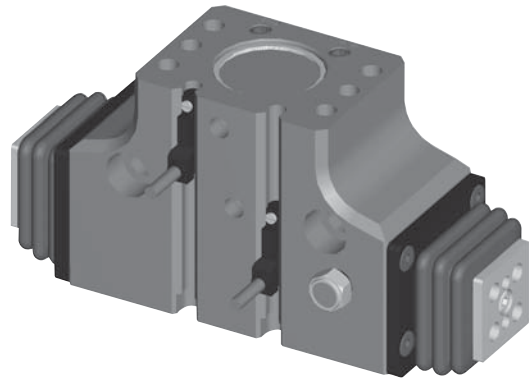
For inventory, lead times, and kit lookup, visit [www.pdnplu.com](http://www.pdnplu.com)



**Features**

**P5GM Parallel Series**

- One piece lightweight aircraft quality aluminum body
- The body and bottom plate have hard-coat anodize 60 RC with PTFE impregnation
- 3 standard air port locations (front, back, and top)
- Back and top air ports can be o-ring manifold sealed to eliminate air lines
- Standard mounting slots for magneto resistive (sensors sold separately)
- Slip fit dowel pin holes in body and jaws
- Jaws are supported throughout the length of the body
- Purge / scavenge port used with vacuum for clean room environments or positive pressure with harsh environments
- Jaw components made from hardened and precision ground steel for minimum jaw play with hard plating for wear resistance and long life
- Front-to-back thru counterbores for socket head cap screw mounting
- Magnetic piston standard



Bellows are not included with the standard part numbers shown below. If bellows are required, please contact our Applications team for more information.

**Operating information**

Operating pressure:	1.5 to 7 bar (22 to 102 PSIG)
Temperature range:	
Nitrile seals (standard)	-35° to 80° C (-30° to 180° F)
Filtration requirements:	
Air filtration	40 micron or better
Air lubrication	Not necessary*
Air humidity	Low moisture content (dry)

\*Addition of lubrication will greatly increase service life

**Ordering Information: P5GM Parallel Series**

Function	Bore size (mm)	Ports (BSPP)	Stroke (mm)	Grip force @ 7 bar (N)	Accuracy +/- mm	Repeatability +/-mm	Weight (kg)	Part number
Double acting magnetic	10	M3	4.8	62	0.05	0.03	0.04	<b>P5GM-010MSG005B</b>
Double acting magnetic	10	M3	6.4	62	0.05	0.03	0.04	<b>P5GM-010MSG006B</b>
Double acting magnetic	10	M3	9.5	62	0.05	0.03	0.04	<b>P5GM-010MSG010B</b>
Double acting magnetic	14	M3	6.4	98	0.05	0.03	0.14	<b>P5GM-014MSG006B</b>
Double acting magnetic	14	M3	9.5	98	0.05	0.03	0.14	<b>P5GM-014MSG010B</b>
Double acting magnetic	14	M3	12.7	98	0.05	0.03	0.14	<b>P5GM-014MSG013B</b>
Double acting magnetic	22	M5	9.5	222	0.05	0.03	0.43	<b>P5GM-022MSG010B</b>
Double acting magnetic	22	M5	12.7	222	0.05	0.03	0.43	<b>P5GM-022MSG013B</b>
Double acting magnetic	22	M5	19.1	222	0.05	0.03	0.43	<b>P5GM-022MSG019B</b>
Double acting magnetic	32	M5	12.7	445	0.08	0.03	0.90	<b>P5GM-032MSG013B</b>
Double acting magnetic	32	M5	19.1	445	0.08	0.03	0.90	<b>P5GM-032MSG019B</b>
Double acting magnetic	32	M5	25.4	445	0.08	0.03	0.90	<b>P5GM-032MSG032B</b>

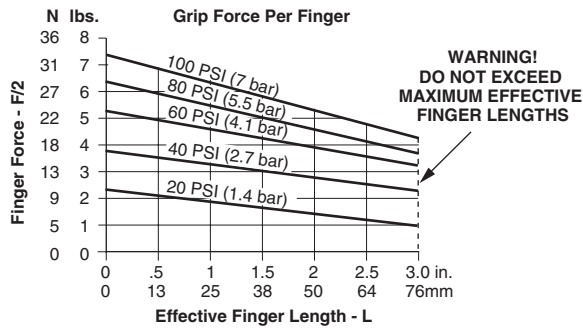
Sensor part numbers: Page F52.

**F**  
 Automation Products  
 Grippers  
 Slide Tables  
 Rotary Tables  
 Escapements  
 Sensors & Fittings

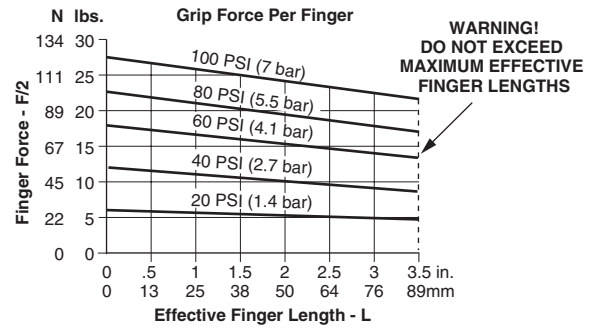


For inventory, lead time, and kit lookup, visit [www.pdnplu.com](http://www.pdnplu.com)

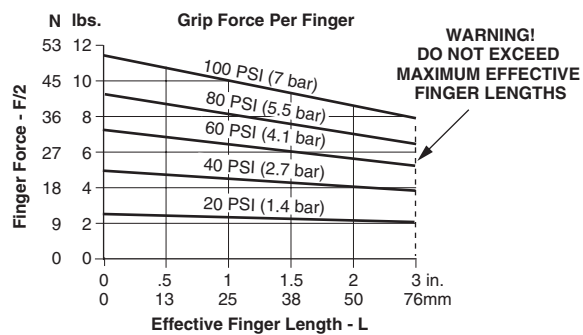
**Loading information - P5GM-010**



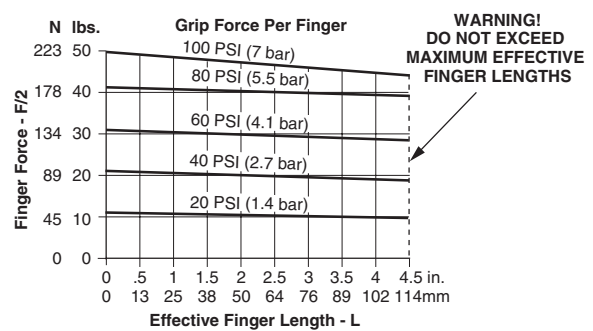
**Loading information - P5GM-022**



**Loading information - P5GM-014**



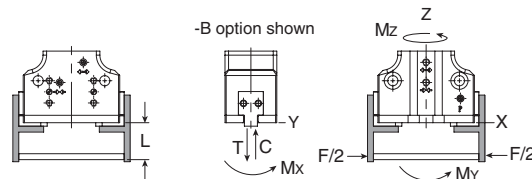
**Loading information - P5GM-032**



**Loading capacity† - P5GM Parallel Series**

	P5GM-010		P5GM-014		P5GM-022		P5GM-032	
	Static (metric)	Dynamic (metric)	Static (metric)	Dynamic (metric)	Static (metric)	Dynamic (metric)	Static (metric)	Dynamic (metric)
Maximum tensile T	445 N	67 N	556 N	111 N	1558 N	178 N	3004 N	401 N
Maximum compressive C	668 N	111 N	1113 N	111 N	2893 N	178 N	5785 N	401 N
Maximum moment Mx	10 Nm	2 Nm	13 Nm	2 Nm	28 Nm	5 Nm	73 Nm	12 Nm
Maximum moment My	10 Nm	2 Nm	13 Nm	2 Nm	28 Nm	5 Nm	73 Nm	12 Nm
Maximum moment Mz	10 Nm	2 Nm	13 Nm	2 Nm	28 Nm	5 Nm	73 Nm	12 Nm

† Capacities are per set of jaws and are not simultaneous

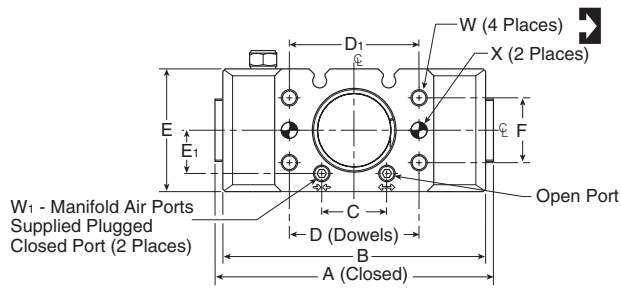


**Automation Products**  
**Grippers**  
**Slide Tables**  
**Rotary Tables**  
**Escapements**  
**Sensors & Fittings**



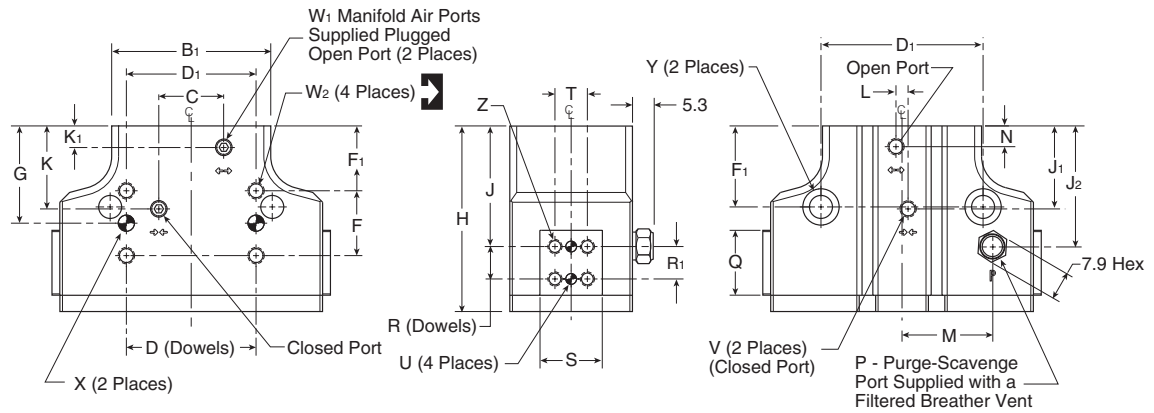
For inventory, lead times, and kit lookup, visit [www.pdnplu.com](http://www.pdnplu.com)

**Dimensions: P5GM Parallel Series**



Unless otherwise noted all tolerances are as shown below

Dimensions are symmetrical about centerline  
 Third Angle Projection  
**Metric (mm)**  
 (0.) = (±.25)  
 (0.0) = (±.13)  
 (0.00) = (±.013)



Part number	A	B	B <sub>1</sub>	C	D	D <sub>1</sub>	E	E <sub>1</sub>	F	F <sub>1</sub>	G	H	J	J <sub>1</sub>	J <sub>2</sub>	K	K <sub>1</sub>	L	M	N	P
<b>P5GM-010</b>	45	41.4	24.4	10.2	19.05	19.1	22.2	7.9	9.5	12.7	17.5	30.7	22.4	13.5	20.3	13.5	3.6	-	14.7	3.6	M3 x 3 Dp
<b>P5GM-014</b>	56	52.6	31.2	10.2	19.05	19.1	24.1	8.6	9.5	15.8	20.6	36.2	26.6	15.7	23.4	15.7	3.6	-	17.3	3.6	M3 x 3 Dp
<b>P5GM-022</b>	82	77.2	46.7	19.1	38.10	38.1	36.1	12.7	19.1	19.1	28.6	54.5	35.4	24.4	35.6	24.4	6.1	3.6	26.7	6.1	M5 x 4 Dp
<b>P5GM-032</b>	103	98.8	59.7	22.9	38.10	38.1	43.2	16.5	19.1	28.6	38.1	67.0	41.6	29.2	43.2	29.2	6.4	4.1	35.1	6.4	M5 x 4 Dp

Part number	Q	R	R <sub>1</sub>	S	T	U	V	W	W <sub>1</sub>	W <sub>2</sub>	X	Y	Z
<b>P5GM-010</b>	10.67 <sup>+0.003</sup> <sub>-0.003</sub>	4.76	-	10.67 <sup>+0.003</sup> <sub>-0.003</sub>	6.4	∅ 2.0 H7 x 3 Dp	M3 x 3 Dp	M3 x 4 Dp	M3 x 3 Dp	M3 x 4 Dp	∅ 3 H7 x 3 Dp	∅ 7 x 4 Dp C'bore (for M4 SHCS)	M3 x 4 Dp (4 Places)
<b>P5GM-014</b>	12.70 <sup>+0.003</sup> <sub>-0.003</sub>	4.76	-	12.19 <sup>+0.003</sup> <sub>-0.003</sub>	7.1	∅ 2.5 H7 x 3 Dp	M3 x 3 Dp	M3 x 4 Dp	M3 x 3 Dp	M3 x 4 Dp	∅ 3 H7 x 3 Dp	∅ 7 x 4 Dp C'bore (for M4 SHCS)	M4 x 5 Dp (4 Places)
<b>P5GM-022</b>	19.05 <sup>+0.003</sup> <sub>-0.003</sub>	9.53	9.5	18.29 <sup>+0.003</sup> <sub>-0.003</sub>	9.5	∅ 3 H7 x 5 Dp	M5 x 3Dp	M5 x 8 Dp	M5 x 5 Dp	M5 x 6 Dp	∅ 5 H7 x 5 Dp	∅ 11 x 7 Dp C'bore (for M6 SHCS)	M4 x 6 Dp (8 Places)
<b>P5GM-032</b>	25.40 <sup>+0.003</sup> <sub>-0.003</sub>	15.88	15.9	25.40 <sup>+0.003</sup> <sub>-0.003</sub>	15.9	∅ 4 H7 x 6 Dp	M5 x 4 Dp	M5 x 8 Dp	M5 x 5 Dp	M5 x 6 Dp	∅ 5 H7 x 5 Dp	∅ 11 x 7 Dp C'bore (for M6 SHCS)	M5 x 8 Dp (8 Places)

Dimensions in millimeters

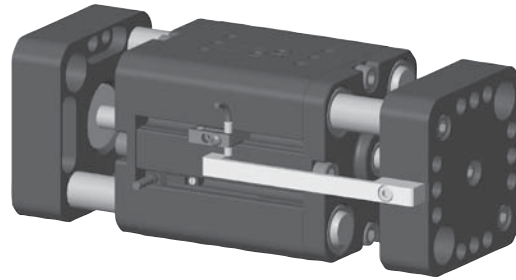


For inventory, lead time, and kit lookup, visit [www.pdnplu.com](http://www.pdnplu.com)

**Features**

**P5GS Parallel Wide Body Series**

- C-bores on inside of jaws for thru mounting to increase range of applications
- Standard sensor mounting slots for magneto resistive and inductive sensors (sensors sold separately)
- End of stroke cushions reduce shock of fully open and close strokes
- Each jaw is supported by 2 shafts that extend the entire length of the body and are guided by 2 oil impregnated bronze bushings per shaft
- Hardened precision stainless steel shafting for wear resistance and long life
- Magneto resistive sensors are an alternative option to inductive sensors (magnets supplied standard)
- Top air ports can be o-ring manifold sealed to eliminate air lines
- 2 standard air port locations (front and top)
- Slip fit dowel pin holes in body and jaws
- Large jaw configuration allows for simplified finger mounting



**Operating information**

Operating pressure:	3 to 7 bar (44 to 102 PSIG)
Temperature range:	
Nitrile seals (Standard)	-35° to 80° C (-30° to 180° F)
Filtration requirements:	
Air filtration	40 micron or better
Air lubrication	Not necessary*
Air humidity	Low moisture content (dry)
*Addition of lubrication will greatly increase service life	

**Ordering Information: P5GS Wide Body Series**

Function	Bore size (mm)	Ports (BSPP)	Stroke (mm)	Grip force @ 7 bar (N)	Accuracy +/- mm	Repeatability +/-mm	Weight (kg)	Part number
Double acting magnetic	16	M3	19.1	222	0.08	0.03	0.30	<b>P5GS-016MSG019B</b>
Double acting magnetic	16	M3	31.8	222	0.08	0.03	0.39	<b>P5GS-016MSG032B</b>
Double acting magnetic	24	M5	25.4	445	0.08	0.03	0.81	<b>P5GS-024MSG025B</b>
Double acting magnetic	24	M5	50.8	445	0.08	0.03	1.20	<b>P5GS-024MSG051B</b>
Double acting magnetic	32	M5	38.1	800	0.08	0.03	1.48	<b>P5GS-032MSG038B</b>
Double acting magnetic	32	M5	73.5	800	0.08	0.03	2.0	<b>P5GS-032MSG074B</b>

Sensor part numbers: Page F52.

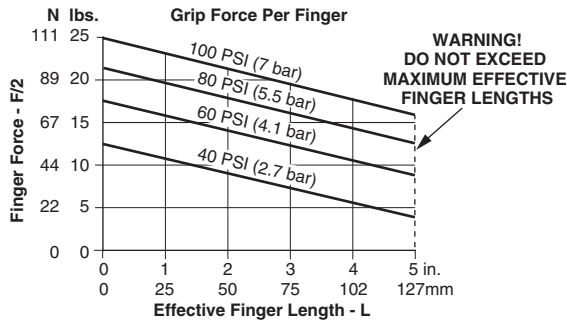
☐ Most popular.

**Automation Products**  
**Grippers**  
**Slide Tables**  
**Rotary Tables**  
**Escapements**  
**Sensors & Fittings**

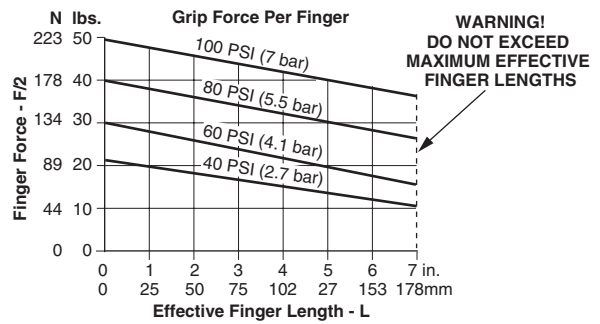


For inventory, lead times, and kit lookup, visit [www.pdnplu.com](http://www.pdnplu.com)

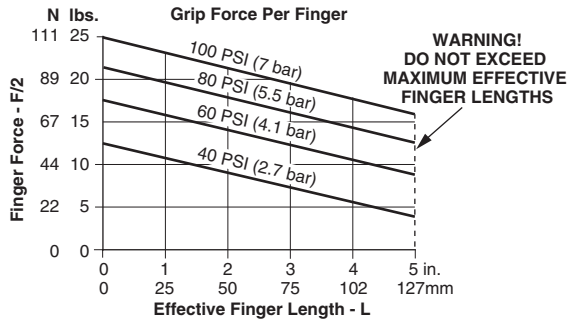
**Loading information - P5GS-016MSG019B**



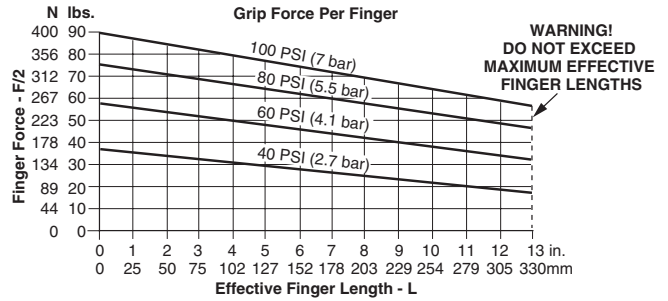
**Loading information - P5GS-024MSG051B**



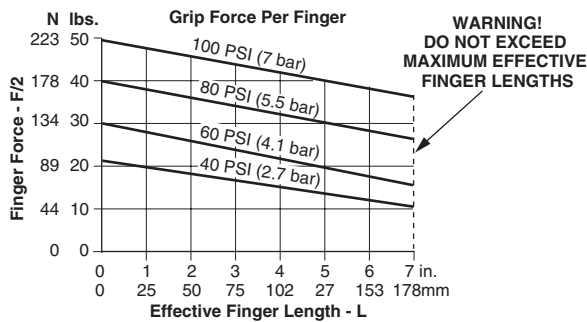
**Loading information - P5GS-016MSG032B**



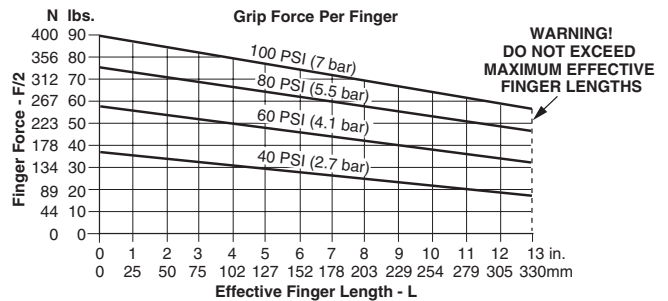
**Loading information - P5GS-032MSG038B**



**Loading information - P5GS-024MSG025B**



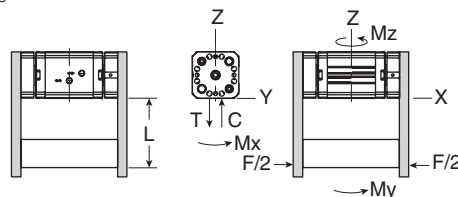
**Loading information - P5GS-032MSG074B**



**Loading capacity† - P5GS Wide Body Series**

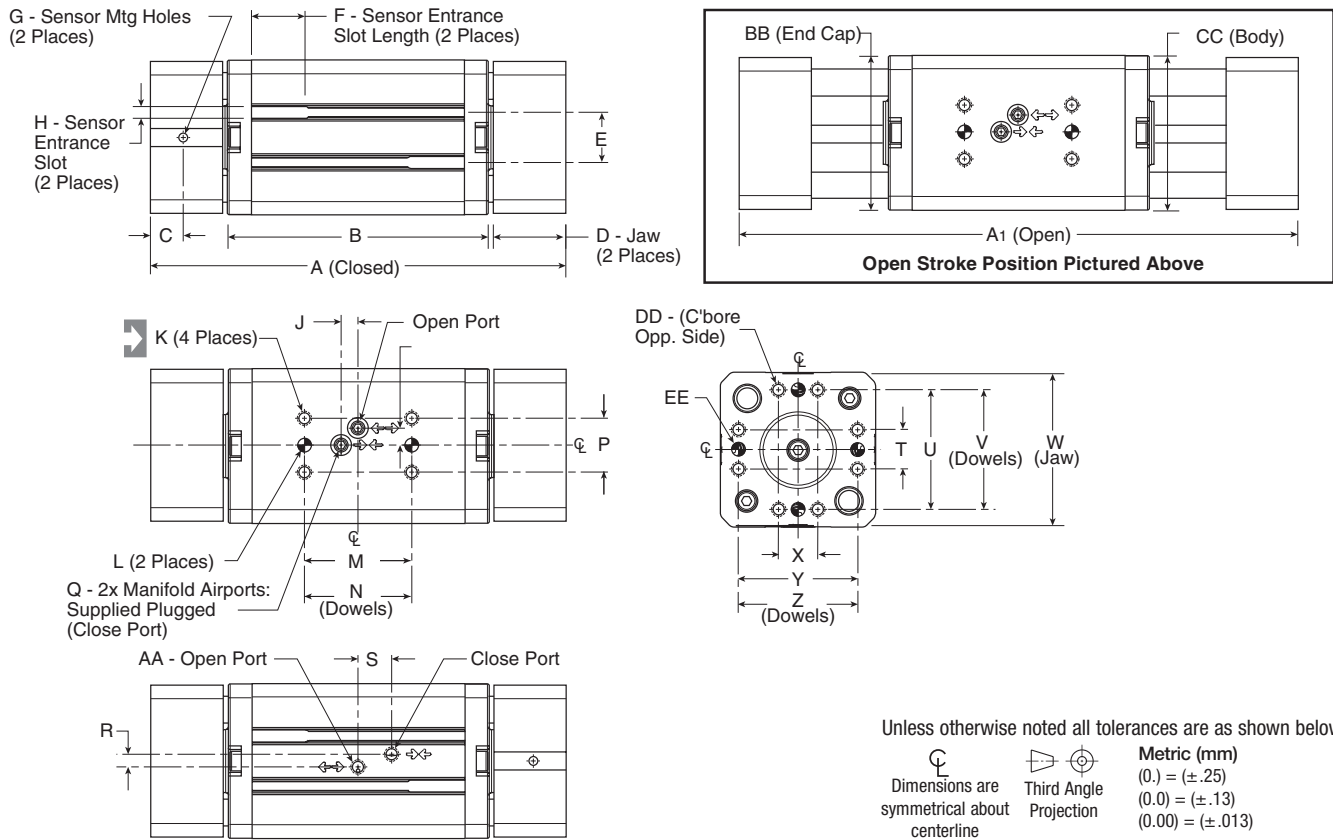
	P5GS-016M***19B		P5GS-016M***32B		P5GS-024M***25B		P5GS-024M***51B		P5GS-032M***38B		P5GS-032M***74B	
	Static (metric)	Dynamic (metric)	Static (metric)	Dynamic (metric)	Static (metric)	Dynamic (metric)	Static (metric)	Dynamic (metric)	Static (metric)	Dynamic (metric)	Static (metric)	Dynamic (metric)
Maximum tensile T	267 N	53 N	267 N	53 N	534 N	107 N	534 N	107 N	2668 N	267 N	2668 N	267 N
Maximum compressive C	267 N	53 N	267 N	53 N	534 N	107 N	534 N	107 N	2668 N	267 N	2668 N	267 N
Maximum moment Mx	14 Nm	3 Nm	14 Nm	3 Nm	24 Nm	5 Nm	24 Nm	5 Nm	68 Nm	7 Nm	68 Nm	7 Nm
Maximum moment My	20 Nm	4 Nm	20 Nm	4 Nm	34 Nm	7 Nm	34 Nm	7 Nm	102 Nm	10 Nm	102 Nm	10 Nm
Maximum moment Mz	14 Nm	3 Nm	14 Nm	3 Nm	24 Nm	5 Nm	24 Nm	5 Nm	68 Nm	7 Nm	68 Nm	7 Nm

† Capacities are per set of jaws and are not simultaneous



For inventory, lead time, and kit lookup, visit [www.pdnplu.com](http://www.pdnplu.com)

**Dimensions: P5GS Wide Body Series**



Part number	A	A <sub>1</sub>	B	C	D	E	F	G	H	J	K	L	M	N	P	Q
<b>P5GS-016MSG019B</b>	79	98	54.4	5.8	10.5	7.9	19.1	M3 x 3 Dp	4.2	4	M3 x 5 Dp	∅ 3h7 x 5 Dp	19.0	19.05	9.5	M3 x 5 Dp
<b>P5GS-016MSG032B</b>	104	136	67.1	7.3	16.9	7.9	19.1	M3 x 3 Dp	4.2	4	M3 x 5 Dp	∅ 3h7 x 5 Dp	19.1	19.05	9.5	M3 x 5 Dp
<b>P5GS-024MSG025B</b>	97	122	67.1	6.7	13.0	17.8	19.1	M3 x 4 Dp	4.2	6	M3 x 7 Dp	∅ 5h7 x 5 Dp	38.1	38.10	19.1	M5 x 7 Dp
<b>P5GS-024MSG051B</b>	147	198	92.5	11.7	25.7	17.8	19.1	M3 x 4 Dp	4.2	6	M3 x 7 Dp	∅ 5h7 x 5 Dp	38.1	38.10	19.1	M5 x 7 Dp
<b>P5GS-032MSG038B</b>	125	164	82.8	12.1	19.2	18.8	19.1	M3 x 4 Dp	4.2	6	M3 x 8 Dp	∅ 5h7 x 5 Dp	38.1	38.10	19.1	M5 x 5 Dp
<b>P5GS-032MSG074B</b>	177	240	108.2	14.9	39.1	18.8	19.1	M3 x 4 Dp	4.2	6	M3 x 8 Dp	∅ 5h7 x 5 Dp	38.1	38.10	19.1	M5 x 7 Dp

Part number	R	S	T	U	V	W	X	Y	Z	AA	BB	CC	DD	EE
<b>P5GS-016MSG019B</b>	6	10	10.0	30.0	30.00	37.6	10.0	30.0	30.00	M5 x 5 Dp	37.6	38.0	M4 x 8 Dp	∅ 4h7 x 5 Dp
<b>P5GS-016MSG032B</b>	6	12	10.0	30.0	30.00	37.6	10.0	30.0	30.00	M5 x 5 Dp	37.6	38.0	M4 x 8 Dp	∅ 4h7 x 5 Dp
<b>P5GS-024MSG025B</b>	5	11	14.0	42.5	42.50	54.0	14.0	42.5	42.50	M5 x 6 Dp	54.7	55.0	M5 x 10 Dp	∅ 5h7 x 5 Dp
<b>P5GS-024MSG051B</b>	5	12	14.0	42.5	42.50	54.0	14.0	42.5	42.50	M5 x 6 Dp	54.7	55.0	M5 x 10 Dp	∅ 5h7 x 5 Dp
<b>P5GS-032MSG038B</b>	5	15	18.0	51.0	51.00	63.0	18.0	51.0	51.00	M5 x 6 Dp	63.7	64.0	M6 x 13 Dp	∅ 6h7 x 8 Dp
<b>P5GS-032MSG074B</b>	5	15	18.0	51.0	51.00	63.0	18.0	51.0	51.00	M5 x 6 Dp	63.7	64.0	M6 x 13 Dp	∅ 6h7 x 8 Dp

Dimensions in millimeters

**Automation Products**  
**Grippers**  
**Slide Tables**  
**Rotary Tables**  
**Escapements**  
**Sensors & Fittings**



For inventory, lead times, and kit lookup, visit [www.pdnplu.com](http://www.pdnplu.com)

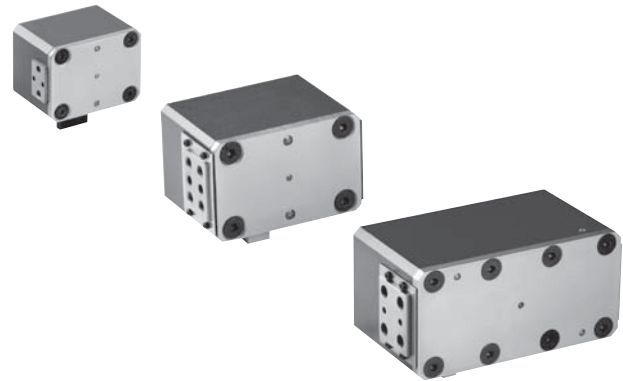
F24

**Parker Hannifin Corporation**  
 Pneumatic Division  
 Richland, Michigan  
[www.parker.com/pneumatics](http://www.parker.com/pneumatics)

**Features**

**P5GT Parallel Double Wedge Series**

- Extremely compact and robust package
- One piece 7075 -T6 aircraft quality aluminum body
- Dynamic components are hardened for wear resistance and long life
- Accessory mounting holes mount sensors to unit
- Slip fit dowel pin holes in body and jaws
- Jaws are supported throughout the length of the body and are precision ground for minimal jaw play
- A double acting piston is connected by a shaft to a double sided wedge
- The wedge slides in a slot located in each of the jaws converting vertical motion of the wedge into horizontal synchronous motion of the jaws
- The large surface area of the wedge minimizes frictional wear
- Magnetic piston standard



Operating information	
Operating pressure:	3 to 7 bar (44 to 102 PSIG)
Temperature range:	
Nitrile seals (standard)	-35° to 80° C (-30° to 180° F)
Fluorocarbon seals (optional)	-30° to 150° C (-20° to 300° F)
Filtration requirements:	
Air filtration	40 micron or better
Air lubrication	Not necessary*
Air humidity	Low moisture content (dry)
*Addition of lubrication will greatly increase service life	

**Ordering Information: P5GT Double Wedge Series**

Function	Bore size (mm)	Ports (BSPP)	Stroke (mm)	Grip force @ 7 bar (N)	Accuracy +/- mm	Repeatability +/-mm	Weight (kg)	Part number
Double acting magnetic, Nitrile	25	M5	6.4	178	0.05	0.03	0.12	<b>P5GT-025MSG006B</b>
Double acting magnetic, Fluorocarbon	25	M5	6.4	178	0.05	0.03	0.12	<b>P5GT-025MFG006B</b>
Double acting magnetic, Nitrile	25	M5	9.5	178	0.05	0.03	0.25	<b>P5GT-025MSG010B</b>
Double acting magnetic, Fluorocarbon	25	M5	9.5	178	0.05	0.03	0.25	<b>P5GT-025MFG010B</b>
Double acting magnetic, Nitrile	32	M5	12.7	311	0.05	0.03	0.57	<b>P5GT-032MSG013B</b>
Double acting magnetic, Fluorocarbon	32	M5	12.7	311	0.05	0.03	0.57	<b>P5GT-032MFG013B</b>
Double acting magnetic, Nitrile	46	1/8	19.1	979	0.08	0.03	1.0	<b>P5GT-046MSG019B</b>
Double acting magnetic, Fluorocarbon	46	1/8	19.1	979	0.08	0.03	1.0	<b>P5GT-046MFG019B</b>
Double acting magnetic, Nitrile	64	1/8	31.8	1779	0.08	0.03	3.5	<b>P5GT-064MSG032B</b>
Double acting magnetic, Fluorocarbon	64	1/8	31.8	1779	0.08	0.03	3.5	<b>P5GT-064MFG032B</b>
Double acting magnetic, Nitrile	89	1/4	50.8	2669	0.08	0.03	9.5	<b>P5GT-089MSG051B</b>
Double acting magnetic, Fluorocarbon	89	1/4	50.8	2669	0.08	0.03	9.5	<b>P5GT-089MFG051B</b>

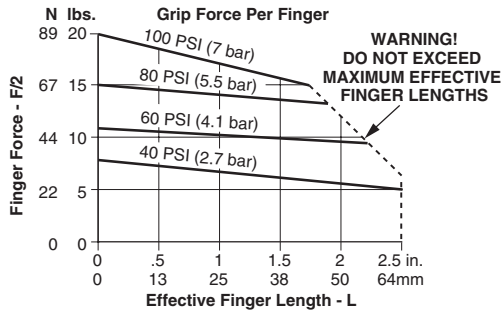
Sensor part numbers: Page F52.

Most popular.

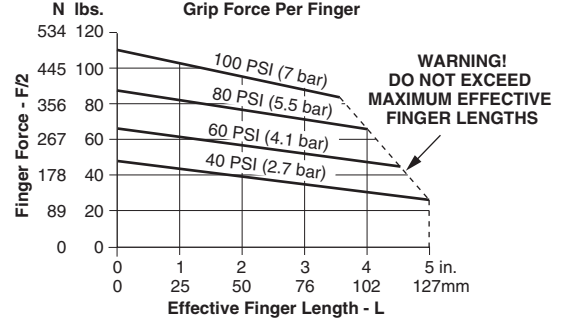


For inventory, lead time, and kit lookup, visit [www.pdnplu.com](http://www.pdnplu.com)

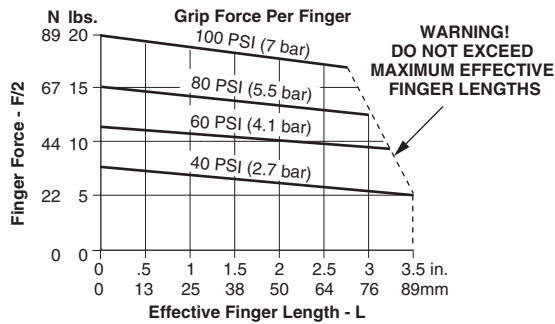
**Loading information - P5GT-025/006**



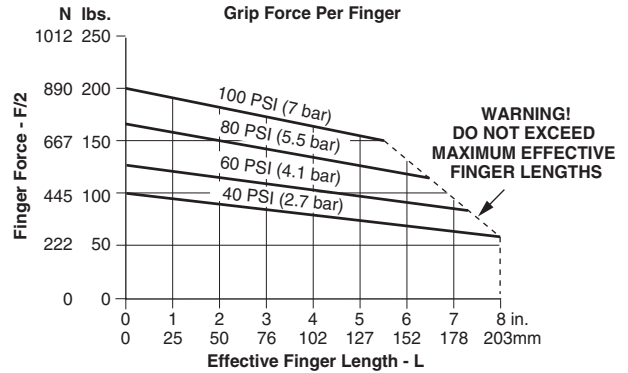
**Loading information - P5GT-046**



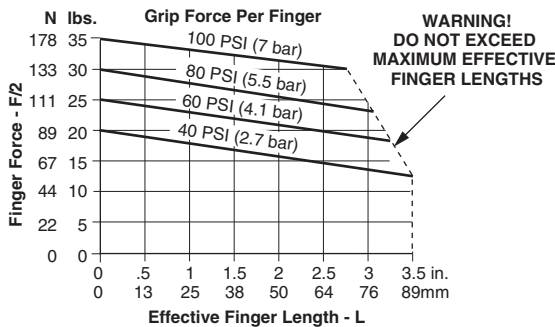
**Loading information - P5GT-025/010**



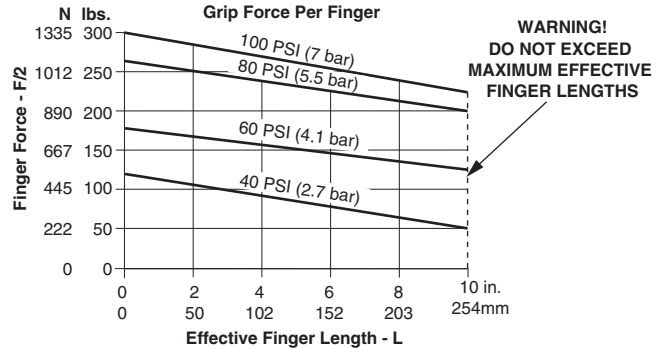
**Loading information - P5GT-064**



**Loading information - P5GT-032**



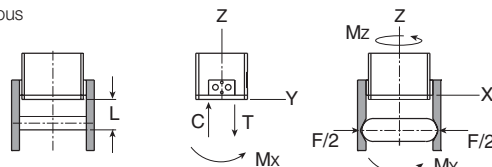
**Loading information - P5GT-089**



**Loading capacity† - P5GT Double Wedge Series**

	P5GT-025(006)		P5GT-025(010)		P5GT-032		P5GT-046		P5GT-064		P5GT-089	
	Static (metric)	Dynamic (metric)	Static (metric)	Dynamic (metric)	Static (metric)	Dynamic (metric)	Static (metric)	Dynamic (metric)	Static (metric)	Dynamic (metric)	Static (metric)	Dynamic (metric)
Maximum tensile T	445 N	111 N	890 N	111 N	1779 N	222 N	3336 N	445 N	6672 N	1112 N	13345 N	1334 N
Maximum compressive C	890 N	111 N	1779 N	111 N	3336 N	222 N	6672 N	445 N	13345 N	1112 N	26689 N	1334 N
Maximum moment Mx	11 Nm	2 Nm	17 Nm	3 Nm	34 Nm	6 Nm	85 Nm	14 Nm	170 Nm	28 Nm	565 Nm	56 Nm
Maximum moment My	11 Nm	2 Nm	17 Nm	3 Nm	34 Nm	6 Nm	85 Nm	14 Nm	170 Nm	28 Nm	565 Nm	56 Nm
Maximum moment Mz	11 Nm	2 Nm	17 Nm	3 Nm	34 Nm	6 Nm	85 Nm	14 Nm	170 Nm	28 Nm	565 Nm	56 Nm

† Capacities are per set of jaws and are not simultaneous



For inventory, lead times, and kit lookup, visit [www.pdnplu.com](http://www.pdnplu.com)

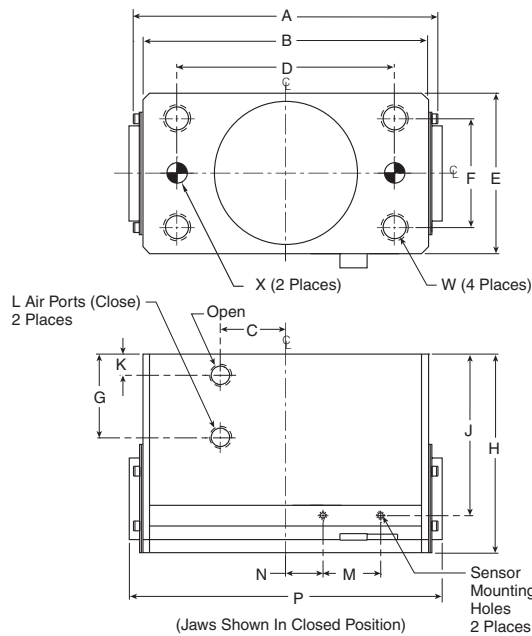
F26

**Parker Hannifin Corporation**  
 Pneumatic Division  
 Richland, Michigan  
[www.parker.com/pneumatics](http://www.parker.com/pneumatics)

Automation Products  
 Grippers  
 Slide Tables  
 Rotary Tables  
 Escapements  
 Sensors & Fittings



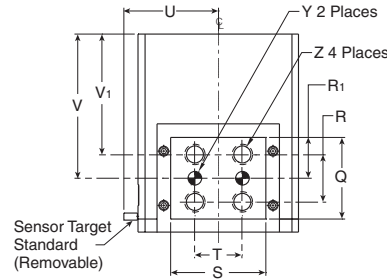
**Dimensions: P5GT Double Wedge Series**



Unless otherwise noted all tolerances are as shown below

Dimensions are symmetrical about centerline  
 Third Angle Projection

**Metric (mm)**  
 (0.) = (±.25)  
 (0.0) = (±.13)  
 (0.00) = (±.013)



Part number	A	B	C	D	E	F	G	H	J	K	L	M	N	P	Q
<b>P5GT-025(006)</b>	–	38.1	20	31.75	31.8	12.70	17	28.6	9	5	M5	25	–	Open 48 Closed 41	9.55 <sup>+0.00</sup> / <sub>-.003</sub>
<b>P5GT-025(010)</b>	–	50.8	23	38.10	38.1	25.40	12	35.6	14	9	M5	14	6	Open 63 Closed 54	12.34 <sup>+0.00</sup> / <sub>-.003</sub>
<b>P5GT-032</b>	70.4	63.50	30	50.80	41.3	19.05	14.4	47.3	18	7	M5	17	3	Open 81 Closed 68	18.69 <sup>+0.00</sup> / <sub>-.003</sub>
<b>P5GT-046</b>	89.6	82.55	25	63.50	54.0	25.40	25	61.9	46	8	G1/8	27	5	Open 108 Closed 85	25.43 <sup>+0.00</sup> / <sub>-.003</sub>
<b>P5GT-064</b>	142.2	133.35	–	101.60	74.9	50.8	39	92.8	75	10	G1/8	27	17	Open 177 Closed 146	38.10 <sup>+0.00</sup> / <sub>-.003</sub>
<b>P5GT-089</b>	214.7	203.20	–	152.40	100.3	69.9	47	118.2	98	11	G1/4	56	25	Open 266 Closed 216	47.63 <sup>+0.00</sup> / <sub>-.003</sub>

Part number	R	S	T	U	V	W	X	Y	Z	Z1
<b>P5GT-025(006)</b>	6.35	15.88 <sup>+0.00</sup> / <sub>-.003</sub>	7.9	22.2	21.5	M4 x 9 Dp	Ø 3H7 x 6 Dp	Ø 2H7 x 4 Dp	M4 x 4.7 Dp	M3 x 4 Dp
<b>P5GT-025(010)</b>	7.95	18.67 <sup>+0.00</sup> / <sub>-.003</sub>	12.7	25.4	26.3	M6 x 12 Dp	Ø 5H7 x 6 Dp	Ø 2.5H7 x 4 Dp	M4 x 7 Dp	M3 x 4 Dp
<b>P5GT-032</b>	9.53	25.01 <sup>+0.00</sup> / <sub>-.003</sub>	17.5	27.0	28.5	M6 x 12 Dp	Ø 5H7 x 6 Dp	Ø 4H7 x 4 Dp	M5 x 9 Dp	M3 x 4 Dp
<b>P5GT-046</b>	12.70	31.78 <sup>+0.00</sup> / <sub>-.003</sub>	19.1	33.3	38.1	M10 x 19 Dp	Ø 6H7 x 12 Dp	Ø 5H7 x 9 Dp	M6 x 12 Dp	M3 x 6 Dp
<b>P5GT-064</b>	22.2	44.48 <sup>+0.00</sup> / <sub>-.003</sub>	22.23	44.2	67.4	M12 x 25 Dp	Ø 10H8 x 12 Dp	Ø 8H7 x 12 Dp	M10 x 19 Dp	M3 x 9 Dp
<b>P5GT-089</b>	28.57	57.10 <sup>+0.00</sup> / <sub>-.003</sub>	34.9	56.9	70.7	M20 x 38 Dp	Ø 12H8 x 19 Dp	Ø 6H7 x 12 Dp	M12 x 28 Dp	M3 x 9 Dp

Dimensions in millimeters

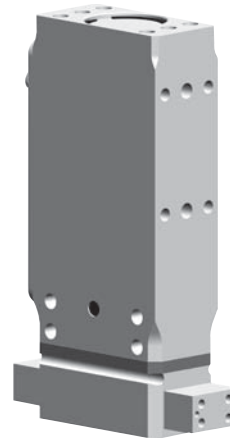


For inventory, lead time, and kit lookup, visit [www.pdnplu.com](http://www.pdnplu.com)

**Features**

**P5GP Electric Series**

- One piece, lightweight aircraft quality aluminum body ensures product accuracy
- The body and jaws are hard-coat anodized to 60 RC with PTFE impregnation
- Ridged design and full body support of the jaws allows for long finger lengths
- Versatile mounting on top, side front and back of body.
- IP54 rating for tough application environments
- Slip fit dowel pin holes located in body and jaws for precision mounting
- Precision rack and pinion drive components for smooth actuation. Zero backlash while gripping ensures excellent repeatability and accuracy.
- Built in electronics, no external control board needed
- Magnetic piston standard



**Operating information**

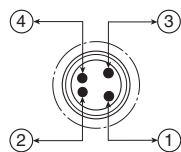
Voltage:	24VDC
Power Req. @ 100% Duty Cycle:	4.2 Watts
Current - Peak:	1.5 Amps Max.
Current - Continuous:	0.175 Amps
Temperature range:	5° to 60° C (41° to 140° F)

**Ordering Information: P5GP Electric Gripper Series**

Function	Stroke (mm)	Grip force (N)	Accuracy +/- mm	Repeatability +/-mm	Weight (kg)	Part number
Electric	25	111	0.051	0.025	0.53	<b>P5GP-000ESX025B</b>

Sensor part numbers: Page F52.

**Electrical Interface**



Pin Out (Looking Into Header Connector On Gripper)

- 1 ..... Brown (+ 24 VDC)
- 2 ..... White (Open Gripper) +24 VDC = Active
- 3 ..... Blue (Ground)
- 4 ..... Black (Close Gripper) +24 VDC = Active

**4-Wire Power & Signal Cable: P8S-CABL-046**

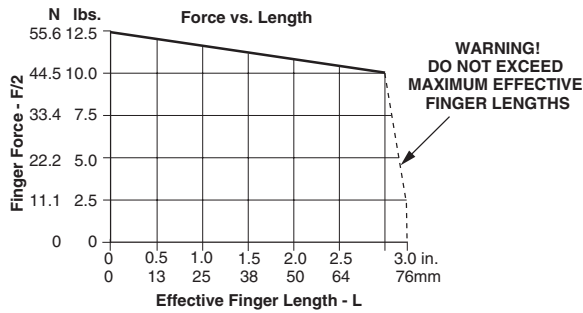
☐ Most popular.

**Automation Products**  
**Grippers**  
**Slide Tables**  
**Rotary Tables**  
**Escapements**  
**Sensors & Fittings**



For inventory, lead times, and kit lookup, visit [www.pdnplu.com](http://www.pdnplu.com)

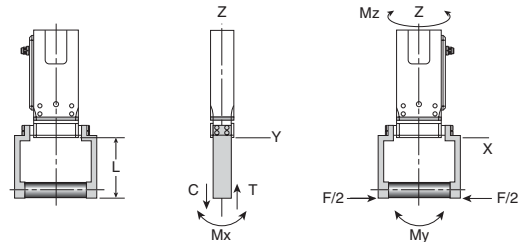
**Loading information - P5GP-000**



**Loading capacity† - P5GP Electric Gripper**

	Static (metric)
Maximum tensile T	10 N
Maximum compressive C	10 N
Maximum moment Mx	14 Nm
Maximum moment My	17 Nm
Maximum moment Mz	14 Nm

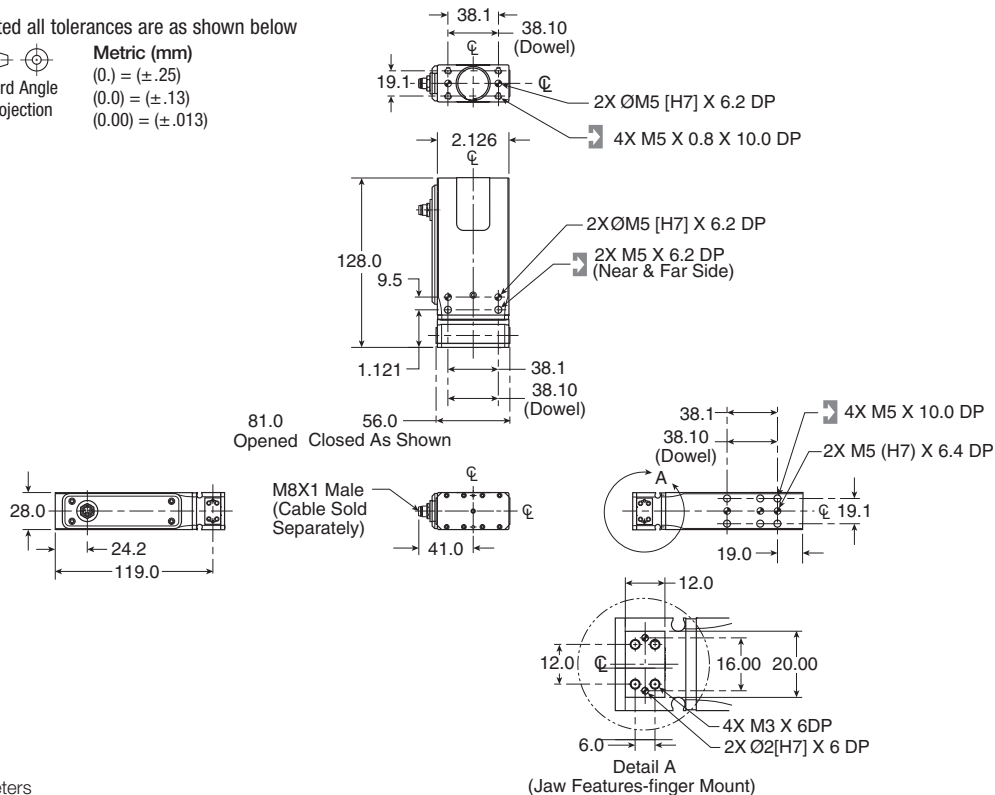
† Capacities are per set of jaws and are not simultaneous



**Dimensions: P5GP Electric Gripper Series**

Unless otherwise noted all tolerances are as shown below

- ⌀ Dimensions are symmetrical about centerline
- Third Angle Projection
- Metric (mm)  
 (0.) = (±.25)  
 (0.0) = (±.13)  
 (0.00) = (±.013)



Dimensions in millimeters

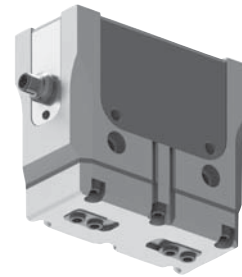


For inventory, lead time, and kit lookup, visit [www.pdnplu.com](http://www.pdnplu.com)

**Features**

**P5GQ Electric Series, High Force**

- Gripper is available in two stroke lengths, standard and extended stroke
- Ridged design and full body support of the jaws allows for long finger lengths
- Finger locating sleeves for precise finger mounting (standard)
- Slip fit dowel pin holes located in body and jaws for precision mounting
- Jaw components hardened and precision ground steel for minimum jaw play with hard plating for wear resistance and long life
- IP50
- Grip force can be changed on the fly using 0-5V analog input
- No external controller needed, 8-pin cable sold separately
- Magnetic piston standard



**Operating information**

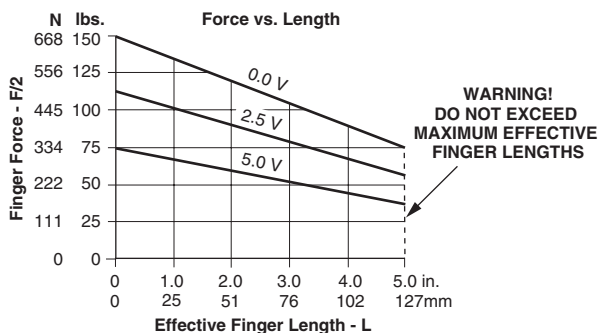
Voltage:	24VDC
Power Req. @ 100% Duty Cycle:	10 Watts
Current - Peak:	2 Amps Max.
Current - Continuous:	0.4 Amps
Temperature range:	0° to 55° C (32° to 131° F)

**Ordering Information: P5GQ Electric Gripper Series - High Force**

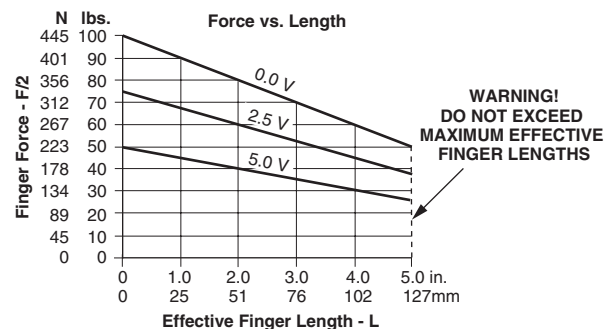
Function	Gripping mode	Stroke (mm)	Grip force @ 7 bar (N)	Accuracy +/- mm	Repeatability +/-mm	Weight (kg)	Part number
Electric	ID	10.0	667-1334	0.05	0.025	2.52	<b>P5GQ-000RSX010B</b>
Electric	ID	20.0	445-890	0.05	0.025	2.52	<b>P5GQ-000RSX020B</b>
Electric	OD	10.0	667-1334	0.05	0.025	2.52	<b>P5GQ-000QSX010B</b>
Electric	OD	20.0	445-890	0.05	0.025	2.52	<b>P5GQ-000QSX020B</b>

Sensor part numbers: Page F52.

**Loading information - P5GQ-000\*010**



**Loading information - P5GQ-000\*020**



**Loading capacity† - P5GQ-000\*010**

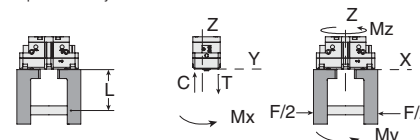
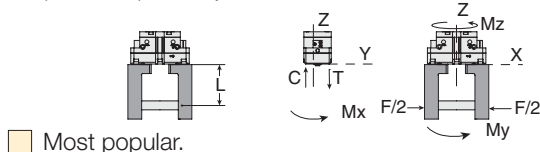
	Static (metric)	Dynamic (Metric)
Maximum tensile T	1564 N	259 N
Maximum compressive C	2070 N	259 N
Maximum moment Mx	76 Nm	10 Nm
Maximum moment My	106 Nm	14 Nm
Maximum moment Mz	70 Nm	14 Nm

† Capacities are per set of jaws and are not simultaneous

**Loading capacity† - P5GQ-000\*020**

	Static (metric)	Dynamic (Metric)
Maximum tensile T	1394 N	168 N
Maximum compressive C	1845 N	168 N
Maximum moment Mx	68 Nm	6 Nm
Maximum moment My	84 Nm	8 Nm
Maximum moment Mz	56 Nm	8 Nm

† Capacities are per set of jaws and are not simultaneous



For inventory, lead times, and kit lookup, visit [www.pdnplu.com](http://www.pdnplu.com)

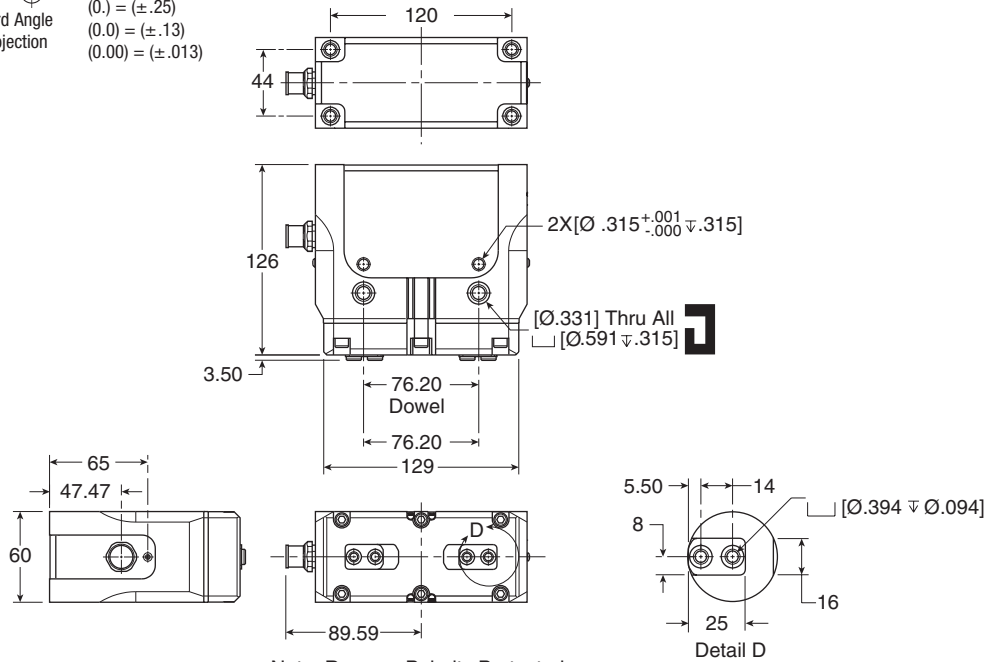
Automation Products  
 Grippers  
 Slide Tables  
 Rotary Tables  
 Escapements  
 Sensors & Fittings

**Technical Data**

**Dimensions: P5GQ Electric Gripper Series - High Force**

Unless otherwise noted all tolerances are as shown below

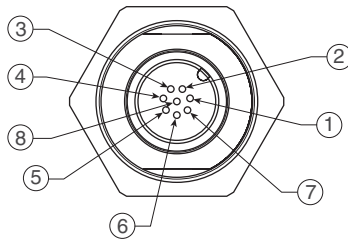
Dimensions are symmetrical about centerline  
 Third Angle Projection  
**Metric (mm)**  
 (0.) = (±.25)  
 (0.0) = (±.13)  
 (0.00) = (±.013)



Dimensions in millimeters

**P8S-CABL-052:** 8 Wire power and signal cable, 5m long, straight M12 connector

**P8S-CABL-053:** 8 Wire power and signal cable, 5m long, 90 degree M12 connector



**Electrical interface: Pin out (Looking into the head of the connector on gripper)**

Pin #	Color	Signal	Description	Current
1	White	Force	0-5 VDC (Analog)	5mA
2	Brown	+24V	Motor power	2A (max), 0.4 A (avg)
3	Green	Open	24 VDC active (Inputs)	10mA
4	Yellow	Open sense	NPN / PNP (Outputs)	300mA (max)
5	Gray	Close	24 VDC active (Inputs)	10mA
6	Pink	Close sense	NPN / PNP (Outputs)	300mA (max)
7	Blue	Ground	Motor ground	2A (max)
8	Red	I/O power	24 VDC (PNP outputs only)	300mA (max)



For inventory, lead time, and kit lookup, visit [www.pdnplu.com](http://www.pdnplu.com)

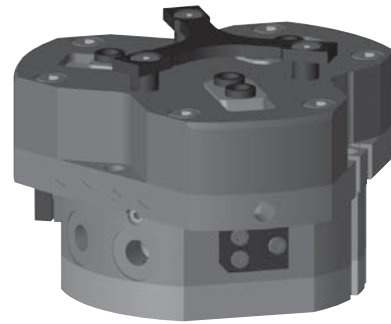
F31

**Parker Hannifin Corporation**  
 Pneumatic Division  
 Richland, Michigan  
[www.parker.com/pneumatics](http://www.parker.com/pneumatics)

**Features**

**P5GW 3-Jaw Centering Series**

- Multiple side or top air ports (top ports require o-ring)
- Optional spring assist retains the component should the air supply fail, to assist the gripper for internal (-O) or external (-C) gripping, or in single acting or spring assist mode
- Finger locating sleeves for precise finger mounting
- Jaw components hardened and precision ground steel for minimum jaw play with hard plating for wear resistance and long life
- Standard purge / scavenge port used with vacuum for clean room environments or positive pressure for harsh environments
- Gripper can be mounted from the top or bottom
- Gripper body is shielded to repel chips and other particulate from internal drive mechanism
- Magnetic piston standard



**Operating information**

Operating pressure:	0.3 to 7 bar (4 to 102 PSIG)
Temperature range:	
Nitrile seals (Standard)	-35° to 80° C (-30° to 180° F)
Fluorocarbon seals (Optional)	-30° to 150° C (-20° to 300° F)
Filtration requirements:	
Air filtration	40 micron or better
Air lubrication	Not necessary*
Air humidity	Low moisture content (dry)
*Addition of lubrication will greatly increase service life	

**Ordering Information: P5GW 3-Jaw Centering Series**

Function	Bore size (mm)	Stroke (mm)	Grip force @ 7 bar (N)	Accuracy +/- mm	Repeatability +/-mm	Weight (kg)	Part number Fluorocarbon	Part number Nitrile
Double acting magnetic	32	4.0	682	0.04	0.02	0.25	<b>P5GW-032MFG004B</b>	<b>P5GW-032MSG004B</b>
Double acting magnetic	43	6.0	1238	0.04	0.02	0.53	<b>P5GW-043MFG006B</b>	<b>P5GW-043MSG006B</b>
Double acting magnetic	55	8.0	2078	0.04	0.02	1.08	<b>P5GW-055MFG008B</b>	<b>P5GW-055MSG008B</b>
Double acting magnetic	72	10.0	3644	0.06	0.03	1.95	<b>P5GW-072MFG010B</b>	<b>P5GW-072MSG010B</b>
Double acting magnetic	95	13.0	6353	0.06	0.03	3.9	<b>P5GW-095MFG013B</b>	<b>P5GW-095MSG013B</b>
Double acting magnetic	120	16.0	10202	0.08	0.04	7.89	<b>P5GW-120MFG016B</b>	<b>P5GW-120MSG016B</b>
Double acting magnetic	156	25.0	17165	0.10	0.05	15.7	<b>P5GW-156MFG025B</b>	<b>P5GW-156MSG025B</b>
Double acting magnetic	225	35.0	35288	0.10	0.05	43.9	<b>P5GW-225MFG035B</b>	<b>P5GW-225MSG035B</b>

Function	Bore size (mm)	Stroke (mm)	Grip force @ 7 bar (N)	Accuracy +/- mm	Repeatability +/-mm	Weight (kg)	Part number Spring close
Spring closing magnetic	32	4.0	889	0.04	0.02	0.25	<b>P5GW-032DSG004B</b>
Spring closing magnetic	43	6.0	1490	0.04	0.02	0.53	<b>P5GW-043DSG006B</b>
Spring closing magnetic	55	8.0	2627	0.04	0.02	1.08	<b>P5GW-055DSG008B</b>
Spring closing magnetic	72	10.0	4562	0.06	0.03	1.95	<b>P5GW-072DSG010B</b>
Spring closing magnetic	95	13.0	7877	0.06	0.03	3.9	<b>P5GW-095DSG013B</b>
Spring closing magnetic	120	16.0	13786	0.08	0.04	7.89	<b>P5GW-120DSG016B</b>
Spring closing magnetic	156	25.0	22093	0.10	0.05	15.7	<b>P5GW-156DSG025B</b>
Spring closing magnetic	225	35.0	44354	0.10	0.05	43.9	<b>P5GW-225DSG035B</b>

Sensor part numbers: Page F52.

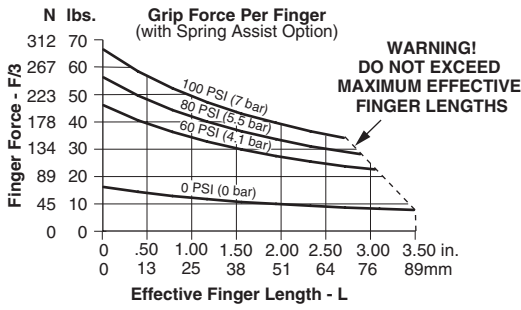
Most popular.

Automation Products  
 Grippers  
 Slide Tables  
 Rotary Tables  
 Escapements  
 Sensors & Fittings

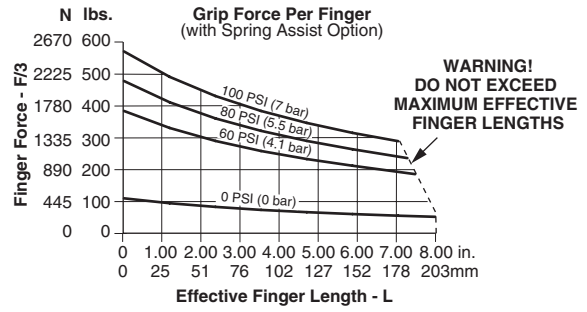


For inventory, lead times, and kit lookup, visit [www.pdnplu.com](http://www.pdnplu.com)

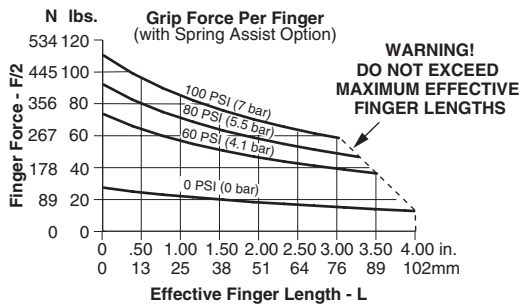
**Loading information - P5GW-032**



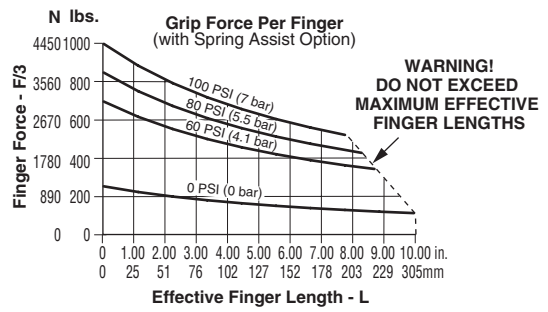
**Loading information - P5GW-095**



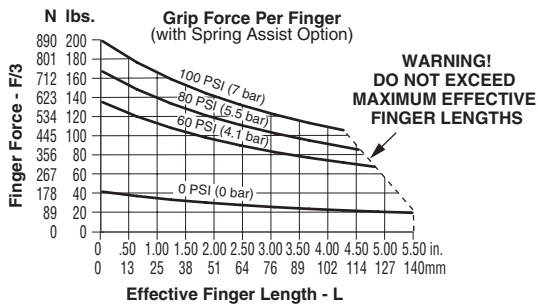
**Loading information - P5GW-043**



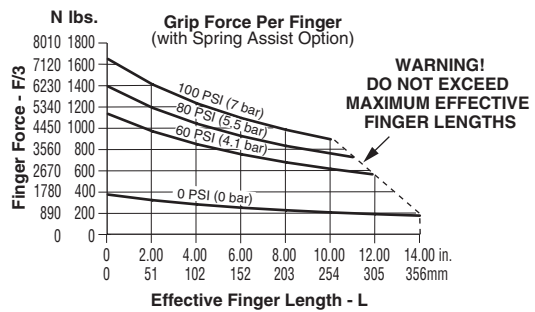
**Loading information - P5GW-120**



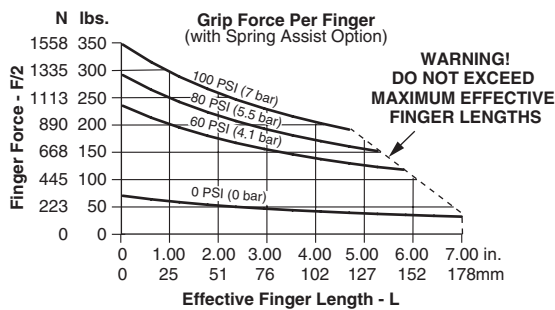
**Loading information - P5GW-055**



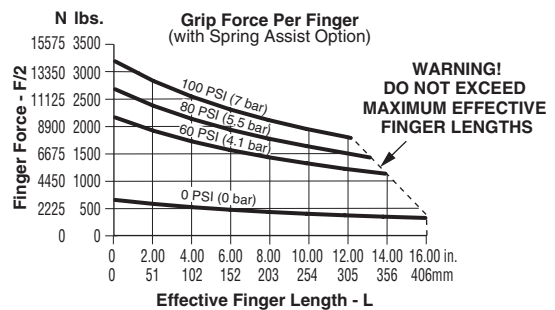
**Loading information - P5GW-156**



**Loading information - P5GW-072**



**Loading information - P5GW-225**



For inventory, lead time, and kit lookup, visit [www.pdnplu.com](http://www.pdnplu.com)

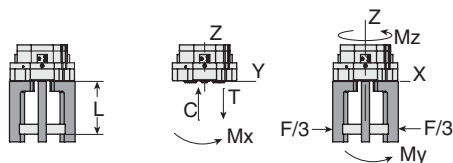
**Loading capacity† - P5GW 3-Jaw Centering Series**


	P5GW-32		P5GW-43		P5GW-55		P5GW-72	
	Static (metric)	Dynamic (metric)	Static (metric)	Dynamic (metric)	Static (metric)	Dynamic (metric)	Static (metric)	Dynamic (metric)
Maximum tensile T	810 N	89 N	1200 N	129 N	1680 N	302 N	2110 N	425 N
Maximum compressive C	1060 N	89 N	1560 N	129 N	2180 N	302 N	2790 N	425 N
Maximum moment Mx	22 Nm	2 Nm	45 Nm	4 Nm	72 Nm	11 Nm	92 Nm	16 Nm
Maximum moment My	28 Nm	3 Nm	64 Nm	6 Nm	102 Nm	16 Nm	182 Nm	22 Nm
Maximum moment Mz	18 Nm	3 Nm	41 Nm	6 Nm	66 Nm	16 Nm	84 Nm	22 Nm

	P5GW-95		P5GW-120		P5GW-156		P5GW-225	
	Static (metric)	Dynamic (metric)	Static (metric)	Dynamic (metric)	Static (metric)	Dynamic (metric)	Static (metric)	Dynamic (metric)
Maximum tensile T	2990 N	674 N	4320 N	1315 N	5400 N	1763 N	8230 N	2733 N
Maximum compressive C	3980 N	674 N	5810 N	1315 N	7120 N	1763 N	10700 N	2733 N
Maximum moment Mx	127 Nm	25 Nm	172 Nm	45 Nm	215 Nm	60 Nm	455 Nm	131 Nm
Maximum moment My	179 Nm	35 Nm	250 Nm	65 Nm	305 Nm	86 Nm	578 Nm	167 Nm
Maximum moment Mz	117 Nm	35 Nm	164 Nm	65 Nm	208 Nm	86 Nm	362 Nm	167 Nm

† Capacities are per set of jaws and are not simultaneous



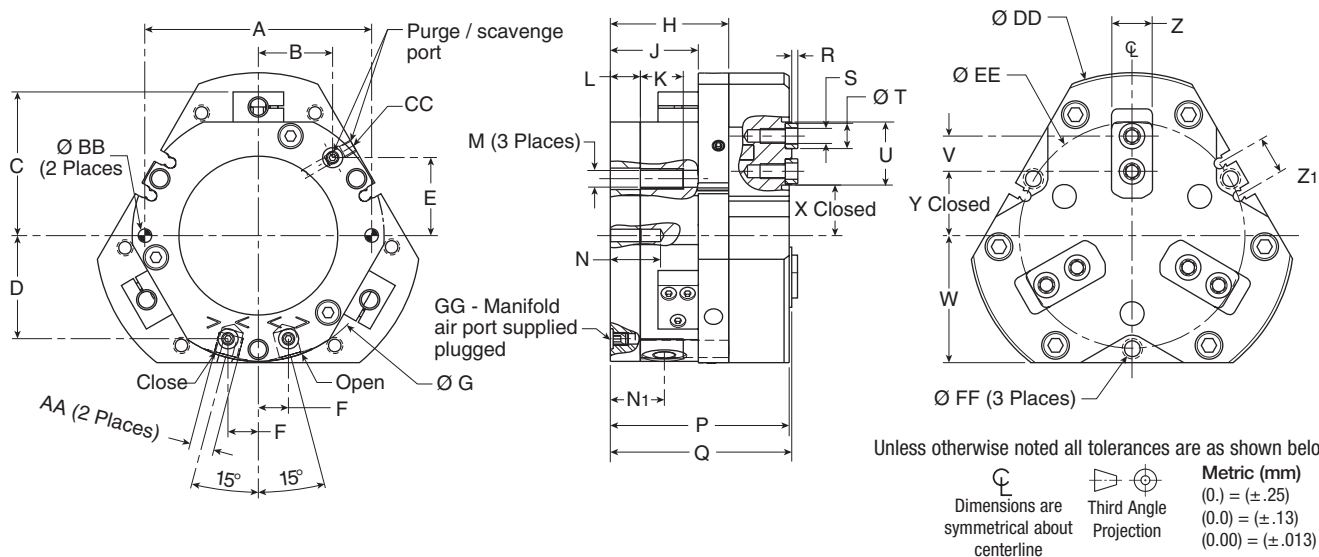
	Automation Products
Grippers	
Slide Tables	
Rotary Tables	
Escapements	
Sensors & Fittings	



For inventory, lead times, and kit lookup, visit [www.pdnplu.com](http://www.pdnplu.com)



**Dimensions: P5GW 3-Jaw Centering Series**



Part number	A	B	C	D	E	F	G	H	J	K	L	M	N	N <sub>1</sub>	P	Q	R	S
<b>P5GW-032</b>	45.00	13.4	—	19.5	15.8	7.0	51	24.5	18.5	9	6.0	M4	12	11.5	36.5	37.0	1.5	M3 x 5 Dp
<b>P5GW-043</b>	56.00	17.2	37.7	25.0	20.3	9.0	64	32.5	25.5	13	9.0	M6	15	15.5	48.5	49.0	1.5	M4 x 6 Dp
<b>P5GW-055</b>	70.00	23.2	46.7	32.0	23.8	9.0	80	43.5	33.5	17	12.0	M8	20	20.0	63.5	64.0	2.0	M5 x 9 Dp
<b>P5GW-072</b>	90.00	29.5	57.0	41.0	30.9	12.0	100	47.0	35.0	17	12.0	M8	20	21.5	71.0	72.0	2.5	M6 x 10 Dp
<b>P5GW-095</b>	112.00	38.4	71.0	53.0	39.5	15.0	125	57.0	42.0	22	14.0	M10	24	25.0	87.0	88.0	2.5	M6 x 10 Dp
<b>P5GW-120</b>	146.00	49.0	87.0	67.5	50.2	19.0	160	72.0	53.0	22	20.0	M10	30	33.0	109.0	110.0	3.0	M8 x 17 Dp
<b>P5GW-156</b>	184.00	64.3	106.0	87.5	63.7	23.0	200	92.0	70.0	26	24.0	M12	36	43.0	142.0	143.0	4.0	M12 x 17 Dp
<b>P5GW-225</b>	270.00	90.5	150.0	123.0	89.2	32.0	300	125.0	99.0	40	30.0	M20	46	60.0	195.0	196.0	5.0	M16 x 21 Dp

Part number	T	U	V	W	X	Y	Z	Z <sub>1</sub>	AA	BB	CC	DD	EE	FF	GG
<b>P5GW-032</b>	5h7	14.0	8.00	26.0	9.0	12.0	8.0	12.0	M5 x 5 Dp	3h7	M5 x 5 Dp	63	45	3.3	M3 x 4
<b>P5GW-043</b>	6h7	16.0	9.00	32.5	13.0	16.5	10.0	15.0	M5 x 5 Dp	4h7	M5 x 5 Dp	83	56	5.2	M3 x 4
<b>P5GW-055</b>	8h7	20.0	11.00	40.5	16.0	20.5	12.5	15.0	M5 x 5 Dp	5h7	M5 x 5 Dp	104	70	6.8	M4 x 6
<b>P5GW-072</b>	10h7	25.0	14.00	50.5	20.0	25.5	16.0	15.0	M5 x 5 Dp	5h7	M5 x 5 Dp	129	90	6.8	M5 x 6
<b>P5GW-095</b>	10h7	32.0	20.00	63.0	24.5	30.5	20.0	18.0	G1/8 x 8 Dp	6h7	M5 x 5 Dp	162	112	8.5	M5 x 6
<b>P5GW-120</b>	12h7	40.0	25.00	83.5	32.0	39.5	25.0	18.0	G1/8 x 8 Dp	6h7	M5 x 5 Dp	205	146	8.5	M5 x 6
<b>P5GW-156</b>	16h7	43.0	25.00	105.0	42.0	51.0	31.0	21.0	G1/8 x 8 Dp	8h7	G1/8 x 8 Dp	258	184	10.3	M5 x 6
<b>P5GW-225</b>	22h7	58.0	34.00	155.0	57.0	69.0	46.0	29.0	G1/8 x 12 Dp	10h7	G1/8 x 8 Dp	355	260	17.5	M8 x 10

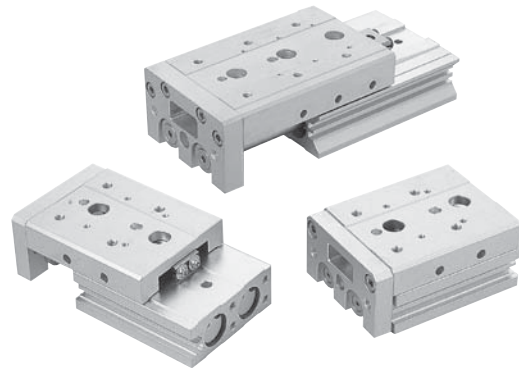
Dimensions in millimeters



For inventory, lead time, and kit lookup, visit [www.pdnplu.com](http://www.pdnplu.com)

Features

- Combination of dual bore cylinder and linear rail
- Magnetic piston standard
- Rubber bumper standard
- Available with stroke adjusters
- Available with shock absorbers



Operating information

Operating pressure: 1.5 to 7 bar (21.8 to 102 PSIG)  
 Temperature range: -5° to 60° C (23° to 140° F)  
 Filtration requirements:  
 Air filtration: 40 micron or better  
 Air lubrication: Not necessary\*  
 Air humidity: Low moisture content (dry)

\*Addition of lubrication will greatly increase service life

Ordering Information: P5SS Slide Tables

<b>P5</b>	<b>S</b>	<b>S</b>	<b>-</b>	<b>***</b>	<b>D</b>	<b>S</b>	<b>G</b>	<b>***</b>	<b>B</b>	<b>N</b>	<b>A</b>	<b>N</b>	<b>N</b>	<b>N</b>														
Family	Series	Spare		Function	Temperature / Finish	Ports	Stroke	Options	Fitting	Spare	Spare	Spare																
S Slide	S Slide table	-		D Double acting magnetic	S Standard	G BSPP	010 10mm 020 20mm 030 30mm 040 40mm 050 50mm 075 75mm 100 100mm 125 125mm 150 150mm	B No options W With specified options pos 16-20	N None	N None	N None	N None																
<table border="1"> <thead> <tr> <th colspan="2">Bore size</th> </tr> </thead> <tbody> <tr> <td>006</td> <td>6mm bore: 10, 20, 30, 40, 50mm stroke</td> </tr> <tr> <td>008</td> <td>8mm bore: 10, 20, 30, 40, 50, 75mm stroke</td> </tr> <tr> <td>012</td> <td>12mm bore: 10, 20, 30, 40, 50, 75, 100mm stroke</td> </tr> <tr> <td>016</td> <td>16mm bore: 10, 20, 30, 40, 50, 75, 100, 125mm stroke</td> </tr> <tr> <td>020</td> <td>20mm bore: 10, 20, 30, 40, 50, 75, 100, 125, 150mm stroke</td> </tr> <tr> <td>025</td> <td>25mm bore: 10, 20, 30, 40, 50, 75, 100, 125, 150mm stroke</td> </tr> </tbody> </table>															Bore size		006	6mm bore: 10, 20, 30, 40, 50mm stroke	008	8mm bore: 10, 20, 30, 40, 50, 75mm stroke	012	12mm bore: 10, 20, 30, 40, 50, 75, 100mm stroke	016	16mm bore: 10, 20, 30, 40, 50, 75, 100, 125mm stroke	020	20mm bore: 10, 20, 30, 40, 50, 75, 100, 125, 150mm stroke	025	25mm bore: 10, 20, 30, 40, 50, 75, 100, 125, 150mm stroke
Bore size																												
006	6mm bore: 10, 20, 30, 40, 50mm stroke																											
008	8mm bore: 10, 20, 30, 40, 50, 75mm stroke																											
012	12mm bore: 10, 20, 30, 40, 50, 75, 100mm stroke																											
016	16mm bore: 10, 20, 30, 40, 50, 75, 100, 125mm stroke																											
020	20mm bore: 10, 20, 30, 40, 50, 75, 100, 125, 150mm stroke																											
025	25mm bore: 10, 20, 30, 40, 50, 75, 100, 125, 150mm stroke																											

Theoretical force



Tube I.D. (mm)	Piston rod (mm)	Operating direction	Piston area (mm²)	Operating pressure MPa						
				0.2	0.3	0.4	0.5	0.6	0.7	
6	3	OUT	57	11	17	23	29	34	40	
		IN	42	8	13	17	21	25	29	
8	4	OUT	101	20	30	40	51	61	71	
		IN	75	15	23	30	38	45	53	
12	6	OUT	226	45	68	90	113	136	158	
		IN	170	34	51	68	85	102	119	
16	8	OUT	402	80	121	161	201	241	281	
		IN	302	60	91	121	151	181	211	
20	10	OUT	628	126	188	251	314	377	400	
		IN	471	94	141	188	236	283	330	
25	12	OUT	982	196	295	393	491	589	687	
		IN	756	151	227	302	378	454	529	

Options	
A	5mm adjuster extension
B	5mm adjuster retraction
C	5mm adjuster both ends
D	15mm adjuster extension
E	15mm adjuster retraction
F	15mm adjuster both ends
G†	25mm adjuster extension
H†	25mm adjuster retraction
J	25mm adjuster both ends
K*	Shock absorber extension
L*	Shock absorber retraction
M*	Shock absorber both ends
N	None

\* Option K, L & M shock absorber is not available on 6mm bore

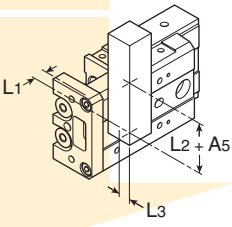
† Option G & H 25mm adjuster is not available on 6mm bore

Sensor part numbers: Page F52.



For inventory, lead times, and kit lookup, visit [www.pdnplu.com](http://www.pdnplu.com)

**Selection Flow Chart**

Operating conditions	Formula and charts	Selection example
List out the operating conditions according to mounting position and shape of the workpiece	Model used Cushion style Workpiece install position Mounting position Average speed $V_a$ (mm/s) Allowable load $W$ (kg) (Figure 1) Overhang $L_n$ (mm) (Figure 2)	Cylinder: P5SS-6-10 Cushion: Cushion pad Workpiece table mounting Mounting: Lateral mounting Average speed: $V_a = 150$ mm/s Load: $W = 0.3$ kg $L_1 = 4$ mm $L_2 = 4$ mm $L_3 = 4$ mm
		
<b>Kinetic energy</b>		
Calculate kinetic energy $E$ (J) of work	$E = 1/2 \cdot W (V/1000)^2$	$E = 1/2 \cdot 0.3 (210/1000)^2 = 0.0066$
	Collision speed $V = 1.4 \cdot V_a$	Collision speed $V = 1.4 \cdot 150 = 210$
Calculate allowable kinetic energy $E_a$ (J)	$E_a = K \cdot E_{max}$	$E_a = 1 \cdot 0.015 = 0.015$
	Workpiece mounting coefficient $K$ : Figure 3	Possible to use by $E = 0.0066 \leq E_a = 0.015$
Make sure that kinetic energy of work is less / lower than allowable kinetic energy.	Max. allowable kinetic energy $E_{max}$ : Table 1 Kinetic energy ( $E$ ) $\leq$ Allowable kinetic energy ( $E_a$ )	
<b>Load rate</b>		
<b>Load rate of work</b>		
Calculate static work $W_a$ (kg)	$W_a = K \cdot \beta \cdot W_{max}$ Workpiece mounting coefficient $K$ : Figure 3 Allowable load coefficient $\beta$ : Figure 4 Maximum allowable moment $W_{max}$ : Table 2	$W_a = 1 \times 1 \times 0.6 = 0.66$ $K = 1$ $\beta = 1$ $W_{max} = 0.6$
Calculate load rate $\alpha_1$ of static work	$\alpha_1 = W/W_a$	$\alpha_1 = 0.3/0.6 = 0.5$
<b>Load rate of static moment</b>		<b>Yawing</b> <b>Rolling</b>
Calculate static moment $M$ (Nm).	$M = W \times 9.8 (L_n + A_n)/1000$ Correction value for moment center distance $A_n$ : Table 3	Calculate $M_y$ Calculate $M_r$
Calculate allowable static moment $M_a$ (Nm).	$M_a = K \cdot \gamma \cdot M_{max}$ Workpiece mounting coefficient $K$ : Figure 3 Allowable moment coefficient $\gamma$ : Figure 5 Max. allowable moment $M_{max}$ : Table 4	$M_y = W \times 9.8 (L_1 + A_3)/1000 = 0.3 \times 9.8 (4 + 13)/1000 = 0.05$ $M_r = W \times 9.8 (L_3 + A_2)/1000 = 0.3 \times 9.8 (5 + 6)/1000 = 0.033$ $A_3 = 13$ $A_2 = 6$ $M_{ay} = 1 \times 1 \times 0.7 = 0.7$ $M_{ar} = 0.7$ (Same value as $M_a$ ) $M_{y_{max}} = 0.7$
Calculate load rate $\alpha_2$ of static moment	$\alpha_2 = M/M_a$	$\alpha_2 = 0.05/0.7 = 0.072$ $\alpha'_2 = 0.033/0.7 = 0.047$
<b>Load rate of kinetic moment</b>		<b>Pitching</b> <b>Yawing</b>
Calculate kinetic moment $M_e$ (Nm).	$M_e = 1/3 \cdot W_e \cdot 9.8 (L_n + A_n)/1000$ Collision equivalence load $W_e = \delta \cdot W \cdot V$ $\delta$ : Cushion coefficient with cushion pad (Standard) = 4/100 with shock absorber = 1/100	Calculate $M_{ep}$ Calculate $M_{ey}$
Calculate allowable kinetic moment $M_{ea}$ (Nm).	Correction value for moment center distance $A_n$ : Table 3 $M_{ea} = K \cdot \gamma \cdot M_{max}$ Workpiece mounting coefficient $K$ : Figure 3 Allowable moment coefficient $\gamma$ : Figure 5 Max. allowable moment $M_{max}$ : Table 4	$M_{ep} = 1/3 \times 2.52 \times 9.8 \times (5 + 6)/1000 = 0.09$ $M_{ey} = 1/3 \times 2.52 \times 9.8 \times (4 + 16)/1000 = 0.165$ $W_e = 4/100 \times 0.3 \times 210 = 2.52$ $W_e = 2.52$ $A_2 = 6$ $A_4 = 16$ $M_{ep} = 1 \times 0.97 \times 0.7 = 0.679$ $M_{ey} = 0.679$ (Same value as $M_{ep}$ ) $K = 1$
Calculate load rate $\alpha_3$ of kinetic moment.	$\alpha_3 = M_e/M_{ea}$	$\alpha_3 = 0.09/0.679 = 0.13$ $\alpha'_3 = 0.165/0.679 = 0.243$
<b>Sum of load rate</b>		
When sum of load rate does not exceed 1, it is possible to use.	$\sum \alpha_n = \alpha_1 + \alpha_2 + \alpha_3 \leq 1$	$\sum \alpha_n = \alpha_1 + \alpha_2 + \alpha'_2 + \alpha_3 + \alpha'_3 \leq 1$ $= 0.5 + 0.072 + 0.047 + 0.133 + 0.243 = 0.995 \leq 1$ And it is possible to use.

**Automation Products**  
**Grippers**  
**Slide Tables**  
**Rotary Tables**  
**Escapements**  
**Sensors & Fittings**



For inventory, lead time, and kit lookup, visit [www.pdnplu.com](http://www.pdnplu.com)

**Table 1: Maximum allowable kinetic energy: Emax (J)**

Allowable kinetic energy		
Cushion pad	Shock absorber	Model
0.015	—	<b>P5SS-006</b>
0.023	0.041	<b>P5SS-008</b>
0.05	0.105	<b>P5SS-012</b>
0.104	0.214	<b>P5SS-016</b>
0.153	0.313	<b>P5SS-020</b>
0.232	0.472	<b>P5SS-025</b>

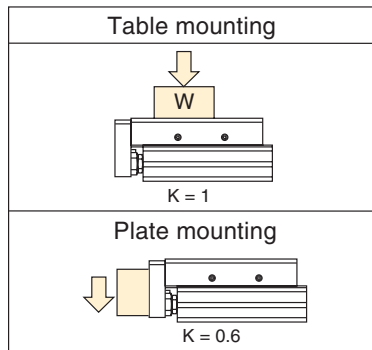
**Table 2: Maximum allowable static load: Wmax (kg)**

Max. allowable kinetic energy	Model
0.6	<b>P5SS-006</b>
0.8	<b>P5SS-008</b>
2	<b>P5SS-012</b>
3.7	<b>P5SS-016</b>
6	<b>P5SS-020</b>
8.5	<b>P5SS-025</b>

**Table 3: Correction value for moment center distance: An (mm) (Refer to Figure 2)**

A1	A2	A3	A4	A5	Model
11	6	13	16	16	<b>P5SS-006</b>
11	8	13	20	20	<b>P5SS-008</b>
24	9.5	26	25	25	<b>P5SS-012</b>
27	10.5	30	31	31	<b>P5SS-016</b>
34	15.5	36	38	38	<b>P5SS-020</b>
42	20.5	44	46	46	<b>P5SS-025</b>

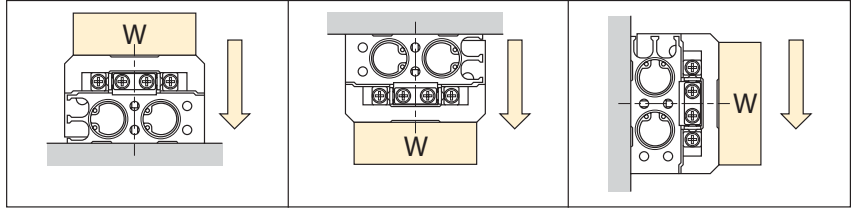
**Figure 3: Workpiece mounting coefficient: K**



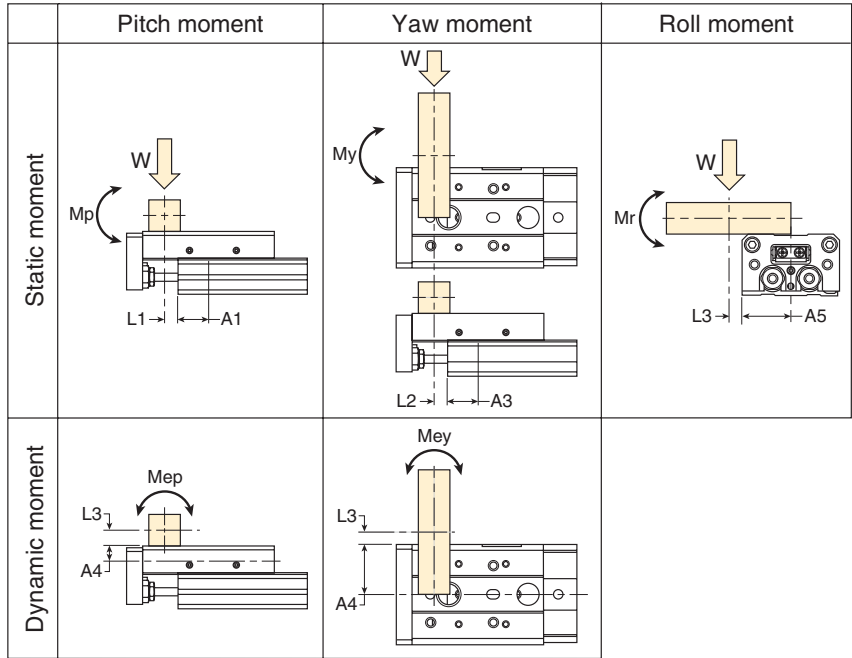
**Table 4: Maximum allowable moment: Mmax (Nm)**

Stroke (mm)									
10	20	30	40	50	75	100	125	150	Model
0.7	1.0	1.1	1.1	1.1	—	—	—	—	<b>P5SS-006</b>
2.0	2.0	2.6	3.5	3.9	3.9	—	—	—	<b>P5SS-008</b>
3.9	3.9	3.9	5.5	6.8	9.6	9.6	—	—	<b>P5SS-012</b>
9.8	9.8	9.8	9.8	12.0	21.0	30.0	30.0	—	<b>P5SS-016</b>
16.4	16.4	16.4	16.4	24.2	31.4	45.5	45.5	45.5	<b>P5SS-020</b>
26.5	26.5	26.5	26.5	37.8	49.8	62.2	62.2	62.2	<b>P5SS-025</b>

**Figure 1: Allowable load: W (kg)**

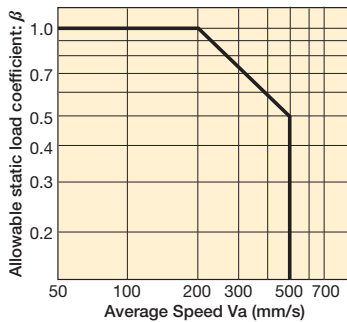


**Figure 2: Overhang: Ln (mm) Correction value for moment center distance: An (mm)**

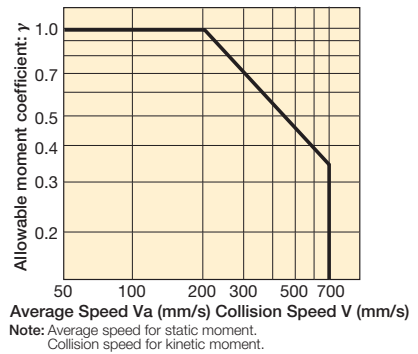


Note: Static moment: Moment by gravity.  
 Kinetic moment: Moment by stopper collision.

**Figure 4: Allowable static load coefficient:  $\beta$**



**Figure 5: Allowable moment coefficient:  $\gamma$**

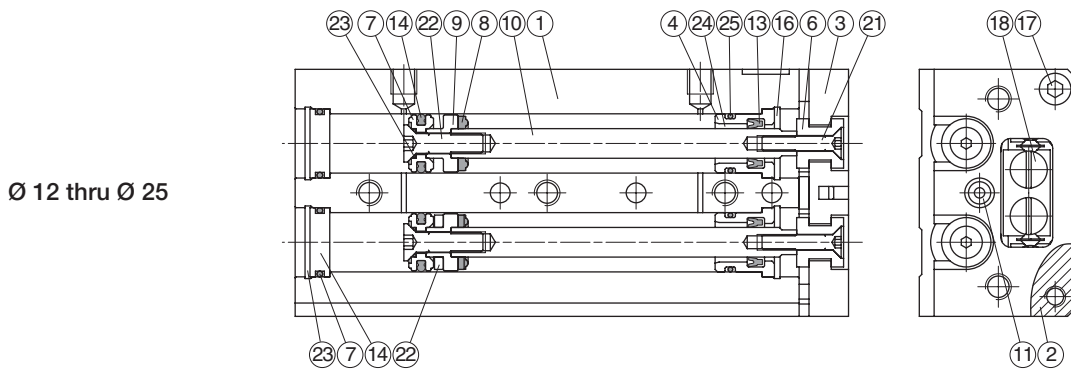
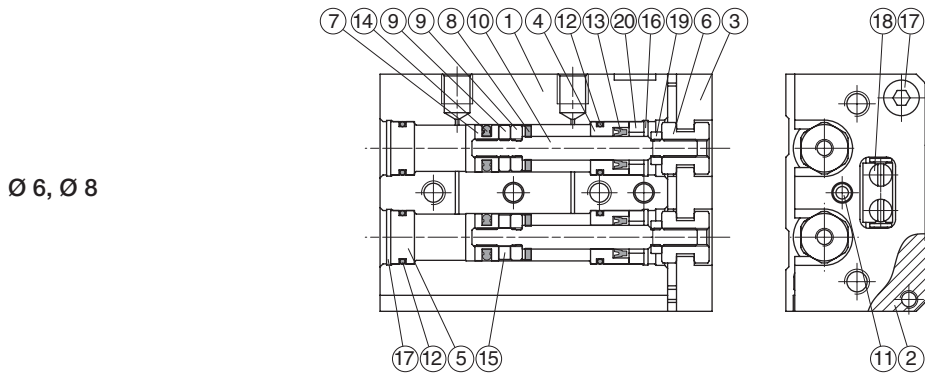


**Automation Products**  
**Grippers**  
**Slide Tables**  
**Rotary Tables**  
**Escapements**  
**Sensors & Fittings**



For inventory, lead times, and kit lookup, visit [www.pdnplu.com](http://www.pdnplu.com)

**Material**



No.	Part name	6	8	12 to 25
1	Body		Aluminum alloy	
2	Table		Aluminum alloy	
3	Plate		Aluminum alloy	
4	Rod cover		Aluminum alloy	
5	Head cover		Aluminum alloy	
6	Floating connector		Stainless steel	
7	Piston	Stainless steel		Aluminum alloy
8	Cushion pad		NBR	
9	Spacer ring	Aluminum alloy	Stainless steel	Aluminum alloy
10	Piston rod		Stainless steel	
11	End cushion		PU	
12	Cover ring		NBR	
13	Rod packing		NBR	

No.	Part name	6	8	12 to 25
14	Piston packing		NBR	
15	Magnet ring		Magnet material	
16	Snap ring	Spring steel		Stainless steel
17	Bolt		Stainless steel	
18	Slide way		Bearing steel	
19	Nut	Copper		—
20	Rod cover washer	Stainless steel		—
21	Floating connector bolt	Stainless steel		—
22	Piston screw		—	Stainless steel
23	Piston gasket		—	NBR
24	Rod bush		Copper	
25	Cover ring		NBR	

**Weight (g)**

Stroke (mm)	Tube I.D.					
	Ø6	Ø8	Ø12	Ø16	Ø20	Ø25
10	78	137	335	536	1001	1573
20	98	148	339	546	1012	1587
30	111	171	343	552	1020	1605
40	147	216	393	630	1098	1735
50	172	255	482	723	1254	1930
75	—	367	684	1030	1690	2553
100	—	—	910	1341	2214	3180
125	—	—	—	1646	2729	4082
150	—	—	—	—	3310	4420



For inventory, lead time, and kit lookup, visit [www.pdnplu.com](http://www.pdnplu.com)

F39

**Parker Hannifin Corporation**  
 Pneumatic Division  
 Richland, Michigan  
[www.parker.com/pneumatics](http://www.parker.com/pneumatics)



Automation Products

Grippers

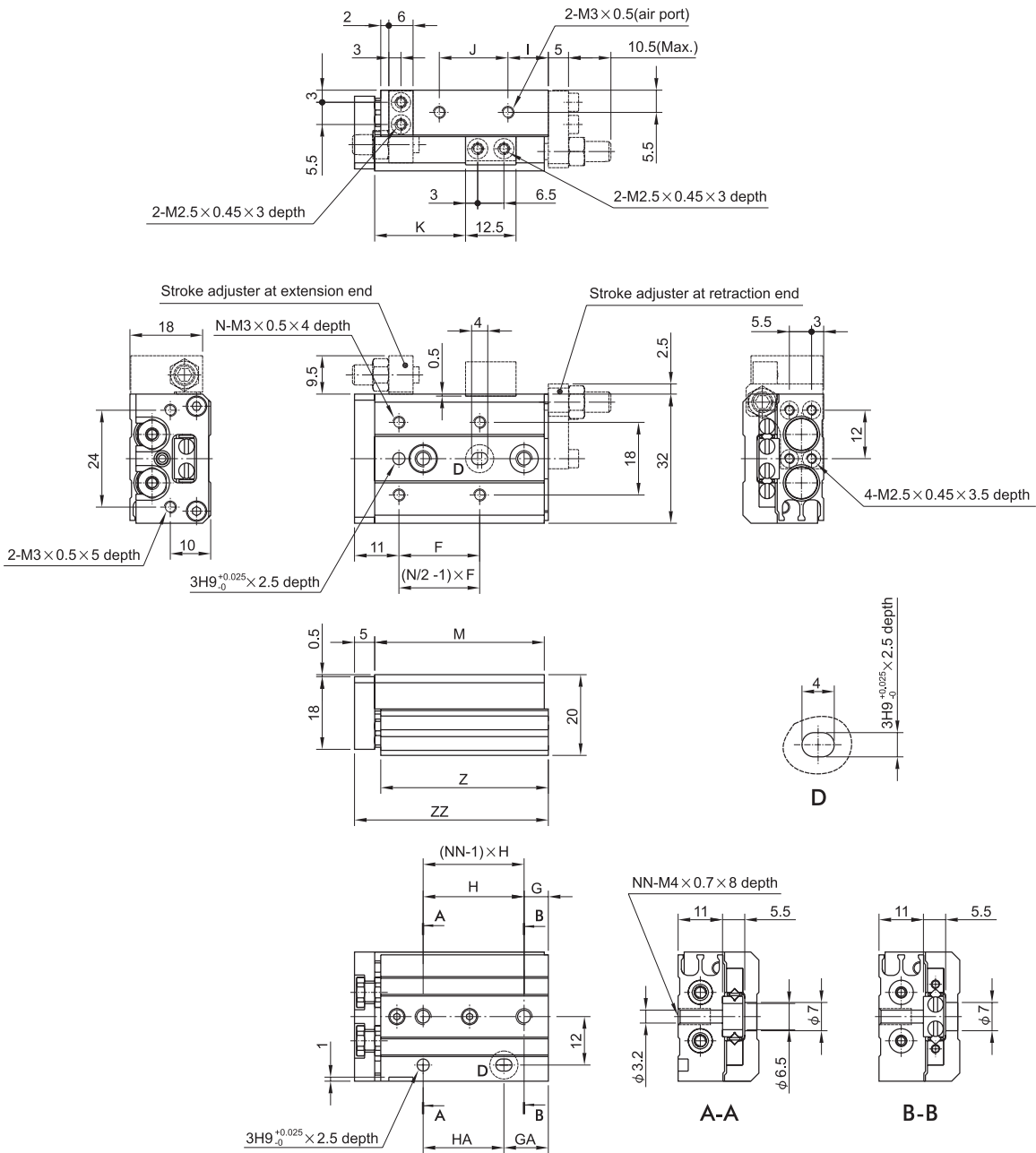
Slide Tables

Rotary Tables

Escapements

Sensors & Fittings

**Dimensions: P5SS Slide Table - Ø 6**



Stroke (mm)	F	G	GA	H	HA	I	J	K	M	N	NN	Z	ZZ
10	20	6	11	25	20	10	17	22.5	42	4	2	41.5	48
20	30	6	21	35	20	10	27	32.5	52	4	2	51.5	58
30	20	11	31	20	20	7	40	42.5	62	6	3	61.5	68
40	28	13	43	30	30	19	50	52.5	84	6	3	83.5	90
50	38	17	41	24	48	25	60	62.5	100	6	4	99.5	106

Dimensions in millimeters

- Automation Products
- Grippers
- Slide Tables
- Rotary Tables
- Escapements
- Sensors & Fittings

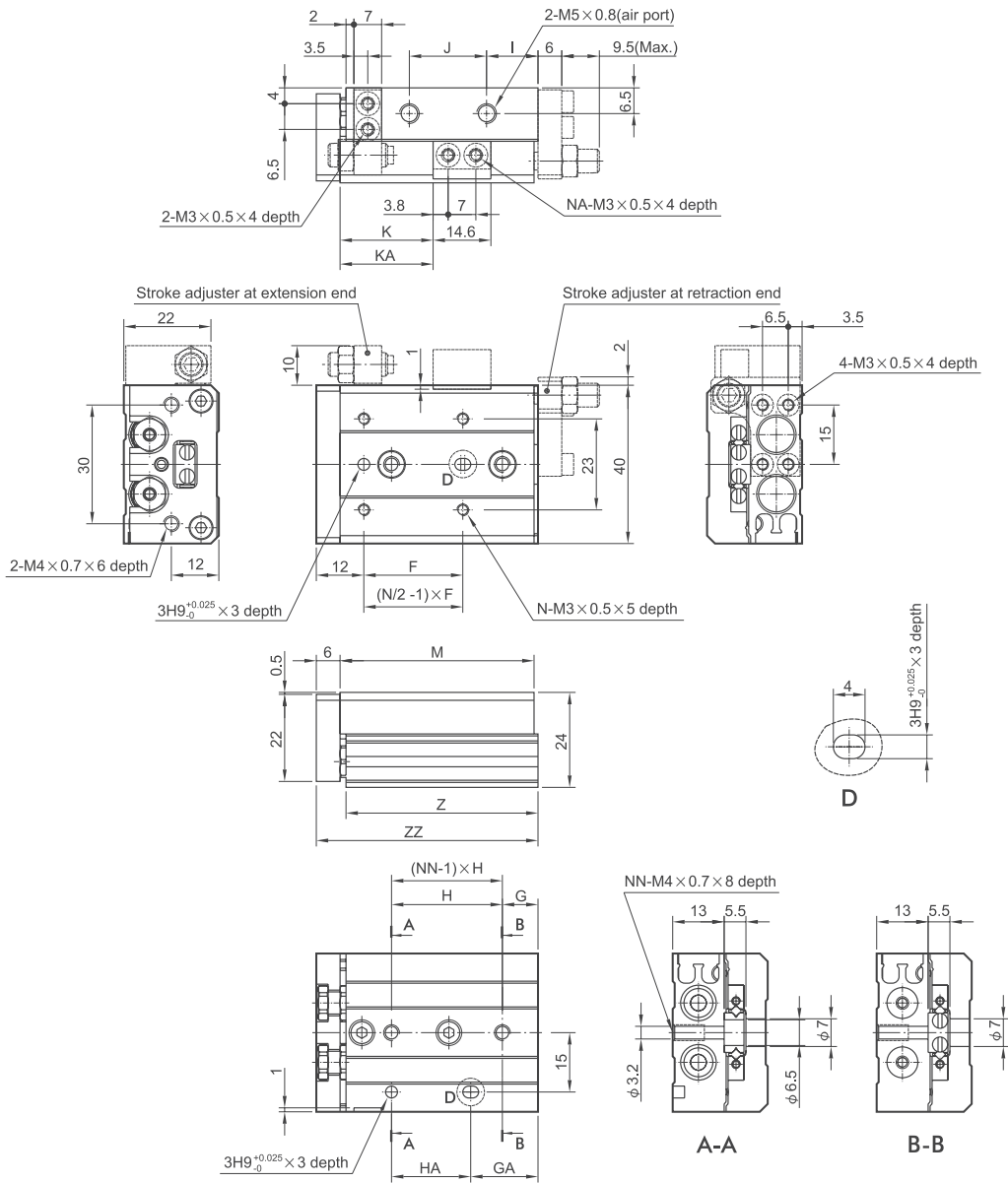


For inventory, lead times, and kit lookup, visit [www.pdnplu.com](http://www.pdnplu.com)

F40

**Parker Hannifin Corporation**  
 Pneumatic Division  
 Richland, Michigan  
[www.parker.com/pneumatics](http://www.parker.com/pneumatics)

**Dimensions: P5SS Slide Table - Ø 8**



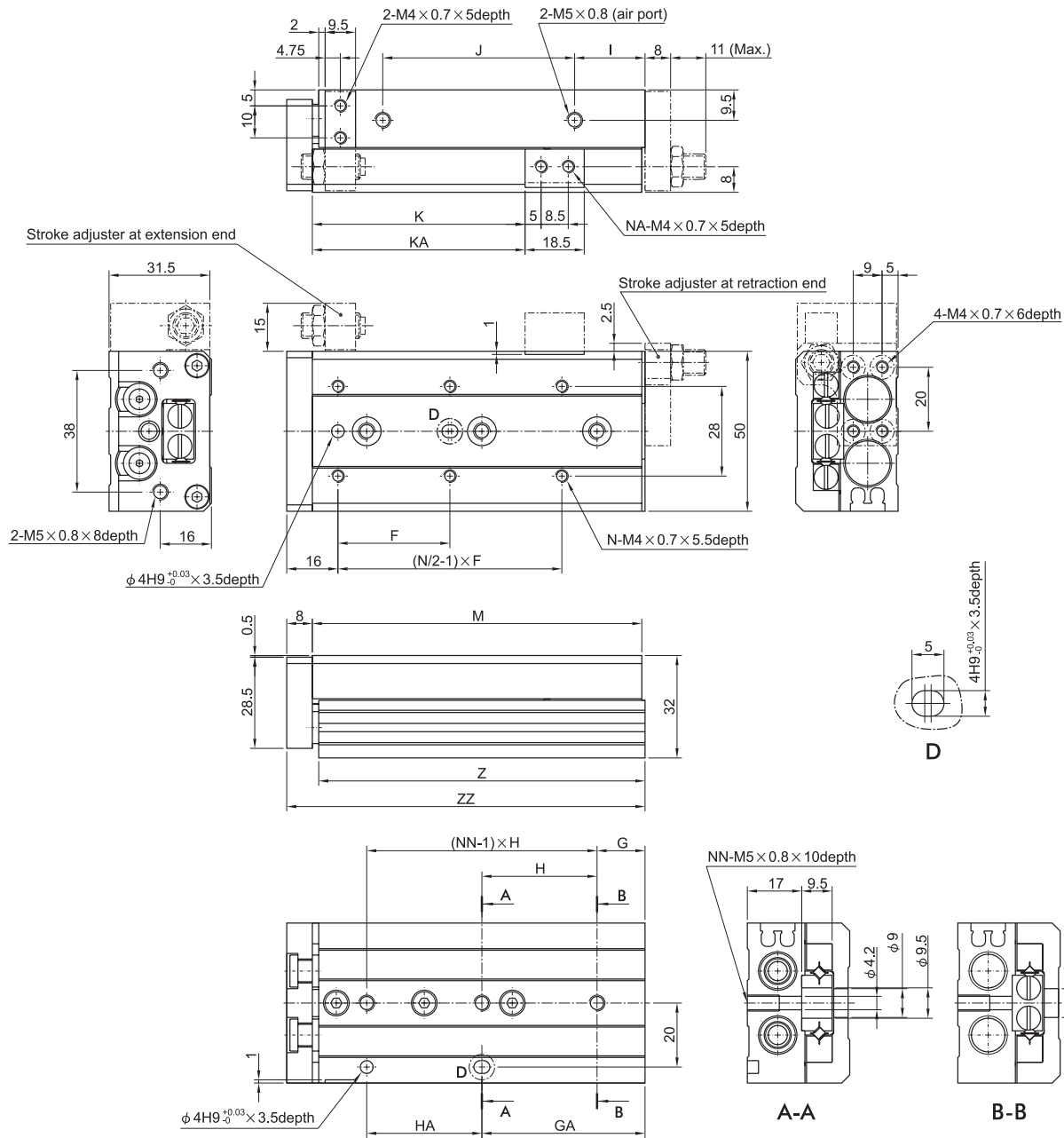
Stroke (mm)	F	G	GA	H	HA	I	J	K	KA	M	N	NA	NN	Z	ZZ
10	25	9	17	28	20	13	19.5	23.5	—	49	4	2	2	48.5	56
20	25	12	12	30	30	8.5	29	33.5	—	54	4	2	2	53.5	61
30	40	13	33	20	20	9.5	39	43.5	—	65	4	2	3	64.5	72
40	50	15	43	28	28	10.5	56	53.5	—	83	4	2	3	82.5	90
50	38	20	43	23	46	24.5	60	63.5	82.5	101	6	4	4	100.5	108
75	50	27	83	28	56	38.5	96	88.5	132.5	151	6	4	5	150.5	158

Dimensions in millimeters



For inventory, lead time, and kit lookup, visit [www.pdnplu.com](http://www.pdnplu.com)

**Dimensions: P5SS Slide Table - Ø 12**



Stroke (mm)	F	G	GA	H	HA	I	J	K	KA	M	N	NA	NN	Z	ZZ
10	35	15	15	40	40	10	40	26.5	—	71	4	2	2	70	80
20	35	15	15	40	40	10	40	36.5	—	71	4	2	2	70	80
30	35	15	15	40	40	10	40	46.5	—	71	4	2	2	70	80
40	50	17	42	25	25	10	52	56.5	—	83	4	2	3	82	92
50	35	15	51	36	36	22	60	66.5	—	103	6	2	3	102	108
75	55	25	61	36	72	43	85	91.5	125.5	149	6	4	4	148	158
100	65	35	111	38	76	52	130	116.5	179.5	203	6	4	5	202	212

Dimensions in millimeters

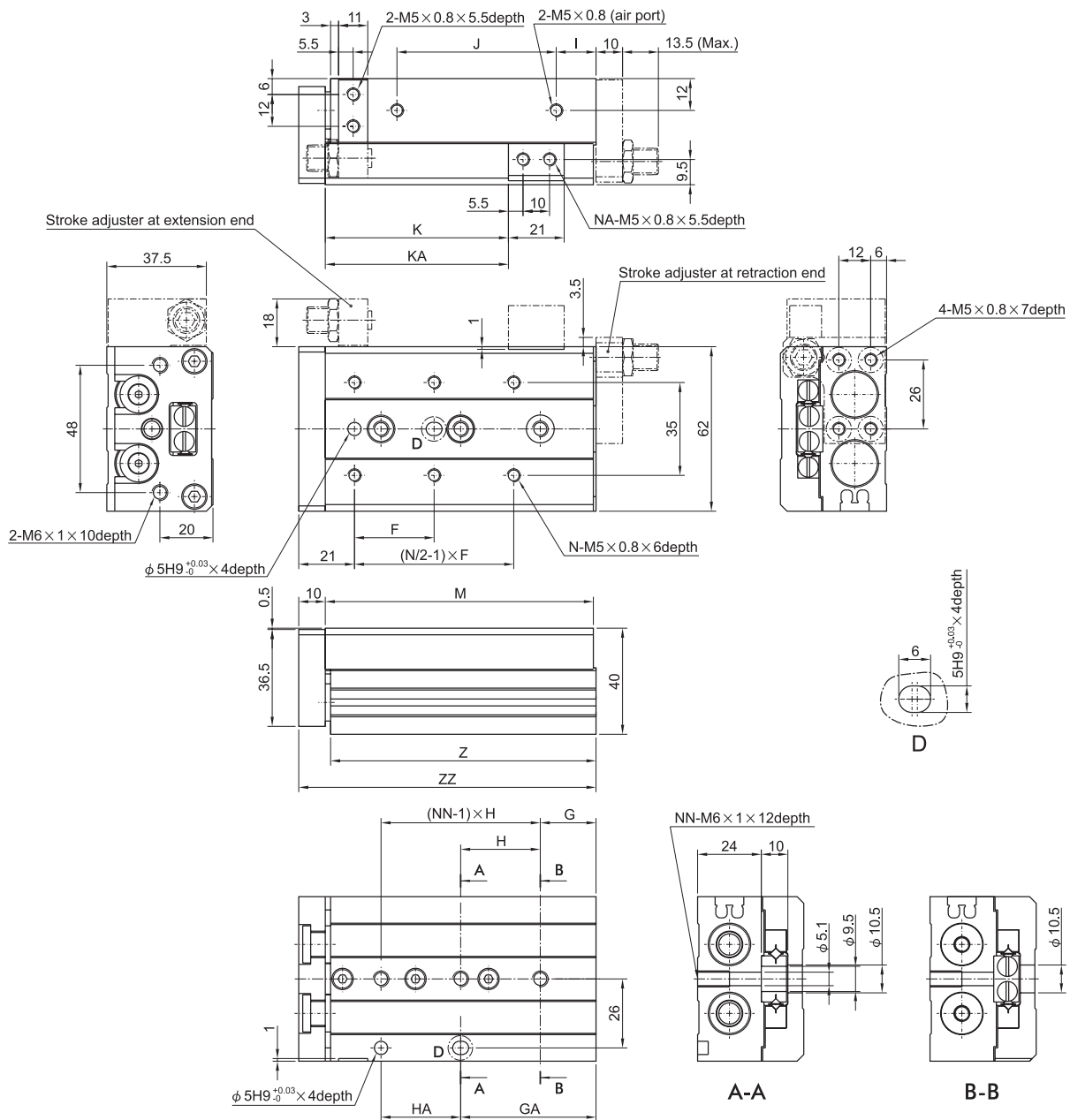


For inventory, lead times, and kit lookup, visit [www.pdnplu.com](http://www.pdnplu.com)

Automation Products  
 Grippers  
 Slide Tables  
 Rotary Tables  
 Escapements  
 Sensors & Fittings



**Dimensions: P5SS Slide Table - Ø 16**



Stroke (mm)	F	G	GA	H	HA	I	J	K	KA	M	N	NA	NN	Z	ZZ
10	35	16	16	40	40	10	40	29	—	76	4	2	2	75	87
20	35	16	16	40	40	10	40	39	—	76	4	2	2	75	87
30	35	16	16	40	40	10	40	49	—	76	4	2	2	75	87
40	40	16	16	50	50	10	50	59	—	86	4	2	2	85	97
50	30	21	51	30	30	15	60	69	—	101	6	2	3	100	112
75	55	26	61	35	70	40	85	94	125	151	6	4	4	150	162
100	65	39	109	35	70	55	118	119	173	199	6	4	5	198	210
125	70	19	159	35	70	68	155	144	223	249	8	4	7	248	260

Dimensions in millimeters

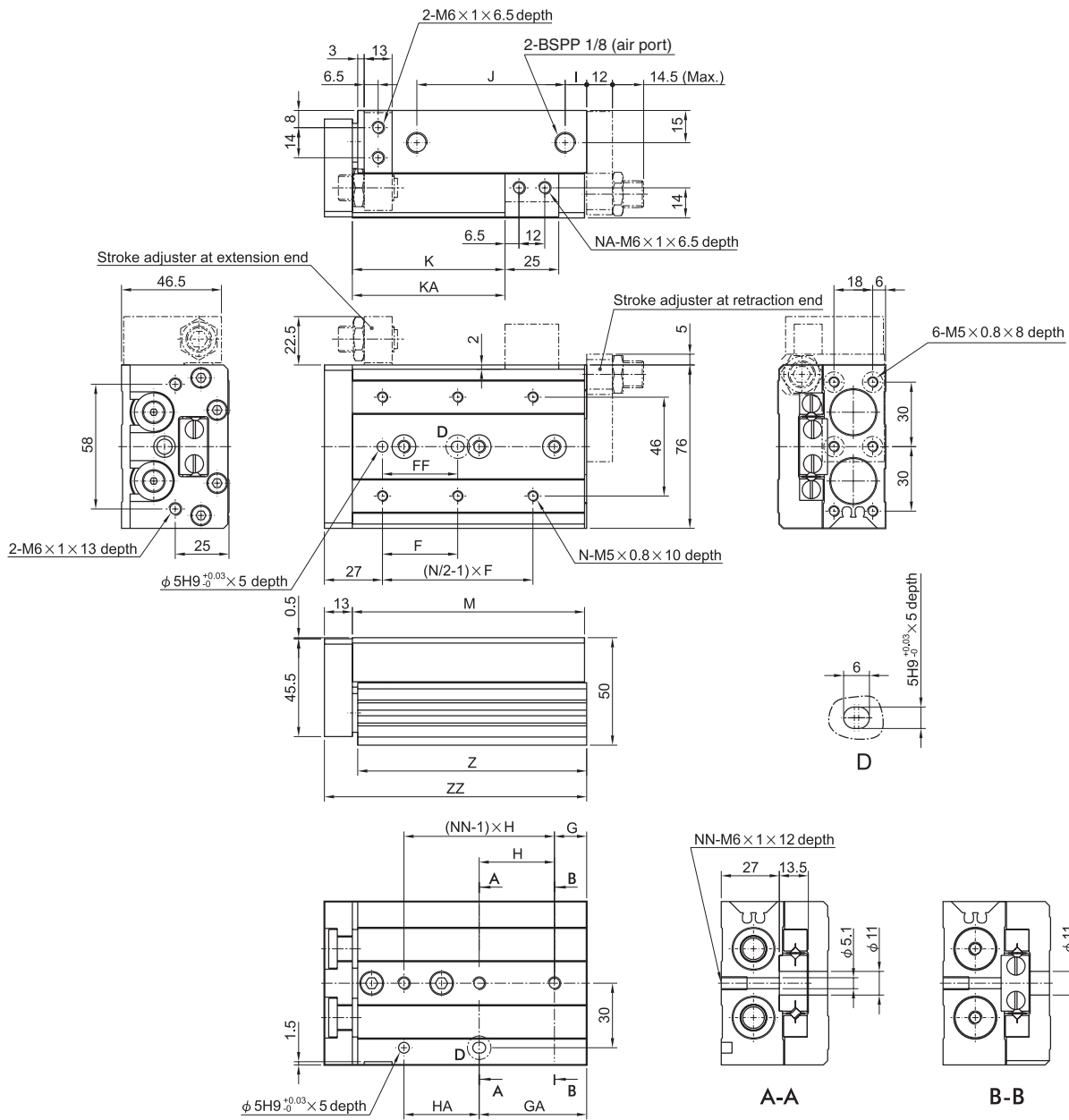


For inventory, lead time, and kit lookup, visit [www.pdnplu.com](http://www.pdnplu.com)

F43

**Parker Hannifin Corporation**  
 Pneumatic Division  
 Richland, Michigan  
[www.parker.com/pneumatics](http://www.parker.com/pneumatics)

**Dimensions: P5SS Slide Table - Ø 20**



Stroke (mm)	F	FF	G	GA	H	HA	I	J	K	KA	M	N	NA	NN	Z	ZZ
10	50	40	15	25	45	35	10	44	31	—	83	4	2	2	81.5	97
20	50	40	15	25	45	35	10	44	41	—	83	4	2	2	81.5	97
30	50	40	15	25	45	35	10	44	51	—	83	4	2	2	81.5	97
40	60	50	15	35	55	35	10	54	61	—	93	4	2	2	91.5	107
50	35	35	15	50	35	36	10	69	71	—	108	6	2	3	106.5	122
75	60	60	19	54	35	70	10	108	96	—	147	6	2	4	145.5	161
100	70	70	37	107	35	70	58	113	121	169	200	6	4	5	198.5	214
125	70	70	41	155	38	76	70	155	146	223	254	8	4	6	252.5	268
150	80	80	19	195	44	88	87	190	171	275	306	8	4	7	304.5	320

Dimensions in millimeters



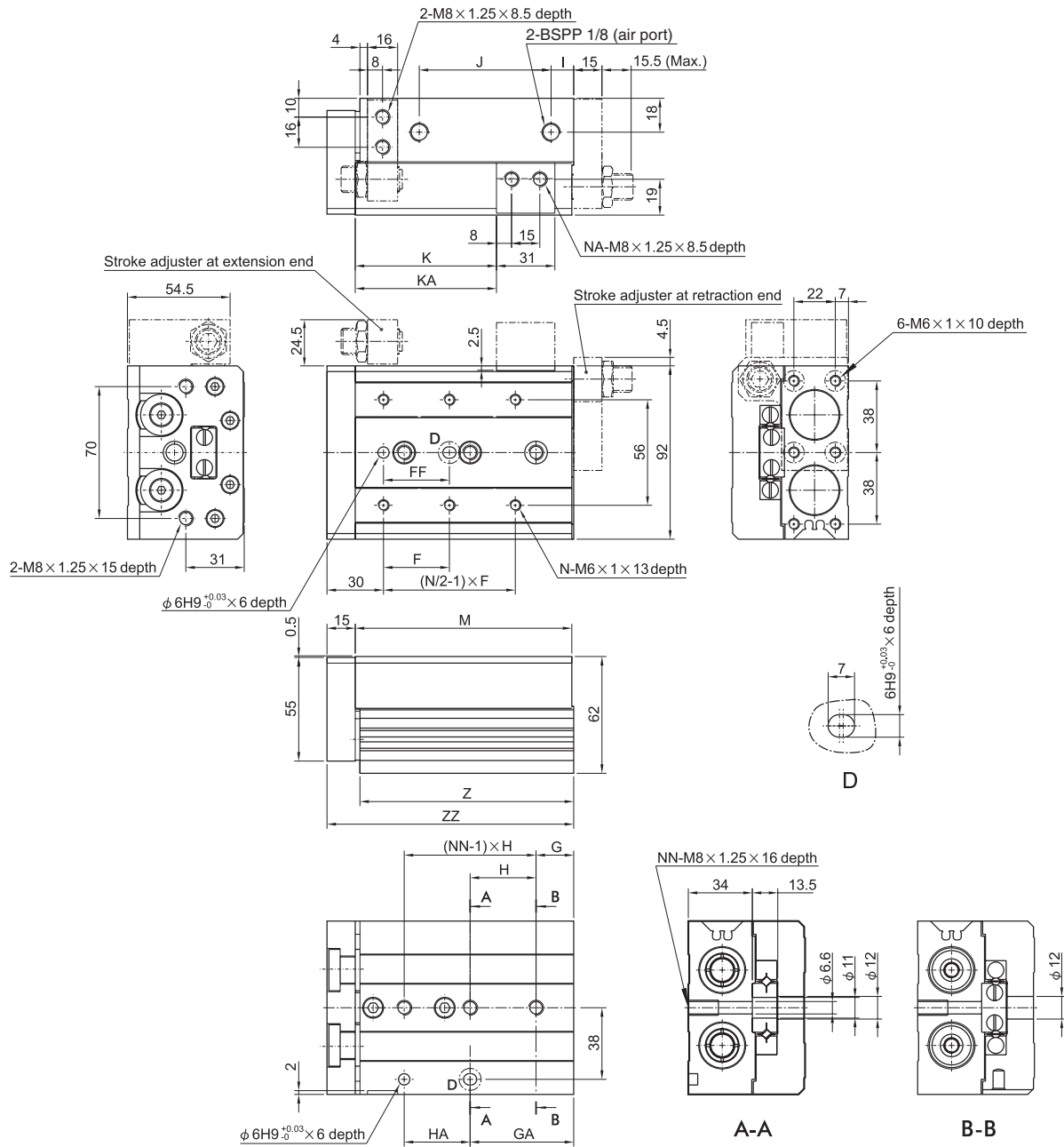
For inventory, lead times, and kit lookup, visit [www.pdnplu.com](http://www.pdnplu.com)

F44

**Parker Hannifin Corporation**  
 Pneumatic Division  
 Richland, Michigan  
[www.parker.com/pneumatics](http://www.parker.com/pneumatics)

Automation Products  
 Grippers  
 Slide Tables  
 Rotary Tables  
 Escapements  
 Sensors & Fittings

**Dimensions: P5SS Slide Table - Ø 25**



Stroke (mm)	F	FF	G	GA	H	HA	I	J	K	KA	M	N	NA	NN	Z	ZZ
10	50	40	22	22	45	45	12	47	35	—	92	4	2	2	90.5	108
20	50	40	22	22	45	45	12	47	45	—	92	4	2	2	90.5	108
30	50	40	22	22	45	45	12	47	55	—	92	4	2	2	90.5	108
40	60	50	22	22	55	55	12	57	65	—	102	4	2	2	100.5	118
50	35	35	20	55	35	35	12	70	75	—	115	6	2	3	113.5	131
75	60	60	26	61	35	70	33	90	100	—	156	6	2	4	154.5	172
100	70	70	32	102	35	70	50	114	125	162	197	6	4	5	195.5	213
125	75	75	40	154	38	76	67	155	150	218	255	8	4	6	253.5	271
150	80	80	30	190	40	80	82	180	175	258	295	8	4	7	293.5	311

Dimensions in millimeters



For inventory, lead time, and kit lookup, visit [www.pdnplu.com](http://www.pdnplu.com)

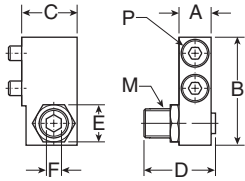
F45

**Parker Hannifin Corporation**  
 Pneumatic Division  
 Richland, Michigan  
[www.parker.com/pneumatics](http://www.parker.com/pneumatics)

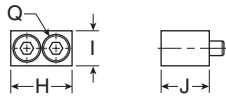
**Stroke Adjusters**

**Stroke Adjuster at Extension End**

**Mounted to Body**



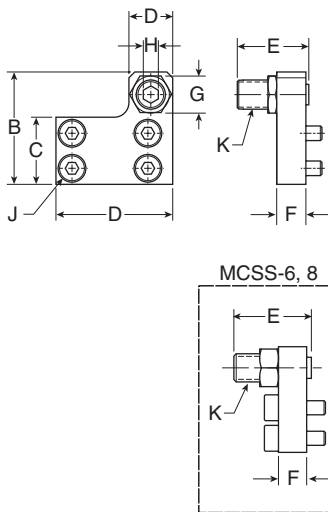
**Mounted to Table**



Tube I.D.	Part number	Adjustable stroke range (mm)	Mounted to body								Mounted to table			
			A	B	C	D	E	F	M	P*	H	I	J	Q*
6	P5SS-006-EA-05	5				16.5	7	2.5	M5 x .08	M2.5 x 10	12.5	6	8.5	M2.5 x .08
	P5SS-006-EA-15	15	6	17.8	10.5	26.5								
8	P5SS-008-EA-05	5				16.5								
	P5SS-008-EA-15	15	7	21.5	11	26.5	8	3	M6 x 1	M3 x 10	14.6	7	10	M3 x 10
	P5SS-008-EA-25	25				36.5								
12	P5SS-012-EA-05	5				20								
	P5SS-012-EA-15	15	9.5	31	16	30	11	4	M8 x 1	M4 x 16	18.5	10	13	M4 x 12
	P5SS-012-EA-25	25				40								
16	P5SS-016-EA-05	5				24.5								
	P5SS-016-EA-10	15	11	37	19	34.5	14	5	M10 x 1	M5 x 16	21	12	16.5	M5 x 16
	P5SS-016-EA-25	25				44.5								
20	P5SS-020-EA-05	5				27.5								
	P5SS-020-EA-15	15	13	45.5	24	37.5	17	6	M12 x 1.25	M6 x 20	25	13	21	M6 x 20
	P5SS-020-EA-25	25				47.5								
25	P5SS-025-EA-05	5				32.5								
	P5SS-025-EA-15	15	16	53.5	26.5	42.5	19	6	M14 x 1.5	M8 x 25	31	17	25.5	M8 x 25
	P5SS-025-EA-25	25				52.5								

\* Size of hexagon socket head cap screws

**Stroke Adjuster at Retraction End**



Tube I.D.	Part number	Adjustable stroke range (mm)	Mounted to table										
			A	B	C	D	E	F	G	H	J*	K	
6	P5SS-006-RA-05	5	21	19	10.5	8	16.5	5	7	2.5	M2.5 x 8	M5 x .08	
	P5SS-006-RA-15	15				26.5							
8	P5SS-008-RA-05	5				16.5							
	P5SS-008-RA-15	15	25	22.5	12.5	9	26.5	6	8	3	M3 x 10	M6 x 1	
	P5SS-008-RA-25	25				36.5							
12	P5SS-012-RA-05	5				20							
	P5SS-012-RA-15	15	32	31	18.5	13	30	8	12	4	M4 x 8	M8 x 1	
	P5SS-012-RA-25	25				40							
16	P5SS-016-RA-05	5				24.5							
	P5SS-016-RA-15	15	40	38.5	12	15	34.5	10	14	5	M5 x 10	M10 x 1	
	P5SS-016-RA-25	25				44.5							
20	P5SS-020-RA-05	5				27.5							
	P5SS-020-RA-15	15	50	48	29	21	37.5	12	17	6	M5 x 12	M12 x 1.25	
	P5SS-020-RA-25	25				47.5							
25	P5SS-025-RA-05	5				32.5							
	P5SS-025-RA-15	15	60	58	35	23	42.5	15	19	6	M6 x 16	M14 x 1.5	
	P5SS-025-RA-25	25				52.5							

\* Size of hexagon socket head cap screws

Dimensions in millimeters

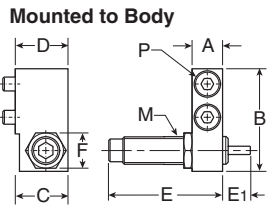


For inventory, lead times, and kit lookup, visit [www.pdnplu.com](http://www.pdnplu.com)

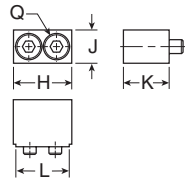
Automation Products  
 Grippers  
 Slide Tables  
 Rotary Tables  
 Escapements  
 Sensors & Fittings

**Shock Absorbers**

**Shock Absorber at Extension End**



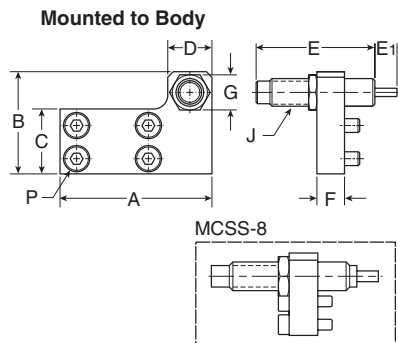
**Mounted to Table**



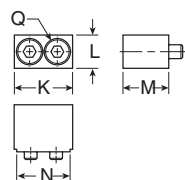
Tube		Mounted to body										Mounted to table				
I.D.	Part number	A	B	C	D	E	E1	F	M	P*	H	J	K	L	Q*	
8	<b>P5SS-008-ESK</b>	7	23	14	15.5	40.8	8	11	M8 x 1	M3 x 16	16.6	7	15.5	14.6	M3 x 16	
12	<b>P5SS-012-ESK</b>	9.5	31	14.5	16	40.8	8	11	M8 x 1	M4 x 16	20.5	10	15	18.5	M4 x 12	
16	<b>P5SS-016-ESK</b>	11	37	17.5	19	43.2	6.6	12.7	M10 x 1	M5 x 16	23	12	18.5	21	M5 x 16	
20	<b>P5SS-020-ESK</b>	13	45.5	23.5	26	86.6	12.7	19	M14 x 1.5	M6 x 25	25.5	13	25.5	25	M6 x 25	
25	<b>P5SS-025-ESK</b>	16	53.5	23.5	26.5	86.6	12.7	19	M14 x 1.5	M8 x 25	25.5	17	25.5	31	M8 x 25	

\*Size of hexagon socket head cap screws

**Shock Absorber at Retraction End**



**Mounted to Table**



Tube		Mounted to body										Mounted to table				
I.D.	Part number	A	B	C	D	E	E1	F	G	M	P*	K	L	M	N	Q*
8	<b>P5SS-008-RSK</b>	38	23	12.5	14	40.8	8	8	12	M8 x 1	M3 x 12	16.6	7	15.5	14.6	M3 x 16
12	<b>P5SS-012-RSK</b>	45	31	18	14	40.8	8	8	11	M8 x 1	M4 x 8	20.5	10	15	18.5	M4 x 12
16	<b>P5SS-016-RSK</b>	55	37	23.5	16	43.2	6.6	10	12.7	M10 x 1	M5 x 10	23	12	18.5	21	M5 x 16
20	<b>P5SS-020-RSK</b>	70	47	29	23	86.6	12.7	12	19	M14 x 1.5	M5 x 12	25.5	13	25.5	25	M6 x 25
25	<b>P5SS-025-RSK</b>	80	54	35	23	86.6	12.7	15	19	M14 x 1.5	M6 x 16	25.5	17	25.5	31	M8 x 25

\*Size of hexagon socket head cap screws

Dimensions in millimeters

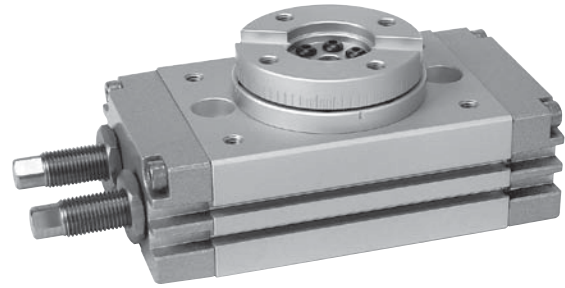


For inventory, lead time, and kit lookup, visit [www.pdnplu.com](http://www.pdnplu.com)

**Features**

**P5RS Rotary Tables**

- Twin rack and pinion
- Adjustable between 0° and 190°
- Magnetic piston standard
- Stroke adjusters standard
- Available with shock absorbers



**Operating information**

Operating pressure:	1 to 9 bar (14.5 to 130.5 PSIG)
Temperature range:	-5° to 60° C (23° to 140° F)
Filtration requirements:	
Air filtration	40 micron or better
Air lubrication	Not necessary*
Air humidity	Low moisture content (dry)
*Addition of lubrication will greatly increase service life	

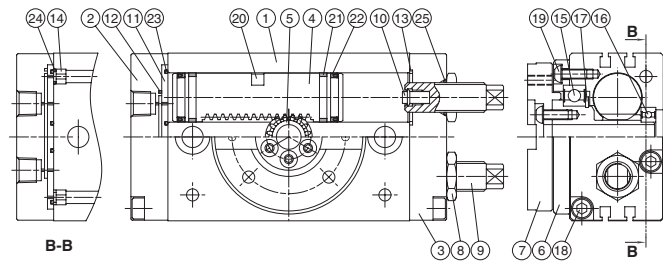
**Ordering Information: P5RS Rotary Tables**

Description	Ports (BSPP)	Rotation	Torque (N-m at 7 bar)	Weight (kg)	Part number
Rotary table, stroke adjusters	1/8	190 degrees	1.69	0.7	<b>P5RS-016DSG190B</b>
Rotary table, stroke adjusters	1/8	190 degrees	3.52	1.16	<b>P5RS-020DSG190B</b>
Rotary table, stroke adjusters	1/8	190 degrees	6.87	1.57	<b>P5RS-025DSG190B</b>
Rotary table, stroke adjusters	1/8	190 degrees	13.52	3.07	<b>P5RS-032DSG190B</b>
Rotary table, shock absorber	1/8	190 degrees	1.69	0.7	N/A
Rotary table, shock absorber	1/8	190 degrees	3.52	1.16	N/A
Rotary table, shock absorber	1/8	190 degrees	6.87	1.57	<b>P5RS-025DSG190WNSNNN</b>
Rotary table, shock absorber	1/8	190 degrees	13.52	3.07	<b>P5RS-032DSG190WNSNNN</b>

Sensor part numbers: Page F52.

**Material**

No.	Part name	Material	No.	Part name	Material
1	Body	Aluminum alloy	14	Fixed	Copper
2	Cover	Aluminum alloy	15	Ball bearing	Bearing steel
3	End cover	Aluminum alloy	16	Ball bearing	Bearing steel
4	Piston	Stainless steel	17	Snap ring	Spring steel
5	Pinion	SCM	18	Screw	SCM
6	Bearing retainer	Aluminum alloy	19	Screw	SCM
7	Table	Aluminum alloy	20	Magnet	Magnet material
8	Seal nut	Stainless steel	21	Wearing	PTFE
9	Shock absorber	Stainless steel	22	Piston packing	NBR
10	Cushion pad	NBR	23	O-ring	NBR
11	Plate	Aluminum alloy	24	O-ring	NBR
12	Packing	NBR	25	O-ring	NBR
13	Gasket	NBR			



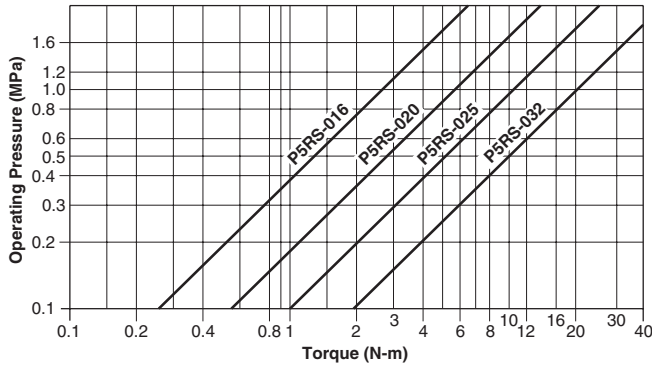
Most popular.



For inventory, lead times, and kit lookup, visit [www.pdnplu.com](http://www.pdnplu.com)

Automation Products  
 Grippers  
 Slide Tables  
 Rotary Tables  
 Escapements  
 Sensors & Fittings

**Load capacity - P5RS Rotary Table**

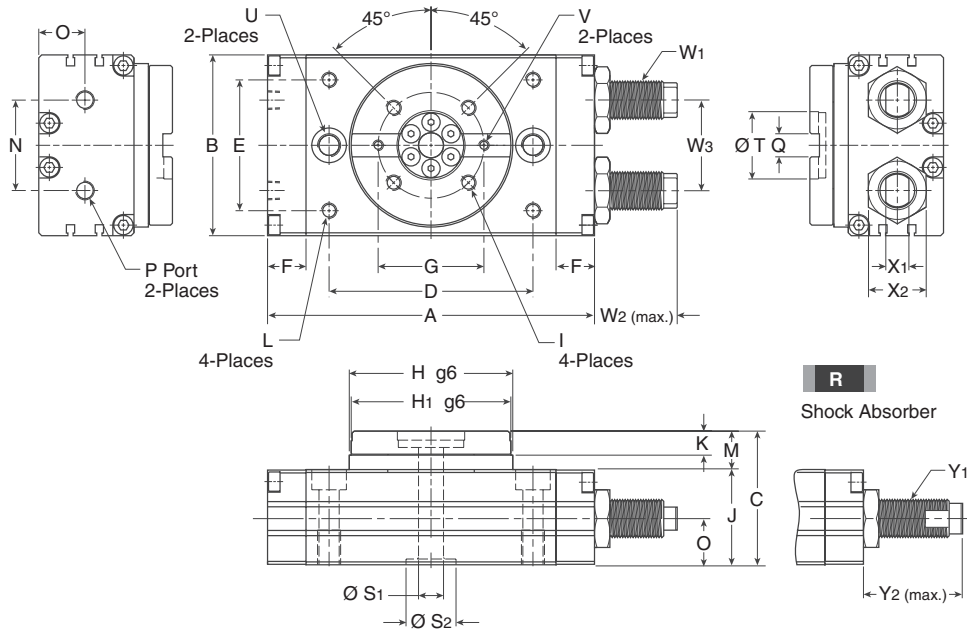


**Allowable load**

Set the load and moment to be applied to the table within the allowable values shown in the table below. (Values outside of limitations will cause excessive play, deteriorate accuracy, and shorten service life)

Bore	Allowable radial load (N)	Allowable thrust load (N)		Allowable moment (Nm)
		(a)	(b)	
16	78	74	78	2.4
20	147	137	137	4.0
25	196	197	363	5.3
32	314	296	451	9.7

**Dimensions: P5RS Rotary Tables**



Tube I.D.	A	B	C	D	E	F	G	H	H <sub>1</sub>	I	J	K	L	M	N	O	P	Q
16	108	58	47	62	38	15	38	50	48	M5 x 7 Dp, P.C.D38	33	8	M5 x 8 Dp	14	26	15.5	BSPP 1/8	8 <sup>+0.03</sup> <sub>0</sub> (wide) x 3.3 Dp
20	128	68	55	78	47	15	46	62.5	60	M6 x 7 Dp, P.C.D46	38	10	M6 x 8 Dp	17	27	18.5	BSPP 1/8	10 <sup>+0.03</sup> <sub>0</sub> (wide) x 3.5 Dp
25	135.5	77	58.5	84	55	15.5	48	67	65	M6 x 9 Dp, P.C.D48	41.5	10	M6 x 8 Dp	17	37	20	BSPP 1/8	12 <sup>+0.03</sup> <sub>0</sub> (wide) x 4 Dp
32	170	94	69.5	106	68	20	55	85	83	M8 x 10 Dp, P.C.D55	49.5	12.5	M8 x 8.5 Dp	20	47	24	BSPP 1/8	12 <sup>+0.03</sup> <sub>0</sub> (wide) x 5 Dp

Tube I.D.	S <sub>1</sub>	S <sub>2</sub>	T	U	V	W <sub>1</sub>	W <sub>2</sub>	W <sub>3</sub>	X <sub>1</sub>	X <sub>2</sub>	Y <sub>1</sub>	Y <sub>2</sub>
16	6	17 (H7) x 2.5 Dp	24 (H7) x 3 Dp	2-Ø 6.8 thru, Ø 11 x 6.5 Dp, M8 x 12 Dp (Sink)	M3 x 4 Dp	M10 x 1.0	27	26	7	17	N/A	31
20	10	22 (H7) x 2.5 Dp	32 (H7) x 3 Dp	2-Ø 8.6 thru, Ø 14 x 8.5 Dp, M10 x 15 Dp (Sink)	M4 x 6 Dp	M12 x 1.0	23	32	8	19	N/A	36
25	13	22 (H7) x 3 Dp	32 (H7) x 3.7 Dp	2-Ø 8.6 thru, Ø 14 x 8.5 Dp, M10 x 15 Dp (Sink)	M4 x 8 Dp	M14 x 1.5	36	37	8	22	MC150M-NB	52
32	13	26 (H7) x 3 Dp	35 (H7) x 4.7 Dp	2-Ø 10.5 thru, Ø 18 x 10.5 Dp, M12 x 18 Dp (Sink)	M5 x 8.5 Dp	M20 x 1.5	43	47	12	30	MC225M-NB	62

Dimensions in millimeters

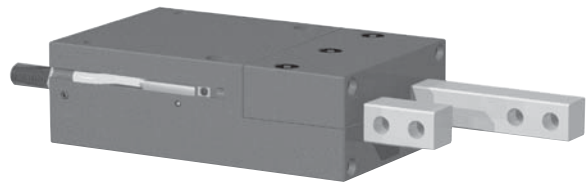


For inventory, lead time, and kit lookup, visit [www.pdnplu.com](http://www.pdnplu.com)

**Features**

**P5MD Feed Escapements**

- Most effective mechanism for separating parts fed from a track or conveyor
- 7075-T6 aircraft quality aluminum body hard-coat anodized 60 RC with PTFE impregnation
- Adjustable retract stops
- Built-in sensor mounting slots
- Built-in sensor magnet for use with Hall Effect sensors
- Sealed design repels contaminants
- Slip fit dowel holes in body for precision applications
- Dynamic components are precision ground and hardened for wear resistance and long life
- Locking key ensures part separation and eliminates jams



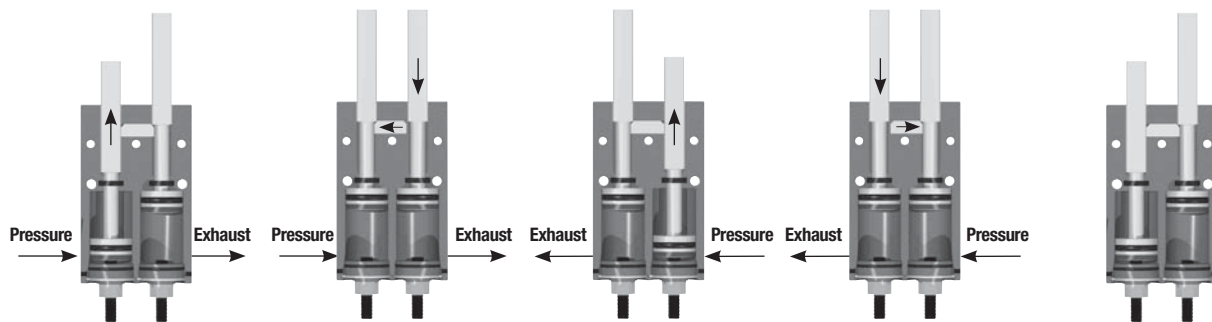
**Operating information**

Operating pressure:	3 to 7 bar (44 to 102 PSIG)
Temperature range:	
Nitrile seals (Standard)	-35° to 80° C (-30° to 180° F)
Filtration requirements:	
Air filtration	40 micron or better
Air lubrication	Not necessary*
Air humidity	Low moisture content (dry)
*Addition of lubrication will greatly increase service life	

**Ordering Information: P5MD Feed Escapements**

Stroke (mm)	Thrust force @ 7 Bar (N)	Parts escaped per minute	Weight (kg)	Side finger mount	Top finger mount
15.9	111	150	0.15	<b>P5MD-014SSG016B</b>	<b>P5MD-014TSG016B</b>
25.4	222	100	0.39	<b>P5MD-020SSG025B</b>	<b>P5MD-020TSG025B</b>
31.8	400	85	0.83	<b>P5MD-027SSG032B</b>	<b>P5MD-027TSG032B</b>

Sensor part numbers: Page F52.



- Dual double acting pistons slide in opposite directions within the body through the use of internal porting.
- When pressure is applied, one piston extends and passes a port in its cylinder wall which is linked to the retract side of the other piston's cylinder.
- The second piston then begins to retract and pushes the locking key aside into the cavity on the side of the first finger.
- Locking Key ensures only 1 finger can be retracted at a time.
- Finger must be allowed to fully extend for proper operation.

☐ Most popular.

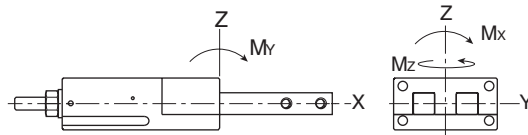


For inventory, lead times, and kit lookup, visit [www.pdnplu.com](http://www.pdnplu.com)

Automation Products  
 Grippers  
 Slide Tables  
 Rotary Tables  
 Escapements  
 Sensors & Fittings

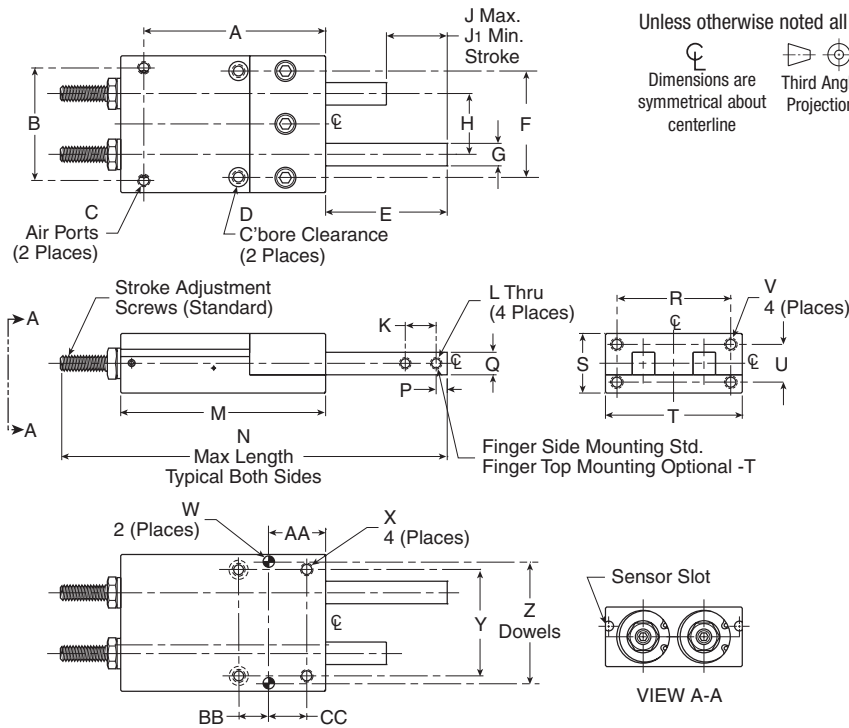


**Loading capacity - P5MD Feed Escapements**



	P5MD-014		P5MD-020		P5MD-027	
	Static (metric)	Dynamic (metric)	Static (metric)	Dynamic (metric)	Static (metric)	Dynamic (metric)
Maximum moment Mx	6 Nm	0.57 Nm	17 Nm	1.70 Nm	28 Nm	2.83 Nm
Maximum moment My	6 Nm	0.57 Nm	17 Nm	1.70 Nm	28 Nm	2.83 Nm
Maximum moment Mz	6 Nm	0.57 Nm	17 Nm	1.70 Nm	28 Nm	2.83 Nm

**Dimensions: P5MD Feed Escapements**



Unless otherwise noted all tolerances are as shown below

Dimensions are symmetrical about centerline  
 Third Angle Projection

**Metric (mm)**  
 (0.) = (±.25)  
 (0.0) = (±.13)  
 (0.00) = (±.013)

Part number	A	B	C	D	E	F	G	H	J	J <sub>1</sub>	K	L	M	N	P	Q	R	S	T
<b>P5MD-014</b>	51	30	M5	Ø 5.64 x 3.2 Dp	41.3	38.1	7.9	15.9	15.9	4.8	12.7	M4	57.9	117	4.8	7.9	38.1	19.1	31.8
<b>P5MD-020</b>	76	47	M5	Ø 7.95 x 1.6 Dp	50.8	44.5	9.5	25.4	25.4	6.4	12.7	M5	85.5	162	4.8	9.5	47.6	24.9	57.2
<b>P5MD-027</b>	100	57.1	M5	Ø 8.9 x 5 Dp	57.2	57.1	12.7	31.8	31.8	12.7	12.7	M6	112.3	197	6.4	12.7	60.3	34.5	69.9

Part number	U	V	W	X	Y	Z	AA	BB	CC
<b>P5MD-014</b>	12.7	M4 x 5.5 Dp	Ø 3 H7 x 3.8 Dp	M4 x 5 Dp	31.8	31.75	15.1	9.5	9.5
<b>P5MD-020</b>	15.9	M5 x 10 Dp	Ø 5 H7 x 5 Dp	M5 x 7 Dp	44.5	50.80	23.8	12.7	15.9
<b>P5MD-027</b>	25.4	M6 x 10 Dp	Ø 5 H7 x 6 Dp	M6 x 11 Dp	57.1	57.15	31.0	19.0	19.0

Dimensions in millimeters



For inventory, lead time, and kit lookup, visit [www.pdnplu.com](http://www.pdnplu.com)

## Sensors

### Magnetic

Series	PNP with quick disconnect M8	NPN with quick disconnect M8	PNP with quick disconnect (90 degrees) M8	NPN with quick Disconnect (90 Degrees) M8	Page
P5GM	<b>P8S-HHSP-017</b>	<b>P8S-HHSN-017</b>	<b>P8S-HHSP-011</b>	<b>P8S-HISN-011</b>	F19
P5GN	<b>P8S-HHSP-017</b>	<b>P8S-HHSN-017</b>	<b>P8S-HHSP-011</b>	<b>P8S-HISN-011</b>	F16
P5GP	<b>P8S-HHSP-017</b>	<b>P8S-HHSN-017</b>	NA	NA	F28
P5GQ	<b>P8S-HHSP-017</b>	<b>P8S-HHSN-017</b>	NA	NA	F30
P5GR	<b>P8S-HHSP-017</b>	<b>P8S-HHSN-017</b>	<b>P8S-HHSP-011</b>	<b>P8S-HISN-011</b>	F22
P5GS	<b>P8S-HHSP-017</b>	<b>P8S-HHSN-017</b>	<b>P8S-HHSP-011</b>	<b>P8S-HISN-011</b>	F19
P5GT	NA	NA	NA	NA	F25
P5GU	<b>P8S-HHSP-017</b>	<b>P8S-HHSN-017</b>	NA	NA	F13
P5GV	NA	NA	NA	NA	F8
P5GW	<b>P8S-HHSP-017</b>	<b>P8S-HHSN-017</b>	<b>P8S-HHSP-011</b>	<b>P8S-HISN-011</b>	F28
P5MD	<b>P8S-HHSP-017</b>	<b>P8S-HHSN-017</b>	NA	NA	F50

### Inductive

Series	PNP M8 disconnect	NPN M8 disconnect	PNP M12 disconnect	NPN M12 disconnect	Inductive sensor mounting kit	Page
P5GR-010	<b>P8S-HISP-014</b>	<b>P8S-HISN-014</b>	NA	NA	<b>P8S-HSMK-119</b>	F10
P5GR-014					<b>P8S-HSMK-119</b>	F10
P5GR-021					<b>P8S-HSMK-120</b>	F10
P5GS-016	<b>P8S-HISP-019</b>	<b>P8S-HISN-019</b>	NA	NA	<b>P8S-HSMK-116</b>	F22
P5GS-024					<b>P8S-HSMK-117</b>	F22
P5GS-032					<b>P8S-HSMK-118</b>	F22
P5GT-025	<b>P8S-HISP-019</b>	<b>P8S-HISN-019</b>	NA	NA	<b>P8S-HSMK-003</b>	F25
P5GT-025					<b>P8S-HSMK-003</b>	F25
P5GT-032					<b>P8S-HSMK-003</b>	F25
P5GT-046	<b>P8S-HISP-011</b>	<b>P8S-HISN-011</b>	NA	NA	<b>P8S-HSMK-072</b>	F25
P5GT-064					<b>P8S-HSMK-072</b>	F25
P5GT-089					<b>P8S-HSMK-073</b>	F25
P5GW-072	<b>P8S-HISP-011</b>	<b>P8S-HISN-011</b>	NA	NA	NA	F25
P5GW-95					NA	F32
P5GW-120					NA	F32
P5GW-156	NA	NA	<b>P8S-HISN-017</b>	<b>P8S-HISP-017</b>	NA	F32
P5GW-220					NA	F32

### Sensors for Economy Grippers, Slide Tables, Rotary Tables

Series	Reed switch 5-120V AC/DC	Reed switch 5-120V AC/DC M8	NPN 5-30 VDC	NPN 5-30VDC M8	PNP 5-30 VDC	PNP 5-30VDC M8	Page
P5SS	<b>P8S-ERFXS</b>	<b>P8S-ERSUS</b>	<b>P8S-ENFXS</b>	<b>P8S-ENSUS</b>	<b>P8S-EPFXS</b>	<b>P8S-EPSUS</b>	F36
P5GA	<b>P8S-ERFXS</b>	<b>P8S-ERSUS</b>	<b>P8S-ENFXS</b>	<b>P8S-ENSUS</b>	<b>P8S-EPFXS</b>	<b>P8S-EPSUS</b>	F4
P5GB	<b>P8S-ERFXS</b>	<b>P8S-ERSUS</b>	<b>P8S-ENFXS</b>	<b>P8S-ENSUS</b>	<b>P8S-EPFXS</b>	<b>P8S-EPSUS</b>	F6
P5RS	<b>P8S-FRFXS</b>	<b>P8S-FRSUS</b>	<b>P8S-FNFXS</b>	<b>P8S-FNSUS</b>	<b>P8S-FPFXS</b>	<b>P8S-FPSUS</b>	F48

### Cables

2 meter cable M8	5 meter cable M8	2 meter cable M12	5 meter cable M12
<b>P8S-CABL-010</b>	<b>P8S-CABL-013</b>	<b>P8S-CABL-014</b>	<b>P8S-CABL-018</b>



For inventory, lead times, and kit lookup, visit [www.pdnplu.com](http://www.pdnplu.com)

Automation Products  
 Grippers  
 Slide Tables  
 Rotary Tables  
 Escapements  
 Sensors & Fittings

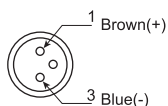
# Technical Data

Model	P8S-FRFXS P8S-FRSUS (M8)	P8S-FNFXS	P8S-FPFXS
Wiring method	2 wire	3 wire	
Switching logic	SPST normally open	Solid state output, normally open	
Switch type	Reed switch	NPN current sinking	PNP current sourcing
Operating voltage	5 to 120 V DC/AC	5 to 30 VDC	
Switching voltage	100 mA max.	200 mA max.	
Contact rating	10 W max.	6 W max.	
Current consumption	—	8 mA @ 24 V max. (Switch active)	
Voltage drop	3.5 V max.	1 V @ 200 mA max.	
Leakage current	—	0.01 mA max.	
Indicator	Red LED	Red LED	Green LED
Cable	2.8 Ø, 2C	2.8 Ø, 3C	
Magnet frequency <sup>(1)</sup>	60 Gauss	40 Gauss	
Temperature range	-10°C to 70°C (14°F to 158°F)		
Shock <sup>(2)</sup>	30 G	50 G	
Vibration <sup>(3)</sup>	9 G		
Enclosure classification	IEC 529, IP67		
Protection circuit	None	Power source reverse polarity; surge suppression	
Connect diagram			

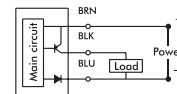
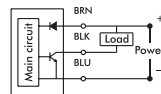
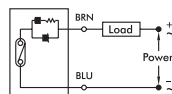
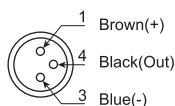
- (1) Measuring standard target: Ø 15.5 x Ø 8 x 5t (Anisotropy rubber magnet).
- (2) Sine wave / X.Y.Z 3 directions / 3 times each direction / 11ms each time.
- (3) Double amplitude 1.5 mm / 10 Hz -55 Hz-10 Hz (Sweep 1min / X.Y.Z. 3 directions / 1 hour each time.

## Wiring of the QD

2 wire QD wiring



3 wire QD wiring



For inventory, lead time, and kit lookup, visit [www.pdnplu.com](http://www.pdnplu.com)

F53

[www.comoso.com](http://www.comoso.com)

**Parker Hannifin Corporation**  
Pneumatic Division  
Richland, Michigan  
[www.parker.com/pneumatics](http://www.parker.com/pneumatics)



Automation  
Products

Grippers

Slide  
Tables

Rotary  
Tables

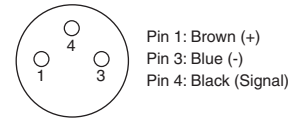
Escapements

Sensors &  
Fittings

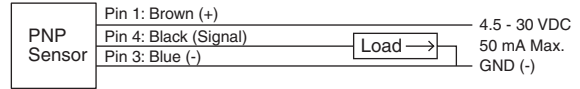
**P8S-HHSP-011 and P8S-HISN-011 Sensors**

**P8S-HHSP-011 ↔ P8S-HISN-011**

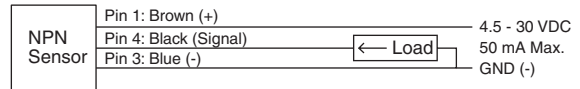
**Description:** ..... Solid state magnetoresistive (MR) sensor  
**Function:** ..... PNP (N.O.) or NPN (N.O.)  
**Voltage supply range:** ..... 4.5 - 30 VDC  
**Current consumption:** ..... Max. 9 mA @ 24 V  
**Voltage drop:** ..... Max. 1.2 V  
**Max. switching current:** ..... 50 mA  
**Reverse polarity protection:** ..... Yes  
**Short circuit (transient) protection:** ..... Yes  
**Temperature range:** ..... -10°C to 70°C (14°F to 158°F)  
**Protection class:** ..... IP67  
**Response frequency:** ..... 1 kHz



**P8S-HHSP-011**



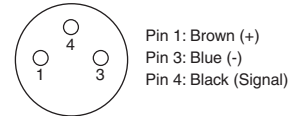
**P8S-HISN-011**



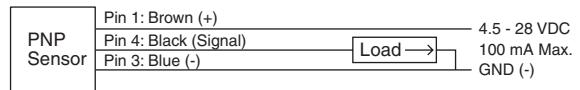
**P8S-HHSP-017 and P8S-HHSN-017 Sensors**

**P8S-HHSP-017 ↔ P8S-HHSN-017**

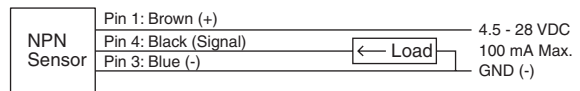
**Description:** ..... Magnetoresistive 4mm Dovetail  
**Function:** ..... PNP (N.O.) or NPN (N.O.)  
**Voltage supply range:** ..... 4.5 - 28 VDC  
**Current consumption:** ..... Max. 10 mA @ 24 V  
**Voltage drop:** ..... Max. 0.5 V  
**Max. switching current:** ..... 100 mA  
**Reverse polarity protection:** ..... Yes  
**Short circuit (transient) protection:** ..... Yes  
**Temperature range:** ..... -10°C to 70°C (14°F to 158°F)  
**Protection class:** ..... IP67  
**Response frequency:** ..... 1 kHz  
**Hysteresis:** ..... <0.2 mm  
**Repeatability:** ..... <0.1 mm  
**Insulation resistance:** ..... Min 100 M OHM (Lead to case @ 500 VDC)  
**Withstand voltage:** ..... (Lead to case) 1000 VAC RMS for 1 min or 1500 VAC RMS for 2 sec



**P8S-HHSP-017**



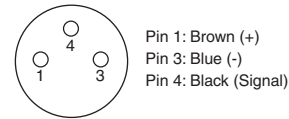
**P8S-HHSN-017**



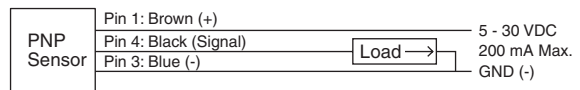
**P8S-HISP-011 and P8S-HISN-011 Sensors**

**P8S-HISP-011 ↔ P8S-HISN-011**

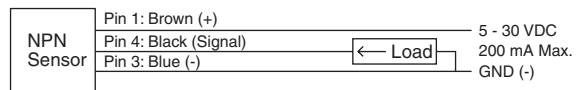
**Description:** ..... Inductive 8mm proximity sensor  
**Connection:** ..... 3-pole quick disconnect  
**Function:** ..... PNP (N.O.) or NPN (N.O.)  
**Indicator:** ..... LED  
**Load current:** ..... 200 mA max.  
**Internal voltage drop:** ..... < 1 V  
**Current consumption:** ..... 15 mA max.  
**Operating voltage:** ..... 5 - 30 VDC  
**Reverse polarity protection:** ..... Yes  
**Response frequency:** ..... 800 - 1000 Hz  
**Relative humidity:** ..... 35 - 95%  
**Shielded design:** ..... Yes  
**Sensing range:** ..... 1.5 mm  
**Temperature range:** ..... -25°C to 7°C (-13°F to 45°F)  
**NEMA rating:** ..... 6  
**IEC rating:** ..... IP67  
**Ratings:** ..... CE, ISO 9001



**P8S-HISP-011**



**P8S-HISN-011**



Automation Products  
 Grippers  
 Slide Tables  
 Rotary Tables  
 Escapements  
 Sensors & Fittings

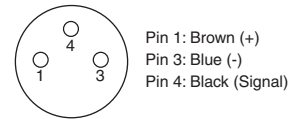


For inventory, lead times, and kit lookup, visit [www.pdnplu.com](http://www.pdnplu.com)

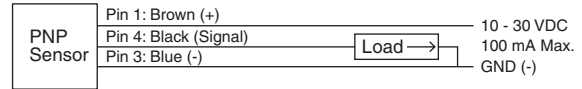
**P8S-HISP-014 and P8S-HISN-014 Sensors**

**P8S-HISP-014 ↔ P8S-HISN-014**

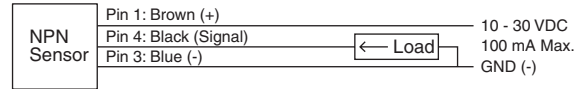
**Description:** ..... Inductive 4mm proximity sensor  
**Connection:** ..... 3-pole quick disconnect  
**Function:** ..... PNP (N.O.) or NPN (N.O.)  
**Indicator:** ..... LED  
**Load current:** ..... 100 mA max.  
**Internal voltage drop:** ..... < 2.5 V  
**Current consumption:** ..... 18 mA  
**Operating voltage:** ..... 10 - 30 VDC  
**Reverse polarity protection:** ..... Yes  
**Response frequency:** ..... 5 kHz  
**Relative humidity:** ..... 35 - 95%  
**Shielded design:** ..... Yes  
**Sensing range:** ..... 1.0 mm  
**Temperature range:** ..... -25°C to 75°C (-13°F to 167°F)  
**NEMA rating:** ..... 6  
**IEC rating:** ..... IP67  
**Ratings:** ..... CE, ISO 9001



**P8S-HISP-014**



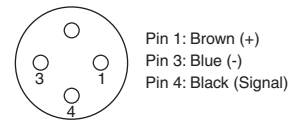
**P8S-HISN-014**



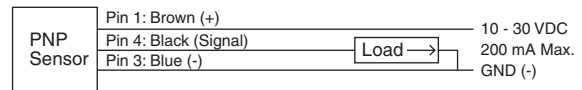
**P8S-HISP-017 and P8S-HISN-017 Sensors**

**P8S-HISP-017 ↔ P8S-HISN-017**

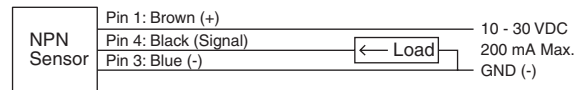
**Description:** ..... Inductive 12mm proximity sensor  
**Connection:** ..... 4-pole quick disconnect  
**Function:** ..... PNP (N.O.) or NPN (N.O.)  
**Indicator:** ..... 360° LED  
**Load current:** ..... 200 mA max.  
**Internal voltage drop:** ..... < 2.0 V  
**Current consumption:** ..... 10 mA max.  
**Operating voltage:** ..... 10 - 30 VDC  
**Reverse polarity protection:** ..... Yes  
**Response frequency:** ..... 2 kHz  
**Shielded design:** ..... Yes  
**Sensing range:** ..... 4 mm  
**Temperature range:** ..... -25°C to 75°C (-13°F to 167°F)  
**NEMA rating:** ..... 6  
**IEC rating:** ..... IP67  
**Ratings:** ..... UL, CSA, CE



**P8S-HISP-017**



**P8S-HISN-017**



Automation  
 Products

Grippers

Slide  
 Tables

Rotary  
 Tables

Escapements

Sensors &  
 Fittings



For inventory, lead time, and kit  
 lookup, visit [www.pdnplu.com](http://www.pdnplu.com)

**Fittings**



Male Connector	Thread (BSPP) / Tube	3mm	4mm (5/32 in)	6mm	8mm (5/16 in)	10mm	12mm
	M3	<b>68LF-3M-M3</b>					
M5	<b>68LF-3M-M5</b>		<b>68LF-4M-M5</b>	<b>68LF-6M-M5</b>			
1/8			<b>68LF-4M-2G</b>	<b>68LF-6M-2G</b>	<b>68LF-8M-2G</b>		
1/4			<b>68LF-4M-4G</b>	<b>68LF-6M-4G</b>	<b>68LF-8M-4G</b>	<b>68LF-10M-4G</b>	<b>68LF-12M-4G</b>
3/8				<b>68LF-6M-6G</b>	<b>68LF-8M-6G</b>	<b>68LF-10M-6G</b>	<b>68LF-12M-6G</b>
1/2				<b>68LF-6M-8G</b>	<b>68LF-8M-8G</b>	<b>68LF-10M-8G</b>	<b>68LF-12M-8G</b>



Male Elbow 90 Degree Swivel	Thread (BSPP) / Tube	3mm	4mm (5/32 in)	6mm	8mm (5/16 in)	10mm	12mm
	M3	<b>369PLP-3M-M3</b>		<b>369PLP-4M-M3</b>			
M5	<b>369PLP-3M-M5</b>		<b>369PLP-4M-M5</b>	<b>369PLP-6M-M5</b>			
1/8			<b>369PLP-4M-2G</b>	<b>369PLP-6M-2G</b>	<b>369PLP-8M-2G</b>		
1/4			<b>369PLP-4M-4G</b>	<b>369PLP-6M-4G</b>	<b>369PLP-8M-4G</b>	<b>369PLP-10M-4G</b>	<b>369PLP-12M-4G</b>
3/8				<b>369PLP-6M-6G</b>	<b>369PLP-8M-6G</b>	<b>369PLP-10M-6G</b>	<b>369PLP-12M-6G</b>
1/2				<b>369PLP-6M-8G</b>	<b>369PLP-8M-8G</b>	<b>369PLP-10M-8G</b>	<b>369PLP-12M-8G</b>



Flow Control Right Angle	Thread (BSPP) / Tube	3mm	4mm (5/32 in)	6mm	8mm (5/16 in)	10mm	12mm
	M3	<b>FCM731-3M-M3</b>		<b>FCM731-4M-M3</b>			
M5	<b>FCM731-3M-M5</b>		<b>FCM731-4M-M5</b>	<b>FCM731-6M-M5</b>			
1/8			<b>FCM731-4M-2G</b>	<b>FCM731-6M-2G</b>	<b>FCM731-8M-2G</b>		
1/4				<b>FCM731-6M-4G</b>	<b>FCM731-8M-4G</b>	<b>FCC731-10M-4G</b>	
3/8					<b>FCM731-8M-6G</b>	<b>FCC731-10M-6G</b>	<b>FCC731-12M-6G</b>
1/2							<b>FCC731-12M-8G</b>

<b>Automation Products</b>
Grippers
Slide Tables
Rotary Tables
Escapements
Sensors & Fittings



For inventory, lead times, and kit lookup, visit [www.pdnplu.com](http://www.pdnplu.com)

**Rodless Design  
Pneumatic Cylinders**

**OSP-P Series - Band Type Rodless**

System Concept & Components	G2-G8
<b>Standard Series</b>	
Features	G9-G10
Ordering Information	G11
Options / Technical Data	G12-G15
Dimensional Data	G16-G19
3/2 Way Valves VOE	G20-G21
Active Brake	G22-G23
Accessories	G24-G35
Clean Room	G36-G39
Bi-Parting	G40-G42

**Linear Guides**

Features	G43-G44
SLIDELINE	G45-G49
POWERSLIDE	G50-G53
PROLINE	G54-G58
STARLINE	G59-G63
KF	G64-G70
HD	G71-G78
Accessories	G79-G86
Sensors	G87-G94
Sensoflex	G95-G97

**P1X Series - Band Type Rodless**

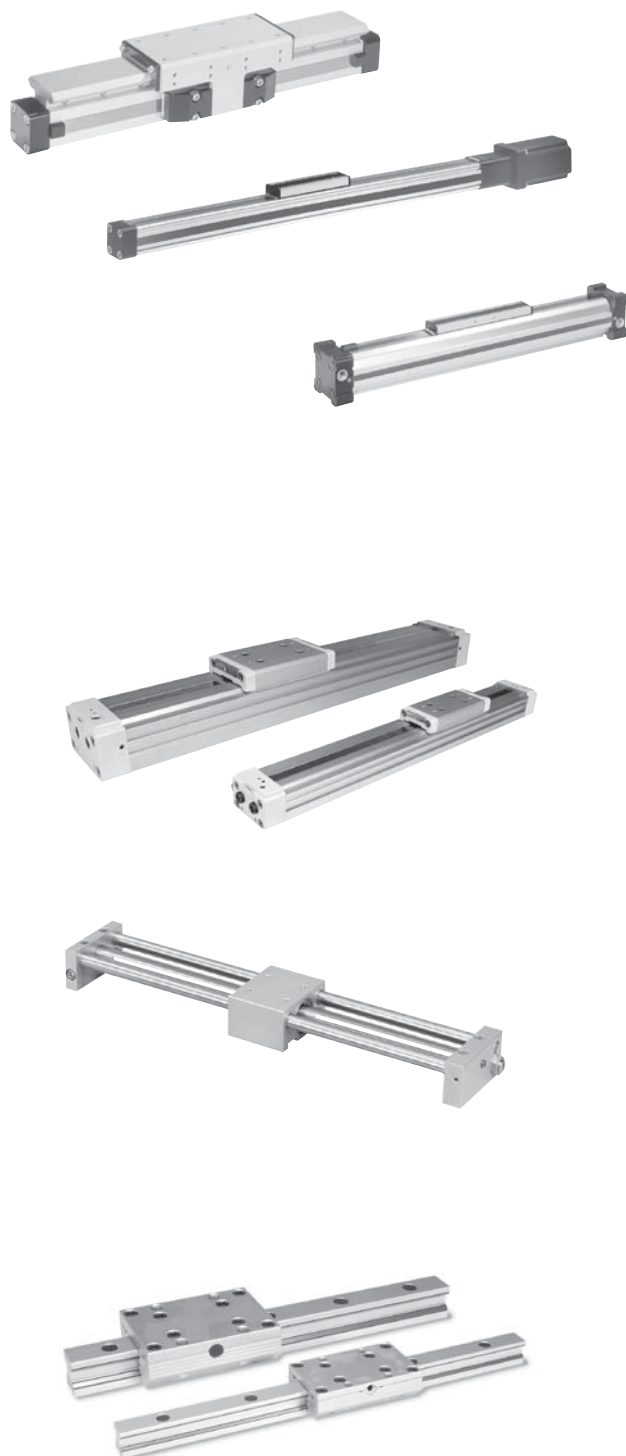
Features	G98
Ordering Information	G99
Specifications / Technical Data	G100-G104
Dimensional Data	G105-G114
Accessories	G115

**P1Z Series - Magnetically Coupled Rodless**

<b>Basic Features</b>	G116
Ordering Information	G117
Specifications / Technical Data	G118-G119
Dimensional Data	G120
Accessories	G121
<b>Guided Features</b>	G122
Ordering Information	G123
Specifications / Technical Data	G124-G125
Dimensional Data	G126
Accessories	G127

**GDL Series - Rails & Cassettes**

Features	G130-G131
Ordering Information / Stroke Lengths	G132
Specifications	G133-G134
Dimensional Data	G135-G136
Accessories	G137



**G**  
**Rodless Pneumatic  
Cylinders**



For inventory, lead time, and kit lookup, visit [www.pdnplu.com](http://www.pdnplu.com)



**ATTENTION!**

Contact PARKER-ORIGA for sizing software and/or technical assistance 877-321-4736

All dimensions are in European-Standard.  
 Please convert all in US-Standard.

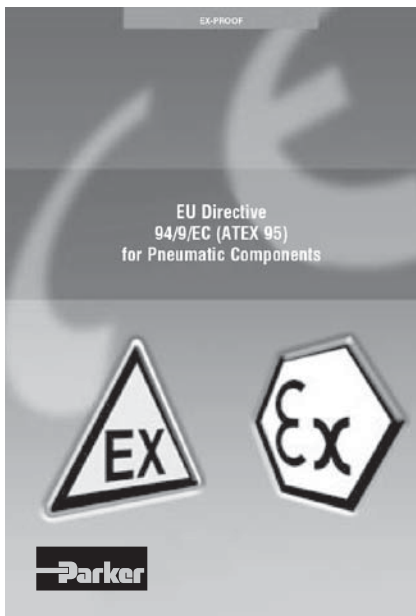
PARKER-ORIGA rodless pneumatic cylinders are the first rodless cylinders that have been approved for use in potentially explosive atmospheres in Equipment Group II, Category 2 GD

The Cylinders are to the ATEX Certification 94/9/EG (ATEX 95) for Pneumatic Components.

**Conversion Table**

Multiply	By	To Obtain
millimeters	.03937	inches
newtons	.2248	lbs.(F)
newton-meters	8.8512	in-lbs
kilograms	2.205	lbs.
inches	25.4	millimeters
lbs.(F)	4.448	newtons
in-lbs	.113	newtons-meters
lbs.	.45359	kilograms

- G**
- Rodless Pneumatic Cylinders
- OSP-P Series
- P1X Series
- P1Z Series
- GDL Series



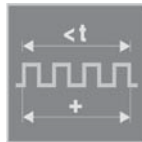
for use in Ex-Areas



for Clean Room Applications certified to DIN EN ISO 14644-1



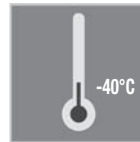
Stainless steel hardware for special applications



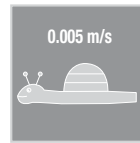
with special pneumatic cushioning system for cycle time optimization, for Ø 16 to 50 mm – on request



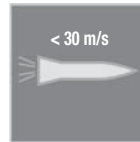
High Temperature Version for temperatures up to +100°C



Low Temperature Version for temperatures up to -40°C (25, 32, 40mm Ø)



Slow Speed Version v = 0.005 – 0.2 m/s



High Speed Version v<sub>max.</sub> = 30 m/s (16, 25, 32mm Ø)

2D & 3D CAD Drawings can be downloaded from website [www.parker.com/pneu/rodless](http://www.parker.com/pneu/rodless)



For inventory, lead times, and kit lookup, visit [www.pdnplu.com](http://www.pdnplu.com)



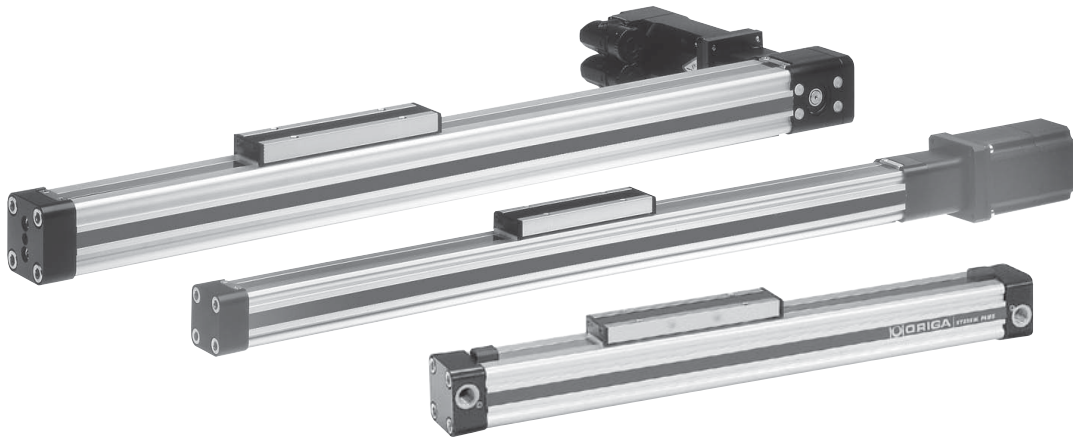
**One Concept – Pneumatic**

Based on the ORIGA rodless cylinder, proven in world wide markets, PARKER-ORIGA now offers the complete pneumatic solution for linear systems. Designed for absolute reliability, high performance, ease of use and optimized engineering the ORIGA SYSTEM PLUS satisfies even the most demanding applications.

**ORIGA SYSTEM PLUS**

is a totally modular concept which offers pneumatic actuation, with guidance options to suit the exact needs of individual installations.

The actuators at the core of the system all have a common aluminum extruded profile, with double dovetail mounting rails on three sides, these are the principle building blocks of the system to which all modular options are directly attached.

**SYSTEM MODULARITY**

- Pneumatic Drive
  - For all round versatility and convenience, combining ease of control and broad performance capability. Ideally suited for point-to point operations, reciprocating movements and simple traverse / transfer applications.
- Different guidance options provide the necessary level of precision, performance and duty for various applications.
- Compact solutions, which are simple to install and can be easily retrofitted.
- Valves and control options can be directly mounted to the actuator system.
- Diverse mounting options to provide total installation flexibility.

**G**Rodless Pneumatic  
CylindersOSP-P  
SeriesP1X  
SeriesP1Z  
SeriesGDL  
Series

For inventory, lead time, and kit lookup, visit [www.pdnplu.com](http://www.pdnplu.com)

G3

**Parker Hannifin Corporation**  
Pneumatic Division  
Richland, Michigan  
[www.parker.com/pneumatics](http://www.parker.com/pneumatics)

# The System Concept

# Rodless Pneumatic Cylinders OSP-P Series

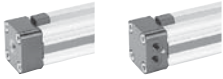
## Basic Linear Drive



### STANDARD VERSION

- OSP-P

## Air Connection on the End-face or both at One End



- OSP-P

## Clean Room Cylinder certified to DIN EN ISO 146644-1



- Series OSP-P

## Bi-parting Version



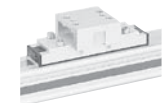
- OSP-P

## Integrated 3/2 Way Valves



- OSP-P

## Clevis Mounting



- OSP-P

## End Cap Mounting



- OSP-P

## Mid-Section Support



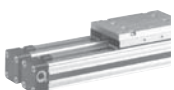
- OSP-P

## Inversion Mounting



- OSP-P

## Joint Clamp Connection



- OSP-P

## Multiplex Connection



- OSP-P

## Linear Guides



### SLIDELINE

- OSP-P



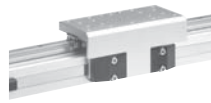
### POWERSLIDE

- OSP-P



### PROLINE

- OSP-P



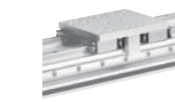
### STARLINE

- OSP-P



### KF - Recirculating Ball Bearing

- OSP-P



### HD - Heavy Duty

- OSP-P

## Intermediate Stop Module



### ZSM

- OSP-P

## Brakes



- Active Brakes
- Passive Brakes

## Magnetic Switches



- OSP-P

## SENSOFLEX – Measuring System



- SFI-plus

## Variable Stop VS



- OSP-P with Linear Guide STL, KF, HD


**G**  
 Rodless Pneumatic  
 Cylinders  
 OSP-P  
 Series  
 P1X  
 Series  
 P1Z  
 Series  
 GDL  
 Series



For inventory, lead times, and kit lookup, visit [www.pdnplu.com](http://www.pdnplu.com)

<b>Linear Drives</b>	OSP-P10	OSP-P16	OSP-P25	OSP-P32	OSP-P40	OSP-P50	OSP-P63	OSP-P80
<b>Specifications</b>								
Theoretical Force at 6 bar (N)	47	120	295	483	754	1178	1870	3010
Effective Force at 6 bar (N)	32	78	250	420	640	1000	1550	2600
Velocity v (m/s)	> 0.005	> 0.005	> 0.005	> 0.005	> 0.005	> 0.005	> 0.005	> 0.005
Magnetic Piston (three sides)		☐	☐	☐	☐	☐	☐	☐
Lubrication - Prelubricated	☐	☐	☐	☐	☐	☐	☐	☐
Multiple Air Ports ( 4 x 90°)		☐	☐	☐	☐	☐	☐	☐
Both Air Connections at End-face		○	○	○	○	○	○	○
Air Connection on the End-face		○	○	○	○	○	○	○
Cushioning	☐	☐	☐	☐	☐	☐	☐	☐
Cushioning Length (mm)	2,50	11	17	20	27	30	32	39
Stroke Length (mm) ▲	1 - 5500	1 - 5500	1 - 5500	1 - 5500	1 - 5500	1 - 5500	1 - 5500	1 - 5500
Pressure Range pmax (bar)	8.0	8.0	8.0	8.0	8.0	8.0	8.0	8.0
Temperature Range (°C) *	-10 – + 80	-10 – + 80	-10 – + 80	-10 – + 80	-10 – + 80	-10 – + 80	-10 – + 80	-10 – + 80
Fluorocarbon / Chemical Resistance	○	○	○	○	○	○	○	○
Stainless Steel Parts	○	○	○	○	○	○	○	○
Clevis Mounting	○	○	○	○	○	○	○	○
Slow Speed Lubrication	○	○	○	○	○	○	○	○
Duplex Connection / Multiplex Connection		on request	○	○	○	○	on request	on request
Tandem Piston	○	○	○	○	○	○	○	○
<b>Basic Cylinder</b>								
F (N)	20	120	300	450	750	1200	1650	2400
Mx (Nm)	0.2	0.45	1.5	3	6	10	12	24
My (Nm)	1	4	15	30	60	115	200	360
Mz (Nm)	0.3	0.5	3	5	8	15	24	48
<b>SLIDELINE</b>								
F (N)		325	675	925	1500	2000	2500	2500
Mx (Nm)		6	14	29	50	77	120	120
My (Nm)		11	34	60	110	180	260	260
Mz (Nm)		11	34	60	110	180	260	260
<b>PROLINE</b>								
F (N)		542	857	1171	2074	3111		
Mx (Nm)		8	16	29	57	111		
My (Nm)		12	39	73	158	249		
Mz (Nm)		12	39	73	158	249		
<b>POWERSLIDE</b>								
F (N)		1400	1400 - 3000	1400 - 3000	3000	3000 - 4000		
Mx (Nm)		14	14 - 65	20 - 65	65 - 90	90 - 140		
My (Nm)		45	63 - 175	70 - 175	175 - 250	250 - 350		
Mz (Nm)		45	63 - 175	70 - 175	175 - 250	250 - 350		
<b>STARLINE</b>								
F (N)		1000	3100	3100	4000-7500	4000-7500		
Mx (Nm)		15	50	62	150	210		
My (Nm)		30	110	160	400	580		
Mz (Nm)		30	110	160	400	580		
- Variable Stop		○	○	○	○	○		

- ☐ = Standard Version
- ▲ = Longer Strokes on Request
- \* = Other Temperature Ranges on Request
- = Option
- X = Not Applicable

  
**Rodless Pneumatic Cylinders**  
 OSP-P Series  
 P1X Series  
 P1Z Series  
 GDL Series



For inventory, lead time, and kit lookup, visit [www.pdnplu.com](http://www.pdnplu.com)

Modular Components Overview

	OSP-P10	OSP-P16	OSP-P25	OSP-P32	OSP-P40	OSP-P50	OSP-P63	OSP-P80
<b>Linear Drives</b>								
<b>KF Guide</b>								
F (N)		1000	3100	3100	4000-7500	4000-7500		
Mx (Nm)		12	35	44	119	170		
My (Nm)		25	90	133	346	480		
Mz (Nm)		25	90	133	346	480		
- Variable Stop		○	○	○	○	○		
<b>HD Heavy Duty Guide</b>								
F (N)			6000	6000	15000	18000		
Mx (Nm)			260	285	8000	1100		
My (Nm)			320	475	1100	1400		
Mz (Nm)			320	475	1100	1400		
- Variable Stop			○	○	○	○		
- Intermediate Stop Module			○					
<b>Active Brake</b>								
Braking Force at 6 bar (brake surface dry) (N)								
<b>SLIDELINE SL / PROLINE PL with Brakes</b>								
<b>Active Brake</b>								
SL Braking Force at 6 bar (brake surface dry) (N)			325	545	825	1200		
PL Braking Force at 6 bar (brake surface dry) (N)			on request	on request	on request	on request		
<b>Passive Brake Multibrake</b>								
SL Braking Force at 6 bar (brake surface dry) (N)			470	790	1200	1870	2900	2900
PL Braking Force at 6 bar (brake surface dry) (N)			315	490	715	1100		
<b>Magnetic Switches</b>								
Standard Version	○	○	○	○	○	○	○	○
T-Nut Version	○	○	○	○	○	○	○	○
<b>Displacement Measuring Systems</b>								
SFI-plus Incremental			○	○	○	○	○	○
<b>Integrated Valves 3/2 WV NO VOE</b>								
			○	○	○	○	on request	on request
<b>Mountings</b>								
End Cap Mounting / Mid-Section Support	○	○	○	○	○	○	○	○
Inversion Mounting		○	○	○	○	○	○	○
Shock Absorber for Intermediate Positioning			on request	on request	on request	on request		
Adaptor Profile / T-Nut Profile		○	○	○	○	○		
<b>Special Cylinders</b>								
Special Pneumactical Cushioning System		on request	on request	on request	on request	on request		
Clean Room Cylinders to DIN EN ISO 14644-1		○	○	○				
Bi-parting Version					○			
High-Speed up to 30 m/s		on request	on request	on request				
□ = Standard Version ▲ = Longer Strokes on Request * = Other Temperature Ranges on Request ○ = Option X = Not Applicable								

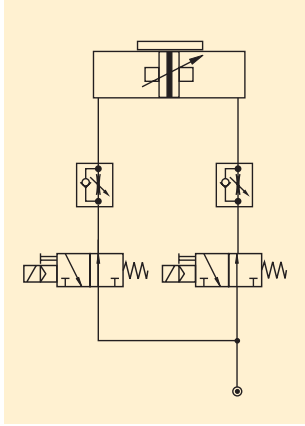
**G**  
 Rodless Pneumatic Cylinders  
 OSP-P Series  
 P1X Series  
 P1Z Series  
 GDL Series



For inventory, lead times, and kit lookup, visit [www.pdnplu.com](http://www.pdnplu.com)

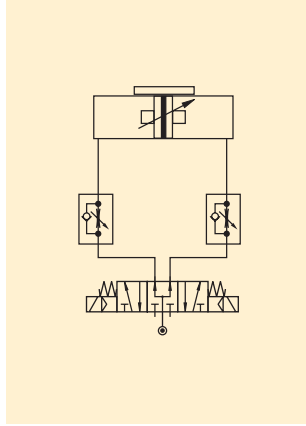
**Examples**

**Rodless Pneumatic Cylinders  
OSP-P Series**



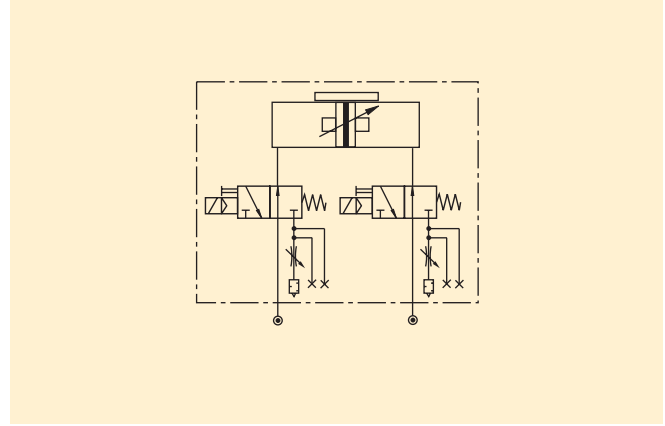
Circuit diagram for end of stroke application. Intermediate positioning is also possible.

The cylinder is controlled by two 3/2-way valves (normally open). The speed can be adjusted independently for both directions.

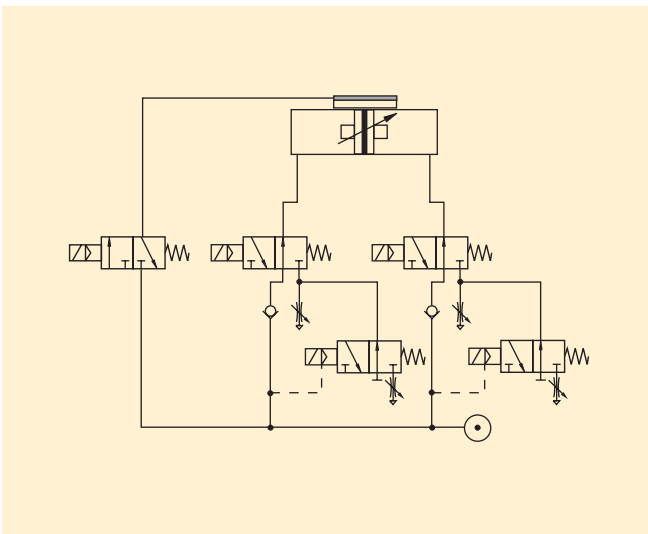


Circuit diagram for end of stroke application. Intermediate positioning is also possible.

The cylinder is controlled by a 5/3-way valve (middle position pressurized). The speed can be adjusted independently for both directions.

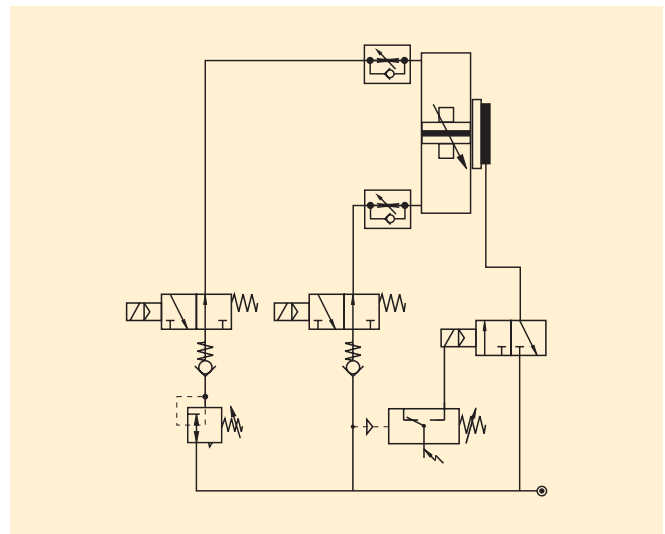


The optional integrated VOE Valves offer optimal control, and allow accurate positioning of intermediate positions and the lowest possible speeds.



Fast/Slow speed cycle control with pneumatic brake for accurate positioning at high velocities. Additional 3/2-way valves with adjustable throttle valves at the exhaust of the standard directional control valves for two displacement speeds in each direction of the piston's travel.

The valve controlling the brake is activated after the slow speed cycle is activated.



The combination of an OSP-cylinder with the passive MULTIBRAKE as shown here, allows accurate positioning and safety in case of loss of pneumatic air pressure.



Rodless Pneumatic Cylinders

OSP-P Series

P1X Series

P1Z Series

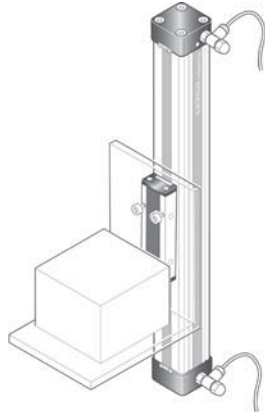
GDL Series



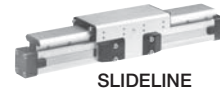
For inventory, lead time, and kit lookup, visit [www.pdnplu.com](http://www.pdnplu.com)

**ORIGA SYSTEM PLUS – rodless linear drives offer maximum flexibility for any application.**

The high load capacity of the piston can cope with high bending moments without additional guides.



Integrated guides offer optimal guidance for applications requiring high performance, easy assembly and maintenance free operation.



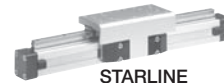
SLIDELINE



PROLINE



POWERSLIDE

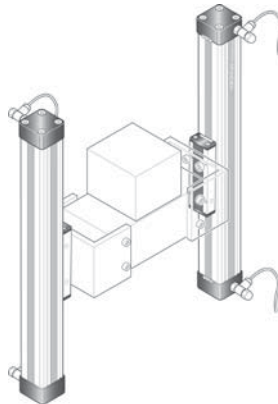


STARLINE

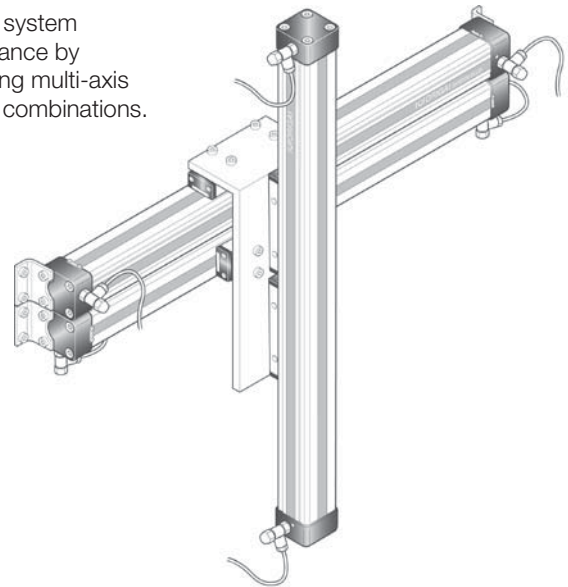


HD-Guide

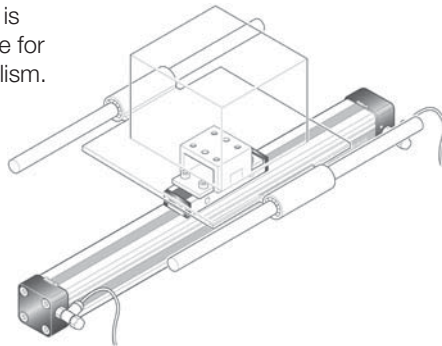
The mechanical design of the OSP-P allows synchronized movement of two cylinders.



Optimal system performance by combining multi-axis cylinder combinations.



When using external guides, the clevis mounting is used to compensate for deviations in parallelism.



<b>G</b> Rodless Pneumatic Cylinders	OSP-P Series
	P1X Series
	P1Z Series
	GDL Series

**For further information and assembly instructions, please contact your local PARKER-ORIGA dealer.**



For inventory, lead times, and kit lookup, visit [www.pdnplu.com](http://www.pdnplu.com)

**OSP-P Series**

A new generation of linear drives which can be simply and neatly integrated into any machine layout.

**A new modular linear drive system**

With this second generation linear drive the OSP-P series offers design engineers complete flexibility.

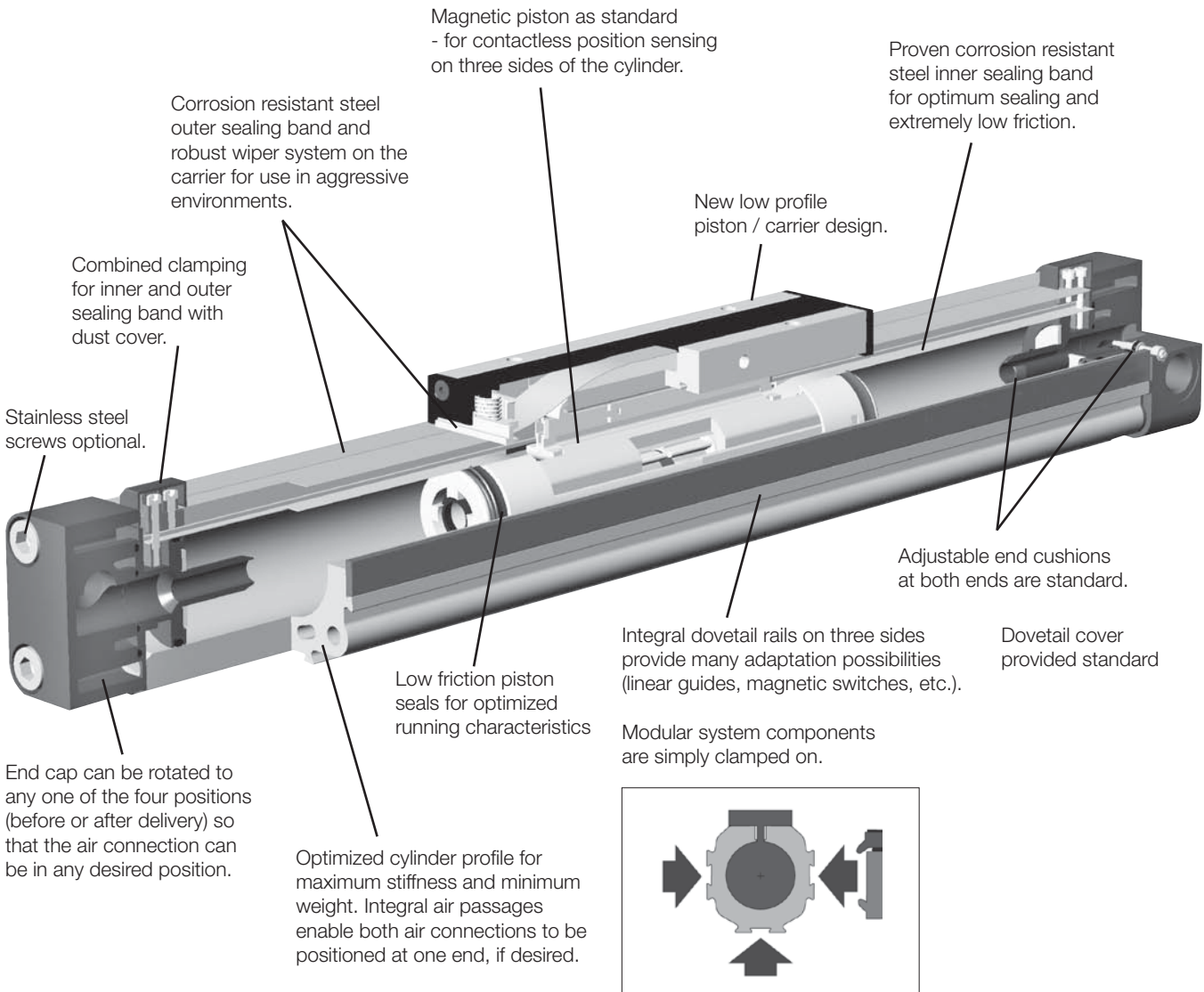
The well known ORIGA cylinder has been further developed into a combined linear actuator, guidance and control package. It forms the basis for the OSP-P linear drive system.

All additional functions are designed into modular system components which replace the previous series of cylinders.

**Mounting rails on 3 sides**

Mounting rails on 3 sides of the cylinder enable modular components such as linear guides, brakes, valves, magnetic switches etc. to be fitted to the cylinder itself. This solves many installation problems, especially where space is limited.

The modular system concept forms an ideal basis for additional customer-specific functions.



G
Rodless Pneumatic Cylinders
OSP-P Series
P1X Series
P1Z Series
GDL Series



For inventory, lead time, and kit lookup, visit [www.pdnplu.com](http://www.pdnplu.com)

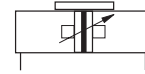
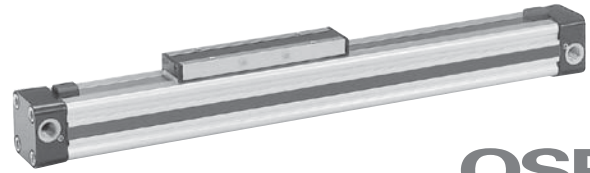
### Features

#### Standard Features:

- Double-acting with adjustable cushions
- With magnetic piston for position sensing
- Standard stroke lengths to 5500mm, long stroke versions available upon request
- End cap can be rotated 4 x 90° to position ports as desired

#### Optional Features:

- Clean room cylinders
- Stainless steel screws
- Slow speed lubrication
- Fluorocarbon seals -14°F to 212°F (-10°C to 100°C)
- Single end porting
- Integrated valves
- Integrated bearing options



#### Operating information

Operating pressure:	116 PSIG (8 bar)
Temperature range:	14°F to 176°F (-10°C to 80°C)
Filtration requirements:	Filtered, nonlubricated compressed air

### Specifications

- Type: Rodless cylinder
- Series: OSP-P
- Stroke length: 5.5m (216 inches)
- System: Double-acting, with cushions and magnetic piston
- Mounting: See drawings
- Air connection: Threaded
- Weight (mass): See table
- Installation: In any position
- Lubrication: Prelubricated at the factory (additional oil mist lubrication not required)
- Option: special slow speed grease

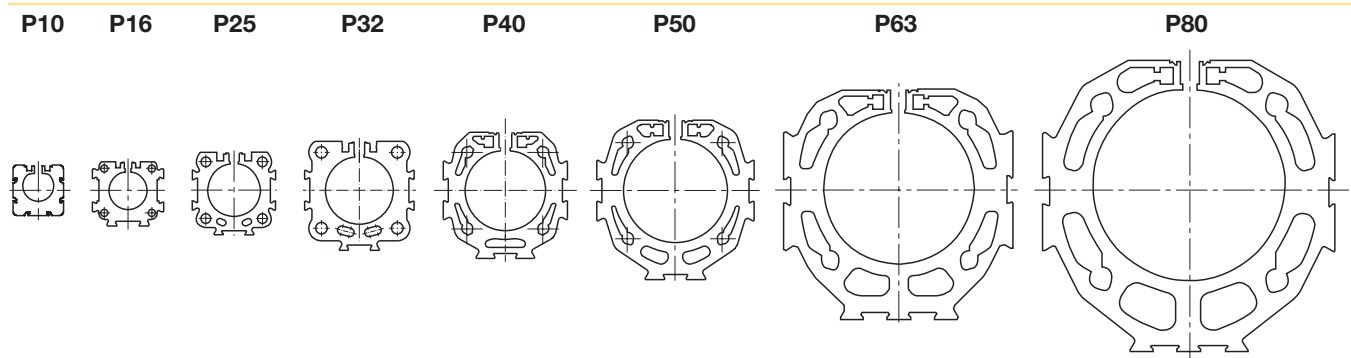
### Material specifications

Cylinder profile	Anodized aluminum
Carrier (piston)	Anodized aluminum
End caps	Aluminum, lacquered / plastic (P10)
Sealing bands	Corrosion resistant steel
Seals	NBR (Option: Fluorocarbon)
Screws	Galvanized steel Option: stainless steel
Dust covers, wipers	Composite

### Weight (mass) kg

Cylinder series (Basic cylinder)	Weight (Mass) kg	
	at 0mm stroke	per 100mm stroke
OSP-P10	0.087	0.052
OSP-P16	0.22	0.1
OSP-P25	0.65	0.197
OSP-P32	1.44	0.354
OSP-P40	1.95	0.415
OSP-P50	3.53	0.566
OSP-P63	6.41	0.925
OSP-P80	12.46	1.262

### Size Comparison



**G**  
 Rodless Pneumatic Cylinders  
 OSP-P Series  
 P1X Series  
 P1Z Series  
 GD L Series



For inventory, lead times, and kit lookup, visit [www.pdnplu.com](http://www.pdnplu.com)

G10

**Parker Hannifin Corporation**  
 Pneumatic Division  
 Richland, Michigan  
[www.parker.com/pneumatics](http://www.parker.com/pneumatics)



**Ordering information for OSP-P rodless standard pneumatic series**

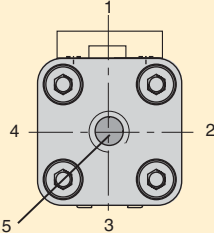
1-4	5-6	7	8	9	10	11	12-16	17	18	19	20	21	22	23	24	25
<b>OSP</b>	<b>P</b>	<b>25</b>	<b>0</b>	<b>1</b>	<b>0</b>	<b>0</b>	<b>01100</b>	<b>0</b>	<b>0</b>	<b>0</b>	<b>0</b>	<b>0</b>	<b>0</b>	<b>1</b>	<b>0</b>	<b>0</b>

<table border="1" style="width:100%; border-collapse: collapse;"> <tr><td colspan="2"><b>Bore</b></td></tr> <tr><td>10</td><td></td></tr> <tr><td>16</td><td></td></tr> <tr><td>25</td><td></td></tr> <tr><td>32</td><td></td></tr> <tr><td>40</td><td></td></tr> <tr><td>50</td><td></td></tr> <tr><td>63</td><td></td></tr> <tr><td>80</td><td></td></tr> </table> <table border="1" style="width:100%; border-collapse: collapse;"> <tr><td colspan="2"><b>Piston style</b></td></tr> <tr><td>0</td><td>Standard</td></tr> <tr><td>1</td><td>Tandem</td></tr> </table> <table border="1" style="width:100%; border-collapse: collapse;"> <tr><td colspan="2"><b>Porting configurations†</b></td></tr> <tr><td>0</td><td>Standard</td></tr> <tr><td>1</td><td>End face (position #5)‡</td></tr> <tr><td>2</td><td>Single end ports</td></tr> <tr><td>3</td><td>Left stand (pos #2), Right end face (pos #5)</td></tr> <tr><td>4</td><td>Right stand (pos #2), Left end face (pos #5)</td></tr> <tr><td>6</td><td>Single end porting, end face = (50,63,80)</td></tr> <tr><td>A</td><td>3/2 way valve VOE, 24V = (25,32,40,50)</td></tr> <tr><td>B</td><td>3/2 way valve VOE, 220V~/110V = (25,32,40,50)</td></tr> <tr><td>C</td><td>3/2 way valve VOE, 48V = (25,32,40,50)</td></tr> <tr><td>E</td><td>3/2 way valve VOE, 110V = (25,32,40,50)</td></tr> <tr><td>S</td><td>Special</td></tr> </table>	<b>Bore</b>		10		16		25		32		40		50		63		80		<b>Piston style</b>		0	Standard	1	Tandem	<b>Porting configurations†</b>		0	Standard	1	End face (position #5)‡	2	Single end ports	3	Left stand (pos #2), Right end face (pos #5)	4	Right stand (pos #2), Left end face (pos #5)	6	Single end porting, end face = (50,63,80)	A	3/2 way valve VOE, 24V = (25,32,40,50)	B	3/2 way valve VOE, 220V~/110V = (25,32,40,50)	C	3/2 way valve VOE, 48V = (25,32,40,50)	E	3/2 way valve VOE, 110V = (25,32,40,50)	S	Special	<table border="1" style="width:100%; border-collapse: collapse;"> <tr><td colspan="2"><b>Lubrication</b></td></tr> <tr><td>0</td><td>Standard</td></tr> <tr><td>1</td><td>Slow speed</td></tr> <tr><td>4</td><td>Food</td></tr> <tr><td>5</td><td>Clean room</td></tr> <tr><td>S</td><td>Special</td></tr> </table> <table border="1" style="width:100%; border-collapse: collapse;"> <tr><td colspan="2"><b>Stroke</b></td></tr> <tr><td colspan="2">x x x x x</td></tr> </table> <table border="1" style="width:100%; border-collapse: collapse;"> <tr><td colspan="2"><b>Cushions / Stops</b></td></tr> <tr><td>0</td><td>Standard</td></tr> <tr><td>S</td><td>Special</td></tr> </table> <table border="1" style="width:100%; border-collapse: collapse;"> <tr><td colspan="2"><b>Piston mounting</b></td></tr> <tr><td>0</td><td>Standard*</td></tr> <tr><td>1</td><td>Floating mount (NR24) Clevis</td></tr> <tr><td>8</td><td>Joint clamp plate (NR24)</td></tr> <tr><td>S</td><td>Special</td></tr> </table> <table border="1" style="width:100%; border-collapse: collapse;"> <tr><td colspan="2"><b>Seals</b></td></tr> <tr><td>0</td><td>Buna-N</td></tr> <tr><td>1</td><td>Fluorocarbon</td></tr> </table> <table border="1" style="width:100%; border-collapse: collapse;"> <tr><td colspan="2"><b>Fasteners</b></td></tr> <tr><td>0</td><td>Chrome plated</td></tr> <tr><td>1</td><td>Stainless steel</td></tr> <tr><td>3</td><td>Xylan coated &amp; stainless steel fasteners</td></tr> <tr><td>S</td><td>Special</td></tr> </table> <table border="1" style="width:100%; border-collapse: collapse;"> <tr><td colspan="2"><b>Guides / Brakes</b></td></tr> <tr><td>0</td><td>None</td></tr> <tr><td>A</td><td>Active brake (basic OSP)</td></tr> <tr><td>M</td><td>Inversion (NR30) (16 - 80mm bore only)</td></tr> <tr><td>N</td><td>Joint clamp (25,32,40,50)</td></tr> </table>	<b>Lubrication</b>		0	Standard	1	Slow speed	4	Food	5	Clean room	S	Special	<b>Stroke</b>		x x x x x		<b>Cushions / Stops</b>		0	Standard	S	Special	<b>Piston mounting</b>		0	Standard*	1	Floating mount (NR24) Clevis	8	Joint clamp plate (NR24)	S	Special	<b>Seals</b>		0	Buna-N	1	Fluorocarbon	<b>Fasteners</b>		0	Chrome plated	1	Stainless steel	3	Xylan coated & stainless steel fasteners	S	Special	<b>Guides / Brakes</b>		0	None	A	Active brake (basic OSP)	M	Inversion (NR30) (16 - 80mm bore only)	N	Joint clamp (25,32,40,50)	<table border="1" style="width:100%; border-collapse: collapse;"> <tr><td colspan="2"><b>Dovetail cover</b></td></tr> <tr><td>0</td><td>Standard</td></tr> <tr><td>X</td><td>Without cover rail</td></tr> <tr><td>S</td><td>Special</td></tr> </table> <table border="1" style="width:100%; border-collapse: collapse;"> <tr><td colspan="2"><b>Version</b></td></tr> <tr><td>0</td><td>Standard</td></tr> </table> <table border="1" style="width:100%; border-collapse: collapse;"> <tr><td colspan="2"><b>Additional carriages**</b></td></tr> <tr><td>0</td><td>None</td></tr> </table> <table border="1" style="width:100%; border-collapse: collapse;"> <tr><td colspan="2"><b>Mounting</b></td></tr> <tr><td>0</td><td>None</td></tr> <tr><td>1</td><td>A1 (10,16,25,32)</td></tr> <tr><td>2</td><td>A2 (16,25,32)</td></tr> <tr><td>3</td><td>A3 (25,32)</td></tr> <tr><td>4</td><td>B1 (25,32)</td></tr> <tr><td>6</td><td>B3 (16)</td></tr> <tr><td>7</td><td>B4 (25,32)</td></tr> <tr><td>8</td><td>B5 (32)</td></tr> <tr><td>9</td><td>C1 (40,50,63,80)</td></tr> <tr><td>A</td><td>C2 (40,50)</td></tr> <tr><td>B</td><td>C3 (40,50,63,80)</td></tr> <tr><td>C</td><td>C4 (40,50)</td></tr> </table>	<b>Dovetail cover</b>		0	Standard	X	Without cover rail	S	Special	<b>Version</b>		0	Standard	<b>Additional carriages**</b>		0	None	<b>Mounting</b>		0	None	1	A1 (10,16,25,32)	2	A2 (16,25,32)	3	A3 (25,32)	4	B1 (25,32)	6	B3 (16)	7	B4 (25,32)	8	B5 (32)	9	C1 (40,50,63,80)	A	C2 (40,50)	B	C3 (40,50,63,80)	C	C4 (40,50)	<table border="1" style="width:100%; border-collapse: collapse;"> <tr><td colspan="2"><b>End Cap Port Position† Δ</b></td></tr> <tr><td>0</td><td>l+r 0° (pos #2)</td></tr> <tr><td>1</td><td>l+r 90° (pos #3)</td></tr> <tr><td>2</td><td>l+r 180° (pos #4)</td></tr> <tr><td>3</td><td>l+r 270° same face as outerband (pos #1)</td></tr> <tr><td>4</td><td>l 90° underneath; r 0° = in front (pos #3,2)</td></tr> <tr><td>5</td><td>l 180° at the back; r 0° = in front (pos #4,2)</td></tr> <tr><td>6</td><td>l 270° same face as outerband; r 0° = in front (pos #1,2)</td></tr> <tr><td>7</td><td>l 0° in front; r 90° = underneath (pos #2,3)</td></tr> <tr><td>8</td><td>l 180° at the back; r 90° = underneath (pos #4,3)</td></tr> <tr><td>9</td><td>l 270° same face as outerband; r 90° = underneath (pos #1,3)</td></tr> <tr><td>A</td><td>l 0° in front; r 180° = at the back (pos #2,4)</td></tr> <tr><td>B</td><td>l 90° underneath; r 180° = at the back (pos #3,4)</td></tr> <tr><td>C</td><td>l 270° same face as outerband; r 180° = at the back (pos #1,4)</td></tr> <tr><td>D</td><td>l 0° in front; r 270° = same face as outerband (pos #2,1)</td></tr> <tr><td>E</td><td>l 90° underneath; r 270° = same face as outerband (pos #3,1)</td></tr> <tr><td>F</td><td>l 180° at the back; r 270° = same face as outerband (pos #4,1)</td></tr> <tr><td>S</td><td>Special</td></tr> </table> <table border="1" style="width:100%; border-collapse: collapse;"> <tr><td colspan="2"><b>Switches ◊</b></td></tr> <tr><td>0</td><td>None</td></tr> <tr><td>1</td><td>NO Reed, P8S-GRFDX2 (All except 10mm)</td></tr> <tr><td>2</td><td>NC Reed, P8S-GEFRX1 (All except 10mm)</td></tr> <tr><td>3</td><td>PNP P8S-GPCHX+4041 (All except 10mm)</td></tr> <tr><td>4</td><td>NPN P8S-GNCHX+4041 (All except 10mm)</td></tr> <tr><td>5</td><td>NO Reed, P8S-GRFDX2 (10mm only)</td></tr> <tr><td>6</td><td>PNP 3049+4041 (10mm only)</td></tr> <tr><td>7</td><td>PNP 3753+4041 (10mm only)</td></tr> <tr><td>X</td><td>21240 SFI 0,1mm</td></tr> <tr><td>Y</td><td>21241 SFI 1mm</td></tr> <tr><td>Z</td><td>4650 SFA</td></tr> </table>	<b>End Cap Port Position† Δ</b>		0	l+r 0° (pos #2)	1	l+r 90° (pos #3)	2	l+r 180° (pos #4)	3	l+r 270° same face as outerband (pos #1)	4	l 90° underneath; r 0° = in front (pos #3,2)	5	l 180° at the back; r 0° = in front (pos #4,2)	6	l 270° same face as outerband; r 0° = in front (pos #1,2)	7	l 0° in front; r 90° = underneath (pos #2,3)	8	l 180° at the back; r 90° = underneath (pos #4,3)	9	l 270° same face as outerband; r 90° = underneath (pos #1,3)	A	l 0° in front; r 180° = at the back (pos #2,4)	B	l 90° underneath; r 180° = at the back (pos #3,4)	C	l 270° same face as outerband; r 180° = at the back (pos #1,4)	D	l 0° in front; r 270° = same face as outerband (pos #2,1)	E	l 90° underneath; r 270° = same face as outerband (pos #3,1)	F	l 180° at the back; r 270° = same face as outerband (pos #4,1)	S	Special	<b>Switches ◊</b>		0	None	1	NO Reed, P8S-GRFDX2 (All except 10mm)	2	NC Reed, P8S-GEFRX1 (All except 10mm)	3	PNP P8S-GPCHX+4041 (All except 10mm)	4	NPN P8S-GNCHX+4041 (All except 10mm)	5	NO Reed, P8S-GRFDX2 (10mm only)	6	PNP 3049+4041 (10mm only)	7	PNP 3753+4041 (10mm only)	X	21240 SFI 0,1mm	Y	21241 SFI 1mm	Z	4650 SFA
<b>Bore</b>																																																																																																																																																																																																																			
10																																																																																																																																																																																																																			
16																																																																																																																																																																																																																			
25																																																																																																																																																																																																																			
32																																																																																																																																																																																																																			
40																																																																																																																																																																																																																			
50																																																																																																																																																																																																																			
63																																																																																																																																																																																																																			
80																																																																																																																																																																																																																			
<b>Piston style</b>																																																																																																																																																																																																																			
0	Standard																																																																																																																																																																																																																		
1	Tandem																																																																																																																																																																																																																		
<b>Porting configurations†</b>																																																																																																																																																																																																																			
0	Standard																																																																																																																																																																																																																		
1	End face (position #5)‡																																																																																																																																																																																																																		
2	Single end ports																																																																																																																																																																																																																		
3	Left stand (pos #2), Right end face (pos #5)																																																																																																																																																																																																																		
4	Right stand (pos #2), Left end face (pos #5)																																																																																																																																																																																																																		
6	Single end porting, end face = (50,63,80)																																																																																																																																																																																																																		
A	3/2 way valve VOE, 24V = (25,32,40,50)																																																																																																																																																																																																																		
B	3/2 way valve VOE, 220V~/110V = (25,32,40,50)																																																																																																																																																																																																																		
C	3/2 way valve VOE, 48V = (25,32,40,50)																																																																																																																																																																																																																		
E	3/2 way valve VOE, 110V = (25,32,40,50)																																																																																																																																																																																																																		
S	Special																																																																																																																																																																																																																		
<b>Lubrication</b>																																																																																																																																																																																																																			
0	Standard																																																																																																																																																																																																																		
1	Slow speed																																																																																																																																																																																																																		
4	Food																																																																																																																																																																																																																		
5	Clean room																																																																																																																																																																																																																		
S	Special																																																																																																																																																																																																																		
<b>Stroke</b>																																																																																																																																																																																																																			
x x x x x																																																																																																																																																																																																																			
<b>Cushions / Stops</b>																																																																																																																																																																																																																			
0	Standard																																																																																																																																																																																																																		
S	Special																																																																																																																																																																																																																		
<b>Piston mounting</b>																																																																																																																																																																																																																			
0	Standard*																																																																																																																																																																																																																		
1	Floating mount (NR24) Clevis																																																																																																																																																																																																																		
8	Joint clamp plate (NR24)																																																																																																																																																																																																																		
S	Special																																																																																																																																																																																																																		
<b>Seals</b>																																																																																																																																																																																																																			
0	Buna-N																																																																																																																																																																																																																		
1	Fluorocarbon																																																																																																																																																																																																																		
<b>Fasteners</b>																																																																																																																																																																																																																			
0	Chrome plated																																																																																																																																																																																																																		
1	Stainless steel																																																																																																																																																																																																																		
3	Xylan coated & stainless steel fasteners																																																																																																																																																																																																																		
S	Special																																																																																																																																																																																																																		
<b>Guides / Brakes</b>																																																																																																																																																																																																																			
0	None																																																																																																																																																																																																																		
A	Active brake (basic OSP)																																																																																																																																																																																																																		
M	Inversion (NR30) (16 - 80mm bore only)																																																																																																																																																																																																																		
N	Joint clamp (25,32,40,50)																																																																																																																																																																																																																		
<b>Dovetail cover</b>																																																																																																																																																																																																																			
0	Standard																																																																																																																																																																																																																		
X	Without cover rail																																																																																																																																																																																																																		
S	Special																																																																																																																																																																																																																		
<b>Version</b>																																																																																																																																																																																																																			
0	Standard																																																																																																																																																																																																																		
<b>Additional carriages**</b>																																																																																																																																																																																																																			
0	None																																																																																																																																																																																																																		
<b>Mounting</b>																																																																																																																																																																																																																			
0	None																																																																																																																																																																																																																		
1	A1 (10,16,25,32)																																																																																																																																																																																																																		
2	A2 (16,25,32)																																																																																																																																																																																																																		
3	A3 (25,32)																																																																																																																																																																																																																		
4	B1 (25,32)																																																																																																																																																																																																																		
6	B3 (16)																																																																																																																																																																																																																		
7	B4 (25,32)																																																																																																																																																																																																																		
8	B5 (32)																																																																																																																																																																																																																		
9	C1 (40,50,63,80)																																																																																																																																																																																																																		
A	C2 (40,50)																																																																																																																																																																																																																		
B	C3 (40,50,63,80)																																																																																																																																																																																																																		
C	C4 (40,50)																																																																																																																																																																																																																		
<b>End Cap Port Position† Δ</b>																																																																																																																																																																																																																			
0	l+r 0° (pos #2)																																																																																																																																																																																																																		
1	l+r 90° (pos #3)																																																																																																																																																																																																																		
2	l+r 180° (pos #4)																																																																																																																																																																																																																		
3	l+r 270° same face as outerband (pos #1)																																																																																																																																																																																																																		
4	l 90° underneath; r 0° = in front (pos #3,2)																																																																																																																																																																																																																		
5	l 180° at the back; r 0° = in front (pos #4,2)																																																																																																																																																																																																																		
6	l 270° same face as outerband; r 0° = in front (pos #1,2)																																																																																																																																																																																																																		
7	l 0° in front; r 90° = underneath (pos #2,3)																																																																																																																																																																																																																		
8	l 180° at the back; r 90° = underneath (pos #4,3)																																																																																																																																																																																																																		
9	l 270° same face as outerband; r 90° = underneath (pos #1,3)																																																																																																																																																																																																																		
A	l 0° in front; r 180° = at the back (pos #2,4)																																																																																																																																																																																																																		
B	l 90° underneath; r 180° = at the back (pos #3,4)																																																																																																																																																																																																																		
C	l 270° same face as outerband; r 180° = at the back (pos #1,4)																																																																																																																																																																																																																		
D	l 0° in front; r 270° = same face as outerband (pos #2,1)																																																																																																																																																																																																																		
E	l 90° underneath; r 270° = same face as outerband (pos #3,1)																																																																																																																																																																																																																		
F	l 180° at the back; r 270° = same face as outerband (pos #4,1)																																																																																																																																																																																																																		
S	Special																																																																																																																																																																																																																		
<b>Switches ◊</b>																																																																																																																																																																																																																			
0	None																																																																																																																																																																																																																		
1	NO Reed, P8S-GRFDX2 (All except 10mm)																																																																																																																																																																																																																		
2	NC Reed, P8S-GEFRX1 (All except 10mm)																																																																																																																																																																																																																		
3	PNP P8S-GPCHX+4041 (All except 10mm)																																																																																																																																																																																																																		
4	NPN P8S-GNCHX+4041 (All except 10mm)																																																																																																																																																																																																																		
5	NO Reed, P8S-GRFDX2 (10mm only)																																																																																																																																																																																																																		
6	PNP 3049+4041 (10mm only)																																																																																																																																																																																																																		
7	PNP 3753+4041 (10mm only)																																																																																																																																																																																																																		
X	21240 SFI 0,1mm																																																																																																																																																																																																																		
Y	21241 SFI 1mm																																																																																																																																																																																																																		
Z	4650 SFA																																																																																																																																																																																																																		

Notes: 10mm bore can only have standard port locations.  
 Single end porting on 16mm bore, then end caps cannot be rotated.



**Note: Position #2 is the standard location.**

\* For Joint Clamp connecting plate, order separately  
 \*\*When selecting additional carriages, the tandem piston option must also be selected  
 † Single end ports can not be rotated in the field  
 ‡ Only available on 50mm bore


Δ Note: End cap port position  
 L = Left end cap, R = right end cap

Note: Comes in pairs

◊ Note: 2 switches will be supplied. For different quantity, please order as a separate line item.

**Sensors**  
 See section L for sensors.





For inventory, lead time, and kit lookup, visit [www.pdnplu.com](http://www.pdnplu.com)

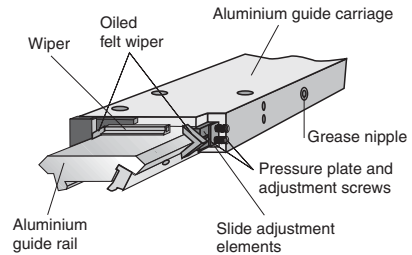
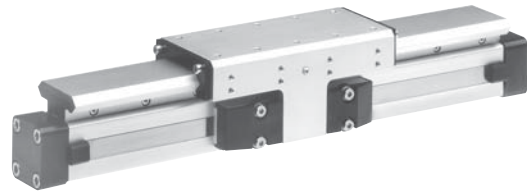
**Options**

**Plain Bearing Guide SLIDELINE**

Available on 16 to 80mm bore

**Features:**

- Adjustable composite slide elements – optional integral brake
- Integrated sealing system with wiper elements to remove dirt and lubricate the slideways
- Any length of stroke up to 5500mm

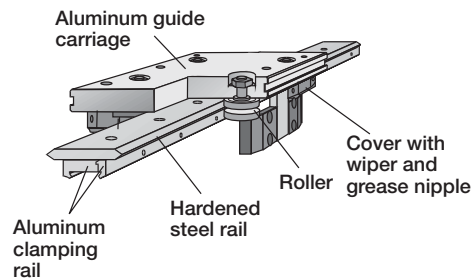
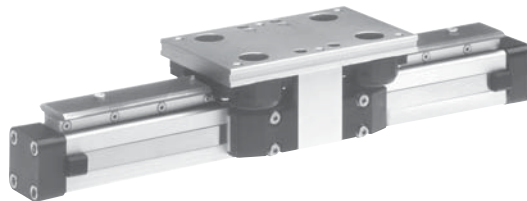


**Roller Guide POWERSLIDE**

Available on 16 to 50mm bore

**Features:**

- Anodized aluminum guide carriage with vee rollers
- Hardened steel guide rail
- Multiple guide sizes can be used on the same drive
- Max. Speed  $v = 3 \text{ m/s}$
- Integrated wiper and grease nipple
- Any length of stroke up to 3500mm

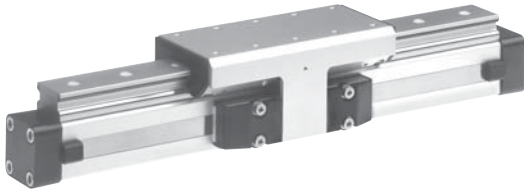


<b>G</b> Rodless Pneumatic Cylinders	
	OSP-P Series
	P1X Series
	P1Z Series
	GDL Series



For inventory, lead times, and kit lookup, visit [www.pdnplu.com](http://www.pdnplu.com)

**Other Options**

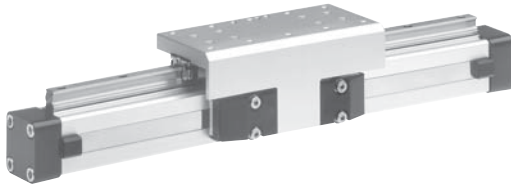


**PROLINE**

The compact aluminum roller guide for high loads and velocities and utilizes the GDL Guide Bearing



**Integrated VOE Valves**



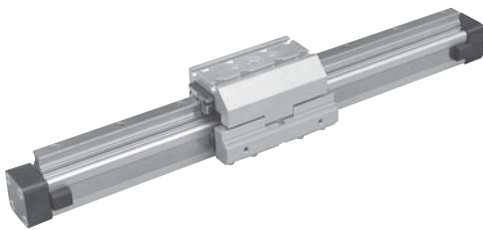
**STARLINE**

Recirculating ball bearing guide for very high loads and precision



**SENSOFLEX SFI-plus**

Incremental measuring system with 0.1 (1.0) mm resolution



**KF Guide**

Recirculating ball bearing guide – the mounting dimensions correspond to FESTO Type: DGPL-KF



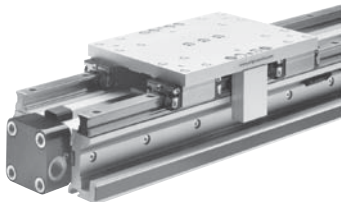
**Variable Stop VS**

The variable stop provides simple stroke limitation  
Available on STARLINE, KF and Heavy duty guide



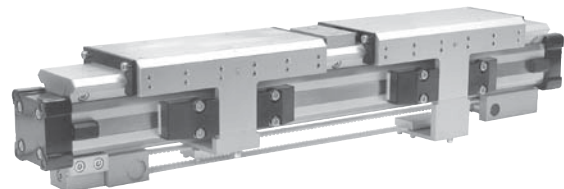
**Clean Room Version**

Certified to DIN EN ISO 14644-1



**Heavy Duty Guide HD**

For heavy duty applications



**Rodless Cylinder**

For synchronized bi-parting movements  
Available on SLIDELINE Guide Bearing only

**G**

**Rodless Pneumatic Cylinders**

**OSP-P Series**

**P1X Series**

**P1Z Series**

**GDL Series**



For inventory, lead time, and kit lookup, visit [www.pdnplu.com](http://www.pdnplu.com)

**Loads, Forces and Moments**

When sizing an OSP cylinder, consideration must be given to:

- Loads, forces and moments
- Performance of the pneumatic end cushions. The main factors are the mass to be cushioned and the piston speed (unless external cushioning is used, e. g. hydraulic shock absorbers)

To determine the maximum values for light, shock-free operation, which must not be exceeded even in dynamic operation.

**Load and moment data are based on speeds  $v \leq 0.5$  m/s.**

When working out the action force required, it is essential to take into account the friction forces generated by the specific application or load.

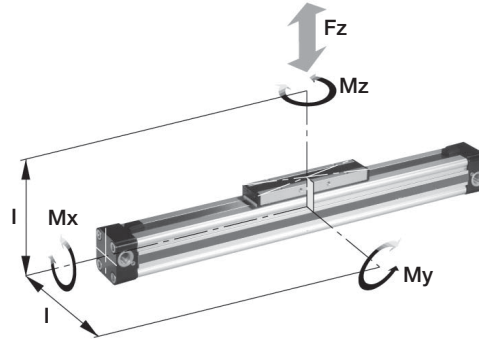
The sum total of each of these types of moments, divided by each of the maximum values, determines a Load-Moment Factor (LMF) should be equal to or less than 1.0. On horizontal mountings, the total load (L) should also be divided by the maximum load allowable and factored into the equation.

**Horizontal Mountings:**

$$\frac{L}{[L]} + \frac{M}{[M]} + \frac{Ms}{[Ms]} + \frac{Mv}{[Mv]} = LMF \leq 1.0$$

**Vertical Mountings:**

$$\frac{M}{[M]} + \frac{Ms}{[Ms]} + \frac{Mv}{[Mv]} = LMF \leq 1.0$$



$$M = F \cdot l$$

Bending moments are calculated from the center of the linear actuator

Cylinder series (mm Ø)	Theoretical output force at 6 bar N (lb)	Actual output force $F_A$ at 6 bar N (lb)	Max. moments			Max. load F N (lb)	Cushion length (mm)
			Mx Nm (in lb)	My Nm (in lb)	Mz Nm (in lb)		
<b>OSP-P10</b>	47 (10.6)	32 (7.2)	0.2 (1.8)	1 (8.9)	0.3 (2.7)	20 (4.5)	2.5 * (.09)
<b>OSP-P16</b>	120 (26.9)	78 (17.5)	0.45 (3.9)	4 (35.4)	0.5 (4.4)	120 (26.9)	11 (.43)
<b>OSP-P25</b>	295 (66.3)	250 (56.2)	1.5 (13.3)	15 (132.8)	3 (26.6)	300 (67.4)	17 (.67)
<b>OSP-P32</b>	483 (108.6)	420 (94.4)	3 (26.6)	30 (265.5)	5 (44.3)	450 (101.2)	20 (.79)
<b>OSP-P40</b>	754 (169.5)	640 (143.9)	6 (53.1)	60 (531)	8 (70.8)	750 (168.6)	27 (1.06)
<b>OSP-P50</b>	1178 (264.8)	1000 (224.8)	10 (88.5)	115 (1017.8)	15 (132.8)	1200 (269.8)	30 (1.18)
<b>OSP-P63</b>	1870 (420.4)	1550 (348.5)	12 (106.2)	200 (1771)	24 (212.4)	1650 (370.9)	32 (1.26)
<b>OSP-P80</b>	3016 (678)	2600 (584.5)	24 (212.4)	360 (3186)	48 (424.8)	2400 (539.5)	39 (1.54)

\* A rubber element (non-adjustable) is used for end cushioning. To deform the rubber element enough to reach the absolute end position would require a  $\Delta p$  of 4 bar!

**Cushioning diagram**

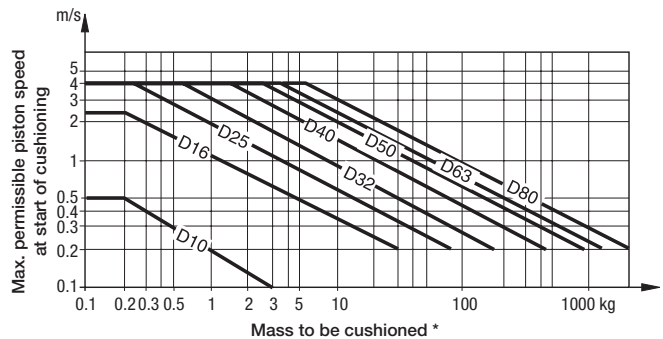
Determine the moving mass and follow the chart below to determine the maximum cylinder velocity.

Alternatively, take your desired velocity and moving mass to determine the required cylinder diameter.

If these maximum permissible values are exceeded, additional shock absorbers must be used.

For sizing a basic cylinder, use the adjacent chart. To size a cylinder with guide bearing, use the charts on the following page.

The peak piston velocity can be determined by assuming it is 50% greater than the average velocity. The peak velocity should be used in sizing the cylinder cushions.



Includes piston mass.

\* For cylinders with linear guides or brakes, please be sure to take the mass of the carriage or the brake housing into account.

**G**  
 Rodless Pneumatic Cylinders  
 OSP-P Series  
 P1X Series  
 P1Z Series  
 GDL Series

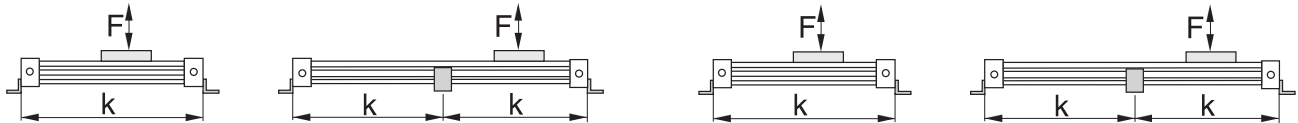


For inventory, lead times, and kit lookup, visit [www.pdnplu.com](http://www.pdnplu.com)

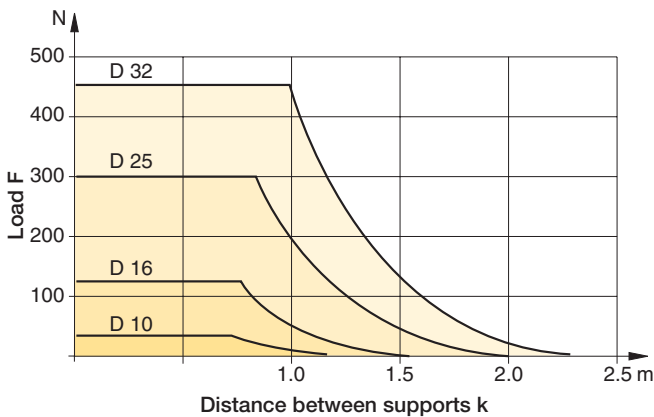
**Mid-Section Supports**

To avoid excessive bending and oscillation of the cylinder, intermediate supports may be required. The diagrams below show the maximum permissible support spacing based upon load.

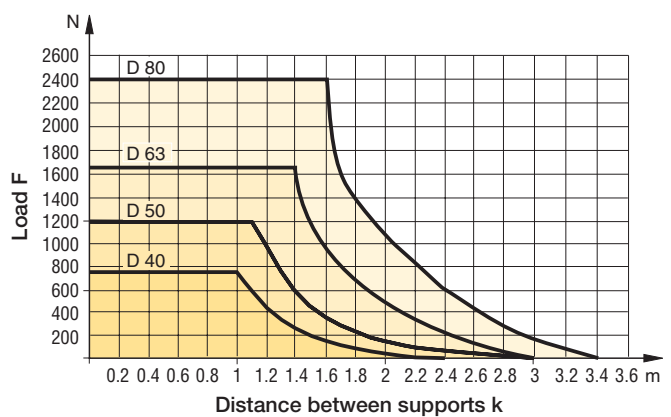
Bending up to 0.5 mm is permissible between supports. The mid-section supports are clamped on to the dovetail profile of the cylinder tube. They are also able to take the axial forces.



**Basic cylinder 10 to 32mm bore  
mid-section supports**



**Basic cylinder 40 to 80mm bore  
mid-section supports**



Rodless Pneumatic Cylinders

OSP-P Series

P1X Series

P1Z Series

GDL Series



For inventory, lead time, and kit lookup, visit [www.pdnplu.com](http://www.pdnplu.com)

**Cylinder Stroke and Dead Length A**

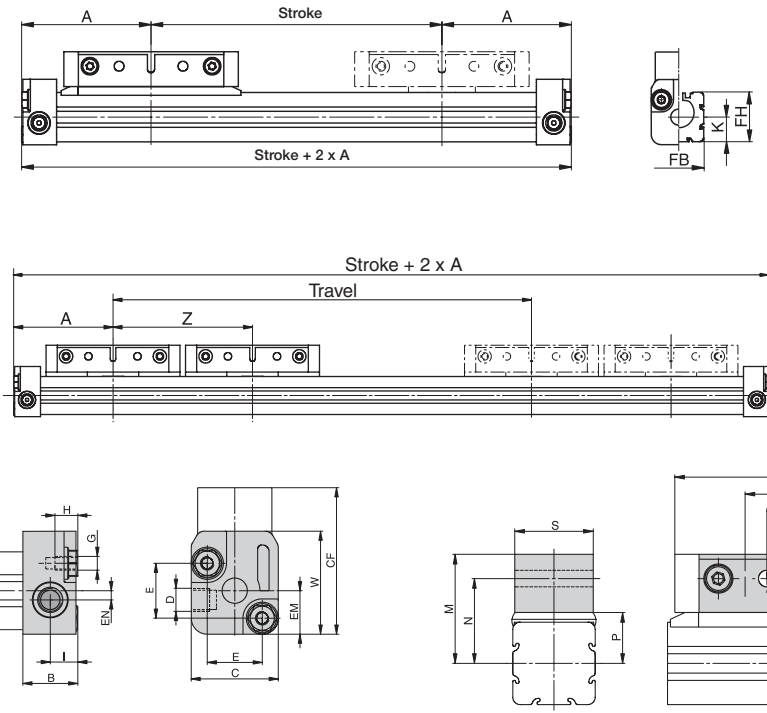
- Free choice of stroke length up to 5500mm in 1mm steps.
- Longer strokes available on request.

**Tandem Cylinder**

- Two pistons are fitted : dimension "Z" is optional. Please note minimum distance "Zmin".
- Free choice of stroke length up to 5500mm in 1mm steps.
  - Longer strokes available on request.
  - Stroke length to order is stroke + dimension "Z".

**Please note:**  
**To avoid multiple actuation of magnetic switches, the second piston is not equipped with magnets.**

**Basic cylinder – 10mm bore**



**Dimensions (mm)**

Series	A	B	C	D	E	G	H	I	J	K	L	M	N	P	R	S	W	X	Y	Zmin	CF	EM	EN	FB	FH	ZZ
OSP-P10	44.5	12	19	M5	12	M3	5	6	60	8.5	22	22.5	17.5	10.5	3.4	16	22.5	31	M3	64	32	9.5	2	17	17	6

**G**  
 Rodless Pneumatic  
 Cylinders  
 OSP-P  
 Series  
 P1X  
 Series  
 P1Z  
 Series  
 GDL  
 Series



For inventory, lead times, and kit lookup, visit [www.pdnplu.com](http://www.pdnplu.com)

**Cylinder Stroke and Dead Length A**

- Free choice of stroke length up to 5500mm in 1mm steps.
- Longer strokes available on request.

**Tandem Cylinder**

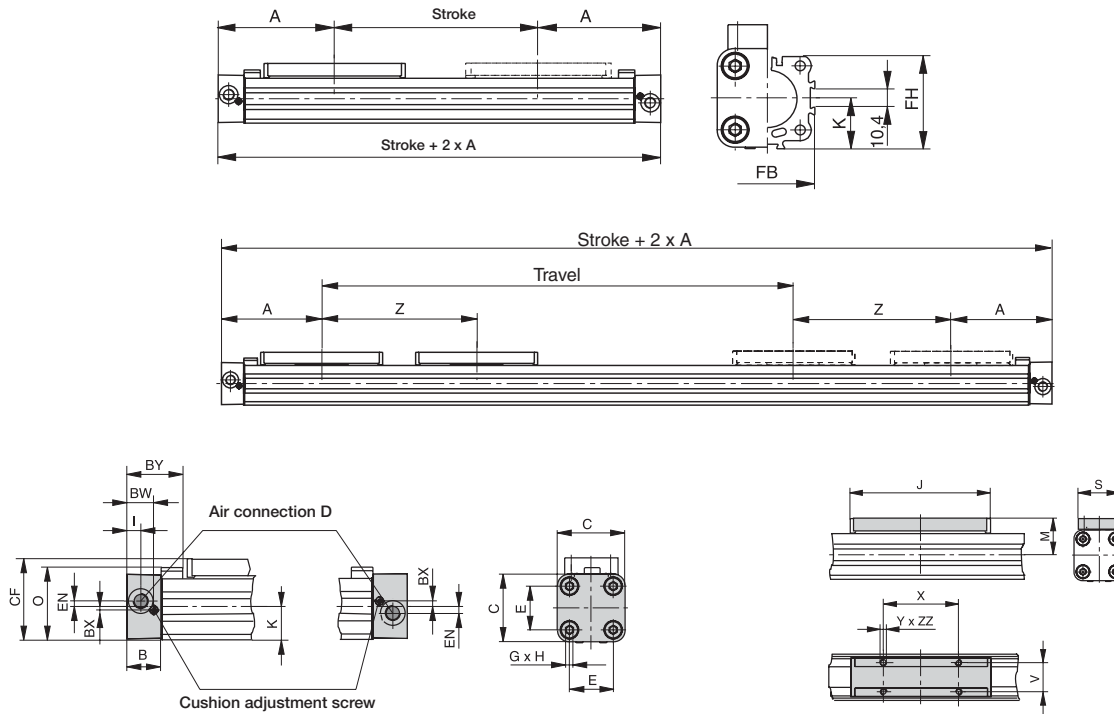
Two pistons are fitted : dimension "Z" is optional. Please note minimum distance "Zmin".

- Free choice of stroke length up to 5500mm in 1mm steps.
- Longer strokes available on request.
- Stroke length to order is stroke + dimension "Z".

**Please note:**

**To avoid multiple actuation of magnetic switches, the second piston is not equipped with magnets.**

**Basic cylinder – 16 to 80mm bore**



**Dimensions (mm)**

Series	A	B	C	D	E	G	H	I	J	K	M	O	S	V	X	Y	Z	BW	BX	BY	CF	EN	FB	FH	ZZ
OSP-P16	65	14	30	M5	18	M3	9	5.5	69	15	23	33.2	22	16.5	36	M4	81	10.8	1.8	28.4	38	3	30	27.2	7
OSP-P25	100	22	41	G1/8	27	M5	15	9	117	21.5	31	47	33	25	65	M5	128	17.5	2.2	40	52.5	3.6	40	39.5	8
OSP-P32	125	25.5	52	G1/4	36	M6	15	11.5	152	28.5	38	59	36	27	90	M6	170	20.5	2.5	44	66.5	5.5	52	51.7	1
OSP-P40	150	28	69	G1/4	54	M6	15	12	152	34	44	72	36	27	90	M6	212	21	3	54	78.5	7.5	62	63	10
OSP-P50	175	33	87	G1/4	70	M6	15	14.5	200	43	49	86	36	27	110	M6	251	27	-	59	92.5	11	76	77	10
OSP-P63	215	38	106	G3/8	78	M8	21	14.5	256	54	63	107	50	34	140	M8	313	30	-	64	117	12	96	96	16
OSP-P80	260	47	132	G1/2	96	M10	25	22	348	67	80	133	52	36	190	M10	384	37.5	-	73	147	16.5	122	122	20

**G**  
 Rodless Pneumatic Cylinders  
 OSP-P Series  
 P1X Series  
 P1Z Series  
 GDL Series



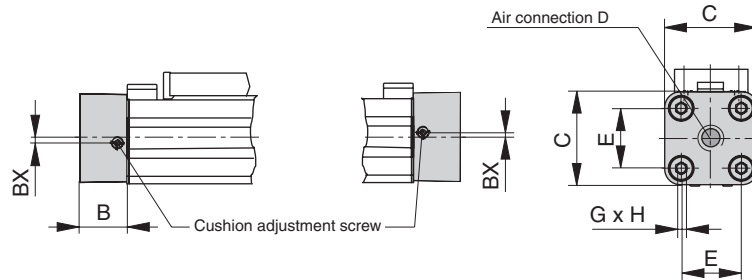
For inventory, lead time, and kit lookup, visit [www.pdnplu.com](http://www.pdnplu.com)

**Air Connection on the End-Face #5**

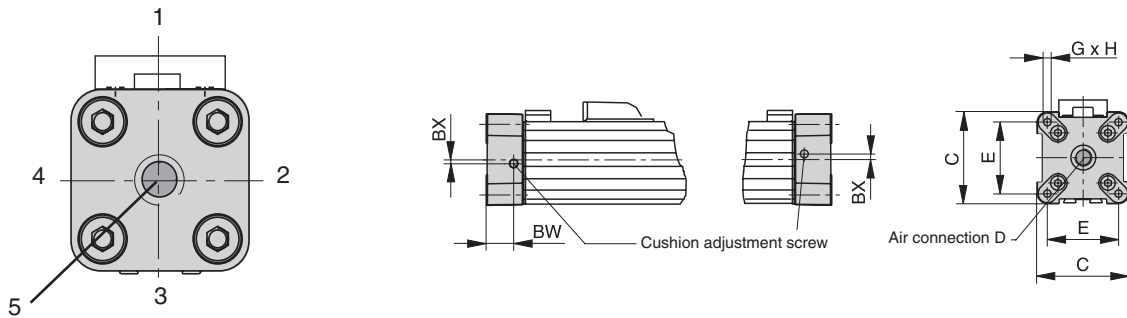
In some situations it is necessary or desirable to fit a special end cap with the air connection on the end-face instead of the standard end cap with the air connection on the side. The special end cap can also be rotated 4 x 90° to locate the cushion adjustment screw as desired.



**Series OSP-P16 to P32**



**Series OSP-P40 to P80**



**Note: Position #2 is the standard location.**

**Dimension (mm)**

Series	B	C	D	E	G	H	BX	BW
OSP-P16	14	30	M5	18	M3	9	1.8	10.8
OSP-P25	22	41	G1/8	27	M5	15	2.2	17.5
OSP-P32	25.5	52	G1/4	36	M6	15	2.5	20.5
OSP-P40	28	69	G1/4	54	M6	15	3	21
OSP-P50	33	87	G1/4	70	M6	15	-	27
OSP-P63	38	106	G3/8	78	M8	21	-	30
OSP-P80	47	132	G1/2	96	M10	25	-	37.5

G	Rodless Pneumatic Cylinders
	OSP-P Series
P1X Series	
P1Z Series	
GDL Series	



For inventory, lead times, and kit lookup, visit [www.pdnplu.com](http://www.pdnplu.com)



**Single End Porting**

A special end cap with both air connections on one side is available for situations where shortage of space, simplicity of installation or the nature of the process make it desirable. Air supply to the other end is via internal air passages (OSP-P25 to P80) or via a hollow aluminum profile fitted externally (OSP-P16).

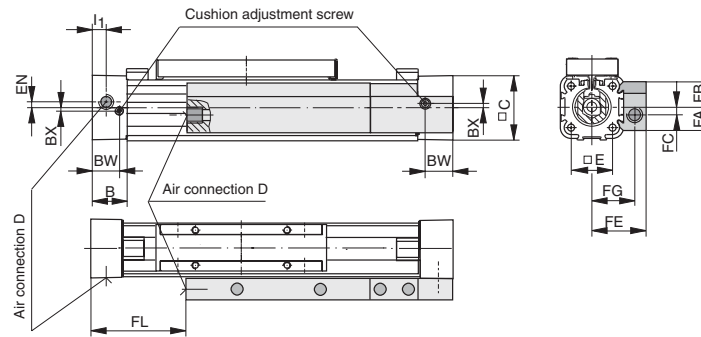
In this case the end caps cannot be rotated.

Please note:

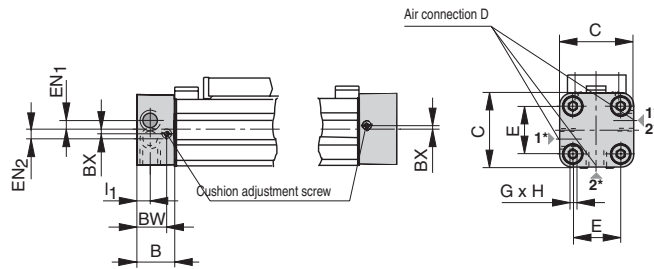
When combining the OSP-P16 single end porting with inversion mountings, RS magnetic switches can only be mounted directly opposite to the external air-supply profile.



**Series OSP-P16**

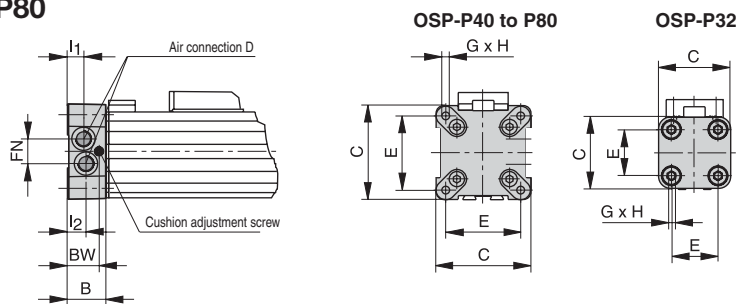


**Series OSP-P25**



\* Versions of Air Connection  
 Positions: 1 → 1 or  
 2 → 2

**Series OSP-P32 to P80**



**Dimension (mm)**

Series	B	C	D	E	G	H	I1	I2	BX	BW	EN	EN1	EN2	FA	FB	FC	FE	FG	FL	FN
OSP-P16	14	30	M5	18	M3	9	5.5	-	1.8	10.8	3	-	-	12.6	12.6	4	27	21	36	-
OSP-P25	22	41	G1/8	27	M5	15	9	-	2.2	17.5	-	3.6	3.9	-	-	-	-	-	-	-
OSP-P32	25.5	52	G1/8	36	M6	15	12.2	10.5	-	20.5	-	-	-	-	-	-	-	-	-	15.2
OSP-P40	28	69	G1/8	54	M6	15	12	12	-	21	-	-	-	-	-	-	-	-	-	17
OSP-P50	33	87	G1/4	70	M6	15	14.5	14.5	-	-	-	-	-	-	-	-	-	-	-	22
OSP-P63	38	106	G3/8	78	M8	21	16.5	13.5	-	30	-	-	-	-	-	-	-	-	-	25
OSP-P80	47	132	G1/2	96	M10	25	22	17	-	37.5	-	-	-	-	-	-	-	-	-	34.5



For inventory, lead time, and kit lookup, visit [www.pdnplu.com](http://www.pdnplu.com)

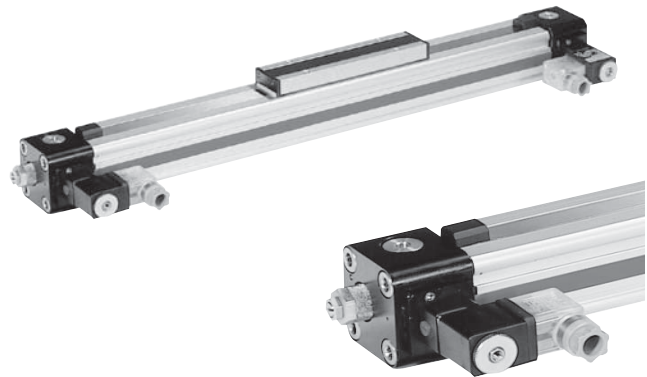
**Integrated 3/2 Way Valves VOE Series OSP-P25, P32, P40 and P50**

For optimal control of the OSP-P cylinder, 3/2 way valves integrated into the cylinder's end caps can be used as a compact and complete solution.

They allow for easy positioning of the cylinder, smooth operation at the lowest speeds and fast response, making them ideally suited for the direct control of production and automation processes.

**Characteristics:**

- Complete compact solution
- Various connection possibilities:  
Free choice of air connection with rotating end caps with VOE valves, Air connection can be rotated 4 x 90°, Solenoid can be rotated 4 x 90°, Pilot Valve can be rotated 180°
- High piston velocities can be achieved with max. 3 exhaust ports
- Minimal installation requirements
- Requires just one air connection per valve
- Optimal control of the OSP-P cylinder
- Excellent positioning characteristics
- Integrated operation indicator
- Integrated exhaust throttle valve
- Manual override - indexed
- Adjustable end cushioning
- Easily retrofitted – please note the increase in the overall length of the cylinder!

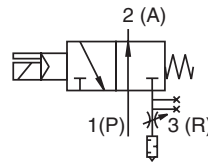


Operating information	
Operating pressure:	116 PSIG (8 bar)
Temperature range:	-14°F to 122°F (10°C to 50°C)
Filtration requirements:	Filtered, nonlubricated compressed air

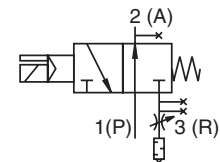
**Specifications**

- Characteristics 3/2 Way Valves with spring return
- Actuation electrical
- Basic position P → A open, R closed
- Type Poppet valve, non overlapping
- Mounting integrated in end cap
- Installation in any position
- Port size G 1/8 VOE-25 G 1/4 VOE-32  
G 3/8 VOE-40 G 3/8 VOE-50
- Temperature -10°C to 50°C \*
- Operating pressure 2-8 bar
- Nominal voltage 24 V DC / 230 V AC, 50 Hz
- Power consumption 2,5 W / 6 VA
- Duty cycle 100%
- Electrical Protection IP65 DIN 40050

\* Other temperature ranges on request



**VOE-25 / VOE-32**



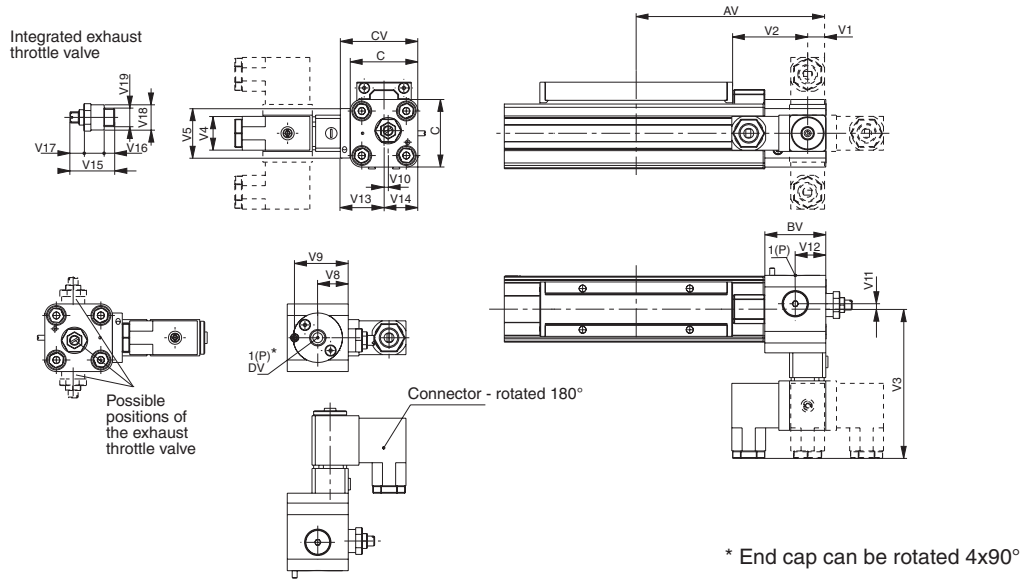
**VOE-40 / VOE-50**

**G**  
 Rodless Pneumatic Cylinders  
 OSP-P Series  
 P1X Series  
 P1Z Series  
 GDL Series



For inventory, lead times, and kit lookup, visit [www.pdnplu.com](http://www.pdnplu.com)

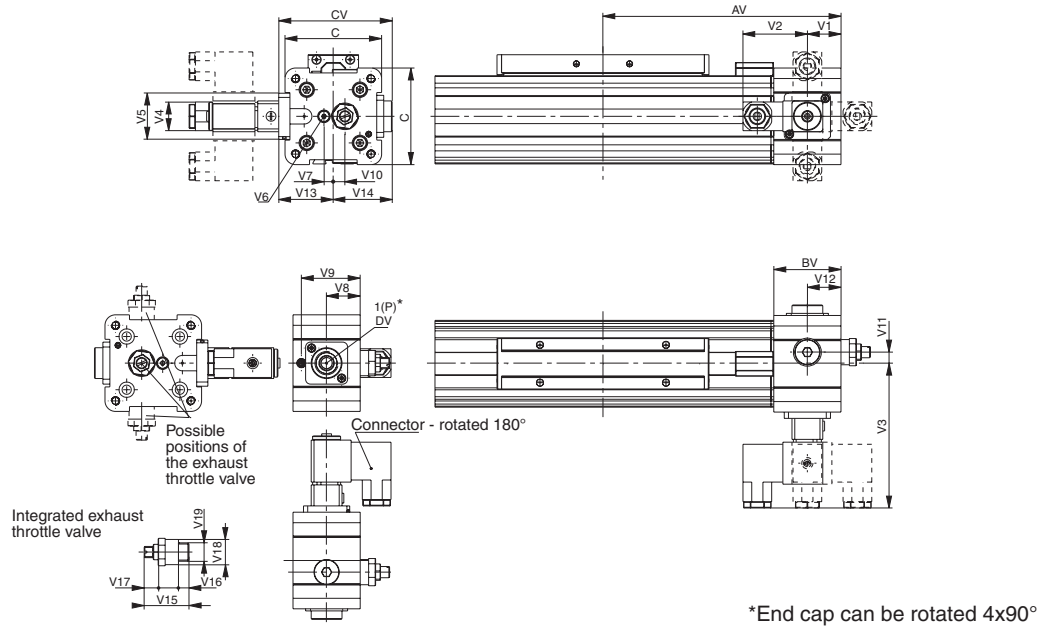
**Dimensions VOE Valves OSP-P25 and P32**



**Dimension (mm)**

Series	AV	BV	C	CV	DV	V1	V2	V3	V4	V5	V8	V9	V10	V11	V12	V13	V14	V15	V16	V17	V18	V19
OSP-P25	115	37	41	47	G1/8	11	46	90.5	22	30	18.5	32.5	2.5	3.3	18.5	26.5	20.5	24	5	4	14	G1/8
OSP-P32	139	39.5	52	58	G1/4	20.5	46	96	22	32	20.5	34.7	6	5	20.5	32	26	32	7.5	6	18	G1/4

**Dimensions VOE Valves OSP-P40 and P50**



**Dimension (mm)**

Series	AV	BV	C	CV	DV	V1	V2	V3	V4	V5	V6	V7	V8	V9	V10	V11	V12	V13	V14	V15	V16	V17	V18	V19
OSP-P40	170	48	69	81	G3/8	24	46	103	22	33	M5	6.7	24	42	8.3	8.3	24	39	42	32	7.5	6	18	G1/4
OSP-P50	190	48	87	82	G3/8	24	46	102	22	33	M5	4.5	24	42	12.2	12.2	24	38	44	32	7.5	6	18	G1/4



Rodless Pneumatic Cylinders

OSP-P Series

P1X Series

P1Z Series

GDL Series



For inventory, lead time, and kit lookup, visit [www.pdnplu.com](http://www.pdnplu.com)

G21

**Parker Hannifin Corporation**  
 Pneumatic Division  
 Richland, Michigan  
[www.parker.com/pneumatics](http://www.parker.com/pneumatics)

**Active Brake**

**Series AB 25 to 80 for linear drive**

- Series OSP-P
- Can be used with Sensoflex

**Features:**

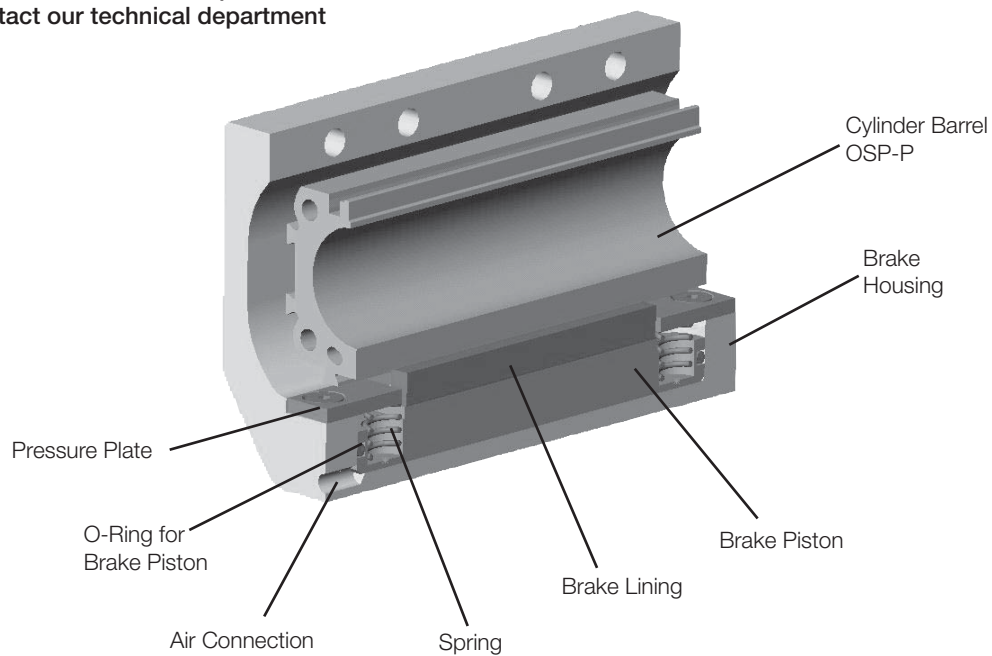
- Actuated by pressurization
- Released by spring actuation
- Completely stainless version
- Holds position, even under changing load conditions



For further technical data, please refer to the data sheets for linear drives OSP-P (page G10)

**Note:**

For combinations Active Brake AB + SFI-plus + Magnetic Switch contact our technical department please.



**Forces and Weights**

Series	For linear drive	Max. braking force (N) †	Brake pad way (mm)	Mass (kg)			Part number Active brake (includes carriage)	
				Linear drive with brake		Brake*		
				0 mm stroke	increase per 100mm stroke			
Series P1X	AB 25	OSP-P25	350	2.5	1.0	0.197	0.35	20806FIL
	AB 32	OSP-P32	590	2.5	2.02	0.354	0.58	20807FIL
	AB 40	OSP-P40	900	2.5	2.83	0.415	0.88	20808FIL
Series P1Z	AB 50	OSP-P50	1400	2.5	5.03	0.566	1.50	20809FIL
	AB 63	OSP-P63	2170	3.0	9.45	0.925	3.04	20810FIL
	AB 80	OSP-P80	4000	3.0	18.28	1.262	5.82	20811FIL

† – at 6 bar both chambers pressurized with 6 bar Braking surface dry  
 – oil on the braking surface will reduce the braking force

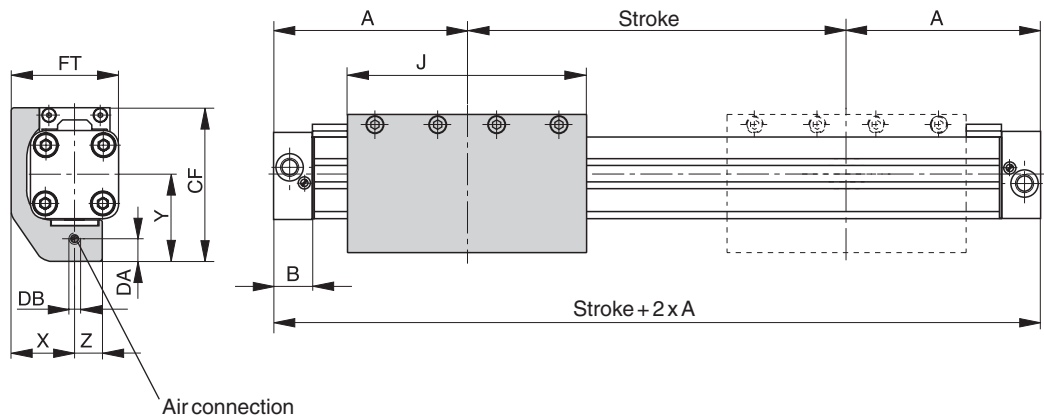
\* **Please Note:**  
 The mass of the brake has to be added to the total moving mass when using the cushioning diagram.

**G**  
 Rodless Pneumatic Cylinders  
 OSP-P Series  
 P1X Series  
 P1Z Series  
 GD L Series

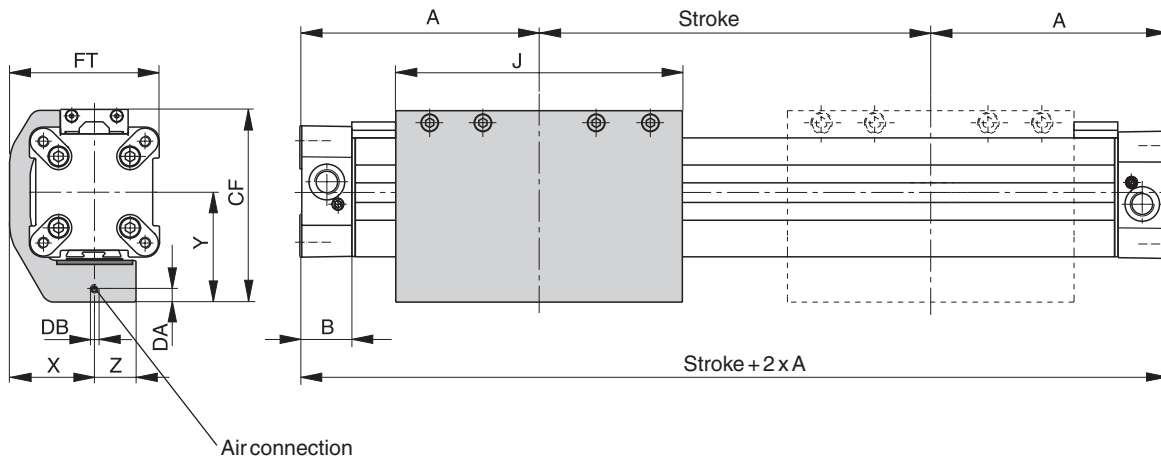


For inventory, lead times, and kit lookup, visit [www.pdnplu.com](http://www.pdnplu.com)

**Series OSP-P25 and P32 with Active Brake AB**



**Series OSP-P40, P50, P63, P80 with Active Brake AB**



**Dimension (mm)**

Series	A	B	J	X	Y	Z	CF	DA	DB	FT
AB 25	100	22	117	29.5	43	13	74	4	M5	50
AB 32	125	25.5	151.4	36	50	15	88	4	M5	62
AB 40	150	28	151.4	45	58	22	102	7	M5	79.5
AB 50	175	33	200	54	69.5	23	118.5	7.5	M5	97.5
AB 63	215	38	256	67	88	28	151	9	G1/8	120
AB 80	260	47	348	83	105	32	185	10	G1/8	149

**G**  
**Rodless Pneumatic Cylinders**  
**OSP-P Series**  
**P1X Series**  
**P1Z Series**  
**GDL Series**



For inventory, lead time, and kit lookup, visit [www.pdnplu.com](http://www.pdnplu.com)

G23

**Parker Hannifin Corporation**  
 Pneumatic Division  
 Richland, Michigan  
[www.parker.com/pneumatics](http://www.parker.com/pneumatics)

**End Cap Mountings**

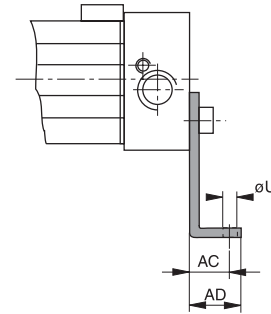
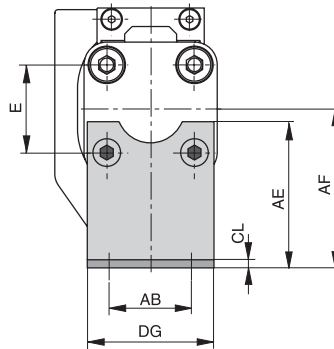
On the end-face of each cylinder end cap there are four threaded holes for mounting the cylinder. The hole layout is square, so that the mounting can be fitted to the bottom, top or either side.

**Series OSP – P25 and P32 with Active Brake AB: Type A3**

**Material:**

Galvanized steel

The mountings are supplied in pairs.



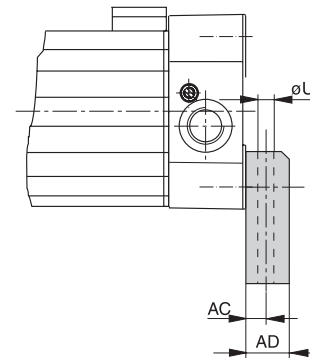
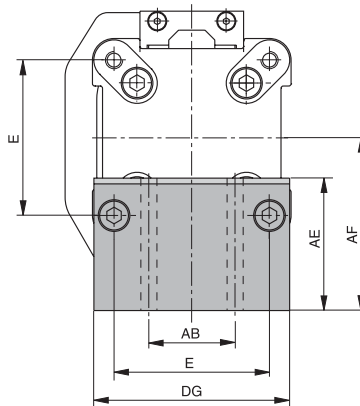
**Series OSP – P40 , P50, P63, P80 with Active Brake AB: Type C3**

**Material:**

Anodized aluminum

The mountings are supplied in pairs.

Stainless steel version on request.



**Dimension (mm)**

Series	E	øU	AB	AC	AD	AE	AF	CL	DG	Part number	
										Type A3	Type C3
AB 25	27	5.8	27	16	22	45	49	2.5	39	2060FIL	-
AB 32	36	6.6	36	18	26	42	52	3	50	3060FIL	-
AB 40	54	9	30	12.5	24	46	60	-	68	-	20339FIL
AB 50	70	9	40	12.5	24	54	72	-	86	-	20350FIL
AB 63	78	11	48	15	30	76	93	-	104	-	20821FIL
AB 80	96	14	60	17.5	35	88	110	-	130	-	20822FIL

**G**  
 Rodless Pneumatic Cylinders  
 OSP-P Series  
 P1X Series  
 P1Z Series  
 GDL Series



For inventory, lead times, and kit lookup, visit [www.pdnplu.com](http://www.pdnplu.com)

**Mid-Section Supports**

Mid-section supports are required from a certain stroke length to prevent excessive deflection and vibration of the linear drive.

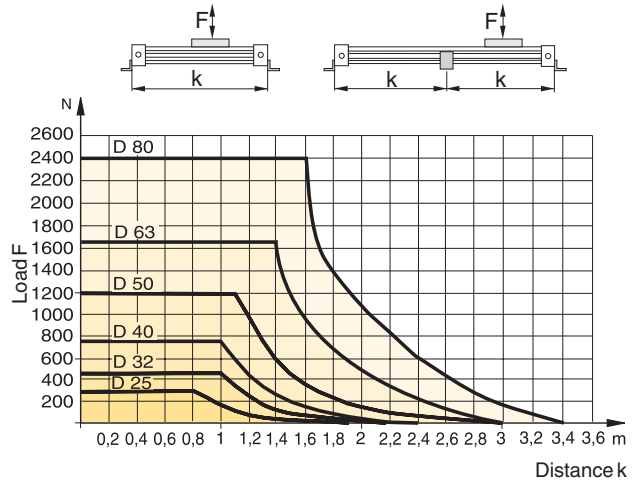
The diagrams show the maximum permissible unsupported length in relation to loading. Deflection of 0.5mm max. between supports is permissible.

The Mid-Section supports are attached to the dovetail rails, and can take axial loads.

**Note to Type E3:**

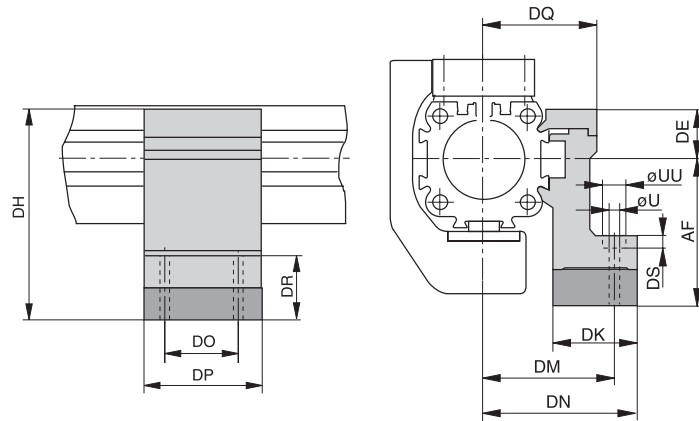
Mid-Section supports can only be mounted opposite of the brake housing.

Stainless steel version available on request.



**Series OSP-P25 to P80 with Active Brake AB: Type E3**

(Mounting from above / below with through-bolt)



**Dimension (mm)**

Series	U	UU	AF	DE	DH	DK	DM	DN	DO	DP	DQ	DR	DS	Type E3 part number
AB 25	5.5	10	49	16	65	26	40	47.5	36	50	34.5	35	5.7	20353FIL
AB 32	5.5	10	52	16	68	27	46	54.5	36	50	40.5	32	5.7	20356FIL
AB 40	7	-	60	23	83	34	53	60	45	60	45	32	-	20359FIL
AB 50	7	-	72	23	95	34	59	67	45	60	52	31	-	20362FIL
AB 63	9	-	93	34	127	44	73	83	45	65	63	48	-	20453FIL
AB 80	11	-	110	39.5	149.5	63	97	112	55	80	81	53	-	20819FIL

**Accessories for linear drives with Active Brakes – please order separately**

Description	For detailed information, see page no.
Clevis mounting	F27
Adaptor profile	F31
T-groove profile	F32
Connection profile	F33
Magnetic switch (can only be mounted opposite of the brake housing)	F87-F92
Incremental displacement measuring system SFI-plus	F95-F97



For inventory, lead time, and kit lookup, visit [www.pdnplu.com](http://www.pdnplu.com)

G25

**Parker Hannifin Corporation**  
 Pneumatic Division  
 Richland, Michigan  
[www.parker.com/pneumatics](http://www.parker.com/pneumatics)

**Clevis Mount  $\varnothing$  10mm**

**For Linear-drive**

- Series OSP-P

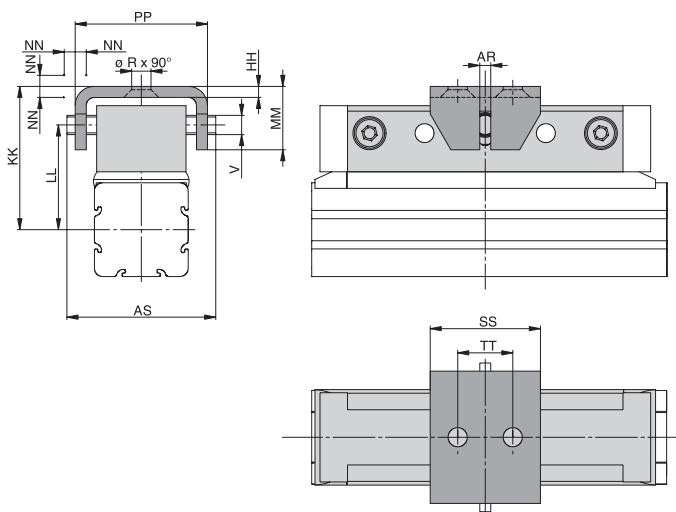
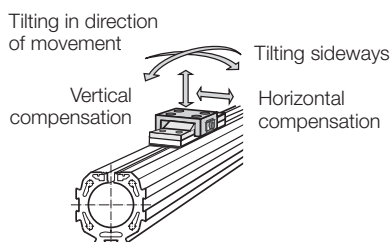
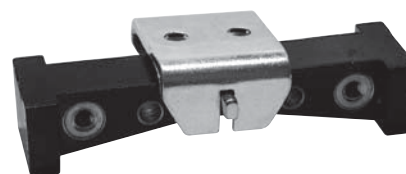


When external guides are used, parallelism deviations can lead to mechanical strain on the piston. This can be avoided by the use of a clevis mounting.

In the drive direction, the mounting has very little play.

Freedom of movement is provided as follows:

- Tilting in direction of movement
- Vertical compensation
- Tilting sideways
- Horizontal compensation



**Dimension (mm)**

Series	$\varnothing$ R	V	AR	AS	HH	KK	LL	MM	NN*	PP	SS	TT	Part number	
													Standard	Stainless
OSP-P10	3.4	3.5	2	27	2	26	19	11.5	1	24	20	10	20971FIL	-

\* Dimension NN gives the possible plus and minus play in horizontal and vertical movement, which also makes tilting sideways possible.



**Clevis Mount  $\varnothing$  16 to 80mm**

**For Linear-drive**

- Series OSP-P

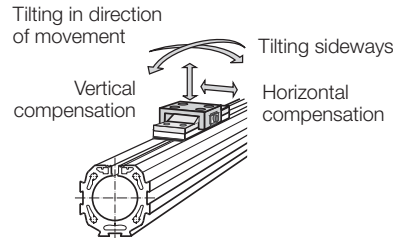
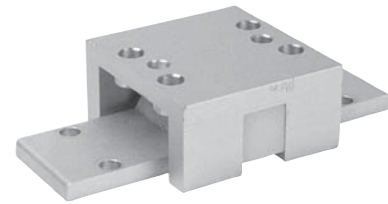
When external guides are used, parallelism deviations can lead to mechanical strain on the piston. This can be avoided by the use of a clevis mounting.

In the drive direction, the mounting has very little play.

Freedom of movement is provided as follows:

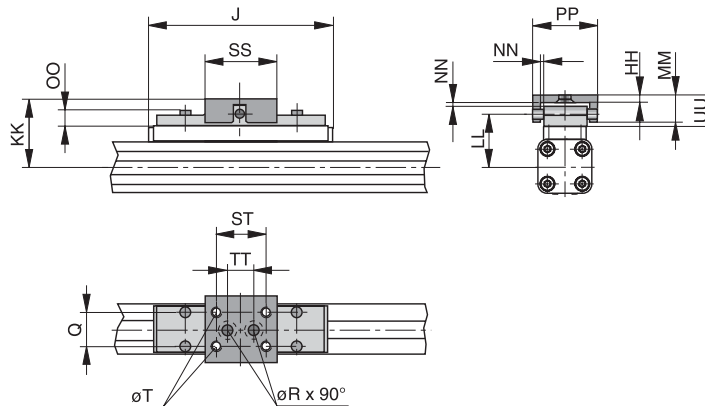
- Tilting in direction of movement
- Vertical compensation
- Tilting sideways
- Horizontal compensation

A stainless steel version is also available.

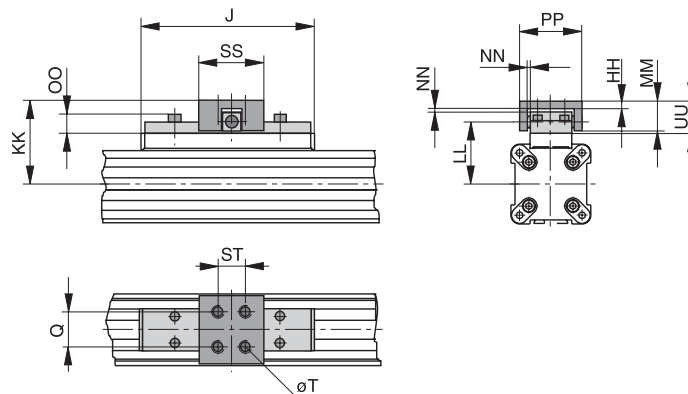


**Please note:**  
When using additional inversion mountings, take into account the dimensions in page G28.

**Series OSP-P16 to 32**



**Series OSP-P40 to 80**



Dimension (mm)

Series	J	Q	T	$\varnothing R$	HH	KK	LL	MM	NN*	OO	PP	SS	ST	TT	UU	Part number	
																Standard	Stainless
OSP-P16	69	10	M4	4.5	3	34	26.6	10	1	8.5	26	28	20	10	11	20462FIL	20463FIL
OSP-P25	117	16	M5	5.5	3.5	52	39	19	2	9	38	40	30	16	21	20005FIL	20092FIL
OSP-P32	152	25	M6	6.6	6	68	50	28	2	13	62	60	46	40	30	20096FIL	20094FIL
OSP-P40	152	25	M6	-	6	74	56	28	2	13	62	60	46	-	30	20024FIL	20093FIL
OSP-P50	200	25	M6	-	6	79	61	28	2	13	62	60	46	-	30	20097FIL	20095FIL
OSP-P63	256	37	M8	-	8	100	76	34	3	17	80	80	65	-	37	20466FIL	20467FIL
OSP-P80	348	38	M10	-	8	122	96	42	3	16	88	90	70	-	42	20477FIL	20478FIL

\* Dimension NN gives the possible plus and minus play in horizontal and vertical movement, which also makes tilting sideways possible.



For inventory, lead time, and kit lookup, visit [www.pdnplu.com](http://www.pdnplu.com)

G27

**Parker Hannifin Corporation**  
Pneumatic Division  
Richland, Michigan  
[www.parker.com/pneumatics](http://www.parker.com/pneumatics)

**Inversion Mount ø 16 to 80mm**

For Linear-drive

- Series OSP-P



In dirty environments, or where there are special space problems, inversion of the cylinder is recommended.

The inversion bracket transfers the driving force to the opposite side of the cylinder. The size and position of the mounting holes are the same as on the standard cylinder.

**Please note:**

Other components of the OSP system such as mid-section supports, magnetic switches and the external air passage for the P16, can still be mounted on the free side of the cylinder.

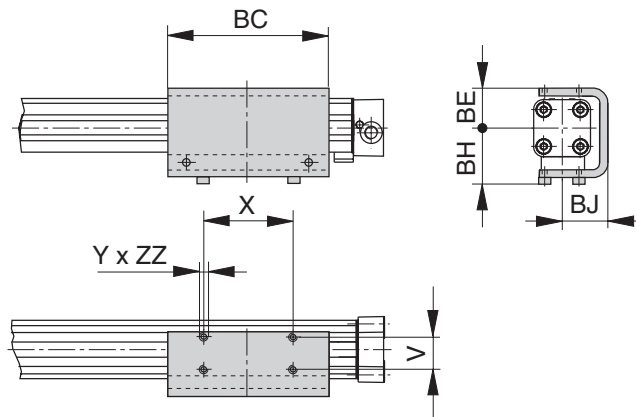
When combining single end porting with inversion mountings,

RS magnetic switches can only be mounted directly opposite to the external air-supply profile.

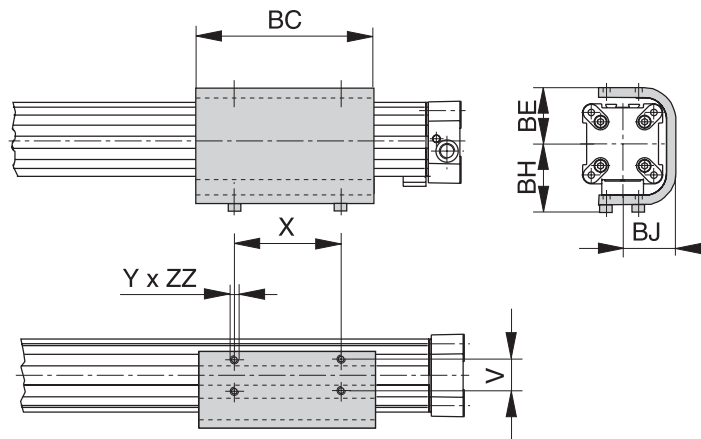
**Important Note:**

May be used in combination with Clevis Mounting, reference dimensions in pages G32-G33.

**Series OSP-P16 to 32**



**Series OSP-P40 to 80**



**Dimension (mm)**

Series	V	X	Y	BC	BE	BH	BJ	ZZ	Part number
OSP-P16	16.5	36	M4	69	23	33	25	4	20446FIL
OSP-P25	25	65	M5	117	31	44	33.5	6	20037FIL
OSP-P32	27	90	M6	150	38	52	39.5	6	20161FIL
OSP-P40	27	90	M6	150	46	60	45	8	20039FIL
OSP-P50	27	110	M6	200	55	65	52	8	20166FIL
OSP-P63	34	140	M8	255	68	83.5	64	10	20459FIL
OSP-P80	36	190	M10	347	88	107.5	82	15	20490FIL

**G**  
 Rodless Pneumatic Cylinders  
 OSP-P Series  
 P1X Series  
 P1Z Series  
 GDL Series



For inventory, lead times, and kit lookup, visit [www.pdnplu.com](http://www.pdnplu.com)

**End Cap Mounting  $\varnothing$  10 to 80mm**

**For Linear-drive**

- Series OSP-P



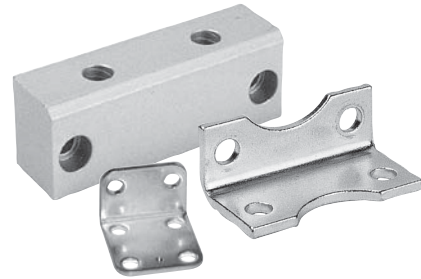
On the end-face of each end cap there are four threaded holes for mounting the actuator.

The hole layout is square, so that the mounting can be fitted to the bottom, top or either side, regardless of the position chosen for the air connection.

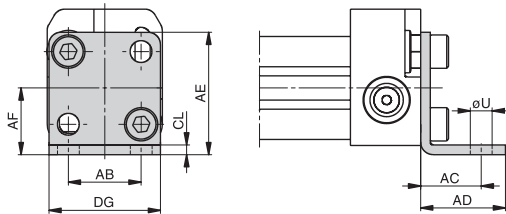
**Material:**

- Series OSP-P10 – P32: Galvanized steel.
- Series OSP-P40 – P80: Anodized aluminum.

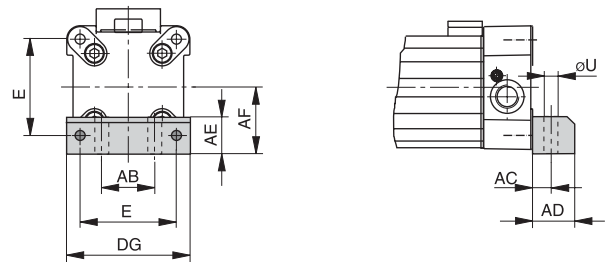
The mountings are supplied in pairs.



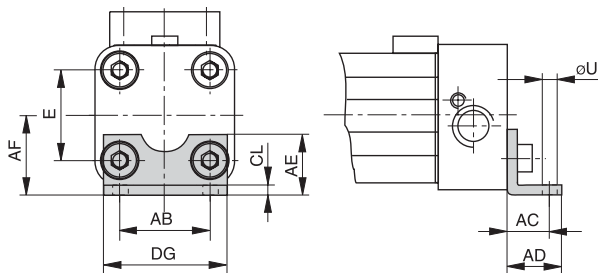
**Series OSP-P10: Type A1**



**Series OSP-P40 to 80: Type C1**



**Series OSP-P16 to 32: Type A1**



**Dimension (mm)**

Series	E	$\varnothing U$	AB	AC	AD	AE	AF	CL	DG	Part number (pair)	
										Type A1	Type C1
OSP-P10	-	3.6	12	10	14	20.2	11	1.6	18.4	0240	-
OSP-P16	18	3.6	18	10	14	12.5	15	1.6	26	20408FIL	-
OSP-P25	27	5.8	27	16	22	18	22	2.5	39	2010	-
OSP-P32	36	6.6	36	18	26	20	30	3	50	3010	-
OSP-P40	54	9	30	12.5	24	24	38	-	68	-	4010FIL
OSP-P50	70	9	40	12.5	24	30	48	-	86	-	5010FIL
OSP-P63	78	11	48	15	30	40	57	-	104	-	6010FIL
OSP-P80	96	14	60	17.5	35	50	72	-	130	-	8010FIL

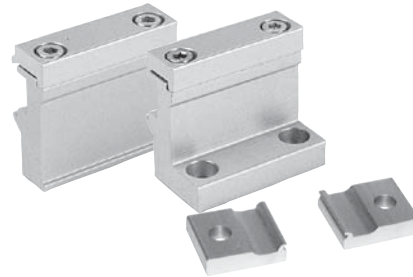


For inventory, lead time, and kit lookup, visit [www.pdnplu.com](http://www.pdnplu.com)

**Mid-Section Support ø 10 to 80mm**

For Linear-drive

- Series OSP-P



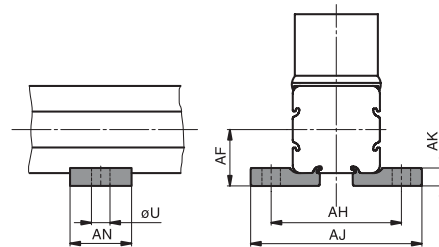
**Note on Types E1 and D1 (P16 – P80):**

The mid-section support can also be mounted on the underside of the actuator, in which case its distance from the center of the actuator is different.

Stainless steel version on demand.

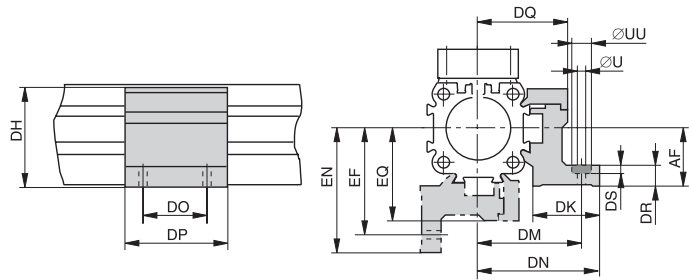
**Series OSP-10, Type E1**

(Mounting from above / below using a cap screw)



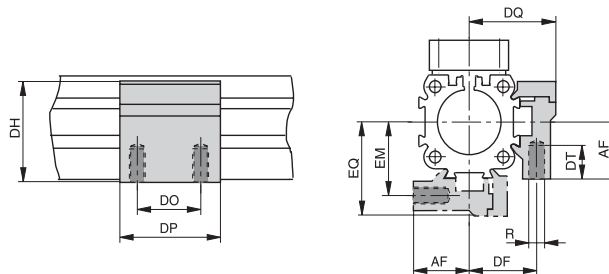
**Series OSP-P16 to P80: Type E1**

(Mounting from above / below using a cap screw)



**Series OSP-16 to 80, Type D1**

(Mountings from below with 2 screws)



**Dimension (mm)**

Series	U	AF	AH	AJ	AK	AN	Part number	
							Type E1	Type D1
OSP-P10	3.6	11	25.4	33.4	3.5	12	0250	-

Series	R	U	UU	AF	DF	DH	DK	DM	DN	DO	DP	DQ	DR	DS	DT	EF	EM	EN	EQ	Part number	
																				Type E1	Type D1
OSP-P16	M3	3.4	6	15	20	29.2	24	32	36.4	18	30	27	6	3.4	6.5	32	20	36.4	27	20435FIL	20434FIL
OSP-P25	M5	5.5	10	22	27	38	26	40	47.5	36	50	34.5	8	5.7	10	41.5	28.5	49	36	20009FIL	20008FIL
OSP-P32	M5	5.5	10	30	33	46	27	46	54.5	36	50	40.5	10	5.7	10	48.5	35.5	57	43	20158FIL	20157FIL
OSP-P40	M6	7	-	38	35	61	34	53	60	45	60	45	10	-	11	56	38	63	48	20028FIL	20027FIL
OSP-P50	M6	7	-	48	40	71	34	59	67	45	60	52	10	-	11	64	45	72	57	20163FIL	20162FIL
OSP-P63	M8	9	-	57	47.5	91	44	73	83	45	65	63	12	-	16	79	53.5	89	69	20452FIL	20451FIL
OSP-P80	M10	11	-	72	60	111.5	63	97	112	55	80	81	15	-	25	103	66	118	87	20482FIL	20480FIL

**G**  
 Rodless Pneumatic Cylinders  
 OSP-P Series  
 P1X Series  
 P1Z Series  
 GDL Series



For inventory, lead times, and kit lookup, visit [www.pdnplu.com](http://www.pdnplu.com)

G30

**Parker Hannifin Corporation**  
 Pneumatic Division  
 Richland, Michigan  
[www.parker.com/pneumatics](http://www.parker.com/pneumatics)

**Adaptor Profile  $\varnothing$  16 to 50mm**

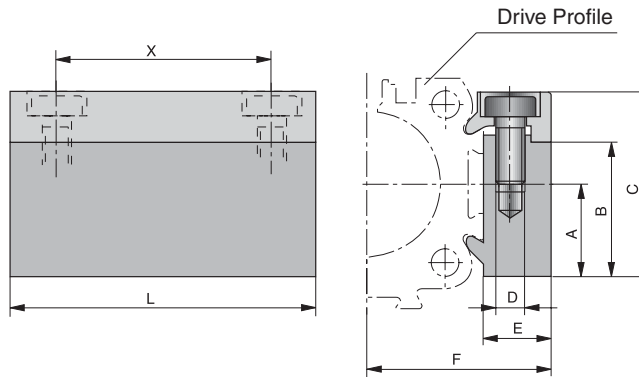
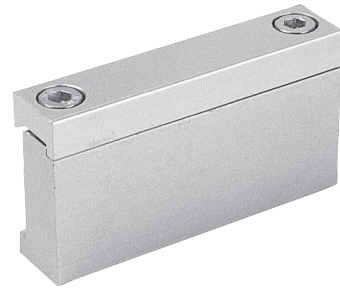
For Linear-drive

- Series OSP-P



**Adaptor Profile OSP**

- A universal attachment for mounting of valves etc.
- Solid material



**Dimension (mm)**

Series	A	B	C	D	E	F	L	X	Part number	
									Standard	Stainless
OSP-P16	14	20.5	28	M3	12	27	50	38	20432FIL	20438FIL
OSP-P25	16	23	32	M5	10.5	30.5	50	36	20006FIL	20186FIL
OSP-P32	16	23	32	M5	10.5	36.5	50	36	20006FIL	20186FIL
OSP-P40	20	33	43	M6	14	45	80	65	20025FIL	20267FIL
OSP-P50	20	33	43	M6	14	52	80	65	20025FIL	20267FIL



Rodless Pneumatic Cylinders

OSP-P Series

P1X Series

P1Z Series

GDL Series



For inventory, lead time, and kit lookup, visit [www.pdnplu.com](http://www.pdnplu.com)

G31

**Parker Hannifin Corporation**  
 Pneumatic Division  
 Richland, Michigan  
[www.parker.com/pneumatics](http://www.parker.com/pneumatics)

**T-Slot Profile  $\varnothing$  16 to 50mm**

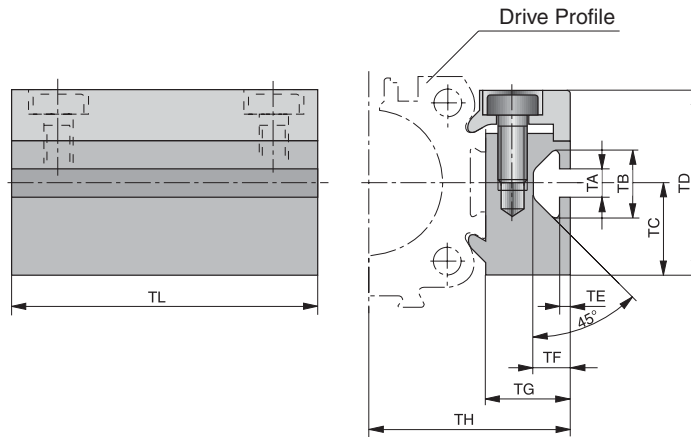
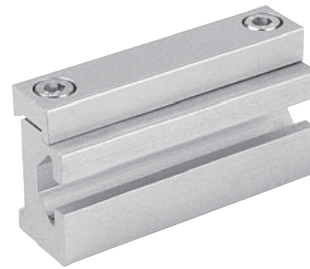
For Linear-drive

- Series OSP-P



**T-Slot Profile OSP**

- A universal attachment for mounting with standard T-Nuts



**Dimension (mm)**

Series	TA	TB	TC	TD	TE	TF	TG	TH	TL	Part number	
										Standard	Stainless
OSP-P16	5	11.5	14	28	1.8	6.4	12	27	50	20433FIL	20439FIL
OSP-P25	5	11.5	16	32	1.8	6.4	14.5	34.5	50	20007FIL	20187FIL
OSP-P32	5	11.5	16	32	1.8	6.4	14.5	40.5	50	20007FIL	20187FIL
OSP-P40	8.2	20	20	43	4.5	12.3	20	51	80	20026FIL	20268FIL
OSP-P50	8.2	20	20	43	4.5	12.3	20	58	80	20026FIL	20268FIL

**G**  
 Rodless Pneumatic Cylinders  
 OSP-P Series  
 P1X Series  
 P1Z Series  
 GDL Series



For inventory, lead times, and kit lookup, visit [www.pdnplu.com](http://www.pdnplu.com)

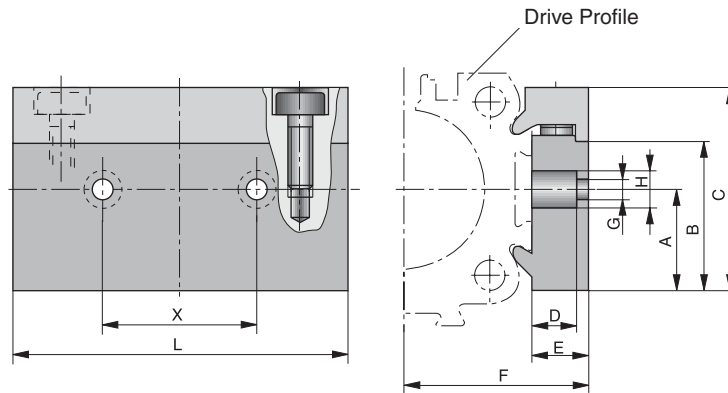
G32

**Parker Hannifin Corporation**  
 Pneumatic Division  
 Richland, Michigan  
[www.parker.com/pneumatics](http://www.parker.com/pneumatics)

**Connection Profile  $\varnothing$  16 to 50mm**

**For combining**

- Series OSP-P with system profiles
- Series OSP-P with Series OSP-P

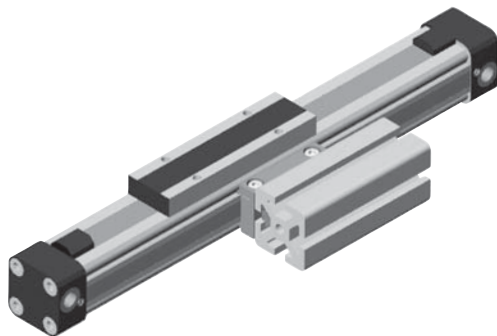


**Dimension (mm)**

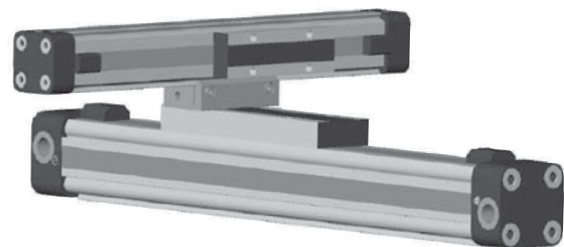
Cylinder Series	For mounting on the carrier of	A	B	C	D	E	F	G	H	L	X	Part number
OSP-P16	OSP25	14	20.5	28	8.5	12	27	5.5	10	50	25	20849FIL
OSP-P25	OSP32-50	16	23	32	8.5	10.5	30.5	6.6	11	60	27	20850FIL
OSP-P32	OSP32-50	16	23	32	8.5	10.5	36.5	6.6	11	60	27	20850FIL
OSP-P40	OSP32-50	20	33	43	8	14	45	6.6	11	60	27	20851FIL
OSP-P50	OSP32-50	20	33	43	8	14	52	6.6	11	60	27	20851FIL

**Possible Combinations**

**Combination of Series OSP-P with system profiles**



**Combination of Series OSP-P with Series OSP-P**



**G**

Rodless Pneumatic Cylinders

OSP-P Series

P1X Series

P1Z Series

GDL Series



For inventory, lead time, and kit lookup, visit [www.pdnplu.com](http://www.pdnplu.com)

G33

**Parker Hannifin Corporation**  
 Pneumatic Division  
 Richland, Michigan  
[www.parker.com/pneumatics](http://www.parker.com/pneumatics)

**Joint Clamp Connection  $\varnothing$  25 to 50mm**

For connection of cylinders of the Series OSP-P



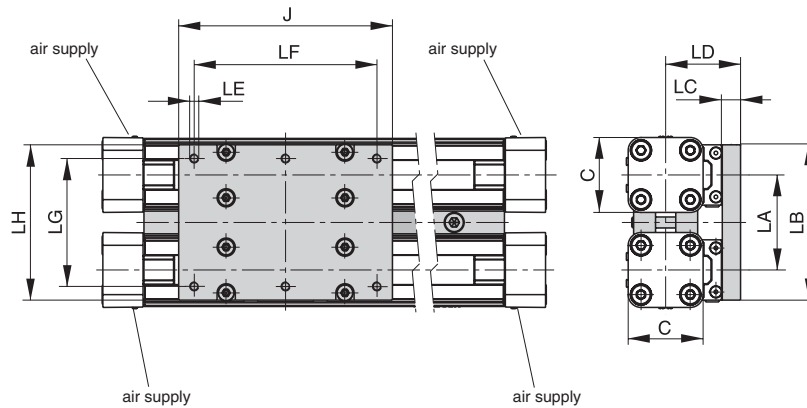
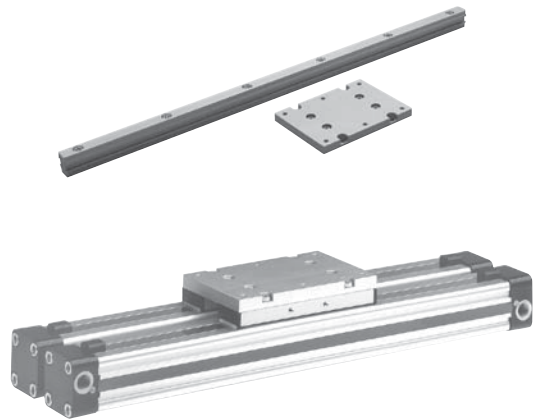
The joint clamp connection combines two OSP-P cylinders of the same size into a compact unit with high performance.

**Features**

- Increased load and torque capacity
- Higher driving forces

**Included in delivery:**

- 2 clamping profiles with screws
- 1 mounting plate with fixings



**Dimension (mm)**

Series	C	J	LA	LB	LC	LD	LE	LF	LG	LH	Part number
OSP-P25	41	117	52	86	10	41	M5	100	70	85	Consult factory
OSP-P32	52	152	64	101	12	50	M6	130	80	100	
OSP-P40	69	152	74	111	12	56	M6	130	90	110	
OSP-P50	87	200	88	125	12	61	M6	180	100	124	

**G**  
 Rodless Pneumatic Cylinders  
 OSP-P Series  
 P1X Series  
 P1Z Series  
 GDL Series



For inventory, lead times, and kit lookup, visit [www.pdnplu.com](http://www.pdnplu.com)



**Multiplex Connection  $\varnothing$  25 to 50mm**

For connection of cylinders of the Series OSP-P



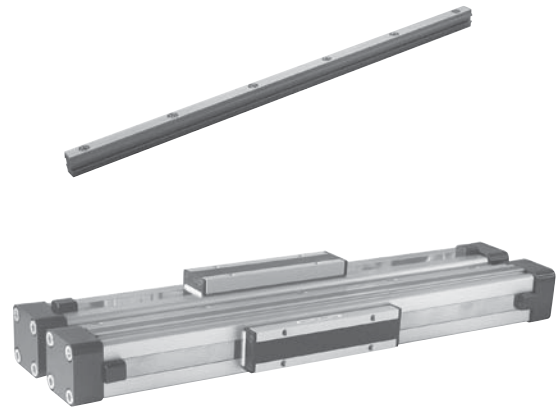
The multiplex connection combines two or more OSP-P cylinders of the same size into one unit.

**Features**

- The orientation of the carriers can be freely selected

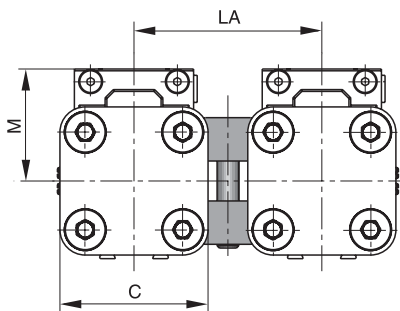
**Included in delivery:**

2 clamping profiles with clamping screws

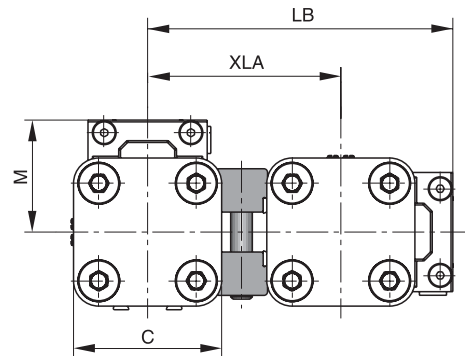


**Installation:**

Top carrier/Top carrier



Top carrier/Side carrier



**Dimension (mm)**

Series	C	M	LA	LE	XLA	Part number
OSP-P25	41	31	52	84.5	53.5	Consult factory
OSP-P32	52	38	64	104.5	66.5	
OSP-P40	69	44	74	121.5	77.5	
OSP-P50	87	49	88	142.5	93.5	



Rodless Pneumatic Cylinders

OSP-P Series

P1X Series

P1Z Series

GDL Series



For inventory, lead time, and kit lookup, visit [www.pdnplu.com](http://www.pdnplu.com)

G35

**Parker Hannifin Corporation**  
Pneumatic Division  
Richland, Michigan  
[www.parker.com/pneumatics](http://www.parker.com/pneumatics)

**Features**

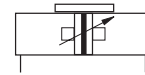
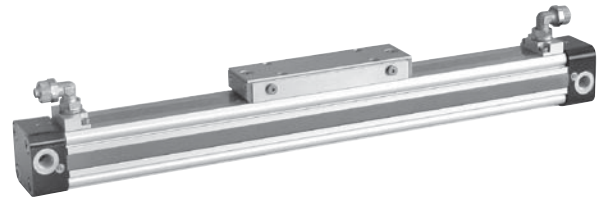
**Clean Room Cylinder ø 16 – 32 mm Rodless Cylinder certified to DIN EN ISO 14644-1**

**Standard Features:**

- Double-acting with adjustable end cushioning
- With magnetic piston for position sensing
- Clean Room classification  
 ISO Class 4 at  $v_m = 0.14$  m/s  
 ISO Class 5 at  $v_m = 0.5$  m/s
- Suitable for smooth slow speed operation up to  $v_{min} = 0.005$  m/s
- Optional stroke length up to 1200mm (longer strokes on request)
- Low maintenance
- Compact design with equal force and velocity in both directions
- Aluminum piston with bearing rings to support high direct and cantilever loads
- Stainless steel screws

**Optional Features:**

- Slow speed lubrication
- Fluorocarbon (FKM) seals



Operating information	
Operating pressure:	116 PSIG (8 bar)
Temperature range:	14°F to 176°F (10°C to 80°C)
Filtration requirements:	Filtered, nonlubricated compressed air

**Specifications**

- Type: Rodless cylinder
- Series: OSP-P
- Stroke length: 5.5m (216 inches)
- System: Double-acting, with cushioning, position sensing capability
- Mounting: See drawings
- Air connection: Threaded
- Weight (mass): See table
- Installation: In any position
- Lubrication: Prelubricated at the factory (additional oil mist lubrication not required)
- Option: special slow speed grease

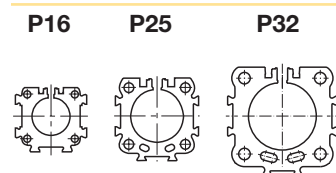
**Material specifications**

Cylinder profile	Anodized aluminum
Carrier (piston)	Anodized aluminum
End caps	Aluminum, lacquered
Sealing bands	Corrosion resistant steel
Seals	NBR (Option: Fluorocarbon)
Screws	Stainless steel
Covers	Anodized aluminum
Guide plate	Plastic

**Weight (mass) kg**

Cylinder series (Basic cylinder)	Weight (Mass) kg	
	at 0mm stroke	per 100mm stroke
OSP-P16	0.22	0.1
OSP-P25	0.65	0.197

**Size Comparison**



**G**  
 Rodless Pneumatic Cylinders  
 OSP-P Series  
 P1X Series  
 P1Z Series  
 GDL Series



For inventory, lead times, and kit lookup, visit [www.pdnplu.com](http://www.pdnplu.com)

G36

**Parker Hannifin Corporation**  
 Pneumatic Division  
 Richland, Michigan  
[www.parker.com/pneumatics](http://www.parker.com/pneumatics)

Ordering information for OSP-P rodless Clean Room pneumatic series


1-4	5-6	7	8	9	10	11	12-16	17	18	19	20	21	22	23	24	25													
<b>OSP</b>	<b>32</b>	<b>0</b>	<b>1</b>	<b>0</b>	<b>0</b>	<b>0</b>	<b>01100</b>	<b>0</b>	<b>0</b>	<b>0</b>	<b>0</b>	<b>0</b>	<b>0</b>	<b>1</b>	<b>0</b>	<b>0</b>													
<b>Bore</b>		<b>Lubrication</b>		<b>Stroke</b>		<b>Cushions / Stops</b>		<b>Dovetail cover</b>		<b>Version</b>		<b>Piston style</b>		<b>Seals</b>		<b>Fasteners</b>		<b>Porting configurations</b>		<b>End Cap Port Position <sup>Δ</sup></b>		<b>Additional carriages</b>		<b>Guides / Brakes</b>		<b>Mounting</b>		<b>Switches <sup>◇</sup></b>	
16 25 32		0 Standard 1 Slow speed 4 Food 5 Clean room S Special		xxxxxx		0 Standard 0 Standard		0 Standard X Without cover rail S Special		0 Standard		0 Standard		0 Buna-N 1 Fluorocarbon		0 Standard 1 Stainless steel 3 Xylan coated & stainless steel fasteners S Special		7 Clean Room		0 L+r 0° (pos #2)		0 None		0 None		0 None 1 A1 (16,25,32) 2 A2 (16,25,32) 3 A3 (25,32) 4 B1 (25,32) 6 B3 (16) 7 B4 (25,32) 8 B5 (32)		0 None 1 NO Reed, P8S-GRFDX2 2 NC Reed, P8S-GEFRX1 3 PNP P8S-GPCHX+4041 4 NPN KP8S-GNCHX+4041	

Note: Comes in pairs

<sup>Δ</sup> Note: End cap port position  
L = Left end cap, R = right end cap

<sup>◇</sup> Note: 2 switches will be supplied. For different quantity, please order as a separate line item.

**Sensors**  
See section L for sensors.



**G**

Rodless Pneumatic Cylinders

OSP-P Series

P1X Series

P1Z Series

GDL Series

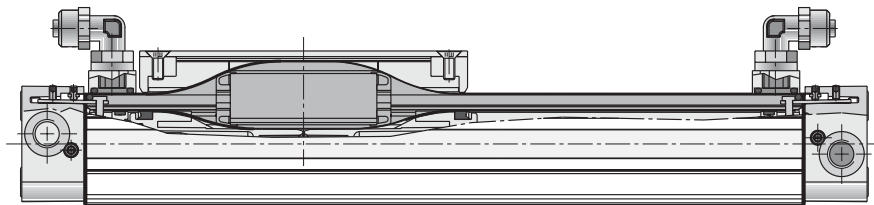
**Certification**

Based on the PARKER-ORIGA rodless cylinder, proven in world wide markets, PARKER-ORIGA now offers the only rodless cylinder on the market with a certification from IPA Institute for the clean room specification according to DIN EN ISO 14644-1.



**Function**

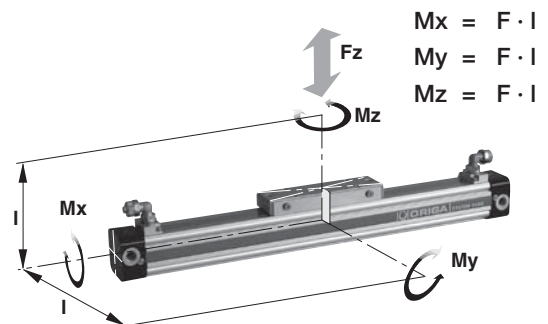
The clean room cylinders of the ORIGA SYSTEM PLUS (OSP-P) combines the efficiency of the PARKER-ORIGA slot seal system with vacuum protection against progressive wear and contamination from the sliding components. A partial vacuum drawn between inner and outer sealing bands prevents emission into the clean room. To achieve the necessary vacuum a suction flow of ca. 4 m³/h is required.



**Loads, Forces and Moments**

Cylinder Series (mm Ø)	Effective Force at 6 bar (N)	Max. Moment			Max. Load Fz (N)	Cushion length (mm)
		Mx (Nm)	My (Nm)	Mz (Nm)		
OSP-P16	78	0.45	4	0.5	120	11
OSP-P25	250	1.5	15	3.0	300	17
OSP-P32	420	3.0	30	5.0	450	20

Load and moment data are based on speeds  $v \leq 0.2$  m/s. The adjacent table shows the maximum values for light, shock-free operation which must not be exceeded even in dynamic operation.

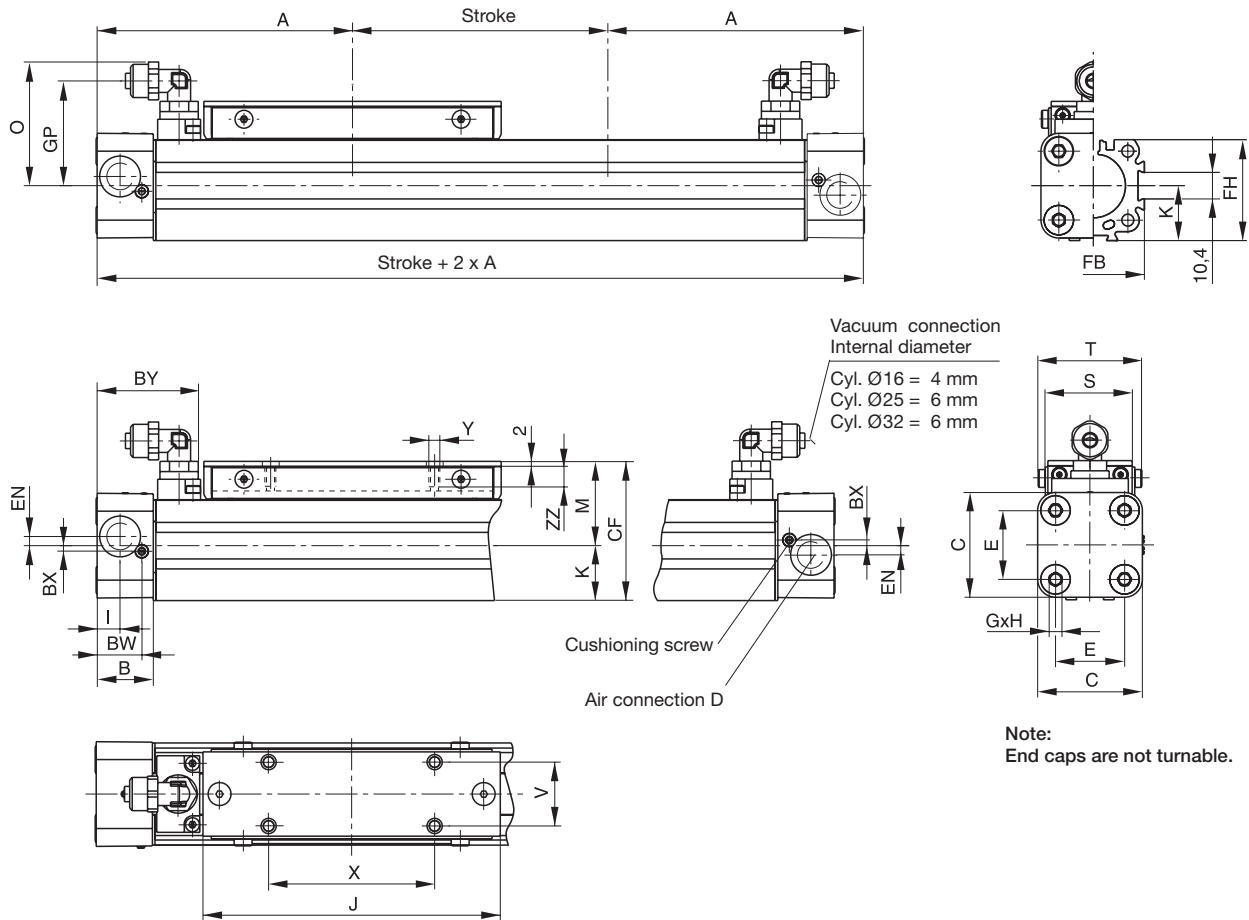


**G**  
 Rodless Pneumatic Cylinders  
 OSP-P Series  
 P1X Series  
 P1Z Series  
 GDL Series



For inventory, lead times, and kit lookup, visit [www.pdnplu.com](http://www.pdnplu.com)

**Clean Room Cylinders  $\varnothing$  16-32 mm**



**Dimension (mm)**

Series	A	B	C	D	E	G	H	I	J	K	M	O	S
OSP-P16	65	14	30	M5	18	M3	9	5.5	69	15	25	31	24
OSP-P25	100	22	41	G1/8	27	M5	15	9	117	21.5	33	48.5	35
OSP-P32	125	25.5	52	G1/4	36	M6	15	11.5	152	28.5	40	53.6	38

Series	T	V	X	Y	BW	BX	BY	CF	EN	FB	FH	GP	ZZ
OSP-P16	29.6	16.5	36	M4	10.8	1.8	28.5	40	3	30	27.2	25.7	7
OSP-P25	40.6	25	65	M5	17.5	2.2	40.5	54.5	3.6	40	39.5	41	8
OSP-P32	45	27	90	M6	20.5	2.5	47.1	68.5	5.5	52	51.7	46.2	10



For inventory, lead time, and kit lookup, visit [www.pdnplu.com](http://www.pdnplu.com)

G39

**Parker Hannifin Corporation**  
 Pneumatic Division  
 Richland, Michigan  
[www.parker.com/pneumatics](http://www.parker.com/pneumatics)



**Rodless Pneumatic Cylinders**

**OSP-P Series**

**P1X Series**

**P1Z Series**

**GDL Series**

**Features**

**Synchronized Bi-Parting movements Type OSP-P40-SL-BP for Rodless Cylinder ø 40mm**

**Standard Features:**

- Accurate bi-parting movement through toothed belt synchronization
- Optimum slow speed performance
- Increased action force
- Anodized aluminum guide rail with prism-form slideway arrangement
- Adjustable polymer slide units
- Combined sealing system with polymer and felt elements to remove dirt and lubricate the slideway
- Integrated grease nipples for guide lubrication

**Applications:**

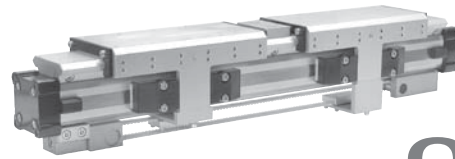
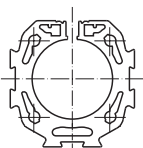
- Opening and closing operations
- Gripping of workpieces – outside
- Gripping of hollow workpieces – inside
- Gripping underneath larger objects
- Clamping force adjustable via pressure regulator

**Specifications**

- Type Rodless cylinder for synchronized bi-parting movements
- Series OSP-P
- System Double-acting, with end cushioning, for contactless position sensing
- Guide Slideline SL40
- Synchronization Toothed belt
- Mounting See drawing
- Weight (mass) See table
- Lubrication Special slow speed grease (additional oil mist lubrication not required)
- Cushioning middle position Elastic buffer
- Maximum speed 0.2 m/s  $V_{max}$
- Maximum stroke of each stroke 500 mm
- Maximum mass per guide carrier
  - lateral moment 25 Nm  $M_{x_{max}}$
  - axial moment 46 Nm  $M_{y_{max}}$
  - rotating moment 46 Nm  $M_{z_{max}}$
- Option: special slow speed grease

**Size**

P40



**Operating information**

Operating pressure:	116 PSIG (8 bar)
Temperature range:	14°F to 140°F (-10°C to 60°C)
Filtration requirements:	Filtered, nonlubricated compressed air

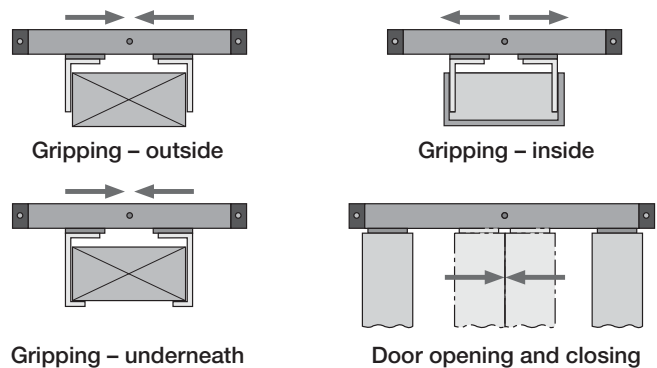
**Material specifications**

Belt wheel	Aluminum
Toothed belt	Steel-corded polyurethane

**Weight (mass) kg**

Cylinder series (Basic cylinder)	Weight (Mass) kg	
	at 0mm stroke	per 100mm stroke
OSP-P40-SL-BP	10.334	2.134

**Applications**



**G**  
 Rodless Pneumatic Cylinders  
 OSP-P Series  
 P1X Series  
 P1Z Series  
 GDL Series



For inventory, lead times, and kit lookup, visit [www.pdnplu.com](http://www.pdnplu.com)

G40

**Parker Hannifin Corporation**  
 Pneumatic Division  
 Richland, Michigan  
[www.parker.com/pneumatics](http://www.parker.com/pneumatics)

**Ordering information for OSP-P rodless basic pneumatic series**

1-4	5-6	7	8	9	10	11	12-16	17	18	19	20	21	22	23	24	25
<b>OSP</b>	<b>P</b>	<b>40</b>	<b>0</b>	<b>1</b>	<b>0</b>	<b>0</b>	<b>01100</b>	<b>0</b>	<b>0</b>	<b>0</b>	<b>0</b>	<b>0</b>	<b>0</b>	<b>1</b>	<b>0</b>	<b>0</b>

<b>Bore</b> 40	<b>Lubrication</b> 0 Standard	<b>Stroke†</b> x x x x x
<b>Piston style</b> N Bi-Parting	<b>Seals</b> 0 Standard	
<b>Porting configurations</b>	<b>Fasteners</b>	
0 Standard	0 Standard	
1 End face (position #5)	1 Stainless steel	
2 Single end ports	3 Xylan coated & stainless steel fasteners	
3 Left stand (pos #2), Right end face (pos #5)	S Special	
4 Right stand (pos #2), Left end face (pos #5)		
6 Single end porting, end face		
S Special		

<b>Cushions / Stops</b> 0 Standard	<b>Piston mounting</b> 0 None	<b>Additional carriages</b> 0 None
<b>Dovetail cover</b>	<b>Guides / Brakes</b>	<b>Mounting</b>
0 Standard	0 None	0 None
X Without cover rail		9 C1
S Special		A C2
		B C3
		C C4

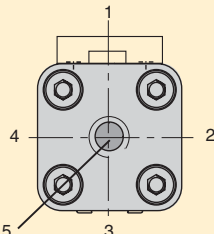
<b>Version</b> 0 Standard	<b>Switches ◊</b>	<b>End Cap Position Δ</b>
	0 None	0 l+r 0° (pos #2)
	1 NO Reed, P8S-GRFDX2	1 l+r 90° (pos #3)
	2 NC Reed, P8S-GEFRX1	2 l+r 180° (pos #4)
	3 PNP P8S-GPCHX+4041	3 l+r 270° same face as outerband (pos #2,1)
	4 NPN P8S-GNCHX+4041	4 l 90° underneath; r 0° = in front (pos #3,2)
		5 l 180° at the back; r 0° = in front (pos #4,2)
		6 l 270° same face as outerband; r 0° = in front (pos #1,2)
		7 l 0° in front; r 90° = underneath (pos #2,3)
		8 l 180° at the back; r 90° = underneath (pos #4,3)
		9 l 270° same face as outerband; r 90° = underneath (pos #1,3)
		A l 0° in front; r 180° = at the back (pos #2,4)
		B l 90° underneath; r 180° = at the back (pos #3,4)
		C l 270° same face as outerband; r 180° = at the back (pos #1,4)
		D l 0° in front; r 270° = same face as outerband (pos #2,1)
		E l 90° underneath; r 270° = same face as outerband (pos #3,1)
		F l 180° at the back; r 270° = same face as outerband (pos #4,1)
		S Special

◊ Note: 2 switches will be supplied. For different quantity, please order as a separate line item.

Δ Note: End cap port position  
 L = Left end cap, R = right end cap




**Note: Position #2 is the standard location.**

† Reference Cylinder Stroke and Dead Length A, pages G16-G17 for stroke consideration because of the use of two pistons.

**Sensors**  
See section L for sensors.



**Function:**

The OSP-P40-SL-BP bidirectional linear drive is based on the OSP-P40 rodless pneumatic cylinder and adapted SLIDELINE SL40 polymer plain-bearing guides.

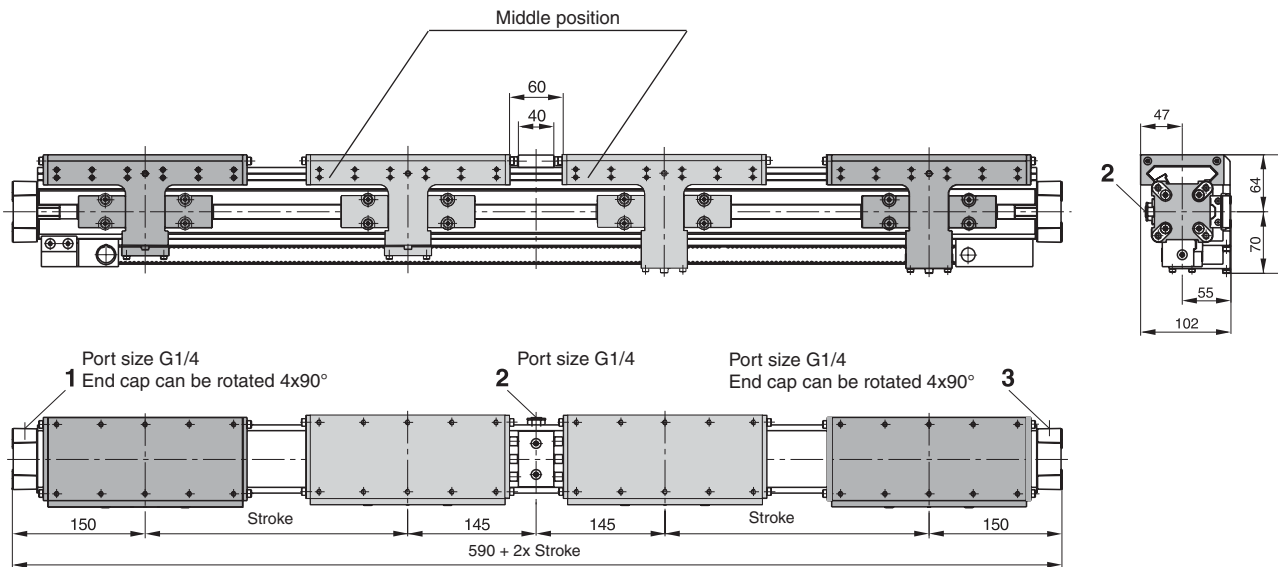
Two pistons in the cylinder bore are connected via yokes and carriers to the SLIDELINE guide carriers, which handle the forces and moments generated.

The bi-parting movements of the guide carriers are accurately synchronized by a recirculating toothed belt.

The two pistons are driven from the middle to the end positions via a common G1/4 air connection in the middle of the cylinder, and are driven from the end positions to the middle via an air connection in each end cap.

End position cushioning is provided by adjustable air cushioning in the end caps, and middle position cushioning by rubber buffers.

**Dimensions (mm)**



**Air connections:**

To drive the guide carriers to the middle position: pressurize ports 1 and 3.

To drive the guide carriers to the end positions: pressurize port 2.

For more dimensions see pages G18 and G19.

<b>G</b>	Rodless Pneumatic Cylinders
	OSP-P Series
P1X Series	
P1Z Series	
GDL Series	



For inventory, lead times, and kit lookup, visit [www.pdnplu.com](http://www.pdnplu.com)



Linear Guides for OSP-P Series



Adaptive modular system

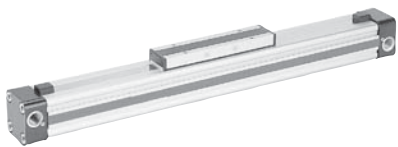
The Origa system plus – OSP – provides a comprehensive range of linear guides for the pneumatic OSP-P.

Advantages:

- Takes high loads and forces
- High precision
- Smooth operation
- Can be retrofitted
- Can be installed in any position

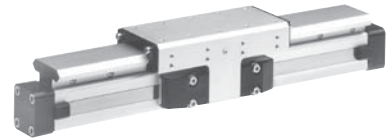
Series OSP-P - Standard

- Piston diameters 10 to 80mm



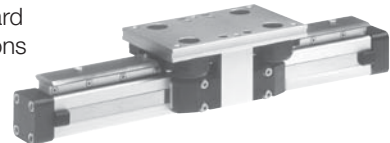
SLIDELINE

- The cost-effective plain bearing guide for medium loads.
- Active/ Passive Brake optional.
- Piston diameters 16 to 80mm



POWERSLIDE

- The roller guide for heavy loads and hard application conditions
- Piston diameters 16 to 50mm



PROLINE

- The compact aluminum roller guide for high loads and velocities.
- Active / Passive Brake optional.
- Piston diameters 16 to 50mm



STARLINE

- Recirculating ball bearing guide for very high loads and precision
- Piston diameters 16 to 50mm



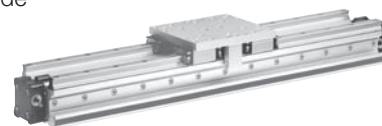
KF GUIDE

- Recirculating ball bearing guide for highest loads and precision.
- Correspond to FESTO dimensions (Type DGPL-KF)
- Piston diameters 16 to 50mm



HD HEAVY DUTY GUIDE

- The ball bushing guide for the heavy loads and greatest accuracy.
- Piston diameters 25 to 50mm



Rodless Pneumatic Cylinders

OSP-P Series

P1X Series

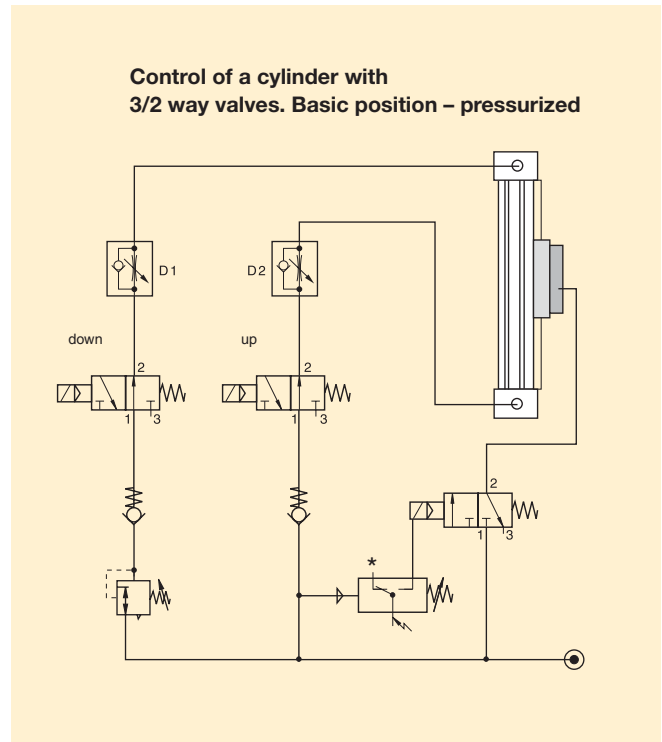
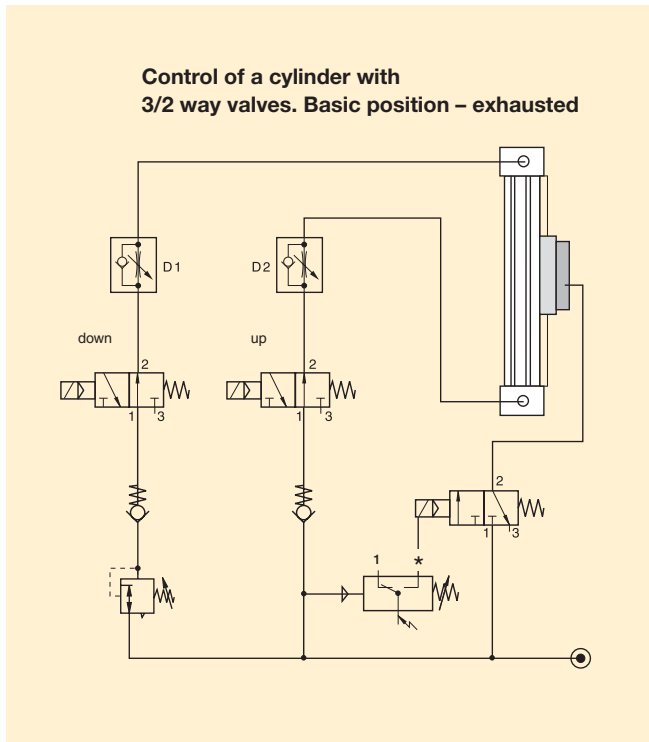
P1Z Series

GDL Series



For inventory, lead time, and kit lookup, visit [www.pdnplu.com](http://www.pdnplu.com)

**Application Example - Vertical Application**



<b>G</b> Rodless Pneumatic Cylinders	Control Examples
	OSP-P Series
	P1X Series
	P1Z Series
	GDL Series

**Control Examples**

Under normal operating circumstances the pressure switch is closed and the air flows through the 3/2 way solenoid valves from port 1 to 2, thus lifting the brake from the rail (operating condition).

The brake is pressurized by means of a 3/2 way valve in combination with a pressure switch. When there is a pressure loss, the brake is actuated by the pressure switch.

When the air pressure is restored to both cylinder chambers, the brake is lifted and the linear drive can be moved again.

The speed regulating valves D1 and D2 control the speed of the linear drive, and have no influence on the brake. The two non-return valves give the system a higher stability.

The pressure regulating valve is used to compensate for the downward force in this vertical application.

**Please note:**



**Before the brake is lifted, make sure that both air chambers of the linear drive are pressurized.**

**Small diameter tubing, fittings and valves with a nominal diameter, and tubing that is too long all change the reaction time of the brake!**

**\* Tip:**

The pressure switch actuates the brake when the pressure drops below the set value.

For accessories, such as tubing and fittings, please refer to our separate catalog.

**Required Components**

- Three, Three-Way Valves
- Port size  
M5, G1/8, G1/4, G1/2
- Pressure Regulator  
G1/8 - G3/8
- Pneumatic Accessories
- P/E-Switch
- Check Valves  
G1/8 - G3/8
- Flow Control Valves  
M5 - G1/4

Contact factory for literature on the above valves/accessories



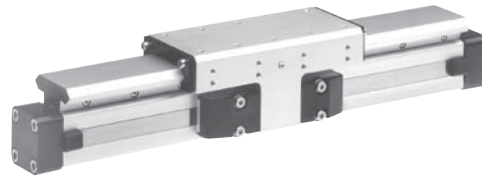
For inventory, lead times, and kit lookup, visit [www.pdnplu.com](http://www.pdnplu.com)

**Features**

**SLIDELINE, Plain Bearing Guide SL ø 16 to 80mm bore**

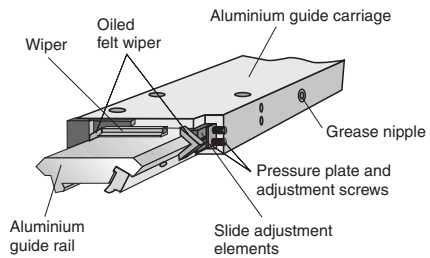
**For Linear-drive**

- Series OSP-P



**Features**

- Maximum speed < 1 m/s
- Adjustable plastic slide elements – optional with integral brake
- Composite sealing system with plastic and felt wiper elements to remove dirt and lubricate the slideways
- Corrosion resistant version available on request
- Any length of stroke up to 5500mm (longer strokes on request)

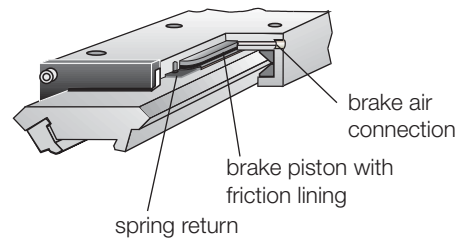


**Integrated Brake (optional) for series OSP-P25 to OSP-P50:**

- Actuated by pressure
- Released by exhausting and spring return

For further technical data see also linear drives OSP-P, see page G14.

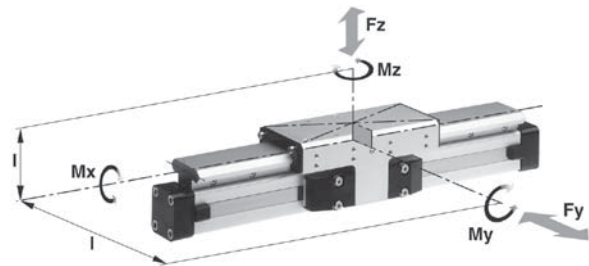
**Option – Integrated Brake**



**Loads, Forces and Moments**

The table shows the maximum permissible values for smooth operation, which should not be exceeded even under dynamic conditions.

The load and moment figures apply to speeds  $v < 0.2$  m/s.



Series	For linear drive	Max. moments (Nm)			Max. loads (N) Fy, Fz	Maximum braking force a 6 bar (N)†	Mass of linear drive with guide (kg)		
		Mx	My	Mz			With 0mm stroke	Increase per 100mm stroke	Mass * of guide carriage (kg)
SL16	OSP-P16	6	11	11	325	–	0.57	0.22	0.23
SL25	OSP-P25	14	34	34	675	325	1.55	0.39	0.61
SL32	OSP-P32	29	60	60	925	545	2.98	0.65	0.95
SL40	OSP-P40	50	110	110	1500	835	4.05	0.78	1.22
SL50	OSP-P50	77	180	180	2000	1200	6.72	0.97	2.06
SL63	OSP-P63	120	260	260	2500	–	11.66	1.47	3.32
SL80	OSP-P80	120	260	260	2500	–	15.71	1.81	3.32

\* Add the mass of the guide carriage to the mass to be cushioned.

† Only with integrated brake: Braking force on dry oil-free surface values are decreased for lubricated slideways.



For inventory, lead time, and kit lookup, visit [www.pdnplu.com](http://www.pdnplu.com)

Ordering information for OSP-P rodless SLIDELINE pneumatic series

1-4	5-6	7	8	9	10	11	12-16	17	18	19	20	21	22	23	24	25
<b>OSP</b>	<b>P</b>	<b>25</b>	<b>0</b>	<b>1</b>	<b>0</b>	<b>0</b>	<b>01100</b>	<b>0</b>	<b>0</b>	<b>0</b>	<b>0</b>	<b>0</b>	<b>0</b>	<b>1</b>	<b>0</b>	<b>0</b>

<b>Bore</b>	<b>Lubrication</b>	<b>Stroke</b>	<b>Cushions / Stops</b>	<b>Dovetail cover</b>	<b>Version</b>
16 25 32 40 50 63 80	0 Standard 1 Slow speed 4 Food 5 Clean room S Special	xxxxx	0 Standard S Special	0 Standard X Without cover rail S Special	0 Standard

<b>Piston style</b>	<b>Seals</b>	<b>Fasteners</b>	<b>Piston mounting</b>	<b>Guides / Brakes</b>	<b>Mounting</b>
0 Standard 1 Tandem	0 Standard 1 Fluorocarbon	0 Standard 1 Stainless steel 3 Xylan coated & stainless steel fasteners S Special	0 None	2 SL Slideline A SL Slideline with Active brake 4 SL Slideline with Multibrake (without sensors)	0 None 1 A1 (16,25,32) 2 A2 (16,25,32) 3 A3 (25,32) 4 B1 (25,32) 6 B3 (16) 7 B4 (25,32) 8 B5 (32) 9 C1 (40,50,63,80) A C2 (40,50) B C3 (40,50,63,80) C C4 (40,50)

<b>Porting configurations</b>	<b>End Cap Port Position <math>\Delta</math></b>
0 Standard (position #2) 1 End face (position #5) 2 Single end porting 3 Left stand (pos #2), Right end face (pos #5) 4 Right stand (pos #2), Left end face (pos #5) 6 Single end porting, end face A 3/2 way valve VOE, 24V = (25,32,40,50) B 3/2 way valve VOE, 220V~/110V = (25,32,40,50) C 3/2 way valve VOE, 48V = (25,32,40,50) E 3/2 way valve VOE, 110V = (25,32,40,50) S Special	0 I+r 0° = in front (pos #2) 1 I+r 90° = underneath (pos #3) 2 I+r 180° = at the back (pos #4) 3 I+r 270° = same face as outerband (pos #2,1) 4 I 90° = underneath; r 0° = in front (pos #3,2) 5 I 180° = at the back; r 0° = in front (pos #4,2) 6 I 270° = same face as outerband; r 0° = in front (pos #1,2) 7 I 0° = in front; r 90° = underneath (pos #2,3) 8 I 180° = at the back; r 90° = underneath (pos #4,3) 9 I 270° = same face as outerband; r 90° = underneath (pos #1,3) A I 0° = in front; r 180° = at the back (pos #2,4) B I 90° = underneath; r 180° = at the back (pos #3,4) C I 270° = same face as outerband; r 180° = at the back (pos #1,4) D I 0° = in front; r 270° = same face as outerband (pos #2,1) E I 90° = underneath; r 270° = same face as outerband (pos #3,1) F I 180° = at the back; r 270° = same face as outerband (pos #4,1) S Special

Note: Single end porting on 16mm bore, then end caps cannot be rotated.

**Cylinder with guide end cap positioning**

<b>Additional carriages**</b>	<b>Switches <math>\diamond</math></b>
0 None 2 Guide Carriage Slideline SL 3 Guide Carriage SL-AB 4 Guide Carriage SL-MB M Guide Carriage SL-MB without Brake Function	0 None 1 NO Reed, P8S-GRFDX2 2 NC Reed, P8S-GEFRX1 3 PNP P8S-GPCHX+4041 4 NPN P8S-GNCHX+4041 X 21240 SFI 0,1mm Y 21241 SFI 1mm Z 4650 SFA S Special

$\diamond$  Note: 2 switches will be supplied. For different quantity, please order as a separate line item.

<b>Sensors</b> See section L for sensors.	
--	--

$\Delta$  Note: End cap port position  
L = Left end cap, R = right end cap

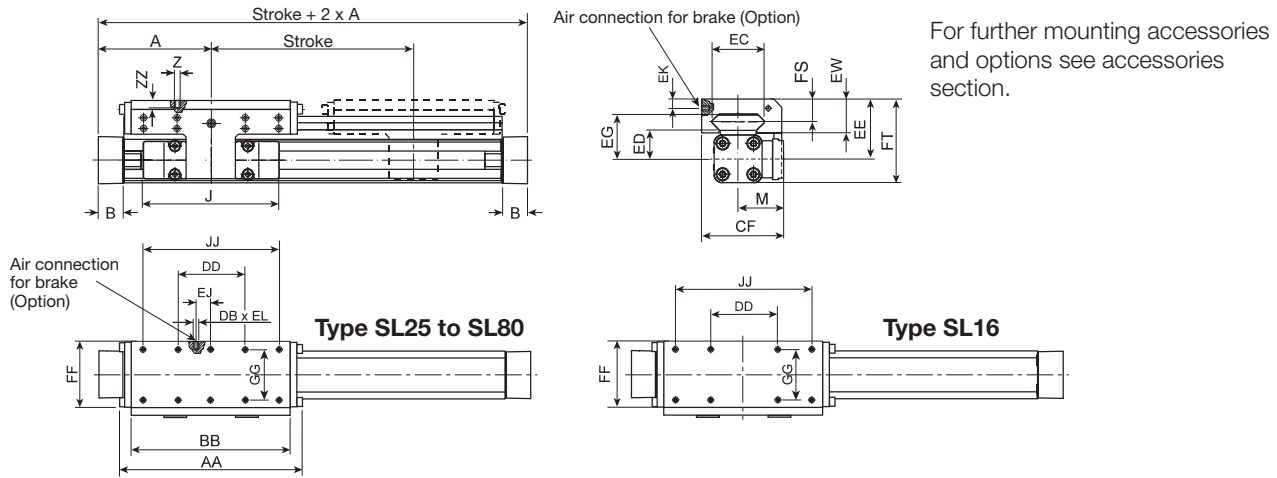
**G**  
 Rodless Pneumatic Cylinders  
 OSP-P Series  
 P1X Series  
 P1Z Series  
 GDL Series



For inventory, lead times, and kit lookup, visit [www.pdnplu.com](http://www.pdnplu.com)

G46

**SLIDELINE  $\varnothing$  16 to 80mm**



**Dimensions (mm)**

Series	A	B	J	M	Z	AA	BB	DB	DD	CF	EC	ED	EE	EG	EJ	EK	EL	EW	FF	FT	FS	GG	JJ	ZZ
SL 16	65	14	69	31	M4	106	88	-	30	55	36	8	40	30	-	-	-	22	48	55	14	36	70	8
SL 25	100	22	117	40.5	M6	162	142	M5	60	72.5	47	12	53	39	22	6	6	30	64	73.5	20	50	120	12
SL 32	125	25.5	152	49	M6	205	185	M5	80	91	67	14	62	48	32	6	6	33	84	88	21	64	160	12
SL 40	150	28	152	55	M6	240	220	M5	100	102	77	14	64	50	58	6	6	34	94	98.5	21.5	78	200	12
SL 50	175	33	200	62	M6	284	264	M5	120	117	94	14	75	56	81	6	6	39	110	118.5	26	90	240	16
SL 63	215	38	256	79	M8	312	292	-	130	152	116	18	86	66	-	-	-	46	152	139	29	120	260	14
SL 80	260	47	348	96	M8	312	292	-	130	169	116	18	99	79	-	-	-	46	152	165	29	120	260	14

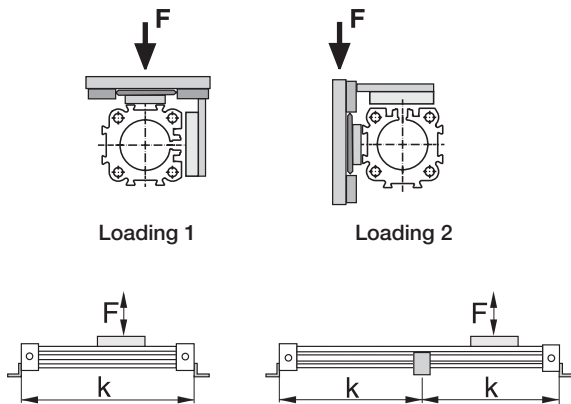
**Mid-Section Support**

(for versions see page G83)

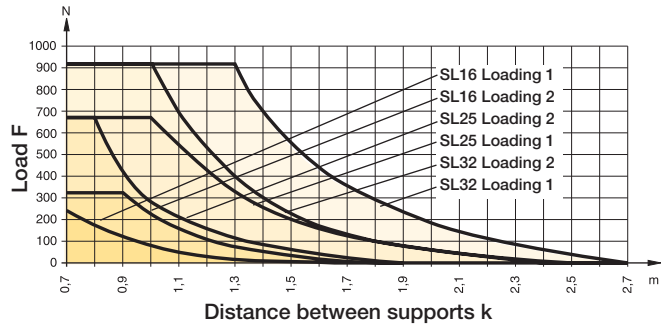
Mid-section supports are required from a certain stroke length to prevent excessive deflection and vibration of the linear drive. The diagrams show the maximum permissible unsupported length in relation to loading. A distinction must be drawn between loading 1 and loading 2.

Deflection of 0.5 mm max. between supports is permissible.

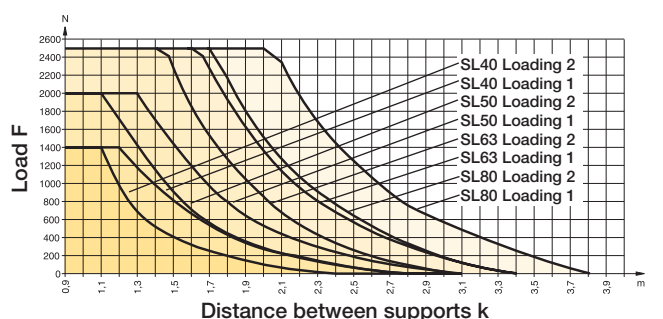
**Note:** For speeds  $v > 0.5$  m/s the distance between supports should not exceed 1 m.



**SLIDELINE 16 to 32mm bore**



**SLIDELINE 40 to 80mm bore**



For inventory, lead time, and kit lookup, visit [www.pdnplu.com](http://www.pdnplu.com)

**Multi-Brake Passive Brakes MB-SL ø 25 to 80mm bore**

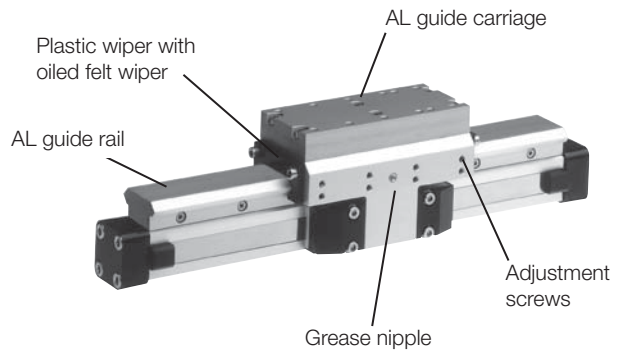
**Series MB-SL 25 to 80 for Linear-drive**



- Series OSP-P

**Features**

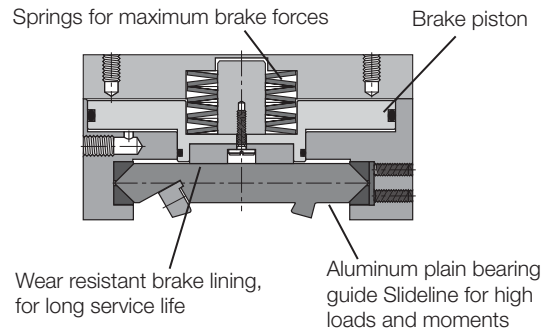
- Brake operated by spring actuation
- Brake release by pressurization
- Anodized aluminum rail, with prism shaped slide elements
- Adjustable plastic slide elements
- Composite sealing system with plastic and felt wiper elements to remove dirt and lubricate the slideway
- Replenishable guide lubrication by integrated grease nipples
- Blocking function in case of pressure loss
- Intermediate stops possible



**Function**

The Multi-Brake is a passive device. When the air pressure is removed the brake is actuated and movement of the cylinder is blocked. The brake is released by pressurization.

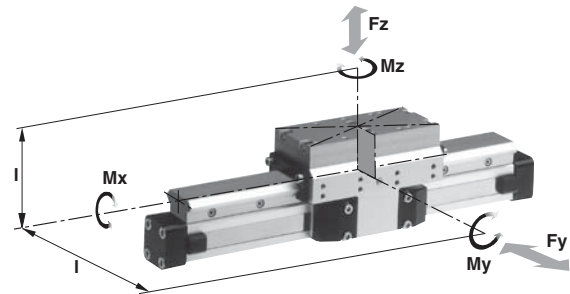
The high friction, wear resistant brake linings allow the Multi-Brake to be used as a dynamic brake to stop cylinder movement in the shortest possible time. The powerful springs also allow the Multi-Brake to be used effectively in positioning applications.



**Loads, Forces and Moments**

The table shows the maximum values for light, shock-free operation, which must not be exceeded even in dynamic operation.

Load and moment data are based on speeds  $v < 0.2$  m/s.



Series	For linear drive	Max. moments (Nm)			Max. loads (N)		Maximum braking force a 6 bar (N) †	Mass of linear drive with guide (kg)		
		Mx	My	Mz	Fy, Fz	With 0mm stroke		Increase per 100mm stroke	Mass * guide carriage (kg)	
MB-SL25	OSP-P25	14	34	34	675	470	2.04	0.39	1.10	
MB-SL32	OSP-P32	29	60	60	925	790	3.82	0.65	1.79	
MB-SL40	OSP-P40	50	110	110	1500	1200	5.16	0.78	2.34	
MB-SL50	OSP-P50	77	180	180	2000	1870	8.29	0.97	3.63	
MB-SL63	OSP-P63	120	260	260	2500	2900	13.31	1.47	4.97	
MB-SL80	OSP-P80	120	260	260	2500	2900	17.36	1.81	4.97	

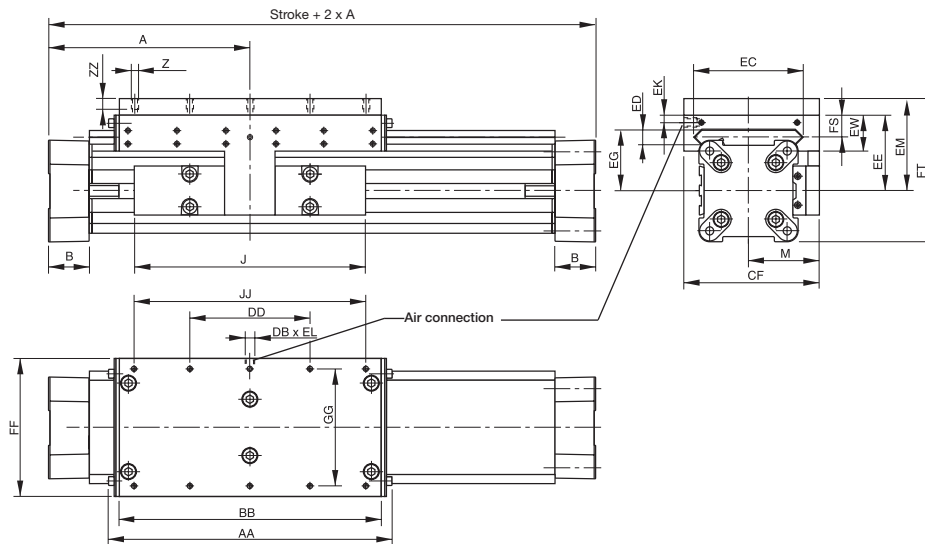
\* Add the mass of the guide carriage to the mass to be cushioned.  
 † Braking surface dry – oil on the braking surface will reduce the raking force.

**G**  
 Rodless Pneumatic Cylinders  
 OSP-P Series  
 P1X Series  
 P1Z Series  
 GDL Series



For inventory, lead times, and kit lookup, visit [www.pdnplu.com](http://www.pdnplu.com)

**OSP-P with Passive Brake MB-SL**



**Dimension (mm)**

Series	A	B	J	M	Z	AA	BB	DB	DD	CF	EC	ED	EE	EG	EK	EL	EM	EW	FF	FT	FS	GG	JJ	ZZ
MB-SL25	100	22	117	40,5	M6	162	142	M5	60	72.5	47	12	53	39	9	5	73	30	64	93.5	20	50	120	12
MB-SL32	125	25.5	152	49	M6	205	185	G1/8	80	91	67	14	62	48	7	10	82	33	84	108	21	64	160	12
MB-SL40	150	28	152	55	M6	240	220	G1/8	100	102	77	14	64	50	6.5	10	84	34	94	118.5	21.5	78	200	12
MB-SL50	175	33	200	62	M6	284	264	G1/8	120	117	94	14	75	56	10	12	95	39	110	138.5	26	90	240	12
MB-SL63	215	38	256	79	M8	312	292	G1/8	130	152	116	18	86	66	11	12	106	46	152	159	29	120	260	13
MB-SL80	260	47	348	96	M8	312	292	G1/8	130	169	116	18	99	79	11	12	119	46	152	185	29	120	260	13

**Mid-Section Support**

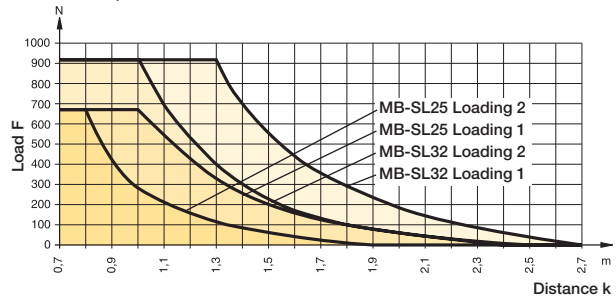
(for versions see page G83)

Mid-Section supports are required from a certain stroke length to prevent excessive deflection and vibration of the linear drive.

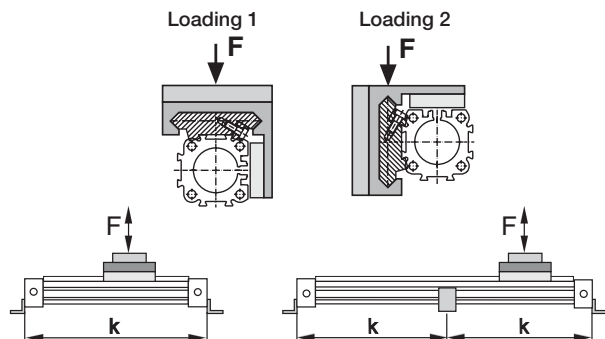
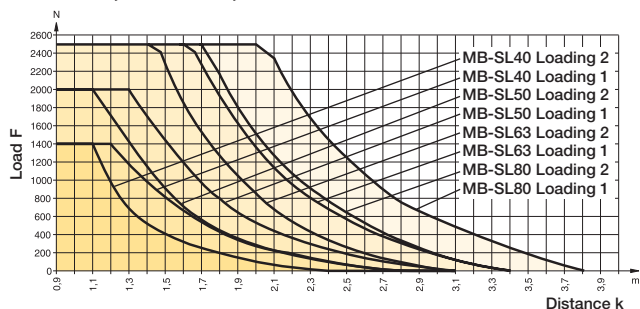
The diagrams show the maximum permissible unsupported length in relation to loading. A distinction must be drawn between loading 1 and loading 2. Deflection of 0.5 mm max. between supports is permissible.

**Note:** For speeds  $v > 0.5$  m/s the distance between supports should not exceed 1 m.

**Permissible Unsupported Length  
 MB-SL25, MB-SL32**



**Permissible Unsupported Length  
 MB-SL40, MB-SL50, MB-SL63 and MB-SL80**



For inventory, lead time, and kit lookup, visit [www.pdnplu.com](http://www.pdnplu.com)

**Features**

**Multi-Brake Passive Brakes PS ø 16 to 50mm bore**

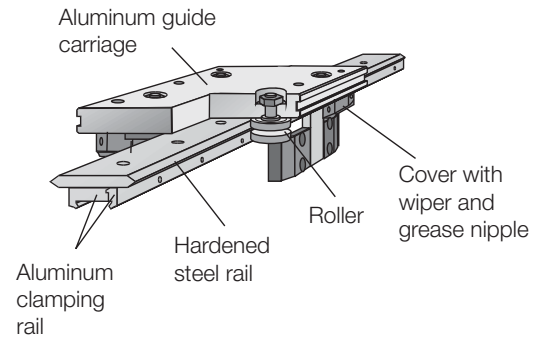
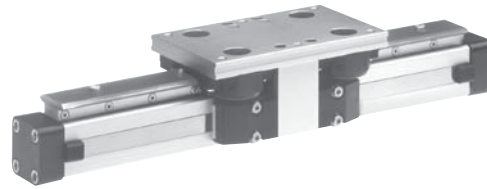
**Series PS 16 to 50 for Linear-drive**

- Series OSP-P



**Features**

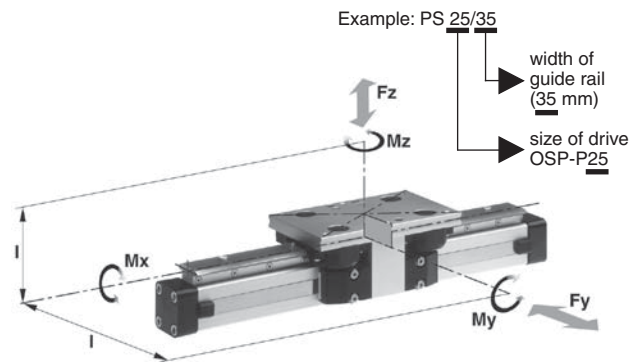
- Anodized aluminum guide carriage with vee rollers having 2 rows of ball bearings
- Hardened steel guide rail
- Several guide sizes can be used on the same drive
- Corrosion resistance version available on request
- Max. Speed  $v = 3 \text{ m/s}$
- Tough roller cover with wiper and grease nipple
- Any length of stroke up to 3500mm



**Loads, Forces and Moments**

The table shows the maximum permissible values for smooth operation, which should not be exceeded even under dynamic conditions.

For further information and technical data see linear drives OSP-P.



Series	For linear drive	Max. moments (Nm)			Max. load (N)	Mass of linear drive with guide (kg)		
		Mx	My	Mz		Fy, Fz	With 0mm stroke	Increase per 100mm stroke
PS 16/25	OSP-P16	14	45	45	1400	0.93	0.24	0.7
PS 25/25	OSP-P25	14	63	63	1400	1.5	0.4	0.7
PS 25/35	OSP-P25	20	70	70	1400	1.7	0.4	0.8
PS 25/44	OSP-P25	65	175	175	3000	2.6	0.5	1.5
PS 32/35	OSP-P32	20	70	70	1400	2.6	0.6	0.8
PS 32/44	OSP-P32	65	175	175	3000	3.4	0.7	1.5
PS 40/44	OSP-P40	65	175	175	3000	4.6	1.1	1.5
PS 40/60	OSP-P40	90	250	250	3000	6	1.3	2.2
PS 50/60	OSP-P50	90	250	250	3000	7.6	1.4	2.3
PS 50/76	OSP-P50	140	350	350	4000	11.5	1.8	4.9

\* Add the mass of the guide carriage to the mass to be cushioned.

**G**  
 Rodless Pneumatic Cylinders  
 OSP-P Series  
 P1X Series  
 P1Z Series  
 GDL Series



For inventory, lead times, and kit lookup, visit [www.pdnplu.com](http://www.pdnplu.com)

G50

**Parker Hannifin Corporation**  
 Pneumatic Division  
 Richland, Michigan  
[www.parker.com/pneumatics](http://www.parker.com/pneumatics)



**Ordering information for OSP-P rodless POWERSLIDE pneumatic series**

1-4 <b>OSP</b>	5-6 <b>25</b>	7 <b>0</b>	8 <b>1</b>	9 <b>0</b>	10 <b>0</b>	11 <b>0</b>	12-16 <b>01100</b>	17 <b>0</b>	18 <b>0</b>	19 <b>0</b>	20 <b>0</b>	21 <b>0</b>	22 <b>0</b>	23 <b>1</b>	24 <b>0</b>	25 <b>0</b>
-------------------	------------------	---------------	---------------	---------------	----------------	----------------	-----------------------	----------------	----------------	----------------	----------------	----------------	----------------	----------------	----------------	----------------

**Bore**

16
25
32
40
50

**Lubrication**

0	Standard
1	Slow speed
4	Food
5	Clean room
S	Special

**Stroke**

x x x x x
-----------

**Cushions / Stops**

0	Standard
S	Special

**Piston style**

0	Standard
1	Tandem

**Seals**

0	Standard
1	Fluorocarbon

**Fasteners**

0	Standard
1	Stainless steel
3	Xylan coated & stainless steel fasteners
S	Special

**Guides / Brakes**

E	PSXX/25 Powerslide (16,25)
F	PSXX/35 Powerslide (25,32)
G	PSXX/44 Powerslide (16,25)
H	PSXX/60 Powerslide (25,32,40)
I	PSXX/76 Powerslide (50)

**Porting configurations**

0	Standard (position #2)
1	End face (position #5)
2	Single end porting
3	Left stand (pos #2), Right end face (pos #5)
4	Right stand (pos #2), Left end face (pos #5)
6	Single end porting, end face
A	3/2 way valve VOE, 24V = (25,32,40,50)
B	3/2 way valve VOE, 220V~/110V = (25,32,40,50)
C	3/2 way valve VOE, 48V = (25,32,40,50)
E	3/2 way valve VOE, 110V = (25,32,40,50)
S	Special

**End Cap Port Position  $\Delta$**

0	l+r 0° = in front (pos #2)
1	l+r 90° = underneath (pos #3)
2	l+r 180° = at the back (pos #4)
3	l+r 270° = same face as outerband (pos #2,1)
4	l 90° = underneath; r 0° = in front (pos #3,2)
5	l 180° = at the back; r 0° = in front (pos #4,2)
6	l 270° = same face as outerband; r 0° = in front (pos #1,2)
7	l 0° = in front; r 90° = underneath (pos #2,3)
8	l 180° = at the back; r 90° = underneath (pos #4,3)
9	l 270° = same face as outerband; r 90° = underneath (pos #1,3)
A	l 0° = in front; r 180° = at the back (pos #2,4)
B	l 90° = underneath; r 180° = at the back (pos #3,4)
C	l 270° = same face as outerband; r 180° = at the back (pos #1,4)
D	l 0° = in front; r 270° = same face as outerband (pos #2,1)
E	l 90° = underneath; r 270° = same face as outerband (pos #3,1)
F	l 180° = at the back; r 270° = same face as outerband (pos #4,1)
S	Special

**Additional carriages\*\***

0	None
E	Guide Carriage Powerslide PSXX/25 (16,25)
F	Guide Carriage Powerslide PSXX/35 (25,32)
G	Guide Carriage Powerslide PSXX/44 (25,32,40)
H	Guide Carriage Powerslide PSXX/50 (40,50)

**Mounting**

0	None
1	A1 (16,25,32)
2	A2 (16,25,32)
3	A3 (25,32)
4	B1 (25,32)
6	B3 (16)
7	B4 (25,32)
8	B5 (32)
9	C1 (40,50)
A	C2 (40,50)
B	C3 (40,50)
C	C4 (40,50)

Note: Comes in pairs

**Dovetail cover**

0	Standard
X	Without cover rail
S	Special

**Version**

0	Standard
---	----------

Note: Single end porting on 16mm bore, then end caps cannot be rotated.

**Cylinder with guide end cap positioning**

$\Delta$  Note: End cap port position  
 L = Left end cap, R = right end cap

**Switches  $\diamond$**

0	None
1	NO Reed, P8S-GRFDX2
2	NC Reed, P8S-GEFRX1
3	PNP P8S-GPCHX+4041
4	NPN P8S-GNCHX+4041
X	21240 SFI 0,1mm
Y	21241 SFI 1mm
Z	4650 SFA
S	Special

$\diamond$  Note: 2 switches will be supplied. For different quantity, please order as a separate line item.

**Sensors**

See section L for sensors.

**G**

**Rodless Pneumatic Cylinders**

**OSP-P Series**

**P1X Series**

**P1Z Series**

**GDL Series**

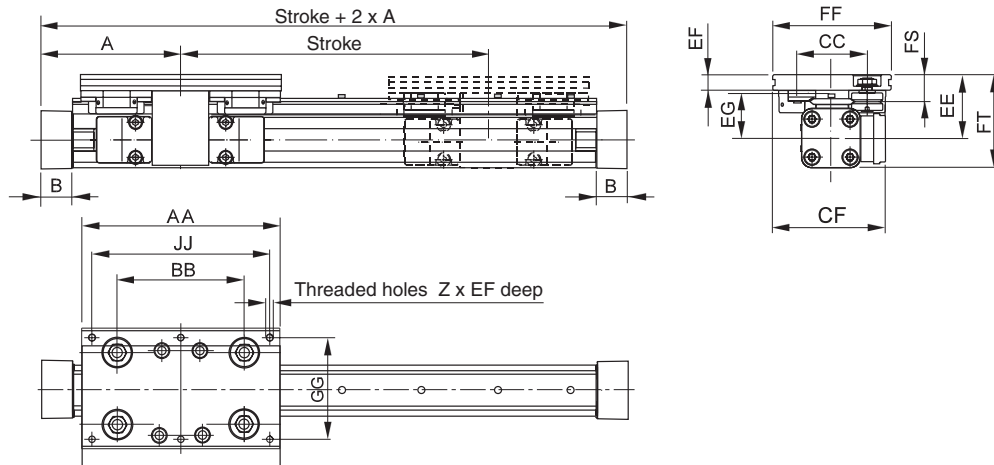


For inventory, lead time, and kit lookup, visit [www.pdnplu.com](http://www.pdnplu.com)

G51

**Parker Hannifin Corporation**  
 Pneumatic Division  
 Richland, Michigan  
[www.parker.com/pneumatics](http://www.parker.com/pneumatics)

**POWERSLIDE Dimensions**



**Dimensions (mm)**

Series	A	B	Z	AA	BB	CC	CF	EE	EF	EG	FF	FS	FT	GG	JJ
PS 16/25	65	14	4xM6	120	65	47	80	49	12	35	80	21	64	64	100
PS 25/25	100	22	6xM6	145	90	47	79.5	53	11	39	80	20	73.5	64	125
PS 25/35	100	22	6xM6	156	100	57	89.5	52.5	12.5	37.5	95	21.5	73	80	140
PS 25/44	100	22	6xM8	190	118	73	100	58	15	39	116	26	78.5	96	164
PS 32/35	125	25.5	6xM6	156	100	57	95.5	58.5	12.5	43.5	95	21.5	84.5	80	140
PS 32/44	125	25.5	6xM8	190	118	73	107	64	15	45	116	26	90	96	164
PS 40/44	150	28	6xM8	190	118	73	112.5	75	15	56	116	26	109.5	96	164
PS 40/60	150	28	6xM8	240	167	89	122.5	74	17	54	135	28.5	108.5	115	216
PS 50/60	175	33	6xM8	240	167	89	130.5	81	17	61	135	28.5	123.5	115	216
PS 50/76	175	33	6xM10	280	178	119	155.5	93	20	64	185	39	135.5	160	250

**Service Life**

Calculation of service life is achieved in two stages:

- Determination of load factor Lf from the loads to be carried
- Calculation of service life in km

**1. Calculation of load factor Lf**

$$LF = \frac{Mx}{Mx_{max}} + \frac{My}{My_{max}} + \frac{Mz}{Mz_{max}} + \frac{Fy}{Fy_{max}} + \frac{Fz}{Fz_{max}}$$

with combined loads, Lf should not exceed the value 1.

**Lubrication**

For maximum system life, lubrication of the rollers must be maintained at all times.

Only high quality Lithium based greases should be used.

Lubrication intervals are dependent on environmental conditions (temperature, running speed, grease quality etc.) therefore the installation should be regularly inspected.

**2. Service life calculation**

- For PS 16/25, PS 25/25, PS 25/35, and PS 32/35

$$\text{Service life (km)} = \frac{106}{(LF + 0,02)^3}$$

- For PS 25/44, PS 32/44, PS 40/44, PS 40/60 and PS 50/60:

$$\text{Service life (km)} = \frac{314}{(LF + 0,015)^3}$$

- For PS 50/76:

$$\text{Service life (km)} = \frac{680}{(LF + 0,015)^3}$$

**G**  
 Rodless Pneumatic Cylinders  
 OSP-P Series  
 P1X Series  
 P1Z Series  
 GDL Series



For inventory, lead times, and kit lookup, visit [www.pdnplu.com](http://www.pdnplu.com)

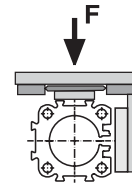
**Mid-Section Support**

(for versions see page G83)

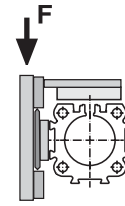
Mid-section supports are required from a certain stroke length to prevent excessive deflection and vibration of the linear drive. The diagrams show the maximum permissible unsupported length in relation to loading. A distinction must be drawn between loading 1 and loading 2.

Deflection of 0.5 mm max. between supports is permissible.

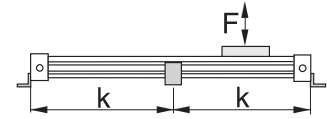
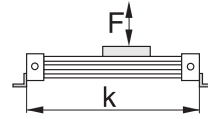
**Note:** For speeds  $v > 0.5$  m/s the distance between supports should not exceed 1 m.



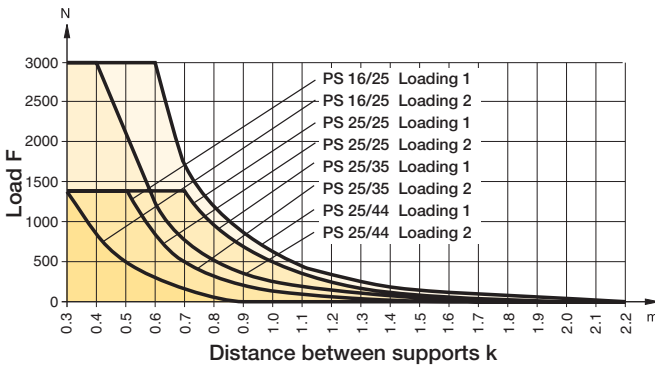
Loading 1



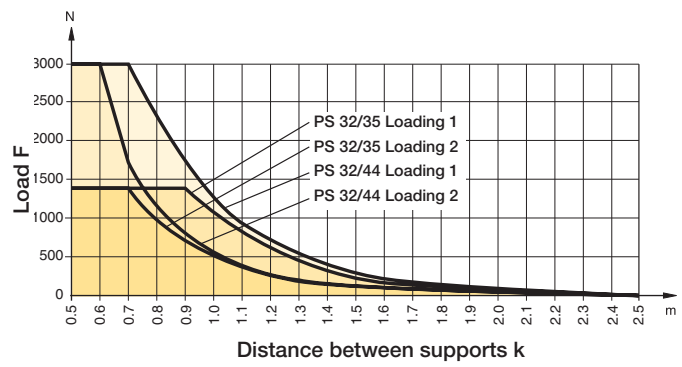
Loading 2



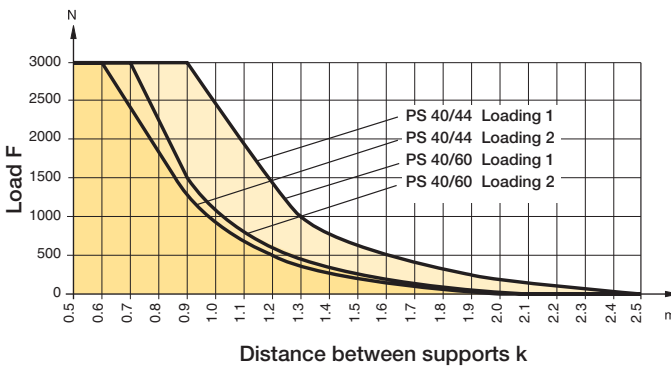
**Permissible unsupported length:  
 POWERSLIDE 16/25, 25/25, 25/35, 25/44mm bore**



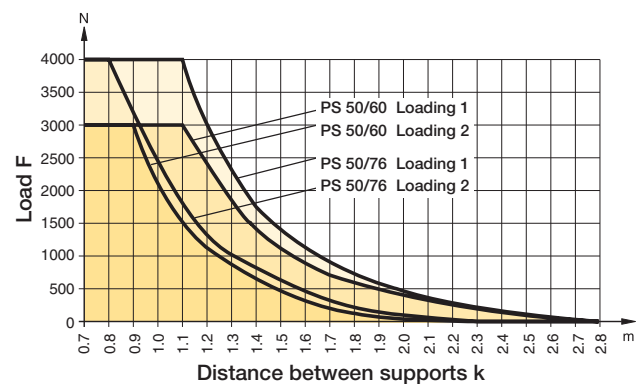
**Permissible unsupported length:  
 POWERSLIDE 2/35, 32/44mm bore**



**Permissible unsupported length:  
 POWERSLIDE 40/44, 40/60mm bore**



**Permissible unsupported length:  
 POWERSLIDE 50/60, 50/76mm bore**



Rodless Pneumatic  
 Cylinders

OSP-P  
 Series

P1X  
 Series

P1Z  
 Series

GDL  
 Series



For inventory, lead time, and kit lookup, visit [www.pdnplu.com](http://www.pdnplu.com)

G53

**Parker Hannifin Corporation**  
 Pneumatic Division  
 Richland, Michigan  
[www.parker.com/pneumatics](http://www.parker.com/pneumatics)

**Features**

**Aluminum Roller Guide PROLINE PL ø 16 to 50mm bore**

**Series PL 16 to 50 for Linear-drive**

- Series OSP-P

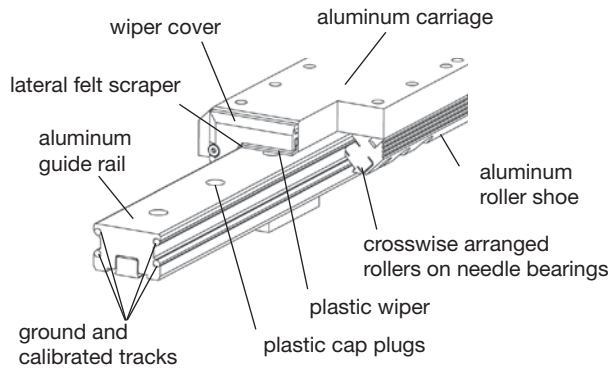


**Features**

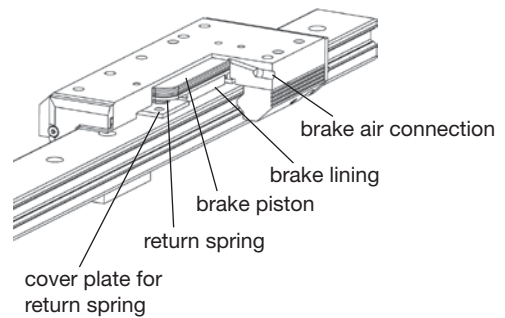
- High precision
- High velocities (10 m/s)
- Smooth operation - low noise
- Integrated wiper system
- Long life lubrication
- Compact dimensions - compatible to Slideline plain bearing guide
- Any length of stroke up to 3750mm

**Integrated Brake (optional) for Series OSP-P25 to OSP-P50:**

- Actuated by pressurization
- Release by depressurization and spring actuation



**Option – Integrated Brake**



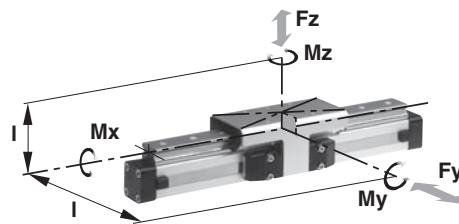
**Loads, Forces and Moments**

The table shows the maximal permissible loads. If multiple moments and forces act upon the cylinder simultaneously, the following equation applies:

$$\frac{M_x}{M_{xmax}} + \frac{M_y}{M_{ymax}} + \frac{M_z}{M_{zmax}} + \frac{F_y}{F_{ymax}} + \frac{F_z}{F_{zmax}} \leq 1$$

**The sum of the loads should not exceed >1. With a load factor of less than 1, service life is 8000 km**

The table shows the maximum permissible values for light, shock-free operation, which must not be exceeded even under dynamic conditions.



Series	For linear drive	Max. moments (Nm)			Max. loads (N)	Maximum braking force at 6 bar (N) †	Mass of linear drive with guide (kg)		Mass * guide carriage (kg)
		Mx	My	Mz	Fy, Fz		with 0mm stroke	increase per 100mm stroke	
PL 16	OSP-P16	8	12	12	542	–	0.55	0.19	0.24
PL 25	OSP-P25	16	39	39	857	on request	1.65	0.40	0.75
PL 32	OSP-P32	29	73	73	1171	on request	3.24	0.62	1.18
PL 40	OSP-P40	57	158	158	2074	on request	4.35	0.70	1.70
PL 50	OSP-P50	111	249	249	3111	on request	7.03	0.95	2.50

\* Add the mass of the guide carriage to the mass to be cushioned.

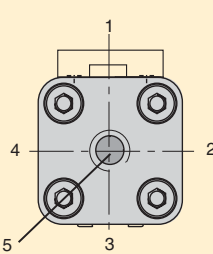

† Only for version with brake: Braking surface dry – oiled surface reduces the effective braking force.

**G**  
 Rodless Pneumatic Cylinders  
 OSP-P Series  
 P1X Series  
 P1Z Series  
 GDL Series



For inventory, lead times, and kit lookup, visit [www.pdnplu.com](http://www.pdnplu.com)

Ordering information for OSP-P rodless PROLINE pneumatic series

1-4	5-6	7	8	9	10	11	12-16	17	18	19	20	21	22	23	24	25		
<b>OSP</b>	<b>P</b>	<b>25</b>	<b>0</b>	<b>1</b>	<b>0</b>	<b>0</b>	<b>0</b>	<b>0</b>	<b>1</b>	<b>1</b>	<b>0</b>	<b>0</b>	<b>0</b>	<b>0</b>	<b>1</b>	<b>0</b>	<b>0</b>	
		<b>Bore</b> 16 25 32 40 50				<b>Lubrication</b> 0 Standard 1 Slow speed 4 Food 5 Clean room S Special	<b>Stroke</b> x x x x x			<b>Cushions / Stops</b> 0 Standard S Special			<b>Dovetail cover</b> 0 Standard X Without cover rail S Special				<b>Version</b> 0 Standard	
		<b>Piston style</b> 0 Standard 1 Tandem				<b>Seals</b> 0 Standard 1 Fluorocarbon			<b>Piston mounting</b> 0 None									
		<b>Porting configurations</b>			<b>Fasteners</b>					<b>Guides / Brakes</b>				<b>Mounting</b>				
		0 Standard (position #2) 1 End face (position #5) 2 Single end porting 3 Left stand (pos #2), Right end face (pos #5) 4 Right stand (pos #2), Left end face (pos #5) 6 Single end porting, end face A 3/2 way valve VOE, 24V = (25,32,40,50) B 3/2 way valve VOE, 220V~/110V = (25,32,40,50) C 3/2 way valve VOE, 48V = (25,32,40,50) E 3/2 way valve VOE, 110V = (25,32,40,50) S Special			0 Standard 1 Stainless steel 3 Xylan coated & stainless steel fasteners S Special					E PSXX/25 Powerslide (16,25) F PSXX/35 Powerslide (25,32) G PSXX/44 Powerslide (16,25) H PSXX/60 Powerslide (25,32,40) I PSXX/76 Powerslide (50)				0 None 1 A1 (16,25,32) 2 A2 (16,25,32) 3 A3 (25,32) 4 B1 (25,32) 6 B3 (16) 7 B4 (25,32) 8 B5 (32) 9 C1 (40,50) A C2 (40,50) B C3 (40,50) C C4 (40,50) <small>Note: Comes in pairs</small>				
		<small>Note: Single end porting on 16mm bore, then end caps cannot be rotated.</small>						<b>End Cap Port Position <math>\Delta</math></b>				<b>Additional carriages**</b>		<b>Switches <math>\diamond</math></b>				
								0 I+r 0° = in front (pos #2) 1 I+r 90° = underneath (pos #3) 2 I+r 180° = at the back (pos #4) 3 I+r 270° = same face as outerband (pos #2,1) 4 I 90° = underneath; r 0° = in front (pos #3,2) 5 I 180° = at the back; r 0° = in front (pos #4,2) 6 I 270° = same face as outerband; r 0° = in front (pos #1,2) 7 I 0° = in front; r 90° = underneath (pos #2,3) 8 I 180° = at the back; r 90° = underneath (pos #4,3) 9 I 270° = same face as outerband; r 90° = underneath (pos #1,3) A I 0° = in front; r 180° = at the back (pos #2,4) B I 90° = underneath; r 180° = at the back (pos #3,4) C I 270° = same face as outerband; r 180° = at the back (pos #1,4) D I 0° = in front; r 270° = same face as outerband (pos #2,1) E I 90° = underneath; r 270° = same face as outerband (pos #3,1) F I 180° = at the back; r 270° = same face as outerband (pos #4,1) S Special				0 None 2 Guide Carriage Proline PL 3 Guide Carriage Proline PL-AB 4 Guide Carriage Proline PL-MB M Guide Carriage Proline PL-MB without brake function		0 None 1 NO Reed, P8S-GRFDX2 2 NC Reed, P8S-GEFRX1 3 PNP P8S-GPCHX+4041 4 NPN P8S-GNCHX+4041 X 21240 SFI 0,1mm Y 21241 SFI 1mm Z 4650 SFA S Special <small><math>\diamond</math> Note: 2 switches will be supplied. For different quantity, please order as a separate line item.</small>				
								<small><math>\Delta</math> Note: End cap port position L = Left end cap, R = right end cap</small>				<b>Sensors</b> See section L for sensors.						

**G**  
 Rodless Pneumatic Cylinders  
 OSP-P Series  
 P1X Series  
 P1Z Series  
 GDL Series

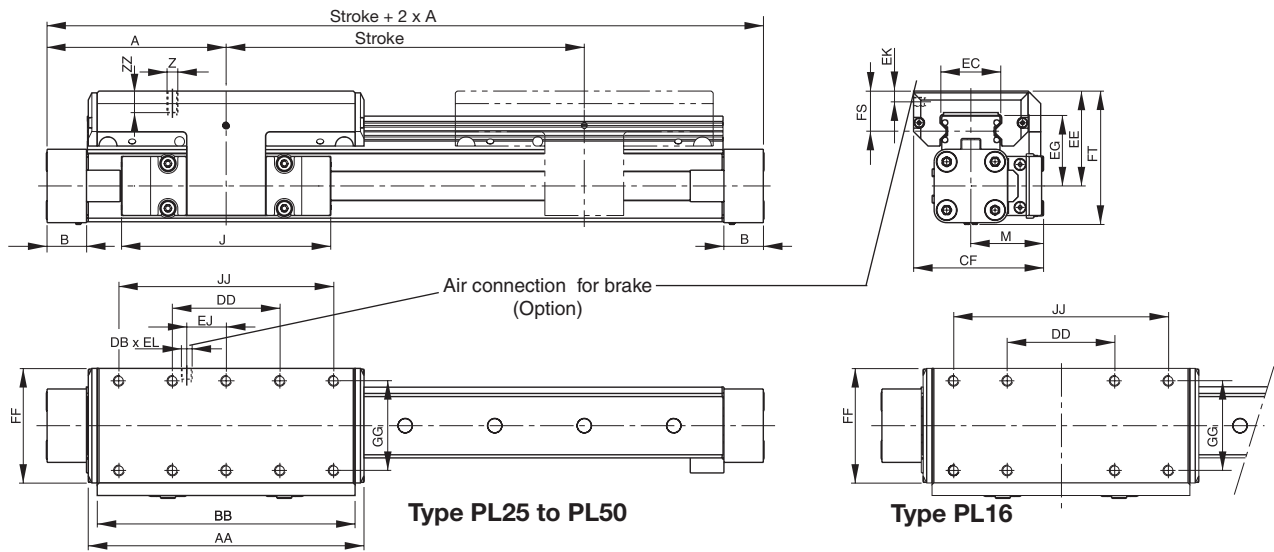


For inventory, lead time, and kit lookup, visit [www.pdnplu.com](http://www.pdnplu.com)

G55

**Parker Hannifin Corporation**  
Pneumatic Division  
Richland, Michigan  
[www.parker.com/pneumatics](http://www.parker.com/pneumatics)

**OSP-P PROLINE PL16, PL25, PL32, PL40, PL50**



**Dimension (mm)**

Series	A	B	J	M	Z	AA	BB	DB	DD	CF	EC	EE	EG	EJ	EK	EL	FF	FS	FT	GG	JJ	ZZ
PL16	65	14	69	31	M4	98	88	-	30	55	23	40	30	-	-	-	48	17	55	36	70	8
PL25	100	22	117	40.5	M6	154	144	M5	60	72.5	32.5	53	39	22	6	6	64	23	73.5	50	120	12
PL32	125	25.5	152	49	M6	197	187	M5	80	91	42	62	48	32	6	6	84	25	88	64	160	12
PL40	150	28	152	55	M6	232	222	M5	100	102	47	64	50.5	58	6	6	94	23.5	98.5	78	200	12
PL50	175	33	200	62	M6	276	266	M5	120	117	63	75	57	81	6	6	110	29	118.5	90	240	16

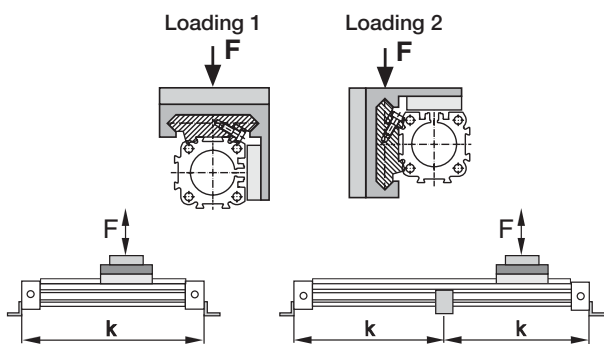
**Mid-Section Support**

(For versions, see page G83)

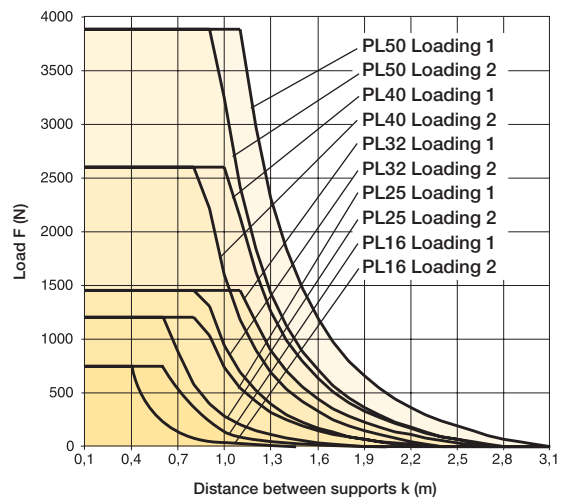
Mid-section supports are required from a certain stroke length to prevent excessive deflection and vibration of the linear drive. The diagrams

show the maximum permissible unsupported length in relation to loading. A distinction must be drawn between loading 1 and loading 2. Deflection of 0.5 mm max. between supports is permissible.

**Note:** For speeds  $v > 0.5$  m/s the distance between supports should not exceed 1 m.



**Permissible Unsupported Length**  
**PL16, PL25, PL32, PL40 and PL50**



**G**  
 Rodless Pneumatic Cylinders  
 OSP-P Series  
 P1X Series  
 P1Z Series  
 GDL Series



For inventory, lead times, and kit lookup, visit [www.pdnplu.com](http://www.pdnplu.com)

**Features**

**Multi-Brake Passive Brake with Aluminum Roller Guide PROLINE PL 25 to 50mm bore**

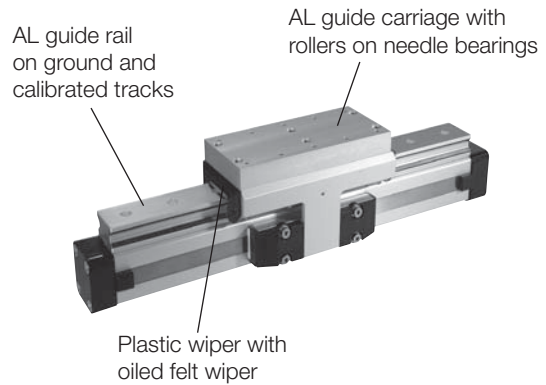
**Series MB-PL 25 to 50 for Linear-drive**

- Series OSP-P



**Features**

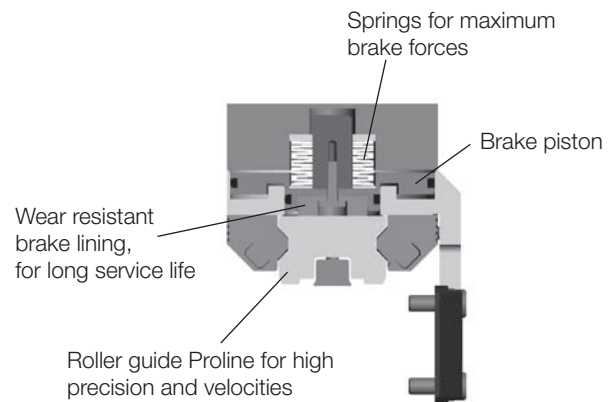
- Brake operated by spring actuation
- Brake release by pressurization
- Optional sensor to indicate brake lining wear
- Composite sealing system with plastic and felt wiper elements to remove dirt and lubricate the slideway
- Blocking function in case of pressure loss
- Intermediate stops possible



**Function**

The Multi-Brake is a passive device. When the air pressure is removed the brake is actuated and movement of the cylinder is blocked. The brake is released by pressurization.

The high friction, wear resistant brake linings allow the Multi-Brake to be used as a dynamic brake to stop cylinder movement in the shortest possible time. The powerful springs also allow the Multi-Brake to be used effectively in positioning applications.



**Loads, Forces and Moments**

The table shows the maximal permissible loads. If multiple moments and forces act upon the cylinder simultaneously, the following equation applies:

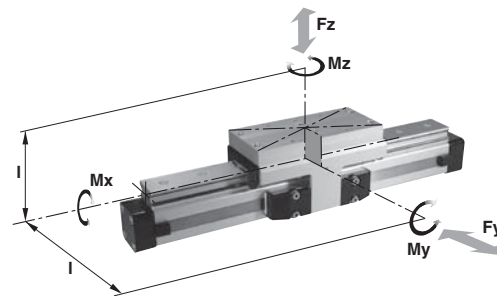
$$\frac{M_x}{M_{xmax}} + \frac{M_y}{M_{ymax}} + \frac{M_z}{M_{zmax}} + \frac{F_y}{F_{ymax}} + \frac{F_z}{F_{zmax}} \leq 1$$

**The sum of the loads should not exceed >1. With a load factor of less than 1, service life is 8000 km**

The table shows the maximum permissible values for light, shock-free operation, which must not be exceeded even under dynamic conditions.

Operating Pressure 4.5 - 8 bar.

A pressure of min. 4.5 bar release the brake.



Series	For linear drive	Max. moments (Nm)			Max. loads (N)		Mass of linear drive with guide (kg)		
		Mx	My	Mz	Fy, Fz	Max. braking force (N) †	With 0mm stroke	Increase per 100mm stroke	Mass* guide carriage (kg)
<b>MB-PL25</b>	OSP-P25	16	39	39	857	315	2.14	0.40	1.24
<b>MB-PL32</b>	OSP-P32	29	73	73	1171	490	4.08	0.62	2.02
<b>MB-PL40</b>	OSP-P40	57	158	158	2074	715	5.46	0.70	2.82
<b>MB-PL50</b>	OSP-P50	111	249	249	3111	1100	8.60	0.95	4.07

\* Add the mass of the guide carriage to the mass to be cushioned.

† Only for version with brake: Braking surface dry – oiled surface reduces the effective braking force.

**G**  
 Rodless Pneumatic Cylinders  
 OSP-P Series  
 P1X Series  
 P1Z Series  
 GDL Series

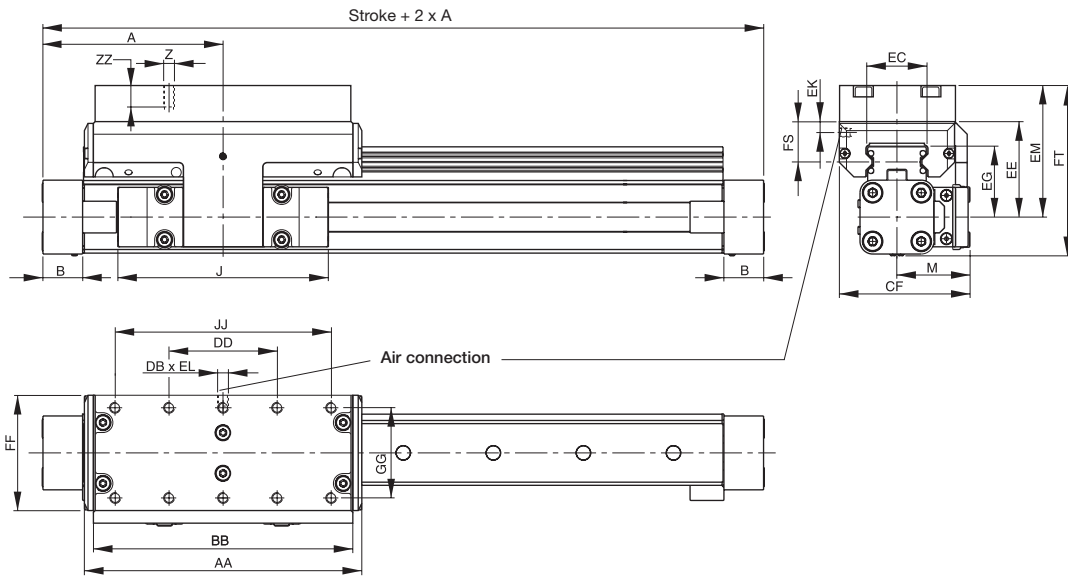


For inventory, lead time, and kit lookup, visit [www.pdnplu.com](http://www.pdnplu.com)

G57

**Parker Hannifin Corporation**  
 Pneumatic Division  
 Richland, Michigan  
[www.parker.com/pneumatics](http://www.parker.com/pneumatics)

**OSP-P with PROLINE Passive Brake MB-PL25, PL32, PL40, PL50**



**Dimension (mm)**

Series	A	B	J	M	Z	AA	BB	DB	DD	CF	EC	EE	EG	EK	EL	EM	FF	FS	FT	GG	JJ	ZZ
MB-PL25	100	22	117	40.5	M6	154	144	M5	60	72.5	32.5	53	39	9	5	73	64	23	93.5	50	120	12
MB-PL32	125	25.5	152	49	M6	197	187	G1/8	80	91	42	62	48	7	10	82	84	25	108	64	160	12
MB-PL40	150	28	152	55	M6	232	222	G1/8	100	102	47	64	50.5	6.5	10	84	94	23.5	118.5	78	200	12
MB-PL50	175	33	200	62	M6	276	266	G1/8	120	117	63	75	57	10	12	95	110	29	138.5	90	240	16

**Mid-Section Support**

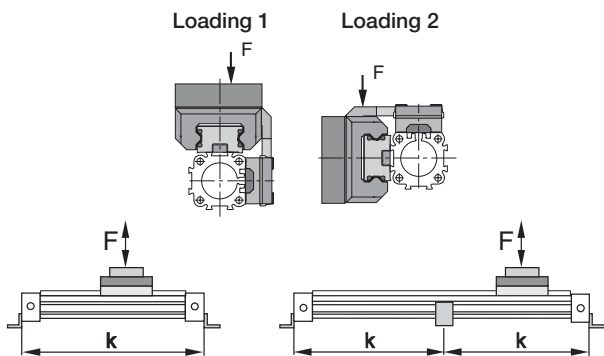
(for versions see page G83)

Mid-Section supports are required from a certain stroke length to prevent

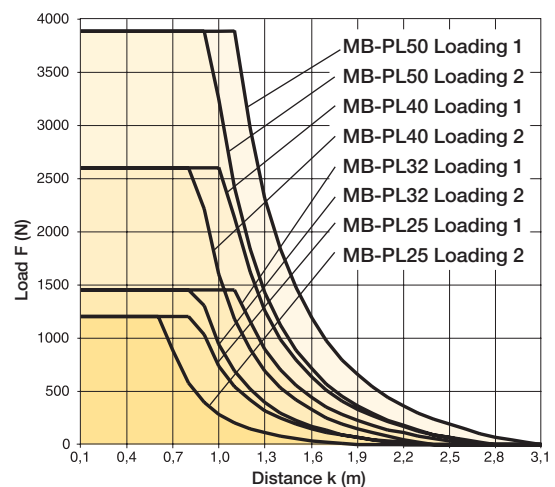
excessive deflection and vibration of the linear drive. The diagrams show the maximum permissible unsupported length in relation to loading.

A distinction must be drawn between loading 1 and loading 2. Deflection of 0.5 mm max. between supports is permissible.

**Note:** For speeds  $v > 0.5$  m/s the distance between supports should not exceed 1 m.



**Permissible Unsupported Length OSP-P  
 MB-PL25, MB-PL32, MB-PL40, MB-PL50**



**G**  
 Rodless Pneumatic Cylinders  
 OSP-P Series  
 P1X Series  
 P1Z Series  
 GDL Series



For inventory, lead times, and kit lookup, visit [www.pdnplu.com](http://www.pdnplu.com)

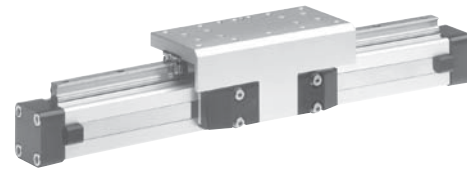


**Features**

**Recirculating Ball Bearing Guide STARLINE PL 16 to 50mm bore**

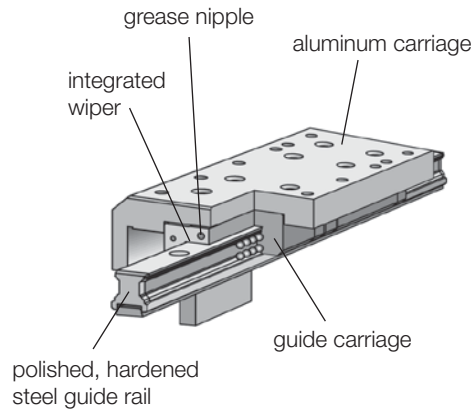
**Series PL 16 to 50 for Linear-drive**

- Series OSP-P



**Features**

- Polished and hardened steel guide rail
- For very high loads in all directions
- High precision
- Integrated wiper system
- Integrated grease nipples
- Any length of stroke up to 3700 mm
- Anodized aluminum guide carriage – dimensions compatible with OSP guides SLIDELINE and PROLINE
- Installation height (STL16 - 32) compatible with OSP guides SLIDELINE and PROLINE
- Maximum speed  
 STL16: v = 3 m/s  
 STL25 to 50: v = 5 m/s



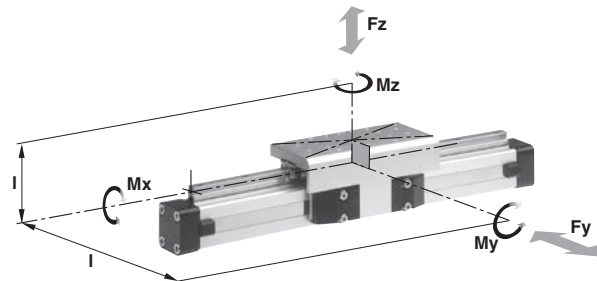
**Loads, Forces and Moments**

The table shows the maximum permissible loads. If multiple moments and forces act upon the cylinder simultaneously, the following equation applies:

$$\frac{M_x}{M_{xmax}} + \frac{M_y}{M_{ymax}} + \frac{M_z}{M_{zmax}} + \frac{F_y}{F_{ymax}} + \frac{F_z}{F_{zmax}} \leq 1$$

The sum of the loads should not exceed >1.

The table shows the maximum permissible values for light, shock-free operation, which must not be exceeded even under dynamic conditions.



Series	For linear drive	Max. moments (Nm)		Max. loads (N)			Mass of linear drive with guide (kg)		
		Mx	My	Mz	Fy	Fz	with 0mm stroke	increase per 100mm stroke	Mass * guide carriage (kg)
STL16	OSP-P16	15	30	30	1000	1000	0.598	0.210	0.268
STL25	OSP-P25	50	110	110	3100	3100	1.733	0.369	0.835
STL32	OSP-P32	62	160	160	3100	3100	2.934	0.526	1.181
STL40	OSP-P40	150	400	400	4000	7500	4.452	0.701	1.901
STL50	OSP-P50	210	580	580	4000	7500	7.361	0.936	2.880

\* Add the mass of the guide carriage to the mass to be cushioned.

**G**  
 Rodless Pneumatic Cylinders  
 OSP-P Series  
 P1X Series  
 P1Z Series  
 GDL Series



For inventory, lead time, and kit lookup, visit [www.pdnplu.com](http://www.pdnplu.com)

Ordering information for OSP-P rodless STARLINE pneumatic series

1-4	5-6	7	8	9	10	11	12-16	17	18	19	20	21	22	23	24	25
<b>OSP</b>	<b>P</b>	<b>25</b>	<b>0</b>	<b>1</b>	<b>0</b>	<b>0</b>	<b>01100</b>	<b>0</b>	<b>0</b>	<b>0</b>	<b>0</b>	<b>0</b>	<b>0</b>	<b>1</b>	<b>0</b>	<b>0</b>

<table border="1" style="width:100%; border-collapse: collapse;"> <tr><td colspan="2"><b>Bore</b></td></tr> <tr><td>16</td><td></td></tr> <tr><td>25</td><td></td></tr> <tr><td>32</td><td></td></tr> <tr><td>40</td><td></td></tr> <tr><td>50</td><td></td></tr> </table> <table border="1" style="width:100%; border-collapse: collapse;"> <tr><td colspan="2"><b>Piston style</b></td></tr> <tr><td>0</td><td>Standard</td></tr> <tr><td>1</td><td>Tandem</td></tr> </table> <table border="1" style="width:100%; border-collapse: collapse;"> <tr><td colspan="2"><b>Porting configurations</b></td></tr> <tr><td>0</td><td>Standard (position #2)</td></tr> <tr><td>1</td><td>End face (position #5)</td></tr> <tr><td>2</td><td>Single end porting</td></tr> <tr><td>3</td><td>Left stand (pos #2), Right end face (pos #5)</td></tr> <tr><td>4</td><td>Right stand (pos #2), Left end face (pos #5)</td></tr> <tr><td>6</td><td>Single end porting, end face</td></tr> <tr><td>A</td><td>3/2 way valve VOE, 24V = (25,32,40,50)</td></tr> <tr><td>B</td><td>3/2 way valve VOE, 220V~/110V = (25,32,40,50)</td></tr> <tr><td>C</td><td>3/2 way valve VOE, 48V = (25,32,40,50)</td></tr> <tr><td>E</td><td>3/2 way valve VOE, 110V = (25,32,40,50)</td></tr> <tr><td>S</td><td>Special</td></tr> </table>	<b>Bore</b>		16		25		32		40		50		<b>Piston style</b>		0	Standard	1	Tandem	<b>Porting configurations</b>		0	Standard (position #2)	1	End face (position #5)	2	Single end porting	3	Left stand (pos #2), Right end face (pos #5)	4	Right stand (pos #2), Left end face (pos #5)	6	Single end porting, end face	A	3/2 way valve VOE, 24V = (25,32,40,50)	B	3/2 way valve VOE, 220V~/110V = (25,32,40,50)	C	3/2 way valve VOE, 48V = (25,32,40,50)	E	3/2 way valve VOE, 110V = (25,32,40,50)	S	Special	<table border="1" style="width:100%; border-collapse: collapse;"> <tr><td colspan="2"><b>Lubrication</b></td></tr> <tr><td>0</td><td>Standard</td></tr> <tr><td>1</td><td>Slow speed</td></tr> <tr><td>4</td><td>Food</td></tr> <tr><td>5</td><td>Clean room</td></tr> <tr><td>S</td><td>Special</td></tr> </table> <table border="1" style="width:100%; border-collapse: collapse;"> <tr><td colspan="2"><b>Seals</b></td></tr> <tr><td>0</td><td>Standard</td></tr> <tr><td>1</td><td>Fluorocarbon</td></tr> </table> <table border="1" style="width:100%; border-collapse: collapse;"> <tr><td colspan="2"><b>Fasteners</b></td></tr> <tr><td>0</td><td>Standard</td></tr> <tr><td>1</td><td>Stainless steel</td></tr> <tr><td>3</td><td>Xylan coated &amp; stainless steel fasteners</td></tr> <tr><td>S</td><td>Special</td></tr> </table>	<b>Lubrication</b>		0	Standard	1	Slow speed	4	Food	5	Clean room	S	Special	<b>Seals</b>		0	Standard	1	Fluorocarbon	<b>Fasteners</b>		0	Standard	1	Stainless steel	3	Xylan coated & stainless steel fasteners	S	Special	<table border="1" style="width:100%; border-collapse: collapse;"> <tr><td colspan="2"><b>Stroke</b></td></tr> <tr><td colspan="2">x x x x x</td></tr> </table> <table border="1" style="width:100%; border-collapse: collapse;"> <tr><td colspan="2"><b>Piston mounting</b></td></tr> <tr><td>0</td><td>None</td></tr> </table> <table border="1" style="width:100%; border-collapse: collapse;"> <tr><td colspan="2"><b>Cushions / Stops</b></td></tr> <tr><td>0</td><td>Standard</td></tr> <tr><td>2</td><td>VS soft left</td></tr> <tr><td>3</td><td>VS hard left</td></tr> <tr><td>4</td><td>VS soft right</td></tr> <tr><td>5</td><td>VS hard right</td></tr> <tr><td>6</td><td>VS soft both sides</td></tr> <tr><td>7</td><td>VS hard both sides</td></tr> <tr><td>S</td><td>Special</td></tr> </table> <table border="1" style="width:100%; border-collapse: collapse;"> <tr><td colspan="2"><b>Guides / Brakes</b></td></tr> <tr><td>B</td><td>STL Starline</td></tr> </table>	<b>Stroke</b>		x x x x x		<b>Piston mounting</b>		0	None	<b>Cushions / Stops</b>		0	Standard	2	VS soft left	3	VS hard left	4	VS soft right	5	VS hard right	6	VS soft both sides	7	VS hard both sides	S	Special	<b>Guides / Brakes</b>		B	STL Starline	<table border="1" style="width:100%; border-collapse: collapse;"> <tr><td colspan="2"><b>Dovetail cover</b></td></tr> <tr><td>0</td><td>Standard</td></tr> <tr><td>X</td><td>Without cover rail</td></tr> <tr><td>S</td><td>Special</td></tr> </table> <table border="1" style="width:100%; border-collapse: collapse;"> <tr><td colspan="2"><b>Mounting</b></td></tr> <tr><td>0</td><td>None</td></tr> <tr><td>4</td><td>B1 (25,32)</td></tr> <tr><td>5</td><td>B2 (16,25,32)</td></tr> <tr><td>6</td><td>B3 (16)</td></tr> <tr><td>7</td><td>B4 (25,32)</td></tr> <tr><td>8</td><td>B5 (32)</td></tr> <tr><td>9</td><td>C1 (40,50)</td></tr> <tr><td>A</td><td>C2 (40,50)</td></tr> <tr><td>B</td><td>C3 (40,50)</td></tr> <tr><td>C</td><td>C4 (40,50)</td></tr> </table>	<b>Dovetail cover</b>		0	Standard	X	Without cover rail	S	Special	<b>Mounting</b>		0	None	4	B1 (25,32)	5	B2 (16,25,32)	6	B3 (16)	7	B4 (25,32)	8	B5 (32)	9	C1 (40,50)	A	C2 (40,50)	B	C3 (40,50)	C	C4 (40,50)
<b>Bore</b>																																																																																																																																					
16																																																																																																																																					
25																																																																																																																																					
32																																																																																																																																					
40																																																																																																																																					
50																																																																																																																																					
<b>Piston style</b>																																																																																																																																					
0	Standard																																																																																																																																				
1	Tandem																																																																																																																																				
<b>Porting configurations</b>																																																																																																																																					
0	Standard (position #2)																																																																																																																																				
1	End face (position #5)																																																																																																																																				
2	Single end porting																																																																																																																																				
3	Left stand (pos #2), Right end face (pos #5)																																																																																																																																				
4	Right stand (pos #2), Left end face (pos #5)																																																																																																																																				
6	Single end porting, end face																																																																																																																																				
A	3/2 way valve VOE, 24V = (25,32,40,50)																																																																																																																																				
B	3/2 way valve VOE, 220V~/110V = (25,32,40,50)																																																																																																																																				
C	3/2 way valve VOE, 48V = (25,32,40,50)																																																																																																																																				
E	3/2 way valve VOE, 110V = (25,32,40,50)																																																																																																																																				
S	Special																																																																																																																																				
<b>Lubrication</b>																																																																																																																																					
0	Standard																																																																																																																																				
1	Slow speed																																																																																																																																				
4	Food																																																																																																																																				
5	Clean room																																																																																																																																				
S	Special																																																																																																																																				
<b>Seals</b>																																																																																																																																					
0	Standard																																																																																																																																				
1	Fluorocarbon																																																																																																																																				
<b>Fasteners</b>																																																																																																																																					
0	Standard																																																																																																																																				
1	Stainless steel																																																																																																																																				
3	Xylan coated & stainless steel fasteners																																																																																																																																				
S	Special																																																																																																																																				
<b>Stroke</b>																																																																																																																																					
x x x x x																																																																																																																																					
<b>Piston mounting</b>																																																																																																																																					
0	None																																																																																																																																				
<b>Cushions / Stops</b>																																																																																																																																					
0	Standard																																																																																																																																				
2	VS soft left																																																																																																																																				
3	VS hard left																																																																																																																																				
4	VS soft right																																																																																																																																				
5	VS hard right																																																																																																																																				
6	VS soft both sides																																																																																																																																				
7	VS hard both sides																																																																																																																																				
S	Special																																																																																																																																				
<b>Guides / Brakes</b>																																																																																																																																					
B	STL Starline																																																																																																																																				
<b>Dovetail cover</b>																																																																																																																																					
0	Standard																																																																																																																																				
X	Without cover rail																																																																																																																																				
S	Special																																																																																																																																				
<b>Mounting</b>																																																																																																																																					
0	None																																																																																																																																				
4	B1 (25,32)																																																																																																																																				
5	B2 (16,25,32)																																																																																																																																				
6	B3 (16)																																																																																																																																				
7	B4 (25,32)																																																																																																																																				
8	B5 (32)																																																																																																																																				
9	C1 (40,50)																																																																																																																																				
A	C2 (40,50)																																																																																																																																				
B	C3 (40,50)																																																																																																																																				
C	C4 (40,50)																																																																																																																																				

<b>End Cap Port Position <math>\Delta</math></b>	
0	l+r 0° = in front (pos #2)
1	l+r 90° = underneath (pos #3)
2	l+r 180° = at the back (pos #4)
3	l+r 270° = same face as outerband (pos #2,1)
4	l 90° = underneath; r 0° = in front (pos #3,2)
5	l 180° = at the back; r 0° = in front (pos #4,2)
6	l 270° = same face as outerband; r 0° = in front (pos #1,2)
7	l 0° = in front; r 90° = underneath (pos #2,3)
8	l 180° = at the back; r 90° = underneath (pos #4,3)
9	l 270° = same face as outerband; r 90° = underneath (pos #1,3)
A	l 0° = in front; r 180° = at the back (pos #2,4)
B	l 90° = underneath; r 180° = at the back (pos #3,4)
C	l 270° = same face as outerband; r 180° = at the back (pos #1,4)
D	l 0° = in front; r 270° = same face as outerband (pos #2,1)
E	l 90° = underneath; r 270° = same face as outerband (pos #3,1)
F	l 180° = at the back; r 270° = same face as outerband (pos #4,1)
S	Special

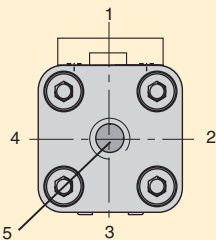
<b>Additional carriages**</b>	
0	None
B	Guide Carriage Starline STL

<b>Switches <math>\diamond</math></b>	
0	None
1	NO Reed, P8S-GRFDX2
2	NC Reed, P8S-GEFRX1
3	PNP P8S-GPCHX+4041
4	NPN P8S-GNCHX+4041
X	21240 SFI 0,1mm
Y	21241 SFI 1mm
Z	4650 SFA
S	Special

$\diamond$  Note: 2 switches will be supplied. For different quantity, please order as a separate line item.

Note: Single end porting on 16mm bore, then end caps cannot be rotated.



Note: Position #2 is the standard location.

$\Delta$  Note: End cap port position  
L = Left end cap, R = right end cap

**Sensors**

See section L for sensors.



**G** Rodless Pneumatic Cylinders  
 OSP-P Series  
 P1X Series  
 P1Z Series  
 GDL Series

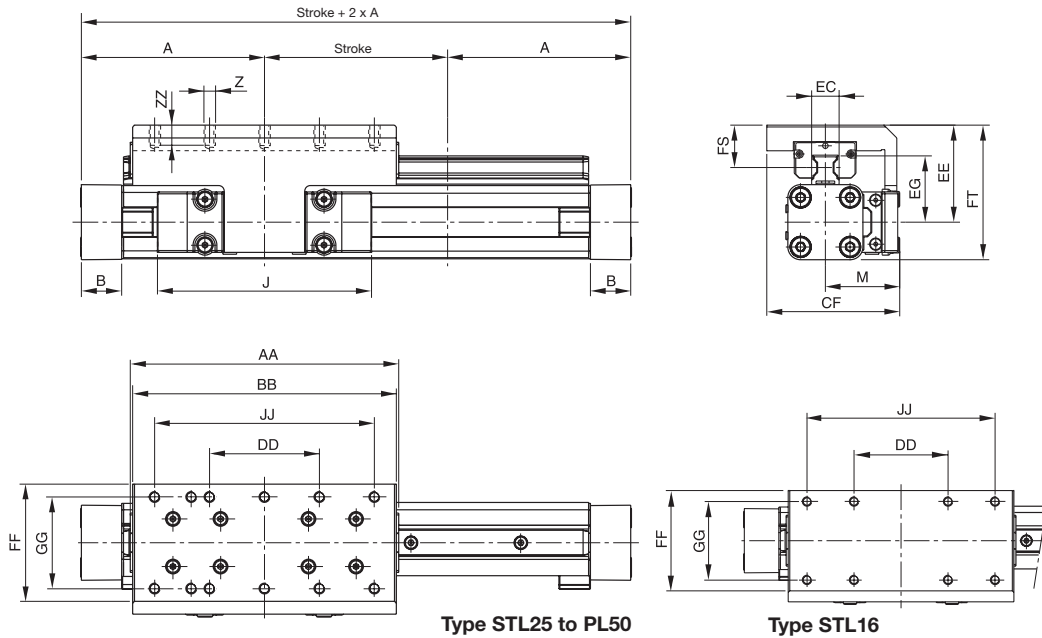


For inventory, lead times, and kit lookup, visit [www.pdnplu.com](http://www.pdnplu.com)

G60

**Parker Hannifin Corporation**  
 Pneumatic Division  
 Richland, Michigan  
[www.parker.com/pneumatics](http://www.parker.com/pneumatics)

**OSP-P with STARLINE Recirculating Ball Bearing Guide STL16, STL25, STL32, STL40, STL50**



**Dimension (mm)**

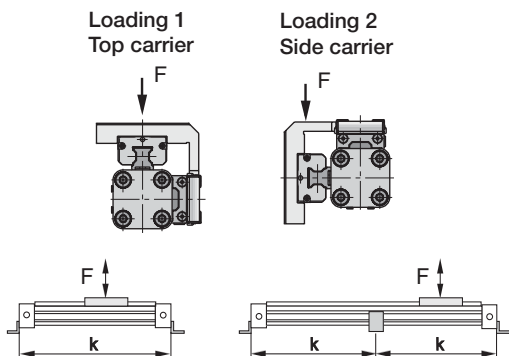
Series	A	B	J	M	Z	AA	BB	CF	DD	EC	EE	EG	FF	FS	FT	GG	JJ	ZZ
STL16	65	14	69	31	M4	93	90	55	30	15	40	24.6	48	18	55	36	70	8
STL25	100	22	117	40.5	M6	146.6	144	72.5	60	15	53	36.2	64	23.2	73.5	50	120	12
STL32	125	25.5	152	49	M6	186.6	184	91	80	15	62	42.2	84	26.2	88	64	160	12
STL40	150	28	152	55	M6	231	226	102	100	20	72	51.6	94	28.5	106.5	78	200	12
STL50	175	33	200	62	M6	270.9	266	117	120	23	85	62.3	110	32.5	128.5	90	240	16

**Mid-Section Support**

(For versions, see pages G83-G84)

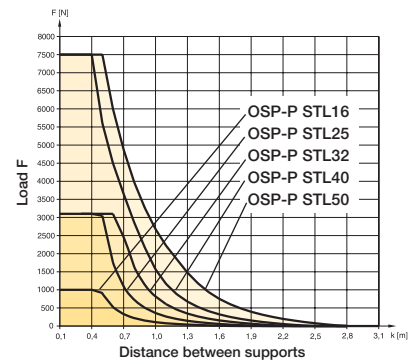
Mid-section supports are required from a certain stroke length to prevent excessive deflection and vibration of the linear drive. The diagrams show the maximum permissible unsupported length in relation to loading. A distinction must be drawn between loading 1 and loading 2. Deflection of 0.5 mm max. between supports is permissible.

**Note:** For speeds  $v > 0.5$  m/s the distance between supports should not exceed 1 m.



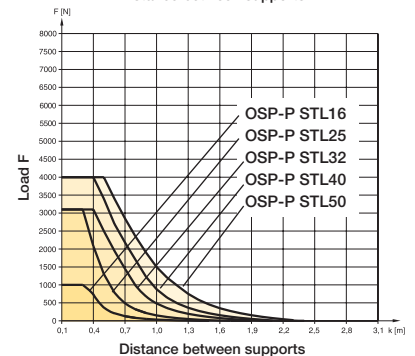
**Permissible Unsupported Length STL16 to STL50**

**Loading 1 Top carrier**



**Permissible Unsupported Length STL16 to STL50**

**Loading 2 Side carrier**



**Variable Stop Type VS16 to VS50**

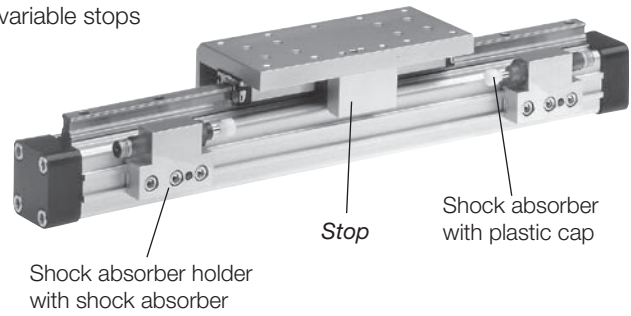
The variable stop Type VS provides simple stroke limitation. It can be retrofitted and positioned anywhere along the stroke length.

For every cylinder diameter two types of shock absorber are available – see “Shock Absorber Selection” below.

Mid-section supports and magnetic switches can still be fitted on the same side as the variable stop.

Depending on the application, two variable stops can be fitted if required.

Arrangement with two variable stops



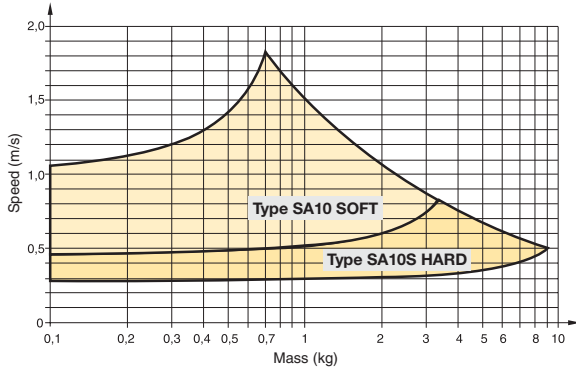
**Shock Absorber Selection**

The shock absorber is selected in dependence on the mass and speed.

The mass of the carrier itself must be taken into account.

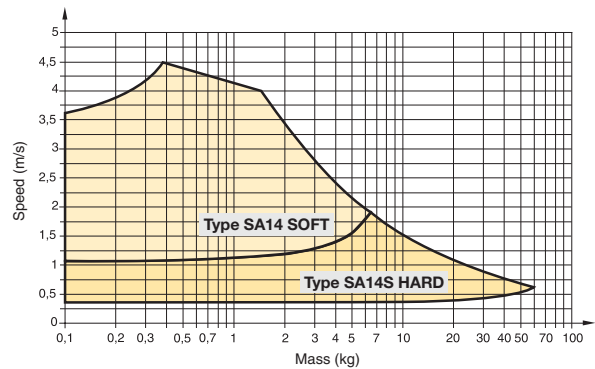
**Series OSP-STL16**

The values relate to an effective driving force of 78 N (6 bar)



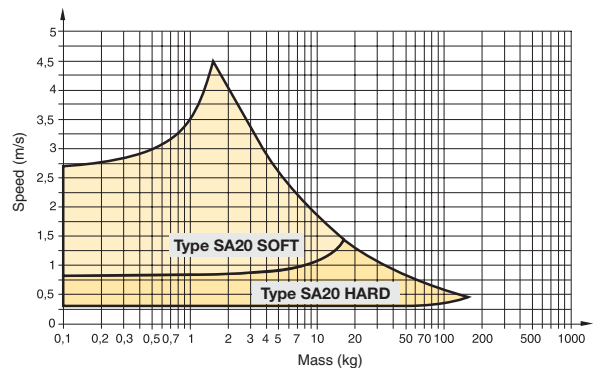
**Series OSP-STL32**

The values relate to an effective driving force of 420 N (6 bar)



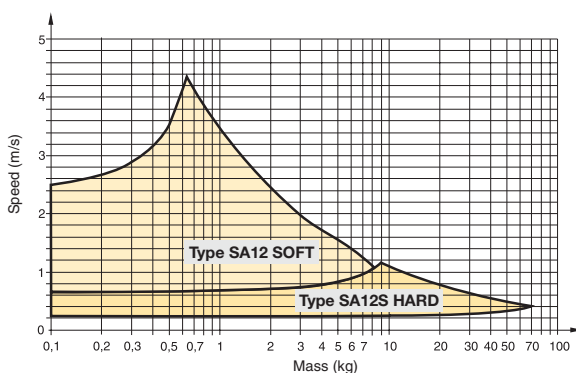
**Series OSP-STL40**

The values relate to an effective driving force of 640 N (6 bar)



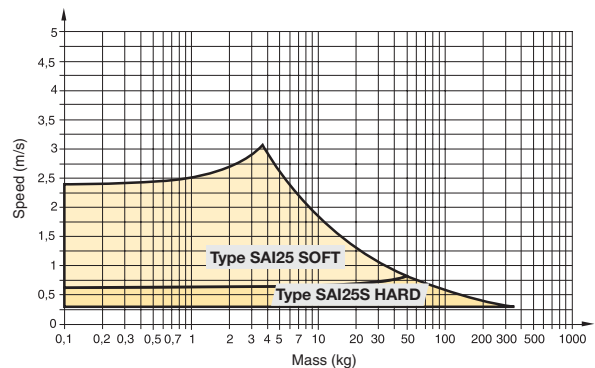
**Series OSP-STL25**

The values relate to an effective driving force of 250 N (6 bar)



**Series OSP-STL50**

The values relate to an effective driving force of 1000 N (6 bar)

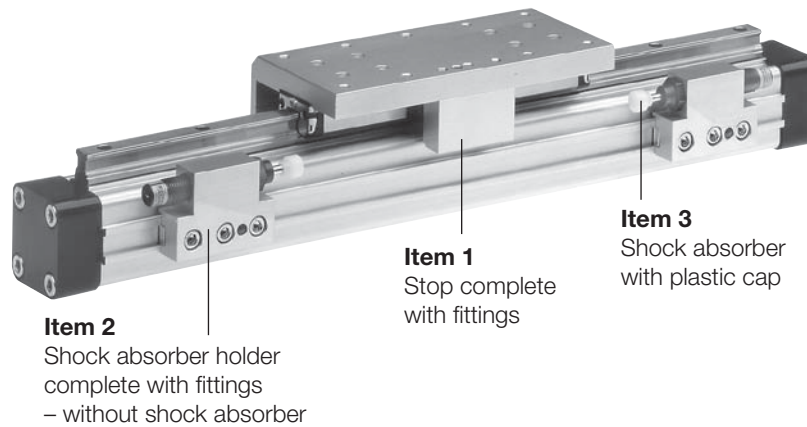


<b>G</b> Rodless Pneumatic Cylinders	OSP-P
	Series
	P1X
	Series
	P1Z
Series	
GDL	
Series	



For inventory, lead times, and kit lookup, visit [www.pdnplu.com](http://www.pdnplu.com)

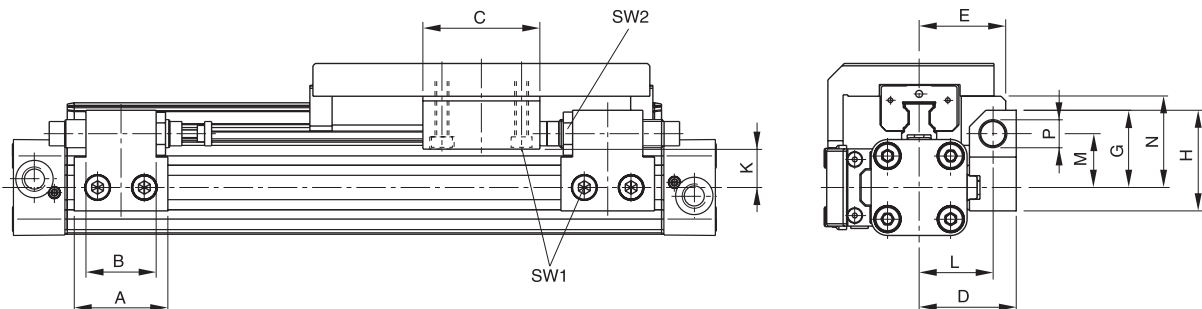
Ordering Information – Variable Stop Type VS16 to VS50



Item	Description	Size	VS16		VS25		VS32		VS40		VS50	
		Type	Part number	Type	Part number	Type	Part number	Type	Part number	Type	Part number	
1	Stop, complete	-	21196FIL	-	21197FIL	-	21198FIL	-	21199FIL	-	21200FIL	
2	Shock absorber holder, complete	-	21201FIL	-	21202FIL	-	21203FIL	-	21204FIL	-	21205FIL	
3 *	Shock absorber, standard	SA10	MC25M	SA12	MC75M-1	SA14	MC150M-B	SA20	MC225M	SAI25	MC600M	
	Shock absorber, version S	SA10S	MC25MH	SA12S	MC75M-2	SA14S	MC150MH-B	SA20S	MC225MH	SAI25S	MC600MH	

\* Shock absorber with plastic cap

Dimension – Variable Stop Type VS16 to VS50



Series	Type	A	B	C	D	E	G	H	K	L	M	N	P	SW1	SW2
OSP-STL16	VS16	30	14	25	33	30	28	38	16.2	25.5	20.5	30	M10x1	4	12.5
OSP-STL25	VS25	40	30	50	41.5	37	33	43	18	31.5	23	39	M12x1	5	16
OSP-STL32	VS32	60	40	50	45.5	42	35	45	19	35.5	25	48	M14x1.5	5	17
OSP-STL40	VS40	84	52	60	64	59	48	63	25.6	50	34	58.6	M20x1.5	5	24
OSP-STL50	VS50	84	-	60	75	69	55	70	26.9	57	38	66.9	M25x1.5	5	30



Rodless Pneumatic Cylinders

OSP-P Series

P1X Series

P1Z Series

GDL Series



For inventory, lead time, and kit lookup, visit [www.pdnplu.com](http://www.pdnplu.com)

G63

Parker Hannifin Corporation  
Pneumatic Division  
Richland, Michigan  
[www.parker.com/pneumatics](http://www.parker.com/pneumatics)

**Features**

**Recirculating Ball Bearing Guide KF 16 to 50mm bore**

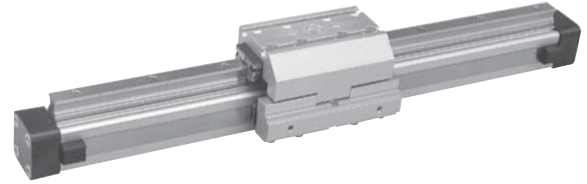
**Series KF16 to KF50 for Linear-drive**

- Series OSP-P CLASSIC



**Features**

- Anodized aluminum guide carriage, the mounting dimensions correspond to FESTO Type: DGPL-KF
- Polished and hardened steel guide rail
- For high loads in all directions
- High precision
- Integrated wiper system
- Integrated grease nipples
- Any length of stroke up to 3700 mm
- Maximum speed  
 KF16, KF40: v = 3 m/s  
 KF25, KF32, KF50: v = 5 m/s



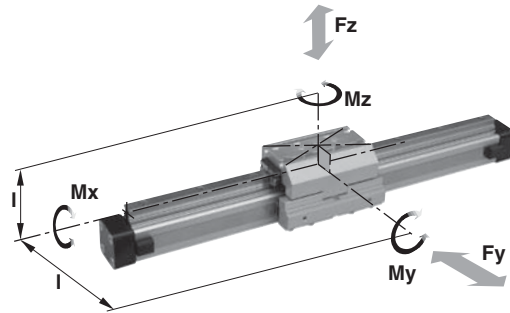
**Loads, Forces and Moments**

The table shows the maximum permissible loads. If multiple moments and forces act upon the cylinder simultaneously, the following equation applies:

$$\frac{M_x}{M_{xmax}} + \frac{M_y}{M_{ymax}} + \frac{M_z}{M_{zmax}} + \frac{F_y}{F_{ymax}} + \frac{F_z}{F_{zmax}} \leq 1$$

**The sum of the loads should not exceed >1.**

The table shows the maximum permissible values for light, shock-free operation, which must not be exceeded even under dynamic conditions.



Series	for linear drive	Max. Moments (Nm)			Max. Load (N)		Mass of drive with guide (kg)		Mass * guide carriage (kg)	Groove stone thread size
		Mx	My	Mz	Fy	Fz	with 0mm stroke	increase per 100mm stroke		
KF16	OSP-P16	12	25	25	1000	1000	0.558	0.21	0.228	–
KF25	OSP-P25	35	90	90	3100	3100	1.522	0.369	0.607	M5
KF32	OSP-P32	44	133	133	3100	3100	2.673	0.526	0.896	M5
KF40	OSP-P40	119	346	346	4000	7100	4.167	0.701	1.531	M6
KF50	OSP-P50	170	480	480	4000	7500	7.328	0.936	2.760	M8

\*Add the mass of the guide carriage to the mass to be cushioned.

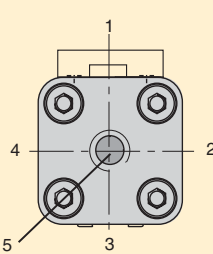
**G**  
 Rodless Pneumatic Cylinders  
 OSP-P Series  
 P1X Series  
 P1Z Series  
 GDL Series



For inventory, lead times, and kit lookup, visit [www.pdnplu.com](http://www.pdnplu.com)

Ordering information for OSP-P rodless KF pneumatic series


1-4	5-6	7	8	9	10	11	12-16	17	18	19	20	21	22	23	24	25							
<b>OSP</b>	<b>P</b>	<b>25</b>	<b>0</b>	<b>1</b>	<b>0</b>	<b>0</b>	<b>0</b>	<b>0</b>	<b>0</b>	<b>0</b>	<b>0</b>	<b>0</b>	<b>0</b>	<b>1</b>	<b>0</b>	<b>0</b>							
		<b>Bore</b>				<b>Lubrication</b>	<b>Stroke</b>				<b>Piston mounting</b>	<b>Dovetail cover</b>			<b>Version</b>								
		16 25 32 40 50				0 Standard 1 Slow speed 4 Food 5 Clean room S Special	xxxxx				0 None	0 Standard X Without cover rail S Special			0 Standard								
		<b>Piston style</b>				<b>Seals</b>				<b>Cushions / Stops</b>				<b>Mounting</b>									
		0 Standard 1 Tandem				0 Standard 1 Fluorocarbon				0 Standard 2 VS soft left 3 VS hard left 4 VS soft right 5 VS hard right 6 VS soft both sides 7 VS hard both sides S Special				0 None 4 B1 (25,32) 5 B2 (16,25,32) 6 B3 (16) 8 B5 (32) 9 C1 (40,50) A C2 (40,50) B C3 (40,50) C C4 (40,50) D HP (25,32,40,50)									
		<b>Porting configurations</b>				<b>Fasteners</b>				<b>Guides / Brakes</b>													
		0 Standard (position #2) 1 End face (position #5) 2 Single end porting 3 Left stand (pos #2), Right end face (pos #5) 4 Right stand (pos #2), Left end face (pos #5) 6 Single end porting, end face A 3/2 way valve VOE, 24V = (25,32,40,50) B 3/2 way valve VOE, 220V~/110V = (25,32,40,50) C 3/2 way valve VOE, 48V = (25,32,40,50) E 3/2 way valve VOE, 110V = (25,32,40,50) S Special				0 Standard 1 Stainless steel 3 Xylan coated & stainless steel fasteners S Special				C KF													
								<b>End Cap Port Position <math>\Delta</math></b>															
								0 l+r 0° = in front (pos #2) 1 l+r 90° = underneath (pos #3) 2 l+r 180° = at the back (pos #4) 3 l+r 270° = same face as outerband (pos #2,1) 4 l 90° = underneath; r 0° = in front (pos #3,2) 5 l 180° = at the back; r 0° = in front (pos #4,2) 6 l 270° = same face as outerband; r 0° = in front (pos #1,2) 7 l 0° = in front; r 90° = underneath (pos #2,3) 8 l 180° = at the back; r 90° = underneath (pos #4,3) 9 l 270° = same face as outerband; r 90° = underneath (pos #1,3) A l 0° = in front; r 180° = at the back (pos #2,4) B l 90° = underneath; r 180° = at the back (pos #3,4) C l 270° = same face as outerband; r 180° = at the back (pos #1,4) D l 0° = in front; r 270° = same face as outerband (pos #2,1) E l 90° = underneath; r 270° = same face as outerband (pos #3,1) F l 180° = at the back; r 270° = same face as outerband (pos #4,1) S Special															
											<b>Additional carriages**</b>												
											0 None B Guide Carriage KF												
														<b>Switches <math>\diamond</math></b>									
														0 None 1 NO Reed, P8S-GRFDX2 2 NC Reed, P8S-GEFRX1 3 PNP P8S-GPCHX+4041 4 NPN P8S-GNCHX+4041 X 21240 SFI 0,1mm Y 21241 SFI 1mm Z 4650 SFA S Special									
														$\diamond$ Note: 2 switches will be supplied. For different quantity, please order as a separate line item.									



**Note: Position #2 is the standard location.**

$\Delta$  Note: End cap port position  
L = Left end cap, R = right end cap

**Sensors**  
See section L for sensors.



**G**

Rodless Pneumatic Cylinders

---

OSP-P Series

---

P1X Series

---

P1Z Series

---

GDL Series

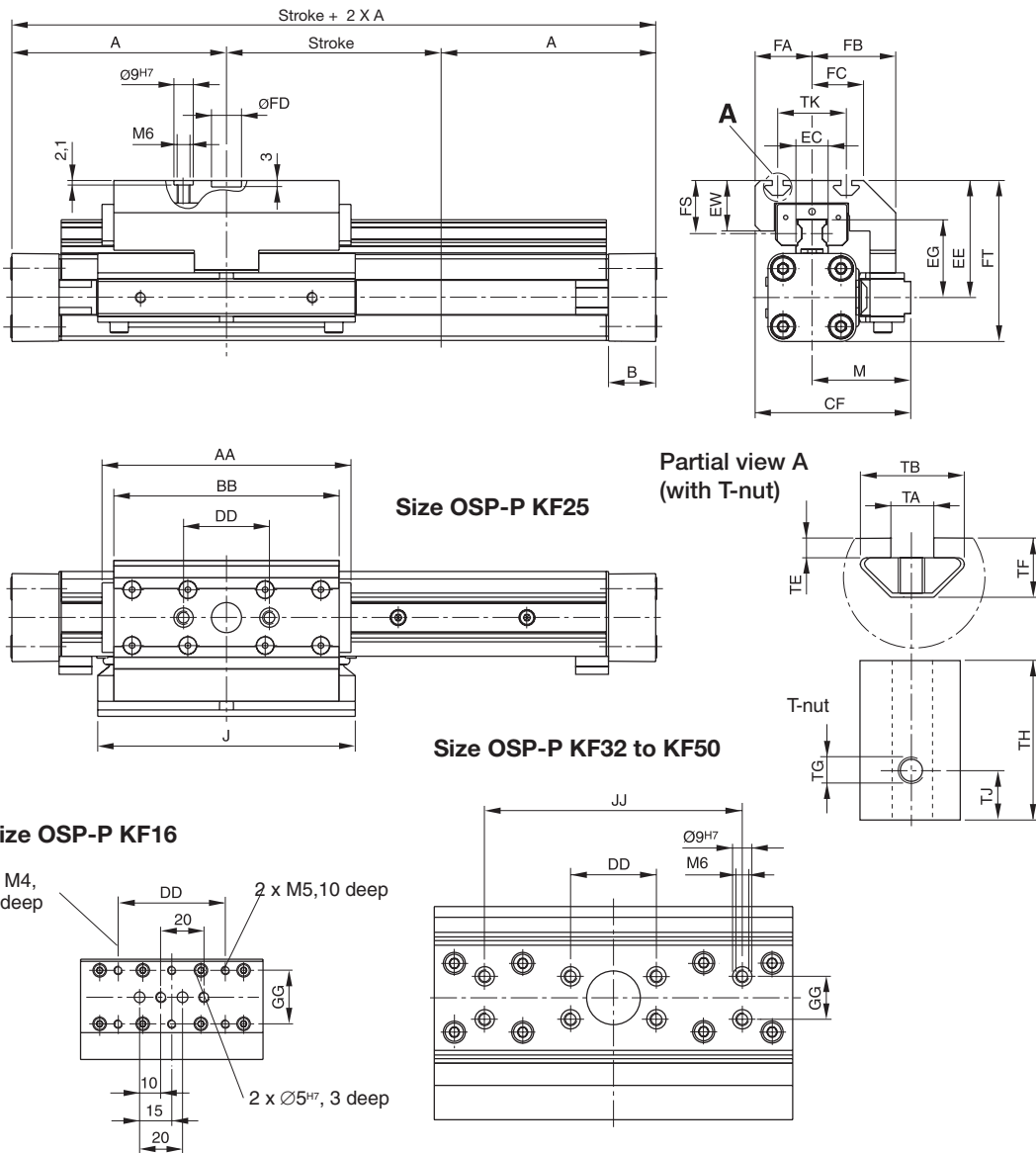


For inventory, lead time, and kit lookup, visit [www.pdnplu.com](http://www.pdnplu.com)

G65

**Parker Hannifin Corporation**  
Pneumatic Division  
Richland, Michigan  
[www.parker.com/pneumatics](http://www.parker.com/pneumatics)

**Series OSP-P KF16 to KF50**



**Dimension (mm) Series OSP-P KF16, KF25, KF32, KF40, KF50**

Series	A	B	J	AA	BB	CF	DD	EC	EE	EG	EW	JJ	GG	M
KF16	65	14	76	93	85	48	50	15	41	24.6	10	-	25	30
KF25	100	22	120	120.2	105	72.5	40	15	54.5	36.2	23.5	-	-	46
KF32	125	25.5	160	146.2	131	93.8	40	15	60.5	42.2	23.5	-	20	59.8
KF40	150	28	150	188.5	167	103.3	40	20	69.5	51.6	26.5	120	20	60.8
KF50	175	33	180	220.2	202	121	40	23	90.5	62.3	32.5	120	40	69

Series	FA	FB	FC	FD	FT	FS	TA	TB	TE	TF	TG	TH	TJ	TK
KF16	17.7	29	16.5	-	56	19	-	-	-	-	-	-	-	-
KF25	26.5	39	24	14 G7	75	24.7	5	12.1	2.3	6.9	M5	11.5	4	32
KF32	34	53.8	34	25 G7	86.5	24.7	5	12.1	1.8	6.4	M5	11.5	4	47
KF40	42.5	56.8	41	25 G7	104	26	6	12.8	1.8	8.4	M6	17	5.5	55
KF50	52	65	50	25 G7	134	38	8	21.1	4.5	12.5	M8	23	7.5	72

**G**  
 Rodless Pneumatic Cylinders  
 OSP-P Series  
 P1X Series  
 P1Z Series  
 GDL Series



For inventory, lead times, and kit lookup, visit [www.pdnplu.com](http://www.pdnplu.com)

G66

**Parker Hannifin Corporation**  
 Pneumatic Division  
 Richland, Michigan  
[www.parker.com/pneumatics](http://www.parker.com/pneumatics)



**Mid-Section Support**

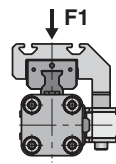
(For versions, see pages G84-G85)

Mid-section supports are required from a certain stroke length to prevent excessive deflection and vibration of the linear drive. The diagrams show the maximum permissible unsupported length in relation to loading. A distinction must be drawn between loading 1 and loading 2.

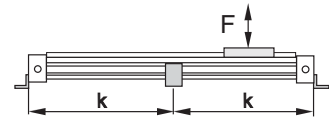
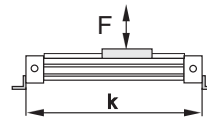
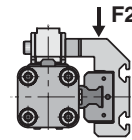
Deflection of 0.5 mm max. between supports is permissible.

**Note:** For speeds  $v > 0.5$  m/s the distance between supports should not exceed 1 m.

**Loading 1  
Top carrier**

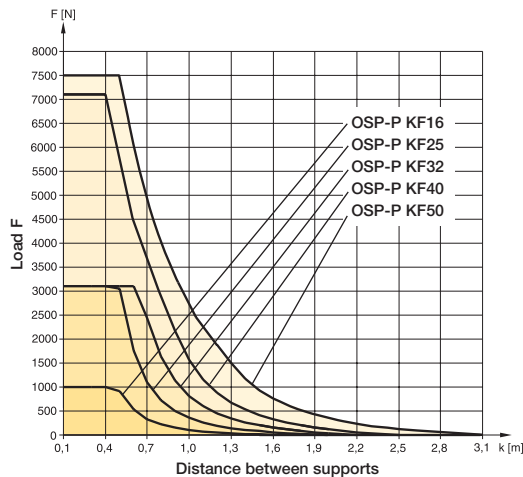


**Loading 2  
Side carrier**



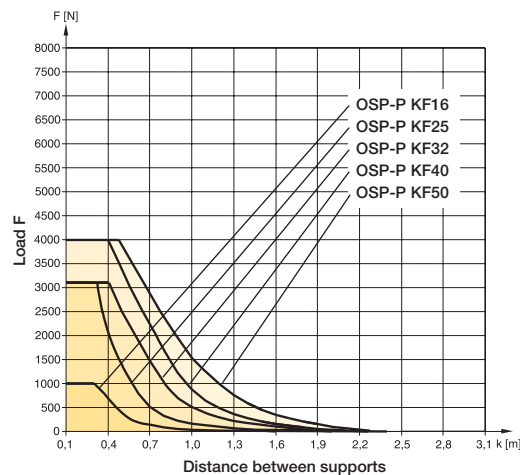
**Permissible Unsupported Length OSP-P KF16 to KF50  
Loading 1 – Top carrier**

Loading 1 – Top carrier



**Permissible Unsupported Length OSP-P KF16 to KF50  
Loading 2 – Side carrier**

Loading 2 – Side carrier



For inventory, lead time, and kit lookup, visit [www.pdnplu.com](http://www.pdnplu.com)

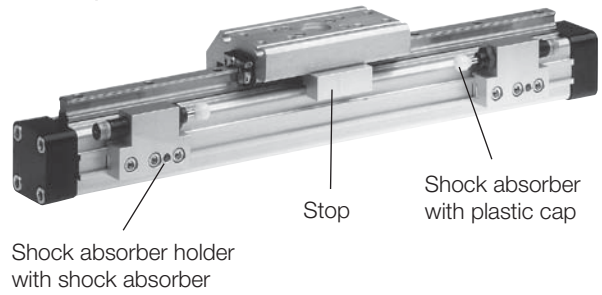
**Variable Stop Type VS16 to VS50**

The variable stop Type VS provides simple stroke limitation. It can be retrofitted and positioned anywhere along the stroke length. For every cylinder diameter two types of shock absorber are available – see “Shock Absorber Selection” below.

Mid-section supports and magnetic switches can still be fitted on the same side as the variable stop.

Depending on the application, two variable stops can be fitted if required.

**Arrangement with two variable stops**



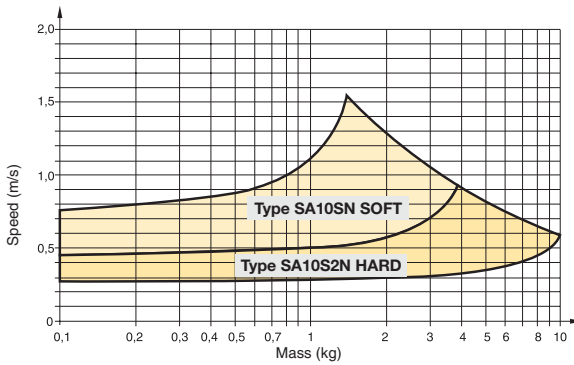
Shock absorber holder with shock absorber

**Shock Absorber Selection**

The shock absorber is selected in dependence on the mass and speed. The mass of the carrier itself must be taken into account.

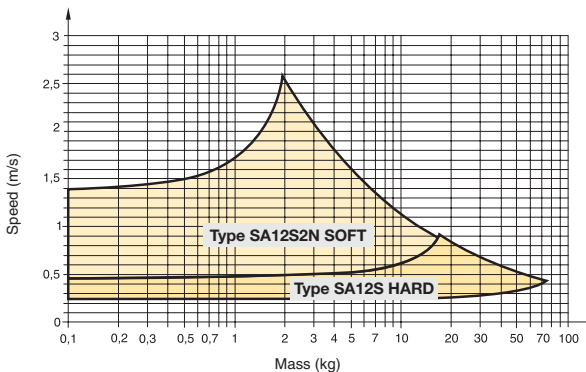
**Series OSP-KF16**

The values relate to an effective driving force of 78 N (6 bar)



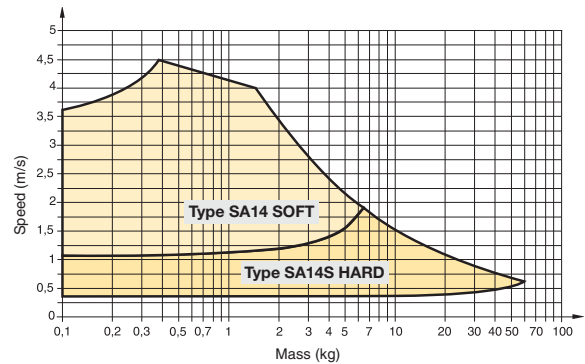
**Series OSP-KF25**

The values relate to an effective driving force of 250 N (6 bar)



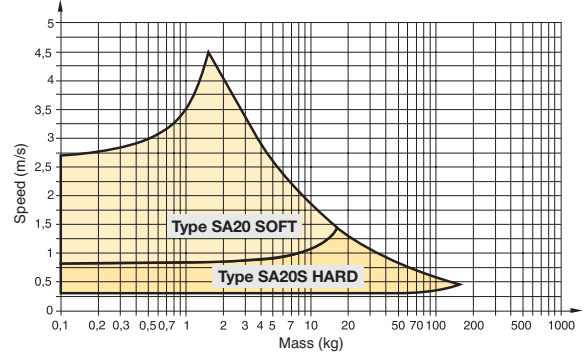
**Series OSP-KF32**

The values relate to an effective driving force of 420 N (6 bar)



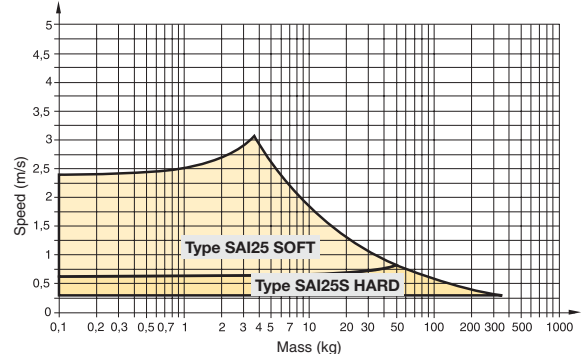
**Series OSP-KF40**

The values relate to an effective driving force of 640 N (6 bar)



**Series OSP-KF50**

The values relate to an effective driving force of 1000 N (6 bar)

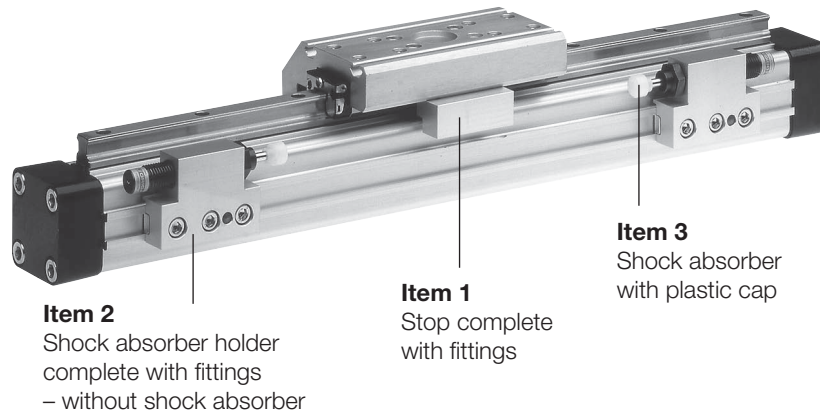


<b>G</b> Rodless Pneumatic Cylinders	OSP-P Series
	P1X Series
	P1Z Series
	GDL Series



For inventory, lead times, and kit lookup, visit [www.pdnplu.com](http://www.pdnplu.com)

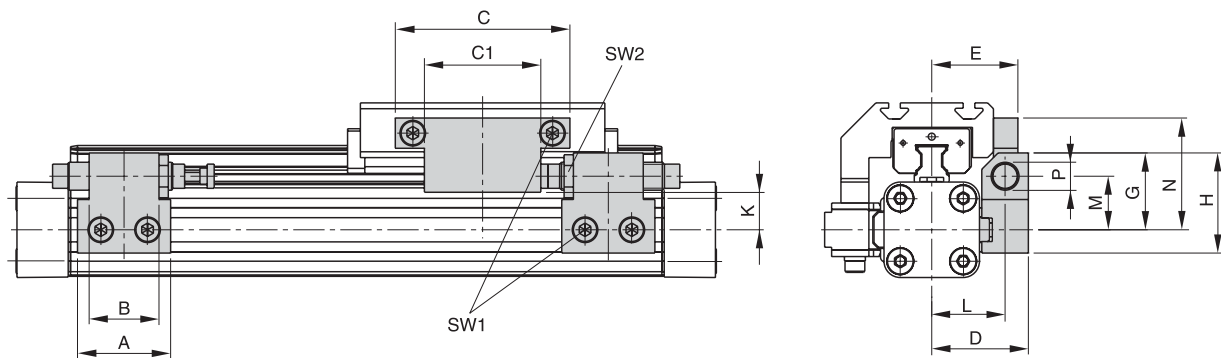
Ordering Information – Variable Stop Type VS16 to VS50



Item	Description	VS16		VS25		VS32		VS40		VS50	
		Type	Part number	Type	Part number	Type	Part number	Type	Part number	Type	Part number
1	Stop, complete	-	21186FIL	-	21187FIL	-	21188FIL	-	21189FIL	-	21290FIL
2	Shock absorber holder, complete	-	21201FIL	-	21202FIL	-	21203FIL	-	21204FIL	-	21205FIL
3 *	Shock absorber, standard	SA10SN	MC25M	SA12S2N	MC75M-1	SA14	MC150M-B	SA20	MC225M	SAI25	MC600M
	Shock absorber, version S	SA10S2N	MC25MH	SA12S	MC75M-2	SA14S	MC150MH-B	SA20S	MC225MH	SAI25S	MC600MH

\* Shock absorber with plastic cap

Dimension – Variable Stop Type VS16 to VS50



Dimension (mm) – Variable Stop Type VS16 to VS50

Series	Type	A	B	C	C1	D	E	G	H	K	L	M	N	P	SW1	SW2
OSP-KF16	VS16	30	14	50	25	33	29.7	28	38	16.2	25.5	20.5	40.5	M10 x 1	4	12.5
OSP-KF25	VS25	40	30	75	50	41.5	37	33	43	18	31.5	23	48	M12 x 1	5	16
OSP-KF32	VS32	60	40	50	-	45.5	41.5	35	45	19	35.5	25	37	M14 x 1.5	5	17
OSP-KF40	VS40	84	52	60	-	64	59	48	63	25.5	50	34	43	M20 x 1.5	5	24
OSP-KF50	VS50	84	-	60	-	75	69	55	70	26.9	57	38	58	M25 x 1.5	5	30



For inventory, lead time, and kit lookup, visit [www.pdnplu.com](http://www.pdnplu.com)

**End Cap Mounting – Type HP Ø 25 to 50mm (correspond to FESTO dimensions)**

For Linear-drive with Recirculating Ball Bearing Guide

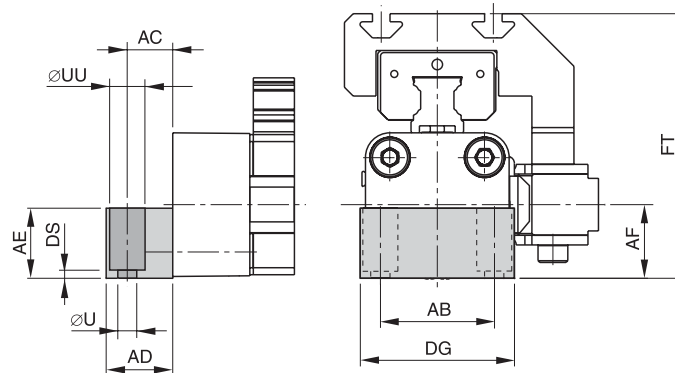
- Series OSP-P KF

On the end-face of each end cap there are four threaded holes for mounting the actuator.

**Material:**

- Anodized aluminum.

The mountings are supplied in pairs.



**Note:** Correspond to FESTO DGPL-KF, when the End Cap Mountings HP are mounted on the opposite side to the carriage (see drawing)

**Dimension (mm)**

Series	ØU	AB	AC	AD	AE	AF	DG	DS	FT	ØUU	Part number
HP25	5.5	32.5	13	19	20	21	44	2	75.5	10	21107FIL
HP32	6.6	38	17	24	24	27	52	3	87.5	11	21108FIL
HP40	6.6	45	17.5	24	24	35	68	2	104.5	11	21109FIL
HP50	9	65	25	35	35	48	86	6	138.5	15	21110FIL

**G**  
 Rodless Pneumatic Cylinders  
 OSP-P Series  
 P1X Series  
 P1Z Series  
 GDL Series



For inventory, lead times, and kit lookup, visit [www.pdnplu.com](http://www.pdnplu.com)

**Features**

**Heavy Duty Guide HD 25 to 50mm bore**

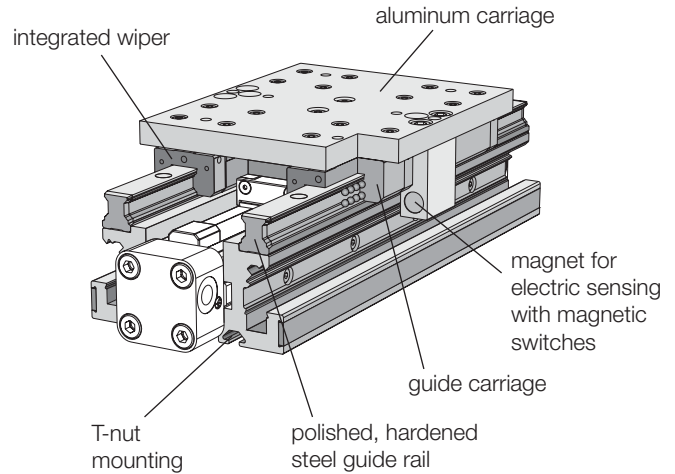
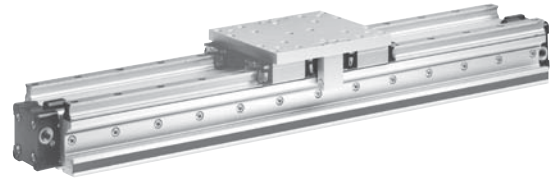
Series HD 25 to 50 for Linear-drive

- Series OSP-P



**Features**

- Guide system:
  - 4-row recirculating ball bearing guide
- Polished and hardened steel guide rail
- For highest loads in all directions
- Highest precision
- Integrated wiper system
- Integrated grease nipples
- Any lengths of stroke up to 3700 mm (longer strokes on request)
- Anodized aluminum guide carriage
  - dimensions compatible with OSP guide GUIDELINE
- Maximum speed v = 5 m/s



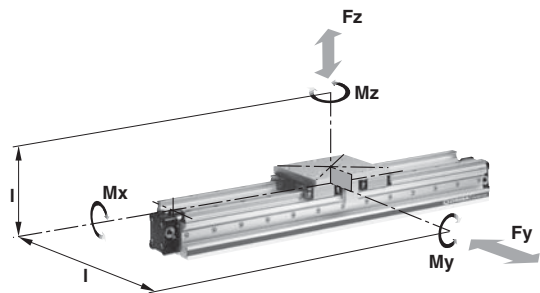
**Loads, Forces and Moments**

The table shows the maximum permissible loads. If multiple moments and forces act upon the cylinder simultaneously, the following equation applies:

$$\frac{M_x}{M_{xmax}} + \frac{M_y}{M_{ymax}} + \frac{M_z}{M_{zmax}} + \frac{F_y}{F_{ymax}} + \frac{F_z}{F_{zmax}} \leq 1$$

The sum of the loads should not exceed >1.

The table shows the maximum permissible values for light, shock-free operation which must not be exceeded even under dynamic conditions.



Series	for linear drive	Max. moments (Nm)			Max. loads (N)		Mass of the linear drive with guide (kg)		
		Mx	My	Mz	Fz	Fy	with 0mm stroke	increase per 100mm stroke	Mass * guide carriage (kg)
HD 25	OSP-P25	260	320	320	6000	6000	3.065	0.924	1.289
HD 32	OSP-P32	285	475	475	6000	6000	4.308	1.112	1.367
HD 40	OSP-P40	800	1100	1100	15000	15000	7.901	1.748	2.712
HD 50	OSP-P50	1100	1400	1400	18000	18000	11.648	2.180	3.551

\*Add the mass of the guide carriage to the mass to be cushioned.

**G**  
 Rodless Pneumatic Cylinders  
 OSP-P Series  
 P1X Series  
 P1Z Series  
 GDL Series

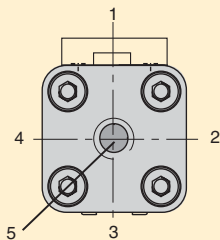


For inventory, lead time, and kit lookup, visit [www.pdnplu.com](http://www.pdnplu.com)

Ordering Information

Ordering information for OSP-P rodless KF pneumatic series

1-4	5-6	7	8	9	10	11	12-16	17	18	19	20	21	22	23	24	25								
OSPP	25	0	1	0	0	0	01100	0	0	0	0	0	0	1	0	0								
<b>Bore</b>		<b>Piston style</b>		<b>Lubrication</b>		<b>Stroke</b>		<b>Piston mounting</b>		<b>Cushions / Stops</b>		<b>Dovetail cover</b>		<b>Version</b>										
25 32 40 50		0 Standard 1 Tandem		0 Standard 1 Slow speed 4 Food 5 Clean room S Special		xxxxx		0 None		0 Standard 2 VS soft left 3 VS hard left 4 VS soft right 5 VS hard right 6 VS soft both sides 7 VS hard both sides S Special		0 Standard X Without cover rail S Special		0 Standard										
<b>Porting configurations</b>				<b>Seals</b>		<b>Fasteners</b>		<b>Guides / Brakes</b>				<b>Mounting</b>		<b>Switches</b> <sup>◊</sup>										
0 Standard (position #2) 1 End face (position #5) 2 Single end porting 3 Left stand (pos #2), Right end face (pos #5) 4 Right stand (pos #2), Left end face (pos #5) 6 Single end porting, end face A 3/2 way valve VOE, 24V = (25,32,40,50) B 3/2 way valve VOE, 220V~/110V = (25,32,40,50) C 3/2 way valve VOE, 48V = (25,32,40,50) E 3/2 way valve VOE, 110V = (25,32,40,50) S Special				0 Standard 1 Fluorocarbon		0 Standard 1 Stainless steel 3 Xylan coated & stainless steel fasteners S Special		D HD Heavy duty				0 None 0 None		0 None 1 NO Reed, P8S-GRFDX2 2 NC Reed, P8S-GEFRX1 3 PNP P8S-GPCHX+4041 4 NPN P8S-GNCHX+4041 X 21240 SFI 0,1mm Y 21241 SFI 1mm Z 4650 SFA S Special										
<b>Note:</b> Single end porting on 16mm bore, then end caps cannot be rotated.								<b>Additional carriages</b> **						<sup>◊</sup> Note: 2 switches will be supplied. For different quantity, please order as a separate line item.										
								0 None D Guide Carriage Heavy duty HD																
								<b>End Cap Port Position</b> <sup>Δ</sup>																
								0 l+r 0° = in front (pos #2) 1 l+r 90° = underneath (pos #3) 2 l+r 180° = at the back (pos #4) 3 l+r 270° = same face as outerband (pos #2,1) 4 l 90° = underneath; r 0° = in front (pos #3,2) 5 l 180° = at the back; r 0° = in front (pos #4,2) 6 l 270° = same face as outerband; r 0° = in front (pos #1,2) 7 l 0° = in front; r 90° = underneath (pos #2,3) 8 l 180° = at the back; r 90° = underneath (pos #4,3) 9 l 270° = same face as outerband; r 90° = underneath (pos #1,3) A l 0° = in front; r 180° = at the back (pos #2,4) B l 90° = underneath; r 180° = at the back (pos #3,4) C l 270° = same face as outerband; r 180° = at the back (pos #1,4) D l 0° = in front; r 270° = same face as outerband (pos #2,1) E l 90° = underneath; r 270° = same face as outerband (pos #3,1) F l 180° = at the back; r 270° = same face as outerband (pos #4,1) S Special																
								<b>Sensors</b>																
								See section L for sensors.																



Note: Position #2 is the standard location.

Δ Note: End cap port position  
L = Left end cap, R = right end cap

**G**  
 Rodless Pneumatic Cylinders  
 OSP-P Series  
 P1X Series  
 P1Z Series  
 GD L Series



For inventory, lead times, and kit lookup, visit [www.pdnplu.com](http://www.pdnplu.com)

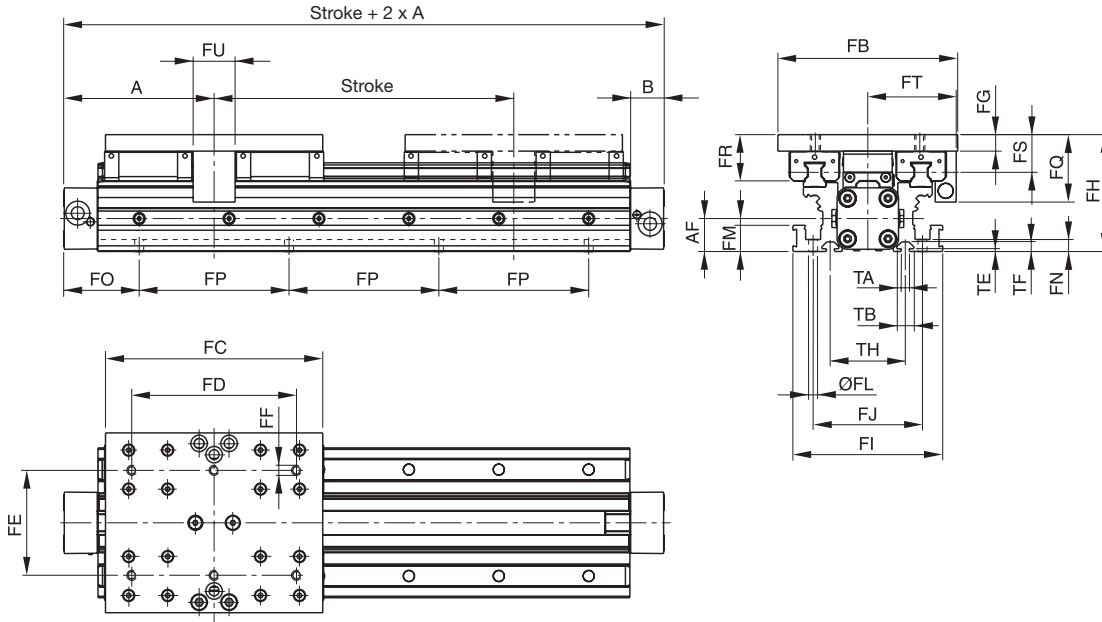
G72



**Series OSP-P HD 25 to 50mm**

**Note:** The HD heavy duty guide must be mounted on a flat surface for its entire length.

If T-grooves or T-bolts are used, the distance between them should not exceed 100 mm.



**Variable Stop  
 Type VS25 to VS50**

The variable stop provides simple stroke limitation and can be supplied mounted on the right or left, as required.

For further information see Variable Stop page G75.

For shock absorber selection see page G62.

**Incremental displacement  
 measuring system  
 ORIGA-Sensoflex**

Series SFI-plus can be supplied mounted on the right or left, as required.

For further information see page G95.

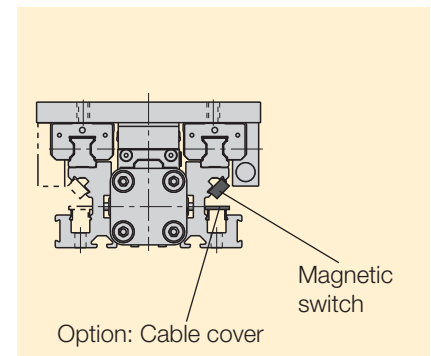
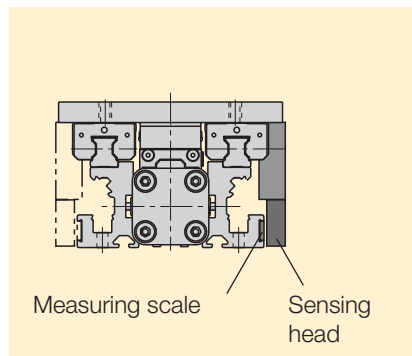
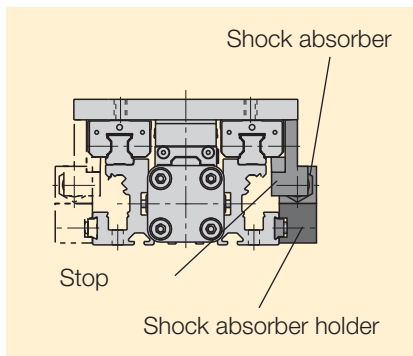
**Arrangement of magnetic  
 switches:**

Magnetic switches can be fitted anywhere on either side.

For further information see following data sheets:

Magnetic Switches see pages G87-G92.

Dovetail Cover see page G93



For inventory, lead time, and kit lookup, visit [www.pdnplu.com](http://www.pdnplu.com)

**Dimensional Data**

**Rodless Pneumatic Cylinders  
OSP-P Series, Heavy Duty Guide HD**

Series	A	B	AF	FB	FC	FD	FE	FF	FG	FH	FI	FJ	ØFL
HD25	100	22	22	120	145	110	70	M6	11	78	100	73	6
HD32	125	25.5	30	120	170	140	80	M6	11	86	112	85	6
HD40	150	28	38	160	180	140	110	M8	14	108	132	104	7.5
HD50	175	33	48	180	200	160	120	M8	14	118	150	118	7.5

Series	FM	FN	FP	FQ	FR	FS	FT	FU	TA	TB	TE	TF	TH
HD25	17.5	8	100	45	31	25	59	28	5.2	11.5	1.8	6.4	50
HD32	17.5	8	100	45	31	25	63	30	5.2	11.5	1.8	6.4	60
HD40	22	10	100	58	40	31.5	76	30	8.2	20	4.5	12.3	66
HD50	22	10	100	58	44	35.5	89	30	8.2	20	4.5	12.3	76

**Note:**

The dimension FO is derived from the last two digits of the stroke:

For a cylinder OSP-P25 the adjacent table indicates that for x = 25 mm:

FO = 62.5 mm

**Example:**

Stroke 15<sup>25</sup> mm



X	FO OSP-P				X	FO OSP-P				X	FO OSP-P			
	HD25	HD32	HD40	HD50		HD25	HD32	HD40	HD50		HD25	HD32	HD40	HD50
00	50.0	75.0	50.0	75.0	34	67.0	42.0	67.0	92.0	68	34.0	59.0	84.0	59.0
01	50.5	75.5	50.5	75.5	35	67.5	42.5	67.5	92.5	69	34.5	59.5	84.5	59.5
02	51.0	76.0	51.0	76.0	36	68.0	43.0	68.0	93.0	70	35.0	60.0	85.0	60.0
03	51.5	76.5	51.5	76.5	37	68.5	43.5	68.5	93.5	71	35.5	60.5	85.5	60.5
04	52.0	77.0	52.0	77.0	38	69.0	44.0	69.0	94.0	72	36.0	61.0	86.0	61.0
05	52.5	77.5	52.5	77.5	39	69.5	44.5	69.5	94.5	73	36.5	61.5	86.5	61.5
06	53.0	78.0	53.0	78.0	40	70.0	45.0	70.0	95.0	74	37.0	62.0	87.0	62.0
07	53.5	78.5	53.5	78.5	41	70.5	45.5	70.5	95.5	75	37.5	62.5	87.5	62.5
08	54.0	79.0	54.0	79.0	42	71.0	46.0	71.0	96.0	76	38.0	63.0	88.0	63.0
09	54.5	79.5	54.5	79.5	43	71.5	46.5	71.5	96.5	77	38.5	63.5	88.5	63.5
10	55.0	80.0	55.0	80.0	44	72.0	47.0	72.0	97.0	78	39.0	64.0	89.0	64.0
11	55.5	80.5	55.5	80.5	45	72.5	47.5	72.5	97.5	79	39.5	64.5	89.5	64.5
12	56.0	81.0	56.0	81.0	46	73.0	48.0	73.0	98.0	80	40.0	65.0	90.0	65.0
13	56.5	81.5	56.5	81.5	47	73.5	48.5	73.5	98.5	81	40.5	65.5	90.5	65.5
14	57.0	82.0	57.0	82.0	48	74.0	49.0	74.0	99.0	82	41.0	66.0	91.0	66.0
15	57.5	82.5	57.5	82.5	49	74.5	49.5	74.5	99.5	83	41.5	66.5	91.5	66.5
16	58.0	83.0	58.0	83.0	50	75.0	50.0	75.0	100.0	84	42.0	67.0	92.0	67.0
17	58.5	83.5	58.5	83.5	51	75.5	50.5	75.5	100.5	85	42.5	67.5	92.5	67.5
18	59.0	84.0	59.0	84.0	52	76.0	51.0	76.0	101.0	86	43.0	68.0	93.0	68.0
19	59.5	84.5	59.5	84.5	53	76.5	51.5	76.5	101.5	87	43.5	68.5	93.5	68.5
20	60.0	85.0	60.0	85.0	54	77.0	52.0	77.0	102.0	88	44.0	69.0	94.0	69.0
21	60.5	85.5	60.5	85.5	55	77.5	52.5	77.5	102.5	89	44.5	69.5	94.5	69.5
22	61.0	36.0	61.0	86.0	56	78.0	53.0	78.0	103.0	90	45.0	70.0	95.0	70.0
23	61.5	36.5	61.5	86.5	57	78.5	53.5	78.5	103.5	91	45.5	70.5	95.5	70.5
24	62.0	37.0	62.0	87.0	58	79.0	54.0	79.0	104.0	92	46.0	71.0	96.0	71.0
25	62.5	37.5	62.5	87.5	59	79.5	54.5	79.5	104.5	93	46.5	71.5	96.5	71.5
26	63.0	38.0	63.0	88.0	60	80.0	55.0	80.0	105.0	94	47.0	72.0	97.0	72.0
27	63.5	38.5	63.5	88.5	61	80.5	55.5	80.5	105.5	95	47.5	72.5	97.5	72.5
28	64.0	39.0	64.0	89.0	62	81.0	56.0	81.0	106.0	96	48.0	73.0	98.0	73.0
29	64.5	39.5	64.5	89.5	63	81.5	56.5	81.5	106.5	97	48.5	73.5	98.5	73.5
30	65.0	40.0	65.0	90.0	64	82.0	57.0	82.0	107.0	98	49.0	74.0	99.0	74.0
31	65.5	40.5	65.5	90.5	65	82.5	57.5	82.5	107.5	99	49.5	74.5	99.5	74.5
32	66.0	41.0	66.0	91.0	66	83.0	58.0	83.0	108.0					
33	66.5	41.5	66.5	91.5	67	83.5	58.5	83.5	108.5					

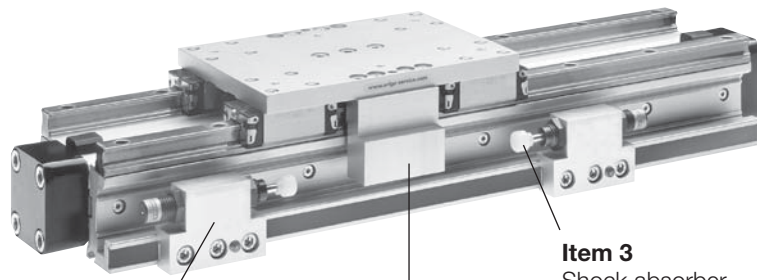
**G**  
 Rodless Pneumatic Cylinders  
 OSP-P Series  
 P1X Series  
 P1Z Series  
 GDL Series



For inventory, lead times, and kit lookup, visit [www.pdnplu.com](http://www.pdnplu.com)



**Ordering Information – Variable Stop Type VS25 to VS50**



**Item 2**  
Shock absorber holder  
complete with fittings  
– without shock absorber

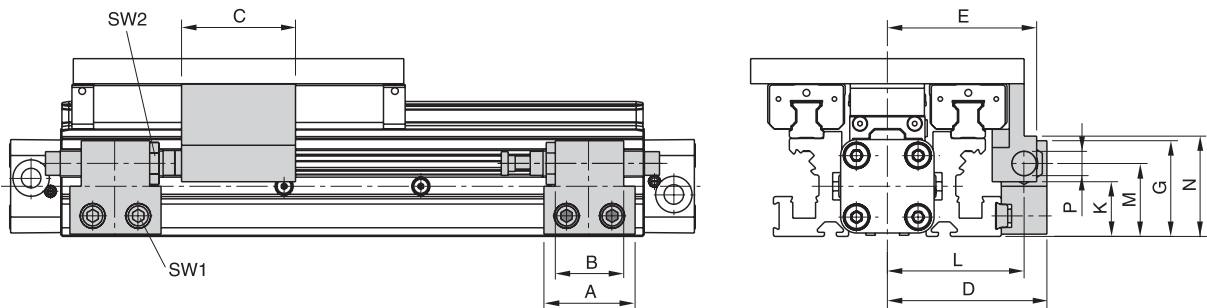
**Item 1**  
Stop complete  
with fittings

**Item 3**  
Shock absorber  
with plastic cap

Item	Description	Size VS25		Size VS32		Size VS40		Size VS50	
		Type	Part number	Type	Part number	Type	Part number	Type	Part number
1	Stop, complete	–	<b>21257FIL</b>	–	<b>21158FIL</b>	–	<b>21159FIL</b>	–	<b>21260FIL</b>
2	Shock absorber holder, complete	–	<b>21202FIL</b>	–	<b>21203FIL</b>	–	<b>21204FIL</b>	–	<b>21205FIL</b>
3 *	Shock absorber, standard	SA12	<b>MC75M-1</b>	SA14	<b>MC150M-B</b>	SA20	<b>MC225M</b>	SAI25	<b>MC600M</b>
	Shock absorber, version S	SA12S	<b>MC75M-2</b>	SA14S	<b>MC150MH-B</b>	SA20S	<b>MC225MH</b>	SAI25S	<b>MC600MH</b>

\* Shock absorber with plastic cap

**Dimension – Variable Stop Type VS16 to VS50**



Series	Type	A	B	C	D	E	G	K	L	M	N	P	SW1	SW2
OSP-HD25	VS25	40	30	50	70	65.5	42	26	60	32	42	M12 x 1	5	16
OSP-HD32	VS32	60	40	54	73	71	44	28	63	34	53	M14 x 1.5	5	17
OSP-HD40	VS40	84	52	55	96	92	59	35	82	45	61	M20 x 1.5	5	24
OSP-HD50	VS50	84	-	60	107	105	66	37	89	49	66	M25 x 1.5	5	30

**Shock Absorber Selection**

For shock absorber selection in dependence on mass and speed see page G68.



For inventory, lead time, and kit lookup, visit [www.pdnplu.com](http://www.pdnplu.com)

**Intermediate Stop Module – 25mm only**

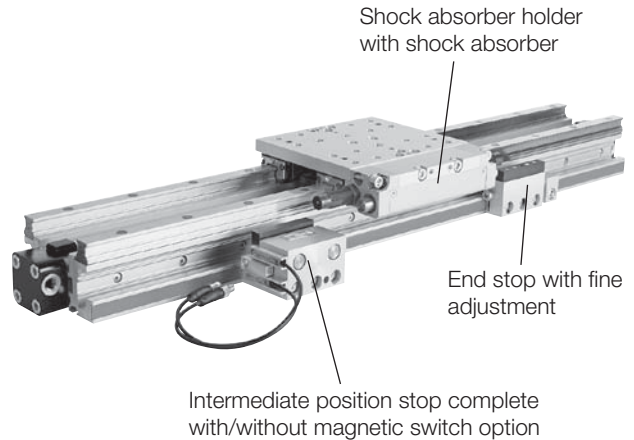
The intermediate stop module ZSM allows the guide carriage to stop at any desired intermediate positions with high accuracy. It can be retrofitted. Depending on the application, i.e. the number of intermediate stops, one or more intermediate position stops can be used.

The intermediate position stops can be retracted and extended without the need for the guide carriage to be moved back out of position.

Therefore the guide carriage can be made to stop at the defined intermediate positions in any order.

**ORIGA intermediate stop module ZSM:**

- Allows stopping at any intermediate positions
- Intermediate position stops can be located steplessly anywhere along the whole stroke length
- Movement to the next position without reverse stroke
- Compact unit
- Cost-effective positioning module without electrical or electronic components
- Option: end stop with fine adjustment



**Operating information**

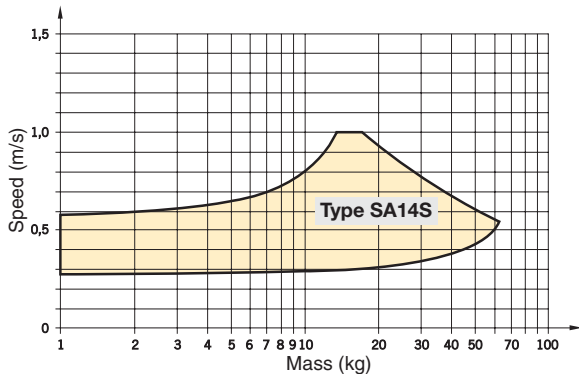
Operating pressure:	87 to 116 PSIG (4 to 8 bar)
Temperature range:	14°F to 158°F (-10°C to 70°C)
Intermediate position grid:	85mm

**G**  
 Rodless Pneumatic Cylinders  
 OSP-P Series  
 P1X Series  
 P1Z Series  
 GDL Series

**Shock Absorber**

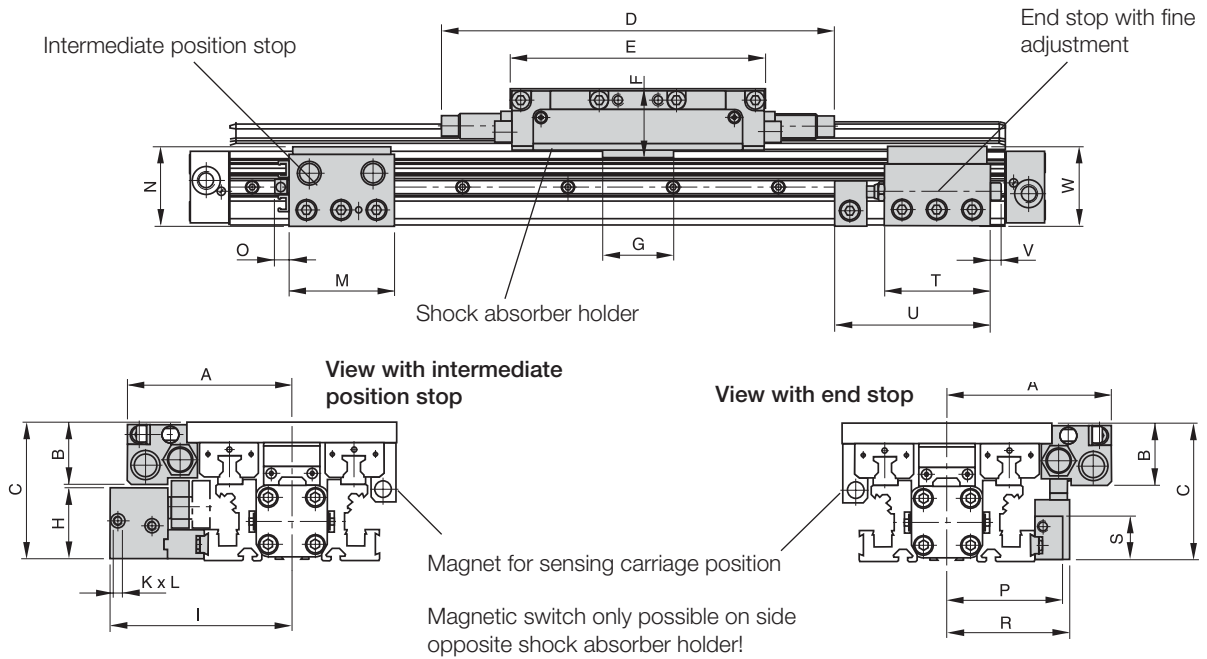
**Type SA14S**

The values relate to an effective driving force of 250 N (6 bar)



For inventory, lead times, and kit lookup, visit [www.pdnplu.com](http://www.pdnplu.com)

Intermediate Stop Module – Type ZSM..HD

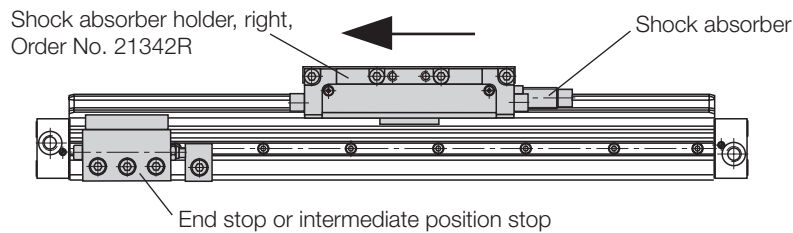


Dimension (mm)

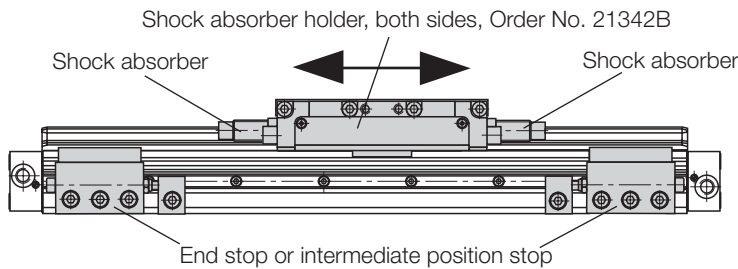
Series	A	B	C	D	E	F	G	H	I	K	L	M	N	O	P	R	S	T	U	V	W
ZSM25	94	35	78	224	145	39	40	41	104	M5	5	60	45	8	66	70	26	60	93	6	45

Shock Absorber Arrangement in Dependence on Direction of Movement

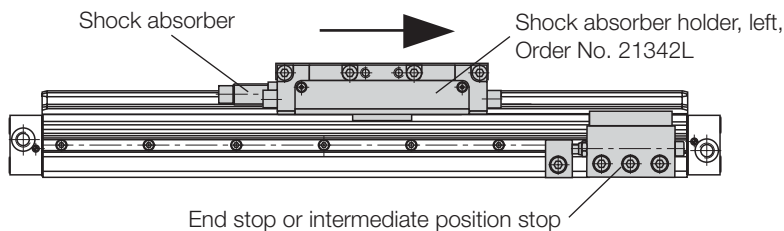
From right to left



In both directions



From left to right



Rodless Pneumatic Cylinders

OSP-P Series

P1X Series

P1Z Series

GDL Series



For inventory, lead time, and kit lookup, visit [www.pdnplu.com](http://www.pdnplu.com)

G77

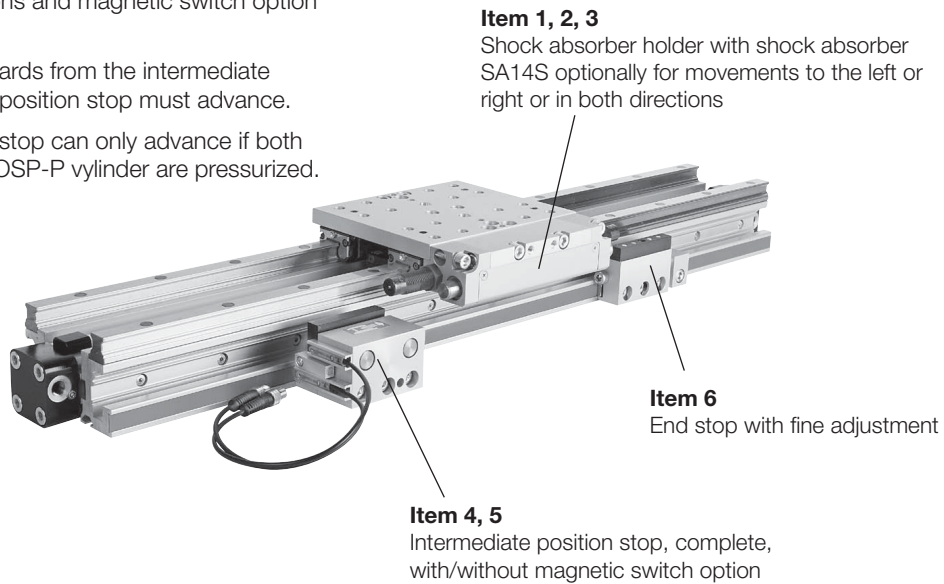
Parker Hannifin Corporation  
Pneumatic Division  
Richland, Michigan  
[www.parker.com/pneumatics](http://www.parker.com/pneumatics)

**Order Instructions – intermediate Stop Module Type ZSM..HD**

Illustration shows version with shock absorber holder for movement in both directions and magnetic switch option with T-slot switches.

**Note:** For movement onwards from the intermediate position, the intermediate position stop must advance.

The intermediate position stop can only advance if both cylinder chambers of the OSP-P cylinder are pressurized.



**Item 1, 2, 3**  
Shock absorber holder with shock absorber SA14S optionally for movements to the left or right or in both directions

**Item 6**  
End stop with fine adjustment

**Item 4, 5**  
Intermediate position stop, complete, with/without magnetic switch option

**Order instructions – intermediate stop module Type ZSM..HD 25mm Only**

For intermediate stop module	Item	Description	Part number
ZSM25HD	1*	Shock absorber holder with shock absorber SA14S, both sides	21342BFIL
ZSM25HD	2*	Shock absorber holder with shock absorber SA14S, left	21342LFIL
ZSM25HD	3*	Shock absorber holder with shock absorber SA14S, right	21342RFIL
ZSM25HD	4	Intermediate position stop complete, without magnetic switch option	21343FIL
ZSM25HD	5	Intermediate position stop complete, with magnetic switch option	21344FIL
ZSM25HD	6	End stop with fine adjustment	21346FIL

\* The shock absorbers are installed in the shock absorber holder and adjusted in our workshop.

**G**  
 Rodless Pneumatic Cylinders  
 OSP-P Series  
 P1X Series  
 P1Z Series  
 GDL Series



For inventory, lead times, and kit lookup, visit [www.pdnplu.com](http://www.pdnplu.com)

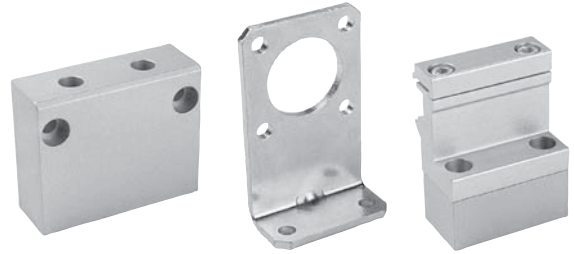
**Overview**

**Rodless Pneumatic Cylinders  
OSP-P Series, Linear Drive Accessories**



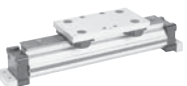

**Mountings for Linear Drives fitted with OSP-Guides**


For Linear-drive

- Series OSP-P



Type – OSP Guides

Mounting Type	Type	SLIDELINE PROLINE MULTIBRAKE						POWERSLIDE										
		16 †	25	32	40	50	63 †	80 †	16/ 25	25/ 25	25/ 35	25/ 44	32/ 35	32/ 44	40/ 44	40/ 60	50/ 60	50/ 76
 End cap mounting	Type A1	X							X									
	Type A2	O	O	O														
	Type A3									O	O		O					
 End cap mounting, reinforced	Type B1		X	X						X	X	X	X	X				
	Type B3								O									
	Type B4											O		O				
	Type B5																	
 End cap mounting	Type C1				X	X	X	X							X	X	X	X
	Type C2				O	O												
	Type C3						O	O							O		O	
	Type C4															O		O
Mid-Section support, small	Type D1	X	X	X	X	X	X	X	X	X	X	X	X	X	X	X	X	X
 Mid-Section support, wide	Type E1	X	X	X	X	X	X	X	X	X	X	X	X	X	X	X	X	X
	Type E2	O	O	O	O	O												
	Type E3						O	O	O	O	O		O		O		O	
	Type E4											O		O		O		O
	Type E5																	

- X** = carriage mounted in top (12 o'clock position)
- O** = carriage mounted in lateral (3 or 9 o'clock position)
-  = available components
- †** = not available for all sizes

**G**  
 Rodless Pneumatic Cylinders  
 OSP-P Series  
 P1X Series  
 P1Z Series  
 GDL Series



For inventory, lead time, and kit lookup, visit [www.pdnplu.com](http://www.pdnplu.com)

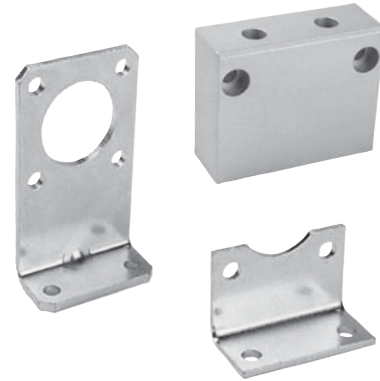
**End Cap Mountings**

Four internal screw threads are located in the end faces of all OSP actuators for mounting the drive unit. End cap mountings may be secured across any two adjacent screws.

**Material:**

- Series OSP-16, 25, 32: Galvanized steel
- Series OSP-40, 50, 63, 80: Anodized aluminum

The mountings are supplied in pairs.



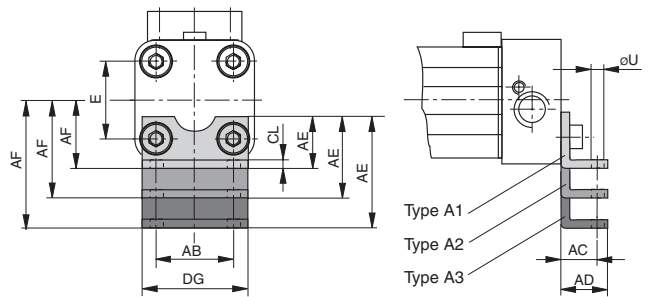
**Dimension (mm)**

**AE and AF (Dependent on the mounting type)**

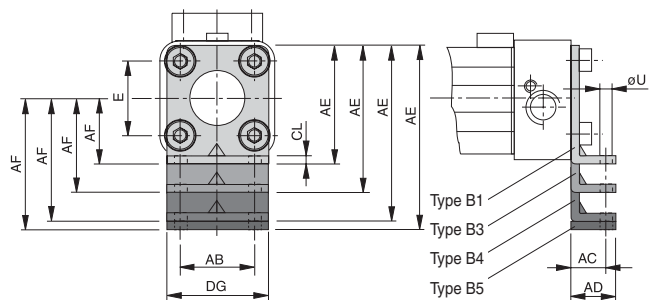
Mount. type	Dimensions AE for size							AF for size						
	16	25	32	40	50	63	80	16	25	32	40	50	63	80
A1	12.5	18	20	-	-	-	-	15	22	30	-	-	-	-
A2	27.5	33	34	-	-	-	-	30	37	44	-	-	-	-
A3	-	45	42	-	-	-	-	49	52	-	-	-	-	-
B1	-	42	55	-	-	-	-	22	30	-	-	-	-	-
B3	55	-	-	-	-	-	-	42	-	-	-	-	-	-
B4	-	80	85	-	-	-	-	60	60	-	-	-	-	-
B5	-	-	90	-	-	-	-	65	-	-	-	-	-	-
C1	-	-	-	24	30	40	50	-	-	-	38	48	57	72
C2	-	-	-	37	39	-	-	-	-	-	51	57	-	-
C3	-	-	-	46	54	76	88	-	-	-	60	72	93	110
C4	-	-	-	56	77	-	-	-	-	-	70	95	-	-

Series	E	øU	AB	AC	AD	CL	DG
OSP-P16	18	3.6	18	10	14	1.6	26
OSP-P25	27	5.8	27	16	22	2.5	39
OSP-P32	36	6.6	36	18	26	3	50
OSP-P40	54	9	30	12.5	24	-	68
OSP-P50	70	9	40	12.5	24	-	86
OSP-P63	78	11	48	15	30	-	104
OSP-P80	96	14	60	17.5	35	-	130

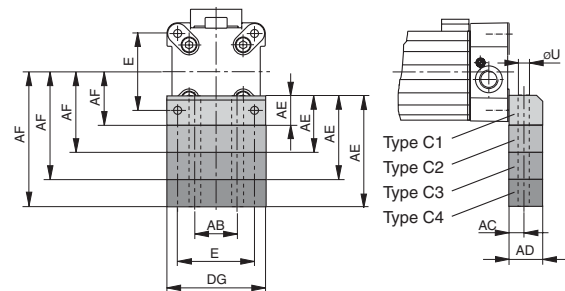
**Series OSP-P16, 25, 32: Type A**



**Series OSP-P16, 25, 32: Type B**



**Series OSP-P40, 50, 63, 80: Type C**



**G**  
 Rodless Pneumatic Cylinders  
 OSP-P Series  
 P1X Series  
 P1Z Series  
 GDL Series



For inventory, lead times, and kit lookup, visit [www.pdnplu.com](http://www.pdnplu.com)

**End Cap Mountings – Type B Ø 16 to 32mm**

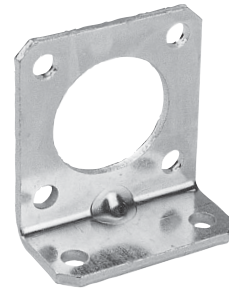
For Linear-drive with Recirculating Ball Bearing Guide

- Series OSP-P STL
- Series OSP-P KF

**Material:**

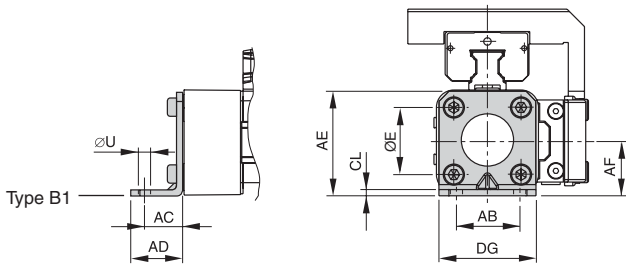
- Galvanized steel
- Anodized aluminum

The mountings are supplied in pairs.  
Drawing shows: Mounting with Guide Type STL



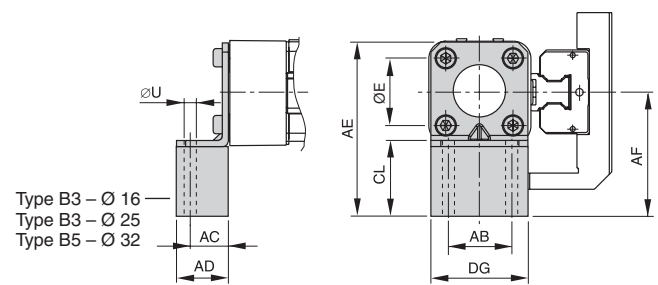
**Type B1: 16, 25, 32mm**  
Series OSP-P STL and KF

Installation: Top carrier  
Side piston



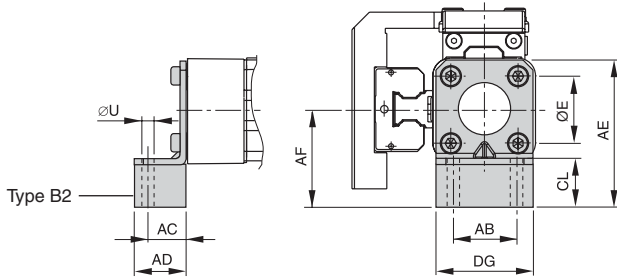
**Type B3: 16, 25mm**  
**Type B5: 32mm**  
Series OSP-P STL and KF

Installation: Side carrier  
Piston below



**Type B2: 16, 25, 32mm**  
Series OSP-P STL and KF

Installation: Side carrier  
Top piston



**Dimension (mm), Type B**

Series Type	Mounting	E	ØU	AB	AC	AD	AE	AF	CL	DG	Part number (pair)
OSP-P STL16	B1	18	3.6	18	10	14	28	15	2	26	21135FIL
OSP-P KF16	B2	18	3.6	18	10	14	43	30	17	26	21136FIL
	B3	18	3.6	18	10	14	55	42	29	26	21137FIL
OSP-P STL25	B1	27	5.8	27	16	22	42	22	2.5	39	20311FIL
OSP-P KF25	B2	27	5.8	27	16	22	57	37	17.5	39	21138FIL
	B3	27	5.8	27	16	22	69	49	29.5	39	21139FIL
OSP-P STL32	B1	36	6.6	36	18	26	55	30	3	50	20313FIL
OSP-P KF32	B2	36	6.6	36	18	26	69	44	17	50	21140FIL
	B5	36	6.6	36	18	26	90	65	9	50	21141FIL



For inventory, lead time, and kit lookup, visit [www.pdnplu.com](http://www.pdnplu.com)

**Mid-Section Support – Type D1ST Ø 16 to 50mm**

For Linear-drive with Recirculating Ball Bearing Guide

- Series OSP-P STL
- Series OSP-P KF

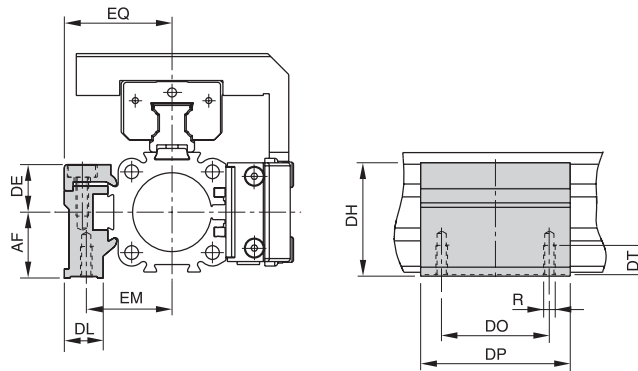
**Note:** on Types D1ST

The mid-section support can also be mounted on the underside of the actuator, in which case its distance from the center of the actuator is different.



Drawing shows: Mounting with Guide Type STL  
Mountings from below with 2 screws

**Type D1ST: 16 to 50mm  
Series OSP-P STL and KF**



**Dimension (mm), Type D1ST**

Series	OSP-P ...	Mounting	R	AF	DE	DH	DL	DO	DP	DT	EM	EQ	Part number
	STL/KF16	D1ST	M3	15	14.2	29.2	14.6	18	30	6.5	20	27	21125FIL
	STL/KF25	D1ST	M5	22	16	38	13	36	50	10	28.5	36	21126FIL
	STL/KF32	D1ST	M5	30	16	46	13	36	60	10	35.5	43	21127FIL
	STL/KF40	D1ST	M6	38	23	61	19	45	60	11	38	48	21128FIL
	STL/KF50	D1ST	M6	48	23	71	19	45	60	11	45	57	21129FIL

Order example: Type D1ST16 **Part number: 21125FIL**

**G**  
 Rodless Pneumatic Cylinders  
 OSP-P Series  
 P1X Series  
 P1Z Series  
 GDL Series



For inventory, lead times, and kit lookup, visit [www.pdnplu.com](http://www.pdnplu.com)



**Mid-Section Support**

**Information regarding type E1 and D1:**

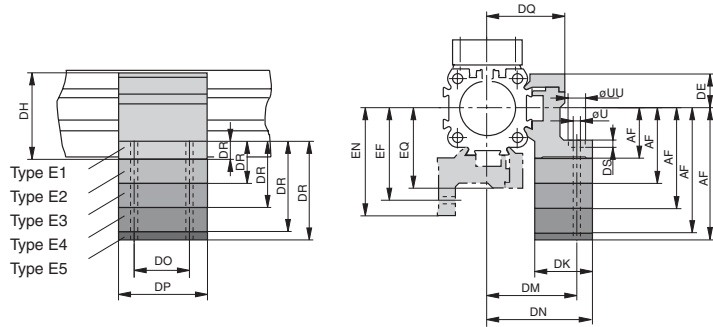
Mounting of the Mid-Section supports is also possible on the lower side of the drive. In this case, please note the new center line dimensions.

Stainless steel version on request.



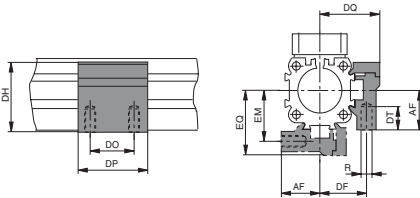
**Series OSP-P16 to 80: Type E**

(Mounting from above / below using a cap screw)



**Series OSP-P16 to 80: Type D1**

(Mounting from below with thread screw)



**Dimension (mm) - AF and DR (Dependent on the mounting type)**

Mount. type	DR for size								AF for size							
	16	25	32	40	50	63	80	16	25	32	40	50	63	80		
D1	-	-	-	-	-	-	-	15	22	30	38	48	57	72		
E1	6	8	10	10	10	12	15	15	22	30	38	48	57	72		
E2	21	23	24	23	19	-	-	30	37	44	51	57	-	-		
E3	33	35	32	32	34	48	53	42	49	52	60	72	93	110		
E4	-	46	40	42	57	-	-	60	60	70	95	-	-	-		
E5	-	-	45	-	-	-	-	-	65	-	-	-	-	-		

**Dimension Table (mm)**

Series	R	U	UU	DE	DF	DH	DK	DM	DN	DO	DP	DQ	DS	DT	EF	EM	EN	EQ
OSP-P16	M3	3.4	6	14.2	20	29.2	24	32	36.4	18	30	27	3.4	6.5	32	20	36.4	27
OSP-P25	M5	5.5	10	16	27	38	26	40	47.5	36	50	34.5	5.7	10	41.5	28.5	49	36
OSP-P32	M5	5.5	10	16	33	46	27	46	54.5	36	50	40.5	5.7	10	48.5	35.5	57	43
OSP-P40	M6	7	-	23	35	61	34	53	60	45	60	45	-	11	56	38	63	48
OSP-P50	M6	7	-	23	40	71	34	59	67	45	60	52	-	11	64	45	72	57
OSP-P63	M8	9	-	34	47.5	91	44	73	83	45	65	63	-	16	79	53.5	89	69
OSP-P80	M10	11	-	39.5	60	111.5	63	97	112	55	80	81	-	25	103	66	118	87

**Ordering information for mountings – Type A, Type B, Type C, Type D, Type E**

Mounting type (versions)	Part number							
	16	25	32	40	50	63	80	
A1 †	20408FIL	2010	3010	-	-	-	-	
A2 †	20464FIL	2040	3040FIL	-	-	-	-	
A3 †	-	2060FIL	3060FIL	-	-	-	-	
B1 †	-	20311FIL	20313FIL	-	-	-	-	
B3 †	20465FIL	-	-	-	-	-	-	
B4 †	-	20312FIL	20314FIL	-	-	-	-	
B5 †	-	-	20976FIL	-	-	-	-	
C1 †	-	-	-	4010FIL	5010FIL	6010FIL	8010FIL	
C2 †	-	-	-	20338FIL	20349FIL	-	-	
C3 †	-	-	-	20339FIL	20350FIL	20821FIL	20822FIL	
C4 †	-	-	-	20340FIL	20351FIL	-	-	
D1	20434FIL	20008FIL	20157FIL	20027FIL	20162FIL	20451FIL	20480FIL	
E1	20435FIL	20009FIL	20158FIL	20028FIL	20163FIL	20452FIL	20482FIL	
E2	20436FIL	20352FIL	20355FIL	20358FIL	20361FIL	-	-	
E3	20437FIL	20353FIL	20356FIL	20359FIL	20362FIL	20453FIL	20819FIL	
E4	-	20354FIL	20357FIL	20360FIL	20363FIL	-	-	
E5	-	-	20977FIL	-	-	-	-	

† Pair



For inventory, lead time, and kit lookup, visit [www.pdnplu.com](http://www.pdnplu.com)

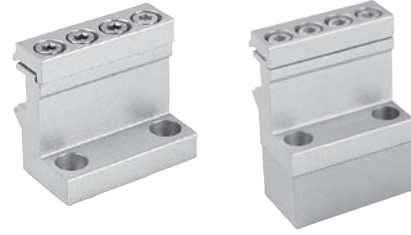
**G**  
 Rodless Pneumatic Cylinders  
 OSP-P Series  
 P1X Series  
 P1Z Series  
 GDL Series

**Mid-Section Support – Type E1ST to E5ST Ø 16 to 50mm**

For Linear-drive with Recirculating Ball Bearing Guide

- Series OSP-P STL
- Series OSP-P KF

Drawing shows: Mounting with Guide Type STL  
Mountings from below with 2 screws

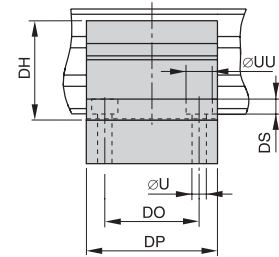
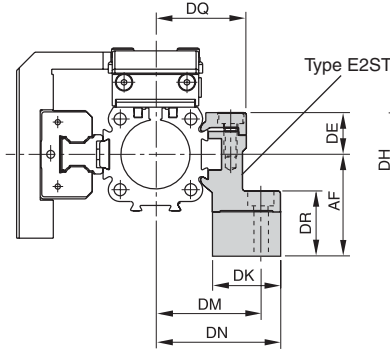
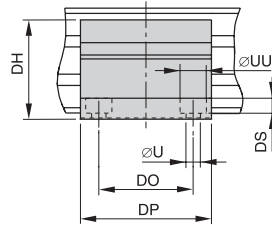
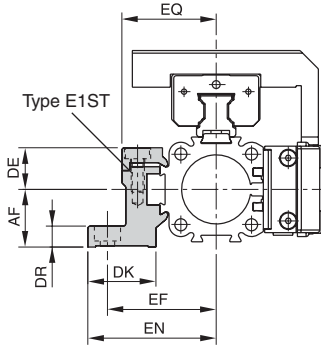


**Type E1ST: 16 to 50mm**  
Series OSP-P STL and KF

Installation: **Top carrier**  
**Side position**

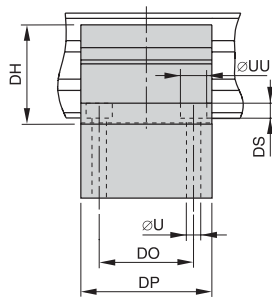
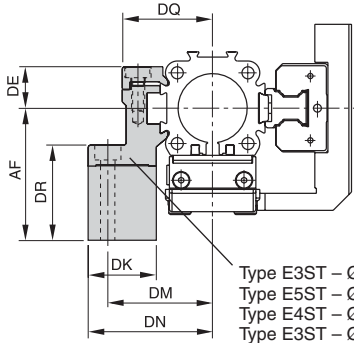
**Type E2ST: 16 to 50mm**  
Series OSP-P STL and KF

Installation: **Side carrier**  
**Top piston**



**Type E3ST, E4ST, E5ST: 25 to 50mm**  
Series OSP-P STL and KF

Installation: **Side carrier**  
**Piston below**



Type E3ST – Ø25  
Type E5ST – Ø32  
Type E4ST – Ø40  
Type E3ST – Ø50

**Dimension (mm), Type E1ST to E5ST**

Series	OSP-P ...	Mounting	ØU	ØUU	AF	DE	DH	DK	DM	DN	DO	DP	DR	DQ	DS	EF	EN	EQ	Part number
OSP-P Series	STL/KF16	E1ST	3.4	6	15	14.2	29.2	24	32	36.4	18	30	6	27	3.4	32	36.4	27	21130FIL
	STL/KF16	E2ST	3.4	6	30	14.2	29.2	24	32	36.4	18	30	21	27	3.4	32	36.4	27	21142FIL
P1X Series	STL/KF25	E1ST	5.5	10	22	16	38	26	40	47.5	36	50	8	34.5	5.7	41.5	49	36	21131FIL
	STL/KF25	E2ST	5.5	10	37	16	38	26	40	47.5	36	50	23	34.5	5.7	41.5	49	36	21143FIL
	STL/KF25	E3ST	5.5	10	49	16	38	26	40	47.5	36	50	35	34.5	5.7	41.5	49	36	21148FIL
P1Z Series	STL/KF32	E1ST	5.5	10	30	16	46	27	46	54.5	36	60	10	40.5	5.7	48.5	57	43	21132FIL
	STL/KF32	E2ST	5.5	10	44	16	46	27	46	54.5	36	60	24	40.5	5.7	48.5	57	43	21144FIL
	STL/KF32	E5ST	5.5	10	65	16	46	27	46	54.5	36	60	45	40.5	5.7	48.5	57	43	21151FIL
GDL Series	STL/KF40	E1ST	7	-	38	23	61	34	53	60	45	60	10	45	-	56	63	48	21133FIL
	STL/KF40	E2ST	7	-	51	23	61	34	53	60	45	60	23	45	-	56	63	48	21145FIL
	STL/KF40	E4ST	7	-	70	23	61	34	53	60	45	60	42	45	-	56	63	48	21150FIL
GDL Series	STL/KF50	E1ST	7	-	48	23	71	34	59	67	45	60	10	52	-	64	72	57	21134FIL
	STL/KF50	E2ST	7	-	57	23	71	34	59	67	45	60	19	52	-	64	72	57	21146FIL
	STL/KF50	E3ST	7	-	72	23	71	34	59	67	45	60	34	52	-	64	72	57	21149FIL

Order example: Type E1ST16 Part number: 21130FIL



For inventory, lead times, and kit lookup, visit [www.pdnplu.com](http://www.pdnplu.com)

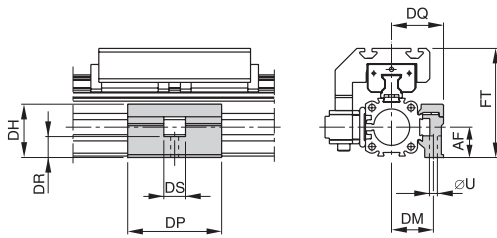
**Mid-Section Support – Type MUP Ø 25 to 50mm (correspond to FESTO dimensions)**

For Linear-drive with Recirculating Ball Bearing Guide

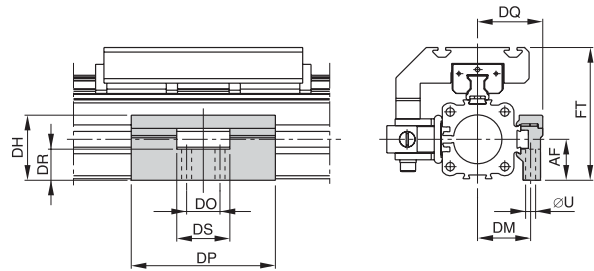
- Series OSP-P KF

**Note:** Correspond to FESTO DGPL-KF, when the Mid-Section Support MUP are mounted on the 90° side to the carriage (see drawings).

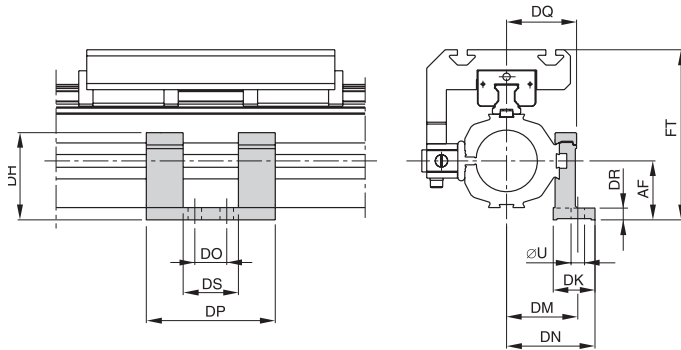
**Series OSP-P KF25: Type MUP**  
(Mounting over through holes)



**Series OSP-P KF32 to KF40: Type MUP**  
(Mounting over through holes)



**Series OSP-P KF50: Type MUP**  
(Mounting over through holes)



**Dimension (mm)**

Series	ØU	AF	DH	DK	DM	DN	DO	DP	DQ	DR	DS	FT	Part number
MUP25	5.5	21	36.9	–	29	–	–	65	36	14.5	15	75.5	21119FIL
MUP32	6.6	27	42.9	–	35	–	22	95	43	20.5	35	87.5	21120FIL
MUP40	6.6	35	58	–	40	–	22	95	48	28.5	35	104.5	21121FIL
MUP50	11	48	71	34	58	72	26	105	57	10	45	138.5	21122FIL



Rodless Pneumatic Cylinders

OSP-P Series

P1X Series

P1Z Series

GDL Series



For inventory, lead time, and kit lookup, visit [www.pdnplu.com](http://www.pdnplu.com)

G85

**Parker Hannifin Corporation**  
Pneumatic Division  
Richland, Michigan  
[www.parker.com/pneumatics](http://www.parker.com/pneumatics)

**End Cap Mountings – Type C Ø 40 to 50mm**

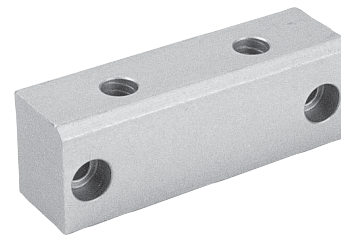
For Linear-drive with Recirculating Ball Bearing Guide

- Series OSP-P STL
- Series OSP-P KF

**Material:**

- Anodized aluminum

The mountings are supplied in pairs.  
Drawing shows: Mounting with Guide Type STL

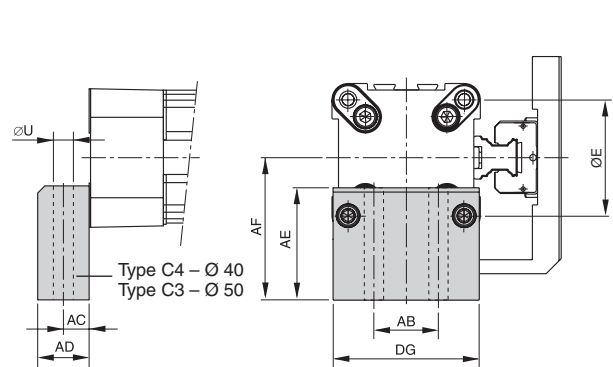
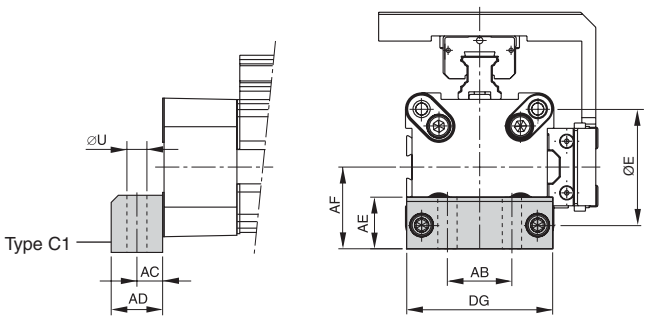


**Type C1: 40, 50mm**  
Series OSP-P STL and KF

Installation Top carrier  
Side piston

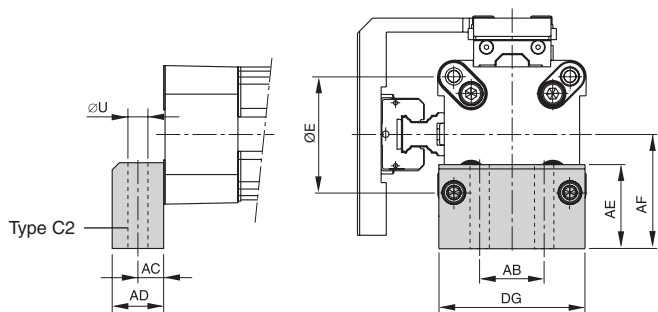
**Type C4: 40mm**  
**Type C3: 50mm**  
Series OSP-P STL and KF

Installation: Side carrier  
Piston below



**Type C2: 40, 50mm**  
Series OSP-P STL and KF

Installation: Side carrier  
Top piston



**Dimension (mm), Type C**

Series Type	Mounting	E	ØU	AB	AC	AD	AE	AF	DG	Part number (pair)
OSP-P STL40	C1	54	9	30	12.5	24	24	38	68	4010FIL
OSP-P KF40	C2	54	9	30	12.5	24	37	51	68	20338FIL
	C4	54	9	30	12.5	24	56	70	68	20340FIL
OSP-P STL50	C1	70	9	40	12.5	24	30	48	86	5010FIL
OSP-P KF50	C2	70	9	40	12.5	24	39	57	86	20349FIL
	C3	70	9	40	12.5	24	54	72	86	20350FIL

**G**  
 Rodless Pneumatic  
 Cylinders  
 OSP-P  
 Series  
 P1X  
 Series  
 P1Z  
 Series  
 GDL  
 Series



For inventory, lead times, and kit lookup, visit [www.pdnplu.com](http://www.pdnplu.com)

G86

**Parker Hannifin Corporation**  
Pneumatic Division  
Richland, Michigan  
[www.parker.com/pneumatics](http://www.parker.com/pneumatics)

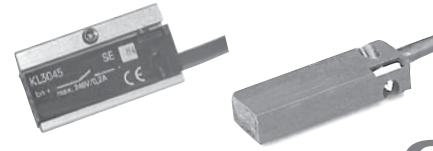
**Magnetic Switches, Ø10 to 80mm**

- Series RS
- Series ES

For electrical sensing of the carrier position, e.g. at the end positions, magnetic switches may be fitted.

Position sensing is contactless and is based on magnets fitted as standard to the carrier. A yellow LED indicates operating status.

The universal magnetic switches are suitable for all PARKER-ORIGA OSP-Actuators and aluminum profile rod type cylinders.



**OSP**  
ORIGA  
SYSTEM  
PLUS

**Piston, speed and switching distance affect signal duration and should be considered in conjunction with the minimum reaction time of ancillary control equipment.**

$$\text{Min. reaction time} = \frac{\text{Switching distance}}{\text{Piston speed}}$$

**Electrical Characteristics**

	Type RS	Type ES
Switching output	Reed	PNP, NPN
Operating voltage	10-240 VAC/DC (NO) 10-150 VAC/DC (NC)	10-30 VDC
Residual voltage	< 3 V	< 3 V
Connection	Two wire	Three wire
Output function	normally open normally closed	normally open
Permanent current	200 mA	200 mA
Max. switching capacity	10 VA (W)	—
Power consumption without load	—	< 20 mA
Function indicator	LED, yellow	LED, yellow
Typical switching time	On: < 2 ms	On: < 2 ms
Switch-off delay	—	ca. 25 ms
Pole reversal does not work	LED	—
Pole reversal protection	—	Built in
Short-circuit protection	—	Built in
Switchable capacity load	µF	µF 0.1 at 100 Ω, 24 VDC
Switching point accuracy	± 0.2mm	± 0.2mm
Switching distance	ca. 15mm	ca. 15mm
Hysteresis for OSP	ca. 8mm	ca. 3mm
Lifetime	3 x 10 <sup>6</sup> , up to 6 x 10 <sup>6</sup> cycles	Theoretically unlimited

**Mechanical Characteristics**

	Type RS	Type ES
Housing	Makrolon, smoke color	
Cable cross section	2 x 0.14 mm <sup>2</sup>	3 x 0.14 mm <sup>2</sup>
Cable type *	PVC	PUR, black
Bending radius	fixed ≥ 20mm moving ≥ 70mm	
Weight (Mass)	0.012 kg	
Degree of protection	IP67 to DIN EN 60529	
Ambient temperature range * †	-25°C to 80°C	
Shock resistance	100 m/s <sup>2</sup> (contact switches)	500 m/s <sup>2</sup>

\* Other versions on request

† For the magnetic switch temperature range, please take into account the surface temperature and the self-heating properties of the linear drive. On request other temperature ranges available.

**G****Rodless Pneumatic  
Cylinders****OSP-P  
Series****P1X  
Series****P1Z  
Series****GDL  
Series**

**Magnetic Switches RS and ES**

**Electrical Service Life Protective Measures**

Magnetic switches are sensitive to excessive currents and inductions. With high switching frequencies and inductive loads such as relays, solenoid valves or lifting magnets, service life will be greatly reduced.

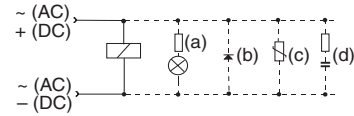
With **resistive and capacitive loads** with high switch-on current, such as light bulbs, a protective resistor should be fitted. This also applies to long cable lengths and voltages over 100 V.

In the switching of inductive loads such as relays, solenoid valves and lifting magnets, voltage peaks (transients) are generated which must be suppressed by protective diodes, RC loops or varistors.

**Connection Examples**

Load with protective circuits

- (a) Protective resistor for light bulb
- (b) Freewheel diode on inductively
- (c) Varistor on inductively
- (d) RC element on inductively



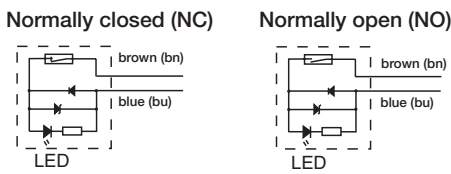
For the type ES, external protective circuits are not normally needed.

**Type RS**

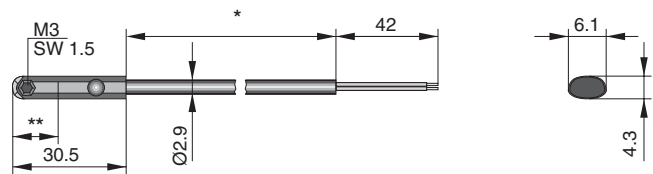
In the type RS contact is made by a mechanical reed switch encapsulated in glass.

Direct connection with 2-pole cable, 5 m long, open ended (Type RS-K).

**Electrical Connection:**



**Dimensions (mm) – Type RS-K**



\* Length with possible minus tolerance, see chart below

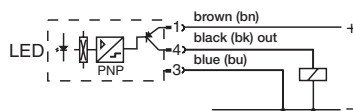
**Type ES**

In the type ES contact is made by an electronic switch – without bounce or wear and protected from pole reversal. The output is short circuit proof and insensitive to shocks and vibrations. Connection is by 3-pole connector for easy disconnection. Fitted with connection cable 100 mm long with connector.

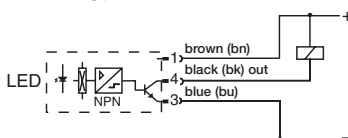
A 5 m cable with connector and open end can be ordered separately, or use the Order No. for the complete Type ES with 5 m cable.

**Electrical Connection:**

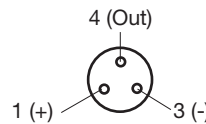
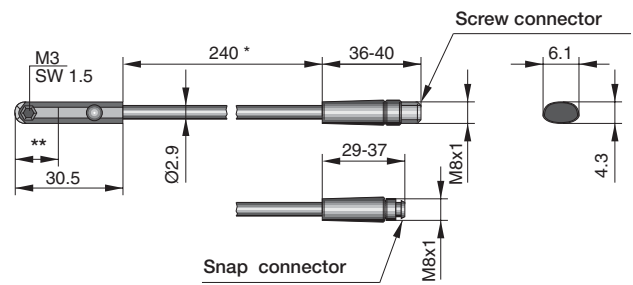
Standard Version: Type PNP



Optional Version: Type NPN



**Dimensions (mm) – Type ES-S**



PIN assignment (view of pins) according to DIN EN 50044

\* Length with possible minus tolerance, see chart below

**Length of connection cable with length tolerance**

Magnetic switch Part number	Nominal cable length	Length tolerance
P8S-GRFDX2	5000mm	- 50mm
P8S-GEFRX1	5000mm	- 50mm
P8S-GPCHX	100mm	- 20mm
P8S-GNCHX	145mm	± 5mm

**G**  
 Rodless Pneumatic Cylinders  
 OSP-P Series  
 P1X Series  
 P1Z Series  
 GDL Series

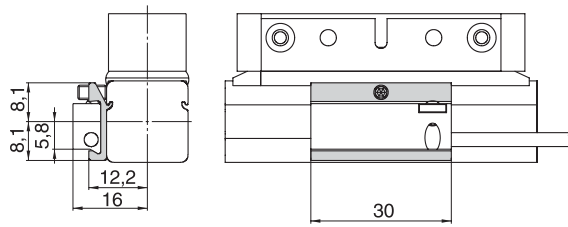


For inventory, lead times, and kit lookup, visit [www.pdnplu.com](http://www.pdnplu.com)

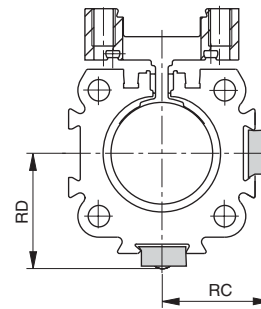
G88

**Parker Hannifin Corporation**  
 Pneumatic Division  
 Richland, Michigan  
[www.parker.com/pneumatics](http://www.parker.com/pneumatics)

**Dimensions Series OSP-P10**



**Dimensions Series OSP-P16 to 80**



Note:

Sensors can not be mounted directly opposite of the carrier

**Dimensions (mm) and Order Information**

Series	Dimensions		Part number						
	RC	RD	RS closer Normally open	RS opener Normally closed	ES		ES compl. with 5 m cable		Adapter only for OSP-P10
			Type:	Type:	PNP	NPN	PNP	NPN	
OSP-P10	-	-	RS-K	RS-K	ES-S	ES-S	ES-S	ES-S	
OSP-P16	20	20.5	P8S-GRFDX2	P8S-GEFRX1	P8S-GPCHX	P8S-GNCHX	P8S-GRFDX2 + 4041	P8S-GNCHX + 4041	please order separately
OSP-P25	25	27							
OSP-P32	31	34							
OSP-P40	36	39							
OSP-P50	43	48							
OSP-P63	53	59							
OSP-P80	66	72							
Cable 5 m with connector and with open end for magnetic switches Type ES-S					4041				

**G**

Rodless Pneumatic Cylinders

OSP-P Series

P1X Series

P1Z Series

GDL Series



For inventory, lead time, and kit lookup, visit [www.pdnplu.com](http://www.pdnplu.com)

G89

**Parker Hannifin Corporation**  
Pneumatic Division  
Richland, Michigan  
[www.parker.com/pneumatics](http://www.parker.com/pneumatics)

**Magnetic Switches for T-Slot, Ø10 to 80mm**

- Series RST
- Series EST

Magnetic switches are used for electrical sensing of the position of the piston, e.g. at its end positions. They can also be used for sensing of intermediate positions.

Sensing is contactless, based on magnets which are built-in as standard. A yellow LED indicates operating status.

The universal magnetic switches are suitable for all PARKER-ORIGA OSP-Actuators and aluminum profile rod type cylinders.



**OSP**  
ORIGA  
SYSTEM  
PLUS

**Electrical Characteristics**

	Type RST	Type EST
Switching output	Reed	PNP
Operating voltage	10-30 VAC/DC	10-30 VDC
Ripple	–	≤ 10%
Voltage drop	≤ 3 V	≤ 2 V
Electrical configuration	2 wire	3 wire
Output function	normally open normally closed	normally open
Permanent current	≤ 100 mA	≤ 100 mA
Breaking capacity	≤ 6 peak W	–
Power consumption, at U <sub>B</sub> = 24V, switched on, without load	–	≤ 10 mA
Function indicator	LED, yellow (not for normally closed)	LED, yellow (not for normally closed)
Response time	≤ 2 ms	≤ 0.5 ms
Sensitivity	2 – 4 mT	2 – 4 mT
Time delay before availability	–	≤ 2 ms
Reverse polarity prot.	yes	yes
Short-circuit protection	no	yes (pulsed)
Switchable capacity load	µF	0.1 at 100 Ω, 24 VDC
Switching frequency	≤ 400 Hz	≤ 5 k
Repeatability	≤ 0.2mm	≤ 0.2mm
Hysteresis	≤ 1.5mm	≤ 1.5mm
EMC	EN 60947-5-2	EN 60947-5-2
Lifetime	≥ 35 Mio. cycles with PLC load	unlimited
Power-up pulse suppression	–	yes
Protection for inductive load	–	yes

**Mechanical Characteristics**

	Type RST	Type EST
Housing	Plastic / PA66 + PA6I red	
Cable cross section	2 x 0.14 mm <sup>2</sup>	3 x 0.14 mm <sup>2</sup>
Cable type	PUR, black	PUR, black
Bending radius	≥ 36mm	≥ 30mm
Weight (Mass)	ca. 0.030 kg (RST-K) ca. 0.010 kg (RST-S)	ca. 0.030 kg (EST-K) ca. 0.010 kg (EST-S)
Degree of protection	IP67 to EN 60529	
Ambient temperature range †	-25 to 80°C	-25 to 75°C at U <sub>B</sub> =10 – 30 V
– with adapter	-25 to 60°C	-25 to 80 °C at U <sub>B</sub> =10 – 28 V
Adapter tightening torque	0.15 Nm (tightening torque of screwing adapter)	
Shock resistance		
Vibration to EN 60068-2-6	G 15, 11 ms, 10 to 55 Hz, 1 mm	
Shock to EN 60068-2-27	G 50, 11 ms	
Bump to EN 60068-2-29	G 30, 11 ms, 1000 bumps each axis	

† For the magnetic switch temperature range, please take into account the surface temperature and the self-heating properties of the linear drive.

**G**

Rodless Pneumatic Cylinders

OSP-P Series

P1X Series

P1Z Series

GDL Series



For inventory, lead times, and kit lookup, visit [www.pdnplu.com](http://www.pdnplu.com)

G90

**Parker Hannifin Corporation**  
Pneumatic Division  
Richland, Michigan  
[www.parker.com/pneumatics](http://www.parker.com/pneumatics)



**Magnetic Switches RST and EST**

**Electrical Service Life Protective Measures**

Magnetic switches are sensitive to excessive currents and inductive inductions. With high switching frequencies and inductive loads such as relays, solenoid valves or lifting magnets, service life will be greatly reduced.

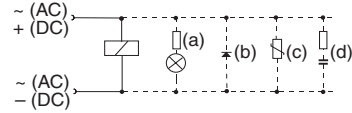
With **resistive and capacitive loads** with high switch-on current, such as light bulbs, a protective resistor should be fitted. This also applies to long cable lengths and voltages over 100 V.

In the switching of inductive loads such as relays, solenoid valves and lifting magnets, voltage peaks (transients) are generated which must be suppressed by protective diodes, RC loops or varistors.

**Connection Examples**

Load with protective circuits

- (a) Protective resistor for light bulb
- (b) Freewheel diode on inductively
- (c) Varistor on inductively
- (d) RC element on inductively



For the type EST, external protective circuits are not normally needed.

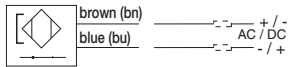
**Type RST**

In the type RST contact is made by a mechanical reed switch encapsulated in glass.

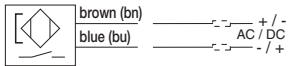
**Electrical Connection**

Type RST-K

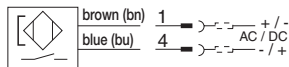
**Normally closed**



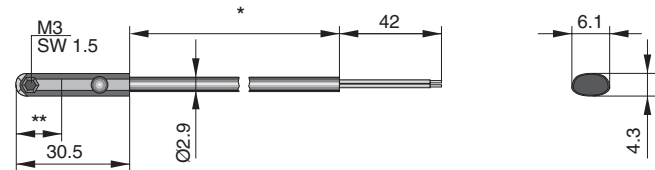
**Normally open**



Type RST-S



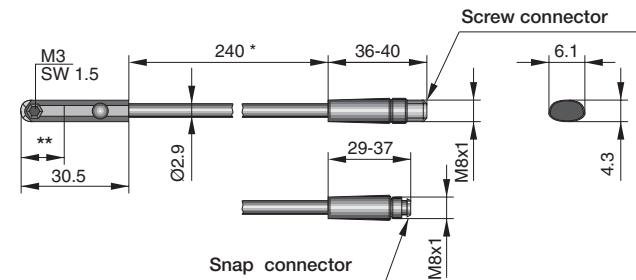
**Dimensions (mm) – Type RST-K, EST-K**



\* Cable lengths available: 5000 mm ± 75 mm  
 2000 mm ± 40 mm

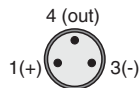
\*\* Switching point: Type RST-K Normally closed 14 mm  
 Type RST-K Normally open 12.3 mm  
 Type EST-K Normally open 8.1 mm

**Dimensions (mm) – Type RST-S, EST-S**



\* ± 6 mm

\*\* Switching point: Type RST-K Normally closed 14 mm  
 Type RST-K Normally open 12.3 mm  
 Type EST-K Normally open 8.1 mm



**PIN assignment**  
 (view of pins)  
 to DIN EN 50044

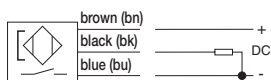
**Type EST**

In the type EST contact is made by an electronic switch – without bounce or wear and protected from pole reversal. The output is short circuit proof and insensitive to shocks and vibrations. Connection is by 3-pole connector for easy disconnection. Fitted with connection cable 100 mm long with connector.

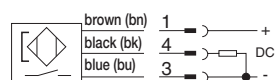
A 5 m cable with connector and open end can be ordered separately, or use the Order No. for the complete Type ES with 5 m cable.

**Electrical Connection**

Type EST-K



Type EST-S



Rodless Pneumatic Cylinders

OSP-P Series

P1X Series

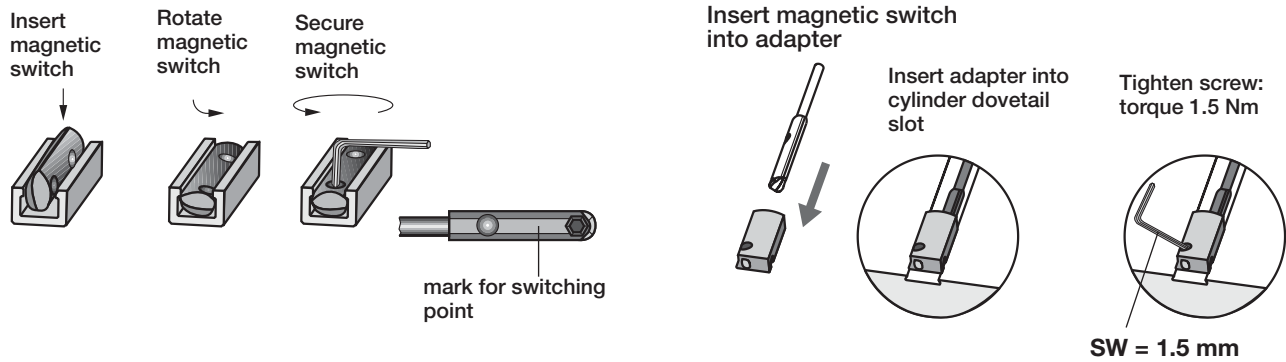
P1Z Series

GDL Series

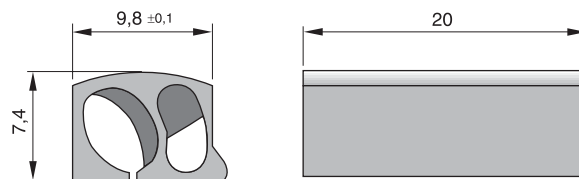


For inventory, lead time, and kit lookup, visit [www.pdnplu.com](http://www.pdnplu.com)

**Installation**



**Dimensions of Adapter for Magnetic Switch**



**Order Instructions**

Version	Voltage	Type	Part number
Magnetic switch, reed contact, normally open, LED indicator, cable 2 m	10-30 V AC / DC	RST-K	<b>P8S-GRFAX</b>
Magnetic switch, reed contact, normally open, LED indicator, cable 5 m	10-30 V AC / DC	RST-K	<b>P8S-GRFDX</b>
Magnetic switch, reed contact, normally open, snap connector M8, LED indicator, cable 0.24 m	10-30 V AC / DC	RST-S	<b>P8S-GRCHX</b>
Magnetic switch, reed contact, normally open, screw connector M8, LED indicator, cable 0.24 m	10-30 V AC / DC	RST-S	<b>P8S-GRCHX</b>
Magnetic switch, reed contact, normally closed, cable 5 m	10-30 V AC / DC	RST-K	<b>P8S-GEFRX</b>
Magnetic switch, electronic, PNP LED indicator, cable 2 m	10-30 V DC	EST-K	<b>P8S-GPFAX</b>
Magnetic switch, electronic, PNP LED indicator, cable 5 m	10-30 V DC	EST-K	<b>P8S-GPFDX</b>
Magnetic switch, electronic, PNP snap connector M8, LED indicator	10-30 V DC	EST-S	<b>P8S-GPCHX</b>
Magnetic switch, electronic, PNP screw connector M8, LED indicator	10-30 V DC	EST-S	<b>P8S-GPCHX</b>

Included in delivery:  
1 magnetic switch and 1 adapter for dovetail groove mounting

**Accessories**

Description	Type	Part number
Cable M8, 2.5 m without lock nut	KS25	<b>KY3240</b>
Cable M8, 5.0 m without lock nut	KS50	<b>KY3241</b>
Cable M8, 10.0 m without lock nut	KS100	<b>086620T010</b>
Cable M8, 2.5 m with lock nut	KSG25	<b>4041</b>
Cable M8, 5.0 m with lock nut	KSG50	<b>KC3104</b>
Adapter for dovetail groove (pack of 10)		<b>KL3333</b>

**G**  
 Rodless Pneumatic Cylinders  
 OSP-P Series  
 P1X Series  
 P1Z Series  
 GDL Series



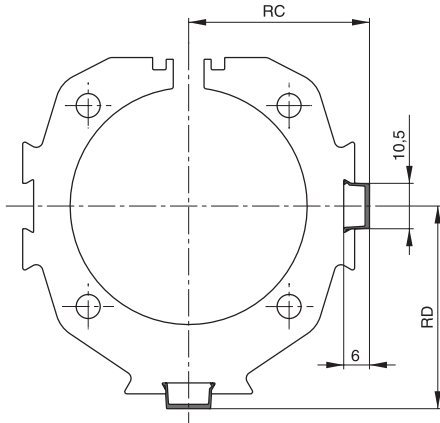
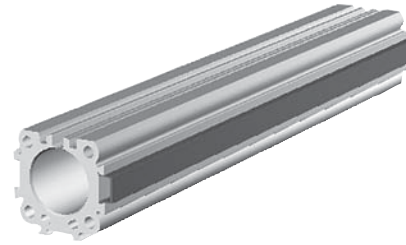
For inventory, lead times, and kit lookup, visit [www.pdnplu.com](http://www.pdnplu.com)

G92

**Parker Hannifin Corporation**  
 Pneumatic Division  
 Richland, Michigan  
[www.parker.com/pneumatics](http://www.parker.com/pneumatics)

**Dovetail Cover, Ø16 to 80mm**

- For clean guidance of magnetic switch cables along the cylinder body.
- Contains a maximum of 3 cables with diameter 3 mm.
- Material: Plastic
- Color: Red
- Temperature Range: -10 to 80°C



**Dimension (mm) and Order Instructions**

Series	Dimensions (mm)		Part number
	RC	RD	
OSP-P16	18.5	19	<b>13039FIL</b>  Minimal length: 1m Max. profile length: 2m  Multiple profiles can be used.
OSP-P25	23.5	25.5	
OSP-P32	29.5	32	
OSP-P40	34.5	37.5	
OSP-P50	41.5	46.5	
OSP-P63	51.5	57.5	
OSP-P80	64.5	70.5	

**Metric Conversion Fittings**



Bore Size	Port Size	Part number
P25	G1/8 to 1/8" NPT	<b>2521-1/8-02</b>
P32, P40, P50	G1/4 to 1/4" NPT	<b>2521-1/4-04</b>
P63	G3/8 to 3/8" NPT	<b>2521-3/8-06</b>
P80	G1/2 to 1/2" NPT	<b>2521-1/2-08</b>



Rodless Pneumatic Cylinders

OSP-P Series

P1X Series

P1Z Series

GDL Series



For inventory, lead time, and kit lookup, visit [www.pdnplu.com](http://www.pdnplu.com)

G93

**Parker Hannifin Corporation**  
 Pneumatic Division  
 Richland, Michigan  
[www.parker.com/pneumatics](http://www.parker.com/pneumatics)

**Service Packs**

	Bore sizes							
	10mm	16mm	25mm	32mm	40mm	50mm	63mm	80mm
BUNA service pack single piston	3085x(stroke)	11111x(stroke)	11112x(stroke)	11113x(stroke)	11114x(stroke)	11115x(stroke)	11116x(stroke)	11118x(stroke)
Fluorocarbon service pack, single piston	3086x(stroke)	11121x(stroke)	11122x(stroke)	11123x(stroke)	11124x(stroke)	11125x(stroke)	11126x(stroke)	11128x(stroke)
BUNA service pack single piston - slow speed grease	—	11131x(stroke)	11132x(stroke)	11133x(stroke)	11134x(stroke)	11135x(stroke)	11136x(stroke)	11138x(stroke)
Fluorocarbon service pack, single piston - slow speed grease	—	11141x(stroke)	11142x(stroke)	11143x(stroke)	11144x(stroke)	11145x(stroke)	11146x(stroke)	11148x(stroke)

**Note:** (stroke) = stroke of cylinder in mm

**Service Pack Information**


Service Packs contain all the components necessary to completely rebuild a Parker rodless cylinder, are available. Each pack contains a complete seal kit, inner and outer bands, Parker grease tube, cleaning tool and repair instructions. It's all packaged in an easy-to-ship, easy-to-store box clearly labeled to indicate the cylinder type, bore and stroke for which it is intended. Contact your local Parker distributor for more information.

**Seal & Service Kits**

	Bore sizes						
	16mm	25mm	32mm	40mm	50mm	63mm	80mm
BUNA seal kit - standard cylinder	11052	11053	11054	11055	11056	11057	11058
Fluorocarbon seal kit - standard cylinder	11059	11060	11061	11062	11063	11064	11065
Service kit active brake - sideline carriage	—	11095	11096	11097FIL	11098FIL	—	—
Service kit active brake - standard cylinder	—	11822FIL	11823FIL	11824FIL	11825FIL	11826FIL	11827FIL
Service kit - multibrake	—	11089FIL	11090FIL	11091FIL	11092FIL	11093FIL	—

**Seal Kit Information**

Seal Kits include all seals, a tube of grease, bearing shoe, scraper and cleaning tool.

  
 Rodless Pneumatic Cylinders  
 OSP-P Series  
 P1X Series  
 P1Z Series  
 GDL Series



For inventory, lead times, and kit lookup, visit [www.pdnplu.com](http://www.pdnplu.com)

**Displacement Measuring System for Automated Movement**

**Series SFI-plus (incremental measuring system) for cylinder series**

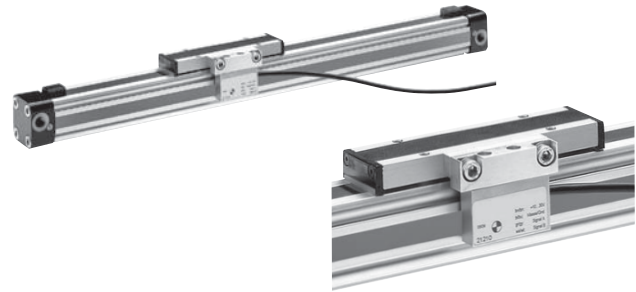
- OSP-P...

**Characteristics**

- Contactless magnetic displacement measurement system
- Displacement length up to 5.5 m
- Resolution 0.1 mm (option: 1 mm)
- Displacement speed up to 10 m/s
- For linear and non-linear rotary motion
- Suitable for almost any control or display unit with a counter input

The SFI-plus magnetic displacement measuring system consists of 2 main components.

- **Measuring Scale**, self-adhesive magnetic measuring scale



- **Sensing Head**, converts the magnetic poles into electrical signals which are then processed by counter inputs downstream (e.g. PLC, PC, digital counter)

**Note:** For combinations Active Brake AB + SFI-plus + Magnetic Switch contact our technical department please.

**Characteristics**

	Type 21210FIL	Type 21211FIL
<b>Output Function</b>		
Resolution	0.1mm	1mm
Pole lengths magnetic scale	5mm	5mm
Maximum speed	10 m/s	10 m/s
Repeat accuracy	± 1 Increment	± 1 Increment
Distance between sensor and scale	≤ 4mm	≤ 4mm
Tangential deviation	≤ 5°	≤ 5°
Lateral deviation	≤ ± 1.5 mm	≤ ± 1.5 mm
Switching output	PNP	PNP
<b>Electrical Characteristics</b>		
Operating voltage $U_b$	18 – 30 V DC	18 – 30 V DC
Voltage drop	≤ 2 V	≤ 2 V
Continuous current for each output	≤ 20 mA	≤ 20 mA
Power consumption at $U_b = 24V$ , switched on, without load	≤ 50 mA	≤ 50 mA
Short-circuit protection	yes	yes
Reverse polarity protection	–	yes
Protection from inductive load	yes	yes
Power-up pulse suppression	yes	yes

	Type 21210FIL / 21211FIL
<b>EMC</b>	
Electrostatic discharge immunity	6, B, to EN 61000-4-2 kV
Electromagnetic field immunity	10, A, to EN61000-4-3 V/m
Electrical fast transient/burst immunity (for signal connections)	1, B, to EN 61000-4-4 kV
Electrical fast transient/burst immunity (for DC connections)	2, B, to EN 61000-4-4 kV
Surge immunity (for signal connections)	1, B, to EN 61000-4-5 kV
Surge immunity (for DC connections)	0,5, B, to EN 61000-4-5 kV
Immunity to conducted disturbances	10, A, to EN 61000-4-6 V
Power frequency magnetic field immunity at 50 Hz	30, A, to EN 61000-4-8 A/m
Emission standard for residential	to EN 61000-6-4
Radio disturbance characteristics	to EN 55011, Group 1, A
<b>Mechanical Characteristics</b>	
Housing	Aluminum
Cable length	5.0 m – fixed, open end
Cable cross section	4 x 0.14 mm <sup>2</sup>
Cable type	PUR, black
Bending radius	≥ 36 mm
Weigh (mass)	ca. 0.165 kg
<b>Environmental Conditions / Shock Resistance</b>	
Degree of protection	IP67 to EN60529
Ambient temperature range	-25°C to 80°C
Broad-band random vibration to EN 60068-2-64	5 g, 5 Hz to 2 kHz, 0.5 h each axis
Vibration stress to EN 60068-2-6	12 g, 10 Hz to 2 kHz, 2 mm, 5 h each axis
Shock to EN 60068-2-27	100 g, 6 ms, 50 bumps each axis
Bump to EN 60068-2-29	5 g, 2 ms, 8000 bumps each axis



Rodless Pneumatic Cylinders

OSP-P Series

P1X Series

P1Z Series

GDL Series



For inventory, lead time, and kit lookup, visit [www.pdnplu.com](http://www.pdnplu.com)

G95

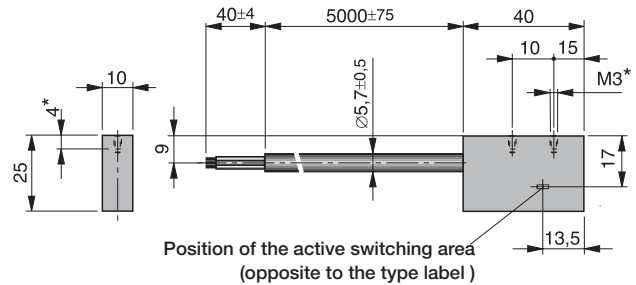
**Parker Hannifin Corporation**  
Pneumatic Division  
Richland, Michigan  
[www.parker.com/pneumatics](http://www.parker.com/pneumatics)

**Sensing Head**

The sensing head provides two pulsating, 90° out of phase counter signals (phase A/B) with a 0.4 mm resolution (option 4 mm).

External processing can improve the resolution to 0.1 mm (option 1 mm).

The counting direction can be determined automatically from the phase variance of the counter signals.

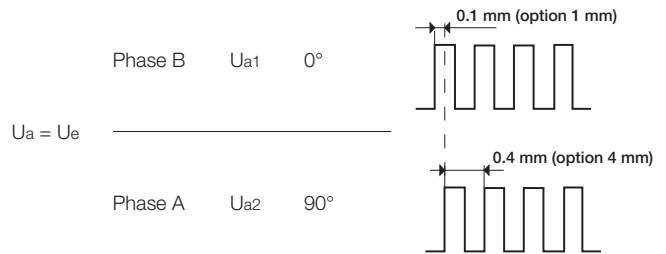


\* Maximum thread depth 4mm

**Electrical Connection**

Color7	Description
RD = Red	10-30 VDC
BL = Black	Ground
YE = Yellow	Phase A
GN = Green	Phase B

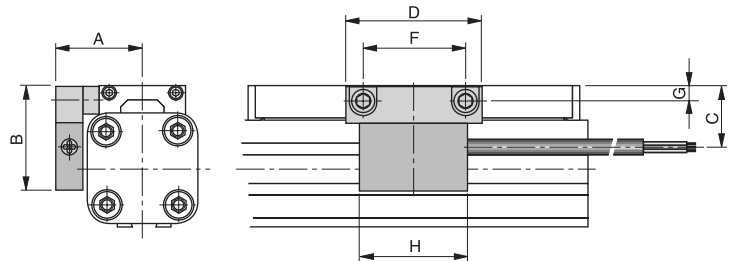
**Output signal – Sensing Head**



**SFI-plus mounted on a rodless cylinder series OSP-P**

The SFI-plus system can be mounted directly on a rodless OSP-P cylinder with the special mounting kit.

The position of the sensing head is generally 90° to the carrier.



**Combinations consisting of SFI-plus and OSP-P Cylinders with guides are available on request.**

**Dimension (mm)**

Series	A	B	C	D	F	G	H
OSP-P25	32	39	23	50	38	5.5	40
OSP-P32	37.5	46	30	50	38	6.5	40
OSP-P40	42.5	50	34	50	38	6.5	40
OSP-P50	49.5	55	39	50	38	6.5	40
OSP-P63	59.5	65	49	50	38	10	40
OSP-P80	72.5	80	64	50	38	12	40

**G**  
 Rodless Pneumatic Cylinders  
 OSP-P Series  
 P1X Series  
 P1Z Series  
 GDL Series



For inventory, lead times, and kit lookup, visit [www.pdnplu.com](http://www.pdnplu.com)

**Order instructions**

Description	Part number
Sensing head with measuring scale – Resolution 0.1 mm (scale length = required measuring distance + a minimum of – see table below)	<b>21240x(stroke)</b>
Option: Sensing head with measuring scale – Resolution 1 mm (scale length = required measuring distance + a minimum of – see table below)	<b>21241x(stroke)</b>
Sensing head – Resolution 0.1 mm (spare part)	<b>21210FIL</b>
Option: Sensing head – Resolution 1 mm (spare part)	<b>21211FIL</b>
Measuring scale per meter (spare part)	<b>21235FIL</b>
Mounting kit for OSP-P25	<b>21213FIL</b>
Mounting kit for OSP-P32	<b>21214FIL</b>
Mounting kit for OSP-P40	<b>21215FIL</b>
Mounting kit for OSP-P50	<b>21216FIL</b>
Mounting kit for OSP-P63	<b>21217FIL</b>
Mounting kit for OSP-P80	<b>21218FIL</b>

\* Overall length of the measuring scale results from stroke length of the cylinder + dead length  
Dead length for linear drives series OSP-P see table.

Series	Dead length (mm)
<b>OSP-P 25</b>	154
<b>OSP-P 32</b>	196
<b>OSP-P 40</b>	240
<b>OSP-P 50</b>	280
<b>OSP-P 63</b>	350
<b>OSP-P 80</b>	422

**Example:**

Cylinder OSP-P, Ø25 mm, stroke length 1000 mm

$$\begin{array}{rcl}
 \text{dead length} & + & \text{stroke length} & = & \text{overall length of the measuring scale} \\
 154 \text{ mm} & + & 1000 \text{ mm} & = & 1154 \text{ mm}
 \end{array}$$



Rodless Pneumatic Cylinders

OSP-P Series

P1X Series

P1Z Series

GDL Series

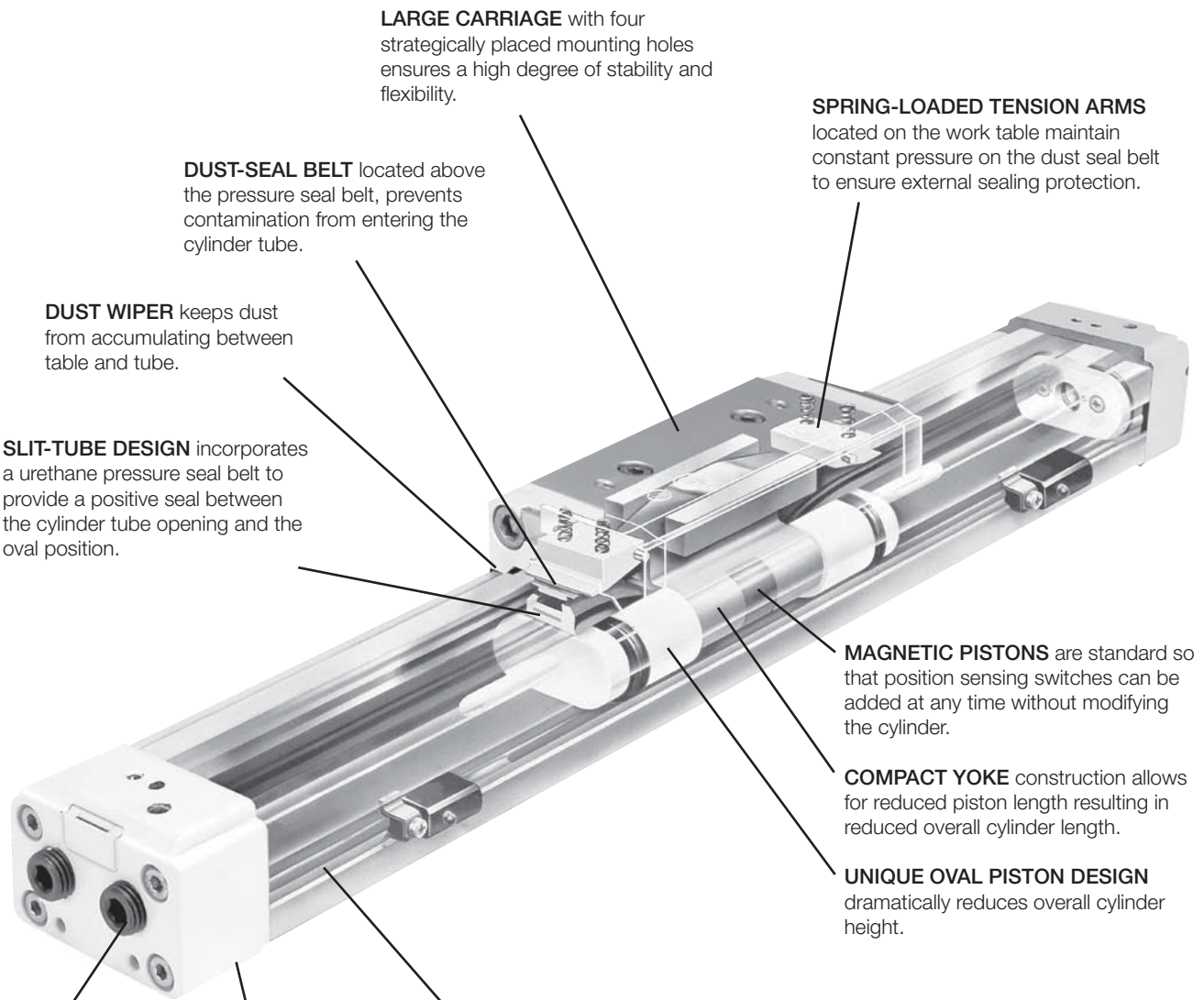


For inventory, lead time, and kit lookup, visit [www.pdnplu.com](http://www.pdnplu.com)

G97

**Parker Hannifin Corporation**  
Pneumatic Division  
Richland, Michigan  
[www.parker.com/pneumatics](http://www.parker.com/pneumatics)

**P1X Series**



**LARGE CARRIAGE** with four strategically placed mounting holes ensures a high degree of stability and flexibility.

**DUST-SEAL BELT** located above the pressure seal belt, prevents contamination from entering the cylinder tube.

**DUST WIPER** keeps dust from accumulating between table and tube.

**SLIT-TUBE DESIGN** incorporates a urethane pressure seal belt to provide a positive seal between the cylinder tube opening and the oval position.

**SPRING-LOADED TENSION ARMS** located on the work table maintain constant pressure on the dust seal belt to ensure external sealing protection.

**MAGNETIC PISTONS** are standard so that position sensing switches can be added at any time without modifying the cylinder.

**COMPACT YOKE** construction allows for reduced piston length resulting in reduced overall cylinder length.

**UNIQUE OVAL PISTON DESIGN** dramatically reduces overall cylinder height.

**ADDITIONAL PORTS IN ONE END CAP** for optional piping location.

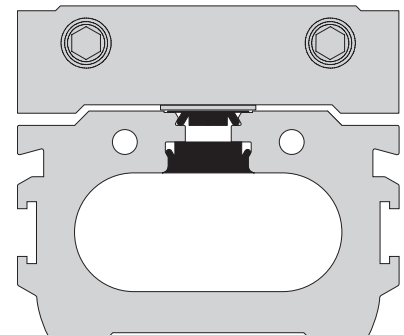
**Note:** End cap ports shown on this view are for representation only. Actual end ports are at other end of cylinder in relation to standard side ports and end ports are normally furnished plugged.

**INTEGRAL SWITCH MOUNTING RAIL** provides convenient mounting location for position sensing switches. Switches available include Solid State and Reed, AC or DC, with or without indicator lights. Bi-Color switches are available with 2 indicators to identify when maximum efficiency of contact is made.

**ADJUSTABLE CUSHIONS** for deceleration at end of stroke are standard.

**Oval Piston Design**

Oval piston design provides greater load carrying capacity than typical Rodless Pneumatic Cylinders with round pistons.



 Rodless Pneumatic Cylinders	OSP-P Series
	P1X Series
	P1Z Series
	GDL Series



For inventory, lead times, and kit lookup, visit [www.pdnplu.com](http://www.pdnplu.com)

G98

**Parker Hannifin Corporation**  
Pneumatic Division  
Richland, Michigan  
[www.parker.com/pneumatics](http://www.parker.com/pneumatics)



## Features

- 7 bore sizes – 16mm through 63mm
- Two port locations standard
- Large carriage for stability
- Integral sensor mounting rail
- Optional adjustable stroke and shock absorbers
- Maximum stroke 5000mm

## Rodless Pneumatic Cylinders P1X Series



### Operating information

Maximum pressure:	100 PSIG (7 bar)						
Minimum pressure:	<table border="0"> <tr> <td>Ø16, Ø20 bores</td> <td>29 PSI (2 bar)</td> </tr> <tr> <td>Ø25, Ø32, Ø40 bores</td> <td>14.5 PSI (1 bar)</td> </tr> <tr> <td>Ø50, Ø63 bores</td> <td>7 PSI (0.5 bar)</td> </tr> </table>	Ø16, Ø20 bores	29 PSI (2 bar)	Ø25, Ø32, Ø40 bores	14.5 PSI (1 bar)	Ø50, Ø63 bores	7 PSI (0.5 bar)
Ø16, Ø20 bores	29 PSI (2 bar)						
Ø25, Ø32, Ø40 bores	14.5 PSI (1 bar)						
Ø50, Ø63 bores	7 PSI (0.5 bar)						
Proof pressure:	152 PSI (10.5 bar)						
Temperature range:	40°F to 140°F (5°C to 60°C)						
Filtration requirements:	Filtered, nonlubricated compressed air						

### Ordering Information

<b>P1X</b>	<b>N</b>	<b>032</b>	<b>D</b>	<b>A</b>	<b>N</b>	<b>0500</b>	<b>W</b>	<b>D</b>	<b>N</b>	<b>N</b>	<b>N</b>	<b>-B</b>
Series			Carriage			Stroke length*			Porting options			
P1X Global Rodless			D Double acting		Seal material		Basic or options		N NPTF (Std) G BSPP Q BSPT*			
	Construction				N Standard		B† Standard W† With options / Special (for factory use only)		* Not available with N construction			
	N Inch M Metric							Carriage mounting style				
		Bore size		Piston / Shock style				D Basic mount A Swivel mount G Inverted swivel mount				
		016 16mm 020 20mm 025 25mm 032 32mm 040 40mm 050 50mm 063 63mm		A Cushions both ends (standard) R Cushion right end only* L Cushion left end only* N No cushions or shock absorbers H Shock absorber both ends B Shock absorber right end only C Shock absorber left end only								
				* As viewed from port side of cylinder								
									Mounting options			
									No Foot mount End mount foot bracket Bottom mount foot bracket Intermediate supports			
									N (std) F A†† H M B†† K P C†† T R D††			
										Fastener Type		
										N Standard - zinc-plated S Stainless steel		
											Sensors	
											See section L for sensors.	

\* Stroke is ALWAYS in mm.  
 † When "B" is specified, the remaining digits in the part number are not necessary. If "W" is used, the remaining digits in the part number must be filled out.  
 †† Not available on 40, 50 and 63mm bore sizes.

Essential Information  
 Optional Features

G

Rodless Pneumatic Cylinders

OSP-P Series

P1X Series

P1Z Series

GDL Series



For inventory, lead time, and kit lookup, visit [www.pdnplu.com](http://www.pdnplu.com)

G99

**Parker Hannifin Corporation**  
 Pneumatic Division  
 Richland, Michigan  
[www.parker.com/pneumatics](http://www.parker.com/pneumatics)

**Specifications - P1X (standard with switch)**

- Operating Medium: Compressed Air
- Bore Size mm (inch nominal): 16 (5/8)      20 (3/4), 25 (1)      32 (1-1/4), 40 (1-1/2)      50 (2), 63 (2-1/2)
- Port Size – N Series: M5 (10-32)      1/8 NPT      1/4 NPT      3/8 NPT
- Port Size – M Series: M5 (10-32)      1/8 Rc      1/4 Rc      3/8 Rc
- Stroke Tolerance in.: ±0.080 to 39"    ±0.100 to 118"    ±0.120 to 196"
- Piston Speed, \*in./sec.: 2-80 IPS with side ports on each end  
(Ø16 & Ø20 bores 2-40 IPS with single end porting with 39" stroke)  
(Ø25, Ø32, Ø40, Ø50 & Ø63 bores 2-40 IPS with single end porting with 78" stroke)
- Cushion: Air Cushion Standard
- Lubrication: Not Required (if you choose to lubricate your system, continuing lubrication will be required.)

\*Note: Actual piston speed with one end ports will vary depending on stroke length.

**Weight & Theoretical Force Characteristics**

		Weights								Theoretical Force (lbs)				
		Weight at Zero Stroke						Weight per 1" (25.4mm) Stroke		at Pressure (PSI)				
Bore	Area In <sup>2</sup>	M00		MLB		MLB1		lbs	kg	30	40	60	80	100
		lbs	kg	lbs	kg	lbs	kg							
16	0.31	0.70	0.3	0.73	0.3	0.77	0.4	0.07	0.03	9	12	19	25	31
20	0.49	1.15	0.5	1.19	0.5	1.28	0.6	0.10	0.04	15	20	29	39	49
25	0.84	2.21	1.0	2.43	1.1	2.43	1.1	0.15	0.07	23	30	46	61	76
32	1.26	3.31	1.5	3.53	1.6	3.75	1.7	0.20	0.09	38	50	69	100	125
40	1.96	5.29	2.4	5.51	2.5	—	—	0.27	0.12	59	78	117	156	195
50	3.08	7.94	3.6	8.16	3.7	—	—	0.40	0.18	91	122	182	243	304
63	4.86	13.67	6.2	14.33	6.5	—	—	0.63	0.28	145	193	290	386	483

**Replacement Seal Kits  
(includes inner & outer bands)**

Bore (mm)	Part number
16	L079020016-(stroke)
20	L079020020-(stroke)
25	L080100025-(stroke)
32	L080100032-(stroke)
40	L080100040-(stroke)
50	L080100050-(stroke)
63	L080100063-(stroke)

**G**  
 Rodless Pneumatic Cylinders  
 OSP-P Series  
 P1X Series  
 P1Z Series  
 GDL Series



For inventory, lead times, and kit lookup, visit [www.pdnplu.com](http://www.pdnplu.com)

G100

**Parker Hannifin Corporation**  
 Pneumatic Division  
 Richland, Michigan  
[www.parker.com/pneumatics](http://www.parker.com/pneumatics)

**Moments**

Figure 1 shows the maximum allowable moments for each of the three types of loading: pitch, roll and yaw.

The sum total of each of these types of moments, divided by each of the maximum values, determines a Load-Moment Factor (LMF) should be equal to or less than 1.0. On horizontal mountings, the total load (L) should also be divided by the maximum load allowable (Figure 2) and factored into the equation.

Horizontal mountings:

$$\frac{L}{[L]} + \frac{M}{[M]} + \frac{Ms}{[Ms]} + \frac{Mv}{[Mv]} = LMF \leq 1.0$$

Vertical mountings:

$$\frac{M}{[M]} + \frac{Ms}{[Ms]} + \frac{Mv}{[Mv]} = LMF \leq 1.0$$

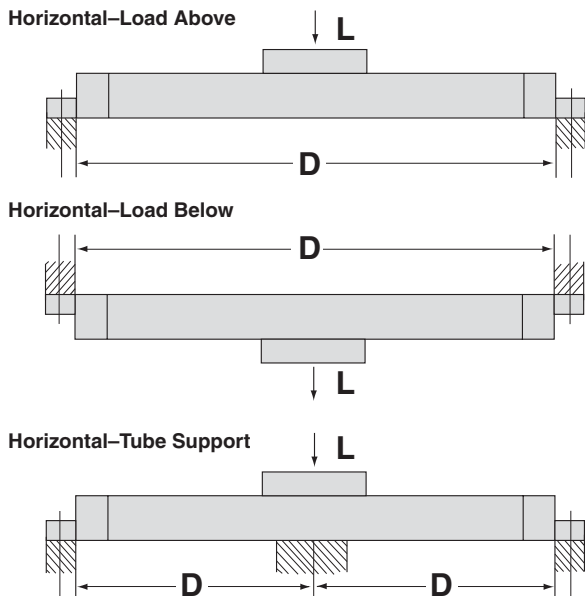
**Figure 1**

Maximum allowable moments n-m (lb-in)

Bore size	[M]		[Ms]		[Mv]	
	Pitch moment		Roll moment		Yaw moment	
	Std.	Inverted	Std.	Inverted	Std.	Inverted
16	5 (44)	3.5 (31)	1 (9)	0.5 (4)	1 (9)	1 (9)
20	10 (89)	7 (62)	1.5 (13)	0.7 (6)	3 (27)	3 (27)
25	17 (150)	12 (106)	5 (44)	2.5 (22)	10 (89)	10 (89)
32	36 (319)	25 (221)	10 (89)	5 (44)	21 (186)	21 (186)
40	77 (682)	54 (478)	23 (204)	11.5 (102)	26 (230)	26 (230)
50	154 (1363)	108 (956)	32 (283)	16 (142)	42 (372)	42 (372)
63	275 (2434)	193 (1708)	52 (460)	26 (230)	76 (673)	76 (673)

**Load and Deflection**

Figure 2 shows the maximum load [L] that the cylinder can accept, as well as the maximum length [D] between supports at the maximum load.

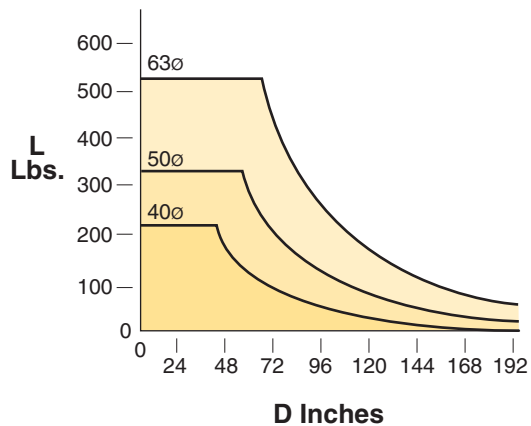
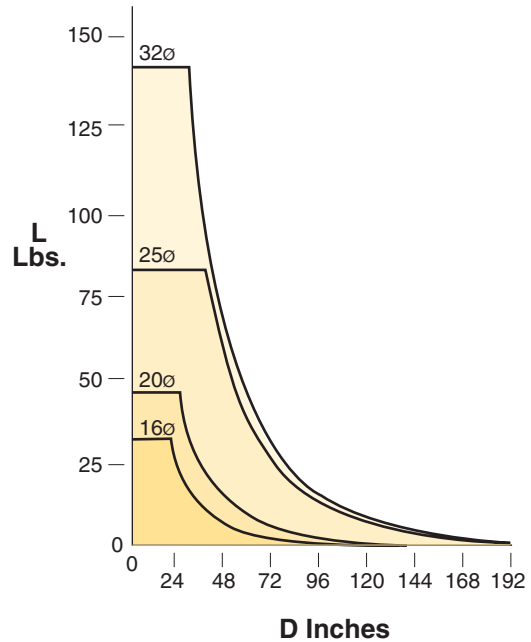


**Figure 2**

Bore size	Max. allowable load [L] N (lbs)		Max. unsupported length mm (in) at max. load
	Std.	Inverted	
16	141 (32)	70 (16)	450 (17.7)
20	198 (45)	101 (23)	551 (21.7)
25	356 (81)	180 (41)	899 (35.4)
32	616 (140)	308 (70)	749 (29.5)
40	959 (218)	480 (109)	1000 (39.4)
50	1456 (331)	726 (165)	1300 (51.2)
63	2297 (522)	1148 (261)	1600 (63.0)

Acceptable length and load combinations for various bore sizes can be determined from the charts in Figure 3.

**Figure 3**



To determine cylinder deflections under the load (or resistive force perpendicular to the piston table) without mid-support, see the graphs on page G103.

**G**  
 Rodless Pneumatic Cylinders  
 OSP-P Series  
 P1X Series  
 P1Z Series  
 GDL Series



For inventory, lead time, and kit lookup, visit [www.pdnplu.com](http://www.pdnplu.com)

**Inertia Moment Consideration**

When the weight is stopped at the end of the stroke by the cylinder cushion, inertial force is created. This inertial force (Fi) can be determined by using the formula:

**Fi = LG**

**L** = Load attached to the cylinder carriage (lbs.)

**G** = Inertia factor (Figure 1)

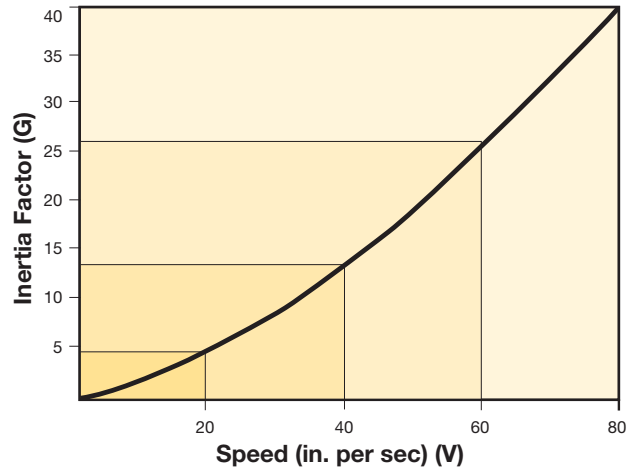
**Example:**

A speed of 40 in/sec corresponds to an inertia factor G of 13.

The inertial force calculated would then be multiplied by the distance from the center of gravity of the load to the centerline of the cylinder, and added to the previously calculated M and Mv moments. This will give an M Total and Mv Total. Ensure that the M Total and the Mv Total do not exceed the [M] and [Mv] values shown in Figure 5 (previous page). If they exceed these values, consult the factory.

See pages G112-G114 for additional information on shock absorbers.

**Figure 1**

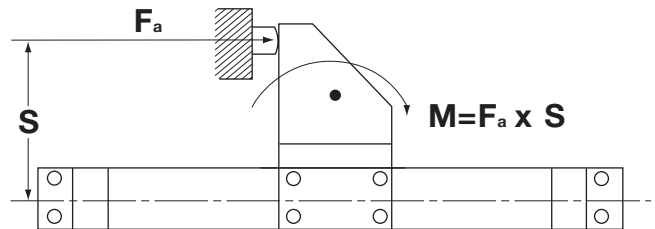


**External Stops**

When the load attached to the cylinder is stopped externally, it creates an additional moment equal to the cylinder force (Fa) times the distance (S). This additional moment, plus the previously calculated Load-Moment factor, should not exceed the allowable values. See previous page.

When reducing the stroke with external stops, remember that the cushion length and the energy absorption capacity are not directly proportional. Reducing the cushioning distance by 50% corresponds to a reduction of 60-70% in cushion effectiveness.

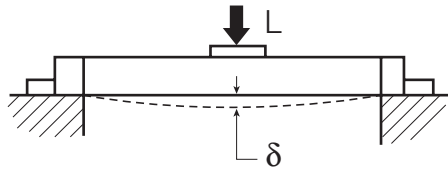
**Figure 9**



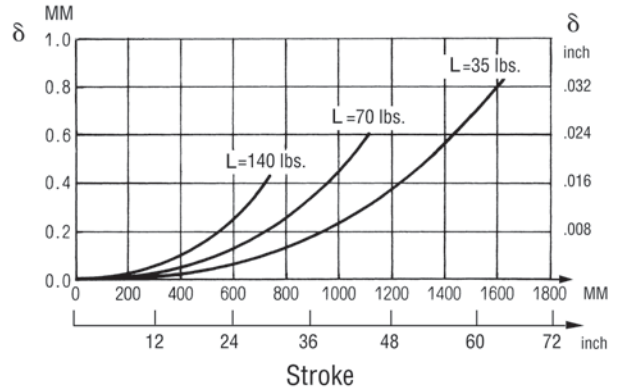
<b>G</b> Rodless Pneumatic Cylinders	OSP-P Series
	P1X Series
	P1Z Series
	GDL Series



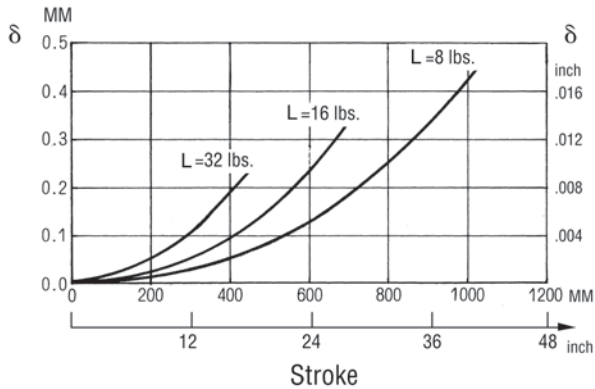
For inventory, lead times, and kit lookup, visit [www.pdnplu.com](http://www.pdnplu.com)



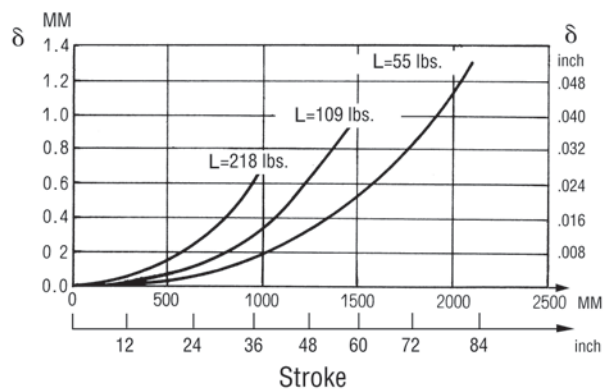
**32 mm Bore**



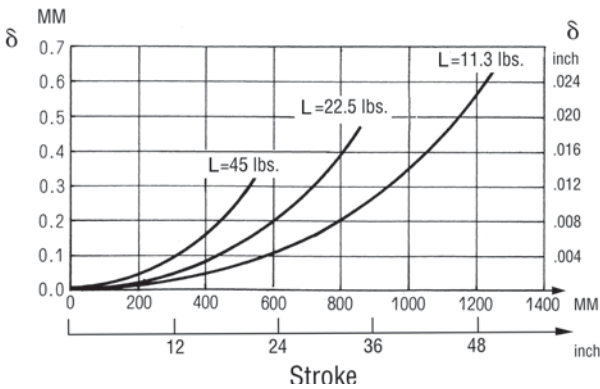
**16 mm Bore**



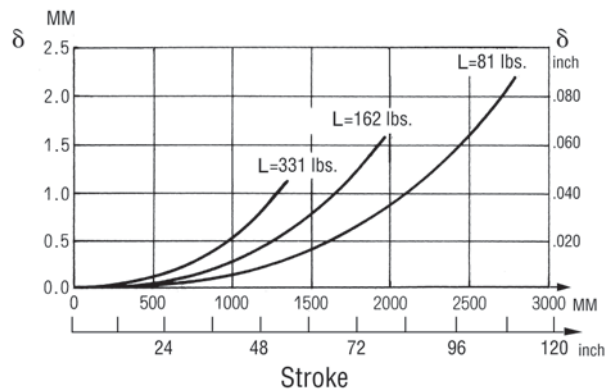
**40 mm Bore**



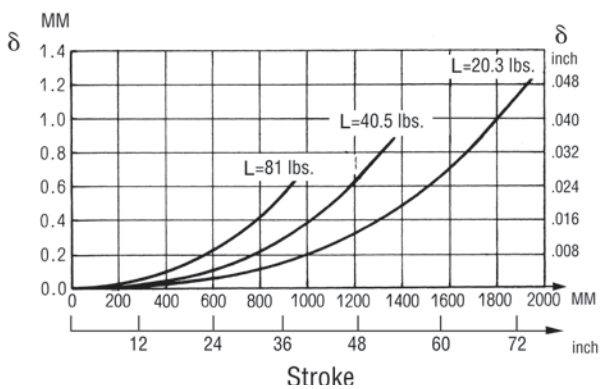
**20 mm Bore**



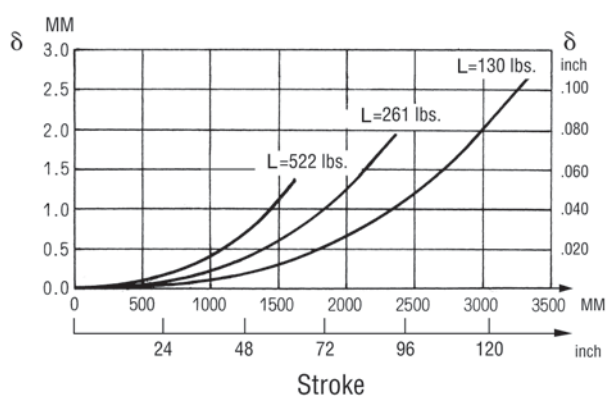
**50 mm Bore**



**25 mm Bore**



**63 mm Bore**



Rodless Pneumatic Cylinders

OSP-P Series

P1X Series

P1Z Series

GDL Series

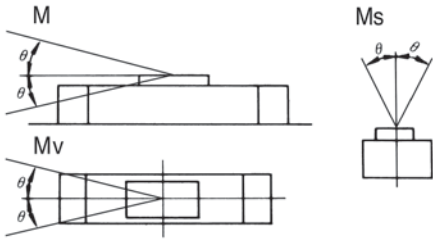


For inventory, lead time, and kit lookup, visit [www.pdnplu.com](http://www.pdnplu.com)

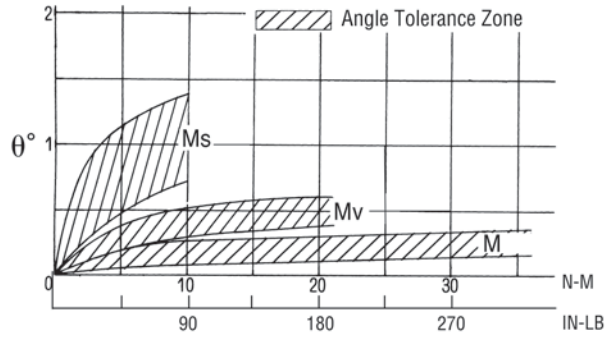
G103

**Parker Hannifin Corporation**  
 Pneumatic Division  
 Richland, Michigan  
[www.parker.com/pneumatics](http://www.parker.com/pneumatics)

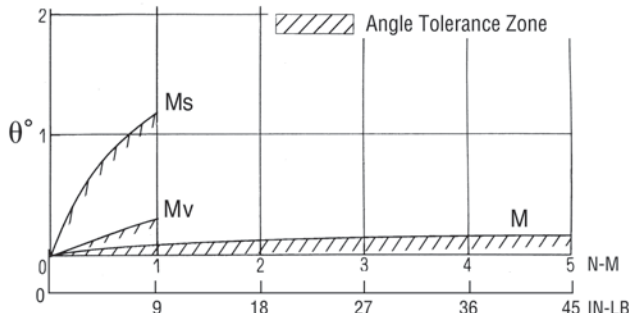
**Piston Table Angular Deflection Due To Load Moments Applied**



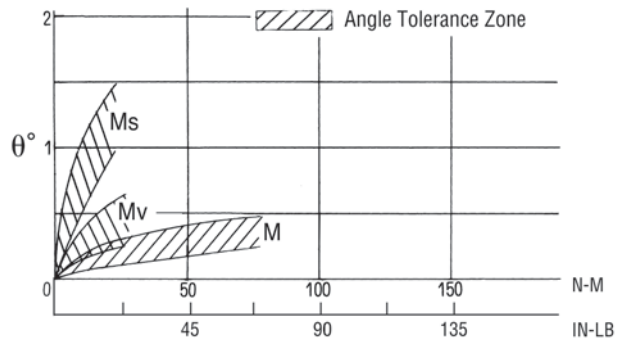
**32 mm Bore**



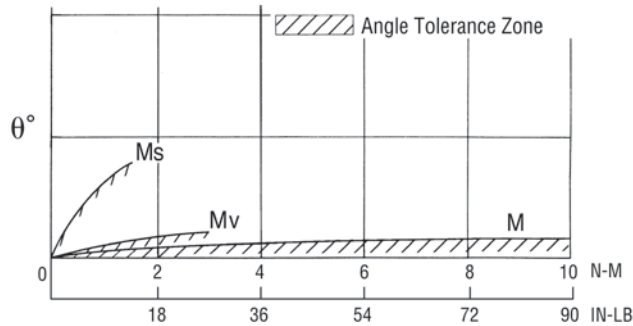
**16 mm Bore**



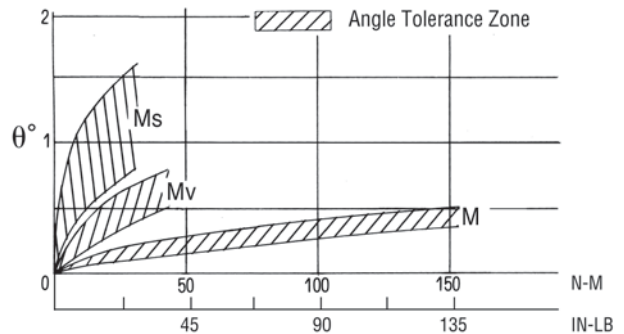
**40 mm Bore**



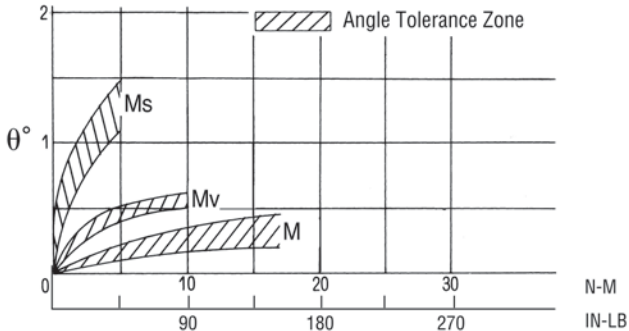
**20 mm Bore**



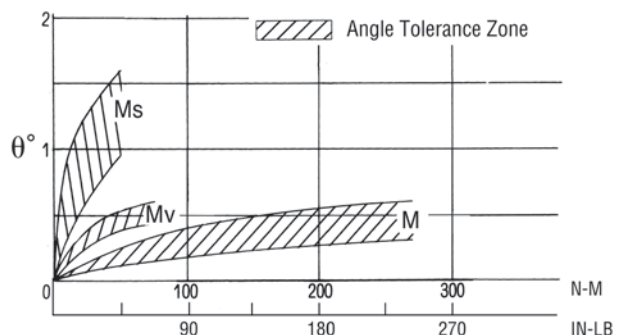
**50 mm Bore**



**25 mm Bore**



**63 mm Bore**



**G**  
 Rodless Pneumatic Cylinders  
 OSP-P Series  
 P1X Series  
 P1Z Series  
 GDL Series

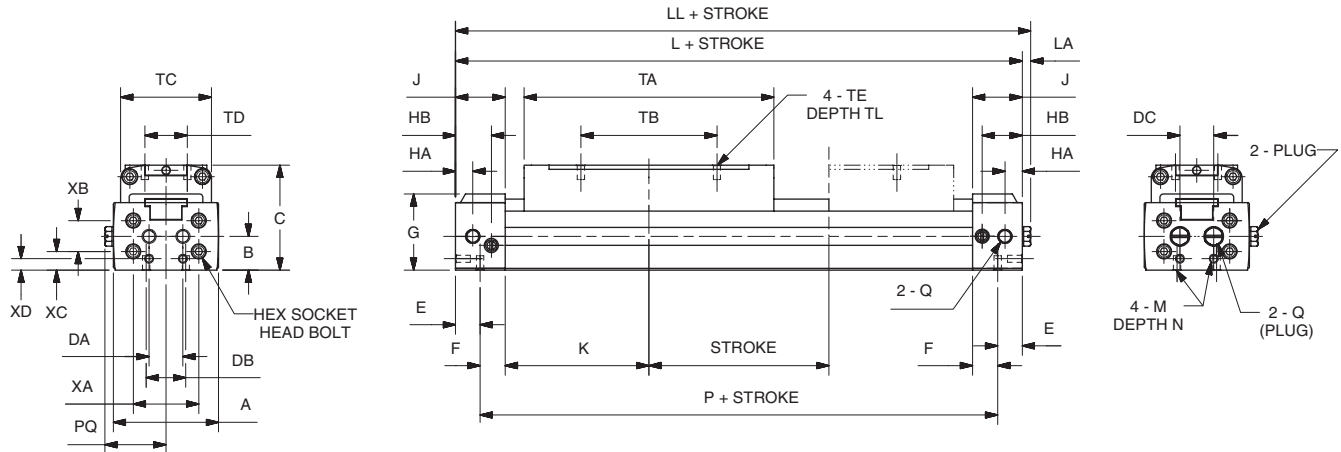


For inventory, lead times, and kit lookup, visit [www.pdnplu.com](http://www.pdnplu.com)

G104

**Parker Hannifin Corporation**  
 Pneumatic Division  
 Richland, Michigan  
[www.parker.com/pneumatics](http://www.parker.com/pneumatics)

**Basic Cylinder**



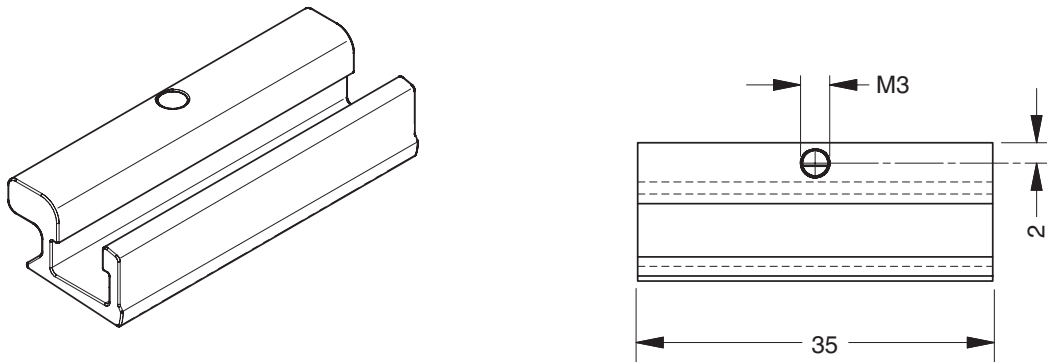
Bore (mm)	A	B	C	DA	DB	DC	E	F	G	HA	HB	J	K	L	LL	LA	M	N
16	1.46 (37)	0.47 (12)	1.46 (37)	0.47 (12)	0.55 (14)	0.47 (12)	0.34 (8.5)	0.35 (9)	1.06 (27)	0.24 (6)	0.55 (14)	0.69 (17.5)	2.24 (57)	5.87 (149)	5.98 (152)	0.12 (3)	5-40 (M3)	0.20 (5)
20	1.73 (44)	0.55 (14)	1.65 (42)	0.55 (14)	0.63 (16)	0.63 (16)	0.41 (10.5)	0.45 (11.5)	1.22 (31)	0.34 (8.5)	0.73 (18.5)	0.87 (22)	2.46 (62.5)	6.65 (169)	6.75 (171.5)	0.10 (2.5)	8-32 (M4)	0.26 (6.5)

Bore (mm)	P	PQ	Q	TA	TB	TC	TD	TE	TL	XA	XB	XC	XD
16	5.20 (132)	0.83 (21)	10-32 NPT (M5)	3.47 (88)	1.89 (48)	1.26 (32)	0.59 (15)	5-40 (M3)	0.20 (5)	0.91 (23)	0.43 (11)	0.26 (6.5)	0.16 (4)
20	5.83 (148)	0.97 (24.5)	1/8 NPT (1/8 Rc)	3.94 (100)	2.36 (60)	1.50 (38)	0.71 (18)	8-32 (M4)	0.24 (6)	1.10 (28)	0.63 (16)	0.24 (6)	0.20 (5)

inches (mm)

**Sensor adapter bracket**

**Part number P8S-TMA0Y**  
(Shown larger than actual size)



NOTE: Must be ordered separately when ordering sensors.

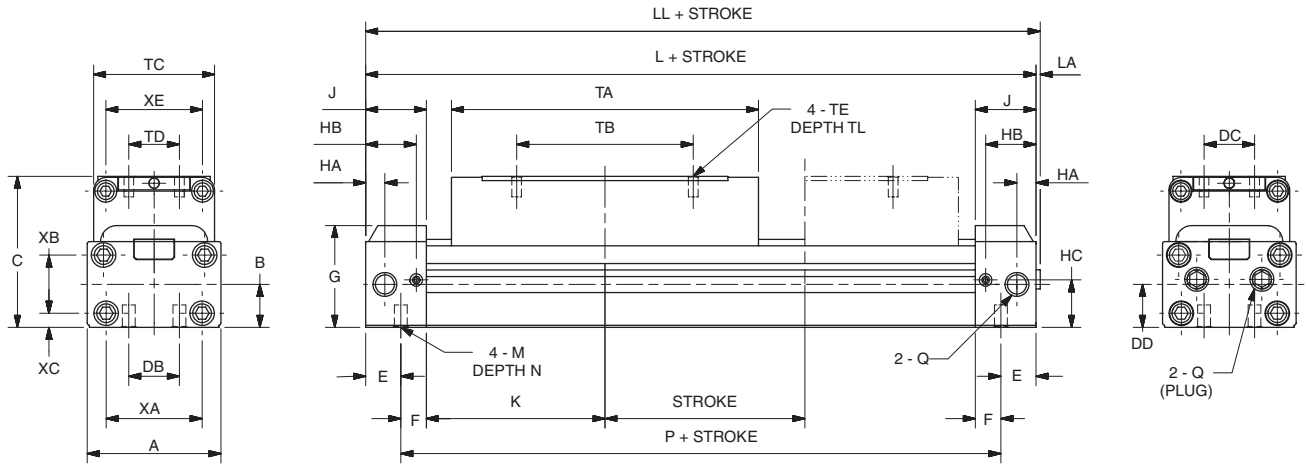


For inventory, lead time, and kit lookup, visit [www.pdnplu.com](http://www.pdnplu.com)

G105

**Parker Hannifin Corporation**  
Pneumatic Division  
Richland, Michigan  
[www.parker.com/pneumatics](http://www.parker.com/pneumatics)

**Basic Cylinder**



Bore (mm)	A	B	C	DB	DC	DD	E	F	G	HA	HB	HC	J	K	L	LL	LA	M	N
25	2.09 (53)	0.67 (17)	2.09 (53)	0.79 (20)	1.02 (26)	0.75 (19)	0.55 (14)	0.39 (10)	1.59 (40.5)	0.30 (7.5)	0.79 (20)	0.74 (18.9)	0.95 (24)	2.80 (71)	7.48 (190)	7.56 (192)	0.08 (2)	1/4-20 (M6)	0.35 (9)
32	2.60 (66)	0.73 (18.5)	2.24 (57)	1.26 (32)	1.06 (27)	0.83 (21)	0.59 (15)	0.51 (13)	1.71 (43.5)	0.39 (10)	0.93 (23.5)	0.85 (21.5)	1.10 (28)	3.35 (85)	8.90 (226)	9.00 (228.5)	0.10 (2.5)	1/4-20 (M6)	0.35 (9)
40	3.15 (80)	0.87 (22)	2.64 (67)	1.42 (36)	1.38 (35)	1.10 (28)	0.67 (17)	0.55 (14)	2.03 (51.5)	0.51 (13)	1.02 (26)	1.06 (27)	1.22 (31)	3.58 (91)	9.61 (244)	9.71 (246.5)	0.10 (2.5)	5/16-18 (M8)	0.47 (12)
50	3.78 (96)	1.10 (28)	3.23 (82)	1.77 (45)	1.38 (35)	1.38 (35)	0.91 (23)	0.63 (16)	2.40 (61)	0.59 (15)	1.30 (33)	1.39 (35.3)	1.54 (39)	3.54 (90)	10.16 (258)	10.26 (260.5)	0.10 (2.5)	5/16-18 (M8)	0.47 (12)
63	4.65 (118)	1.38 (35)	3.74 (95)	1.97 (50)	1.54 (39)	1.65 (42)	0.75 (19)	0.79 (20)	2.91 (74)	0.59 (15)	1.26 (32)	1.69 (43)	1.54 (39)	4.29 (109)	11.65 (296)	11.75 (298.5)	0.10 (2.5)	3/8-16 (M10)	0.59 (15)

Bore (mm)	P	Q	TA	TB	TC	TD	TE	TL	XA	XB	XC	XE
25	6.38 (162)	1/8 NPT (1/8 Rc)	4.80 (122)	2.76 (70)	1.89 (48)	0.79 (20)	10-24 (M5)	0.32 (8)	1.50 (38)	0.91 (23)	0.22 (5.5)	1.58 (40)
32	7.72 (196)	1/4 NPT (1/4 Rc)	5.28 (134)	3.15 (80)	2.21 (56)	0.79 (20)	1/4-20 (M6)	0.35 (9)	1.89 (48)	0.98 (25)	0.24 (6)	1.85 (47)
40	8.27 (210)	1/4 NPT (1/4 Rc)	5.83 (148)	3.54 (90)	2.68 (68)	1.18 (30)	1/4-20 (M6)	0.43 (11)	2.36 (60)	1.18 (30)	0.28 (7)	2.28 (58)
50	8.35 (212)	3/8 NPT (3/8 Rc)	5.98 (152)	3.94 (100)	3.15 (80)	1.18 (30)	5/16-18 (M8)	0.51 (13)	2.91 (74)	1.42 (36)	0.39 (10)	2.76 (70)
63	10.16 (258)	3/8 NPT (3/8 Rc)	6.61 (168)	4.33 (110)	4.02 (102)	1.58 (40)	5/16-18 (M8)	0.51 (13)	3.78 (96)	1.65 (42)	0.55 (14)	3.54 (90)

inches (mm)

**G**  
 Rodless Pneumatic Cylinders  
 OSP-P Series  
 P1X Series  
 P1Z Series  
 GDL Series



For inventory, lead times, and kit lookup, visit [www.pdnplu.com](http://www.pdnplu.com)

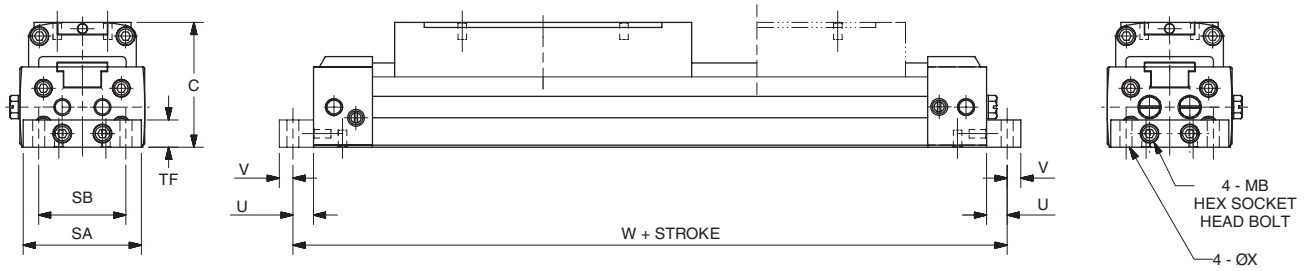
G106

**Parker Hannifin Corporation**  
 Pneumatic Division  
 Richland, Michigan  
[www.parker.com/pneumatics](http://www.parker.com/pneumatics)

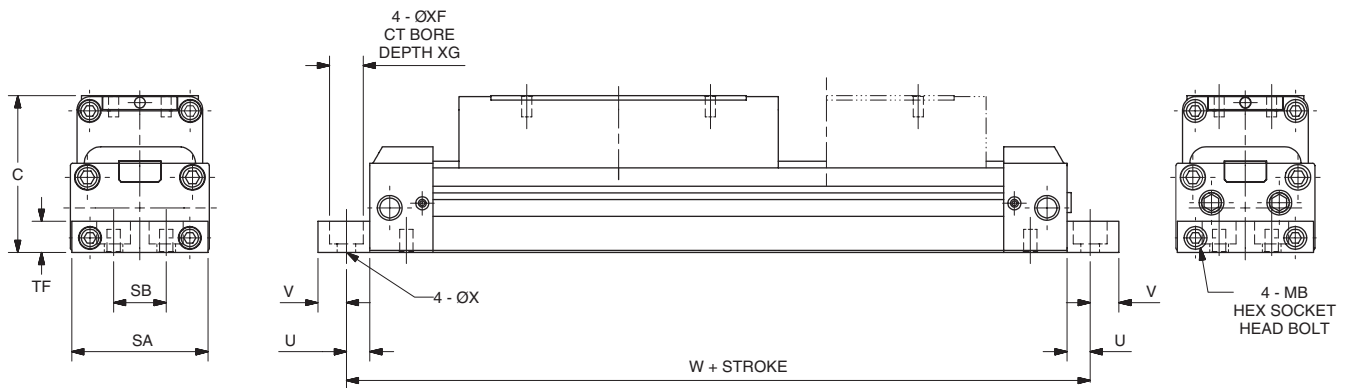


**End Mount Foot Bracket**

16 to 32 mm bore sizes



40 to 63 mm bore sizes



Bore (mm)	C	SA	SB	TF	U	V	W	X	XF	XG	MB
16	1.46 (37)	1.38 (35)	1.02 (26)	0.32 (8)	0.24 (6)	0.16 (4)	6.34 (161)	0.14 (3.6)	—	—	M3x10
20	1.65 (42)	1.69 (43)	1.30 (33)	0.39 (10)	0.24 (6)	0.24 (6)	7.13 (181)	0.19 (4.7)	—	—	M4x12
25	2.09 (53)	2.05 (52)	0.79 (20)	0.47 (12)	0.35 (9)	0.43 (11)	8.19 (208)	0.28 (7)	—	—	M5x50
32	2.24 (57)	2.52 (64)	1.26 (32)	0.47 (12)	0.35 (9)	0.43 (11)	9.61 (244)	0.28 (7)	—	—	M5x50
40	2.64 (67)	3.15 (80)	1.18 (30)	0.59 (15)	0.49 (12.5)	0.45 (11.5)	10.60 (269)	0.35 (9)	0.51 (13)	0.34 (8.7)	M6x55
50	3.23 (82)	3.70 (94)	1.57 (40)	0.79 (20)	0.49 (12.5)	0.45 (11.5)	11.10 (283)	0.35 (9)	0.51 (13)	0.34 (8.7)	M8x65
63	3.74 (95)	4.57 (116)	1.89 (48)	0.98 (25)	0.59 (15)	0.59 (15)	12.80 (326)	0.43 (11)	0.61 (15.5)	0.41 (10.5)	M8x70

inches (mm)



Rodless Pneumatic Cylinders

OSP-P Series

P1X Series

P1Z Series

GDL Series



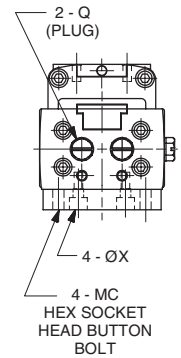
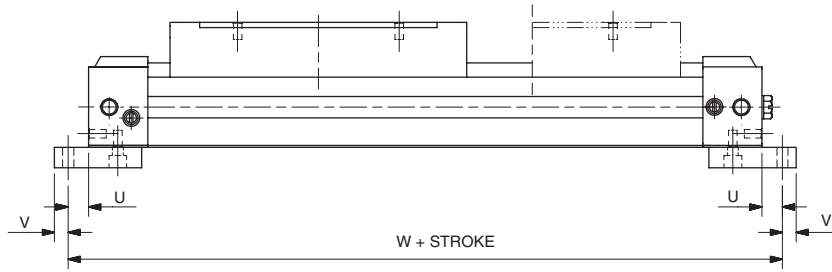
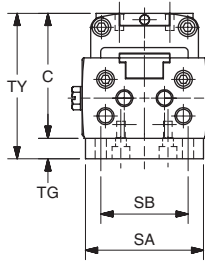
For inventory, lead time, and kit lookup, visit [www.pdnplu.com](http://www.pdnplu.com)

G107

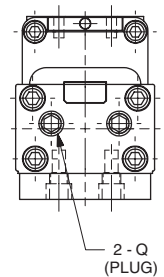
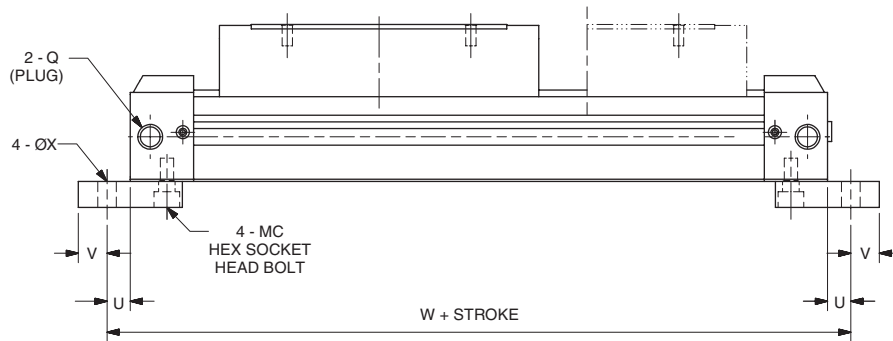
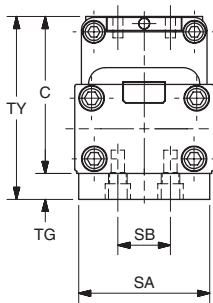
**Parker Hannifin Corporation**  
Pneumatic Division  
Richland, Michigan  
[www.parker.com/pneumatics](http://www.parker.com/pneumatics)

**Bottom Mount Foot Bracket**

16 to 20 mm bore sizes



25 to 32 mm bore sizes



Bore (mm)	C	Q	SA	SB	TG	TY	U	V	W	X	MC
16	1.46 (37)	10-32 (M5)	1.38 (35)	1.02 (26)	0.24 (6)	1.69 (43)	0.24 (6)	0.16 (4)	6.34 (161)	0.13 (3.4)	5-40, 1/4 LG
20	1.65 (42)	1/8 NPT (1/8 Rc)	1.69 (43)	1.30 (33)	0.32 (8)	1.97 (50)	0.24 (6)	0.24 (6)	7.13 (181)	0.18 (4.5)	8-32, 3/8 LG
25	2.09 (53)	1/8 NPT (1/8 Rc)	1.97 (50)	0.79 (20)	0.39 (10)	2.48 (63)	0.35 (9)	0.43 (11)	8.19 (208)	0.28 (7)	1/4-20 x 1/2 LG
32	2.24 (57)	1/4 NPT (1/4 Rc)	2.52 (64)	1.26 (32)	0.39 (10)	2.64 (67)	0.35 (9)	0.43 (11)	9.61 (244)	0.28 (7)	1/4-20 x 1/2 LG
40	2.64 (67)	1/4 NPT (1/4 Rc)	—	—	—	—	—	—	—	—	—
50	3.23 (82)	3/8 NPT (3/8 Rc)	—	—	—	—	—	—	—	—	—
63	3.74 (95)	3/8 NPT (3/8 Rc)	—	—	—	—	—	—	—	—	—

inches (mm)

**G**  
 Rodless Pneumatic Cylinders  
 OSP-P Series  
 P1X Series  
 P1Z Series  
 GDL Series



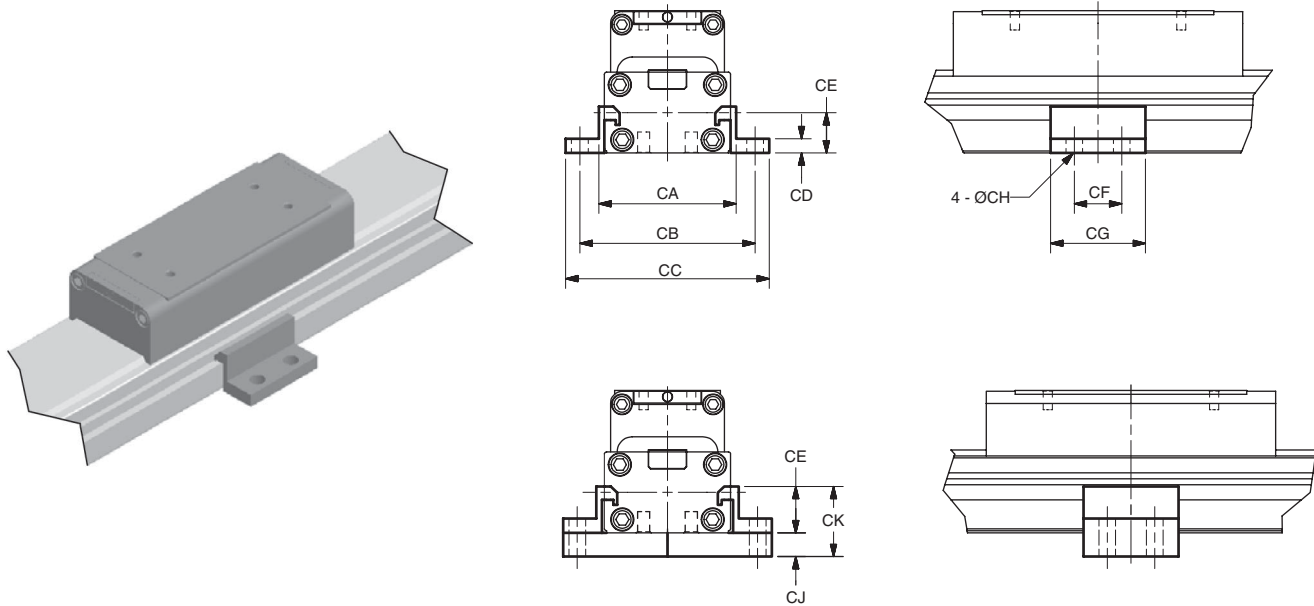
For inventory, lead times, and kit lookup, visit [www.pdnplu.com](http://www.pdnplu.com)

G108

**Parker Hannifin Corporation**  
 Pneumatic Division  
 Richland, Michigan  
[www.parker.com/pneumatics](http://www.parker.com/pneumatics)

**Intermediate support brackets (2 per kit)**

**End mount**



Bore (mm)	CA	CB	CC	CD	CE	CF	CG	CH
16	1.654 (42)	2.205 (56)	2.52 (64)	0.118 (3)	0.472 (12)	0.787 (20)	1.378 (35)	0.157 (4)
20	1.929 (49)	2.52 (64)	2.953 (75)	0.157 (4)	0.551 (14)	0.787 (20)	1.496 (38)	0.197 (5)
25	2.362 (60)	2.992 (76)	3.465 (88)	0.236 (6)	0.768 (19.5)	0.787 (20)	1.575 (40)	0.276 (7)
32	2.913 (74)	3.465 (88)	3.937 (100)	0.236 (6)	0.846 (21.5)	0.787 (20)	1.575 (40)	0.276 (7)
40	3.543 (90)	4.252 (108)	4.882 (124)	0.236 (6)	0.965 (24.5)	1.181 (30)	2.362 (60)	0.354 (9)
50	4.173 (106)	4.882 (124)	5.512 (140)	0.315 (8)	1.201 (30.5)	1.181 (30)	2.362 (60)	0.354 (9)
63	5.118 (130)	5.984 (152)	6.772 (172)	0.394 (10)	1.516 (38.5)	1.969 (50)	3.543 (90)	0.433 (11)

Bore (mm)	CJ	CK	Kit part number	
			End mount or no mount	Bottom mount
16	0.236 (6)	0.709 (18)	<b>L080180016</b>	<b>L080190016</b>
20	0.315 (8)	0.866 (22)	<b>L080180020</b>	<b>L080190020</b>
25	0.394 (10)	1.161 (29.5)	<b>L080180025</b>	<b>L080190025</b>
32	0.394 (10)	1.24 (31.5)	<b>L080180032</b>	<b>L080190032</b>
40	—	—	<b>L080180040</b>	
50	—	—	<b>L080180050</b>	
63	—	—	<b>L080180063</b>	

inches (mm)

**G**

**Rodless Pneumatic Cylinders**

OSP-P Series

P1X Series

P1Z Series

GDL Series



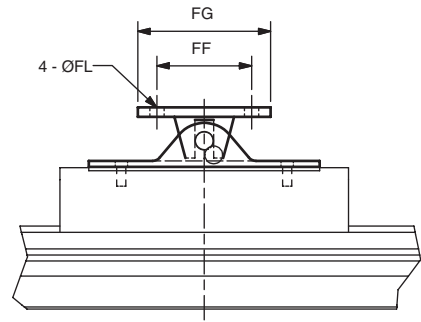
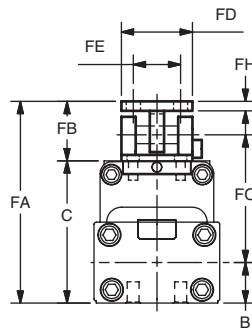
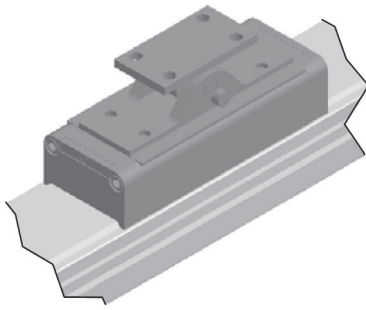
For inventory, lead time, and kit lookup, visit [www.pdnplu.com](http://www.pdnplu.com)

G109

**Parker Hannifin Corporation**  
 Pneumatic Division  
 Richland, Michigan  
[www.parker.com/pneumatics](http://www.parker.com/pneumatics)

**Swivel mount**

Absorbs misalignment between cylinder and load



FJ dimension is the maximum horizontal float

FK dimension is the maximum vertical float

Bore (mm)	FA	FB	FC	FD	FE	FF	FG	FH
16	2.238 (58)	0.827 (21)	1.339 (34)	0.945 (24)	0.673 (16)	1.181 (30)	1.575 (40)	0.118 (3)
20	2.638 (67)	0.984 (25)	1.535 (39)	1.181 (30)	0.787 (20)	1.575 (40)	2.205 (56)	0.157 (4)
25	3.071 (78)	0.984 (25)	1.85 (47)	1.181 (30)	0.787 (20)	1.575 (40)	2.205 (56)	0.157 (4)
32	3.74 (95)	1.496 (38)	2.185 (55.5)	1.772 (45)	1.181 (30)	1.969 (50)	2.756 (70)	0.236 (6)
40	4.134 (105)	1.496 (38)	2.441 (62)	1.772 (45)	1.181 (30)	1.969 (50)	2.756 (70)	0.236 (6)
50	4.961 (126)	1.732 (44)	2.874 (73)	2.362 (60)	1.575 (40)	2.756 (70)	3.543 (90)	0.315 (8)
63	5.472 (139)	1.732 (44)	3.11 (79)	2.362 (60)	1.575 (40)	2.756 (70)	3.543 (90)	0.315 (8)

Bore (mm)		FJ	FK	FL	B	C	Part number
16	inches	0.118	0.118	0.134	0.472	1.457	<b>L078930016</b>
	mm	3	3	3.4	12	37	<b>L078930016</b>
20	inches	0.118	0.118	0.177	0.551	1.654	<b>L080160020</b>
	mm	3	3	4.5	14	42	<b>L08016M020</b>
25	inches	0.118	0.118	0.236	0.669	2.087	<b>L080160025</b>
	mm	3	3	6	17	53	<b>L08016M025</b>
32	inches	0.197	0.197	0.276	0.728	2.244	<b>L080160032</b>
	mm	5	5	7	18.5	57	<b>L08016M032</b>
40	inches	0.197	0.197	0.276	0.866	2.638	<b>L080160040</b>
	mm	5	5	7	22	67	<b>L08016M040</b>
50	inches	0.197	0.197	0.354	1.102	3.228	<b>L080160050</b>
	mm	5	5	9	28	82	<b>L08016M050</b>
63	inches	0.197	0.197	0.354	1.378	3.74	<b>L080160063</b>
	mm	5	5	9	35	95	<b>L08016M063</b>

inches (mm)

**G**  
 Rodless Pneumatic Cylinders  
 OSP-P Series  
 P1X Series  
 P1Z Series  
 GDL Series



For inventory, lead times, and kit lookup, visit [www.pdnplu.com](http://www.pdnplu.com)

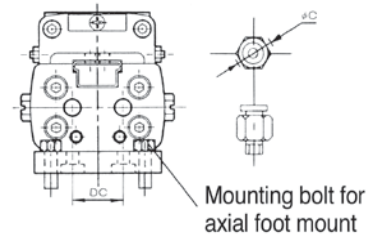
G110

**Parker Hannifin Corporation**  
 Pneumatic Division  
 Richland, Michigan  
[www.parker.com/pneumatics](http://www.parker.com/pneumatics)

**End Port Piping**

Refer to chart below to determine when end port piping can be used with various types of mountings relative to fitting clearance.

On all bore sizes with foot mounting, the end port pipe fittings will obstruct the mounting holes. To avoid this problem, mount the cylinder first and tighten the mounting bolts and then attach the pipe fittings to the cylinder ports.



Bore (mm)	øC [O.D. of fittings - mm (in.)]		
	No mount	End mount	Bottom mount
16	12 (0.472)		12 (0.472)
20	16 (0.630)	End Port Piping	16 (0.630)
25	26 (1.024)	Not Available	26 (1.024)
32	27 (1.065)		27 (1.063)
40	35 (1.378)	26 (1.024)	
50	35 (1.378)	30 (1.181)	
63	39 (1.535)	34 (1.339)	



Rodless Pneumatic Cylinders

OSP-P Series

P1X Series

P1Z Series

GDL Series



For inventory, lead time, and kit lookup, visit [www.pdnplu.com](http://www.pdnplu.com)

G111

**Parker Hannifin Corporation**  
Pneumatic Division  
Richland, Michigan  
[www.parker.com/pneumatics](http://www.parker.com/pneumatics)

## Shock Absorbers Selection Criteria

### The Shock Absorber Advantage

- Increase equipment throughput
- Smoother deceleration of loads
- Adjustable end of stroke positioning
- Prevents impact damage
- Minimize shock loads on equipment
- Improves product performance

### Four Steps to Great Performance

#### Step 1. Gather the Application Parameters

- Total load weight (pounds)
- Final velocity at impact (inches/second)\*
- Cycle rate (cycles per hour)

#### Step 2. Verify Shock Absorber Performance

- See charts on the following pages
- Determine that shock absorber will do the job

#### Step 3. Verify the Cycle Rate

- See shock specifications below and verify application is within cycle rate

#### Step 4. Choose the Appropriate Option in Model Code

\*If final velocity cannot be easily calculated, double the average velocity.

### Shock absorber specifications

Cylinder	16mm	20mm	25mm	32mm	40mm	50, 63mm
Shock absorber number	<b>0887790016</b>	<b>0887790020</b>	<b>0887790025</b>	<b>0887790032</b>	<b>0887790040</b>	<b>0887790050</b>
Max. energy absorption - in-lbs (kgf-m)	26.0 (0.3)	60.8 (0.7)	104.2 (1.2)	226 (2.6)	608 (7.0)	1042 (12)
Stroke - inches	0.236	0.315	0.394	0.590	0.787	0.984
Energy absorption / hour - in.-lbs / hour	54,700	109,380	187,510	338,560	729,200	750,000
Max. impact velocity - in. / sec.	59	59	78.7	78.7	98.4	118.1
Max. cycle rate per hour	2100	1800	1800	1500	1200	720
Ambient temperature - °F (°C)	41-140 (5-60)					
Spring return force - lb. Extended	0.65	0.45	0.65	1.33	2.20	3.60
Compressed	1.01	0.97	1.33	2.65	4.86	7.49
Return time - Sec.	0.3	0.3	0.3	0.3	0.4	0.4

**G**  
**Rodless Pneumatic Cylinders**  
**OSP-P Series**  
**P1X Series**  
**P1Z Series**  
**GDL Series**



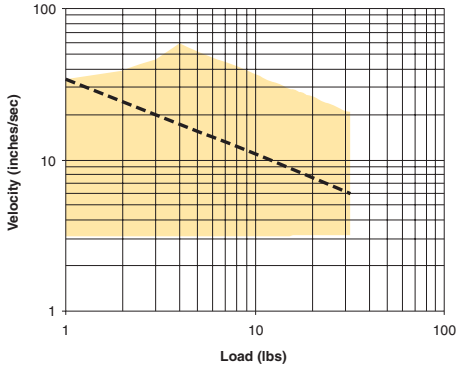
For inventory, lead times, and kit lookup, visit [www.pdnplu.com](http://www.pdnplu.com)

G112

**Parker Hannifin Corporation**  
 Pneumatic Division  
 Richland, Michigan  
[www.parker.com/pneumatics](http://www.parker.com/pneumatics)

**Performance data (16 to 32mm bores)**

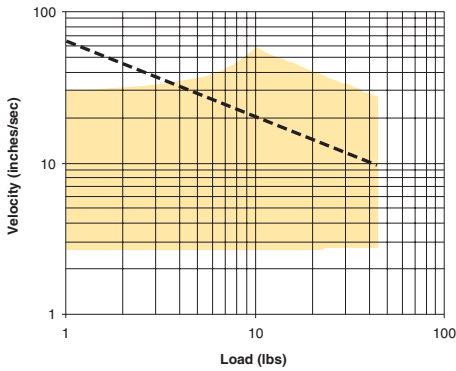
**16 mm Bore**



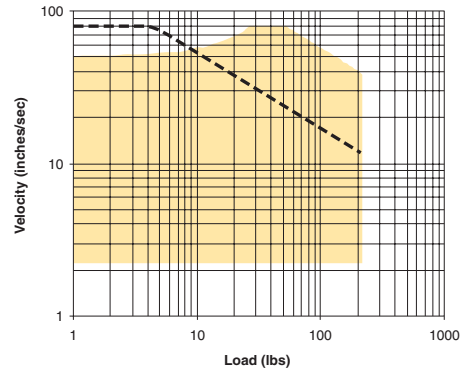
--- Air Cushion w/back pressure (flow controls or other meter out device)  
 Shock Absorber

- Notes:**
1. If the cylinder is vertical in orientation, double the total load for bottom shock absorber.
  2. Use the total load that is being moved by shock absorber. In a weight transfer application, this would include  $L_a$ .
  3. If final velocity cannot be easily determined, use two times the stroke divided by the stroke time.

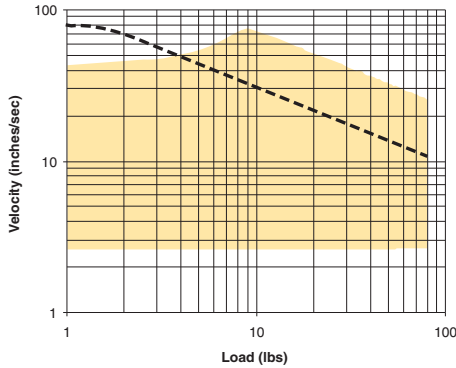
**20 mm Bore**



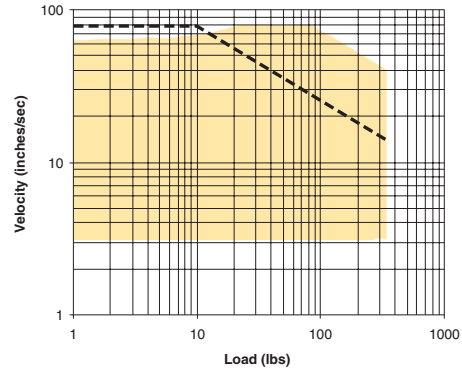
**40 mm Bore**



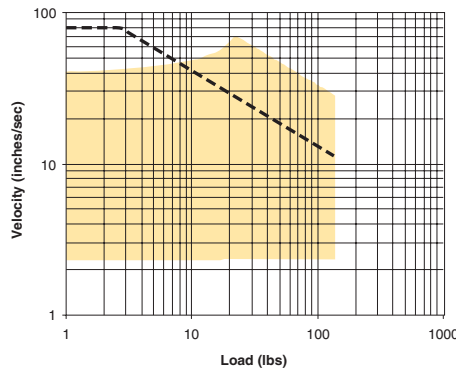
**25 mm Bore**



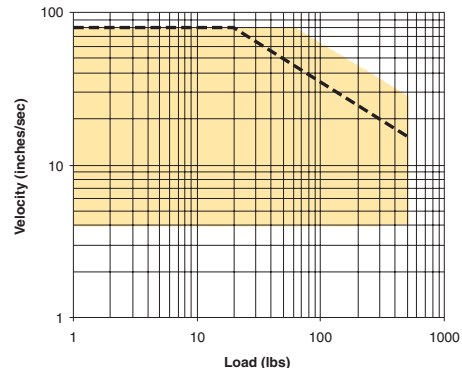
**50 mm Bore**



**32 mm Bore**



**63 mm Bore**



Rodless Pneumatic Cylinders

OSP-P Series

P1X Series

P1Z Series

GDL Series

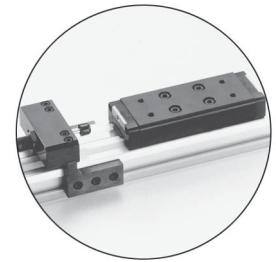


For inventory, lead time, and kit lookup, visit [www.pdnplu.com](http://www.pdnplu.com)

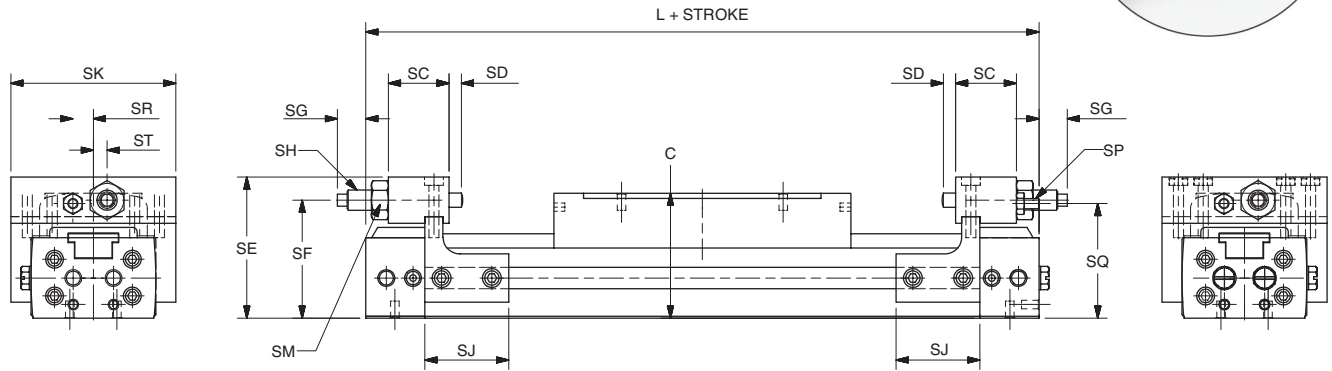
G113

**Parker Hannifin Corporation**  
 Pneumatic Division  
 Richland, Michigan  
[www.parker.com/pneumatics](http://www.parker.com/pneumatics)

**Stroke Adjustments and Shock Absorber Dimensions**



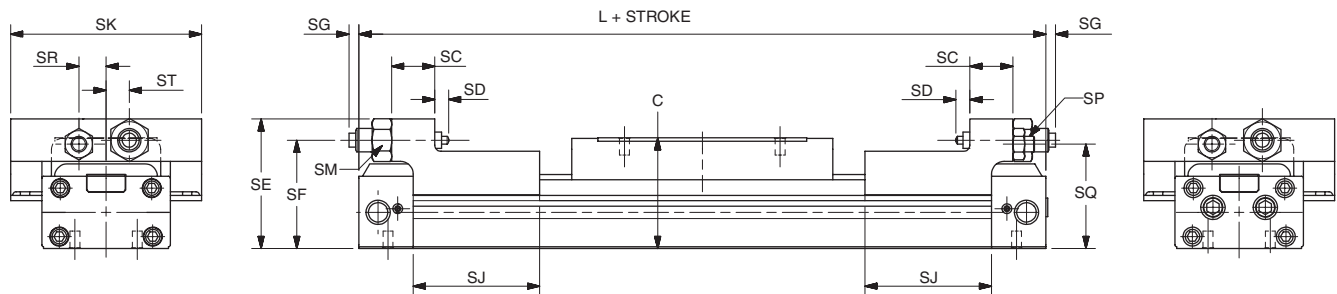
**16 to 25mm bore sizes**



Bore (mm)	SC	SD	SE	SF	SG		SH in-lbs	SJ	SK	SP	SQ	SR	ST	C	L
					Max	Min									
16	0.71 (18)	0.16 (4)	1.65 (42)	1.38 (35)	0.57 (14.5)	0.18 (4.5)	26	0.98 (25)	1.93 (49)	M3	1.34 (34)	0.24 (6)	0.16 (4)	1.46 (37)	5.87 (149)
20	0.89 (22.5)	0.14 (3.5)	1.89 (48)	1.57 (40)	0.57 (14.5)	0.18 (4.5)	61	1.54 (39)	2.24 (57)	M4	1.50 (38)	0.32 (8)	0.20 (5)	1.65 (42)	6.65 (169)
25	0.79 (20)	0.10 (2.5)	2.46 (62.5)	2.03 (51.5)	0.57 (14.5)	0.18 (4.5)	104	1.97 (50)	3.03 (77)	M6	1.97 (50)	0.47 (12)	0.39 (10)	2.09 (53)	7.48 (190)

inches (mm)  
 SH = max. energy absorption

**32 to 63mm bore sizes**



Bore (mm)	SC	SD	SE	SF	SG		SH in-lbs	SJ	SK	SP	SQ	SR	ST	C	L
					Max	Min									
32	0.87 (22)	0.28 (7)	2.62 (66.5)	2.19 (55.5)	1.06 (27)	0.67 (17)	226	2.56 (65)	3.86 (98)	M8	2.11 (53.5)	0.55 (14)	0.47 (12)	2.24 (57)	8.90 (226)
40	1.26 (32)	0.28 (7)	3.09 (78.5)	2.58 (65.5)	1.34 (34)	0.94 (24)	608	2.56 (65)	4.41 (112)	M10	2.50 (63.5)	0.67 (17)	0.47 (12)	2.64 (67)	9.61 (244)
50	1.50 (38)	0.32 (8)	3.90 (99)	3.15 (80)	2.17 (55)	1.77 (45)	1042	2.76 (70)	5.35 (136)	M12	3.05 (77.5)	0.87 (22)	0.67 (17)	3.23 (82)	10.16 (258)
63	1.50 (38)	0.32 (8)	4.41 (112)	3.68 (93.5)	1.73 (44)	1.34 (34)	1042	2.76 (70)	6.22 (158)	M16	3.50 (89)	0.98 (25)	0.79 (20)	3.74 (95)	11.65 (296)

inches (mm)  
 SH = max. energy absorption

**G**  
 Rodless Pneumatic Cylinders  
 OSP-P Series  
 P1X Series  
 P1Z Series  
 GD L Series



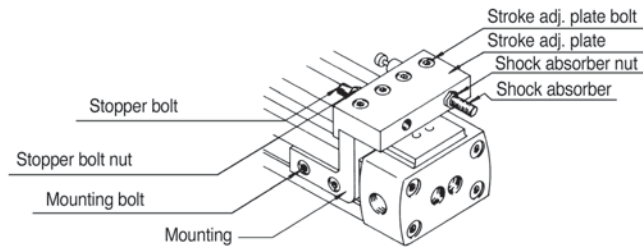
For inventory, lead times, and kit lookup, visit [www.pdnplu.com](http://www.pdnplu.com)

G114

**Parker Hannifin Corporation**  
 Pneumatic Division  
 Richland, Michigan  
[www.parker.com/pneumatics](http://www.parker.com/pneumatics)



**Positioning of stroke adjustment unit**



**ø16-ø25**

- (1) Moving the stroke adjustment unit.  
 The stroke adjustment unit can be moved by loosening the mounting bolts.
- (2) Locking of stroke adjustment unit.  
 After moving the stroke adjustment unit to the appropriate position, lock it there by tightening the mounting bolts to the torque values shown in Figure 1. Insufficient torque may cause the stroke adjustment unit to slip out of position.

**Figure 1**

**Torque values for tightening stroke adjustment unit.**

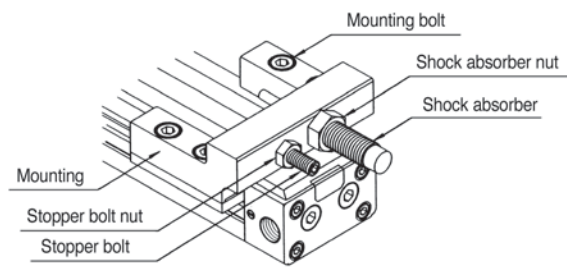
Bore size	Tightening torque	
	Mounting bolt (lb-in)	Stroke adj. plate bolt (lb-in)
16mm	9-11	4-6
20mm	22-24	
25mm	46-50	22-24
32mm	195-213	-
40mm	390-415	-
50, 63mm	682-735	-

- (3) Stroke adjustment using the stopper bolt.  
 Adjust the stroke by loosening the stopper bolt nut and turning the stopper bolt. After adjusting the stroke, tighten the stopper bolt nut to the torque values shown in Figure 2. When adjusting the 16-25 mm cylinders, due to the small amount of clearance between the table and the stroke adjustment plate, adjust the stroke by moving the complete stroke adjustment unit.

**Figure 2**

**Torque values for tightening stopper bolt nut and shock absorber nut.**

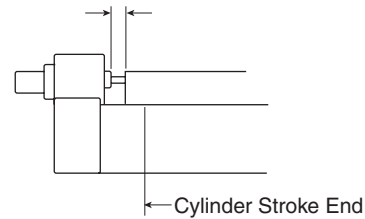
Bore size	Tightening torque	
	Stopper bolt nut (lb-in)	Shock absorber nut (lb-in)
16mm	10-11	12-16
20mm	22-24	26-35
25mm	73-84	40-53
32mm	195-213	66-89
40mm	390-425	195-266
50mm	682-735	487-620
63mm	1772-1914	487-620



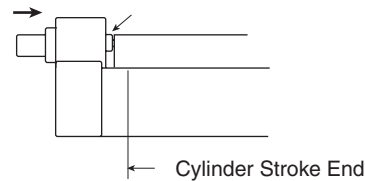
**ø32-ø63**

- (4) Adjustment of shock absorber.  
 Adjust the absorption energy of the shock absorber by changing the operating stroke of the shock absorber. This is done by loosening the shock absorber nut and turning the unit. When adjustment is complete, tighten the shock absorber nut to the torque values shown in Figure 2.
- (5) Notes on usage.  
 The shock absorber absorbs rated energy with rated stroke. The factory setting allows a small amount of shock absorber stroke before it bottoms out. Readjust the location of the shock absorber so that the complete stroke of the absorber is utilized.

Absorption energy as set at factory:  
 Small margin with stroke of shock absorber.



Adjust the position of the shock absorber until the plunger of the shock absorber is fully depressed.



**P1Z Series**

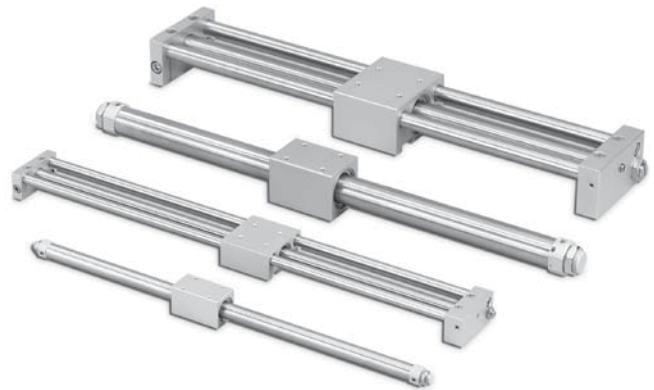
**Basic Version**

The magnetic rodless cylinder is a pneumatic cylinder featuring a mobile piston fitted with annular magnets.

The mobile carriage is also equipped with magnets to provide magnetic coupling between the piston and carriage.

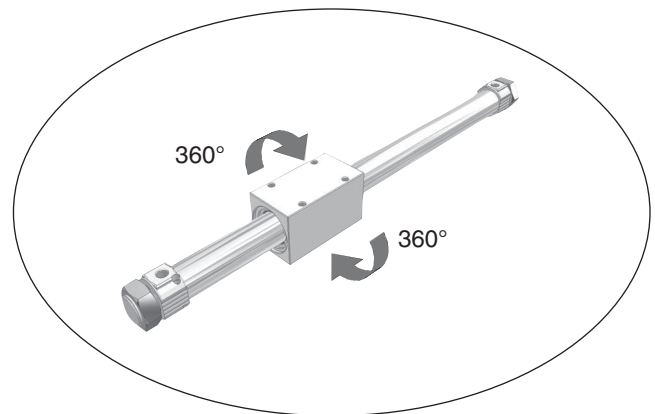
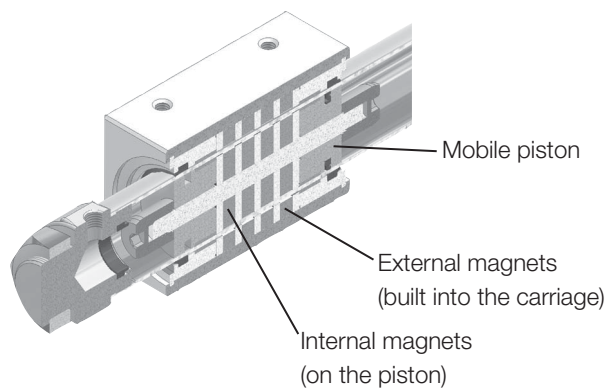
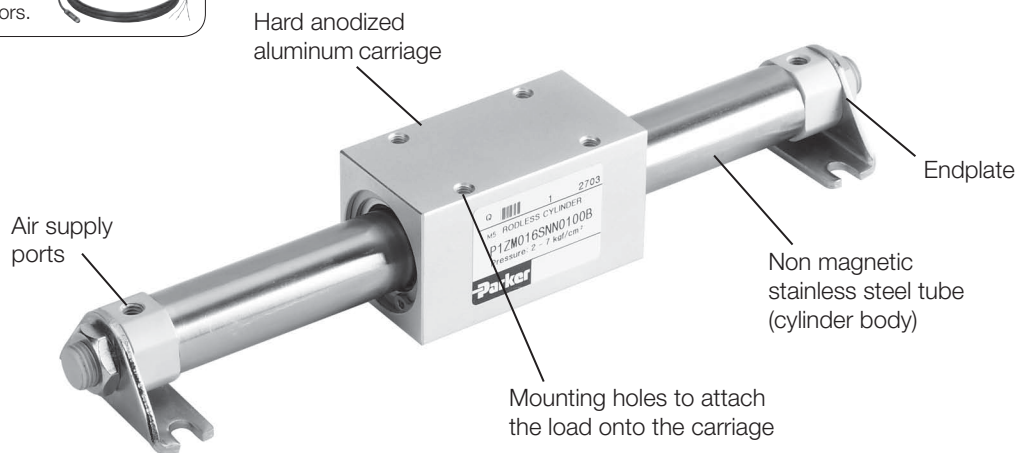
It incorporates the following features:

- End of stroke cushioning/bumpers
- Mounting:
  - threaded endcaps
  - optional foot mount
  - optional flange mount



**Sensors**

See section L for sensors.



**Cushioning**

Ø 16 mm: non-adjustable bumper or adjustable pneumatic cushioning

Ø 20 and 32 mm: adjustable pneumatic cushioning

**Mounting**

The mobile carriage is free to rotate 360° around the cylinder axis. This feature facilitates the adaptation of the cylinder to various mounting arrangements.

The load must be guided by an external device.

<b>G</b>
Rodless Pneumatic Cylinders
OSP-P Series
P1X Series
P1Z Series
GDL Series



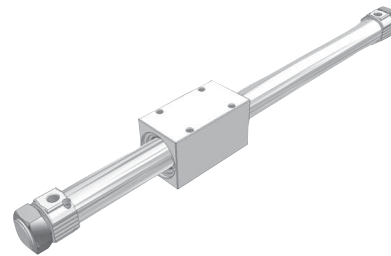
For inventory, lead times, and kit lookup, visit [www.pdnplu.com](http://www.pdnplu.com)

G116

**Parker Hannifin Corporation**  
Pneumatic Division  
Richland, Michigan  
[www.parker.com/pneumatics](http://www.parker.com/pneumatics)

**P1Z Series - Basic Version**

- Available in 3 bores with stroke lengths up to 2000mm
- Adjustable air cushioning is available on all cylinders
- The load is fixed onto the mobile carriage by 4 tapped holes
- The cylinder is attached by the ends with jam nuts, flanges or foot mounts



**Operating information**

Maximum pressure:	100 PSIG (7 bar)
Minimum pressure:	29 PSI (2 bar)
Temperature range:	14°F to 140°F (-10°C to 60°C)

If external lubrication is added, this must always be continued.

**Ordering information**

Standard cylinder (15 positions)						Options (16 positions)																																																		
<b>P</b>	<b>1</b>	<b>Z</b>	<b>M</b>	<b>016</b>	<b>S</b>	<b>N</b>	<b>N</b>	<b>0500</b>	<b>B</b>	<b>F</b>	<b>M</b>	<b>N</b>																																												
			<table border="1" style="font-size: small;"> <tr><th colspan="2">Bore</th></tr> <tr><td><b>016</b></td><td>Ø 16mm</td></tr> <tr><td><b>020</b></td><td>Ø 20mm</td></tr> <tr><td><b>032</b></td><td>Ø 32mm</td></tr> </table>		Bore		<b>016</b>	Ø 16mm	<b>020</b>	Ø 20mm	<b>032</b>	Ø 32mm	<table border="1" style="font-size: small;"> <tr><th colspan="2">Cushioning</th></tr> <tr><td><b>N</b></td><td>None (Ø 16 only)</td></tr> <tr><td><b>A</b></td><td>Adjustable cushions</td></tr> </table>		Cushioning		<b>N</b>	None (Ø 16 only)	<b>A</b>	Adjustable cushions	<table border="1" style="font-size: small;"> <tr><th colspan="2">Strokes</th></tr> <tr><td><b>0200</b></td><td>200mm</td></tr> <tr><td><b>1000</b></td><td>1000mm</td></tr> </table>		Strokes		<b>0200</b>	200mm	<b>1000</b>	1000mm	<table border="1" style="font-size: small;"> <tr><th colspan="2">Options *</th></tr> <tr><td><b>B†</b></td><td>None</td></tr> <tr><td><b>W</b></td><td>With options</td></tr> </table>		Options *		<b>B†</b>	None	<b>W</b>	With options	<table border="1" style="font-size: small;"> <tr><th colspan="2">Mounting kit*</th></tr> <tr><td><b>F</b></td><td>Foot mount</td></tr> <tr><td><b>L</b></td><td>Flanges</td></tr> <tr><td><b>N</b></td><td>None (std.)</td></tr> </table>		Mounting kit*		<b>F</b>	Foot mount	<b>L</b>	Flanges	<b>N</b>	None (std.)	<table border="1" style="font-size: small;"> <tr><th colspan="2">Cylinder port type</th></tr> <tr><td><b>M†</b></td><td>Metric (Ø 16 only)</td></tr> <tr><td><b>B†</b></td><td>BSPP (Ø 20 &amp; 32)</td></tr> <tr><td><b>N</b></td><td>NPTF (Ø 20 &amp; 32)</td></tr> </table>		Cylinder port type		<b>M†</b>	Metric (Ø 16 only)	<b>B†</b>	BSPP (Ø 20 & 32)	<b>N</b>	NPTF (Ø 20 & 32)
Bore																																																								
<b>016</b>	Ø 16mm																																																							
<b>020</b>	Ø 20mm																																																							
<b>032</b>	Ø 32mm																																																							
Cushioning																																																								
<b>N</b>	None (Ø 16 only)																																																							
<b>A</b>	Adjustable cushions																																																							
Strokes																																																								
<b>0200</b>	200mm																																																							
<b>1000</b>	1000mm																																																							
Options *																																																								
<b>B†</b>	None																																																							
<b>W</b>	With options																																																							
Mounting kit*																																																								
<b>F</b>	Foot mount																																																							
<b>L</b>	Flanges																																																							
<b>N</b>	None (std.)																																																							
Cylinder port type																																																								
<b>M†</b>	Metric (Ø 16 only)																																																							
<b>B†</b>	BSPP (Ø 20 & 32)																																																							
<b>N</b>	NPTF (Ø 20 & 32)																																																							
<p>* Cylinders are supplied with mounting nuts fitted on each endplate.</p> <table border="1" style="font-size: x-small; width: 100%;"> <thead> <tr> <th>Ø</th> <th>Stroke (mm)</th> <th>(in)</th> </tr> </thead> <tbody> <tr> <td>16</td> <td>0 to 1000</td> <td>0 to 39.4</td> </tr> <tr> <td>20</td> <td>0 to 1500</td> <td>0 to 59.1</td> </tr> <tr> <td>32</td> <td>0 to 2000</td> <td>0 to 78.7</td> </tr> </tbody> </table>						Ø	Stroke (mm)	(in)	16	0 to 1000	0 to 39.4	20	0 to 1500	0 to 59.1	32	0 to 2000	0 to 78.7	<p>† Standard when "B" option is used.</p>																																						
Ø	Stroke (mm)	(in)																																																						
16	0 to 1000	0 to 39.4																																																						
20	0 to 1500	0 to 59.1																																																						
32	0 to 2000	0 to 78.7																																																						
<p>Part number examples:</p> <ul style="list-style-type: none"> <li>- P1ZM016SNN0100B      Ø 16 mm bore 100mm stroke cylinder supplied with mounting nut on each endplate</li> <li>- P1ZM020SAN1000WFBN    Ø 20 mm bore 1m stroke cylinder with foot mount on each endplate</li> </ul>																																																								

**G**  
Rodless Pneumatic Cylinders  
OSP-P Series  
P1X Series  
P1Z Series  
GDL Series



For inventory, lead time, and kit lookup, visit [www.pdnplu.com](http://www.pdnplu.com)

G117

**Parker Hannifin Corporation**  
Pneumatic Division  
Richland, Michigan  
[www.parker.com/pneumatics](http://www.parker.com/pneumatics)

**Specifications - P1Z (magnetically coupled rodless)**

- Bore size mm (inch nominal): 16 (5/8) 20 (3/4) 32 (1-1/4)
- Port size: M5 BSPP, 10-32 NPT 1/8 BSPP, 1/8 NPT 1/8 BSPP, 1/8 NPT
- Maximum stroke mm (inch): 1000 (39.4) 1500 (59.1) 2000 (78.7)
- Max. coupling force N (lbs): 157 (35) 236 (53) 703 (158)
- Stroke tolerance mm: +1.5/-0 <=1000 +1.5/-0; >1000 +2/-0
- Piston speed m/s (inch/sec): 0.1 to 0.4 (4 to 15.75)
- Cushion: Air cushion standard
- Lubrication: Not required (If you choose to lubricate your system, continuing lubrication will be required.)

**Weights**

Bore size		Weight at zero stroke		Weight per 25mm of stroke	
mm	inch	kg	lbs	kg	lbs
16	5/8	0.28	0.62	0.01	0.02
20	3/4	0.46	1.01	0.02	0.05
32	1-1/4	1.35	2.98	0.04	0.08

**Conditions of Use**

If external lubrication is added, this must always be continued.

**Working medium, air quality**

Working medium: Dry, filtered compressed air to ISO 8573-1 class 3. 4. 3. or better

**Recommended air quality for cylinders**

For best possible service life and trouble-free operation, ISO 8573-1, quality class 3.4.3 should be used. This means 5 µm filter (standard filter), dew point 3°C for indoor operation (a lower dew point should be selected for outdoor operation) and oil concentration 1.0 mg oil/m³, which is what a standard compressor with a standard filter gives.

**ISO 8573-1 Quality Classes**

Quality Class	Max. Pollution		Water	Oil
	particle size (µm)	max. concentration (mg/m³)	max. pressure dew point (°C)	max. concentration (mg/m³)
1	0.1	0.1	-70	0.01
2	1	1	-40	0.1
3	5	5	-20	1.0
4	15	8	+3	5.0
5	40	10	+7	25
6	-	-	+10	-


  
 Rodless Pneumatic Cylinders
   
 OSP-P Series
   
 P1X Series
   
 P1Z Series
   
 GDL Series

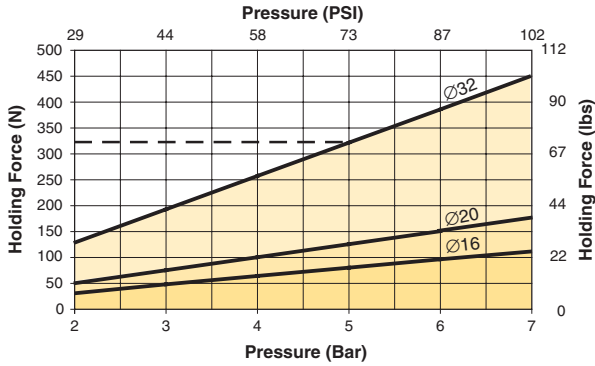


For inventory, lead times, and kit lookup, visit [www.pdnplu.com](http://www.pdnplu.com)

G118

**Parker Hannifin Corporation**  
 Pneumatic Division  
 Richland, Michigan  
[www.parker.com/pneumatics](http://www.parker.com/pneumatics)

**Pressure in the Cylinder / Pneumatic Holding Force**



**Example:**

Pressure: 5 bar

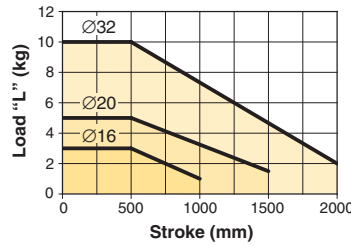
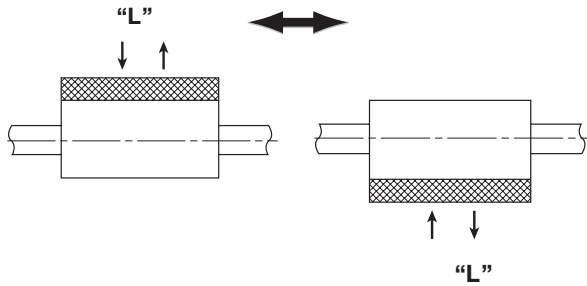
$F_{max} = 322 \text{ N}$  for  $\text{Ø} 32 \text{ mm}$  cylinder

⚠ Calculate the kinetic energy due to the load moved

Acceleration or deceleration should not exceed the magnetic coupling force of cylinder

**Load diagrams**

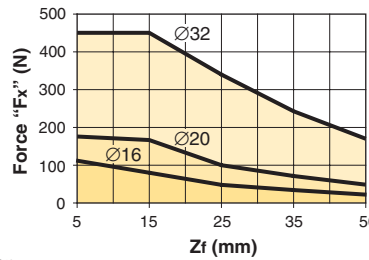
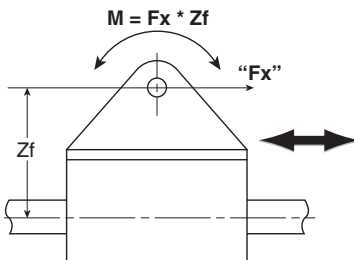
**Permissible radial loads, horizontal mounting**



Ø	L Max. (kg)	(lbs.)
16	3	6.6
20	5	11.0
32	10	22.0

⚠ The load must be guided by a device from outside the cylinder

**Permissible axial loads, horizontal mounting**

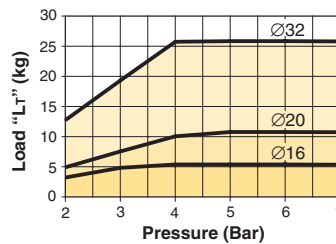
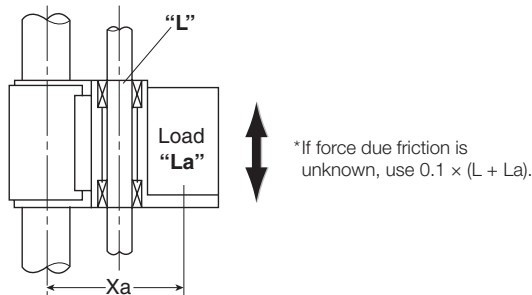


Ø	Max. Moment M		Max. Fx*	
	(Nm)	(in.-lbs.)	(N)	(lbs.)
16	1.2	11	112	25
20	2.5	22	175	39
32	8.5	75	450	101

\* at 7 bar

⚠ The load must be guided by a device from outside the cylinder

**Permissible axial loads, vertical mounting**



Ø	Max. load T		Max. XA	
	(kg)	(lbs.)	(mm)	(in.)
16	5	11	122	4.8
20	10	22	142	5.6
32	24	53	174	6.8

\* at 6.5 bar

**L** = Load guided by external device  
**La** = Direct mounting onto the cylinder  
**Ff** = Force due to friction\*

**LT** = Load weight + guiding device weight + force due to friction



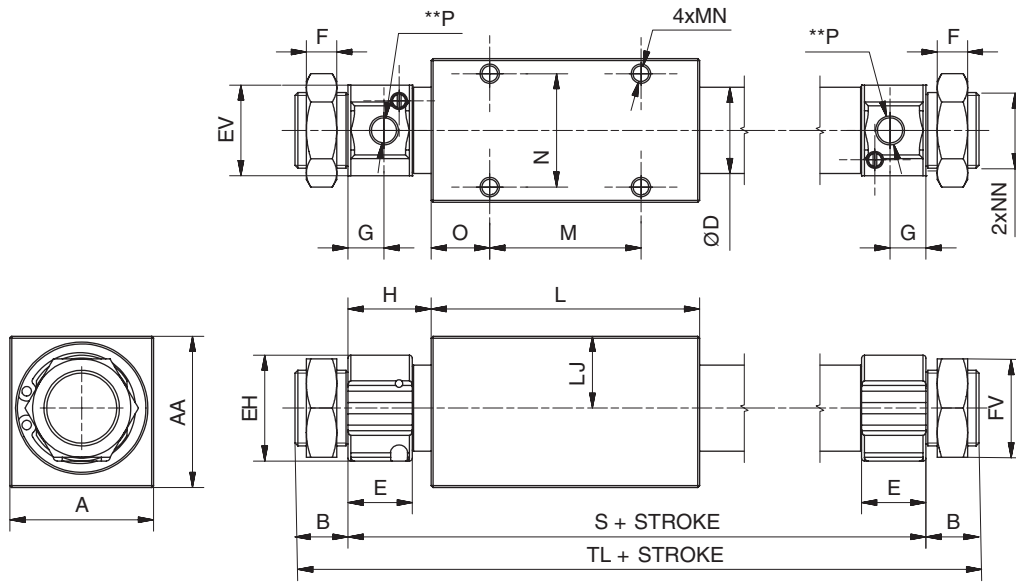
For inventory, lead time, and kit lookup, visit [www.pdnplu.com](http://www.pdnplu.com)

G119

**Parker Hannifin Corporation**  
 Pneumatic Division  
 Richland, Michigan  
[www.parker.com/pneumatics](http://www.parker.com/pneumatics)

**Basic Version**

\*\* = Air supply Ports



Ø	A	AA	B	ØD	E	ØEH	ØEV	F	FV	G	H	L	LJ	M	N	O
16	32 (1.26)	34 (1.34)	10 (0.39)	18 (0.71)	11 (0.43)	18 (0.71)	18 (0.71)	4 (0.16)	14 (0.55)	5.5 (0.22)	15.5 (0.61)	61 (2.40)	16 (0.63)	34 (1.34)	25 (0.98)	13.5 (0.53)
20	38 (1.50)	40 (1.57)	14 (0.55)	22.8 (0.90)	17 (0.67)	28 (1.10)	24 (0.94)	8 (0.31)	26 (1.02)	9.5 (0.37)	22 (0.87)	71 (2.80)	19 (0.75)	40 (1.57)	30 (1.18)	15.5 (0.61)
32	60 (2.36)	60 (2.36)	16 (0.63)	35 (1.38)	17 (0.67)	40 (1.57)	36 (1.42)	8 (0.31)	32 (1.26)	9.5 (0.37)	23 (0.91)	87 (3.43)	30 (1.18)	50 (1.97)	40 (1.57)	18.5 (0.73)

Ø	P	MN	NN	S	TL
16	M5 x 0.8 (10-32)	M4 x 0.7 x 6	M10 x 1 x 6	92 (3.62)	112 (4.41)
20	G 1/8 (1/8)	M5 x 0.8 x 8	M20 x 1.5 x 7	115 (4.53)	143 (5.63)
32	G 1/8 (1/8)	M6 x 1 x 10	M26 x 1.5 x 7	133 (5.24)	165 (6.50)

**G**  
 Rodless Pneumatic  
 Cylinders  
 OSP-P  
 Series  
 P1X  
 Series  
 P1Z  
 Series  
 GDL  
 Series



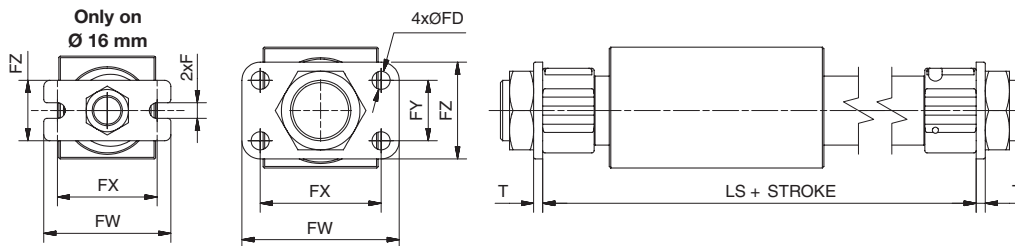
For inventory, lead times, and kit lookup, visit [www.pdnplu.com](http://www.pdnplu.com)

G120

**Parker Hannifin Corporation**  
 Pneumatic Division  
 Richland, Michigan  
[www.parker.com/pneumatics](http://www.parker.com/pneumatics)

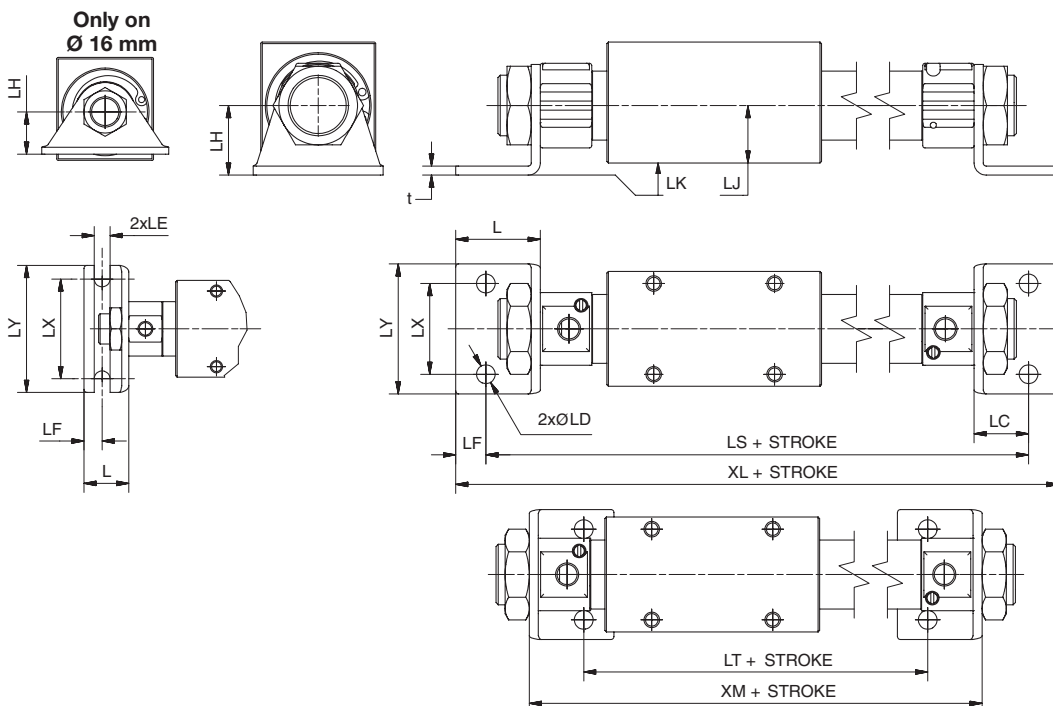
Mountings

Flanges



Ø	F	ØFD	FW	FX	FY	FZ	T	LS	Part number
16	5.2 (0.20)	-	42 (1.65)	33 (1.30)	-	20 (0.79)	2.3 (0.09)	92 (3.62)	<b>PDC15-FH</b>
20	-	6 (0.24)	52 (2.05)	40 (1.57)	20 (0.78)	32 (1.26)	3 (0.12)	115 (4.53)	<b>PK1A20-FH</b>
32	-	7 (0.28)	80 (3.15)	64 (2.52)	28 (1.10)	44 (1.73)	5 (0.20)	133 (5.24)	<b>PK1A25-FH</b>

Brackets



Ø	t	L	LC	ØLD	LE	LF	LH	LJ	LK	LX	LY	LS	LT	XL	XM	Part number
16	2.3 (0.09)	14.8 (0.58)	8.8 (0.35)	-	5.2 (0.20)	6 (0.24)	14 (0.55)	16 (0.63)	-2 (-0.08)	33 (1.30)	42 (1.65)	109.6 (4.32)	79 (3.11)	121.6 (4.79)	96.6 (3.80)	<b>PDC15-LB*</b>
20	3 (0.12)	28 (1.10)	18 (0.71)	6.2 (0.24)	-	10 (0.39)	23 (0.91)	19 (0.75)	4 (0.16)	30 (1.18)	43 (1.69)	151 (5.94)	85 (3.35)	171 (6.73)	121 (4.76)	<b>PK1A20-LB*</b>
32	3 (0.12)	35 (1.38)	23 (0.91)	7 (0.28)	-	12 (0.47)	30 (1.18)	30 (1.18)	0 (0)	46 (1.81)	62 (2.44)	179 (7.05)	**	203 (7.99)	**	<b>PK1A25-LB*</b>

\* Set of 2 pcs

\*\* Impossible mounting

**G**  
 Rodless Pneumatic Cylinders  
 OSP-P Series  
 P1X Series  
 P1Z Series  
 GDL Series



For inventory, lead time, and kit lookup, visit [www.pdnplu.com](http://www.pdnplu.com)

**P1Z Series - Guided Version**

The magnetic rodless cylinder is a pneumatic cylinder featuring a mobile piston with annular magnets.

The mobile carriage is also equipped with magnets to give magnetic coupling between the piston and carriage. The carriage slides along the main tube and is guided by two guide rods.

It incorporates the following features:

- Built-in guide rods
- Adjustable end-of-stroke bumpers
- Optional magnetic piston sensing
- Optional transfer porting

**Guidance**

The guided version consists of a carriage fitted with 4 plain bearings, guided on 2 rods.

This design provides high rigidity, accurate guidance and smooth movement of the carriage.

**End of stroke**

Each endplate can be fitted with an adjustable bumper or self-compensating shock absorbers.

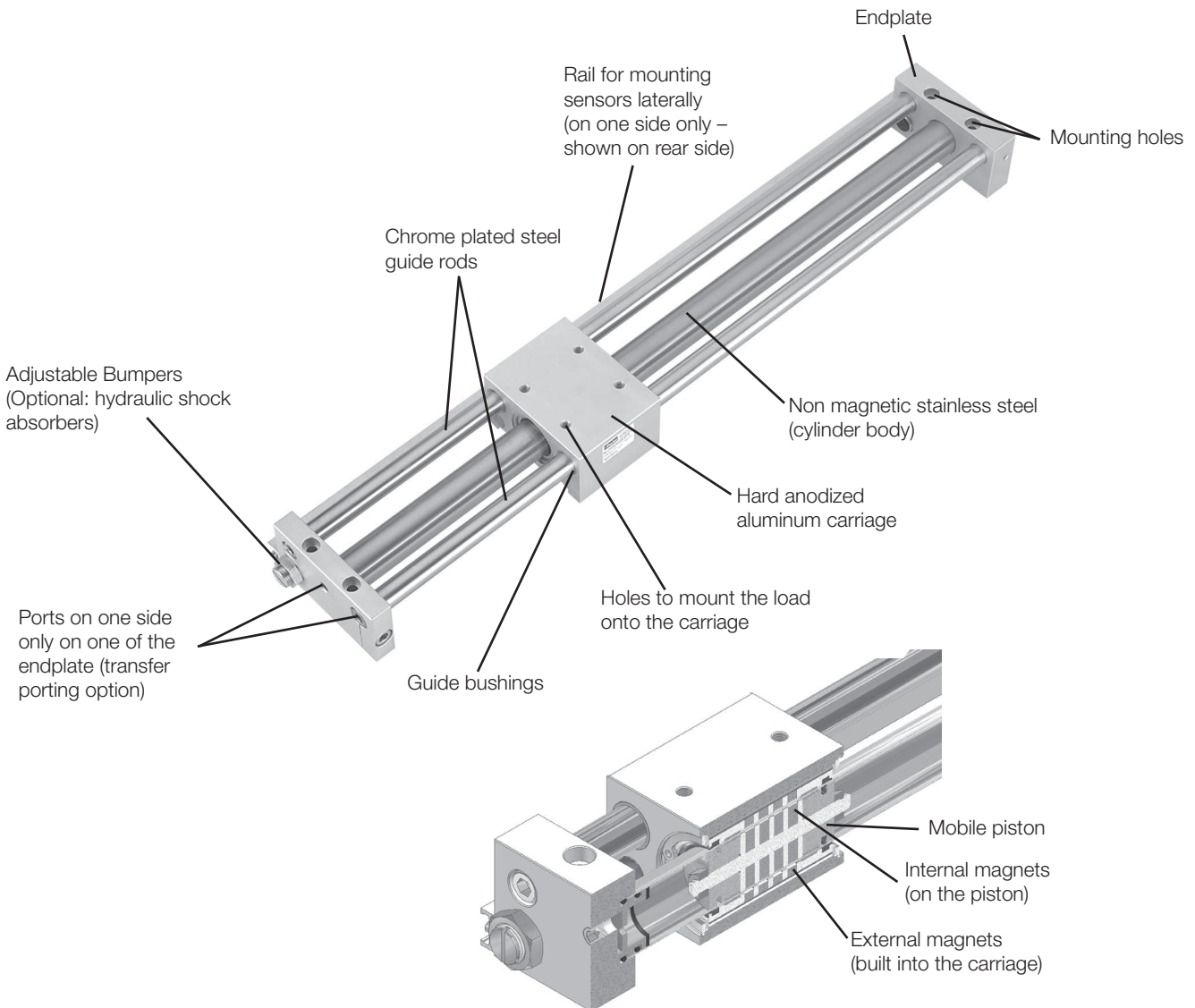
**Optional transfer porting**

Cylinder air supply is located on one end only to facilitate cylinder installation and avoid long tube lengths for longer strokes.

**Options**

The following options are available to enhance the Magnetic Rodless cylinder functions:

- External bumpers: when low operating pressure, light loads and short strokes.
- External hydraulic shock absorbers: recommended for arduous applications.
- Reed and solid state sensors: provide sensing at an adjustable position along the entire stroke of the cylinder.



<b>G</b>
Rodless Pneumatic Cylinders
OSP-P Series
P1X Series
P1Z Series
GDL Series



For inventory, lead times, and kit lookup, visit [www.pdnplu.com](http://www.pdnplu.com)

G122

**Parker Hannifin Corporation**  
Pneumatic Division  
Richland, Michigan  
[www.parker.com/pneumatics](http://www.parker.com/pneumatics)



**Features**

**Rodless Pneumatic Cylinders  
P1Z Series - Guided Version**

**P1Z Series - Guided Version**

**Operating information**

Maximum pressure:	100 PSIG (7 bar)
Minimum pressure:	29 PSI (2 bar)
Temperature range:	14°F to 140°F (-10°C to 60°C)

If external lubrication is added, this must always be continued.



**Ordering information**

Standard cylinder (15 positions)				Options (16 positions)																																				
<b>P</b>	<b>1Z</b>	<b>M</b>	<b>016</b>	<b>T</b>	<b>C</b>	<b>N</b>	<b>0500</b>	<b>B</b>	<b>N</b>	<b>M</b>	<b>L</b>																													
			<table border="1" style="font-size: small;"> <tr><th colspan="2">Bore</th></tr> <tr><td>016</td><td>Ø 16 mm</td></tr> <tr><td>020</td><td>Ø 20 mm</td></tr> <tr><td>032</td><td>Ø 32 mm</td></tr> </table>	Bore		016	Ø 16 mm	020	Ø 20 mm	032	Ø 32 mm	<table border="1" style="font-size: small;"> <tr><th colspan="2">Cushioning</th></tr> <tr><td>C</td><td>Adjustable stop</td></tr> <tr><td>H</td><td>Hydraulic shock absorber</td></tr> </table>		Cushioning		C	Adjustable stop	H	Hydraulic shock absorber			<table border="1" style="font-size: small;"> <tr><th colspan="2">Strokes</th></tr> <tr><td>0200</td><td>200 mm</td></tr> <tr><td>1000</td><td>1000 mm</td></tr> </table>	Strokes		0200	200 mm	1000	1000 mm			<table border="1" style="font-size: small;"> <tr><th colspan="2">Cylinder port type</th></tr> <tr><td>M†</td><td>Metric (Ø 16 only)</td></tr> <tr><td>B†</td><td>BSPP (Ø 20 &amp; 32)</td></tr> <tr><td>N</td><td>NPTF (Ø 20 &amp; 32)</td></tr> </table> <p style="font-size: x-small;">† Standard when "B" option is used.</p>		Cylinder port type		M†	Metric (Ø 16 only)	B†	BSPP (Ø 20 & 32)	N	NPTF (Ø 20 & 32)
Bore																																								
016	Ø 16 mm																																							
020	Ø 20 mm																																							
032	Ø 32 mm																																							
Cushioning																																								
C	Adjustable stop																																							
H	Hydraulic shock absorber																																							
Strokes																																								
0200	200 mm																																							
1000	1000 mm																																							
Cylinder port type																																								
M†	Metric (Ø 16 only)																																							
B†	BSPP (Ø 20 & 32)																																							
N	NPTF (Ø 20 & 32)																																							
				<table border="1" style="font-size: small;"> <tr><th colspan="2">Function</th></tr> <tr><td>G</td><td>Guided</td></tr> <tr><td>T</td><td>Guided with transfer porting</td></tr> </table>		Function		G	Guided	T	Guided with transfer porting	<table border="1" style="font-size: small;"> <tr><th colspan="2">Options</th></tr> <tr><td>B†</td><td>None</td></tr> <tr><td>W</td><td>With options</td></tr> </table>		Options		B†	None	W	With options	<table border="1" style="font-size: small;"> <tr><th colspan="4">End of stroke sensing</th></tr> <tr> <th>NPN</th> <th>PNP</th> <th>Reed</th> <th>Sensors type (Qty: 2)</th> </tr> <tr> <td>L</td> <td></td> <td></td> <td>With rail, no sensor</td> </tr> <tr> <td>N† (std.)</td> <td></td> <td></td> <td>No sensor rail</td> </tr> </table>				End of stroke sensing				NPN	PNP	Reed	Sensors type (Qty: 2)	L			With rail, no sensor	N† (std.)			No sensor rail	
Function																																								
G	Guided																																							
T	Guided with transfer porting																																							
Options																																								
B†	None																																							
W	With options																																							
End of stroke sensing																																								
NPN	PNP	Reed	Sensors type (Qty: 2)																																					
L			With rail, no sensor																																					
N† (std.)			No sensor rail																																					
								<p style="font-size: x-small;"><b>Note:</b> Order Sensors separately.</p>																																
			<table border="1" style="font-size: x-small;"> <tr> <th>Ø</th> <th>Stroke (mm)</th> <th>(in)</th> </tr> <tr> <td>16</td> <td>0 to 750</td> <td>0 to 29.5</td> </tr> <tr> <td>20</td> <td>0 to 1000</td> <td>0 to 39.4</td> </tr> <tr> <td>32</td> <td>0 to 1000</td> <td>0 to 59.1</td> </tr> </table>		Ø	Stroke (mm)	(in)	16	0 to 750	0 to 29.5	20	0 to 1000	0 to 39.4	32	0 to 1000	0 to 59.1	<p style="font-size: x-small;">Part number examples:</p> <p style="font-size: x-small;">- P1ZM016GCN0100B      Ø 16 mm bore 100mm stroke cylinder supplied with adjustable stop</p> <p style="font-size: x-small;">- P1ZM020GHN1000WNBL      Ø 20 mm bore 1m stroke cylinder with hydraulic shock absorbers and rail for sensors</p>																							
Ø	Stroke (mm)	(in)																																						
16	0 to 750	0 to 29.5																																						
20	0 to 1000	0 to 39.4																																						
32	0 to 1000	0 to 59.1																																						

**Range**

**Magnetic rodless cylinder, guided version**

Available in 3 diameters with possible strokes up to 1500 mm (59 in).

4 tapped mounting holes on the carriage.

Endcap mounting provided by 4 tapped and counterbored holes.

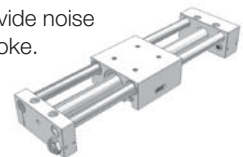


**Options**

**External adjustable bumpers**

Can be fitted on cylinder endcaps and provide noise reduction and adjustment at the end of stroke.

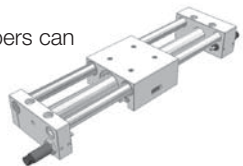
Used when light loads and short strokes. Pneumatic air supply on one side only (transfer porting option).



**External hydraulic shock absorbers**

Self-compensating hydraulic shock absorbers can be used instead of bumpers for a greater cushioning effect at the end of stroke.

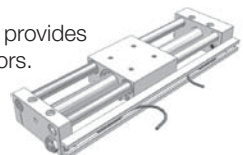
They are recommended for arduous applications.



**Reed or solid state sensors:**

A rail fitted on one side only of the cylinder provides mounting and position adjustment of sensors.

The rail is located on same side as the end of stroke stops.



For inventory, lead time, and kit lookup, visit [www.pdnplu.com](http://www.pdnplu.com)

G123

**Parker Hannifin Corporation**  
Pneumatic Division  
Richland, Michigan  
[www.parker.com/pneumatics](http://www.parker.com/pneumatics)

**Specifications - P1Z (magnetically coupled rodless)**

• Bore size mm (inch nominal):	16 (5/8)	20 (3/4)	32 (1-1/4)
• Port size:	M5 BSPP, 10-32 NPT	1/8 BSPP, 1/8 NPT	1/8 BSPP, 1/8 NPT
• Maximum stroke mm (inch):	750 (29.5)	1000 (39.4)	1500 (59.1)
• Max. coupling force N (lbs):	157 (35)	236 (53)	703 (158)
• Stroke tolerance mm:	+1.5/-0	<=1000 +1.5/-0; >1000 +2/-0	
• Piston speed m/s (inch/sec):	0.1 to 0.4 (4 to 15.75)		
• Cushion:	Air cushion standard		
• Lubrication:	Not required (If you choose to lubricate your system, continuing lubrication will be required.)		

**Weights**

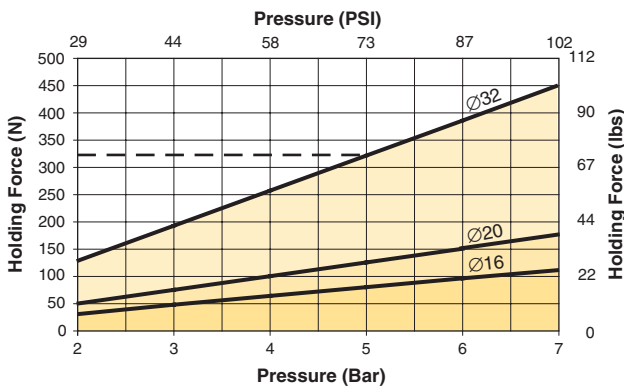
Bore size		Weight at zero stroke		Weight per 25mm of stroke	
mm	inch	kg	lbs	kg	lbs
16	5/8	0.9	1.98	0.05	0.11
20	3/4	1.52	3.35	0.08	0.17
32	1-1/4	3.63	8.00	0.13	0.29

**Options**

Function	Description
Detection	Sensors mounting in T-slot Reed or solid state sensors (PNP or NPN)
External rubber bumpers	Supplied pre-fitted in endplates if chosen
Hydraulic shock absorbers	Self-compensating shock absorbers supplied pre-fitted in endplates if chosen



**Pressure in the Cylinder / Pneumatic Holding Force**



**Example:**

Pressure: 5 bar

$F_{max} = 322 \text{ N}$  for Ø 32 mm cylinder

⚠ Calculate the kinetic energy due to the load moved

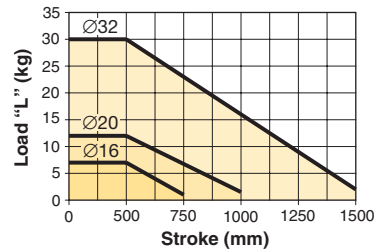
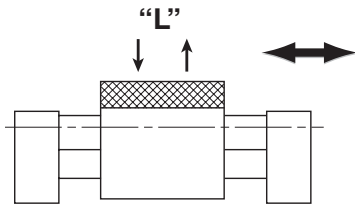
Acceleration or deceleration should not exceed the magnetic coupling force of cylinder



For inventory, lead times, and kit lookup, visit [www.pdnplu.com](http://www.pdnplu.com)

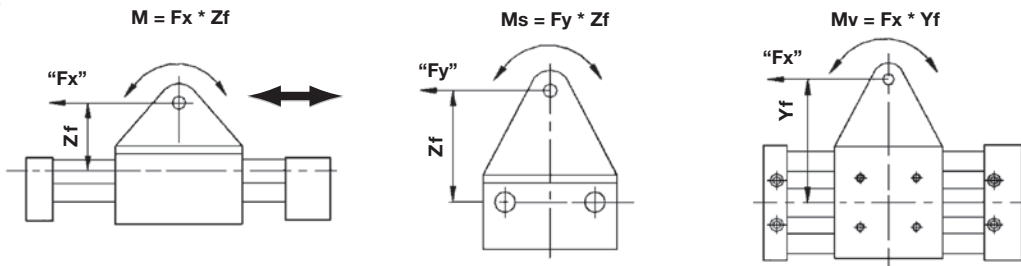
**Load Diagrams**

**Permissible radial loads, horizontal mounting**



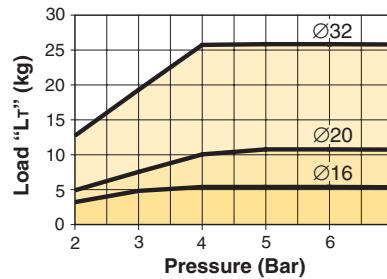
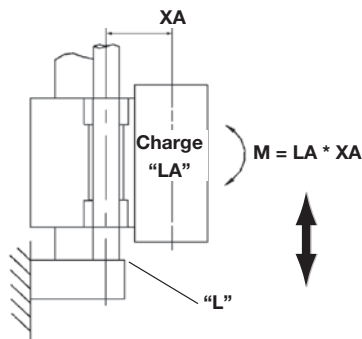
Ø	L Max.	
	(kg)	(lbs.)
16	7	15
20	12	26
32	30	66

**Permissible axial loads, horizontal mounting**



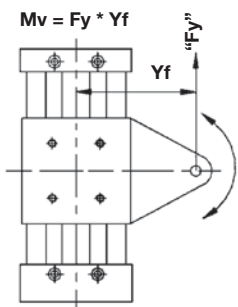
Ø	Max. moment M		Max. moment Ms		Max. moment Mv	
	(Nm)	(in-lbs.)	(Nm)	(in-lbs.)	(Nm)	(in-lbs.)
16	2.4	21	0.5	4.4	2.4	21
20	5	44	1	8.9	5	44
32	15	133	3	26.6	15	133

**Permissible axial loads, vertical mounting**



Ø	Max. load LT* (kg)	Max. XA (mm)
16	5	122
20	10	142
32	24	174

\* at 6.5 bar



- L** = Load guided by external device
  - LA** = Mounting direct onto cylinder
  - LT** = Load weight + guiding device weight + force due to friction
  - Ff\*** = Force due to friction
- \*If force due to friction is unknown, use  $0.1 * (L + LA)$



Rodless Pneumatic Cylinders

OSP-P Series

P1X Series

P1Z Series

GDL Series



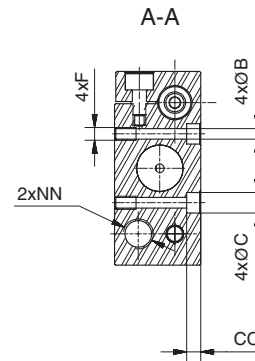
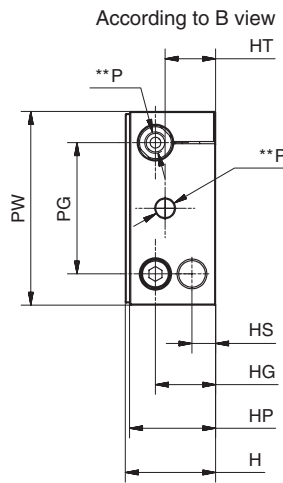
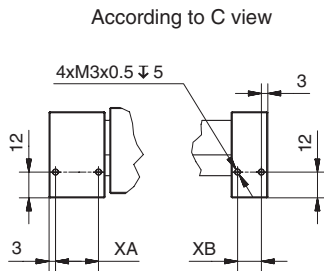
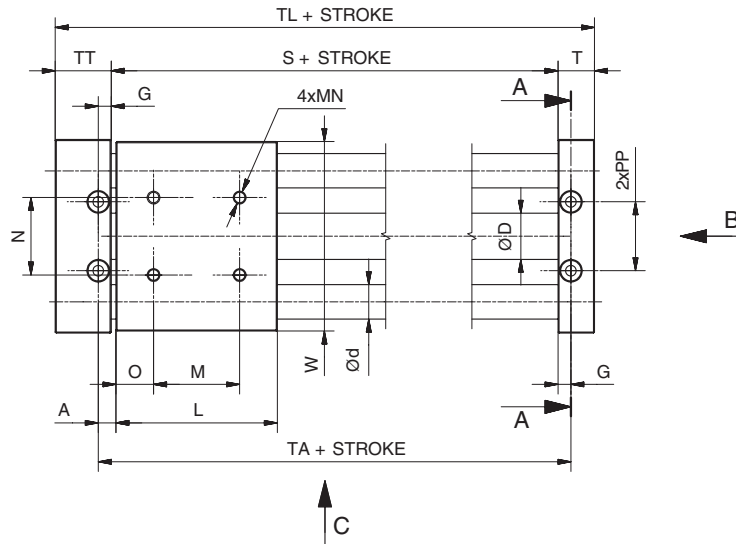
For inventory, lead time, and kit lookup, visit [www.pdnplu.com](http://www.pdnplu.com)

G125

**Parker Hannifin Corporation**  
 Pneumatic Division  
 Richland, Michigan  
[www.parker.com/pneumatics](http://www.parker.com/pneumatics)

**Guided Version**

\*\* = Air supply ports



Ø	A	ØB	ØC	CC	ØD	Ød	F	G	H	HP	HG	HS	HT	L	M	N	MN
16	8 (.31)	4.3 (.17)	8 (.31)	4.5 (.18)	17.4 (.69)	12 (.47)	M5x0.8 x 10	6 (.24)	34 (1.34)	33.5 (1.32)	25 (0.98)	12 (.47)	21.5 (0.85)	65 (2.56)	34 (1.34)	30 (1.18)	M5 x 0.8 x 8
20	8 (.31)	5.5 (.22)	9.5 (.37)	6.5 (.26)	21.4 (.84)	16 (.63)	M6x1 x 10	6 (.24)	42 (1.65)	40 (1.57)	28 (1.10)	12 (.47)	23.5 (.93)	75 (2.95)	40 (1.57)	36 (1.42)	M6 x 1 x 10
32	13.5 (.53)	8.7 (.34)	14 (.55)	8 (.31)	33.6 (1.32)	20 (.79)	M10x1.5 x 15	10 (.39)	66 (2.60)	64 (2.52)	46 (1.81)	20 (.79)	41 (1.61)	91 (3.58)	60 (2.36)	50 (1.97)	M8 x 1.25 x 12

Ø	NN	O	P	PG	PW	PP	T	TT	S	TA	TL	W	XA	XB
16	M10 x 1 x 6	15.5 (0.61)	M5 x 0.8	50 (1.97)	70 (2.76)	27 (1.06)	14 (0.55)	23 (0.91)	69 (2.76)	81 (3.19)	106 (4.17)	68 (2.68)	17 (0.67)	8 (0.31)
20	M14 x 1.5 x 7	17.5 (0.69)	G1/8	61 (2.40)	90 (3.54)	32 (1.26)	17 (0.67)	26 (1.02)	79 (3.11)	91 (3.58)	122 (4.80)	88 (3.46)	20 (0.79)	11 (0.43)
32	M20 x 1.5 x 7	15.5 (0.61)	G1/8	86 (3.39)	122 (4.80)	50 (1.97)	20 (0.79)	28 (1.10)	97 (3.82)	117 (4.61)	145 (5.71)	118 (4.65)	22 (0.87)	14 (0.55)

**G**  
 Rodless Pneumatic  
 Cylinders  
 OSP-P  
 Series  
 P1X  
 Series  
 P1Z  
 Series  
 GD  
 L  
 Series

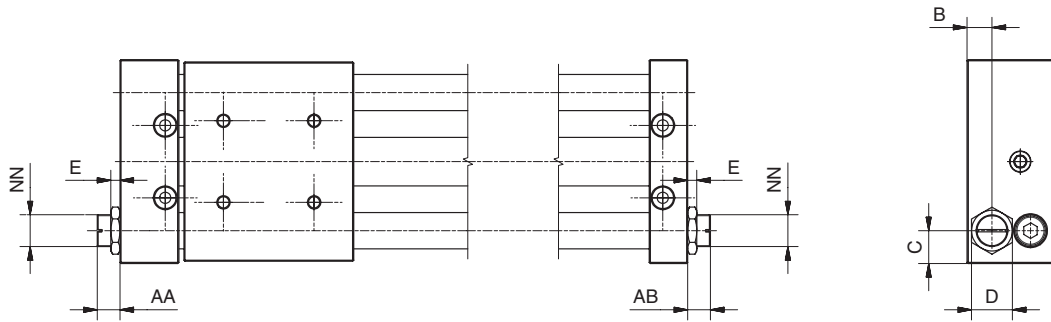


For inventory, lead times, and kit lookup, visit [www.pdnplu.com](http://www.pdnplu.com)

G126

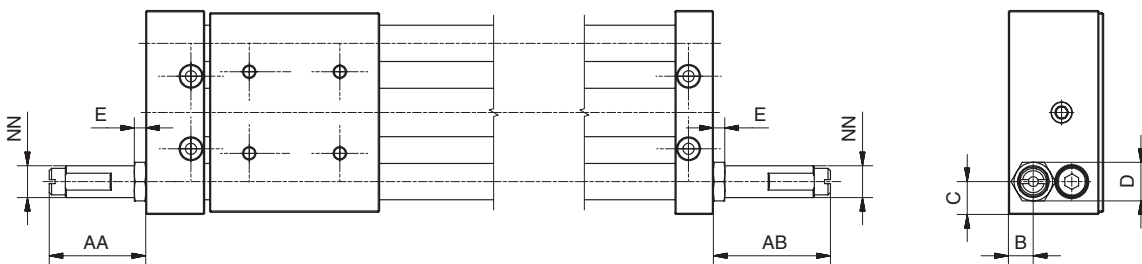
**Parker Hannifin Corporation**  
 Pneumatic Division  
 Richland, Michigan  
[www.parker.com/pneumatics](http://www.parker.com/pneumatics)

**Optional External Adjustable Bumpers**



Ø	AA	AB	B	C	D	E	NN
16	7.5 (0.30)	6.5 (0.26)	12 (0.47)	10 (0.39)	14 (0.55)	4 (0.16)	M10 x 1
20	10 (0.39)	10 (0.39)	11 (0.43)	14.5 (0.57)	18 (0.71)	4 (0.16)	M14 x 1.5
32	11 (0.43)	12 (0.47)	20 (0.79)	18 (0.71)	26 (1.02)	8 (0.31)	M20 x 1.5

**Optional External Hydraulic Shock Absorbers**



Ø	AA	AB	B	C	D	E	NN
16	18 (0.71)	27 (1.06)	12 (0.47)	10 (0.39)	13 (0.51)	3 (0.12)	M10 x 1
20	50 (1.97)	59 (2.32)	11 (0.43)	14.5 (0.57)	17 (0.67)	5 (0.20)	M14 x 1.5
32	56 (2.20)	66 (2.60)	20 (0.79)	18 (0.71)	24 (0.94)	6 (0.24)	M20 x 1.5

**Loads / speeds diagram**

The diagram to the right exhibits the P1Z cylinders maximum capacities with an adjustable bumper.

If the intersection exhibits between speed and load is above the curves, it is imperative to use hydraulic shock absorbers to prevent cylinder damage.

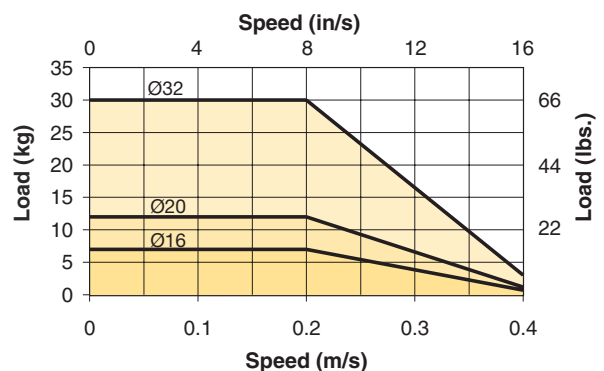
**Example:**

Ø 32 mm cylinder with a 0.3 m/s speed and 25 kg load

Choose the hydraulic shock absorber option

Ø 20mm cylinder with 0.2 m/s speed and 10 kg load

Choose the adjustable bumpers option

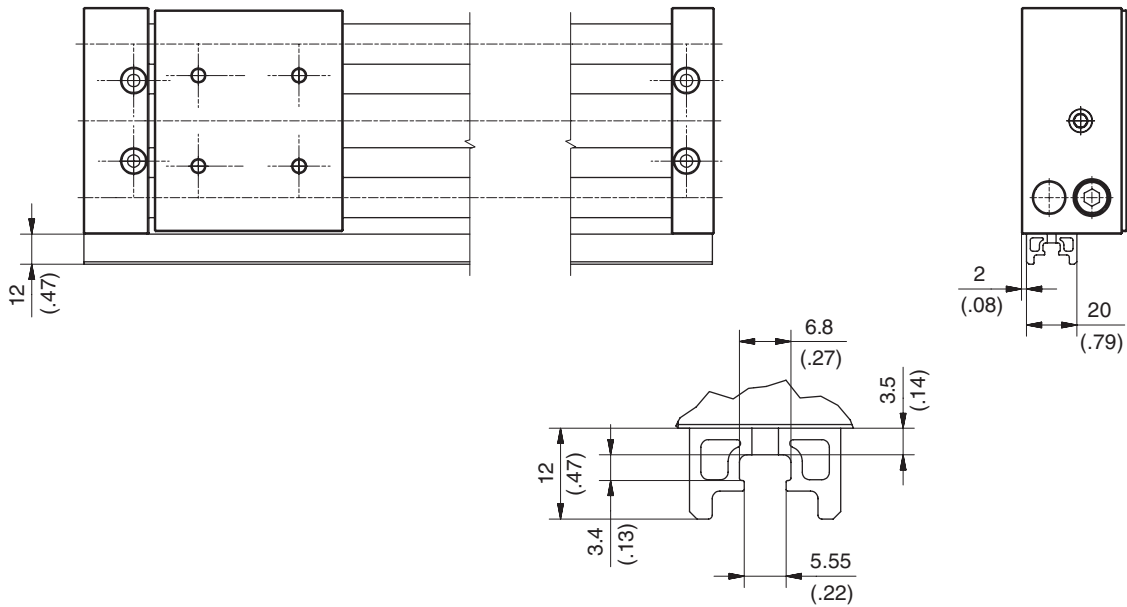


For inventory, lead time, and kit lookup, visit [www.pdnplu.com](http://www.pdnplu.com)

G127

**Parker Hannifin Corporation**  
 Pneumatic Division  
 Richland, Michigan  
[www.parker.com/pneumatics](http://www.parker.com/pneumatics)

**Optional Sensor Rail**

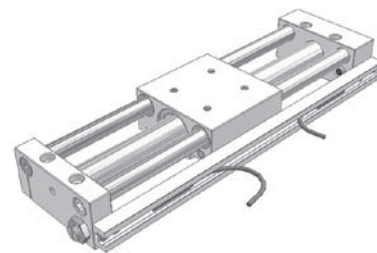


**Detection**

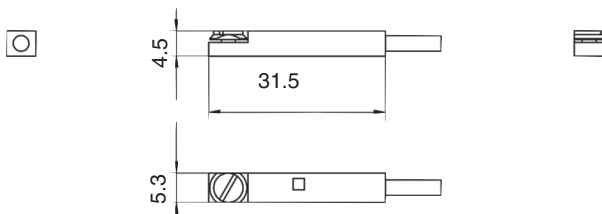
Reed or solid state sensor mounting is possible on one cylinder side only.

External aluminum profile integrates 1 T-slot for sensor mounting.

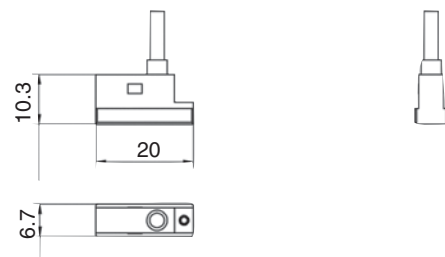
**Dimensions (mm)**



**Drop-in Global Sensor**



**Sensors with connection at 90°**



**Technical Data (see Electronic Sensors Section)**

G	Rodless Pneumatic Cylinders
	OSP-P Series
	P1X Series
	P1Z Series
	GDL Series



For inventory, lead times, and kit lookup, visit [www.pdnplu.com](http://www.pdnplu.com)

G128

**Parker Hannifin Corporation**  
 Pneumatic Division  
 Richland, Michigan  
[www.parker.com/pneumatics](http://www.parker.com/pneumatics)

**End of stroke rubber bumpers (2 pieces)**

Ø	Part number
16	<b>9129609AS</b>
20	<b>9129610AS</b>
32	<b>9129611AS</b>

**End of Stroke Hydraulic Shock Absorber (1 piece)**

Ø	Part number
16	<b>MC25MH-NB</b>
20	<b>MC150MH</b>
32	<b>SC300M-3 NB</b>

**Flow Controls (1 piece)**

Ø	Part number		
	BSP Ports	NPT Ports	Metric Ports
16	-	-	<b>0876300300</b>
20	<b>PTFL4PB6-1/8</b>	<b>0876300400</b>	-
32	<b>PTFL4PB6-1/8</b>	<b>0876300400</b>	-

**Repair kits**

Ø	Basic version	Guided version
16 (Cushioned)	<b>P1ZM016SAN-R</b>	-
16 (Non-cushioned)	<b>P1ZM016SNN-R</b>	<b>P1ZM016GNN-R</b>
20	<b>P1ZM020SAN-R</b>	<b>P1ZM020GNN-R</b>
32	<b>P1ZM032SAN-R</b>	<b>P1ZM032GNN-R</b>



Rodless Pneumatic  
Cylinders

OSP-P  
Series

P1X  
Series

P1Z  
Series

GDL  
Series



For inventory, lead time, and kit lookup, visit [www.pdnplu.com](http://www.pdnplu.com)

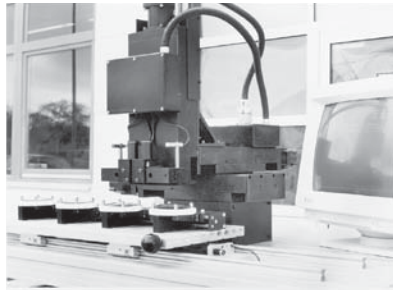
G129

**Parker Hannifin Corporation**  
 Pneumatic Division  
 Richland, Michigan  
[www.parker.com/pneumatics](http://www.parker.com/pneumatics)

**GDL Series**

**Light, Smooth and FAST**

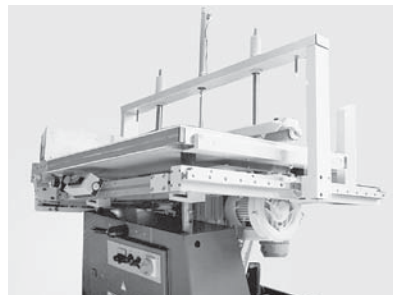
Aluminum roller guides in a cutting machine for spectacle lenses. Both the work piece carriers and the motorized X - Y table axis are equipped with roller guides. The smooth operation and precision of the equipment ensures a fine cutting action.



- Light weight (anodized aluminum)
- Smooth and quiet operation
- Speeds up to 10 m/s
- Acceleration/deceleration up to 40 m/s<sup>2</sup>
- Loading from any direction
- Permanently lubricated guidance system
- Broad product range in various series high performance, standard and stainless steel versions
- High load and moment capacities
- Very cost effective
- Flexible mounting dimensions

Aluminum roller guides in an automatic vibrator for flattening printed sheets of paper. To guarantee even pressure on the sheets of paper, the roller bridge is supported by precision roller guides.

(Baumann company photo)



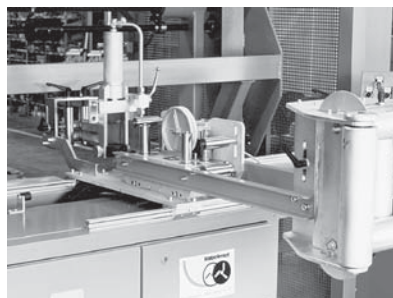
Handling units for medical equipment. Smooth, easy movement with guideline roller guides.

(Dräger company photo)



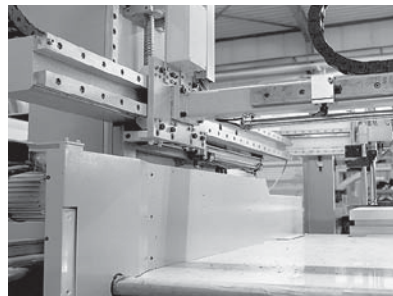
Aluminum roller guides in the sliding carriage of a machine for producing cables. The projecting arm of the carriage is guided by two double rails each with two roller cassettes and can be moved manually with minimal force because of the low friction properties.

(Kabelmat company photo)



Single rail and roller shoe versions of the aluminum roller guide in a handling arrangement for stacks of paper. Various fittings and limit stops for stacking are moved on two axes horizontally and vertically. The robustness and reliability of the roller guides allows for continuous operation under high load conditions.

(Solms company photo)



<b>G</b>	Rodless Pneumatic Cylinders
	OSP-P Series
	P1X Series
	P1Z Series
	GDL Series



For inventory, lead times, and kit lookup, visit [www.pdnplu.com](http://www.pdnplu.com)

G130

**Parker Hannifin Corporation**  
Pneumatic Division  
Richland, Michigan  
[www.parker.com/pneumatics](http://www.parker.com/pneumatics)



## GDL Linear Guides Offer a Variety of Series and Options – High Performance... “Smooth Guidance”

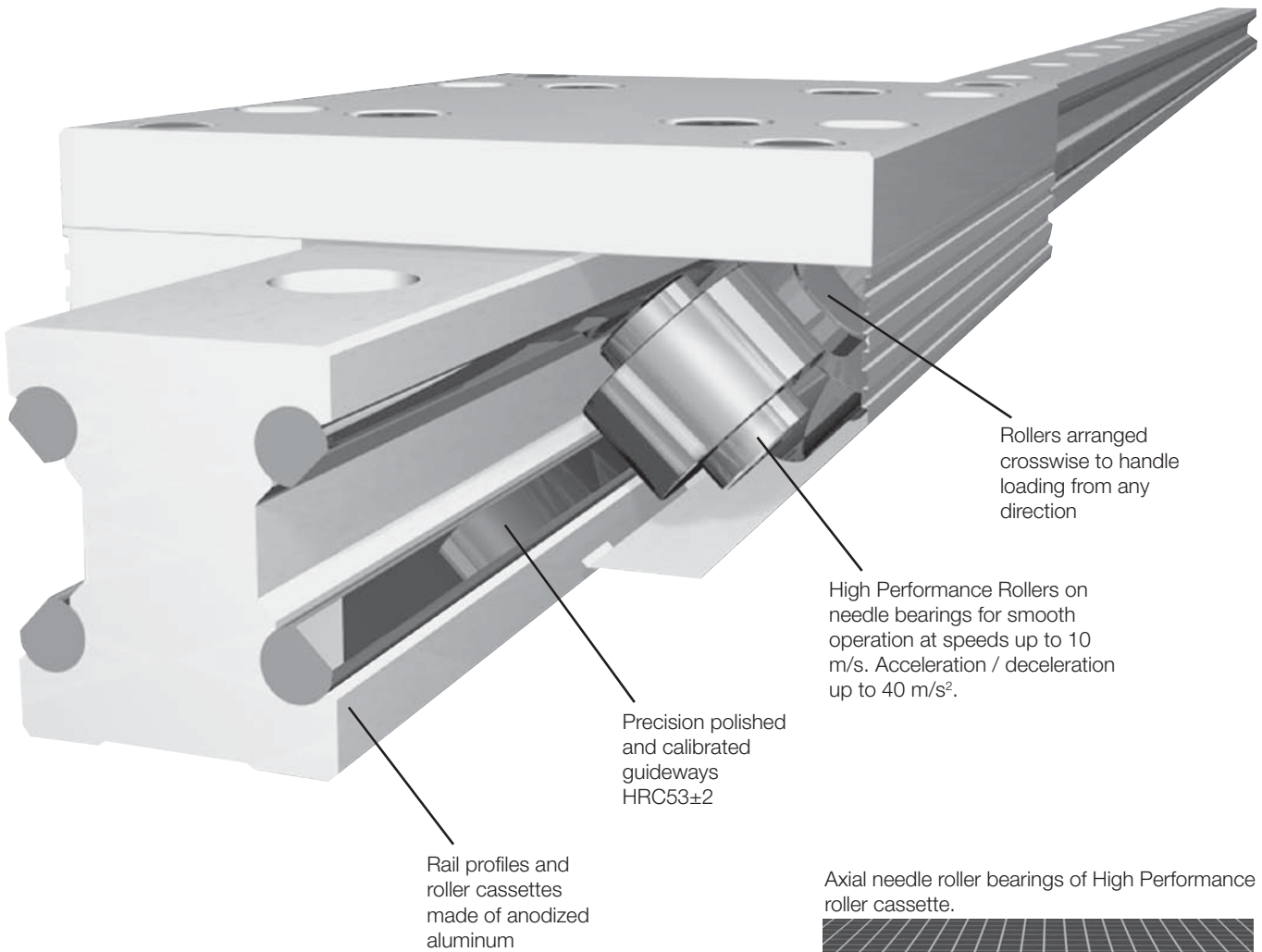
Aluminum roller guides provide smooth operation and high load carrying capacity for industrial automation.

By the use of lightweight aluminum components the moving masses are minimized, travel speeds are increased and actuation energy is saved.

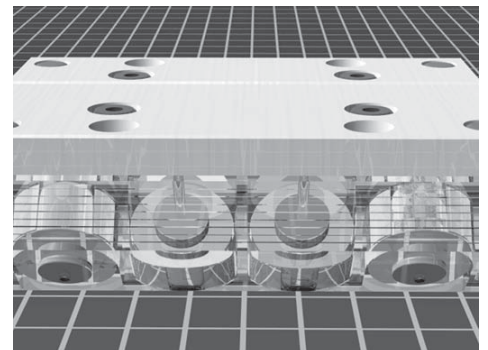
Aluminum roller guides are designed to carry medium weight loads economically. Their smooth action and speeds up to 10 m/s make them ideal for widespread use in many areas of application.

Aside from a main featured High Performance guide, others such as the Standard, Corrosion Resistant, High Dynamics and Grease-free versions are also available.

Aluminum roller guides are available in sizes 12, 15, 20, 25, 35 and 45mm. Rail lengths are from 200 mm to 4000 mm. For longer travel lengths, guide rails can be butt-jointed together.



Axial needle roller bearings of High Performance roller cassette.



Rodless Pneumatic Cylinders

OSP-P Series

P1X Series

P1Z Series

GDL Series



For inventory, lead time, and kit lookup, visit [www.pdnplu.com](http://www.pdnplu.com)

G131

**Parker Hannifin Corporation**  
Pneumatic Division  
Richland, Michigan  
[www.parker.com/pneumatics](http://www.parker.com/pneumatics)

# Features

## High Performance Series:

(Sizes FDC12HP-... thru FDC45HP-...)

The High Performance series is the basis for GDL's development, which is used in the majority of applications. High Performance guides consist of 8 axial needle roller bearings, running on precision polished and hardened alloy spring steel guideways. These guide bearings are grease packed and shielded, while offering the highest load and moment rating capacities within the GDL product line.

## Standard Performance Series:

# Rodless Pneumatic Cylinders GDL Series

(Sizes FDC12SP-... thru FDC45SP-...)

The Standard Performance series is intended for minor loads and moments for particularly economical guidance solutions. Standard Performance guides consist of 8 radial ball roller bearings, running on precision polished and hardened alloy spring steel guideways. These guide bearings are grease packed and sealed, while offering the lowest load and moment ratings available within the GDL product line, with the exception of the Grease-Free and the Anti-Friction / Corrosion Resistant series. Standard Performance series is the second most commonly used GDL guides for various applications and also provides excellent running behavior.

## Ordering Information for GDL Rails

1	2	3	4	5	6	7	8	9	10	11	12	13	14	15	16	17	18	
F	D	R	1	2	H	0	0	0	0	0	0	-	0	0	0	0	0	
<b>Series</b> FD Double sided rail guide* (standard)		<b>Rail Size</b> 1 2* 1 5* 2 0* 2 5* 3 5* 4 5*		<b>Guideway Material</b> H High performance alloy steel* (standard) S Stainless steel			<b>"L11" Dimension</b> 00 Equal on both sides* (standard) ?? Actual dimension (mm)**		<b>Length (mm)</b> - 0 0 0 0 0			<b>Screw Covers</b> 0 None* (standard) 1 Yes*		<b>Long Rail Joining Option</b> 0 None* (standard) 1 Keyed butt joint (size 25-45 only) 2 Unkeyed butt joint				
<b>Rail</b> R Standard		<b>Coatings</b> 0 Anodized aluminum* (standard) Z Custom (consult factory)		<b>Mounting Holes</b> 0 Topside thru hole* (standard) 1 Underside blind thread Z Custom (consult factory)			<b>Coatings</b> 0 Anodized aluminum* (standard) Z Custom (consult factory)			<b>Coatings</b> 0 Anodized and standard hardware* (standard) 1 Anodized and stainless steel hardware* Z Custom (consult factory)			<b>Wiper Options</b> 0 With felt wipers* (standard) 1 Without* 2 With felt wipers and scrapers*					
*Stocked Item																		

## Ordering Information for GDL Cassettes

1	2	3	4	5	6	7	8	9	10	11	12	13	14	15	16		
F	D	C	1	2	H	P	-	0	0	0	0	0	0	0	0		
<b>Series</b> FD Double sided rail cassette* (standard)		<b>Rail Size</b> 1 2* 1 5* 2 0* 2 5* 3 5* 4 5*		<b>Bearing Options</b> AM Non-magnetic (bearing only) HC Axial needle - high performance alloy steel, non-corrosive* HP Axial needle - high performance alloy steel* (standard) SP Single row radial ball - standard performance - alloy steel* (standard) ZZ Factory** (consult factory)			<b>Grease</b> 0 High performance* (standard) Z Custom (consult factory)		<b>Lubrication Options</b> 0 None* (standard) 1 Central lube 2 Central lube (no nipple) Z Custom (consult factory)**			<b>Mounting Holes</b> 0 Topside threaded thru* (standard) 1 Underside hole thru (unthreaded) 2 Underside hole thru (threaded)		<b>Adjustment</b> 0 None* (standard) 1 Adjusted to specific rail*		<b>Cassette Length</b> 0 Normal length* (standard) Z Custom (consult factory)**	
<b>Cassette</b> C Standard		<b>Coatings</b> 0 Anodized and standard hardware* (standard) 1 Anodized and stainless steel hardware* Z Custom (consult factory)		<b>Locking Mechanism</b> 0 None* (standard) 1 "L" ratchet handle* 2 Star grip handle*			<b>Coatings</b> 0 Anodized and standard hardware* (standard) 1 Anodized and stainless steel hardware* Z Custom (consult factory)			<b>Wiper Options</b> 0 With felt wipers* (standard) 1 Without* 2 With felt wipers and scrapers*		<b>Wiper Options</b> 0 With felt wipers* (standard) 1 Without* 2 With felt wipers and scrapers*					
*Stocked Item **Minimum Order Quantity Required																	

**G**  
 Rodless Pneumatic Cylinders  
 OSP-P Series  
 P1X Series  
 P1Z Series  
 GDL Series



For inventory, lead times, and kit lookup, visit [www.pdnplu.com](http://www.pdnplu.com)

G132

**Parker Hannifin Corporation**  
 Pneumatic Division  
 Richland, Michigan  
[www.parker.com/pneumatics](http://www.parker.com/pneumatics)



**Product Line Overview**

Characteristic	Unit	Description
Full profile wipers		Rollershoes and cassette are provided with snap-on full profile wipers. The snap-on full profile wipers are easily replaceable with available wipers kits.
Acceleration and deceleration	m/s <sup>2</sup> (ft/sec <sup>2</sup> )	40 m/s <sup>2</sup> maximum (131 ft/s <sup>2</sup> maximum)
Guide installation		Possible in any position.
Drag adjustment set screw		Cassettes can be adjusted at the factory or by the customer. Rollershoes can be set-up by the customer to incorporate the drag adjustment set screw feature. The drag adjustment set screw components are supplied with each pair of rollershoes.
Standard lubrication		Lifetime lubrication with standard grease-packed roller bearings.
Speed	m/s (ft/s)	Up to 10 m/s (or up to 33 ft/s)
Bearing types		Steel axial needle, Specials on request (ex: anti-magnetic, grease free, high dynamics) - consult factory
Operating temperature	C (F)	-10°C to 80°C (14°F to 176°F) temperature range
Specials available		Custom length cassettes and rollershoes for 100 piece lots minimum. Keyed butt-jointed rail sections for continuous rail lengths of 3900mm and above. Solid continuous length rails up to 3900mm. Offset or non-standard "L11" dimensions on opposite ends of cut rails. Integrated metal scraper with standard full profile wiper currently available. Rail underside blind mounting holes.

**Material specifications**

Rail		Aluminum alloy
Guideways	Standard	High alloy spring steel HRC 53 +/- 2
	Corrosive resistant	Stainless steel guideway/ 46 HRC
Cassettes / rollershoes / top plates		Aluminum alloy
Rollers		Bearing steel / Stainless steel bearing steel

**General Facts Pertaining to All Series:**

Snap-on full profile wipers:	Rollershoes and cassettes can be provided with snap-on full profile wipers. The snap-on full profile wipers are easily replaceable with available wiper kits. See page G139 for respective wiper kit part numbers.
Cassette adjustment:	Cassettes can be adjusted at the factory or by the customer.
Fasteners:	Rollershoes and cassettes use ISO screw quality 8.8 and DIN 433 washers. ISO screw quality 8.8 is recommended for mounting the rails also. Special stainless steel fasteners can be requested as necessary.
Carrying Capacity:	See load and moment rating tables on next page for your guide series of interest.
Guide mounting position:	Optional.
Lengths:	For longer than standard rail lengths, see keyed butt-jointed rail option on page G136.
Lubrication:	GDL Aluminum Roller Guides are permanently lubricated with contained roller bearings grease.
See ordering information on previous page to define your desired GDL guide features for ordering.	

**G**

**Rodless Pneumatic  
Cylinders**

**OSP-P  
Series**

**P1X  
Series**

**P1Z  
Series**

**GDL  
Series**

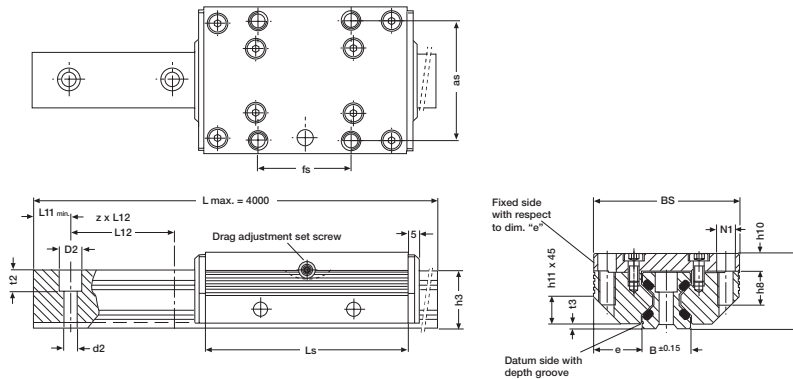


For inventory, lead time, and kit lookup, visit [www.pdnplu.com](http://www.pdnplu.com)

G133

**Parker Hannifin Corporation**  
Pneumatic Division  
Richland, Michigan  
[www.parker.com/pneumatics](http://www.parker.com/pneumatics)

**Cassette with double sided rail**



**Both standard FDC version guides**

Size	Length										L11							
	Ls	B	BS	h3	h9	as	d2	D2	e	fs	h8	h10	h11	min.	L12	t2	t3	N1
12	64	12.0	37	14.7	19	30	3.4	6	12.50	25	8	4.0	6	10	40	5.5	1.4	M4
15	78	15.5	47	18.7	24	38	4.5	8	15.75	30	10	5.0	8	10	60	6.0	2.0	M5
20	92	21.0	63	22.6	30	53	5.5	10	21.00	40	12	7.0	11	10	60	7.0	2.0	M6
25	98	23.0	70	27.0	36	57	6.6	11	23.50	45	16	8.5	13	10	60	10.0	2.5	M8
35	135	32.0	100	37.0	48	82	9.0	15	34.00	62	20	10.5	20	12	80	11.5	3.5	M10
45	165	45.0	120	46.0	60	100	11.0	18	37.50	80	24	13.5	22	16	105	14.5	4.0	M12

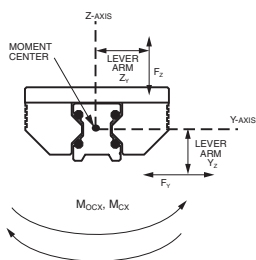
Dimensions (mm)

**Both underside mounting hole FDC version guides (Ref. ordering instructions)**

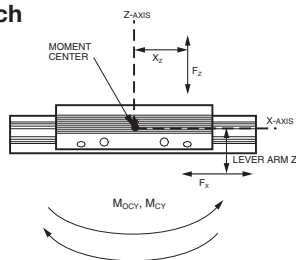
Size	Length										L11							
	Ls	B	BS	h3	h9	as	d2	D2	e	fs	h8	h10	h11	min.	L12	t2	t3	N1
12	64	12.0	37	14.7	19	30	3.4	6	12.50	29	8	4.0	6	10	40	5.5	1.4	M4
15	78	15.5	47	18.7	24	38	4.5	8	15.75	34	10	5.0	8	10	60	6.0	2.0	M5
20	92	21.0	63	22.6	30	53	5.5	10	21.00	40	12	7.0	11	10	60	7.0	2.0	M6
25	98	23.0	70	27.0	36	57	6.6	11	23.50	45	16	8.5	13	10	60	10.0	2.5	M8
35	135	32.0	100	37.0	48	82	9.0	15	34.00	62	20	10.5	20	12	80	11.5	3.5	M10
45	165	45.0	120	46.0	60	100	11.0	18	37.50	90	24	13.5	22	16	105	14.5	4.0	M12

Dimensions (mm)

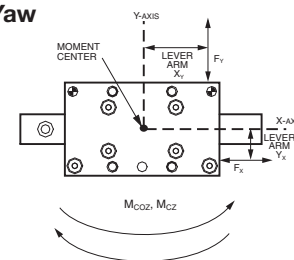
**Roll**



**Pitch**



**Yaw**



**Load & moment rating capacities (for cassettes on double sided rail)**

Dynamic load rating C (N)	Static load rating Co (N)	Static moment rating capacities:			Dynamic moment rating capacities:			Cassette weight (kg)	Rail weight (kg) per "M"	Cassette series
		Roll Mocx (Nm)	Pitch Mocy (Nm)	Yaw Mocz (Nm)	Roll Mcx (Nm)	Pitch Mcy (Nm)	Yaw Mcz (Nm)			
<b>High performance series</b>										
2800	3000	27	43	43	25	40	40	0.1	0.4	FDC12HP-...
4200	3400	37	58	58	45	72	72	0.3	0.8	FDC15HP-...
5400	5400	76	111	111	76	111	111	0.4	0.9	FDC20HP-...
9000	10100	158	222	222	142	198	198	0.6	1.8	FDC25HP-...
12500	18000	423	559	559	294	388	388	1.5	3.2	FDC35HP-...
21200	25900	827	983	983	678	806	806	2.9	5.5	FDC45HP-...



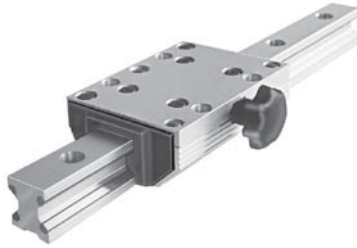
For inventory, lead times, and kit lookup, visit [www.pdnplu.com](http://www.pdnplu.com)

G134

**Parker Hannifin Corporation**  
 Pneumatic Division  
 Richland, Michigan  
[www.parker.com/pneumatics](http://www.parker.com/pneumatics)

**GDL Aluminum Roller Guides**

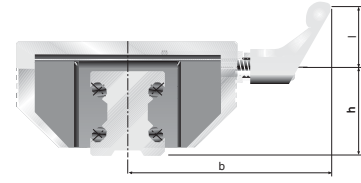
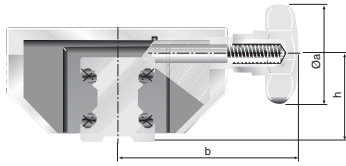
**High performance cassettes with lock device**



The locking cassette with star grip handle can be stopped at any desired location on the rail. The clamping device does not exert forces on the rail guideways.

The clamping device is used in fixtures which are movable manually, clamping and stop ledgers, feeding of tools and work pieces. Also available with L-ratchet handle.

**Special cassette types**



**Star grip handle dimensions**

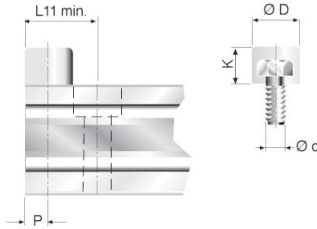
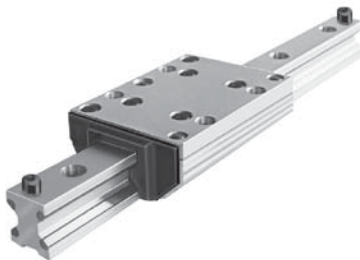
Size	Øa	b	h	Clamp force	Part numbers star grip knob
12	N/A				
15	25	41	19.0	200	<b>FDC15HP-00020000</b>
20	25	49	23.0	250	<b>FDC20HP-00020000</b>
25	32	56	28.0	250	<b>FDC25HP-00020000</b>
35	50	83	38.5	350	<b>FDC35HP-00020000</b>
45	63	101	48.0	750	<b>FDC45HP-00020000</b>

**L-ratchet handle dimensions**

Size	l	b	h	Clamp force	Part numbers L-ratchet handle
12	N/A				
15	45	59.5	19.0	200	<b>FDC15HP-00010000</b>
20	45	67.5	23.0	250	<b>FDC20HP-00010000</b>
25	45	71	28.0	250	<b>FDC25HP-00010000</b>
35	63	96	38.5	350	<b>FDC35HP-00010000</b>
45	78	116	48.0	750	<b>FDC45HP-00010000</b>

Dimensions (mm), Force (N) with normal manual tightening.

**End of stroke stop screws**



The stop screws are screwed into threads (option) on the guide rails. The end of stroke stopping energy is reduced by a rubber cap. With guide rails where the L11 is less than the standard minimum, we offset the mounting hole by half of its diameter.

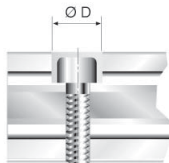
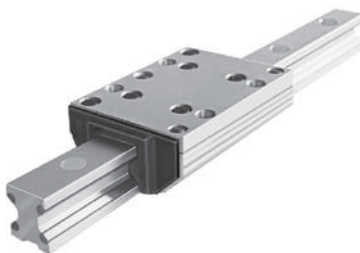
**Note:** Customer must drill and tap the holes for the stop screws.

Size	Ød	ØD	K	L11 min.	P	Part number
12	M5	12	8	15.0	6.0	<b>63504A</b>
15	M5	12	8	16.0	6.0	<b>63504A</b>
20	M5	12	8	17.0	6.0	<b>63504A</b>
25	M6	15	10	20.5	7.5	<b>63505A</b>
35	M8	19	13	26.5	9.5	<b>63506A</b>
45	M10	24	16	33.0	12.0	<b>63507A</b>

Dimensions (mm)

**GDL Accessories**

**Rail mounting screw covers**



**Material:** Wear resistant plastic, resistant to oil and aging.

**Mounting:** Put a plastic plate on top and pound in uniformly. Remove residual burrs with a soft brush or fingernail.

**Note:** Use respective part numbers for ordering separately or include in rail part number.

Size	Cylindrical screw DIN912	Ø D	Part number
12	M3	6	<b>87752A</b>
15	M4	8	<b>42074FIL</b>
20	M5	10	<b>87754A</b>
25	M6	11	<b>87755A</b>
35	M8	15	<b>6973</b>
45	M10	18	<b>87757A</b>

Dimensions (mm)



For inventory, lead time, and kit lookup, visit [www.pdnplu.com](http://www.pdnplu.com)

**GDL Aluminum roller guides with wipers**

**Version with wipers**

Integrated into an additional cover, a felt wiper is saturated with oil. Although dependent on the degree of contaminants, these wipers last for some 6000km, after which the felt wipers can either be washed or replaced.

For optimal cassette rolling performance, all holes in the guide rails should be filled with the plastic rail mounting screw covers.

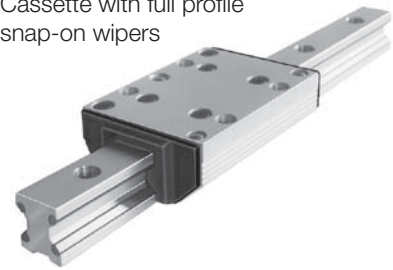
**Part numbers for replacement wiper kits**

FDC series and size	Respective part number
12	<b>84457B</b>
15	<b>84480B</b>
20	<b>84481B</b>
25	<b>84482B</b>
35	<b>84483B</b>
45	<b>84484B</b>

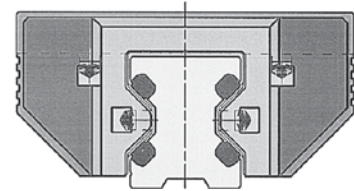
\*wiper kits are sold in pairs

NOTE: Use respective part numbers for ordering separately as replacements, or specify in cassette part number.

Cassette with full profile snap-on wipers



Full profile snap-on wiper



**GDL's keyed butt-jointed rail option**

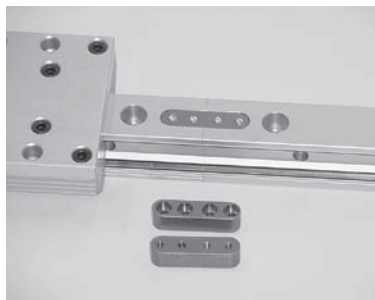
GUIDELINE rails can be precisely fastened together using a factory offered keyed butt-joint option for continuous rail lengths, as shown in Figures 1 & 2.

Two rail sections are clamped together with mating round bar stock pieces that seat tangent to both rail section guideways on each side of the rail. While the rail sections are clamped together, a keyway slot is machined in the top and bottom sides of the rail, across the butt-joint. Screw holes are then drilled through the rail inside the keyway slot, so the opposing keyways can be drawn together tightly with screws. The round bar stock clamp is then removed, providing a rigid and well aligned keyed butt-joint.

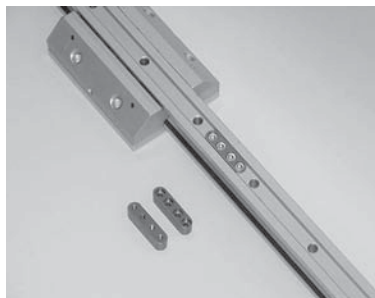
The keyed butt-joint option provides optimum alignment of all guideways from one rail section to the next. This allows for optimum "smooth" guidance of the cassette bearings, while crossing rail butt-joints.

The keyed butt-jointed rail option is currently available in the FDR version 25, 35, & 45 mm rail sizes. For a keyed butt-joint on rail sizes 25, 35 or 45 mm, specify P/N:# GDL-BJK

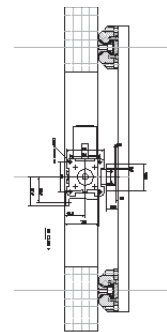
Consult factory for other size possibilities.



**Figure 1**



**Figure 2**



**Figure 3**

GDL linear guides couple well with various structural aluminum extrusions and Parker-Origa OSP-P actuators. Mounting can be easily accomplished using standard fasteners and mounting brackets. See Figure 3 above.

**G**  
Rodless Pneumatic  
Cylinders

OSP-P  
Series

P1X  
Series

P1Z  
Series

GDL  
Series



For inventory, lead times, and kit lookup, visit [www.pdnplu.com](http://www.pdnplu.com)

**1. Features of the Guide System**

Aluminum roller guides consist of a double sided rail and a roller cassette or two single sided rails and two roller shoes. Aluminum roller guide rails and cassettes are made of aluminum alloy. The rollers are very smooth running on precision polished guideways made of high alloy spring steel. The special cross pattern orientation of the running rollers provides high load and moment capacity in all directions.

Their special features are: light weight, small dimensions, and high speed of displacement. Aluminum roller guides are economical and universal handling components, which are mostly or all corrosion-resistant and available at a favorable price.

**2. Size of the Guide System**

To select the right guide size, first the moments and forces acting on the bearing have to be determined.

Recommended safety factors (with ISO screws quality 8.8):

- Thrust load      S > 1.3
- Tensile load     S > 4.0
- Moment load    S > 6.0

**3. Material**

The basic body of GDL aluminum roller guides is made of aluminum alloy. The guideways consist of hardened, high alloy spring steel or of stainless steel. By using basic bodies of aluminum, the moved masses are reduced which allows light-weight construction requiring lower moving forces and reduced energy consumption. Still the integrated GDL system sustains high load and moment ratings.

**4. Operating Temperature**

GDL linear guides can be operated within a temperature range from -10° C up to 80°C. For other temperatures, please consult factory.

**5. Screwed Connections**

GDL linear guides are fixed to the mating structure by the mounting holes in the rails and the cassettes. ISO screw quality 8.8 should be used with DIN 433 washers.

To secure the screwed connections, we recommend that suitable locking means be utilized as necessary.

Mounting screw torque specifications:

Screw	Quality 8.8 [Nm]
M3	1.1
M4	2.5
M5	5.0
M6	8.5
M8	21.0
M10	41.0
M12	71.0

**6. Wipers**

The guideways of aluminum roller guides are equipped with wipers to protect against coarse environmental contamination.

**7. Slide Resistance / Adjustment**

Follow the steps on how to adjust GDL cassettes to the rail.

The new GDL catalog has many changes due to an expanded product line. The change to feature descriptive part numbering was done to accommodate all current and future offerings of the GDL product. The goal is to have standard features and options available, for a perfect fit into your application.

Included in the chart below are hex sizes, drag resistance and torque ratings for adjusting the cassette.

**GDL Chart**

	FDC 12	FDC 15	FDC 20	FDC 25	FDC 35	FDC 45
Top plate hex (mm)	2	3	4	4	5	6
Top plate torque (in lbs)	n/a	22.1	44.3	44.3	75.2	186
Adjustment hex (mm)	1	3	3	4	4	4
Drag resistance (oz) HP, HC, GF, VA	1.8-7.9	3.6-10.8	5.4-16.2	7.2-21.6	10.8-32.4	12.6-37.7
Drag resistance (oz) SP & SC	.7-1.8	1.8-3.6	3.6-7.2	5.4-10.8	7.2-14.4	9-18
Drag resistance (oz) HD	n/a	n/a	n/a	9-18	14.4-25	18-28.7

**7.1 GDL Adjustment Procedure**

**Do not measure sliding resistance with wipers on.**

- 1) Lay the rail out on the flat surface with the **datum** line facing away from you. Anchor the rail to keep it from shifting when sliding resistance is applied to the cassette.

*The datum line is a reference groove on one side of the rail.*

- 2) Set the roller cassette on the rail with the adjustment screw facing towards you, while the datum line on the rail is away from you. Do not install the wipers on the cassette yet.

*Do not install the wipers yet.*

- 3) Make sure the four bolts on the adjustable side of the cassette are slightly loose and the bolts on the fixed side are tight before adjusting the drag screw.

*One side of the cassette is fixed and the other side is floating.*

- 4) The drag hex screw is located on one side of the cassette. Adjust the screw in for more drag and out for less. Do not try to adjust cassette with top plates bolts tight.

*See the chart for drag adjustment hex screw size.*

- 5) Adjust the drag on the cassette by sliding as it slides down the rail. Feel for an even amount of resistance as you turn the hex screw in and out.

- 6) Tighten down the top plate bolts to the proper torque specification. The tightening of the top plate bolts will add some resistance. If necessary, the adjustment procedure can be repeated for better sliding resistance for your application.

*See the chart for top plate hex size and torque rating.*

- 7) If the adjustment is done without a scale, it should move evenly. Some examples of improper adjustment are: If the



For inventory, lead time, and kit lookup, visit [www.pdnplu.com](http://www.pdnplu.com)

cassette “hops”, it is too tight. If it is too loose, the top plate of the cassette will have play. Try to be in the middle.

- To check your settings use a pull or push style scale. Slide the cassette down the entire rail at an even speed, measuring the drag resistance. Your highest drag rating should be referenced when looking at the chart.

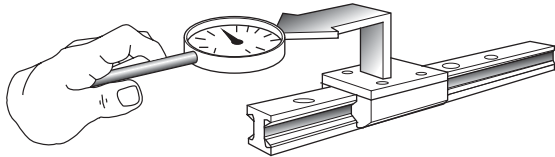
See the chart for drag resistance ratings for the size and type of cassette.

- Install the clip on wipers. The wipers will add between 1-3 ounces of resistance. The wipers do not add any additional roller preload to the rail.

The clip on wipers can be installed at this time.

**7.2 Double Sided Rail and Cassette**

Aluminum roller guides are adjusted in such a way that the required stiffness under load is obtained. If self adjustment is preferred, we recommend that you measure the slide resistance as shown below. Before doing so, the mating structure should be checked for dimensional accuracy and flatness.



The cassettes which are mounted on the rails are adjusted clearance-free, without play. This adjusting method is required at the point on the rail where the cassette travels with the least slide resistance. Adjustment is completed in the non-loaded condition. The tolerances below refer to this condition.

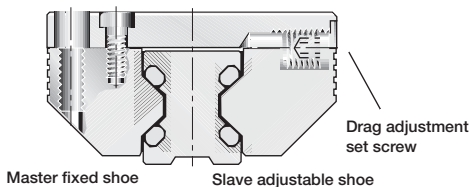
**Slide resistance adjustment tolerance [N]**

Series	FDC_HP, FDC_HC, FDC_AM, FDC_GF, FDC_VA						FDC_SP, FDC_SC						FDC_HD		
	12	15	20	25	35	45	12	15	20	25	35	45	25	35	45
Adjust. value	0.5	1.0	1.5	2.0	3.0	3.5	0.2	0.5	1.0	1.5	2.0	2.5	2.5	4.0	5.0
Max. value	2.0	3.0	4.5	6.0	9.0	10.5	0.5	1.0	2.0	3.0	4.0	5.0	5.0	7.0	8.0

All values are without wipers

Tolerances in the guide system may cause slight variations in the slide resistance, when the adjusted cassette is moved along the guide rail.

**7.3 Double Sided Rail and Roller Cassette**



To change the clearance setting, first the slave adjustable shoe screws on the cassette top plate are slightly loosened.

Afterwards, the drag adjustment set screw is turned to increase or decrease slide resistance of the cassette. Turning the drag adjustment set screw effects a displacement of the roller shoe in relation to the cassette top plate.

After re-tightening of the cassette top plate, the slide resistance can be checked. This procedure can be repeated until the desired slide resistance is achieved.

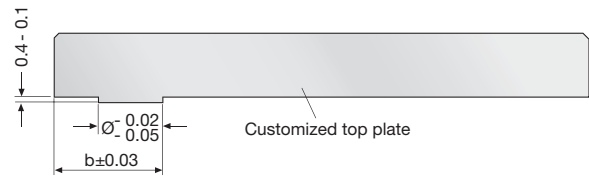
**7.4 Rails and Rollershoes**

When installing, it is important to distinguish between the master fixed side and the slave adjustable side rollershoe and rail. The rail on the master fixed side is aligned to the mating structure and fastened securely by all screws.

The rail on the slave adjustable side should be lightly tightened and movable with light force during initial alignment of parallel rails. Gauge blocks should be used between the parallel rails, by locating off the aligned and mounted master rail, in order to align the slave rail parallel to the master rail. Slave rail mounting bolts should be tightened as the slave rail is aligned at each bolt position. See paragraph 11.3 for further instructions on mounting parallel single sided rails.

**7.5 Centering Groove on the Master Fixed Shoe and Custom Top Plate**

Each pair of rollershoes are provided with centering grooves for optimum alignment to their mating top plate during mounting. One rollershoe should be designated as the master fixed rollershoe, even though both are designed with a centering groove on their top surface. The other shoe will serve as the slave adjustable side rollershoe. The mating customized top plate should be machined with a centering shoulder according to the following data.



Size	a	b
12	4,5	9,6
15	5,0	12,6
20	7,5	16,1
25	10,5	17,6
35	12,5	26,1

**7.6 Adjusting Cassette Built with Rollershoes and Custom Top Plate**

The centering shoulder on the top plate should be assembled with its respective fixed rollershoe centering groove and securely torqued to recommended specification. See cassette screw torque specifications under step 5, on previous page.

Assemble the adjustable rollershoe to the top plate also, parallel to the fixed rollershoe on the same side of the top plate. Its fasteners should be lightly tightened so that the adjustable rollershoe can be moved with light finger pressure.

**G**  
 Rodless Pneumatic Cylinders  
 OSP-P Series  
 P1X Series  
 P1Z Series  
 GDL Series



For inventory, lead times, and kit lookup, visit [www.pdnplu.com](http://www.pdnplu.com)



## Technical Data

As assembled cassette can then be slid onto parallel rails, while keeping the fixed rollershoe on the master fixed rail side. The incorporated drag adjustment set screw can then be turned clockwise to remove cassette play, or counter clockwise to reduce slide resistance while maintaining zero play.

Once the desired slide resistance is achieved with no cassette play, the adjustable rollershoe fasteners can also be torqued to specification.

### 8. Running accuracy

The running accuracy is measured from the top plate surface of the cassette, to the ideal straight line of travel. Running accuracy of the cassette to the rail is +/- .03mm (.0012") per meter, granted no greater than (.0024") straightness deviation per meter is maintained when mounting the rail.

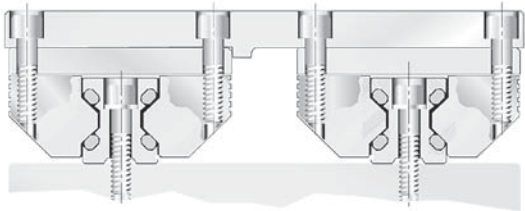
### 9. Contact and support surfaces

The contact and support surfaces have a substantial influence on functioning and precision of linear guides. Depending on the functional requirements of the system, the mating structure has to be machined with the corresponding degree of precision.

Machining errors on the mating structure will otherwise add to the running error of the guide system. In order to assure troublefree functioning, we recommend that a max. straightness deviation of  $\leq 0.1 \text{ mm}$  (.0039") per running meter be maintained when mounting the rail.

### 10. Design hints

#### 10.1 Parallel double sided rails and cassettes



The master fixed rail should always be established straight and true first, within the maximum straightness deviation specified in paragraph 9. With parallel rail arrangements, both rails should be mounted on the same mounting surface elevation and treated with equal surface preparation and tolerancing practices. Precise alignment in terms of spacing, parallelism and height is very important.

When coupled parallel to a driving actuator system, the adjustable side of the cassette should be placed on the side closest to the driving actuator. This will minimize driving actuator torque transferred to the adjustable side of the cassette.

### 11. Guide mounting instructions

The useable load capacity is influenced by the connection between the guide elements and the mating structure. For this reason, a flat, straight and solid secure mounting surface should be provided. Adequate support of qualified loads and moments can then be achieved, along with desired running accuracy.

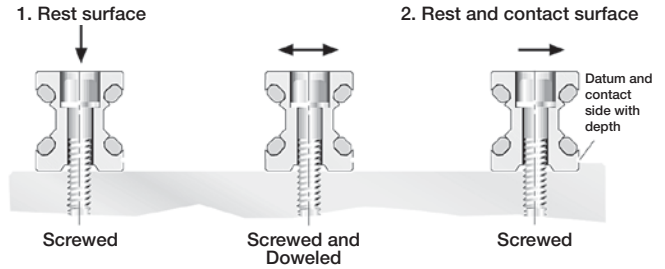
#### 11.1 Mounting Double Sided Rails and Cassette

Depending on the load situation, certain double sided rails

## Rodless Pneumatic Cylinders GDL Series

should either be screwed or screwed and dowelled, and respectively put into grooves or against a shoulder.

The rails can be secured best against shoulders and are screwed or screwed and dowelled to the mating structure.



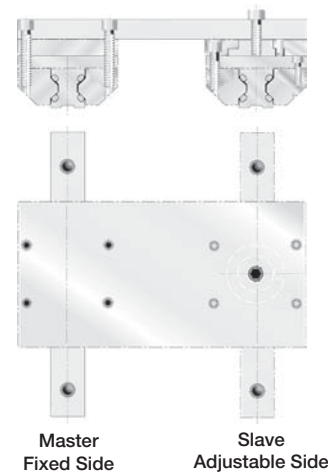
After final adjustment of rail straightness and parallelism, the rail mounting screws are tightened starting in the middle of the rail length. Rail mounting bolts should be torqued to specification by alternating between each bolt. The installer should start with the bolt in the center of the rail length and proceed by alternating between each bolt left of center and each bolt right of center, while working towards both ends of the rail.

Afterwards, the cassette should be moved back and forth along the total stroke distance of the rail. If the cassette travels smoothly, the mounting process can proceed or be completed.

#### 11.2 Mounting Parallel Double Sided Rails and Cassettes

With parallel double sided rail arrangements, we recommend that the master fixed rail side and slave adjustment rail sides of the guide system be identified. This allows optimum tolerances in parallelism to be achieved best by adjusting the slave adjustable rail, parallel to the master rail. The master fixed rail side should be mounted first to achieve the initial line of straight travel.

The example below displays a convenient method for adjusting the slave adjustable rail parallel to the fixed master rail. Once the cassette travel is smooth, without play, one can proceed with rail mounting.



Note that the top plate spanning across the cassettes on opposite rails is completely bolted down to the cassette on the master fixed side only. The top plate end over the slave adjustable side is only bolted in one location, in the center of the slave adjustment side cassette. With one bolt holding the

## Technical Data

top plate to the slave adjustment side cassette, this cassette can pivot while the slave adjustable rail self-aligns parallel to the fixed master rail side. The floating top plate setup is stroked along the entire rail length, to establish the parallelism between the two rails.

Calibrated gauge blocks can also be used to establish equal integrity in rail parallelism. The installer should seat and temporarily clamp short pieces of precision ground round stock, tangent to the two guideways on the inside of each rail.

Rail Size	Precision Round Stock Sizes Ø mm
12	11
15	11
20	14
25	16
35	27
45	35

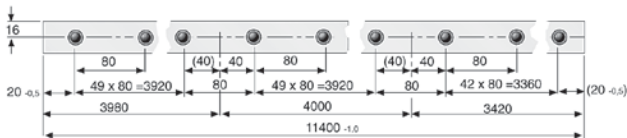
The calibrated gauge blocks can then be used, to locate off the precision round stock on the master fixed rail, in order to set the slave adjustable rail parallel. The gauge blocks are then locating the same way that the floating top plate is, by referencing both the master and slave rail guideway surfaces to establish parallelism.

Once the slave adjustable rail has been self-aligned, its bolts should also be torqued to specification in the order mentioned in paragraph 11.1. The top spanning across both cassettes on opposite rails, can then be securely fastened using all cassette mounting bolt holes.

## 12. Keyed Butt-jointing of Rail Sections

### 12.1 Rail Hole Spacing

Butt-jointed rails over L = 4000 mm are sectioned together according to the GDL standard. See "GDL's Keyed Butt-Jointed Rail Option" on page G136. Butt-jointed rails sections are cut so that the standard rail mounting hole spacing is maintained across all butt-joints.



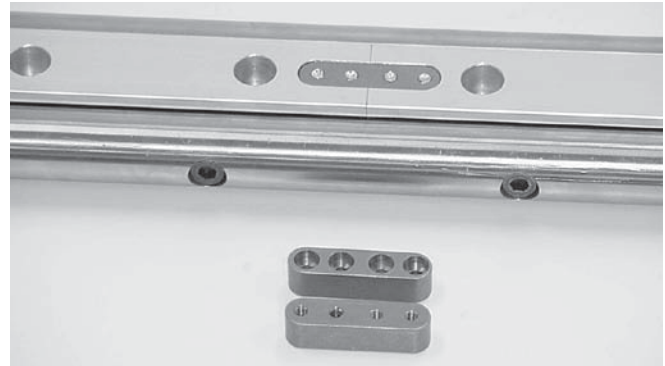
Keyed butt-jointed rails are usually shipped completely assembled, but sometimes must be shipped partially assembled, due to shipping length limitations and shipping care. Partially assembled butt-jointed rails are supplied with a butt-jointing clamping fixture and the keyways and screws for fastening rail section together.

### 12.2 Mounting of butt-jointed rails

Clean mounting surfaces, then place rail sections loose on the guide path, one behind the other. Lay the rails in their correct sequence of the system design (i.e.: 1, 2, 3, 4...etc.). The orientation of the depth groove on the lower surface of the rail should always be on the same side for all rail sections being butt-jointed.

## Rodless Pneumatic Cylinders GDL Series

Any non-assembled rail sections should be aligned with the factory supplied butt-joint clamping fixture as displayed below.



See explanation of "GDL's Keyed Butt-Jointed Rail Option" on page G136.

Once all rail sections are assembled, the complete guide path can be aligned and fastened. Alignment and fastening should be conducted according to the applicable guide arrangement and steps previously described in this technical information section.

G

Rodless Pneumatic  
Cylinders

OSP-P  
Series

P1X  
Series

P1Z  
Series

GDL  
Series



For inventory, lead times, and kit lookup, visit [www.pdnplu.com](http://www.pdnplu.com)

G140

**Parker Hannifin Corporation**  
Pneumatic Division  
Richland, Michigan  
[www.parker.com/pneumatics](http://www.parker.com/pneumatics)

**Units Conversion Tables**

**Force Conversions:**

Multiply	By Conversion Factor	Result
pound-force	4.448	Newton
Newton	0.225	pound-force
kilogram-force	9.807	Newton
Newton	0.102	kilogram-force

**Acceleration Conversions:**

Multiply	By Conversion Factor	Result
feet/section <sup>2</sup>	0.305	meter/second <sup>2</sup>
meter/second <sup>2</sup>	3.281	feet/second <sup>2</sup>
inch/second <sup>2</sup>	0.025	meter/second <sup>2</sup>
meter/second <sup>2</sup>	39.370	inch/second <sup>2</sup>

**Mass Conversions:**

Multiply	By Conversion Factor	Result
ounce	28.349	gram
gram	0.035	ounce
kilogram	35.279	ounce
gram	0.001	kilogram
pound	0.453	kilogram
kilogram	2.205	pound

**Bending Moment or Torque Conversions:**

Multiply	By Conversion Factor	Result
pound-foot	1.356	Newton-meter
Newton-meter	0.737	pound-foot
Newton-meter	0.102	kilogram-meter
Kilogram-meter	9.807	Newton-meter

**Velocity conversions:**

Multiply	By Conversion Factor	Result
mile/hour	1.609	kilometer/hour
kilometer/hour	0.621	mile/hour
feet/second	0.305	meter/second
meter/second	3.281	feet/second
inch/minute	0.025	meter/minute
meter/minute	39.370	inch/minute

**Length conversions:**

Multiply	By Conversion Factor	Result
inch	25.4	millimeter
millimeter	0.039	inch
inch	0.025	meter
meter	39.370	inch
foot	0.305	meter
meter	3.281	foot



Rodless Pneumatic Cylinders

OSP-P Series

P1X Series

P1Z Series

GDL Series



For inventory, lead time, and kit lookup, visit [www.pdnplu.com](http://www.pdnplu.com)

# GDL Application Sheet

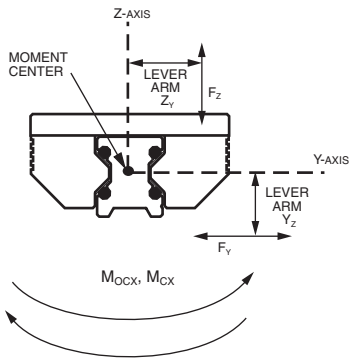
Distributor: \_\_\_\_\_ End-User: \_\_\_\_\_

Salesperson: \_\_\_\_\_

Phone: \_\_\_\_\_ Fax: \_\_\_\_\_ e-mail: \_\_\_\_\_

Other Information: \_\_\_\_\_

## Roll

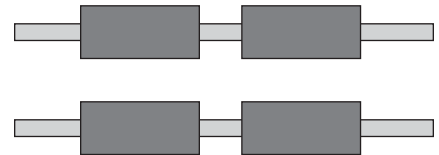


Roll load \_\_\_\_\_

X - Distance \_\_\_\_\_

Y - Distance \_\_\_\_\_

Z - Distance \_\_\_\_\_

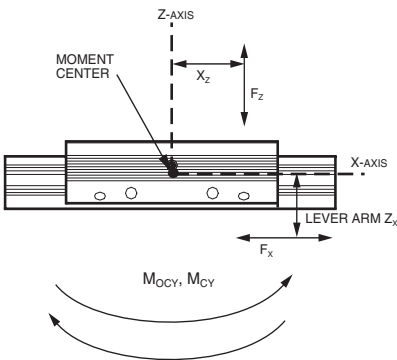


Length of rails \_\_\_\_\_

Distance between rails \_\_\_\_\_

Distance between cassettes on each rail \_\_\_\_\_

## Pitch

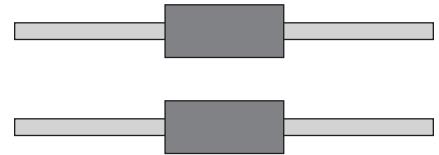


Pitch load \_\_\_\_\_

X - Distance \_\_\_\_\_

Y - Distance \_\_\_\_\_

Z - Distance \_\_\_\_\_



### Technical Data:

Stroke \_\_\_\_\_

Horizontal \_\_\_\_\_

Vertical \_\_\_\_\_

Velocity / Speed \_\_\_\_\_

Acceleration \_\_\_\_\_

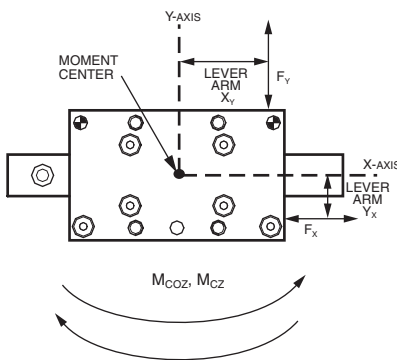
Load / Mass \_\_\_\_\_

Load Distances \_\_\_\_\_

Lifetime Desired \_\_\_\_\_

**Environment:**  
 (Dirt, Humidity...)

## Yaw



Yaw load \_\_\_\_\_

X - Distance \_\_\_\_\_

Y - Distance \_\_\_\_\_

Z - Distance \_\_\_\_\_



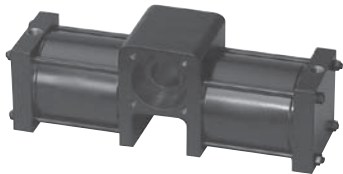
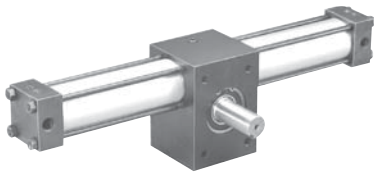
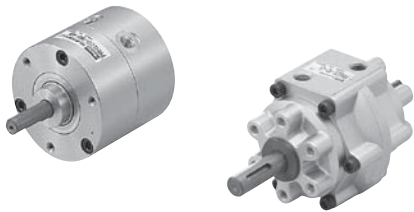
For inventory, lead times, and kit lookup, visit [www.pdnplu.com](http://www.pdnplu.com)

G142

**Parker Hannifin Corporation**  
 Pneumatic Division  
 Richland, Michigan  
[www.parker.com/pneumatics](http://www.parker.com/pneumatics)

**G**  
 Rodless Pneumatic Cylinders  
 OSP-P Series  
 P1X Series  
 P1Z Series  
 GDL Series

**Rotary Actuators**  
**Vane / Rack & Pinion Series**



<b>Overview</b>	H2
<b>PV Series – Vane</b>	
Features	H3-H4
Ordering Information	H4
Specifications	H5
Technical Data	H6
Dimensional Data	H7
Options	H7-H10

<b>PRNA / PRN Series – Vane</b>	
Features	H11-H12
Ordering Information	H12
Specifications	H13-H14
Dimensional Data	H15-H17
Options	H18

<b>PTR Series – Rack &amp; Pinion</b>	
Features	H23-H24
Ordering Information	H24
Specifications	H25-H26
Technical Data	H27
Dimensional Data	H28
Options	H29-H37

<b>B671 / F672 Series – Rack &amp; Pinion</b>	
Features	H38-H39
Ordering Information	H40
Specifications	H39
Dimensional Data	H41

<b>HP Series – Rack &amp; Pinion</b>	
Features	H42-H43
Ordering Information	H43
Specifications	H44
Dimensional Data	H45
Options	H45-H46

## Overview

### Selection Guide

Basic performance features of the rotator product line are shown below. See product sections for greater detail and ordering information.

Type	Vane		Rack & Pinion		
Series	PV	PRN(A)	PTR	B671	HP
Standard Rotations	95°/100° <sup>1</sup> 275°/280° <sup>2</sup>	90°/100° <sup>1</sup> 180° <sup>2</sup> 270°/280° <sup>2</sup>	90° 180° 270° 360°	90° 180°	90° 180°
Maximum Torque at 100 PSI (lb-in)	1800	2540	2000	2500	10,000
Maximum Air Pressure Rating (PSI)	150	100/140	250	140	100
Shaft Bearing Type	Ball or Composite Bushing	Composite	Radial Ball Bushing	Bronze Bushing	Bronze Bushing
Non-Lube Service	●	●	●	●	●
Metric (M) or Imperial (I)	I	M	M,I	I	I
Switch Options	Hall Effect	●	●		
	Reed	●	●	C	
	Proximity Sensor			●	●
Shaft Options	Double End	●	●		
	Female			●	●
	Preload Keyway			●	
	Special	C		C	C
Rotation Options	Stroke Adjust	●	●		●
	Cushions			●	●
	Bumpers	●	●	●	
	Shock Absorbers		●	●	
Port Relocation	●	●	●	C	●
3-Position	C		●		
Air / Oil			●	● <sup>3</sup>	
Zero Backlash	●	●	●		
Fluorocarbon Seals	●	●	●		●
Flange Mount	●	●	●		
Washdown	●	C	C		
Clean Room		C			

● = Available from catalog

C = Consult Factory

<sup>1</sup> Double vane

<sup>2</sup> Single vane

<sup>3</sup> Hydro-check option



For inventory, lead times, and kit lookup, visit [www.pdnplu.com](http://www.pdnplu.com)

H2

**Parker Hannifin Corporation**  
Pneumatic Division  
Richland, Michigan  
[www.parker.com/pneumatics](http://www.parker.com/pneumatics)

**PV Series**

**HEADS**

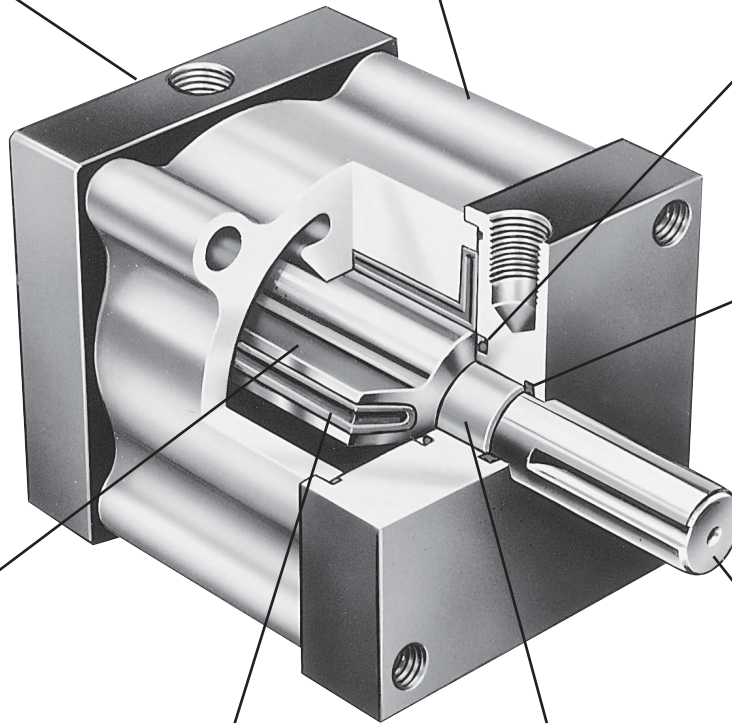
Solid stock heads are precision machined from aluminum, then hard-coat anodized and permanently sealed to ensure long seal life and low breakaway pressure. Solid stock heads eliminate cavities where contaminants may collect and also allow rear porting.

**BODY**

The precision body extrusion is hard-coat anodized and permanently sealed, resulting in a smooth, slick seal surface. This guarantees minimum breakaway and maximum seal life. The unitized body incorporates the stator(s) for superior rigidity.

**SHOULDER SEAL**

A nitrile energized, glass-filled PTFE seal is utilized. It reduces bypass flow and friction, providing superior performance and long life.



**VANE**

A hard-coat anodized, precision aluminum extrusion is permanently affixed to shaft. The lightweight vane reduces inertia allowing very fast rotational speeds.

**VANE SEAL**

A special self-lubricated, abrasion resistant nitrile compound is molded into a one-piece vane seal, providing low breakaway pressure and long life, even with no lubrication.

**SHAFT SEAL**

The high quality, self-lubricated, abrasion resistant nitrile seal is a multiple lobe construction for leak-free operation and greater reliability. (Cleanroom option available on sizes 22, 42, 44 and 46.)

**SHAFT**

Stainless steel provides high strength and corrosion resistance for demanding applications.

**SHAFT BEARING**

Thermoplastic journal bearing provides washdown capability and low cost. Optional radial ball bushing offers greater precision.

PV Series

PRN(A) Series

PTR Series

B671/F672 Series

HP Series

Rotary Actuators  
Products

**H**



For inventory, lead time, and kit lookup, visit [www.pdnplu.com](http://www.pdnplu.com)

H3

**Parker Hannifin Corporation**  
Pneumatic Division  
Richland, Michigan  
[www.parker.com/pneumatics](http://www.parker.com/pneumatics)

Features

- Single or double vane rotary actuator
- 8 model sizes
- Output torque @ 100 PSIG: 8 to 1800 lb-in
- Standard rotations:
  - Single vane units:  $280^\circ \pm 1^\circ$   
(except size 10 & 11:  $275^\circ \pm 2.5^\circ$ )
  - Double vane units:  $100^\circ \pm 1^\circ$   
(except size 10 & 11:  $95^\circ \pm 2.5^\circ$ )
- Available with stroke adjusters and internal stops to provide 90° and 180° rotation
- Stainless steel shaft
- Optional radial ball bushing shaft bearing



Operating information

Operating pressure:	150 PSIG (10.3 bar)
Temperature range: †	
Nitrile seals	30°F to 180°F (-1°C to 82°C)
Fluorocarbon seals*	30°F to 250°F (-1°C to 121°C)
* See fluorocarbon seal option for high temperature applications.	
† Flow low temperature version, please consult factory.	
Filtration requirements:	40 micron, dry filtered air

Ordering information



Model			
10	22	33	42
11		36	44
			46

Vanes / maximum rotation	
Omit	Single Vane, 280° Rotation (275° on PV10, PV11)
D	Double Vane, 100° Rotation (95° on PV10, PV11)

Special options	
Omit	Standard
Two digit code assigned by factory when any "X" appears in the model number or when special options or features are required.	

Design series	
B	Current design series

Rotation Options (may order more than one)	
Omit	Standard Units (no stroke adjusters, bumpers or switches)
090A	Stroke Adjusters adjustable from 60° to maximum unit rotation (preadjusted to 90°)*
180A	Stroke Adjusters (single vane only) adjustable from 60° to 190° (preadjusted to 180°)*
090B	Internal bumpers, 90° rotation <sup>4</sup>
180B	Internal bumpers, 180° rotation (single vane only)
090S	Magnets <sup>1</sup> added, 90° setting
180S	Magnets <sup>1</sup> added, 180° setting (single vane only)

\* Stroke adjusters cannot be ordered with bumpers

1. Switches can be used with stroke adjusters or bumpers (example: PV22D-090BS-BB2-B).
2. Not available with switches or stroke adjusters.
3. No tapped mounting holes in face opposite the flange.
4. 90° bumpers (090B) not available on PV10/11 sizes.

**Note:**  
Order Hall effect sensors and reed switches separately from the Electronic Sensors section.

Options	
Omit	None
L	Radial ball bushings
V	Fluorocarbon seals

Ports	
2	NPTF Top (Std) (10-32 on PV10 & PV11)
7	NPTF Rear <sup>2</sup> (10-32 on PV10 & PV11)

Shaft	
B	Single male keyed (Std)
C	Double end male keyed <sup>2</sup>

Mounting	
B	Base / Front (Std)
R	Rear Flange <sup>2,3</sup>
F	Front Flange
S	Base / Rear Face <sup>2</sup>

**Sensors**  
See section L for sensors.

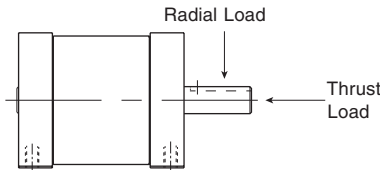


For inventory, lead times, and kit lookup, visit [www.pdnplu.com](http://www.pdnplu.com)



**Quick reference data**

Model number	Maximum rotation (Degrees)	Actual output torque (lb-in) at specified input pressure (PSI)			Displacement (in <sup>3</sup> )	Maximum breakaway pressure (PSI)	Maximum bypass leakage @100 psi (CFM)	Unit weight (lb)
		50	75	100				
10	275°	4	6	8	0.52	25	0.15	0.38
10D	95°	8	12	16	0.37	20	0.20	0.38
11	275°	8	12	16	1.04	20	0.15	0.50
11D	95°	17	25	33	0.74	15	0.20	0.50
22	280°	32	48	64	3.67	15	0.20	0.50
22D	100°	68	101	135	2.62	10	0.25	1.75
33	280°	75	112	150	8.70	15	0.20	3.44
33D	100°	155	235	315	6.20	10	0.25	3.56
36	280°	150	220	300	17.40	15	0.20	5.19
36D	100°	315	470	630	12.40	10	0.25	5.50
42	280°	140	210	285	17.80	15	0.20	7.13
42D	100°	300	450	600	14.58	10	0.25	7.50
44	280°	285	425	570	35.61	15	0.20	8.81
44D	100°	600	900	1200	29.17	10	0.25	9.38
46	280°	425	640	850	53.41	15	0.20	10.50
46D	100°	900	1350	1800	43.75	10	0.25	10.75

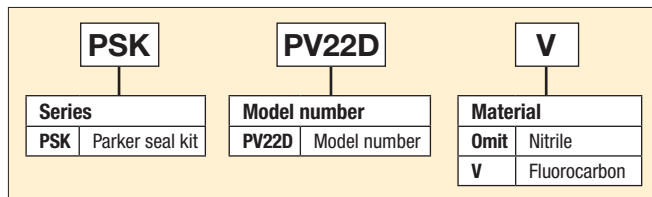


**Kinetic energy ratings and bearing load capacities**

Model number	Composite bushing load capacities (lb)*		Radial ball bushing load capacities (lb)*		Distance between centerline bearings	Maximum kinetic energy rating for models based on configuration (in-lb)		
	Radial	Thrust	Radial	Thrust		Standard	Stroke adjusters	Bumpers
10	15	7	50	15	0.88	0.03	0.12	0.05
11	15	7	50	15	1.50	0.06	0.12	0.09
22	50	25	Consult factory		2.38	0.25	0.50	0.38
33	100	50	Consult factory		3.50	0.75	1.50	1.13
36	100	50	Consult factory		6.50	1.00	1.50	1.50
42	200	75	Consult factory		2.75	2.00	4.00	3.00
44	200	75	Consult factory		4.75	2.50	4.00	3.75
46	200	75	Consult factory		6.75	3.00	4.00	4.75

\* Bearing capacities only. Check Kinetic Energy ratings to determine if actuator will stop load.

**Seal kit ordering information**



**Seal kit installation tool**

Model (S)	Items	Seal guide kit number
PV10 & 11 (D)	21, 22	ATS-PV1
PV22 (D)	21, 22	ATS-PV2
PV33 & 36 (D)	21, 22	ATS-PV3



For inventory, lead time, and kit lookup, visit [www.pdnplu.com](http://www.pdnplu.com)

PV Series  
 PRN(A) Series  
 PTR Series  
 B671/F672 Series  
 HP Series  
 Rotary Actuators Products



**Kinetic Energy Basic Formula**

$$KE = 1/2 Jm\omega^2$$

$$\omega = 0.035 \times \frac{\text{Angle Traveled (Deg.)}}{\text{Rotation Time (Sec.)}}$$

where:

KE = Kinetic Energy (in-lb)

Jm = Rotational mass moment of inertia (in-lb-sec<sup>2</sup>)

(Dependent on physical size of object and weight)

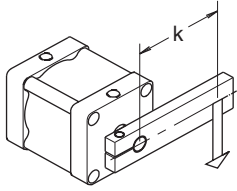
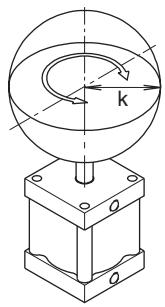
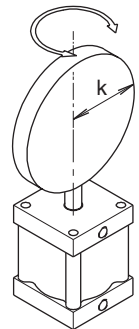
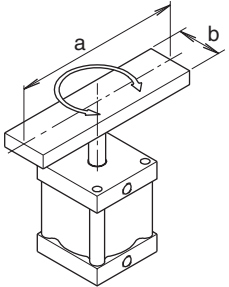
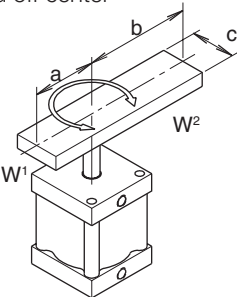
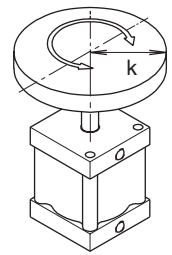
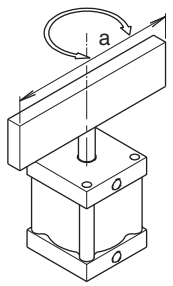
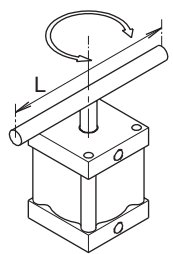
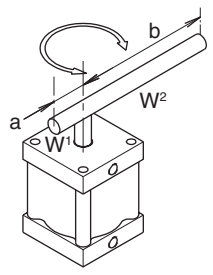
$\omega$  = Peak Velocity (rad/sec) (Assuming twice average velocity)

W = Weight of load (lb)

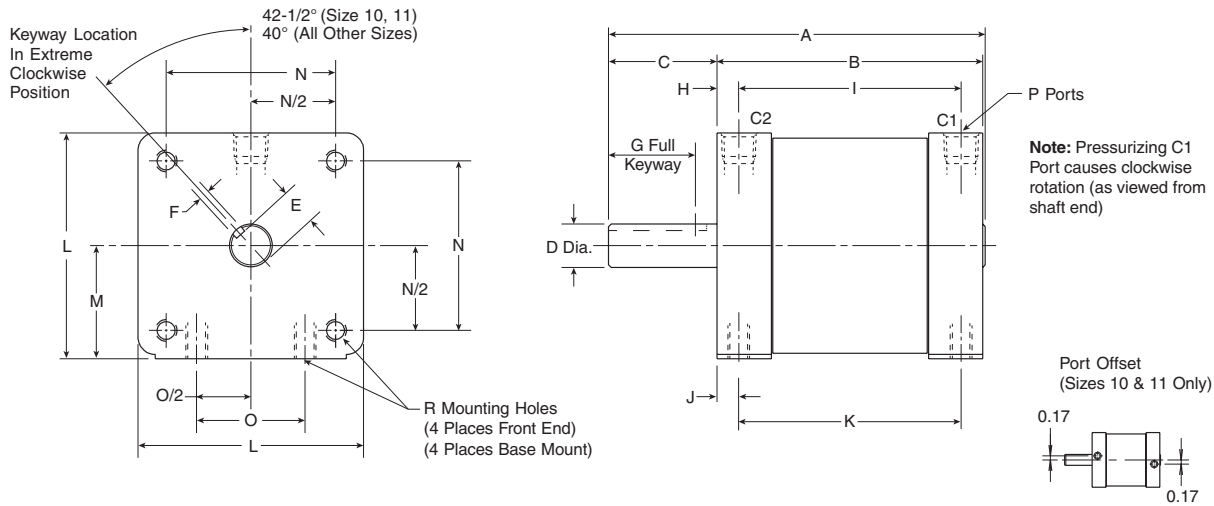
g = Gravitational constant = 386.4 in/sec<sup>2</sup>

k = Radius of gyration (in)

**Moments of Inertia**

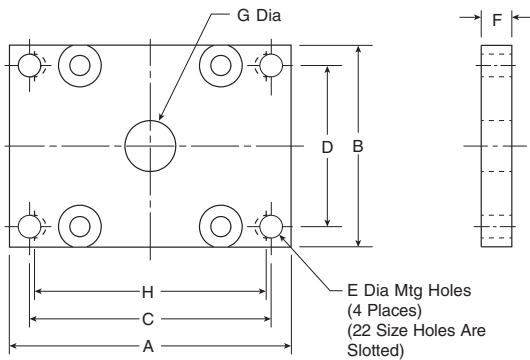
<p>POINT LOAD</p>  $Jm = \frac{W}{g} \times k^2$	<p>SOLID SPHERE - Mounted on center</p>  $Jm = \frac{2}{5} \times \frac{W}{g} \times k^2$	<p>THIN DISK - End mounted on center</p>  $Jm = \frac{W}{g} \times \frac{k^2}{4}$
<p>THIN RECTANGULAR PLATE - Mounted on center</p>  $Jm = \frac{W}{g} \times \frac{a^2 + b^2}{12}$	<p>THIN RECTANGULAR PLATE - Mounted off center</p>  $Jm = \frac{W^1}{g} \times \frac{4a^2 + c^2}{12} + \frac{W^2}{g} \times \frac{4b^2 + c^2}{12}$	<p>THIN DISK - Mounted on center</p>  $Jm = \frac{W}{g} \times \frac{k^2}{2}$
<p>THIN RECTANGULAR PLATE - End mounted on center</p>  $Jm = \frac{W}{g} \times \frac{a^2}{12}$	<p>SLENDER ROD - Mounted on center</p>  $Jm = \frac{W}{g} \times \frac{L^2}{12}$	<p>SLENDER ROD - Mounted off center</p>  $Jm = \frac{W^1}{g} \times \frac{a^2}{3} + \frac{W^2}{g} \times \frac{b^2}{3}$

**Standard Face/Base Mount (B) and Male Keyed Shaft (B)**



Model number	A	B	C	D	E	F	G	H	I	J	K	L	M	N	O	P	R
10	2.280	1.38	0.88	0.312 0.311	0.258 0.253	0.095 0.094	0.63	0.19	1.00	0.19	1.000	1.62	0.810	1.220	0.750	10-32	8-32 x 0.25 DP
11	2.905	2.00	0.88	0.312 0.311	0.258 0.253	0.095 0.094	0.63	0.19	1.63	0.19	1.625	1.62	0.810	1.220	0.750	10-32	8-32 x 0.25 DP
22	4.340	3.06	1.25	0.500 0.499	0.423 0.418	0.126 0.125	0.94	0.25	2.56	0.25	2.560	2.50	1.250	2.000	1.250	1/8 NPTF	1/4-20NC x 0.38 DP
33	6.180	4.40	1.75	0.749 0.748	0.644 0.639	0.189 0.188	1.38	0.35	3.70	0.26	3.875	3.00	1.500	2.436	1.500	1/4 NPTF	5/16-18NC x 0.47 DP
36	9.180	7.40	1.75	0.749 0.748	0.644 0.639	0.189 0.188	1.38	0.35	6.70	0.26	6.875	3.00	1.500	2.436	1.500	1/4 NPTF	5/16-18NC x 0.47 DP
42	6.280	4.00	2.25	0.999 0.998	0.859 0.854	0.251 0.250	2.00	0.50	3.00	0.50	3.000	4.50	2.250	3.500	2.375	1/4 NPTF	3/8-16NC x 0.75 DP
44	8.280	6.00	2.25	0.999 0.998	0.859 0.854	0.250 0.251	2.00	0.50	5.00	0.50	5.000	4.50	2.250	3.500	2.375	1/4 NPTF	3/8-16NC x 0.75 DP
46	10.280	8.00	2.25	0.999 0.998	0.859 0.854	0.250 0.251	2.00	0.50	7.00	0.50	7.000	4.50	2.250	3.500	2.375	1/4 NPTF	3/8-16NC x 0.75 DP

**Flange Mount (F, R)\***



Model number	A	B	C	D	E	F	G	H
10	2.50	1.62	2.000	1.250	0.203	0.19	0.41	N/A
11	2.50	1.62	2.000	1.250	0.203	0.19	0.41	N/A
22	3.50	2.50	3.000	2.000	0.281	0.25	0.66	2.875
33	4.50	3.00	3.750	2.000	0.344	0.38	0.84	N/A
36	4.50	3.00	3.750	2.000	0.344	0.38	0.84	N/A
42	7.32	4.51	5.905	2.953	0.551	0.63	1.61	N/A
44	7.32	4.51	5.905	2.953	0.551	0.63	1.61	N/A
46	7.32	4.51	5.905	2.953	0.551	0.63	1.61	N/A

**Note:** The face opposite the flange mount does not contain tapped mounting holes. Consult factory if needed.



For inventory, lead time, and kit lookup, visit [www.pdnplu.com](http://www.pdnplu.com)

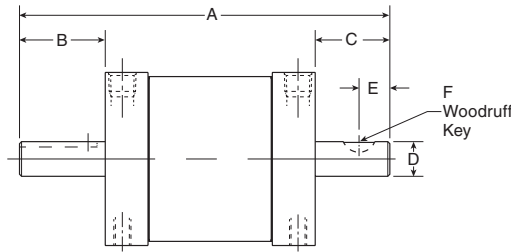
H7

**Parker Hannifin Corporation**  
 Pneumatic Division  
 Richland, Michigan  
[www.parker.com/pneumatics](http://www.parker.com/pneumatics)

PV Series  
 PRN(A) Series  
 PTR Series  
 B671/F672 Series  
 HP Series  
 Rotary Actuators Products



**Double End Male Keyed Shaft (C)**



**Note:** Not available with switches or stroke adjustment. Consult factory for rear port option.

Model number	A	B	C	D	E	F
10	2.75	0.88	0.50	0.312 0.311	0.28	#302.5
11	3.38	0.88	0.50	0.312 0.311	0.28	#302.5
22	5.06	1.25	0.75	0.500 0.499	0.44	#404
33	7.15	1.75	1.00	0.749 0.748	0.56	#606
36	10.15	1.75	1.00	0.749 0.748	0.56	#606
42	7.53	2.25	1.28	0.999 0.998	0.72	#808
44	9.53	2.25	1.28	0.999 0.998	0.72	#808
46	11.53	2.25	1.28	0.999 0.998	0.72	#808

**Adjustable Rotation Stop (090A, 180A)**

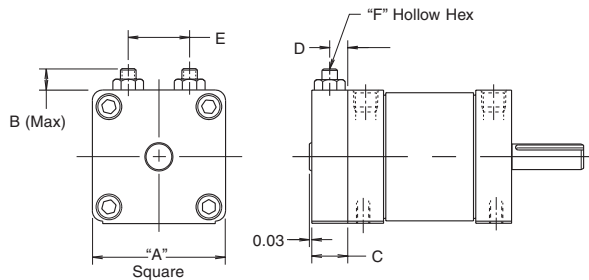
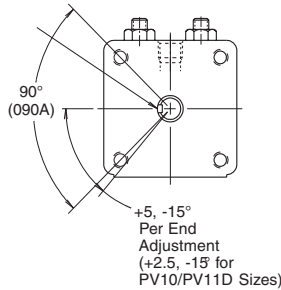
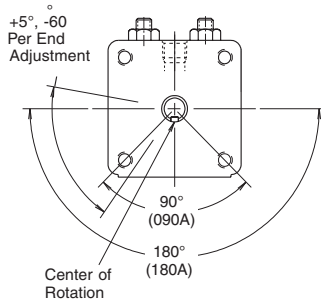
An adjustable positive stop is available to provide end of rotation adjustability in a compact package. Total adjustment range is 60° to 190° on single vane actuators, and 60° to 100° on double vane actuators (95° on PV10/11 sizes). The rotation is factory preset to a nominal 90° or 180° (090A or 180A) for convenient installation.

**NOTE:**

1. Not available with double end shaft.
2. Not available with rear ports.

**SINGLE VANE UNIT**

**DOUBLE VANE UNIT**

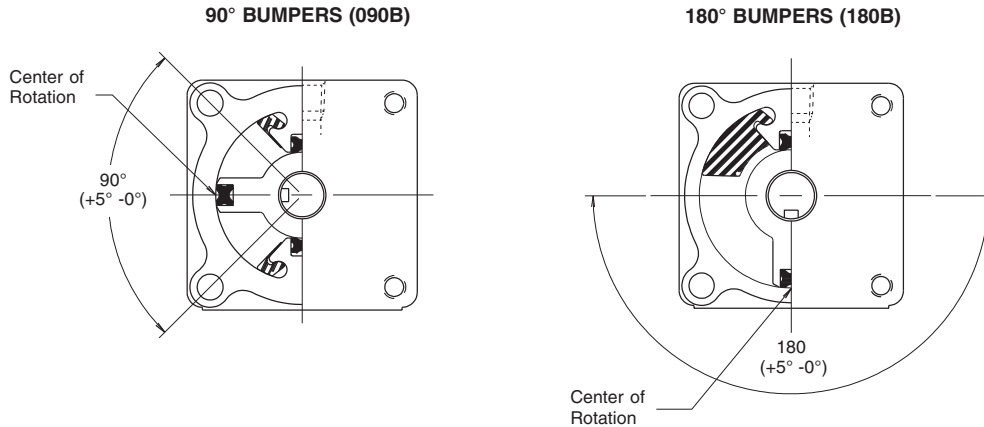


Model number	A	B	C	D	E	F
10	1.62	0.63	0.47	0.24	0.75	3/32
11	1.62	0.63	0.47	0.24	0.75	3/32
22	2.50	1.00	0.72	0.36	1.25	5/32
33	3.00	1.16	0.97	0.425	1.56	3/16
36	3.00	1.16	0.97	0.425	1.56	3/16
42	4.50	1.38	1.25	0.56	2.25	7/32
44	4.50	1.38	1.25	0.56	2.25	7/32
46	4.50	1.38	1.25	0.56	2.25	7/32

Options

90° or 180° Bumpers (090B, 180B)

Bumpers are available to reduce noise and dissipate energy. This permits faster cycle times and increased production rates. Single vane units are available with 90° or 180° bumpers and double vane units are available with 90° bumpers.



90° or 180° Magnet (S)

Option “S” provides a magnet(s) attached to the actuator shaft. Hall effect or reed switches sense the position of these magnets. The switches are available in two nominal rotations, 90° or 180°, and the adjustment is  $\pm 20^\circ$  for each switch to provide a total adjustment of  $\pm 40^\circ$ . Adjustable stops, “A”, or bumpers, “B”, can be supplied in addition to magnets. Order switches separately.

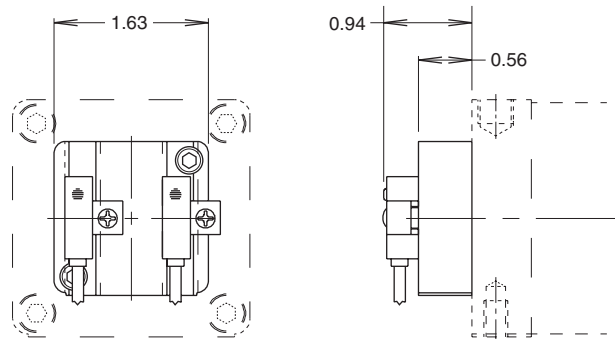
Example Ordering Codes, Keyway Positions and Switch Sensing Locations:

Please note the following keyway position and switch sensing locations, with respect to ordering codes and options, with porting at the 12:00 position as viewed from the output shaft end (as shipped from the factory).

**180S, 180AS, 180BS** - Single vane actuator with magnet or with magnet and stroke adjusters and/or bumpers: Keyway midstroke position at 6:00, magnet positioned to sense at 3:00 and 9:00.

**090S, 090AS** - Single vane actuator with magnet or with magnet and stroke adjusters: Keyway midstroke position at 6:00, magnet positioned to sense at 4:30 and 7:30.

**090S, 090AS, 090BS** - Double vane actuator with magnet or with magnet and stroke adjusters or bumpers; or single vane actuator with magnet and bumpers: Keyway midstroke position at 9:00, magnet positioned to sense at 7:30 and 10:30.



PV Series
PRN(A) Series
PTR Series
B671/F672 Series
HP Series
Rotary Actuators Products



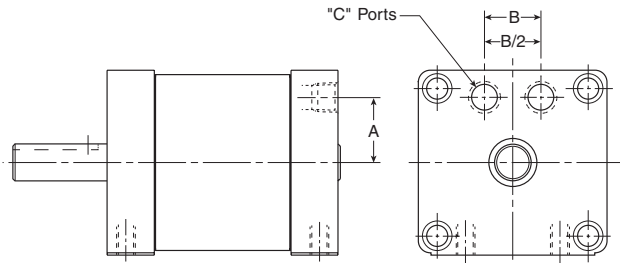
For inventory, lead time, and kit lookup, visit [www.pdnplu.com](http://www.pdnplu.com)

Options

Rear Port (7)

Rear porting provides convenience for confined mounting on very small units being face mounted.

This option is not available with switches or stroke adjustment. Consult factory for double end shaft option.

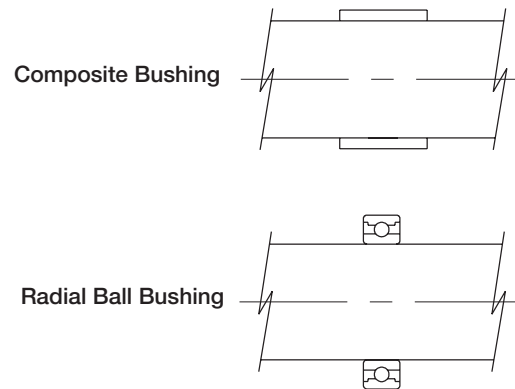


Model number	A	B	C
10	0.54	0.50	10-32
11	0.54	0.50	10-32
22	0.88	0.75	1/8 NPTF
33	1.09	0.90	1/8 NPTF
36	1.09	0.90	1/8 NPTF
42	1.68	1.00	1/4 NPTF
44	1.68	1.00	1/4 NPTF
46	1.68	1.00	1/4 NPTF

Bearings - Radial Ball Bushings (L)

Composite bushings should be used for washdown, highly contaminated, and low priced applications. Radial ball bushings provide greater precision. For bearing load capacities, reference the Engineering Data section of the catalog.

Consult factory for pricing and availability.



Fluorocarbon Seals (V)

Standard self-lubricating, abrasion resistant nitrile seals should be used for general purpose applications with temperatures of 0 to 180°F. Fluorocarbon seals are recommended for high temperature applications up to 250°F.

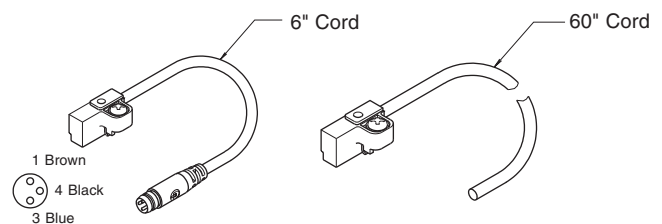
Option	Temperature Range* (°F)
Bumpers	0 - 200
Magnets	0 - 155
Switches	14 - 185

\*Consult factory for higher temperature operation.

Solid State (Hall Effect) and Reed Sensors

Sensors are available in a normally open or normally closed configuration. The low amp reed sensor is suitable for connection to PLCs or other low current devices. The high amp sensor can be used to drive sequencers, relays, coils or other devices directly.

Sensors must be ordered separately from the Electronic Sensors section.

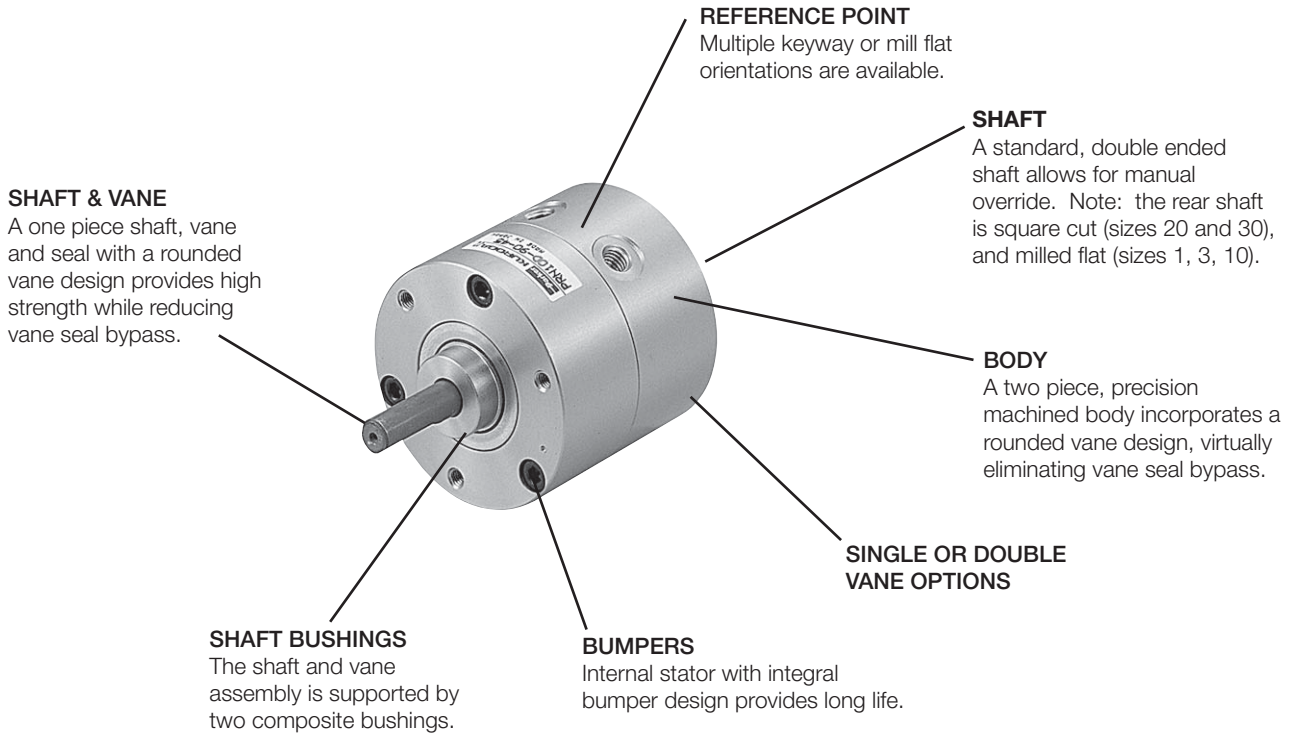


For inventory, lead times, and kit lookup, visit [www.pdnplu.com](http://www.pdnplu.com)

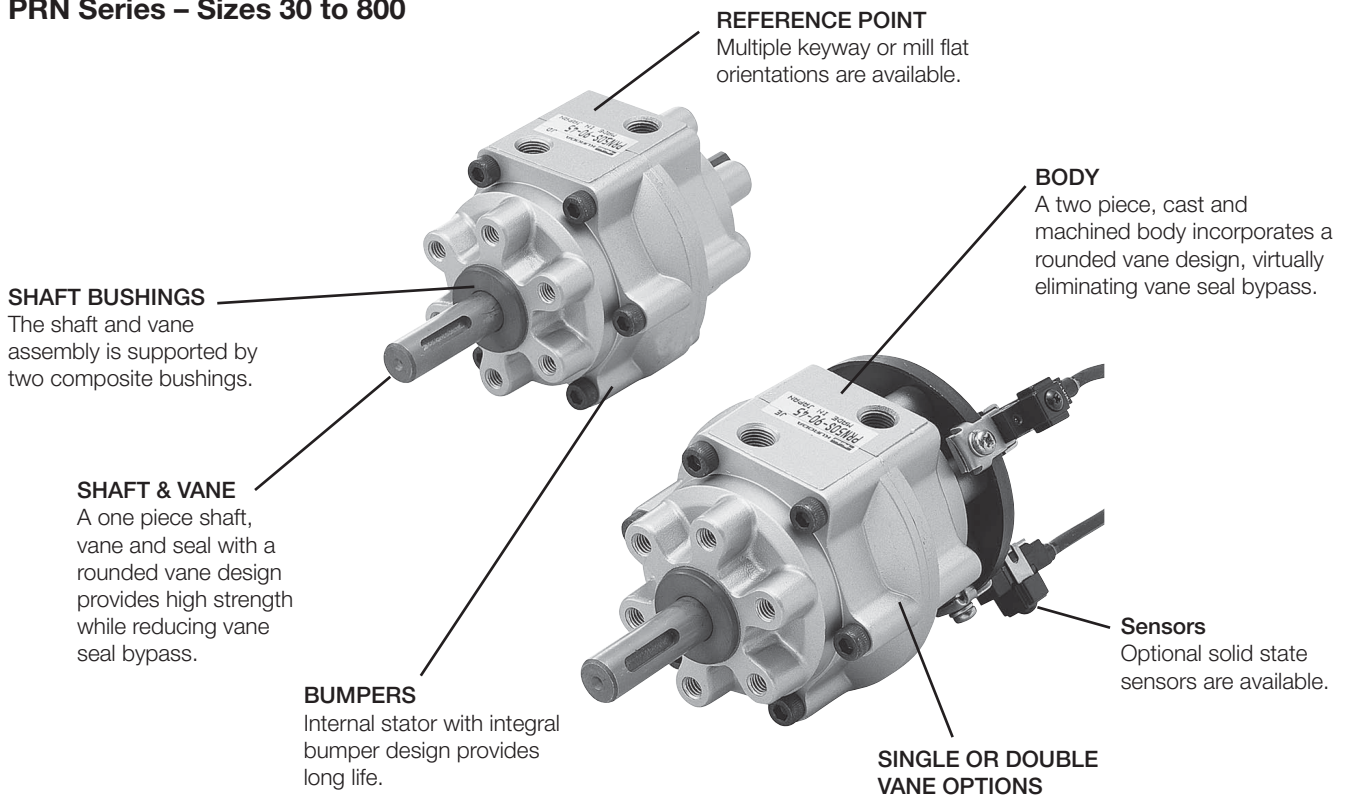
PV Series
PRN(A) Series
PTR Series
B671/F672 Series
HP Series
Rotary Actuators Products
<b>H</b>

**PRN Series**

**PRNA Series – Miniature Sizes 1 to 20**



**PRN Series – Sizes 30 to 800**



For inventory, lead time, and kit lookup, visit [www.pdnplu.com](http://www.pdnplu.com)

Features

- Single or double vane rotary actuator
- 3 standard rotations: 90°, 180°, or 270°
- Output torque @ 0.7 MPa:  
16 to 1120 N•cm (1.4 to 99 in-lb)
- Internal bumpers are standard
- Shock absorbers are available for high inertia loads



Operating information

Operating pressure:	100 PSIG (6.9 bar)
Temperature range:	-5°C to 80°C (-23°F to 176°F)
Filtration requirements:	40 micron, dry filtered air

Ordering information

**PRNA**      **20**      **S** - **90** - **90**      **S**

Type	
PRNA	Sizes 1-20
PRN	Sizes 30-800

Size
1
3
10
20
30
50
150
300
800

Type	
S	Single vane
D	Double vane

Porting	
Omit	Standard porting
S	Rear porting (sizes 3-20 only)

Rotation angle	
90	90° (all sizes, single and double vane)
100	100° (sizes 50 through 800, double vane only)
180	180° (all sizes, single vane only)
270	270° (single vane only, not available on size 1)
280	280° (sizes 50 through 800, single vane only)

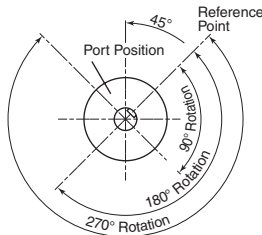
Oscillating reference point*	
40	40°
45	45°
90	90°

\* See specification tables for availability of rotation angle /reference point combinations for the selected model.

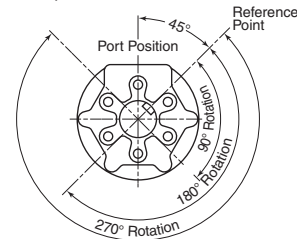
**Sensors**  
See section L for sensors.

Reference point and rotation orientations

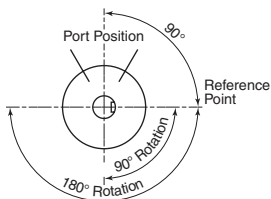
**PRNA1S/D, PRNA3S/D, PRNA10S/D PRNA20S/D, PRN30S/D**  
Reference point at 45°



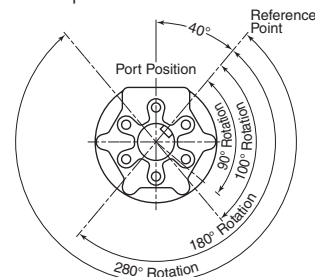
**PRN50, 150, 300, 800**  
Reference point at 45°



**PRN1AS, PRNA3S PRNA10S, PRNA20S**  
Reference point at 90°



**PRN50, 150, 300, 800**  
Reference point at 40°



For inventory, lead times, and kit lookup, visit [www.pdnplu.com](http://www.pdnplu.com)



Quick reference data – PRNA miniature

Type	Model number	Theoretical output torque								Maximum breakaway pressure		Unit weight	
		0.3 MPa (45 PSI)		0.5 MPa (75 PSI)		0.7 MPa (100 PSI)		1.0 MPa (145 PSI)					
		Ncm	(in-lb)	Ncm	(in-lb)	Ncm	(in-lb)	Ncm	(in-lb)	MPa	PSI	kg	lb
Single vane	PRNA1S	8	(0.7)	13	(1.2)	19	(1.6)	—	—	0.08	(12)	0.04	(0.08)
	PRNA3S	17	(1.5)	31	(3)	45	(4.0)	—	—	0.10	(15)	0.07	(0.15)
	PRNA10S	46	(4.1)	86	(7.6)	127	(11)	—	—	0.10	(15)	0.14	(0.31)
	PRNA20S	80	(7.1)	159	(14)	240	(21)	350	(31)	0.10	(15)	0.25	(0.55)
Double vane	PRNA1D	17	(1.5)	28	(2.5)	41	(3.6)	—	—	0.10	(15)	0.04	(0.09)
	PRNA3D	32	(2.9)	54	(4.8)	76	(6.7)	—	—	0.07	(10)	0.07	(0.16)
	PRNA10D	101	(8.9)	168	(15)	235	(21)	—	—	0.07	(10)	0.15	(0.33)
	PRNA20D	165	(15)	330	(29)	530	(47)	800	(71)	0.06	(9)	0.26	(0.57)

Kinetic energy ratings and bearing load capacities – sizes 1 to 30

Model number	Bearing load capacities				Distance between centerline bearings		Maximum kinetic energy rating	
	Thrust load		Radial load		mm	in	mJ	in-lb
	N	lb	N	lb				
PRNA1S	1	0.2	10	2	15	0.6	0.8	0.01
PRNA3S	4	0.9	40	9	20	0.8	4	0.03
PRNA10S	4	0.9	50	11	30	1.2	8	0.07
PRNA20S	25	5.6	300	67	42	1.7	40	0.35
PRN30S	30	6.7	400	90	48	1.9	67	0.60

Specifications

Model	Unit	PRNA1S			PRNA3S			PRNA10S			PRNA20S			PRN30S		
Vane		Single Vane														
Rotation	Degree	90	180	270	90	180	270	90	180	270	90	180	270	90	180	270
Rotational Tolerance	Degree	+4, -0														
Reference Point	Degree	90	90	90	45,90	45,90	45	45,90	45,90	45	45,90	45,90	45	45	45	45
Port Size		M5			M5			M5			M5			Rc 1/8		
Operating Pressure Range	MPa	0.3 to 0.7			0.2 to 0.7			0.2 to 0.7			0.2 to 1			0.2 to 1		
	psi	45 to 100			30 to 100			30 to 100			30 to 150			30 to 150		
Temperature Range	°C	-5 to 80			-5 to 80			-5 to 80			-5 to 80			-5 to 60		
	°F	23 to 176			23 to 176			23 to 176			23 to 176			23 to 140		
Maximum Frequency*	cycle/min	300	180	70	260	160	60	240	150	100	210	120	60	180	90	60
Displacement	cm <sup>3</sup>	1.4	1.4	1.5	3.4	3.4	4	9.8	9.8	12	17	17	21	37	37	43
	in <sup>3</sup>	0.09	0.09	0.09	0.2	0.2	0.2	0.6	0.6	0.7	1.0	1.0	1.3	2.3	2.3	2.6

Model	Unit	PRNA1D			PRNA3D			PRNA10D			PRNA20D			PRN30D		
Vane		Double Vane														
Rotation	Degree	90			90			90			90			90		
Rotational Tolerance	Degree	+4, -0			+4, -0			+4, -0			+4, -0			+4, -0		
Reference Point	Degree	45			45			45			45			45		
Port Size		M5			M5			M5			M5			Rc 1/8		
Operating Pressure Range	MPa	0.3 to 0.7			0.2 to 0.7			0.2 to 0.7			0.2 to 1			0.2 to 1		
	psi	45 to 100			30 to 100			30 to 100			30 to 150			30 to 150		
Temperature Range	°C	-5 to 80			-5 to 80			-5 to 80			-5 to 80			-5 to 60		
	°F	23 to 176			23 to 176			23 to 176			23 to 176			23 to 140		
Maximum Frequency*	cycle/min	240			240			240			200			200		
Displacement	cm <sup>3</sup>	2			2.4			5			10			34		
	in <sup>3</sup>	0.12			0.1			0.3			0.6			2.1		

\* Maximum frequency value given at a pressure of 0.5 MPa (73 psi) and under no load.



For inventory, lead time, and kit lookup, visit [www.pdnplu.com](http://www.pdnplu.com)

H13

**Parker Hannifin Corporation**  
Pneumatic Division  
Richland, Michigan  
[www.parker.com/pneumatics](http://www.parker.com/pneumatics)

PV Series  
PRN(A) Series  
PTR Series  
B671/F672 Series  
HP Series  
Rotary Actuators Products



**Quick reference data – PRN**

Type	Model number	Theoretical output torque								Maximum breakaway pressure		Unit weight	
		0.3 Mpa (45 PSI)		0.5 MPa (75 PSI)		0.7 MPa (100 PSI)		1.0 MPa (145 PSI)		MPa	PSI	kg	(lb)
Single vane	<b>PRN30S</b>	180	(16)	319	(28)	480	(42)	720	(64)	0.10	(15)	0.47	(1.04)
	<b>PRN50S</b>	259	(23)	479	(42)	700	(62.0)	1060	(94)	0.10	(15)	0.8	(1.8)
	<b>PRN150S</b>	850	(75)	1500	(133)	2100	(186)	3050	(270)	0.08	(12)	2.0	(4.4)
	<b>PRN300S</b>	1650	(146)	2850	(252)	4050	(358)	5750	(509)	0.08	(12)	3.7	(8.2)
Double vane	<b>PRN800S</b>	5910	(523)	10200	(903)	14400	(1274)	20500	(1814)	0.05	(7)	13	(28)
	<b>PRN30D</b>	440	(39)	770	(68)	1120	(99)	1660	(147)	0.08	(12)	0.48	(1.06)
	<b>PRN50D</b>	579	(51)	1040	(92.0)	1510	(134)	2250	(199)	0.08	(12)	0.8	(1.8)
	<b>PRN150D</b>	1900	(168)	3500	(310)	4800	(425)	6900	(611)	0.06	(9)	2.0	(4.4)
	<b>PRN300D</b>	3900	(345)	6800	(602)	9700	(858)	1370	(121)	0.06	(9)	4.3	(9.5)
	<b>PRN800D</b>	12000	(1062)	20600	(1823)	28800	(2549)	41100	(3637)	0.05	(7)	13	(28)

**Kinetic energy ratings and bearing load capacities – sizes 50 to 800**

Model	Bearing load capacities						Maximum kinetic energy rating					
	Thrust load		Radial load		Distance between centerline bearings		Standard unit		Shock absorber (per cycle)		Shock absorber (per cycle)	
	N	lb	N	lb	mm	in	J	in-lb	J	in-lb	J/hr	in-lb/hr
<b>PRN50S/D</b>	44.1	9.9	588	132	66	2.6	0.13	1.2	7.8	69	3100	27000
<b>PRN150S/D</b>	88.2	19.8	1176	264	79.5	3.1	0.6	5.3	10	231	11300	100000
<b>PRN300S/D</b>	147	33.0	1960	441	97.5	3.8	8.0	70	20	462	22000	194000
<b>PRN800S/D</b>	490	110.2	4900	1102	138.5	5.5	10.5	92	156	1387	56500	500000

**Specifications**

Model	Unit	PRN50S				PRN150S				PRN300S			
Vane		Double Vane											
Rotation	Degree	90	180	270	280	90	180	270	280	90	180	270	280
Rotational Tolerance	Degree	+3 -0											
Reference Point	Degree	45	40, 45	45	40	45	40, 45	45	40	45	40, 45	45	40
Port Size		Rc 1/8	Rc 1/8	Rc 1/8	Rc 1/8	Rc 1/4	Rc 1/4	Rc 1/4	Rc 1/4	Rc 3/8	Rc 3/8	Rc 3/8	Rc 3/8
Operating Pressure Range	MPa	0.2 to 1.0											
	psi	30 to 150											
Temperature Range	°C	5 to 60											
	°F	41 to 140											
Maximum Frequency*	cycle/min	180	90	60	60	120	80	50	50	90	60	40	40
Displacement	cm³	51	51	61	62	146	146	179	185	244	283	352	365
	in³	3.1	3.1	3.7	3.8	8.9	8.9	10.9	11.3	14.9	17	21	22

Model	Unit	PRN800S				PRN50D		PRN150D		PRN300D		PRN800D	
Vane		Double Vane											
Rotation	Degree	90	180	270	280	90	100	90	100	90	100	90	100
Rotational Tolerance	Degree	+3, -0											
Reference Point	Degree	45	40, 45	45	40	40, 45	40	45	40	45	40, 45	45	40
Port Size		Rc 1/2	Rc 1/2	Rc 1/2	Rc 1/2	Rc 1/8	Rc 1/8	Rc 1/4	Rc 1/4	Rc 3/8	Rc 3/8	Rc 1/2	Rc1/2
Operating Pressure Range	MPa	0.2 to 1.0											
	psi	30 to 150											
Temperature Range	°C	5 to 60											
	°F	41 to 140											
Maximum Frequency*	cycle/min	65	45	30	30	180	–	120	–	90	–	65	–
Displacement	cm³	754	869	1036	1046	42	43	127	123	244	271	754	774
	in³	46	53	63	64	2.6	2.6	7.7	7.5	14.9	16.5	46	47

\* Maximum frequency value given at a pressure of 0.5 MPa (73 psi) and under no load.

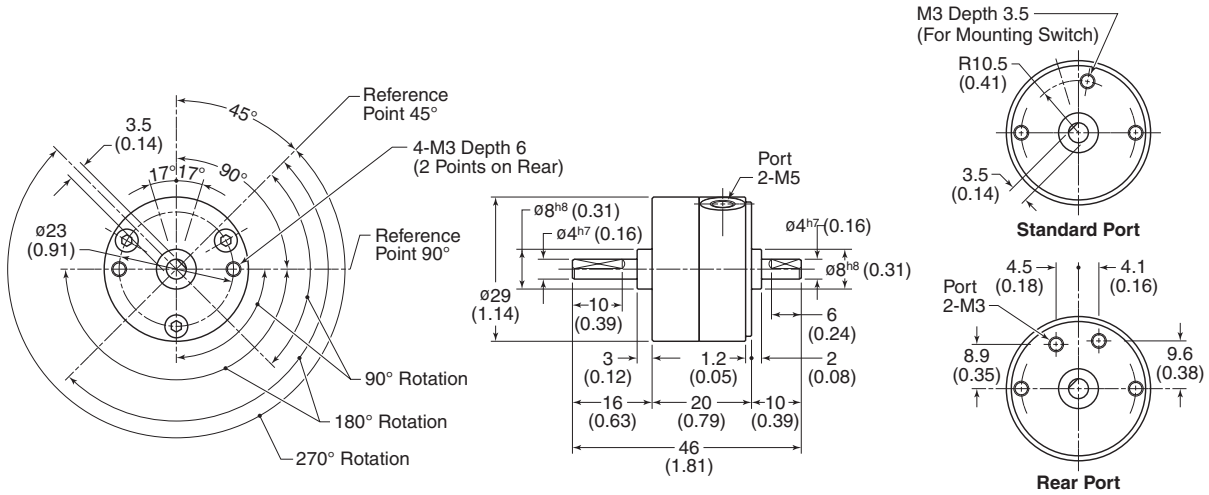


For inventory, lead times, and kit lookup, visit [www.pdnplu.com](http://www.pdnplu.com)

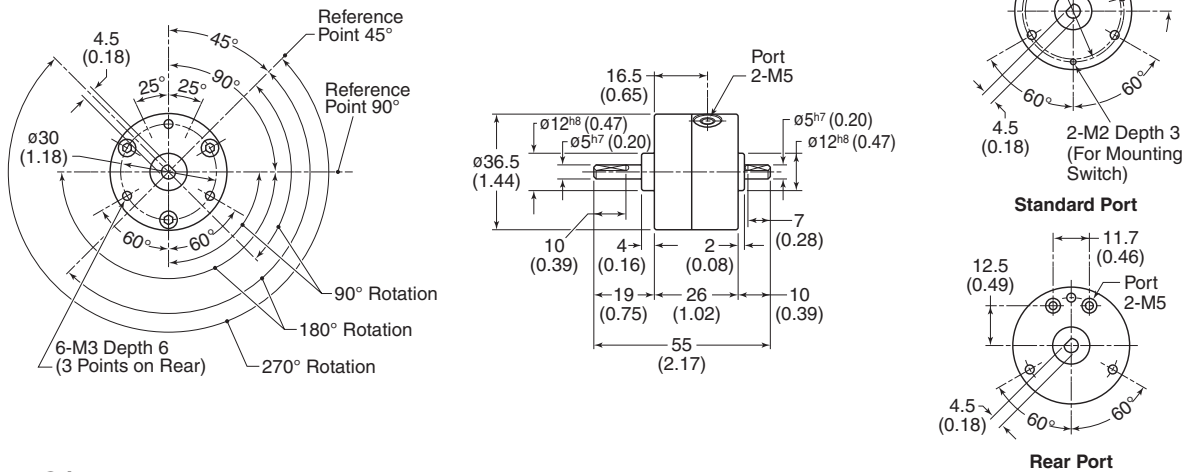
H14

**Parker Hannifin Corporation**  
Pneumatic Division  
Richland, Michigan  
[www.parker.com/pneumatics](http://www.parker.com/pneumatics)

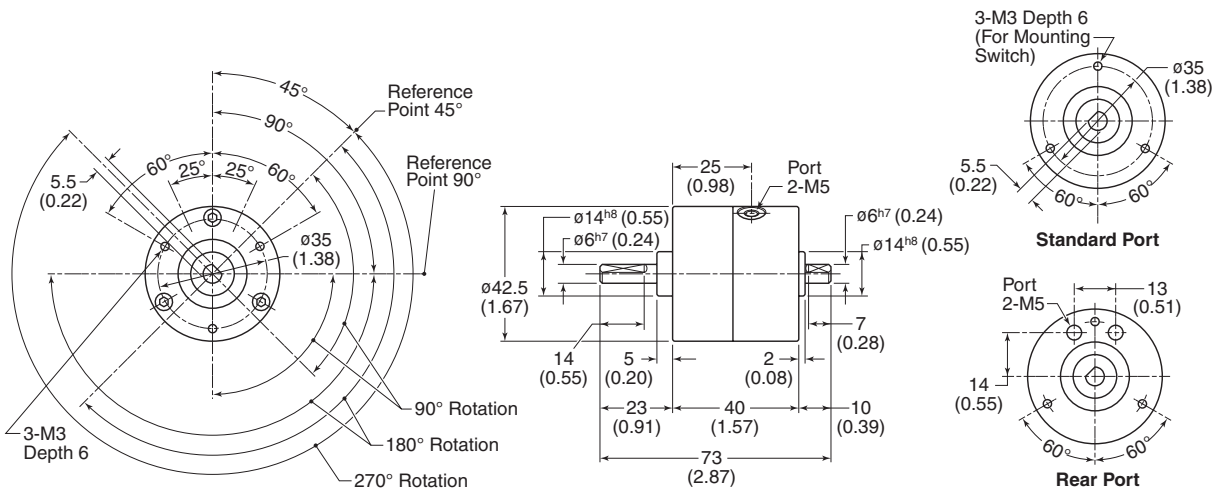
PRNA1S



PRNA3S/D



PRNA10S/D



Dimensions in mm (inch)

PV Series

PRNA(A) Series

PTR Series

B671/F672 Series

HP Series

Rotary Actuators Products



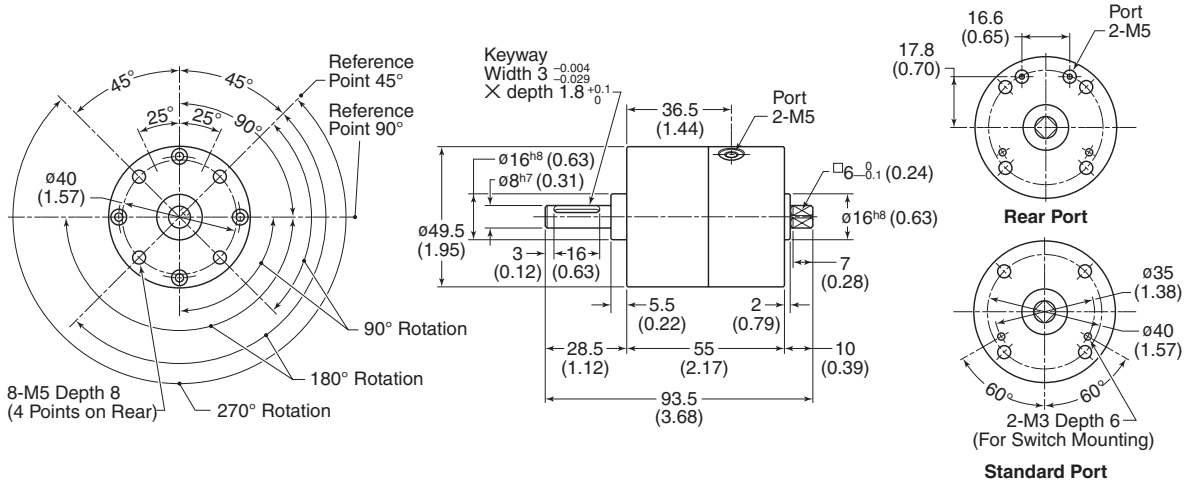
For inventory, lead time, and kit lookup, visit [www.pdnplu.com](http://www.pdnplu.com)

H15

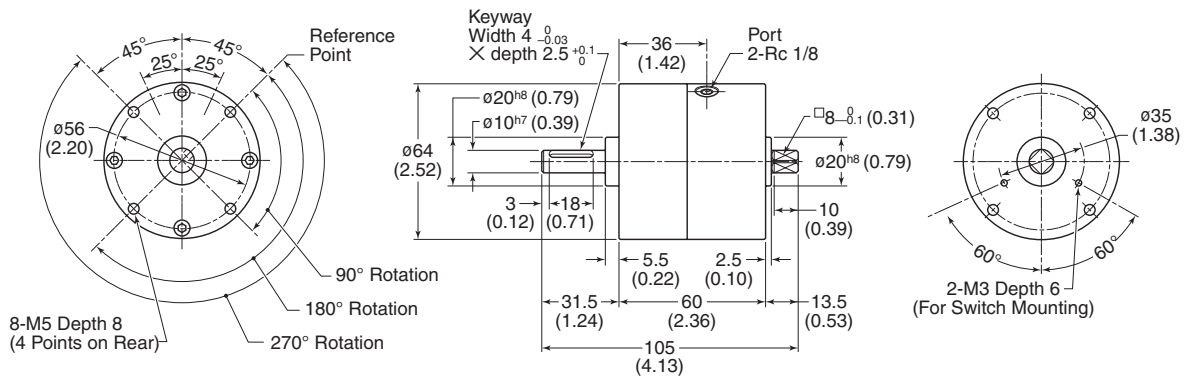
[www.comoso.com](http://www.comoso.com)

Parker Hannifin Corporation  
Pneumatic Division  
Richland, Michigan  
[www.parker.com/pneumatics](http://www.parker.com/pneumatics)

PRNA20S/D



PRN30S/D



Dimensions in mm (inch)

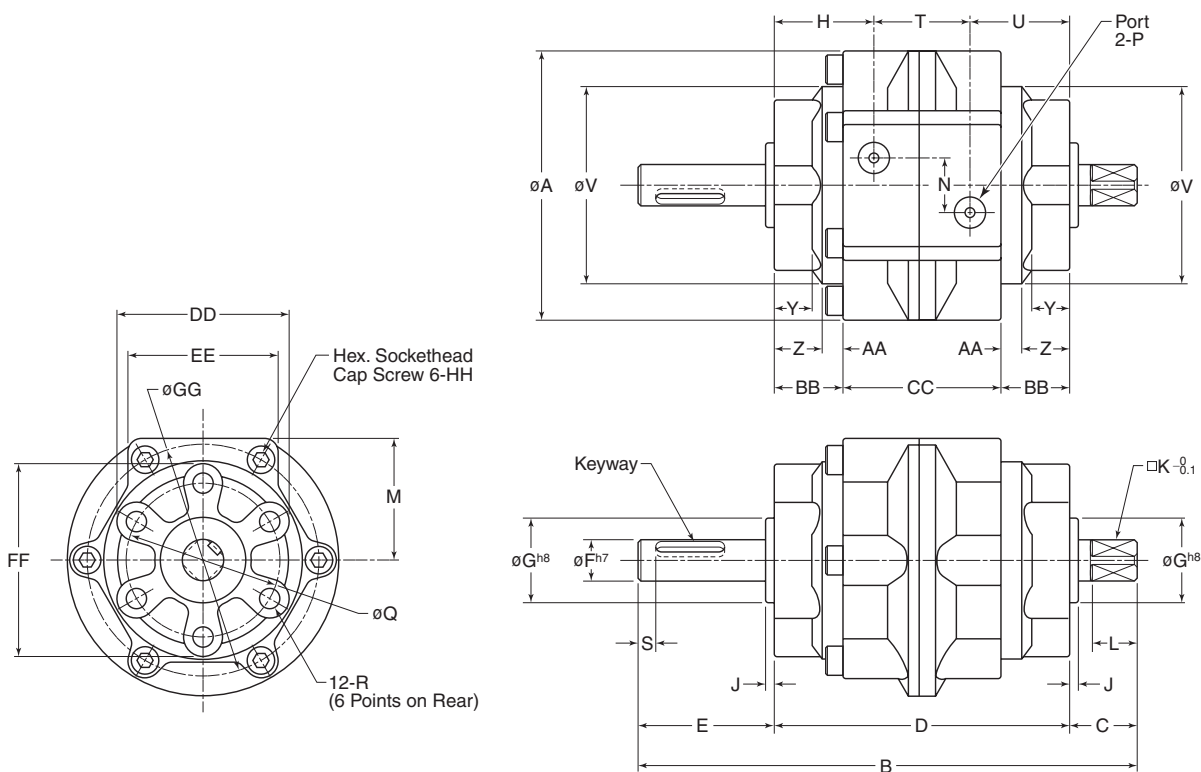


For inventory, lead times, and kit lookup, visit [www.pdnplu.com](http://www.pdnplu.com)

H16

**Parker Hannifin Corporation**  
Pneumatic Division  
Richland, Michigan  
[www.parker.com/pneumatics](http://www.parker.com/pneumatics)

PRN Sizes 50 to 800



Model number	A	B	C	D	E	F	G	H	J	K	L	M	N	P	Q	R	S
PRN50	79 (3.11)	145 (5.71)	19.5 (0.77)	86 (3.39)	39.5 (1.56)	12 (0.47)	25 (0.98)	29 (1.14)	2.5 (0.10)	10 (0.39)	13 (0.51)	36 (1.42)	16 (0.63)	Rc1/8	45 (1.77)	M6 x 1, Depth 9	5 (0.20)
PRN150	110 (4.33)	180 (7.09)	23.5 (0.93)	103 (4.06)	53.5 (2.11)	17 (0.67)	30 (1.18)	34.5 (1.36)	3 (0.12)	13 (0.51)	16 (0.63)	51 (2.01)	24 (0.94)	Rc1/4	70 (2.76)	M8 x 1.25, Depth 12	5 (0.20)
PRN300	141.5 (5.57)	220 (8.66)	30 (1.18)	125 (4.92)	65 (2.56)	25 (0.98)	45 (1.77)	41.5 (1.63)	3.5 (0.14)	19 (0.75)	22 (0.87)	66 (2.60)	32 (1.26)	Rc3/8	80 (3.15)	M10 x 1.5, Depth 15	5 (0.20)
PRN800	196 (7.72)	285 (11.22)	44.5 (1.75)	171 (6.73)	69.5 (2.74)	40 (1.57)	70 (2.76)	53.5 (2.11)	4.5 (0.18)	32 (1.26)	35 (1.38)	90 (3.54)	44 (1.73)	Rc1/2	120 (4.72)	M12 x 1.75, Depth 18	10 (0.39)

Model number	T	U	V	Y	Z	AA	BB	CC	DD	EE	FF	GG	HH	Keyway width x depth x length
PRN50	28 (1.10)	29 (1.14)	58 (2.28)	11 (0.43)	14 (0.55)	6 (0.24)	20 (0.79)	46 (1.81)	51 (2.01)	44 (1.73)	57 (2.24)	68 (2.68)	M5 x 30	4 <sup>0</sup> <sub>-0.03</sub> x 2.5 <sup>+0.1</sup> <sub>0</sub> x 20
PRN150	34 (1.34)	34.5 (1.36)	85.2 (3.35)	10.5 (0.41)	15.5 (0.61)	8 (0.31)	23.5 (0.93)	56 (2.20)	75 (2.95)	61 (2.40)	85 (3.35)	97 (3.82)	M6 x 35	5 <sup>0</sup> <sub>-0.03</sub> x 3 <sup>+0.1</sup> <sub>0</sub> x 36
PRN300	42 (1.65)	41.5 (1.63)	110 (4.33)	13 (0.51)	17.5 (0.69)	10 (0.39)	27.5 (1.08)	70 (2.76)	88.5 (3.48)	78 (3.07)	98.5 (3.88)	125 (4.92)	M8 x 45	7 <sup>0</sup> <sub>-0.03</sub> x 4 <sup>+0.1</sup> <sub>0</sub> x 40
PRN800	64 (2.52)	53.5 (2.11)	152 (5.98)	14.5 (0.57)	21.1 (0.83)	11.4 (0.45)	32.5 (1.28)	106 (4.17)	130 (5.12)	110 (4.33)	145 (5.71)	173 (6.81)	M12 x 70	12 <sup>0</sup> <sub>-0.043</sub> x 5 <sup>+0.2</sup> <sub>0</sub> x 40

mm (inch)

PV Series  
PRN(A) Series  
PTR Series  
B671/F672 Series  
HP Series  
Rotary Actuators Products



For inventory, lead time, and kit lookup, visit [www.pdnplu.com](http://www.pdnplu.com)

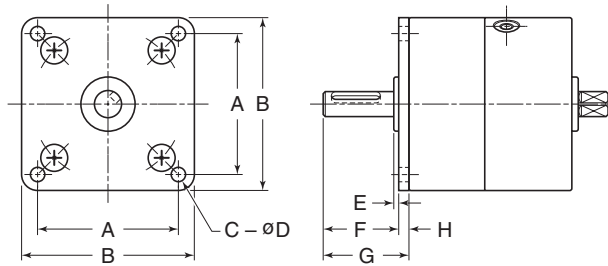
H17

Parker Hannifin Corporation  
Pneumatic Division  
Richland, Michigan  
[www.parker.com/pneumatics](http://www.parker.com/pneumatics)

Options – Sizes 1 to 30

Flange Mount – Sizes 1 to 30

**Note:** Should not be used on rear face when rear ports (S) or switches are specified.

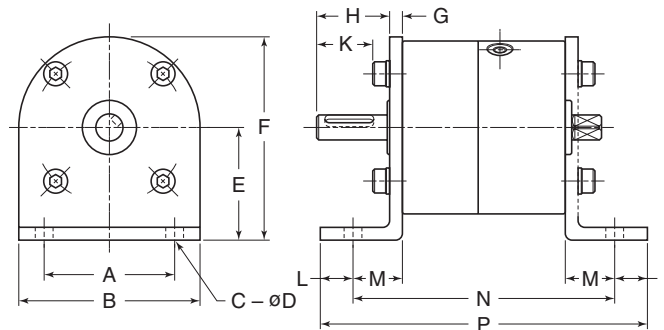


Part number	A	B	C	D	E	F	G	H
PRNA1-P	24 (0.94)	30 (1.18)	4 (0.16)	3.4 (0.13)	1 (0.04)	14 (0.55)	16 (0.63)	2 (0.08)
PRNA3-P	30 (1.18)	37 (1.46)	4 (0.16)	3.4 (0.13)	1.5 (0.06)	16.5 (0.65)	19 (0.75)	2.5 (0.10)
PRNA10-P	34 (1.34)	42 (1.65)	4 (0.16)	3.5 (0.14)	1.8 (0.07)	19.8 (0.78)	23 (0.91)	3.2 (0.13)
PRNA20-P	41 (1.61)	50 (1.97)	4 (0.16)	5.5 (0.22)	1.9 (0.07)	24.9 (0.98)	28.5 (1.12)	3.6 (0.14)
PRN30-P	52 (2.05)	64 (2.52)	4 (0.16)	5.5 (0.22)	1.9 (0.07)	27.9 (1.10)	31.5 (1.24)	3.6 (0.14)

mm (Inches)

Foot Mount – Sizes 1 to 30

- Note:**
- A foot plate can be rotated in intervals of 90°.
  - Only one plate included. Two plates must be purchased to mount from both sides (as shown).
  - Should not be used on rear face when rear ports (S) or switches are specified.



Part number	A	B	C	D	E	F	G	H	K	L	M	N	P
PRNA1-L	20 (0.79)	30 (1.18)	2 (0.08)	4.8 (0.19)	22 (0.87)	37 (1.46)	2 (0.08)	14 (0.55)	10.3 (0.41)	5 (0.20)	10 (0.39)	40 (1.57)	50 (1.97)
PRNA3-L	26 (1.02)	36 (1.41)	2 (0.08)	4.8 (0.19)	25 (0.98)	43 (1.69)	2.6 (0.10)	16.4 (0.65)	12.7 (0.50)	7 (0.28)	11 (0.43)	48 (1.89)	62 (2.44)
PRNA10-L	30 (1.18)	42 (1.65)	2 (0.08)	5.8 (0.23)	30 (1.18)	51 (2.01)	3.2 (0.13)	19.8 (0.78)	16.1 (0.63)	8 (0.31)	12 (0.47)	64 (2.52)	80 (3.15)
PRNA20-L	36 (1.42)	49 (1.93)	2 (0.08)	7 (0.28)	34 (1.34)	58.5 (2.30)	3.6 (0.14)	24.9 (0.98)	18.6 (0.73)	10 (0.39)	15 (0.59)	85 (3.35)	105 (4.13)
PRN30-L	48 (1.89)	66 (2.60)	2 (0.08)	6.5 (0.26)	42 (1.65)	75 (2.95)	4.5 (0.18)	27 (1.06)	20.7 (0.81)	12 (0.47)	18 (0.71)	96 (3.78)	120 (4.72)

mm (Inches)



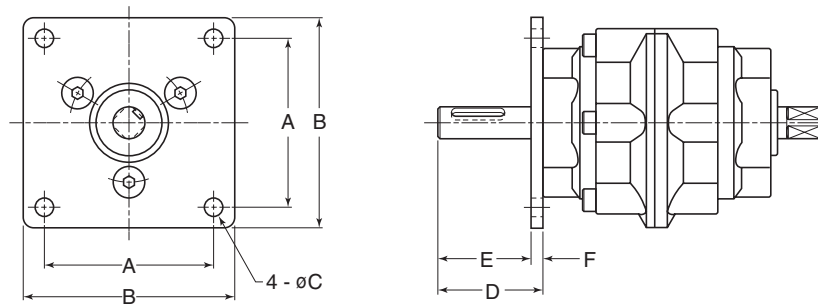
For inventory, lead times, and kit lookup, visit [www.pdnplu.com](http://www.pdnplu.com)

H18

**Parker Hannifin Corporation**  
Pneumatic Division  
Richland, Michigan  
[www.parker.com/pneumatics](http://www.parker.com/pneumatics)

**Flange Mount – Sizes 50 and 150**

**Note:** A flange plate can be rotated in intervals of 60°



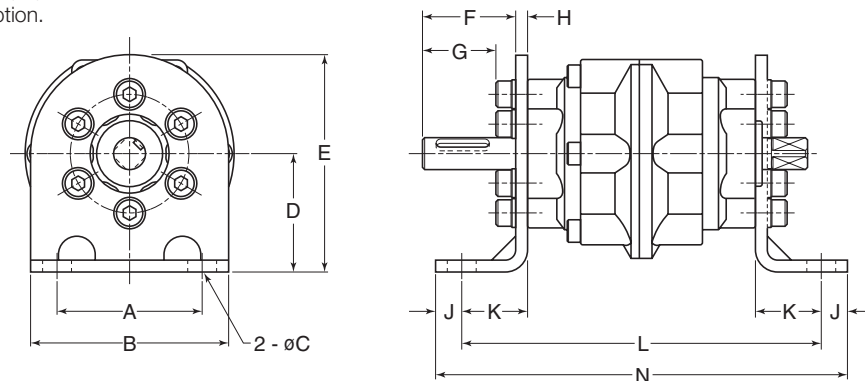
Part number	A	B	C	D	E	F
PRN50-P	64 (2.52)	80 (3.15)	7 (0.28)	39.5 (1.56)	35 (1.38)	4.5 (0.18)
PRN150-P	88 (3.46)	110 (4.33)	9 (0.35)	53.5 (2.11)	47.5 (1.87)	6 (0.24)

mm (Inches)

**Foot Mount – Sizes 50 to 800**

**Note:**

- A foot plate can be rotated in intervals of 60°.
- Two foot plates (L2) are not available with the CR, FM, FC option.



Part number	A	B	C	D	E	F	G	H	J	K	L	N
PRN50-L	55 (2.17)	75 (2.95)	11 (0.43)	45 (1.77)	82.5 (3.25)	35 (1.38)	27.5 (1.08)	4.5 (0.18)	10 (0.39)	25 (0.98)	136 (5.35)	156 (6.14)
PRN150-L	80 (3.15)	110 (4.33)	13 (0.51)	65 (2.56)	115 (4.53)	43.5 (1.71)	33.5 (1.32)	10 (0.39)	12 (0.47)	28 (1.10)	159 (6.26)	183 (7.20)
PRN300-L	100 (3.94)	140 (5.51)	15 (0.59)	80 (3.15)	135 (5.31)	53 (2.09)	40.5 (1.59)	12 (0.47)	13 (0.51)	32 (1.26)	189 (7.44)	215 (8.46)
PRN800-L	140 (5.51)	200 (7.87)	15 (0.59)	110 (4.33)	200 (7.87)	54.5 (2.15)	39.5 (1.56)	15 (0.59)	15 (0.59)	35 (1.38)	241 (9.49)	271 (10.67)

mm (Inches)



For inventory, lead time, and kit lookup, visit [www.pdnplu.com](http://www.pdnplu.com)

**Shock Absorber**

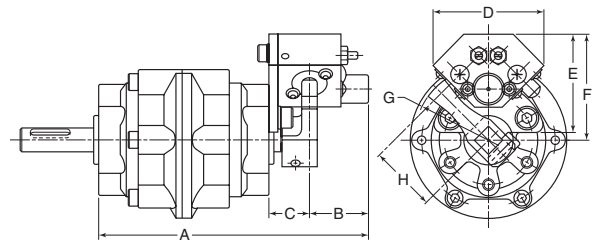
The CRN Series Shock Absorber should be used in applications involving high inertial loads. Inertial loads are a result of any or all of the following:

- High cycle speeds
- Heavy loads
- Physically / dimensionally large loads

When any of these characteristics are present, it is important that some means of deceleration, such as the CRN, is used.

**Notes:**

- It is critical not to exceed the maximum kinetic energy values of the CRN. See chart below for kinetic energy calculations.
- When ordering a CRN, the shock absorber and the shock arm must be ordered separately.
- When a CRN is specified, maintain a minimum working pressure of 0.3 MPa.



Part number	A	B	C	D	E	F	G	H
<b>CRN50</b>	136.5 (5.37)	30 (1.18)	20.5 (0.81)	56 (2.20)	50 (1.97)	54 (2.13)	R38 (1.50)	34 (1.34)
<b>CRN150</b>	159.5 (6.28)	34 (1.34)	22.5 (0.89)	80 (3.15)	62 (2.44)	71.5 (2.81)	R51 (2.01)	46 (1.81)
<b>CRN300</b>	187.5 (7.38)	37 (1.46)	25.5 (1.00)	95 (3.74)	87 (3.43)	96 (3.78)	R68 (2.68)	62 (2.44)
<b>CRN800</b>	244 (9.61)	42 (1.65)	31 (1.22)	130 (5.12)	118 (4.65)	135 (5.31)	R78 (3.07)	90 (3.54)

mm (Inches)

**Shock Absorber Only**

**CRN50**

Model	
<b>CRN50</b>	for PRN50
<b>CRN150</b>	for PRN150
<b>CRN300</b>	for PRN300
<b>CRN800</b>	for PRN800

**Shock Arm**

**CRN50**

Model	
<b>CRN50</b>	for PRN50
<b>CRN150</b>	for PRN150
<b>CRN300</b>	for PRN300
<b>CRN800</b>	for PRN800

**90**

Rotation	
<b>90</b>	90°
<b>100</b>	180°
<b>180</b>	180°
<b>270</b>	270°
<b>280</b>	280°

**45 - T**

Reference Point	
<b>40</b>	40°
<b>45</b>	45°

**Relationship Between Rotation and Reference Point**

Options	Rotation			
	90°	180°	270°	280°
<b>40°</b>	X	X	N/A	X
<b>45°</b>	X	N/A	X	N/A

**Note:** Select a shock arm based on the reference point and rotation of the PRN to be used.

Model No.	Unit	CRN50	CRN150	CRN300	CRN800
Kinetic Energy (per cycle)	J	7.8	10	20	156
	in-lb	68	85	170	1356
Maximum Angular Velocity	Degree/s	850	750	650	550
Kinetic Energy (per hour)	J/hr	3100	11300	22000	56500
	in-lb/hr	26939	98197	191180	490985
Temperature Range	°C	5 to 50	5 to 50	5 to 50	5 to 50
	°F	41 to 122	41 to 122	41 to 122	41 to 122
Deceleration Angle	Degree	11	12	14	15
Weight	g	240	420	780	1620
	lb	0.528	0.924	1.716	3.564



For inventory, lead times, and kit lookup, visit [www.pdnplu.com](http://www.pdnplu.com)

H20

**Parker Hannifin Corporation**  
Pneumatic Division  
Richland, Michigan  
[www.parker.com/pneumatics](http://www.parker.com/pneumatics)



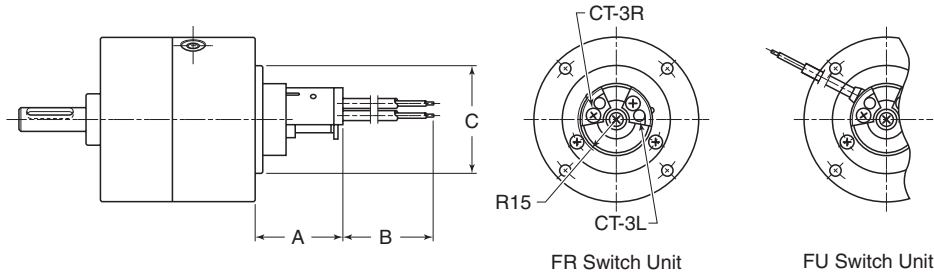
**Variable Position Solid State (FR Series) Sensor**

The FR Series variable position sensor provides the ability to adjust the sensor to sense along the full travel of the actuator. All switches and sensors must be ordered separately.

See the Electronic Sensors section for part numbers and

sensor specifications.

**Note:** Not to be used in conjunction with rear ports (S).



Model	A	B	C
PRNA1	31.9 (1.26)	1000 (39.37)	29 (1.14)
PRNA3	30.7 (1.21)	1000 (39.37)	35 (1.38)
PRNA10	34 (1.34)	1000 (39.37)	42 (1.65)
PRNA20	34 (1.34)	1000 (39.37)	42 (1.65)
PRN30	34 (1.34)	1000 (39.37)	42 (1.65)

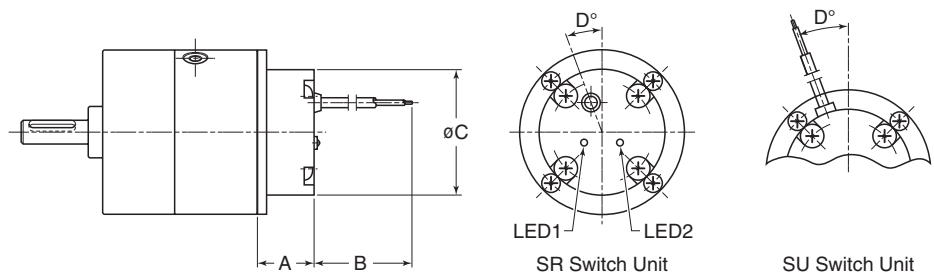
mm (Inches)

**Fixed Position Solid State (SR / SU Series) Sensor**

The SR or SU Series fixed position sensor senses the end of stroke only. All switches and sensors must be ordered separately.

See the Electronic Sensors section for part numbers and sensor specifications.

**Note:** Not to be used in conjunction with rear ports (S).



Model	A	B	C	D
PRNA1	N/A	N/A	N/A	N/A
PRNA3	18 (0.71)	1000 (39.37)	36 (1.42)	30 (1.18)
PRNA10	18.3 (0.72)	1000 (39.37)	42 (1.65)	25 (0.98)
PRNA20	18.3 (0.72)	1000 (39.37)	49 (1.93)	20 (0.79)
PRN30	21.8 (0.86)	1000 (39.37)	49 (1.93)	20 (0.79)

mm (Inches)

PV Series  
PRN(A) Series  
PTR Series  
B671/F672 Series  
HP Series  
Rotary Actuators Products



For inventory, lead time, and kit lookup, visit [www.pdnplu.com](http://www.pdnplu.com)

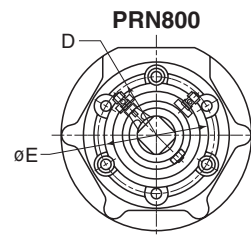
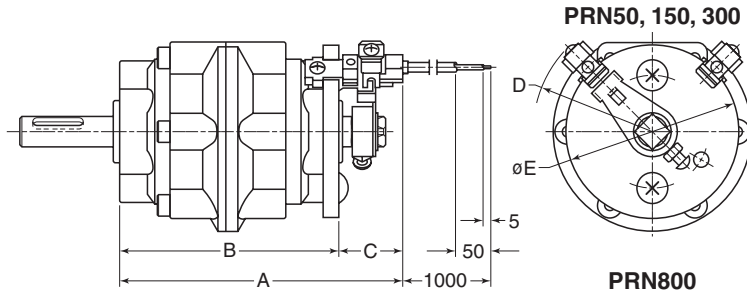
H21

**Parker Hannifin Corporation**  
Pneumatic Division  
Richland, Michigan  
[www.parker.com/pneumatics](http://www.parker.com/pneumatics)

**Variable Position Solid State (FR / FC Series) Sensor**

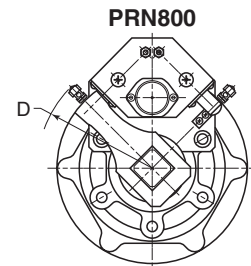
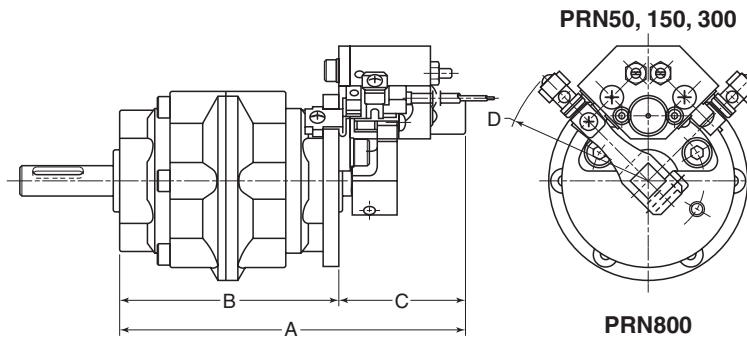
The FR and FC Series variable position sensor provides the ability to adjust the sensor to sense along the full travel of the actuator. The FR Series sensor is to be used with the standard PRN sizes 50–800, and the FC Series sensor is to be used when a CRN Series shock absorber is specified.

See the Electronic Sensors section for part numbers and sensor specifications.



Model No.	A	B	C	D	E
PRN50	115 (4.53)	87.2 (3.43)	27.5 (1.08)	R47 (1.85)	69 (2.72)
PRN150	131.7 (5.19)	104.2 (4.10)	27.5 (1.08)	R61 (2.40)	97 (3.82)
PRN300	161.2 (6.35)	126.2 (4.97)	35 (1.38)	R69 (2.72)	113 (4.45)
PRN800	215.5 (8.48)	174.2 (6.86)	41.3 (1.63)	R60 (2.36)	108 (4.25)

mm (Inches)



Model No.	A	B	C	D
PRN50	137.7 (5.42)	87.2 (3.43)	50.5 (1.99)	R58.2 (2.29)
PRN150	160.7 (6.33)	104.2 (4.10)	56.5 (2.22)	R72.2 (2.84)
PRN300	188.7 (7.43)	126.2 (4.97)	62.5 (2.46)	R88.2 (3.47)
PRN800	244 (9.61)	174.2 (6.86)	69.8 (2.75)	R118.5 (4.67)

mm (Inches)



For inventory, lead times, and kit lookup, visit [www.pdnplu.com](http://www.pdnplu.com)

**PTR Series**

**TUBING & BODY**

Aluminum is hard-coat anodized and permanently sealed for maximum wear resistance and long life.

**RACK & PINION**

Heavy duty gear design is made from through hardened chrome alloy steel for maximum strength and shock resistance. The gear chamber is prelubricated to provide millions of trouble-free cycles.

**PISTON SEALS**

Unique geometry of lipseal provides low breakaway pressure and long life. The specially formulated Nitroxile ELF compound incorporates a unique internal lubricant to provide the lowest breakaway and running friction, while maintaining the best wear resistance available. Can be operated with no added lubrication.

**SEALED BALL BEARINGS**

Reduce friction and breakaway pressure while providing substantial pinion and shaft support. This ensures a rigid and long lasting assembly, even for high cycle applications.

**STANDARD MALE KEYED SHAFT**

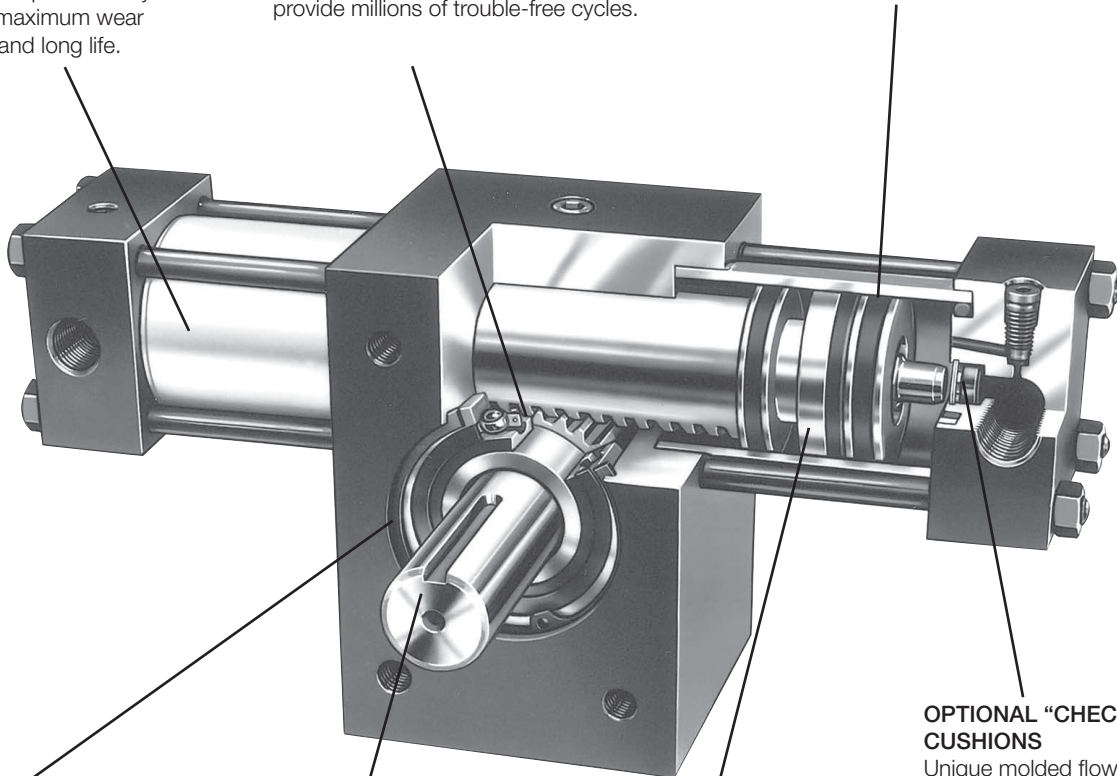
Is as large as possible to ensure superior strength; pinion and output shaft are one-piece to provide long life. A female shaft is available.

**PISTONS**

Floating Wear-Tech® aluminum pistons are supported at both ends by rugged filled PTFE wear bands which prevent cylinder scoring, galling, and binding. A magnet groove is standard on all pistons, allowing field conversion to position sensors.

**OPTIONAL "CHECK SEAL" CUSHIONS**

Unique molded flow passages combine the benefits of floating cushions with check valve action, providing effective cushioning and quick stroke reversal for higher cycle and production rates. This proven design eliminates failure-prone springs and ensures minimum wear. An adjustable needle valve and springless check valve allow exact "tailoring" of the cushion to match the application.



PV Series
PRN(A) Series
<b>PTR Series</b>
B671/F672 Series
HP Series
Rotary Actuators Products



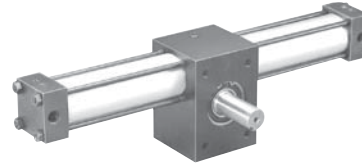
For inventory, lead time, and kit lookup, visit [www.pdnplu.com](http://www.pdnplu.com)

H23

**Parker Hannifin Corporation**  
Pneumatic Division  
Richland, Michigan  
[www.parker.com/pneumatics](http://www.parker.com/pneumatics)

## Features

- Rack and pinion rotary actuator
- 5 bore sizes from 1" to 3-1/4"
- Output torque @ 100 PSIG: 39 lb-in to 2281 lb-in
- Standard rotations: 90°, 180°, 270°, 360°
- Available as single or double rack, 3 position, air/oil, antibacklash
- Optional bumpers, cushions, stroke adjusters, shock absorbers



### Operating information

Operating pressure:	250 PSIG (17 bar)
Temperature range:	
Nitrile seals	0°F to 180°F (-18° to 82°C)
Fluorocarbon seals	0°F to 250°F (-18° to 121°C)
Filtration requirements:	40 micron, dry filtered air

### Sensors

See section L for sensors.



## Ordering information

**PTR 25 1 - 090 3 F P - A B 2 1 M V - C**

Model <sup>1</sup>	
10	1" Bore
15	1-1/2" Bore
20	2" Bore
25	2-1/2" Bore
32	3-1/4" Bore

Rotation <sup>2</sup>	
090	90°
180	180°
270	270°
360	360°

Or specify any other rotation.

Configuration	
1	Single Rack
2	Double Rack
3	Three Position Actuator
6	Air/Oil Operation
7	Antibacklash

Mounting	
A	Face/base (standard)
F	Front flange
G	Foot flange
P	Pilot ring
R	Rear flange
X	Special

Design Series	
C	Current

### Special Options

Omit	Standard
(Two-digit code assigned by factory and applies when any "X" or "9" appears in the model number or when special options or features are required.)	

Port flow controls	
Omit	None
P	Flow control both rotations
R	Flow control CW rotation <sup>3</sup>
S	Flow control CCW rotation <sup>3</sup>

Seals	
Omit	Nitrile
V	Fluorocarbon
X	Special

Standard options	
Omit	None
M	Magnetic piston ring
S	Shaft seal cover
Q	Prepped for external air/oil tank
L	Air/oil cushion & flow control adj. at location 1 (opposite standard)

Shaft	
A	Female keyed
B	Single male keyed (standard)
C	Double male keyed
D	Double male keyed, single end - metric
E	Female keyed - metric
F	Male keyed, double end - metric
R	Preload keyway
X	Special

Port location	
1	Position 1 (standard)
2	Position 2
3	Position 3
4	Position 4 <sup>8</sup>
5	Position 5 <sup>6</sup>
9	Special

Port type	
1	SAE straight thread
2	NPTF
4	BSPP (ISO 1179-1 with ISO 228-1 threads)
9	Special

### Other options

Detail in clear text:
• Proximity Sensors
• Feedback Potentiometer

### Notes:

- <sup>1</sup> Cylinder bore size. See appropriate tables for torque output.
- <sup>2</sup> For 3-position units, specify middle and total rotation separated by a "/", ie 090/180. To obtain equal rotation both sides of midstroke (theoretical 12:00), order unit with 5° longer rotation than standard with stroke adjusters.
- <sup>3</sup> Viewed from shaft end.
- <sup>4</sup> Double rack models only.
- <sup>5</sup> Reduces to 10° with cushions.
- <sup>6</sup> Not available with cushions or stroke adjusters.
- <sup>7</sup> Stroke adjusters for option configuration compatibility.
- <sup>8</sup> Not available on double rack models
- <sup>9</sup> Not available with flow controls

Cushion / Bumpers	
Omit	None
1	Cushioned CW rotation <sup>3</sup>
2	Cushioned CCW rotation <sup>3</sup>
3	Cushioned both rotations
4	Four cushions <sup>4</sup>
5	Bumper CW rotation <sup>3</sup>
6	Bumper CCW rotation <sup>3</sup>
7	Bumper both rotations
9	Special

Stroke adjusters	
Omit	None
D	0-30° CW rotation <sup>3,5</sup>
E	0-30° CCW rotation <sup>3,5</sup>
F	0-30° both rotations <sup>5</sup>
H	Shock/stroke adj. CW rotation <sup>3,7,9</sup>
K	Shock/stroke adj. CCW rotation <sup>3,7,9</sup>
L	Shock/stroke adj. both rotations <sup>7,9</sup>
X	Special



For inventory, lead times, and kit lookup, visit [www.pdnplu.com](http://www.pdnplu.com)

H24

**Parker Hannifin Corporation**  
Pneumatic Division  
Richland, Michigan  
[www.parker.com/pneumatics](http://www.parker.com/pneumatics)

**Quick reference data**

Model		Typ. actual output torque @ 100 PSI (lb-in)	Theoretical output torque* (lb-in) versus input pressure (PSI)				Displacement per degree rotation (in <sup>3</sup> /°)	Maximum angular backlash (minutes)	Tolerance (degrees)
Single rack	Double rack		50	75	100	250			
101		35	19	29	39	98	0.007	60	-0, +5
	102	70	39	59	79	197	0.014	60	-0, +5
151		100	59	88	118	294	0.021	45	-0, +4
	152	200	118	177	236	590	0.042	45	-0, +4
201		250	141	212	282	705	0.049	35	-0, +3
251		375	215	322	430	1074	0.075	35	-0, +3
	202	500	282	423	565	1410	0.099	35	-0, +3
	252	750	430	644	859	2148	0.150	35	-0, +3
321		1000	570	856	1141	2852	0.199	25	-0, +2
	322	2000	1141	1711	2281	5703	0.398	25	-0, +2

\* Allow 10% for friction loss. Allow 20% on air/oil units. Use the single rack torque values for all air/oil, three position, and anti-backlash actuators.

**Bearing load capacities and kinetic energy ratings**

Model	Bearing load capacities* (lb)		Distance between bearings	Maximum kinetic energy absorption rating for models based on configuration (lb-in)			
	Radial	Thrust		Standard or stroke adjusters	Bumper	Cushion**	Shock absorbers (per cycle / per hour)
10	100	50	1.40	0.5	0.75	5.00	15/150,000
15	250	125	2.15	1.50	2.25	15.00	35/200,000
20	500	250	2.15	3.00	4.50	35.00	140/350,000
25	750	375	2.50	5.50	8.25	55.00	140/300,000
32	1000	500	3.75	12.00	18.00	155.00	N/A

\* Bearing capacities only. Check Kinetic Energy ratings to determine if actuator will stop load.

\*\* Assuming positive back pressure provided by meter-out flow control.

PV Series

PRN(A) Series

PTR Series

B671/F672 Series

HP Series


Rotary Actuators Products



For inventory, lead time, and kit lookup, visit [www.pdnplu.com](http://www.pdnplu.com)

H25

**Parker Hannifin Corporation**  
 Pneumatic Division  
 Richland, Michigan  
[www.parker.com/pneumatics](http://www.parker.com/pneumatics)

PV Series  
 PRN(A) Series  
 PTR Series  
 B671/F672 Series  
 HP Series  
 Rotary Actuators Products  


### Kinetic Energy Calculations

In many cases, the size and life of a rotary actuator is determined not by its torque output, but rather by its energy dissipation capability. This is based on the assumption that if the actuator is capable of stopping the load, it is certainly capable of starting the load.

Both torque output and kinetic energy absorption must be considered if the actuator physically stops the load.

To calculate Kinetic Energy, the following variables are required:

1. Rotational Mass Moment of Inertia ( $J_m$ ) - See next page.
2. Total Rotation (Degrees)
3. Rotation Time (Seconds)

### KINETIC ENERGY BASIC FORMULA

$$KE = 1/2 J_m \omega^2$$

$$\omega = 0.035 \times \frac{\text{Angle Traveled (deg.)}}{\text{Rotation Time (sec.)}}$$

where

KE = Kinetic Energy (in-lb)

$J_m$  = Rotational Mass Moment of Inertia (in-lb-sec<sup>2</sup>)

See next page for formulas.

$\omega$  = Peak Velocity (rad/sec)

(Assuming twice average velocity)

### Unit Weights (lb)

Model	Rotation			
	90°	180°	270°	360°
PTR101	2-1/4	2-1/2	2-3/4	3
PTR102	3-1/2	3-7/8	4-1/4	4-5/8
PTR151	8-1/4	8-3/4	9-1/4	9-3/4
PTR152	11-3/8	12-3/8	13-3/8	14-3/8
PTR201	13-5/8	14-5/8	15-5/8	16-3/4
PTR202	19-3/4	21-7/8	24	26-1/8
PTR251	21-1/8	22-3/4	24-3/8	26
PTR252	30-3/4	34	37-1/4	40-1/2
PTR321	44-1/4	46-5/8	49	51-3/8
PTR322	61-7/8	66-5/8	71-3/8	76-1/8

### Seal kit ordering information

- Standard units are equipped with Nitrile seals.
- Optional seal compounds are available.
- Seal kit part numbers as shown:

<b>PSK</b> Parker seal kit	—	<b>PTR322</b> Base model	<b>V</b>
			<b>Omit</b> Standard
			<b>V</b> Fluorocarbon
			<b>Q</b> Quad ring piston seals
			<b>W</b> Carboxilated nitrile piston seals



For inventory, lead times, and kit lookup, visit [www.pdnplu.com](http://www.pdnplu.com)

H26

**Parker Hannifin Corporation**  
 Pneumatic Division  
 Richland, Michigan  
[www.parker.com/pneumatics](http://www.parker.com/pneumatics)

**Kinetic Energy Basic Formula**

$$KE = 1/2 Jm\omega^2$$

$$\omega = 0.035 \times \frac{\text{Angle Traveled (Deg.)}}{\text{Rotation Time (Sec.)}}$$

where:

KE = Kinetic Energy (in-lb)

Jm = Rotational mass moment of inertia (in-lb-sec<sup>2</sup>)  
 (Dependent on physical size of object and weight)

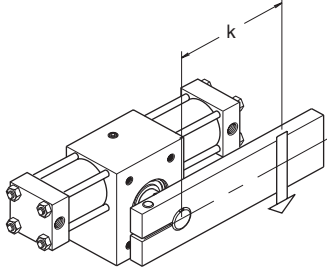
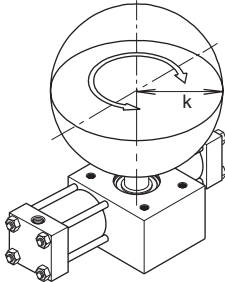
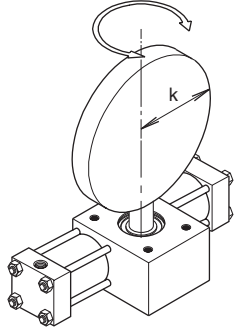
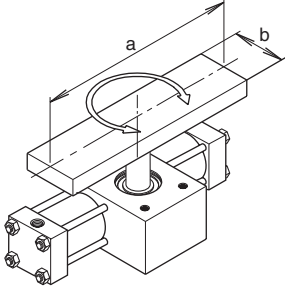
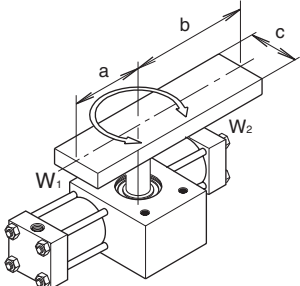
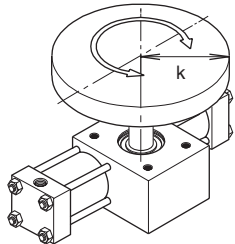
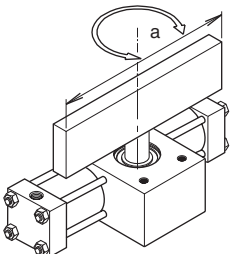
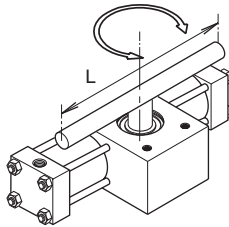
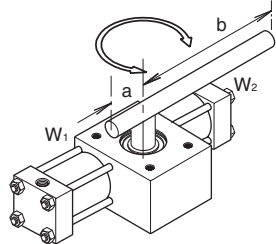
$\omega$  = Peak Velocity (rad/sec) (Assuming twice average velocity)

W = Weight of load (lb)

g = Gravitational constant = 386.4 in/sec<sup>2</sup>

k = Radius of gyration (in)

**Moments of Inertia**

<p><b>POINT LOAD</b></p>  $Jm = \frac{W}{g} \times k^2$	<p><b>SOLID SPHERE -</b>                      Mounted on center</p>  $Jm = \frac{2}{5} \times \frac{W}{g} \times k^2$	<p><b>THIN DISK -</b>                      End mounted on center</p>  $Jm = \frac{W}{g} \times \frac{k^2}{4}$
<p><b>THIN RECTANGULAR PLATE -</b>                      Mounted on center</p>  $Jm = \frac{W}{g} \times \frac{a^2 + b^2}{12}$	<p><b>THIN RECTANGULAR PLATE -</b>                      Mounted off center</p>  $Jm = \frac{W_1}{g} \times \frac{4a^2 + c^2}{12} + \frac{W_2}{g} \times \frac{4b^2 + c^2}{12}$	<p><b>THIN DISK -</b>                      Mounted on center</p>  $Jm = \frac{W}{g} \times \frac{k^2}{2}$
<p><b>THIN RECTANGULAR PLATE -</b>                      End mounted on center</p>  $Jm = \frac{W}{g} \times \frac{a^2}{12}$	<p><b>SLENDER ROD -</b>                      Mounted on center</p>  $Jm = \frac{W}{g} \times \frac{L^2}{12}$	<p><b>SLENDER ROD -</b>                      Mounted off center</p>  $Jm = \frac{W_1}{g} \times \frac{a^2}{3} + \frac{W_2}{g} \times \frac{b^2}{3}$

PV Series

PRN(A) Series

PTR Series

B671/F672 Series

HP Series

Rotary Actuators Products



For inventory, lead time, and kit lookup, visit [www.pdnplu.com](http://www.pdnplu.com)

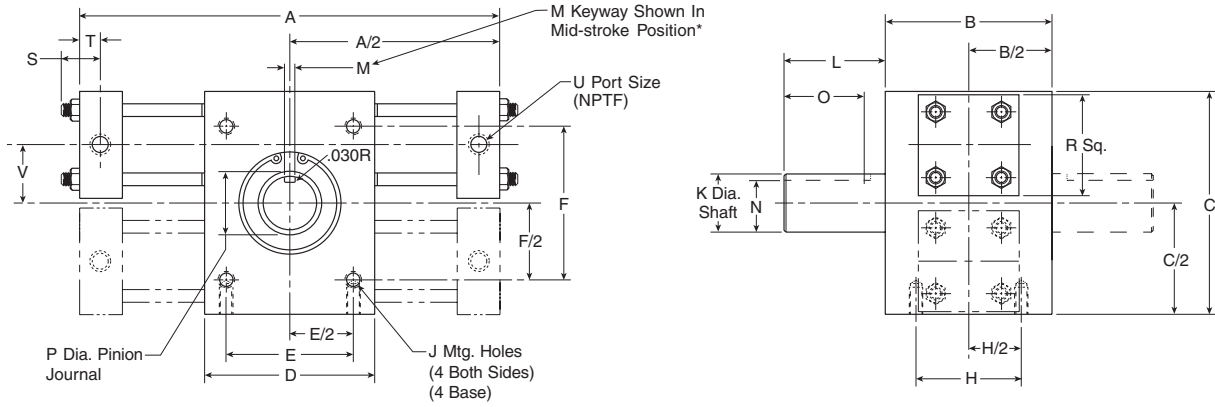
H27

**Parker Hannifin Corporation**  
 Pneumatic Division  
 Richland, Michigan  
[www.parker.com/pneumatics](http://www.parker.com/pneumatics)

**Dimensional Data**

**Standard Face Base Mount (A) and Male Keyed Shaft (B)**

Double Male Keyed Shaft (C) shown in phantom



Model number	Rotation (Degrees)	A	B	C	D	E	F	H	J	K	L	M	N
10	90°	6-11/16											
	180°	8-1/4	2	3	2	1.500	2.000	1.500	1/4-20 x 3/8 DP	0.500 0.499	7/8	0.125 0.127	0.430 0.425
	360°	11-7/16											
15	90°	9-1/8											
	180°	11-3/16	3	4-1/4	3	2.000	3.000	2.000	5/16-18 x 1/2 DP	0.875 0.874	1-7/8	0.188 0.190	0.771 0.761
	360°	15-3/8											
20	90°	11-3/16											
	180°	14-1/16	3	5	4	2.500	3.500	2.000	3/8-16 x 1/2 DP	1.125 1.124	1-7/8	0.250 0.252	0.986
	360°	19-11/16											
25	90°	12-9/16											
	180°	15-1/2	3-1/2	6	4	2.500	4.500	2.000	1/2-13 x 3/4 DP	1.375 1.374	2-1/4	0.313 0.315	1.201 1.191
	360°	20-5/8											
32	90°	16-5/8											
	180°	21-1/8	5	8	5	3.000	5.000	2.500	3/4-10 x 1 DP	1.750 1.749	3-1/2	0.375 0.377	1.542 1.532
	360°	29-3/8											

Model number	O	P	R	S	T	U	V
10	5/8	0.59	1-1/2	1/4	0.31	1/8	3/4
15	1-1/2	0.98	2	5/16	0.41	1/4	1-1/16
20	1-1/2	1.18	2-1/2	3/8	0.41	1/4	1-1/4
25	1-3/4	1.38	3	3/8	0.41	1/4	1-1/2
32	3	1.77	3-3/4	7/16	0.56	3/8	1-15/16

\* To obtain equal rotation both sides of midstroke (theoretical 12:00), order 5° longer rotation than standard with stroke adjusters.



For inventory, lead times, and kit lookup, visit [www.pdnplu.com](http://www.pdnplu.com)

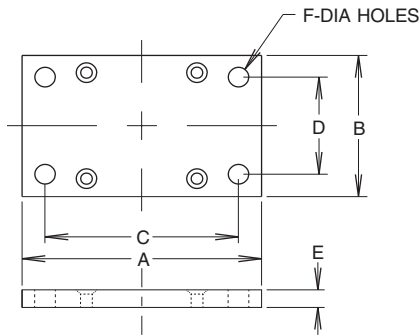
H28

**Parker Hannifin Corporation**  
Pneumatic Division  
Richland, Michigan  
[www.parker.com/pneumatics](http://www.parker.com/pneumatics)



**Mounting Options (F, G, P, R)**

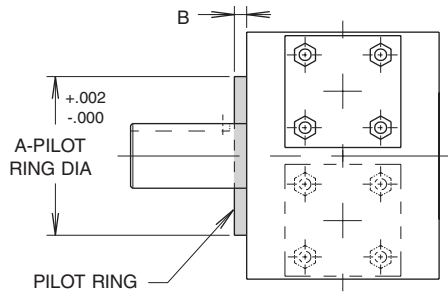
**Foot Flange (G)**



**Note:** Actuators are shipped with mounting flange installed unless otherwise noted.

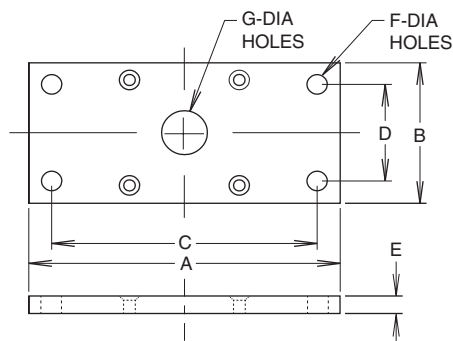
Model	A	B	C	D	E	F
10	3.25	2.00	2.625	1.375	0.250	0.281
15	4.50	3.00	3.875	2.125	0.438	0.406
20	4.50	4.00	3.875	3.375	0.438	0.406
25	5.50	4.00	4.500	3.000	0.438	0.531
32	8.00	5.00	6.500	3.500	0.750	0.781

**Pilot Ring (P)**



Model	A	B
10	1.124	0.125
15	2.000	0.25
20	2.167	0.25
25	2.679	0.25
32	3.348	0.25

**Front Flange (F)**  
**Rear Flange (R)**



Model	A	B	C	D	E	F	G
10	4.25	2.00	3.625	1.375	0.250	0.281	0.625
15	5.75	3.00	5.125	2.125	0.438	0.406	1.000
20	6.50	4.00	5.875	3.375	0.438	0.406	1.250
25	8.25	4.00	7.250	3.000	0.438	0.531	1.625
32	12.00	5.00	10.000	3.000	0.750	0.781	2.000

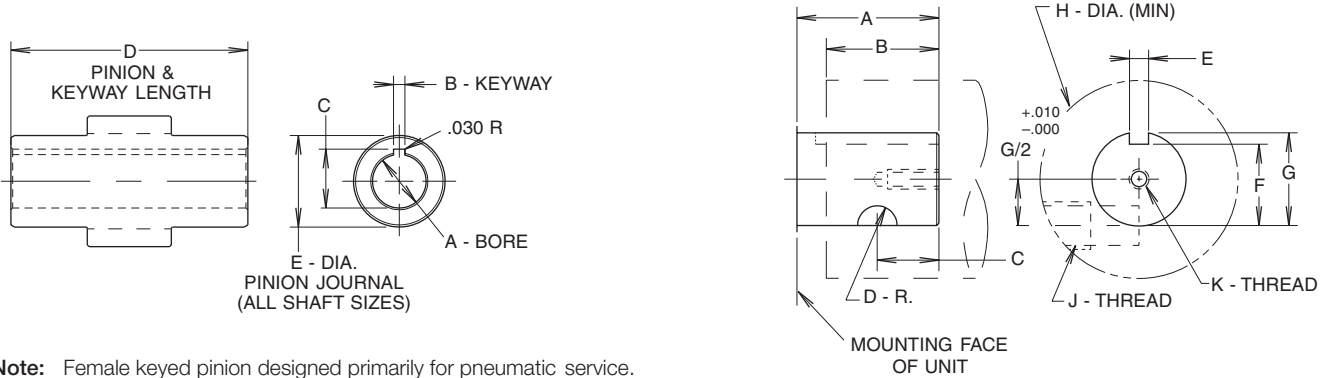
PV Series  
 PRN(A) Series  
 PTR Series  
 B671/F672 Series  
 HP Series  
 Rotary Actuators Products  
**H**



For inventory, lead time, and kit lookup, visit [www.pdnplu.com](http://www.pdnplu.com)

**Shaft Options (C, A, R)**

Units are equipped standard with single male keyed shaft (B). Double male keyed (C) also available as shown on page H24. Also available in female keyed and preload keyway options.



**Note:** Female keyed pinion designed primarily for pneumatic service. Review shaft stresses before applying on hydraulic service.

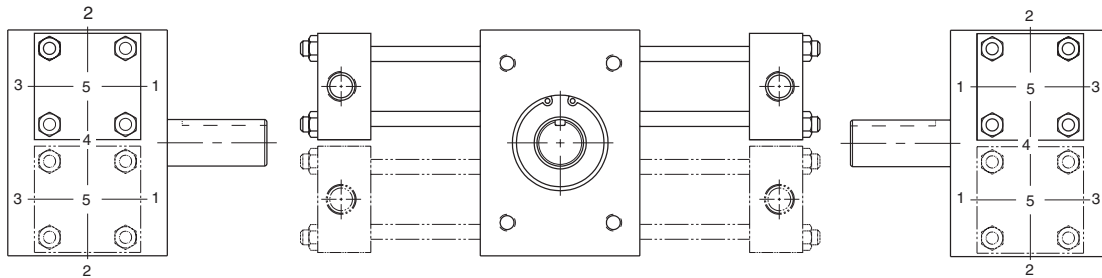
**Female Keyed (A)**

Model	A	B	C	D	E
10	0.375	0.093	0.417	1-13/32	0.59
	0.377	0.095	0.422		
15	0.500	0.125	0.560	2-11/16	0.98
	0.502	0.127	0.565		
20	0.750	0.187	0.837	2-23/32	1.18
	0.752	0.189	0.847		
25	1.000	0.250	1.083	3-1/8	1.38
	1.002	0.252	1.093		
32	1.250	0.250	1.367	4-9/16	1.77
	1.252	0.252	1.377		

**Preload Key (R)**

Model	A	B	C	D	E	F	G	H	J	K
10	7/8	5/8	0.375	0.156	0.125	0.430	0.500	1-1/2	3/8-24	10-32 x 3/8 DP
					0.127	0.425	0.499			
15	1-7/8	1-1/2	0.812	0.219	0.188	0.771	0.875	2	1/2-20	5/16-24 x 1/2 DP
					0.190	0.761	0.874			
20	1-7/8	1-1/2	0.812	0.250	0.250	0.986	1.125	3	5/8-11	3/8-24 x 9/16 DP
					0.252	0.976	1.124			
25	2-1/4	1-3/4	1.000	0.250	0.313	1.201	1.375	3-1/2	3/4-10	3/8-24 x 9/16 DP
					0.315	1.191	1.374			
32	3-1/2	3	1.500	0.437	0.375	1.542	1.750	4	1-8	1/2-20 x 3/4 DP
					0.377	1.532	1.749			

**Port Size and Location (1, 2, 3, 4)**



**Notes:**

- Port position 1 is standard.
- Port positions 2, 3 and 4 are standard options available at no additional cost.
- Port position 4 is for single rack only.
- Port position 5 is not available with cushions or stroke adjusters.

Model	Optional SAE straight thread (1)	Standard NPT (2)
10	7/16 - 20 (SAE 4)	1/8
15	7/16 - 20 (SAE 4)	1/4
20	9/16 - 18 (SAE 6)	1/4
25	9/16 - 18 (SAE 6)	1/4
32	3/4 - 16 (SAE 8)	3/8



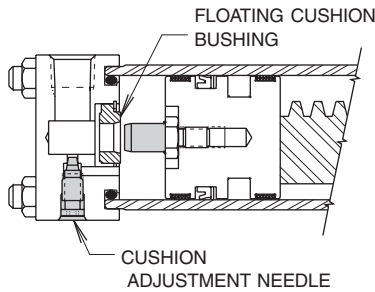
For inventory, lead times, and kit lookup, visit [www.pdnplu.com](http://www.pdnplu.com)

H30

**Parker Hannifin Corporation**  
 Pneumatic Division  
 Richland, Michigan  
[www.parker.com/pneumatics](http://www.parker.com/pneumatics)

**Cushions (1, 2, 3, 4)**

The standard cushions operate over the last 30° of rotation in either or both directions. A floating bushing ensures no binding of the cushion spear. For severe operating conditions, four cushions can be fitted on double rack units. All cushions are fully adjustable. On double rack units, cushions will be located on the upper cylinder.



**Standard Cushion Needle Locations**

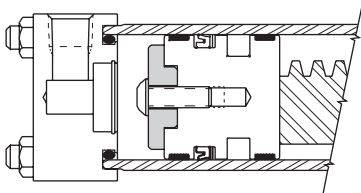
(Reference diagram on previous page)

Port position	Cushion position
1	2
2	3
3	2
4*	3
5	N/A

\*Single Rack only

**Bumpers (5, 6, 7)**

Built-in polyurethane bumper pads absorb shock and noise, thus permitting faster cycle times and increased production rates. Bumpers are available for pneumatic service only.



**Bumper Thickness**

Add the bumper thickness to overall unit length "A" for each bumper specified.

Model	Bumper only	Bumper with stroke adjuster
10	0.13	0.44
15	0.19	0.63
20	0.25	0.75
25	0.25	0.75
32	0.25	1.00

**Notes:**

1. Available with or without stroke adjusters
2. Not available with cushions

PV Series

PRN(A) Series

PTR Series

B671/F672 Series

HP Series

Rotary Actuators Products

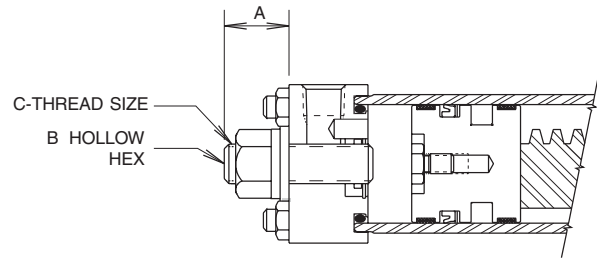


**Stroke Adjusters (D, E, F) 30°**

Stroke adjusters will reduce angle of rotation by 30° in either or both directions. Typical applications are for initial set-up purposes where exact rotation cannot be pre-determined or when rotation requirements may change between various operations. Not available with port position 5.

**Notes:**

- Standard cushions operate over the last 30° of rotation. Stroke adjusters will decrease the effective cushion length by the same amount. For example, reducing the rotation by 5° yields a 25° cushion length. For effective cushions it is recommended that stroke adjustment not exceed 10° when used in conjunction with cushions.
- Maximum unit rotation is equal to rotation specified in model code. Adjusters allow rotational positioning equal to or less than the maximum rotation.
- 30° Stroke Adjusters are available with or without cushions. Double rack units will have cushions on upper rack and adjusters on lower rack. Single rack units with cushions (and double rack units with four cushions) and stroke adjusters will require additional "A" length.
- Antibacklash can be achieved on double rack units with stroke adjusters as long as extra rotation is ordered.
- When ordering cushions and stroke adjusters, the maximum adjustment is 10° per side.



Model	(1) Turn Adj.	30° Adjustment w/o cushioned end cap, A (max)	10° Adjustment w/ cushioned end cap, A (max)	B	C
10	4.0°	0.63	0.38	1/8	1/4-28 UNF
15	4.6°	0.88	1.13	1/4	1/2-20 UNF
20	3.2°	1.13	1.13	1/4	1/2-20 UNF
25	3.2°	1.13	1.18	1/4	1/2-20 UNF
32	2.4°	1.50	2.13	3/8	3/4-16 UNF

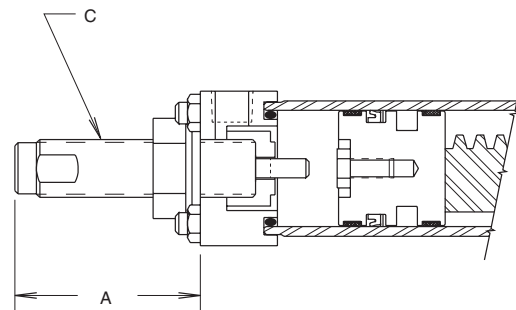
**Shock / Stroke Adjusters (H, K, L)**

Hydraulic shock absorbers reduce noise and allow increased operating speeds and loads while also providing adjustability for end of rotation position. Shocks are fixed orifice self-compensating type and will provide constant deceleration despite changing energy conditions.

**Notes:**

- Not available on Model 32 or with port position 5.
- When specified with **DOUBLE RACK UNITS**: As a result of high energy levels and driving forces obtained with double rack units, all double rack actuators will contain four shock absorbers.
- This option is not available in combination with the following options:
  - Air/Oil (6)
  - External Air/Oil (Q)
  - Bumpers (5, 6, 7)
  - Cushions (1, 2, 3, 4)
  - Port Flow Controls (P, R, S)
  - End Cap Mounted Proximity Sensors

(Tie rod mounted reed and Hall effect sensors can be specified.)



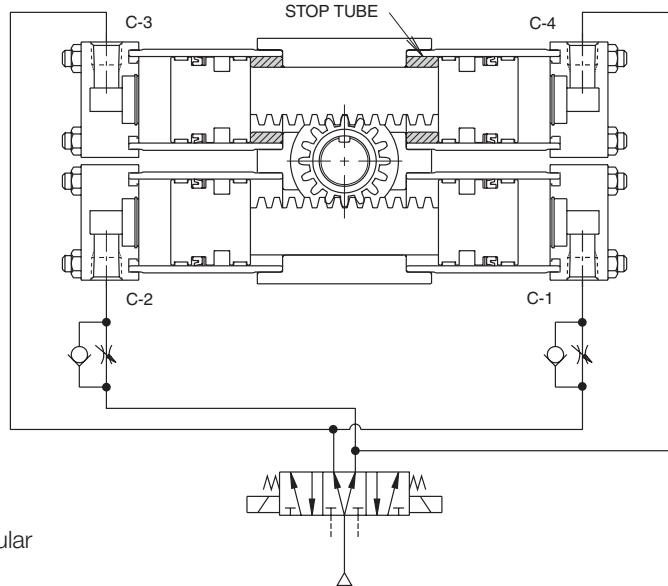
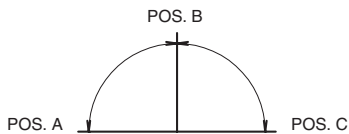
Model	(1) Turn adjustment	A (max)	Max. adjustment	C thread size
10	6°	2.20	110°	9/16 - 18 UNF
15	5°	2.40	80°	3/4 - 16 UNF
20	5°	3.66	130°	1 - 12 UNF
25	5°	3.66	130°	1 - 12 UNF



For inventory, lead times, and kit lookup, visit [www.pdnplu.com](http://www.pdnplu.com)

**Three Position Actuator (3)**

In addition to the standard two position actuators, three position units are also available. All standard options are also available.



**Operation:**

A standard double rack unit is fitted with stop tubes on the upper rack. Pressurizing port C-2 (with ports C-1, C-3 exhausted) causes counter-clockwise pinion rotation to angular position A. Alternately applying pressure to C-1 (with C-2, and C-4 exhausted) will cause clockwise rotation to angular position C. Both positions A and C are at end of stroke, thus typical end cap options such as cushions, bumpers, and stroke adjusters will operate at these positions only.

Position B is obtained by pressurizing all ports. Pressure applied to the upper floating pistons centers the rack between the stop tubes, rotating the pinion to position B. The lower rack is free floating as the forces are equal on both ends.

**Dimensional Data:**

Three position actuator dimensions are identical to the standard double rack units. If stroke adjusters are specified they will be fitted to the upper rack, flow controls and cushions will be on the lower rack. Rotational tolerances are given in the chart at the right.

**Output Torque:**

Output torque of the multiple position actuator is equivalent to the torque output of the same size single rack unit. The chart to the right gives selected torque values for specified pressures.

**Ordering Information:**

Three position actuators can be ordered by inserting a 3 into the “configuration” space in the model code. The desired middle and total rotation should be stated in the model code separated by a “/”. The beginning position, 0°, need not be specified.

For example: **PTR153-045/180F-AB21-C** is a standard pneumatic actuator, three position, with an output torque of 118 lb-in at 100 psi. Position A is 0°, position B is 45°, and position C is 180°. Both positions A and C are adjustable by 30°, as the stroke adjuster option “F” was ordered.

**Rotational Tolerances**

Model	Total rotation, degrees	Between positions, degrees <sup>1</sup>	Backlash, minutes <sup>2</sup>
103	-0, +5	±1	50
153	-0, +4	±1/2	40
203	-0, +3	±1/2	30
253	-0, +2	±1/2	30
323	-0, +2	±1/4	15

1. Measured from centers of backlash.
2. Zero backlash can be achieved at positions A and C by using optional stroke adjusters.

**Theoretical Output Torque (lb-in) at Specified Pressure**

Model	50 psi	100 psi	250 psi
103	19	39	98
153	59	118	294
203	141	282	705
253	215	430	1074
323	570	1141	2852

**Note:** When magnetic piston ring option “M” is ordered, all pistons will be so equipped.

PV Series  
PRN(A) Series  
PTR Series  
B671/F672 Series  
HP Series  
Rotary Actuators Products



For inventory, lead time, and kit lookup, visit [www.pdnplu.com](http://www.pdnplu.com)

**Antibacklash Actuator (7)**

An antibacklash actuator is used to obtain precision positioning at the end of rotation. The backlash normally associated with rack and pinion actuators is eliminated by this unique configuration.

**Operation:**

A double rack unit is modified for actuation on one end only. Alternately pressurizing C-1 or C-2 causes clockwise and counter-clockwise rotation, respectively. Backlash in the rack & pinion is eliminated as the pinion is tightly “trapped” between both racks at the end of stroke, preventing any further motion.

**Dimensional Data:**

Antibacklash actuators are similar in size and configuration to standard double rack units with one set of shorter cylinders. The table to the right shows dimensions for this shorter side. If cushions, stroke adjusters or port flow controls are ordered, they will be fitted to the powered rack side.

**Output Torque:**

Output torque of the antibacklash actuator is equivalent to the torque output of the same size single rack unit. The chart to the right gives selected torque valves for specified pressures.

**Ordering Information:**

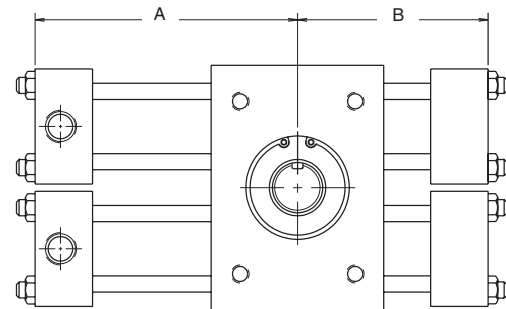
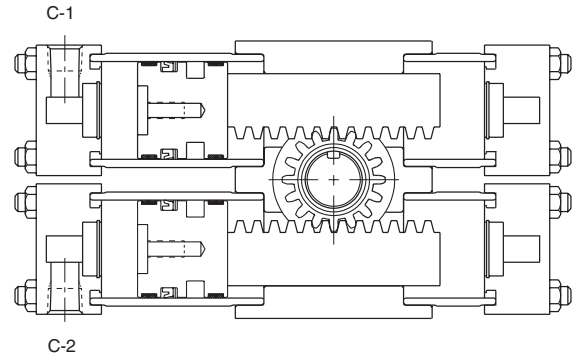
**Theoretical Output Torque, lb-in, at Specified Pressure**

Model	50 psi	100 psi	250 psi
107	19	39	98
157	59	118	294
207	141	282	705
257	215	430	1074
327	570	1141	2852

Antibacklash actuators can be ordered by inserting a “7” into the “configuration” space in the model code. For example: **PTR157-180F-AR21-C** is a pneumatic antibacklash actuator with a theoretical output torque of 118 lb-in at 100 psi.

The optional stroke adjusters make the rotation variable between 120° and 180°. The preload key option on the shaft is also specified to eliminate any backlash in the key and coupling interface.

**Note:** Antibacklash can also be obtained on double rack actuators by implementing stroke adjusters at end of stroke. This will enable you to maintain double rack output torque.



**Dimensions**

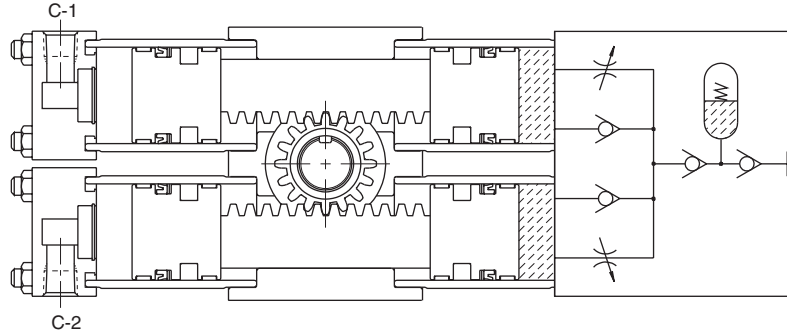
Model	Rotation	A	B
107	90°	3-3/4	2-3/4
	180°	4-1/8	3-3/4
	360°	5-3/4	5
157	90°	4-9/16	3-5/16
	180°	5-5/8	4-9/16
	360°	7-11/16	6-5/8
207	90°	5-5/8	4-1/8
	180°	7-1/16	5-5/8
	360°	9-7/8	8-1/2
257	90°	6-5/16	4-3/8
	180°	7-3/4	6-5/16
	360°	10-5/16	8-13/16
327	90°	8-5/16	5-13/16
	180°	10-9/16	8-5/16
	360°	14-11/16	12-7/16



For inventory, lead times, and kit lookup, visit [www.pdnplu.com](http://www.pdnplu.com)

**Self-Contained Tandem Air / Oil Operation (6)**

The Air-Oil Tandem actuator allows precise speed and motion control using standard pneumatic controls. This is possible through the use of a completely sealed oil system which effectively meters and controls actuator movement with no slipping, jerking, or bouncing.



**Operation:**

A standard double rack unit is equipped with a built in hydraulic reservoir and flow controls. Air pressure is alternately applied to ports C-2 and C-1 to cause rotation in either direction. As oil is displaced from the opposite end of the drive rack it is metered precisely by the needle valve. A check valve allows free flow in the opposite direction so that independent speeds for rotation can be set.

The reservoir is directly attached to the actuator, eliminating plumbing and leakage paths. It is spring loaded to compensate for oil volume changes due to temperature variations and has built in fill port.

**Dimensional Data:**

Air / Oil Actuators are identical in size and configuration to standard double rack units, with the addition of the integral reservoir as shown.

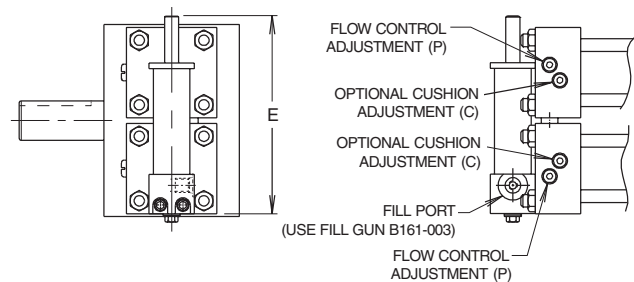
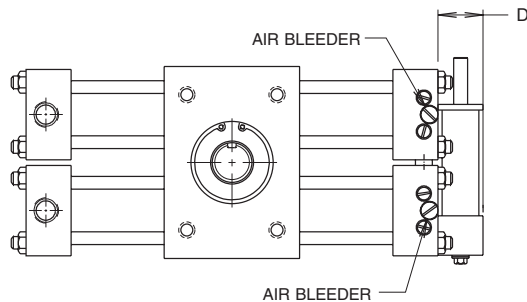
**Output Torque:**

Theoretical output torques are shown in the table below. For design and sizing purposes an actuator should be selected with 20%-50% reserve capacity.

For maximum speed of the Air/Oil actuators please consult the factory or local representative.

**Ordering Information:**

Air / Oil Tandem actuators can be ordered by placing a “6” into the “configuration” space in the model code. All Air / Oil Tandem actuators include as standard port flow controls and Quad-ring piston seals (oil side only), thus it is not necessary to include a “P” and/or “Q” in the model code. Other options, such as cushions, stroke adjusters and magnetic piston ring are also available. For example: **PTR206-180F-AB21-C** is a standard Air/Oil actuator, with a theoretical output torque of 282 lb-in at 100 psi. Rotation of the unit is 180°, with optional cushions and stroke adjusters.



**Dimensions**

Model	D	E
106	1.00	3.63
156	1.00	4.38
206	1.25	4.91
256	1.25	4.91
326	1.25	6.29

**Note:** When magnetic piston ring option “M” is ordered, only the pneumatic pistons will be so equipped.

**Theoretical Output Torque, lb-in, at Specified Pressure**

Model	50 psi	100 psi	250 psi
106	19	39	98
156	59	118	294
206	141	282	705
256	215	430	1074
326	570	1141	2852

PV Series

PRN(A) Series

**PTR Series**

B671/F672 Series

HP Series

Rotary Actuators Products



For inventory, lead time, and kit lookup, visit [www.pdnplu.com](http://www.pdnplu.com)

H35

**Parker Hannifin Corporation**  
Pneumatic Division  
Richland, Michigan  
[www.parker.com/pneumatics](http://www.parker.com/pneumatics)

**Options**

**Rotary Actuators  
PTR Series**

**External Air / Oil Operation (Q)**

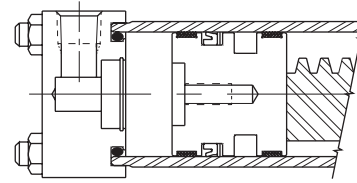
The External Air/Oil actuator allows for connection to a separate air over oil control system. It can also be used for low pressure (less than 150 psi) non-shock hydraulic systems.

**Operation:**

A standard pneumatic rotary actuator is equipped with special piston seals for all pistons to ensure low breakaway pressure and no leakage. This allows smooth, jerk-free operation, even at very low pressures.

**Output Torque:**

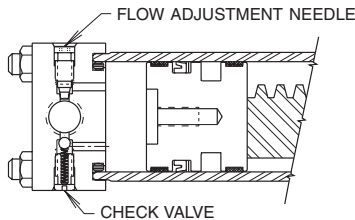
Theoretical output torques are identical to the ones given at the beginning of the PTR section. For design and sizing purposes, an actuator should be selected with 20% - 50% reserve capacity.



**NOTE:** When cushions are specified, the actuator will be equipped with bronze cushion bushings in place of the standard nitrile cushion bushings.

**Port Flow Controls (P, R, S)**

Built in meter-out flow controls provide precise adjustment of actuator speed and eliminate the cost and space of externally plumbed components. A separate ball check is used to provide free flow in the opposite direction. Flow controls may be ordered in conjunction with cushions, bumpers, or stroke adjusters.



**Standard Adjustment Needle Locations**

Port Position	Needle Position
1	2
2	3
3	2
4*	3

\* Single rack only

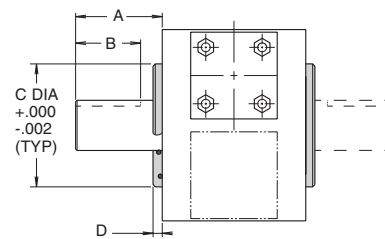
**Note:** When both cushions and port flow controls are specified they will be stamped "C" and "P" respectively.

**Shaft Seal Covers (S)**

Shaft seal covers are designed to prolong bearing life by isolating them from external contamination and pressure. They are designed for use with standard male shafts only (not hollow shafts).

**Specifications**

- Max. Pressure Differential: 500 psi
- Material: Anodized Aluminum
- Shaft Seal: Double Lip Wiper
- Body Seal: O-Ring



Model	A	B	C	D
10	7/8	1/2	1.875	0.25
15	1-7/8	1-5/16	3.000	0.38
20	1-7/8	1-5/16	3.250	0.38
25	2-1/4	1-5/8	3.625	0.38
32	3-1/2	2-7/8	4.480	0.38

**Fluorocarbon Seals (V)**

Fluorocarbon seals are recommended for high temperature applications up to 250°F. Standard abrasion resistant nitrile seals should be used for general purpose applications with temperatures of 0 to 180°F.

Option	Temperature range (°F)
Shock Absorbers	32 - 150
Bumpers	0 - 200
Piston Magnets	0 - 165
Proximity Sensors	-4 - 150
Reed/Hall Effect Sensors	14 - 140



For inventory, lead times, and kit lookup, visit [www.pdnplu.com](http://www.pdnplu.com)

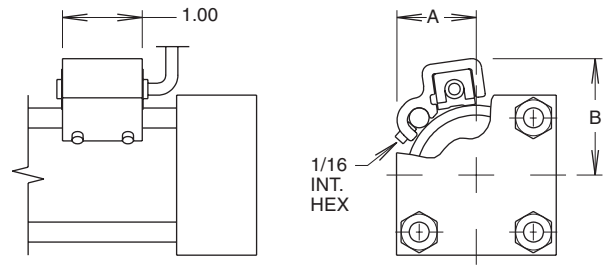
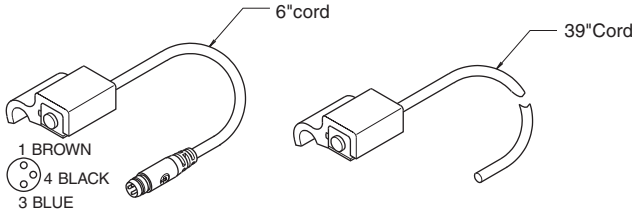
H36

**Parker Hannifin Corporation**  
Pneumatic Division  
Richland, Michigan  
[www.parker.com/pneumatics](http://www.parker.com/pneumatics)



**Magnetic Piston (M)**

This option prepares the actuator for use with reed and Hall effect sensors. The “M” option should be provided to provide a magnet on the cylinder piston. Order sensors separately from the Electronic Sensors section.



Model	A	B
10	0.84	1.22
15	0.99	1.46
20	1.27	1.68
25	1.45	1.89
32	1.71	2.20

**Proximity Sensors**

**(Namco Cylinders or Balluff Cylinder Indicator Sensor)**

The inductive type proximity sensor provides end of rotation indication. The non-contact probe senses the presence of the ferrous cushion spear and has no springs, plungers, cams or dynamic seals that can wear out or go out of adjustment. The sensor is solid state and meets NEMA 1, 12 & 13 specifications. For ease of wiring the connector housing is rotatable through 360°. To rotate, lift the cover latch, position and release.

The sensor make/break activation point may occur at 0.125" to ±0.125" from the end of stroke. Depending on the actuator size, this distance may cause activation at 2° to 15° from end of stroke.

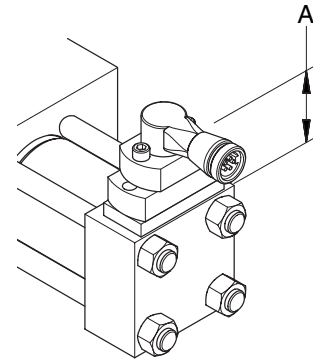
The standard proximity sensor controls 50-230 VAC/DC loads from 5 to 500 mA. The low 1.7 mA off-state leakage current can allow use for direct PLC input. The standard short circuit protection (SCP) protects the sensor from a short in the load or line upon sensing such a condition (5 amp or greater current) by assuming a non-conductive mode. The fault condition must be corrected and the power removed to reset the sensor preventing automatic restarts.

The low voltage DC sensor is also available for use with 10-30 VDC. The sensor is in a non-rotatable housing, but does incorporate the short circuit protection.

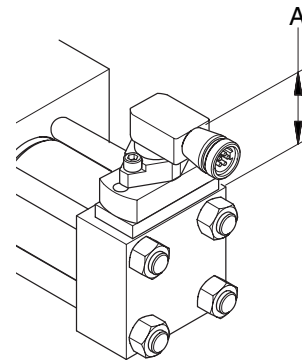
Both sensors are equipped with two LEDs, “Ready” and “Target”. The “Ready” LED is lit when power is applied and the cushion spear is not present. The “Target” LED will light and the “Ready” LED will go out when the sensor is closed, indicating the presence of the cushion spear. Both LEDs flashing indicates a short circuit condition.

**NOTES:**

1. Available with or without cushions.
2. Not available with stroke adjusters.
3. Pressure rating: 3000 psi
4. Operating temperature: -4°F to 158°F
5. Specify sensor type, orientation and voltage when ordering.
6. The low voltage DC sensor is available in non-rotatable style only; consult factory for further information.



EPS-6



EPS-7

Model	A
15	2.17
20	2.75
25	2.48
32	2.25

Order proximity sensors separately. See Electronic Sensors section for specifications and ordering information.



For inventory, lead time, and kit lookup, visit [www.pdnplu.com](http://www.pdnplu.com)

Features

B671 / F672 Series

PV Series
PRN(A) Series
PTR Series
B671/F672 Series
HP Series
Rotary Actuators Products
<b>H</b>

**BEARINGS**

High quality bronze bearings reduce friction and Break-away pressure while providing substantial pinion support.

**KEYWAY**

At 12:00 position of mid-stroke of actuator.

**PISTON SEALS**

Low friction lipseals are fully dynamic and self-compensating for no-leak service and long life at all operating pressures.

**END CAPS**

Precision machined from cold rolled steel to exacting NFPA specifications, then black oxide coated for greater reliability and durability.

**PORTS**

Full area ports provide unrestricted flow for maximum operating speeds.

**OPTIONAL CUSHIONS**

Provide maximum performance and reduced shock in all applications. The floating polyurethane cushion seal provides maximum sealing effectiveness as the spear enters the cushion, yet allows fast "out-stroke" action by functioning as a springless check valve. Full adjustment of the cushion is obtained by the flush mounted adjustment needle.

**RACK & PINION**

Chromium alloy steel with flame hardening ensures maximum shock resistance and strength of the rack & pinion.

**HOUSING**

A high strength aluminum housing is hard anodized for superior wear and corrosion resistance.

**CYLINDER**

Precision finished aluminum alloy tubing is hard anodized for maximum wear resistance and long seal life.

**SIDE TAPPED**

Mounting Holes  
Front and rear heads

**FEMALE SHAFT**

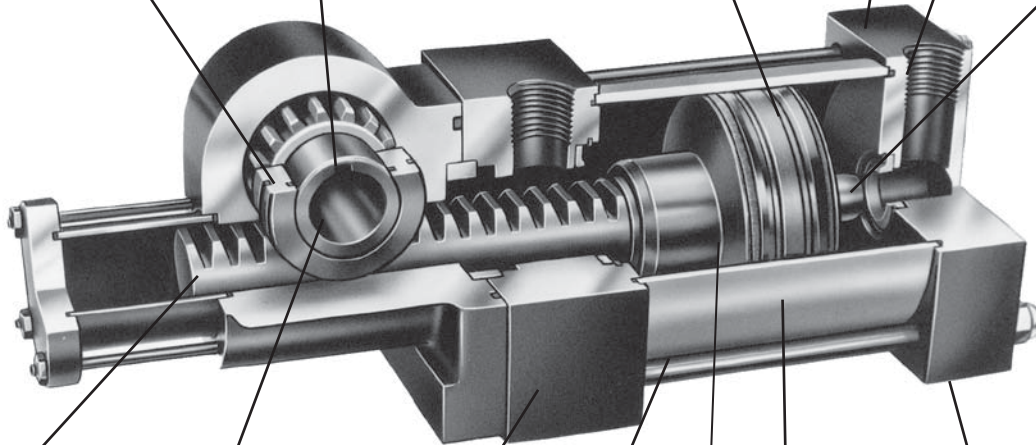
Designed for direct, on-shaft installation, eliminating the need or couplings and other connections.

**TIE RODS**

High tensile steel has precision rolled threads and black oxide coating for greater strength and fatigue resistance.

**PISTONS**

Are one piece steel for high strength and piloted to the rack assembly to ensure concentricity. A nonmetallic wear strip is employed to provide a non-scoring bearing surface. This high quality assembly eliminates friction, wear and galling while providing smooth operation.



For inventory, lead times, and kit lookup, visit [www.pdnplu.com](http://www.pdnplu.com)

H38

**Parker Hannifin Corporation**  
Pneumatic Division  
Richland, Michigan  
[www.parker.com/pneumatics](http://www.parker.com/pneumatics)

**Features**

- Standard Rotations: 90°, 180°, 360°
- Output Torque @ 100 psi: 100 lb-in to 2500 lb-in
- Maximum Break-away Pressure: 10 psi
- Mounting Orientation: Unrestricted
- Leakage: External: 0 cfm  
Internal: 0 cfm
- Theoretical Timing: Keyway located at 12:00 position at mid-stroke position of actuator

**B671 Series**

The B671 Pneumatic Rotary Actuator is designed to provide force in a reciprocating, rotational motion. It is ideal for any application requiring constant torque through a rotational distance: rotating or lifting heavy objects, positioning or bending operations.

**F672 Series**

The F672 utilizes the same high quality construction found on the B671 Series with the addition of a coupling arrangement for a Hydro-Check. An F672 / Hydro-Check assembly will provide controlled feed rates and excellent rotational control with pneumatic power through adjustable hydraulic resistance.

**B671 / F672 Series**

Pneumatic Rotary Actuator can be powered by shop air or inert gas. The actuators are pre-lubricated at assembly with NLG1 grade 2 grease with outstanding oxidation stability and corrosion resistant additives. This pre-lubrication is intended for use in pneumatic systems where airline lubrication is not used. However, to assure maximum service life of the cylinder, the air supply should be properly filtered and moisture free.

The pneumatic rotary actuator can be controlled by any conventional 4-way valve - hand, foot, mechanically or electrically controlled. All four sizes of rotary actuators are designed for direct on-shaft installation - no flexible couplings, cam and roller or chain and sprocket combinations are required.

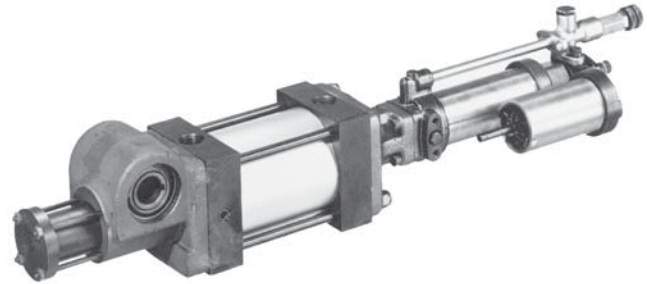
**B671 / F672 Series Cushion Option**

The standard cushions operate at the end of rotation to decelerate the actuator. A floating polyurethane cushion seal provides maximum sealing effectiveness going into the cushion. This durable material ensures millions of trouble free cycles with no wear. The cushion seal also acts as a check valve, allowing full air flow around the seal during outstroke, providing excellent break-away. Cushions, when so ordered, are installed both directions. They are available on both the B671 and F672 Series.

**Operating information**

Operating pressure (max):	140 PSIG (9.65 bar)
Temperature range:	0°F to 180°F (-17°C to 82°C)

**Hydro-Check Combination**



The Rotary Actuator/Hydro-Check combination consists of the F672 Series Actuator axially linked to an F172-2 or F172-3 Series Hydro-Check. The Hydro-Check is a precision built adjustable hydraulic resistance unit designed to provide controlled feed rates. When coupled to an actuator, excellent rotational control is attained.

The Rotary Actuator / Hydro-Check combination provides consistent torque with adjustable hydraulic resistance for a smooth controlled rotational feed rate. Axial coupling of these units eliminates eccentric loading of component parts.

These actuators are available in three torque ranges to comply with varying load requirements. The Hydro-Check is capable of checking axial loads to 3,000 lbs. and is available with many controlling options (see Ordering Information). For information on Hydro-Checks not shown in this catalog, consult factory.

**Quick Reference Data**

Model	Cylinder bore (in)	Actual output torque (lb-in) versus specified pressure (PSI)				Displacement per degree rotation (in3/°)	Maximum angular backlash (minutes)	Maximum rotational tolerance (°)
		50	75	100	125			
1	1-1/2	50	75	100	125	0.021	40	-0, +5
2	3-1/4	250	375	500	625	0.116	40	-0, +4
3	4	500	750	1000	1250	0.219	40	-0, +3
4	5	1250	1875	2500	3125	0.514	30	-0, +2

PV Series

PRN(A) Series

PTR Series

B671/F672 Series

HP Series

Rotary Actuators Products



For inventory, lead time, and kit lookup, visit [www.pdnplu.com](http://www.pdnplu.com)

Ordering Information

B671 / F672 Series Ordering Information

<b>B671</b>	<b>2</b>	<b>22</b>	<b>D</b>
-------------	----------	-----------	----------

Series	
<b>B671</b>	Pneumatic rotary actuator
<b>F672</b>	Pneumatic rotary actuator with hydro-check mounting interface

Cushions	
<b>5</b>	No cushions
<b>8</b>	Cushions both rotations

Torque Output in in-ib @ 1000 PSI	
<b>1</b>	100 *
<b>2</b>	500
<b>3</b>	1000
<b>4</b>	2500

Degrees Rotation	
<b>10</b>	90°
<b>20</b>	180°
<b>30</b>	360°

\* 100 lb-in size unit not available for F672 series

F172 Inline Hydro-Check Ordering Information  
For Use with F672 Rotary Actuator

<b>F172</b>	-	<b>20</b>	<b>10</b>	<b>3</b>
-------------	---	-----------	-----------	----------

Checking Action	
<b>20</b>	Single Acting
<b>30</b>	Double Acting

Stroke (see stroke table)	
<b>1</b>	2 in.
<b>2</b>	4 in.
<b>3</b>	6 in.
<b>4</b>	9 in.
<b>5</b>	12 in.

Hydro-Check Valve Options Single Acting	
<b>01</b>	Standard
<b>02</b>	Standard reverse acting
<b>11</b>	Stop & skip forward acting
<b>12</b>	Stop & skip reverse acting
<b>13</b>	Precision
<b>14</b>	Precision reverse acting

Hydro-Check Valve Options Double Acting	
<b>01</b>	Standard
<b>36</b>	Stop & Skip
<b>37</b>	Precision
<b>52</b>	Precision with stop & skip

Model	Nominal Torque Output (lb-in)	Rotation Range (°)	Hydro-Check Stroke Required (in)
2	500	30-140	2
		141-284	4
		285-360	6
3	1000	30-112	2
		113-227	4
		228-341	6
		342-360	9
4	2500	30-74	2
		75-151	4
		152-227	6
		228-342	9
		343-360	12

- Notes:**
- Hydro-Check must be ordered separately.
  - When both Actuator and Hydro-Check are ordered from Actuator Division, they will be assembled together.
  - Specify voltage with stop and skip function - 12, 115, 220 or 440 VAC.
  - For availability of other Hydro-Check options not listed here, please consult factory.

Service Kits – B671 / F672 \*

Actuator size (cushioned or non-cushioned)	Seal kit number
100 lb-in	<b>B732904</b>
500 lb-in	<b>B732905</b>
1,000 lb-in	<b>B732906</b>
2,500 lb-in	<b>B732907</b>

\* Does not include Hydro-Check seal kit.

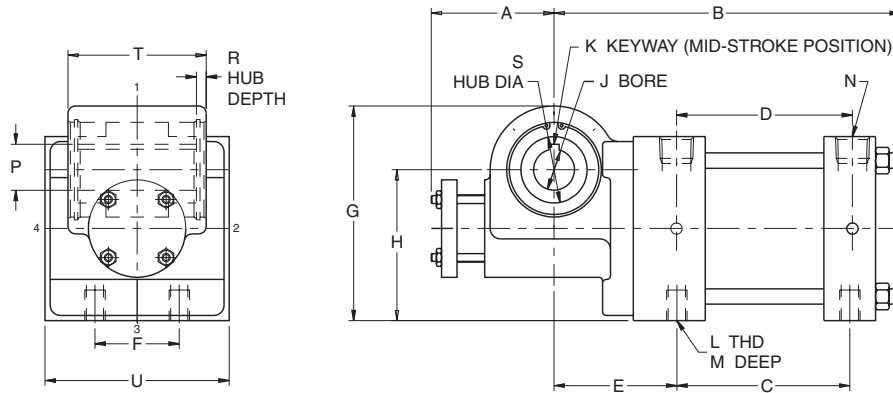


For inventory, lead times, and kit lookup, visit [www.pdnplu.com](http://www.pdnplu.com)

H40

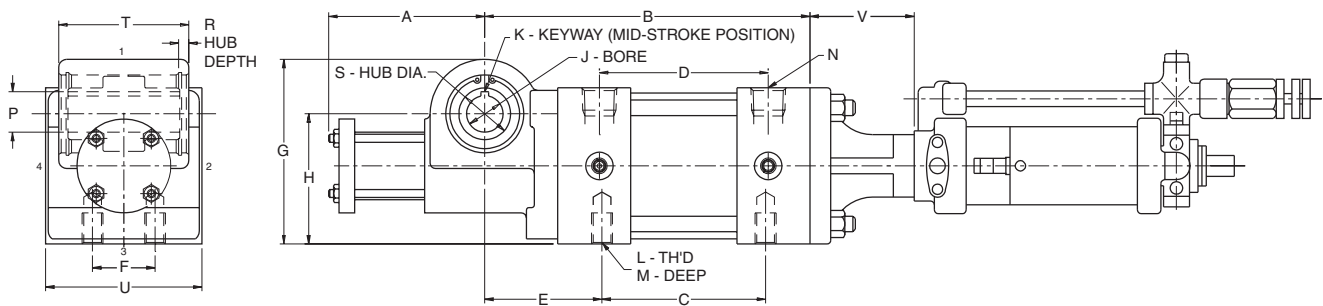
**Parker Hannifin Corporation**  
Pneumatic Division  
Richland, Michigan  
[www.parker.com/pneumatics](http://www.parker.com/pneumatics)

**B671 Series**



Model	Rotation	A	B	C	D	E	F	G	H	J	K	L	M	N	P	R	S	T	U	
1	90°	2.16	6.45	3.36	3.42															
	180°	3.35	7.53	4.44	4.50	2.19	0.62	2.94	1.92	0.500	0.12 x	1/4-20	0.38	3/8	0.560	0.16	1.00	1.69	2.00	
	360°	5.35	9.68	6.60	6.66					0.502	1.31				0.570					
2	90°	2.50	7.95	3.92	3.99															
	180°	3.75	9.21	5.17	5.25	2.81	1.50	4.44	3.12	0.875	0.19 x	1/2-13	0.75	1/2	0.964	0.22	1.25	3.12	3.75	
	360°	6.25	11.72	7.69	7.76					0.877	2.62				0.974					
3	90°	3.00	8.46	4.23	4.30															
	180°	4.56	10.03	5.80	5.87	3.00	2.06	5.25	3.69	1.000	0.25 x	1/2-13	0.75	1/2	1.117	0.24	1.62	3.38	4.50	
	360°	7.96	13.17	8.94	9.01					1.002	2.88				1.127					
4	90°	3.56	10.51	5.28	5.35															
	180°	5.75	12.87	7.63	7.71	3.88	2.69	6.88	4.75	1.500	0.38 x	5/8-11	0.94	1/2	1.668	0.31	2.50	4.12	5.50	
	360°	10.75	17.58	12.34	12.42					1.502	3.50				1.678					

**F672 Series**



**F672 Actuator with Hydro-check**

Model	Rotation	A	B	C	D	E	F	G	H	J	K	L	M	N	P	R	S	T	U	V
2	90°	2.50	7.80	3.92	4.05															
	180°	3.75	9.06	5.17	5.31	2.81	1.50	4.44	3.12	0.875	0.19 x	1/2-13	0.75	1/2	0.964	0.22	1.25	3.12	3.75	2.50
	360°	6.25	11.57	7.69	7.82					0.877	2.62				0.974					
3	90°	3.00	8.30	4.23	4.36															
	180°	4.56	9.87	5.80	5.93	3.00	2.06	5.25	3.69	1.000	0.25 x	1/2-13	0.75	1/2	1.117	0.24	1.62	3.38	4.50	2.50
	360°	7.96	13.01	8.94	9.07					1.002	2.88				1.127					
4	90°	3.56	10.22	5.28	5.41															
	180°	5.75	12.58	7.63	7.77	3.88	2.69	6.88	4.75	1.500	0.38 x	5/8-11	0.94	1/2	1.668	0.31	2.50	4.12	5.50	2.50
	360°	10.75	17.29	12.34	12.48					1.502	3.50				1.678					



For inventory, lead time, and kit lookup, visit [www.pdnplu.com](http://www.pdnplu.com)

H41

**Parker Hannifin Corporation**  
 Pneumatic Division  
 Richland, Michigan  
[www.parker.com/pneumatics](http://www.parker.com/pneumatics)

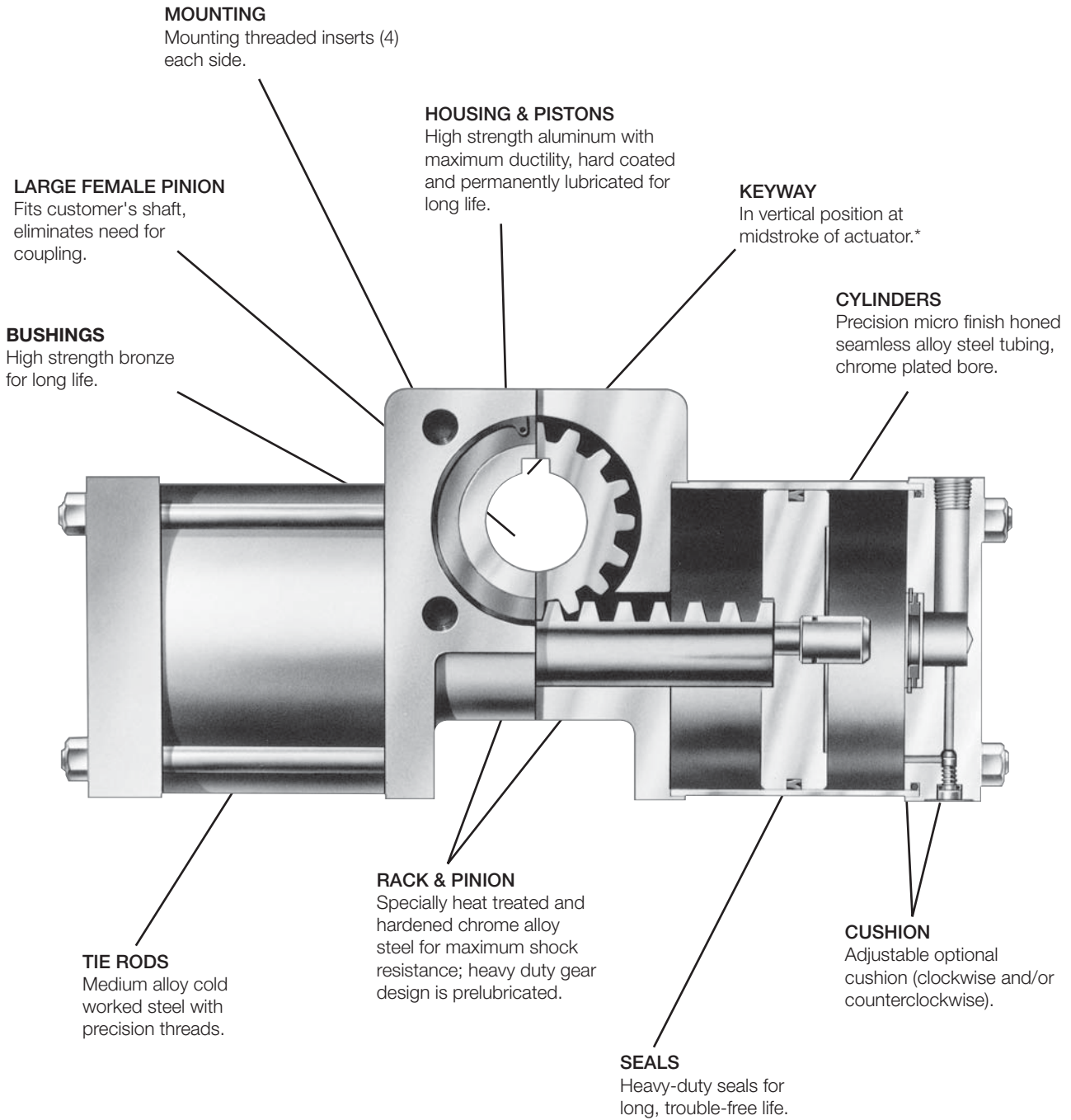
PV Series  
 PRN(A) Series  
 PTR Series  
 B671/F672 Series  
 HP Series  
 Rotary Actuators Products



Features

HP Series

PV Series
PRN(A) Series
PTR Series
B671/F672 Series
HP Series
Rotary Actuators Products
<b>H</b>



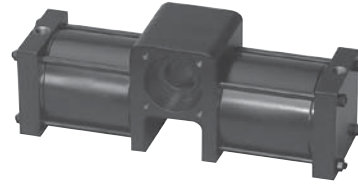
For inventory, lead times, and kit lookup, visit [www.pdnplu.com](http://www.pdnplu.com)

H42

**Parker Hannifin Corporation**  
Pneumatic Division  
Richland, Michigan  
[www.parker.com/pneumatics](http://www.parker.com/pneumatics)

Features

- Rack and pinion rotary actuator
- 2 large bore models
- 3 standard rotations: 90°, 180°, 360°
- Standard output torque at 100 PSIG: 4,500 and 10,000 lb-in
- Large female pinion
- Available with adjustable cushions and stroke adjusters



Operating information

Operating pressure:	100 PSIG (6.9 bar)
Temperature range:	
Nitrile seals	0°F to 180°F (-18° to 82°C)
Fluorocarbon seals	0°F to 250°F (-18° to 121°C)
Filtration requirements:	40 micron, dry filtered air

Ordering information

**HP 10 - 090 3 C - A A 2 V -**

**Model**

4.5	4,500 lb-in output torque
10	10,000 lb-in output torque

**Rotation<sup>1</sup>**

090	90°
180	180°
360	360°

Specify other rotations.

**Special options**

Omit	Standard
------	----------

Two digit code assigned by factory when any "X" or "9" appears in the model number or when special options or features are required.

**Cushions**

Omit	None
1	CW rotation <sup>2</sup>
2	CCW rotation <sup>2</sup>
3	Both rotation
9	Special

**Seals**

Omit	Nitrile (standard)
V	Fluorocarbon
X	Special

**Stroke adjusters**

Omit	None
A	0-5° CW rotation <sup>2</sup>
B	0-5° CCW rotation <sup>2</sup>
C	0-5° both rotation
D	0-30° CW rotation <sup>2,3</sup>
E	0-30° CCW rotation <sup>2,3</sup>
F	0-30° both rotation <sup>3</sup>
X	Special

**Port type**

2	NPTF (standard)
9	Special

**Shaft configuration**

A	Female keyed shaft
B	Male keyed shaft
D	Female SAE 10B spline
E	Male SAE 10B spline
X	Special

**Mounting style**

A	Face (standard)
X	Special

**Notes:**

<sup>1</sup> To obtain equal rotation both sides of midstroke (theoretical 12:00), order 5° longer rotation than standard with stroke adjusters.

<sup>2</sup> Viewed from shaft end.

<sup>3</sup> Cannot combine with cushions.

**Sensors**  
See section L for sensors.

PV Series  
 PRN(A) Series  
 PTR Series  
 B671/F672 Series  
 HP Series  
 Rotary Actuators Products



**Quick reference data**

Model	Rotation* (Degrees)	Displacement (Cubic inches)	Weight (lb)	Bore size	Actual torque output at 100 psi (lb-in)	Maximum rotational tolerance (degrees)	Maximum angular backlash (minutes)
4.5	90°	79.93	63	6"	4,500	-0, +2	15
	180°	159.86	75				
	360°	319.72	95				
10	90°	177.64	125	8"	10,000	-0, +2	15
	180°	355.28	147				
	360°	710.56	190				

\* To obtain equal rotation both sides of midstroke (theoretical 12:00), order 5° longer rotation than standard with stroke adjusters.

**Bearing load capacities and kinetic energy ratings**

Model	Radial load (lb) per bearing		Thrust load (lb)		Distance between bearings (in.)	Maximum kinetic energy rating for models based on configuration (in-lb)		
	Dynamic	Static	Dynamic	Static		Standard	Stroke adjusters	Cushion
4.5	2,000	3,000	300	450	2.77	45	45	650
10	2,000	3,000	500	750	3.63	100	100	1,450

**Seal kit ordering information**

- Standard units are equipped with Nitrile seals.
- Optional seal compounds are available.
- Seal kit part numbers as shown:

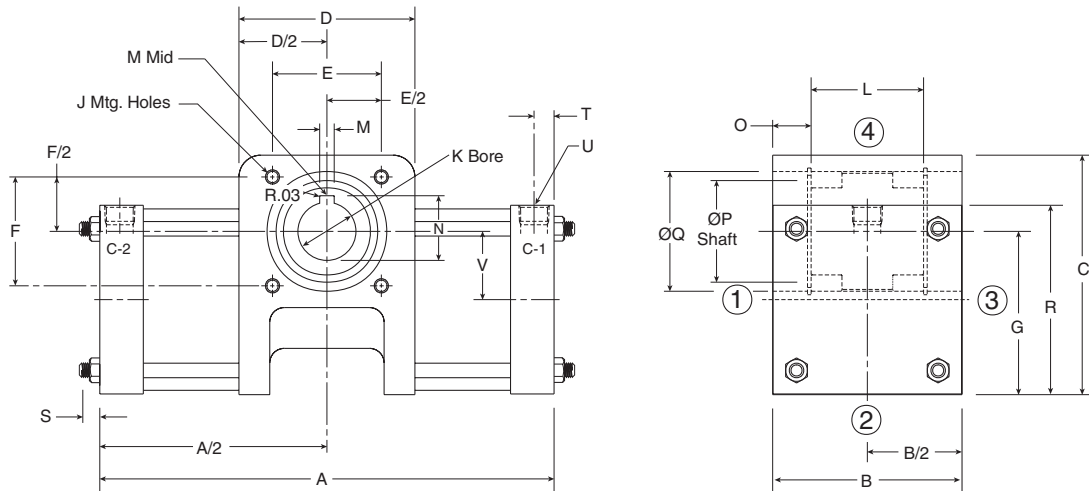
<b>PSK</b> Parker seal kit	—	<b>HP4.5</b> Base model	<b>V</b>	
			Omit	Standard
			V	Fluorocarbon
			N	Non-Lube

PV Series  
 PRN(A) Series  
 PTR Series  
 B671/F672 Series  
 HP Series  
 Rotary Actuators Products





**Standard face mount (A) and female keyed shaft (A) shown**



**Notes:** Pressure on C-1 port gives clockwise rotation.  
 Pressure on C-2 port gives counterclockwise rotation.

Numbers above represent possible mounting and port positions.

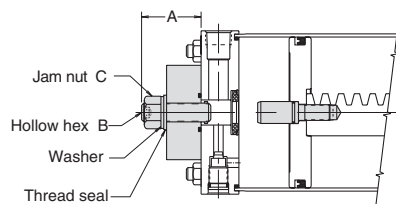
Model	Rotation (Degrees)	A	B	C	D	E	F	G	J	K
4.5	90°	15-5/8								
	180°	22-1/4	6.525	8-1/4	6.063	3.750	3.750	5.615	7/16-14 x 21/32 DP	2.000
	360°	33								2.003
10	90°	18								
	180°	26-3/4	8.525	10-1/2	7.813	5.000	5.000	7.265	5/8-11 x 15/16 DP	2.250
	360°	39-5/8								2.253

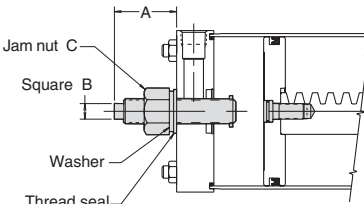
Mode	L	M	N	O	P	Q	R	S	T	U	V
4.5	3-7/8	0.500	2.223	1-5/16	3-1/2	4-1/8	6-1/2	5/8	0.69	3/4 NPTF	2.35
		0.502	2.233								
10	5	0.625	2.525	1-3/4	4-1/2	5-1/4	8-1/2	3/4	0.69	3/4 NPTF	3.00
		0.628	2.535								

**Stroke Adjusters (A - F)**

5° stroke adjust option with cushion option



5° or 30° stroke adjust option without cushion option

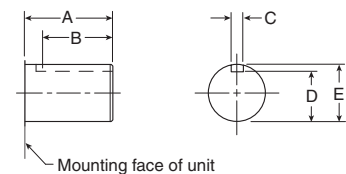


**Cushioned end cap**

Model	(1) Turn Adjust	A			(1) Turn Adjust	A			
		A	B	C		5°	30°	B	C
4.5	2.5°	2.50	5/8	1.00-14	2.0°	2.00	2.81	3/8	3/4-16
10	2.0°	2.50	15/16	1.50-12	1.5°	2.56	3.50	15/16	1-1/2-12

**Non-cushioned end cap**

**Male Shaft (B)**



Model	A	B
4.5	2.61	2.38
10	4.38	3.38

Model	C	D	E
4.5	0.561	1.928	2.249
	0.562	1.933	2.250
10	0.625	1.888	2.249
	0.627	1.893	2.250



For inventory, lead time, and kit lookup, visit [www.pdnplu.com](http://www.pdnplu.com)

H45

**Parker Hannifin Corporation**  
 Pneumatic Division  
 Richland, Michigan  
[www.parker.com/pneumatics](http://www.parker.com/pneumatics)

PV Series  
 PRN(A) Series  
 PTR Series  
 B671/F672 Series  
 HP Series  
 Rotary Actuators Products

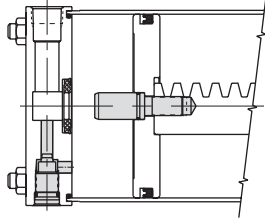


**Options**

PV Series  
 PRN(A) Series  
 PTR Series  
 B671/F672 Series  
 HP Series  
 Rotary Actuators Products

**Cushions (1, 2, 3)**

The standard cushions operate over the last 20° of rotation in either direction. A floating bushing ensures no binding of cushion spear. All cushions are fully adjustable and are located on the side opposite the port. For other cushion locations specify "9" and describe.



**Proximity Sensors**

**(Namco Cylinders or Balluff Cylinder Indicator Sensor)**

The inductive type proximity sensor provides end of rotation indication. The non-contact probe senses the presence of the ferrous cushion spear and has no springs, plungers, cams or dynamic seals that can wear out or go out of adjustment. The sensor is solid state and meets NEMA 1, 12 & 13 specifications. For ease of wiring the connector housing is rotatable through 360°. To rotate, lift the cover latch, position and release.

The sensor make/break activation point may occur at 0.125" to ±0.125" from the end of stroke. Depending on the actuator size, this distance may cause activation at 2° to 15° from end of stroke.

The standard proximity sensor controls 50-230 VAC/DC loads from 5 to 500 mA. The low 1.7 mA off-state leakage current can allow use for direct PLC input. The standard short circuit protection (SCP) protects the sensor from a short in the load or line upon sensing such a condition (5 amp or greater current) by assuming a non-conductive mode. The fault condition must be corrected and the power removed to reset the sensor preventing automatic restarts.

The low voltage DC sensor is also available for use with 10-30 VDC. The sensor is in a non-rotatable housing, but does incorporate the short circuit protection.

Both sensors are equipped with two LEDs, "Ready" and "Target". The "Ready" LED is lit when power is applied and the cushion spear is not present. The "Target" LED will light and the "Ready" LED will go out when the sensor is closed, indicating the presence of the cushion spear. Both LEDs flashing indicates a short circuit condition.

**NOTES:**

1. Available with or without cushions.
2. Not available with stroke adjusters.
3. Pressure rating: 3000 psi
4. Operating temperature: -4°F to 158°F
5. Specify sensor type, orientation and voltage when ordering.
6. The low voltage DC sensor is available in non-rotatable style only; consult factory for further information.

**Rotary Actuators  
 HP Series**

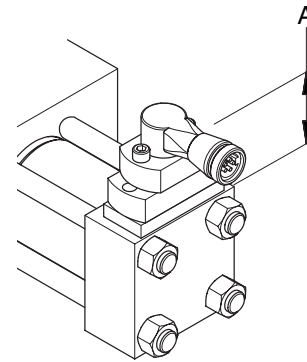
**Additional Shaft Options (D, E)**

Hollowed key shaft is standard. Additional shaft options available are available as a special. Consult factory for information.

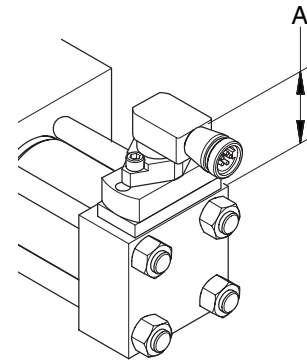
- Male splined (E)
- Female splined (D)

**Fluorocarbon Seals (V)**

Standard abrasion resistant nitrile seals should be used for general purpose applications with temperatures of 0 to 180°F. Fluorocarbon seals are recommended for high temperature applications up to 250°F.



EPS-6



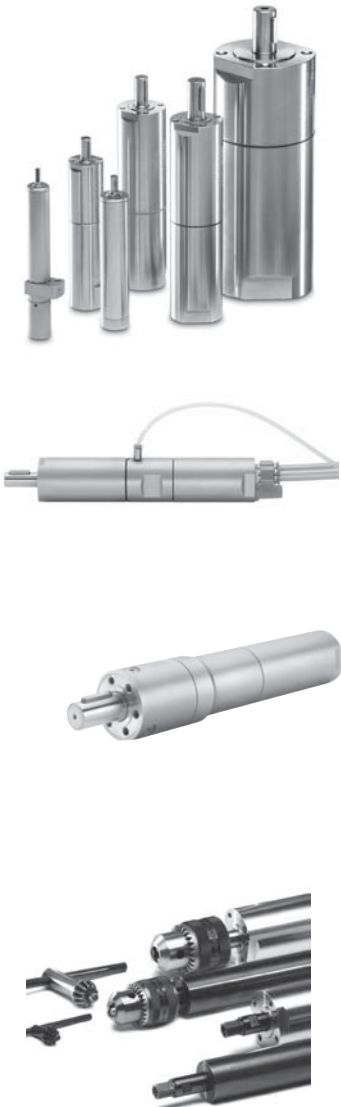
EPS-7

Model	A (max)
	EPS-6 & 7
4.5	1.59
10	2.28

Order proximity sensors separately. See Electronic Sensors section for specifications and ordering information.



For inventory, lead times, and kit lookup, visit [www.pdnplu.com](http://www.pdnplu.com)



## Stainless Steel Air Motors P1V-S Series

<b>Overview</b>	J2-J10
<b>Stainless Steel – 0.02 to 1.2 kW</b>	
Features	J11-J12
Overview	J13
Technical Data	J14-J15
Order Key	J16
Specifications	J17-J31
20, 30, 80, 120, 200, 300, 600, 900, 1200 Watts	

<b>Stainless Steel with Brakes</b>	
Features	J32
Technical Data	J33
Specifications	J34-J39
200, 300, 1200 Watts	

<b>High Torque Stainless Steel – 0.28, 0.57 &amp; 0.86 kW</b>	
Technical Data	J41
Specifications	J42-J47
285, 570, 860 Watts	
Accessories	J48
Service	J49-J51
ATEX Directive	J52-J56

<b>Drilling, Milling &amp; Grinding Type – 0.08 to 1 kW</b>	
Features	J57
Order Key	J57
Technical Data	J58-J59
Specifications	J60-J66
Drilling Motors – 80, 170, 250, 400, 600 Watts	
Accessories	J67
Grinding Motors – 90, 150, 250, 300 Watts	
Milling Motors – 400, 500, 700, 1000 Watts	
Service & Kits	J72



**Overview**

	Features	Air motor	Hydraulic motor	Electric motor	Electric motor regulated	Electric motor regulated with feedback
Stainless Steel	Overload safe	***	***	*	**	***
	Increased torque at higher loads	***	**	*	**	***
	Easy to limit torque	***	***	*	*	***
Stainless Steel with Brakes	Easy to vary speed	***	***	*	***	***
	Easy to limit power	***	***	*	**	***
	Reliability	***	***	***	***	***
High Torque Stainless Steel	Robustness	***	***	*	*	*
	Installation cost	***	*	**	**	**
	Ease of service	***	**	*	*	*
	Safety in damp environments	***	***	*	*	*
Drilling, Milling & Grinding	Safety in explosive atmospheres	***	***	*	*	*
	Safety risk with electrical installations	***	***	*	*	*
	Risk of oil leak	***	*	***	***	***
	Hydraulic system required	***	*	***	***	***
	Weight	**	***	*	**	*
	Power density	**	***	*	*	*
	High torque for size	**	***	*	*	*
Air Motors	Noise level during operation	*	***	**	**	**
	Total energy consumption	*	**	***	***	***
	Service interval	*	**	***	***	***
	Compressor capacity required	*	***	***	***	***
	Purchase price	*	*	***	***	**
	Accuracy, speed	*	**	*	**	***
	Regulating dynamic	*	*	*	*	***
	Communication	*	*	*	***	***

\* = good, \*\*= average, \*\*\*= excellent



**Important**

Before carrying out service activities, make sure the air motor is vented. Before disassembling the motor, disconnect the primary air hose to ensure that the air supply is interrupted.



**Note**

All technical data in the catalog are typical values. The air quality is a major factor in the service life of the motor, see ISO 8573-1.



For inventory, lead times, and kit lookup, visit [www.pdnplu.com](http://www.pdnplu.com)

## P1V-S Series

### Choosing the correct air motor for your application

#### 1 Which drive principle of the air motor is suitable for your application?

- Air vane motor are suitable for regular operating cycles, speed is very small e.g. 16 rpm
- Tooth gear air motor or turbines are more suitable for continuous operation, 24 hours non-stop, speed is in an upper range, up to 140,000 rpm
- Oil free operation is often an option for these three principles of air motors.

#### 2 Which motor materials are suitable for your application?

- Will the air motor work in a normal production area
- Or in a paper industry
- Or in the food processing industry, in contact or not with food
- Or in underwater usage
- Or in the medical, pharmaceutical industries
- Or in potentially explosive areas
- Others, please describe your environment

#### 3 How do you calculate the motor power taking the application conditions into consideration?

1. Which rotational direction? Clockwise, counter-clockwise, reversible?
2. Air pressure working range? Which air class quality is available?
3. Which torque and which speed under load do you expect to obtain?
4. Calculate the basic power with the formula

$$P = M \times n / 9550 \text{ with } P \text{ power output in kW, } M \text{ nominal torque in Nm, } n \text{ nominal speed in rpm}$$

5. Check performance data of air motors in our catalogs. Note that all data is at 6 bar in the inlet of the air motor, max 3 meters for tubes and oil lubricated operations.
6. To adapt the difference of air pressure with your operation conditions, please check graphs in our catalogs and how to do it.
7. or you can adapt the need of air to fit your operation conditions by throttling the outlet flow in the air motor you will reduce speed without loss of torque.
8. Check if you need an oil free or not working operation. 1 to 2 drops of oil per cube meter are needed to optimize performance and life time of air motors. Oil free operation will decrease by 10 to 15% the performance of air motors.

#### 4 How do you integrate your air motor in your system?

- In which position is the air motor used?
- Do you need to use a brake?
- Do you want to use your own gear box and put it somewhere else in the machine?
- Do you need extra components like fittings, tubes, valves and FRLs?

#### 5 How do you ensure a long life and high performance of the air motor?

- Ensure your air quality is in accordance with our specifications, oil or oil free lubrication operations.
- Keep the recommended maintenance intervals

#### 6 How do you determine the purchasing and running costs after the air motor installation?

- Keep same level of your air quality.

Stainless Steel

Stainless Steel  
with BrakesHigh Torque  
Stainless SteelDrilling, Milling &  
Grinding

Air Motors

J



For inventory, lead time, and kit  
lookup, visit [www.pdnplu.com](http://www.pdnplu.com)

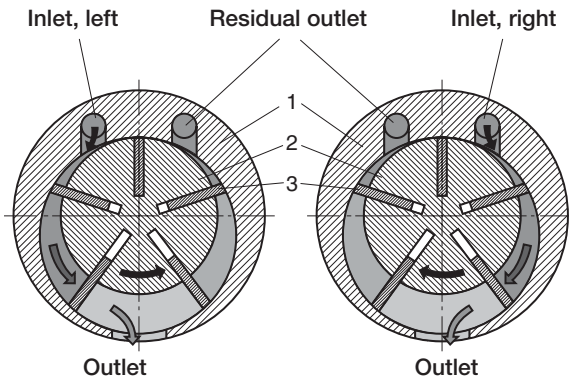
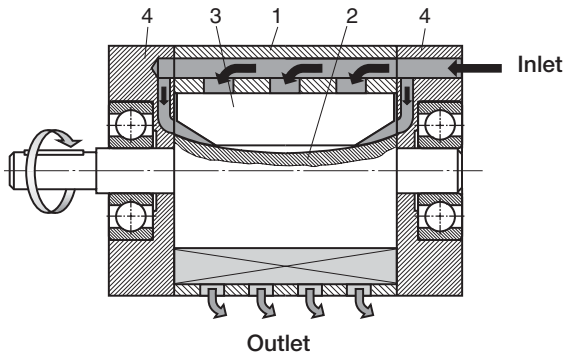
J3

**Parker Hannifin Corporation**  
Pneumatic Division  
Richland, Michigan  
[www.parker.com/pneumatics](http://www.parker.com/pneumatics)

**Overview**

**Air Motors  
P1V-S Series**

**Principles of motor functioning**

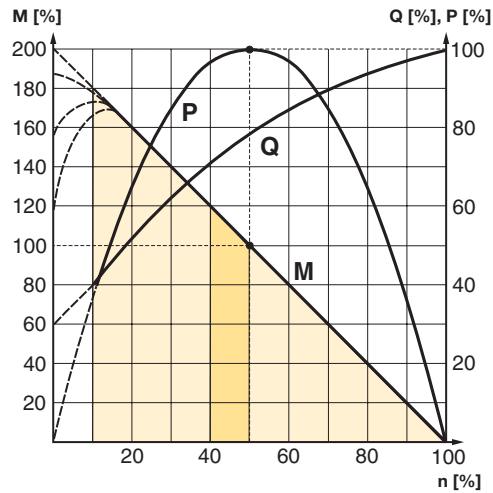


- 1 - Rotor cylinder
- 2 - Rotor
- 3 - Vanes
- 4 - End piece with bearing

There are a number of designs of air motors. Parker has chosen to use the vane rotor design, because of its simple design and reliable operation. The small external dimensions of vane motors make them suitable for all applications.

The principle of the vane motor is that a rotor with a number of vanes is enclosed in a rotor cylinder. The motor is supplied with compressed air through one connection and air escapes from the other connection. To give reliable starting, the springs press the vanes against the rotor cylinder. The air pressure always bears at right angles against a surface. This means that the torque of the motor is a result of the vane surfaces and the air pressure.

**Torque, power and air consumption graphs**



The curve is for 6 bar  
**P = power**      **Q = air consumption**  
**M = torque**      **n = speed**

- Possible working range of motor.
- Optimum working range of motor.  
 Higher speeds = more vane wear  
 Lower speeds with high torque = more gearbox wear

The performance characteristics of each motor are shown in a family of curves as above, from which torque, power and air consumption can be read off as a function of speed. Power is zero when the motor is stationary and also when running at free speed (100%) with no load. Maximum power (100%) is normally developed when the motor is driving a load at approximately half the free speed (50%).

Torque at free speed is zero, but increases as soon as a load is applied, rising linearly until the motor stalls. As the motor can then stop with the vanes in various positions, it is not possible to specify an exact torque. However, a minimum starting torque is shown in all tables.

Air consumption is greatest at free speed, and decreases with decreasing speed, as shown in the above diagram.



For inventory, lead times, and kit lookup, visit [www.pdnplu.com](http://www.pdnplu.com)

## Overview

### Introduction

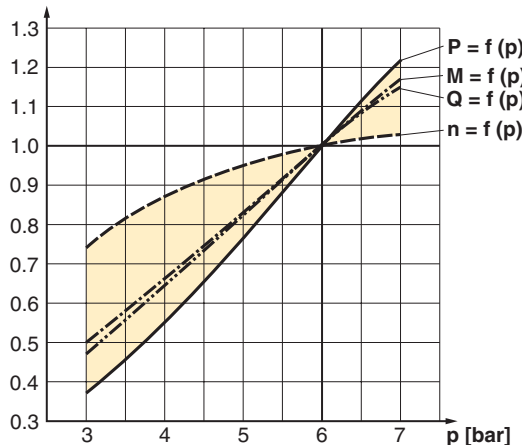
The performance of an air motor is dependent on the inlet pressure. At a constant inlet pressure, air motors exhibit the characteristic linear output torque / speed relationship. However, by simply regulating the air supply, using the techniques of throttling or pressure regulation, the output of an air motor can easily be modified. The most economical operation of an air motor (least wear, least air consumption, etc.) is reached by running close to nominal speed. By torque of  $M = 0$ , the maximum speed (idle speed) is reached. Shortly before standstill ( $n = 0$ ), the air motor reaches its maximum torque ( $M_{max} = 2 \times M_0$ ). At nominal speed ( $nn$ ), for example in the middle of the speed range, air motor reaches its maximum power output ( $P_{max}$ ).

### Energy Efficiency

A pneumatic motor achieves its maximum power when it is operating as close as possible to its rated speed (50% of the rated idle speed). The energy balance is best in this area, because the compressed air is used efficiently.

### Air pressure correction factors

To adapt the difference of air pressure with your operation conditions.



P = Power, M = Torque, Q = Air consumption, N = Speed

## Air Motors P1V-S Series

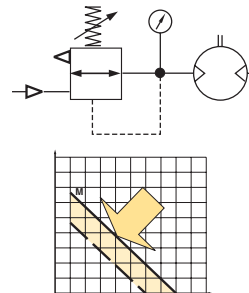
Pressure (p) bar / PSI	Power (P) %	Speed (n) %	Torque (M) %	Air Consumpt. (Q) %
7 / 99	121	103	117	117
6 / 85	100	100	100	100
5 / 71	77	95	83	83
4 / 57	55	87	67	67
3 / 42	37	74	50	50

All catalog data and curves are specified at a supply pressure of 6 bar to the motor. This diagram shows the effect of pressure on speed, specified torque, power and air consumption.

Start off on the curve at the pressure used and then look up to the lines for power, torque and air consumption. Read off the correction factor on the Y axis for each curve and multiply this by the specified catalog data in the table, or data read from the torque and power graphs.

Example: at 4 bar supply pressure, the power is only 0.55 x power at 6 bar supply pressure. This example shows how strongly power falls if supply pressure is reduced. You must therefore ensure that the motor is supplied through pipes of sufficient diameter to avoid pressure drop.

The speed and torque can also be regulated by installing a pressure regulator in the inlet pipe. This means that the motor is constantly supplied with air at lower pressure, which means that when the motor is braked, it develops a lower torque on the output shaft.



### Speed regulation, air flow reduction

Every size reduction or restriction on the air line, whether of the supply hose itself or fittings, before the air motor affects the amount of the supplied air. By throttling you reduce the speed of your motor and simultaneously, the required torque. That means that you reduce the motor performance. The most common way to reduce the speed of a motor is to install a flow control valve in the air outlet, you can set the speed without loss of the torque. When the motor is used in applications where it must reverse and it is necessary to restrict the speed in both directions, flow control valves with by-pass should be used in both directions. If the inlet air is restricted, the air supply is restricted and the free speed of the motor falls, but there is full pressure on the vanes at low speeds. This means that we get full torque from the motor at low speeds despite the low air flow. Since the torque curve becomes "steeper", this also means that we get a lower torque at any given speed than would be developed at full air flow. The benefit of throttling the inlet is that air consumption is reduced, whereas throttling the exhaust air maintains a slightly higher starting torque.

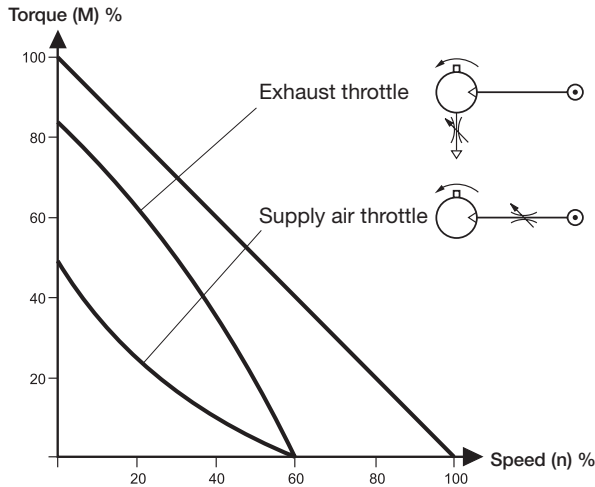


For inventory, lead time, and kit lookup, visit [www.pdnplu.com](http://www.pdnplu.com)

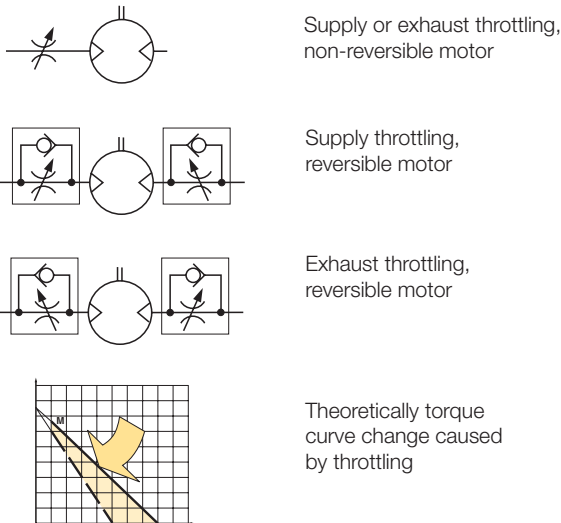
**Overview**

**Air Motors  
P1V-S Series**

- Stainless Steel
- Stainless Steel with Brakes
- High Torque Stainless Steel
- Drilling, Milling & Grinding
- Air Motors

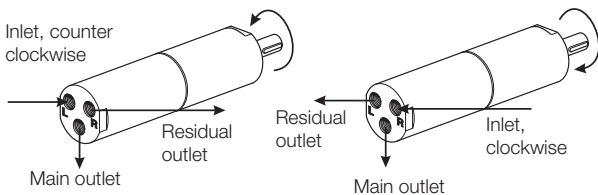


**Throttling**



**Component choice for air supply**

**Direction of motor rotation**



The direction of rotation of reversible motors is controlled by supplying inlet L or inlet R with compressed air. Air motors can be stopped and started continually without damage.

As the motor begins to rotate air is trapped between the vanes and is compressed. This air is exhausted through the exhaust port. As the rotor continues its rotation, trapped air is compressed and exhausted through the residual port. If this air is not exhausted, the motor will be braked and maximum power will not be obtained.

**Compressed air quality**

Oil and oil mist are avoided whenever possible to ensure a clean work environment. In addition, purchasing, installation and maintenance of oil equipment can be expensive. All users in all industries now try to avoid using components which have to be lubricated. The P1V air motors series are equipped with vanes for intermittent lubrication free operation as standard, which is the most common application of air motors.

**Dry unlubricated compressed air**



If unlubricated compressed air is used, the compressed air should comply with the purity standards below in order to guarantee the longest possible overall service life. If the unlubricated compressed air has a high water content, condensation forms inside the motor, causing corrosion in all internal components. A ball bearing can be destroyed in a remarkably short time if it comes into contact with a single water droplet. For indoor use, we recommend ISO8573-1 purity class 3.4.1. To achieve this, compressors must be fitted with after coolers, oil filters, refrigerant air dryers and air filters. For indoor/outdoor use, we recommend ISO8573-1 purity class 1.2.1.

To achieve this, compressors must be fitted with after coolers, oil filters, adsorption dryers and dust filters.

**Oil mist**



If oil mist is used (approx. 1 drop of oil per m<sup>3</sup> of compressed air), the oil not only acts as a lubricant but also protects against corrosion. This means that compressed air with a certain water content may be used without causing corrosion problems inside the motor. ISO8573-1 purity class 3.-.5 may be used without difficulty. The following oils are recommended for use in the food stuffs industry: Shell Cassida Fluid HF 32 or Klüberoil 4 UH 1-32

**ISO 8573-1 purity classes**

Quality class	Contaminants		Water	Oil
	particle size (µm)	max. concentration (mg/m <sup>3</sup> )	max. pressure dew point (°C)	max. concentration (mg.m <sup>3</sup> )
1	0.1	0.1	-70	0.01
2	1	1	-40	0.1
3	5	5	-20	1.0
4	15	8	+3	5.0
5	40	10	+7	25
6	-	-	+10	-

For example: compressed air to purity class 3.4.3. This means a 5 µm filter (standard filter), dew point +3°C (refrigerant cooled) and an oil concentration of 1,0 mg oil/m<sup>3</sup> (as supplied by a standard compressor with a standard filter).



For inventory, lead times, and kit lookup, visit [www.pdnplu.com](http://www.pdnplu.com)



## Overview

### Air supply

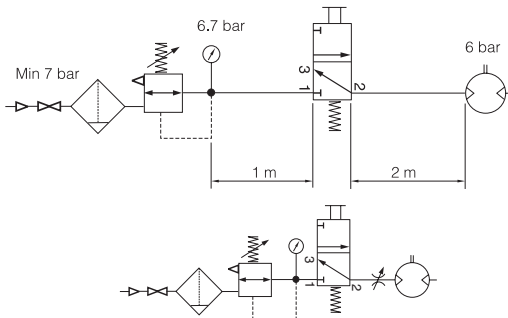
Since the supply pressure at the air motor inlet port is of considerable importance for obtaining the power, speed and torque quoted in the catalog, the recommendations below should be observed.

The following data must be complied with:

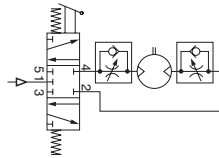
- Supply pressure: 7 bar
- Regulator pressure setting: 6.7 bar
- Pipe length between air treatment unit and valve: max. 1 m
- Pipe length valve and air motor: max 2 m

The pressure drop through the air preparation unit, pipe, valve means that 6 bar pressure is obtained at the motor supply port. Please refer to the correction diagram and factors to see what lower supply pressure means for power, speed and torque.

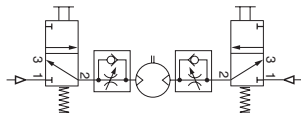
Shut-off, filtering, pressure regulation and control valve



Reversible motor with 5/3 control valve



Reversible motor with two 3/2 control valves



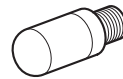
The air with which the motor is supplied must be filtered and regulated. Directional valves are needed to provide it with air, to get the motor to rotate when we want it to. These valves can be equipped with several means of actuation, such as electric, manual and pneumatic control. When the motor is used in a non-reversible application, it is sufficient to use a 2/2 or 3/2 valve function for supply. Either one 5/3 or two 3/2 valves functions are needed for a reversible motor, to ensure that the motor receives compressed air and the residual air outlet is vented. A flow control valve can be installed in the supply pipe to regulate the motor speed if the motor is not used as a reversible motor.

One flow control valve with by-pass is needed to regulate each direction of rotation if the motor is used as a reversible motor. The built-in check valve will then allow air from the residual air outlet to escape through the outlet port in the control valve. The compressed air supply must have sufficiently large pipes and valves to give the motor the maximum power. The motor needs 6 bar at the supply port all the time. For example, a reduction of pressure to 5 bar reduces the power developed to 77% and to 55% at 4 bar!

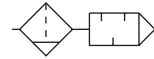
## Air Motors P1V-S Series

### Silencing

Exhaust silencer



Central silencer



The noise from an air motor consists of both mechanical noise and a pulsating noise from the air flowing out of the outlet. The installation of the motor has a considerable effect on mechanical noise. It should be installed so that no mechanical resonance effects can occur. The outlet air creates a noise level which can amount to 115 dB(A) if the air is allowed to exhaust freely into the atmosphere. Various types of exhaust silencers are used to reduce this level. The most common type screws directly onto the exhaust port of the motor. Since the motor function causes the exhaust air to pulsate, it is a good idea to allow the air to exhaust into some kind of chamber first, which reduces the pulsations before they reach the silencer. The best silencing method is to connect a soft plastic hose to a large central silencer with the largest possible area, to reduce the speed of the out-flowing air as far as possible.

**NOTE!** Remember that if a silencer which is too small or is blocked, generates back pressure on the outlet side of the motor, which reduces the motor power.

### CE marking

The air motors are supplied as “Components for installation” – the installer is responsible for ensuring that the motors are installed safely in the overall system. Parker Pneumatic guarantees that its products are safe, and as a supplier of pneumatic equipment we ensure that the equipment is designed and manufactured in accordance with the applicable EU directive.

Most of our products are classed as components as defined by various directives, and although we guarantee that the components satisfy the fundamental safety requirements of the directives to the extent that they are our responsibility, they do not usually carry the CE mark. Nevertheless, most P1V-S motors carry the CE mark because they are ATEX certified (for use in explosive atmospheres).

The following are the currently applicable directives:

- Machinery Directive (essential health and safety requirements relating to the design and structure of machines and safety components)
- EMC Directive
- Simple Pressure Vessels Directive
- Low Voltage Directive
- ATEX Directive (ATEX = ATmosphere EXplosive)



For inventory, lead time, and kit lookup, visit [www.pdnplu.com](http://www.pdnplu.com)

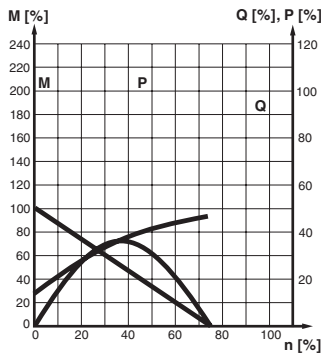


Overview

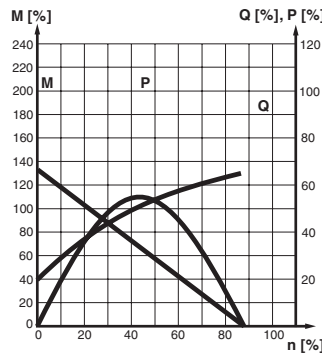
Torque, power and air consumption graphs

- Stainless Steel
- Stainless Steel with Brakes
- High Torque Stainless Steel
- Drilling, Milling & Grinding
- Air Motors

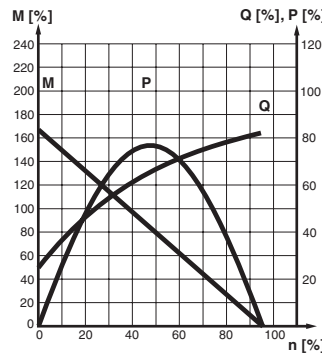
3 bar



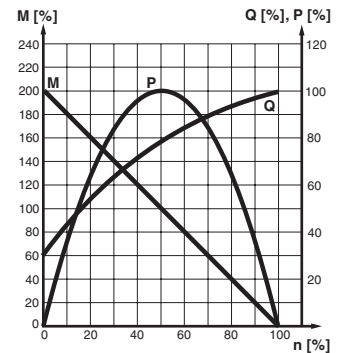
4 bar



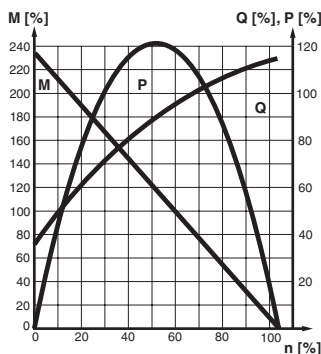
5 bar



6 bar



7 bar



The curve is for 6 bar  
**P = power**  
**M = torque**  
**Q = air consumption**  
**n = speed**

The curves in this graph are a combination of the torque, power and air consumption graphs. The values from the correction diagram have also been used for the curves for the different pressure values. The graph also shows that it is very important to ensure that the pressure supplied to the inlet port of the motor is correct, in order to allow the motor to work at maximum capacity. If the valve supplying a large motor is too small or if the supply line is under specified, the pressure at the inlet port may be so low that the motor is unable to do its work. One solution would be to upgrade the valve and supply system, or alternatively you could replace the motor with a smaller motor with lower air consumption. The result would be increased pressure at the inlet port, which means that the smaller motor could carry out the necessary work. However, you may need to select a smaller motor with a lower free speed in order to obtain sufficient torque at the outgoing shaft.

Choice of an air motor, general

The motor to be used should be selected by starting with the torque needed at a specific spindle speed. In other words, to choose the right motor, you have to know the required speed and torque. Since maximum power is reached at half the motor's free speed, the motor should be chosen so that the point aimed at is as close as possible to the maximum power of the motor.

The design principle of the motor means that higher torque is generated when it is braked, which tends to increase the speed. This means that the motor has a kind of speed self regulation function built in. Use the following graph to choose the correct motor size and the correct type of gear as appropriate. The graph contains the points for the maximum torque of each motor at maximum power. Put in your point on the graph and select a marked point above and to the right of the point you need.

Then check the characteristic graph of each motor to find more accurate technical data. Always select a motor where the data required is in the orange field. Also use the correction diagram to see what it would mean to use different air supply pressures or different air flow in the motor.

**Tip:** Select a motor which is slightly too fast and powerful, regulate its speed and torque with a pressure regulator and/or restriction to achieve the optimum working point.

Do you need any support to select the right air motor, please feel free to consult your local sales office.



For inventory, lead times, and kit lookup, visit [www.pdnplu.com](http://www.pdnplu.com)

**Overview**

**Specifying air quality (purity) in accordance with ISO8573-1:2010, the international standard for Compressed Air Quality**

ISO8573-1 is the primary document used from the ISO8573 series as it is this document which specifies the amount of contamination allowed in each cubic metre of compressed air.

ISO8573-1 lists the main contaminants as Solid Particulate, Water and Oil. The purity levels for each contaminant are shown separately in tabular form, however for ease of use, this document combines all three contaminants into one easy to use table.

ISO8573-1:2010 CLASS	Solid Particulate			Mass Concentration mg/m <sup>3</sup>	Water		Oil
	0.1 - 0.5 micron	0.5 - 1 micron	1 - 5 micron		Vapor Pressure Dewpoint	Liquid g/m <sup>3</sup>	Total Oil (aerosol liquid and vapor) mg/m <sup>3</sup>
0	As specified by the equipment user or supplier and more stringent than Class 1						
1	≤ 20,000	≤ 400	≤ 10	-	≤ -70 °C	-	0.01
2	≤ 400,000	≤ 6,000	≤ 100	-	≤ -40 °C	-	0.1
3	-	≤ 90,000	≤ 1,000	-	≤ -20 °C	-	1
4	-	-	≤ 10,000	-	≤ +3 °C	-	5
5	-	-	≤ 100,000	-	≤ +7 °C	-	-
6	-	-	-	≤ 5	≤ +10 °C	-	-
7	-	-	-	5 - 10	-	≤ 0.5	-
8	-	-	-	-	-	0.5 - 5	-
9	-	-	-	-	-	5 - 10	-
X	-	-	-	> 10	-	> 10	> 10

**Specifying air purity in accordance with ISO8573-1:2010**

When specifying the purity of air required, the standard must always be referenced, followed by the purity class selected for each contaminant (a different purity class can be selected for each contamination if required).

An example of how to write an air quality specification is shown below:

**ISO 8573-1:2010 Class 1.2.1**

ISO 8573-1:2010 refers to the standard document and its revision, the three digits refer to the purity classifications selected for solid particulate, water and total oil. Selecting an air purity class of 1.2.1 would specify the following air quality when operating at the standard's reference conditions:

**Class 1 - Particulate**

In each cubic metre of compressed air, the particulate count should not exceed 20,000 particles in the 0.1 - 0.5 micron size range, 400 particles in the 0.5 - 1 micron size range and 10 particles in the 1 - 5 micron size range.

**Class 2 - Water**

A pressure dewpoint (PDP) of -40°C or better is required and no liquid water is allowed.

**Class 1 - Oil**

In each cubic metre of compressed air, not more than 0.01 mg of oil is allowed. This is a total level for liquid oil, oil aerosol and oil vapor.

**ISO8573-1:2010 Class zero**

- Class 0 does not mean zero contamination.
- Class 0 requires the user and the equipment manufacturer to agree contamination levels as part of a written specification.
- The agreed contamination levels for a Class 0 specification should be within the measurement capabilities of the test equipment and test methods shown in ISO8573 Pt 2 to Pt 9.
- The agreed Class 0 specification must be written on all documentation to be in accordance with the standard.
- Stating Class 0 without the agreed specification is meaningless and not in accordance with the standard.
- A number of compressor manufacturers claim that the delivered air from their oil-free compressors is in compliance with Class 0.
- If the compressor was tested in clean room conditions, the contamination detected at the outlet will be minimal. Should the same compressor now be installed in typical urban environment, the level of contamination will be dependent upon what is drawn into the compressor intake, rendering the Class 0 claim invalid.
- A compressor delivering air to Class 0 will still require purification equipment in both the compressor room and at the point of use for the Class 0 purity to be maintained at the application.
- Air for critical applications such as breathing, medical, food, etc typically only requires air quality to Class 2.2.1 or Class 2.1.1.
- Purification of air to meet a Class 0 specification is only cost effective if carried out at the point of use.

Stainless Steel

Stainless Steel with Brakes

High Torque Stainless Steel

Drilling, Milling & Grinding

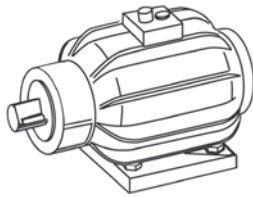
Air Motors



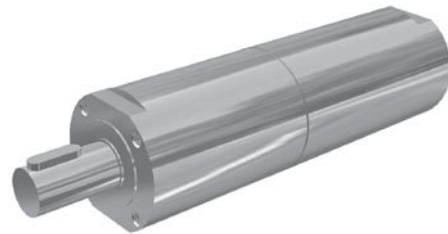
For inventory, lead time, and kit lookup, visit [www.pdnplu.com](http://www.pdnplu.com)

**P1V-S Series  
Stainless Steel Air Motors**

Stainless Steel  
Stainless Steel with Brakes  
High Torque Stainless Steel  
Drilling, Milling & Grinding  
Air Motors



Air motors have much smaller installation dimensions than corresponding electric motors.



The shape, design and non-lubricated operation allow the motor to be suitable for use in the food industry.



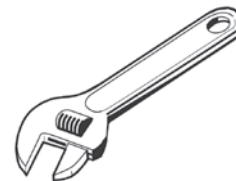
Air motors can be loaded until they stall, without damage. They are designed to be able to withstand the toughest heat, vibration, impact etc.



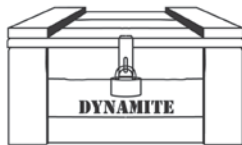
Air motors can be stopped and started continually without damage.



The weight of an air motor is several times less than corresponding electric motors.



The simple design principle of air motors makes them very easy to service.



Air motors can be used in the harshest environments. Most P1V-S motors are ATEX certified.



The motors are reversible as standard.



The choice of materials means that they can be used in damp and aggressive environments.

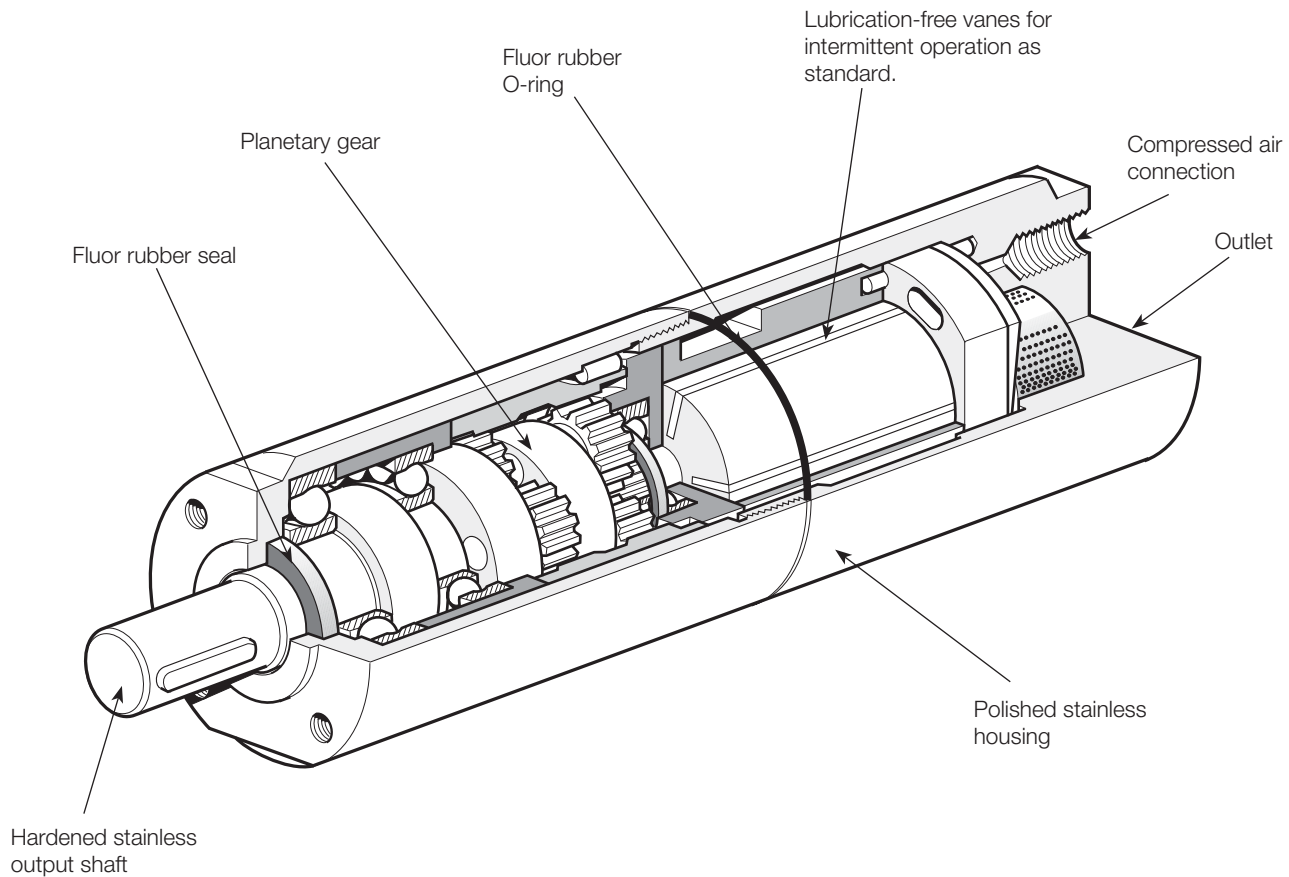


The reliability of air motors is very high, thanks to the design and the low number of moving parts.



For inventory, lead times, and kit lookup, visit [www.pdnplu.com](http://www.pdnplu.com)

**P1V-S stainless steel type - 0.02 to 1.2 kW**



**Stainless Steel Air Motors**

P1V-S is a range of air motors with all external components made of stainless steel, which means that they can be used in food grade applications, and in all other applications where there is a risk of corrosion.

The range contains seven different sizes, with powers ranging from 20 to 1,200 Watts, and speeds from 5 to 24,000 rpm. The air motor and planetary reduction gear are built into a polished stainless steel housing, which is sealed by a fluor rubber O-ring. The output shaft, which is made of polished stainless steel, is also sealed by a fluor rubber seal.

Consideration for achieving a clean, hygienic design was given early on in the development of this range of air motors. Thanks to the cylindrical shape, there are no pockets which can

accumulate dirt or bacteria. Additionally, the two halves of the motor body are sealed with an o-ring to prevent contamination. The choice of materials reflects the fact that aggressive cleaning materials are used in food grade applications.

The P1V-S series is designed to be operated in intermittent intervals under non-lubrication conditions. For this reason, no particles of lubricant escape with the exhaust air and the service costs are reduced. This means that the motors can be used directly in food grade applications. The planetary gear, which has one or more reduction stages, is lubricated with an USDA-H1 standard grease, approved for use in food grade applications.

Stainless Steel

Stainless Steel with Brakes

High Torque Stainless Steel

Drilling, Milling & Grinding

Air Motors



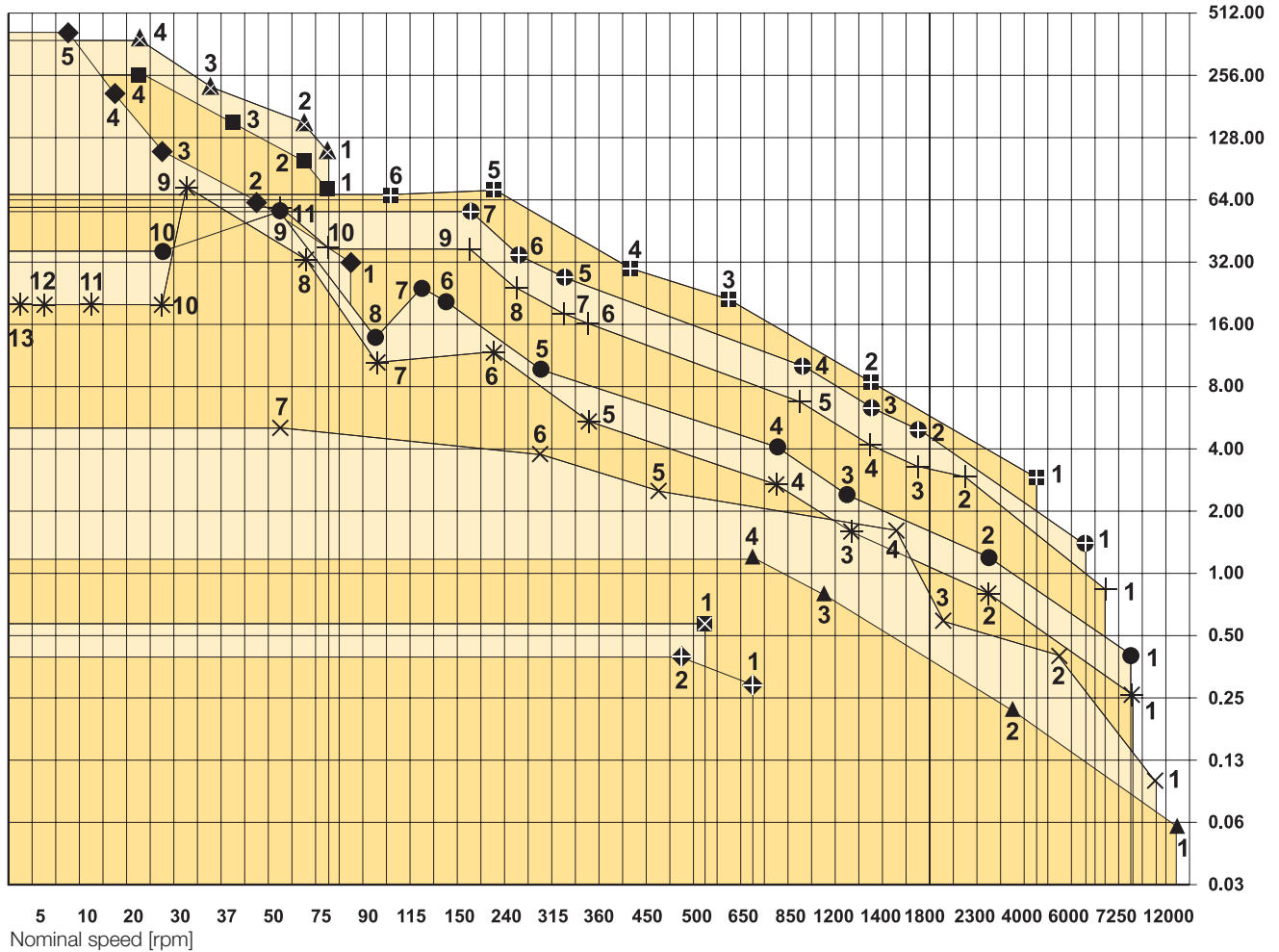
For inventory, lead time, and kit lookup, visit [www.pdnplu.com](http://www.pdnplu.com)

Features

Choice of an air motor

Stainless Steel  
Stainless Steel with Brakes  
High Torque Stainless Steel  
Drilling, Milling & Grinding  
Air Motors

Nominal torque [Nm]



**Legend**

- ⊕ P1V-S002
- ⊗ P1V-S003
- ▲ P1V-S008
- × P1V-S012
- \* P1V-S020
- P1V-S030
- + P1V-S060
- ⊕ P1V-S090
- ⊞ P1V-S120
- ◆ P1V-S028 HT
- P1V-S057 HT
- ▲ P1V-S086 HT

The motor to be used should be selected by starting with the torque needed at a specific shaft speed. In other words, to choose the right motor, you have to know the required speed and torque. Since maximum power is reached at half the motor's free speed, the motor should be chosen so that the operating point is as close as possible to the maximum power of the motor.

**Tip:** Select a motor which is slightly too fast and powerful, then regulate its speed and torque with a pressure regulator and/or throttle to achieve the optimum working point.

The design principle of the motor means that higher torque is generated when it is braked, which tends to increase the speed, etc. This means that the motor has a kind of speed self-regulation function built in.

Use the above graph to choose the correct motor size. The graph contains the points for the maximum torque of each motor at maximum output. Add your operating point to the graph, then select a marked point above and to the right of your point.








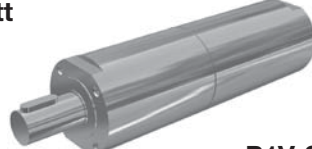
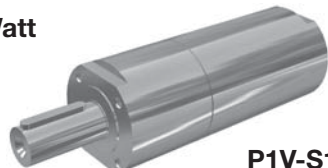
Then use the correct working diagram of the chosen motor to get more detailed technical data. Always select a motor whose requisite technical data are in the shaded area. Also use the correction diagram to find out what operation with different supply pressures would mean for the motor.



For inventory, lead times, and kit lookup, visit [www.pdnplu.com](http://www.pdnplu.com)

## Air Motors P1V-S Stainless Steel

### Overview

<ul style="list-style-type: none"> <li>✦ 1 P1V-S002A0130</li> <li>✦ 2 P1V-S002A0095</li> </ul>	<b>20 Watt</b>		<b>P1V-S002A</b>
<ul style="list-style-type: none"> <li>☒ 1 P1V-S003B0100</li> </ul>	<b>30 Watt</b>		<b>P1V-S003A</b>
<ul style="list-style-type: none"> <li>▲ 1 P1V-S008A0Q00</li> <li>▲ 2 P1V-S008A0700</li> <li>▲ 3 P1V-S008A0190</li> <li>▲ 4 P1V-S008A0130</li> </ul>	<b>80 Watt</b>		<b>P1V-S008A</b>
<ul style="list-style-type: none"> <li>✕ 1 P1V-S012A0N00, P1V-S012D0N00</li> <li>✕ 2 P1V-S012A0550, P1V-S012D0550</li> <li>✕ 3 P1V-S012A0360, P1V-S012D0360</li> <li>✕ 4 P1V-S012A0140, P1V-S012D0140</li> <li>✕ 5 P1V-S012A0090, P1V-S012D0090</li> <li>✕ 6 P1V-S012A0060, P1V-S012D0060</li> <li>✕ 7 P1V-S012A0010, P1V-S012D0010</li> </ul>	<b>120 Watt</b>		<b>P1V-S012</b>
<ul style="list-style-type: none"> <li>* 1 P1V-S020A0E50, P1V-S020D0E50</li> <li>* 2 P1V-S020A0460, P1V-S020D0460</li> <li>* 3 P1V-S020A0240, P1V-S020D0240</li> <li>* 4 P1V-S020A0140, P1V-S020D0140</li> <li>* 5 P1V-S020A0070, P1V-S020D0070</li> <li>* 6 P1V-S020A0032, P1V-S020D0032</li> <li>* 7 P1V-S020A0018, P1V-S020D0018</li> <li>* 10 P1V-S020A0005, P1V-S020D0005</li> <li>* 11 P1V-S020A0002</li> <li>* 12 P1V-S020A0001</li> <li>* 13 P1V-S020A00005</li> </ul>	<b>200 Watt</b>		<b>P1V-S020</b>
<ul style="list-style-type: none"> <li>● 1 P1V-S030A0E50, P1V-S030D0E50</li> <li>● 2 P1V-S030A0460, P1V-S030D0460</li> <li>● 3 P1V-S030A0240, P1V-S030D0240</li> <li>● 4 P1V-S030A0140, P1V-S030D0140</li> <li>● 5 P1V-S030A0060, P1V-S030D0060</li> <li>● 6 P1V-S030A0034, P1V-S030D0034</li> <li>● 7 P1V-S030A0023</li> <li>● 8 P1V-S030A0018, P1V-S030D0018</li> <li>● 9 P1V-S030A0010</li> <li>● 10 P1V-S030A0005, P1V-S030D0005</li> </ul>	<b>High torque</b> <b>300 Watt</b>		<b>P1V-S030</b>
<ul style="list-style-type: none"> <li>◆ 1 P1V-S028A0017</li> <li>◆ 2 P1V-S028A0008</li> <li>◆ 3 P1V-S028A0005</li> <li>◆ 4 P1V-S028A0003</li> <li>◆ 5 P1V-S028A0002</li> </ul>			
<ul style="list-style-type: none"> <li>+ 1 P1V-S060A0E00</li> <li>+ 2 P1V-S060A0350</li> <li>+ 3 P1V-S060A0270</li> <li>+ 4 P1V-S060A0170</li> <li>+ 5 P1V-S060A0063</li> <li>+ 6 P1V-S060A0048</li> <li>+ 7 P1V-S060A0030</li> <li>+ 8 P1V-S060A0015</li> </ul>	<b>600 Watt</b>		<b>P1V-S060A</b>
<ul style="list-style-type: none"> <li>■ 1 P1V-S057A0015</li> <li>■ 2 P1V-S057A0011</li> <li>■ 3 P1V-S057A0007</li> <li>■ 4 P1V-S057A0004</li> </ul>			
<ul style="list-style-type: none"> <li>⊕ 1 P1V-S090A0C00</li> <li>⊕ 2 P1V-S090A0350</li> <li>⊕ 3 P1V-S090A0270</li> <li>⊕ 4 P1V-S090A0170</li> <li>⊕ 5 P1V-S060A0063</li> <li>⊕ 6 P1V-S060A0048</li> <li>⊕ 7 P1V-S060A0030</li> </ul>	<b>900 Watt</b>		<b>P1V-S090A</b>
<ul style="list-style-type: none"> <li>▲ 1 P1V-S086A0015</li> <li>▲ 2 P1V-S086A0011</li> <li>▲ 3 P1V-S086A0007</li> <li>▲ 4 P1V-S086A0004</li> </ul>			
<ul style="list-style-type: none"> <li>■ 1 P1V-S120A0900</li> <li>■ 2 P1V-S120A0250</li> <li>■ 3 P1V-S120A0110</li> <li>■ 4 P1V-S120A0070</li> <li>■ 5 P1V-S120A0032</li> <li>■ 6 P1V-S120A0020</li> </ul>	<b>1200 Watt</b>		<b>P1V-S120A</b>

Stainless Steel

Stainless Steel  
with Brakes

High Torque  
Stainless Steel

Drilling, Milling &  
Grinding

Air Motors



For inventory, lead time, and kit lookup, visit [www.pdnplu.com](http://www.pdnplu.com)

J13

**Parker Hannifin Corporation**  
Pneumatic Division  
Richland, Michigan  
[www.parker.com/pneumatics](http://www.parker.com/pneumatics)

Technical Data

Stainless Steel	<b>Air motor size &amp; type</b>	<b>P1V-S002</b>	<b>P1V-S003</b>	<b>P1V-S008</b>	<b>P1V-S012</b>	<b>P1V-S020</b>	<b>P1V-S030</b>	<b>P1V-S060</b>	<b>P1V-S090</b>	<b>P1V-S120</b>	
	Nominal power (watts)	20	30	80	120	200	300	600	900	1200	
	Working pressure (bar)	3 to 7.6 in explosive atmosphere									
	Working temperature (°C)	-20 to +110									
Stainless Steel with Brakes	Ambient temperature (°C)	-20 to +40 in explosive atmosphere									
	Air flow required (NI/min)	100	100	230	300	370	470	850	1400	1600	
	Min pipe ID, inlet (mm)	3	3	4	6	10	10	12	12	19	
	Min pipe ID, outlet (mm)	3	3	4	6	10	10	12	12	19	

**Choice of treatment unit: recommended min air flow (l/min) at p1 7.5 bar and 0.8 bar pressure drop**

	120	120	260	340	410	510	900	1500	1800	
Medium	40 µm filtered, oil mist or dry unlubricated compressed air									
Oil free operation, indoor	ISO8573-1 purity class 3.4.1									
Oil free operation, outdoor	ISO8573-1 purity class 1.2.1									
Oil operation	1-2 drop per cube meter, ISO8573-1 purity class 3.-.5									
Recommended oil	Foodstuffs industry Klüber oil 4 UH1- 32 N									

**Choice of valve: recommended min nominal air flow (l/min) at p1 6 bar and 1 bar pressure drop**

	140	140	290	380	450	550	950	1600	2000
Sound level free outlet (dB(A))	98	98	95	99	100	103	103	106	108
With outlet silencer (dB(A))	85	85	85	92	82	91	94	88	95
Exhaust air removed with pipes to another room	74	74	71	70	71	70	76	80	87

**Note:** Sound levels are measured at free speed with the measuring instrument positioned 1 meter away from the air motor at an height of 1 meter.

**Table and diagram data**

All technical data are based on a working pressure of 6 bar and with oil. Oil-free performances are -10 to 15% lower. Data tolerance accuracy +-10%

**Material specification**

<b>Air motor size &amp; type</b>	<b>P1V-S002</b>	<b>P1V-S003</b>	<b>P1V-S008</b>	<b>P1V-S012</b>	<b>P1V-S020</b>	<b>P1V-S030</b>	<b>P1V-S060</b>	<b>P1V-S090</b>	<b>P1V-S120</b>	
Planetary gearbox housing	Stainless steel									
Planetary gearbox housing for last planet stage including installation flange	-	-	-	-	-	Black oxidized steel (not stainless)	-	-	-	
Air motor housing	Stainless steel									
Shaft	Hardened stainless steel									
Key	Hardened stainless steel									
External seal Fluor rubber	Fluor rubber FPM									
Internal steel parts	High grade steel (not stainless)									
Planetary gear grease used in	Grease, Shell Cassida RLS2									
Screws in housing in last planet stage	Surface treated steel (not stainless)									
<b>Accessories</b>	<b>P1V</b>									
Flange bracket	Stainless steel									
Foot bracket	Stainless steel									
Screws for the mountings	Stainless steel DIN A2									



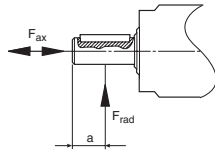
For inventory, lead times, and kit lookup, visit [www.pdnplu.com](http://www.pdnplu.com)



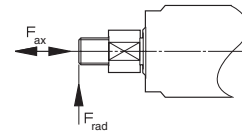
**Permitted shaft loadings**

Max. permitted load on output shaft for motors (based on 10,000,000 rpm at input shaft with 90% probable service life for ball bearings).

**Figure 1:**  
 Load on output shaft for basic motor with keyed shaft.



**Figure 2:**  
 Load on output shaft for basic motor with threaded shaft.



**Motor with keyed shaft**

Part number	Fax [N]	Frad [N]	a [mm]
P1V-S002A0130	140	180	6
P1V-S002A0095	140	180	6
P1V-S003B0100	140	180	6
P1V-S008A0Q00	200	220	7
P1V-S008A0700	200	220	7
P1V-S008A0190	200	220	7
P1V-S008A0130	200	220	7
P1V-S012AN00	380	160	9
P1V-S012A550	380	160	9
P1V-S012A360	380	160	9
P1V-S012A140	380	160	9
P1V-S012A090	380	160	9
P1V-S012A060	380	160	9
P1V-S012A010	380	160	9
P1V-S020A0E50	570	720	12
P1V-S020A0460	570	720	12
P1V-S020A0240	570	720	12
P1V-S020A0140	570	720	12
P1V-S020A0070	570	720	12
P1V-S020A0032	570	720	12
P1V-S020A0018	570	720	12
P1V-S020A0005	570	720	12
P1V-S020A0002	570	720	12
P1V-S020A0001	570	720	12
P1V-S020A00005	570	720	12
P1V-S030A0E50	570	1130	14
P1V-S030A0460	570	1130	14
P1V-S030A0240	570	1130	14
P1V-S030A0140	570	1130	14
P1V-S030A0060	790	1070	15
P1V-S030A0034	790	1070	15
P1V-S030A0023	790	1070	15
P1V-S030A0018	790	1070	15
P1V-S030A0010	790	1070	15
P1V-S030A0005	790	1070	15
P1V-S060A0E00	1110	1300	15
P1V-S060A0350	1110	1300	15
P1V-S060A0270	1110	1300	15
P1V-S060A0170	1110	1300	15
P1V-S060A0063	1110	1300	15
P1V-S060A0048	1130	2090	18
P1V-S060A0030	1130	2090	18
P1V-S060A0015	1130	2090	18
P1V-S090A0C00	1110	1300	15
P1V-S090A0350	1110	1300	15
P1V-S090A0270	1110	1300	15
P1V-S090A0170	1110	1300	15
P1V-S090A0063	1110	1300	15
P1V-S090A0048	1130	2090	18
P1V-S090A0030	1130	2090	18
P1V-S120A0900	2330	2260	18
P1V-S120A0250	2330	2260	18
P1V-S120A0110	2330	2260	18
P1V-S120A0070	2330	2700	30
P1V-S120A0032	2330	2700	30
P1V-S120A0020	2330	2700	30
P1V-S028A0017	1500	3500	21
P1V-S028A0008	1500	3500	21
P1V-S028A0005	1500	3500	21
P1V-S028A0003	1500	3500	20
P1V-S028A0002	1500	3500	20
P1V-S057A0015	1500	3500	21
P1V-S057A0011	1500	3500	21
P1V-S057A0007	1500	3500	21
P1V-S057A0004	1500	3500	22.5
P1V-S086A0015	1500	3500	21
P1V-S086A0011	1500	3500	21
P1V-S086A0007	1500	3500	21
P1V-S086A0004	1500	3500	22.5

**Motor with threaded shaft**

Part number	Fax [N]	Frad [N]	a [mm]
P1V-S012DN00	380	110	0
P1V-S012D550	380	110	0
P1V-S012D360	380	110	0
P1V-S012D140	380	110	0
P1V-S012D090	380	110	0
P1V-S012D060	380	110	0
P1V-S012D010	380	110	0
P1V-S020D0E50	570	450	0
P1V-S020D0460	570	450	0
P1V-S020D0240	570	450	0
P1V-S020D0140	570	450	0
P1V-S020D0070	570	450	0
P1V-S020D0032	570	450	0
P1V-S020D0018	570	450	0
P1V-S020D0005	570	450	0
P1V-S030D0E50	570	860	0
P1V-S030D0460	570	860	0
P1V-S030D0240	570	860	0
P1V-S030D0140	570	860	0
P1V-S030D0060	790	820	0
P1V-S030D0034	790	820	0
P1V-S030D0018	790	820	0
P1V-S030D0005	790	820	0

Frad = Radial loading (N)  
 Fax = Axial loading (N)  
 a = distance from shaft's end (mm)



For inventory, lead time, and kit lookup, visit [www.pdnplu.com](http://www.pdnplu.com)

Stainless Steel

Stainless Steel  
with Brakes

High Torque  
Stainless Steel

Drilling, Milling &  
Grinding

Air Motors

Order Key Information

**Order key** (This model code can not be used for creating new part numbers except for optional function. All possible combinations between motor size, function and free speed are in the next pages).

<b>P1V-S</b>	<b>020</b>	<b>A</b>	<b>A</b>	<b>E50</b>																																																																										
<table border="1"> <tr><th colspan="2">Air motor range</th></tr> <tr><td>P1V-S</td><td>Stainless steel motor</td></tr> </table>	Air motor range		P1V-S	Stainless steel motor	<table border="1"> <tr><th colspan="2">Motor size</th></tr> <tr><td>002</td><td>20 W</td></tr> <tr><td>003</td><td>30 W</td></tr> <tr><td>008</td><td>80 W</td></tr> <tr><td>012</td><td>120 W</td></tr> <tr><td>020</td><td>200 W</td></tr> <tr><td>028</td><td>285 W High torque</td></tr> <tr><td>030</td><td>300 W</td></tr> <tr><td>057</td><td>570 W High torque</td></tr> <tr><td>060</td><td>600 W</td></tr> <tr><td>086</td><td>860 W High torque</td></tr> <tr><td>090</td><td>900 W</td></tr> <tr><td>120</td><td>1200 W</td></tr> </table>	Motor size		002	20 W	003	30 W	008	80 W	012	120 W	020	200 W	028	285 W High torque	030	300 W	057	570 W High torque	060	600 W	086	860 W High torque	090	900 W	120	1200 W	<table border="1"> <tr><th colspan="2">Function</th></tr> <tr><td>A</td><td>Keyed or flattened shaft</td></tr> <tr><td>B</td><td>Keyed or flattened shaft right rotation</td></tr> <tr><td>D</td><td>Threaded shaft</td></tr> </table>	Function		A	Keyed or flattened shaft	B	Keyed or flattened shaft right rotation	D	Threaded shaft	<table border="1"> <tr><th colspan="2">Optional function</th></tr> <tr><td>O</td><td>Standard vanes</td></tr> <tr><td>C</td><td>Continuous lubrication-free operation</td></tr> <tr><td>Z*</td><td>Standard spring loaded vanes</td></tr> <tr><td>M*</td><td>Continuous. spring loaded vanes</td></tr> <tr><td>D**</td><td>Standard with brake</td></tr> <tr><td>E**</td><td>Option C with brake</td></tr> <tr><td>F**</td><td>Option Z with brake</td></tr> <tr><td>G**</td><td>Option M with brake</td></tr> </table>	Optional function		O	Standard vanes	C	Continuous lubrication-free operation	Z*	Standard spring loaded vanes	M*	Continuous. spring loaded vanes	D**	Standard with brake	E**	Option C with brake	F**	Option Z with brake	G**	Option M with brake	<table border="1"> <tr><th colspan="2">Free speed per min</th></tr> <tr><td>0005</td><td>5</td></tr> <tr><td>001</td><td>10</td></tr> <tr><td>999</td><td>9990</td></tr> <tr><td>A00</td><td>10000</td></tr> <tr><td>E00</td><td>14000</td></tr> <tr><td>E50</td><td>14500</td></tr> <tr><td>N00</td><td>22000</td></tr> <tr><td>Q00</td><td>24000</td></tr> </table>	Free speed per min		0005	5	001	10	999	9990	A00	10000	E00	14000	E50	14500	N00	22000	Q00	24000
Air motor range																																																																														
P1V-S	Stainless steel motor																																																																													
Motor size																																																																														
002	20 W																																																																													
003	30 W																																																																													
008	80 W																																																																													
012	120 W																																																																													
020	200 W																																																																													
028	285 W High torque																																																																													
030	300 W																																																																													
057	570 W High torque																																																																													
060	600 W																																																																													
086	860 W High torque																																																																													
090	900 W																																																																													
120	1200 W																																																																													
Function																																																																														
A	Keyed or flattened shaft																																																																													
B	Keyed or flattened shaft right rotation																																																																													
D	Threaded shaft																																																																													
Optional function																																																																														
O	Standard vanes																																																																													
C	Continuous lubrication-free operation																																																																													
Z*	Standard spring loaded vanes																																																																													
M*	Continuous. spring loaded vanes																																																																													
D**	Standard with brake																																																																													
E**	Option C with brake																																																																													
F**	Option Z with brake																																																																													
G**	Option M with brake																																																																													
Free speed per min																																																																														
0005	5																																																																													
001	10																																																																													
999	9990																																																																													
A00	10000																																																																													
E00	14000																																																																													
E50	14500																																																																													
N00	22000																																																																													
Q00	24000																																																																													

\* Not for P1V-S002, P1V-S003 and P1V-S008  
\*\* Only for P1V-S020, P1V-S030 and P1V-S120

Choice of vanes

**O = Standard vanes**

These motors are of the vane type for intermittent lubrication-free operation.

They can operate 70% of the time for up to 15 minutes without lubrication.

With lubrication, these motors can operation 100% of the time.

**C = Vanes for continuous lubrication-free operation**

This motor is equipped with vanes for continuous lubrication-free operation.

(To obtain the longest possible service life, we recommend no oil in the air.)

**Z = Standard spring loaded vanes**

All vanes are spring loaded to ensure that they remain

pressed against the cylinder when the motor stops. The spring loaded vane option also prevents the vanes from sliding down in their track if vibration is introduced.

The spring loaded vanes therefore provide a higher starting torque, improved starting and low speed characteristics, because the leakage over the vanes is reduced to a minimum.

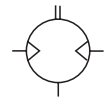
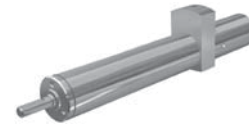
**M = Spring loaded vanes for continuous lubrication-free operation**

Multi (combination of Z + C) see previous columns



For inventory, lead times, and kit lookup, visit [www.pdnplu.com](http://www.pdnplu.com)

**NOTE!** All technical data are based on a working pressure of 6 bar and with oil. For oil-free performances are -10 to 15% lower. Data tolerance accuracy +-10%



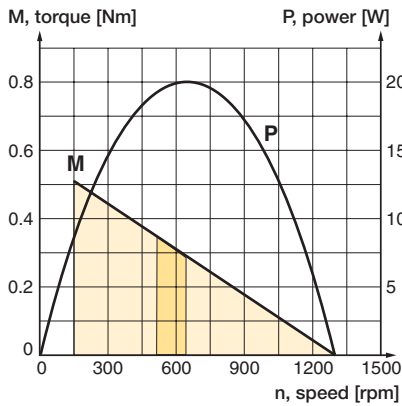
**Reversible air motor with flattened shaft, P1V-S002A series**

Max power kW	Free speed* rpm	Nominal speed rpm	Nominal torque Nm	Min start torque Nm	Air consumption at max power l/s	Conn.	Min pipe ID mm	Weight Kg	Part number
0.02	1,300	650	0.29	0.44	1.7	M5	3	0.16	<b>P1V-S002A0130</b>
0.02	950	475	0.40	0.60	1.7	M5	3	0.60	<b>P1V-S002A0095</b>

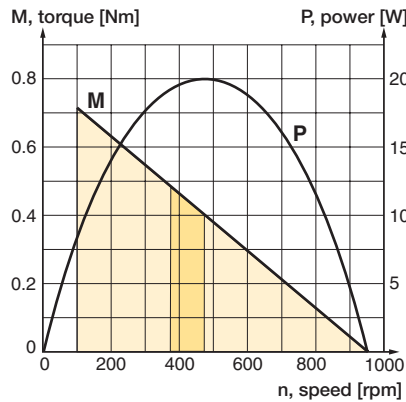
**NOTE!** Not available with vane options C, Z or M.  
The P1V-S002A requires oil mist for lubricating the gearbox.

\* maximum admissible speed (idling)

**P1V-S002A0130**

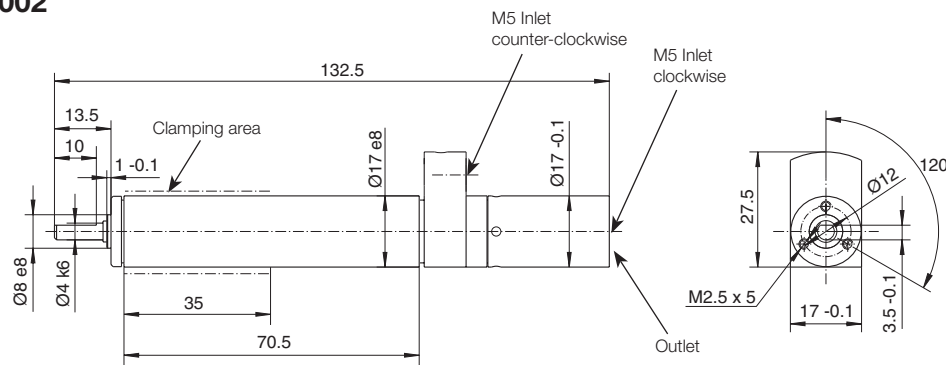


**P1V-S002A0095**



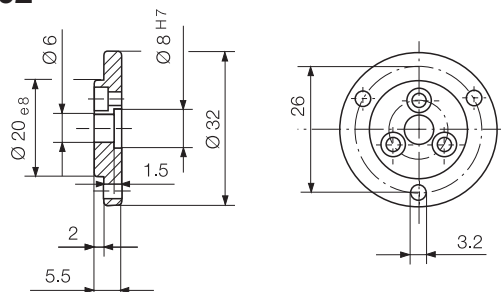
Possible working range of motor.  
 Optimum working range of motor.  
Higher speeds = more vane wear  
Lower speeds with high torque = more gearbox wear

**Motor P1V-S002**



**Flange for P1V-S002**

**P1V-S4002B**



For inventory, lead time, and kit lookup, visit [www.pdnplu.com](http://www.pdnplu.com)

Stainless Steel

Stainless Steel with Brakes

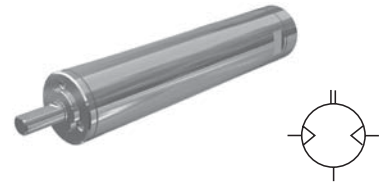
High Torque Stainless Steel

Drilling, Milling & Grinding

Air Motors

Specifications – 30 Watts

**NOTE!** All technical data are based on a working pressure of 6 bar and with oil. For oil-free performances are -10 to 15% lower. Data tolerance accuracy +-10%



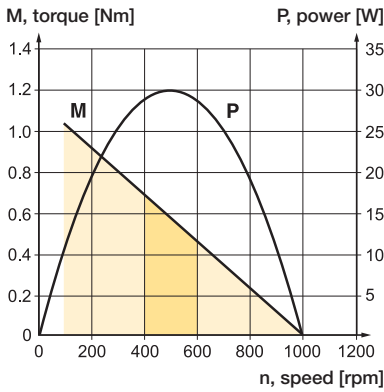
Right rotation air motor with flattened shaft, P1V-S003A series

Max power kW	Free speed* rpm	Nominal speed rpm	Nominal torque Nm	Min start torque Nm	Air consumption at max power l/s	Conn.	Min pipe ID mm	Weight Kg	Part number
0.30	1,000	500	0.57	0.85	1.7	M8x0.75	3	0.13	<b>P1V-S003B0100</b>

**NOTE!** Not available with vane options C, Z or M.  
The P1V-S003A requires oil mist for lubricating the gearbox.

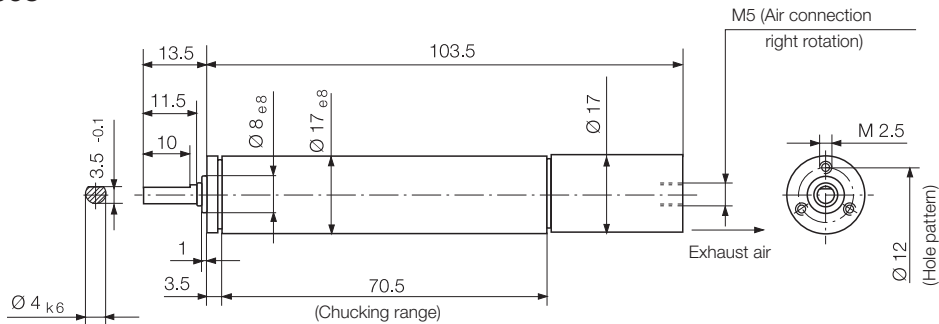
\* maximum admissible speed (idling)

**P1V-S003B0100**



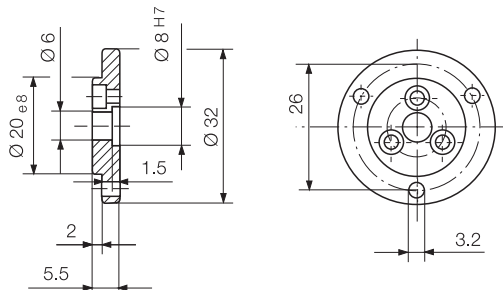
**Possible working range of motor.**  
**Optimum working range of motor.**  
Higher speeds = more vane wear  
Lower speeds with high torque = more gearbox wear

**Motor P1V-S003**



**Flange for P1V-S003**

P1V-S4002B



For inventory, lead times, and kit lookup, visit [www.pdnplu.com](http://www.pdnplu.com)

**NOTE!** All technical data are based on a working pressure of 6 bar and with oil. For oil-free performances are -10 to 15% lower. Data tolerance accuracy +-10%

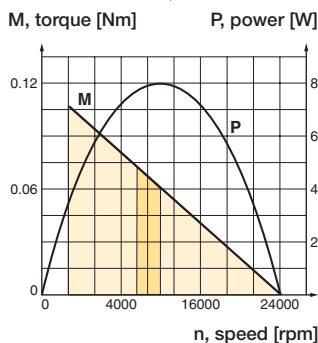


**Reversible air motor with flattened shaft, P1V-S008A series**

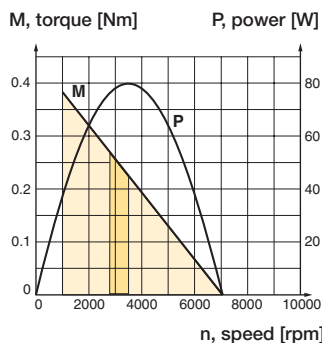
Max power kW	Free speed* rpm	Nominal speed rpm	Nominal torque Nm	Min start torque Nm	Air consumption at max power l/s	Conn.**	Min pipe ID mm	Weight Kg	Part number
0.08	22,000	1,100	0.06	0.09	3.8	M8x0.75	4	0.20	<b>P1V-S008A0Q00</b>
0.08	7,000	3,500	0.22	0.30	3.8	M8x0.75	4	0.20	<b>P1V-S008A0700</b>
0.08	1,900	950	0.80	1.20	3.8	M8x0.75	4	0.22	<b>P1V-S008A0190</b>
0.08	1,300	650	1.20	1.80	3.8	M8x0.75	4	0.22	<b>P1V-S008A0130</b>

**NOTE!** Not available with vane options C, Z or M.  
The P1V-S008A requires oil mist for lubricating the gearbox.  
\* maximum admissible speed (idling)  
\*\* 3 push in nipples for plastic pipe Ø6/4 supplied

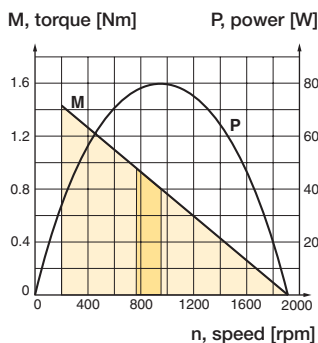
**P1V-S008A0Q00**



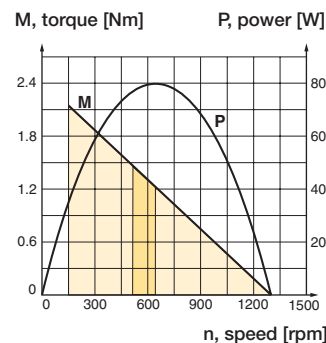
**P1V-S008A0700**



**P1V-S008A0190**



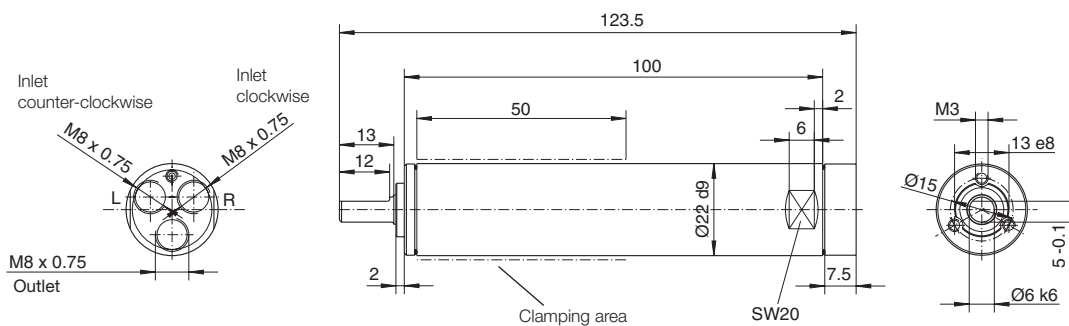
**P1V-S008A0130**



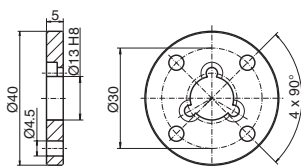
Possible working range of motor.

Optimum working range of motor.  
Higher speeds = more vane wear  
Lower speeds with high torque = more gearbox wear

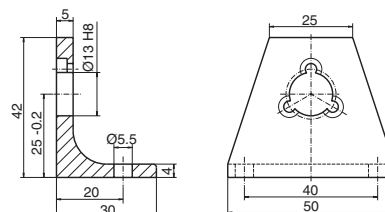
**Motor P1V-S008**



**Flange  
P1V-S4008B**



**Foot bracket  
P1V-S4008F**



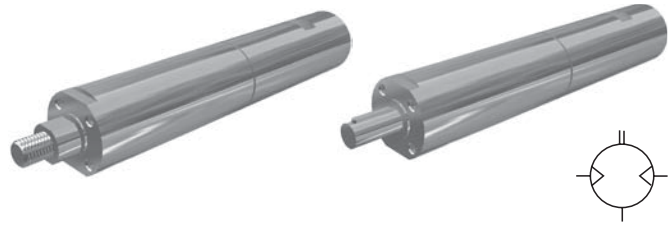
For inventory, lead time, and kit lookup, visit [www.pdnplu.com](http://www.pdnplu.com)

Stainless Steel  
Stainless Steel with Brakes  
High Torque Stainless Steel  
Drilling, Milling & Grinding  
Air Motors

**Specifications – 120 Watts**

**Air Motors  
P1V-S Stainless Steel**

**NOTE!** All technical data are based on a working pressure of 6 bar and with oil. For oil-free performances are -10 to 15% lower. Data tolerance accuracy +-10%



CE Ex II2 GD c IIC T6 (80°C) X

**Reversible air motor, P1V-S012A series**

Max power kW	Free speed* rpm	Nominal speed rpm	Nominal torque Nm	Min start torque Nm	Air consumption at max power l/s	Conn.	Min pipe ID mm	Weight Kg	Part number
0.12	22,000	11,000	0.10	0.15	5.0	G1/8	6	0.35	<b>P1V-S012•0N00</b>
0.12	5,500	2,750	0.40	0.60	5.0	G1/8	6	0.35	<b>P1V-S012•0550</b>
0.12	3,600	1,800	0.60	0.90	5.0	G1/8	6	0.35	<b>P1V-S012•0360</b>
0.12	1,400	700	1.60	2.40	5.0	G1/8	6	0.40	<b>P1V-S012•0140</b>
0.12	900	450	2.50	3.80	5.0	G1/8	6	0.40	<b>P1V-S012•0090</b>
0.12	600	300	3.80	5.00**	5.0	G1/8	6	0.40	<b>P1V-S012•0060</b>
0.09	100	50	5.00**	5.00**	5.0	G1/8	6	0.45	<b>P1V-S012•0010</b>

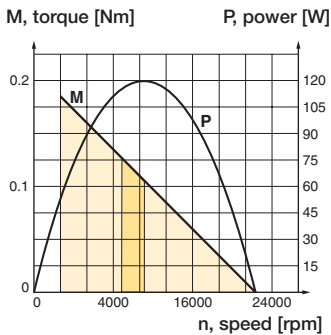
\* maximum admissible speed (idling)

\*\* Max permitted torque for the gearbox

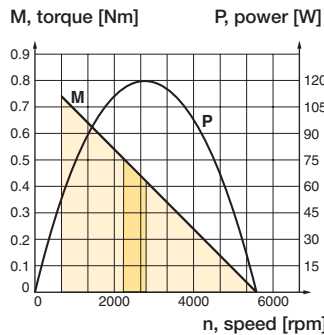
The P1V-S012D with threaded shaft may be reversed, but when operated counter-clockwise, there is a risk that the driven unit may disconnect if it is not locked properly.

• A letter for keyed shaft, D for threaded end shaft

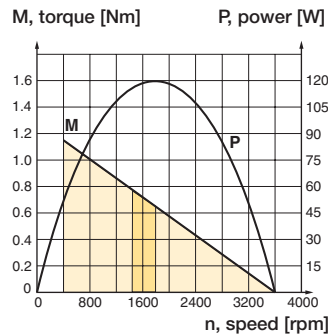
**P1V-S012•0N00**



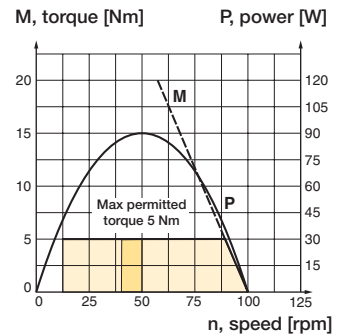
**P1V-S012•0550**



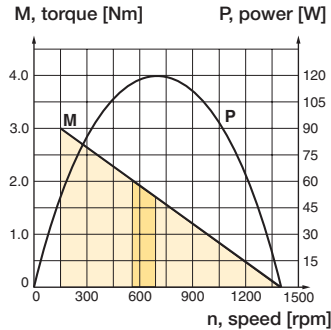
**P1V-S012•0360**



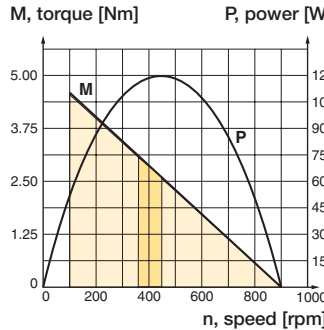
**P1V-S012•0010**



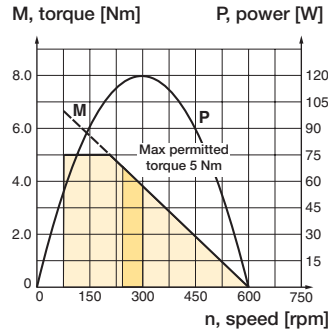
**P1V-S012•0140**



**P1V-S012•0090**



**P1V-S012•0060**



Possible working range of motor.

Optimum working range of motor.

Higher speeds = more vane wear

Lower speeds with high torque = more gearbox wear

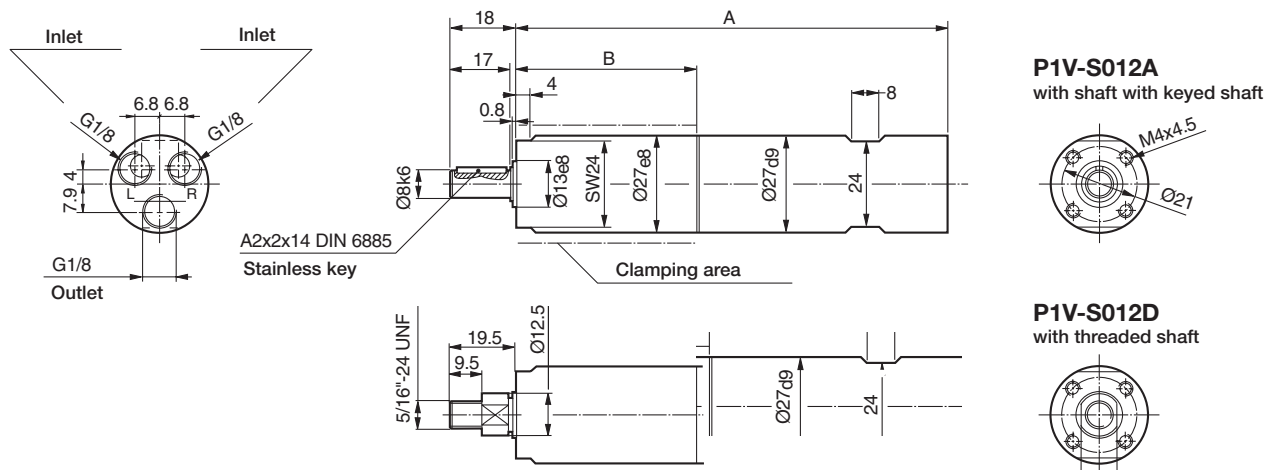


For inventory, lead times, and kit lookup, visit [www.pdnplu.com](http://www.pdnplu.com)

J20

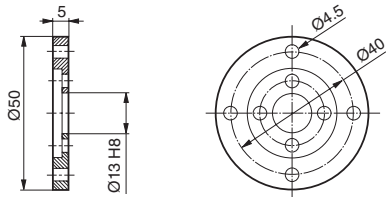
**Parker Hannifin Corporation**  
Pneumatic Division  
Richland, Michigan  
[www.parker.com/pneumatics](http://www.parker.com/pneumatics)

**Motor P1V-S012**

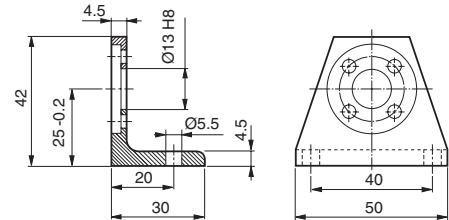


	A	B
P1V-S012A0N00, P1V-S012D0N00	117.0	46.5
P1V-S012A0550, P1V-S012D0550	117.0	46.5
P1V-S012A0360, P1V-S012D0360	117.0	46.5
P1V-S012A0140, P1V-S012D0140	129.5	59.0
P1V-S012A0090, P1V-S012D0090	129.5	59.0
P1V-S012A0060, P1V-S012D0060	129.5	59.0
P1V-S012A0010, P1V-S012D0010	142.0	71.5

**Flange**  
**P1V-S4012B**



**Foot bracket**  
**P1V-S4012F**



Stainless Steel

Stainless Steel  
with Brakes

High Torque  
Stainless Steel

Drilling, Milling &  
Grinding

Air Motors



For inventory, lead time, and kit lookup, visit [www.pdnplu.com](http://www.pdnplu.com)

J21

**Parker Hannifin Corporation**  
 Pneumatic Division  
 Richland, Michigan  
[www.parker.com/pneumatics](http://www.parker.com/pneumatics)

**NOTE!** All technical data are based on a working pressure of 6 bar and with oil. For oil-free performances are -10 to 15% lower. Data tolerance accuracy +-10%



CE IIC GD c IIC T6 (80°C) X

Reversible air motor with keyed shaft, P1V-S020A series

Max power kW	Free speed* rpm	Nominal speed rpm	Nominal torque Nm	Min start torque Nm	Air consumption at max power l/s	Conn.	Min pipe ID mm	Weight Kg	Part number
0.20	14,500	7,250	0.26	0.40	6.2	G1/8	10	0.70	<b>P1V-S020•0E50</b>
0.20	4,600	2,300	0.80	1.20	6.2	G1/8	10	0.75	<b>P1V-S020•0460</b>
0.20	2,400	1,200	1.60	2.40	6.2	G1/8	10	0.75	<b>P1V-S020•0240</b>
0.20	1,400	700	2.70	4.10	6.2	G1/8	10	0.85	<b>P1V-S020•0140</b>
0.20	700	350	5.40	8.20	6.2	G1/8	10	0.85	<b>P1V-S020•0070</b>
0.20	320	160	12.00	18.00	6.2	G1/8	10	0.85	<b>P1V-S020•0032</b>
0.10	180	90	10.50	1.00	4.5	G1/8	10	0.85	<b>P1V-S020•0018</b>
0.18	50	25	20**	20**	6.2	G1/8	10	0.95	<b>P1V-S020•0005</b>
0.18	20	-	20**	20**	6.2	G1/8	10	0.95	<b>P1V-S020A0002</b>
0.18	10	-	20**	20**	6.2	G1/8	10	1.05	<b>P1V-S020A0001</b>
0.18	5	-	20**	20**	6.2	G1/8	10	1.05	<b>P1V-S020A00005</b>

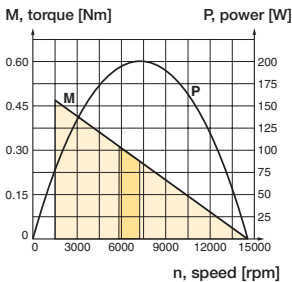
\* maximum admissible speed (idling)

\*\* Max permitted torque for the gearbox

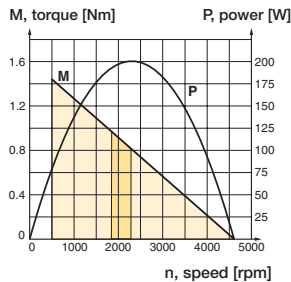
The P1V-S020D with threaded shaft may be reversed, but when operated counter-clockwise, there is a risk that the driven unit may disconnect if it is not locked properly.

• A letter for keyed shaft, D for threaded end shaft

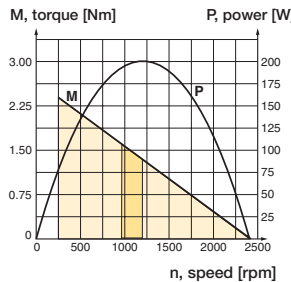
**P1V-S020•0E50**



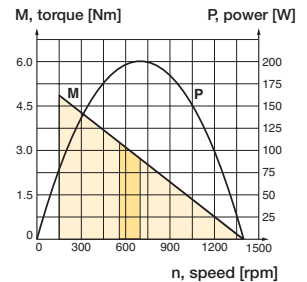
**P1V-S020•0460**



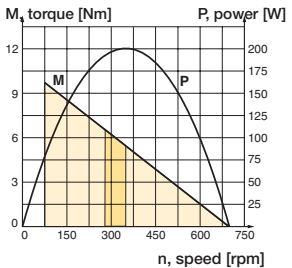
**P1V-S020•0240**



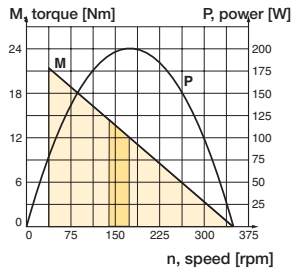
**P1V-S020•0140**



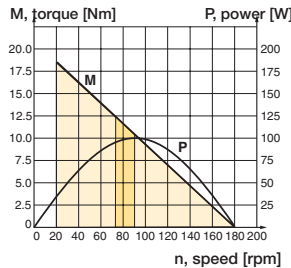
**P1V-S020•0070**



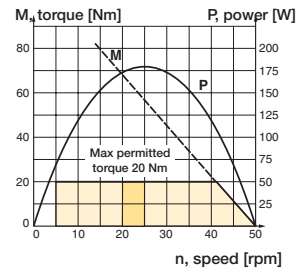
**P1V-S020•0032**



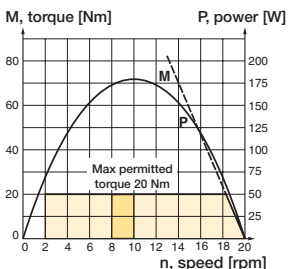
**P1V-S020•0018**



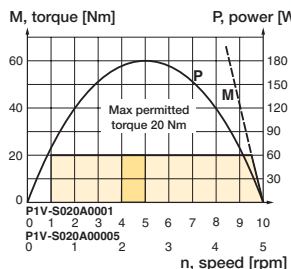
**P1V-S020•0005**



**P1V-S020A0002**



**P1V-S020A0001 & P1V-S020A00005**



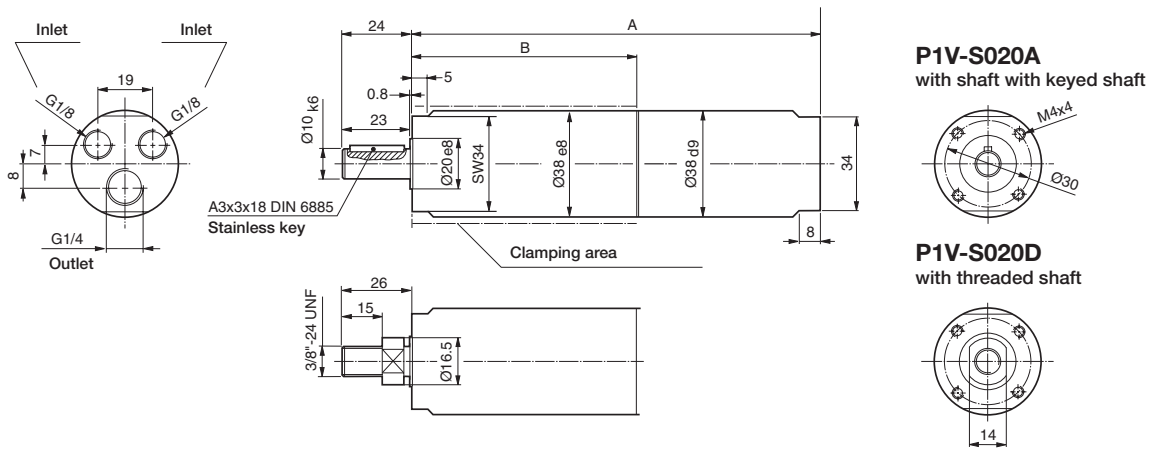
Possible working range of motor.  
 Optimum working range of motor.  
 Higher speeds = more vane wear  
 Lower speeds with high torque = more gearbox wear



For inventory, lead times, and kit lookup, visit [www.pdnplu.com](http://www.pdnplu.com)

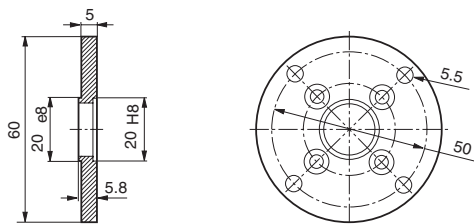


**Motor P1V-S020**

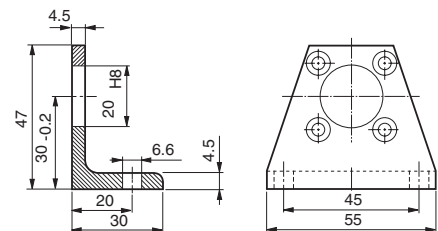


		A	B
P1V-S020A0E50,	P1V-S020D0E50	127	63.5
P1V-S020A0460,	P1V-S020D0460	127	63.5
P1V-S020A0240,	P1V-S020D0240	127	63.5
P1V-S020A0140,	P1V-S020D0140	143	79.5
P1V-S020A0070,	P1V-S020D0070	143	79.5
P1V-S020A0032,	P1V-S020D0032	143	79.5
P1V-S020A0018,	P1V-S020D0018	143	79.5
P1V-S020A0005,	P1V-S020D0005	159	95.5
P1V-S020A0002		159	95.5
P1V-S020A0001		175	111.5
P1V-S020A00005		175	111.5

**Flange**  
**P1V-S4020B**



**Foot bracket**  
**P1V-S4020F**



Stainless Steel

Stainless Steel  
with Brakes

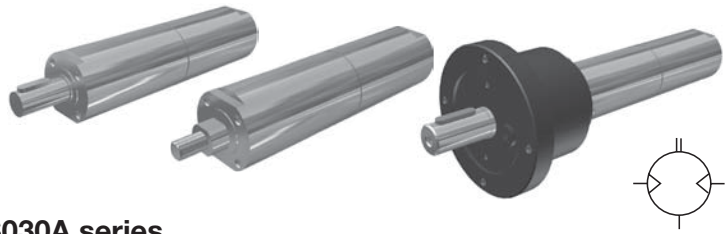
High Torque  
Stainless Steel

Drilling, Milling &  
Grinding

Air Motors



**NOTE!** All technical data are based on a working pressure of 6 bar and with oil. For oil-free performances are -10 to 15% lower. Data tolerance accuracy +/-10%



CE Ex II2 GD c IIC T6 (80°C) X

**Reversible air motor with keyed shaft, P1V-S030A series**

Max power kW	Free speed* rpm	Nominal speed rpm	Nominal torque Nm	Min start torque Nm	Air consumption at max power l/s	Conn.	Min pipe ID mm	Weight Kg	Part number
0.30	14,500	7,250	0.40	0.60	7.8	G1/4	10	1.00	<b>P1V-S030•0E50</b>
0.30	4,600	2,300	1.20	1.90	7.8	G1/4	10	1.05	<b>P1V-S030•0460</b>
0.30	2,400	1,200	2.40	3.60	7.8	G1/4	10	1.05	<b>P1V-S030•0240</b>
0.30	1,400	700	4.10	6.10	7.8	G1/4	10	1.10	<b>P1V-S030•0140</b>
0.30	600	300	9.60	14.30	7.8	G1/4	10	1.15	<b>P1V-S030•0060</b>
0.30	340	170	16.90	25.30	7.8	G1/4	10	1.15	<b>P1V-S030•0034</b>
0.30	230	115	24.00	36.00	7.8	G1/4	10	3.30	<b>P1V-S030A0023</b>
0.13	180	90	13.80	21.00	4.7	G1/4	10	1.15	<b>P1V-S030•0018</b>
0.30	100	50	57.00	85.50	7.8	G1/4	10	3.30	<b>P1V-S030A0010</b>
0.28	50	25	36**	36**	7.8	G1/4	10	1.25	<b>P1V-S030•0005</b>

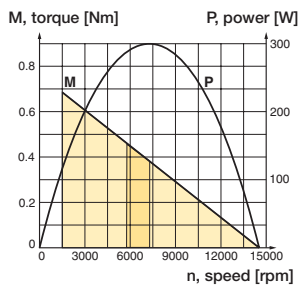
\* maximum admissible speed (idling)

\*\* Max permitted torque for the gearbox

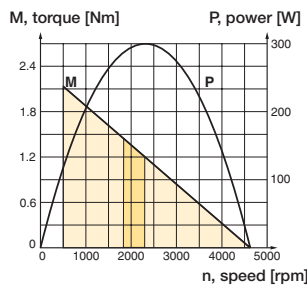
The P1V-S030D with threaded shaft may be reversed, but when operated counter-clockwise, there is a risk that the driven unit may disconnect if it is not locked properly.

• A letter for keyed shaft, D for threaded end shaft

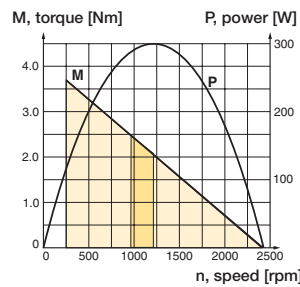
**P1V-S030•0E50**



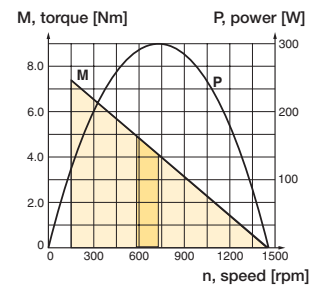
**P1V-S030•0460**



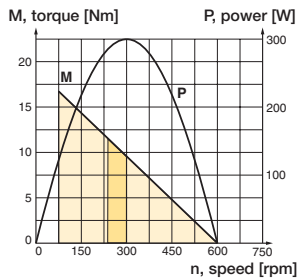
**P1V-S030•0240**



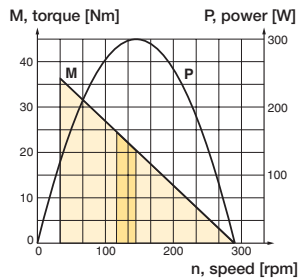
**P1V-S030•0140**



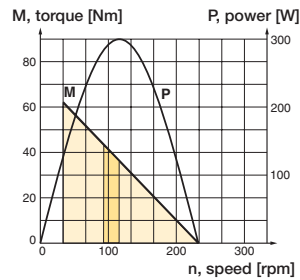
**P1V-S030•0060**



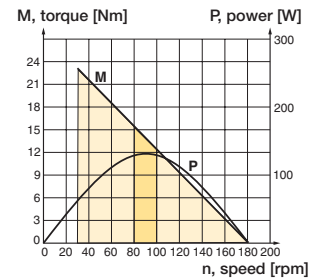
**P1V-S030•0034**



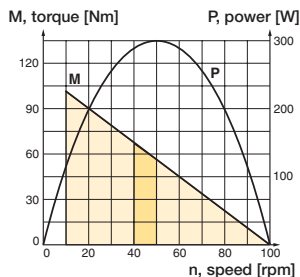
**P1V-S030A0023**



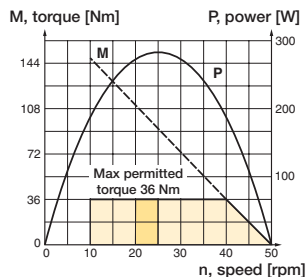
**P1V-S030•0018**



**P1V-S030A0010**



**P1V-S030•0005**

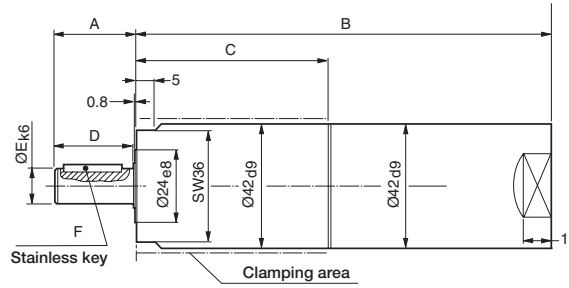
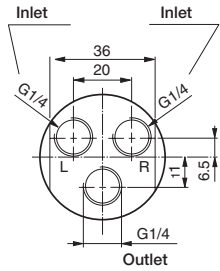


Possible working range of motor.  
 Optimum working range of motor.  
 Higher speeds = more vane wear  
 Lower speeds with high torque = more gearbox wear

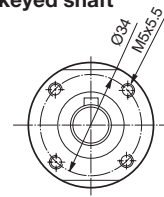


For inventory, lead times, and kit lookup, visit [www.pdnplu.com](http://www.pdnplu.com)

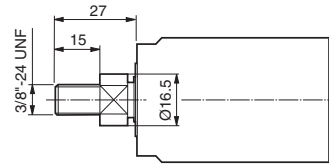
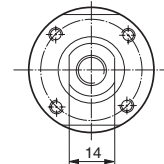
Motor P1V-S030



P1V-S030A with shaft with keyed shaft

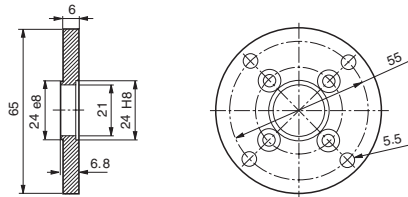


P1V-S030D with threaded shaft

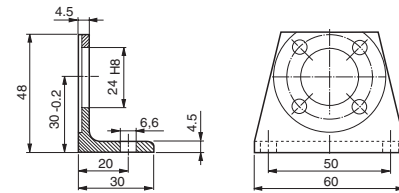


	A	B	C	D	E	F
P1V-S030A0E50, P1V-S030D0E50	28.5	143	66	27	12	A4x4x20 DIN 6885
P1V-S030A0460, P1V-S030D0460	28.5	143	66	27	12	A4x4x20 DIN 6885
P1V-S030A0240, P1V-S030D0240	28.5	143	66	27	12	A4x4x20 DIN 6885
P1V-S030A0140, P1V-S030D0140	28.5	159	82	27	12	A4x4x20 DIN 6885
P1V-S030A0060, P1V-S030D0060	32.0	159	82	30	14	A5x5x20 DIN 6885
P1V-S030A0034, P1V-S030D0034	32.0	159	82	30	14	A5x5x20 DIN 6885
P1V-S030A0018, P1V-S030D0018	32.0	159	82	30	14	A5x5x20 DIN 6885
P1V-S030A0005, P1V-S030D0005	32.0	164	82	30	14	A5x5x20 DIN 6885

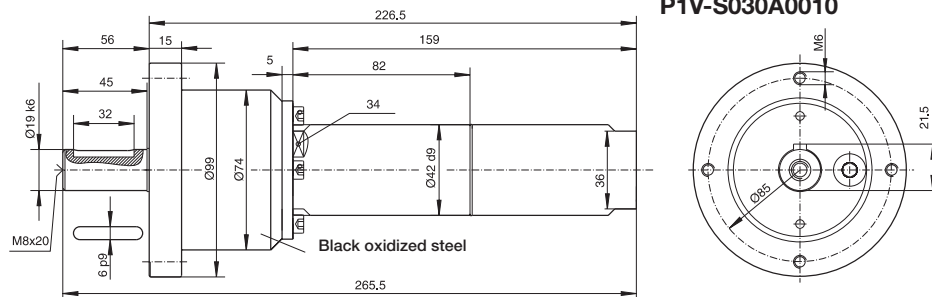
Flange  
P1V-S4030B



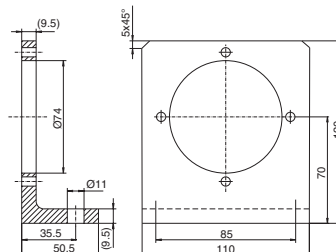
Foot bracket  
P1V-S4030F



P1V-S030A0023  
P1V-S030A0010



Foot bracket for motors  
P1V-S030A0023 and P1V-S030A0010  
P1V-S4020C



For inventory, lead time, and kit lookup, visit [www.pdnplu.com](http://www.pdnplu.com)

Stainless Steel

Stainless Steel with Brakes

High Torque Stainless Steel

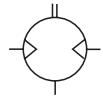
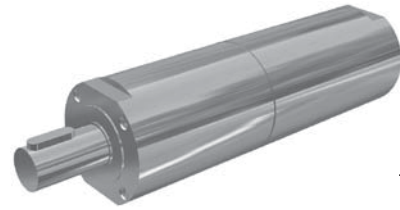
Drilling, Milling & Grinding

Air Motors



**NOTE!** All technical data are based on a working pressure of 6 bar and with oil. For oil-free performances are -10 to 15% lower. Data tolerance accuracy +-10%

  II2 GD c IIC T6 (80°C) X

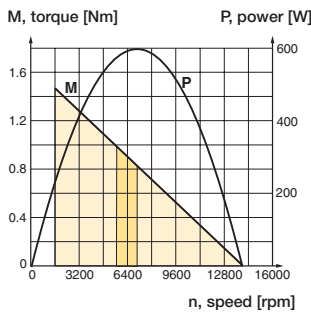


**Reversible air motor with keyed shaft, P1V-S060A series**

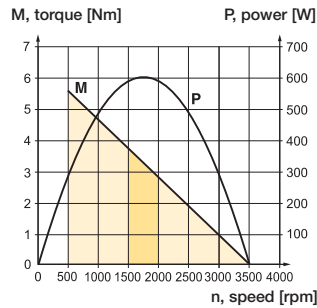
Max power kW	Free speed* rpm	Nominal speed rpm	Nominal torque Nm	Min start torque Nm	Air consumption at max power l/s	Conn.	Min pipe ID mm	Weight Kg	Part number
0.60	14,000	7,000	0.82	1.23	14.2	G3/8	12	2.20	<b>P1V-S060A0E00</b>
0.60	3,500	1,750	3.20	4.80	14.2	G3/8	12	2.30	<b>P1V-S060A0350</b>
0.60	2,700	1,350	4.20	6.40	14.2	G3/8	12	2.30	<b>P1V-S060A0270</b>
0.60	1,700	850	6.70	10.10	14.2	G3/8	12	2.30	<b>P1V-S060A0170</b>
0.60	630	315	18.00	27.00	14.2	G3/8	12	2.60	<b>P1V-S060A0063</b>
0.60	480	240	24.00	36.00	14.2	G3/8	12	2.70	<b>P1V-S060A0048</b>
0.60	300	150	38.00	57.00	14.2	G3/8	12	2.70	<b>P1V-S060A0030</b>
0.30	150	75	38.00	57.00	14.2	G3/8	12	2.70	<b>P1V-S060A0015</b>

\* maximum admissible speed (idling)

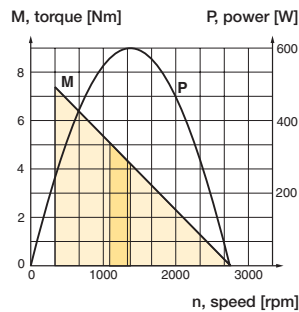
**P1V-S060A0E00**



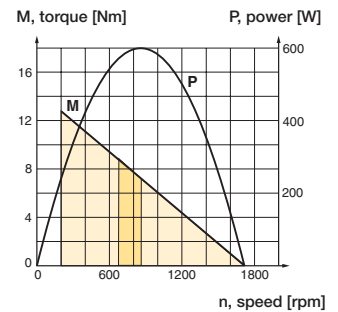
**P1V-S060A0350**



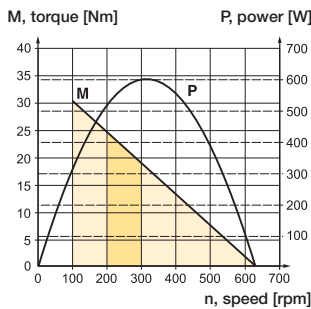
**P1V-S060A0270**



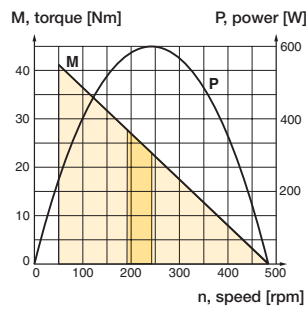
**P1V-S060A0170**



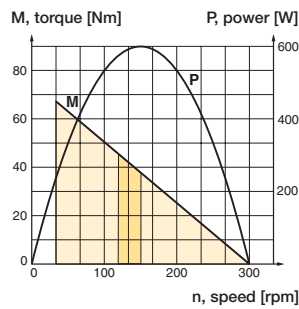
**P1V-S060A0063**



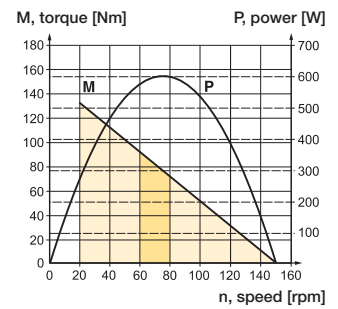
**P1V-S060A0048**



**P1V-S060A0030**



**P1V-S060A0015**



 Possible working range of motor.

 Optimum working range of motor.

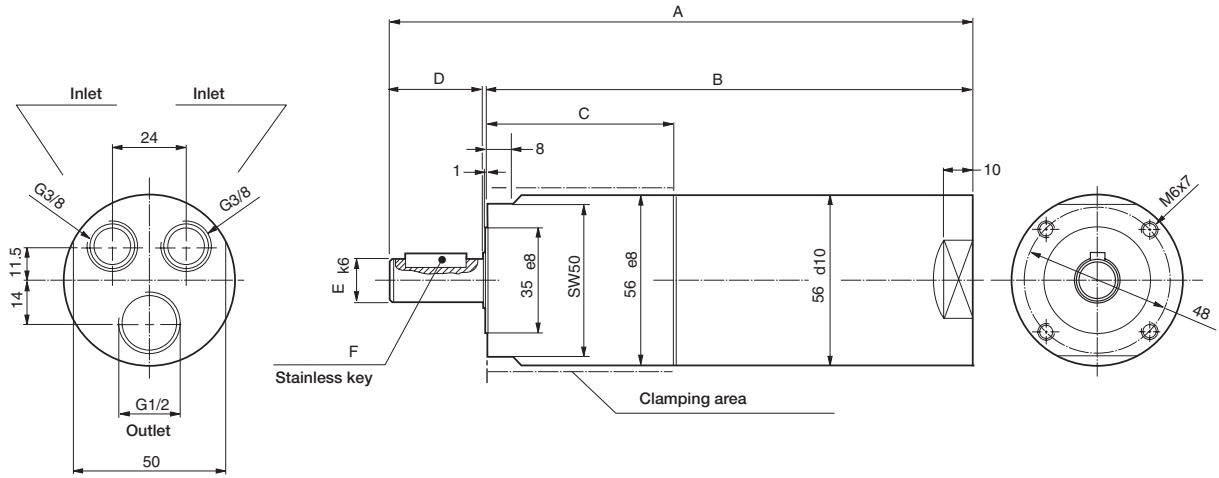
Higher speeds = more vane wear

Lower speeds with high torque = more gearbox wear



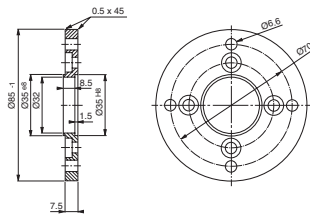
For inventory, lead times, and kit lookup, visit [www.pdnplu.com](http://www.pdnplu.com)

**Motor P1V-S060**

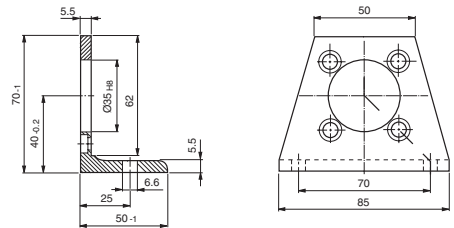


	A	B	C	D	E	F
P1V-S060A0E00	197	165.5	66	30	14	A5x5x20 DIN 6885
P1V-S060A0350	197	165.5	66	30.5	14	A5x5x20 DIN 6885
P1V-S060A0270	197	165.5	66	30.5	14	A5x5x20 DIN 6885
P1V-S060A0170	197	165.5	66	30.5	14	A5x5x20 DIN 6885
P1V-S060A0063	215	183.5	84	30.5	14	A5x5x20 DIN 6885
P1V-S060A0048	217	180.0	80.5	36	19	A6x6x22 DIN 6885
P1V-S060A0030	217	180.0	80.5	36	19	A6x6x22 DIN 6885
P1V-S060A0015	217	180.0	80	35	19	A6x6x22 DIN 6885

**Flange  
P1V-S4060B**



**Foot bracket  
P1V-S4060F**



Stainless Steel

Stainless Steel  
with Brakes

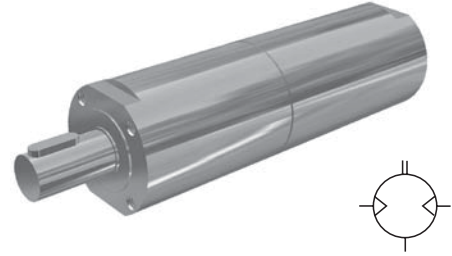
High Torque  
Stainless Steel

Drilling, Milling &  
Grinding

Air Motors



**NOTE!** All technical data are based on a working pressure of 6 bar and with oil. For oil-free performances are -10 to 15% lower. Data tolerance accuracy +-10%



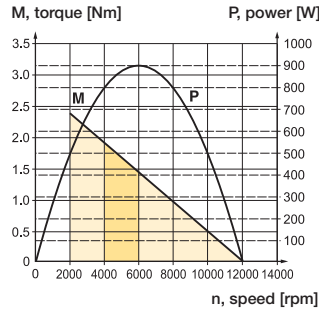
II2 GD c IIC T6 (80°C) X

**Reversible air motor with keyed shaft, P1V-S090A series**

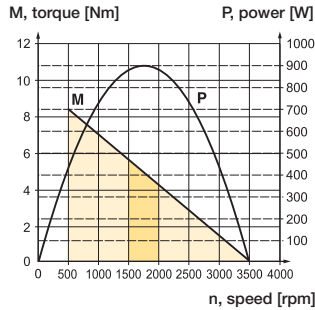
Max power kW	Free speed* rpm	Nominal speed rpm	Nominal torque Nm	Min start torque Nm	Air consumption at max power l/s	Conn.	Min pipe ID mm	Weight Kg	Part number
0.90	12,000	6,000	1.4	2.1	23.3	G1/2	12	2.50	<b>P1V-S090A0C00</b>
0.90	3,500	1,750	4.9	7.3	23.3	G1/2	12	2.60	<b>P1V-S090A0350</b>
0.90	2,700	1,350	6.3	9.5	23.3	G1/2	12	2.60	<b>P1V-S090A0270</b>
0.90	1,700	850	10.1	15.2	23.3	G1/2	12	2.60	<b>P1V-S090A0170</b>
0.90	630	315	27.0	40.0	23.3	G1/2	12	2.90	<b>P1V-S090A0063</b>
0.90	480	240	35.0	53.0	23.3	G1/2	12	3.00	<b>P1V-S090A0048</b>
0.90	300	150	57.0	85.0	23.3	G1/2	12	3.00	<b>P1V-S090A0030</b>

\* maximum admissible speed (idling)  
\*\* Max permitted torque to not damage the gearbox.

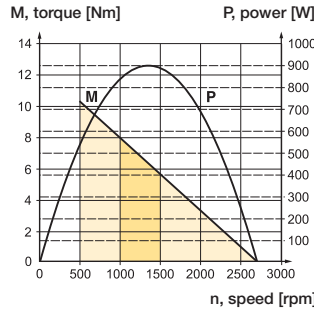
**P1V-S090A0C00**



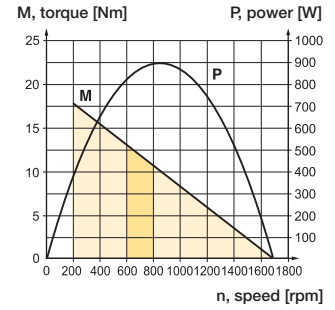
**P1V-S090A0350**



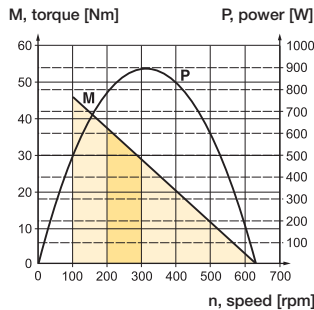
**P1V-S090A0270**



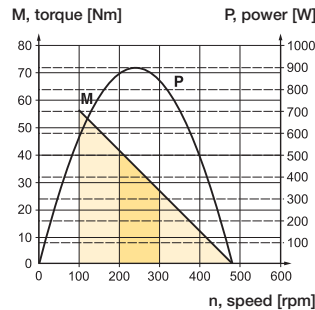
**P1V-S090A0170**



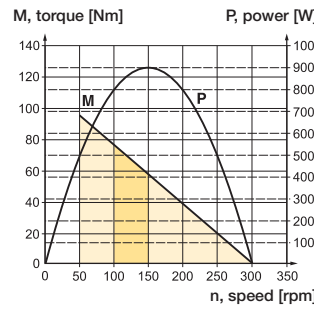
**P1V-S090A0063**



**P1V-S090A0048**



**P1V-S090A0030**



Possible working range of motor.

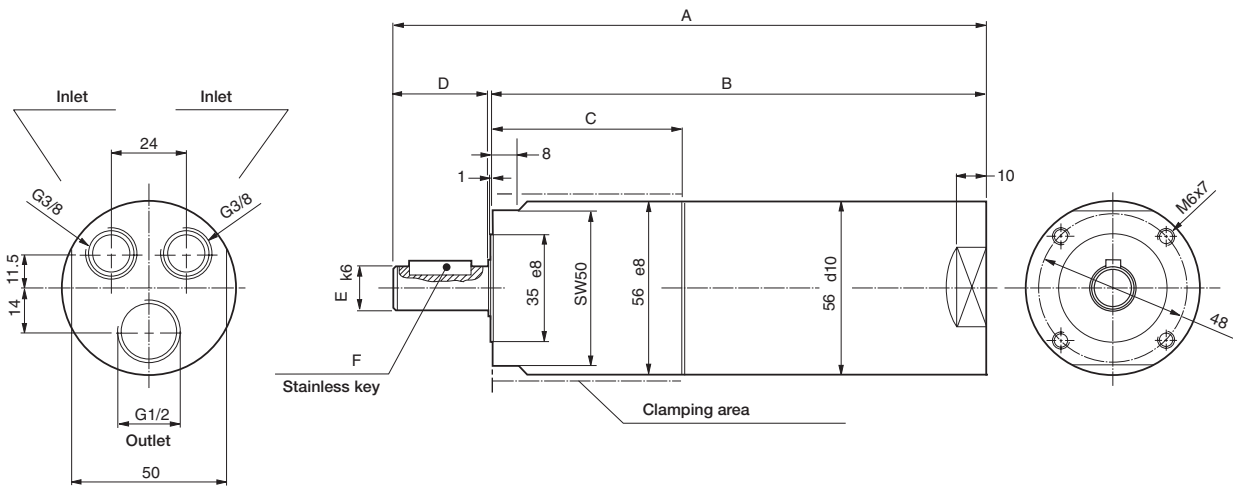
Optimum working range of motor.

Higher speeds = more vane wear  
Lower speeds with high torque = more gearbox wear



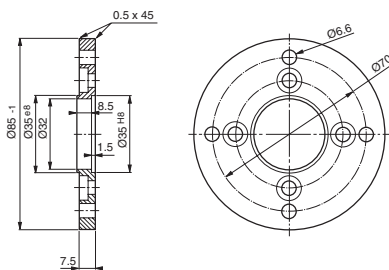
For inventory, lead times, and kit lookup, visit [www.pdnplu.com](http://www.pdnplu.com)

**Motor P1V-S090**

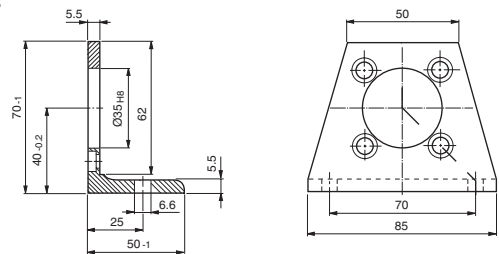


	A	B	C	D	E	F
P1V-S090A0C00	217	185.5	67	30.5	14	A5x5x20 DIN 6885
P1V-S090A0350	217	185.5	67	30.5	14	A5x5x20 DIN 6885
P1V-S090A0270	217	185.5	67	30.5	14	A5x5x20 DIN 6885
P1V-S090A0170	217	185.5	67	30.5	14	A5x5x20 DIN 6885
P1V-S090A0063	235	203.5	85	30.5	14	A5x5x20 DIN 6885
P1V-S090A0048	237	200.0	81	36	19	A6x6x22 DIN 6885
P1V-S090A0030	237	200.0	81	36	19	A6x6x22 DIN 6885
P1V-S060A0015	217	180.0	80	35	19	A6x6x22 DIN 6885

**Flange**  
**P1V-S4060B**

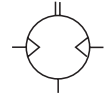
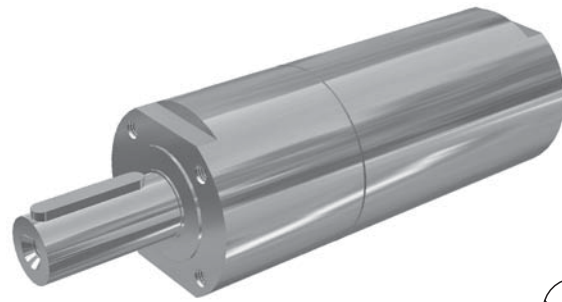


**Foot bracket**  
**P1V-S4060F**



**NOTE!** All technical data are based on a working pressure of 6 bar and with oil. For oil-free performances are -10 to 15% lower. Data tolerance accuracy +-10%

CE II2 GD c IIC T6 (95°C) X

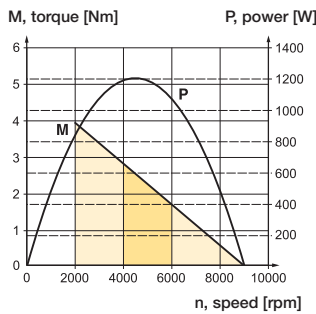


**Reversible air motor with keyed shaft, P1V-S120A series**

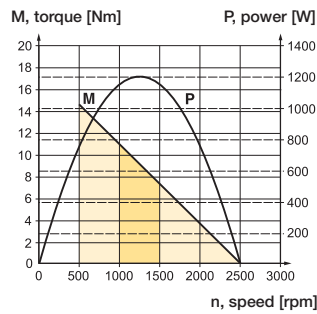
Max power kW	Free speed* rpm	Nominal speed rpm	Nominal torque Nm	Min start torque Nm	Air consumption at max power l/s	Conn.	Min pipe ID mm	Weight Kg	Part number
1.20	9,000	4,500	2.5	3.8	26.7	G3/4	19	5.5	<b>P1V-S120A0900</b>
1.20	2,500	1,250	9.2	13.7	26.7	G3/4	19	5.5	<b>P1V-S120A0250</b>
1.20	1,100	550	21.0	31.0	26.7	G3/4	19	6.1	<b>P1V-S120A0110</b>
1.20	700	350	33.0	49.0	26.7	G3/4	19	5.6	<b>P1V-S120A0070</b>
1.20	320	160	71.0	107.0	26.7	G3/4	19	6.7	<b>P1V-S120A0032</b>
0.70	200	100	66.9	100.0	19	G3/4	19	6.7	<b>P1V-S120A0020</b>

\* maximum admissible speed (idling)

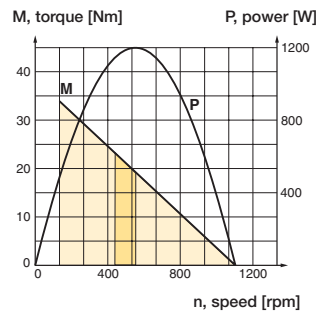
**P1V-S120A0900**



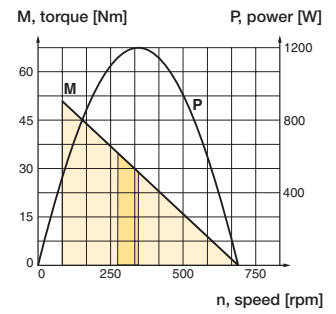
**P1V-S120A0250**



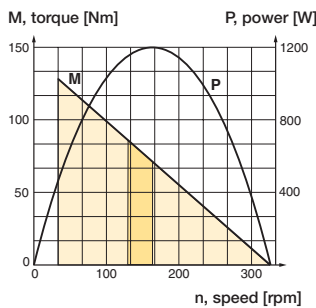
**P1V-S120A0110**



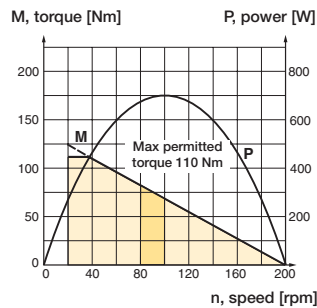
**P1V-S120A0070**



**P1V-S120A0032**



**P1V-S120A0020**



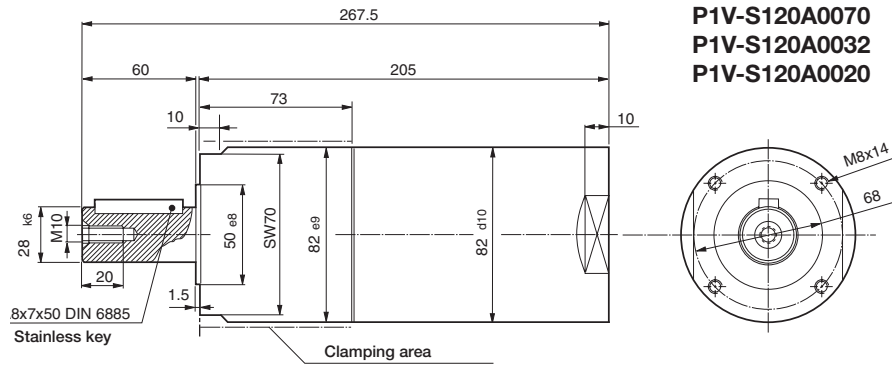
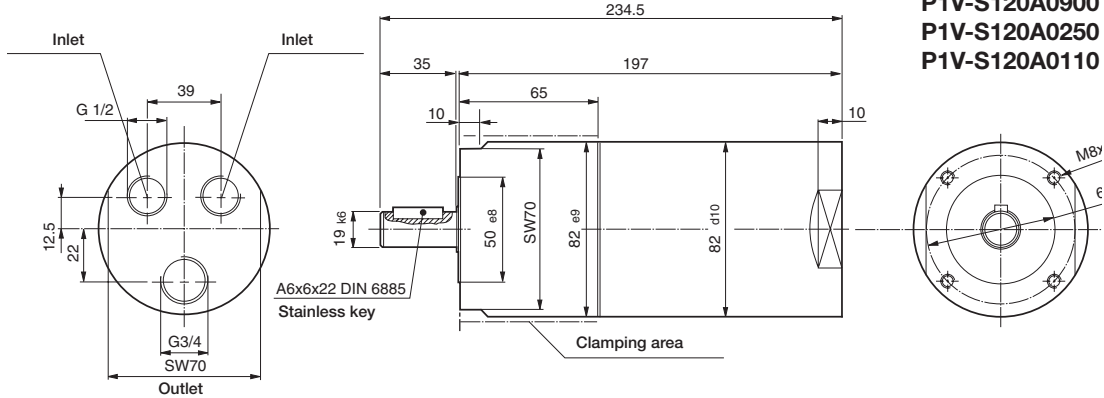
Possible working range of motor.  
 Optimum working range of motor.  
 Higher speeds = more vane wear  
 Lower speeds with high torque = more gearbox wear



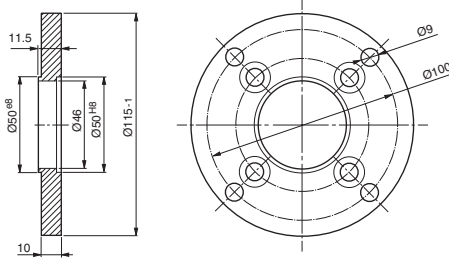
For inventory, lead times, and kit lookup, visit [www.pdnplu.com](http://www.pdnplu.com)



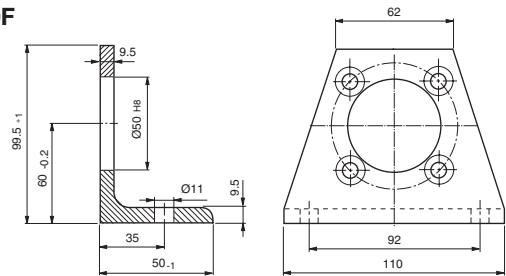
**Motor P1V-S120**



**Flange**  
**P1V-S4120B**



**Foot bracket**  
**P1V-S4120F**



Stainless Steel

Stainless Steel  
with Brakes

High Torque  
Stainless Steel

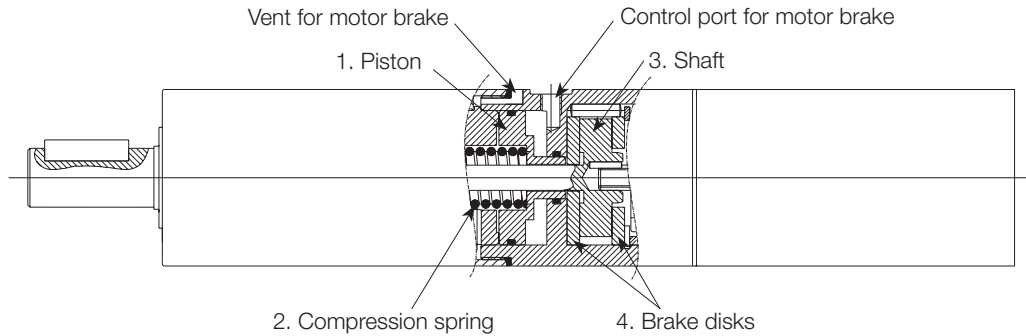
Drilling, Milling &  
Grinding

Air Motors



Features

P1V-S stainless steel with brake type - 200, 300 & 1200 Watts



Applications

The integrated brake is a spring-loaded disk brake, which is released at a minimum air pressure of 5 bar. The brake is applied in the absence of pressure. As soon as the control port for the brake is placed under pressure, the piston (1) is pressurised and the spring (2) is compressed. The motor can now start and the torque is passed to the shaft (3). The ventilation air from the brake is connected with the atmosphere. In order to brake the motor, the control air to the brake is simply vented. The piston (1) is pushed to the right by the spring (2), and the axle (3) is jammed between the two brake disks (4).

The technology and the size of air motors with stationary brake make them ideal for applications requiring short stops after having cutting air pressure inside the air motors for blocking the rotation. Another typical application for brake motors is when the output shaft needs to be held in one position when the motor stops delivering torque and must stay in position. The brake can handle more than 1500 braking operations per hour at maximum braking torque.

Disassembly and Reassembly

Detach the connections with the motor and gearbox. Pull off the motor and gearbox part. The brake disks can be lifted off after the lock ring has been removed.

Service and Maintenance

After 20,000 braking operations as a stationary brake or 10,000 braking operations as an operating brake, the brake must be disassembled in order to check for wear.

Warning:

If the number of braking operations is exceeded, the degree of wear might be greater than permitted and the braking effect might be lost. If this happens, you simply need to replace the worn brake linings. Tests show that the brake lining needs to be replaced after approx. 90,000 braking cycles.

**NOTE!** Brake motors must only ever be supplied with unlubricated air, otherwise there is a risk of oil from the supply air getting into the brake unit, resulting in poor brake performance or no braking effect.

Air motor size & type	200 watts, ●●● = 020		300 watts, ●●● = 030		1200 watts, ●●● = 120	
	Motor Max torque Nm	Theoretical min braking torque Nm	Motor Max torque Nm	Theoretical min braking torque Nm	Motor Max torque Nm	Theoretical min braking torque Nm
P1V-S●●●ADE50	0.52	1	0.8	1	–	–
P1V-S120AD900	–	–	–	–	5	6.2
P1V-S●●●AD460	1.6	3.4	2.4	34	–	–
P1V-S120AD250	–	–	–	–	18.4	2.3
P1V-S●●●AD240	3.2	6.7	4.8	6.7	–	–
P1V-S●●●AD140	5.4	11.8	8.2	11.8	–	–
P1V-S120AD110	–	–	–	–	42	52
P1V-S●●●AD070	10.8	20	–	–	66	83
P1V-S●●●AD034	–	–	19.2	36	–	–
P1V-S●●●AD032	24	44.4	–	–	142	177
P1V-S030AD023	–	–	48	70.8	–	–
P1V-S●●●AD018	21	44.4	47.2	123.6	–	–
P1V-S020AD011	66	137.2	–	–	–	–
P1V-S030AD010	–	–	114	123.6	–	–
P1V-S020AD006	144	266.4	–	–	–	–
P1V-S●●●AD005	20*	44.4	36*	40	–	–
P1V-S020AD002	20*	44.4	–	–	–	–
P1V-S020AD001	20*	44.4	–	–	–	–
P1V-S020AD0005	20*	44.4	–	–	–	–

\*Warning ! : the permitted torque for the specific gearbox must not be exceeded.  
Brake release: minimum air pressure of 5 bar



For inventory, lead times, and kit lookup, visit [www.pdnplu.com](http://www.pdnplu.com)

Air motor size & type	P1V-S020	P1V-S030	P1V-S120
Nominal power (watts)	200	300	1200
Working pressure (bar)	3 to 7.6 in explosive atmosphere (with brake not atex certified)		
Working temperature (°C)	-20 to +110		
Ambient temperature (°C)	-20 to +40 in explosive atmosphere (with brake not atex certified)		
Air flow required (NI/min)	370	470	1600
Min pipe ID, inlet (mm)	10	10	19
Min pipe ID, outlet (mm)	10	10	19

**Choice of treatment unit: recommended min air flow (l/min) at p1 7.5 bar and 0.8 bar pressure drop**

	120	120	1800
Medium	40 µm filtered, oil mist or dry unlubricated compressed air		
Oil free operation, indoor	ISO8573-1 purity class 3.4.1		
Oil free operation, outdoor	ISO8573-1 purity class 1.2.1		
Oil operation	1-2 drop per cube meter, ISO8573-1 purity class 3.-.5		
Recommended oil	Foodstuffs industry Klüber oil 4 UH1- 32 N		

**Choice of valve: recommended min nominal air flow (l/min) at p1 6 bar and 1 bar pressure drop**

	450	550	2000
Sound level free outlet (dB(A))	100	103	108
With outlet silencer (dB(A))	82	91	95
Exhaust air removed with pipes to another room	71	70	87

**Note:** Sound levels are measured at free speed with the measuring instrument positioned 1 meter away from the air motor at an height of 1 meter.

**Table and diagram data**

All technical data are based on a working pressure of 6 bar and with oil. Oil-free performances are -10 to 15% lower.  
Data tolerance accuracy +-10%

**Material specification**

Air motor size & type	P1V-S020	P1V-S030	P1V-S120
Planetary gearbox housing	Stainless steel		
Planetary gearbox housing for last planet stage including installation flange	Stainless steel or Black oxidized steel (not stainless)		Stainless steel
Air motor housing	Stainless steel		
Shaft	Hardened stainless steel		
Key	Hardened stainless steel		
External seal Fluor rubber	Fluor rubber FPM		
Internal steel parts	High grade steel (not stainless)		
Planetary gear grease used in	Grease, Shell Cassida RLS2		
Screws in housing in last planet stage	Surface treated steel (not stainless)		

**Accessories****P1V**

Flange bracket	Stainless steel
Foot bracket	Stainless steel
Screws for the mountings	Stainless steel DIN A2

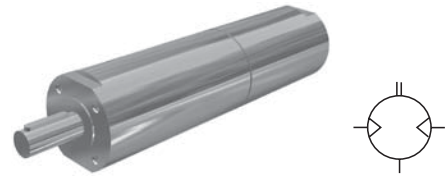


For inventory, lead time, and kit lookup, visit [www.pdnplu.com](http://www.pdnplu.com)

J33

**Parker Hannifin Corporation**  
Pneumatic Division  
Richland, Michigan  
[www.parker.com/pneumatics](http://www.parker.com/pneumatics)

**NOTE!** All technical data are based on a working pressure of 6 bar and with oil. For oil-free performances are -10 to 15% lower. Data tolerance accuracy +/-10%



**IMPORTANT! Non Atex certified**

**Reversible brake motor with keyed shaft, P1V-S020AD series**

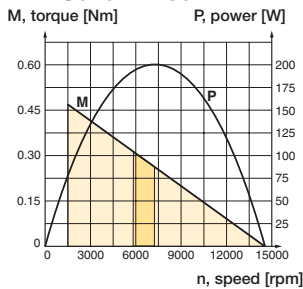
Max power kW	Free speed* rpm	Nominal speed rpm	Nominal torque Nm	Min start torque Nm	Air consumption at max power l/s	Conn.	Min pipe ID mm	Weight Kg	Part number
0.20	14,500	7,250	0.26	0.40	6.2	G1/8	10	1.00	<b>P1V-S020ADE50</b>
0.20	4,600	2,300	0.80	1.20	6.2	G1/8	10	1.05	<b>P1V-S020AD460</b>
0.20	2,400	1,200	1.60	2.40	6.2	G1/8	10	1.05	<b>P1V-S020AD240</b>
0.20	1,400	700	2.70	4.10	6.2	G1/8	10	1.15	<b>P1V-S020AD140</b>
0.20	700	350	5.40	8.20	6.2	G1/8	10	1.15	<b>P1V-S020AD070</b>
0.20	320	160	12.00	18.00	6.2	G1/8	10	1.15	<b>P1V-S020AD032</b>
0.10	180	90	10.50	15.00	4.5	G1/8	10	1.15	<b>P1V-S020AD018</b>
0.18	50	25	20.00**	20.00**	6.2	G1/8	10	1.25	<b>P1V-S020AD005</b>
0.18	20	-	20.00**	20.00**	6.2	G1/8	10	1.25	<b>P1V-S020AD002</b>
0.18	10	-	20.00**	20.00**	6.2	G1/8	10	1.35	<b>P1V-S020AD001</b>
0.18	5	-	20.00**	20.00**	6.2	G1/8	10	1.35	<b>P1V-S020AD0005</b>

\* maximum admissible speed (idling)

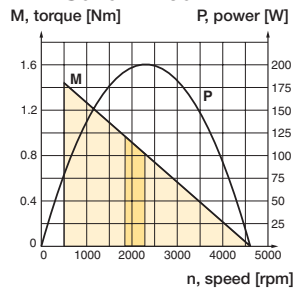
\*\* Max permitted torque for the gearbox

The P1V-S020D with threaded shaft may be reversed, but when operated counter-clockwise, there is a risk that the driven unit may disconnect if it is not locked properly.

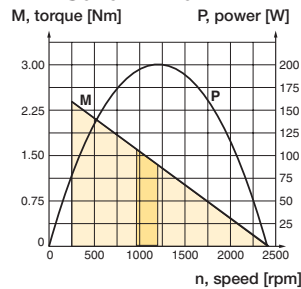
**P1V-S020ADE50**



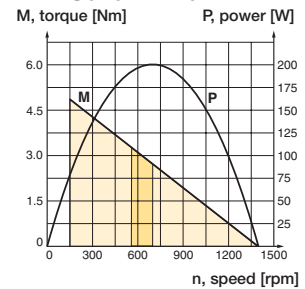
**P1V-S020AD460**



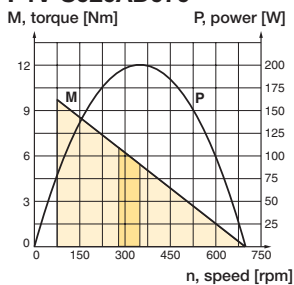
**P1V-S020AD240**



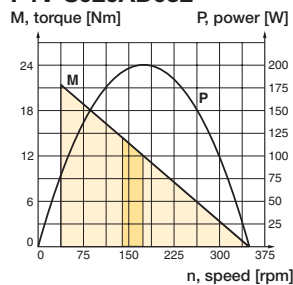
**P1V-S020AD140**



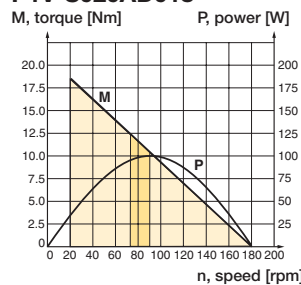
**P1V-S020AD070**



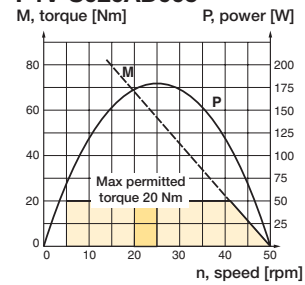
**P1V-S020AD032**



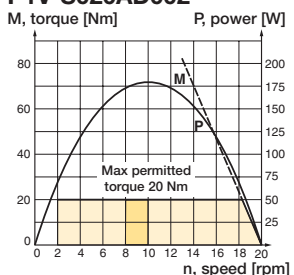
**P1V-S020AD018**



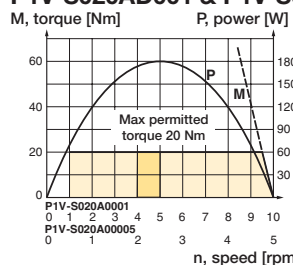
**P1V-S020AD005**



**P1V-S020AD002**



**P1V-S020AD001 & P1V-S020AD0005**

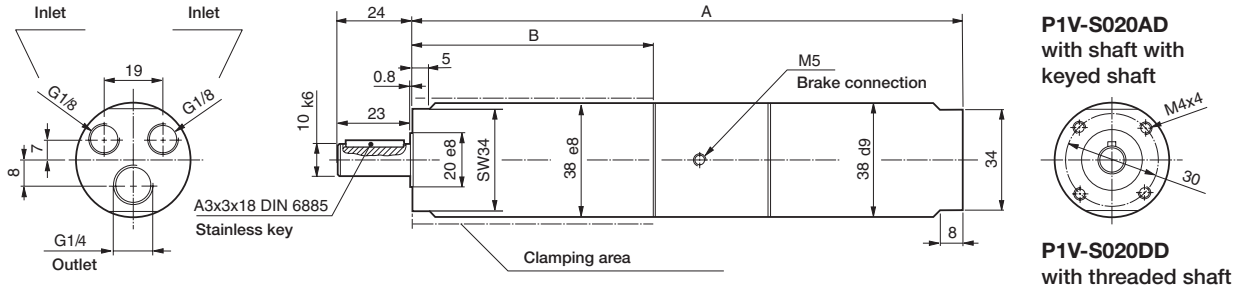


Possible working range of motor.  
 Optimum working range of motor.  
 Higher speeds = more vane wear  
 Lower speeds with high torque = more gearbox wear



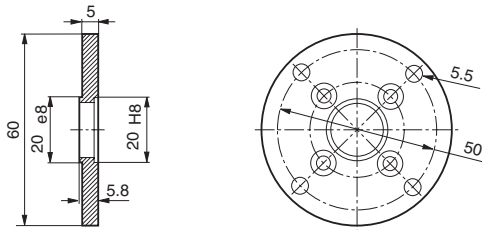
For inventory, lead times, and kit lookup, visit [www.pdnplu.com](http://www.pdnplu.com)

Brake motor P1V-S020

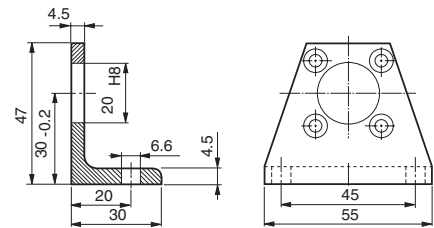


	A	B
P1V-S020ADE50	170	63.5
P1V-S020AD460	170	63.5
P1V-S020AD240	170	63.5
P1V-S020AD140	186	79.5
P1V-S020AD070	186	79.5
P1V-S020AD032	186	79.5
P1V-S020AD018	186	79.5
P1V-S020AD005	202	95.5
P1V-S020AD002	202	95.5
P1V-S020AD001	218	111.5
P1V-S020AD0005	218	111.5

Flange  
P1V-S4020B



Foot bracket  
P1V-S4020F



Stainless Steel

Stainless Steel  
with Brakes

High Torque  
Stainless Steel

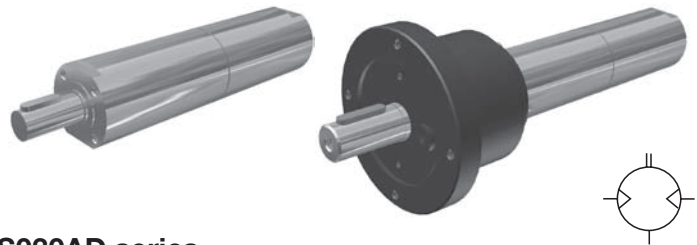
Drilling, Milling &  
Grinding

Air Motors



For inventory, lead time, and kit lookup, visit [www.pdnplu.com](http://www.pdnplu.com)

**NOTE!** All technical data are based on a working pressure of 6 bar and with oil. For oil-free performances are -10 to 15% lower. Data tolerance accuracy +-10%



**IMPORTANT! Non Atex certified**

**Reversible brake motor with keyed shaft, P1V-S030AD series**

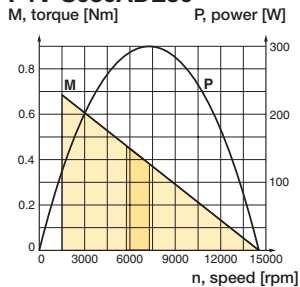
Max power kW	Free speed* rpm	Nominal speed rpm	Nominal torque Nm	Min start torque Nm	Air consumption at max power l/s	Conn.	Min pipe ID mm	Weight Kg	Part number
0.30	14,500	7,250	0.40	0.60	8.0	G1/4	10	1.35	<b>P1V-S030ADE50</b>
0.30	4,600	2,300	1.20	1.90	8.0	G1/4	10	1.40	<b>P1V-S030AD460</b>
0.30	2,400	1,200	2.40	3.60	8.0	G1/4	10	1.40	<b>P1V-S030AD240</b>
0.30	1,400	700	4.10	6.10	8.0	G1/4	10	1.45	<b>P1V-S030AD140</b>
0.30	600	300	9.60	14.30	8.0	G1/4	10	1.50	<b>P1V-S030AD060</b>
0.30	340	170	16.90	25.30	8.0	G1/4	10	1.50	<b>P1V-S030AD034</b>
0.30	230	115	24.00	36**	8.0	G1/4	10	3.65	<b>P1V-S030AD023</b>
0.13	180	90	13.80	21.00	4.7	G1/4	10	1.15	<b>P1V-S030AD018</b>
0.30	100	50	57.00	85.50	8.0	G1/4	10	3.65	<b>P1V-S030AD010</b>
0.28	50	25	36**	36**	8.0	G1/4	10	1.60	<b>P1V-S030AD005</b>

\* maximum admissible speed (idling)

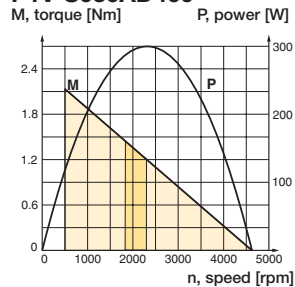
\*\* Max permitted torque for the gearbox

The P1V-S030D with threaded shaft may be reversed, but when operated counter-clockwise, there is a risk that the driven unit may disconnect if it is not locked properly.

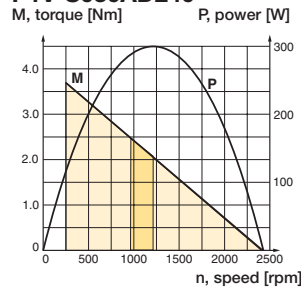
**P1V-S030ADE50**



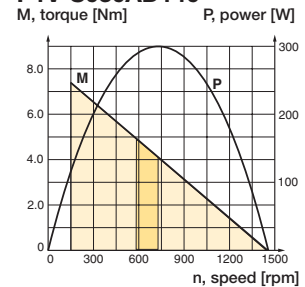
**P1V-S030AD460**



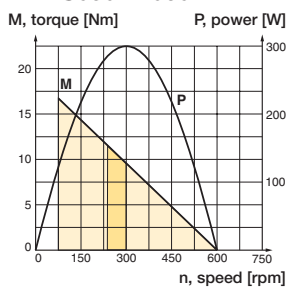
**P1V-S030AD240**



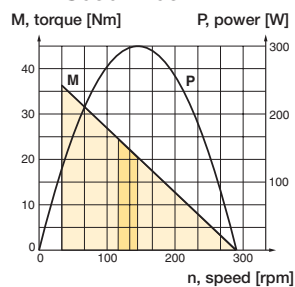
**P1V-S030AD140**



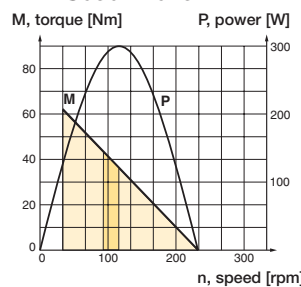
**P1V-S030AD060**



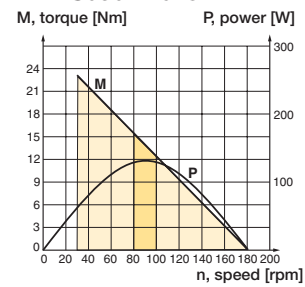
**P1V-S030AD034**



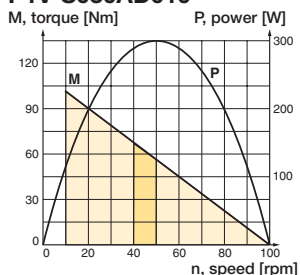
**P1V-S030AD023**



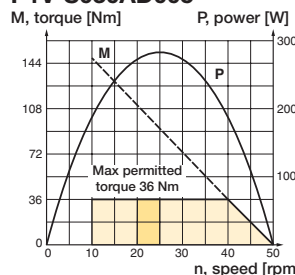
**P1V-S030AD018**



**P1V-S030AD010**



**P1V-S030AD005**



Possible working range of motor.

Optimum working range of motor.

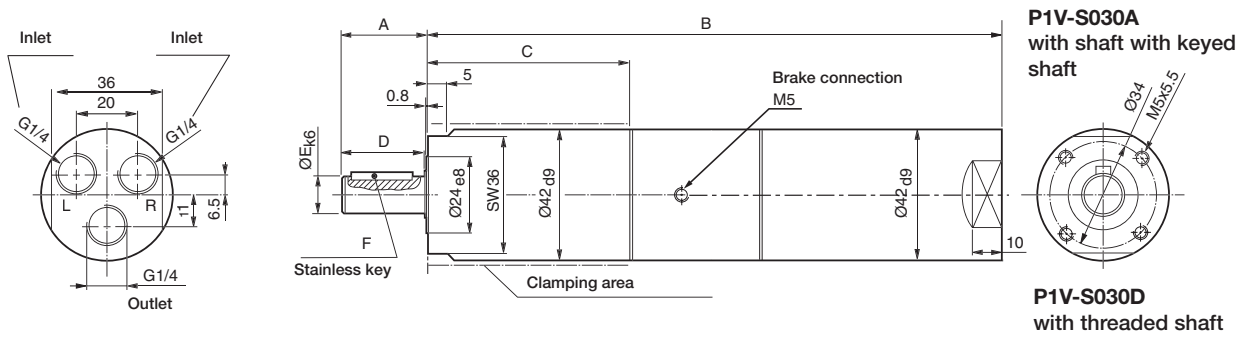
Higher speeds = more vane wear

Lower speeds with high torque = more gearbox wear



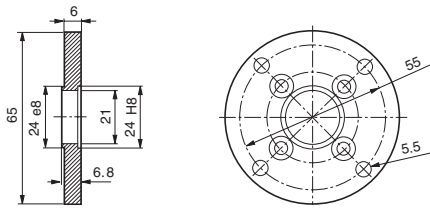
For inventory, lead times, and kit lookup, visit [www.pdnplu.com](http://www.pdnplu.com)

Brake motor P1V-S030

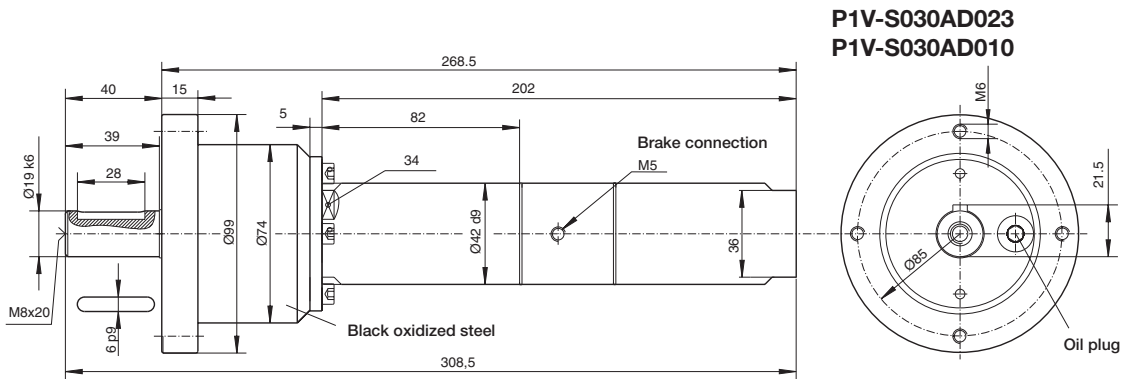
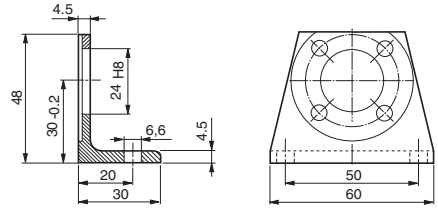


	A	B	C	D	E	F
P1V-S030ADE50	28.5	186	66	27	12	A4x4x20 DIN 6885
P1V-S030AD460	28.5	186	66	27	12	A4x4x20 DIN 6885
P1V-S030AD240	28.5	186	66	27	12	A4x4x20 DIN 6885
P1V-S030AD140	28.5	202	82	27	12	A4x4x20 DIN 6885
P1V-S030AD060	32.0	202	82	30	14	A5x5x20 DIN 6885
P1V-S030AD034	32.0	202	82	30	14	A5x5x20 DIN 6885
P1V-S030AD018	32.0	202	82	30	14	A5x5x20 DIN 6885
P1V-S030AD005	32.0	207	82	30	14	A5x5x20 DIN 6885

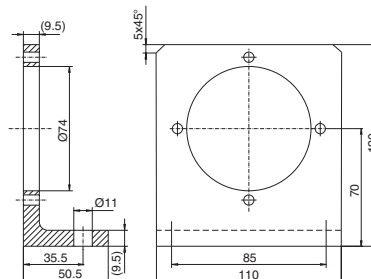
Flange  
P1V-S4030B



Foot bracket  
P1V-S4030F



Foot bracket for motors  
P1V-S030AD0023 and P1V-S030AD0010  
P1V-S4020C



Stainless Steel  
Stainless Steel with Brakes  
High Torque Stainless Steel  
Drilling, Milling & Grinding  
Air Motors

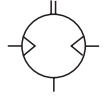


For inventory, lead time, and kit lookup, visit [www.pdnplu.com](http://www.pdnplu.com)

Specifications – 1200 Watts

**NOTE!** All technical data are based on a working pressure of 6 bar and with oil. For oil-free performances are -10 to 15% lower. Data tolerance accuracy +-10%

**IMPORTANT! Non Atex certified**

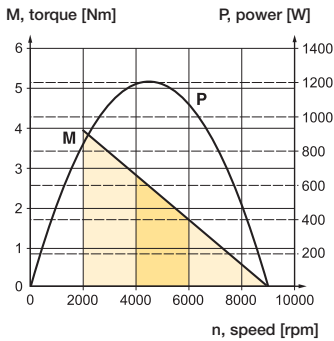


Reversible brake motor with keyed shaft, P1V-S120AD series

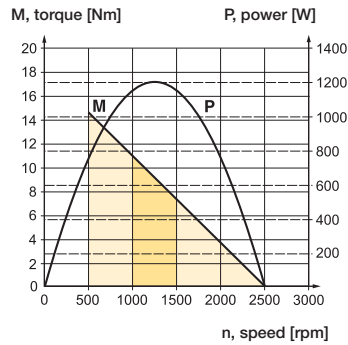
Max power kW	Free speed* rpm	Nominal speed rpm	Nominal torque Nm	Min start torque Nm	Air consumption at max power l/s	Conn.	Min pipe ID mm	Weight Kg	Part number
1.20	9,000	4,500	2.50	3.80	26.7	G3/4	19	9.00	<b>P1V-S120AD900</b>
1.20	2,500	1,250	9.20	13.70	26.7	G3/4	19	9.20	<b>P1V-S120AD250</b>
1.20	1,100	550	21.00	31.00	26.7	G3/4	19	9.20	<b>P1V-S120AD110</b>
1.20	700	350	33.00	49.00	26.7	G3/4	19	9.70	<b>P1V-S120AD070</b>
1.20	320	160	71.00	107.00	26.7	G3/4	19	9.70	<b>P1V-S120AD032</b>

\* maximum admissible speed (idling)

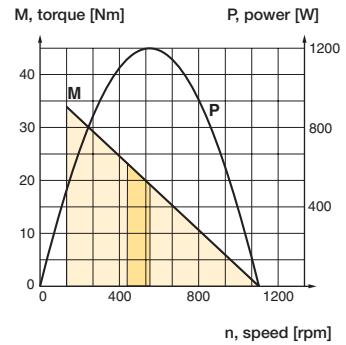
**P1V-S120AD900**



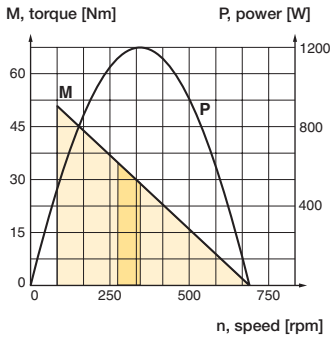
**P1V-S120AD250**



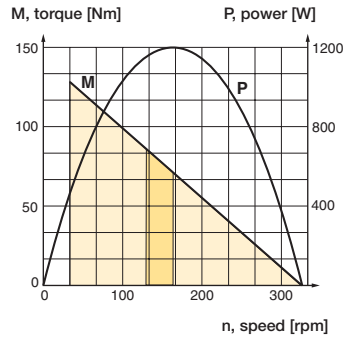
**P1V-S120AD110**



**P1V-S120AD070**



**P1V-S120AD032**



Possible working range of motor.

Optimum working range of motor.

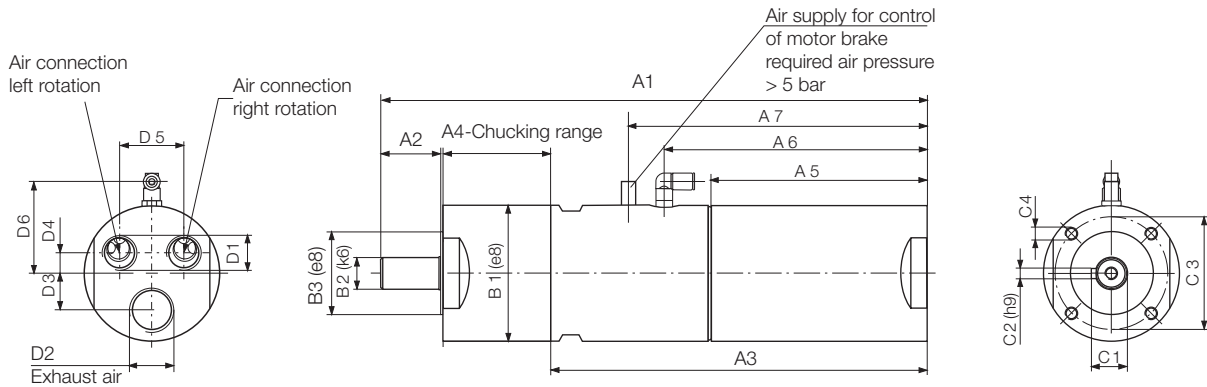
Higher speeds = more vane wear  
Lower speeds with high torque = more gearbox wear



For inventory, lead times, and kit lookup, visit [www.pdnplu.com](http://www.pdnplu.com)

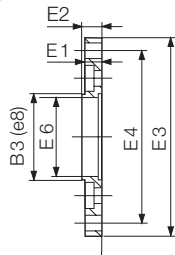


**Brake motor P1V-S120**

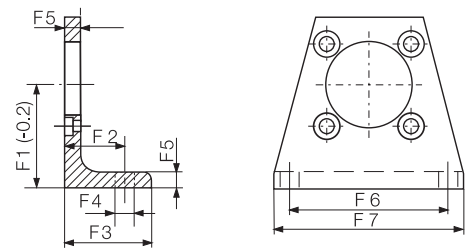


	A	B	C	D	E	F
P1V-S120AD900	28.5	186	66	27	12	A4x4x20 DIN 6885
P1V-S120AD250	28.5	186	66	27	12	A4x4x20 DIN 6885
P1V-S120AD110	28.5	186	66	27	12	A4x4x20 DIN 6885
P1V-S120AD070	28.5	202	82	27	12	A4x4x20 DIN 6885
P1V-S120AD032	32.0	202	82	30	14	A5x5x20 DIN 6885

**Flange  
P1V-S4120B**



**Foot bracket  
P1V-S4120F**



Stainless Steel

Stainless Steel  
with Brakes

High Torque  
Stainless Steel

Drilling, Milling &  
Grinding

Air Motors



For inventory, lead time, and kit lookup, visit [www.pdnplu.com](http://www.pdnplu.com)



For inventory, lead times, and kit lookup, visit [www.pdnplu.com](http://www.pdnplu.com)

J40

**Parker Hannifin Corporation**  
Pneumatic Division  
Richland, Michigan  
[www.parker.com/pneumatics](http://www.parker.com/pneumatics)

Air motor size & type	P1V-S028	P1V-S057	P1V-S086
Nominal power (watts)	285	570	860
Working pressure (bar)	3 to 7.6 in explosive atmosphere (with brake not atex certified)		
Working temperature (°C)	-20 to +110		
Ambient temperature (°C)	-20 to +40 in explosive atmosphere (with brake not atex certified)		
Air flow required (NI/min)	470	850	1400
Min pipe ID, inlet (mm)	10	12	12
Min pipe ID, outlet (mm)	10	12	12

**Choice of treatment unit: recommended min air flow (l/min) at p1 7.5 bar and 0.8 bar pressure drop**

	510	900	1500
Medium	40 µm filtered, oil mist or dry unlubricated compressed air		
Oil free operation, indoor	ISO8573-1 purity class 3.4.1		
Oil free operation, outdoor	ISO8573-1 purity class 1.2.1		
Oil operation	1-2 drop per cube meter, ISO8573-1 purity class 3.-.5		
Recommended oil	Foodstuffs industry Klüber oil 4 UH1- 32 N		

**Choice of valve: recommended min nominal air flow (l/min) at p1 6 bar and 1 bar pressure drop**

	550	950	1600
Sound level free outlet (dB(A))	103	103	106
With outlet silencer (dB(A))	91	94	88
Exhaust air removed with pipes to another room	70	76	80

**Note:** Sound levels are measured at free speed with the measuring instrument positioned 1 meter away from the air motor at an height of 1 meter.

**Table and diagram data**

All technical data are based on a working pressure of 6 bar and with oil. Oil-free performances are -10 to 15% lower.  
Data tolerance accuracy +-10%

**Material specification**

Air motor size & type	P1V-S028	P1V-S057	P1V-S086
Planetary gearbox housing	Stainless steel		
Air motor housing	Stainless steel		
Shaft	Hardened stainless steel		
Key	Hardened stainless steel		
External seal Fluor rubber	Fluor rubber FPM		
Internal steel parts	High grade steel (not stainless)		
Planetary gear grease used in	Grease, Shell Cassida RLS2		
Screws in housing in last planet stage	Surface treated steel (not stainless)		

**Accessories****P1V**

Flange bracket	Stainless steel
Foot bracket	Stainless steel
Screws for the mountings	Stainless steel DIN A2

Stainless Steel

Stainless Steel  
with BrakesHigh Torque  
Stainless SteelDrilling, Milling &  
Grinding

Air Motors



For inventory, lead time, and kit lookup, visit [www.pdnplu.com](http://www.pdnplu.com)

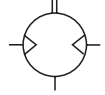
J41

**Parker Hannifin Corporation**  
Pneumatic Division  
Richland, Michigan  
[www.parker.com/pneumatics](http://www.parker.com/pneumatics)

**Specifications – 285 Watts**

**P1V-S Stainless Steel High Torque Type**

The high torque motors of the P1V-S type are small in size but provide extremely high output. Our high torque motors are also less apt to stall. These drive solutions are particularly suitable for use in industrial agitators and mixers as used in the paint industry, food industry or pharmaceutical industry.



**NOTE!** All technical data are based on a working pressure of 6 bar and with oil. For oil-free performances are -10 to 15% lower. Data tolerance accuracy +-10%

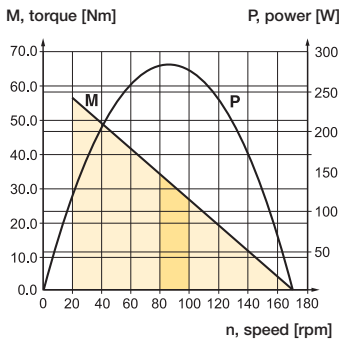
CE Ex II2 GD c IIC T6 (80°C) X

**Reversible air motor with keyed shaft, P1V-S028A series**

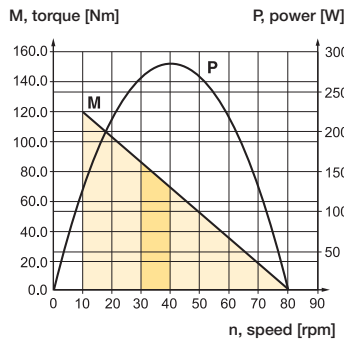
Max power kW	Free speed* rpm	Nominal speed rpm	Nominal torque Nm	Min start torque Nm	Air consumption at max power l/s	Conn.	Min pipe ID mm	Weight Kg	Part number
0.285	170	85	32	47	7.8	G3/8	10	2.70	<b>P1V-S028A0017</b>
0.285	80	40	62	92	7.8	G3/8	10	2.60	<b>P1V-S028A0008</b>
0.285	50	25	110	162	7.8	G3/8	10	2.90	<b>P1V-S028A0005</b>
0.280	26	13	210	320	7.8	G3/8	10	3.50	<b>P1V-S028A0003</b>
0.280	14	7	410	615	7.8	G3/8	10	3.50	<b>P1V-S028A0002</b>

\* maximum admissible speed (idling)

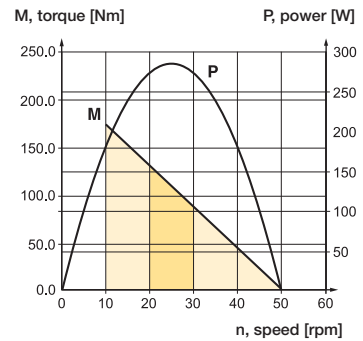
**P1V-S028A0017**



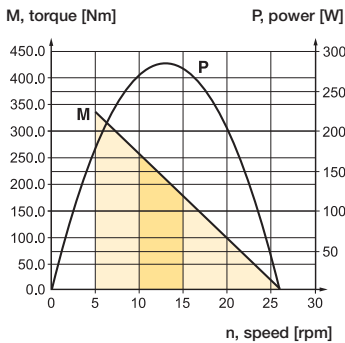
**P1V-S028A0008**



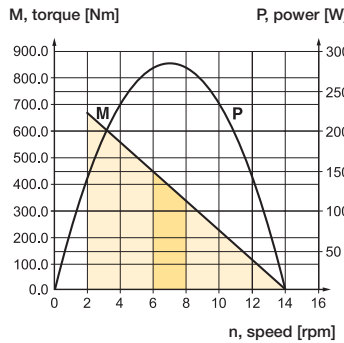
**P1V-S028A00005**





**P1V-S028A00003**



**P1V-S028A00002**



 Possible working range of motor.

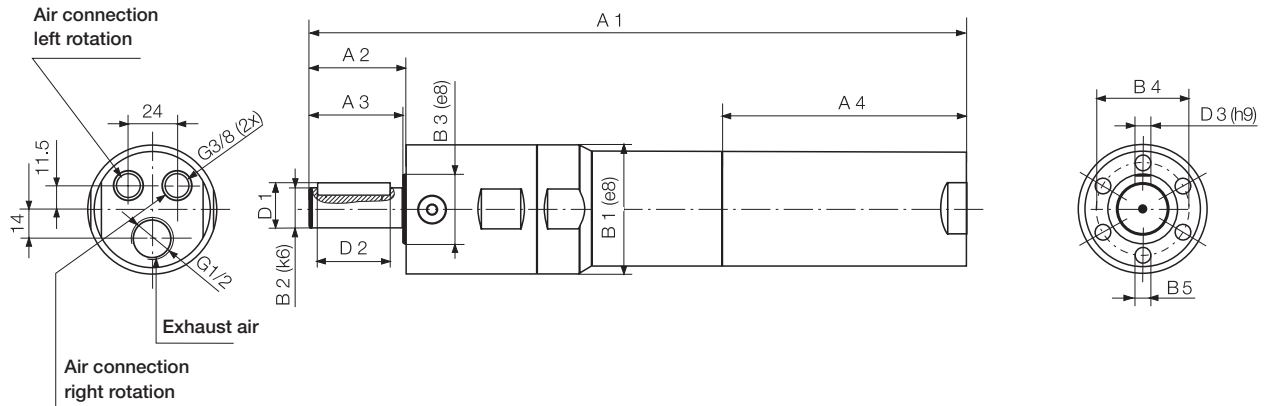
 Optimum working range of motor.

Higher speeds = more vane wear  
Lower speeds with high torque = more gearbox wear



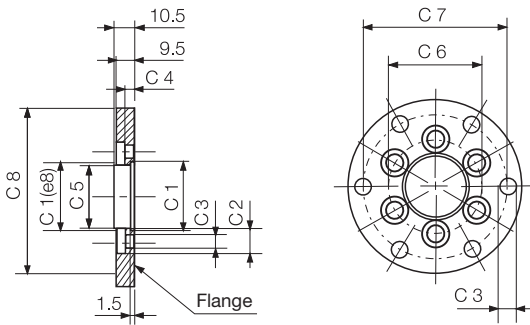
For inventory, lead times, and kit lookup, visit [www.pdnplu.com](http://www.pdnplu.com)

High Torque Motor P1V-S028

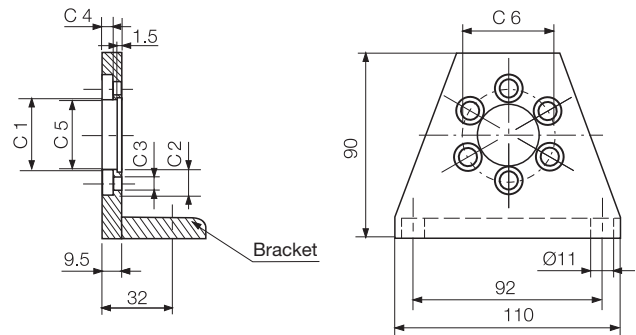


	A1	A2	A3	D1	D2	D3 (h9)	B1 (e8)	B2 (k6)	B3	B4	B5
P1V-S028A0017	254	44	42	21.5	32	A6x6x32 DIN6885	56	19	35	48	M6
P1V-S028A0008	254	44	42	21.5	32	A6x6x32 DIN6885	56	19	35	48	M6
P1V-S028A0005	270	44	42	21.5	32	A6x6x32 DIN6885	56	19	35	48	M6
P1V-S028A0003	270	47	45	27	32	A6x6x32 DIN6885	63	24	34	45	M8
P1V-S028A0002	279	47	45	27	32	A6x6x32 DIN6885	63	24	34	45	M8

Flange  
P1V-S4028B1 & B2



Foot bracket  
P1V-S4028F1 & F2



	C1 (e8)	C2	C3	C4	C5	C6	C7	C8
P1V-S028F1	35	11	6.6	4		48		
P1V-S028F2	34	13	8.4	5		45		
P1V-S028B1	35	11	6.6	4	32	48	70	85
P1V-S028B2	34	13	8.4	5	30	45	79	95

Stainless Steel

Stainless Steel with Brakes

High Torque Stainless Steel

Drilling, Milling & Grinding

Air Motors

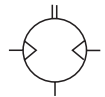


For inventory, lead time, and kit lookup, visit [www.pdnplu.com](http://www.pdnplu.com)

**Specifications – 570 Watts**

**P1V-S Stainless Steel High Torque Type**

The high torque motors of the P1V-S type are small in size but provide extremely high output. Our high torque motors are also less apt to stall. These drive solutions are particularly suitable for use in industrial agitators and mixers as used in the paint industry, food industry or pharmaceutical industry.



**NOTE!** All technical data are based on a working pressure of 6 bar and with oil. For oil-free performances are -10 to 15% lower. Data tolerance accuracy +-10%

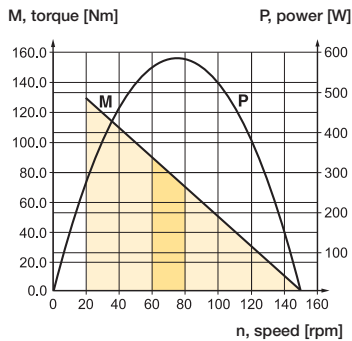
CE Ex II2 GD c IIC T6 (80°C) X

**Reversible air motor with keyed shaft, P1V-S057A series**

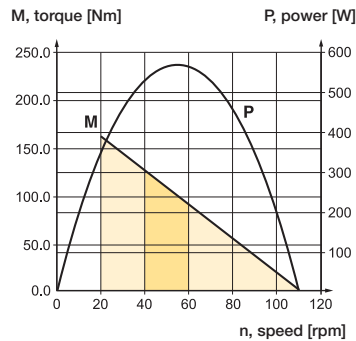
Max power kW	Free speed* rpm	Nominal speed rpm	Nominal torque Nm	Min start torque Nm	Air consumption at max power l/s	Conn.	Min pipe ID mm	Weight Kg	Part number
0.570	150	75	72	108	14.2	G1/2	10	3.60	<b>P1V-S057A0015</b>
0.570	110	55	98	147	14.2	G1/2	10	3.60	<b>P1V-S057A0011</b>
0.570	74	37	150	225	14.2	G1/2	10	3.60	<b>P1V-S057A0007</b>
0.565	40	20	265	400	14.2	G1/2	10	4.40	<b>P1V-S057A0004</b>

\* maximum admissible speed (idling)

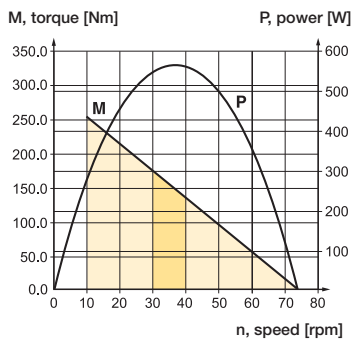
**P1V-S057A0015**



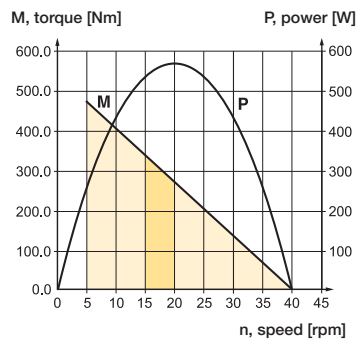
**P1V-S057A0011**



**P1V-S057A0007**



**P1V-S057A0004**



Possible working range of motor.

Optimum working range of motor.

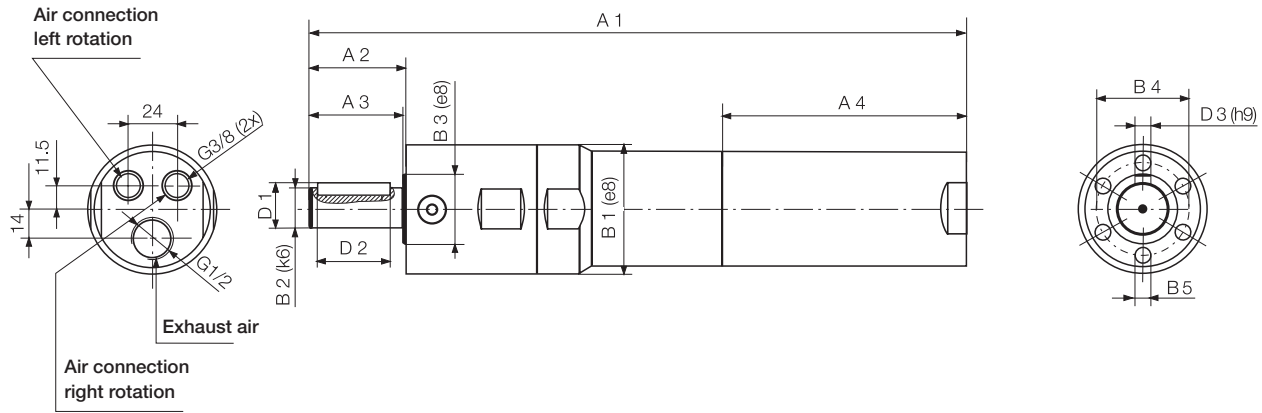
Higher speeds = more vane wear

Lower speeds with high torque = more gearbox wear



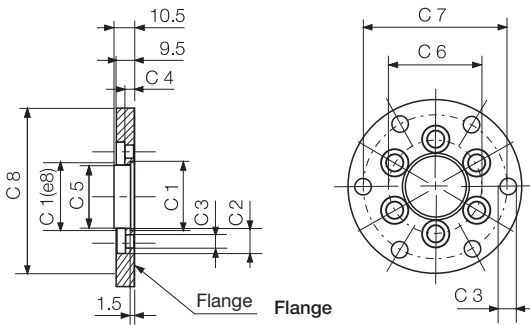
For inventory, lead times, and kit lookup, visit [www.pdnplu.com](http://www.pdnplu.com)

High Torque Motor P1V-S057

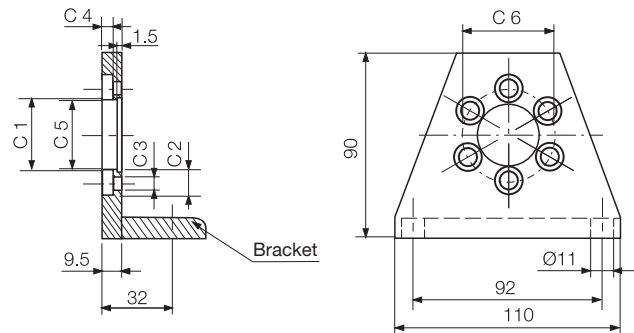


	A1	A2	A3	A4	D1	D3 (h9)	D2	B1 (e8)	B2 (k6)	B3 (e8)	B4	B5
P1V-S057A0015	283.5	44	42	98.5	21.5	A6x6x32 DIN6885	32	56	19	35	48	M6
P1V-S057A0011	283.5	44	42	98.5	21.5	A6x6x32 DIN6885	32	56	19	35	48	M6
P1V-S057A0007	283.5	44	42	98.5	21.5	A6x6x32 DIN6885	32	56	19	35	48	M6
P1V-S057A0004	347	47	45	98.5	27	A6x6x32 DIN6885	32	63	24	34	45	M8

Flange  
P1V-S4028B1 & B2



Foot bracket  
P1V-S4028F1 & F2



	C1 (e8)	C2	C3	C4	C5	C6	C7	C8
P1V-S028F1	35	11	6.6	4		48		
P1V-S028F2	34	13	8.4	5		45		
P1V-S028B1	35	11	6.6	4	32	48	70	85
P1V-S028B2	34	13	8.4	5	30	45	79	95

Stainless Steel

Stainless Steel with Brakes

High Torque Stainless Steel

Drilling, Milling & Grinding

Air Motors

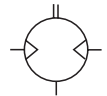


For inventory, lead time, and kit lookup, visit [www.pdnplu.com](http://www.pdnplu.com)

**Specifications – 860 Watts**

**P1V-S Stainless Steel High Torque Type**

The high torque motors of the P1V-S type are small in size but provide extremely high output. Our high torque motors are also less apt to stall. These drive solutions are particularly suitable for use in industrial agitators and mixers as used in the paint industry, food industry or pharmaceutical industry.



**NOTE!** All technical data are based on a working pressure of 6 bar and with oil. For oil-free performances are -10 to 15% lower. Data tolerance accuracy +-10%

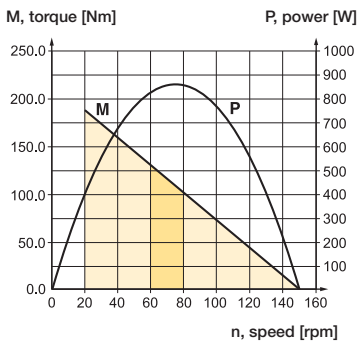
CE II2 GD c IIC T6 (80°C) X

**Reversible air motor with keyed shaft, P1V-S086A series**

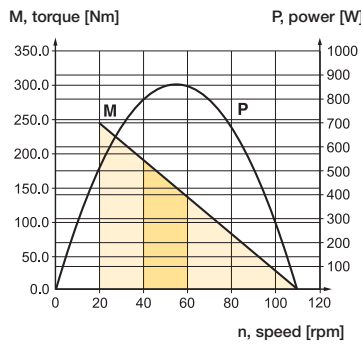
Max power kW	Free speed* rpm	Nominal speed rpm	Nominal torque Nm	Min start torque Nm	Air consumption at max power l/s	Conn.	Min pipe ID mm	Weight Kg	Part number
0.86	150	75	160	110	23.3	G1/2	10	3.80	<b>P1V-S086A0015</b>
0.86	110	55	220	150	23.3	G1/2	10	3.90	<b>P1V-S086A0011</b>
0.86	70	35	335	225	23.3	G1/2	10	3.90	<b>P1V-S086A0007</b>
0.85	40	20	600	400	23.3	G1/2	10	4.70	<b>P1V-S086A0004</b>

\* maximum admissible speed (idling)

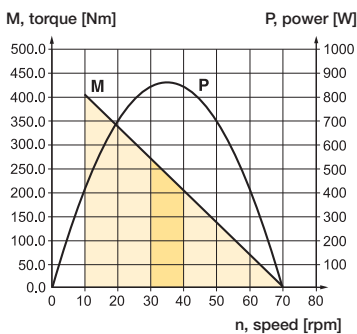
**P1V-S086A0015**



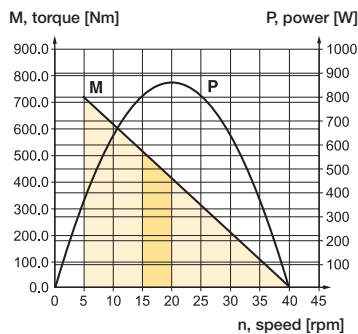
**P1V-S086A0011**



**P1V-S086A0007**



**P1V-S086A0004**



Possible working range of motor.

Optimum working range of motor.

Higher speeds = more vane wear

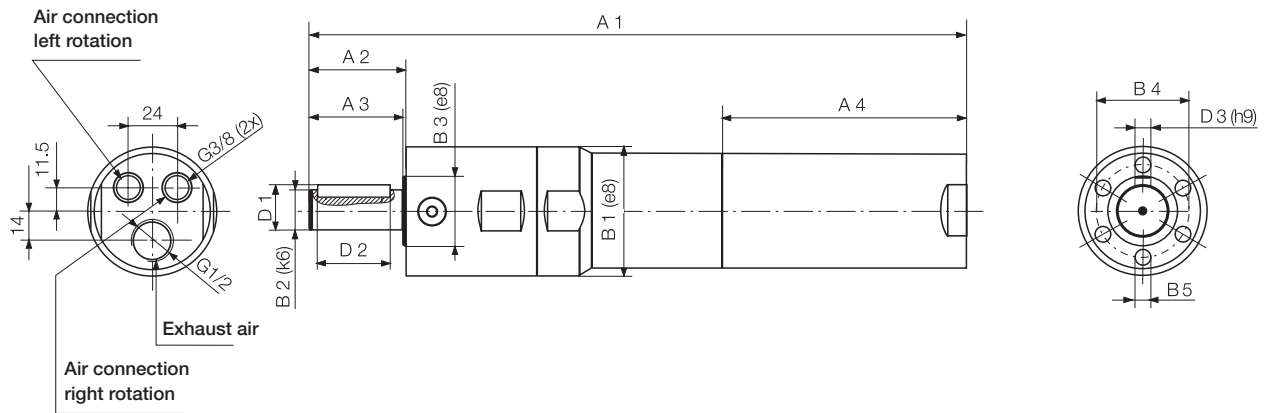
Lower speeds with high torque = more gearbox wear



For inventory, lead times, and kit lookup, visit [www.pdnplu.com](http://www.pdnplu.com)

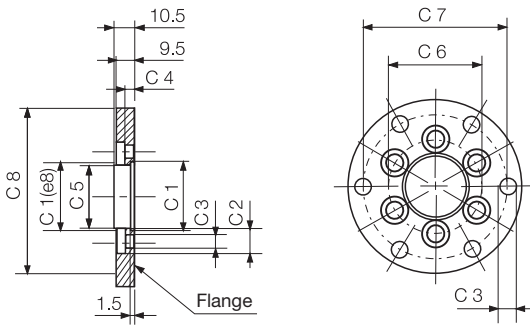


High Torque Motor P1V-S086

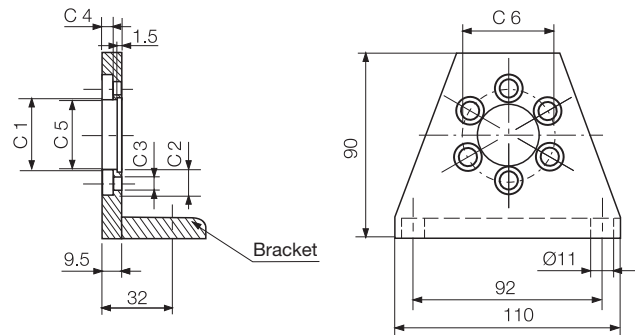


	A1	A2	A3	A4	D1	D3 (h9)	D2	B1 (e8)	B2 (k6)	B3 (e8)	B4	B5
P1V-S086A0015	303.5	44	42	118.5	21.5	A6x6x32 DIN6885	32	56	19	35	48	M6
P1V-S086A0011	303.5	44	42	118.5	21.5	A6x6x32 DIN6885	32	56	19	35	48	M6
P1V-S086A0007	303.5	44	42	118.5	21.5	A6x6x32 DIN6885	32	56	19	35	48	M6
P1V-S086A0004	320	47	45	98.5	27	A6x6x32 DIN6885	32	63	24	34	45	M8

Flange  
P1V-S4028B1 & B2



Foot bracket  
P1V-S4028F1 & F2



	C1 (e8)	C2	C3	C4	C5	C6	C7	C8
P1V-S028F1	35	11	6.6	4		48		
P1V-S028F2	34	13	8.4	5		45		
P1V-S028B1	35	11	6.6	4	32	48	70	85
P1V-S028B2	34	13	8.4	5	30	45	79	95

Stainless Steel

Stainless Steel  
with Brakes

High Torque  
Stainless Steel


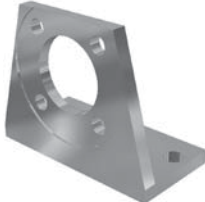
Drilling, Milling &  
Grinding

Air Motors



For inventory, lead time, and kit lookup, visit [www.pdnplu.com](http://www.pdnplu.com)

Mountings for P1V-S air motors

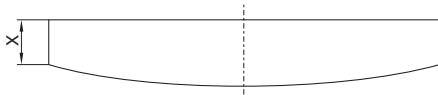
Type	For air motor	Weight Kg	Part number
<b>Flange</b>			
	P1V-S002 & P1V-S003	0.04	P1V-S4002B
	P1V-S008	0.04	P1V-S4008B
	P1V-S012	0.05	P1V-S4012B
	P1V-S020	0.09	P1V-S4020B
	P1V-S028 high torque	0.10	P1V-S4028B1
	P1V-S028 high torque	0.10	P1V-S4028B2
	P1V-S030	0.12	P1V-S4030B
	P1V-S057 high torque	0.30	P1V-S4028B1
	P1V-S057 high torque	0.30	P1V-S4028B2
	P1V-S060 & P1V-S090	0.30	P1V-S4060B
	P1V-S086 high torque	0.30	P1V-S4028B1
	P1V-S086 high torque	0.30	P1V-S4028B2
	P1V-S120	0.60	P1V-S4120B
<b>Foot bracket</b>			
	P1V-S008	0.08	P1V-S4008F
	P1V-S012	0.09	P1V-S4012F
	P1V-S020	0.11	P1V-S4020F
	P1V-S028 high torque	0.11	P1V-S4028F1
	P1V-S028 high torque	0.11	P1V-S4028F2
	P1V-S030A0023	0.55	P1V-S4020C
	P1V-S030A0010	0.55	P1V-S4020C
	P1V-S030	0.11	P1V-S4030F
	P1V-S057 high torque	0.30	P1V-S4028F1
	P1V-S057 high torque	0.30	P1V-S4028F2
	P1V-S060 & P1V-S090	0.30	P1V-S4060F
	P1V-S086 high torque	0.30	P1V-S4028F1
	P1V-S086 high torque	0.30	P1V-S4028F2
P1V-S120	0.80	P1V-S4120F	

All brackets supplied with fastening screws for the motor.

**Lubrication and service life**



The first service is due after approximately 500 hours of operation. After the first service, the service interval is determined by the degree of vane wear\*. The table below shows new dimensions and the minimum dimensions of worn vanes.



**New vanes**

Air motor	Dimensions on new vanes X (mm), type of vanes			
	Standard	Z	C	M
<b>P1V-S002</b>	3.3	-	-	-
<b>P1V-S003</b>	X	-	-	-
<b>P1V-S008</b>	4.3	-	-	-
<b>P1V-S012</b>	4.2	4.2	4.2	4.2
<b>P1V-S020</b>	6.5	6.0	6.0	6.0
<b>P1V-S028</b>	X	X	X	X
<b>P1V-S030</b>	6.8	6.2	6.8	6.2
<b>P1V-S057</b>	X	X	X	X
<b>P1V-S060</b>	9.0	9.0	9.0	9.0
<b>P1V-S086</b>	X	X	X	X
<b>P1V-S090</b>	X	X	X	X
<b>P1V-S120</b>	14.7	14.0	14.0	14.0

**Vaness**

Air motor	Dimensions on vanes X (mm), type of vanes			
	Standard	Z	C	M
<b>P1V-S002</b>	3.0	-	-	-
<b>P1V-S003</b>	X	-	-	-
<b>P1V-S008</b>	4.0	-	-	-
<b>P1V-S012</b>	3.3	3.3	3.3	3.3
<b>P1V-S020</b>	5.8	5.3	5.3	5.3
<b>P1V-S028</b>	X	X	X	X
<b>P1V-S030</b>	6.0	5.2	6.0	5.2
<b>P1V-S057</b>	X	X	X	X
<b>P1V-S060</b>	6.0	6.0	6.0	6.0
<b>P1V-S086</b>	X	X	X	X
<b>P1V-S090</b>	X	X	X	X
<b>P1V-S120</b>	14.2	13.5	13.5	13.5

The following normal service intervals should be applied to in order to guarantee problem-free operation in air motors working continuously at load speeds.

**Intermittent lubrication-free operation of motors with standard vanes, option 0**

Duty cycle : 70%  
 Max. duration of intermittent use : 15 minutes  
 Filtering 40 µm : 750 hours of operation\*  
 Filtering 5 µm : 1,000 hours of operation\*


**Continuous lubricated operation of motors with standard vanes, option 0**

Duty cycle : Continuous  
 Quantity of oil : 1 drop per m<sup>3</sup> of air  
 Filtering 40 µm : 1,000 hours of operation\*  
 Filtering 5 µm : 2,000 hours of operation\*

**Note!** After 1000 hours of operation, the grease in the planetary gearbox must be changed.

**Continuous lubrication-free operation of motors equipped with vanes, option C**

Duty cycle : Continuous  
 Filtering 40 µm : 750 hours of operation\*  
 Filtering 5 µm : 1,000 hours of operation\*



\* The specified hours of operation apply when the motor is running at the speed corresponding to maximum power (load speed).  
 This is approximately half free speed. If the motor operates at higher speeds, the service interval is shorter. If the motor operates at lower speeds, the service interval is longer.



For inventory, lead time, and kit lookup, visit [www.pdnplu.com](http://www.pdnplu.com)

**Service kits**

The following kits are available for the basic motors, consisting of vanes, (springs), silencers, O-rings, seals and 50 g of grease. (USDA-H1 approved)



**Optional function “0” and “D”**

**Service kits, vanes for intermittent lubrication-free operation**

For motors	Part number
P1V-S002A	<b>P1V-6/446083A</b>
P1V-S003A	<b>P1V-6/446083A</b>
P1V-S008A	<b>P1V-6/446084A</b>
P1V-S012A0 / D0 (to serial no 948688)	<b>9121720601</b>
P1V-S012A0 / D0 (from serial no 948689)	<b>9121720636</b>
P1V-S020A• / D•	<b>9121720602</b>
P1V-S030A• / D•	<b>9121720603</b>
P1V-S060A0E00	<b>9121720604</b>
P1V-S060A0400	<b>9121720604</b>
P1V-S060A0350	<b>9121720604</b>
P1V-S060A0270	<b>9121720604</b>
P1V-S060A0170	<b>9121720604</b>
P1V-S060A0072	<b>9121720604</b>
P1V-S060A0063	<b>9121720604</b>
P1V-S060A0048	<b>9121720605</b>
P1V-S060A0030	<b>9121720605</b>
P1V-S060A0015	<b>9121720605</b>
P1V-S060A0010	<b>9121720605</b>
P1V-S090A0C00	<b>P1V-6/444919A</b>
P1V-S090A0350	<b>P1V-6/444919A</b>
P1V-S090A0270	<b>P1V-6/444919A</b>
P1V-S090A0170	<b>P1V-6/444919A</b>
P1V-S090A0063	<b>P1V-6/444919A</b>
P1V-S090A0048	<b>P1V-6/444919B</b>
P1V-S090A0030	<b>P1V-6/444919B</b>
P1V-S120A•800	<b>9121720606</b>
P1V-S120A•270	<b>9121720606</b>
P1V-S120A•110	<b>9121720606</b>
P1V-S120A•078	<b>9121720607</b>
P1V-S120A•032	<b>9121720607</b>
P1V-S120A•012	<b>9121720607</b>

**Optional function “C” and “E”**

**Service kits, vanes for continuous lubrication-free operation**

For motors	Part number
P1V-S012AC / DC (to serial no 948688)	<b>9121720608</b>
P1V-S012AC / DC (from serial no 948689)	<b>9121720637</b>
P1V-S020A• / D•	<b>9121720609</b>
P1V-S030A• / D•	<b>9121720610</b>
P1V-S060ACE00	<b>9121720611</b>
P1V-S060AC400	<b>9121720611</b>
P1V-S060AC350	<b>9121720611</b>
P1V-S060AC270	<b>9121720611</b>
P1V-S060AC170	<b>9121720611</b>
P1V-S060AC072	<b>9121720611</b>
P1V-S060AC063	<b>9121720611</b>
P1V-S060AC048	<b>9121720612</b>
P1V-S060AC030	<b>9121720612</b>
P1V-S060AC015	<b>9121720612</b>
P1V-S060AC010	<b>9121720612</b>
P1V-S090ACC00	<b>On request</b>
P1V-S090AC350	<b>On request</b>
P1V-S090AC270	<b>On request</b>
P1V-S090AC170	<b>On request</b>
P1V-S090AC063	<b>On request</b>
P1V-S090AC048	<b>On request</b>
P1V-S090AC030	<b>On request</b>
P1V-S120A•800	<b>9121720613</b>
P1V-S120A•270	<b>9121720613</b>
P1V-S120A•110	<b>9121720613</b>
P1V-S120A•078	<b>9121720614</b>
P1V-S120A•032	<b>9121720614</b>
P1V-S120A•012	<b>9121720614</b>

• : 0 or D, C or E

**Service kits for high torque motors**

For motors	Part number
P1V-S028A0017	<b>P1V-6/4447861B</b>
P1V-S028A0008	<b>P1V-6/4447861B</b>
P1V-S028A0005	<b>P1V-6/4447861B</b>
P1V-S028A0003	<b>P1V-6/4447861C</b>
P1V-S028A0002	<b>P1V-6/4447861C</b>
P1V-S057A0015	<b>P1V-6/4447871D</b>
P1V-S057A0011	<b>P1V-6/4447871D</b>
P1V-S057A0007	<b>P1V-6/4447871D</b>
P1V-S057A0004	<b>P1V-6/4447871E</b>
P1V-S086A0015	<b>P1V-6/4449191C</b>
P1V-S086A0011	<b>P1V-6/4449191C</b>
P1V-S086A0007	<b>P1V-6/4449191C</b>
P1V-S086A0004	<b>P1V-6/4449191D</b>



For inventory, lead times, and kit lookup, visit [www.pdnplu.com](http://www.pdnplu.com)

**Service kits**

The following kits are available for the basic motors, consisting of vanes, (springs), silencers, O-rings, seals and 50 g of grease. (USDA-H1 approved)



**Optional function “Z” and “F”**

**Service kits, spring-loaded vanes for intermittent lubrication-free operation**

For motors	Part number
P1V-S012AZ / DZ (to serial no 948688)	<b>9121720615</b>
P1V-S012AZ / DZ (from serial no 948689)	<b>9121720638</b>
P1V-S020A• / D•	<b>9121720616</b>
P1V-S030A• / D•	<b>9121720617</b>
P1V-S060AZE00	<b>9121720618</b>
P1V-S060AZ400	<b>9121720618</b>
P1V-S060AZ350	<b>9121720618</b>
P1V-S060AZ270	<b>9121720618</b>
P1V-S060AZ170	<b>9121720618</b>
P1V-S060AZ072	<b>9121720618</b>
P1V-S060AZ048	<b>9121720619</b>
P1V-S060AZ072	<b>9121720619</b>
P1V-S060AZ063	<b>9121720619</b>
P1V-S060AZ010	<b>9121720619</b>
P1V-S090AZC00	<b>On request</b>
P1V-S090AZ350	<b>On request</b>
P1V-S090AZ270	<b>On request</b>
P1V-S090AZ170	<b>On request</b>
P1V-S090AZ063	<b>On request</b>
P1V-S090AZ048	<b>On request</b>
P1V-S090AZ030	<b>On request</b>
P1V-S120A•800	<b>9121720620</b>
P1V-S120A•270	<b>9121720620</b>
P1V-S120A•110	<b>9121720620</b>
P1V-S120A•078	<b>9121720621</b>
P1V-S120A•032	<b>9121720621</b>
P1V-S120A•012	<b>9121720621</b>

• : Z or F, M or G

**Optional function “M” and “G”**

**Service kits, spring-loaded vanes for continuous lubrication-free operation**

For motors	Part number
P1V-S012AM / DM (to serial no 948688)	<b>9121720622</b>
P1V-S012AM / DM (from serial no 948689)	<b>9121720639</b>
P1V-S020A• / D•	<b>9121720623</b>
P1V-S030A• / D•	<b>9121720624</b>
P1V-S060AME00	<b>9121720625</b>
P1V-S060AM400	<b>9121720625</b>
P1V-S060AM270	<b>9121720625</b>
P1V-S060AM170	<b>9121720625</b>
P1V-S060AM072	<b>9121720625</b>
P1V-S060AM048	<b>9121720626</b>
P1V-S060AM030	<b>9121720626</b>
P1V-S060AM010	<b>9121720626</b>
P1V-S090AMC00	<b>On request</b>
P1V-S090AM350	<b>On request</b>
P1V-S090AM270	<b>On request</b>
P1V-S090AM170	<b>On request</b>
P1V-S090AM063	<b>On request</b>
P1V-S090AM048	<b>On request</b>
P1V-S090AM030	<b>On request</b>
P1V-S120A•800	<b>9121720627</b>
P1V-S120A•270	<b>9121720627</b>
P1V-S120A•110	<b>9121720627</b>
P1V-S120A•078	<b>9121720628</b>
P1V-S120A•032	<b>9121720628</b>
P1V-S120A•012	<b>9121720628</b>

**Service kits for brake module for motors with brakes**

For motors	Part number
P1V-S020AD and P1V-S030AD	<b>P1V-6/446096A</b>
P1V-S120AD	<b>P1V-6/4460961B</b>

Comment: To perform a full service on a brake motor, you will need a normal service kit as well as a service kit for the brake module.

Stainless Steel

Stainless Steel with Brakes

High Torque Stainless Steel

Drilling, Milling & Grinding

Air Motors



For inventory, lead time, and kit lookup, visit [www.pdnplu.com](http://www.pdnplu.com)

**Introduction to the ATEX directive**

**Explosive atmospheres**

Directive 94/9/EC defines an explosive atmosphere as a mixture of:

- a) **flammable substances** – gases, vapors, mists or dusts
  - b) with **air**
  - c) under specific **atmospheric conditions**
  - d) in which, after ignition has occurred, combustion spreads to the entire flammable mixture
- (NB: with regard to dust, it may be that not all dust is combusted after ignition has occurred)

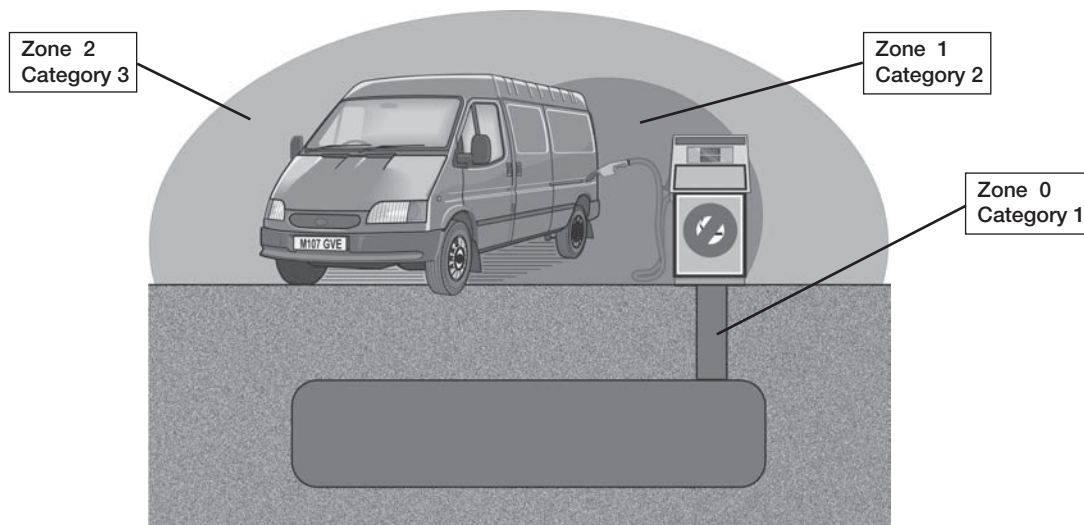
An atmosphere with the potential to become an explosive atmosphere during operating conditions and/or under the influence of the surroundings is defined as a **potentially explosive atmosphere**. Products covered by directive 94/9/EC are defined as intended for use in potentially explosive atmospheres.

**Harmonized European ATEX standard**

The European Union has adopted two harmonized directives in the field of health and safety. The directives are known as ATEX 100a and ATEX 137.

Directive ATEX 100a (94/9/EC) lays down minimum safety requirements for products intended for use in potentially explosive atmospheres in European Union member states. Directive ATEX 137 (99/92/EC) defines minimum requirements for health and safety at the workplace, for working conditions and for the handling of products and materials in potentially explosive atmospheres. This directive also divides the workplace into **zones** and defines criteria by which products are **categorized** within these zones.

The table below describes the **zones** in an installation where there is a potential for explosive atmospheres. The **owner** of the installation must analyze and assess the area in which the explosive gas/dust mixture may occur, and if necessary must divide it into **zones**. This process of zoning then allows the correct plant and equipment to be selected for use in the area.



**Zones**

Gas G	Dust D	Presence of potentially explosive atmosphere	Type of risk
0	20	Present continuously or for long periods	Permanent
1	21	Likely to occur in normal operation occasionally	Potential
2	22	Not likely to occur in normal operation but, if it does occur, will persist for a short period only	Minimal

The ATEX directive has been in force throughout the European Union since 1 July 2003, replacing the existing divergent national and European legislation relating to explosive atmospheres.

Please note that for the first time, the directive covers mechanical, hydraulic and pneumatic equipment and not just electrical equipment as before.

With regard to the **Machinery directive** 98/37/EC, note that a number of external requirements in 94/9/EC refer to hazards

arising from potentially explosive atmospheres, where the Machinery directive only contains general requirements relating to explosion safety (Annex I 1.5.7).

As a result, directive 94/9/EC (ATEX 100a) takes precedence over the Machinery directive with regard to explosion protection in potentially explosive atmospheres. The requirements in the Machinery directive are applicable to all other risks relating to machinery.



For inventory, lead times, and kit lookup, visit [www.pdnplu.com](http://www.pdnplu.com)

**Levels of protection for the various equipment categories**

The various equipment categories must be capable of operating in accordance with the manufacturer's operating specifications at defined levels of protection.

Level of protection	Category		Type of protection	Operating specifications
	Group I	Group II		
Very high	M1		Two independent means of protection or safety, ensuring that the equipment remains functional even in the event of two faults occurring independently of each other	The equipment remains energized and functional even with an explosive atmosphere present
Very high		1	Two independent means of protection or safety, ensuring that the equipment remains functional even in the event of two faults	The equipment remains energized and functional in zones 0, 1, 2 (G) and/or zones 20, 21, 22 (D) occurring independently of each other
High	M2		Protection suitable for normal operation and severe operating conditions	The equipment is de-energized in the event of an explosive atmosphere
High		2	Protection suitable for normal operation and frequent faults, or equipment in which faults normally have to be taken into account	The equipment remains energized and functional in zones 1, 2 (G) and/or zones 21, 22 (D)
Normal		3	Protection suitable for normal operation	The equipment remains energized and functional in zones 2 (G) and/or zones 22 (D)

**Definition of groups (EN 1127-1)**

**Group I** Equipment intended for use in underground parts of mines as well as those parts of surface installations of such mines likely to be endangered by flammable vapors and/or flammable dusts.

**Group II** Equipment intended for use in other places exposed to explosive atmospheres.

Group	I mines, combustible vapors		II other potentially explosive atmospheres (gases, dust)			
	M1	M2	1	2	3	
Category						
Atmosphere*			G	D	G	D
Zone			0	20	1	21
					2	22

G = gas and D = dust

**Temperature classes**

Classification of flammable gases and vapors on the basis of ignition temperature

Temperature class	Ignition temperature °C
T1	Over 450
T2	(300) – 450
T3	(200) – 300
T4	(135) – 200
T5	(100) – 135
T6	(85) - 100

**Declaration of conformity**

The product catalogs contain copies of the declaration of conformity demonstrating that the product meets the requirements of directive 94/9/EC.

The declaration is only valid in conjunction with the instructions contained in the installation manual relating to the safe use of the product throughout its service life.

The instructions relating to the conditions in the surrounding area are particularly important, as the certificate is invalidated if the instructions are found not to have been adhered to during operation of the product.

If there is any doubt as to the validity of the certificate of conformity, contact Parker Hannifin customer service.

**Operation, installation and maintenance**

The installation manual of the product contains instructions relating to the safe storage, handling, operation and servicing of the product.

The manual is available in different languages, and can be downloaded from [www.parker.com/euro\\_pneumatic](http://www.parker.com/euro_pneumatic).

This document must be made accessible in a suitable place near where the product is installed. It is used as a reference for all personnel authorised to work with the product throughout its service life.

We, the manufacturer, reserve the right to modify, extend or improve the installation manual in the interests of the users.

For more information about ATEX see EUs homepage: <http://europa.eu.int/comm/enterprise/atex/>



For inventory, lead time, and kit lookup, visit [www.pdnplu.com](http://www.pdnplu.com)





## Additional safety instructions for installation in explosive atmospheres

**Serious, even fatal, damage or injury may be caused by the hot moving parts of the P1V-S motors in the presence of explosive gas mixtures and concentrations of dust.**

All installation, connection, commissioning, servicing and repair work on P1V-S motors must be carried out by qualified personnel taking account of the following

- These instructions
- Notices on the motor
- All other planning documents, commissioning instructions and connection diagrams associated with the application.
- Provisions and requirements specific to the application
- Applicable national/international regulations (explosion protection, safety and accident prevention)

### Real life applications

P1V-S motors are designed to provide rotary movement in industrial applications, and should only be used in accordance with the instructions in the technical specifications in the catalog, and within the operating range indicated on the motor housing. The motors meet the applicable standards and requirements of the Machinery Directive 94/9/EC (ATEX)

#### The motors must not be used as brakes in explosive atmospheres.

Braking involves driving the motor against the direction of rotation for which the motor is supplied with compressed air. The motor is then operating as a compressor, and there is a corresponding increase in temperature.

The motors must **not** be used underground in mines susceptible to firedamp and/or combustible dust. The motors are intended for use in areas in which explosive atmospheres caused by gases, vapors or mists of combustible liquids, or air/dust mixtures may be expected to occur during normal use (infrequently)

### Checklist

Before using the motors in a potentially explosive atmosphere, you should check the following:

Do the motor specifications match the classification of the area of use in accordance with Directive 94/9/EG (previously ATEX 100a)

- Equipment group
  - Equipment category
  - Zone
  - Temperature class
  - Max. surface temperature
1. When installing the motor, is it certain that there is no potentially explosive atmosphere, oil, acids, gases, vapors or radiation?
  2. Is the ambient temperature as specified in the technical data in the catalog at all times?
  3. Is it certain that the P1V-S motor is adequately ventilated and that no additional heat is added (for example in the shaft connection)?
  4. Are all the driven mechanical components ATEX certified?

### Installation requirements in potentially explosive atmospheres

- The temperature of the supply air must not exceed the ambient temperature.
- The P1V-S may be installed in any position.
- An air treatment unit must be attached to the inlet of the P1V-S air motor.
- In a potentially explosive atmosphere, none of the motor ports may be blocked because this may cause an increase in temperature. The air from the port must be taken to the silencer or, preferably, outside the potentially explosive area.
- The P1V-S motor must be connected to ground at all times, through its support, a metallic tube or separate conductor.
- The outlet of the P1V-S motor must not open within a potentially explosive area, but must be passed to the silencer or, preferably, removed and released outside the potentially explosive area.
- The P1V-S motor may only drive units that are ATEX certified.
- Ensure that the motor is not exposed to forces greater than those permitted in accordance with the catalog.

### Measuring the temperature on the outside of the P1V-S motor (only when used in potentially explosive areas)

During the commissioning process, it is essential to measure temperature increases at the indicated positions on the outside of the P1V-S motor.

These measurements can be taken using standard thermometers.

### Checking the motor during operation

The motor must be kept clean on the outside, and a layer of dirt thicker than 5 mm must never be allowed to form.

Strong solvents should not be used for cleaning, because they can cause the seal (material NBR/FPM) around the drive shaft to swell, potentially increasing the temperature.

Stainless Steel

Stainless Steel  
with BrakesHigh Torque  
Stainless SteelDrilling, Milling &  
Grinding

Air Motors



For inventory, lead times, and kit lookup, visit [www.pdnplu.com](http://www.pdnplu.com)

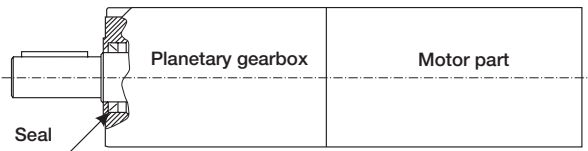
J54

**Parker Hannifin Corporation**  
Pneumatic Division  
Richland, Michigan  
[www.parker.com/pneumatics](http://www.parker.com/pneumatics)

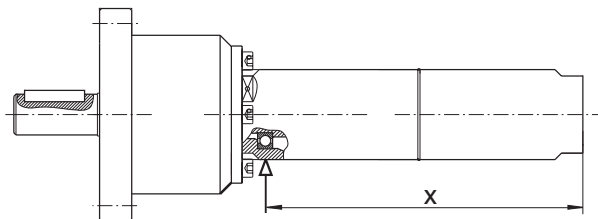


## Technical Data - ATEX

The temperature is measured on the metal surface next to the seal around the output shaft on all P1V-S012, P1V-S020, P1V-S028, P1V-S030, P1V-S057, P1V-S060, P1V-S086 and P1V-S090 motors.



### Motors P1V-S030A0023 and P1V-S030A0010



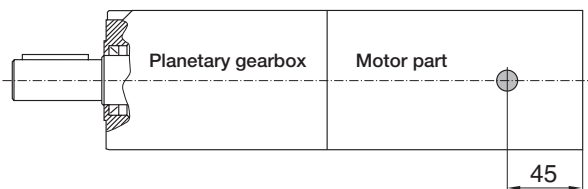
Motor	x [mm]
P1V-S030A0023	146
P1V-S030A0010	147.5

The maximum temperature is reached after approximately 1.5 hours of operation, and the difference in temperature between the motor and the ambient temperature must not exceed 40°C.

**If the temperature difference at the seal of a P1V-S 120 to 900 watts exceeds 40°C, you should stop the motor immediately and contact Parker Hannifin.**

The following applies to the P1V-S120 series:

The temperature is measured on the metal surface at a point 45 mm from the port end of the motor housing, on all P1V-S120.



The maximum temperature is reached after approximately 1.5 hours of operation, and the difference in temperature between the motor and the ambient temperature must not exceed 55°C.

**If the temperature difference at this point on a P1V-S120 exceeds 55°C, you should stop the motor immediately and contact Parker Hannifin.**

## Air Motors

### P1V-S Stainless Steel Motors

#### Marking of products

For all P1V-S 120 to 900 watts

CE Ex II 2 GD c IIC T6 (80 °C) X

For the P1V-S120 1200 watts

CE Ex II 2 GD c IIC T5 (95 °C) X



Communauté Européenne = EU  
CE marking shows that as a manufacturer, Parker Hannifin meets the guidelines specified by the EU



Ex means that this product is intended for use in a potentially explosive area

II

stands for the equipment group (I = mines and II = other places liable to be endangered)

2GD

stands for equipment category 2G means the equipment can be used in zones 1 and 2 where there is a risk involving gas, vapor or mist of combustible liquids and 2D in zones 21 and 22 where there is a risk involving dust. 2GD means the equipment can be used in zones 1, 2, 21 and 22.

c

Safe design (prEN 13463-5)

IIC

Explosion group, P1V-S air motors are tested to the highest standards in terms of test gases, and can be installed in the presence of all gases without restriction.

T6

If equipment is in temperature class T6, the maximum surface temperature must not exceed 85°C. (To guarantee this, the product has been tested to ensure that the maximum is 80°C. This provides a safety margin of 5 °K.)

T5

If equipment is in temperature class T5, the maximum surface temperature must not exceed 100 °C. (To guarantee this, the product has been tested to ensure that the maximum is 95°C. This provides a safety margin of 5 °K.)

(80°C)

Maximum permitted surface temperature on the motor in atmospheres containing potentially explosive dust.

X

Note special conditions

Test certificate number IBExU04ATEXB004 X from IBExU Institut für Sicherheitstechnik GmbH, D-09599 Freiberg, Germany

Stainless Steel

Stainless Steel with Brakes

High Torque Stainless Steel

Drilling, Milling & Grinding

Air Motors

Stainless Steel  
Stainless Steel with Brakes  
High Torque Stainless Steel  
Drilling, Milling & Grinding  
Air Motors

**P1V-S Declaration of Conformity** acc. ATEX 94/9/EC  
**P1V-S Declaration of Incorporation** acc. EC  
Machinery Directive 2006/42/EC



We Parker Hannifin Manufacturing  
Germany GmbH & Co. KG  
Pneumatic Division Europe  
Industriestrasse 8  
70794 Filderstadt Germany

Declare that the following Air Motors have been assessed in accordance with ATEX 94/9/EC (Products for use in potentially explosive atmospheres). Air Motors **P1V-S012, P1V-S020, P1V-S028, P1V-S030, P1V-S057, P1V-S060, P1V-S086** and **P1V-S090** range are compatible for the use in explosive atmosphere **Ex II 2 GD c T6 (T80°C) X**. Air Motors **P1V-S120** range are compatible for the use in explosive atmosphere **Ex II 2 GD c T5 (T95°C) X**.  
**All without brake option.**

P1V-S is designed for utilization in applications falling under the scope of the ATEX 94/9/EC. These products are designed and manufactured in compliance with following elements:

- **EN 1127-1:2007** Explosive atmospheres – Explosion prevention and protection – Part 1: Basic concepts and methodology
- **EN 13463-1:2009** Non electrical equipment for use in potentially explosive atmospheres – Part 1: Basic method and requirements
- **EN 13463-5** Non-electrical equipment intended for use in potentially explosive atmospheres – Part 5: Protection by constructional safety 'c'
- **EN 983+A1:2008** Safety of machinery – Safety requirements for fluid power systems and their components - Pneumatics

As manufacturer of the partly completed machine we declare that:

- The specified Air motor corresponds to the listed essential requirements of the EC Machinery Directive 2006/42/EC
- The relevant technical documentation is complied in accordance with part B of Annex VII
- The relevant technical documentation in accordance with part B of Annex VII will be transmitted in response to a reasonable request by the national authorities

Product: Air motors P1V-S

Directives	Date	Applied and fulfilled essential requirements
2006/42/EC	2006-06	1.1.2, 1.1.5, 1.3.4, 1.5.3, 1.7.3, 1.7.4
Standards	Date	Remark
DIN EN ISO 12100	2011-03	Partly fulfilled

This partly completed machinery must not be put into service until the final machinery into which it is to be incorporated has been declared in conformity with the provisions of the Directive 2006/42/EG, were appropriated.



**Additional Information**  
This coverage could only be referred to as long as operations needed for final assembling and starting up of these products comply with standards relating to the above mentioned directive. Each time this will be required for compliance purpose, the user will have to apply for a complete coverage of the final assembled system according to the above mentioned directive and relating standards

Filderstadt, Germany June 2014

Ing. Franck Roussillon  
European Product Manager  
Actuators Business Unit, Pneumatic Division Europe



## Air Tools to use in Robots and Automated Machines

- Drilling type 80 to 600 Watts
- Grinding type 90 to 300 Watts
- Milling type 400 to 1000 Watts

### Introduction

A large number of drilling motors, milling motors and grinding motors have been developed using the P1V-S as the base motor in order to make it easier to install air motors in machining applications. These motors are all equipped with standard vanes for intermittent lubrication-free operation, although it is recommended to use oil mist if you are planning to operate them for extended periods.

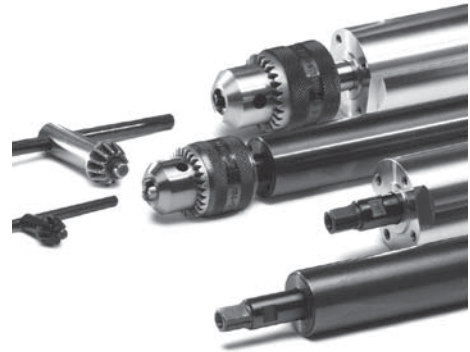
**NOTE!** These motors are not made of 100% stainless steel.

Drilling motors are available with power ratings of 80, 170, 250, 400 and 600 Watts, and several different speeds for the machining of a range of materials. They can be fitted with collet chucks, drill chucks and quick-release chucks. Many of them also have accessories allowing the exhaust air to be removed.

The milling motor, with a power rating of 400 Watts, runs at a relatively high speed, and is fitted with a collet chuck for a shaft diameter of 8 mm. It is equipped with strong bearings able to handle greater shear forces on the spindle.

The grinding motor, with a power rating of 200 Watts, is fitted with a collet chuck for a shaft diameter of 8 mm and runs at a relatively high speed. It is equipped with strong bearings able to handle greater shear forces on the spindle.

The design principle of the 90 Watt grinding motor is different from the others. The turbine principle means that high speeds are possible without the need for lubrication.



### Feed movement in drilling, milling and grinding motors

A slow and even feed movement is necessary in machining applications. During drilling, the feed must not uncontrollably speed up once the drill breaks through the material. One good way of solving the problem is to use a pneumatic cylinder for the feed, which is able to provide force during drilling and a rapid approach before the actual drilling phase. Feed during the drilling phase is controlled using a hydraulic brake cylinder (HYDROCHECK) fitted in parallel with the pneumatic cylinder. This provides even, slow and safe feed movement, without the risk of the uncontrolled feed described above.

### Order key

(This model code can not be used for creating new part numbers. All possible combinations between motor size, function and free speed are in the next pages).

<b>P1V-S</b>	<b>017</b>	<b>N</b>	<b>0</b>	<b>Q00</b>																																										
<table border="1"> <tr><th colspan="2">Air motor range</th></tr> <tr><td>P1V-S</td><td>Drilling, milling and grinding air motor</td></tr> </table>	Air motor range		P1V-S	Drilling, milling and grinding air motor	<table border="1"> <tr><th colspan="2">Motor size</th></tr> <tr><td>008</td><td>80 W</td></tr> <tr><td>009</td><td>90 W</td></tr> <tr><td>017</td><td>170 W</td></tr> <tr><td>025</td><td>250 W</td></tr> <tr><td>030</td><td>300 W</td></tr> <tr><td>040</td><td>400 W</td></tr> <tr><td>050</td><td>500 W</td></tr> <tr><td>060</td><td>600 W</td></tr> <tr><td>070</td><td>700 W</td></tr> <tr><td>100</td><td>1000 W</td></tr> </table>	Motor size		008	80 W	009	90 W	017	170 W	025	250 W	030	300 W	040	400 W	050	500 W	060	600 W	070	700 W	100	1000 W	<table border="1"> <tr><th colspan="2">Function</th></tr> <tr><td>M</td><td>For drill chuck</td></tr> <tr><td>N</td><td>With collet</td></tr> </table>	Function		M	For drill chuck	N	With collet		<table border="1"> <tr><th colspan="2">Free speed per min</th></tr> <tr><td>035</td><td>350</td></tr> <tr><td>999</td><td>9990</td></tr> <tr><td>A00</td><td>10000</td></tr> <tr><td>A000</td><td>100000</td></tr> </table>	Free speed per min		035	350	999	9990	A00	10000	A000	100000
Air motor range																																														
P1V-S	Drilling, milling and grinding air motor																																													
Motor size																																														
008	80 W																																													
009	90 W																																													
017	170 W																																													
025	250 W																																													
030	300 W																																													
040	400 W																																													
050	500 W																																													
060	600 W																																													
070	700 W																																													
100	1000 W																																													
Function																																														
M	For drill chuck																																													
N	With collet																																													
Free speed per min																																														
035	350																																													
999	9990																																													
A00	10000																																													
A000	100000																																													



For inventory, lead time, and kit lookup, visit [www.pdnplu.com](http://www.pdnplu.com)

Stainless Steel

Stainless Steel with Brakes

High Torque Stainless Steel

Drilling, Milling & Grinding

Air Motors



**Technical Data**

**P1V-S Air Tools - Drilling, Grinding, Milling**

All air motors are non reversible, right rotation only

Stainless Steel	Air motor size	P1V-S008	P1V-S017	P1V-S025	P1V-S040	P1V-S060	P1V-S009*	P1V-S015	P1V-S025	P1V-S030	P1V-S040	P1V-S050	P1V-S070	P1V-S100
	Air motor type	Drilling					Grinding				Milling			
	Nominal power (watts)	80	170	250	400	600	90	150	250	300	400	500	700	1000
	Working pressure (bar)	3 to 7												
	Working temperature (°C)	-20 to +110												
	Ambient temperature (°C)	-20 to +110												
Stainless Steel with Brakes	Air flow required (NI/min)	230	300	350	420	850	120	300	350	380	420	700	900	1100
	Min pipe ID, inlet (mm)	4	6	6	10	12	4	6	6	6	10	10	10	10
	Min pipe ID, outlet (mm)	4	6	6	10	12	4	6	6	6	10	10	10	10
High Torque Stainless Steel	<b>Choice of treatment unit: recommended min air flow (l/min) at p1 7.5 bar and 0.8 bar pressure drop</b>													
		260	340	400	500	950	140	340	400	440	500	800	1020	1250
	<b>Choice of valve: recommended min nominal air flow (l/min) at p1 6 bar and 1 bar pressure drop</b>													
		290	380	450	580	1050	160	380	450	510	580	900	1140	1400
Drilling, Milling & Grinding	Medium	40 µm filtered, oil mist or dry unlubricated compressed air												
	Oil free operation, indoor	ISO8573-1 purity class 3.4.1												
	Oil free operation, outdoor	ISO8573-1 purity class 1.2.1												
	Oil operation	1-2 drop per cube meter, ISO8573-1 purity class 3.-.5												
	Recommended oil	Foodstuffs industry Klüber oil 4 UH1- 32 N												
	Sound level free outlet (dB(A))	-	-	-	-	-	-	-	-	-	-	-	-	-
	With outlet silencer (dB(A))	85	74	76	75	94	72	85	76	-	75	-	-	-
	Exhaust air removed with pipes to another room	71	70	71	73	76	-	73	71	79	73	79	79	80

**Note:** Sound levels are measured at free speed with the measuring instrument positioned 1 meter away from the air motor at an height of 1 meter.

\* Unlubricated for grinding air motor P1V-S009.

**Table and diagram data**

All technical data are based on a working pressure of 6 bar and with oil. Oil-free performances are -10 to 15% lower. Data tolerance accuracy +-10%

**Material specification**

Air motor size	P1V-S008	P1V-S017	P1V-S025	P1V-S040	P1V-S060	P1V-S009*	P1V-S015	P1V-S025	P1V-S030	P1V-S040	P1V-S050	P1V-S070	P1V-S100
Air motor type	Drilling					Grinding				Milling			
Housing	Stainless steel X12Cr13	High grade steel (not stainless)		Stainless steel X12Cr13			High grade steel (not stainless)				Stainless steel X12Cr13		
Shaft, collet	Hardened steel (not stainless)												
Shaft for drill chuck	Hardened and tempered steel (not stainless)												
Collet	Hardened and tempered steel (not stainless)												
All internal parts	High grade steel (not stainless)												
Accessories	Surface treated steel, plastic and aluminium												

**Accessories P1V Drilling air motors**

Flange bracket	Stainless steel
Foot bracket	Stainless steel
Screws for the mountings	Stainless steel DIN A2



For inventory, lead times, and kit lookup, visit [www.pdnplu.com](http://www.pdnplu.com)

Permitted shaft loadings

Drilling, milling and grinding motors

Max. permitted load on output shaft for motors (based on 10 000 000 rpm at input shaft with 90 % probable service life for ball bearings).

Drilling motors with collet

Part number	Fax [N]	Frad [N]	a [mm]
P1V-S008N0***	200	75	25
P1V-S017N0***	380	50	25
P1V-S025N0***	750	220	25

Grinding motors with collet

Part number	Fax [N]	Frad [N]	a [mm]
P1V-S009N0A000	15	30	25
P1V-S015N0AQ0	15	30	25
P1V-S025N0Z00	25	50	25
P1V-S030N0***	20	40	25

Milling motors with collet

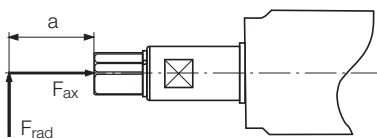
Part number	Fax [N]	Frad [N]	a [mm]
P1V-S040N0L00	750	150	25
P1V-S050N0L00	25	50	25
P1V-S070N0N00	40	90	25
P1V-S100N0F30	55	120	25

Frad = Radial loading (N)  
 Fax = Axial loading (N)  
 a = distance from shaft's end (mm)

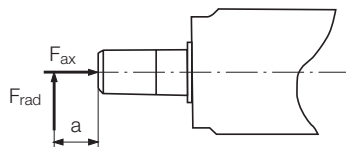
Drilling motors for drill chuck

Part number	Fax [N]	Frad [N]	a [mm]
P1V-S017M0***	380	35	60
P1V-S025M0***	750	150	70
P1V-S040M0***	750	150	70
P1V-S060M0350	1100	150	80
P1V-S060M0270	1100	150	80
P1V-S060M0170	1100	150	80
P1V-S060M0063	1100	265	80
P1V-S060M0048	1100	265	80
P1V-S060M0030	1100	265	80
P1V-S060M0015	1100	150	80

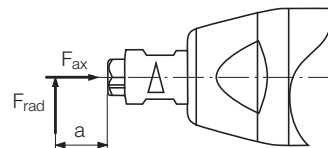
Collet



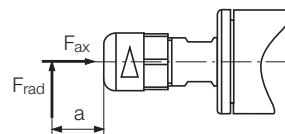
Drill chuck



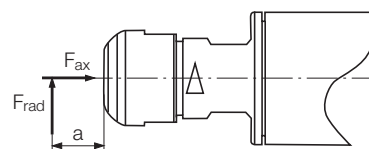
Collet



Collet



Collet



Load on output shaft for drilling, milling and grinding motors.



For inventory, lead time, and kit lookup, visit [www.pdnplu.com](http://www.pdnplu.com)



**Specifications – 80 Watts**

**Drilling motor with collet P1V-S008N**

Our smallest and most versatile drilling motor for small-scale drilling operations.

The standard collet chuck is for 3 mm shaft diameter. For other diameters, select a different collet chuck as an accessory.

The motor has a port for a 6 mm hose to remove the exhaust air to a silencer.



**NOTE!** All technical data are based on a working pressure of 6 bar and with oil. For oil-free performances are -10 to 15% lower. Data tolerance accuracy +-10%

**Drilling motor with collet P1V-S008N**

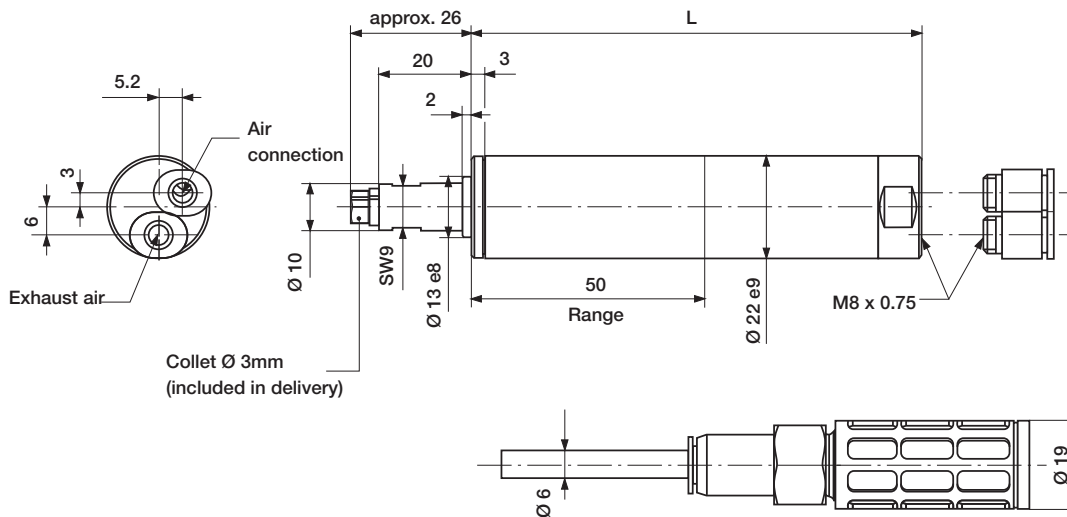
Max power kW	Free speed rpm	Version	Drilling in steel mm	Drilling in aluminium mm	Air consumption at max power l/s	Conn.*	Min pipe ID mm	Weight Kg	Part number
0.080	22,000	Collet 3 mm	-	3	3.8	M8 x 0.75*	4	0.20	<b>P1V-S008N0N00</b>
0.080	6000	Collet 3 mm	3	3	3.8	M8 x 0.75*	4	0.20	<b>P1V-S008N0600</b>
0.080	1900	Collet 3 mm	3	3	3.8	M8 x 0.75*	4	0.22	<b>P1V-S008N0190</b>
0.080	1300	Collet 3 mm	3	3	3.8	M8 x 0.75*	4	0.22	<b>P1V-S008N0130</b>

\* 2 push in nipples for plastic pipe Ø6/4 supplied

**Accessories**

Type	Part number
Collet Ø2 mm	<b>P1V-6/314693</b>
Collet Ø3 mm	<b>Included with the motor</b>
Collet Ø3/32"	<b>P1V-6/314694</b>
Collet Ø1/8"	<b>P1V-6/314407</b>

**Dimensions – Drilling motor with collet P1V-S008N**



	A	B
P1V-S008N0N00, P1V-S008N0600	98	96
P1V-S008N0190, P1V-S008N0130	107	105



For inventory, lead times, and kit lookup, visit [www.pdnplu.com](http://www.pdnplu.com)

**Drilling motor with collet P1V-S017N**

A small drilling motor for small-scale, lighter drilling operations.

The standard collet chuck is for 6 mm shaft diameter. For other diameters, select a different collet chuck as an accessory.

The motor has a built-in silencer for exhaust air. If lower noise levels are required, or if you want the exhaust air to be collected, the relevant accessories are available.



**NOTE!** All technical data are based on a working pressure of 6 bar and with oil. For oil-free performances are -10 to 15% lower. Data tolerance accuracy +-10%

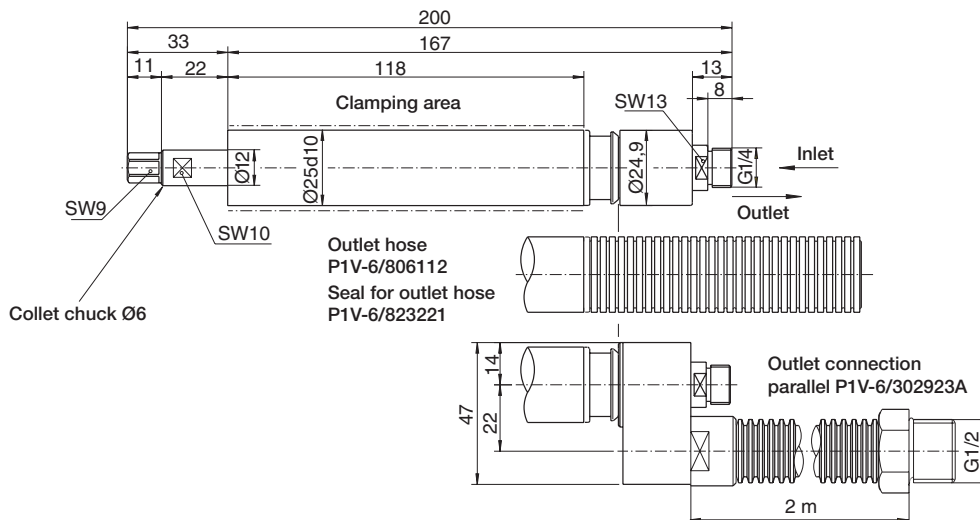
**Drilling motor with collet P1V-S017N**

Max power kW	Free speed rpm	Version	Drilling in steel mm	Drilling in aluminium mm	Air consumption at max power l/s	Conn.	Min pipe ID mm	Weight Kg	Part number
0.17	2,4000	Collet 6 mm	-	4	5.0	G1/4o	6	0.38	<b>P1V-S017N0Q00</b>
0.17	6,000	Collet 6 mm	3	5	5.0	G1/4o	6	0.38	<b>P1V-S017N0600</b>
0.17	4,000	Collet 6 mm	4	6	5.0	G1/4o	6	0.38	<b>P1V-S017N0400</b>
0.17	1,500	Collet 6 mm	4	6	5.0	G1/4o	6	0.43	<b>P1V-S017N0150</b>
0.17	1,000	Collet 6 mm	4	6	5.0	G1/4o	6	0.43	<b>P1V-S017N0100</b>
0.17	660	Collet 6 mm	4	6	5.0	G1/4o	6	0.43	<b>P1V-S017N0066</b>

**Accessories**

Type	Part number
Collet Ø3 mm	<b>P1V-6/312681</b>
Collet Ø4 mm	<b>P1V-6/312684</b>
Collet Ø5 mm	<b>P1V-6/312686</b>
Collet Ø6 mm	<b>Included with the motor</b>
Collet Ø1/8"	<b>P1V-6/312682</b>
Collet Ø1/4"	<b>P1V-6/312689</b>
Outlet hose	<b>P1V-6/806112</b>
Seal for outlet hose	<b>P1V-6/823221</b>
Outlet connection parallel	<b>P1V-6/302923A</b>

**Dimensions – Drilling motor with collet P1V-S017N**



For inventory, lead time, and kit lookup, visit [www.pdnplu.com](http://www.pdnplu.com)



**Specifications – 170 Watts**

**Drilling motor for drill chuck P1V-S017M**

A small drilling motor for small-scale, lighter drilling operations.

Select drill chucks as accessories.

The motor has a built-in silencer for exhaust air. If lower noise levels are required, or if you want the exhaust air to be collected, the relevant accessories are available.



**NOTE!** All technical data are based on a working pressure of 6 bar and with oil. For oil-free performances are -10 to 15% lower. Data tolerance accuracy +-10%

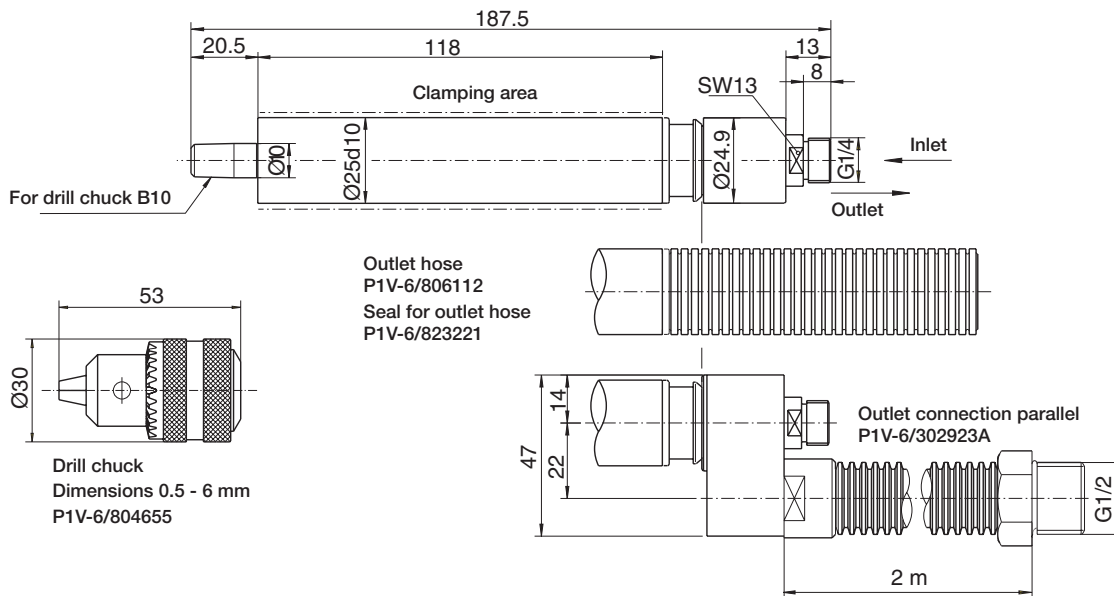
**Drilling motor with collet P1V-S017M**

Max power kW	Free speed rpm	Version	Drilling in steel mm	Drilling in aluminium mm	Air consumption at max power l/s	Conn.	Min pipe ID mm	Weight Kg	Part number
0.17	6,000	For drill chuck B10	3	5	5.0	G1/4o	6	0.38	<b>P1V-S017M0600</b>
0.17	4,000	For drill chuck B10	4	6	5.0	G1/4o	6	0.38	<b>P1V-S017M0400</b>
0.17	1,500	For drill chuck B10	4	6	5.0	G1/4o	6	0.43	<b>P1V-S017M0150</b>
0.17	1,000	For drill chuck B10	4	6	5.0	G1/4o	6	0.43	<b>P1V-S017M0100</b>
0.17	660	For drill chuck B10	4	6	5.0	G1/4o	6	0.43	<b>P1V-S017M0066</b>

**Accessories**

Type	Part number
Diameters 0.5 – 6 mm/B10	<b>P1V-6/804655</b>
Outlet hose	<b>P1V-6/806112</b>
Seal for outlet hose	<b>P1V-6/823221</b>
Outlet connection parallel	<b>P1V-6/302923A</b>

**Dimensions – Drilling motor for drill chuck P1V-S017M**



For inventory, lead times, and kit lookup, visit [www.pdnplu.com](http://www.pdnplu.com)



**Drilling motor with collet P1V-S025N**

A small drilling motor for moderately heavy drilling operations.

The standard collet chuck is for 6 mm shaft diameter.

For other diameters, select a different collet chuck as an accessory.

The motor has a built-in silencer for exhaust air. If lower noise levels are required, or if you want the exhaust air to be collected, the relevant accessories are available.



**NOTE!** All technical data are based on a working pressure of 6 bar and with oil.  
For oil-free performances are -10 to 15% lower. Data tolerance accuracy +-10%

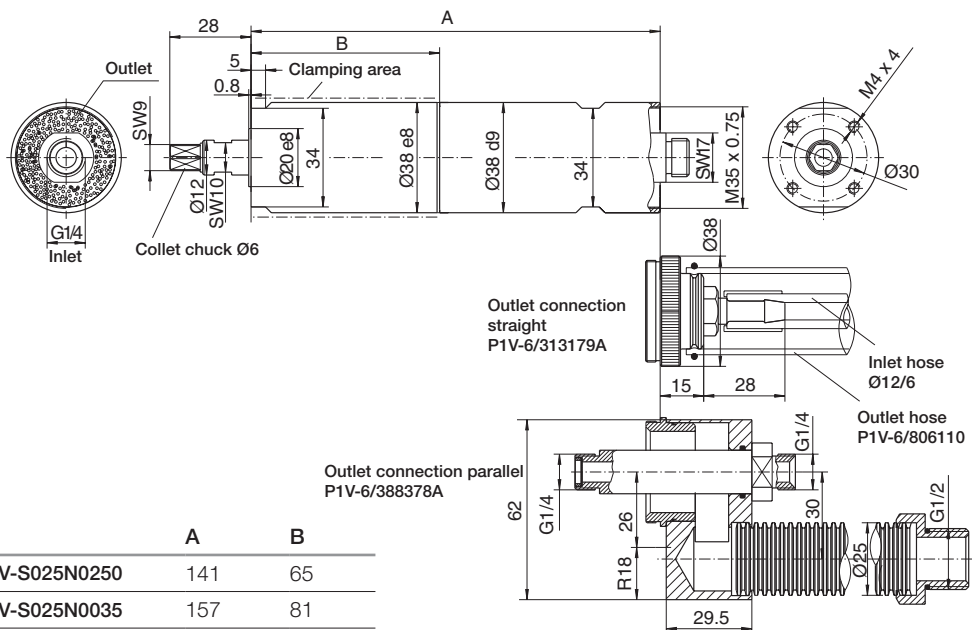
**Drilling motor with collet P1V-S017M**

Max power kW	Free speed rpm	Version	Drilling in steel mm	Drilling in aluminium mm	Air consumption at max power l/s	Conn.	Min pipe ID mm	Weight Kg	Part number
0.25	17,000	Collet 6 mm	-	6	6.3	G1/4o	6	0.80	<b>P1V-S025N0H00</b>
0.25	4,800	Collet 6 mm	4	6	6.3	G1/4o	6	0.80	<b>P1V-S025N0480</b>
0.25	2,500	Collet 6 mm	6	6	6.3	G1/4o	6	0.80	<b>P1V-S025N0250</b>
0.25	1,400	Collet 6 mm	6	6	6.3	G1/4o	6	0.90	<b>P1V-S025N0140</b>
0.25	700	Collet 6 mm	6	-	6.3	G1/4o	6	0.90	<b>P1V-S025N0070</b>
0.25	350	Collet 6 mm	6	-	6.3	G1/4o	6	0.90	<b>P1V-S025N0035</b>

**Accessories**

Type	Part number
Collet Ø3 mm	<b>P1V-6/312681</b>
Collet Ø4 mm	<b>P1V-6/312684</b>
Collet Ø5 mm	<b>P1V-6/312686</b>
Collet Ø6 mm	<b>Included with the motor</b>
Collet Ø1/8"	<b>P1V-6/312682</b>
Collet Ø1/4"	<b>P1V-6/312689</b>
Outlet connection straight	<b>P1V-6/3131179A</b>
Outlet hose Ø23 x 28 mm 0.75 m long	<b>P1V-6/806110</b>
Outlet connection parallel	<b>P1V-6/388378A</b>

**Dimensions – Drilling motor with collet P1V-S025N**



For inventory, lead time, and kit lookup, visit [www.pdnplu.com](http://www.pdnplu.com)

Stainless Steel

Stainless Steel with Brakes

High Torque Stainless Steel

Drilling, Milling & Grinding

Air Motors

Specifications – 250 Watts

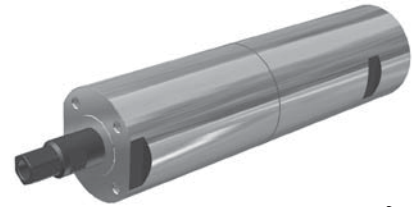
Drilling motor for drill chuck P1V-S025M

A small drilling motor for moderately heavy drilling operations.

The standard collet chuck is for 6 mm shaft diameter.

For other diameters, select a different collet chuck as an accessory.

The motor has a built-in silencer for exhaust air. If lower noise levels are required, or if you want the exhaust air to be collected, the relevant accessories are available.



**NOTE!** All technical data are based on a working pressure of 6 bar and with oil.  
For oil-free performances are -10 to 15% lower. Data tolerance accuracy +-10%

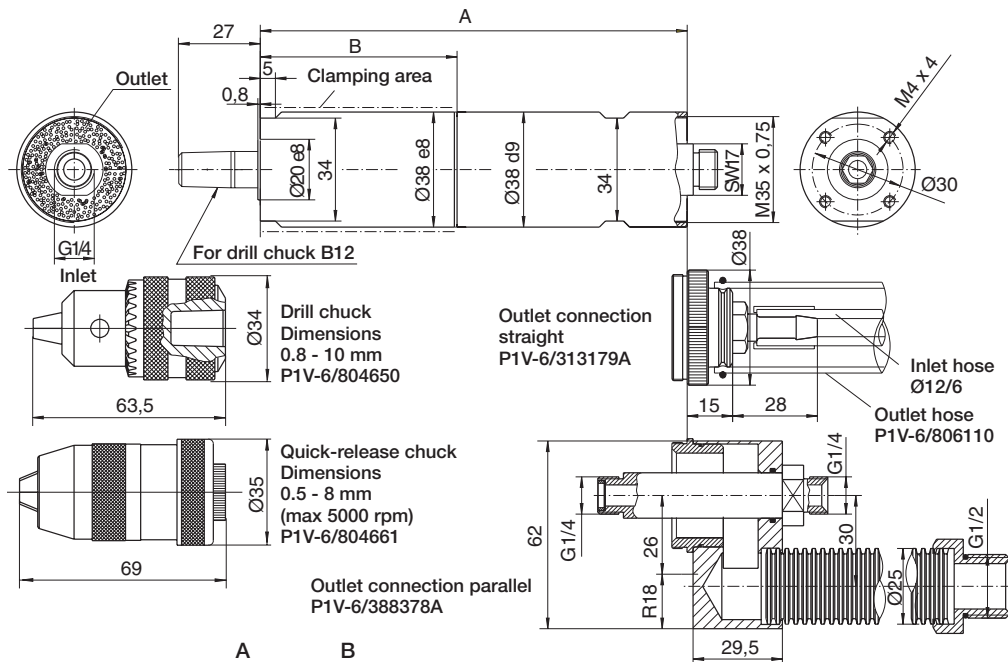
Drilling motor for drill chuck P1V-S025M

Max power kW	Free speed rpm	Version	Drilling in steel mm	Drilling in aluminium mm	Air consumption at max power l/s	Conn.	Min pipe ID mm	Weight Kg	Part number
0.25	17,000	For drill chuck B12	-	6	6.3	G1/4o	6	0.80	P1V-S025M0H00
0.25	4,800	For drill chuck B12	4	6	6.3	G1/4o	6	0.80	P1V-S025M0480
0.25	2,500	For drill chuck B12	6	8	6.3	G1/4o	6	0.80	P1V-S025M0250
0.25	1,400	For drill chuck B12	8	10	6.3	G1/4o	6	0.80	P1V-S025M0140
0.25	700	For drill chuck B12	10	-	6.3	G1/4o	6	0.80	P1V-S025M0070
0.25	350	For drill chuck B12	10	-	6.3	G1/4o	6	0.80	P1V-S025M0035

Accessories

Type	Part number
Standard drill chuck, diameters 0.8 - 10 mm/B12	P1V-6/804650
Quick release chuck, diameters 0.5 - 8 mm/B12	P1V-6/804661
Outlet connection straight	P1V-6/3131179A
Collet Ø1/4"	P1V-6/312689
Outlet hose Ø23 x 28 mm 0.75 m long	P1V-6/806110
Outlet connection parallel	P1V-6/388378A

Dimensions – Drilling motor for drill chuck P1V-S025M



	A	B
P1V-S025M0H00, P1V-S025M0480, P1V-S025M0250	141	65
P1V-S025M0140, P1V-S025M0070, P1V-S025M0035	157	81



For inventory, lead times, and kit lookup, visit [www.pdnplu.com](http://www.pdnplu.com)

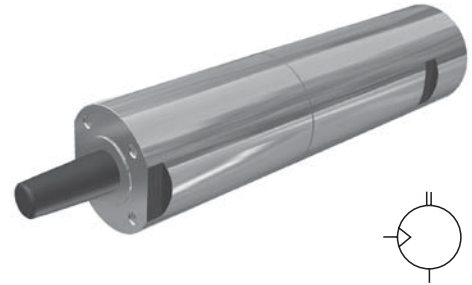
**Drilling motor for drill chuck P1V-S040M**

Our large drilling motor is used for small-scale heavy drilling operations requiring considerable feed force.

Select drill chucks or quick-release chucks as accessories as necessary.

The motor has a built-in silencer for exhaust air. If lower noise levels are required, or if you want the exhaust air to be collected, the relevant accessories are available.

**NOTE!** All technical data are based on a working pressure of 6 bar and with oil. For oil-free performances are -10 to 15% lower. Data tolerance accuracy +-10%



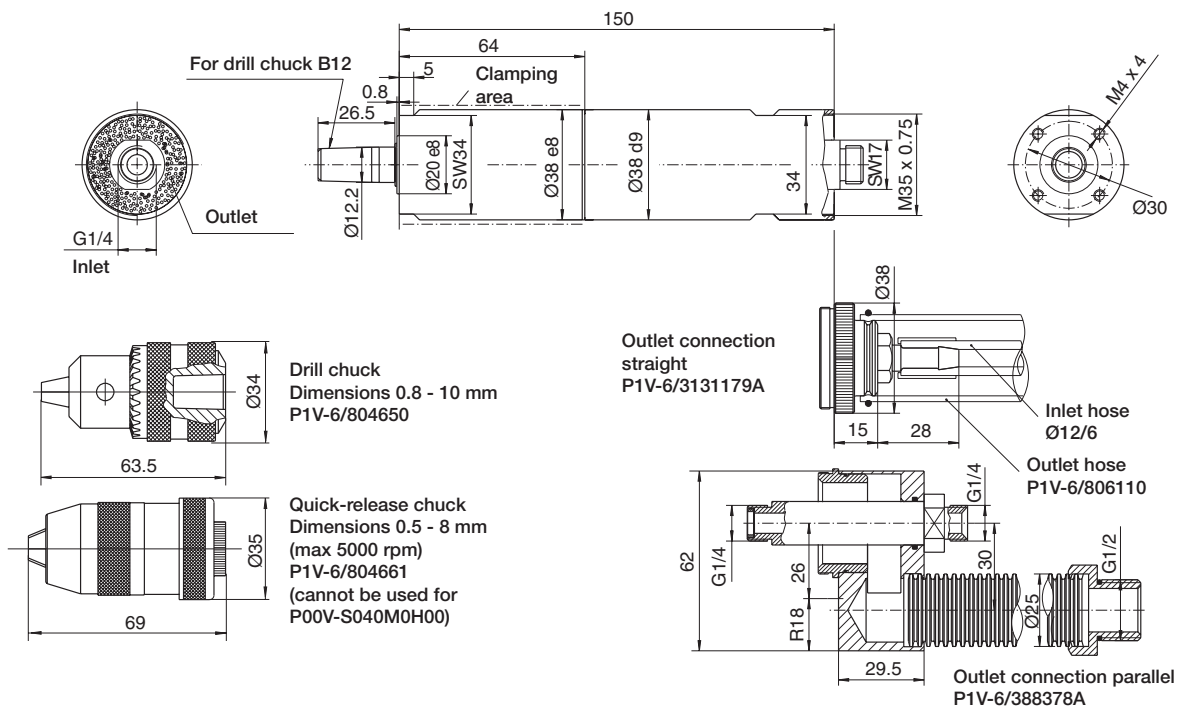
**Drilling motor for drill chuck P1V-S040M**

Max power kW	Free speed rpm	Version	Drilling in steel mm	Drilling in aluminium mm	Air consumption at max power l/s	Conn.	Min pipe ID mm	Weight Kg	Part number
0.250	17000	For drill chuck B12	-	6	8.0	G1/4o	6	0.82	<b>P1V-S040M0H00</b>
0.250	4800	For drill chuck B12	4	6	8.0	G1/4o	6	0.82	<b>P1V-S040M0480</b>
0.250	700	For drill chuck B12	6	8	8.0	G1/4o	6	0.82	<b>P1V-S040M0250</b>
0.250	350	For drill chuck B12	8	10	8.0	G1/4o	6	0.92	<b>P1V-S040M0140</b>

**Accessories**

Type	Part number
Standard drill chuck, diameters 0.8 – 10 mm/B12	<b>P1V-6/804650</b>
Quick-release chuck, diameters 0.5 – 8 mm/B12 (Cannot be used for drilling motor P1V-S040M0H00)	<b>P1V-6/804661</b>
Outlet connection straight	<b>P1V-6/3131179A</b>
Outlet hose Ø23 x 28 mm 0.75 m long	<b>P1V-6/806110</b>
Outlet connection parallel	<b>P1V-6/388378A</b>

**Dimensions – Drilling motor for drill chuck P1V-S040M**



Stainless Steel  
Stainless Steel with Brakes  
High Torque Stainless Steel  
Drilling, Milling & Grinding  
Air Motors



For inventory, lead time, and kit lookup, visit [www.pdnplu.com](http://www.pdnplu.com)

Specifications – 600 Watts

Drilling motor for drill chuck P1V-S060M

Our large drilling motor is used for small-scale heavy drilling operations requiring considerable feed force.

Select drill chucks or quick-release chucks as accessories as necessary.

The motor has a built-in silencer for exhaust air. If lower noise levels are required, or if you want the exhaust air to be collected, the relevant accessories are available.



**NOTE!** All technical data are based on a working pressure of 6 bar and with oil. For oil-free performances are -10 to 15% lower. Data tolerance accuracy +-10%

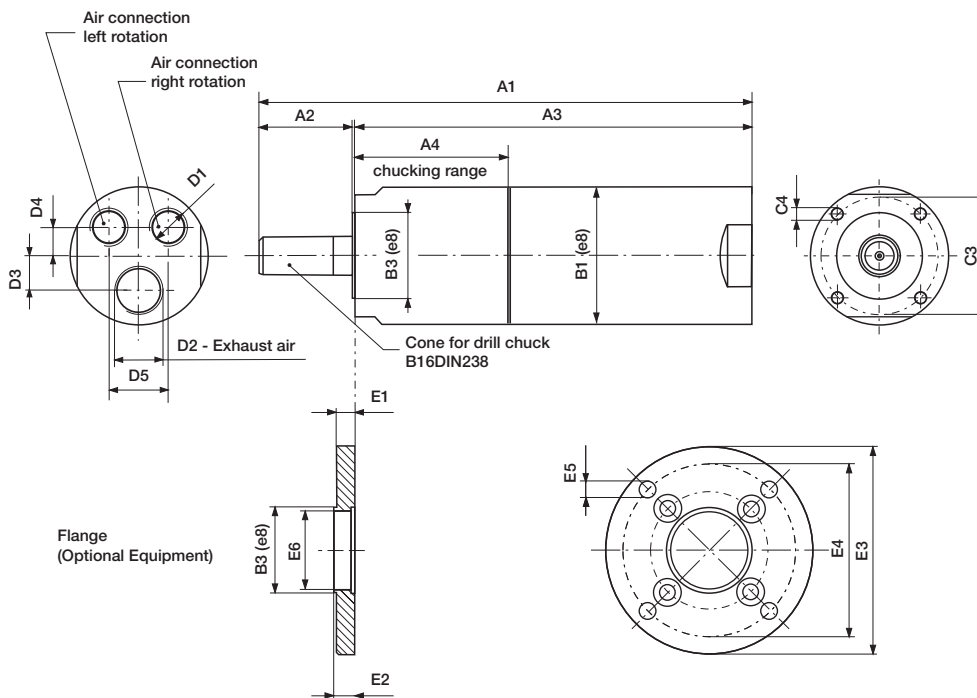
Drilling motor for drill chuck P1V-S060M

Max power kW	Free speed rpm	Version	Drilling in steel mm	Drilling in aluminium mm	Air consumption at max power l/s	Conn.	Min pipe ID mm	Weight Kg	Part number
0.60	3,500	For drill chuck B16	3	3	14.2	G3/8	12	2.1	<b>P1V-S060M0350</b>
0.60	2,700	For drill chuck B16	5	5	14.2	G3/8	12	2.1	<b>P1V-S060M0270</b>
0.60	1,700	For drill chuck B16	8	8	14.2	G3/8	12	2.1	<b>P1V-S060M0170</b>
0.60	630	For drill chuck B16	13	13	14.2	G3/8	12	2.2	<b>P1V-S060M0063</b>
0.60	480	For drill chuck B16	13	13	14.2	G3/8	12	2.3	<b>P1V-S060M0048</b>
0.60	300	For drill chuck B16	13	13	14.2	G3/8	12	2.3	<b>P1V-S060M0030</b>
0.60	150	For drill chuck B16	13	13	14.2	G3/8	12	2.3	<b>P1V-S060M0015</b>

Accessories

Type	Part number
Standard drill chuck, diameters 1 – 13 mm/B16	<b>P1V-6/804652</b>
Quick-release chuck, diameters 1 – 13 mm/B16	<b>P1V-6/804663</b>

Dimensions – Drilling motor for drill chuck P1V-S060M



For inventory, lead times, and kit lookup, visit [www.pdnplu.com](http://www.pdnplu.com)

**Mountings for P1V-S air motors**

Type	For air motor	Weight Kg	Part number
<b>Flange</b>			
	P1V-S008	0.04	<b>P1V-S4008B</b>
	P1V-S025	0.09	<b>P1V-S4020B</b>
	P1V-S040	0.12	<b>P1V-S4030B</b>
	P1V-S060	0.25	<b>P1V-S4060B</b>
<b>Foot bracket</b>			
	P1V-S008	0.08	<b>P1V-S4008F</b>
	P1V-S025	0.11	<b>P1V-S4020F</b>
	P1V-S040	0.11	<b>P1V-S4030F</b>
	P1V-S600	0.30	<b>P1V-S4060F</b>

All brackets supplied with fastening screws for the motor.

Stainless Steel

Stainless Steel  
with Brakes

High Torque  
Stainless Steel

Drilling, Milling &  
Grinding

Air Motors



Specifications – 90 W

Grinding gear motor with collet (no vanes) P1V-S009N

The grinding motor is used for small-scale point grinding and small-scale milling where the high speed is an advantage. It has proved to be very useful for drilling small holes and milling thin slits in PCBs in the electronics industry.

In this application, the high speed means that the holes and slits are free of burrs on the underside.

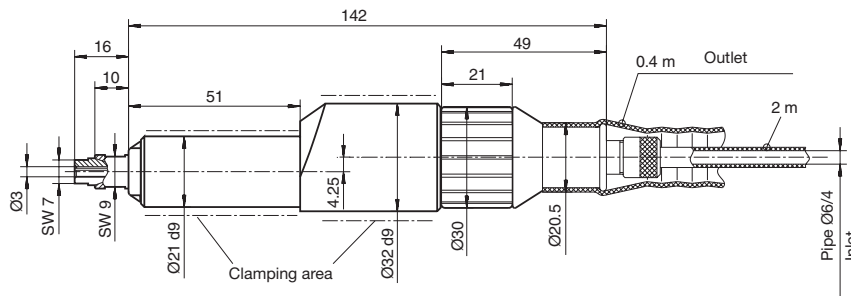


**NOTE!** All technical data are based on a working pressure of 6 bar and with oil. For oil-free performances are -10 to 15% lower. Data tolerance accuracy +-10%

Grinding gear motor with collet (no vanes) 90 W

Max power kW	Free speed rpm	Version	Point grinding diameter max mm	Milling diameter max mm	Air consumption at max power l/s	Conn.	Min pipe ID mm	Weight Kg	Part number
0.09	100,000	Collet 3 mm	3	5	2.0	Pipe 6/4	4	0.3	<b>P1V-S009N0A000</b>

Dimensions – Grinding motor P1V-S009N0A000



**Grinding motors with collets 150, 250 & 300 W**

This grinding motor is used when larger-scale point grinding is required. The motor can also be used for light milling operations. The motor has a built-in silencer for exhaust air.

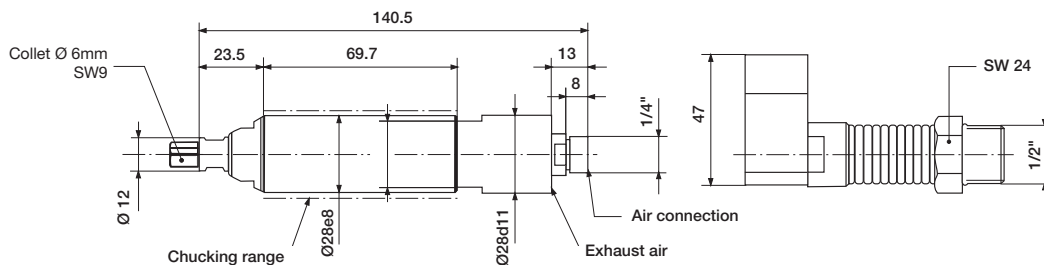
**NOTE!** All technical data are based on a working pressure of 6 bar and with oil. For oil-free performances are -10 to 15% lower. Data tolerance accuracy +-10%



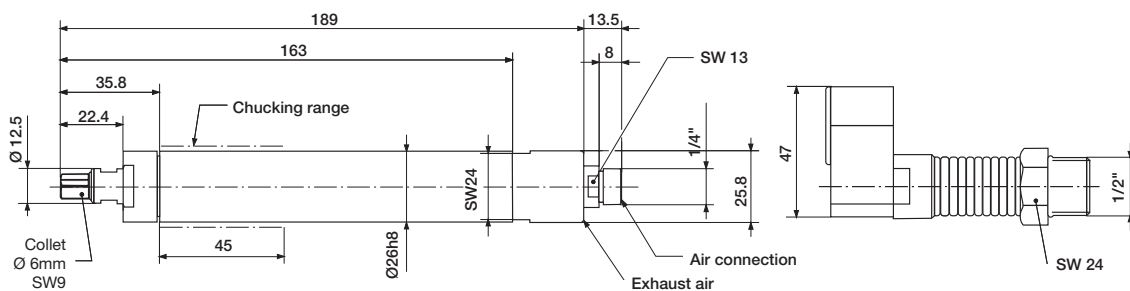
**Grinding motors with collets 150, 250 & 300 W**

Max power kW	Free speed rpm	Version	Point grinding diameter max mm	Milling diameter max mm	Air consumption at max power l/s	Conn.	Min pipe ID mm	Weight Kg	Part number
0.15	47,000	Collet 6 mm	-	-	X	G1/4o	6	0.36	<b>P1V-S015N0AQ0</b>
0.25	32,000	Collet 6 mm	-	-	X	G1/4o	6	0.80	<b>P1V-S025N0Z00</b>
0.30	30,000	Collet 6 mm	-	-	X	G1/4o	6	0.70	<b>P1V-S030N0X00</b>
0.30	45,000	Collet 6 mm	-	-	X	-	6	0.70	<b>P1V-S030N0AN0</b>

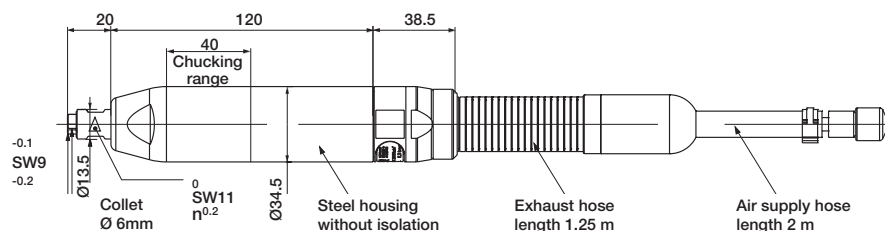
**Grinding motor P1V-S015N0AQ0**



**Grinding motor P1V-S025N0Z00**



**Grinding motor P1V-S030N0X00 & P1V-S030N0AN0**



For inventory, lead time, and kit lookup, visit [www.pdnplu.com](http://www.pdnplu.com)

Stainless Steel

Stainless Steel with Brakes

High Torque Stainless Steel

Drilling, Milling & Grinding

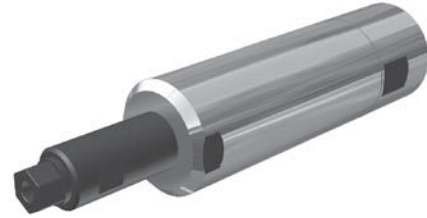
Air Motors



Specifications – 400 Watts

Milling motor with collet P1V-S040N

This motor was designed for milling plastic components, but it can also be used for milling other materials. The motor has a built-in silencer for exhaust air. If lower noise levels are required, or if you want the exhaust air to be collected, the relevant accessories are available.



**NOTE!** All technical data are based on a working pressure of 6 bar and with oil. For oil-free performances are -10 to 15% lower. Data tolerance accuracy +-10%

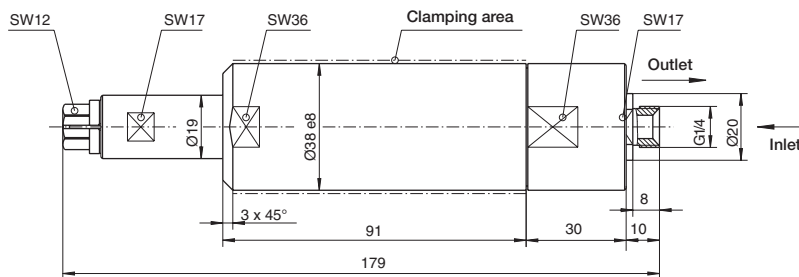
Drilling motor with collet P1V-S040N

Max power kW	Free speed rpm	Version	Milling of plastic mill dia. mm	Milling of wood mill dia. mm	Air consumption at max power l/s	Conn.	Min pipe ID mm	Weight Kg	Part number
0.40	20,000	Collet 8mm	8	10	5.0	G1/4o	6	0.80	<b>P1V-S040N0L00</b>

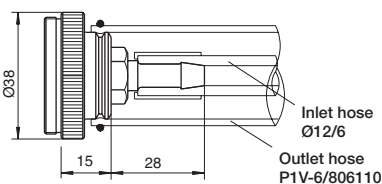
Accessories

Type	Part number
Collet Ø3 mm	<b>P1V-6/312690</b>
Collet Ø4 mm	<b>P1V-6/312692</b>
Collet Ø5 mm	<b>P1V-6/312693</b>
Collet Ø6 mm	<b>P1V-6/312694</b>
Collet Ø8 mm	<b>Included with the motor</b>
Collet Ø1/8"	<b>P1V-6/312691</b>
Collet Ø1/4"	<b>P1V-6/312695</b>
Outlet connection straight	<b>P1V-6/313179A</b>
Outlet hose Ø23 x 28 mm 0.75 m long	<b>P1V-6/806110</b>
Outlet connection parallel	<b>P1V-6/388378A</b>

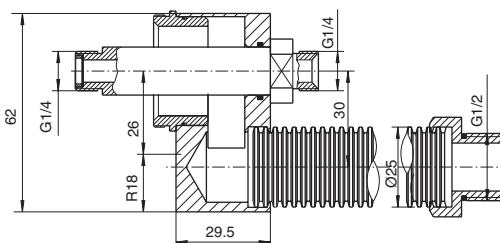
Dimensions – Milling motor with collet P1V-S040N0L00



Outlet connection straight  
P1V-6/313179A



Outlet connection parallel  
P1V-6/388378A



For inventory, lead times, and kit lookup, visit [www.pdnplu.com](http://www.pdnplu.com)

J70

**Parker Hannifin Corporation**  
Pneumatic Division  
Richland, Michigan  
[www.parker.com/pneumatics](http://www.parker.com/pneumatics)



Milling motors with collets 500, 700 & 1000 W

This motor was designed for milling plastic components, but it can also be used for milling other materials.

The motor has a built-in silencer for exhaust air. If lower noise levels are required, or if you want the exhaust air to be collected, the relevant accessories are available.

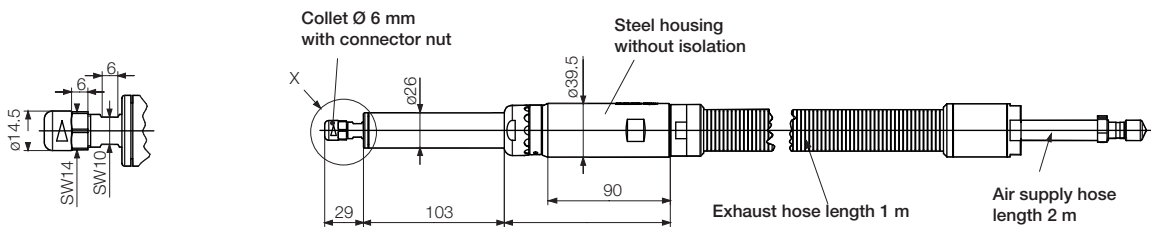
**NOTE!** All technical data are based on a working pressure of 6 bar and with oil. For oil-free performances are -10 to 15% lower. Data tolerance accuracy +-10%



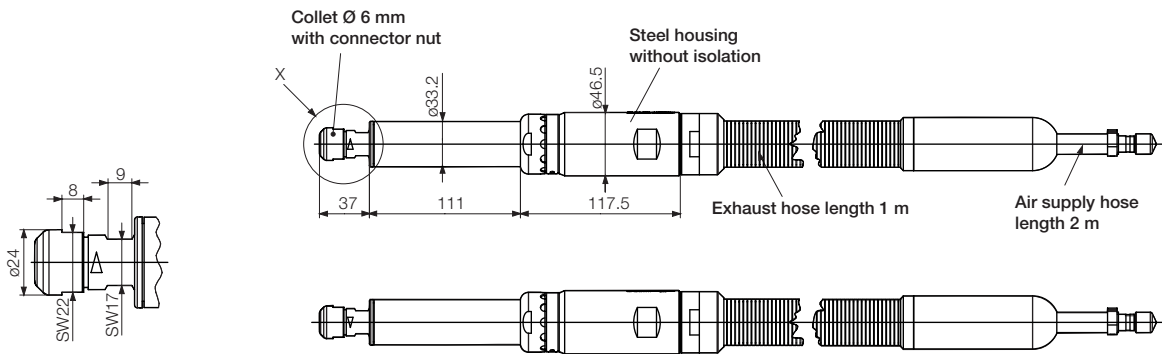
Milling motors with collets 500, 700 & 1000 W

Max power kW	Free speed rpm	Version	Air consumption at max power l/s	Conn.	Min pipe ID mm	Weight Kg	Part number
0.50	20,000	Collet 8 mm	15.0	-	10	1.20	<b>P1V-S050N0L00</b>
0.70	19,000	Collet 8 mm	15.0	-	10	1.70	<b>P1V-S070N0N00</b>
1.00	15,300	Collet 8 mm	16.7	-	12	1.70	<b>P1V-S100N0F30</b>

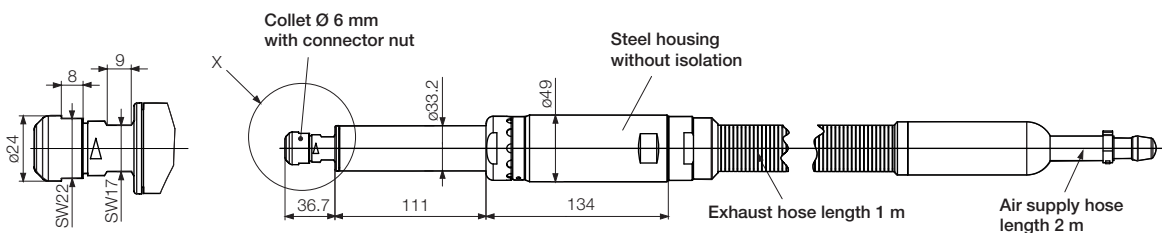
Milling motor with collet P1V-S050N0L00



Milling motor with collet P1V-S070N0N00



Milling motor with collet P1V-S100N0F30



For inventory, lead time, and kit lookup, visit [www.pdnplu.com](http://www.pdnplu.com)

Stainless Steel

Stainless Steel with Brakes

High Torque Stainless Steel

Drilling, Milling & Grinding

Air Motors

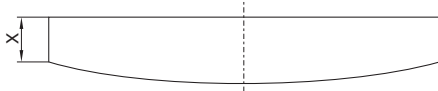


**Service & Kits**

**Lubrication and service life**



The first service is due after approximately 500 hours of operation. After the first service, the service interval is determined by the degree of vane wear\*. The table below shows new dimensions and the minimum dimensions of worn vanes.



Drilling motors	New dimensions X (mm)	Minimum dimensions X (mm)
<b>P1V-S008</b>	4.3	4.0
<b>P1V-S017</b>	4.2	3.3
<b>P1V-S025</b>	6.5	5.8
<b>P1V-S040</b>	6.8	6.0

Milling motors	New dimensions X (mm)	Minimum dimensions X (mm)
<b>P1V-S040</b>	X	X
<b>P1V-S050</b>	X	X
<b>P1V-S070</b>	X	X
<b>P1V-S100</b>	X	X

Grinding motors	New dimensions X (mm)	Minimum dimensions X (mm)
<b>P1V-S009</b>	No vanes	No vanes
<b>P1V-S015</b>	X	X
<b>P1V-S025</b>	X	X
<b>P1V-S030</b>	X	X



\* The specified hours of operation apply when the motor is running at the speed corresponding to maximum power (load speed).

This is approximately half free speed. If the motor operates at higher speeds, the service interval is shorter. If the motor operates at lower speeds, the service interval is longer.

**Air Motors**

**P1V-S Air Tools - Drilling, Grinding, Milling**

**Service kits for drilling, milling and grinding motors**

The following kits are available for the motors, consisting of vanes, (springs), silencers, O-rings, seals and 50 g of grease: (USDA-H1 approved)



**Service kits**

For drilling motors	Part number
P1V-S008N	<b>P1V-6/446085A</b>
P1V-S017N/M	<b>P1V-6/446086A</b>
P1V-S025N/M	<b>P1V-6/446087A</b>
P1V-S040M	<b>P1V-6/446088A</b>
P1V-S060M0350	<b>9121720604</b>
P1V-S060M0270	<b>9121720604</b>
P1V-S060M0170	<b>9121720604</b>
P1V-S060M0063	<b>9121720604</b>
P1V-S060M0048	<b>9121720605</b>
P1V-S060M0030	<b>9121720605</b>
P1V-S060M0015	<b>9121720605</b>

For milling motors	Part number
P1V-S040N	<b>P1V-6/446088A</b>
P1V-S050N	<b>P1V-6/4405021B</b>
P1V-S070N	<b>P1V-6/4405021C</b>
P1V-S100N	<b>P1V-6/4405021D</b>

For grinding motors	Part number
P1V-S009N	<b>Service free</b>
P1V-S015N	<b>P1V-6/4449221A</b>
P1V-S025N	<b>P1V-6/4449211A</b>
P1V-S030N	<b>P1V-6/4405021B</b>



For inventory, lead times, and kit lookup, visit [www.pdnplu.com](http://www.pdnplu.com)

## Actuator Accessories



### Linear Alignment Couplers

Technical Data	K2
Overview	K13

### Flow Controls

Microlok Flow Controls	K3
Brass Flow Controls	K4
Blocking Valves	K5

### 4TK Air-Oil Tank Series

Features	K6
Technical Data	K7-K8

### PRL Series – Stand Alone Rod-Lock

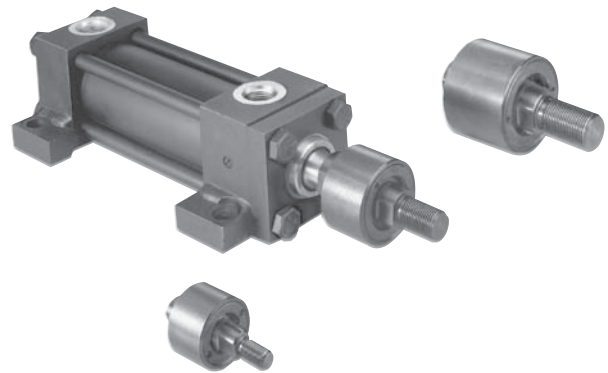
Features	K9
Ordering Information	K9
Technical Data	K10

## Linear Alignment Couplers

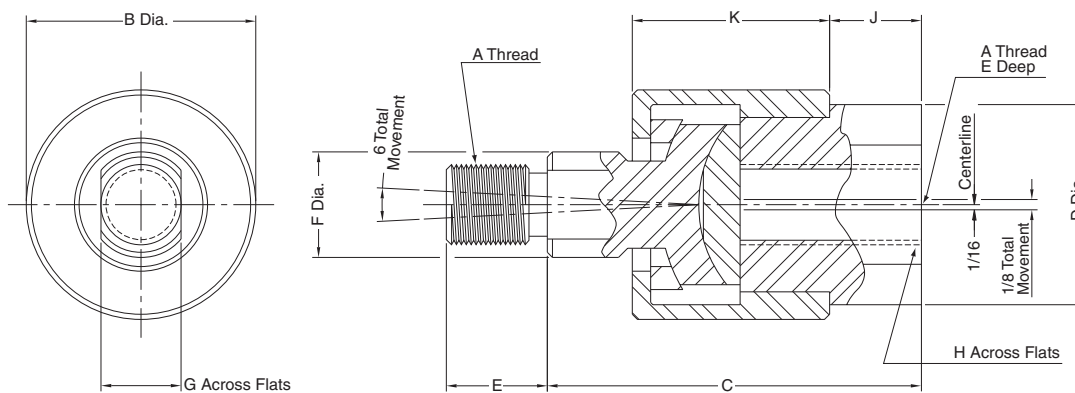
Linear Alignment Couplers are available in 12 standard thread sizes...

**Cost Saving Features and Benefits Include...**

- Maximum reliability for trouble-free operation, long life and lower operating costs
- Increased cylinder life by reducing wear on piston and rod bearings
- Stainless steel versions available. Please consult factory.
- Simplifying cylinder installation and reducing assembly costs
- Increase rod bearing and rod seal life for lower maintenance costs



**Alignment coupler**



**Part numbers and dimensions**

A	B	C	D	E	F	G	H	J	K	Max. pull load (lbs.)	Approx. weight (Lbs.)	Part number
5/16 -24	1-1/8	1-3/4	15/16	1/2	1/2	3/8	3/4	3/8	15/16	1200	0.35	1347570031
3/8 -24	1-1/8	1-3/4	15/16	1/2	1/2	3/8	3/4	3/8	15/16	2425	0.35	1347570038
7/16 -20	1-3/8	2	1-1/8	3/4	5/8	1/2	7/8	3/8	1-3/32	3250	0.55	1347570044
1/2 -20	1-3/8	2	1-1/8	3/4	5/8	1/2	7/8	3/8	1-3/32	4450	0.55	1347570050
5/8 -18	1-3/8	2	1-1/8	3/4	5/8	1/2	7/8	3/8	1-3/32	6800	0.55	1347570063
3/4 -16	2	2-5/16	1-5/8	1-1/8	1-5/16	3/4	1-5/16	7/16	1-9/32	9050	1.4	1347570075
7/8 -14	2	2-5/16	1-5/8	1-1/8	1-5/16	3/4	1-5/16	7/16	1-9/32	14450	1.4	1347570088
1-14	3-1/8	3	2-3/8	1-5/8	1-7/16	1-1/4	1-7/8	3/4	1-25/32	19425	4.8	1347570100
1-1/4 -12	3-1/8	3	2-3/8	1-5/8	1-7/16	1-1/4	1-7/8	3/4	1-25/32	30500	4.8	1347570125
1-1/4 -12	3-1/2	4	2	2	1-1/2	1-1/4	1-11/16	3/4	2-1/2	30500	6.9	1337390125
1-1/2 -12	4	4-3/8	2-1/4	2-1/4	1-3/4	1-1/2	1-15/16	7/8	2-3/4	45750	9.8	1337390150
1-3/4 -12	4	4-3/8	2-1/4	2-1/4	1-3/4	1-1/2	1-15/16	7/8	2-3/4	58350	9.8	1337390175
1-7/8 -12	5	5-5/8	3	3	2-1/4	1-15/16	2-5/8	1-3/8	3-3/8	67550	19.8	1337390188

**How to order linear alignment couplers**

When ordering a cylinder with a threaded male rod end, specify the coupler of equal thread size by part number as listed in Table 1, i.e.; Piston Rod "KK" or "CC" dimension is 3/4" - 16", specify coupler part number 1347570075.



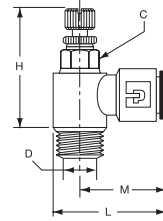
For inventory, lead times, and kit lookup, visit [www.pdnplu.com](http://www.pdnplu.com)

Linear Alignment  
Flow Controls  
4TK Series  
PRL Series  
Actuator Accessories  
K

## Flow Controls & Connectors

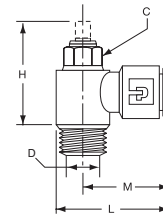
### Miniature Exhaust Flow Control

Tube size	Thread size	C Hex mm	H Closed	H Open	L	M	Flow dia. D	Part number
5/32	10-32	6	0.925	1.023	0.846	0.669	0.080	0876300100
5/32	1/8	7	1.000	1.083	0.935	0.708	0.100	0876300200
1/4	10-32	6	0.925	1.023	0.885	0.708	0.080	FCM731-4-0
1/4	1/8	7	1.000	1.083	0.957	0.730	0.100	FCM731-4-2
1/4	1/4	8	1.083	1.180	1.013	0.748	0.160	0876300500



### Knobless Miniature Exhaust Flow Control

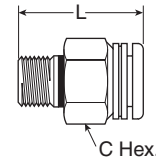
Tube size	Thread size	C Hex mm	H closed	H open	L	M	Flow dia. D	Part number
5/32	10-32	6	0.650	0.787	0.846	0.669	0.080	0876310100
1/4	1/8	7	0.708	0.860	0.956	0.730	0.100	0876310200
1/4	1/4	8	0.826	0.964	1.013	0.748	0.160	0876310300



### Global Connect Fittings

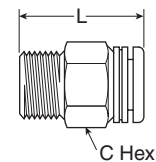
#### 68GC Male Connector

Tube size	Pipe thread	C Hex.	L	Part number
1/8	10-32	1/2	0.925	68GC-2-0
5/32	10-32	1/2	0.913	68PLP-5/32-0
3/16	10-32	9/16	0.898	68GC-3-0
1/4	10-32	9/16	0.898	68GC-4-0

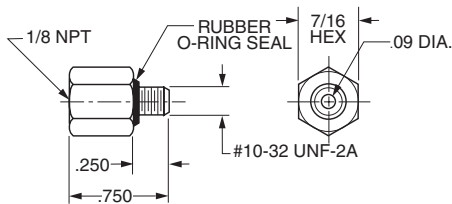


#### W68GC Male Connector

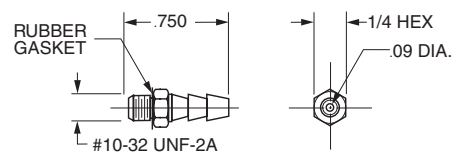
Tube size	Pipe thread	C hex.	L	Part number
1/8	1/16	1/2	0.945	W68GC-2-1
1/8	1/8	1/2	0.945	W68GC-2-2
1/8	1/4	9/16	1.150	W68GC-2-4
5/32	1/16	1/2	0.937	W68GC-5/32-1
5/32	1/8	1/2	0.937	W68GC-5/32-2
5/32	1/4	9/16	1.142	W68GC-5/32-4
3/16	1/8	9/16	0.980	W68GC-3-2
3/16	1/4	9/16	1.181	W68GC-3-4
1/4	1/16	9/16	1.134	W68GC-4-1
1/4	1/8	9/16	0.980	W68GC-4-2
1/4	1/4	9/16	1.181	W68GC-4-4
1/4	3/8	13/16	1.185	W68GC-4-6



Port adapter	Part number
#10-32 to 1/8-27	1442840000



Hose barbed fittings	Part number
1/4" O.D. (Pkg. of 10)	L06998 0000



**Note:** Due to insufficient port depth, port adapter fitting cannot be used for head end ports of 9/16" bore cylinders. Use barbed fitting.



For inventory, lead time, and kit lookup, visit [www.pdnplu.com](http://www.pdnplu.com)

Linear Alignment

Flow Controls

4TK Series

PRL Series

Actuator Accessories

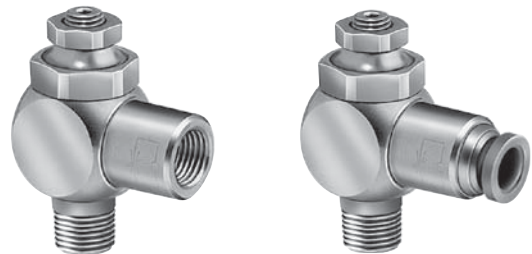
**K**

**Brass Right Angle Flow Controls**

The Right Angle Flow Control is an ideal solution to cylinder speed control where space is at a premium. Costly fittings, connections and piping expenses can be eliminated because the valve can rotate 360°, the piping alignment can be in any direction. It then locks into place. The 1/8" model can be rotated after final assembly.

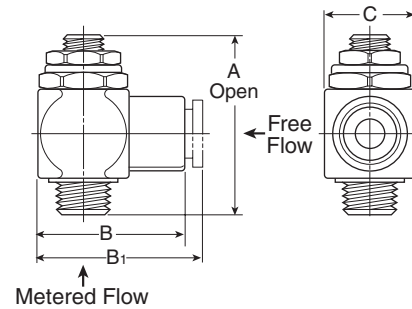
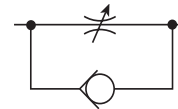
Install by threading male end directly into cylinder port. The free-flow and metered-flow direction is automatically predetermined. Free-flow direction is into cylinder and metered-flow is out of the cylinder. Flow is adjusted with an Allen wrench and locked with nut.

Right Angle Flow Control also available with Prestolok fittings on inlet port to accommodate 5/32 - 3/8 tube sizes. This allows for quick connection and eliminates need for separate tube fitting.



**Threaded Inlet**

**Prestolok Inlet Fitting**



**Specifications**

- Body: Brass
- Plunger: Brass and Acetal
- Seals: Buna N
- Temperature Range: 0°F to 140°F (-18°C to 60°C)
- Pressure Rating: 125 PSIG (8.6 bar) max.

**Model Selection and Dimensions**

**Threaded Inlet**

Male thread (NPT)	Female thread (NPT)	A Inch (mm)	B Inch (mm)	C Inch (mm)	Weight oz. (kg)	Cv		Part number
						Adjusted Flow	Free Flow	
1/8	1/8	1.74 (44)	1.18 (30)	.67 (17)	2.0 (0.9)	0.26	0.20	032510125
1/4	1/4	1.99 (51)	1.40 (36)	.91 (23)	4.5 (2.0)	0.75	0.68	032510250
3/8	3/8	2.28 (58)	1.71 (43)	1.06 (27)	7.0 (3.2)	0.84	0.72	032510375
1/2	1/2	2.69 (68)	1.98 (53)	1.26 (32)	11.0 (5.0)	1.64	1.41	032510500

**With Prestolok Fittings**

Thread (NPT)	Tube Size (OD)	A Inch (mm)	B1 Inch (mm)	C Inch (mm)	Weight oz. (kg)	Cv		Part number
						Adjusted Flow	Free Flow	
1/8	5/32	1.74 (44)	1.18 (30)	.67 (17)	2.0 (0.9)	0.19	0.16	032511215
1/8	1/4	1.74 (44)	1.18 (30)	.67 (17)	2.0 (0.9)	0.28	0.22	032511225
1/4	1/4	1.99 (51)	1.40 (36)	.91 (23)	4.5 (2.0)	0.51	0.44	032512525
1/4	3/8	1.99 (51)	1.40 (36)	.91 (23)	4.5 (2.0)	0.62	0.53	032512538
3/8	3/8	2.28 (58)	1.71 (43)	1.06 (27)	7.0 (3.2)	0.78	0.65	032513838

**CAUTION:** If it is possible that the ambient temperature may fall below freezing, the medium must be moisture-free to prevent internal damage or unpredictable behavior.

Linear Alignment

Flow Controls

4TK Series

PRL Series

Actuator Accessories

**K**



For inventory, lead times, and kit lookup, visit [www.pdnplu.com](http://www.pdnplu.com)

**Blocking Valves**

Blocking valves are designed for precise, repeatable stopping of moving cylinders or to maintain the position of a cylinder in the event of an air pilot signal loss. Blockers are used for positioning and jogging purposes.

A blocking valve has a spring loaded poppet which normally prevents flow through the valve in both directions. When an air pilot control signal (see pilot pressure chart below for required pilot signal pressure) is applied to the top of the valve, the poppet opens and allows the valve to flow in both directions like a standard fitting. When the pilot signal is removed, the poppet springs shut and prevents air from entering or leaving cylinder, thus stopping cylinder travel.

Blocking valves are designed to be installed directly into actuator ports (up to 5" bore cylinders).

**Specifications**

- Operating Pressure: 0 to 145 PSI (0 to 10 Bar)
- Temperature Range: 5°F to 140°F (-15°C to 60°C)
- Maximum Operating Frequency: 10 Hz
- Life Expectancy: 10 million cycles @ 90 PSIG, 68°F, dry filtered air and 1 Hz operating frequency
- Materials: Zinc alloy body; brass mounting screw and threads

**Pilot Pressure (PSI)**

Operating Pressure	Cylinder Port Size							
	1/8"		1/4"		3/8"		1/2"	
	Pilot	Depilot	Pilot	Depilot	Pilot	Depilot	Pilot	Depilot
30	34	22	34	22	36	21	45	26
60	40	26	40	26	40	25	50	31
90	45	31	45	31	45	30	54	35
115	50	35	50	35	50	34	59	41

**With Instant Tube Fittings**

Cylinder port	Tube size (OD)	Pilot tube (OD)	Flow (Cv)	Wt. (oz)	Part number
1/8"	1/4"	5/32"	0.78	5.1	<b>PWBA3468</b>
1/4"	1/4"	5/32"	1.02	5.3	<b>PWBA3469</b>
3/8"	3/8"	5/32"	1.67	6.3	<b>PWBA3493</b>
1/2"	1/2"	5/32"	2.12	17.5	<b>PWBA3412</b>

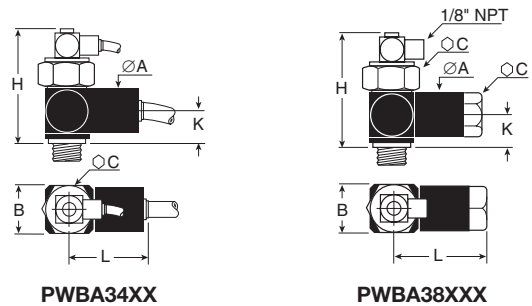
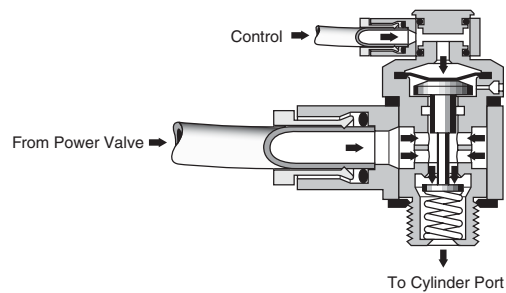
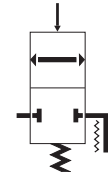
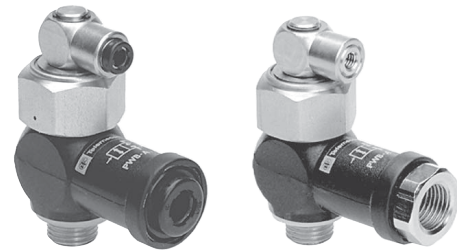
**With NPT Threaded Connections & Tube Pilot Port**

Cylinder port	Female port	Pilot port	Flow (Cv)	Wt. (oz)	Part number
1/8"	1/8"	5/32"*	0.78	6.2	<b>PWBA3888</b>
1/4"	1/4"	5/32"*	1.02	6.2	<b>PWBA3899</b>
3/8"	3/8"	10-32	1.67	6.7	<b>PWBA3833</b>
1/2"	1/2"	10-32	2.12	16.8	<b>PWBA3822</b>

**With NPT Threaded Connections & Pilot Port**

Cylinder port	Female port	Pilot port	Flow (Cv)	Wt. (oz)	Part number
1/8"	1/8"	1/8"	0.78	6.2	<b>PWBA38887</b>
1/4"	1/4"	1/8"	1.02	6.2	<b>PWBA38997</b>
3/8"	3/8"	1/8"	1.67	6.7	<b>PWBA38337</b>
1/2"	1/2"	1/8"	2.12	16.8	<b>PWBA38227</b>

\*Instant tube connection



**Dimensions**

Cyl. Port Size	A Dia.	B	C Hex	H	K	L	L1
1/8"	22 (0.90)	21 (0.86)	15/16"	59 (2.41)	19.5 (0.80)	39 (1.59)	43.5 (1.78)
1/4"	22 (0.90)	21 (0.86)	15/16"	53 (2.16)	13.5 (0.55)	39 (1.59)	43.5 (1.78)
3/8"	27 (1.10)	28 (1.14)	15/16"	53 (2.16)	14 (0.57)	50 (2.04)	55.5 (2.27)
1/2"	31 (1.27)	33 (1.35)	1-1/4"	66 (2.69)	24 (0.98)	66 (2.69)	63 (2.57)

Dimensions in mm (inch)

Linear Alignment

Flow Controls

4TK Series

PRL Series

Actuator Accessories

**K**



For inventory, lead time, and kit lookup, visit [www.pdnplu.com](http://www.pdnplu.com)

Features

4TK Air-Oil Tanks – For Smoother Hydraulic Flow

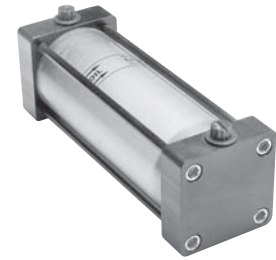
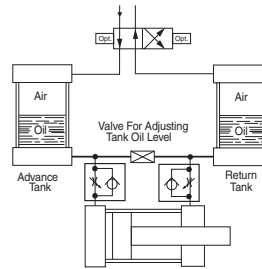
Parker Air-Oil tanks provide a means to convert shop air pressure into hydraulic pressure. Compressed air is applied directly to the oil in the air-oil tank to convert it into hydraulic pressure. The hydraulic pressure is at a 1-to-1 ratio, i.e. 80 PSIG air produces 80 PSIG hydraulic pressure.

All Parker Air-Oil tanks have a fiberglass tube which shows the proper oil level. They also contain two fluid flow baffles. The top baffle disperses the incoming air over the surface of the oil in such a way to avoid agitation and aeration. The bottom baffle insures a smooth flow pattern that minimizes oil turbulence and eliminates swirling, funneling or splashing which in turn could cause oil aeration or the oil to be blown from the tank into the exhaust air.

Air-Oil tanks are used to smooth out the cylinder piston rod travel and to prevent chatter. They are mainly used in slow speed circuits. Since each tank is designed for a specific port size, increasing the port size in a tank to lower the fluid velocity is not recommended. A tank with a larger port size should be selected.

**Fluid velocity in or out of the tank through standard ports should be less than 6 feet per second to prevent aeration of the oil.** To limit the fluid velocity, flow controls should be applied to the air side of the tank to restrict the exhaust. Metered-in flow controls on the air side may aid in the reduction of aeration. Additional flow controls on the oil side may aid in controlling the actuator motion.

In a basic air-oil circuit the advance tank is connected to the cap end port of a hydraulic cylinder and the return tank to the head end port. Shop air is applied alternately to the two tanks through a 4-way air control valve. The oil in the advance tank is forced into the cap end of the cylinder to cause the piston rod to extend. At the same time, oil from the head end port is forced into the return tank, the air side of which is open to exhaust. To return the



Operating information

Operating pressure	17 bar (250 PSIG) maximum
Operating temperature	74°C (165°F) maximum
Filtration requirements	40 micron, dry filtered air

cylinder to retract position, air pressure is applied to the oil in the return tank.

How to Select

**Step 1:** Determine the volume (cu. in.) of fluid required to fill the work cylinder at full stroke by taking the bore area times the stroke length.

**Step 2:** Select the proper tank bore height from the chart. Since there are usually several combinations with similar capacities, select the one having a rated capacity closest to but slightly greater than your volume requirements. Generally, the most economical choice is a higher tank with a smaller bore.

Rated capacities - cubic inches (in<sup>3</sup>)

Bore size	Usable tank volume (Cu. In.) per internal height of tank											
	4	6	8	10	12	14	16	18	20	24	28	32
2-1/2	9	17	27	35	44	52	62	70	79	97	115	132
3-1/4	16	30	46	60	76	91	107	121	137	167	198	228
4	18	33	58	73	98	120	144	166	191	237	283	330
5	29	53	92	116	155	189	228	261	300	373	446	519
6	42	77	133	168	224	273	329	378	434	539	645	750
8	75	137	237	300	400	487	587	675	775	963	1150	1338

Ordering information

<b>4.00</b>	<b>U</b>	<b>6.000</b>
<b>Tank diameter (inches)</b>	<b>Ports</b>	<b>Tank height*</b>
2.50	U NPTF	Internal height in inches
3.25		* Less than 4 Inches, Consult Factory
4.00		
5.00		
6.00		
8.00		
<b>Tank mounting style</b>	<b>Special modification</b>	
TEF Sleeve nut with side tap †	S Special	
TE Sleeve nut †		
TB Tie rods extended, air end		
TC Tie rods extended, oil end		
TD Tie rods extended, both ends		
C Side lug		
CB Side end angles		
NB Base bar		

† Not available on 6" & 8" bore sizes.  
**Note:** Standard air-oil tanks are designed for use with petroleum base hydraulic oil. If other fluids will be used, please consult the factory.

For ordering purposes, when special options or common modifications are requested, the factory will assign a sequential part number in place of the model number.



For inventory, lead times, and kit lookup, visit [www.pdnplu.com](http://www.pdnplu.com)



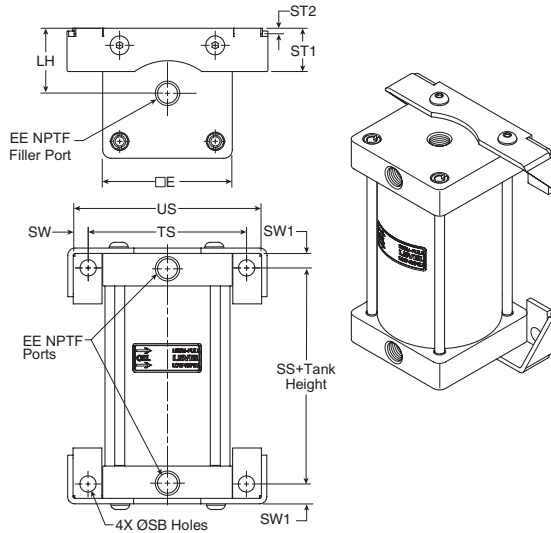
**Technical Data**

- Standard Bore Sizes 2-1/2" - 8"
- Operating Pressure 250 PSI Maximum
- Operating Temperature 165°F Maximum
- Lightweight Aluminum / Fiberglass Design
- Larger Bore Sizes Available Upon Request

**Mounting Dimensions**

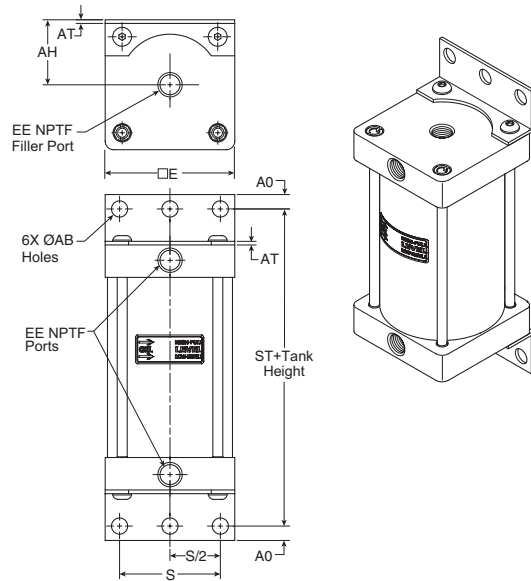
**Mounting Style C**

Side Lug



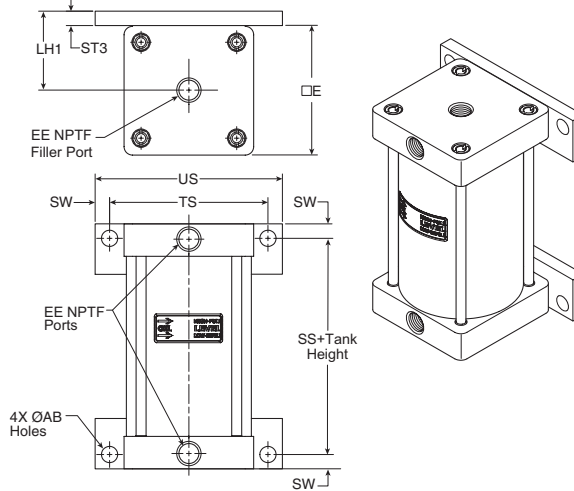
**Mounting Style CB**

Side End Angles



**Mounting Style NB**

Base Bar



**Dimensions - Styles C, CB and NB**

Bore	AB	AH	AO	AT	E	EE	LH	LH1	S	SB	ST1	ST2	ST3	SW	SW1	TS	US	Add tank height	
																		SS	ST
2-1/2	0.44	1.63	0.38	0.13	3.00	3/8	1.49	1.87	2.25	0.44	1.34	0.12	0.38	0.38	0.50	3.75	4.50	1.25	4.00
3-1/4	0.56	1.94	0.50	0.13	3.75	1/2	1.68	2.37	2.75	0.56	1.50	0.19	0.50	0.50	0.69	4.75	5.75	1.50	5.00
4	0.56	2.25	0.50	0.13	4.50	1/2	2.24	2.74	3.50	0.56	1.50	0.19	0.50	0.50	0.69	5.50	6.50	1.50	5.00
5*	0.69	2.75	0.63	0.19	5.50	1/2	2.74	-	4.25	0.81	1.50	0.25	-	0.69	0.94	6.88	8.25	1.13	5.75
6* †	0.81	3.25	0.63	0.19	6.50	3/4	-	-	5.25	-	-	-	-	-	-	-	-	-	5.75
8* †	0.81	4.25	0.69	0.25	8.50	3/4	-	-	7.13	-	-	-	-	-	-	-	-	-	6.63

\* Mounting Style NB available in 2-1/2" - 4" bore only.

† Mounting Style C available in 2-1/2" - 5" bore only.

Linear Alignment

Flow Controls

4TK Series

PRL Series

Actuator Accessories

**K**



For inventory, lead time, and kit lookup, visit [www.pdnplu.com](http://www.pdnplu.com)

**Mounting Dimensions**

**Mounting Style TEF**

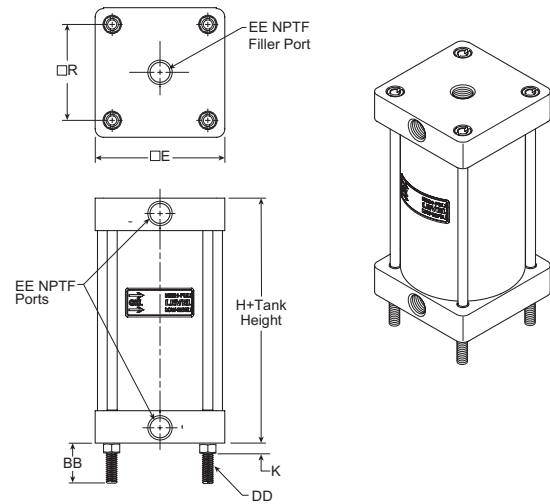
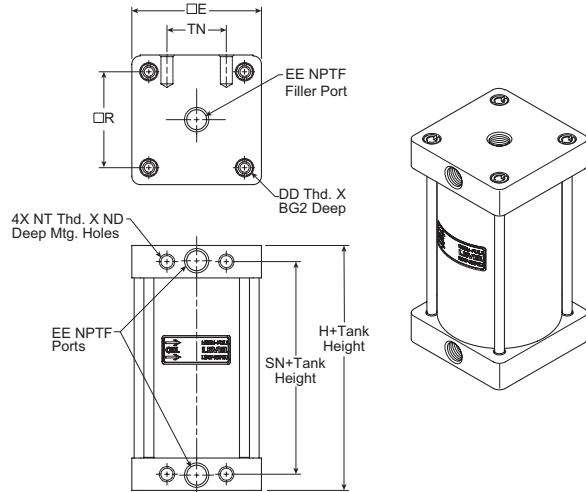
Sleeve Nut - With Side Tap

**Mounting Style TE**

Sleeve Nut

**Mounting Style TC**

Tie Rods Extended - Oil End

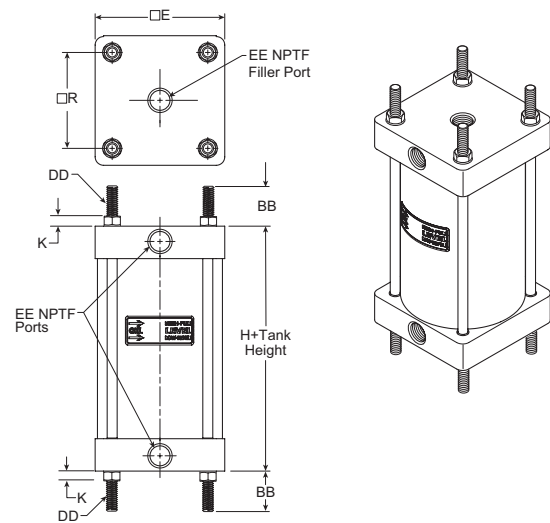
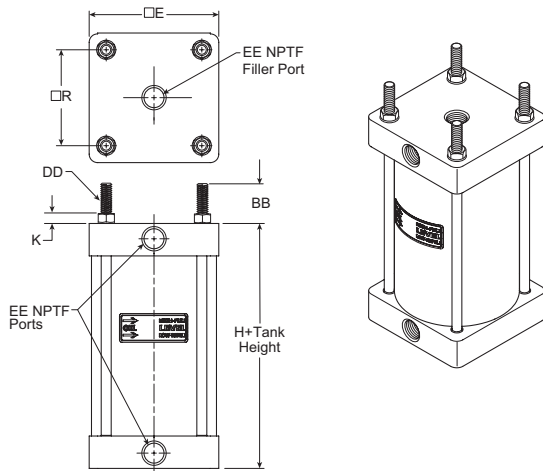


**Mounting Style TB**

Tie Rods Extended - Air End

**Mounting Style TD**

Tie Rods Extended - Both Ends



**Dimensions - Styles TEF, TE, TB, TC, and TD**

Bore	BB	BG2	DD	E	EE	K	ND	NT	R	TN	Add Tank Height	
											H	SN
2-1/2	1.12	0.39	5/16-24	3.00	3/8	0.32	0.63	3/8-16	2.19	1.25	2.00	1.13
3-1/4	1.38	0.47	3/8-24	3.75	1/2	0.38	0.75	1/2-13	2.76	1.50	2.50	1.38
4	1.38	0.47	3/8-24	4.50	1/2	0.38	0.75	1/2-13	3.32	2.06	2.50	1.38
5	1.81	0.50	1/2-20	5.50	1/2	0.44	0.94	5/8-11	4.10	2.69	3.00	1.88
6	1.81	0.50	1/2-20	6.50	3/4	0.44	1.13	3/4-10	4.88	3.25	3.00	1.63
8	2.32	0.63	5/8-18	8.50	3/4	0.56	1.13	3/4-10	6.44	4.50	3.00	1.63

Linear Alignment  
 Flow Controls  
 4TK Series  
 PRL Series  
 Actuator Accessories  
**K**



For inventory, lead times, and kit lookup, visit [www.pdnplu.com](http://www.pdnplu.com)

Features

**PRL Series**

The PRL Series rod lock is used in applications where the locking of linear travel is required. It is commonly used in work holding applications and for locking tools and fixtures in the event of air pressure or electrical control failure.

**Application**

- Clamping: Without an appropriate air signal to the rod lock pressure port, the rod lock clamps to the precision metric rod and prevents rod movement in the axial direction.
- Delatching: When 4 Bar (58 PSIG) of air pressure is applied to the port, the rod lock releases and allows free movement of the rod. This will be required for installation.
- Locking Direction: The rod lock is designed specifically to prevent rod movement in the axial direction only. It is not recommended for locking rotary rod motion.
- Rod Material: The Series PRL rod lock is a precision locking device, therefore strict rod tolerances and rod material specifications are required to ensure safe and proper operation. Minimum requirements for the rod material include a chrome plated surface finish of 10 micro inches or less and a surface hardness of 52 Rc. Rod material may be ordered separately in custom lengths. See next page for how to order.
- Environment: The rod lock is recommended for use in dry, clean conditions. Please take precautions to prevent moisture from entering the pressure port or the exhaust port of the locking device.

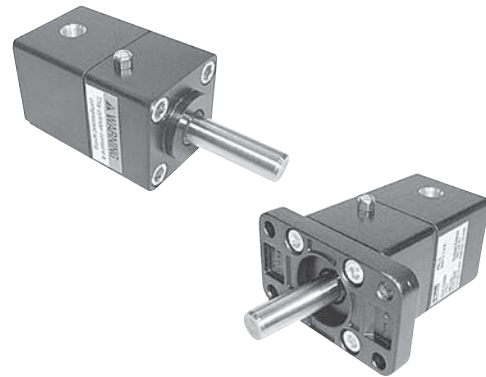
There should be no relative motion between the rod and the Rod Lock Device when the locking device is activated. The locking device is not intended to brake a movement in repeated sequences.

**Considerations for Rod Sizing**

When applying a rod lock device, it is important to consider the loading forces which will be imposed on the rod in the axial direction.

For applications where the rod lock and its associated load impose a compressive force on the rod, please consider the axial compression force and rod length to select the appropriate rod diameter for preventing rod buckling.

In situations where the rod lock and its associated load place the rod in tension, please take care to securely fasten the rod ends to the machine member.



**Operating information**

Working pressure	Max. 10 bar (145 PSIG)
Working temperature	-20° to 80°C (-4°F to 176°F)
Locking pressure	4 bar (58 PSIG) ±10%
Filtration requirements	40 micron, dry filtered air

**Holding Forces**

Model number	Holding force	
	Pounds (lbs.)	Newtons (N)
12PRL*	123	550
16PRL*	193	860
20PRL*	481	2140
25PRL*	1211	5390
32PRL*	1894	8425

\* Character reserved for port style

**Ordering information**

<b>25</b>	<b>PRL</b>	<b>U</b>	
<b>Rod diameter</b>		<b>Ports</b>	<b>S</b>   <b>Specials</b>
Specify 12, 16, 20, 25 or 32 (mm)		<b>U</b>   NPTF <b>R</b>   BSPP	Leave blank if no specials

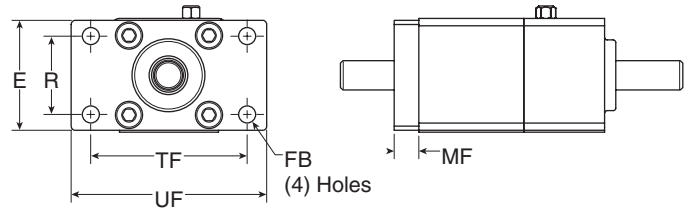
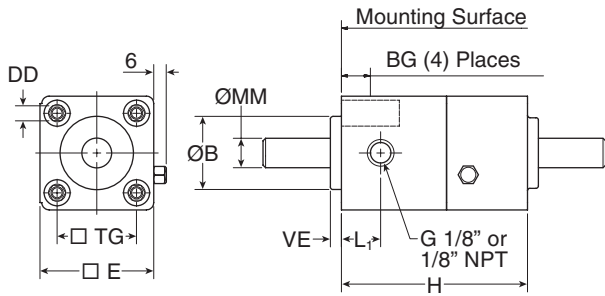
Linear Alignment  
 Flow Controls  
 4TK Series  
 PRL Series  
 Actuator Accessories  
**K**



For inventory, lead time, and kit lookup, visit [www.pdnplu.com](http://www.pdnplu.com)

**Basic rod lock**

**Rod lock with flange mount**



**Mounting dimensions**

Part	Rod dia. MM	B D11	BG	DD	E	FB	H	L1	MF	R	TF	TG	UF	VE
12PRL*	12.00 (-.04)	30	16	M6	46.5	7	76	16	10	32	64	32.5	80	4.5
16PRL*	16.00 (-.04)	35	16	M6	51	9	81.1	16	10	36	72	38	92	4.5
20PRL*	20.00 (-.04)	45	16	M8	76	9	100.8	26	12	50	100	56.5	129	5
25PRL*	25.00 (-.04)	55	16	M10	114.5	14	146	50	16	75	150	89	186	4
32PRL*	32.00 (-.04)	60	20	M12	140	16	165.2	60	20	90	180	110	220	6

\* Character reserved for port style

**Flange mounting kit**

Mounting kits are available separately from the rod lock device. Please use the following part numbers to order. Mounting fasteners are included with the kits.

Model number	Flange mount
12PRL*	L075370032
16PRL*	L075370040
20PRL*	L075370063
25PRL*	L075370100
32PRL*	L075370125

\* Character reserved for port style

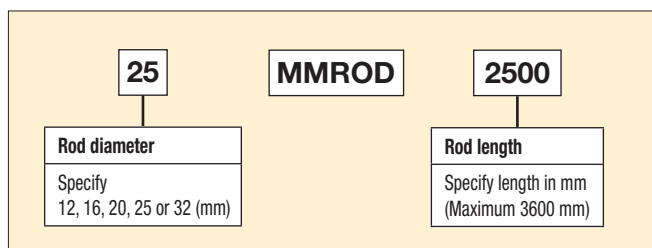
**Metric rod material**

Rods will be supplied in the specified length with chamfered ends. Please note, the rod material is case hardened and requires annealing prior to machining. Parker is pleased to quote custom machined rods per customer supplied drawings.



**Caution:** Using piston rod material which does not meet the tolerance and finished conditions as listed on the previous page may prevent the locking device from properly holding the intended load.

**How to Order**



For inventory, lead times, and kit lookup, visit [www.pdnplu.com](http://www.pdnplu.com)

Linear Alignment  
 Flow Controls  
 4TK Series  
 PRL Series  
 Actuator Accessories  
**K**



## Electronic Sensors

### Selection Guide

PNP, NPN, Reed	L2-L4
----------------	-------

### Drop-in Sensors

P8S Global	L5-L6
P8S Mini-Global	L7-L8
Bracket Assembly	L9

### Right Angle Sensors

P8S Series	L10
------------	-----

### Magnet Switches

OSP-P - Series RST & EST	L11-L12
--------------------------	---------

### Solid State & Reed Sensors

P1A Series	L13-
LP/LPM Series	L14-L15
PRNA Series	L16
PRN Series	L17
PV, XR Series	L18-L19
PTR Series	L20-L21

### Weld Immune Sensor

L22

### Air Piloted Switch

L23

### Female Quick Connect Cordset

8mm & 12mm	L24
------------	-----

### Valvetronic 110

Connection Block	L25
------------------	-----

### End-of-Stroke Proximity Sensors

EPS-6 & EPS-7	L26-L27
CLS-1 & CLS-4	L26-L27
Specifications	L28
For 4MA, 4MAJ Series	L29
For PTR & HP Series	L30
8mm Barrel Type	L30

## PNP Solid State Sensor Selection Guide

Series	Bore size or type	3m flying leads	10m flying leads	8mm quick connect*	8mm quick connect w/ 1 m lead*	12mm quick connect*	Bracket	Sensor page #	Bracket page #	
Compact cylinders	P1Q	12mm - 100mm	P8S-EPFXS <sup>1</sup>	N/A	P8S-EPSUS	N/A	N/A	N/A	N/A	
		9/16"	L076990000 <sup>2</sup>	N/A	L07699000C	N/A	N/A	N/A	L15	N/A
	LPM	3/4" - 1-1/8"	L077000000 <sup>2</sup>	N/A	L07700000C	N/A	N/A	N/A	L15	N/A
		1-1/2" - 2"	L077010000 <sup>2</sup>	N/A	L07701000C	N/A	N/A	N/A	L15	N/A
		2-1/2" - 4"	L077020000 <sup>2</sup>	N/A	L07702000C	N/A	N/A	N/A	L15	N/A
Round body cylinders	SR/ SRG, SRM/SRDM	9/16" - 3/4"	P8S-GPFAX	P8S-GPFDX	P8S-GPCHX	P8S-GPSCX	P8S-GPMHX	P8S-TMC01	L5	L9
		1-1/16" - 2-1/2"	P8S-GPFAX	P8S-GPFDX	P8S-GPCHX	P8S-GPSCX	P8S-GPMHX	P8S-TMC02	L5	L9
	P	1-1/8" - 2-1/2"	P8S-GPFAX	P8S-GPFDX	P8S-GPCHX	P8S-GPSCX	P8S-GPMHX	P8S-TMC02	L5	L9
		3" - 4"	P8S-GPFAX	P8S-GPFDX	P8S-GPCHX	P8S-GPSCX	P8S-GPMHX	P8S-TMC03	L5	L9
Tie rod cylinders	4MA standard sensor	1-1/2" - 5"	P8S-GPFAX	P8S-GPFDX	P8S-GPCHX	P8S-GPSCX	P8S-GPMHX	N/A	L5	N/A
	2MNR	1-1/2" - 4"						P8S-TMA0X	L5	N/A
	4MA	6" - 8"								
Iso cylinders	P1A standard sensor	10-25mm	P8S-GPFAX	P8S-GPFDX	P8S-GPCHX	P8S-GPSCX	P8S-GPMHX	P8S-TMC01	L5	L9
		10mm	P1A-2XMK <sup>1</sup>	N/A	N/A	N/A	N/A	P1A-2CCC	L13	L13
	P1A right angle sensors	12mm	P1A-2XMK <sup>1</sup>	N/A	N/A	N/A	N/A	P1A-2DCC	L13	L13
		16mm	P1A-2XMK <sup>1</sup>	N/A	N/A	N/A	N/A	P1A-2FCC	L13	L13
		20mm	P1A-2XMK <sup>1</sup>	N/A	N/A	N/A	N/A	P1A-2HCC	L13	L13
		25mm	P1A-2XMK <sup>1</sup>	N/A	N/A	N/A	N/A	P1A-2JCC	L13	L13
P1D standard & clean profiles	All	P8S-GPFAX	P8S-GPFDX	P8S-GPCHX	P8S-GPSCX	P8S-GPMHX	N/A	L5	N/A	
P1D tie rod version	All	P8S-GPFAX	P8S-GPFDX	P8S-GPCHX	P8S-GPSCX	P8S-GPMHX	P8S-TMA0X	L5	N/A	
Rodless cylinders	P1X	All	P8S-GPFAX	P8S-GPFDX	P8S-GPCHX	P8S-GPSCX	P8S-GPMHX	P8S-TMA0Y	L5	N/A
	P1Z	All	P8S-GPFAX	P8S-GPFDX	P8S-GPCHX	P8S-GPSCX	P8S-GPMHX	N/A	L5	N/A
	OSP-P	All	P8S-GPFAX	P8S-GPFDX	P8S-GPCHX	N/A	N/A	Included w/ sensor	L11	N/A
Guided cylinders	P5T	Flush mount	P8S-GPFAX	P8S-GPFDX	P8S-GPCHX	P8S-GPSCX	P8S-GPMHX	N/A	L5	N/A
		Right angle	N/A	P8S-SPETXD	P8S-SPTHXD	N/A	N/A	N/A	L10	N/A
	P5E	All	P8S-GPFAX	P8S-GPFTX	P8S-GPCHX	P8S-GPSCX	P8S-GPMHX	N/A	L5	N/A
	HB	All	P8S-GPFAX	P8S-GPFTX	P8S-GPCHX	P8S-GPSCX	P8S-GPMHX	N/A	L5	N/A
		20 - 25mm	P8S-GPFAX	P8S-GPFTX	P8S-GPCHX	P8S-GPSCX	P8S-GPMHX	P8S-TMC01	L5	L9
	P5L	32 - 63mm	P8S-GPFAX	P8S-GPFTX	P8S-GPCHX	P8S-GPSCX	P8S-GPMHX	P8S-TMC02	L5	L9
80 - 100mm		P8S-GPFAX	P8S-GPFTX	P8S-GPCHX	P8S-GPSCX	P8S-GPMHX	P8S-TMC03	L5	L9	
Rotary actuators	PV XR	Normally open	SMH-1P <sup>2</sup>	N/A	SMH-1PC	N/A	N/A	N/A	L19	N/A
		Normally closed	SMC-1P <sup>2</sup>	N/A	SMC-1PC	N/A	N/A	N/A	L19	N/A
	PRN(A)	All	N/A	N/A	N/A	N/A	N/A	N/A	N/A	N/A
	PTR	10, 15	SWH-1P <sup>3</sup>	N/A	SWH-1PC	N/A	N/A	Included w/ sensor	L21	N/A
		20, 25, 32	SWH-2P <sup>3</sup>	N/A	SWH-2PC	N/A	N/A	Included w/ sensor	L21	N/A

1. Flying leads are 2 meters in length  
 2. Flying leads are 1.5 meters in length  
 3. Flying leads are 1 meter in length

Note: See page L23 for Weld Immune Sensors.  
 \* See page L25 for cord sets.



For inventory, lead times, and kit lookup, visit [www.pdnplu.com](http://www.pdnplu.com)

**NPN Solid State Sensor Selection Guide**

Series	Bore size or type	3m flying leads	10m flying leads	8mm quick connect*	8mm quick connect w/ 1m lead*	12mm quick connect*	Bracket	Sensor page #	Bracket page #		
Compact cylinders	P1Q	12mm - 100mm	P8S-ENFXS <sup>1</sup>	N/A	P8S-ENSUS	N/A	N/A	N/A	N/A		
	LPM	9/16"	L076950000 <sup>2</sup>	N/A	L07695000C	N/A	N/A	N/A	L15	N/A	
		3/4" - 1-1/8"	L076960000 <sup>2</sup>	N/A	L07696000C	N/A	N/A	N/A	N/A	L15	N/A
		1-1/2" - 2"	L076970000 <sup>2</sup>	N/A	L07697000C	N/A	N/A	N/A	N/A	L15	N/A
		2-1/2" - 4"	L076980000 <sup>2</sup>	N/A	L07698000C	N/A	N/A	N/A	N/A	L15	N/A
Round body cylinders	SR/ SRG, SRM/SRDM	9/16" - 3/4"	P8S-GNFAX	P8S-GNFDX	P8S-GNCHX	P8S-GNSCX	P8S-GNMHX	P8S-TMC01	L5	L9	
	P	1-1/16" - 2-1/2"	P8S-GNFAX	P8S-GNFDX	P8S-GNCHX	P8S-GNSCX	P8S-GNMHX	P8S-TMC02	L5	L9	
		1-1/8" - 2-1/2"	P8S-GNFAX	P8S-GNFDX	P8S-GNCHX	P8S-GNSCX	P8S-GNMHX	P8S-TMC02	L5	L9	
		3" - 4"	P8S-GNFAX	P8S-GNFDX	P8S-GNCHX	P8S-GNSCX	P8S-GNMHX	P8S-TMC03	L5	L9	
Tie rod cylinders	4MA standard sensor	1-1/2" - 5"	P8S-GNFAX	P8S-GNFDX	P8S-GNCHX	P8S-GPNSCX	P8S-GNMHX	N/A	L5	N/A	
	2MNR	1-1/2" - 4"									
	4MA	6" - 8"					P8S-TMA0X	L5	N/A		
ISO cylinders	P1A standard sensor	10-25mm	P8S-GNFAX	P8S-GNFDX	P8S-GNCHX	P8S-GNSCX	P8S-GNMHX	P8S-TMC01	L5	L5	
	P1A right angle sensors	10mm bore	P1A-2XLK <sup>1</sup>	N/A	N/A	N/A	N/A	N/A	P1A-2CCC	L13	L13
		12mm bore	P1A-2XLK <sup>1</sup>	N/A	N/A	N/A	N/A	N/A	P1A-2DCC	L13	L13
		16mm bore	P1A-2XLK <sup>1</sup>	N/A	N/A	N/A	N/A	N/A	P1A-2FCC	L13	L13
		20mm bore	P1A-2XLK <sup>1</sup>	N/A	N/A	N/A	N/A	N/A	P1A-2HCC	L13	L13
		25mm bore	P1A-2XLK <sup>1</sup>	N/A	N/A	N/A	N/A	N/A	P1A-2JCC	L13	L13
P1D standard & clean profiles	All	P8S-GNFAX	P8S-GNFDX	P8S-GNCHX	P8S-GNSCX	P8S-GNMHX	N/A	L5	N/A		
P1D tie rod version	All	P8S-GNFAX	P8S-GNFDX	P8S-GNCHX	P8S-GNSCX	P8S-GNMHX	P8S-TMA0X	L5	N/A		
Rodless Cylinders	P1X	All	P8S-GNFAX	P8S-GNFDX	P8S-GNCHX	P8S-GNSCX	P8S-GNMHX	P8S-TMA0Y	L5	N/A	
	P1Z	All	P8S-GNFAX	P8S-GNFDX	P8S-GNCHX	P8S-GNSCX	P8S-GNMHX	N/A	L5	N/A	
	OSP-P	All	P8S-GNFAX	P8S-GNFDX	P8S-GNCHX	N/A	N/A	N/A	N/A	N/A	
Guided cylinders	P5T	Flush mount	P8S-GNFAX	P8S-GNFDX	P8S-GNCHX	P8S-GNSCX	P8S-GNMHX	N/A	L5	N/A	
		Right angle	N/A	P8S-SNETX	P8S-SNTHX	N/A	N/A	N/A	L10	N/A	
	P5E	All	P8S-GNFAX	P8S-GNFDX	P8S-GNCHX	P8S-GNSCX	P8S-GNMHX	N/A	L5	N/A	
	HB	All	P8S-GNFAX	P8S-GNFDX	P8S-GNCHX	P8S-GNSCX	P8S-GNMHX	N/A	L5	N/A	
		20 - 25mm	P8S-GNFAX	P8S-GNFDX	P8S-GNCHX	P8S-GNSCX	P8S-GNMHX	P8S-TMC01	L5	L9	
32 - 63mm		P8S-GNFAX	P8S-GNFDX	P8S-GNCHX	P8S-GNSCX	P8S-GNMHX	P8S-TMC02	L5	L9		
P5L	80 - 100mm	P8S-GNFAX	P8S-GNFDX	P8S-GNCHX	P8S-GNSCX	P8S-GNMHX	P8S-TMC03	L5	L9		
Rotary actuators	PV XR	Normally open	SMH-1N <sup>2</sup>	N/A	SMC-1NC	N/A	N/A	N/A	L19	N/A	
		Normally closed	SMC-1N <sup>2</sup>	N/A	SMC-1NC	N/A	N/A	N/A	L16	N/A	
	PRN(A)	All	See page L17								
	PTR	10, 15	SWH-1N <sup>3</sup>	N/A	SWH-1NC	N/A	N/A	Included w/ sensor	L21	N/A	
20, 25, 32		SWH-2N <sup>3</sup>	N/A	SWH-2NC	N/A	N/A	Included w/ sensor	L21	N/A		

1 Flying leads are 2 meters in length  
 2 Flying leads are 1.5 meters in length  
 3 Flying leads are 1 meter in length

Note: See page L23 for Weld Immune Sensors.  
 \* See page L25 for cord sets.

Selection Guide  
 Drop-in Sensors  
 Solid State / Reed Sensors  
 Weld Immune Sensors  
 Cordset / Connect Block  
 Proximity Sensors  
 Electronic Sensors



For inventory, lead time, and kit lookup, visit [www.pdnplu.com](http://www.pdnplu.com)

Selection Guide

Reed Sensor Selection Guide

Series	Bore size or type	3m flying leads	10m flying leads	8mm quick connect*	8 mm quick connect w/ 1 m lead*	12mm quick connect*	Bracket	Sensor page #	Bracket page #	
Compact cylinders	P1Q	12mm - 100mm	P8S-ERFXS <sup>1</sup>	N/A	P8S-ERSUS	N/A	N/A	N/A	N/A	
	LPM	9/16"	L077030000 <sup>1</sup>	N/A	L07703000C	N/A	N/A	N/A	L11	N/A
		3/4" - 1-1/8"	L077040000 <sup>1</sup>	N/A	L07704000C	N/A	N/A	N/A	L11	N/A
		1-1/2" - 2"	L077050000 <sup>1</sup>	N/A	L07705000C	N/A	N/A	N/A	L11	N/A
		2-1/2" - 4"	L077060000 <sup>1</sup>	N/A	L07706000C	N/A	N/A	N/A	L11	N/A
Round body cylinders	SR/ SRG, SRM/SRDM	9/16" - 3/4"	P8S-GRFAX	P8S-GRFDX	P8S-GRCHX	P8S-GRSCX	P8S-GRMHX	P8S-TMC01	L8	L9
	P	1-1/16" - 2-1/2"	P8S-GRFAX	P8S-GRFDX	P8S-GRCHX	P8S-GRSCX	P8S-GRMHX	P8S-TMC02	L8	L9
		1-1/8" - 2-1/2"	P8S-GRFAX	P8S-GRFDX	P8S-GRCHX	P8S-GRSCX	P8S-GRMHX	P8S-TMC02	L8	L9
		3" - 4"	P8S-GRFAX	P8S-GRFDX	P8S-GRCHX	P8S-GRSCX	P8S-GRMHX	P8S-TMC03	L8	L9
Tie rod cylinders	4MA standard sensor	1-1/2" - 5"	P8S-GRFAX	P8S-GRFDX	P8S-GRCHX	P8S-GRSCX	P8S-GRMHX	N/A	L8	N/A
	2MNR	1-1/2 - 4"						P8S-TMAOX	L4	N/A
	4MA	6" - 8"								
ISO cylinders	P1A standard sensor	10-25mm	P8S-GRFAX	P8S-GRFDX	P8S-GRCHX	P8S-GRSCX	P8S-GRMHX	P8S-TMC01	L4	L9
	P1A alternate sensors	10mm bore	P1A-2XRL	N/A	P1A-2XSH	N/A	N/A	P1A-2CCB	L13	L13
		12mm bore	P1A-2XRL	N/A	P1A-2XSH	N/A	N/A	P1A-2DCB	L13	L13
		16mm bore	P1A-2XRL	N/A	P1A-2XSH	N/A	N/A	P1A-2FCB	L13	L13
		20mm bore	P1A-2XRL	N/A	P1A-2XSH	N/A	N/A	P1A-2HCB	L13	L13
		25mm bore	P1A-2XRL	N/A	P1A-2XSH	N/A	N/A	P1A-2JCB	L13	L13
P1D standard & clean profiles	All	P8S-GRFAX	P8S-GRFDX	P8S-GRCHX	P8S-GRSCX	P8S-GRMHX	N/A	L8	N/A	
	All	P8S-GRFAX	P8S-GRFDX	P8S-GRCHX	P8S-GRSCX	P8S-GRMHX	P8S-TMAOX	L8	N/A	
Rodless cylinders	P1X	All	P8S-GRFAX	P8S-GRFDX	P8S-GRCHX	P8S-GRSCX	P8S-GRMHX	P8S-TMAOY	L8	N/A
	P1Z	All	P8S-GRFAX	P8S-GRFDX	P8S-GRCHX	P8S-GRSCX	P8S-GRMHX	N/A	L8	N/A
	OSP-P	All	P8S-GRCHX	P8S-GRFDX	P8S-GRCHX	N/A	N/A	Included w/ sensor	L8	N/A
Guided cylinders	P5T	Flush mount	P8S-GRFLX	P8S-GRFDX	P8S-GRCHX	P8S-GRSCX	P8S-GRMHX	N/A	L8	N/A
		Right angle	N/A	P8S-SRETX	P8S-SRTHX	N/A	N/A	N/A	L8	N/A
	P5E	All	P8S-GRFAX	P8S-GRFDX	P8S-GRCHX	P8S-GRSCX	P8S-GRMHX	N/A	L8	N/A
	HB	All	P8S-GRFAX	P8S-GRFDX	P8S-GRCHX	P8S-GRSCX	P8S-GRMHX	N/A	L8	N/A
		20 - 25mm	P8S-GRFAX	P8S-GRFDX	P8S-GRCHX	P8S-GRSCX	P8S-GRMHX	P8S-TMC01	L8	L8
		32 - 63mm	P8S-GRFAX	P8S-GRFDX	P8S-GRCHX	P8S-GRSCX	P8S-GRMHX	P8S-TMC02	L8	L8
P5L	80 - 100mm	P8S-GRFAX	P8S-GRFDX	P8S-GRCHX	P8S-GRSCX	P8S-GRMHX	P8S-TMC03	L8	L8	
	Rotary actuators	N.O. high amp	SMR-1 <sup>1</sup>	N/A	SMR-1C	N/A	N/A	N/A	L19	N/A
N.O. low amp		SMR-1L <sup>1</sup>	N/A	SMR-1LC	N/A	N/A	N/A	L19	N/A	
N.C.		SMD-1L <sup>1</sup>	N/A	SMD-1LC	N/A	N/A	N/A	L19	N/A	
PRN	50 - 800	See model code						L18	N/A	
PTR	10, 15	SWR-1 <sup>2</sup>	N/A	SWR-1C	N/A	N/A	Included w/ sensor	L21	N/A	
	20, 25, 32	SWR-2 <sup>2</sup>	N/A	SWR-2C	N/A	N/A	Included w/ sensor	L21	N/A	

1. Flying leads are 1.5 meters in length  
2. Flying leads are 1 meters in length

Note: See page L23 for Weld Immune Sensors.  
\* See page L25 for cord sets.



For inventory, lead times, and kit lookup, visit [www.pdnplu.com](http://www.pdnplu.com)



## P8S Global Drop-In Solid State Sensors



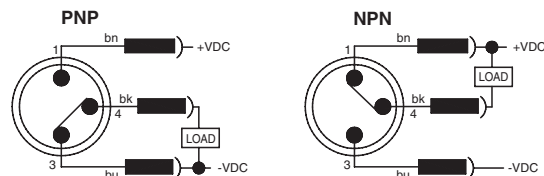
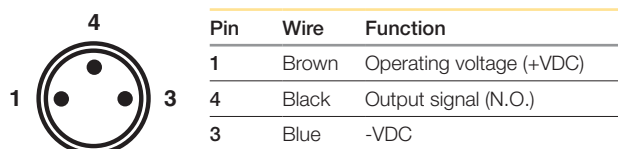
Wiring	PNP sensor	NPN sensor	PNP sensor ATEX certified
3m flying leads	<b>P8S-GPFAX</b>	<b>P8S-GNFAX</b>	<b>P8S-GPFLX/EX</b>
10m flying leads	<b>P8S-GPFDX</b>	<b>P8S-GNFDX</b>	N/A
0.3m lead with 8mm connector	<b>P8S-GPCHX</b>	<b>P8S-GNCHX</b>	
0.3m lead with 12mm connector	<b>P8S-GPMHX</b>	<b>P8S-GNMHX</b>	
1m lead with 8mm connector	<b>P8S-GPSCX</b>	<b>P8S-GNSCX</b>	

### Specifications

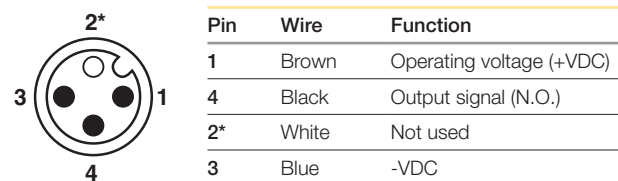
Switch classification	Standard PNP or NPN	ATEX certified PNP
Type	Electronic	
Output function	Normally open	
Sensor output	PNP/NPN	PNP
Operating voltage	10 - 30 VDC	10 - 30 VDC
Continuous current	100 mA max.	70 mA max.
Response sensitivity	28 Gauss min.	
Switching frequency	1 KHz	
Power consumption	10 mA max.	
Voltage drop	2.5 VDC max.	
Ripple	10% of operating voltage	
Hysteresis	1.5 mm max.	
Repeatability	0.1 mm max.	
EMC	EN 60 947-5-2	
Short-circuit protection	Yes	
Power-up pulse suppression	Yes	
Reverse polarity protection	Yes	
Enclosure rating	IP68	
Shock and vibration stress	30g, 11 ms, 10 to 55 Hz, 1mm	
Operating temperature range	-25°C to 75°C (-13°F to 167°F)	-20°C to 45°C (-4°F to 113°F)
Housing material	PA 12, black	
Connector cable	PVC	
Connector	PUR	—
Approval for ATEX	—	3D/3G

### Wiring connection

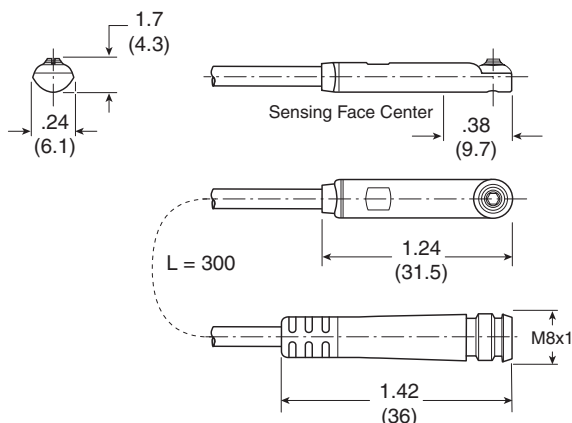
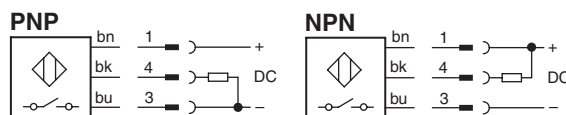
#### Flying lead or 8 mm connector (shown)



#### 12 mm connector



\* Pin 2 not present.



For inventory, lead time, and kit lookup, visit [www.pdnplu.com](http://www.pdnplu.com)

Selection Guide  
 Drop-in Sensors  
 Solid State / Reed Sensors  
 Weld Immune Sensors  
 Cordset / Connect Block  
 Proximity Sensors  
 Electronic Sensors

## P8S Global Drop-In Reed Sensors



Wiring	Reed sensor
3m flying leads	<b>P8S-GRFAX</b>
10m flying leads	<b>P8S-GRFDX</b>
10m flying leads	<b>P8S-GRFDX2*</b>
0.3m lead with 8mm connector	<b>P8S-GRCHX</b>
0.3m lead with 12mm connector	<b>P8S-GRMHX</b>
1m lead with 8mm connector	<b>P8S-GRSCX</b>

### Specifications

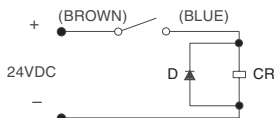
Type	2-wire reed
Output function	Normally open
Operating voltage	10 - 30 VAC*, 10 - 30 VDC
Switching power	6 W/VA
Continuous current	100 mA max.
Response sensitivity	30 Gauss min.
Switching frequency	400 Hz
Voltage drop	2.5 V max.
Ripple	10% of operating voltage
Hysteresis	1.5 mm max.
Repeatability	0.2 mm max.
EMC	EN 60 947-5-2
Reverse polarity protection	Yes
Enclosure rating	IP68
Shock and vibration stress	30g, 11 ms, 10 to 55 Hz, 1 mm
Operating temperature range	-25°C to 75°C (-13°F to 167°F)
Housing material	PA 12, black
Connector cable	PVC
Connector	PUR cable with 8 or 12 mm connector

\* 10-230 VAC/DC for P8S-GRFDX2.

### Circuit for switching contact protection (for inductive loads, e.g. solenoids, relays)

#### (Required for proper operation 24VDC)

Put diode parallel to load (CR) following polarity as shown.

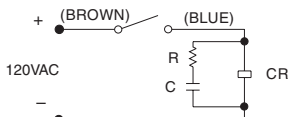


D: Diode: select a diode with the breakdown voltage and current rating according to the load.

**Typical Example – 100 volt, 1 amp diode**  
 CR: Relay coil (under 0.5W coil rating)

#### (Recommended for longer life 120 VAC)

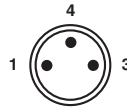
Put a resistor and capacitor in parallel with the load (CR). Select the resistor and capacitor according to the load.



**Typical Example:**  
 CR: Relay coil (under 2W coil rating)  
 R: Resistor 1 KΩ - 5 KΩ, 1/4 W  
 C: Capacitor 0.1 μF, 600 V

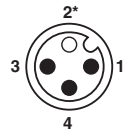
### Wiring connection

#### Flying Lead or 8 mm Connector



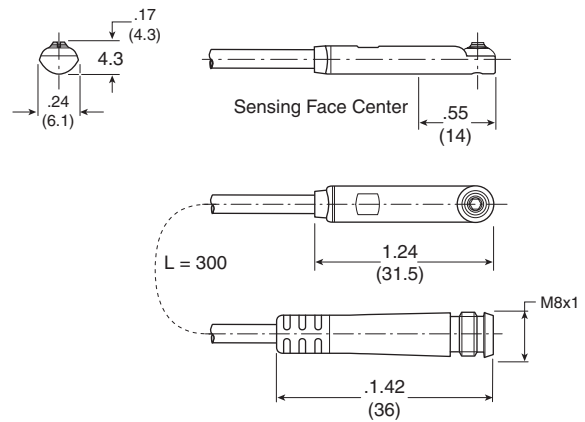
Pin	Wire	Function
1	Brown	Operating voltage (+V)
4	Black	Not used
3	Blue	Output signal (-V or ground)

#### 12 mm Connector



Pin	Wire	Function
1	Brown	Operating voltage (+V)
2*	White	Not used
3	Blue	Output signal (-V or ground)
4	Black	Not used

\* Pin 2 not present.



#### ⚠ Caution

- Use an ammeter to test reed sensor current. Testing devices such as incandescent light bulbs may subject the reed sensor to high in-rush loads.
- **NOTE:** When checking an unpowered reed sensor for continuity with a digital ohmmeter the resistance reading will change from infinity to a very large resistance (2 M ohm) when the sensor is activated. This is due to the presence of a diode in the reed sensor.
- Anti-magnetic shielding is recommended for reed sensors exposed to high external RF or magnetic fields.
- The magnetic field strength of the piston magnet is designed to operate with our sensors. Other manufacturers' sensors may not operate correctly in conjunction with these magnets.
- Use relay coils for reed sensor contact protection.
- The operation of some 120 VAC PLC's (especially some older Allen-Bradley PLC's) can overload the reed sensor. The sensor may fail to release after the piston magnet has passed. This problem may be corrected by the placement of a 700 to 1K OHM resistor between the sensor and the PLC input terminal. Consult the manufacturer of the PLC for appropriate circuit.
- Sensors with long wire leads (greater than 15 feet) can cause capacitance build-up and sticking will result. Attach a resistor in series with the reed sensor (the resistor should be installed as close as possible to the sensor). The resistor should be selected such that  $R \text{ (ohms)} > E/0.3$ .



For inventory, lead times, and kit lookup, visit [www.pdnplu.com](http://www.pdnplu.com)

## P8S Mini-Global Drop-In Solid State Sensors

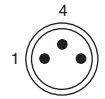


Wiring	PNP Sensor	NPN Sensor
3m Flying Leads	<b>P8S-MPFLY</b>	<b>P8S-MNFLY</b>
10m Flying Leads	<b>P8S-MPFTX</b>	<b>P8S-MNFTX</b>
0.3m Lead with 8mm Connector	<b>P8S-MPSHX</b>	<b>P8S-MNSHX</b>

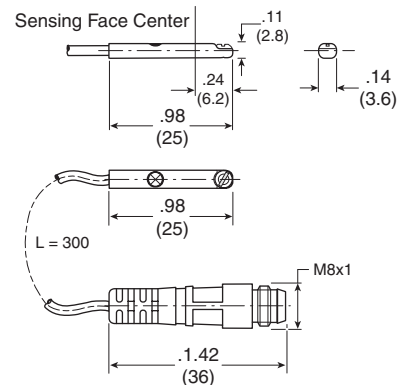
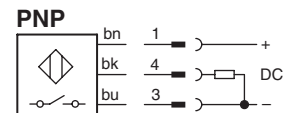
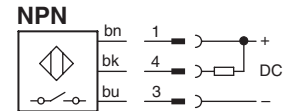
### Specifications

Type	Electronic
Output Function	Normally open
Sensor Output	PNP or NPN
Operating Voltage	10 - 30 VDC
Continuous Current	≤ 70 mA
Response Sensitivity	≤ 48 Gauss
Switching Frequency	1000 Hz
Power Consumption	≤ 8 mA without load
Voltage Drop	≤ 2.5 VDC
Ripple	10% of operating voltage
Hysteresis	≤ 15 Gauss
Repeatability	≤ ±0.1 mm
EMC	EN 60 947-5-2
Short-circuit Protection	Yes
Power-up Pulse Suppression	No
Reverse Polarity Protection	Yes
Enclosure Rating	IP67
Shock and Vibration Stress	30g, 11 ms, 10 to 55 Hz, 1 mm
Operating Temperature Range	-25°C to 75°C (-13°F to 167°F)
Housing Material	PA 12
Connector Cable	PUR 3 x 0.09mm <sup>2</sup>
Connector	PUR cable w/8mm connector

### Wiring connection



Pin	Wire	Function
1	Brown	+VDC
4	Black	NO
3	Blue	-VDC



Selection Guide

Drop-in Sensors

Solid State / Reed Sensors

Weld Immune Sensors

Cordset / Connect Block

Proximity Sensors

Electronic Sensors



For inventory, lead time, and kit lookup, visit [www.pdnplu.com](http://www.pdnplu.com)

L7

**Parker Hannifin Corporation**  
 Pneumatic Division  
 Richland, Michigan  
[www.parker.com/pneumatics](http://www.parker.com/pneumatics)

P8S Mini-Global Drop-In Reed Sensors

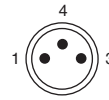


Wiring	Reed Sensor
3m Flying Leads	<b>P8S-MRFLY</b>
10m Flying Leads	<b>P8S-MRFTX</b>
0.3m Lead with 8mm Connector	<b>P8S-MRSHX</b>

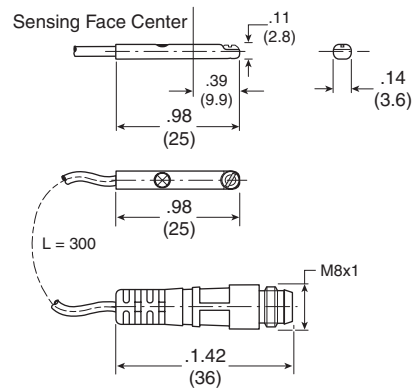
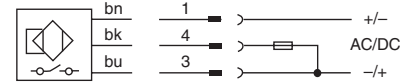
Specifications

Type	3-Wire Reed
Output Function	Normally Open
Operating Voltage	10 - 30 VAC, 10 - 30 VDC
Switching Power	10 W/VA
Continuous Current	≤ 500 mA max.
Response Sensitivity	≤ 48 Gauss
Switching Frequency	500 Hz
Hysteresis	≤ 7 Gauss
Repeatability	≤ 0.1 mm
EMC	EN 60 947-5-2 / EN 40 050
Enclosure Rating	IP67
Shock and Vibration Stress	30g, 11 ms, 10 to 55 Hz, 1 mm
Operating Temperature Range	-25°C to 75°C (-13°F to 167°F)
Housing Material	PA 12
Connector Cable	PUR 3 x 0.09 mm <sup>2</sup>
Connector	PUR cable w/8mm connector

Wiring connection



Pin	Wire	Function
1	Brown	Operating voltage (+V)
4	Black	Output signal
3	Blue	Ground (-V)



**Caution**

- Use an ampmeter to test reed sensor current. Testing devices such as incandescent light bulbs may subject the reed sensor to high in-rush loads.
- NOTE: When checking an unpowered reed sensor for continuity with a digital ohmmeter the resistance reading will change from infinity to a very large resistance (2 M ohm) when the sensor is activated. This is due to the presence of a diode in the reed sensor.
- Anti-magnetic shielding is recommended for reed sensors exposed to high external RF or magnetic fields.
- The magnetic field strength of the piston magnet is designed to operate with our sensors. Other manufacturers' sensors may not operate correctly in conjunction with these magnets.
- Use relay coils for reed sensor contact protection.
- The operation of some 120 VAC PLC's (especially some older Allen-Bradley PLC's) can overload the reed sensor. The sensor may fail to release after the piston magnet has passed. This problem may be corrected by the placement of a 700 to 1K OHM resistor between the sensor and the PLC input terminal. Consult the manufacturer of the PLC for appropriate circuit.
- Sensors with long wire leads (greater than 15 feet) can cause capacitance build-up and sticking will result. Attach a resistor in series with the reed sensor (the resistor should be installed as close as possible to the sensor). The resistor should be selected such that R (ohms) >E/0.3.



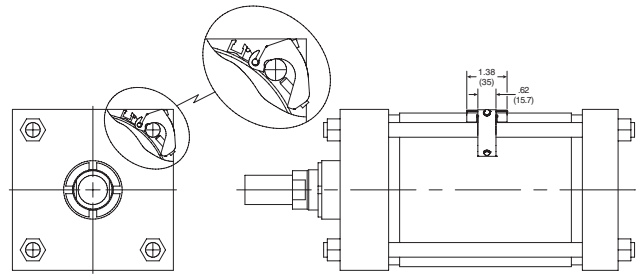
For inventory, lead times, and kit lookup, visit [www.pdnplu.com](http://www.pdnplu.com)

## Tie Rod Bracket Assembly

Tie Rod Bracket Assembly is necessary for Global and Mini-Global Sensor installation on all tie rod construction cylinders. This includes all Intermediate Trunnion mounts (Style DD or MT4); and all 6"-8" bore Sensors and bracket assemblies must be ordered separately.

Part number P8S-TMAOX fits 1-1/2" to 8" bores and 32-200mm bores for Global Sensors

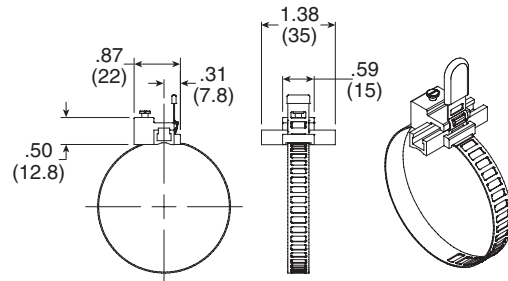
P8S-TMAOX



## Round Body Bracket Assembly

Sensors and brackets must be ordered separately

Bore size	Round body bracket
9/16" - 1-1/16"	<b>P8S-TMC01</b>
20 - 25mm	<b>P8S-TMC01</b>
1-1/8" - 2-1/2"	<b>P8S-TMC02</b>
32 - 63mm	<b>P8S-TMC02</b>
3" - 4"	<b>P8S-TMC03</b>
80 - 100mm	<b>P8S-TMC03</b>



Selection Guide
Drop-in Sensors
Solid State / Reed Sensors
Weld Immune Sensors
Cordset / Connect Block
Proximity Sensors
Electronic Sensors



For inventory, lead time, and kit lookup, visit [www.pdnplu.com](http://www.pdnplu.com)

## Right Angle Sensors

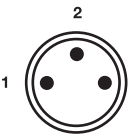
### Solid State – P8S Right Angle Sensors

#### Specifications

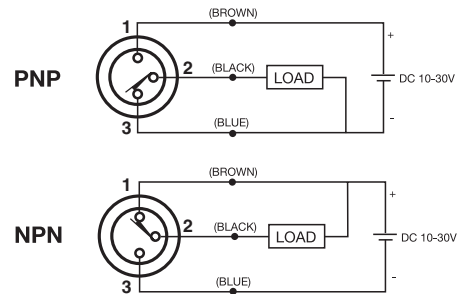
Type	Electronic
Output function	Normally open
Switching output	PNP/NPN
Operating voltage	10 - 30 VDC
Continuous current	≤ 150 mA
Response sensitivity	30 Gauss min.
Switching frequency	5kHz
Power consumption	15 mA
Voltage drop	≤ 2 VDC
Ripple	≤ 10% of operating voltage
Delay time (24V)	Approx. 20 ms
Time delay before availability	≤ 2 ms
Hysteresis	≤ 1.5mm
Repeatability	≤ 0.2mm
EMC	EN 60 947-5-2
Short-circuit protection	Yes
Power-up pulse suppression	Yes
Reverse polarity protection	Yes
Enclosure rating	IP67 DIN 40050
Shock and vibration stress	30g, 11ms, 10 to 55 Hz, 1mm
Ambient temperature range	-25°C to 75°C (-13°F to 167°F)
Housing material	PA 12, black
Connector cable	PVC
Connector	PUR cable w/8 mm connector

Wiring	PNP sensors	NPN sensors
0.2m lead with 8mm connector	<b>P8S-SPTHXD</b>	<b>P8S-SNTHX</b>
10m flying leads	<b>P8S-SPETXD</b>	<b>P8S-SNETX</b>

#### Wiring connection



Pin	Wire	Function
1	Brown	Operating voltage (+VDC)
2	Black	Output signal (N.O.)
3	Blue	-VDC



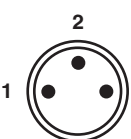
### Reed – P8S Right Angle Sensors

#### Specifications

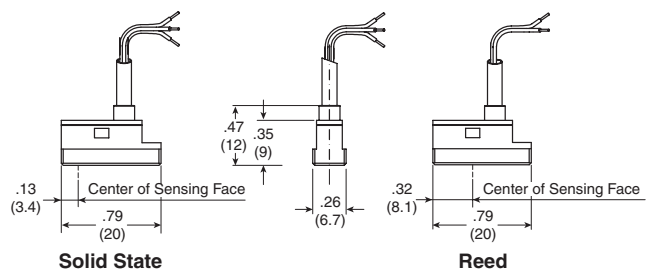
Type	2-wire reed
Output function	Normally open
Output voltage	10 - 110* VAC, 10 - 30 VDC
Continuous current	≤ 100 mA
Response sensitivity	30 Gauss min.
Switching frequency	400 Hz
Voltage drop	≤ 3 V
Ripple	≤ 10% of operating voltage
Time delay (24V)	Approx. 20 ms
Hysteresis	≤ 1.0mm
Repeatability	≤ 0.2mm
EMC	EN 60 947-5-2
Reverse polarity protection	Yes
Enclosure rating	IP67
Shock and vibration stress	30g, 11ms, 10 to 55 Hz, 1mm
Ambient temperature range	-25°C to 75°C (-13°F to 167°F)
Housing material	PA 12, black
Connector cable	PVC
Connector	PUR cable w/8 mm connector

Wiring	Reed sensors
0.2m lead with 8mm connector	<b>P8S-SRTHX</b>
10m flying leads	<b>P8S-SRETX</b>

#### Wiring connection



Pin	Wire	Function
1	Brown	Operating voltage (+V)
3	Black	Not used
2	Blue	Output signal (-V or Ground)



\* 8mm connector rated for 50 VAC max.



For inventory, lead times, and kit lookup, visit [www.pdnplu.com](http://www.pdnplu.com)

**OSP-P Magnetic Switches**

**OSP-P Magnetic Switches for T-Slot – Series RST & EST**

Magnetic switches are used for electrical sensing of the position of the piston, e.g. at its end positions. They can also be used for sensing of intermediate positions.

Sensing is contactless, based on magnets which are built-in as standard. A yellow LED indicates operating status.

The universal magnetic switches are suitable for all OSP-P Actuators.

1) For the magnetic switch temperature range, please take into account the surface temperature and the self-heating properties of the linear drive.



**Characteristics**

Electrical characteristics	Unit	Type RST	Type EST
Switching output		Reed	PNP
Operating voltage	V	10-30 AC/DC	10-30 DC
Ripple		—	≤ 10%
Voltage drop	V	≤ 3	≤ 2
Electrical configuration		Two wire	Three wire
Output function		normally open normally closed	normally open
Permanent current	mA	≤ 100	≤ 100
Breaking capacity	W	≤ 6 peak	—
Power consumption at UB = 24V, switched on, without load	mA	—	≤ 10
Function indicator		LED, yellow (not for normally closed)	
Response time	ms	≤ 2	≤ 0.5
Sensitivity	mT	2 – 4	2 – 4
Time delay before availability	ms	—	≤ 2
Reverse polarity protection		Yes	Yes
Short-circuit protection		No	Yes (pulsed)
Switchable capacity load	µF	0.1 at 100 W, 24 VDC	
Switching frequency	Hz	≤ 400	≤ 5k
Repeatability	mm	≤ 0.2	≤ 0.2
Hysteresis	mm	≤ 1.5	≤ 1.5
EMC	EN	60947-5-2	
Lifetime		≥ 35 Mio. cycles with PLC load	Unlimited
Power-up pulse suppression		—	Yes
Protection for inductive load		—	Yes
Mechanical characteristics	Unit	Type RST	Type EST
Housing		Plastic / PA66 + PA6I red	
Cable cross section	mm <sup>2</sup>	2 x 0.14	3 x 0.14
Cable type*		PUR, black	PUR, black
Bending radius	mm	≥ 36	≥ 30
Weight (Mass)	kg	ca. 0.030 RST-K ca. 0.010 RST-S	ca. 0.030 EST-K ca. 0.010 EST-S
Degree of protection	IP	67 to DIN EN 60529	
Ambient temperature range**	°C	-25°C to 80°C	-25°C to 75°C at UB=10 – 30 V -25°C to 80°C at UB=10 – 28 V
– with adapter	°C	-25°C to 60°C	
Adapter tightening torque	Nm	0.15 (tightening torque of screwing adapter onto magnetic switch)	
Shock resistance			
Vibration to EN 60068-2-6	G	15, 11 ms, 10 to 55 Hz, 1mm	
Shock to EN 60068-2-27	G	50, 11 ms	
Bump to EN 60068-2-29	G	30, 11 ms, 1000 bumps each axis	

Selection Guide  
Drop-in Sensors  
Solid State / Reed Sensors  
Weld Immune Sensors  
Cordset / Connect Block  
Proximity Sensors  
Electronic Sensors



For inventory, lead time, and kit lookup, visit [www.pdnplu.com](http://www.pdnplu.com)

**Magnetic Switches**

**Ordering Information**

Version	Voltage	Type	Part number
Magnetic switch, reed contact, normally open, LED indicator, cable 3m	10-30 VAC / VDC	<b>RST-K</b>	<b>P8S-GRFAX</b>
Magnetic switch, reed contact, normally open, LED indicator, cable 10m	10-30 VAC / VDC	<b>RST-K</b>	<b>P8S-GRFDX</b>
Magnetic switch, reed contact, normally open, LED indicator, cable 10m	10-230 VAC / VDC	<b>RST-K</b>	<b>P8S-GRFDX2</b>
Magnetic switch, reed contact, normally open, snap connector M8, LED indicator, cable 0.24m	10-30 VAC / VDC	<b>RST-S</b>	<b>P8S-GRCHX</b>
Magnetic switch, reed contact, normally open, screw connector M8, LED indicator, cable 0.24m	10-30 VAC / VDC	<b>RST-S</b>	<b>P8S-GRCHX</b>
Magnetic switch, reed contact, normally closed, cable 10m	10-30 VAC / VDC	<b>RST-K</b>	<b>P8S-GEFRX</b>
Magnetic switch, electronic, PNP LED indicator, cable 3m	10-30 VDC	<b>EST-K</b>	<b>P8S-GPFAX</b>
Magnetic switch, electronic, PNP LED indicator, cable 10m	10-30 VDC	<b>EST-K</b>	<b>P8S-GPFDX</b>
Magnetic switch, electronic, PNP M8, LED indicator, cable 0.24m	10-30 VDC	<b>EST-S</b>	<b>P8S-GPCHX</b>
Magnetic switch, electronic, NPN M8, LED indicator, cable 0.24m	10-30 VDC	<b>EST-S</b>	<b>P8S-GNCHX</b>
Included in delivery: 1 magnetic switch 1 adapter for dovetail groove mounting			

**Accessories**

Description	Type	Part number
Cable M8, 2.5m without lock nut	<b>KS 25</b>	<b>KY3240</b>
Cable M8, 5.0m without lock nut	<b>KS 50</b>	<b>KY3241</b>
Cable M8, 5.0m without lock nut	<b>ES-S / RS-S</b>	<b>4041</b>
Cable M8, 5.0m with lock nut	<b>KSG 50</b>	<b>KC3104</b>
Adapter for dovetail groove (pack of 10)		<b>KL3333</b>



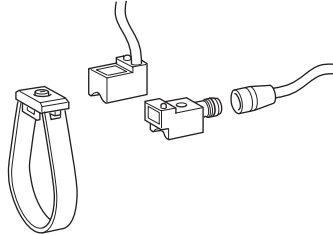
For inventory, lead times, and kit lookup, visit [www.pdnplu.com](http://www.pdnplu.com)

Selection Guide  
 Drop-in Sensors  
 Solid State / Reed Sensors  
 Weld Immune Sensors  
 Cordset / Connect Block  
 Proximity Sensors  
 Electronic Sensors



**P1A Series Solid State Sensors**

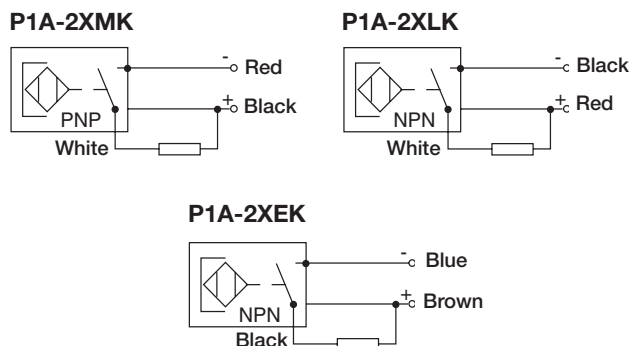
These sensors are of solid-state type, with no moving parts. Short-circuit and transient protection is incorporated as standard. The integral electronics make these sensors suitable for applications with very high switching frequencies.



**Specifications**

Design	Hall element
Output	PNP resp. NPN, N.O.
Voltage range	10-30 VDC
Max permissible ripple	10%
Max voltage drop	0.5 V at 100 mA
Max load current, P1A-2XMK, LK	150 mA
P1A-2XHK, EK, JH, FH	100 mA
Max breaking power (resistive)	6 W
Internal consumption	<30 mA at 30 V
Min actuating distance	5 mm
Hysteresis	1.1 - 1.3mm
Repeatability accuracy	±0.1mm
Max on/off switching frequency	1 kHz
Max on/off switching time	0.8/3.0 ms
Encapsulation, P1A-2XHK, EK, MK, LK	IP67
Temperature range	-10 °C to 60 °C (14°F to 140°F)
Indication	LED
Shock resistance	40 g
Material, housing	Polyamid 11
Material, mould	Epoxy
Cable	PVC 3x0.15 mm <sup>2</sup>
Cable incl. female part connector	PVC 3x0.15 mm <sup>2</sup>
Connector	8mm snap on
Mounting	Mounting yoke
Material, mounting	Acetal/Stainless steel
Material, screw	Stainless steel

**Wiring connection**



**Electronic Sensors**

Output	Cable length	Weight (lb)	Part number
PNP, N.O.	2m	0.09	<b>P1A-2XMK, Rt. angle</b>
NPN, N.O.	2m	0.09	<b>P1A-2XLK, Rt. angle</b>
NPN, N.O.	2m	0.022	<b>P1A-2XEK</b>

**Mounting Brackets**

Fits cylinder bore size	Weight (lb)	Part number
10mm	0.01	<b>P1A-2CCC</b>
12mm	0.01	<b>P1A-2DCC</b>
16mm	0.0176	<b>P1A-2FCC</b>
20mm	0.0176	<b>P1A-2HCC</b>
25mm	0.022	<b>P1A-2JCC</b>

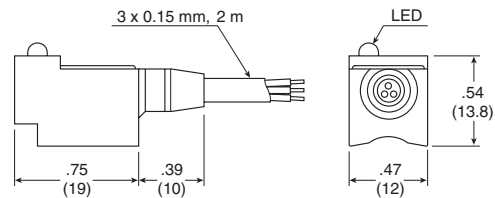
**Cable for Sensors**

Cable length	Weight (lb)	Part number
3m	0.12	<b>9126344341**</b>
10m	0.4	<b>9126344342**</b>

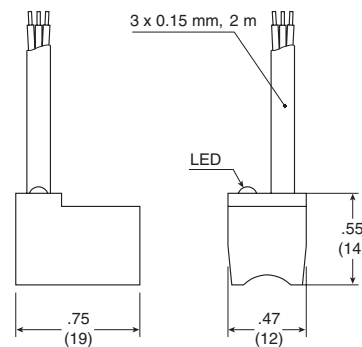
\* Cable ordered separately

\*\* Cable includes female part connector for sensor

**P1A-2XHK and P1A-2XEK**



**P1A-2XMK and P1A-2XLK**



Selection Guide

Drop-in Sensors

Solid State / Reed Sensors

Weld Immune Sensors

Cordset / Connect Block

Proximity Sensors

Electronic Sensors



For inventory, lead time, and kit lookup, visit [www.pdnplu.com](http://www.pdnplu.com)

LP/LPM Series Sensors

Bore size	Reed (Low AMP)	NPN sinking	PNP sourcing
9/16"	L077030000	L076950000	L076990000
3/4", 1-1/8"	L077040000	L076960000	L077000000
1-1/2", 2"	L077050000	L076970000	L077010000
2-1/2", 3", 4"	L077060000	L076980000	L077020000

Note: For sensors with an 8mm connector, replace the last digit with a 'C'. For example: L07696000C.

Selection Guide

Drop-in Sensors

Solid State / Reed Sensors

Weld Immune Sensors

Cordset / Connect Block

Proximity Sensors

Electronic Sensors

Solid State Sensors (NPN/PNP)

Switching Logic	N.O. NPN (Sinking) N.O. PNP (Sourcing)
Supply Voltage Range	5 - 30 VDC
On-State Voltage Drop	1.5 V max. at 100 mA
Current Output Range	100 mA
Burden Current	7 mA at 12 V 14 mA at 24 V
Leakage Current	0.01 mA
LED Function	NPN: Red (Target Present) PNP: Green (Target Present)
Minimum Current to Light LED	1 mA
Operating Temperature	14° to 158°F (-10° to 70°C)
Storage Temperature	-4° to 176°F (-20° to 80°C)
Enclosure Protection	IEC standard IP 67 NEMA 6P
Lead Wire	3 conductor, 24 gauge
Lead Wire Length	59 inches, 1.5 meter
Color of Cable	Black
Switching Response	Max. 1k Hz
Shock Resistance	50 G (490 m/s <sup>2</sup> )
Vibration Resistance	Double Amplitude 1.5 mm (Frequency 10 to 55 Hz 1 scanning, 1 minute)

Reed Sensor (Low AMP)

Switching Logic	N.O. SPST (Form A)
Supply Voltage Range	3 - 125 V AC/DC
On-State Voltage Drop	1.8V max. at 20 mA DC
Power Rating*	5 W (2.5 W) 5 VA (2.5 VA)
Switching Current Range*	5-40 mA (5-20 mA)
Leakage Current	0
LED Function	Red (Target Present)
Minimum Current to Light LED	3 mA
Operating Temperature	14° to 158°F (-10° to 70°C)
Storage Temperature	-4° to 176°F (-20° to 80°C)
Enclosure Protection	IEC standard IP67 NEMA 6P
Lead Wire	2 conductor, 24 gauge
Lead Wire Length	59 inches, 1.5 meter
Color of Cable	Gray
Switching Response	Max. 300 Hz
Shock Resistance	30 G (300 m/s <sup>2</sup> )
Vibration Resistance	Double Amplitude 1.5 mm (Frequency 10 to 55 Hz 1 scanning, 1 minute)

\* Number in parentheses pertains to inductive loads.

Circuits

NPN Sensor – Sinking Output

Color of Cable – Black  
"On" State Voltage Drop – 1.5V Maximum



PNP Sensor – Sourcing Output

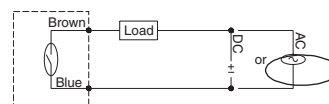
Color of Cable – Black  
"On" State Voltage Drop – 1.5V Maximum



\* Wire colors in parentheses pertain to sensors manufactured before 10/15/93.

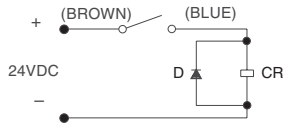
Reed Sensor

NOTE: Polarity must be observed for DC operation only.



**Circuit for Switching Contact Protection (Inductive Loads) – for Reed Sensor Only  
(Required for proper operation 24VDC)**

Put Diode parallel to load (CR) following polarity as shown below.

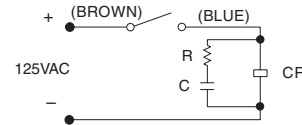


D: Diode: select a Diode with the breakdown voltage and current rating according to the load.

**Typical Example** – 100 Volt, 1 Amp Diode  
CR: Relay coil (under 0.5W coil rating)

(Recommended for longer life 125 VAC)

Put a resistor and capacitor in parallel with the load (CR). Select the resistor and capacitor according to the load.



**Typical Example:**

CR: Relay coil (under 2W coil rating)  
R: Resistor 1 KΩ – 5 KΩ, 1/4 W  
C: Capacitor 0.1 μF, 600 V

**⚠ Caution**

- Use an ampmeter to test reed sensor current. Testing devices such as incandescent light bulbs may subject the reed sensor to high in-rush loads.
- NOTE: When checking an unpowered reed sensor for continuity with a digital ohmmeter the resistance reading will change from infinity to a very large resistance (2 M ohm) when the sensor is activated. This is due to the presence of a diode in the reed sensor.
- Anti-magnetic shielding is recommended for reed sensors exposed to high external RF or magnetic fields.
- The magnetic field strength of the piston magnet is designed to operate with our sensors. Other manufacturers' sensors may not operate correctly in conjunction with these magnets.
- Current capabilities are relative to operational temperatures.
- Use relay coils for reed sensor contact protection.
- The operation of some 120 VAC PLC's (especially some older Allen-Bradley PLC's) can overload the reed sensor. The sensor may fail to release after the piston magnet has passed. This problem may be corrected by the placement of a 700 to 1K OHM resistor between the sensor and the PLC input terminal. Consult the manufacturer of the PLC for appropriate circuit.
- Sensors with long wire leads (greater than 15 feet) can cause capacitance build-up and sticking will result. Attach a resistor in series with the reed sensor (the resistor should be installed as close as possible to the sensor). The resistor should be selected such that  $R \text{ (ohms)} > E/0.3$ .

Selection Guide
Drop-in Sensors
Solid State / Reed Sensors
Weld Immune Sensors
Cordset / Connect Block
Proximity Sensors
Electronic Sensors



For inventory, lead time, and kit lookup, visit [www.pdnplu.com](http://www.pdnplu.com)

## PRNA Sizes 3 to 30 Sensors

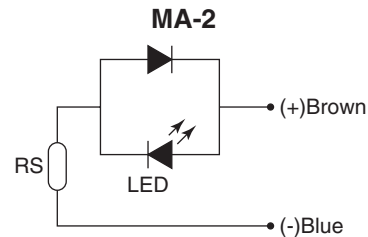
### Fixed Position Sensor

#### Specifications

Part Number	See Ordering Information
Type of Sensor	Solid State
Application	Relay, PLC, IC Circuit
Output Method	NPN
Load Voltage	5 to 30VDC
Load Current	5 to 200 mA
Max. Power Consumption of Switch Control	Max. 200 mA at 24V
Max. Leak Current	Max. 10 $\mu$ A
Internal Voltage Drop	1.5VDC or Less
Mean Response Time	1 ms
Shock Resistance	490 m/s <sup>2</sup>
Ambient Temperature	5 to 60°C
Enclosure Rating	IP67
Hysteresis	Approximately 2°
Response Range	15° +/- 7°
Lead Wire Length	1 meter

#### Ordering information

<b>SR</b>	<b>20</b>	-	<b>180</b>	-	<b>90</b>
<b>Size</b>		<b>Rotation</b>		<b>Reference point</b>	
3		090	90°	45	45°
10		100	100°	90	90°
20		180	180°		
30		270	270°		



### Variable Position Sensor

#### Specifications

Type of Sensor	Solid State
Application	Relay, PLC, IC Circuit
Output Method	NPN
Load Voltage	5 to 30 VDC
Load Current	5 to 200 mA
Max. Power Consumption of Switch Control	Max. 200 mA at 24V
Max. Leak Current	Max. 10 $\mu$ A
Internal Voltage Drop	1.5 VDC
Mean Response Time	1 ms
Shock Resistance	490 m/s <sup>2</sup>
Ambient Temperature	5 to 60°C
Enclosure Rating	IP67
Hysteresis	Approximately 2°
Response Range	23° +/- 7°
Lead Wire Length	1 meter

#### Variable position sensor

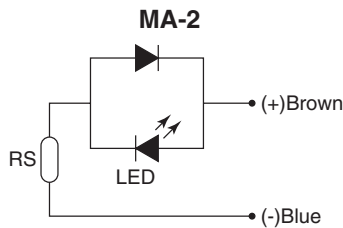
Size	Part number
1	<b>FR-1PRN</b>
3	<b>FR-3PRN</b>
10	<b>FR-10PRN</b>
20	<b>FR-20PRN</b>
30	<b>FR-30PRN</b>

PRN Sizes 50 to 800 Sensors

Ordering information

<b>FM</b>	<b>50</b>	-	<b>90</b>	-	<b>45</b>	-	<b>MA</b>	-	<b>2</b>
	<b>Size</b>		<b>Rotation</b>		<b>Reference point</b>		<b>Sensor type</b>		<b>Number sensors</b>
	50		090 90°		45 45°		MA Reed		2 Standard
	150		180 180°		90 90°		MG Solid State		
	300		270 270°						
	800								

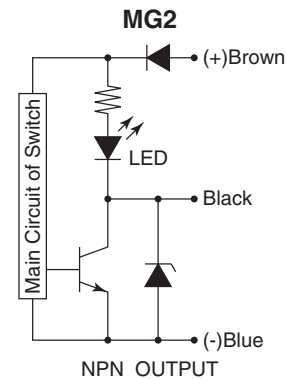
Reed sensors



Specifications

Output Method	NPN
Load Current	5 to 45 mA
Internal Voltage Drop	2V or Less
Mean Response Time	1.0 ms
Shock Resistance	294 m/s <sup>2</sup>
Ambient Temperature	5 to 60°C
Indicator Light	Red LED
Lead Wire Length	1 meter

Solid state sensors



Specifications

Application	Relay, PLC, IC Circuit
Output Method	NPN
Load Voltage	5 to 30VDC
Load Current	5 to 200 mA
Max. Power Consumption of Switch Control	Max. 20 mA at 24V
Max. Leak Current	Max. 10 µA
Internal Voltage Drop	1.5V or Less
Mean Response Time	1 ms
Shock Resistance	490 m/s <sup>2</sup>
Ambient Temperature	5 to 60°C
Enclosure Rating	IP67
Indicator Light	Red LED
Lead Wire Length	1 meter

Selection Guide

Drop-in Sensors

Solid State / Reed Sensors

Weld Immune Sensors

Cordset / Connect Block

Proximity Sensors

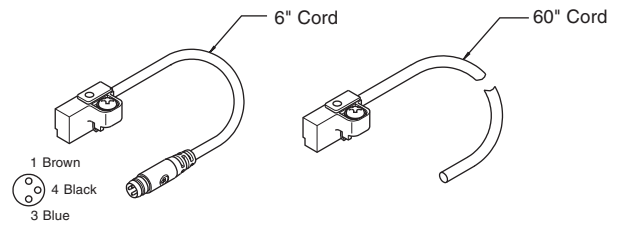
Electronic Sensors



For inventory, lead time, and kit lookup, visit [www.pdnplu.com](http://www.pdnplu.com)

**PV & XR Series Solid State (Hall Effect) Sensors**

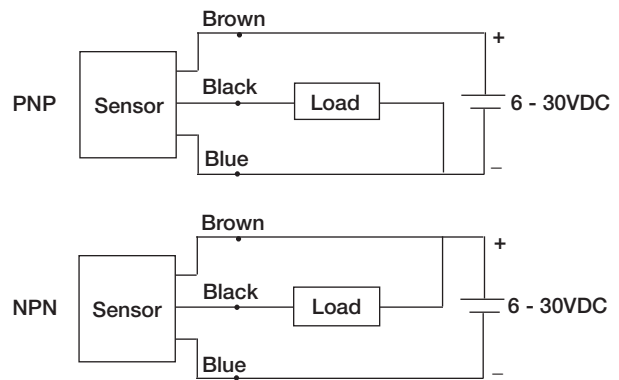
Type	LED color	Logic	Cable/Connector	Part number
N.O.	Green	PNP	1.5m black with leads	<b>SMH-1P</b>
N.O.	Red	NPN		<b>SMH-1N</b>
N.C.	Yellow	PNP		<b>SMC-1P</b>
N.C.	White/Red	NPN		<b>SMC-1N</b>
N.O.	Green	PNP	0.15m black with connector	<b>SMH-1PC</b>
N.O.	Red	NPN		<b>SMH-1NC</b>
N.C.	Yellow	PNP		<b>SMC-1PC</b>
N.C.	White/Red	NPN		<b>SMC-1NC</b>



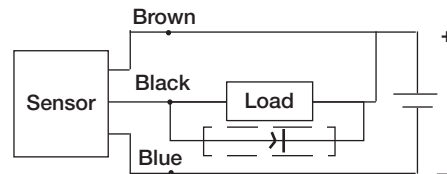
**Specifications**

Type	Solid State Type (PNP or NPN)
Switching Logic	Normally Open or Normally Closed
Supply Voltage Range	6 - 30 VDC
Max. Switch Current	150 mA
Current Consumption	7 mA at 12 VDC, 14 mA at 24 VDC
Switching Response	500 Hz Maximum
Residual Voltage	0.8 V Maximum (150 mA)
Leakage Current	10 uA Maximum
Insulation Resistance	100 M ohm min.
Min. Current for LED	1mA
Operating Temperature	-10° to 85°C (14° to 185°F)
Lead Termination	1500mm (60 in) or 150mm (6 in) with connector
Enclosure Rating	IP67
Shock Resistance	50 G's, 490 m/sec <sup>2</sup>

**Wiring connection**



**Protection circuit\***



\* When connecting an inductive load (relay, solenoid valve, etc.), a protection circuit is recommended. Use a 100V, 1A diode. (NPN connection shown.)

Selection Guide

Drop-in Sensors

Solid State / Reed Sensors

Weld Immune Sensors

Cordset / Connect Block

Proximity Sensors

Electronic Sensors



For inventory, lead times, and kit lookup, visit [www.pdnplu.com](http://www.pdnplu.com)

## PV & XR Series Reed Sensors

Reed sensors are available in a normally open or normally closed configuration. The low amp sensor is suitable for connection to PLCs or other low current devices. The high amp sensor can be used to drive sequencers, relays, coils, or other devices directly.

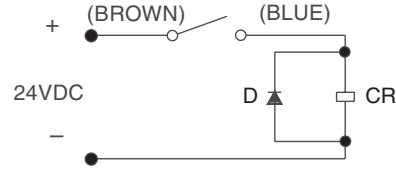
Type	LED color	Rating	Cable/Connector	Part number
N.O.	Green	High Amp	1.5m Gray with Leads	<b>SMR-1</b>
N.O.	Red	Low Amp		<b>SMR-1L</b>
N.C.	Yellow	Low Amp	0.15m Gray with Connector	<b>SMD-1L</b>
N.O.	Green	High Amp		<b>SMR-1C</b>
N.O.	Red	Low Amp	<b>SMR-1LC</b>	
N.C.	Yellow	Low Amp	<b>SMD-1LD</b>	

### SMR-1L or SMD-1L Low Amp Reed Sensor Specifications

Switching Logic	Normally Open (SMR-1L) Normally Closed (SMD-1L)
Voltage Rating	85-125 VAC or 6-30 VDC* (N.O.) 6-30 VAC, 6-30 VDC* (N.C.)
Power Rating:	
AC or DC Resistive Load	10 watts (N.O.)
AC or DC Inductive Load	5 watts (N.O.)
AC or DC	3 watts (N.C.)
Switching Current Range:	
Resistive Load (PC, Sequencer)	5-40 mA (N.O.), 5-25 mA (N.C.)
Inductive Load (Relay)	5-25 mA
Minimum Current for LED	5 mA
Switching Response	300 Hz (N.O.), 200 Hz (N.C.)
Breakdown Voltage	200 VDC
Contact Resistance	100 M ohm min.
Operating Temperature	-10° to 85°C (14° to 185°F)
Lead Termination	1.5m (6 in) or 0.15m (6 in) with connector
Enclosure Rating	IP67
Shock Resistance	30 G's, 300 m/sec <sup>2</sup>

### Integral circuit for switching contact protection

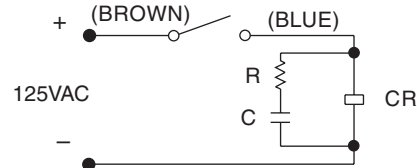
(Required for proper operation 24V DC)  
 Put Diode parallel to load (CR) with polarity as shown below.



D: Diode: select a Diode with the breakdown voltage and current rating according to the load.

CR: Relay coil (under 0.5 W coil rating)

(Recommended for longer sensor life 125V AC)  
 Put resistor and capacitor parallel to load (CR).



CR: Relay coil (under 2 W coil ratings)

R: Resistor under 1 K ohm

C: Capacitor 0.1 µF

### SMR-1 High Amp Reed Sensor Specifications

Switching Logic	Normally Open
Voltage Rating	85-125 VAC or 5-30 VDC*
Power Rating:	
AC or DC Resistive Load	10 watts
AC or DC Inductive Load	5 watts
Switching Current Range:	
Resistive Load (PC, Sequencer)	30-300 mA
Inductive Load (Relay)	30-100 mA
Minimum Current for LED	18 mA
Switching Response	300 Hz Maximum
Breakdown Voltage	200 VDC
Contact Resistance	100 M ohm min.
Operating Temperature	-10° to 85°C (14° to 185°F)
Lead Termination	1.5m (6 in) or 0.15m (6 in) with connector
Enclosure Rating	IP67
Shock Resistance	30 G's, 300 m/sec <sup>2</sup>

\* Polarity is restricted for DC operation

(+) to Brown

(-) to Blue

If these connections are reversed the contacts will close, but the LED will not light.

**Note:** Care must be taken not to exceed the Power Rating of the sensor while still observing the voltage and current limitations.

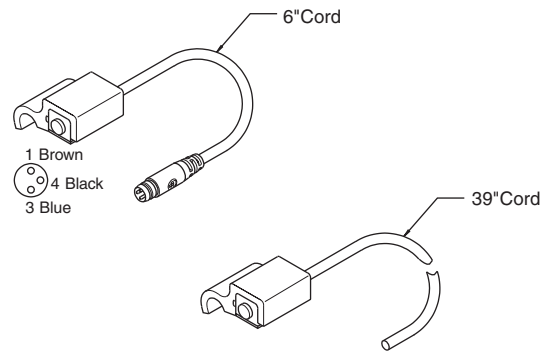


For inventory, lead time, and kit lookup, visit [www.pdnplu.com](http://www.pdnplu.com)

**PTR Series Solid State (Hall Effect) Sensors**

PTR model	PNP		NPN	
	With 6" male quick connect	With 39" potted-in leads	With 6" male quick connect	With 39" potted-in leads
10	<b>SWH-1PC</b>	<b>SWH-1P</b>	<b>SWH-1NC</b>	<b>SWH-1N</b>
15	<b>SWH-1PC</b>	<b>SWH-1P</b>	<b>SWH-1NC</b>	<b>SWH-1N</b>
20	<b>SWH-2PC</b>	<b>SWH-2P</b>	<b>SWH-2NC</b>	<b>SWH-2N</b>
25	<b>SWH-2PC</b>	<b>SWH-2P</b>	<b>SWH-2NC</b>	<b>SWH-2N</b>
32	<b>SWH-2PC</b>	<b>SWH-2P</b>	<b>SWH-2NC</b>	<b>SWH-2N</b>

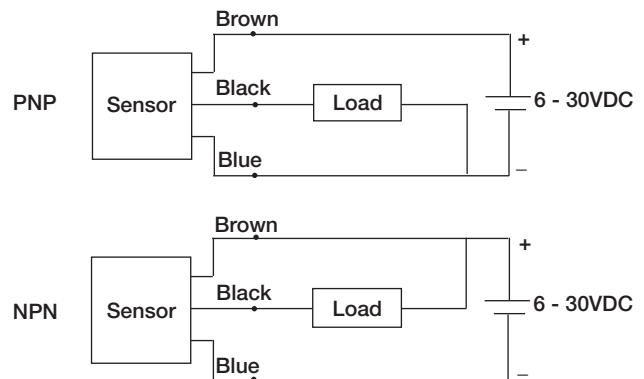
**Note:** Sensors with male quick connect option require female cordsets to be ordered separately. Please reference page K25.



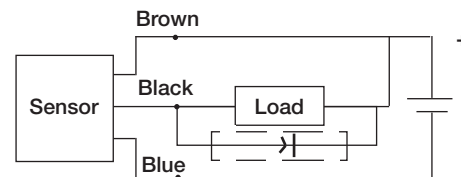
**Specifications**

Type	Solid State (PNP or NPN)
Switching Logic	Normally Open
Supply Voltage Range	6 - 30VDC
Current Output Range	Up to 100 mA at 5 VDC, Up to 200 mA at 12 VDC and 24 VDC
Current Consumption	7 mA at 5 VDC, 15 mA at 12 VDC, and 30 mA at 24 VDC
Switching Response	1000 Hz Maximum
Residual Voltage	1.5V Maximum
Leakage Current	10uA Maximum
Breakdown Voltage	1.8kVACrms for 1 sec., lead to case
Min. Current for LED	1mA
Operating Temperature	14 to 140°F (-10 to 60°C)
Enclosure Rating	Meets IEC IP67, fully encapsulated
Lead Wire	3 conductor, 24 gauge
Lead Wire Length	39 in (1 m)
Vibration Resistance	10-55 Hz, 1.5mm double amplitude

**Wiring connection**



**Protection circuit\***



\* When connecting an inductive load (relay, solenoid valve, etc.), a protection circuit is recommended. Use a 100V, 1A diode. (NPN connection shown.)

Selection Guide  
 Drop-in Sensors  
 Solid State / Reed Sensors  
 Weld Immune Sensors  
 Cordset / Connect Block  
 Proximity Sensors  
 Electronic Sensors



For inventory, lead times, and kit lookup, visit [www.pdnplu.com](http://www.pdnplu.com)

L20



## PTR Series Reed Sensors

PTR model	With 6" male quick connect	With 39" potted-in leads
10	<b>SWR-1C</b>	<b>SWR-1</b>
15	<b>SWR-1C</b>	<b>SWR-1</b>
20	<b>SWR-2C</b>	<b>SWR-2</b>
25	<b>SWR-2C</b>	<b>SWR-2</b>
32	<b>SWR-2C</b>	<b>SWR-2</b>

Sensors with male quick connect option require female cordsets to be ordered separately.

### Specifications

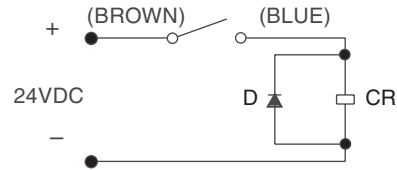
Switching Logic	Normally Open
Voltage Rating	85-125 VAC or 6-30 DC*
Power Rating	10 Watts AC or DC/Resistive Load 5 Watts AC or DC/Inductive Load
Switching Current Range	10-200 mA/Resistive Load (PC, Sequencer) 10-100 mA/Inductive Load (Relay)
Switching Response	300 Hz Maximum
Breakdown Voltage	1.8kVACrms for 1 sec., lead to case
Min. Current for LED	18mA
Operating Temperature	14 to 140°F (-10 to 60°C)
Enclosure Rating	Meets IEC IP67, fully encapsulated
Lead Wire	2 conductor, 22 Gauge
Lead Wire Length	39 in (1m)
Vibration Resistance	10-55 Hz, 1.5mm double amplitude

\* Polarity is restricted for DC operation  
 (+) to White  
 (-) to Black  
 If these connections are reversed the contacts will close, but the LED will not light.

### Protection circuit (Inductive loads)

(Required for proper operation 24VDC)

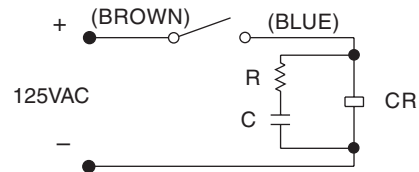
Select a diode with a breakdown voltage and current rating according to the load (CR). Place a diode in parallel to the load with the polarity as indicated:



CR: Relay coil (under 0.5W coil rating)

(Recommended for longer sensor life 125VAC)

Select a resistor and capacitor according to the load (CR). Place a resistor and capacitor in parallel to the load:



CR: Relay coil (under 2W coil rating)

R: Resistor under 1 K ohm

C: Capacitor 0.1 μF

Selection Guide

Drop-in Sensors

Solid State / Reed Sensors

Weld Immune Sensors

Cordset / Connect Block

Proximity Sensors

Electronic Sensors



For inventory, lead time, and kit lookup, visit [www.pdnplu.com](http://www.pdnplu.com)

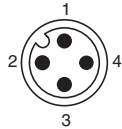


**Weld Immune Sensor**

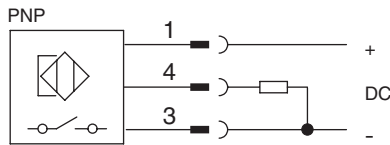


- Weld immune in all welding applications (AC, DC and medium frequency welding).
- Sensor locks the output during the welding process; when welding process stops, the sensor updates the output accordingly.

**NOTE:** Tie rod construction of the P1D Series can be ordered directly in the model code.



Pin	Function
1	Operating voltage (+VDC)
4	Output signal (N.O.)
3	-VDC
2	Not used

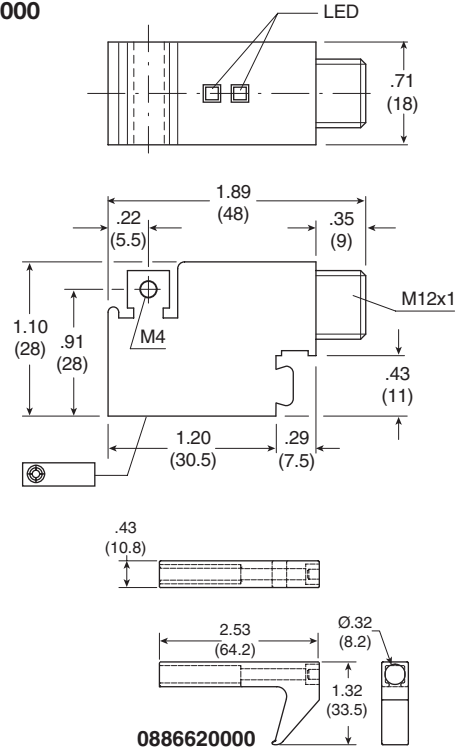


**Specifications**

Type	Electronic
Output function	Normally Open
Switching Output	PNP (3-Wire)
Operating voltage	10-30 VDC
Response sensitivity	≤ 30 Gauss
Switching frequency	40 Hz
Residual ripple	≤ 10% of Supply Voltage
Voltage drop	≤ 2 VDC
Power consumption, attenuated	≤ 32mA
Power consumption, unattenuated	≤ 18mA
Continuous current	≤ 300mA
Hysteresis	≤ 1.5mm
Repeatability	≤ 0.1mm
EMC	EN 60 947-5-2
Wire break protection	Yes
Short circuit protected	Yes
Reverse polarity protected	Yes
Power-up pulse suppression	Yes
Enclosure rating	IP67
Shock/vibration stress	30 g, 11ms, 10-55 Hz, 1mm
Operating temperature	-25°C to 75°C (-13°F to 167°F)
Housing material	Die-cast zinc with PTFE coating
LEDs	Status Indicator (yellow) Function Indicator (green)
Connector	M12 connector

Description	Part number
Weld immune sensor	<b>0886600000</b>
Tie rod bracket kit	<b>0886620000</b>

**0886600000**



Selection Guide

Drop-in Sensors

Solid State / Reed Sensors

Weld Immune Sensors

Cordset / Connect Block

Proximity Sensors

Electronic Sensors



For inventory, lead times, and kit lookup, visit [www.pdnplu.com](http://www.pdnplu.com)

## Air Piloted Switch

### Features

- Converts a magnetic field to an air pilot signal
- Band clamp allows for mounting to tie rod cylinders
- Fits 32 to 100mm bore (1.5 to 4 inch bore)
- Type 3/2 valve - NC, 2-position / spring return 3-way

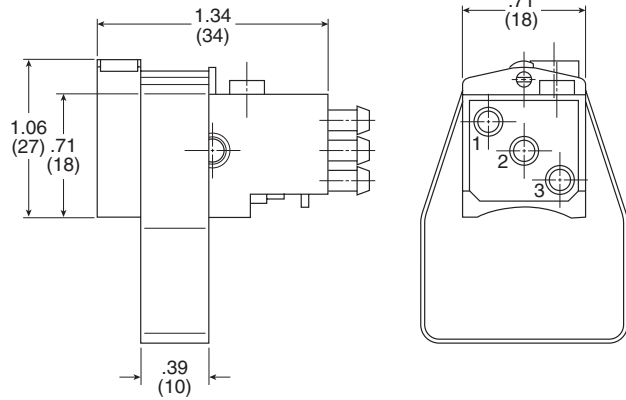
### Construction materials

Body	Macrolon, glass fiber
Mounting bracket	Aluminum, anodized
Connection	3 - 3mm OD barbs

### Characteristics

Operating temperature	14°F to 140°F (-10°C to 60°C)
Operating pressure	30 PSI to 90 PSI (2 bar to 6 bar)
Normal operating pressure	90 PSI (6 bar)
Flow	0.04 Cv (40 l/min)
Cycle rate	40 hz
Switching accuracy	± 0.008" (0.2mm) w/o air
Filtration	40 micron
Media	Filtered and regulated compressed air
Installation	In any position
Weight	Sensor 0.49 oz (0.014 kg) Sensor & bracket 0.99 oz (0.028 kg)

Description	Part number
Sensor – Air type	<b>KZ2364</b>
Mounting bracket	<b>KZ8255</b>



Selection  
Guide

Drop-in  
Sensors

Solid State /  
Reed Sensors

Weld Immune  
Sensors

Cordset /  
Connect Block

Proximity  
Sensors

Electronic  
Sensors



For inventory, lead time, and kit lookup, visit [www.pdnplu.com](http://www.pdnplu.com)

L23

**Parker Hannifin Corporation**  
 Pneumatic Division  
 Richland, Michigan  
[www.parker.com/pneumatics](http://www.parker.com/pneumatics)

**Female Quick Connect Cordset**

**8mm Cordset with Female Quick Connect**

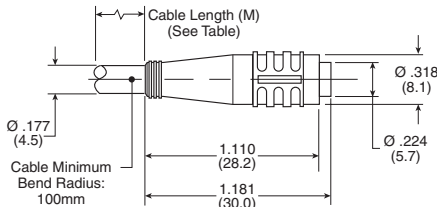
A female connector is available for all sensors with the male 8mm quick connect option. The male plug will accept a snap-on or threaded connector. Cordset part numbers are listed below:

Cable length	Threaded connector	Snap on connector
5 meters	<b>086620T005</b>	<b>086620S005</b>
2 meters	<b>086620T002</b>	<b>086620S002</b>

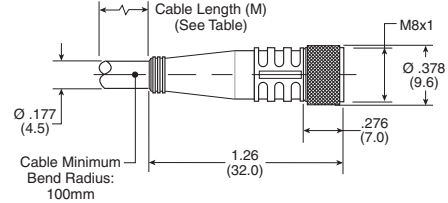
**Specifications**

Connector	Oil resistant polyurethane body material, PA 6 (Nylon) contact carrier, spacings to VDE 0110 Group C, (150 AC/DC)
Contacts	Gold plated beryllium copper, machined from solid stock
Coupling Method	Snap-Lock or chrome plated brass nut
Cord Construction	Oil resistant black PUR jacket, non-wicking, non-hygroscopic, 300V. Cable end is stripped and tinned.
Conductors	Extra high flex stranding, PVC insulation
Temperature	-40°F to 194°F (-40°C to 90°C)
Protection	NEMA 1, 3, 4, 6P and IEC IP67
Cable Length	6.56 ft (2m) or 16.4 ft (5m)

**Snap-On Straight Connector**



**Threaded Straight Connector**



**12mm Cordset with Female Quick Connect**

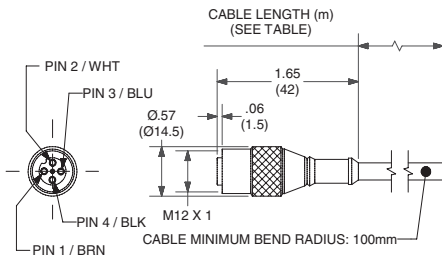
Cable length	M12 Right angle Connector	M12 Straight connector
5 meters	<b>9126487305</b>	<b>9126487205</b>
2 meters	<b>9126487302</b>	<b>9126487202</b>

A female connector is available for all sensors with the male 12mm quick connect option. The cordsets are available with a right angle or straight connector. Cordset part numbers are listed above.

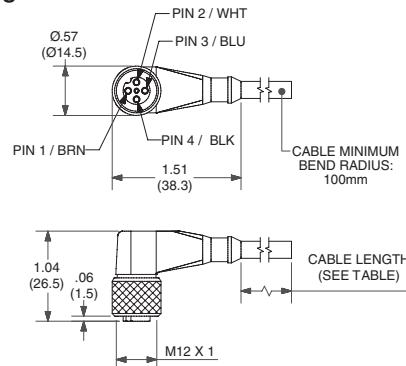
**Specifications**

Connector	Polyvinylchloride (PVC) body material, PVC contact carrier, spacing to VDE 0110 Group C, (250VAC / 300VDC)
Contacts	Gold Plated Copper Tin (CuSn), stamped from stock.
Coupling Method	Threaded nut: Chrome plated brass.
Cord Construction	PVC non-wicking, non-hygroscopic, 250VAC / 300VDC. Cable end is stripped.
Conductors	Extra high flex stranding with PVC insulation
Temperature	-13°F to 158°F (-25°C to 70°C)
Protection	NEMA 1, 3, 4, 6P and IEC IP67
Cable Length	6.56 ft (2m) or 16.4 ft (5m)

**Straight Connector**



**Right Angle Connector**



For inventory, lead times, and kit lookup, visit [www.pdnplu.com](http://www.pdnplu.com)

## Connection Block Valvetronic 110

The Valvetronic 110 is a connection block that can be used for collecting signals from sensors at various points on a machine and connecting them to the control system via a multicore cable. Valvetronic 110 can also be used for central connection of the multi-core cable to the outputs of a control system, and can be laid to a machine where the output signals can be connected. The connection block has ten 8mm snap-in connectors and a multi-core cable which is available in lengths of 3 or 10m. The connections on the block are numbered from 1 to 10. Blanking plugs are available for unused connections, as labels for marking the connections of each block.



### Connections

Ten 3-pole numbered 8 mm round snap-in female contacts



**Input block**  
 Pin 1 Common, +24 VDC  
 Pin 2 Input signal  
 Pin 3 Common, 0V



**Output block**  
 Pin 1 Common, GND Output signal  
 Pin 2 Common, 0V  
 Pin 3

### Electrical Data

Voltage	24 VDC (max. 60 V AC/75 V DC)
Insulation group	according to DIN 0110 class C
Load	max. 1 A per connection total max. 3 A

### Cable

Length	3m or 10m
Type of cable	LifYY11Y
Conductor	12
Area	0.34 mm <sup>2</sup>
Color marking	According to DIN 47 100

### Mechanical Data

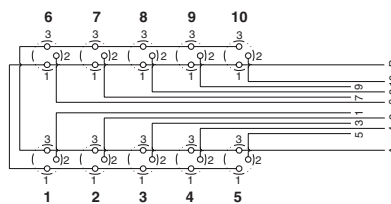
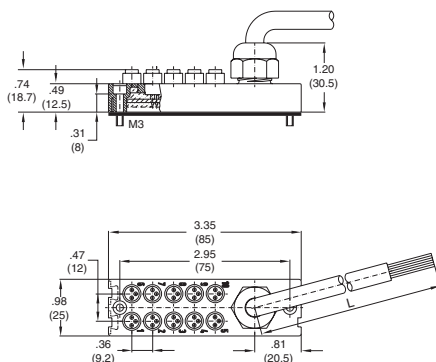
Enclosure	IP 67, DIN 40050 with fitted contacts and/or blanking plugs.
Temperature	-20 °C to 70 °C
Material	
Body	PA 6,6 VD according to UL 94
Contact holder	PBTP
Snap-in ring	LDPE
Moulding mass	Epoxy
Seal	NBR
Screws	Plated steel

**Industrial Durability**  
 Good chemical and oil resistance. Tests should be performed in aggressive environments.

### Ordering Information

Designation	Weight (kg)	Part number
Connection block Valvetronic 110 with 3m cable	0.32	<b>9121719001</b>
Connection block Valvetronic 110 with 10m cable	0.95	<b>9121719002</b>
Blanking plugs (pack of 10), use blanking plugs to close unused connections.	0.02	<b>9121719003</b>
Labels (pack of 10), White labels to insert in grooves on the side of the connection	0.02	<b>9121719004</b>

### Dimensions and Wiring Diagrams



Conductor	Color	Input	Output
1	Pink	Signal 1	Signal 1
2	Grey	Signal 2	Signal 2
3	Yellow	Signal 3	Signal 3
4	Green	Signal 4	Signal 4
5	White	Signal 5	Signal 5
6	Red	Signal 6	Signal 6
7	Black	Signal 7	Signal 7
8	Violet	Signal 8	Signal 8
9	Grey-Pink	Signal 9	Signal 9
10	Red-Blue	Signal 10	Signal 10
A	Blue	0 V	0 V
B	Brown	+24 V	PE



For inventory, lead time, and kit lookup, visit [www.pdnplu.com](http://www.pdnplu.com)

L25

**Parker Hannifin Corporation**  
 Pneumatic Division  
 Richland, Michigan  
[www.parker.com/pneumatics](http://www.parker.com/pneumatics)

**EPS-6 & 7 / CLS-1 & 4 End-of-Stroke Proximity Sensors**

**Ordering information**

Sensor type	Inductive proximity		Non-contacting magnetically actuated	
Style	EPS-7	EPS-6	CLS-1	CLS-4
Sensor part number	<b>148897****</b>	<b>148896****</b>	<b>148275****</b>	<b>149109****</b>
6' Cable	<b>0853550006</b>	<b>0859170006</b>	<b>0853550006</b>	—
12' Cable	<b>0853550012</b>	<b>0859170012</b>	<b>0853550012</b>	—
6' Cable, right angle	<b>0875470006</b>	—	<b>0875470006</b>	—

\*\*\*\* Part number suffix: \*\*\*\* 4-digit suffix indicates probe length: 0125=1.25", 0206=2.06", 0288=2.875", 0456=4.562"

**Specifications**

Style	EPS-7	EPS-6	CLS-1	CLS-4
Code designator	H	D	F	B
Sensor type	Inductive proximity	Inductive Proximity	Non-contacting magnetically actuated	Non-contacting magnetically actuated
Description	Economical, General Purpose, 2 wire device, primarily for AC applications, not suitable for 24 VDC applications.	Economical, General Purpose, 3 wire, DC sensor, dual output: sinking and sourcing	Functional replacement for AB (Mechanical) Limit Switches in many applications, or where customer needs NC contacts, zero leakage, zero voltage drop, higher or lower load current than EPS-style.	Functional replacement for AB (Mechanical) Limit Switches in many High Temperature applications, or where customer needs NC contacts, zero leakage, zero voltage drop, higher or lower load current than EPS-style.
Supply voltage	20 to 250 VAC/DC	10 to 30 VDC	24 to 240 VAC/DC	24 to 240 VAC/DC
Load current, min	8 mA	NA	NA	NA
Load current, max	300 mA	200 mA	4 AMPS @ 120 VAC 3 AMPS @ 24 VDC	4 AMPS @ 120 VAC 3 AMPS @ 24 VDC
Leakage current:	1.7 mA, max.	10 micro amps max.	—	—
Voltage drop	7 V, max.	2 VDC max.	NA	NA
Operating temperature	-14° to 158° F	-14° to 158° F	-40°F to 221° F	-40° F to 400° F
Connection	3-pin mini	5-pin mini	3-pin mini	144" PTFE coated flying leads with 1/2" conduit hub
Enclosure rating	IEC IP67	IEC IP67	NEMA 1, 2, 3, 4, 4x, 5, 6, 6P, 11, 12, 12K, 13	NEMA 1, 2, 3, 4, 4x, 5
Led indication	Yes	Yes	No	No
Short circuit protection	Yes	Yes	No	No
Weld field immunity	Yes	Yes	Yes	Yes
Output	2 wire, Normally Open with leakage current	Dual output: DC Sinking and DC Sourcing, user selectable via wiring	SPDT (Single pole double throw), Normally Open/Normally Closed, Form C	SPDT (Single pole double throw), Normally Open/Normally Closed, Form C
Approvals / marks	CE, UL, CSA	CE, UL, CSA	UL or CSA	UL or CSA
Make / break location	0.125" from end of stroke, typical. Tolerance is 0/-0.125"			
Wiring instructions	Pin 1: AC ground (Green)	Pin 1: +10 to 30 VDC (White)	Pin 1: Common (Green)	Common: (Black)
	Pin 2: Output (Black)	Pin 2: Sourcing output (Red)	Pin 2: Normally closed (Black)	Normally open: (Blue)
	Pin 3: AC line (White)	Pin 3: Grounded (not connected or required)	Pin 3: Normally open (White)	Normally closed: (Red)
		Pin 4: Sinking output (Orange)		
		Pin 5: DC common (Black)		



For inventory, lead times, and kit lookup, visit [www.pdnplu.com](http://www.pdnplu.com)

L26

**Parker Hannifin Corporation**  
Pneumatic Division  
Richland, Michigan  
[www.parker.com/pneumatics](http://www.parker.com/pneumatics)

**Series and parallel wiring**

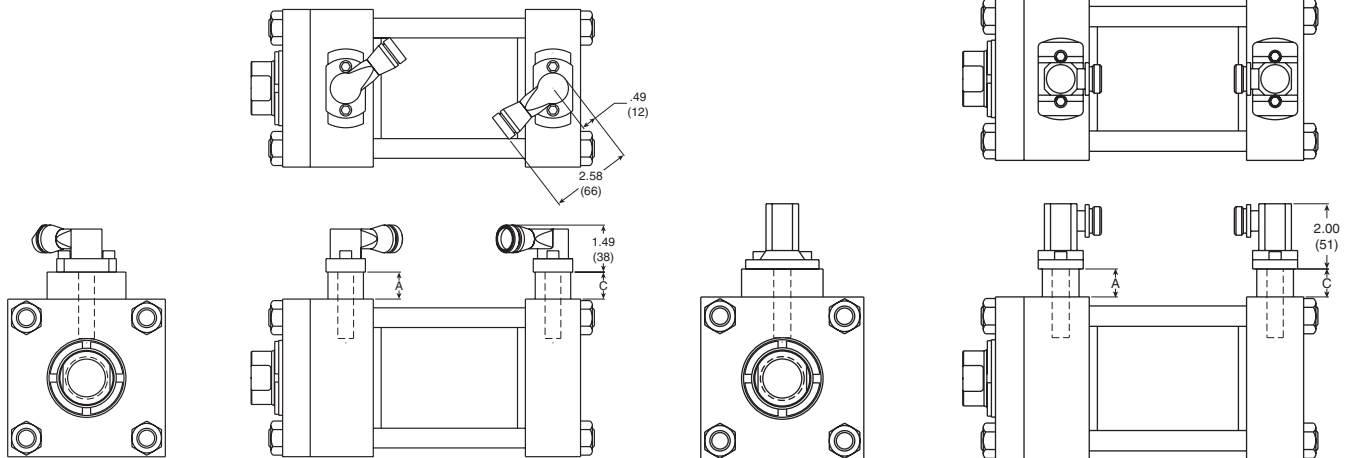
When Parker EPS-6 or 7 proximity sensors are used as inputs to programmable controllers, the preferred practice is to connect each sensor to a separate input channel of the PC. Series or parallel operations may then be accomplished by the internal PC programming.

Parker EPS-6 or 7 sensors may be hard wired for series operation, but the voltage drop through the sensors (see specifications) must not reduce the available voltage below what is needed to actuate the load.

Parker EPS-6 or 7 sensors may also be hard wired for parallel operation. However, the leakage current of each sensor will pass through the load. The total of all leakage currents must not exceed the current required to actuate the load. In most cases, the use of two or more EPS-6 or 7 sensors in parallel will require the use of a bypass (shunt) resistor.

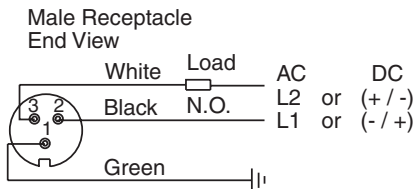
**EPS-7 & EPS-6 sensors**

**CLS-1 & 4 sensors**

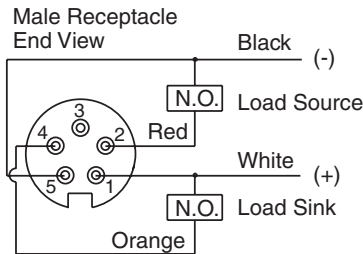


**Connector pin numbering**

**3-pin mini**



**5-pin mini**



Selection Guide

Drop-in Sensors

Solid State / Reed Sensors

Weld Immune Sensors

Cordset / Connect Block

Proximity Sensors

Electronic Sensors



For inventory, lead time, and kit lookup, visit [www.pdnplu.com](http://www.pdnplu.com)

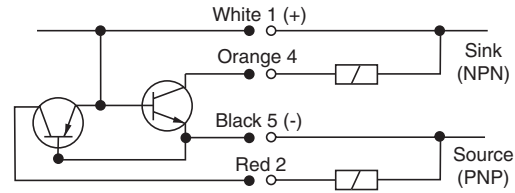
**EPS-6**

**Connectors**

The male quick disconnect on the Parker EPS-6 is a Brad Harrison 41310 connector.

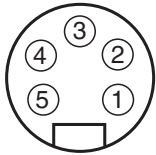
**Plug pin and cable identification**

- 1) +10 to 30 VDC (White)
- 2) Source (Red)
- 3) Grounded not connected nor required
- 4) Sink (Orange)
- 5) Common (Black)



LED Function	"Ready"	"Target"
Power Applied (No Target)	ON	OFF
Target Present	OFF	ON
Short Circuit Condition	FLASH	FLASH

Cable length	Part number
3	<b>0859170003</b>
6	<b>0859170006</b>
12	<b>0859170012</b>



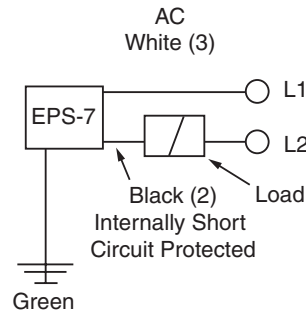
**EPS-7**

**Connectors**

The male quick disconnect on the Parker EPS-7 is a Brad Harrison 40909 connector.

Female connects must be purchased with one of the following cable lengths.

Cable length	Part number	
	Automotive	Standard
3'	<b>085356003</b>	<b>0853550003</b>
6'	<b>085356006</b>	<b>0853550006</b>
9'	<b>085356009</b>	—
12'	<b>0853560012</b>	<b>0853550012</b>



STANDARD	Pin Receptacle AC Color Code
1. Green	1
2. Black	2
3. White	3
AUTOMOTIVE	Pin Receptacle AC Color Code
1. Green	1
2. Red	2
3. Red	3



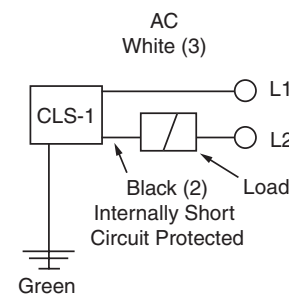
**CLS**

**Connectors**

The male quick disconnect on the Parker CLS-1 is a Brad Harrison 40909 connector.

Female connects must be purchased with one of the following cable lengths.

Cable length	Part number
3'	<b>0853550003</b>
6'	<b>0853550006</b>
9'	—
12'	<b>0853550012</b>



STANDARD	Pin Receptacle AC Color Code
1. Green	1
2. Black	2
3. White	3



The connection for the CLS-4 are 144" PTFE insulated flying leads with 1/2" conduit hub. 3-wire: Common (black), Normally open (blue), and Normally closed (red).



For inventory, lead times, and kit lookup, visit [www.pdnplu.com](http://www.pdnplu.com)



**How to specify EPS sensors**

Parker EPS proximity sensors may be ordered on 4MA and 4MAJ Series cylinders as follows:

- 1) Complete the basic cylinder model number.
- 2) Place an "S" in the model number to denote sensors and/or special features.
- 3) Mounting styles D, DB, JB, or HB should be used with caution because of possible mounting interferences.
- 4) Special modifications to cylinders other than sensors must have a written description.

- 5) Specify letter prefix "H" for EPS-7, "D" for EPS-6, "F" for CLS-1, or "B" for CLS-4, then fill in the four fields specifying port location, sensor orientation and actuation point for both head and cap. If only one sensor is used, place "XXXX" in the unused fields.

Example = H13CGG-XXXX denotes a sensor on the head end only, EPS-7

Example = BXXXX-42BGG denotes a sensor on the cap end only, CLS-4

**Head end**

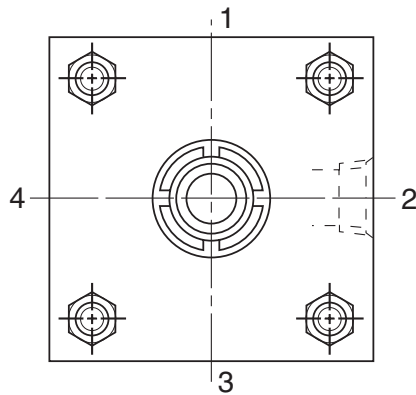
H	1	3	A	GG
Specify:	Port Location	Sensor Location	Sensor Orientation	Actuation Point
H = EPS-7	See Figure 1.	See Figure 1.	See Figure 2 for EPS-7 and EPS-6 only.	GG = End of Stroke
D = EPS-6				
F = CLS-1				
B = CLS-4				
N = Prep for sensors only				

**Cap end**

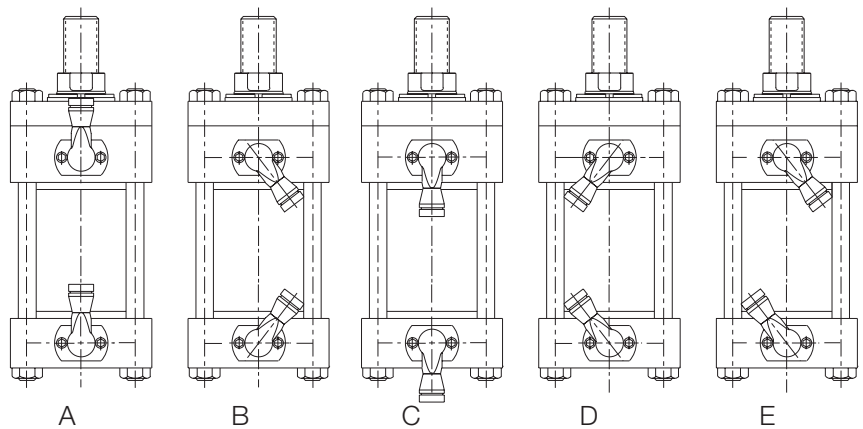
4	2	B	GG
Port Location See Figure 1.	Sensor Location See Figure 1.	Sensor Orientation See Figure 2 for EPS-7 and EPS-6 only.	Actuation Point GG = End of Stroke

**Note:** All specified sensor and port locations are as seen from rod end of cylinder.  
 \* Contact pdnapps@parker.com for this option with 4MA and 4MAJ Series cylinders.

**Figure 1**



**Figure 2**



**Example:**

4.00 CJ4MAUS14AC 12.000  
 S = H13CGG-13CGG

Selection Guide

Drop-in Sensors

Solid State / Reed Sensors

Weld Immune Sensors

Cordset / Connect Block

Proximity Sensors

Electronic Sensors



For inventory, lead time, and kit lookup, visit [www.pdnplu.com](http://www.pdnplu.com)

**PTR and HP Series Proximity Sensors**

The inductive type proximity sensor provides end of rotation indication. The non-contact probe senses the presence of the ferrous cushion spear and has no springs, plungers, cams or dynamic seals that can wear out or go out of adjustment. The sensor is solid state and meets NEMA 3, 4, & 13 specifications. For ease of wiring, the connector housing is rotatable through 360°. To rotate, lift the cover latch, position, and release.

A standard proximity sensor controls 20-230 VAC/DC loads from 5 to 500 mA. The low 1.7 mA off-state leakage current can allow use for direct PLC input. The standard short circuit protection (SCP) protects the sensor from a short in the load or line upon sensing such a condition (5 amp or greater current) by assuming a non-conductive mode. The fault condition must be corrected and the power removed to reset the sensor preventing automatic restarts.

The low voltage DC sensor is also available for use with 10-30 VDC. This sensor is in a non-rotatable housing, but does incorporate the short circuit protection.

Both sensors are equipped with two LEDs, "Ready" and "Target". The "Ready" LED is lit when power is applied and the cushion spear is not present. The "Target" LED will light and the "Ready" LED will go out when the sensor is closed, indicating the presence of the cushion spear. Both LEDs flashing indicates a short circuit condition.

**Notes:**

1. Available with or without cushions.
2. Not available with stroke adjusters.
3. Pressure rating: 3000 PSIG
4. Operating temperature: -4°F to 150°F
5. Specify sensor type, orientation and voltage when ordering.
6. The low voltage DC sensor is available in non-rotatable style only, consult representative for further information.

Selection Guide

Drop-in Sensors

Solid State / Reed Sensors

Weld Immune Sensors

Cordset / Connect Block

Proximity Sensors

Electronic Sensors

**Inductive Proximity Sensors – 8mm Barrel Type**

Proximity sensors are normally ordered with the unit as part of the model number. Use these part numbers for replacement parts only.

**Ordering information**

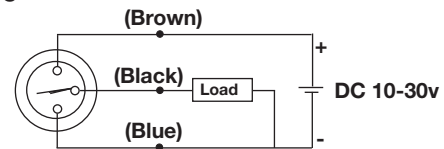
Series	PNP		NPN	
	Quick* connect	Flying leads	Quick** connect	Flying leads
HB	B8830-P	913090000	B8830-N	913090100
P5L	B8830-P	913090000	B8830-N	913090100

\* Order cordset B8757-P separately.  
\*\* Order cordset B8757-N separately.

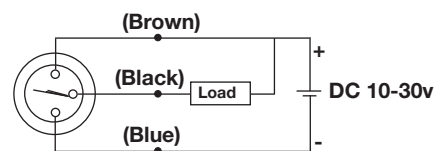
**Electrical Specifications**

Voltage	10-30 VDC (3 wire) PNP or NPN
No Load Current	5.5-9.5 mA
Continuous Current	150 mA
Switching Speed	8 ms
Switch Frequency	5000 Hz
Switching Distance	Aluminum = 0.016 in (0.4mm) Brass = 0.028 in (0.7mm) Steel = 0.039 in (1.0mm)
Overload Protection	Triggered at 170 mA
Reverse Polarity Protection	Incorporated
Temp. Range	-13 to 158°F (-25 to 70°C)
Enclosure Rating	Meets NEMA 1,3,4,6,13 and IEC IP67, fully encapsulated

**PNP wiring connection**

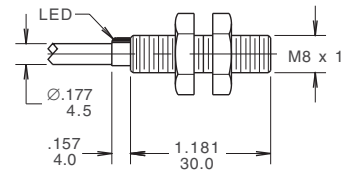


**NPN wiring connection**



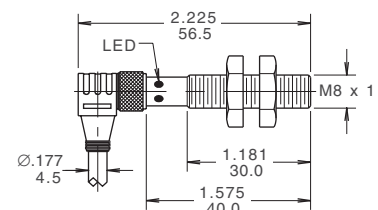
**POTTED-IN SENSOR**

Lead type sensor with 20 ft. (6m) cord length



**PLUG-IN SENSOR**

A threaded right angle cordset must be ordered separately. The cordset contains two LEDs: 1 - power, 2 - target indication. Cordset length is 20 ft. (6m).



For inventory, lead times, and kit lookup, visit [www.pdnplu.com](http://www.pdnplu.com)



## Industrial Shock Absorbers

Features	M2
General Information	M3-M7
Sizing Examples	M8-M11
Installation Examples	M12-M13
Model Rating Charts	M14-M15

### Miniature Shock Absorbers

MC 9 to MC 75 Series, Self-Compensating	M16-M17
MC 150 to MC 600 Series, Self-Compensating	M18-M19
SC 190 to SC 925 Series, Soft Contact & Self-Compensating	M20-M21
SC 300 to SC 650 Heavy Weight Series, Soft Contact & Self-Compensating	M22-M23
MA 35 to MA 900 Series, Adjustable	M24-M25

### Magnum Series Shock Absorbers

MC 33 to MC 64 Series, Self-Compensating	M26-M27
MA & ML 33 to 64, Adjustable	M28-M29
MC / MA / ML Dimensional Data	M30-M32

### Large Bore Series

1-1/2" Bore Series, Adjustable	M33-M34
2" & 3" CA Series, Heavy Industrial, Self-Compensating	M35-M38
4" CA Series, Heavy Industrial, Self-Compensating	M39-M40
2" & 3" A Series, Heavy Industrial, Adjustable	M41-M43

### Accessories

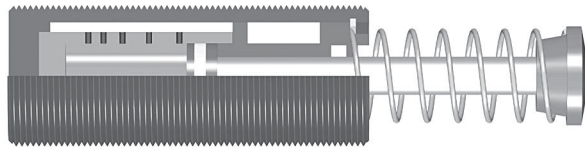
Miniature Series	M44-M47
Magnum Series	M48-M50
Air-Oil Tanks	M51

Features

Shock Absorbers

The use of one piece / closed end bodies and inner pressure chambers provides extremely strong construction, which can withstand much higher internal pressures and overload forces without mechanical damage.

The closed end / one piece bodies and inner pressure chambers, reduces the chance of sudden failure, or machine damage in the event of an overload.



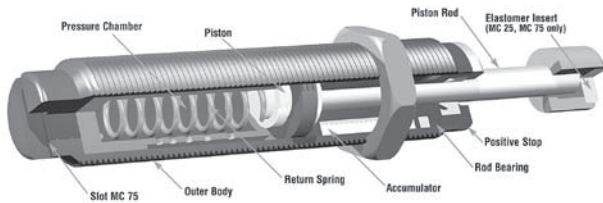
Specifications

	Oil type	Materials	Mechanical stop	Lock nut
MC 9 - MC 75	Silicone	Steel body: Black oxide finish. Piston rod: Hardened stainless steel.	Integral mechanical stop built into front of units.	Included
MC 150 - MC 600	Silicone	Steel body: Black oxide finish. Piston rod: Hardened stainless steel. Rolling seal: EPDM*	Must be provided 0.02 to 0.04 inch (0.5 to 1 mm) before end of stroke.	Included
SC 190 - SC 925	#5	Steel body: Black oxide finish. Piston rod: Hardened stainless steel.	Integral mechanical stop built into front of units.	Included
SC 300 - SC 650	#5	Steel body: Black oxide finish. Piston rod: Hardened stainless steel.	Integral mechanical stop built into front of units.	Included
MA 35 - MA 900	MA 35: #5 MA 150: Silicone MA 225, 600, 900: ATF	Steel body: Black oxide finish. Piston rod: Hardened stainless steel.	Adjustment screw for optimum deceleration.	Included
MC 33 - MC 64 Self-Compensating	ATF	Steel body: Black oxide finish. Piston rod: Hardened, high tensile steel, chrome plated.		Included
MC 33 - MC 64 Adjustable	ATF	Rod end button: Hardened steel with black oxide finish. Return spring: Zinc plated	Turn front stop collar or rear adjuster against the scale marked 0 to 9 for optimum deceleration.	Included
1-1/2" Bore Series	American 46	Steel body: Black oxide finish. Piston rod: Hardened, high tensile steel, chrome plated. Return spring: Zinc plated	Must be provided .09 inch (2.3 mm) before end of stroke.	
CA 2 - CA 4 Self-Compensating	ATF	Steel body: Black oxide finish. Piston rod: Hardened, high tensile steel, chrome plated.	Must be provided .09 inch (2.3 mm) before end of stroke.	
A 2 - A 3 Adjustable	ATF	Return spring: Zinc plated	Must be provided .09 inch (2.3 mm) before end of stroke.	

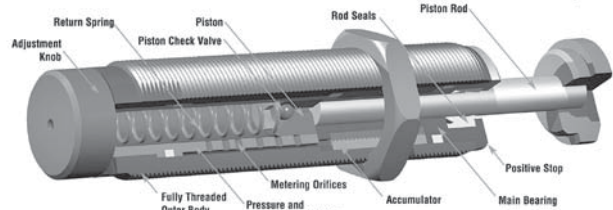
\* Seal not compatible with petroleum based fluids) If unit to be used in contact with such fluids specify neoprene rolling seal. Consider the SC2 Series as an alternative.



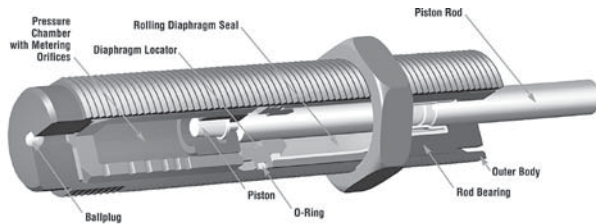
**Miniature shock absorbers**  
**MC 9 to MC 75**  
*Self-compensating*



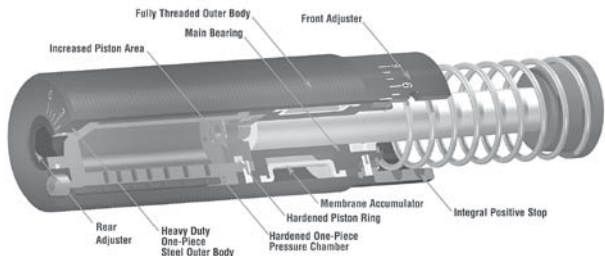
**MA series 225-900 shock absorbers**  
**(Miniature adjustable)**  
*Adjustable*



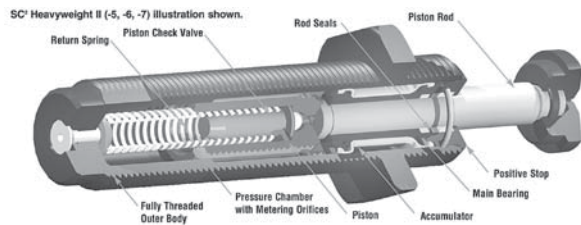
**Miniature shock absorbers**  
**MC 150, MC 225 and MC 600**  
*Self-Compensating*



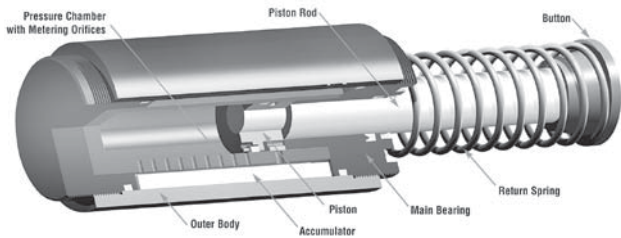
**Magnum series MA and ML 33 to 64**  
*Adjustable*



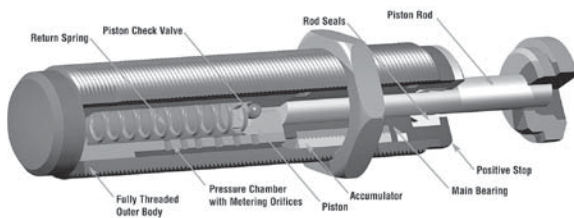
**Heavyweight shock absorbers**  
**SC 300 and SC 650**  
*Soft Contact and Self-Compensating*



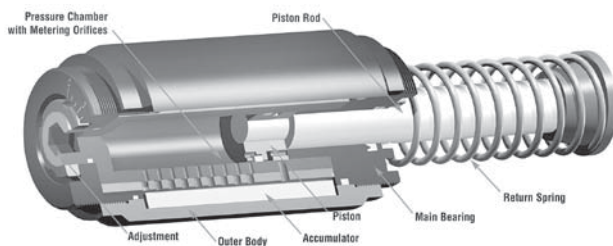
**Heavy industrial shock absorbers**  
**CA to CA 4**  
*Self-Compensating*



**Miniature shock absorbers**  
**SC 190 to SC 925**  
*Soft Contact and Self-Compensating*



**Heavy industrial shock absorbers**  
**A2 to A3**  
*Adjustable*



Industrial Shock Absorbers

M



For inventory, lead time, and kit lookup, visit [www.pdnplu.com](http://www.pdnplu.com)

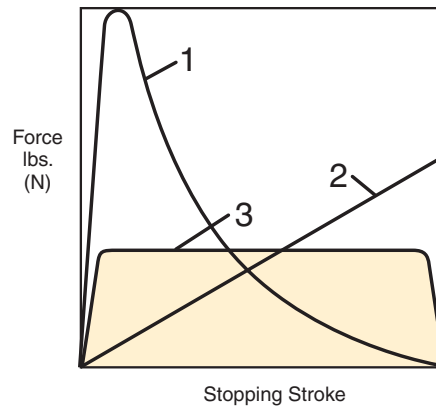
M3

**Parker Hannifin Corporation**  
 Pneumatic Division  
 Richland, Michigan  
[www.parker.com/pneumatics](http://www.parker.com/pneumatics)

**Linear Decelerators**

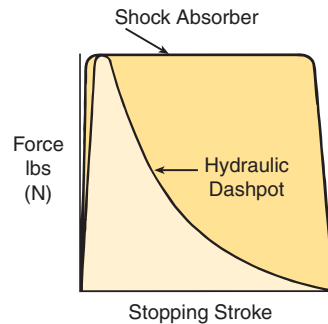
- 1. Cylinder Cushions and Dashpots (High stopping force at start of the stroke).** With only one metering orifice, the moving load is abruptly slowed down at the start of the stroke. The braking force rises to a very high peak at the start of the stroke (giving high shock loads) and then falls away rapidly.
- 2. Springs and Rubber Bumpers (High stopping forces at end of stroke).** The moving load is slowed down by a constantly rising reaction force up to the point of full compression. These devices store energy rather than dissipate it, which causes the load to bounce back.
- 3. Industrial Shock Absorbers (Uniform stopping force through the entire stroke).** The moving load is smoothly and gently brought to rest by a constant resisting force throughout the entire shock absorber stroke. The load is decelerated with the lowest possible force, in the shortest possible time, eliminating damaging force peaks and shock damage to machines and equipment. This is a linear deceleration force stroke curve and is the curve provided by industrial shock absorbers.

**Comparison**



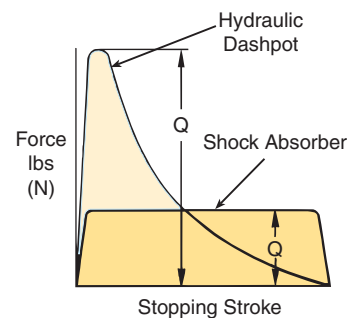
**Energy Capacity**

- Premise:** Same maximum reaction force.
- Result:** The shock absorber can absorb considerably more energy (represented by the area under the curve.)
- Benefit:** By installing a shock absorber production rates can be more than doubled without increasing deceleration forces or reaction forces on the machine.



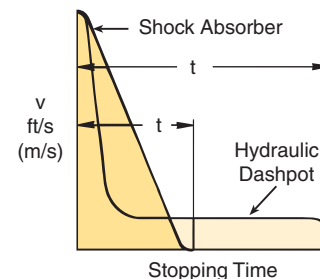
**Reaction Force (stopping force)**

- Premise:** Same energy absorption (area under the curve).
- Result:** The reaction force transmitted by the shock absorber is very much lower.
- Benefit:** By installing the shock absorber the machine wear and maintenance can be drastically reduced.



**Stopping Time**

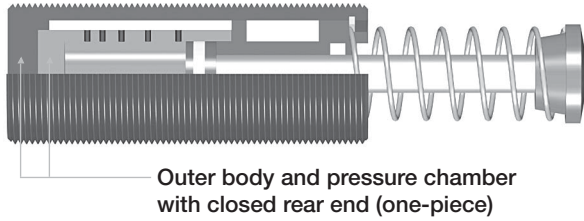
- Premise:** Same energy absorption.
- Result:** The shock absorber stops the moving load in a much shorter time.
- Benefit:** By installing a shock absorber cycle times are reduced giving much higher production rates.



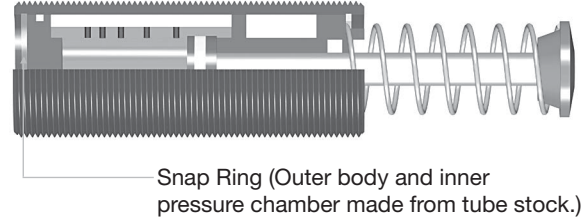
For inventory, lead times, and kit lookup, visit [www.pdnplu.com](http://www.pdnplu.com)

The use of one piece / closed end bodies and inner pressure chambers provides an extremely strong construction, which can withstand much higher internal pressures and overload forces without mechanical damage. Consider what happens if the shock absorber is accidentally overloaded or in the unlikely event of partial oil loss due to excessive seal wear or damage. Compare the internal design used by Parker with that of some of its competitors:

**Parker Shock Absorber**



**Other Shock Absorber**



Parker builds its shock absorbers with closed end/one piece bodies and inner pressure chambers, which greatly reduces the chance of sudden failure, or machine damage in the event of an overload.

Some other manufacturers use bodies and inner pressure chambers made from tube stock. The internal parts are held in by a snap ring etc. which then takes all the load and can fail suddenly and catastrophically.

**What happens with an overload or gradual oil loss?**

Harder bottoming out force becomes apparent. The shock absorber continues to work and can be replaced then or at the end of the shift.

**What happens with an overload or gradual oil loss?**

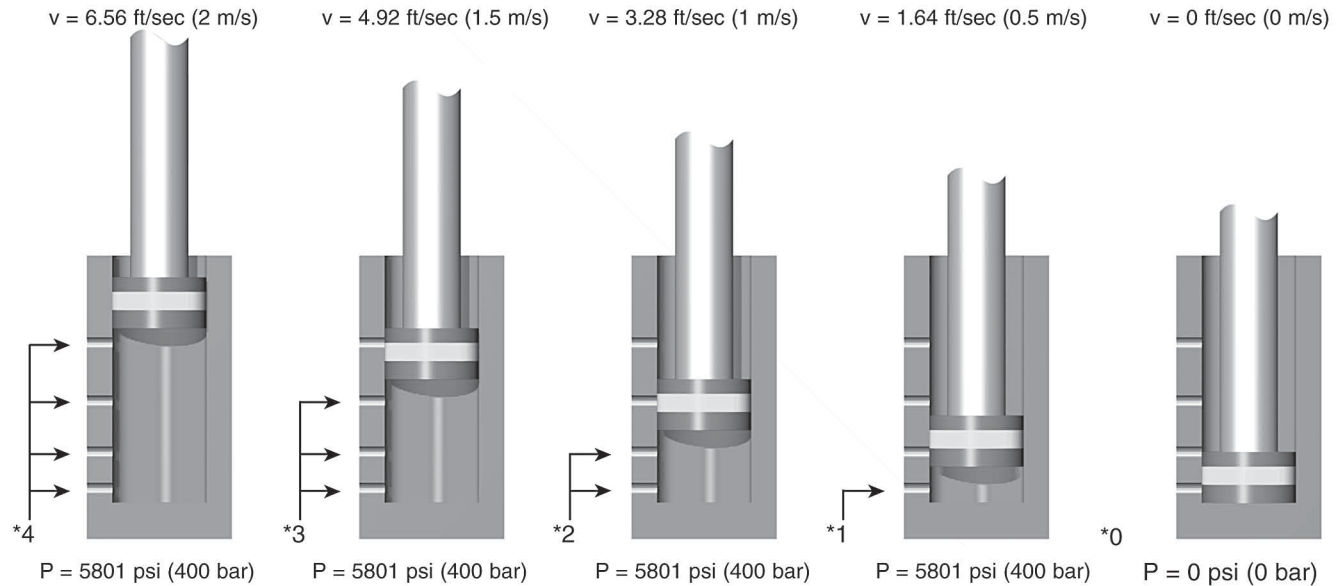
The snap ring breaks or is extruded due to excessive force. Machine damage!! Equipment Stops!! Production Halted!! Emergency Repair!!

**Corrective Action:**

Remove and replace the shock absorber. Refill with fresh oil or repair.

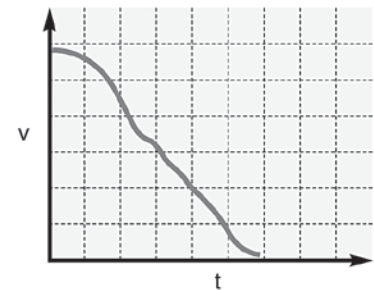
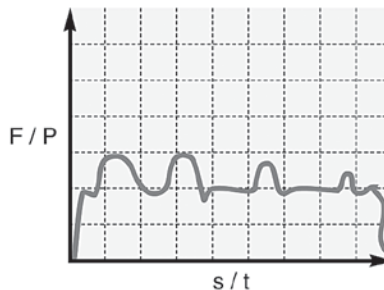
**Corrective Action:**

Remove and replace the shock absorber with new one (repair not possible).



\* As a moving load impacts the shock absorber, the piston travels through stroke and forces hydraulic fluid through the multi-orifice inner tube. The total orifice area decreases at a rate consistent with the decay of impact velocity, resulting in true linear deceleration.

- F = Force lbs (N)
- P = Internal pressure psi (bar)
- s = Stroke in (m)
- t = Deceleration time (s)
- v = Velocity ft/s (m/s)



For inventory, lead time, and kit lookup, visit [www.pdnplu.com](http://www.pdnplu.com)

M5

**Parker Hannifin Corporation**  
 Pneumatic Division  
 Richland, Michigan  
[www.parker.com/pneumatics](http://www.parker.com/pneumatics)

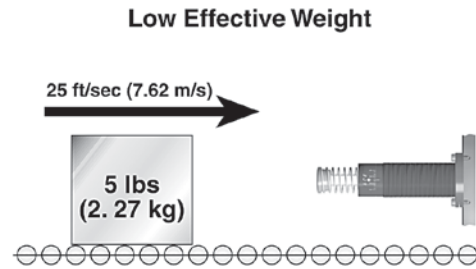
Effective weight is an important factor in selecting shock absorbers. A shock absorber “sees” the impact of an object in terms of weight and velocity only; it does not “see” any propelling force. The effective weight can be thought of as the weight that the shock absorber “sees” on impact. Effective weight includes the effect of the propelling force on the performance of the shock absorber.

Failing to consider the effective weight may result in improper selection and poor performance of the shock absorber. Under extreme conditions, an effective weight that is too low may result in high forces at the start of stroke (high on-set force). However, an effective weight that is too high for the shock absorber may cause high forces at the end of stroke (high set-down force).

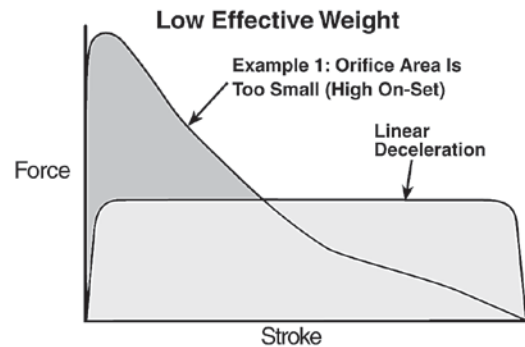
**Consider the following examples:**

1. A 5 lb (2.27 kg) weight travelling at 25 ft/sec (7.62 m/s) has 625 lbs (71 Nm) of kinetic energy (**Figure A**). On this basis alone, an MA 3325 would be selected. However, because there is no propelling force, the calculated effective weight is five pounds – which is below the effective weight range of the standard MA 3325. This is a high on-set force at the start of the stroke (**Figure B**). The solution is to use a specially-orificed shock absorber to handle the load.
2. A weight of 50 lbs (22.68 kg) has an impact velocity of 0.5 ft/sec (0.15 m/s) with a propelling force of 800 lbs (111N) (**Figure C**). The total impact energy is 802.5 inch-pounds. Again, an MA 3325 would be selected based just on the energy. The effective weight is calculated to be 16,050 pounds (7,280 kg). This is well above the range of the standard MA 3325. If this shock absorber is used, high-set-down forces will result (**Figure D**). In this case, the solution is to use a ML 3325, which is designed to work in low-velocity, high-effective weight applications.

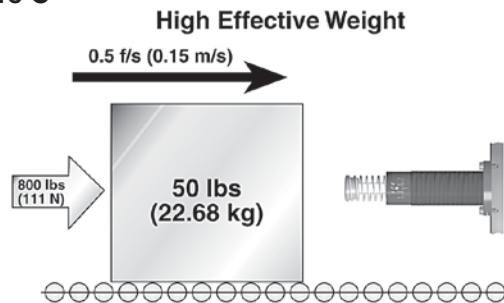
**Figure A**



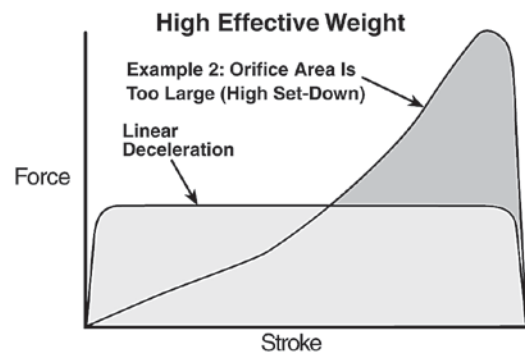
**Figure B**



**Figure C**



**Figure D**



**Computer-Aided Simulation**

By combining application data with a shock absorbers design parameters, Parker engineers can create a picture of how the shock will perform when impacted by the application load. Peak reaction force, peak deceleration (G's), time through stroke, and velocity decay are identified with extreme accuracy. The user benefits by having the guesswork taken out of sizing decisions and by knowing before installation how his shock problem will be solved.



**Self-Compensating Shock Absorbers**

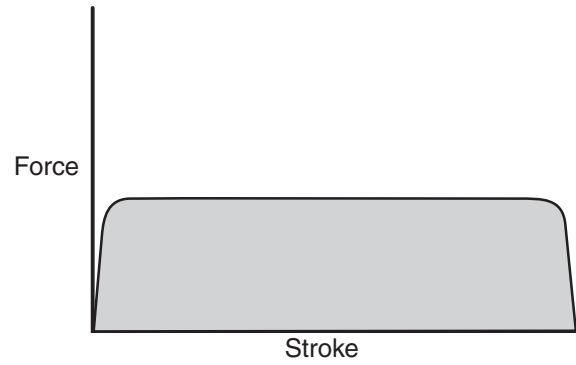
In cases where non-adjustability is beneficial but the features of an adjustable shock absorber are required, self-compensating shocks meet both needs. With a range of effective weight, a self-compensating shock absorber will provide acceptable deceleration under changing energy conditions.

The orifice profile, designed by a computer that constantly arranges the size and location of each orifice while inputting changing effective weights, neutralizes the effect of changing fluid coefficients, weight, velocity, temperature and fluid compressibility.

**Figure A**

A linear decelerator by definition decelerates a moving weight at a linear or constant rate of deceleration. The adjustable shock absorber is able to provide linear deceleration when operated within its energy capacity and effective weight range by dialing in the required orifice area. The resulting force-stroke curve (Figure A) shows optimum (lowest) stopping force.

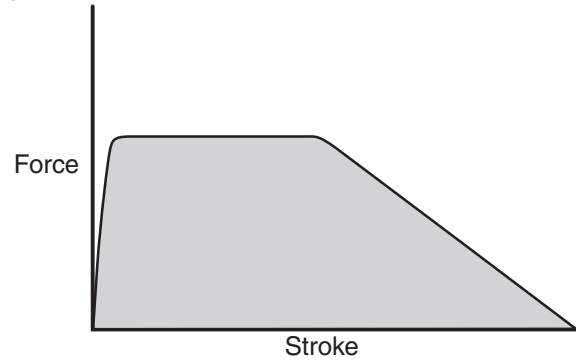
**Figure A**



**Figure B**

Figure B shows the force-stroke of a self-compensating shock absorber stopping a weight at the low end of its effective weight range. Note how the reaction forces are no longer constant but are still acceptable. The curve is skewed slightly higher at the beginning of the stroke and dips lower at the end.

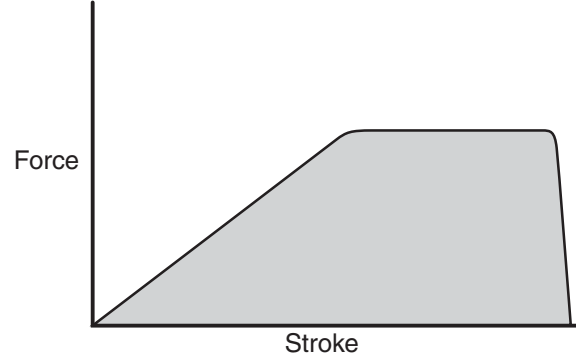
**Figure B**



**Figure C**

Figure C is a force-stroke curve of the same self-compensating shock absorber in Figure B but at the high end of its effective weight range. The energy curve is now skewed upward at the end of stroke and still yields acceptable deceleration.

**Figure C**

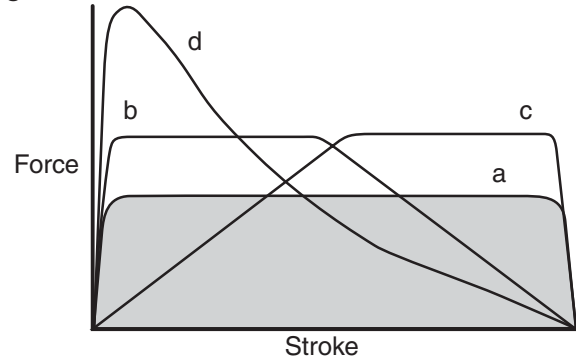


**Figure D**

Figure D is a family of force-stroke curves:

- a. Adjustable shock absorber properly tuned, or hydro shock perfectly matched.
- b. Self-compensating shock absorber at the low end of its effective weight range.
- c. Self-compensating shock absorber at the high end of its effective weight range.
- d. Adjustable closed down, or hydro shock not matched (dashpot effect).

**Figure D**



Industrial Shock Absorbers

M

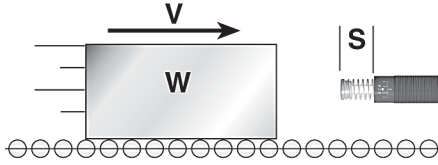


For inventory, lead time, and kit lookup, visit [www.pdnplu.com](http://www.pdnplu.com)

W = Moving Weight (lbs)      Hp = Motor Power (horsepower)      E<sub>1</sub> = Kinetic Energy (in lbs)  
 V = Impact Velocity (ft/sec)      Mu = Coefficient of Friction      E<sub>2</sub> = Propelling Force Energy (in lbs)  
 Fp = Known Propelling Force (lbs)      C = Cycles per Hour (/hour)      E<sub>3</sub> = Energy per Cycle (in lbs)  
 B = Propelling Cylinder Bore (inches)      s = Stroke Length of Shock Absorber (inches)      E<sub>4</sub> = Energy per hour (in lbs/hour)  
 R = Propelling Cylinder Rod (inches)      F = Propelling Force at Shock Absorber (lbs)      We = Effective Weight (lbs)  
 P = Air Pressure (psi)

**H1 Weight with No Propelling Force**

**Examples: Crash Testers, Emergency Stops**



**FORMULA**

E<sub>1</sub> = (0.186)•(W)•(V<sup>2</sup>)  
 E<sub>2</sub> = (F)•(s)  
 E<sub>3</sub> = E<sub>1</sub> + E<sub>2</sub>  
 E<sub>4</sub> = (E<sub>3</sub>)•(C)  
 We = E<sub>3</sub> / (0.186)•(V<sup>2</sup>)

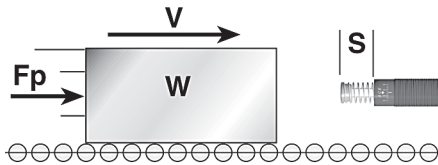
**EXAMPLE**

W = 500 lbs      E<sub>1</sub> = (0.186)•(500)•(3<sup>2</sup>) = 837 in lbs  
 V = 3 ft/sec      E<sub>2</sub> = (0)•(1) = 0 in lbs  
 Fp = 0      E<sub>3</sub> = 900 + 0 = 837 in lbs  
 C = 500/hour      E<sub>4</sub> = (837)•(500) = 418,500 in lbs/h  
 We = 837 / (0.186)•(3<sup>2</sup>) = 500 lbs

*H1 - Select from Model Rating Chart: MC 3325-3 or MA 3325*

**H2 Weight with Propelling Force**

**Transfer Devices, Safety Doors, Cutting Shears**



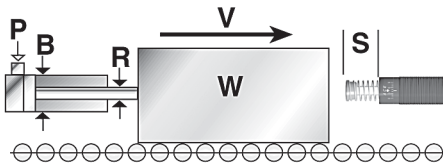
F = Fp  
 E<sub>1</sub> = (0.186)•(W)•(V<sup>2</sup>)  
 E<sub>2</sub> = (F)•(s)  
 E<sub>3</sub> = E<sub>1</sub> + E<sub>2</sub>  
 E<sub>4</sub> = (E<sub>3</sub>)•(C)  
 We = E<sub>3</sub> / (0.186)•(V<sup>2</sup>)

W = 14 lbs      F = 30 = 30 lbs  
 V = 2.2 ft/sec      E<sub>1</sub> = (0.186)•(14)•(2.2<sup>2</sup>) = 12.6 in lbs  
 Fp = 30 lbs      E<sub>2</sub> = (30)•(0.4) = 12 in lbs  
 C = 100/hour      E<sub>3</sub> = 12.6 + 12 = 24.6 in lbs  
 s = 0.4 inches      E<sub>4</sub> = (24.6)•(100) = 2,460 in lbs/h  
 We = 24.6 / (0.186)•(2.2<sup>2</sup>) = 27.3 lbs

*H2 - Select from Model Rating Chart: MC 75-3*

**H3 Weight with Propelling Cylinder**

**Pick-and Place Units, Linear Slides, Robotics**



F = 0.785•(B<sup>2</sup>-R<sup>2</sup>)•(P)  
 E<sub>1</sub> = (0.186)•(W)•(V<sup>2</sup>)  
 E<sub>2</sub> = (F)•(s)  
 E<sub>3</sub> = E<sub>1</sub> + E<sub>2</sub>  
 E<sub>4</sub> = (E<sub>3</sub>)•(C)  
 We = E<sub>3</sub> / (0.186)•(V<sup>2</sup>)

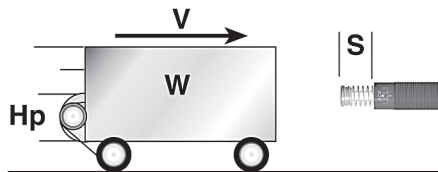
W = 120 lbs      F = 0.785•(1.5<sup>2</sup>-0<sup>2</sup>)•60 = 106 lbs  
 V = 2 ft/sec      E<sub>1</sub> = (0.186)•(120)•(2<sup>2</sup>) = 89.3 in lbs  
 B = 1.5 inches      E<sub>2</sub> = (106)•(0.75) = 79.5 in lbs  
 R = 0 inches      E<sub>3</sub> = 89.3 + 79.5 = 168.8 in lbs  
 P = 60 psi      E<sub>4</sub> = (168.8)•(60) = 10,128 in lbs/h  
 C = 60/hour      We = 168.8 / (0.186)•(2<sup>2</sup>) = 226.9 lbs  
 s = 0.75 inches

Note: R = 0 when using a rodless cylinder or a cylinder working in extension.

*H3 - Select from Model Rating Chart: MA 225 or SC 300-4*

**H4 Weight with Motor Drive**

**Lift Trucks, Stacker Units, Overhead Cranes**



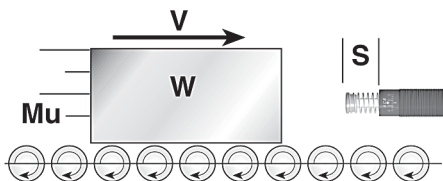
F = (550)•(ST)•(Hp) / V  
 E<sub>1</sub> = (0.186)•(W)•(V<sup>2</sup>)  
 E<sub>2</sub> = (F)•(s)  
 E<sub>3</sub> = E<sub>1</sub> + E<sub>2</sub>  
 E<sub>4</sub> = (E<sub>3</sub>)•(C)  
 We = E<sub>3</sub> / (0.186)•(V<sup>2</sup>)

W = 2,100 lbs      F = (550)•(2.5)•(2) / 1 = 2,750 lbs  
 V = 1 ft/sec      E<sub>1</sub> = (0.186)•(2,100)•(1<sup>2</sup>) = 390.6 in lbs  
 Hp = 2 hp      E<sub>2</sub> = (2,750)•(2) = 5,500 in lbs  
 ST = 2.5      E<sub>3</sub> = 390.6 + 5,500 = 5,890.6 in lbs  
 C = 20/hour      E<sub>4</sub> = (5,890.6)•(20) = 117,812 in lbs/h  
 s = 2 inches      We = 5,890.6 / (0.186)•(1<sup>2</sup>) = 31,670 lbs

*H4 - Select from Model Rating Chart: ML 6450 or MC 6450-4*

**H5 Weight on Power Rollers/Conveyor**

**Pallet Line, Friction Conveyor Belt, Steel Tube Transfer**



F = (W)•(Mu)  
 E<sub>1</sub> = (0.186)•(W)•(V<sup>2</sup>)  
 E<sub>2</sub> = (F)•(s)  
 E<sub>3</sub> = E<sub>1</sub> + E<sub>2</sub>  
 E<sub>4</sub> = (E<sub>3</sub>)•(C)  
 We = E<sub>3</sub> / (0.186)•(V<sup>2</sup>)

W = 250 lbs      F = (250)•(0.2) = 50 lbs  
 V = 2.5 ft/sec      E<sub>1</sub> = (0.186)•(250)•(2.5<sup>2</sup>) = 290.6 in lbs  
 Mu = 0.2      E<sub>2</sub> = (50)•(1) = 50 in lbs  
 C = 180/hour      E<sub>3</sub> = 290.6 + 50 = 340.6 in lbs  
 s = 1 inch      E<sub>4</sub> = (340.6)•(180) = 61,308 in lbs/h  
 We = 340.6 / (0.186)•(2.5<sup>2</sup>) = 293 lbs

*H5- Select from Model Rating Chart: MA 600 or SC 650-3*

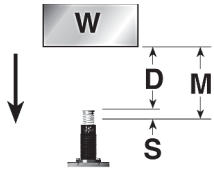
W = Moving Weight  
V = Impact Velocity  
Fp = Known Propelling Force  
M = Total Distance Moved by Weight  
D = Distance Moved by Weight to Shock

(lbs) A = Angle of Inclined Plane  
(ft/sec) W<sub>cw</sub> = Counter Weight  
(lbs) C = Cycles per Hour  
(inches) s = Stroke Length of Shock Absorber  
(inches) F = Propelling Force at Shock Absorber

(°) E<sub>1</sub> = Kinetic Energy (in lbs)  
(lbs) E<sub>2</sub> = Propelling Force Energy (in lbs)  
(/hour) E<sub>3</sub> = Energy per Cycle (in lbs)  
(inches) E<sub>4</sub> = Energy per hour (in lbs/hour)  
(lbs) We = Effective Weight (lbs)

**V1 Weight, Vertical Free Fall**

**Examples: Elevator Emergency Stops, Flying Shears, Test Equipment**



**FORMULA**  
 $D = (M) - (s)$   
 $V = \sqrt{(5.4) \cdot (D) \cdot \sin(A)}$   
 $F = (W) \cdot \sin(A)$   
 $E_1 = (0.186) \cdot (W) \cdot (V^2)$   
 $E_2 = (F) \cdot (s)$   
 $E_3 = E_1 + E_2$   
 $E_4 = (E_3) \cdot (C)$   
 $We = E_3 / (0.186) \cdot (V^2)$

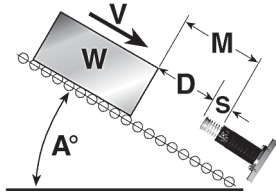
**EXAMPLE**  
 W = 200 lbs  
 M = 18 inches  
 C = 60/hour  
 s = 3 inches

D = (18) - (3) = 15 inches  
 V =  $\sqrt{(5.4) \cdot (15)}$  = 9 ft/sec  
 F = 200 = 200 lbs  
 E<sub>1</sub> = (0.186) • (200) • (9<sup>2</sup>) = 3,013.2 in lbs  
 E<sub>2</sub> = (200) • (3) = 600 in lbs  
 E<sub>3</sub> = 3,013.2 + 600 = 3,613.2 in lbs  
 E<sub>4</sub> = (3,013.2) • (60) = 216,792 in lbs/hour  
 We = 3,013.2 / (0.186) • (9<sup>2</sup>) = 239.8 lbs

V1 - Select from Model Rating Chart: MA 4575

**V2 Weight Sliding Down Incline**

**Inclined Non-Powered Conveyor, Package Chute, Parts Transfer Ramp**



**FORMULA**  
 $D = (M) - (s)$   
 $V = \sqrt{(5.4) \cdot (D) \cdot \sin(A)}$   
 $F = (W) \cdot \sin(A)$   
 $E_1 = (0.186) \cdot (W) \cdot (V^2)$   
 $E_2 = (F) \cdot (s)$   
 $E_3 = E_1 + E_2$   
 $E_4 = (E_3) \cdot (C)$   
 $We = E_3 / (0.186) \cdot (V^2)$

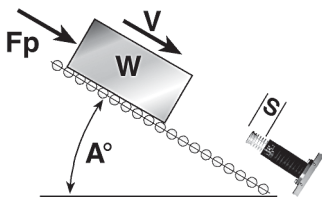
W = 1,000 lbs  
 M = 15 inches  
 A = 30°  
 C = 190/hour  
 s = 2 inches

D = (15) - (2) = 13 inches  
 V =  $\sqrt{(5.4) \cdot (13) \cdot \sin(30)}$  = 5.9 ft/sec  
 F = 500 = 500 lbs  
 E<sub>1</sub> = (0.186) • (1,000) • (5.9<sup>2</sup>) = 6,474.7 in lbs  
 E<sub>2</sub> = (500) • (2) = 1,000 in lbs  
 E<sub>3</sub> = 6,474.7 + 1,000 = 7,474.7 in lbs  
 E<sub>4</sub> = (7,474.7) • (190) = 1,420,193 in lbs/hour  
 We = 7,474.7 / (0.186) • (5.9<sup>2</sup>) = 1,154.5 lbs

V2 - Select from Model Rating Chart: MCA 6450-1 or -2

**V3 Down Incline with Propelling Force**

**Inclined Conveyor Belt, High Speed Safety Doors**



**FORMULA**  
 $F = (W) \cdot \sin(A) + (Fp)$   
 $E_1 = (0.186) \cdot (W) \cdot (V^2)$   
 $E_2 = (F) \cdot (s)$   
 $E_3 = E_1 + E_2$   
 $E_4 = (E_3) \cdot (C)$   
 $We = E_3 / (0.186) \cdot (V^2)$

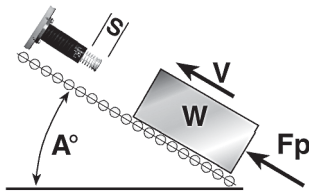
W = 100 lbs  
 V = 2 ft/sec  
 Fp = 50 lbs  
 A = 15°  
 C = 30/hour  
 s = 0.5 inches

F = (100) • sin(15) + (50) = 75.9  
 E<sub>1</sub> = (0.186) • (100) • (2<sup>2</sup>) = 74.4 in lbs  
 E<sub>2</sub> = (75.9) • (0.5) = 38 in lbs  
 E<sub>3</sub> = 74.4 + 38 = 112.4 in lbs  
 E<sub>4</sub> = (112.4) • (30) = 3,370.5 in lbs  
 We = 112.4 / (0.186) • (2<sup>2</sup>) = 151.1 in lbs

V3 - Select from Model Rating Chart: MC 150H

**V4 Up Incline with Propelling Force**

**Elevator, Inclined Power Conveyor**



**FORMULA**  
 $F = (Fp) - (W) \cdot \sin(A)$   
 $E_1 = (0.186) \cdot (W) \cdot (V^2)$   
 $E_2 = (F) \cdot (s)$   
 $E_3 = E_1 + E_2$   
 $E_4 = (E_3) \cdot (C)$   
 $We = E_3 / (0.186) \cdot (V^2)$

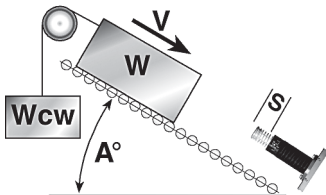
W = 450 lbs  
 V = 1 ft/sec  
 Fp = 600 lbs  
 A = 90°  
 C = 60/hour  
 s = 1 inch

F = (600) - (450) • sin(90) = 150 lbs  
 E<sub>1</sub> = (0.186) • (450) • (1<sup>2</sup>) = 83.7 in lbs  
 E<sub>2</sub> = (150) • (1) = 150 in lbs  
 E<sub>3</sub> = 90 + 150 = 234 in lbs  
 E<sub>4</sub> = (234) • (60) = 14,022 in lbs/hour  
 We = 240 / (0.2) • (1<sup>2</sup>) = 1,258.1 lbs

V4 - Select from Model Rating Chart: MA 600 or SC 650-4

**V5 Down Incline with Counter Weight**

**Lifting Door with Counter Balance**



**FORMULA**  
 $F = (W) \cdot \sin(A) - W_{cw}$   
 $E_1 = (0.186) \cdot (W) \cdot (V^2)$   
 $E_2 = (F) \cdot (s)$   
 $E_3 = E_1 + E_2$   
 $E_4 = (E_3) \cdot (C)$   
 $We = E_3 / (0.186) \cdot (V^2)$

W = 1,500 lbs  
 V = 0.5 ft/sec  
 A = 45°  
 W<sub>cw</sub> = 500 lbs  
 C = 1/hour  
 s = 1 inch

F = (1,500) • sin(45) - 500 = 560.7 lbs  
 E<sub>1</sub> = (0.186) • (1,500) • (0.5<sup>2</sup>) = 69.8 in lbs  
 E<sub>2</sub> = (560.7) • (1) = 560.7 in lbs  
 E<sub>3</sub> = 69.8 + 560.7 = 630.5 in lbs  
 E<sub>4</sub> = (636) • (1) = 630.5 in lbs/hour  
 We = 630.5 / (0.186) • (0.5<sup>2</sup>) = 13,559.1 lbs

V5 - Select from Model Rating Chart: ML 3325

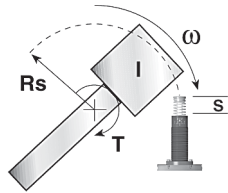


For inventory, lead time, and kit lookup, visit [www.pdnplu.com](http://www.pdnplu.com)

Rotary Sizing Examples

W = Moving Weight (lbs)	T = Propelling Torque (lbs-in)	C = Cycles per Hour (/hour)
V = Impact Velocity (ft/sec)	Rs = Mounting Radius of the Shock (inches)	E <sub>1</sub> = Kinetic Energy (in lbs)
Wa = Apparent Weight at Shock Absorber (lbs)	Rt = Radius to Edge of Turntable (inches)	E <sub>2</sub> = Propelling Force Energy (in lbs)
ω = Angular Velocity (°/sec)	s = Stroke Length of Shock Absorber (inches)	E <sub>3</sub> = Energy per Cycle (in lbs)
I = Moment of Inertia (lb-ft-sec <sup>2</sup> )	H = Thickness of Object (inches)	E <sub>4</sub> = Energy per hour (in lbs/hour)
k = Radius of Gyration (inches)	L = Length of Object (inches)	We = Effective Weight (lbs)

**R1 Moment of Inertia, Horizontal Plane**      **Examples: Swing Bridges, Radar Antenna**



**FORMULA**

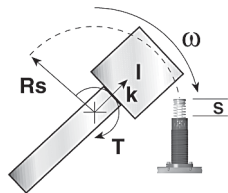
$$\begin{aligned} Wa &= (4637 \cdot I) / Rs^2 \\ V &= (Rs) \cdot (\omega) / 688 \\ F &= T / Rs \\ E_1 &= (0.186) \cdot (Wa) \cdot (V^2) \\ E_2 &= (F) \cdot (s) \\ E_3 &= E_1 + E_2 \\ E_4 &= (E_3) \cdot (C) \\ We &= E_3 / (0.186) \cdot (V^2) \end{aligned}$$

**EXAMPLE**

I = 3,930 lb-ft-sec <sup>2</sup>	Wa = (4,637 • 3,930) / (40 <sup>2</sup> )	= 11,390 lbs
ω = 172°/sec	V = (40) • (172) / 688	= 10 ft/sec
T = 480,000 lbs-in	F = 480,000 / 40	= 12,000 lbs
Rs = 40 inches	E <sub>1</sub> = (0.186) • (11,390) • (10 <sup>2</sup> )	= 211,854 in lbs
C = 30/hour	E <sub>2</sub> = (12,000) • (6)	= 72,000 in lbs
s = 6 inches	E <sub>3</sub> = 211,854 + 72,000	= 283,854 in lbs
	E <sub>4</sub> = (283,854) • (30)	= 8,515,620 in lbs/h
	We = 283,854 / (0.186) • (10 <sup>2</sup> )	= 15,260.9 lbs

R1 - Select from Model Rating Chart: CA 4 x 6-3

**R2 Radius of Gyration, Horizontal Plane**      **Examples: Packaging Equipment, Pick-and-Place Robots**

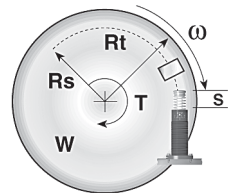


$$\begin{aligned} Wa &= (W) \cdot (k^2) / (Rs^2) \\ V &= (Rs) \cdot (\omega) / 688 \\ F &= T / Rs \\ E_1 &= (0.186) \cdot (Wa) \cdot (V^2) \\ E_2 &= (F) \cdot (s) \\ E_3 &= E_1 + E_2 \\ E_4 &= (E_3) \cdot (C) \\ We &= E_3 / (0.186) \cdot (V^2) \end{aligned}$$

W = 300 lbs	Wa = (300) • (2.5 <sup>2</sup> ) / (25 <sup>2</sup> )	= 3 lbs
k = 2.5 inches	V = (25) • (180) / 688	= 6.54 ft/sec
ω = 180°/sec	F = 9,000 / 25	= 360 lbs
T = 9,000 lbs-in	E <sub>1</sub> = (0.186) • (3) • (6.54 <sup>2</sup> )	= 23.87 in lbs
Rs = 25 inches	E <sub>2</sub> = (360) • (1)	= 360 in lbs
C = 1,200/hour	E <sub>3</sub> = 23.87 + 360	= 383.87 in lbs
s = 1 inch	E <sub>4</sub> = (383.87) • (1,200)	= 460,644 in lbs/h
	We = 383.87 / (0.186) • (6.54 <sup>2</sup> )	= 48.20 lbs

R2 - Select from Model Rating Chart: MC 3325-1 or MA 3325

**R3 Index Table**      **Examples: Index Table, Rotating Work Station**

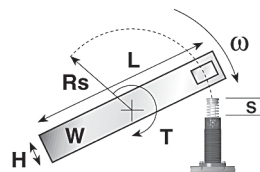


$$\begin{aligned} Wa &= (W \cdot Rt^2) / (2 \cdot Rs^2) \\ V &= (Rs) \cdot (\omega) / 688 \\ F &= T / Rs \\ E_1 &= (0.186) \cdot (Wa) \cdot (V^2) \\ E_2 &= (F) \cdot (s) \\ E_3 &= E_1 + E_2 \\ E_4 &= (E_3) \cdot (C) \\ We &= E_3 / (0.186) \cdot (V^2) \end{aligned}$$

W = 195 lbs	Wa = (195 • 20 <sup>2</sup> ) / (2 • 15 <sup>2</sup> )	= 173.3 lbs
Rt = 20 inches	V = (15) • (85) / 688	= 1.85 ft/sec
ω = 85°/sec	F = 1,700 / 15	= 113.3 lbs
T = 1,700 lbs-in	E <sub>1</sub> = (0.186) • (173.3) • (1.85 <sup>2</sup> )	= 110.3 in lbs
Rs = 15 inches	E <sub>2</sub> = (113.3) • (0.75)	= 85 in lbs
C = 60/hour	E <sub>3</sub> = 110.3 + 85	= 195.3 in lbs
s = .75 inches	E <sub>4</sub> = (195.3) • (60)	= 11,718 in lbs/h
	We = 195.3 / (0.186) • (1.85 <sup>2</sup> )	= 306.8 lbs

R3 - Select from Model Rating Chart: SC 300-4 or MC 225H

**R4 Turnover**      **Examples: Roll-Over Device, Paint Booths, Crate Handling**

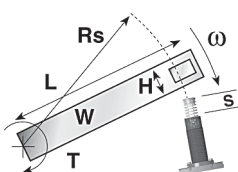


$$\begin{aligned} Wa &= (W) \cdot (H^2 + L^2) / 12 \cdot (Rs^2) \\ V &= (Rs) \cdot (\omega) / 688 \\ F &= T / Rs \\ E_1 &= (0.186) \cdot (Wa) \cdot (V^2) \\ E_2 &= (F) \cdot (s) \\ E_3 &= E_1 + E_2 \\ E_4 &= (E_3) \cdot (C) \\ We &= E_3 / (0.186) \cdot (V^2) \end{aligned}$$

W = 150 lbs	Wa = (150) • (12 <sup>2</sup> + 38 <sup>2</sup> ) / (12 • 12 <sup>2</sup> )	= 125.43 lbs
L = 38 inches	V = (12) • (70) / 688	= 1.22 ft/sec
H = 1 inch	F = 15,000 / 12	= 1,250 lbs
ω = 70°/sec	E <sub>1</sub> = (0.186) • (125.43) • (1.22 <sup>2</sup> )	= 34.72 in lbs
T = 15,000 lbs-in	E <sub>2</sub> = (1,250) • (1)	= 1,250 in lbs
Rs = 12 inches	E <sub>3</sub> = 34.72 + 1,250	= 1,284.72 in lbs
C = 500/hour	E <sub>4</sub> = (1,287) • (500)	= 642,362 in lbs/h
s = 1 inch	We = 1,287 / (0.186) • (1.22 <sup>2</sup> )	= 4,640.6 lbs

R4 - Select from Model Rating Chart: MC 4525-4 or MA 4525

**R5 Uniform Bar, Horizontal Plane**      **Examples: Swinging Beam, Robotic Arm**



$$\begin{aligned} Wa &= (W) \cdot (H^2 + 4 \cdot L^2) / 12 \cdot (Rs^2) \\ V &= (Rs) \cdot (\omega) / 688 \\ F &= T / Rs \\ E_1 &= (0.186) \cdot (Wa) \cdot (V^2) \\ E_2 &= (F) \cdot (s) \\ E_3 &= E_1 + E_2 \\ E_4 &= (E_3) \cdot (C) \\ We &= E_3 / (0.186) \cdot (V^2) \end{aligned}$$

W = 75 lbs	Wa = (75) • (2 <sup>2</sup> + 4 • 30 <sup>2</sup> ) / (12 • 15 <sup>2</sup> )	= 100.1 lbs
L = 30 inches	V = (15) • (180) / 688	= 3.92 ft/sec
H = 2 inches	F = 9,000 / 15	= 600 lbs
ω = 180°/sec	E <sub>1</sub> = (0.186) • (100.1) • (3.92 <sup>2</sup> )	= 286.1 in lbs
T = 9,000 lbs-in	E <sub>2</sub> = (600) • (1)	= 600 in lbs
Rs = 15 inches	E <sub>3</sub> = 286.1 + 600	= 886.1 in lbs
C = 100/hour	E <sub>4</sub> = (886.1) • (100)	= 88,610 in lbs/h
s = 1 inch	We = 886.1 / (0.186) • (3.92 <sup>2</sup> )	= 310 lbs

R5 - Select from Model Rating Chart: MC 4525-2 or MA 4525



For inventory, lead times, and kit lookup, visit [www.pdnplu.com](http://www.pdnplu.com)

## Rotary Sizing Examples

W = Moving Weight (lbs)  
 H = Thickness of Door or Arm (inches)  
 L = Length of Door or Arm (inches)  
 d = Distance from Pivot to c of g (inches)  
 Rs = Mounting Radius of Shock Absorbers (inches)  
 ω = Rotational Speed of Weight (°/sec)

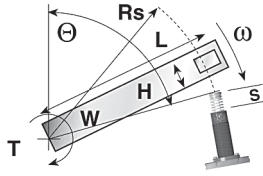
T = Propelling Torque (lbs in)  
 θ = Angle from the Vertical (°)  
 C = Cycles per Hour (/hour)  
 s = Stroke Length of Shock Absorber (inches)  
 F = Propelling Force at Shock Absorber (lbs)

E<sub>1</sub> = Kinetic Energy (in lbs)  
 E<sub>2</sub> = Propelling Force Energy (in lbs)  
 E<sub>3</sub> = Energy per Cycle (in lbs)  
 E<sub>4</sub> = Energy per hour (in lbs/hour)  
 We = Effective Weight (lbs)

## Industrial Shock Absorbers Linear Decelerators

### R6 Uniform Bar, Vertical Plane

### Examples: Cross-Conveyor Transfer, Gantry Walkway



#### FORMULA

$$\begin{aligned} W_a &= (W) \cdot (H^2 + 4 \cdot L^2) / 12 \cdot (R_s^2) \\ V &= (R_s) \cdot (\omega) / 688 \\ F &= [T + 5 \cdot L \cdot W \cdot \sin(\theta)] / R_s \\ E_1 &= (0.186) \cdot (W_a) \cdot (V^2) \\ E_2 &= (F) \cdot (s) \\ E_3 &= E_1 + E_2 \\ E_4 &= (E_3) \cdot (C) \\ W_e &= E_3 / (0.186) \cdot (V^2) \end{aligned}$$

#### EXAMPLE

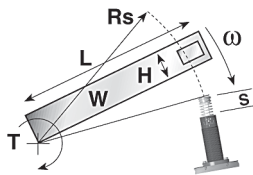
$$\begin{aligned} W &= 5 \text{ lbs} \\ H &= .25 \text{ inches} \\ L &= 6 \text{ inches} \\ \theta &= 87.6^\circ \\ \omega &= 360^\circ/\text{sec} \\ T &= 20 \text{ lbs-in} \\ R_s &= 6 \text{ inches} \\ C &= 1,800/\text{hour} \\ s &= .25 \text{ inches} \end{aligned}$$

$$\begin{aligned} W_a &= (5) \cdot (25^2 + 4 \cdot 6^2) / 12 \cdot (6^2) &= 1.7 \text{ lbs} \\ V &= (6) \cdot (360) / 688 &= 3.1 \text{ ft/sec} \\ F &= [20 + 5 \cdot 6 \cdot 5 \cdot \sin(87.6)] / 6 &= 5.8 \text{ lbs} \\ E_1 &= (0.186) \cdot (1.7) \cdot (3.1^2) &= 3.0 \text{ in lbs} \\ E_2 &= (5.8) \cdot (.25) &= 1.5 \text{ in lbs} \\ E_3 &= 3.3 + 1.5 &= 4.8 \text{ in lbs} \\ E_4 &= (4.8) \cdot (1,800) &= 8,100 \text{ in lbs/h} \\ W_e &= 4.5 / (0.186) \cdot (3.1^2) &= 2.5 \text{ lbs} \end{aligned}$$

R6 - Select from Model Rating Chart: MC 25L

### R7 Door, Horizontal Plane

### Examples: Cabinet Doors, Machine Enclosures



$$\begin{aligned} W_a &= (W) \cdot (H^2 + L^2) / (3 \cdot R_s^2) \\ V &= (R_s) \cdot (\omega) / 688 \\ F &= T / R_s \\ E_1 &= (0.186) \cdot (W_a) \cdot (V^2) \\ E_2 &= (F) \cdot (s) \\ E_3 &= E_1 + E_2 \\ E_4 &= (E_3) \cdot (C) \\ W_e &= E_3 / (0.186) \cdot (V^2) \end{aligned}$$

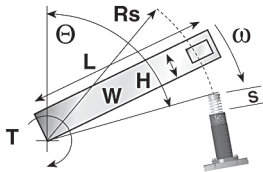
$$\begin{aligned} W &= 120 \text{ lbs} \\ H &= 1 \text{ inch} \\ L &= 42 \text{ inches} \\ \omega &= 60^\circ/\text{sec} \\ T &= 1,800 \text{ lbs-in} \\ R_s &= 10 \text{ inches} \\ C &= 4/\text{hour} \\ s &= .5 \text{ inches} \end{aligned}$$

$$\begin{aligned} W_a &= (120) \cdot (1^2 + 42^2) / (3 \cdot 10^2) &= 706 \text{ lbs} \\ V &= (10) \cdot (60) / 688 &= .9 \text{ ft/sec} \\ F &= 1,800 / 10 &= 180 \text{ lbs} \\ E_1 &= (0.186) \cdot (706) \cdot (.9^2) &= 106.4 \text{ in lbs} \\ E_2 &= (180) \cdot (.5) &= 90 \text{ in lbs} \\ E_3 &= 106.4 + 90 &= 196.4 \text{ in lbs} \\ E_4 &= (196.4) \cdot (4) &= 785 \text{ in lbs/h} \\ W_e &= 196.4 / (0.186) \cdot (.9^2) &= 1,303.6 \text{ lbs} \end{aligned}$$

R7 - Select from Model Rating Chart: MC 225H2

### R8 Door, Vertical Plane

### Examples: Hatches, Lids, Hoods



$$\begin{aligned} W_a &= (W) \cdot (H^2 + L^2) / (3 \cdot R_s^2) \\ V &= (R_s) \cdot (\omega) / 688 \\ F^* &= [T + 5 \cdot L \cdot W \cdot \sin(\theta)] / R_s \\ E_1 &= (0.186) \cdot (W_a) \cdot (V^2) \\ E_2 &= (F) \cdot (s) \\ E_3 &= E_1 + E_2 \\ E_4 &= (E_3) \cdot (C) \\ W_e &= E_3 / (0.186) \cdot (V^2) \end{aligned}$$

$$\begin{aligned} W &= 60 \text{ lbs} \\ H &= 1 \text{ inch} \\ L &= 10 \text{ inches} \\ \theta &= 150^\circ \\ \omega &= 200^\circ/\text{sec} \\ T &= 45 \text{ lbs-in} \\ R_s &= 10 \text{ inches} \\ C &= 1,900/\text{hour} \\ s &= .63 \text{ inches} \end{aligned}$$

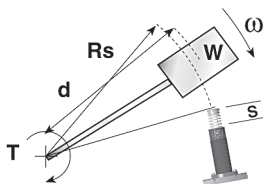
$$\begin{aligned} W_a &= (60) \cdot (1^2 + 10^2) / (3 \cdot 10^2) &= 20.2 \text{ lbs} \\ V &= (10) \cdot (200) / 688 &= 2.9 \text{ ft/sec} \\ F &= [45 + 5 \cdot 10 \cdot 60 \cdot \sin(150)] / 10 &= 19.5 \text{ lbs} \\ E_1 &= (0.186) \cdot (20.2) \cdot (2.9^2) &= 31.6 \text{ in lbs} \\ E_2 &= (19.5) \cdot (0.63) &= 12.3 \text{ in lbs} \\ E_3 &= 34 + 12.3 &= 43.9 \text{ in lbs} \\ E_4 &= (43.9) \cdot (1,900) &= 83,382 \text{ in lbs/h} \\ W_e &= 43.9 / (0.186) \cdot (2.9^2) &= 28.1 \text{ lbs} \end{aligned}$$

\*Force is approximate

R8 - Select from Model Rating Chart: SC 190-2

### R9 Weight at Radius, Horizontal Plane

### Examples: Circuit Breakers, Swinging Gates



$$\begin{aligned} W_a &= (W) \cdot (d^2) / (R_s^2) \\ V &= (R_s) \cdot (\omega) / 688 \\ F &= T / R_s \\ E_1 &= (0.186) \cdot (W_a) \cdot (V^2) \\ E_2 &= (F) \cdot (s) \\ E_3 &= E_1 + E_2 \\ E_4 &= (E_3) \cdot (C) \\ W_e &= E_3 / (0.186) \cdot (V^2) \end{aligned}$$

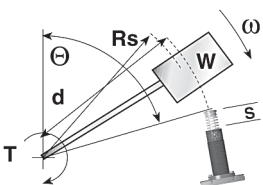
$$\begin{aligned} W &= 40 \text{ lbs} \\ d &= 8 \text{ inches} \\ \omega &= 110^\circ/\text{sec} \\ T &= 150 \text{ lbs-in} \\ R_s &= 7 \text{ inches} \\ C &= 1,500/\text{hour} \\ s &= .5 \text{ inches} \end{aligned}$$

$$\begin{aligned} W_a &= (40) \cdot (8^2) / (7^2) &= 52 \text{ lbs} \\ V &= (7) \cdot (110) / 688 &= 1.1 \text{ ft/sec} \\ F &= 150 / 7 &= 21 \text{ lbs} \\ E_1 &= (0.186) \cdot (52) \cdot (1.1^2) &= 11.7 \text{ in lbs} \\ E_2 &= (21) \cdot (.5) &= 10.5 \text{ in lbs} \\ E_3 &= 11.7 + 10.5 &= 22.2 \text{ in lbs} \\ E_4 &= (22.2) \cdot (1,500) &= 33,300 \text{ in lbs/h} \\ W_e &= 22.2 / (0.186) \cdot (1.1^2) &= 98.6 \text{ lbs} \end{aligned}$$

R9 - Select from Model Rating Chart: MC 150H

### R10 Weight at Radius, Vertical Plane

### Examples, Impact Testers, Pendulums



$$\begin{aligned} W_a &= (W) \cdot (d^2) / (R_s^2) \\ V &= (R_s) \cdot (\omega) / 688 \\ F^* &= [T + W \cdot d \cdot \sin(\theta)] / R_s \\ E_1 &= (0.186) \cdot (W_a) \cdot (V^2) \\ E_2 &= (F) \cdot (s) \\ E_3 &= E_1 + E_2 \\ E_4 &= (E_3) \cdot (C) \\ W_e &= E_3 / (0.186) \cdot (V^2) \end{aligned}$$

$$\begin{aligned} W &= 40 \text{ lbs} \\ d &= 8 \text{ inches} \\ \theta &= 90^\circ \\ \omega &= 110^\circ/\text{sec} \\ T &= 150 \text{ lbs-in} \\ R_s &= 7 \text{ inches} \\ C &= 1,500/\text{hour} \\ s &= .5 \text{ inches} \end{aligned}$$

$$\begin{aligned} W_a &= (40) \cdot (8^2) / (7^2) &= 52 \text{ lbs} \\ V &= (7) \cdot (110) / 688 &= 1.1 \text{ ft/sec} \\ F &= [150 + 40 \cdot 8 \cdot \sin(90)] / 7 &= 67 \text{ lbs} \\ E_1 &= (0.186) \cdot (52) \cdot (1.1^2) &= 11.7 \text{ in lbs} \\ E_2 &= (67) \cdot (.5) &= 33.5 \text{ in lbs} \\ E_3 &= 11.7 + 33.5 &= 45.2 \text{ in lbs} \\ E_4 &= (45.2) \cdot (1,500) &= 67,800 \text{ in lbs/h} \\ W_e &= 45.2 / (1.1^2) &= 200.8 \text{ lbs} \end{aligned}$$

\*Force is approximate

R10- Select from Model Rating Chart: MC 150H



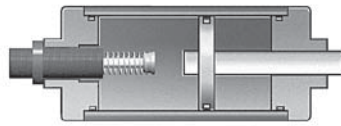
For inventory, lead time, and kit lookup, visit [www.pdnplu.com](http://www.pdnplu.com)

M11

**Parker Hannifin Corporation**  
 Pneumatic Division  
 Richland, Michigan  
[www.parker.com/pneumatics](http://www.parker.com/pneumatics)

**1. Shock Absorbers for Pneumatic Cylinders**

- For:
- optimum deceleration
  - higher speeds
  - smaller cylinders
  - reduced air consumption
  - smaller valves and pipework

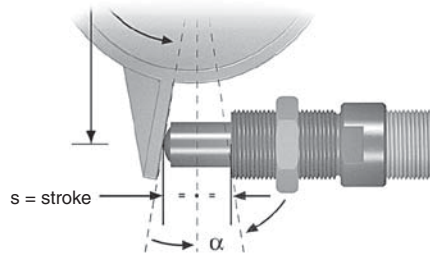


Example: MA 3350 M-Z  
-Z = cylinder mounting

With heavy loads or high velocities normal cylinder cushions are often overloaded. This causes shock loading leading to premature cylinder failure or excessive maintenance.

Using oversized cylinders to withstand this shock loading is not the best solution since this considerably increases air consumption and costs.

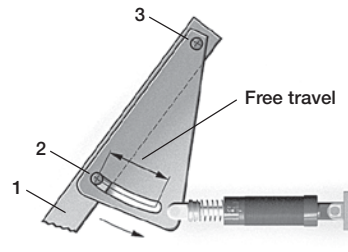
**2. Side Load Adapter for High Side Load Angles**



The side loading is removed from the shock absorber piston rod leading to considerably longer life. Wherever possible mount shock absorber so that impacting face is perpendicular to shock absorber axis half way through stroke.

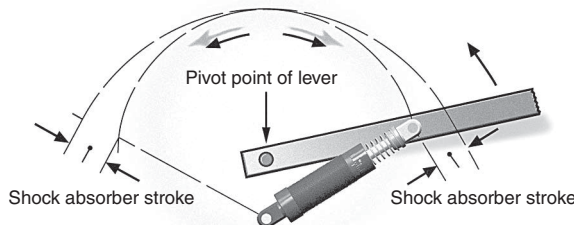
See pages L46 and L47 for more details.

**3. Undamped Free Travel with Damped End Extension**



The lever 1 swings with the pin 2 in a slotted hole around pivot point 3. The lever is smoothly decelerated at the extreme end of its travel.

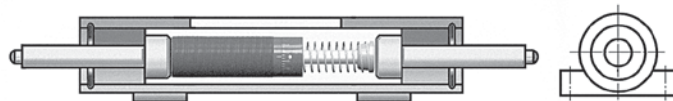
**4. One Shock Absorber for Both Ends of Travel**



It is possible to use only one shock absorber for both end positions by using different pivot points as shown.

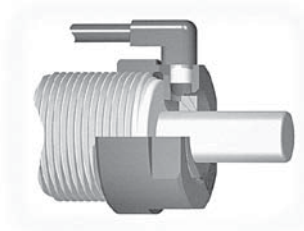
**Tip:** Leave approx. 0.06 in (1.5 mm) of shock absorber stroke free at each end of travel.

**5. Double Acting Shock Absorber**



With a little additional work a normal unidirectional shock absorber can be converted to work in 2 directions by using a mechanism as shown.

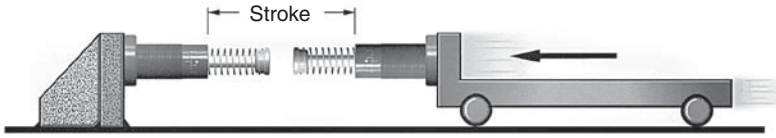
**6. Air Bleed Collar**



By using this air bleed collar the operating lifetime of shock absorbers in aggressive environments can be considerably increased. The adapter protects the shock absorber seals from cutting fluids, cleaning agents, cooking oils etc. by using a low pressure air bleed.

Available for select shock absorbers.

**7. Double Stroke Length**



50% lower reaction force (Q) 50% lower deceleration (a)

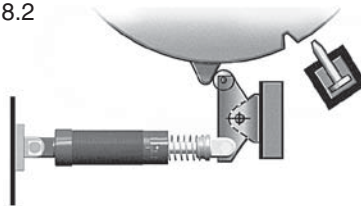
By driving 2 shock absorbers against one another 'nose-to-nose', the effective stroke length can be doubled.

**8. Ride Over Latch**

8.1



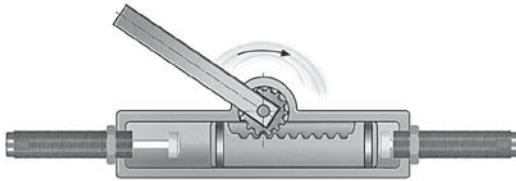
8.2



8.1 The latch absorbs the kinetic energy so that the object contacts the fixed stop gently.

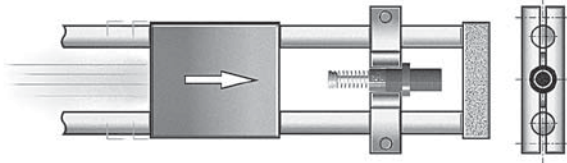
8.2 The latch absorbs the rotational energy of the turntable etc. The turntable can then be held in the datum position with a lock bolt or similar device.

**9. Rotary Actuator or Rack and Pinion Drive**



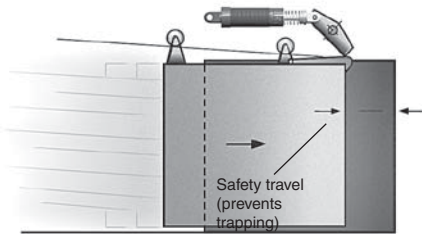
The use of shock absorbers allows higher operating speeds and weights as well as protecting the drive mechanism and housing from shock loads.

**10. Adjustable Stop Clamp e.g. for Handling Equipment**



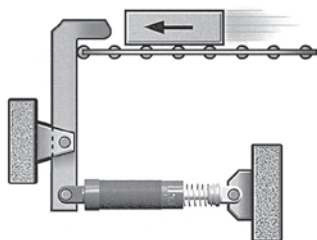
The gentle deceleration of shock absorbers makes the use of adjustable stop clamps possible and removes any chance of the clamp slipping. The kinetic energy is completely removed before the mechanical stop is reached thus making high index speeds possible.

**11. Ride-Over Latch e.g. Fire Door**



The fire door travels quickly until it reaches the lever. It is then gently decelerated by the lever mounted shock absorber and closes without shock or danger to personnel.

**12. Increasing Stroke Length Mechanically**



By means of a lever the effective stroke length can be increased and mounting space to the left reduced.

Model Rating Charts

Industrial Shock Absorbers are rated by capacity for the purpose of selecting the proper unit for an application's energy requirements. Ratings are determined by the effective weight that the shock absorber can stop and the energy it can absorb per cycle and per hour. These ratings relate to the mechanical and thermal capacity of a shock absorber because the mechanical energy is converted to heat and dissipated.

Self-Compensating Models

Model Number	Stroke inches 1 inch = 25.4 mm	E3 Max Energy per Cycle, inch lbs 1 in lb = .11 Nm	We Effective Weight lbs, 1 lb = .45 kg	E4 Max Energy per hour, in lbs/hour 1 in lb/hour = .11 Nm/hour			Product Catalog Page
				Self-Contained	A/O Tank	A/O Re-circulating	
MC 9-1	0.20	9	1.35-7.0	18,000	N/A	N/A	L16
MC 9-2	0.20	9	1.75-9.0	18,000			L16
MC 10L	0.20	4	0.75-6.0	35,000	N/A	N/A	L16
MC 10H	0.20	7	1.5-11	35,000			L16
MC 25L	0.25	20	1.5-5	120,000			L16
MC 25	0.25	20	4-12	120,000	N/A	N/A	L16
MC 25H	0.25	20	10-30	120,000			L16
MC 75-1	0.40	75	0.5-2.5	250,000			L16
MC 75-2	0.40	75	2-14	250,000	N/A	N/A	L16
MC 75-3	0.40	75	6-80	250,000			L16
MC 150	0.50	150	2-22	300,000			L18
MC 150H	0.50	150	20-200	300,000	N/A	N/A	L18
MC 150H2	0.50	150	150-450	300,000			L18
MC 225	0.50	225	5-55	400,000			L18
MC 225H	0.50	225	50-500	400,000	N/A	N/A	L18
MC 225H2	0.50	225	400-2,000	400,000			L18
MC 600	1.00	600	20-300	600,000			L18
MC 600H	1.00	600	250-2,500	600,000	N/A	N/A	L18
MC 600H2	1.00	600	880-5,000	600,000			L18
SC 190-1	0.63	225	3-15	300,000			L20
SC 190-2	0.63	225	8-40	300,000	N/A	N/A	L20
SC 190-3	0.63	225	20-100	300,000			L20
SC 190-4	0.63	225	50-225	300,000			L20
SC 300-1	0.75	300	3-18	400,000			L20
SC 300-2	0.75	300	10-60	400,000			L20
SC 300-3	0.75	300	30-180	400,000			L20
SC 300-4	0.75	300	70-450	400,000			L20
SC 300-5	0.59	650	25-100	400,000	N/A	N/A	L22
SC 300-6	0.59	650	75-300	400,000			L22
SC 300-7	0.59	650	200-400	400,000			L22
SC 300-8	0.59	620	300-1,500	400,000			L22
SC 300-9	0.59	620	700-4,300	400,000			L22
SC 650-1	1.00	650	17-100	600,000			L20
SC 650-2	1.00	650	50-300	600,000			L20
SC 650-3	1.00	650	150-900	600,000			L20
SC 650-4	1.00	650	450-2,600	600,000			L20
SC 650-5	0.91	1,860	50-250	600,000	N/A	N/A	L22
SC 650-6	0.91	1,860	200-800	600,000			L22
SC 650-7	0.91	1,860	700-2,400	600,000			L22
SC 650-8	0.91	1,860	1,700-5,800	600,000			L22
SC 650-9	0.91	1,860	4,000-14,000	600,000			L22
SC 925-1	1.58	975	30-200	800,000			L20
SC 925-2	1.58	975	90-600	800,000	N/A	N/A	L20
SC 925-3	1.58	975	250-1,600	800,000			L20
SC 925-4	1.58	975	750-4,600	800,000			L20
MC 3325-1			20-80				
MC 3325-2	0.91	1,350	68-272	670,000	1,100,000	1,500,000	L26, L28
MC 3325-3			230-920				
MC 3325-4			780-3,120				
MC 3350-1			40-160				
MC 3350-2	1.91	2,700	136-544	760,000	1,200,000	1,600,000	L26, L28
MC 3350-3			460-1,840				
MC 3350-4			1,560-6,240				
MC 3625-1			20-80				
MC 3625-2	0.91	1,350	68-272	670,000	1,100,000	1,500,000	L26, L28
MC 3625-3			230-920				
MC 3625-4			780-3,120				
MC 3650-1			40-160				
MC 3650-2	1.91	2,700	136-544	760,000	1,200,000	1,600,000	L26, L28
MC 3650-3			460-1,840				
MC 3650-4			1,560-6,240				
MC 4525-1			50-200				
MC 4525-2	0.91	3,000	170-680	950,000	1,400,000	1,700,000	L26, L30
MC 4525-3			575-2,300				
MC 4525-4			1,950-7,800				
MC 4550-1			100-400				
MC 4550-2	1.91	6,000	340-1,360	1,000,000	1,700,000	2,200,000	L26, L30
MC 4550-3			1,150-4,600				
MC 4550-4			3,900-15,600				
MC 4575-1			150-600				
MC 4575-2	2.91	9,000	510-2,040	1,300,000	2,000,000	2,500,000	L22, L30
MC 4575-3			1,730-6,920				
MC 4575-4			5,850-23,400				
MC 6450-1			300-1,200				
MC 6450-2	1.91	15,000	1,020-4,080	1,300,000	2,600,000	3,400,000	L26, L32
MC 6450-3			3,460-13,840				
MC 6450-4			11,700-46,800				
MC 64100-1			600-2,400				
MC 64100-2	3.91	30,000	2,040-8,160	1,700,000	3,400,000	4,400,000	L26, L32
MC 64100-3			6,920-27,680				
MC 64100-4			23,400-93,600				
MC 64150-1			900-3,600				
MC 64150-2	5.91	45,000	3,060-12,240	2,200,000	4,400,000	5,700,000	L26, L32
MC 64150-3			10,380-41,520				
MC 64150-4			35,100-140,400				

Industrial Shock Absorbers



For inventory, lead times, and kit lookup, visit [www.pdnplu.com](http://www.pdnplu.com)

M14

Parker Hannifin Corporation  
Pneumatic Division  
Richland, Michigan  
[www.parker.com/pneumatics](http://www.parker.com/pneumatics)



**Self-Compensating Models Continued**

Model Number	Stroke inches 1 inch = 25.4 mm	E3 Max Energy per Cycle, inch lbs 1 in lb = .11 Nm	We Effective Weight lbs, 1 lb = .45 kg	E4 Max Energy per hour, in lbs/hour 1 in lb/hour = .11 Nm/hour			Product Catalog Page
				Self-Contained	A/O Tank	A/O Re-circulating	
CA 2x2-1 CA 2x2-2 CA 2x2-3 CA 2x2-4	2.00	32,000	1,600-4,800 4,000-12,000 10,000-30,000 25,000-75,000	9,600,000	12,000,000	15,600,000	L38, L40
CA 2x4-1 CA 2x4-2 CA 2x4-3 CA 2x4-4	4.00	64,000	3,200-9,600 8,000-24,000 20,000-60,000 50,000-150,000	12,000,000	15,000,000	19,500,000	L38, L40
CA 2x6-1 CA 2x6-2 CA 2x6-3 CA 2x6-4	6.00	96,000	4,800-14,400 12,000-36,000 30,000-90,000 75,000-225,000	14,400,000	18,000,000	23,500,000	L38, L40
CA 2x8-1 CA 2x8-2 CA 2x8-3 CA 2x8-4	8.00	128,000	6,400-19,200 16,000-48,000 40,000-120,000 100,000-300,000	16,800,000	21,000,000	27,000,000	L38, L40
CA 2x10-1 CA 2x10-2 CA 2x10-3 CA 2x10-4	10.00	160,000	8,000-24,000 20,000-60,000 50,000-150,000 125,000-375,000	19,200,000	24,000,000	31,000,000	L38, L40
CA 3x5-1 CA 3x5-2 CA 3x5-3 CA 3x5-4	5.00	125,000	6,400-19,200 16,000-48,000 40,000-120,000 100,000-300,000	20,000,000	25,000,000	32,500,000	L38, L40
CA 3x8-1 CA 3x8-2 CA 3x8-3 CA 3x8-4	8.00	200,000	10,240-30,720 25,600-76,800 64,000-192,000 160,000-480,000	32,000,000	40,000,000	52,000,000	L38, L40
CA 3x12-1 CA 3x12-2 CA 3x12-3 CA 3x12-4	12.00	300,000	15,360-46,080 38,400-115,200 96,000-288,000 240,000-720,000	48,000,000	60,000,000	78,000,000	L38, L40
CA 4x6-3 CA 4x6-5 CA 4x6-7	6.00 6.00 6.00	420,000 420,000 420,000	8,000-19,000 19,000-41,000 41,000-94,000	27,000,000 27,000,000 27,000,000	45,000,000 45,000,000 45,000,000	58,000,000 58,000,000 58,000,000	L38, L44 L38, L44 L38, L44
CA 4x8-3 CA 4x8-5 CA 4x8-7	8.00 8.00 8.00	560,000 560,000 560,000	11,000-25,000 25,000-55,000 55,000-125,000	30,000,000 30,000,000 30,000,000	50,000,000 50,000,000 50,000,000	65,000,000 65,000,000 65,000,000	L38, L44 L38, L44 L38, L44
CA 4x16-3 CA 4x16-5 CA 4x16-7	16.00 16.00 16.00	1,120,000 1,120,000 1,120,000	22,000-50,000 50,000-110,000 110,000-250,000	50,000,000 50,000,000 50,000,000	85,000,000 85,000,000 85,000,000	110,000,000 110,000,000 110,000,000	L38, L44 L38, L44 L38, L44

**Adjustable Models**

MA 35	0.40	35	13-125	53,000			L24
MA 150	0.50	150	2-200	300,000			L24
MA 225	0.75	225	5-500	400,000	N/A	N/A	L24
MA 600	1.00	600	20-3,000	600,000			L24
MA 900	1.58	900	30-4,500	800,000			L24
MA 3325	0.91	1,500	20-3,800	670,000	1,100,000	1,500,000	L27
MA 3350	1.91	3,000	28-5,400	760,000	1,200,000	1,600,000	L27
MA 3625	0.91	1,500	20-3,800	670,000	1,100,000	1,500,000	L27
MA 3650	1.91	3,000	28-5,400	760,000	1,200,000	1,600,000	L27
MA 4525	0.91	3,450	95-22,000	950,000	1,400,000	1,700,000	L27, L30
MA 4550	1.91	6,900	150-32,000	1,000,000	1,700,000	2,200,000	L27, L30
MA 4575	2.91	10,350	155-33,000	1,300,000	2,000,000	2,500,000	L27, L30
MA 6450	1.91	18,000	480-110,000	1,300,000	2,600,000	3,400,000	L27, L32
MA 64100	3.91	36,000	600-115,000	1,700,000	3,400,000	4,400,000	L27, L32
MA 64150	5.91	54,000	730-175,000	2,200,000	4,400,000	5,700,000	L27, L32
1-1/2x2	2.00	16,000	430-70,000	3,200,000	4,000,000	5,200,000	L36
1-1/2x3-1/2	3.50	28,000	480-80,000	5,600,000	7,000,000	9,100,000	L36
1-1/2x5	5.00	40,000	500-90,000	8,000,000	10,000,000	13,000,000	L36
1-1/2x6-1/2	6.50	52,000	680-100,000	10,400,000	13,000,000	17,000,000	L36
A 2x2	2.00	32,000	560-170,000	9,600,000	12,000,000	15,600,000	L39, L40
A 2x4	4.00	80,000	510-160,000	12,000,000	15,000,000	19,500,000	L39, L40
A 2x6	6.00	120,000	570-190,000	14,400,000	18,000,000	23,500,000	L39, L40
A 2x8	8.00	170,000	580-200,000	16,800,000	21,000,000	27,000,000	L39, L40
A 2x10	10.00	210,000	720-250,000	19,200,000	24,000,000	31,000,000	L39, L40
A 3x5	5.00	140,000	1,050-340,000	20,000,000	25,000,000	32,500,000	L39, L40
A 3x8	8.00	250,000	1,200-400,000	32,000,000	40,000,000	52,000,000	L39, L40
A 3x12	12.00	390,000	1,350-450,000	48,000,000	60,000,000	78,000,000	L39, L40

**Low Velocity Adjustable Models**

ML 3325	0.91	1,500	.05-1.5	670,000	1,100,000	1,500,000	L27
ML 3350	1.91	3,000	.05-1.5	760,000	1,200,000	1,600,000	L27
ML 3625	0.91	1,500	.05-1.5	670,000	1,100,000	1,500,000	L27
ML 3650	1.91	3,000	.05-1.5	760,000	1,200,000	1,600,000	L27
ML 4525	0.91	3,450	.05-1.5	950,000	1,400,000	1,700,000	L27, L30
ML 4550	1.91	6,900	.05-1.5	1,000,000	1,700,000	2,200,000	L27, L30
ML 6425	0.91	9,000	.05-1.5	1,100,000	2,200,000	2,900,000	L27, L32
ML 6450	1.91	18,000	.05-1.5	1,300,000	2,600,000	3,400,000	L27, L32



For inventory, lead time, and kit lookup, visit [www.pdnplu.com](http://www.pdnplu.com)

M15

**Parker Hannifin Corporation**  
Pneumatic Division  
Richland, Michigan  
[www.parker.com/pneumatics](http://www.parker.com/pneumatics)

**Miniature Shock Absorbers MC 9 to MC 75 - Self-Compensating**

Miniature Shock Absorbers are self-contained hydraulic units. The MC 9 to MC 75 model range has a very short overall length and low return force. Its small size allows for high energy absorption in confined spaces, while the wide effective weight ranges accommodate a variety of load conditions. With threaded outer bodies and multiple accessories, MC models can be mounted in numerous configurations.

**Applications include:**

Small linear slides, material handling and packaging equipment, small robotics, office and medical equipment, as well as instrumentation.



**Operating information**

**Impact velocity range:**

MC 9:	0.5 to 6 ft/sec (0.15 to 1.8 m/sec)
MC 10:	0.5 to 5 ft/sec (0.15 to 1.5 m/sec)
MC 25:	0.5 to 8 ft/sec (0.15 to 2.4 m/sec)
MC 75:	0.5 to 12 ft/sec (0.15 to 3.66 m/sec)

**Operating temperature:**

MC 9 and MC 10:	14°F to 158°F (-10°C to 70°C)
MC 25:	32°F to 150°F (0°C to 66°C)
MC 75:	32°F to 150°F (0°C to 66°C)

**Ordering information – Miniature MC series, self-compensating**

<b>MC</b>	<b>75</b>	<b>-</b>	<b>1</b>	<b>□</b>
MC series	Model number	Mounting thread	Effective weight	Button options
	9	MC9	MC9	MC9 & MC10
	10	M M6 x 1.0 metric	1 Light	Standard, no button
	25	MC10	2 Medium	-B Acetyl button
	75	M M8 x 1.0 metric	MC10	MC25 & MC75
		E M8 x 0.75 metric	L Light range	Standard, with button
		MC25	H Heavy range	-NB *No button, short rod
		Standard (UNEF)	MC25	-880 No button, standard rod
		M Metric	L Light range	
		MC75	Standard range	
		Standard (UNEF)	H Heavy range	
		M Metric	MC75	
			1 Light	
			2 Medium	
			3 Heavy	

\* Consult factory for dimensional details.

Stroke inches 1 inch = 25.4 mm	E3 max. energy per cycle, inch lbs 1 in lb = .11 Nm	We effective weight lbs, 1 lb = .45 kg	E4 max. energy per hour, in lbs/hour 1 in lb/hour = .11 Nm/hour			Model number
			Self-contained	A/O tank	A/O Re-circulating	
0.20	9	1.35-7.0	18,000	N/A	N/A	MC 9M-1
0.20	9	1.75-9.0	18,000	N/A	N/A	MC 9M-2
0.20	4	0.75-6.0	35,000	N/A	N/A	MC 10L
0.20	7	1.5-11	35,000	N/A	N/A	MC 10H
0.25	20	1.5-5	120,000	N/A	N/A	MC 25L
0.25	20	4-12	120,000	N/A	N/A	MC 25
0.25	20	10-30	120,000	N/A	N/A	MC 25H
0.40	75	0.5-2.5	250,000	N/A	N/A	MC 75-1
0.40	75	2-14	250,000	N/A	N/A	MC 75-2
0.40	75	6-80	250,000	N/A	N/A	MC 75-3



For inventory, lead times, and kit lookup, visit [www.pdnplu.com](http://www.pdnplu.com)

M16

**Parker Hannifin Corporation**  
Pneumatic Division  
Richland, Michigan  
[www.parker.com/pneumatics](http://www.parker.com/pneumatics)

## Miniature Shock Absorbers

## Industrial Shock Absorbers MC 9 to MC 75 Series, Self-Compensating

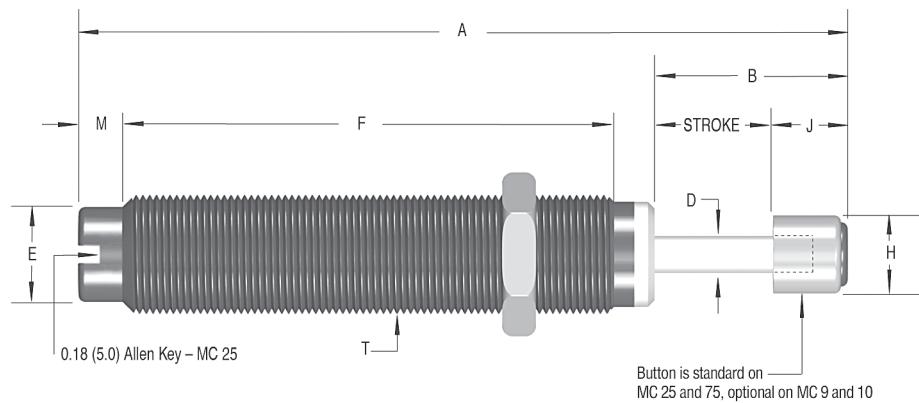
### Specifications

- Mechanical stop: Integral mechanical stop built into front of units.
- Oil type – Silicone
- Materials – Steel body with black oxide finish.  
Hardened stainless steel piston rod.
- Technical data applies to standard and metric threaded models.
- Maximum side load depends on application.  
For additional information contact The Pneumatic Division.
- Lock nut included with each shock absorber.

**Note:** All dimensions and tolerance values listed in this catalog are nominal and subject to change without notice.

Model	Return Force lbs (N)	Return Time sec	Shipping Weight lbs (kg)
MC 9M-1 MC 9M-2	0.31 - 0.85 (1.38-3.78)	0.30	0.01 (0.004)
MC 10L MC 10H	0.5 - 1.0 (2.22 - 4.45)	0.20	0.02 (0.01)
MC 25L MC 25 MC 25H	0.8 - 1.7 (3.56 - 7.56)	0.20	0.06 (0.03)
MC 75-1 MC 75-2 MC 75-3	1.0 - 2.5 (4.45 - 11.12)	0.30	0.09 (0.04)

### Miniature Shock Absorbers MC 9 to MC 75 Self-Compensating



Model	Stroke	A	B	D	E	F	H	J	M	T
MC 9M	.20 (5.0)	1.42 (36.0)	.40 (10.0)	.08 (2.0)	.20 (5.0)	.83 (21.1)	.19 (4.7)	.20 (5.0)	.10 (2.5)	M6x0.5
MC 10E MC 10M	.20 (5.0)	1.52 (38.6)	.40 (10.0)	.08 (2.0)	.25 (6.4)	.83 (21.1)	.19 (4.7)	.20 (5.0)	.19 (4.8)	M8x0.75 M8x1
MC 25 MC 25M	.26 (6.6)	2.27 (57.7)	.57 (14.5)	.13 (3.3)	.33 (8.4)	1.3 (33.0)	.30 (7.6)	.32 (8.1)	.20 (5.0)	3/8-32 UNEF M10x1
MC 75 MC 75M	.40 (10.2)	2.76 (70.1)	.72 (18.1)	.13 (3.3)	.41 (10.4)	1.74 (44.2)	.30 (7.6)	.32 (8.1)	.18 (4.6)	1/2-20 UNF M12x1

Inches (mm)

Industrial Shock  
Absorbers

**M**



For inventory, lead time, and kit lookup, visit [www.pdnplu.com](http://www.pdnplu.com)

M17

**Parker Hannifin Corporation**  
Pneumatic Division  
Richland, Michigan  
[www.parker.com/pneumatics](http://www.parker.com/pneumatics)

**Miniature Shock Absorbers MC 150 to MC 600 - Self-Compensating**

Miniature Shock Absorbers MC 150 to MC 600 model range, feature a hermetically sealed rolling diaphragm seal system that provides the highest possible cycle lifetime and an extremely low rod return force. These models can be directly mounted into the end cover of pneumatic cylinders to provide superior damping compared to normal cylinder cushions. Use of the optional stop collar is recommended to provide a positive mechanical stop. By adding the optional side load adapter (metric threaded models only), it is possible to accept side loads up to 25° from the axis.

**Applications for the durable MC Series include:**

Material handling, medium robotics, machine tools, pick and place systems, as well as packaging equipment.



**Operating information**

Impact velocity range:	0.26 to 19.7 ft/sec (0.08 to 6 m/sec)
Operating temperature:	32°F to 150°F (0°C to 66°C)

**Note:** MC 150 to MC 600 models may be mounted into pressure chambers of pneumatic actuators.

**Ordering information – Miniature MC series, self-compensating**

<b>MC</b>	<b>225</b>	□	□	□
MC series	Model number	Mounting thread		Effective weight
	150		Standard (UNF)	<b>MC150, MC225, MC600</b>
	225	<b>M</b>	Metric	Standard range
	600	<b>ME*</b>	Fine metric	<b>H</b> Heavy range
		<b>ML**</b>	Course metric	<b>H2</b> Extra heavy range
				Button options
				Standard, no button
				<b>-B</b> Acetyl button
				<b>-BS</b> Steel button

\*MC 150 only \*\*MC 600 only

Stroke inches 1 inch = 25.4 mm	E3 max. energy per cycle, inch lbs 1 in lb = .11 Nm	We effective weight lbs, 1 lb = .45 kg	E4 max. energy per hour, in lbs/hour 1 in lb/hour = .11 Nm/hour			Model number
			Self-contained	A/O tank	A/O Re-circulating	
0.50	150	2-22	300,000			<b>MC 150</b>
0.50	150	20-200	300,000	N/A	N/A	<b>MC 150H</b>
0.50	150	150-450	300,000			<b>MC 150H2</b>
0.50	225	5-55	400,000			<b>MC 225</b>
0.50	225	50-500	400,000	N/A	N/A	<b>MC 225H</b>
0.50	225	400-2,000	400,000			<b>MC 225H2</b>
1.00	600	20-300	600,000			<b>MC 600</b>
1.00	600	250-2,500	600,000	N/A	N/A	<b>MC 600H</b>
1.00	600	880-5,000	600,000			<b>MC 600H2</b>

Industrial Shock Absorbers



For inventory, lead times, and kit lookup, visit [www.pdnplu.com](http://www.pdnplu.com)

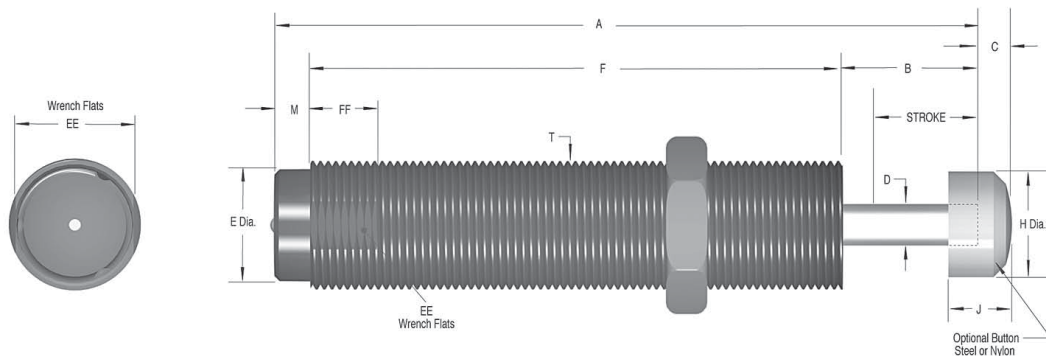
**Specifications**

- Mechanical stop – Must be provided 0.02 to 0.04 inch (0.5 to 1 mm) before end of stroke.
  - Oil type \_ Silicone
  - Materials –
    - Steel body - with black oxide finish.
    - Piston rod - hardened stainless steel
    - Rolling seal - EPDM
- Note:** seal not compatible with petroleum based fluids. If unit to be used in contact with such fluids specify neoprene rolling seal. Consider the SC2 Series as an alternative.
- To prevent damage to the rolling seal in MC 150, 225 and 600 models, do not twist or turn the piston rod.
  - Technical data applies to standard and metric threaded models.
  - Maximum side load depends on application. For additional information contact The Pneumatic Division.
  - Lock nut included with each shock absorber.

**Note:** MC 150 to MC 600 models may be mounted into pressure chambers of pneumatic actuators.

Model	Return Force lbs (N)	Return Time sec	Shipping Weight lbs (kg)
<b>MC 150</b> <b>MC 150H</b> <b>MC 150H2</b>	0.70 - 1.20 (3.11 - 5.34)	0.40	.12 (0.05)
<b>MC 225</b> <b>MC 225H</b> <b>MC 225H2</b>	1.00 - 1.50 (4.45 - 6.67)	0.30	.34 (0.15)
<b>MC 600</b> <b>MC 600H</b> <b>MC 600H2</b>	1.00 - 2.00 (4.45 - 8.90)	0.60	.57 (0.26)

**Miniature Shock Absorbers MC 150 to MC 600  
Self-Compensating**



Model	Stroke	A	B	C	D	E	F	H	J	M	T	EE	FF
<b>MC 150</b> <b>MC 150M</b> <b>MC 150ME</b>	.50 (12.8)	3.41 (86.6)	.69 (17.5)	.18 (4.6)	.19 (4.8)	.46 (11.6)	2.44 (62.0)	.47 (11.9)	.39 (9.9)	.28 (7.1)	9/16-18 UNF M14x1.5 M14x1	.500 (12.0)	.50 (12.7)
<b>MC 225</b> <b>MC 225M</b> <b>MC 225ME</b>	.50 (12.8)	3.81 (96.8)	.69 (17.5)	.16 (4.1)	.25 (6.4)	.66 (16.7)	2.84 (72.1)	.66 (16.8)	.36 (9.1)	.28 (7.1)	3/4-16 UNF M20x1.5 M20x1	.687 (18.0)	.50 (12.7)
<b>MC 600</b> <b>MC 600M</b> <b>MC 600ML</b>	1.00 (25.4)	5.58 (141.8)	1.24 (31.6)	.23 (5.8)	.31 (7.9)	.87 (22.0)	4.06 (103.1)	.89 (22.6)	.47 (11.9)	.28 (7.1)	1-12 UNF M25x1.5 M27x3	.875 (23.0)	.50 (12.7)

Inches (mm)

Industrial Shock Absorbers

**M**



For inventory, lead time, and kit lookup, visit [www.pdnplu.com](http://www.pdnplu.com)

M19

**Parker Hannifin Corporation**  
Pneumatic Division  
Richland, Michigan  
[www.parker.com/pneumatics](http://www.parker.com/pneumatics)

**SC<sup>2</sup> Miniature Series SC 190 to SC 925 - Soft Contact & Self-Compensating**

**SC<sup>2</sup> Series Miniature Shock Absorbers**

provide dual performance benefits. They offer **soft contact deceleration** where initial impact reaction forces are very low, with the advantages of **self-compensation** to react to changing energy conditions, without adjustment. They have long stroke lengths, **SC<sup>2</sup> 925 with 1.58 inch (40 mm) superstroke**, to provide smooth deceleration and low reaction forces.

With the addition of the **optional side load adapter** (SC<sup>2</sup> 190M, 300M, and 650M models only), SC<sup>2</sup> Series shock absorbers can handle side loads up to 25°. SC<sup>2</sup> Series shock absorbers are fully interchangeable with the adjustable MA range.

**Applications include:**

Material handling, medium robotics, machine tools, pick and place systems, rodless cylinders and packaging equipment.



**Operating information**

Impact velocity range:	0.5 to 12 ft/sec (0.15 to 3.66 m/sec)
Operating temperature:	32°F to 150°F (0°C to 66°C)

Note: Integral mechanical stop built into front of units.

**Ordering information – Miniature SC<sup>2</sup> series, soft contact and self-compensating**

<b>SC</b>	<b>300</b>	<b>-</b>	<b>1</b>	<b>□</b>
SC <sup>2</sup> series Soft Contact Self Compensating	Model number <b>190</b> <b>300</b> <b>650</b> <b>925</b>	Mounting thread - Standard (UNF) <b>M</b> Metric	Effective weight <b>1</b> Ultra light <b>2</b> Light <b>3</b> Medium <b>4</b> Heavy	Button options - Standard with button <b>-NB</b> No button, short rod <b>-BS</b> No button, standard rod

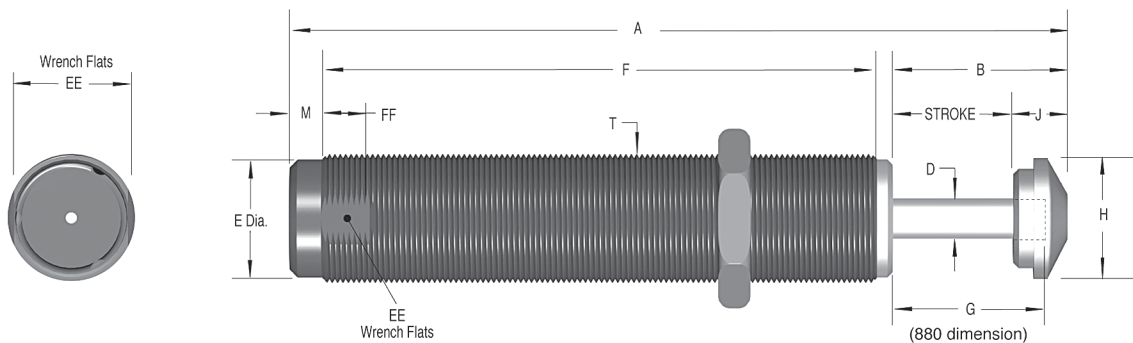
Stroke inches 1 inch = 25.4 mm	E3 max. energy per cycle, inch lbs 1 in lb = .11 Nm	We effective weight lbs, 1 lb = .45 kg	E4 max. energy per hour, in lbs/hour 1 in lb/hour = .11 Nm/hour			Model number
			Self-contained	A/O tank	A/O Re-circulating	
0.63	225	3-15	300,000			<b>SC 190-1</b>
0.63	225	8-40	300,000			<b>SC 190-2</b>
0.63	225	20-100	300,000	N/A	N/A	<b>SC 190-3</b>
0.63	225	50-225	300,000			<b>SC 190-4</b>
0.75	300	3-18	400,000			<b>SC 300-1</b>
0.75	300	10-60	400,000			<b>SC 300-2</b>
0.75	300	30-180	400,000	N/A	N/A	<b>SC 300-3</b>
0.75	300	70-450	400,000			<b>SC 300-4</b>
1.00	650	17-100	600,000			<b>SC 650-1</b>
1.00	650	50-300	600,000			<b>SC 650-2</b>
1.00	650	150-900	600,000	N/A	N/A	<b>SC 650-3</b>
1.00	650	450-2,600	600,000			<b>SC 650-4</b>
1.58	975	30-200	800,000			<b>SC 925-1</b>
1.58	975	90-600	800,000			<b>SC 925-2</b>
1.58	975	250-1,600	800,000	N/A	N/A	<b>SC 925-3</b>
1.58	975	750-4,600	800,000			<b>SC 925-4</b>

**Specifications**

- Mechanical stop – Integral mechanical stop built into front of units.
- Oil type – #5
- Materials – Steel body with black oxide finish. Hardened stainless steel piston rod.
- Technical data applies to standard and metric threaded models.
- Maximum side load depends on application. For additional information contact The Pneumatic Division.
- Lock nut included with each shock absorber.

Model	Return Force lbs (N)	Return Time sec	Shipping Weight lbs (kg)
SC 190-1			
SC 190-2	0.90 - 1.90	0.25	0.18
SC 190-3	(4.00 - 8.95)		(0.08)
SC 190-4			
SC 300-1			
SC 300-2	1.05 - 2.15	0.10	0.25
SC 300-3	(4.67 - 9.56)		(0.11)
SC 300-4			
SC 650-1			
SC 650-2	2.40 - 6.87	0.20	0.67
SC 650-3	(10.67 - 30.55)		(0.31)
SC 650-4			
SC 925-1			
SC 925-2	2.40 - 7.40	0.40	0.87
SC 925-3	(10.67 - 30.55)		(0.39)
SC 925-4			

**SC<sup>2</sup> Series SC 190 to SC 925**  
**Soft Contact and Self-Compensating**



Model	Stroke	A	B	D	E	F	G	H	J	M	T	EE	FF
SC 190	.63	4.50	1.06	.16	.46	3.00	.88	.47	.43	.28	9/16-18 UNF	1/2	.50
SC 190M	(16.0)	(114.3)	(26.9)	(4.1)	(11.7)	(76.2)	(22.4)	(11.9)	(11.0)	(7.1)	M14x1.5	(12.0)	(12.7)
SC 300	.75	4.62	1.18	.19	.66	3.09	1.00	.66	.43	.28	3/4-16 UNF	11/16	.50
SC 300M	(19.1)	(117.5)	(30.0)	(4.8)	(16.8)	(78.5)	(25.4)	(16.8)	(11.0)	(7.1)	M20x1.5	(18.0)	(12.7)
SC 650	1.00	5.62	1.43	.25	.87	3.83	1.25	.90	.43	.28	1-12 UNF	7/8	.50
SC 650M	(25.4)	(142.6)	(36.3)	(6.3)	(22.1)	(97.3)	(31.8)	(22.9)	(11.0)	(7.1)	M25x1.5	(23.0)	(12.7)
SC 925	1.58	7.44	2.01	.25	.87	5.1	1.82	.90	.43	.28	1-12 UNF	7/8	.50
SC 925M	(40.0)	(189.1)	(51.1)	(6.3)	(22.1)	(129.5)	(46.4)	(22.9)	(11.0)	(7.1)	M25x1.5	(23.0)	(12.7)

Inches (mm)

Industrial Shock Absorbers

**M**



For inventory, lead time, and kit lookup, visit [www.pdnplu.com](http://www.pdnplu.com)

M21

**Parker Hannifin Corporation**  
Pneumatic Division  
Richland, Michigan  
[www.parker.com/pneumatics](http://www.parker.com/pneumatics)

**SC<sup>2</sup> Heavyweight Series SC 300 to SC 650 - Soft Contact & Self-Compensating**

SC<sup>2</sup> 300 and SC<sup>2</sup> 650 Heavyweight Series Shock Absorbers deliver up to 950% of the effective weight capacity and 280% of the energy absorption capability of standard models. These durable units are ideal for decelerating heavy weights moving at low velocities. The Heavyweight Series design combines the piston and the inner tube into a single component, the piston tube. It acts as both the pressure creating and pressure controlling device.

SC<sup>2</sup> 300 and SC<sup>2</sup> 650 Heavyweight II Series Shock Absorbers offer effective weight ranges and dramatic increases in energy absorption capability, for handling a wider range of applications.

These revolutionary shock absorbers provide dual performance benefits. They offer **soft contact** deceleration where initial impact reaction forces are very low with the advantages of **self-compensation** to cope with changing input energy conditions without adjustment.

**Applications include:**

Rotary actuators, rodless cylinders, conveyors, pick and place operations, slides as well as operations turning heavy weights at slow speeds.



**Operating information**

Impact velocity range:	0.3 to 12 ft/sec (0.9 to 3.66 m/sec)
Operating temperature:	32°F to 150°F (0°C to 66°C)

**Note: Integral mechanical stop built into front of units.**

**Ordering information – SC<sup>2</sup> series, soft contact and self compensating**

<b>SC</b>	<b>300</b>	<b>-</b>	<b>5</b>	<b> </b>
<b>SC<sup>2</sup> series</b> Soft Contact Self Compensating	<b>Model number</b> 300 650	<b>Mounting thread</b> - Standard (UNF) M Metric	<b>Effective weight</b> 5 Heavy 6 Heavy plus 7 Heavy duty 8 Extra heavy 9 Ultra heavy	<b>Button options</b> Standard with button -NB No button, short rod -880 No button, standard rod

Stroke inches 1 inch = 25.4 mm	E3 max. energy per cycle, inch lbs 1 in lb = .11 Nm	We effective weight lbs, 1 lb = .45 kg	E4 max. energy per hour, in lbs/hour 1 in lb/hour = .11 Nm/hour			Model number
			Self-contained	A/O tank	A/O Re-circulating	
0.59	650	25-100	400,000			SC 300-5
0.59	650	75-300	400,000			SC 300-6
0.59	650	200-400	400,000	N/A	N/A	SC 300-7
0.59	620	300-1,500	400,000			SC 300-8
0.59	620	700-4,300	400,000			SC 300-9
0.91	1,860	50-250	600,000			SC 650-5
0.91	1,860	200-800	600,000			SC 650-6
0.91	1,860	700-2,400	600,000	N/A	N/A	SC 650-7
0.91	1,860	1,700-5,800	600,000			SC 650-8
0.91	1,860	4,000-14,000	600,000			SC 650-9

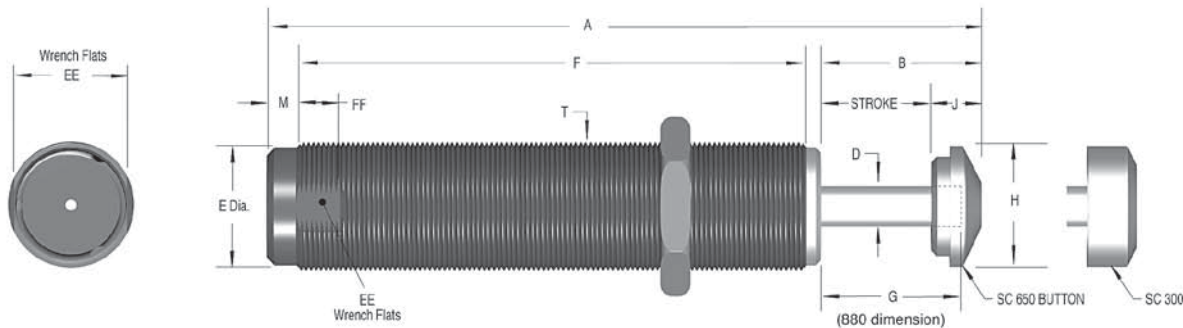


**Specifications**

- Mechanical stop – Integral mechanical stop built into front of units.
- Oil type – #5
- Materials –  
Steel body - with black oxide finish.  
Piston rod - hardened stainless steel
- Technical data applies to standard and metric threaded models.
- Maximum side load depends on application.  
For additional information contact The Pneumatic Division.
- Lock nut included with each shock absorber.

Model	Return Force lbs (N)	Return Time sec	Shipping Weight lbs (kg)
SC 300-5	1.70 - 4.00	0.20	0.33 (0.15)
SC 300-6	(7.56 - 17.79)		
SC 300-7			
SC 300-8	1.70 - 4.00	0.20	0.33 (0.15)
SC 300-9	(7.56 - 17.79)		
SC 650-5	2.40 - 7.30	0.30	0.76 (0.34)
SC 650-6	(10.68 - 32.99)		
SC 650-7			
SC 650-8	2.40 - 7.30	0.30	0.76 (0.34)
SC 650-9	(10.68 - 32.47)		

**SC<sup>2</sup> Heavyweight Series SC 300 to SC 650**  
**Soft Contact and Self-Compensating**



Model	Stroke	A	B	D	E	F	G	H	J	M	T	EE	FF
SC 300-5													
SC 300-6													
SC 300-7													
SC 300-8													
SC 300-9	.59	4.15	1.02	.25	.66	2.78	.84	.67	.43	.28	3/4-16 UNF	11/16	.50
SC 300M-5	(15.0)	(105.4)	(25.9)	(6.4)	(16.8)	(70.6)	(21.3)	(17.0)	(11.0)	(7.1)	M20x1.5	(17.5)	(12.7)
SC 300M-6													
SC 300M-7													
SC 300M-8													
SC 300M-9													
SC 650-5													
SC 650-6													
SC 650-7													
SC 650-8													
SC 650-9	.91	5.51	1.33	.38	.87	3.83	1.16	.88	.43	.28	1-12 UNF	7/8	.50
SC 650M-5	(23.1)	(140.0)	(33.8)	(9.6)	(22.1)	(97.3)	(29.5)	(22.4)	(11.0)	(7.1)	M25x1.5	(22.2)	(12.7)
SC 650M-6													
SC 650M-7													
SC 650M-8													
SC 650M-9													

Inches (mm)

Industrial Shock Absorbers

**M**



For inventory, lead time, and kit lookup, visit [www.pdnplu.com](http://www.pdnplu.com)

M23

**Parker Hannifin Corporation**  
Pneumatic Division  
Richland, Michigan  
[www.parker.com/pneumatics](http://www.parker.com/pneumatics)

**Miniature Shock Absorbers MA 35 to MA 900 - Adjustable**

MA Series miniature shock absorbers offer a compact design with true linear deceleration, and are adjustable over a wide range of conditions. If your preference is a fully adjustable shock absorber rather than a self-compensating model on your application, then the MA Series provides a directly interchangeable alternative.

These adjustable models feature long stroke lengths, **MA 900 with 1.58 inch (40 mm) superstroke**, to provide smooth deceleration and low reaction forces. The MA 150 incorporates the proven rolling diaphragm seal (used on the MC 150 to MC 600 range) and shares all the advantages of that technology.

**Applications include:**

Material handling, medium robotics, pick and place systems, machine tool and packaging equipment.



**Operating information**

Impact velocity range:

MA35	3.3 ft/sec (1.0 m/sec)
MA150, 225, 600, 900	0.5 to 12 ft/sec (0.15 to 3.66 m/sec)

Operating temperature: 32°F to 150°F (0°C to 66°C)

**Ordering information – MA series, adjustable**

<b>MA</b>	<b>225</b>	<b>-</b>	<b>□</b>
MA series MA – Miniature Adjustable	Model number 35 150 225 600 900	Mounting thread - Standard (UNF) M Metric ME Fine metric (MA 150 Only)	Button options <b>MA35</b> Standard with button -NB No button, short rod <b>MA150</b> Standard, no button -B Nylon button -BS Steel button <b>MA 225-900</b> Standard steel button -NB No button, short rod -880 No button, standard rod

Stroke inches 1 inch = 25.4 mm	E3 max energy per cycle, inch lbs 1 in lb = .11 Nm	We effective weight lbs, 1 lb = .45 kg	E4 max energy per hour, in lbs/hour 1 in lb/hour = .11 Nm/hour			Model number
			Self-contained	A/O tank	A/O Re-circulating	
0.40	35	13-125	53,000			<b>MA 35</b> <b>MA 150</b> <b>MA 225</b> <b>MA 600</b>
0.50	150	2-200	300,000			
0.75	225	5-500	400,000	N/A	N/A	
1.00	600	20-3,000	600,000			
1.58	900	30-4,500	800,000	1,100,000 1,200,000	1,500,000 1,600,000	<b>MA 900</b>

## Miniature Shock Absorbers

### Specifications

- Mechanical Stop
- **MA 35** – Integral
- **MA 150** – Must be provided 0.02 to 0.04 inch (0.5 to 1 mm) before end of each stroke.
- **MA 225, 600, 900** – Integral mechanical stop built into front of units.
- Oil type –
  - MA 35 - #5
  - MA 150 - Silicone
  - MA 225, 600, 900 - ATF
- Materials –
  - Steel body - with black oxide finish.
  - Piston rod - hardened stainless steel
- Adjustment –
  - On models MA 35 up to MA 150: by turning the adjustment screw at rear.
  - On the larger sizes: by turning the adjustment knob against the scale marked 0 to 9.
  - After installation, cycle the machine a few times and turn the adjustment knob until optimum deceleration is achieved (i.e. smooth deceleration throughout stroke).
- Hard impact at start of stroke-turn adjuster toward 9.
- Hard set-down at end of stroke-turn adjuster toward 0.

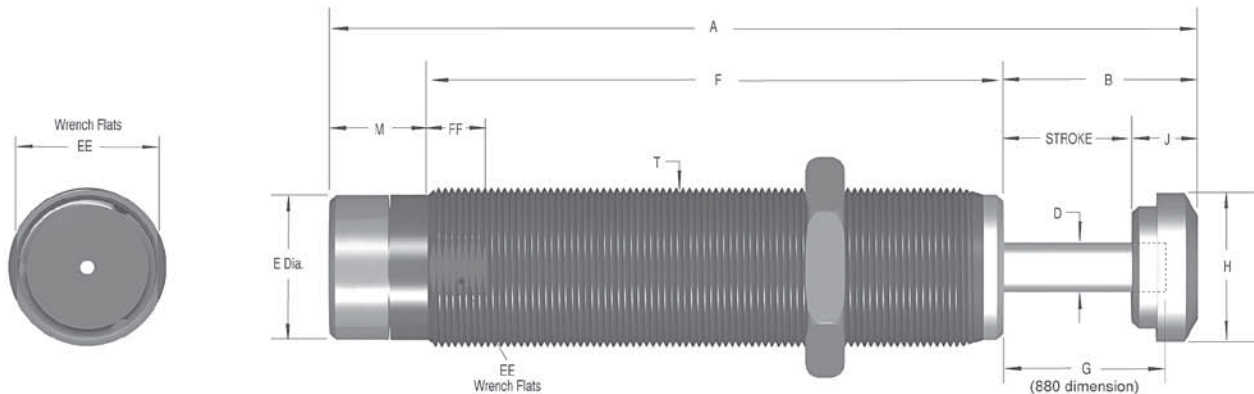
## Industrial Shock Absorbers MA 35 to MA 900 Series, Adjustable

- Technical data applies to standard and metric threaded models.
- Maximum side load depends on application. For additional information contact The Pneumatic Division.
- Lock nut included with each shock absorber.
- MA 35 and MA 150 models can be utilized as velocity controls.

**Note:** MA 150 models may be mounted into pressure chambers of pneumatic actuators.

Model	Return Force lbs (N)	Return Time sec	Shipping Weight lbs (kg)
<b>MA 35</b>	1.20 - 2.60 (5.33 - 11.56)	.17	.10 (0.04)
<b>MA 150</b>	0.70 - 1.20 (3.12 - 5.34)	.40	.12 (0.05)
<b>MA 225</b>	1.05 - 2.15 (4.67 - 9.56)	.10	.28 (0.13)
<b>MA 600</b>	2.40 - 6.87 (10.67 - 30.56)	.20	.67 (0.30)
<b>MA 900</b>	2.40 - 7.40 (10.67 - 32.92)	.40	.87 (0.39)

### Miniature Shock Absorbers MA 35 to MA 900 Adjustable



Model	Stroke	A	B	D	E	F	G	H	J	M	T	EE	FF
<b>MA 35</b>	.40	3.31	.72	.13	.42	2.41	N/A	.30	.32	.18	1/2-20 UNF	N/A	N/A
<b>MA 35M</b>	(10.1)	(84.1)	(18.3)	(3.3)	(10.6)	(61.2)		(7.6)	(8.0)	(4.6)	M12x1		
<b>MA 150</b>	.49	3.64	.92	.19	.46	2.44	.69	.47	.43	.28	9/16 - 18 UNF	.49	.50
<b>MA 150M</b>	(12.4)	(92.5)	(23.4)	(4.8)	(11.6)	(62.0)	(17.5)	(11.9)	(11.0)	(7.1)	M14x1.5	(12.7)	(12.7)
<b>MA 150ME</b>											M14x1		
<b>MA 225</b>	.75	4.67	1.18	.19	.66	2.94	1.00	.66	.43	.55	3/4-16 UNF	11/16	.50
<b>MA 225M</b>	(19.1)	(118.6)	(30.0)	(4.8)	(16.8)	(74.7)	(25.3)	(16.8)	(11.0)	(14.0)	M20x1.5	(18.0)	(12.7)
<b>MA 600</b>	1.00	5.62	1.43	.25	.88	3.54	1.25	.90	.43	.65	1-12 UNF	7/8	.50
<b>MA 600M</b>	(25.4)	(142.6)	(36.3)	(6.3)	(22.4)	(90.0)	(31.8)	(22.9)	(11.0)	(16.5)	M25x1.5	(23.0)	(12.7)
<b>MA 900</b>	1.58	7.44	2.01	.25	.88	4.78	1.85	.90	.43	.65	1-12 UNF	7/8	.50
<b>MA 900M</b>	(40.0)	(189.0)	(51.1)	(6.3)	(22.4)	(121.4)	(46.4)	(22.9)	(11.0)	(16.5)	M25x1.5	(23.0)	(12.7)

Inches (mm)



For inventory, lead time, and kit lookup, visit [www.pdnplu.com](http://www.pdnplu.com)

M25

**Parker Hannifin Corporation**  
Pneumatic Division  
Richland, Michigan  
[www.parker.com/pneumatics](http://www.parker.com/pneumatics)

**Magnum Series MC 33 to MC 64 - Self-Compensating**

Parker presents the ultimate in industrial shock absorber design...the **Magnum Series**. These versatile performers offer you the capability to mount shock absorbers that contain the highest energy capacity ratings in the industry. **Up to 150% of the energy per cycle** of previous models in the same package size, means increased safety factors in a wider range of applications.

**Up to 390% of the effective weight capacity** of previous models, may allow a smaller, lower priced shock absorber to be mounted, to meet your application requirements.

All Magnum Series shock absorbers are **fully threaded** for ease of installation. **Incorporation of high strength materials** along with an **integral stop collar** translates to extended shock absorber life and cost savings for you.

**Applications include:**

Automotive manufacturing and production equipment, large robotics, heavy conveyors, packaging and glass bottling equipment, rotary actuators, theme park rides, and lumber industry equipment.



**Operating information**

Impact velocity range:	
MC Models:	0.5 to 16.5 ft/sec (0.15 to 5 m/sec)
Operating temperature:	
	10°F to 150°F (-12°C to 66°C)

**Ordering information – MC series, self compensating**

MC		3325			-		1		C	
<b>Return method and accumulator style</b>		<b>Model number</b>			<b>Mounting thread</b>		<b>Effective weight</b>		<b>Mounting options</b>	
MC	Self-contained spring return, internal accumulator	3325	4525	6450	-	Standard (UNF)	-1	Light range		Standard mount
MCA	Air return, external accumulator	3350	4550	64100	M	Metric	-2	Medium range		Flanged stop collar
MCS	Spring return, external accumulator	3625	4575	64150			-3	Heavy range		Rectangular flange*
MCN	Self return (clevis), internal accumulator	3650					-4	Heavier range		Square flange*
									-C	Clevis mount**
									-S	Side-foot mount**
									-P	Side port
									-Z	Within air cylinder

\* Welded versions available upon request.  
 \*\* Not available on MC 3625 and 3650 models.

Industrial Shock Absorbers

M



For inventory, lead times, and kit lookup, visit [www.pdnplu.com](http://www.pdnplu.com)

Stroke inches 1 inch = 25.4 mm	E3 max. energy per cycle, inch lbs 1 in lb = .11 Nm	We effective weight lbs, 1 lb = .45 kg	E4 max. energy per hour, in lbs/hour 1 in lb/hour = .11 Nm/hour			Model number
			Self-contained	A/O tank	A/O Re-circulating	
0.91	1,350	20-80	670,000	1,100,000	1,500,000	MC 3325-1
		68-272				MC 3325-2
		230-920				MC 3325-3
		780-3,120				MC 3325-4
1.91	2,700	40-160	760,000	1,200,000	1,600,000	MC 3350-1
		136-544				MC 3350-2
		460-1,840				MC 3350-3
		1,560-6,240				MC 3350-4
0.91	1,350	20-80	670,000	1,100,000	1,500,000	MC 3625-1
		68-272				MC 3625-2
		230-920				MC 3625-3
		780-3,120				MC 3625-4
1.91	2,700	40-160	760,000	1,200,000	1,600,000	MC 3650-1
		136-544				MC 3650-2
		460-1,840				MC 3650-3
		1,560-6,240				MC 3650-4
0.91	3,000	50-200	950,000	1,400,000	1,700,000	MC 4525-1
		170-680				MC 4525-2
		575-2,300				MC 4525-3
		1,950-7,800				MC 4525-4
1.91	6,000	100-400	1,000,000	1,700,000	2,200,000	MC 4550-1
		340-1,360				MC 4550-2
		1,150-4,600				MC 4550-3
		3,900-15,600				MC 4550-4
2.91	9,000	150-600	1,300,000	2,000,000	2,500,000	MC 4575-1
		510-2,040				MC 4575-2
		1,730-6,920				MC 4575-3
		5,850-23,400				MC 4575-4
1.91	15,000	300-1,200	1,300,000	2,600,000	3,400,000	MC 6450-1
		1,020-4,080				MC 6450-2
		3,460-13,840				MC 6450-3
		11,700-46,800				MC 6450-4
3.91	30,000	600-2,400	1,700,000	3,400,000	4,400,000	MC 64100-1
		2,040-8,160				MC 64100-2
		6,920-27,680				MC 64100-3
		23,400-93,600				MC 64100-4
5.91	45,000	900-3,600	2,200,000	4,400,000	5,700,000	MC 64150-1
		3,060-12,240				MC 64150-2
		10,380-41,520				MC 64150-3
		35,100-140,400				MC 64150-4

**Specifications**

- Oil type – ATF
- Materials –
  - Steel body - with black oxide finish
  - Piston rod - high tensile steel, hardened & chrome plated
  - Rod end button - hardened steel with black oxide finish
  - Return spring - zinc plated
 For optimum heat dissipation, do not paint shock absorber.
- Technical data applies to standard and metric threaded models.
- Lock nut included with each shock absorber.

Model	Return Force lbs (N)	Return Time sec	Shipping Weight lbs (kg)
MC 3325	10.3-19.8 (46-88)	0.03	1.00 (0.45)
MC 3350	9.9-30.3 (44-135)	0.06	1.20 (0.54)
MC 3625	10.3-19.8 (46-88)	0.03	1.23 (0.56)
MC 3650	9.9-30.3 (44-135)	0.06	1.51 (0.68)
MC 4525	15.1-22.8 (67-101)	0.03	2.5 (1.13)
MC 4550	15.1-32.2 (67-143)	0.08	3.0 (1.36)
MC 4575	11.7-40.3 (52-179)	0.11	3.5 (1.59)
MC 6450	20.1-34.9 (89-155)	0.12	6.4 (2.90)
MC 64100	23.5-61 (104-271)	0.34	8.15 (3.70)
MC 64150	16.9-82.2 (75-366)	0.48	11.25 (5.10)



For inventory, lead time, and kit lookup, visit [www.pdnplu.com](http://www.pdnplu.com)

M27

**Parker Hannifin Corporation**  
 Pneumatic Division  
 Richland, Michigan  
[www.parker.com/pneumatics](http://www.parker.com/pneumatics)

**Features**

**Magnum Series MA & ML 33 to 64 - Adjustable**

Magnum Series adjustable shock absorbers feature the latest seal technology, a hardened piston ring, pressure chamber and outer body for increased operating life. Additionally, these rugged units offer the unique feature of front or rear adjustment along with a fully threaded outer body for ease of installation.

Magnum Series adjustable shock absorbers are directly interchangeable with obsolete primary series and competitor models.

Along with the self-compensating models, the adjustable range offers unprecedented increases in energy and effective weight capacity.

**Applications include:**

Automotive manufacturing and production equipment, large robotics, heavy conveyors, packaging and glass bottling equipment, rotary actuators, theme park rides, and lumber industry equipment.



**Operating information**

Impact velocity range:

MA Models 0.5 to 16.5 ft/sec (0.15 to 5 m/sec)

ML Models 0.06 to 1.5 ft/sec (0.02 to 0.46 m/sec)

Operating temperature: 10°F to 150°F (-12°C to 66°C)

**Ordering information – MA & ML (low velocity) series, adjustable**

MA		3325					C	
<b>Return method and accumulator style</b>		<b>Model number</b>			<b>Mounting thread</b>		<b>Mounting options</b>	
MA	Self-contained spring return, internal accumulator	3325	4525	6450	-	Standard (UNF)		Standard mount
MAA	Air return, external accumulator	3350	4550	64100	M	Metric		Flanged stop collar
MAS	Spring return, external accumulator	3625	4575	64150				Rectangular flange*
MAN	Self return (clevis), internal accumulator	3650						Square flange*
ML	Self-contained spring return, internal accumulator*						-C	Clevis mount**
MLA	Air return, external accumulator*						-S	Side-foot mount**
MLS	Spring return, external accumulator*						-P	Side port
MLN	Self return (clevis), internal accumulator*						-Z	Within air cylinder

\* Low velocity

\* Welded versions available upon request.  
 \*\* Not available on ML 3625 and 3650 models.

Stroke inches 1 inch = 25.4 mm	E3 max energy per cycle, inch lbs 1 in lb = .11 Nm	We effective weight lbs, 1 lb = .45 kg	E4 max energy per hour, in lbs/hour 1 in lb/hour = .11 Nm/hour			Model number
			Self-contained	A/O tank	A/O Re-circulating	
0.91	1,500	20-3,800	670,000	1,100,000	1,500,000	<b>MA 3325</b>
1.91	3,000	28-5,400	760,000	1,200,000	1,600,000	<b>MA 3350</b>
0.91	1,500	20-3,800	670,000	1,100,000	1,500,000	<b>MA 3625</b>
1.91	3,000	28-5,400	760,000	1,200,000	1,600,000	<b>MA 3650</b>
0.91	3,450	95-22,000	950,000	1,400,000	1,700,000	<b>MA 4525</b>
1.91	6,900	150-32,000	1,000,000	1,700,000	2,200,000	<b>MA 4550</b>
2.91	10,350	155-33,000	1,300,000	2,000,000	2,500,000	<b>MA 4575</b>
1.91	18,000	480-110,000	1,300,000	2,600,000	3,400,000	<b>MA 6450</b>
3.91	36,000	600-115,000	1,700,000	3,400,000	4,400,000	<b>MA 64100</b>
5.91	54,000	730-175,000	2,200,000	4,400,000	5,700,000	<b>MA 64150</b>
0.91	1,500	.05-1.5	670,000	1,100,000	1,500,000	<b>ML 3325</b>
1.91	3,000	.05-1.5	760,000	1,200,000	1,600,000	<b>ML 3350</b>
0.91	1,500	.05-1.5	670,000	1,100,000	1,500,000	<b>ML 3625</b>
1.91	3,000	.05-1.5	760,000	1,200,000	1,600,000	<b>ML 3650</b>
0.91	3,450	.05-1.5	950,000	1,400,000	1,700,000	<b>ML 4525</b>
1.91	6,900	.05-1.5	1,000,000	1,700,000	2,200,000	<b>ML 4550</b>
0.91	9,000	.05-1.5	1,100,000	2,200,000	2,900,000	<b>ML 6425</b>
1.91	18,000	.05-1.5	1,300,000	2,600,000	3,400,000	<b>ML 6450</b>

**Specifications**

- Oil type – ATF
- Materials –
  - Steel body - with black oxide finish
  - Piston rod - high tensile steel, hardened & chrome plated
  - Rod end button - hardened steel with black oxide finish
  - Return spring - zinc plated
 For optimum heat dissipation, do not paint shock absorber.
- Adjustment – After installation of the Magnum Series shock absorber, cycle the machine a number of times. Turn the front stop collar or the rear adjuster against the scale marked 0 to 9 until optimum deceleration is achieved (i.e. smooth deceleration throughout the stroke).
- Hard impact at start of stroke-turn adjuster toward 9.
- Hard set-down at end of stroke-turn adjuster toward 0.
- Technical data applies to standard and metric threaded models.
- The Pneumatic Division recommends that side load not exceed 5°. Maximum side load depends on application. For additional information consult The Pneumatic Division.
- Lock nut included with each shock absorber.

Model	Return Force lbs (N)	Return Time sec	Shipping Weight lbs (kg)
<b>MA 3325</b>	10.3-19.8	0.03	1.0 (0.45)
<b>ML 3325</b>	(46-88)		
<b>MA 3350</b>	9.9-30.3	0.06	1.2 (0.54)
<b>ML 3350</b>	(44-135)		
<b>MA 3625</b>	10.3-19.8	0.03	1.23 (0.56)
<b>ML 3625</b>	(46-88)		
<b>MA 3650</b>	9.9-30.3	0.06	1.51 (0.68)
<b>ML 3650</b>	(44-135)		
<b>MA 4525</b>	15.1-22.8	0.03	2.5 (1.13)
<b>ML 4525</b>	(67-101)		
<b>MA 4550</b>	15.1-32.2	0.08	3.0 (1.36)
<b>ML 4550</b>	(67-143)		
<b>MA 4575</b>	11.7-40.3	0.11	3.5 (1.59)
<b>ML 4575</b>	(52-179)		
<b>ML 6425</b>	26.7-34.9	0.06	5.5 (2.49)
<b>ML 6425</b>	(119-155)		
<b>MA 6450</b>	20.1-34.9	0.12	6.4 (2.90)
<b>ML 6450</b>	(89-155)		
<b>MA 64100</b>	23.5-61	0.34	8.15 (3.70)
<b>ML 64100</b>	(104-271)		
<b>MA 64150</b>	16.9-82.2	0.48	11.25 (5.10)
<b>ML 64150</b>	(75-366)		

**Impact velocity range:**

- MA: 0.5 to 16.5 ft/sec (0.15 to 5 m/sec)
- ML: 0.06 to 1.5 ft/sec (0.02 to 0.46 m/sec)

**Note:** Side load not to exceed 5°. Maximum side load depends on application.



For inventory, lead time, and kit lookup, visit [www.pdnplu.com](http://www.pdnplu.com)

M29

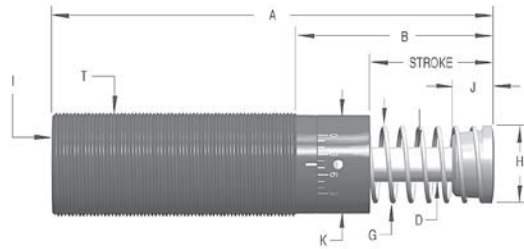
**Parker Hannifin Corporation**  
Pneumatic Division  
Richland, Michigan  
[www.parker.com/pneumatics](http://www.parker.com/pneumatics)

**Magnum Series MC/MA/ML 33, Self-Compensating and Adjustable**

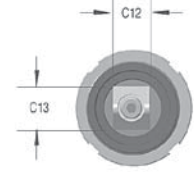
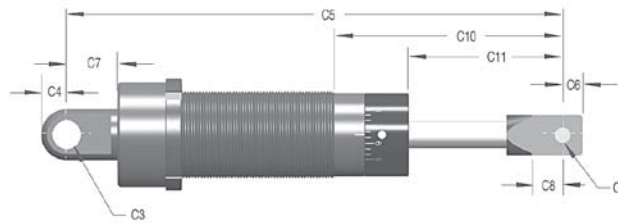
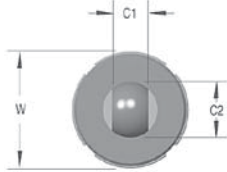
**Primary Mount**



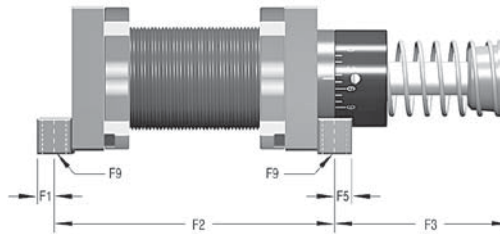
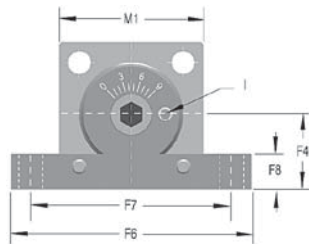
Adjuster (MA and ML only)



**Clevis Mount**



**Side-Foot Mount**



**Magnum Series MC/MA/ML 33 Inches (mm)**

Model	Stroke	A	B	D	G	H	I*	J	K	T	W	C1	C2	C3	C4	C5	C6
3325	0.91 (23.1)	5.44 (138.1)	2.19 (55.6)	0.375 (9.5)	0.99 (25.1)	1.00 (25.4)	1/8 NPT Male	0.75 (19.1)	1.15 (29.2)	1-1/4-12 M33x1.5	1.50 (38.10)	0.50 (12.7)	0.76 (19.3)	.2505 (6.40)	0.32 (8.1)	6.58 (167)	0.25 (6.4)
3350	1.91 (48.5)	7.44 (189)	3.19 (81)	0.375 (9.5)	0.99 (25.1)	1.00 (25.4)	1/8 NPT Male	0.75 (19.1)	1.15 (29.2)	1-1/4-12 M33x1.5	1.56 (39.71)	0.50 (12.7)	0.76 (19.3)	.2505 (6.40)	0.32 (8.1)	8.58 (217.8)	0.25 (6.4)
		C7	C8	C9	C10	C11	C12	C13	F1	F2	F3	F4	F5	F6	F7	F8	F9
3325	0.48 (12.2)	0.50 (12.7)	.2505 (6.4)	2.64 (67.1)	1.36 (34.5)	0.50 (12.7)	0.75 (19.1)	0.25 (6.4)	3.75 (95.3)	1.94 (49.3)	0.87 (22.1)	0.25 (6.4)	2.75 (69.9)	2.37 (60)	0.50 (12.7)	0.23 (5.9)	
3350	0.48 (12.2)	0.50 (12.7)	.2505 (6.4)	3.64 (92.5)	2.36 (60)	0.50 (12.7)	0.75 (19.1)	0.25 (6.4)	4.75 (120.7)	2.94 (74.7)	0.87 (22.1)	0.25 (6.4)	2.75 (69.9)	2.37 (60)	0.50 (12.7)	0.23 (5.9)	

**Magnum Series MC/MA/ML 36 Inches (mm)**

Model	Stroke	A	B	D	G	H	I*	J	K	T	W
3625	0.91 (23.1)	5.44 (138.1)	2.19 (55.6)	0.375 (9.5)	0.99 (25.1)	1.00 (25.4)	1/8 NPT Male	0.75 (19.1)	1.15 (29.2)	1-3/8-12 M36x1.5	1.75 (44.5)
3650	1.91 (48.5)	7.44 (189)	3.19 (81)	0.375 (9.5)	0.99 (25.1)	1.00 (25.4)	1/8 NPT Male	0.75 (19.1)	1.15 (29.2)	1-3/8-12 M36x1.5	1.75 (44.5)

\* For models MAA and MAS 33 the 1/8-27 male fitting is shipped with the shock.

- Notes:**
1. For models MAA, MLA and MCA indicate P for the side port option when ordering clevis mount.
  2. M36 and 1-3/8 thread is optional.
  3. A side port can be adapted to Magnum Series 33 MAA, MLA and MCA models and is a special adder item. A side port adapter ring is molded onto the outer tube and increases the overall diameter by 0.25 inches (6.3 mm) in the area of the ring. The side port centerline is located 0.81 inches (20.7 mm) from the front of the outer tube. Add (-P) to the model ordering code if a side port is desired.
  4. Poly pad available on 33 models only – part no. 250-0011.
  5. Lock nut included with each shock absorber. See page L48 for dimensions.
  6. All dimensions and tolerance values listed in this catalog are nominal and subject to change without prior notice.

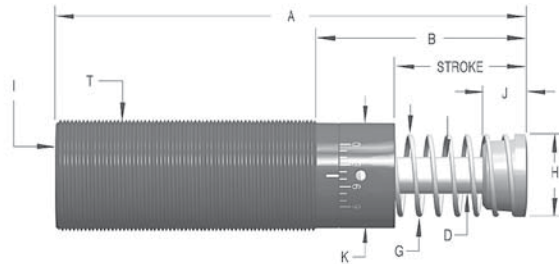


**Magnum Series MC/MA/ML 45, Self-Compensating and Adjustable**

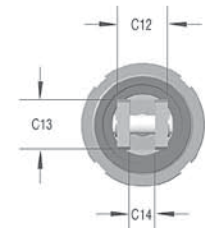
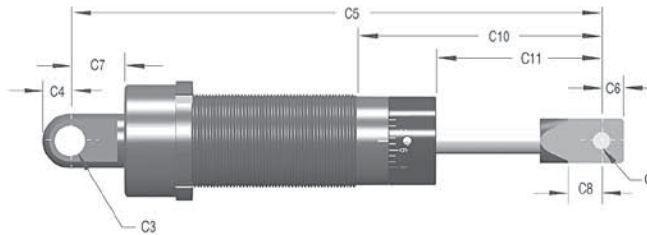
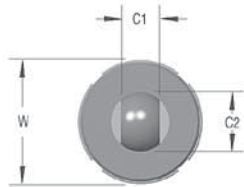
**Primary Mount**



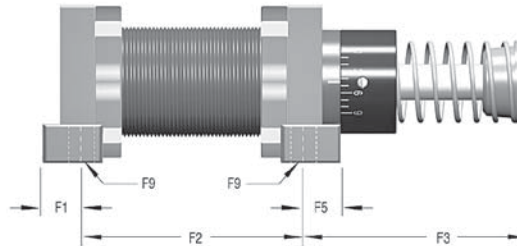
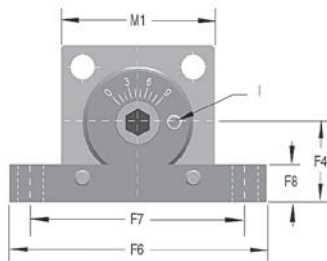
Adjuster (MA and ML only)



**Clevis Mount**



**Side-Foot Mount**



**Magnum Series MC/MA/ML 45 Inches (mm)**

Model	Stroke	A	B	D	G	H	I*	J	K	T	W	C1	C2	C3	C4	C5	C6	
4525	0.91 (23.1)	5.69 (144.5)	1.97 (50)	0.50 (12.7)	1.36 (34.5)	1.38 (34.9)	1/8 NPT	0.87 (22.1)	1.65 (41.9)	1-3/4-12 M45x1.5	2.25 (57.20)	0.75 (19.1)	1.00 (25.4)	.5005 (12.7)	0.50 (12.7)	7.85 (199.4)	0.50 (12.7)	
4550	1.91 (48.5)	7.69 (195.3)	2.97 (75.4)	0.50 (12.7)	1.36 (34.5)	1.38 (34.9)	1/8 NPT	0.87 (22.1)	1.65 (41.9)	1-3/4-12 M45x1.5	2.25 (57.20)	0.75 (19.1)	1.00 (25.4)	.5005 (12.7)	0.50 (12.7)	9.85 (250.2)	0.50 (12.7)	
4575 †	2.91 (73.9)	9.69 (246.1)	3.97 (100.8)	0.50 (12.7)	1.36 (34.5)	1.38 (34.9)	1/8 NPT	0.87 (22.1)	1.65 (41.9)	1-3/4-12 M45x1.5	2.25 (57.20)	0.75 (19.1)	1.00 (25.4)	.5005 (12.7)	0.50 (12.7)	11.85 (301)	0.50 (12.7)	
		C7	C8	C9	C10	C11	C12	C13	C14	F1	F2	F3	F4	F5	F6	F7	F8	F9
4525		1.06 (26.9)	0.69 (17.5)	.3755 (9.6)	2.57 (65.3)	1.51 (38.4)	1.00 (25.4)	1.00 (25.4)	.505 (12.8)	0.50 (12.7)	3.50 (88.9)	1.94 (49.3)	1.16 (29.5)	0.37 (9.5)	3.75 (95.3)	3.00 (76.2)	0.56 (14.2)	0.35 (8.9)
4550		1.06 (26.9)	0.69 (17.5)	.3755 (9.6)	3.57 (90.7)	2.51 (63.8)	1.00 (25.4)	1.00 (25.4)	.505 (12.8)	0.50 (12.7)	4.38 (111.8)	3.06 (77.7)	1.16 (29.5)	0.37 (9.5)	3.75 (95.3)	3.00 (76.2)	0.56 (14.2)	0.35 (8.9)
4575 †		1.06 (26.9)	0.69 (17.5)	.3755 (9.6)	4.57 (116.1)	3.51 (89.2)	1.00 (25.4)	1.00 (25.4)	.505 (12.8)	0.50 (12.7)	5.38 (237.8)	4.06 (103.1)	1.16 (29.5)	0.37 (9.5)	3.75 (95.3)	3.00 (76.2)	0.56 (14.2)	0.35 (8.9)

† Models MC, MA only

\* For models MAA and MAS 45 have pipe plugs.

**Notes:** 1. A side port can be adapted to Magnum Series 45 MAA, MLA and MCA models and is a special adder item. A side port adapter ring is molded onto the outer tube and increases the overall diameter by 0.5 inches (12.7 mm) in the area of the ring. The side port centerline is located 1.04 inches (26.4 mm) from the front of the outer tube. Add (-P) to the model ordering code if a side port is desired.

2. Side load not to exceed 5°. Maximum side load depends on application.

3. Lock nut included with each shock absorber. See page L48 for dimensions.



For inventory, lead time, and kit lookup, visit [www.pdnplu.com](http://www.pdnplu.com)

M31

[www.comosoc.com](http://www.comosoc.com)

**Parker Hannifin Corporation**  
 Pneumatic Division  
 Richland, Michigan  
[www.parker.com/pneumatics](http://www.parker.com/pneumatics)

Industrial Shock Absorbers

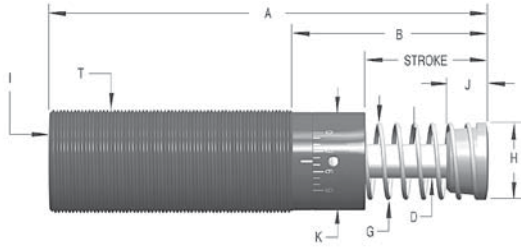
**M**

**Magnum Series MC/MA/ML 64, Self-Compensating and Adjustable**

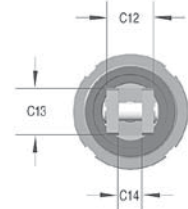
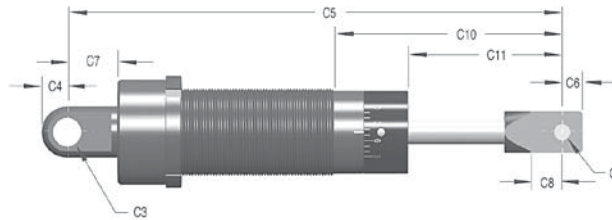
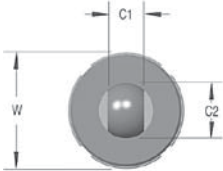
**Primary Mount**



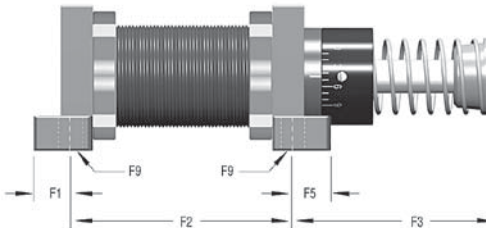
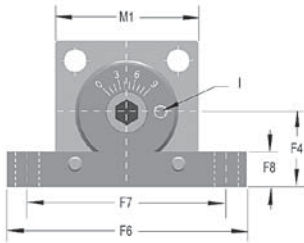
Adjuster (MA and ML only)



**Clevis Mount**



**Side-Foot Mount**



**Magnum Series MC/MA/ML 45 Inches (mm)**

Model	Stroke	A	B	D	G	H	I*	J	K	T	W	C1	C2	C3	C4	C5	C6	
6425 ◊	0.91 (23.1)	6.85 (174)	2.35 (59.7)	0.75 (19.1)	1.86 (47.2)	1.90 (48.3)	1/4 NPT	1.06 (26.9)	2.37 (60.2)	2-1/2-12 M64x2	3.00 (76.20)	1.25 (31.8)	1.50 (38.1)	.7505 (19.1)	0.75 (19.1)	10.12 (257.1)	0.63 (16.0)	
6450	1.91 (48.6)	8.85 (224.8)	3.35 (85.1)	0.75 (19.1)	1.86 (47.2)	1.90 (48.3)	1/4 NPT	1.06 (26.9)	2.37 (60.2)	2-1/2-12 M64x2	3.00 (76.20)	1.25 (31.8)	1.50 (38.1)	.7505 (19.1)	0.75 (19.1)	12.12 (307.9)	0.63 (16.0)	
64100 †	3.91 (99.4)	12.85 (326.4)	5.35 (135.9)	0.75 (19.1)	1.86 (47.2)	1.90 (48.3)	1/4 NPT	1.06 (26.9)	2.37 (60.2)	2-1/2-12 M64x2	3.00 (76.20)	1.25 (31.8)	1.50 (38.1)	.7505 (19.1)	0.75 (19.1)	16.12 (409.5)	0.63 (16.0)	
64150 †	5.91 (150.1)	17.73 (450.4)	8.23 (209)	0.75 (19.1)	2.31 (58.7)	2.38 (60.3)	1/4 NPT	1.25 (31.8)	2.37 (60.2)	2-1/2-12 M64x2	3.00 (76.20)	1.25 (31.8)	1.50 (38.1)	.7505 (19.1)	0.75 (19.1)	20.87 (530.1)	0.63 (16.0)	
64150 ‡	5.91 (150.1)	17.60 (447)	8.10 (205.7)	0.75 (19.1)	-	1.90 (48.3)	1/4 NPT	1.06 (26.9)	2.37 (60.2)	2-1/2-12 M64x2	-	-	-	-	-	-	-	
		C7	C8	C9	C10	C11	C12	C13	C14	F1	F2	F3	F4	F5	F6	F7	F8	F9
6425 ◊		1.29 (32.8)	1.40 (35.6)	.7505 (19.1)	3.75 (95.2)	2.31 (58.7)	1.50 (38.1)	1.25 (31.8)	.625 (15.9)	0.69 (17.5)	4.00 (101.6)	2.56 (65.0)	1.78 (45.2)	0.69 (17.5)	5.62 (142.8)	4.88 (124.0)	0.75 (19.1)	0.42 (10.7)
6450		1.29 (32.8)	1.40 (35.6)	.7505 (19.1)	4.75 (120.7)	3.31 (84.1)	1.50 (38.1)	1.25 (31.8)	.625 (15.9)	0.69 (17.5)	5.00 (127.0)	3.56 (90.4)	1.78 (45.2)	0.69 (17.5)	5.62 (142.8)	4.88 (124.0)	0.75 (19.1)	0.42 (10.7)
64100 †		1.29 (32.8)	1.40 (35.6)	.7505 (19.1)	6.75 (171.5)	5.31 (134.9)	1.50 (38.1)	1.25 (31.8)	.625 (15.9)	0.69 (17.5)	7.00 (177.8)	5.56 (141.2)	1.78 (45.2)	0.69 (17.5)	5.62 (142.8)	4.88 (124.0)	0.75 (19.1)	0.42 (10.7)
64150 †		1.29 (32.8)	1.40 (35.6)	.7505 (19.1)	9.50 (241.3)	8.06 (204.7)	1.50 (38.1)	1.25 (31.8)	.625 (15.9)	0.69 (17.5)	9.00 (228.6)	8.44 (214.4)	1.78 (45.2)	0.69 (17.5)	5.62 (142.8)	4.88 (124.0)	0.75 (19.1)	0.42 (10.7)
64150 ‡		-	-	-	-	-	-	-	.625 (15.9)	0.69 (17.5)	-	8.31 (211.1)	1.78 (45.2)	0.69 (17.5)	5.62 (142.8)	4.88 (124.0)	0.75 (19.1)	0.42 (10.7)

◊ Model ML only.

† Models MC, MA only.

‡ Models MCA, MAA only.

\* For models MAA and MAS 64 have pipe plugs.

- Notes:**
1. A side port can be adapted to Magnum Series 64 MAA, MLA and MCA models and is a special adder item. A side port adapter ring is molded onto the outer tube and increases the overall diameter by 0.5 inches (12.7 mm) in the area of the ring. The side port centerline is located 1.47 inches (37.3 mm) from the front of the outer tube. Add (-P) to the model ordering code if a side port is desired.
  2. MA and MC 64150 models include an integral, non-removable stop block, not a stop collar. Adjustable models can be adjusted from front or rear.
  3. MAA and MCA 64150 models include a stop collar, 0.75 inches (19 mm) longer than the standard 64 model stop collar.
  4. For models MAA, MLA and MCA indicate P for the side port option when ordering clevis mount.
  5. 64150 models do not include a stop collar. Adjustable models can still be adjusted from front or rear.
  6. Side load not to exceed 5°. Maximum side load depends on application.
  7. Lock nut included with each shock absorber. See page L48 for dimensions.

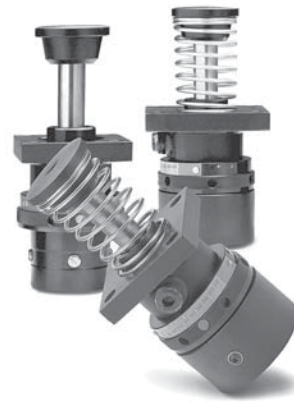
Features

1-1/2" Bore Series - Adjustable

1-1/2" bore series shock absorbers are designed for the toughest environments. These durable adjustable models provide outstanding deceleration over a wide range of effective weight conditions. Large energy capacities stop heavy loads set into motion by high propelling forces, without damage.

Applications include:

Automotive manufacturing and production equipment, large robotics, heavy conveyors, foundries and steel industry equipment.



Operating information

Impact velocity range:	0.5 to 15 ft/sec (0.15 to 4.5 m/sec)
Operating temperature:	10°F to 150°F (-12°C to 66°C)

Ordering information – 1-1/2" bore series, adjustable

<b>A</b>	<b>1-1/2</b>	<b>6-1/2</b>	<b>F</b>																									
<b>Return method and accumulator style</b>	<b>Bore size</b>	<b>Stroke length</b>	<b>Mounting style</b>																									
<table border="1"> <tr><td>A</td><td>Spring return, internal accumulator</td></tr> <tr><td>AA</td><td>Air return, external accumulator</td></tr> <tr><td>SA</td><td>Spring return, external accumulator</td></tr> <tr><td>NA</td><td>Self return (clevis), internal accumulator</td></tr> </table>	A	Spring return, internal accumulator	AA	Air return, external accumulator	SA	Spring return, external accumulator	NA	Self return (clevis), internal accumulator	<table border="1"> <tr><td>1-1/2</td></tr> </table>	1-1/2	<table border="1"> <tr><td>2</td></tr> <tr><td>3-1/2</td></tr> <tr><td>5</td></tr> <tr><td>6-1/2</td></tr> </table>	2	3-1/2	5	6-1/2	<table border="1"> <tr><td>-F</td><td>Front flange</td></tr> <tr><td>-R</td><td>Rear flange</td></tr> <tr><td>-RF</td><td>Front rectangular flange</td></tr> <tr><td>-RR</td><td>Rear rectangular flange</td></tr> <tr><td>-S</td><td>Side foot mount</td></tr> <tr><td>-C</td><td>Clevis mount</td></tr> </table>	-F	Front flange	-R	Rear flange	-RF	Front rectangular flange	-RR	Rear rectangular flange	-S	Side foot mount	-C	Clevis mount
A	Spring return, internal accumulator																											
AA	Air return, external accumulator																											
SA	Spring return, external accumulator																											
NA	Self return (clevis), internal accumulator																											
1-1/2																												
2																												
3-1/2																												
5																												
6-1/2																												
-F	Front flange																											
-R	Rear flange																											
-RF	Front rectangular flange																											
-RR	Rear rectangular flange																											
-S	Side foot mount																											
-C	Clevis mount																											

Stroke inches 1 inch = 25.4 mm	E3 max energy per cycle, inch lbs 1 in lb = .11 Nm	We effective weight lbs, 1 lb = .45 kg	E4 max energy per hour, in lbs/hour 1 in lb/hour = .11 Nm/hour			Model number
			Self-contained	A/O tank	A/O Re-circulating	
2.00	16,000	430-70,000	3,200,000	4,000,000	5,200,000	1-1/2x2
3.50	28,000	480-80,000	5,600,000	7,000,000	9,100,000	1-1/2x3-1/2
5.00	40,000	500-90,000	8,000,000	10,000,000	13,000,000	1-1/2x5
6.50	52,000	680-100,000	10,400,000	13,000,000	17,000,000	1-1/2x6-1/2

Specifications

- Mechanical stop – must be provided .09 inch (2.3 mm) before end of stroke.
- Oil type – American 46
- Materials –
  - Steel body - with black oxide finish
  - Piston rod - high tensile steel, hardened & chrome plated
  - Return spring - zinc plated
- Adjustment – after installation of the shock absorber, cycle the machine a number of times. Turn the adjustment ring against the scale marked 0 to 9, until optimum deceleration is achieved (i.e. smooth deceleration throughout the stroke).

- Hard impact at the start of stroke-turn adjuster toward 9
- Hard set-down at the end of stroke-turn adjuster toward 0
- Poly pad – Optional

Model	Return Force lbs (N)	Return Time sec	Shipping Weight lbs (kg)
1-1/2 x 2	34.9 - 47.6 (155 - 210)	.10	16.4 (7.44)
1-1/2 x 3-1/2	25.4 - 47.6 (113-210)	.25	19.4 (8.80)
1-1/2 x 5	20.7 - 52.5 (92 - 230)	.40	22.7 (10.30)
1-1/2 x 6-1/2	20.7 - 97.4 (92 - 430)	.40	25.0 (11.34)



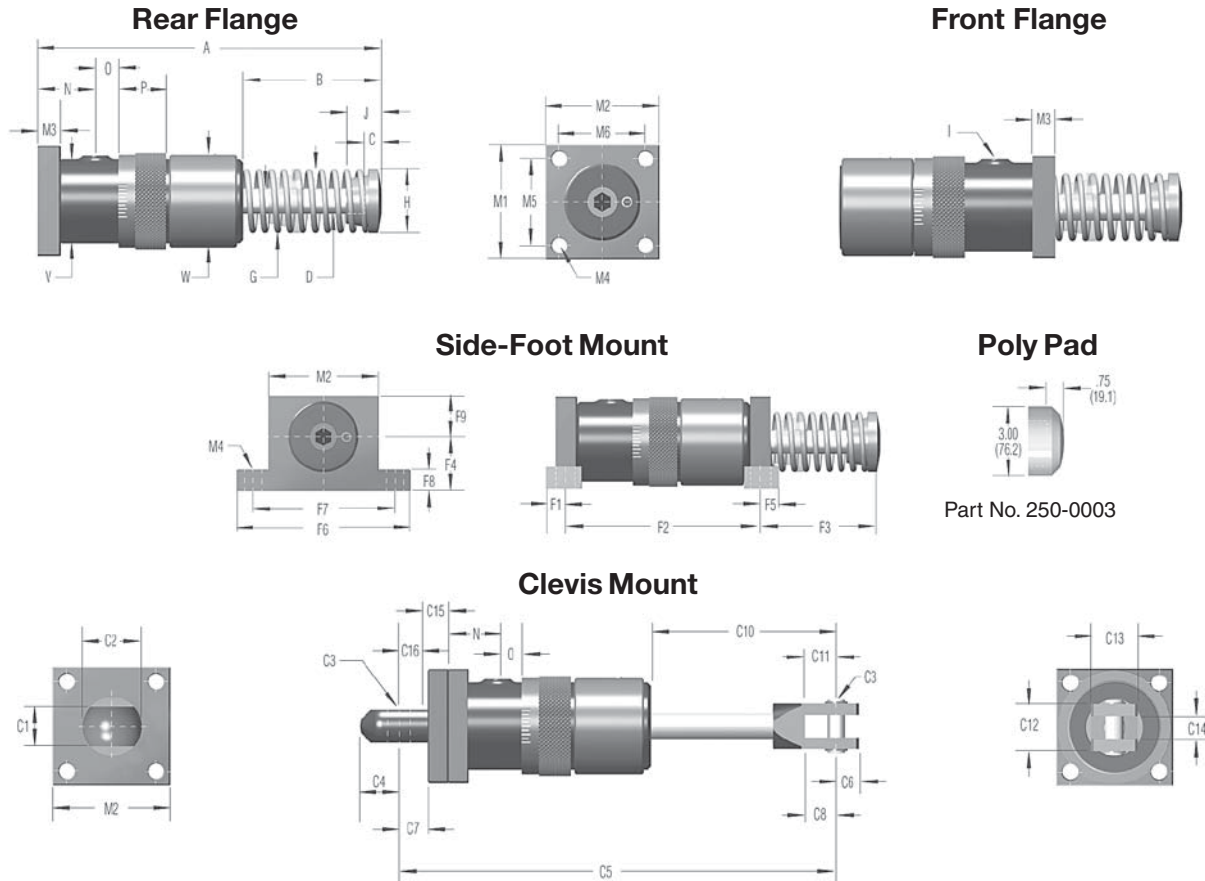
For inventory, lead time, and kit lookup, visit [www.pdnplu.com](http://www.pdnplu.com)

M33

Parker Hannifin Corporation  
Pneumatic Division  
Richland, Michigan  
[www.parker.com/pneumatics](http://www.parker.com/pneumatics)

Dimensional Data

1-1/2" Bore Series, Adjustable



1-1/2" Bore Series Dimensions Inches (mm)

Model	Stroke	A	B	CC	D	G	H	I	J	N	O	P	V	W	C1	C2	
1-1/2 x 2	2.00 (50.8)	9.69 (246.1)	4.13 (104.8)	0.81 (20.6)	1.00 (25.4)	2.69 (68.3)	2.75 (69.9)	1/2 NPT	1.38 (35.1)	1.38 (35.0)	0.28 (7.1)	1.25 (31.8)	3.00 (76.2)	4.00 (101.6)	1.25 (31.8)	1.50 (38.1)	
1-1/2 x 3-1/2	3.50 (88.9)	12.69 (322.3)	5.63 (142.9)	0.81 (20.6)	1.00 (25.4)	2.69 (68.3)	2.75 (69.9)	1/2 NPT	1.38 (35.1)	2.00 (50.8)	0.28 (7.1)	1.25 (31.8)	3.00 (76.2)	4.00 (101.6)	1.25 (31.8)	1.50 (38.1)	
1-1/2 x 5	5.00 (127.0)	15.69 (398.5)	7.13 (181.0)	0.81 (20.6)	1.00 (25.4)	2.69 (68.3)	2.75 (69.9)	1/2 NPT	1.38 (35.1)	2.00 (50.8)	1.03 (26.2)	1.25 (31.8)	3.00 (76.2)	4.00 (101.6)	1.25 (31.8)	1.50 (38.1)	
1-1/2 x 6-1/2	6.50 (165.1)	19.44 (493.7)	9.38 (238.1)	0.81 (20.6)	1.00 (25.4)	2.69 (68.3)	2.75 (69.9)	1/2 NPT	1.38 (35.1)	2.00 (50.8)	1.78 (45.2)	1.25 (31.8)	3.00 (76.2)	4.00 (101.6)	1.25 (31.8)	1.50 (38.1)	
		<b>C3</b>	<b>C4</b>	<b>C5</b>	<b>C6</b>	<b>C7</b>	<b>C8</b>	<b>C10</b>	<b>C11</b>	<b>C12</b>	<b>C13</b>	<b>C14</b>	<b>C15</b>	<b>C16</b>	<b>F1</b>	<b>F2</b>	<b>F3</b>
1-1/2 x 2	0.7525 (19.11)	0.75 (19.1)	12.94 (328.6)	0.63 (16.0)	1.25 (31.8)	1.41 (35.7)	5.41 (137.3)	1.40 (35.6)	1.50 (38.1)	1.25 (31.8)	5/8	0.94 (23.9)	1.06 (27.0)	0.63 (15.9)	† 5.18 (131.6)	† 4.31 (109.5)	
1-1/2 x 3-1/2	0.7525 (19.11)	0.75 (19.1)	15.97 (405.6)	0.63 (16.0)	1.25 (31.8)	1.41 (35.7)	6.91 (175.4)	1.40 (35.6)	1.50 (38.1)	1.25 (31.8)	5/8	0.94 (23.9)	1.06 (27.0)	0.63 (15.9)	6.69 (169.9)	5.81 (147.6)	
1-1/2 x 5	0.7525 (19.11)	0.75 (19.1)	18.97 (481.8)	0.63 (16.0)	1.25 (31.8)	1.41 (35.7)	8.41 (213.5)	1.40 (35.6)	1.50 (38.1)	1.25 (31.8)	5/8	0.94 (23.9)	1.06 (27.0)	0.63 (15.9)	8.19 (208.0)	7.31 (185.7)	
1-1/2 x 6-1/2	0.7525 (19.11)	0.75 (19.1)	22.72 (577.1)	0.63 (16.0)	1.25 (31.8)	1.41 (35.7)	10.66 (270.7)	1.40 (35.6)	1.50 (38.1)	1.25 (31.8)	5/8	0.94 (23.9)	1.06 (27.0)	0.63 (15.9)	9.69 (246.1)	9.56 (242.8)	
		<b>F4</b>	<b>F5</b>	<b>F6</b>	<b>F7</b>	<b>F8</b>	<b>F9</b>	<b>M1</b>	<b>M2</b>	<b>M3</b>	<b>M4</b>	<b>M5</b>	<b>M6</b>				
1-1/2 x 2	2.00 (50.8)	0.63 (16.0)	6.50 (165.1)	5.50 (139.7)	0.75 (19.1)	2.03 (51.6)	4.00 (101.6)	4.00 (101.6)	0.75 (19.0)	0.53 (13.5)	3.00 (76.2)	3.00 (76.2)					
1-1/2 x 3-1/2	2.00 (50.8)	0.63 (16.0)	6.50 (165.1)	5.50 (139.7)	0.75 (19.1)	2.03 (51.6)	4.00 (101.6)	4.00 (101.6)	0.75 (19.0)	0.53 (13.5)	3.00 (76.2)	3.00 (76.2)					
1-1/2 x 5	2.00 (50.8)	0.63 (16.0)	6.50 (165.1)	5.50 (139.7)	0.75 (19.1)	2.03 (51.6)	∅	4.00 (101.6)	0.75 (19.0)	0.53 (13.5)	∅	3.00 (76.2)					
1-1/2 x 6-1/2	2.00 (50.8)	0.63 (16.0)	6.50 (165.1)	5.50 (139.7)	0.75 (19.1)	2.03 (51.6)	5.00 (127.0)	4.00 (101.6)	0.75 (19.0)	0.53 (13.5)	4.00 (101.6)	3.00 (76.2)					

∅ Rectangular flange dimension

† Note: 1-1/2 x 2 shock absorbers available with side-foot mount in AA and SA models only.

Features

Heavy Industrial Shock Absorbers CA 2 to CA 3 - Self-Compensating

CA 2" & CA 3" Bore Series of self-compensating shock absorbers are designed for extremely heavy duty applications and provide smooth deceleration under changing conditions. High energy capacities combined with wide effective weight ranges qualify these units to perform in the most demanding environments.

The new CA 2 offers up to 170% of the energy per cycle capacity of former models. The rugged new CA 3 offers up to 125% of the energy capacity of former models. Replacing existing shock absorbers with the new CA Series is easy-just provide us the type and adjustment setting of your existing units and we will, do the rest. These dependable units are available self-contained or for use with an external air/oil tank.



Applications include:

Foundry, steel, marine, lumber and other heavy equipment industries.

Operating information

Impact velocity range:	1 to 16.5 ft/sec (0.30 to 5 m/sec)
Operating temperature:	10°F to 150°F (-12°C to 66°C)

Ordering information – CA 2 & CA 3 series, self-compensating

<b>CA</b>	<b>2</b>	x	<b>8</b>	<b>R</b>	-	<b>3</b>
<b>Return method and accumulator style</b>		<b>Bore size</b>	<b>Stroke length</b>	<b>Mounting style</b>		<b>Effective weight</b>
<b>CA</b>	Spring return, internal accumulator	<b>2</b>	2	<b>-F</b>	Front flange	<b>-1</b> Light
<b>CAA</b>	Air return, external accumulator	<b>3</b>	4	<b>-R</b>	Rear flange	<b>-2</b> Medium light
<b>CSA</b>	Spring return, external accumulator		5	<b>-RF</b>	Front rectangular flange	<b>-3</b> Medium heavy
<b>CNA</b>	Self return (clevis), internal accumulator		6	<b>-RR</b>	Rear rectangular flange	<b>-4</b> Heavy
			8	<b>-S</b>	Side foot mount	
			10	<b>-C</b>	Clevis mount	
			12			



Stroke inches 1 inch = 25.4 mm	E3 max energy per cycle, inch lbs 1 in lb = .11 Nm	We effective weight lbs, 1 lb = .45 kg	E4 max energy per hour, in lbs/hour 1 in lb/hour = .11 Nm/hour			Model number
			Self-contained	A/O tank	A/O Re-circulating	
2.00	32,000	1,600-4,800 4,000-12,000 10,000-30,000 25,000-75,000	9,600,000	12,000,000	15,600,000	CA 2x2-1 CA 2x2-2 CA 2x2-3 CA 2x2-4
4.00	64,000	3,200-9,600 8,000-24,000 20,000-60,000 50,000-150,000	12,000,000	15,000,000	19,500,000	CA 2x4-1 CA 2x4-2 CA 2x4-3 CA 2x4-4
6.00	96,000	4,800-14,400 12,000-36,000 30,000-90,000 75,000-225,000	14,400,000	18,000,000	23,500,000	CA 2x6-1 CA 2x6-2 CA 2x6-3 CA 2x6-4
8.00	128,000	6,400-19,200 16,000-48,000 40,000-120,000 100,000-300,000	16,800,000	21,000,000	27,000,000	CA 2x8-1 CA 2x8-2 CA 2x8-3 CA 2x8-4
10.00	160,000	8,000-24,000 20,000-60,000 50,000-150,000 125,000-375,000	19,200,000	24,000,000	31,000,000	CA 2x10-1 CA 2x10-2 CA 2x10-3 CA 2x10-4
5.00	125,000	6,400-19,200 16,000-48,000 40,000-120,000 100,000-300,000	20,000,000	25,000,000	32,500,000	CA 3x5-1 CA 3x5-2 CA 3x5-3 CA 3x5-4
8.00	200,000	10,240-30,720 25,600-76,800 64,000-192,000 160,000-480,000	32,000,000	40,000,000	52,000,000	CA 3x8-1 CA 3x8-2 CA 3x8-3 CA 3x8-4
12.00	300,000	15,360-46,080 38,400-115,200 96,000-288,000 240,000-720,000	48,000,000	60,000,000	78,000,000	CA 3x12-1 CA 3x12-2 CA 3x12-3 CA 3x12-4

**Specifications**

- Mechanical stop – 2", 3" bore:  
must be provided .09 inch (2.3 mm) before end of stroke
- Oil type – ATF
- Materials –  
Steel body - with black oxide finish  
Piston rod - high tensile steel, hardened & chrome plated  
Rod end button - hardened steel with black oxide finish  
Return spring - zinc plated

Model	Return Force lbs (N)	Return Time sec	Shipping Weight lbs (kg)
CA 2 x 2	48-63 (214-280)	0.25	28.2 (12.79)
CA 2 x 4	34-63 (151-280)	0.50	32.6 (14.79)
CA 2 x 6	34-90 (151-400)	0.60	37.2 (16.87)
CA 2 x 8	51-144 (227-641)	0.70	42.6 (19.32)
CA 2 x 10	35-101 (156-449)	0.80	50.2 (22.77)
CA 3 x 5	59-156 (262-694)	0.60	63.8 (28.94)
CA 3 x 8	62-162 (275-721)	0.80	73.6 (33.38)
CA 3 x 12	60-160 (267-712)	1.20	89.4 (40.55)



For inventory, lead times, and kit lookup, visit [www.pdnplu.com](http://www.pdnplu.com)

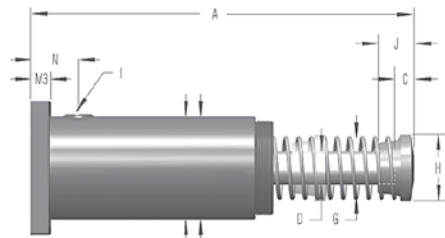
M36

**Parker Hannifin Corporation**  
Pneumatic Division  
Richland, Michigan  
[www.parker.com/pneumatics](http://www.parker.com/pneumatics)

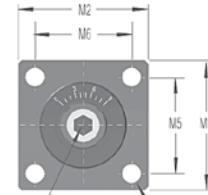
**CA 2, CA 3 Bore Series – Heavy Duty Models, Self-Compensating**

Dimensions on following page.

**Rear Flange**

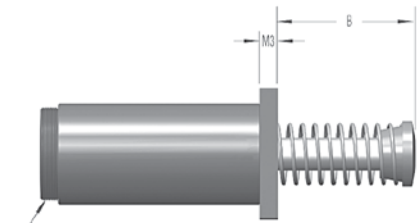


AA & SA adjustable models only  
 4.25 (108.0 mm) – 2" bore  
 5.50 (139.7 mm) – 3" bore



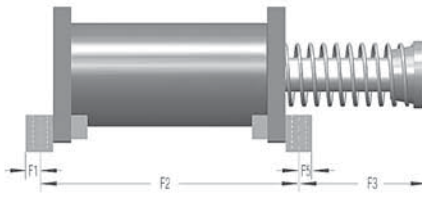
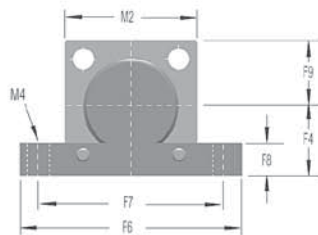
5/16" (8 mm)  
 hex socket adjuster  
 adjustable models only

**Front Flange**

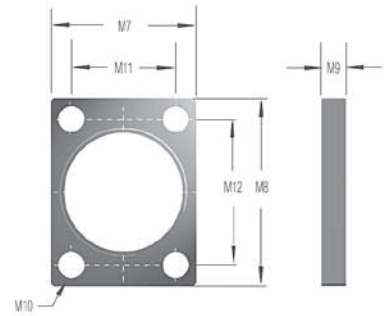


M100 x 2 – 2" bore  
 M130 x 2 – 3" bore

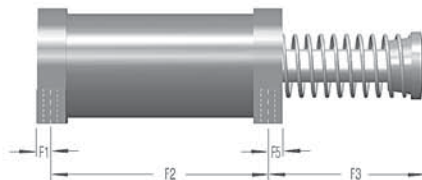
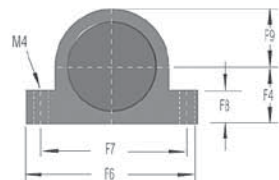
**2" Bore Foot Mount**



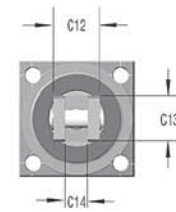
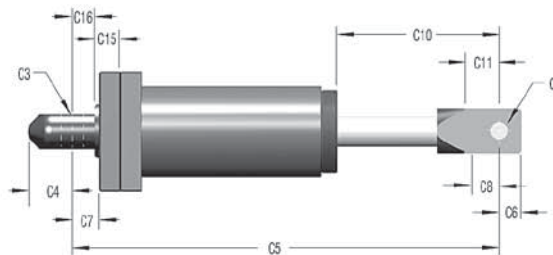
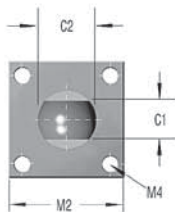
**Rectangular Flange**



**3" Bore Foot Mount**



**Clevis Mount**



CA 2, CA 3 Bore Series – Heavy Duty Models, Self-Compensating

Size	Stroke	A	B	C	D	G	H	I	J	N	V	C1	C2	C3	C4	C5	C6	C7	C8	C10	C11	
CA 2x2	2.00 (50.8)	12.31 (312.7)	4.31 (109.5)	0.82 (20.8)	1.38 (35.1)	3.06 (77.7)	2.75 (69.9)	3/4 NPT	1.38 (35.1)	3.50 (88.9)	4.25 (108.0)	1.50 (38.1)	2.25 (57.2)	1.005 (25.5)	1.00 (25.4)	17.00 (431.8)	1.00 (25.4)	2.00 (50.8)	1.50 (38.1)	6.05 (153.7)	2.06 (52.3)	
CA 2x4	4.00 (101.6)	16.31 (414.0)	6.31 (160.3)	0.82 (20.8)	1.38 (35.1)	3.06 (77.7)	2.75 (69.9)	3/4 NPT	1.38 (35.1)	3.50 (88.9)	4.25 (108.0)	1.50 (38.1)	2.25 (57.2)	1.005 (25.5)	1.00 (25.4)	21.00 (533.4)	1.00 (25.4)	2.00 (50.8)	1.50 (38.1)	8.05 (204.4)	2.06 (52.3)	
CA 2x6	6.00 (152.4)	20.31 (515.9)	8.31 (211.1)	0.82 (20.8)	1.38 (35.1)	3.63 (92.2)	2.75 (69.9)	3/4 NPT	1.38 (35.1)	3.50 (88.9)	4.25 (108.0)	1.50 (38.1)	2.25 (57.2)	1.005 (25.5)	1.00 (25.4)	25.00 (635.0)	1.00 (25.4)	2.00 (50.8)	1.50 (38.1)	10.05 (255.2)	2.06 (52.3)	
CA 2x8	8.00 (203.2)	25.31 (642.9)	11.31 (287.3)	1.82 (46.2)	1.38 (35.1)	4.00 (101.6)	3.63 (92.2)	3/4 NPT	2.38 (60.5)	3.50 (88.9)	4.25 (108.0)	1.50 (38.1)	2.25 (57.2)	1.005 (25.5)	1.00 (25.4)	29.00 (736.6)	1.00 (25.4)	2.00 (50.8)	1.50 (38.1)	12.05 (306.1)	0.75 (19.0)	
CA 2x10	10.00 (254)	29.31 (744.5)	13.31 (338.1)	1.82 (46.2)	1.38 (35.1)	4.50 (114.3)	4.25 (108.0)	3/4 NPT	2.38 (60.5)	3.50 (88.9)	4.25 (108.0)	1.50 (38.1)	2.25 (57.2)	1.005 (25.5)	1.00 (25.4)	33.00 (838.2)	1.00 (25.4)	2.00 (50.8)	1.50 (38.1)	14.05 (356.9)	1.06 (26.9)	
CA 3x5	5.00 (127)	19.25 (489.0)	8.25 (209.6)	2.00 (50.8)	1.75 (44.5)	4.75 (120.7)	4.38 (111.3)	3/4 NPT	2.75 (69.9)	3.13 (79.5)	5.50 (139.7)	1.50 (38.1)	2.25 (57.2)	1.01 (25.5)	1.00 (25.4)	23.00 (584.2)	1.00 (25.4)	2.00 (50.8)	1.50 (38.1)	9.05 (229.9)	1.12 (28.4)	
CA 3x8	8.00 (203.2)	25.25 (641.4)	11.25 (285.8)	2.00 (50.8)	1.75 (44.5)	4.75 (120.7)	4.38 (111.3)	3/4 NPT	2.75 (69.9)	3.13 (79.5)	5.50 (139.7)	1.50 (38.1)	2.25 (57.2)	1.01 (25.5)	1.00 (25.4)	29.00 (736.6)	1.00 (25.4)	2.00 (50.8)	1.50 (38.1)	12.05 (306.1)	1.12 (28.4)	
CA 3x12	12.00 (304.8)	35.03 (889.8)	17.03 (432.6)	2.00 (50.8)	1.75 (44.5)	4.84 (122.9)	4.38 (111.3)	3/4 NPT	2.75 (69.9)	3.13 (79.5)	5.50 (139.7)	1.50 (38.1)	2.25 (57.2)	1.01 (25.5)	1.00 (25.4)	38.78 (985)	1.00 (25.4)	2.00 (50.8)	1.50 (38.1)	17.83 (452.9)	1.12 (28.4)	
Size	Stroke	C12	C13	C14	C15	C16	F1	F2	F3	F4	F5	F6	F7	F8	F9	M1	M2	M3	M4	M5	M6	
CA 2x2	2.00 (50.8)	3.5 (88.9)	2.00 (50.8)	1.50 (38.1)	1.25 (31.8)	1.75 (44.5)	0.63 (16.0)	9.5 (241.3)	3.44 (87.4)	3.13 (79.5)	0.63 (16.0)	8.00 (203.2)	6.50 (165.1)	1.50 (38.1)	2.75 (69.9)	5.50 (139.7)	5.50 (139.7)	0.75 (19.1)	0.66 (16.8)	4.38 (111.3)	4.38 (111.3)	
CA 2x4	4.00 (101.6)	3.5 (88.9)	2.00 (50.8)	1.50 (38.1)	1.25 (31.8)	1.75 (44.5)	0.63 (16.0)	11.5 (292.1)	5.44 (138.2)	3.13 (79.5)	0.63 (16.0)	8.00 (203.2)	6.50 (165.1)	1.50 (38.1)	2.75 (69.9)	5.50 (139.7)	5.50 (139.7)	0.75 (19.1)	0.66 (16.8)	4.38 (111.3)	4.38 (111.3)	
CA 2x6	6.00 (152.4)	3.5 (88.9)	2.00 (50.8)	1.50 (38.1)	1.25 (31.8)	1.75 (44.5)	0.63 (16.0)	13.5 (342.9)	7.44 (189.0)	3.13 (79.5)	0.63 (16.0)	8.00 (203.2)	6.50 (165.1)	1.50 (38.1)	2.75 (69.9)	5.50 (139.7)	5.50 (139.7)	0.75 (19.1)	0.66 (16.8)	4.38 (111.3)	4.38 (111.3)	
CA 2x8	8.00 (203.2)	3.5 (88.9)	2.00 (50.8)	1.50 (38.1)	1.25 (31.8)	1.75 (44.5)	0.63 (16.0)	15.5 (393.7)	10.44 (265.2)	3.13 (79.5)	0.63 (16.0)	8.00 (203.2)	6.50 (165.1)	1.50 (38.1)	2.75 (69.9)	5.50 (139.7)	5.50 (139.7)	0.75 (19.1)	0.66 (16.8)	4.38 (111.3)	4.38 (111.3)	
CA 2x10	10.00 (254.0)	3.5 (88.9)	2.00 (50.8)	1.50 (38.1)	1.25 (31.8)	1.75 (44.5)	0.63 (16.0)	17.5 (444.5)	12.44 (316.0)	3.13 (79.5)	0.63 (16.0)	8.00 (203.2)	6.50 (165.1)	1.50 (38.1)	2.75 (69.9)	5.50 (139.7)	5.50 (139.7)	0.75 (19.1)	0.66 (16.8)	4.38 (111.3)	4.38 (111.3)	
CA 3x5	5.00 (127.0)	3.5 (88.9)	2.00 (50.8)	1.50 (38.1)	1.25 (31.8)	1.75 (44.5)	1.00 (25.4)	10.25 (260.4)	8.50 (215.9)	3.15 (80.0)	1.00 (25.4)	10.00 (254.0)	8.50 (215.9)	1.73 (43.9)	3.15 (80.0)	6.00 (152.4)	6.50 (165.1)	1.00 (25.4)	0.66 (16.8)	4.88 (124.0)	5.38 (136.7)	
CA 3x8	8.00 (203.2)	3.5 (88.9)	2.00 (50.8)	1.50 (38.1)	1.25 (31.8)	1.75 (44.5)	1.00 (25.4)	13.25 (336.6)	11.50 (292.1)	3.15 (80.0)	1.00 (25.4)	10.00 (254.0)	8.50 (215.9)	1.73 (43.9)	3.15 (80.0)	6.00 (152.4)	6.50 (165.1)	1.00 (25.4)	0.66 (16.8)	4.88 (124.0)	5.38 (136.7)	
CA 3x12	12.00 (304.8)	3.5 (88.9)	2.00 (50.8)	1.50 (38.1)	1.25 (31.8)	1.75 (44.5)	1.00 (25.4)	17.25 (438.2)	17.28 (438.9)	3.15 (80.0)	1.00 (25.4)	10.00 (254.0)	8.50 (215.9)	1.73 (43.9)	3.15 (80.0)	6.00 (152.4)	6.50 (165.1)	1.00 (25.4)	0.66 (16.8)	4.88 (124.0)	5.38 (136.7)	
Size	M7		M8	M9	M10	M11	M12															
CA 3 A 3	Rectangular Flange		6.50 (165.1)	8.00 (203.2)	1.00 (25.4)	0.78 (19.8)	4.50 (114.3)	6.50 (165.1)														



For inventory, lead times, and kit lookup, visit [www.pdnplu.com](http://www.pdnplu.com)

M38

[www.comosocom](http://www.comosocom)

**Parker Hannifin Corporation**  
Pneumatic Division  
Richland, Michigan  
[www.parker.com/pneumatics](http://www.parker.com/pneumatics)



Features

Heavy Industrial Shock Absorbers CA 4 - Self-Compensating

CA 4" Bore Series of self-compensating shock absorbers are designed for extremely heavy duty applications and provide smooth deceleration under changing conditions. High energy capacities combined with wide effective weight ranges qualify these units to perform in the most demanding environments.

Applications include:

Foundry, steel, marine, lumber and other heavy equipment industries.



Operating information

Impact velocity range: 1 to 16.5 ft/sec (0.30 to 5 m/sec)  
Operating temperature: 10°F to 150°F (-12°C to 66°C)

Ordering information – CA 4 series, self-compensating

<b>CA</b>	<b>4</b>	x	<b>8</b>	<b>R</b>	-	<b>5</b>																																								
<table border="1"> <thead> <tr> <th colspan="2">Return method and accumulator style</th> </tr> </thead> <tbody> <tr> <td>CA</td> <td>Spring return, internal accumulator</td> </tr> <tr> <td>CAA</td> <td>Air return, external accumulator</td> </tr> <tr> <td>CSA</td> <td>Spring return, external accumulator</td> </tr> <tr> <td>CNA</td> <td>Self return (clevis), internal accumulator</td> </tr> </tbody> </table>	Return method and accumulator style		CA	Spring return, internal accumulator	CAA	Air return, external accumulator	CSA	Spring return, external accumulator	CNA	Self return (clevis), internal accumulator	<table border="1"> <thead> <tr> <th>Bore size</th> </tr> </thead> <tbody> <tr> <td>4</td> </tr> </tbody> </table>	Bore size	4		<table border="1"> <thead> <tr> <th>Stroke length</th> </tr> </thead> <tbody> <tr> <td>6</td> </tr> <tr> <td>8</td> </tr> <tr> <td>16</td> </tr> </tbody> </table>	Stroke length	6	8	16	<table border="1"> <thead> <tr> <th colspan="2">Mounting style</th> </tr> </thead> <tbody> <tr> <td>-F</td> <td>Front flange</td> </tr> <tr> <td>-R</td> <td>Rear flange</td> </tr> <tr> <td>-RP</td> <td>Rear standard</td> </tr> <tr> <td>-FP</td> <td>Front standard</td> </tr> <tr> <td>-FRP</td> <td>Front and rear standard</td> </tr> <tr> <td>-S</td> <td>Side foot mount</td> </tr> <tr> <td>-C</td> <td>Clevis mount</td> </tr> </tbody> </table>	Mounting style		-F	Front flange	-R	Rear flange	-RP	Rear standard	-FP	Front standard	-FRP	Front and rear standard	-S	Side foot mount	-C	Clevis mount		<table border="1"> <thead> <tr> <th colspan="2">Effective weight</th> </tr> </thead> <tbody> <tr> <td>-3</td> <td>Light</td> </tr> <tr> <td>-5</td> <td>Medium</td> </tr> <tr> <td>-7</td> <td>Heavy</td> </tr> </tbody> </table>	Effective weight		-3	Light	-5	Medium	-7	Heavy
Return method and accumulator style																																														
CA	Spring return, internal accumulator																																													
CAA	Air return, external accumulator																																													
CSA	Spring return, external accumulator																																													
CNA	Self return (clevis), internal accumulator																																													
Bore size																																														
4																																														
Stroke length																																														
6																																														
8																																														
16																																														
Mounting style																																														
-F	Front flange																																													
-R	Rear flange																																													
-RP	Rear standard																																													
-FP	Front standard																																													
-FRP	Front and rear standard																																													
-S	Side foot mount																																													
-C	Clevis mount																																													
Effective weight																																														
-3	Light																																													
-5	Medium																																													
-7	Heavy																																													

Stroke inches 1 inch = 25.4 mm	E3 max energy per cycle, inch lbs 1 in lb = .11 Nm	We effective weight lbs, 1 lb = .45 kg	E4 max energy per hour, in lbs/hour 1 in lb/hour = .11 Nm/hour			Model number
			Self-contained	A/O tank	A/O Re-circulating	
6.00	420,000	8,000-19,000	27,000,000	45,000,000	58,000,000	CA 4x6-3
6.00	420,000	19,000-41,000	27,000,000	45,000,000	58,000,000	CA 4x6-5
6.00	420,000	41,000-94,000	27,000,000	45,000,000	58,000,000	CA 4x6-7
8.00	560,000	11,000-25,000	30,000,000	50,000,000	65,000,000	CA 4x8-3
8.00	560,000	25,000-55,000	30,000,000	50,000,000	65,000,000	CA 4x8-5
8.00	560,000	55,000-125,000	30,000,000	50,000,000	65,000,000	CA 4x8-7
16.00	1,120,000	22,000-50,000	50,000,000	85,000,000	110,000,000	CA 4x16-3
16.00	1,120,000	50,000-110,000	50,000,000	85,000,000	110,000,000	CA 4x16-5
16.00	1,120,000	110,000-250,000	50,000,000	85,000,000	110,000,000	CA 4x16-7

Specifications

- Mechanical stop – 4" bore: must be provided .09 inch (2.3mm) before end of stroke
- Oil type – ATF
- Materials –
  - Steel body - with black oxide finish
  - Piston rod - high tensile steel, hardened & chrome plated
  - Rod end button - hardened steel with black oxide finish
  - Return spring - zinc plated

Model	Return Force lbs (N)	Return Time sec	Shipping Weight lbs (kg)
4 x 6	108-222 (480-1,000)	Consult Factory	132 (60)
4 x 8	71-222 (310-1,000)	Consult Factory	150 (68)
4 x 16	Consult Factory	Consult Factory	321 (146)



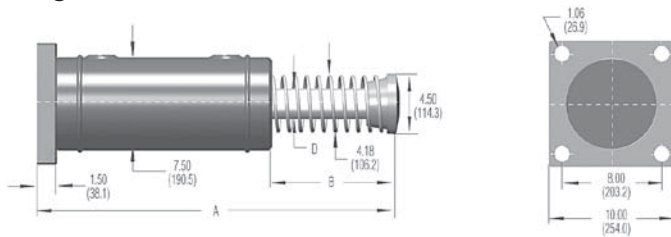
For inventory, lead time, and kit lookup, visit [www.pdnplu.com](http://www.pdnplu.com)

M39

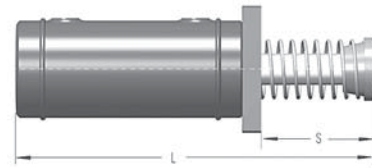
Parker Hannifin Corporation  
Pneumatic Division  
Richland, Michigan  
[www.parker.com/pneumatics](http://www.parker.com/pneumatics)

**CA 4" Bore Series – Heavy Duty Models, Self-Compensating**

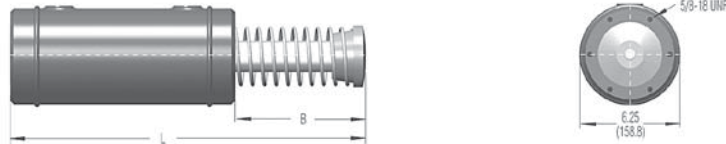
**Rear Flange**



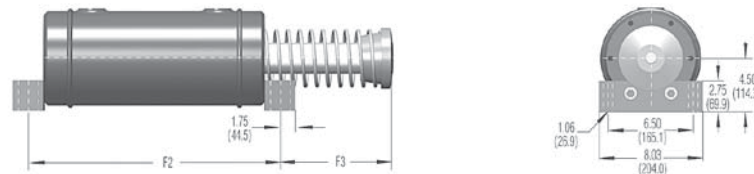
**Front Flange**



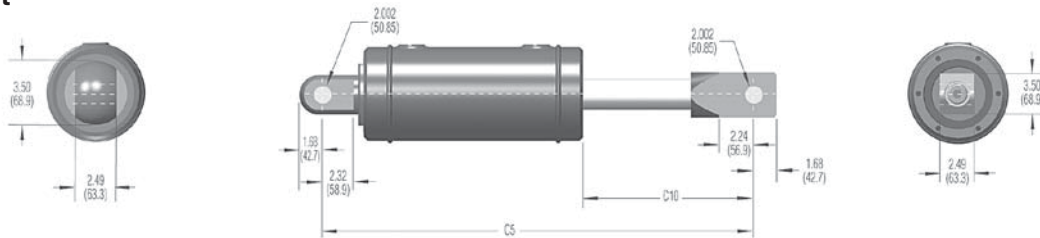
**Standard Mount**



**Side-Foot Mount**



**Clevis Mount**



Size	Stroke	A	B	D	H	L	S	C5	C10	F2	F3
CA 4 x 6	6.00 (152.4)	28.21 (716.5)	10.96 (278.4)	2.12 (53.8)	4.50 (114.3)	26.71 (678.4)	9.46 (240.3)	33.03 (839.0)	12.90 (327.7)	17.50 (447.5)	10.90 (276.9)
CSA 4 x 6	6.00 (152.4)	28.21 (716.5)	10.96 (278.4)	2.12 (53.8)	4.50 (114.3)	26.71 (678.4)	9.46 (240.3)	33.03 (839.0)	12.90 (327.7)	17.50 (447.5)	10.90 (276.9)
CAA 4 x 6	6.00 (152.4)	26.21 (665.7)	8.96 (227.6)	2.12 (53.8)	4.50 (114.3)	24.71 (628.4)	7.46 (188.0)	31.03 (788.2)	10.90 (276.9)	17.50 (447.5)	8.09 (205.5)
CNA 4 x 6	6.00 (152.4)	N/A	N/A	2.12 (53.8)	4.50 (114.3)	N/A	N/A	31.03 (788.2)	10.90 (276.9)	N/A	N/A
CA 4 x 8	8.00 (203.2)	32.31 (818.1)	12.96 (329.2)	2.12 (53.8)	4.50 (114.3)	30.71 (780.0)	11.46 (291.1)	37.03 (940.6)	14.90 (378.5)	19.50 (495.3)	12.09 (307.1)
CSA 4 x 8	8.00 (203.2)	32.31 (818.1)	12.96 (329.2)	2.12 (53.8)	4.50 (114.3)	30.71 (780.0)	11.46 (291.1)	37.03 (940.6)	14.90 (378.5)	19.50 (495.3)	12.09 (307.1)
CAA 4 x 8	8.00 (203.2)	30.21 (767.3)	10.96 (278.4)	2.12 (53.8)	4.50 (114.3)	28.71 (729.2)	9.46 (240.3)	35.03 (889.8)	12.90 (327.7)	19.50 (495.3)	10.09 (256.3)
CNA 4 x 8	8.00 (203.2)	N/A	N/A	2.12 (53.8)	4.50 (114.3)	N/A	N/A	35.03 (889.8)	12.90 (327.7)	N/A	N/A
CA 4 x 16	16.00 (406.4)	51.21 (1,300.7)	23.96 (608.6)	2.50 (63.5)	5.00 (127.0)	49.71 (1,262.6)	22.46 (570.5)	56.03 (1,423.2)	25.90 (657.9)	27.50 (698.5)	23.09 (586.5)
CSA 4 x 16	16.00 (406.4)	51.21 (1,300.7)	23.96 (608.6)	2.50 (63.5)	5.00 (127.0)	49.71 (1,262.6)	22.46 (570.5)	56.03 (1,423.2)	25.90 (657.9)	27.50 (698.5)	23.09 (586.5)
CAA 4 x 16	16.00 (406.4)	46.21 (1,173.7)	18.96 (481.6)	2.50 (63.5)	5.00 (127.0)	44.71 (1,135.6)	17.46 (443.5)	51.03 (1,296.2)	20.90 (530.9)	27.50 (698.5)	18.09 (459.5)
CNA 4 x 16	16.00 (406.4)	N/A	N/A	2.50 (63.5)	5.00 (127.0)	N/A	N/A	51.03 (1,296.2)	20.90 (530.9)	N/A	N/A

Features

Heavy Industrial Shock Absorbers A 2 and A 3 - Adjustable

A2 and A3 Series adjustable shock absorbers are capable of decelerating heavy duty loads. These reliable units replace the former 2" and 3" large bore adjustable shock absorbers.

Energy capacity ratings are 228% of former models. In addition, effective weight ranges have increased dramatically, resulting in the capability of handling a wider range of applications and increases in velocity. The units are easily adjusted by means of a 5/16 inch (8 mm) hex socket adjuster located at the bottom of the outer body. These dependable shock absorbers are maintenance free and are available self-contained or for use with an external air/oil tank.

Features include a considerably reduced outer diameter, internal accumulator and threaded mounting brackets, easily adaptable to the front or rear of the outer body.

Applications include:

Foundry, steel, marine, lumber, and other heavy equipment industries.



Operating information

Impact velocity range:	0.33 to 16.5 ft/sec (0.1 to 5 m/sec)
Operating temperature:	10°F to 150°F (-12°C to 66°C)

Ordering information – A 2 & A 3 series, adjustable

<b>A</b>	<b>2</b>	<b>x</b>	<b>8</b>	<b>-</b>	<b>R</b>
<b>Return method and accumulator style</b>	<b>Bore size</b>		<b>Stroke length</b>		<b>Mounting style</b>
<b>A</b> Spring return, internal accumulator	<b>2</b>		2		<b>-F</b> Front flange
<b>AA</b> Air return, external accumulator	<b>3*</b>		4		<b>-R</b> Rear flange
<b>SA</b> Spring return, external accumulator			5		<b>-RF</b> Front rectangular flange
<b>NA</b> Self return (clevis), internal accumulator			6		<b>-RR</b> Rear rectangular flange
					<b>-S</b> Side foot mount
					<b>-C</b> Clevis mount

\* A no button option is available on the 3" Bore only as a special.

Stroke inches 1 inch = 25.4 mm	E3 max energy per cycle, inch lbs 1 in lb = .11 Nm	We effective weight lbs, 1 lb = .45 kg	E4 max energy per hour, in lbs/hour 1 in lb/hour = .11 Nm/hour			Model number
			Self-contained	A/O tank	A/O Re-circulating	
2.00	32,000	560-170,000	9,600,000	12,000,000	15,600,000	<b>A 2x2</b>
4.00	80,000	510-160,000	12,000,000	15,000,000	19,500,000	<b>A 2x4</b>
6.00	120,000	570-190,000	14,400,000	18,000,000	23,500,000	<b>A 2x6</b>
8.00	170,000	580-200,000	16,800,000	21,000,000	27,000,000	<b>A 2x8</b>
10.00	210,000	720-250,000	19,200,000	24,000,000	31,000,000	<b>A 2x10</b>
5.00	140,000	1,050-340,000	20,000,000	25,000,000	32,500,000	<b>A 3x5</b>
8.00	250,000	1,200-400,000	32,000,000	40,000,000	52,000,000	<b>A 3x8</b>
12.00	390,000	1,350-450,000	48,000,000	60,000,000	78,000,000	<b>A 3x12</b>

Specifications

- Mechanical stop – must be provided .09 inch (2.3 mm) before end of stroke.
- Oil type – ATF
- Materials –
  - Steel body - with black oxide finish
  - Piston rod - high tensile steel, hardened & chrome plated
  - Return spring - zinc plated
 To avoid reducing heat dissipation, do not paint.
- Adjustment - After installation of the shock absorber, cycle the machine a number of times. Turn the hex socket adjuster against the scale marked 0 to 9, until optimum deceleration is achieved (i.e. smooth deceleration throughout the stroke).
- Hard impact at the start of stroke-turn adjuster toward 9.
- Hard set-down at the end of stroke-turn adjuster toward 0.

Model	Return Force lbs (N)	Return Time sec	Shipping Weight lbs (kg)
<b>A 2 x 2</b>	48-63 (214-280)	0.25	31.5 (14.29)
<b>A 2 x 4</b>	34-63 (151-280)	0.50	36.9 (16.74)
<b>A 2 x 6</b>	34-90 (151-400)	0.60	42.6 (19.32)
<b>A 2 x 8</b>	51-144 (227-641)	0.70	49.1 (22.27)
<b>A 2 x 10</b>	35-101 (156-449)	0.80	57.8 (26.22)
<b>A 3 x 5</b>	59-156 (262-694)	0.60	72.1 (32.70)
<b>A 3 x 8</b>	62-162 (275-721)	0.80	84.9 (38.51)
<b>A 3 x 12</b>	60-160 (267-712)	1.20	105.0 (47.63)



For inventory, lead time, and kit lookup, visit [www.pdnplu.com](http://www.pdnplu.com)

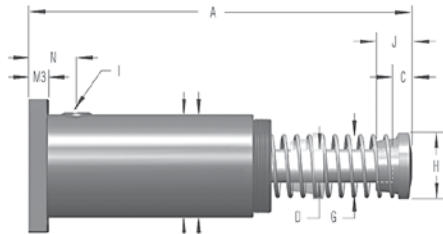
M41

Parker Hannifin Corporation  
Pneumatic Division  
Richland, Michigan  
[www.parker.com/pneumatics](http://www.parker.com/pneumatics)

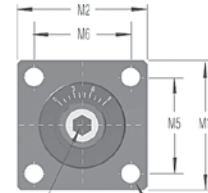
**A 2", A 3" Bore Series – Heavy Duty Models, Adjustable**

Dimensions on following page.

**Rear Flange**

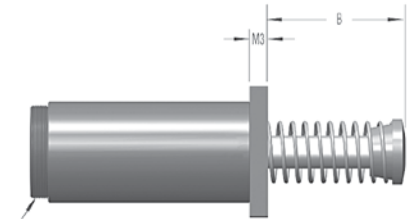


AA & SA adjustable models only  
 4.25 (108.0 mm) – 2" bore  
 5.50 (139.7 mm) – 3" bore



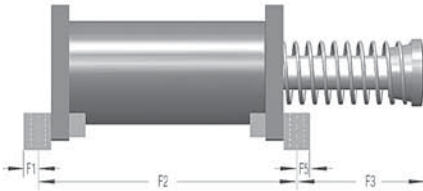
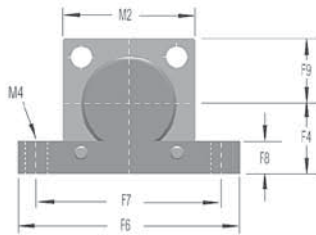
5/16" (8 mm)  
 hex socket adjuster  
 adjustable models only

**Front Flange**

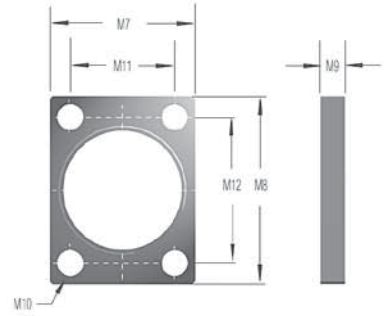


M100 x 2 – 2" bore  
 M130 x 2 – 3" bore

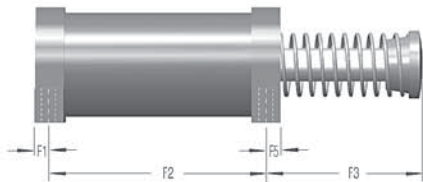
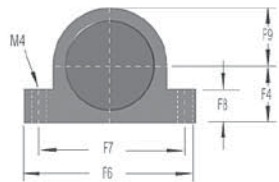
**2" Bore Foot Mount**



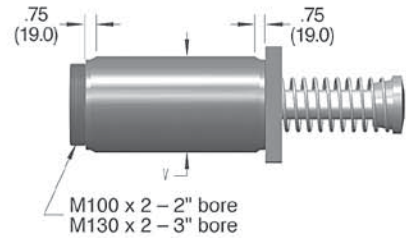
**Rectangular Flange**



**3" Bore Foot Mount**

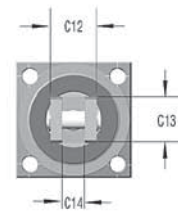
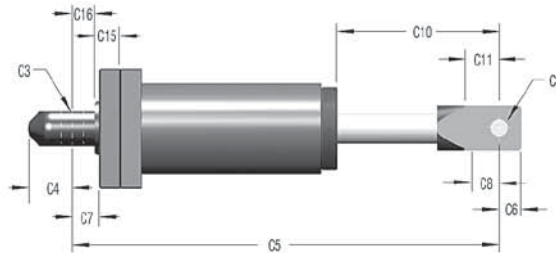
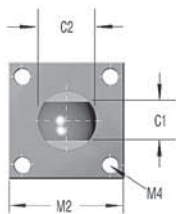


**2" & 3" Bore Models**



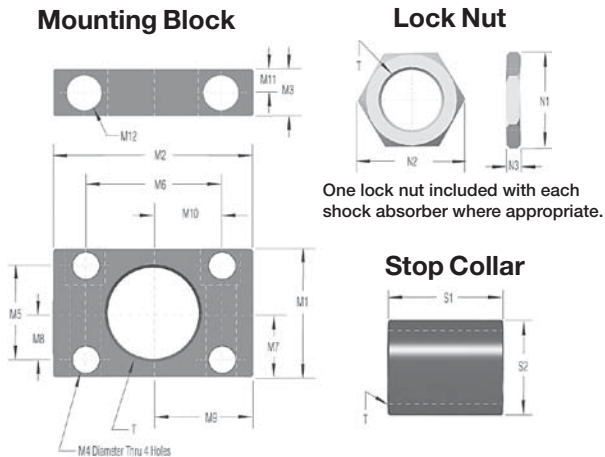
M100 x 2 – 2" bore  
 M130 x 2 – 3" bore

**Clevis Mount**





Mounting Blocks



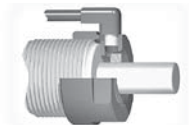
Side load adapters are available for select models, see pages N48 and N49.

Inches (mm)

Used With	Mounting Block														Lock Nut			Stop Collar			
	Part #	T	M1	M2	M3	M4	M5	M6	M7	M8	M9	M10	M11	M12	Part #	N1	N2	N3	Part #	S1	S2
MC 10E MC 10M	N/A	M8x0.75 M8x1	-	-	-	-	-	-	-	-	-	-	-	-	250-0362 250-0482	.43 (11)	.49 (12.5)	.12 (3.0)	N/A	-	-
MC 25	250-0306	3/8-32 UNF	1.00 (25.4)	1.50 (38.1)	.56 (14.2)	See DIM M12	0 (0)	1.00 (25.4)	.50 (12.7)	0 (0)	.75 (19.1)	.50 (12.7)	.28 (7.1)	.18 Dia. Thru .31 C Bore x .20 Deep #6-32 Soc. Hd. Screw	250-0404	.50 (12.7)	.56 (14.2)	.09 (2.3)	250-0406	.81 (20.6)	.56 (14.2)
MC 25M	250-0307	M10x1	1.00 (25.4)	1.50 (38.1)	.56 (14.2)	See DIM M12	0 (0)	1.00 (25.4)	.50 (12.7)	0 (0)	.75 (19.1)	.50 (12.7)	.28 (7.1)	.45 Dia. Thru (.8) C Bore x (.5) Deep M4x7 Soc. Hd. Screw	250-0315	.55 (14.0)	.59 (15.0)	.12 (3.0)	250-0408	.79 (20.0)	.56 (14.3)
MA 35 MC 75	250-0308	1/2-20 UNF	1.00 (25.4)	1.50 (38.1)	.56 (14.2)	See DIM M12	0 (0)	1.00 (25.4)	.50 (12.7)	0 (0)	.75 (19.1)	.50 (12.7)	.28 (7.1)	.18 Dia. Thru .31 C Bore x .20 Deep #6-32 Soc. Hd. Screw	250-0405	.62 (16.5)	.70 (17.8)	.13 (3.3)	250-0407	.81 (20.6)	.62 (15.7)
MA 35M MC 75M	250-0309	M12x1	1.00 (25.4)	1.50 (38.1)	.56 (14.2)	See DIM M12	0 (0)	1.00 (25.4)	.50 (12.7)	0 (0)	.75 (19.1)	.50 (12.7)	.28 (7.1)	.45 Dia. Thru (.8) C Bore x (.5) Deep M4x7 Soc. Hd. Screw	250-0317	.55 (14.0)	.63 (16.0)	.16 (4.0)	250-0409	.79 (20.0)	.63 (16.0)
MA 150 MC 150 SC 190	250-0318	9/16-18 UNF	1.37 (34.8)	1.81 (46.0)	.62 (15.7)	.22 (5.6)	1.00 (25.4)	1.38 (35.1)	.69 (17.5)	.50 (12.7)	.91 (23.1)	.69 (17.5)	.31 (7.9)	.21 Dia. Thru .32 C Bore x .32 Deep #10-32 Soc. Hd. Screw	250-0231	.88 (22.4)	1.00 (25.4)	.31 (7.9)	250-0271	.75 (19.1)	.69 (17.5)
MA 150M MC 150M SC 190M	250-0352	M14x1.5	1.10 (28.0)	1.77 (45.0)	.63 (16.0)	.18 (4.5)	0 (0)	1.38 (35.0)	.55 (14.0)	0 (0)	.89 (22.5)	.69 (17.5)	.31 (7.9)	.45 Dia. Thru (.8) C Bore x (.5) Deep M4x7 Soc. Hd. Screw	250-0233	.67 (17.0)	.77 (19.6)	.20 (5.0)	250-0272	.79 (20.0)	.69 (17.5)
MC 225 MA 225 MVC 225 SC 300	250-0401	3/4-16 UNF	1.50 (38.1)	2.00 (50.8)	.62 (15.7)	.22 (5.6)	1.12 (28.4)	1.50 (38.1)	.75 (19.1)	.56 (14.2)	1.00 (25.4)	.75 (19.1)	.31 (7.9)	.22 Dia. Thru .33 C Bore x .45 Deep #10-32 Soc. Hd. Screw	250-0399	1.00 (25.4)	1.15 (29.2)	.25 (6.4)	250-0403	1.25 (38.1)	1.00 (25.4)
MC 225M MA 225M MVC 225M SC 300M	250-0353	M20x1.5	1.38 (35.0)	1.85 (47.0)	.63 (16.0)	.22 (5.6)	1.00 (25.4)	1.38 (35.0)	.69 (17.5)	.50 (12.7)	.93 (23.5)	.69 (17.5)	.31 (7.9)	.5 Dia. Thru (.10) C Bore x (.10) Deep M5x8 Soc. Hd. Screw	250-0207	.94 (24.0)	1.10 (28.0)	.24 (6.0)	250-0410	.98 (25.0)	.98 (25.0)
MC 600 MA 600 MVC 600 SC 650 MA 900 MVC 900 SC 925	250-0402	1-12 UNF	1.50 (38.1)	2.00 (50.8)	.62 (15.7)	.22 (5.6)	1.12 (28.4)	1.50 (38.1)	.75 (19.1)	.56 (14.2)	1.00 (25.4)	.75 (19.1)	.31 (7.9)	.22 Dia. Thru .33 C Bore x .45 Deep #10-32 Soc. Hd. Screw	250-0400	1.25 (31.8)	1.44 (36.6)	.25 (6.4)	250-0275	1.75 (44.5)	1.25 (31.8)
MC600ML	N/A	-	-	-	-	-	-	-	-	-	-	-	-	-	250-0239	1.25 (31.8)	1.44 (36.6)	.31 (7.9)	250-0263	1.77 (45.0)	1.26 (32.0)
MC 600M MA 600M MVC 600M SC 650M MA 900M MVC 900M SC 925M	250-0044	M25x1.5	1.38 (35.0)	1.85 (47.0)	.63 (16.0)	.22 (5.6)	1.00 (25.4)	1.38 (35.0)	.69 (17.5)	.50 (12.7)	.93 (23.5)	.69 (17.5)	.31 (7.9)	.5 Dia. Thru (.10) C Bore x (.10) Deep M5x8 Soc. Hd. Screw	250-0040	1.18 (30.0)	1.36 (34.6)	.31 (7.9)	250-0276	1.77 (45.0)	1.26 (32.0)

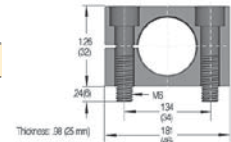
Air Bleed Collar

Used with	Model	Part number
MC 150 M	SP-14	10781-000
MC 225 M	SP-20	10782-000
MC 600 M	SP-25	10783-000



Clamp

Used with	Model	Part number
MC 600 M	MB-25	10780-000

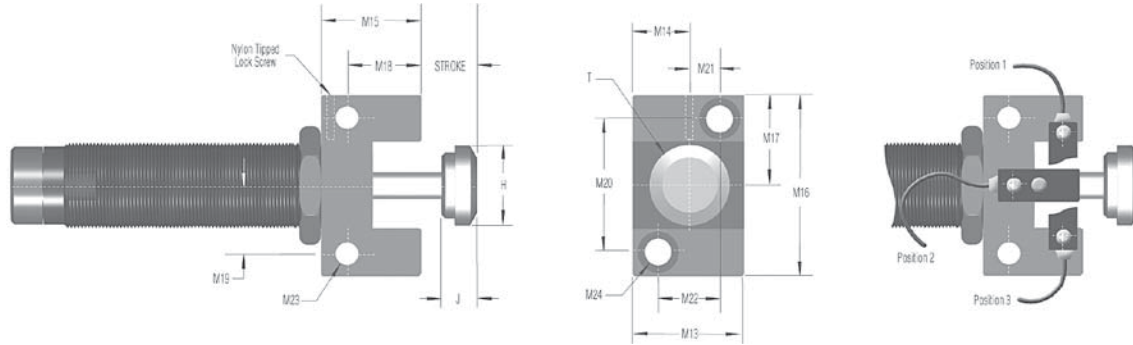


For inventory, lead times, and kit lookup, visit [www.pdnplu.com](http://www.pdnplu.com)

M44

Parker Hannifin Corporation  
Pneumatic Division  
Richland, Michigan  
[www.parker.com/pneumatics](http://www.parker.com/pneumatics)

StopLight™



StopLight™ Switches are available in both NPN and PNP styles. Part numbers are 250-3 NPN and 250-3 PNP, respectively. The switches can be used with any StopLight mounting blocks.

\* A complete StopLight assembly includes mounting block, proximity switch and steel button. Use the table below to order MC Series buttons. Steel buttons are an integral part of series MA and SC2 and MVC units. Shock absorbers are ordered separately.

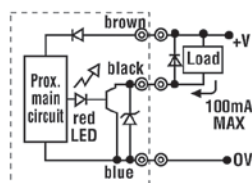
Used With	Part #	T	H	J	M13	M14	M15	M16	M17	M18	M19	M20	M21	M22	M23	M24
MA 150 MC 150* SC 190	250-0377	9/16-18 UNF	.47 (11.9)	.43 (10.9)	.75 (19.0)	.38 (22.3)	.88 (22.3)	1.25 (31.8)	.63 (15.9)	.57 (14.5)	.44 (11.1)	.88 (22.2)	.19 (4.7)	.38 (9.5)	.180 (4.6)	.315 (8.0)
MC 150M* SC 190M	250-0378	M14x1.5	.47 (11.9)	.43 (10.9)	.75 (19.0)	.38 (22.3)	.88 (22.3)	1.25 (31.8)	.63 (15.9)	.57 (14.5)	.44 (11.1)	.88 (22.2)	.19 (4.7)	.38 (9.5)	.180 (4.6)	.315 (8.0)
MC 225* MA 225 MVC 225 SC 300	250-0379	3/4-16 UNF	.66 (16.8)	.43 (10.9)	.94 (23.8)	.47 (11.9)	.94 (23.8)	1.56 (39.6)	.78 (19.8)	.63 (16.0)	.55 (14.0)	1.10 (28.0)	.24 (6.0)	.47 (12.0)	.216 (5.5)	.394 (10.0)
MC 225M MA 225M MVC 225M SC 300M	250-0380	M20x1.5	.66 (16.8)	.43 (10.9)	.94 (23.8)	.47 (11.9)	.94 (23.8)	1.56 (39.6)	.78 (19.8)	.63 (16.0)	.55 (14.0)	1.10 (28.0)	.24 (6.0)	.47 (12.0)	.216 (5.5)	.394 (10.0)
MC 600* MA 600 MVC 600 MA 900 MVC 900 SC 650 SC 925	250-0381	1-12 UNF	.90 (22.9)	.43 (10.9)	1.18 (30.0)	.59 (15.0)	1.00 (25.4)	1.75 (44.5)	.88 (22.3)	.63 (16.0)	.63 (16.0)	1.26 (32.0)	.31 (8.0)	.63 (16.0)	.216 (5.5)	.394 (10.0)
MC 600M* MA 600M MVC 600M MA 900M MVC 900M SC 650M SC 925M	250-0382	M25x1.5	.90 (22.9)	.43 (10.9)	1.18 (30.0)	.59 (15.0)	1.00 (25.4)	1.75 (44.5)	.88 (22.3)	.63 (16.0)	.63 (16.0)	1.26 (32.0)	.31 (8.0)	.63 (16.0)	.216 (5.5)	.394 (10.0)

Model	Steel button part number
MA 150	250-0383
MC 150, MC 150M	250-0111
MC 225, MC 225M	250-0112
MC 600, MC 600M	250-0113

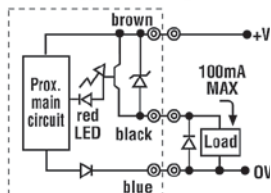
Inches (mm)

Specifications

250-3 NPN NPN-type Proximity Switch



250-3 PNP PNP-type Proximity Switch



- Supply voltage – 10 to 27 VDC Ripple p to p 10% max
- Current consumption – 15 mA max (at 24 VDC)
- Control output – 3-Wire Output: 100 mA max  
Voltage Impression: 30 VDC max  
Residual Voltage: 1 VDC max
- Operator indicator – Red LED; Power off = dark; Stand By = Dim Light
- Detection – Bright Light
- Operating Temperature – 14°F to 140°F, -10°C to 60°C (At holding: 86°F to 176°F; 30°C to 80°C)
- Humidity – 45 to 85% RH (At holding: 35 to 95% RH)
- Variation due to ±20% max of detecting distance at 68°F (20°C)
- Temperature Fluctuation – with a temperature range of 14°F to 140° F (-10°C to 60°C)
- Variation due to ±5% max of detecting distance at 12/24 VDC
- Voltage fluctuation – when operated within 10 to 27 VDC
- Residual voltage 1V max (Load current at 100 mA)
- Insulation resistance – 10M Ω min (at 500 VDC)
- Dielectric resistance – 1,000 VAC 50/60Hz for 1 minute
- Degree of protection – IP67 (IEC144)



For inventory, lead time, and kit lookup, visit [www.pdnplu.com](http://www.pdnplu.com)

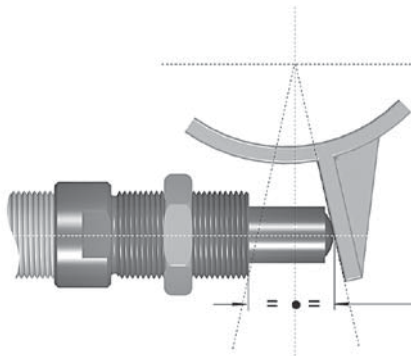
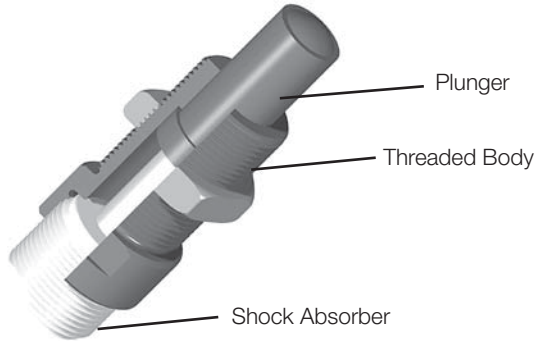
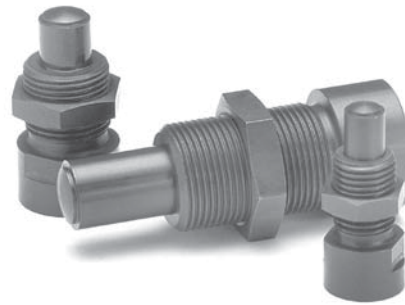
M45

**Miniature Shock Absorber Side Load Adapters**

**For Side Load in Excess of 3°**

With side load impact angles of more than 3° the operating lifetime of the shock absorber reduces rapidly due to increased wear of the rod bearings. The optional side load adapter provides a long lasting solution.

Material: Threaded body and plunger, hardened high tensile steel



**Problem:** Rotary motion of the striking surface creates side load, which develops a bending moment on the piston rod. This can bend the rod in some cases. In all cases, side load will reduce seal and bearing life.

**Solution:** Use side load adapter.

**Formula:**  $\alpha = \tan^{-1} \left( \frac{s}{2 \cdot R_s} \right)$        $R_{smin} = \frac{s}{2 \cdot \tan \alpha_{max}}$

**Example:**  $s = .98$  (25mm)       $\alpha_{max} = 25^\circ$  (adapter 250-0560)

$R_s = 3.94$  (100mm)       $R_{smin} = \frac{.98}{2 \cdot \tan 25}$

$\alpha = \tan^{-1} \left( \frac{.98}{2 \cdot 3.94} \right)$        $R_{smin} = 1.05$  (27mm)

$\alpha = (7.09)^\circ$

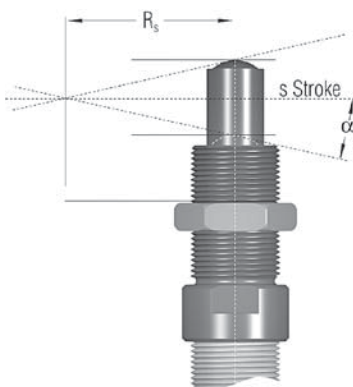
$\alpha$  = angle of impact

$\alpha_{max}$  = maximum angle of impact

$s$  = stroke

$R_s$  = radius

$R_{smin}$  = minimum r



Industrial Shock Absorbers

**M**



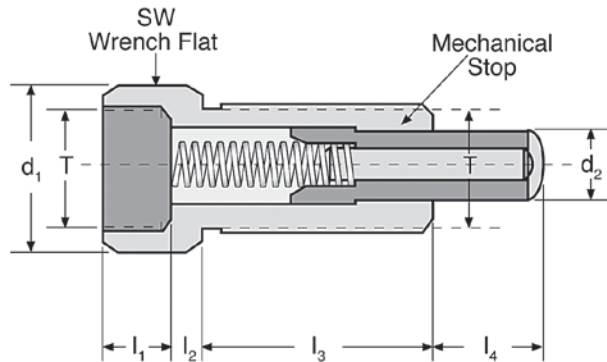
For inventory, lead times, and kit lookup, visit [www.pdnplu.com](http://www.pdnplu.com)

M46

**Parker Hannifin Corporation**  
Pneumatic Division  
Richland, Michigan  
[www.parker.com/pneumatics](http://www.parker.com/pneumatics)



Miniature Shock Absorber Side Load Adapters



MC, MVC series model	SC series model	MA series model	Side load adapter	T	d1	d2	l1	l2	l3	l4	SW	Maximum side load (α)
MC 150M	N/A	MA 150M	250-0558	M14 x 1.5	0.70 (18)	0.35 (9)	0.31 (8)	0.15 (4)	0.78 (20)	0.49 (12.5)	0.62 (16)	25°
MC 225M	N/A	N/A	250-0559	M20 x 1.5	0.94 (24)	0.47 (12)	0.39 (10)	0.15 (4)	0.78 (20)	0.49 (12.5)	0.86 (22)	25°
MC 600M	N/A	N/A	250-0560	M25 x 1.5	1.18 (30)	0.62 (16)	0.39 (10)	0.23 (6)	1.50 (38)	0.98 (25)	1.06 (27)	25°
N/A	SC 190M-880*	N/A	250-0080	M14 x 1.5	0.70 (18)	0.35 (9)	0.39 (10)	0.15 (4)	1.02 (26)	0.62 (16)	0.62 (16)	25°
MVC 225M-880*	SC 300M-880*	MA 225M-880*	250-0081	M20 x 1.5	0.94 (24)	0.47 (12)	0.39 (10)	0.15 (4)	1.25 (32)	0.75 (19)	0.86 (22)	25°
MVC 600M-880*	SC 650M-880*	MA 600M-880*	250-0082	M25 x 1.5	1.18 (30)	0.62 (16)	0.39 (10)	0.23 (6)	1.50 (38)	0.98 (25)	1.06 (27)	25°

Inches (mm)

Notes:

1. Side load not to exceed 5". Maximum side load depends on application, shock absorber model, and stroke length.
2. The side load adapter can only be installed on select metric shock absorbers without rod end button.

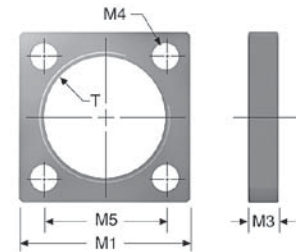
Accessories – Magnum

Square and Rectangular Flanges

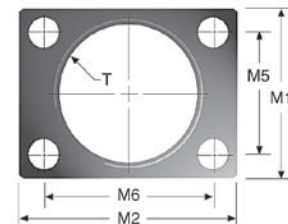
Used with	Square flange	Rectangular flange	T	M1	M2	M3	M4	M5	M6
MA 33 ML 33 MC 33		250-0016	1-1/4-12 UNF	1.50 (38.1)	2.00 (50.8)	0.38 (9.5)	.219 (5.6)	1.12 (28.4)	1.62 (41.2)
MA 33M ML 33M MC 33M	N/A	250-0293	M33x1.5	1.62 (41.1)	2.12 (53.8)	0.38 (9.5)	.278 (7.1)	1.10 (28.0)	1.65 (42.0)
MA 36 ML 36 MC 36		250-0633	1-3/8-12 UNF	1.75 (44.4)	2.00 (50.8)	0.38 (9.5)	.219 (5.6)	1.12 (28.4)	1.62 (41.2)
MA 36M ML 36M MC 36M	N/A	N/A	N/A	N/A	N/A	N/A	N/A	N/A	N/A
MA 45 ML 45 MC 45	250-0023	250-0024	1-3/4-12 UN	2.25 (57.2)	3.00 (76.2)	0.50 (12.7)	0.34 (8.7)	1.62 (41.2)	2.38 (60.5)
MA 45M ML 45M MC 45M	250-0298	250-0299	M45x1.5	2.25 (57.2)	3.00 (76.2)	0.50 (12.7)	0.35 (8.8)	1.62 (41.2)	2.38 (60.5)
MA 64 ML 64 MC 64	250-0028	N/A	2-1/2-12 UN	3.50 (88.9)	N/A	0.62 (15.9)	0.41 (10.4)	2.75 (69.6)	N/A
MA 64M ML 64M MC 64M	250-0302	N/A	M64x2	3.50 (88.9)	N/A	0.62 (15.9)	0.41 (10.4)	2.75 (69.6)	N/A

Inches (mm)

Square Flange



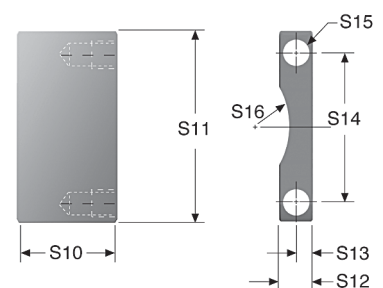
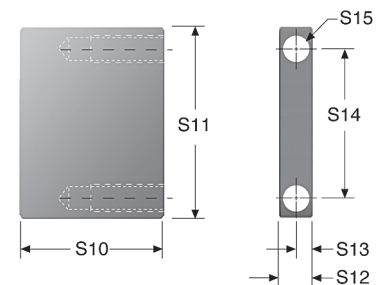
Rectangular Flange



Stop Bars

Used with	Part #	S10	S11	S12	S13	S14	S15	S16
MA 33 ML 33 MC 33	250-0426	1.28 (32.5)	1.50 (38.1)	0.38 (9.7)	0.19 (4.8)	1.12 (28.4)	10-32 UNF	N/A
MA 33M ML 33M MC 33M	250-0427	1.28 (32.5)	1.50 (38.1)	0.38 (9.7)	0.19 (4.8)	1.12 (28.4)	M5x0.8	N/A
MA 36 ML 36 MC 36	250-0426	1.28 (32.5)	1.50 (38.1)	0.38 (9.7)	0.19 (4.8)	1.12 (28.4)	10-32 UNF	N/A
MA 36M ML 36M MC 36M	N/A	N/A	N/A	N/A	N/A	N/A	N/A	N/A
MA 45 ML 45 MC 45	250-0428	1.03 (26.2)	2.25 (57.2)	0.63 (16.0)	0.31 (7.9)	1.62 (41.3)	5/16-24 UNF	N/A
MA 45M ML 45M MC 45M	250-0639	1.03 (26.2)	2.25 (57.2)	0.63 (16.0)	0.31 (7.9)	1.62 (41.3)	M8x1.25	N/A
MA 6450 MA 64100 ML 6425 ML 6450 MC 6450 MC 64100	250-0430	1.44 (36.5)	3.50 (88.9)	0.50 (12.7)	0.25 (6.4)	2.75 (69.8)	3/8-24 UNF	1.37 (34.8)
MA 6450M MA 64100M ML 6425M ML 6450M MC 6450M MC 64100M	250-0640	1.44 (36.5)	3.50 (88.9)	0.50 (12.7)	0.25 (6.4)	2.75 (69.8)	M10x1.5	1.37 (34.8)
MA 64150 MC 64150	250-0432	2.31 (57.7)	3.50 (88.9)	0.50 (12.7)	0.25 (6.4)	2.75 (69.8)	3/8-24 UNF	1.37 (34.8)
MA 64150M MC 64150M	250-0641	2.31 (57.7)	3.50 (88.9)	0.50 (12.7)	0.25 (6.4)	2.75 (69.8)	M10x1.5	1.37 (34.8)
MAA 64150 MCA 64150	250-0435	2.18 (55.4)	3.50 (88.9)	0.50 (12.7)	0.25 (6.4)	2.75 (69.8)	3/8-24 UNF	1.37 (34.8)
MAA 64150M MCA 64150M	250-0649	2.18 (55.4)	3.50 (88.9)	0.50 (12.7)	0.25 (6.4)	2.75 (69.8)	M10x1.5	1.37 (34.8)

Inches (mm)



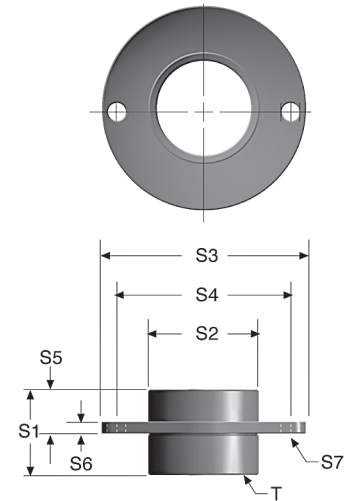
Hard metric stop bars available upon request.

Stop bars come in pairs, two bars per package.

Accessories – Magnum

Flanged Stop Collars

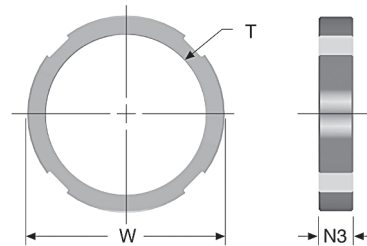
Used with	Part #	T	S1	S2	S3	S4	S5	S6	S7
MA 33 ML 33 MC 33	250-0070	1-1/4-12 UNF	2.00 (50.8)	1.50 (38.1)	2.50 (63.5)	2.00 (50.8)	0.88 (22.4)	0.25 (6.4)	0.282 (7.16)
MA 33M ML 33M MC 33M	250-0071	M33x1.5	2.00 (50.8)	1.50 (38.1)	2.50 (63.5)	2.00 (50.8)	0.88 (22.4)	0.25 (6.4)	0.282 (7.16)
MA 36 ML 36 MC 36 MA 36M ML 36M MC 36M	N/A	N/A	N/A	N/A	N/A	N/A	N/A	N/A	N/A
MA 45 ML 45 MC 45	250-0072	1-3/4-12 UN	1.85 (47.0)	2.25 (57.2)	3.25 (82.6)	2.75 (69.6)	0.88 (22.4)	0.25 (6.4)	0.282 (7.16)
MA 45M ML 45M MC 45M	250-0073	M45x1.5	1.85 (47.0)	2.25 (57.2)	3.25 (82.6)	2.75 (69.9)	0.88 (22.4)	0.25 (6.4)	0.282 (7.16)
MA 6450 MA 64100 ML 6425 ML 6450 MC 6450 MC 64100	250-0074	2-1/2-12 UN	2.25 (57.2)	3.00 (76.2)	4.25 (108.0)	3.50 (88.9)	1.00 (25.4)	0.38 (9.7)	0.282 (7.16)
MA 6450M MA 64100M ML 6425M ML 6450M MC 6450M MC 64100M	250-0075	M64x2	2.25 (57.2)	3.00 (76.2)	4.25 (108.0)	3.50 (88.9)	1.00 (25.4)	0.38 (9.7)	0.282 (7.16)
MA 64150 MC 64150	250-0076	2-1/2-12 UN	3.13 (79.4)	3.00 (76.2)	4.25 (108.0)	3.50 (88.9)	1.00 (25.4)	0.38 (9.7)	0.282 (7.16)
MA 64150M MC 64150M	250-0077	M64x2	3.13 (79.4)	3.00 (76.2)	4.25 (108.0)	3.50 (88.9)	1.00 (25.4)	0.38 (9.7)	0.282 (7.16)



Inches (mm)

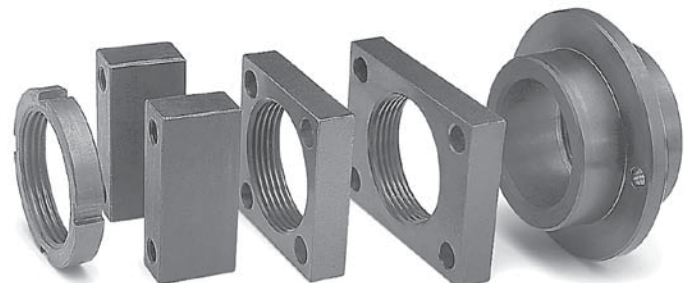
Lock Nuts

Used with	Part #	T	W	N3
MA 33 ML 33 MC 33	250-0038	1-1/4-12 UN	1.50 (38.1)	0.25 (6.4)
MA 33M ML 33M MC 33M	250-0292	M33x1.5	1.56 (39.6)	0.25 (6.4)
MA 36 ML 36 MC 36	250-0631	1-3/8-12 UNF	1.75 (44.5)	0.25 (6.4)
MA 36M ML 36M MC 36M	250-0537	M36x1.5	1.75 (44.5)	0.25 (6.4)
MA 45 ML 45 MC 45	250-0041	1-3/4-12 UN	2.25 (57.2)	0.37 (9.4)
MA 45M ML 45M MC 45M	250-0297	M45x1.5	2.25 (57.2)	0.37 (9.4)
MA 64 ML 64 MC 64	250-0042	2-1/2-12 UN	3.00 (76.2)	0.37 (9.4)
MA 64M ML 64M MC 64M	250-0302	M64x2	3.00 (76.2)	0.37 (9.4)



One lock nut included with each shock absorber where appropriate.

Inches (mm)



For inventory, lead time, and kit lookup, visit [www.pdnplu.com](http://www.pdnplu.com)

M49

**Side-Foot Mount Assembly**



Used With	Part #	Used With	Part #
MA 33 ML 33 MC 33	250-0015	MA 6450 MA 64100 ML 6425 ML 6450 MC 6450 MC 64100	250-0030
MA 33M ML 33M MC 33M	250-0294		
MA 36 ML 36 MC 36	N/A	MA 6450M MA 64100M ML 6425M ML 6450M MC 6450M MC 64100M	250-0306
MA 36M ML 36M MC 36M	N/A		
MA 45 ML 45 MC 45	250-0025	MA 64150 MC 64150	250-0300
MA 45M ML 45M MC 45M	250-0300	MA 64150M MC 64150M	250-0306

**Clevis Mount Assembly**

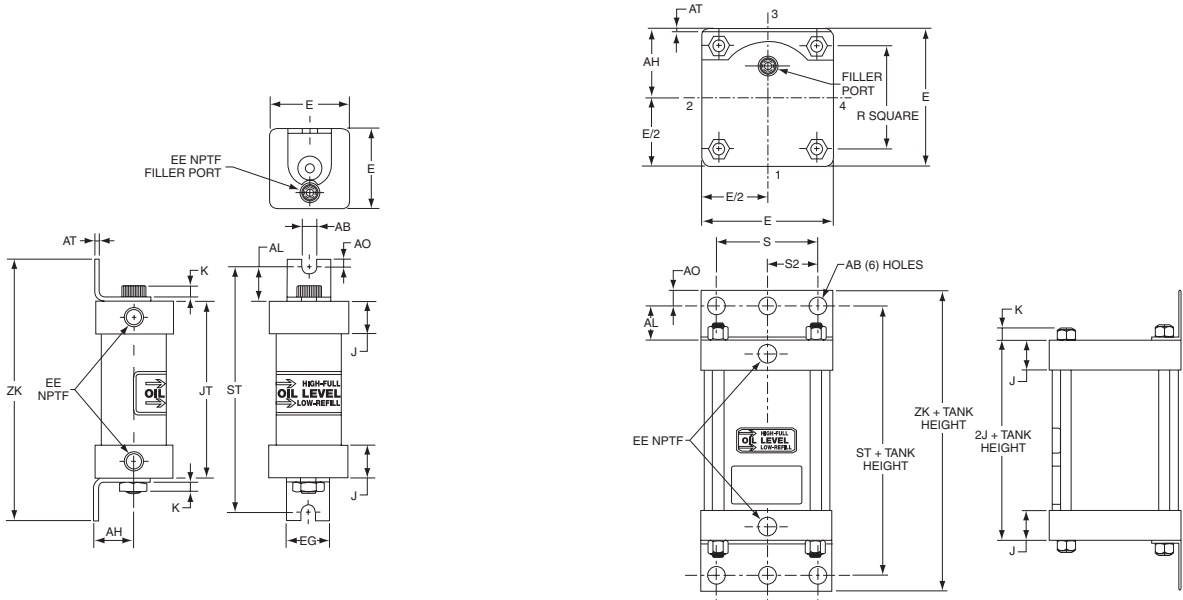


Used With	Part #	Used With	Part #
MA 33 ML 33 MC 33 MAS MLS MCS	250-0225	ML 6425 ML 6425M MA 6450 ML 6450 MC 6450	250-0625 250-0626 250-0625
MA 33M ML 33M MC 33M MAS 33M MLS 33M MCS 33M	250-0323	MA 6450M ML 6450M MC 6450M	250-0626
MAN 33 MLN 33 MCN 33 MAA 33 MLA 33 MCA 33	250-0018	MA 64100 MC 64100 MAN 64150 MCN 64150 MAA 64150 MCA 64150	250-0625 250-0626 250-0625
MAN 33M MLN 33M MCN 33M MAA 33M MLA 33M MCA 33M	250-0322	MAN 64150M MCN 64150M MAA 64150M MCA 64150M	250-0626
MA 45 ML 45 MC 45	250-0324	MA 64150 MCA 64150 MAS 64150 MCS 64150	250-0627
MA 45M ML 45M MC 45M	250-0325	MA 64150M MCA 64150M MAS 64150M MCS 64150M	250-0628

**Air-Oil Tanks**

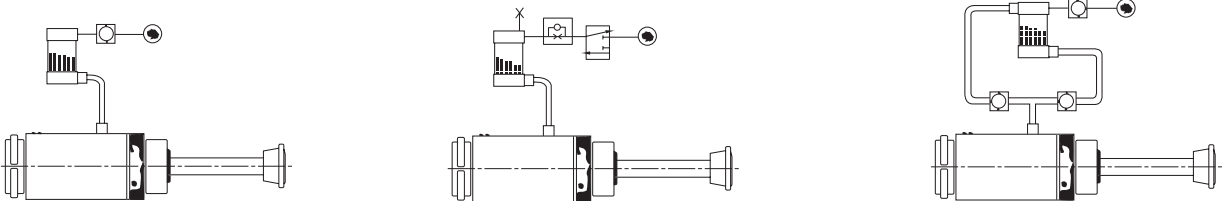
**1-1/4" Bore**

**3-1/4" to 8" Bores**

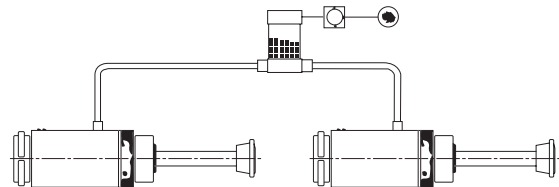


Bore Size	E	J	K	R	S	AB	AH	AL	AO	AT	EE	ST	ZK	EG	JT
1-1/4	1-27/32	3/4	1/4	–	–	11/32	29/32	25.32	3/16	31/32	1/8	5-5/8	6	1	4-1/16
3-1/4	3-3/4	1-3/16	3/16	2.76	2-3/4	9/16	1-15/16	1-1/4	1/2	1/8	1/2	5	6	–	–
6	6-1/2	1.41	7/16	4.88	5-1/4	13/16	3-1/4	1-3/8	5/8	3/16	3/4	5-3/4	7	–	–
8	8-1/2	1.44	9/16	6.44	7-1/8	13/16	4-1/4	1-13/16	11/16	1/4	3/4	6-5/8	8	–	–

**Mounting and Circuits**



1. The piston rod is immediately returned to its extended position after completing the stroke.
2. The piston rod remains in its retracted position until it is signaled to return. Special bleed-down type check valve is required for this circuit.
3. A recirculating cooling circuit allows warm oil to return to the tank while cool oil refills the shock absorber. A recirculating cooling circuit substantially increases the shock absorber's hourly energy capacity.



4. When connecting more than one shock absorber to an Air-Oil Tank, use caution in selecting the proper reservoir capacity. For two shock absorbers, the next largest Air-Oil Tank Size is usually adequate.

**Capacity (maximum)**

Model	Oil temp (°F)	Max. pressure (psi)	Capacity (cubic inches)	Recommended shock absorber size
1.25CB4TKU x 2.00	200	100	2.4	MC 3325 MC 3350
3.25CB4TKU x 5.00	200	100	41.4	MC 4525 MC 64150
6.00CB4TKU x 9.00	200	100	254.5	1-1/2 x 5 - 3 x 12
8.00CB4TKU x 15.00	200	100	754	4 x 6 - 4 x 16
8.00 CB4TKUS x 15.00	200	100	754	4 x 6 - 4 x 16

S = 1 1/2 NPTF ports in cap face



For inventory, lead time, and kit lookup, visit [www.pdnplu.com](http://www.pdnplu.com)

M51



For inventory, lead times, and kit  
lookup, visit [www.pdnplu.com](http://www.pdnplu.com)

M52

**Parker Hannifin Corporation**  
Pneumatic Division  
Richland, Michigan  
[www.parker.com/pneumatics](http://www.parker.com/pneumatics)

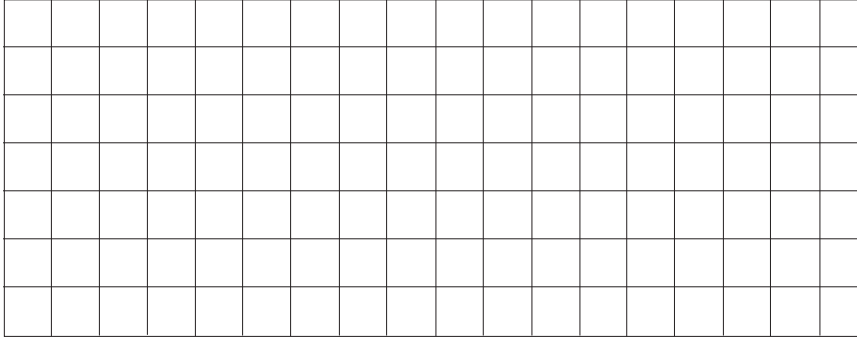


*Fax completed form to 330-334-3335 or email to actuatorsales@parker.com.*

**CONTACT INFORMATION:**

Name \_\_\_\_\_ Phone \_\_\_\_\_  
 Company \_\_\_\_\_ email \_\_\_\_\_  
 City, State, Zip \_\_\_\_\_

**APPLICATION SKETCH**



*Please include the critical dimensions in your sketch.*  
*In order to achieve the best solution, it is important that you provide as much information as possible.*  
*For other considerations, please use another sheet of paper.*

**OPERATING ENVIRONMENT**

<b>Media (check one)</b> <input type="checkbox"/> Air <input type="checkbox"/> Oil <input type="checkbox"/> Other _____	<b>Pressure</b> Min. _____ Max. _____	<b>Temperature</b> Ambient _____ Fluid _____	<b>Conditions</b> <input type="checkbox"/> Std. Factory <input type="checkbox"/> Chemical <input type="checkbox"/> Corrosive <input type="checkbox"/> Outdoor <input type="checkbox"/> Other _____
---	---	--	---

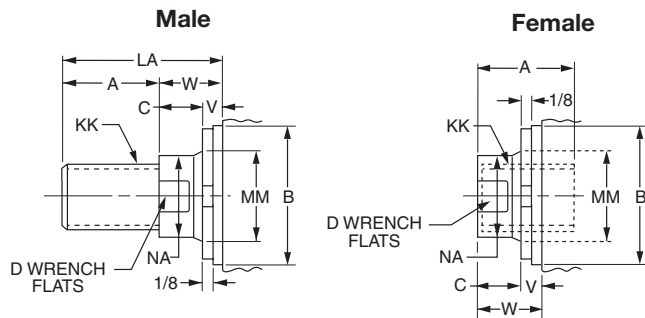
**TECHNICAL SPECIFICATIONS**

<b>Mounting/Cylinder Orientation</b> Style (refer to catalog) _____ <input type="checkbox"/> Vertical <input type="checkbox"/> Rod Up <input type="checkbox"/> Rod Down <input type="checkbox"/> Horizontal Degrees from Vertical _____	<b>Port Type</b> Head: <input type="checkbox"/> NPTF <input type="checkbox"/> BSPP <input type="checkbox"/> SAE Cap: <input type="checkbox"/> NPTF <input type="checkbox"/> BSPP <input type="checkbox"/> SAE Position # (refer to catalog) _____ Other _____	<b>Cushions</b> Head: <input type="checkbox"/> Yes <input type="checkbox"/> No Cap: <input type="checkbox"/> Yes <input type="checkbox"/> No Position # (refer to catalog) _____
---	---	---

**LOAD INFORMATION**

Push (lbs) _____	Extend Speed (inches/sec) _____	Dwell Time _____
Pull (lbs) _____	Retract Speed (inches/sec) _____	Cycles/Min _____
Known Side Load (lbs) _____		

**ROD END DETAILS**



*If rod end is different from above, please submit sketch. Piston rod diameter and rod end threads vary with the application. Please supply the dimensions below.*

**Male Rod End**

KK = \_\_\_\_\_  
 A = \_\_\_\_\_  
 LA or LAF = \_\_\_\_\_

**Female Rod End**

KK = \_\_\_\_\_  
 A = \_\_\_\_\_  
 W or WF = \_\_\_\_\_

Check One	Rod End Connection	Case
<input type="checkbox"/>	Fixed and rigidly guided	
<input type="checkbox"/>	Pivoted and rigidly guided	
<input type="checkbox"/>	Supported but not rigidly guided	
<input type="checkbox"/>	Pivoted and rigidly guided	
<input type="checkbox"/>	Pivoted and rigidly guided	
<input type="checkbox"/>	Pivoted and rigidly guided	

Application Fax Forms  
 Part Number Index  
 Safety Guide  
 Offer of Sale  
 Application Fax Forms, Part Number Index, Safety Guide, Offer of Sale



For inventory, lead times, and kit lookup, visit [www.pdnplu.com](http://www.pdnplu.com)

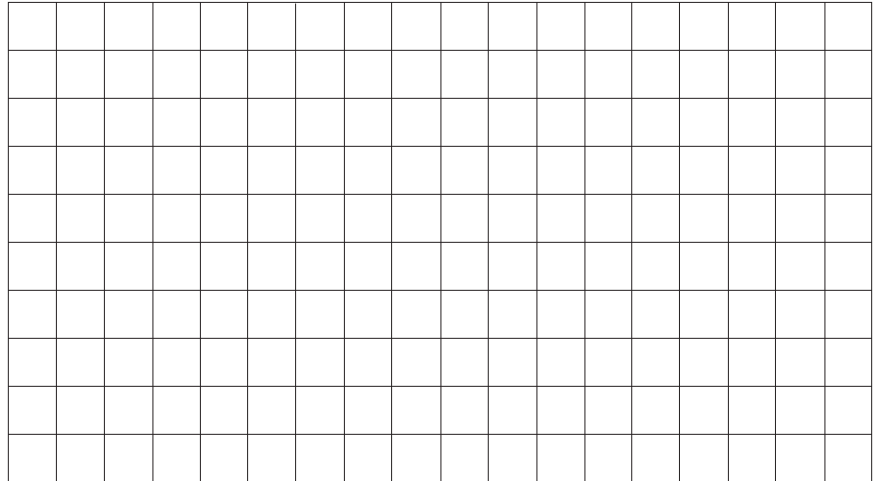


Fax completed form to 330-334-3335 or email to actuator\_sales@parker.com.

**CONTACT INFORMATION:**

Name \_\_\_\_\_ Phone \_\_\_\_\_  
 Company \_\_\_\_\_ email \_\_\_\_\_  
 City, State, Zip \_\_\_\_\_

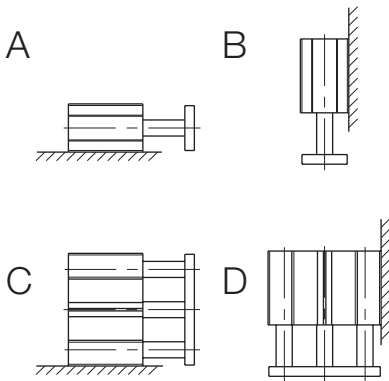
**APPLICATION SKETCH**



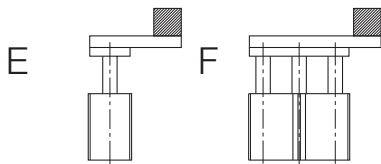
Please include the critical dimensions in your sketch.

In order to achieve the best solution, it is important that you provide as much information as possible.

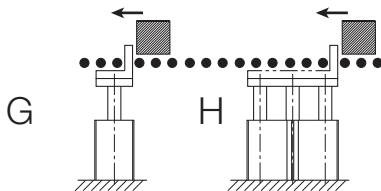
**EXAMPLES  
 ORIENTATION**



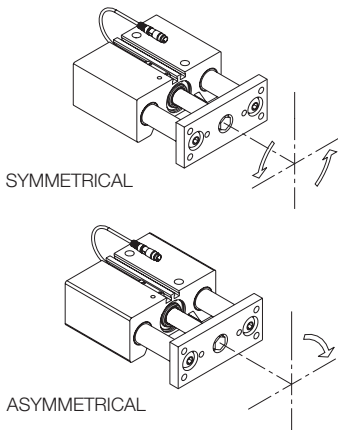
**VERTICAL LOAD**



**LOAD STOPPING**



**TORSIONAL REQUIREMENTS**



**APPLICATION DETAILS**

1. **Application Type:** Using the examples on the left, circle the letter that most closely matches your application.  
**A B C D E F G H**
2. **Required stroke (mm):** \_\_\_\_\_
3. **Force Requirements (lbs):**  
 Extend \_\_\_\_\_ Retract \_\_\_\_\_
4. **Side Loading (lbs):** \_\_\_\_\_
5. **Load Stopping:**  
 Weight (lbs) \_\_\_\_\_ Velocity (in/sec) \_\_\_\_\_
6. **Torques (lb-in):** \_\_\_\_\_
7. **Torsional Requirements (check one):**  
 Symmetrical  Asymmetrical
8. **Cycle Times:**
  - a. Duty Cycles (cycles/hr) \_\_\_\_\_
  - b. Extend Time \_\_\_\_\_
  - c. Retract Time \_\_\_\_\_
  - d. Dwell Time \_\_\_\_\_

**ENVIRONMENTAL CONDITIONS**

1. **Operating Temperature:**  
 Max \_\_\_\_\_ Min \_\_\_\_\_
2. **Contamination (check one):**  
 Particle  Liquid

**Other Special Considerations for the Application:**

\_\_\_\_\_  
 \_\_\_\_\_  
 \_\_\_\_\_

Application Fax Forms, Part Number Index, Safety Guide, Offer of Sale  
**N**



For inventory, lead time, and kit lookup, visit www.pdnplu.com



Model No.	Section / Page No.	Model No.	Section / Page No.	Model No.	Section / Page No.	Model No.	Section / Page No.
240.....	G29	261109920.....	B130	880386336.....	B70	1458050075.....	B34, B35, B80, B81, B103
250.....	G30	261109921.....	B130	886600000.....	L22	1458050100.....	B34, B35, B80, B81
2010.....	G29, G83	261109922.....	B130	886620000.....	L22	1458050138.....	B34, B35, B80, B81
2040.....	G83	261110600.....	C57	887790016.....	G112	1458050175.....	B34, B35, B80, B81
3010.....	G29, G83	261210800.....	C57	887790020.....	G112	1458060031.....	B35, B81
4041.....	G89, G92	261211000.....	C57	887790025.....	G112	1458060050.....	B35, B80, B81, B103
4041.....	L12	695800000.....	B83, B87	887790032.....	G112	1458060075.....	B35, B80, B81, B103
11052.....	G94	695810000.....	B83, B87	887790040.....	G112	1458060100.....	B35, B80, B81
11053.....	G94	695820000.....	B83, B87	887790050.....	G112	1458060138.....	B35, B80, B81
11054.....	G94	695830000.....	B83, B87	913090000.....	L30	1458060175.....	B35, B80, B81
11055.....	G94	695900000.....	B83, B87	913090100.....	L30	1459030000.....	E122, E143, E147, E160
11056.....	G94	695910000.....	B83, B87	1337390125.....	K2	1467140000.....	E122, E143, E147, E160
11057.....	G94	695920000.....	B83, B87	1337390150.....	K2	1467150000.....	E122, E143, E147, E160
11058.....	G94	695930000.....	B83, B87	1337390175.....	K2	1472340062.....	B77
11059.....	G94	831830000.....	C65	1337390188.....	K2	1472340100.....	B77
11060.....	G94	833010048.....	C65	1347570031.....	K2	1472340138.....	B77
11061.....	G94	833010100.....	C65	1347570038.....	K2	1472340175.....	B77
11062.....	G94	833010124.....	C65	1347570044.....	K2	1481740062.....	B77
11063.....	G94	853550003.....	L28	1347570050.....	K2	1481740100.....	B77
11064.....	G94	853550006.....	L26, L28	1347570063.....	K2	1481740138.....	B77
11065.....	G94	853550012.....	L26, L28	1347570075.....	K2	1481740175.....	B77
11066.....	G94	853560012.....	L28	1347570088.....	K2	1493440002.....	C49
11067.....	G94	856640044.....	B35, B80	1347570100.....	K2	1493440003.....	C49
11068.....	G94	856640050.....	B35, B80, B103	1347570125.....	K2	1493440004.....	C49
11069.....	G94	856640075.....	B35, B80, B103	1442840000.....	K3	1493440005.....	C49
11070.....	G94	856640100.....	B35, B80	1458030044.....	B34, B35, B80, B81	9121719001.....	L25
11116.....	G94	856640138.....	B35, B80	1458030050.....	B34, B35, B80, B81	9121719002.....	L25
148275.....	L26	856640175.....	B35, B80	1458030075.....	B34, B35, B80, B81	9121719003.....	L25
148896.....	L26	859170003.....	L28	1458030088.....	B34, B35, B80, B81	9121719004.....	L25
148897.....	L26	859170006.....	L26, L28	1458030100.....	B34, B35, B80, B81	9121720601.....	J50
149109.....	L26	859170012.....	L26, L28	1458030125.....	B34, B35, B80, B81	9121720602.....	J50
32510125.....	K4	865130151.....	B84, B88	1458030150.....	B34, B35, B80, B81	9121720603.....	J50
32510250.....	K4	865130200.....	B84, B88	1458040044.....	B34, B35, B80, B81	9121720604.....	J50, J72
32510375.....	K4	865130250.....	B84, B88	1458040050.....	B34, B35, B80, B81	9121720605.....	J50, J72
32510500.....	K4	865130325.....	B84, B88	1458040075.....	B34, B35, B80, B81	9121720606.....	J50
32511215.....	K4	865130400.....	B84, B88	1458040088.....	B34, B35, B80, B81	9121720607.....	J50
32511225.....	K4	865130500.....	B84, B88	1458040100.....	B34, B35, B80, B81	9121720608.....	J50
32512525.....	K4	865130600.....	B84, B88	1458040125.....	B34, B35, B80, B81	9121720609.....	J50
32512538.....	K4	865130800.....	B84, B88	1458040150.....	B34, B35, B80, B81	9121720610.....	J50
32513838.....	K4	867340300.....	B130	1458050044.....	B34, B81	9121720611.....	J50
45020002.....	B70	867340300.....	C57	1458050050.....	B34, B35, B80, B81, B103	9121720612.....	J50
45040004.....	B70	867340400.....	B130			9121720613.....	J50
45060060.....	B70	867340600.....	B130			9121720614.....	J50
85356003.....	L28	867340900.....	B130			9121720615.....	J51
85356006.....	L28	875470006.....	L26			9121720616.....	J51
85356009.....	L28	876300100.....	K3			9121720617.....	J51
116760000.....	B83, B87	876300200.....	K3				
116770000.....	B83, B87	876300300.....	G129				
117030000.....	B83, B87	876300400.....	G129				
261109911.....	B130	876300500.....	K3				
261109916.....	B130	876310100.....	K3				
261109917.....	B130	876310200.....	K3				
261109918.....	B130	876310300.....	K3				
261109919.....	B130	880383836.....	B70				

Application Fax Forms
Part Number Index
Safety Guide
Offer of Sale
Application Fax Forms, Part Number Index, Safety Guide, Offer of Sale



For inventory, lead time, and kit lookup, visit [www.pdnplu.com](http://www.pdnplu.com)

Model No.	Section / Page No.	Model No.	Section / Page No.	Model No.	Section / Page No.	Model No.	Section / Page No.
9121720618.....	J51	1-1/2x2 .....	M33	20008FIL.....	G30, G83	20438FIL.....	G31
9121720619.....	J51	1-1/2x3-1/2.....	M33	20009FIL.....	G30, G83	20439FIL.....	G32
9121720620.....	J51	1-1/2x5 .....	M33	20024FIL.....	G27	20446FIL.....	G28
9121720621.....	J51	1-1/2x6-1/2.....	M33	20025FIL.....	G31	20451FIL.....	G30, G83
9121720622.....	J51	11089FIL.....	G94	20026FIL.....	G32	20452FIL.....	G30, G83
9121720623.....	J51	11090FIL.....	G94	20027FIL.....	G30, G83	20453FIL.....	G25, G83
9121720624.....	J51	11091FIL.....	G94	20028FIL.....	G30, G83	20459FIL.....	G28
9121720625.....	J51	11092FIL.....	G94	20037FIL.....	G28	20462FIL.....	G27
9121720626.....	J51	11093FIL.....	G94	20039FIL.....	G28	20463FIL.....	G27
9121720627.....	J51	11111x.....	G94	20092FIL.....	G27	20464FIL.....	G83
9121720628.....	J51	11112x.....	G94	20093FIL.....	G27	20465FIL.....	G83
9121720636.....	J50	11113x.....	G94	20094FIL.....	G27	20466FIL.....	G27
9121720637.....	J50	11114x.....	G94	20095FIL.....	G27	20467FIL.....	G27
9121720638.....	J51	11115x.....	G94	20096FIL.....	G27	20477FIL.....	G27
9121720639.....	J51	11118x.....	G94	20097FIL.....	G27	20478FIL.....	G27
9121742201.....	B131	11121x.....	G94	20157FIL.....	G30, G83	20480FIL.....	G30, G83
9121742202.....	B131	11122x.....	G94	20158FIL.....	G30, G83	20482FIL.....	G30, G83
9121742203.....	B131	11123x.....	G94	20161FIL.....	G28	20490FIL.....	G28
9121742204.....	B131	11124x.....	G94	20162FIL.....	G30, G83	2060FIL.....	G24, G83
9126344341.....	L13	11125x.....	G94	20163FIL.....	G30, G83	20806FIL.....	G22
9126344342.....	L13	11126x.....	G94	20166FIL.....	G28	20807FIL.....	G22
9126487202.....	L24	11128x.....	G94	20186FIL.....	G31	20808FIL.....	G22
9126487205.....	L24	11131x.....	G94	20187FIL.....	G32	20809FIL.....	G22
9126487302.....	L24	11132x.....	G94	20267FIL.....	G31	20810FIL.....	G22
9126487305.....	L24	11133x.....	G94	20268FIL.....	G32	20811FIL.....	G22
9126725404.....	B130	11134x.....	G94	20311FIL.....	G81, G83	20819FIL.....	G25, G83
9126725405.....	B130	11135x.....	G94	20312FIL.....	G83	20821FIL.....	G24, G83
9126725406.....	B130	11136x.....	G94	20313FIL.....	G81, G83	20822FIL.....	G24, G83
9126725406.....	C56	11138x.....	G94	20314FIL.....	G83	20849FIL.....	G33
9126725407.....	C56	11141x.....	G94	20338FIL.....	G83, G86	20850FIL.....	G33
9127385101.....	C56	11142x.....	G94	20339FIL.....	G24, G83	20851FIL.....	G33
9127394541.....	B132	11143x.....	G94	20340FIL.....	G83, G86	20971FIL.....	G26
9301054261.....	B127	11144x.....	G94	20349FIL.....	G83, G86	20976FIL.....	G83
9301054262.....	B127	11145x.....	G94	20350FIL.....	G24, G83, G86	20977FIL.....	G83
9301054264.....	B127	11146x.....	G94	20351FIL.....	G83	20PRL.....	K9
9301054266.....	B127	11148x.....	G94	20352FIL.....	G83	21107FIL.....	G70
9301054321.....	B131	11822FIL.....	G94	20353FIL.....	G25, G83	21108FIL.....	G70
9301054322.....	B131	11823FIL.....	G94	20354FIL.....	G83	21109FIL.....	G70
9301054323.....	B131	11824FIL.....	G94	20355FIL.....	G83	21110FIL.....	G70
9301054324.....	B131	11825FIL.....	G94	20356FIL.....	G25, G83	21119FIL.....	G85
9301054331.....	B131	11826FIL.....	G94	20357FIL.....	G83	21120FIL.....	G85
9301054332.....	B131	11827FIL.....	G94	20358FIL.....	G83	21121FIL.....	G85
9301054333.....	B131	12PRL.....	K9	20359FIL.....	G25, G83	21122FIL.....	G85
9301054334.....	B131	13039FIL.....	G93	20360FIL.....	G83	21125FIL.....	G82
086620S002.....	L24	145903000C.....	E122, E143, E147, E160	20361FIL.....	G83	21126FIL.....	G82
086620S005.....	L24			20362FIL.....	G25, G83	21127FIL.....	G82
086620T002.....	L24	146714000C.....	E122, E143, E147, E160	20363FIL.....	G83	21128FIL.....	G82
086620T005.....	L24			20408FIL.....	G29, G83	21129FIL.....	G82
086620T010.....	G92	146715000C.....	E122, E143, E147, E160	20432FIL.....	G31	21130FIL.....	G84
100-2801R.....	E119	16PRL.....	K9	20433FIL.....	G32	21131FIL.....	G84
10780-000.....	M44	20005FIL.....	G27	20434FIL.....	G30, G83	21132FIL.....	G84
10781-000.....	M44	20006FIL.....	G31	20435FIL.....	G30, G83	21133FIL.....	G84
10782-000.....	M44	20007FIL.....	G32	20436FIL.....	G83	21134FIL.....	G84
10783-000.....	M44			20437FIL.....	G83	21135FIL.....	G81

Application Fax Forms
Part Number Index
Safety Guide
Offer of Sale
Application Fax Forms, Part Number Index, Safety Guide, Offer of Sale



For inventory, lead times, and kit lookup, visit [www.pdnplu.com](http://www.pdnplu.com)

Model No.	Section / Page No.	Model No.	Section / Page No.	Model No.	Section / Page No.	Model No.	Section / Page No.
21136FIL.....	G81	250-0383 .....	M45	68LF-12M-4G .....	F56	BK01504MA1.....	B84
21137FIL.....	G81	2521-1/2-08.....	G93	68LF-12M-6G .....	F56	BK01504MA5.....	B84
21138FIL.....	G81	2521-1/4-04.....	G93	68LF-12M-8G .....	F56	BK02004MA1.....	B84
21139FIL.....	G81	2521-1/8-02.....	G93	68LF-3M-M3.....	F56	BK02004MA5.....	B84
21140FIL.....	G81	2521-3/8-06.....	G93	68LF-3M-M5.....	F56	BK02504MA1.....	B84
21141FIL.....	G81	25PRL.....	K9	68LF-4M-2G .....	F56	BK02504MA5.....	B84
21142FIL.....	G84	2MNR Series.....	B92	68LF-4M-4G .....	F56	BK03254MA1.....	B84
21143FIL.....	G84	3040FIL.....	G83	68LF-4M-M5.....	F56	BK03254MA5.....	B84
21144FIL.....	G84	3060FIL.....	G24, G83	68LF-6M-2G .....	F56	BK04004MA1.....	B84
21145FIL.....	G84	32-2801R.....	E119	68LF-6M-4G .....	F56	BK04004MA5.....	B84
21146FIL.....	G84	32PRL.....	K9	68LF-6M-6G .....	F56	BK05004MA1.....	B84
21148FIL.....	G84	369PLP-10M-4G.....	F56	68LF-6M-8G .....	F56	BK05004MA5.....	B84
21149FIL.....	G84	369PLP-10M-6G.....	F56	68LF-6M-M5.....	F56	BKS-S32M-05.....	B76
21150FIL.....	G84	369PLP-10M-8G.....	F56	68LF-8M-2G .....	F56	BKS-S32M-10.....	B76
21151FIL.....	G84	369PLP-12M-4G.....	F56	68LF-8M-4G .....	F56	CA 2x10-1.....	M36
21158FIL.....	G75	369PLP-12M-6G.....	F56	68LF-8M-6G .....	F56	CA 2x10-2.....	M36
21159FIL.....	G75	369PLP-12M-8G.....	F56	68LF-8M-8G .....	F56	CA 2x10-3.....	M36
21186FIL.....	G69	369PLP-3M-M3 .....	F56	68PLP-5/32-0 .....	K3	CA 2x10-4.....	M36
21187FIL.....	G69	369PLP-3M-M5 .....	F56	8010FIL.....	G29, G83	CA 2x2-1.....	M36
21188FIL.....	G69	369PLP-4M-2G.....	F56	80-2801R.....	E119	CA 2x2-2.....	M36
21189FIL.....	G69	369PLP-4M-4G.....	F56	84457B .....	G136	CA 2x2-3.....	M36
21196FIL.....	G63	369PLP-4M-M3 .....	F56	84480B .....	G136	CA 2x2-4.....	M36
21197FIL.....	G63	369PLP-4M-M5 .....	F56	84481B .....	G136	CA 2x4-1.....	M36
21198FIL.....	G63	369PLP-6M-2G.....	F56	84482B .....	G136	CA 2x4-2.....	M36
21199FIL.....	G63	369PLP-6M-4G.....	F56	84483B .....	G136	CA 2x4-3.....	M36
21200FIL.....	G63	369PLP-6M-6G.....	F56	84484B .....	G136	CA 2x4-4.....	M36
21201FIL.....	G63, G69	369PLP-6M-8G.....	F56	87752A .....	G135	CA 2x6-1.....	M36
21202FIL.....	G63, G69, G75	369PLP-6M-M5 .....	F56	87753A .....	G135	CA 2x6-2.....	M36
21203FIL.....	G63, G69, G75	369PLP-8M-2G.....	F56	87754A .....	G135	CA 2x6-3.....	M36
21204FIL.....	G63, G69, G75	369PLP-8M-4G.....	F56	87755A .....	G135	CA 2x6-4.....	M36
21205FIL.....	G63, G69, G75	369PLP-8M-6G.....	F56	87756A .....	G135	CA 2x8-1.....	M36
21210FIL.....	G97	369PLP-8M-8G.....	F56	87757A .....	G135	CA 2x8-2.....	M36
21211FIL.....	G97	4010FIL.....	G29, G83, G86	8872FIL.....	G89	CA 2x8-3.....	M36
21213FIL.....	G97	40-2801R.....	E119	9129609AS .....	G129	CA 2x8-4.....	M36
21214FIL.....	G97	45300-102 .....	E143, E160	9129610AS .....	G129	CA 3x12-1.....	M36
21215FIL.....	G97	45310-102 .....	E143, E160	9129611AS .....	G129	CA 3x12-2.....	M36
21216FIL.....	G97	4MA ACVB.....	B62	A 2x10.....	M41	CA 3x12-3.....	M36
21217FIL.....	G97	4MA LPSO.....	B72	A 2x2.....	M41	CA 3x12-4.....	M36
21218FIL.....	G97	4MA/4ML Series.....	B2, B18, B92	A 2x4.....	M41	CA 3x5-1.....	M36
21235FIL.....	G97	4TK Series.....	K6	A 2x6.....	M41	CA 3x5-2.....	M36
21240x.....	G97	5010FIL.....	G29, G83, G86	A 2x8.....	M41	CA 3x5-3.....	M36
21241x.....	G97	50-2801R.....	E119	A 3x12.....	M41	CA 3x5-4.....	M36
21257FIL.....	G75	6010FIL.....	G29, G83	A 3x5.....	M41	CA 3x8-1.....	M36
21260FIL.....	G75	63-2801R.....	E119	A 3x8.....	M41	CA 3x8-2.....	M36
21290FIL.....	G69	63504A .....	G135	Air Reservoirs .....	C29	CA 3x8-3.....	M36
21342BFIL .....	G78	63505A .....	G135	B671 Series.....	H38	CA 3x8-4.....	M36
21342LFIL.....	G78	63506A .....	G135	B732904 .....	H40	CA 4x16-3.....	M39
21342RFIL .....	G78	63507A .....	G135	B732905 .....	H40	CA 4x16-5.....	M39
21343FIL.....	G78	68GC-2-0.....	K3	B732906 .....	H40	CA 4x16-7.....	M39
21344FIL.....	G78	68GC-3-0.....	K3	B732907 .....	H40	CA 4x6-3.....	M39
21346FIL.....	G78	68GC-4-0.....	K3	B8785 .....	E143, E160	CA 4x6-5.....	M39
250-0111 .....	M45	68LF-10M-4G .....	F56	B8786 .....	E143, E160	CA 4x6-7.....	M39
250-0112 .....	M45	68LF-10M-6G .....	F56	B8830-N .....	L30	CA 4x8-3.....	M39
250-0113 .....	M45	68LF-10M-8G .....	F56	B8830-P .....	L30	CA 4x8-5.....	M39

Application  
Fax Forms

Part Number  
Index

Safety  
Guide

Offer of  
Sale

Application Fax Forms,  
Part Number Index, Safety  
Guide, Offer of Sale

**N**



For inventory, lead time, and kit lookup, visit [www.pdnplu.com](http://www.pdnplu.com)

Model No.	Section / Page No.	Model No.	Section / Page No.	Model No.	Section / Page No.	Model No.	Section / Page No.
CA 4x8-7.....	M39	FDC25HP.....	G134	L067680000.....	C66	L071310500.....	C47
CB032P1D01.....	B132	FDC25HP-00010000.....	G135	L067690000.....	C66	L071310600.....	C47
CB032P1D05.....	B132	FDC25HP-00020000.....	G135	L067700000.....	C66	L071310700.....	C47
CB040P1D01.....	B132	FDC35HP.....	G134	L067710000.....	C66	L071320025.....	C32
CB040P1D05.....	B132	FDC35HP-00010000.....	G135	L067720000.....	C66	L071320100.....	C32
CB050P1D01.....	B132	FDC35HP-00020000.....	G135	L067730000.....	C66	L071320200.....	C32
CB050P1D05.....	B132	FDC45HP.....	G134	L067740000.....	C66	L071320250.....	C47
CB063P1D01.....	B132	FDC45HP-00010000.....	G135	L067750000.....	C66	L071320300.....	C32
CB063P1D05.....	B132	FDC45HP-00020000.....	G135	L067760000.....	C66	L071320350.....	C47
CB080P1D01.....	B132	FR-10PRN.....	L16	L067770000.....	C66	L071320400.....	C32
CB080P1D05.....	B132	FR-1PRN.....	L16	L067780000.....	C66	L071320450.....	C47
CB100P1D01.....	B132	FR-20PRN.....	L16	L067790000.....	C66	L071320500.....	C32
CB100P1D05.....	B132	FR-30PRN.....	L16	L067800000.....	C66	L071320550.....	C47
CB125P1D01.....	B132	FR-3PRN.....	L16	L067810000.....	C66	L071320600.....	C32
CB125P1D05.....	B132	G2MNR2005.....	B103	L067820000.....	C66	L073790016.....	C33
CLS-1.....	L26	GDL.....	G130	L067830000.....	C66	L073790023.....	C33
CLS-4.....	L26	HB Series.....	E72	L067840000.....	C66	L073790024.....	C33
CRN150.....	H20	HP Series.....	H42	L067850000.....	C66	L073790028.....	C33
CRN300.....	H20	KC3104.....	G92	L067860000.....	C66	L073790032.....	C33
CRN50.....	H20	KC3104.....	L12	L067870000.....	C66	L073790040.....	C33
CRN800.....	H20	KL3333.....	G92	L067880000.....	C66	L073790048.....	C33
ELKA-K308PUR014... E143, E160		KL3333.....	L12	L067890000.....	C66	L073790056.....	C47
EM12.....	B70	KS05LPL251.....	D13, D18	L067900000.....	C66	L073790102.....	C33
EM25.....	B70	KS05LPL255.....	D13, D18	L067910000.....	C66	L073790108.....	C47
EM37.....	B70	KS07LPL311.....	D13, D18	L067920000.....	C66	L073790116.....	C47
EPS-6.....	H37	KS07LPL315.....	D13, D18	L067930000.....	C66	L073790124.....	C33
EPS-6.....	L26	KS12LPL501.....	D13, D18	L067940000.....	C66	L073790125.....	C47
EPS-7.....	H37	KS12LPL505.....	D13, D18	L067950000.....	C66	L073790132.....	C33
EPS-7.....	L26	KS15LPL621.....	D13, D18	L067960000.....	C66	L073790140.....	C33, C47
F672 Series.....	H38	KS15LPL625.....	D13, D18	L067970000.....	C66	L073800200.....	C33
FCC731-10M-4G.....	F56	KS20LPL751.....	D13, D18	L067980000.....	C66	L073800400.....	C33
FCC731-10M-6G.....	F56	KS20LPL755.....	D13, D18	L067990000.....	C66	L073800500.....	C33
FCC731-12M-6G.....	F56	KS25LPL751.....	D13, D18	L069190000.....	C65	L073800600.....	C33
FCC731-12M-8G.....	F56	KS25LPL755.....	D13, D18	L069200000.....	C65	L073800800.....	C33
FCM731-3M-M3.....	F56	KS30LPL871.....	D13, D18	L069210000.....	C65	L073800900.....	C33
FCM731-3M-M5.....	F56	KS30LPL875.....	D13, D18	L069220000.....	C65	L073801000.....	C47
FCM731-4-0.....	K3	KS40LPL101.....	D13, D18	L069230000.....	C65	L073801100.....	C33
FCM731-4-2.....	K3	KS40LPL105.....	D13, D18	L069240000.....	C65	L073801200.....	C33, C47
FCM731-4M-2G.....	F56	KY1139.....	B130	L069250000.....	C65	L073801300.....	C47
FCM731-4M-M3.....	F56	KY3240.....	G92	L069260000.....	C65	L073801400.....	C33, C47
FCM731-4M-M5.....	F56	KY3240.....	L12	L06998 0000.....	K3	L073801500.....	C33, C47
FCM731-6M-2G.....	F56	KY3241.....	G92	L071300025.....	C32	L073810008.....	D18
FCM731-6M-4G.....	F56	KY3241.....	L12	L071300100.....	C32	L073810010.....	D18
FCM731-6M-M5.....	F56	KZ2364.....	L23	L071300200.....	C32	L073810020.....	D18
FCM731-8M-2G.....	F56	KZ8255.....	L23	L071300300.....	C32	L073810024.....	D18
FCM731-8M-4G.....	F56	L067300000.....	C65	L071300350.....	C47	L073810032.....	D18
FCM731-8M-6G.....	F56	L067310000.....	C65	L071300400.....	C32, C47	L073810040.....	D18
FDC12HP.....	G134	L067320000.....	C65	L071300500.....	C32	L073810048.....	D18
FDC15HP.....	G134	L067330000.....	C65	L071300550.....	C47	L073820012.....	D18
FDC15HP-00010000.....	G135	L067340000.....	C65	L071300600.....	C32, C47	L073820024.....	D18
FDC15HP-00020000.....	G135	L067350000.....	C65	L071310100.....	C32	L073820040.....	D18
FDC20HP.....	G134	L067360000.....	C65	L071310200.....	C32	L073830012.....	D18
FDC20HP-00010000.....	G135	L067370000.....	C65	L071310300.....	C32	L073830024.....	D18
FDC20HP-00020000.....	G135	L067380000.....	C65	L071310400.....	C47	L073830040.....	D18

Application Fax Forms  
Part Number Index  
Safety Guide  
Offer of Sale  
Application Fax Forms, Part Number Index, Safety Guide, Offer of Sale



For inventory, lead times, and kit lookup, visit [www.pdnplu.com](http://www.pdnplu.com)

Model No.	Section / Page No.	Model No.	Section / Page No.	Model No.	Section / Page No.	Model No.	Section / Page No.
L073840016.....	D18	L07700000C.....	L2	L079700325.....	B34, B82	L080180063.....	G109
L073840020.....	D18	L077010000.....	L2, L14	L079700400.....	B34, B82	L080190016.....	G109
L073840024.....	D18	L07701000C.....	L2	L079700500.....	B34, B82	L080190020.....	G109
L074730056.....	E122, E143, E147, E160	L077020000.....	L2, L14	L079710150.....	B34, B82	L080190025.....	G109
L074730075.....	E122, E143, E147, E160	L07702000C.....	L2	L079710200.....	B34, B82	L080190032.....	G109
L074730106.....	E122, E143, 147, E160	L077030000.....	L4, L14	L079710250.....	B34, B82	LP/LPM Series .....	D10
L074730150.....	E122, E143, E147, E160	L07703000C.....	L4	L079710325.....	B34, B82	MA 150 .....	M24
L075370032.....	K10	L077040000.....	L4, L14	L079710400.....	B34, B82	MA 225 .....	M24
L075370040.....	K10	L07704000C.....	L4	L079710500.....	B34, B82	MA 3325 .....	M29
L075370063.....	K10	L077050000.....	L4, L14	L079720150.....	B34, B82	MA 3350 .....	M29
L075370100.....	K10	L07705000C.....	L4	L079720200.....	B34, B82	MA 35 .....	M24
L075370125.....	K10	L077060000.....	L4, L14	L079720250.....	B34, B82	MA 3625 .....	M29
L075370160.....	B123	L07706000C.....	L4	L079720325.....	B34, B82	MA 3650 .....	M29
L075370200.....	B123	L077130100.....	C32	L079720400.....	B34, B82	MA 4525 .....	M29
L075380160.....	B123	L077130200.....	C32, C37	L079730150.....	B34, B82	MA 4550 .....	M29
L075380200.....	B123	L077130300.....	C32, C37	L079730200.....	B34, B82	MA 4575 .....	M29
L075400032.....	B126	L077130400.....	C32, C37	L079730250.....	B34, B82	MA 600 .....	M24
L075400050.....	B126	L077130500.....	C32, C37	L079730325.....	B34, B82	MA 64100 .....	M29
L075400063.....	B126	L077150100.....	C32	L079730400.....	B34, B82	MA 64150 .....	M29
L075400125.....	B126	L077150200.....	C32, C37	L079730500.....	B34, B82	MA 6450 .....	M29
L075400160.....	B126	L077150400.....	C32, C37	L079740150.....	B34, B82	MA 900 .....	M24
L075400125.....	B126	L077150500.....	C37	L079740200.....	B34, B82	MC 10H .....	M16
L075400160.....	B126	L077160028.....	C33	L079740250.....	B34, B82	MC 10L .....	M16
L075410160.....	B125	L077160040.....	C33, C37	L079740325.....	B34, B82	MC 150 .....	M18
L075410200.....	B125	L077160048.....	C33, C37	L079740400.....	B34, B82	MC 150H .....	M18
L075420160.....	B124	L077160124.....	C33, C37	L079740500.....	B34, B82	MC 150H2 .....	M18
L075420200.....	B124	L077160132.....	C37	L079750150.....	B34, B82	MC 225 .....	M18
L075480160.....	B124	L077170500.....	C33	L079750200.....	B34, B82	MC 225H .....	M18
L075480200.....	B124	L077170800.....	C33, C37	L079750250.....	B34, B82	MC 225H2 .....	M18
L075490036.....	B129	L077170900.....	C33, C37	L079750325.....	B34, B82	MC 25.....	M16
L075540005.....	D8	L077171200.....	C33, C37	L079750400.....	B34, B82	MC 25H .....	M16
L075540006.....	D8	L077171400.....	C37	L080100025.....	G100	MC 25L.....	M16
L075540008.....	D8	L078320000.....	C41	L080100032.....	G100	MC 3325-1.....	M27
L075540010.....	D8	L078320001.....	C41	L080100040.....	G100	MC 3325-2.....	M27
L075540014.....	D8	L078320002.....	C41	L080100050.....	G100	MC 3325-3.....	M27
L075540018.....	D8	L078320003.....	C41	L080100063.....	G100	MC 3325-4.....	M27
L075540022.....	D8	L078320004.....	C41	L080160020.....	G110	MC 3350-1.....	M27
L075540026.....	D8	L078320005.....	C41	L080160025.....	G110	MC 3350-2.....	M27
L075540036.....	B130	L078320006.....	C41	L080160032.....	G110	MC 3350-3.....	M27
L076600100.....	C32	L078320007.....	C41	L080160040.....	G110	MC 3350-4.....	M27
L076600200.....	C32	L078320008.....	C41	L080160050.....	G110	MC 3625-1.....	M27
L076950000.....	L3, L14	L078320009.....	C41	L080160063.....	G110	MC 3625-2.....	M27
L07695000C.....	L3	L078350000.....	B70	L08016M020.....	G110	MC 3625-3.....	M27
L076960000.....	L3, L14	L078370000.....	B70	L08016M025.....	G110	MC 3625-4.....	M27
L07696000C.....	L3	L078380000.....	B70	L08016M032.....	G110	MC 3650-1.....	M27
L076970000.....	L3, L14	L078390000.....	B70	L08016M040.....	G110	MC 3650-2.....	M27
L07697000C.....	L3	L078400000.....	B70	L08016M050.....	G110	MC 3650-3.....	M27
L076980000.....	L3, L14	L078410000.....	B70	L08016M063.....	G110	MC 3650-4.....	M27
L07698000C.....	L3	L078930016.....	G110	L080180016.....	G109	MC 4525-1.....	M27
L076990000.....	L2, L14	L079020016.....	G100	L080180020.....	G109	MC 4525-2.....	M27
L07699000C.....	L2	L079020020.....	G100	L080180025.....	G109	MC 4525-3.....	M27
L077000000.....	L2, L14	L079700150.....	B34, B82	L080180032.....	G109	MC 4525-4.....	M27
		L079700200.....	B34, B82	L080180040.....	G109	MC 4550-1.....	M27
		L079700250.....	B34, B82	L080180050.....	G109	MC 4550-2.....	M27

**Application  
Fax Forms**  
**Part Number  
Index**  
**Safety  
Guide**  
**Offer of  
Sale**  
**Application Fax Forms,  
Part Number Index, Safety  
Guide, Offer of Sale**



For inventory, lead time, and kit lookup, visit [www.pdnplu.com](http://www.pdnplu.com)



Model No.	Section / Page No.	Model No.	Section / Page No.	Model No.	Section / Page No.	Model No.	Section / Page No.
MC 4550-3.....	M27	OSP-P KF .....	G64	P1A-S 010 .....	C51, C52	P1C-4PRC .....	B129
MC 4550-4.....	M27	OSP-P Linear Guides .....	G43	P1A-S 012 .....	C51, C52	P1C-4PRF .....	B130
MC 4575-1.....	M27	OSP-P POWERSLIDE .....	G50	P1A-S 016 .....	C51, C52	P1C-4PRS .....	B129
MC 4575-2.....	M27	OSP-P PROLINE .....	G54	P1A-S 020 .....	C51, C52	P1C-4QMA .....	B127
MC 4575-3.....	M27	OSP-P Sensors .....	G90	P1A-S 025 .....	C51, C52	P1C-4QMBA .....	B123
MC 4575-4.....	M27	OSP-P Series .....	G2, G9	P1C-4KMA.....	B127	P1C-4QMCA .....	B126
MC 600 .....	M18	OSP-P SLIDELINE.....	G45	P1C-4KMBA .....	B123	P1C-4QMD .....	B124
MC 600H .....	M18	OSP-P Standard.....	G10	P1C-4KMCA .....	B126	P1C-4QME.....	B125
MC 600H2 .....	M18	OSP-P STARLINE.....	G59	P1C-4KMD.....	B124	P1C-4QMF.....	B123
MC 64100-1.....	M27	OSP-P10.....	G16	P1C-4KME.....	B125	P1C-4QMSA .....	B124
MC 64100-2.....	M27	OSP-P16.....	G17	P1C-4KMF.....	B123	P1C-4QMT.....	B125
MC 64100-3.....	M27	OSP-P25.....	G17	P1C-4KMSA.....	B124	P1C-4RMA.....	B127
MC 64100-4.....	M27	OSP-P32.....	G17	P1C-4KMT .....	B125	P1C-4RMB.....	B123
MC 64150-1.....	M27	OSP-P40.....	G17	P1C-4KRC .....	B129	P1C-4RMCA .....	B126
MC 64150-2.....	M27	OSP-P50.....	G17	P1C-4KRF.....	B130	P1C-4RMD.....	B124
MC 64150-3.....	M27	OSP-P63.....	G17	P1C-4KRS .....	B129	P1C-4RME.....	B125
MC 64150-4.....	M27	OSP-P80.....	G17	P1C-4LMA .....	B127	P1C-4RMF .....	B123
MC 6450-1.....	M27	P Series.....	C58	P1C-4LMBA.....	B123	P1C-4RMSA .....	B124
MC 6450-2.....	M27	P1A.....	C50	P1C-4LMCA.....	B126	P1C-4RMT .....	B125
MC 6450-3.....	M27	P1A-2CCB .....	L4	P1C-4LMD .....	B124	P1C-4RRC .....	B129
MC 6450-4.....	M27	P1A-2CCC .....	L2, L3, L13	P1C-4LME .....	B125	P1C-4RRF.....	B130
MC 75-1.....	M16	P1A-2DCB .....	L4	P1C-4LMF.....	B123	P1C-4RRS .....	B129
MC 75-2.....	M16	P1A-2DCC .....	L2, L3, L13	P1C-4LMSA.....	B124	P1C-4SRS .....	B129
MC 75-3.....	M16	P1A-2FCB .....	L4	P1C-4LMT .....	B125	P1D Series .....	B104
MC 9-1.....	M16	P1A-2FCC.....	L2, L3, L13	P1C-4LRC.....	B129	P1D-4KMYF .....	B128
MC 9-2.....	M16	P1A-2HCB .....	L4	P1C-4LRF .....	B130	P1D-4LMYF .....	B128
MC150M-B .....	G63, G69, G75	P1A-2HCC .....	L2, L3, L13	P1C-4LRS.....	B129	P1D-4MMYF .....	B128
MC150MH .....	G129	P1A-2JCB .....	L4	P1C-4MMA .....	B127	P1D-4NMYF .....	B128
MC150MH-B.....	G63, G69, G75	P1A-2JCC.....	L2, L3, L13	P1C-4MMBA.....	B123	P1D-4PMYF .....	B128
MC225M .....	G63, G69, G75	P1A-2XEK.....	L13	P1C-4MMCA.....	B126	P1D-4QMYF.....	B128
MC225MH .....	G63, G69, G75	P1A-2XLK .....	L3, L13	P1C-4MMD .....	B124	P1E-6KB0 .....	B127
MC25M.....	G63, G69	P1A-2XMK .....	L2, L13	P1C-4MME .....	B125	P1E-6LB0 .....	B127
MC25MH .....	G63, G69	P1A-2XRL .....	L4	P1C-4MMF .....	B123	P1E-6MB0 .....	B127
MC25MH-NB .....	G129	P1A-2XSH.....	L4	P1C-4MMSA.....	B124	P1E-6NB0.....	B127
MC600M .....	G63, G69, G75	P1A-4CMB.....	C56	P1C-4MMT .....	B125	P1E-6PB0 .....	B127
MC600MH .....	G63, G69, G75	P1A-4CMF .....	C56	P1C-4MRC .....	B129	P1E-6QB0.....	B127
MC75M-1.....	G63, G69, G75	P1A-4CMJ .....	C56	P1C-4MRF .....	B130	P1M-4DRC.....	D9
MC75M-2.....	G63, G69, G75	P1A-4CMT .....	C57	P1C-4MRS.....	B129	P1M-4DRE.....	D9
ML 3325.....	M29	P1A-4CRC .....	C57	P1C-4NMA.....	B127	P1M-4FRC .....	D9
ML 3350.....	M29	P1A-4CRS .....	C57	P1C-4NMBA .....	B123	P1M-4FRE .....	D9
ML 3625.....	M29	P1A-4DMB.....	C56	P1C-4NMCA.....	B126	P1M-4HRC .....	D9
ML 3650.....	M29	P1A-4DMF .....	C56	P1C-4NMD .....	B124	P1M-4HRE.....	D9
ML 4525.....	M29	P1A-4DMJ .....	C56	P1C-4NME.....	B125	P1M-4JRC .....	D9
ML 4550.....	M29	P1A-4DMT .....	C57	P1C-4NMF .....	B123	P1M-4JRE.....	D9
ML 6425.....	M29	P1A-4DRC .....	C57	P1C-4NMSA .....	B124	P1M-4LRC .....	D9
ML 645.....	M29	P1A-4DRS.....	C57	P1C-4NMT .....	B125	P1M-4LRE .....	D9
NK04.....	E136, E154	P1A-4HMB.....	C56	P1C-4PMA.....	B127	P1M-4MRC .....	D9
NK06.....	E136, E154	P1A-4HMF .....	C56	P1C-4PMBA .....	B123	P1M-4MRE .....	D9
NK08.....	E136, E154	P1A-4HMJ .....	C56	P1C-4PMCA .....	B126	P1M-4PRC.....	D9
NK12.....	E136, E154	P1A-4HMT .....	C57	P1C-4PMD.....	B124	P1M-4PRE .....	D9
OSP-P Active Brake .....	G22	P1A-4HRC .....	C57	P1C-4PME .....	B125	P1Q-4DMB .....	D7
OSP-P Bi-Parting .....	G40	P1A-4HRS .....	C57	P1C-4PMF .....	B123	P1Q-4DMF.....	D7
OSP-P Clean Room .....	G36	P1A-4JRC .....	C57	P1C-4PMSA.....	B124	P1Q-4DMT.....	D8
OSP-P HD.....	G71	P1A-4JRS .....	C57	P1C-4PMT .....	B125	P1Q-4FMB.....	D7

Application Fax Forms	Part Number Index	Safety Guide	Offer of Sale	Application Fax Forms, Part Number Index, Safety Guide, Offer of Sale
-----------------------	-------------------	--------------	---------------	---



For inventory, lead times, and kit lookup, visit [www.pdnplu.com](http://www.pdnplu.com)



Model No.	Section / Page No.	Model No.	Section / Page No.	Model No.	Section / Page No.	Model No.	Section / Page No.
P1Q-4FMF	D7	P1QS032DC7N0075	D2	P1V-6/312694	J70	P1V-S008A0700	J19
P1Q-4FMT	D8	P1QS032DC7N0100	D2	P1V-6/312695	J70	P1V-S008A0Q00	J19
P1Q-4HMB	D7	P1QS040DC7N0015	D2	P1V-6/3131179A	J63, J64, J65, J70	P1V-S008N0***	J59
P1Q-4HMF	D7	P1QS040DC7N0025	D2	P1V-6/314407	J60	P1V-S008N0130	J60
P1Q-4HMT	D8	P1QS040DC7N0030	D2	P1V-6/314693	J60	P1V-S008N0190	J60
P1Q-4JMB	D7	P1QS040DC7N0040	D2	P1V-6/314694	J60	P1V-S008N0600	J60
P1Q-4JMF	D7	P1QS040DC7N0050	D2	P1V-6/388378A	J63, J64, J65, J70	P1V-S008N0N00	J60
P1Q-4JMT	D8	P1QS040DC7N0075	D2	P1V-6/4405021B	J72	P1V-S009	J72
P1Q-4KMB	D7	P1QS040DC7N0100	D2	P1V-6/4405021C	J72	P1V-S009N0A000	J59, J68
P1Q-4KMF	D7	P1QS050DC7N0015	D2	P1V-6/4405021D	J72	P1V-S012	J13, J14, J21, J49
P1Q-4KMT	D8	P1QS050DC7N0025	D2	P1V-6/4447861B	J50	P1V-S012•0010	J20
P1Q-4LMB	D7	P1QS050DC7N0030	D2	P1V-6/4447861C	J50	P1V-S012•0060	J20
P1Q-4LMF	D7	P1QS050DC7N0040	D2	P1V-6/4447861D	J50	P1V-S012•0090	J20
P1Q-4LMT	D8	P1QS050DC7N0050	D2	P1V-6/4447871E	J50	P1V-S012•0140	J20
P1Q-4MMB	D7	P1QS050DC7N0075	D2	P1V-6/4449191C	J50	P1V-S012•0360	J20
P1Q-4MMF	D7	P1QS050DC7N0100	D2	P1V-6/4449191D	J50	P1V-S012•0550	J20
P1Q-4MMT	D8	P1QS063DC7N0015	D2	P1V-6/4449191A	J50	P1V-S012•0N00	J20
P1Q-4NMB	D7	P1QS063DC7N0025	D2	P1V-6/4449191B	J50	P1V-S012A	J15
P1Q-4NMF	D7	P1QS063DC7N0030	D2	P1V-6/4449211A	J72	P1V-S012D	J15
P1Q-4NMT	D8	P1QS063DC7N0040	D2	P1V-6/4449221A	J72	P1V-S015	J72
P1Q-4PMB	D7	P1QS063DC7N0050	D2	P1V-6/446083A	J50	P1V-S015N0AQ0	J59, J69
P1Q-4PMF	D7	P1QS063DC7N0075	D2	P1V-6/446084A	J50	P1V-S017	J72
P1Q-4PMT	D8	P1QS080DC7N0015	D2	P1V-6/446085A	J72	P1V-S017M0***	J59
P1Q-4QMB	D7	P1QS080DC7N0025	D2	P1V-6/446086A	J72	P1V-S017M0066	J62
P1Q-4QMF	D7	P1QS080DC7N0030	D2	P1V-6/446087A	J72	P1V-S017M0100	J62
P1Q-4QMT	D8	P1QS080DC7N0040	D2	P1V-6/446088A	J72	P1V-S017M0150	J62
P1QS012DC7G0005	D2	P1QS080DC7N0050	D2	P1V-6/4460961B	J51	P1V-S017M0400	J62
P1QS012DC7G0010	D2	P1QS100DC7N0015	D2	P1V-6/446096A	J51	P1V-S017M0600	J62
P1QS012DC7G0015	D2	P1QS100DC7N0025	D2	P1V-6/804650	J64, J65	P1V-S017N0***	J59
P1QS012DC7G0025	D2	P1QS100DC7N0030	D2	P1V-6/804652	J66	P1V-S017N0066	J61
P1QS012DC7G0030	D2	P1QS100DC7N0040	D2	P1V-6/804655	J62	P1V-S017N0100	J61
P1QS016DC7G0005	D2	P1QS100DC7N0050	D2	P1V-6/804661	J64, J65	P1V-S017N0150	J61
P1QS016DC7G0010	D2	P1QS100DC7N0075	D2	P1V-6/804663	J66	P1V-S017N0400	J61
P1QS016DC7G0015	D2	P1S-4JRD	B129	P1V-6/806110	J63, J64, J65, J70	P1V-S017N0600	J61
P1QS016DC7G0025	D2	P1S-4JRT	B129	P1V-6/806112	J61, J62	P1V-S017N0Q00	J61
P1QS016DC7G0030	D2	P1S-4LRD	B129	P1V-6/823221	J61, J62	P1V-S020	J13, J14, J23, J33, J35, J49
P1QS020DC7G0010	D2	P1S-4LRT	B129	P1V-S Air Tools	J57	P1V-S020•0005	J22
P1QS020DC7G0015	D2	P1S-4MRD	B129	P1V-S Ordering	J16	P1V-S020•0018	J22
P1QS020DC7G0025	D2	P1S-4MRT	B129	P1V-S Series	J1	P1V-S020•0032	J22
P1QS020DC7G0030	D2	P1S-4PRD	B129	P1V-S002	J14, J17, J49	P1V-S020•0070	J22
P1QS020DC7G0040	D2	P1S-4PRT	B129	P1V-S002A	J13, J15	P1V-S020•0140	J22
P1QS020DC7G0050	D2	P1S-4RRD	B129	P1V-S002A0095	J17	P1V-S020•0240	J22
P1QS025DC7G0010	D2	P1V-6/302923A	J61, J62	P1V-S002A0130	J17	P1V-S020•0460	J22
P1QS025DC7G0015	D2	P1V-6/312681	J61, J63	P1V-S003	J14, J49	P1V-S020•0E50	J22
P1QS025DC7G0025	D2	P1V-6/312682	J61, J63	P1V-S003A	J13	P1V-S020A	J15
P1QS025DC7G0030	D2	P1V-6/312684	J61, J63	P1V-S003B	J15	P1V-S020A00005	J22
P1QS025DC7G0040	D2	P1V-6/312686	J61, J63	P1V-S003B0100	J18	P1V-S020A0001	J22
P1QS025DC7G0050	D2	P1V-6/312689	J61, J63, J64	P1V-S008	J14, J19, J49, J72	P1V-S020A0002	J22
P1QS032DC7N0010	D2	P1V-6/312690	J70	P1V-S008A	J13, J15	P1V-S020AD001	J34
P1QS032DC7N0015	D2	P1V-6/312691	J70	P1V-S008A0130	J19	P1V-S020AD002	J34
P1QS032DC7N0025	D2	P1V-6/312692	J70	P1V-S008A0190	J19	P1V-S020AD005	J34
P1QS032DC7N0030	D2	P1V-6/312693	J70			P1V-S020AD018	J34
P1QS032DC7N0040	D2					P1V-S020AD032	J34
P1QS032DC7N0050	D2						

Application  
Fax Forms

Part Number  
Index

Safety  
Guide

Offer of  
Sale

Application Fax Forms,  
Part Number Index, Safety  
Guide, Offer of Sale

**N**



For inventory, lead time, and kit lookup, visit [www.pdnplu.com](http://www.pdnplu.com)

Model No.	Section / Page No.	Model No.	Section / Page No.	Model No.	Section / Page No.	Model No.	Section / Page No.
P1V-S020AD070	J34	P1V-S030AD460	J36	P1V-S090A0C00	J28	P5GB	F3, F6
P1V-S020AD140	J34	P1V-S030ADE50	J36	P1V-S100NOF30	J59, J71	P5GB-012MSG006B	F6
P1V-S020AD240	J34	P1V-S030D	J15	P1V-S120	J14, J31, J33, J39, J49	P5GB-016MSG008B	F6
P1V-S020AD460	J34	P1V-S030N0***	J59	P1V-S120A	J13, J15	P5GB-020MSG012B	F6
P1V-S020ADE50	J34	P1V-S030N0AN0	J69	P1V-S120A0020	J30	P5GB-025MSG014B	F6
P1V-S020D	J15	P1V-S030N0X00	J69	P1V-S120A0032	J30	P5GB-032MSG016B	F6
P1V-S025	J72	P1V-S040	J72	P1V-S120A0070	J30	P5GM	F3, F19
P1V-S025M0***	J59	P1V-S040M0***	J59	P1V-S120A0110	J30	P5GM-010	F21
P1V-S025M0035	J64	P1V-S040M0140	J65	P1V-S120A0250	J30	P5GM-010MSG005B	F19
P1V-S025M0070	J64	P1V-S040M0250	J65	P1V-S120A0900	J30	P5GM-010MSG006B	F19
P1V-S025M0140	J64	P1V-S040M0480	J65	P1V-S120AD032	J38	P5GM-010MSG010B	F19
P1V-S025M0250	J64	P1V-S040M0H00	J65	P1V-S120AD070	J38	P5GM-014	F21
P1V-S025M0480	J64	P1V-S040N0L00	J59, J70	P1V-S120AD110	J38	P5GM-014MSG006B	F19
P1V-S025M0H00	J64	P1V-S050	J72	P1V-S120AD250	J38	P5GM-014MSG010B	F19
P1V-S025N0***	J59	P1V-S050N0L00	J59, J71	P1V-S120AD900	J38	P5GM-014MSG013B	F19
P1V-S025N0035	J63	P1V-S057	J41, J45, J49	P1V-S4002B	J17, J18, J48	P5GM-022	F21
P1V-S025N0070	J63	P1V-S057A	J15	P1V-S4008B	J19, J48, J67	P5GM-022MSG010B	F19
P1V-S025N0140	J63	P1V-S057A0004	J44	P1V-S4008F	J19, J48, J67	P5GM-022MSG013B	F19
P1V-S025N0250	J63	P1V-S057A0007	J44	P1V-S4012B	J21, J48	P5GM-022MSG019B	F19
P1V-S025N0480	J63	P1V-S057A0011	J44	P1V-S4012F	J21, J48	P5GM-032	F21
P1V-S025N0H00	J63	P1V-S057A0015	J44	P1V-S4020B	J23, J35, J48, J67	P5GM-032MSG013B	F19
P1V-S025N0Z00	J59, J69	P1V-S060	J14, J27, J49, J72	P1V-S4020C	J25, J37, J48	P5GM-032MSG019B	F19
P1V-S028	J41, J43, J49	P1V-S060A	J13, J15	P1V-S4020F	J23, J35, J48, J67	P5GM-032MSG032B	F19
P1V-S028A	J15	P1V-S060A0015	J26	P1V-S4028B1	J48	P5GN	F3, F16
P1V-S028A0002	J42	P1V-S060A0030	J26	P1V-S4028B1 & B2	J43, J45, J47	P5GN-012	F18
P1V-S028A0003	J42	P1V-S060A0048	J26	P1V-S4028B2	J48	P5GN-012MSG001B	F16
P1V-S028A0005	J42	P1V-S060A0063	J26	P1V-S4028F1	J48	P5GN-012MSG002B	F16
P1V-S028A0008	J42	P1V-S060A0170	J26	P1V-S4028F1 & F2	J43, J45, J47	P5GN-012MSG003B	F16
P1V-S028A0017	J42	P1V-S060A0270	J26	P1V-S4028F2	J48	P5GN-014	F18
P1V-S028B1	J43, J45, J47	P1V-S060A0350	J26	P1V-S4030B	J25, J37, J48, J67	P5GN-014MSG002B	F16
P1V-S028B2	J43, J45, J47	P1V-S060A0E00	J26	P1V-S4030F	J25, J37, J48, J67	P5GN-014MSG003B	F16
P1V-S028F1	J43, J45, J47	P1V-S060M0015	J59, J66	P1V-S4060B	J27, J29, J48, J67	P5GN-014MSG005B	F16
P1V-S028F2	J43, J45, J47	P1V-S060M0030	J59, J66	P1V-S4060F	J27, J29, J48, J67	P5GN-022	F18
P1V-S030	J13, J14, J25, J33, J37, J49, J72	P1V-S060M0048	J59, J66	P1V-S4120B	J31, J39, J48	P5GN-022MSG003B	F16
P1V-S030•0005	J24	P1V-S060M0063	J59, J66	P1V-S4120F	J31, J39, J48	P5GN-022MSG005B	F16
P1V-S030•0018	J24	P1V-S060M0170	J59, J66	P1X	G98	P5GN-022MSG006B	F16
P1V-S030•0034	J24	P1V-S060M0270	J59, J66	P1Z	G116	P5GN-032	F18
P1V-S030•0060	J24	P1V-S060M0350	J59, J66	P1ZM016GNN-R	G129	P5GN-032MSG005B	F16
P1V-S030•0140	J24	P1V-S070	J72	P1ZM016SAN-R	G129	P5GN-032MSG006B	F16
P1V-S030•0240	J24	P1V-S070N0N00	J59, J71	P1ZM016SNN-R	G129	P5GN-032MSG010B	F16
P1V-S030•0460	J24	P1V-S086	J41, J49	P1ZM020GNN-R	G129	P5GP	F3, F28
P1V-S030•0E50	J24	P1V-S086A	J15	P1ZM020SAN-R	G129	P5GP-000ESX025B	F28
P1V-S030A	J15	P1V-S086A0004	J46	P1ZM032GNN-R	G129	P5GQ	F3, F30
P1V-S030A0010	J24, J25	P1V-S086A0007	J46	P1ZM032SAN-R	G129	P5GQ-000QXS010B	F30
P1V-S030A0023	J24, J25	P1V-S086A0011	J46	P5E Series	E104	P5GQ-000QXS020B	F30
P1V-S030AD005	J36	P1V-S086A0015	J46	P5GA	F3, F4	P5GQ-000RSX010B	F30
P1V-S030AD010	J36, J37	P1V-S090	J14, J29, J49	P5GA-012MSG030B	F4	P5GQ-000RSX020B	F30
P1V-S030AD018	J36	P1V-S090A	J13, J15	P5GA-016MSG030B	F4	P5GR	F3, F10
P1V-S030AD023	J36, J37	P1V-S090A0030	J28	P5GA-020MSG030B	F4	P5GR-010	F12
P1V-S030AD034	J36	P1V-S090A0048	J28	P5GA-025MSG030B	F4	P5GR-010DSG006B	F10
P1V-S030AD060	J36	P1V-S090A0063	J28	P5GA-032MSG030B	F4	P5GR-010DSG013B	F10
P1V-S030AD140	J36	P1V-S090A0170	J28			P5GR-010MSG006B	F10
P1V-S030AD240	J36	P1V-S090A0270	J28			P5GR-010MSG013B	F10
		P1V-S090A0350	J28			P5GR-014	F12

Application Fax Forms  
Part Number Index  
Safety Guide  
Offer of Sale  
Application Fax Forms, Part Number Index, Safety Guide, Offer of Sale



For inventory, lead times, and kit lookup, visit [www.pdnplu.com](http://www.pdnplu.com)

Model No.	Section / Page No.	Model No.	Section / Page No.	Model No.	Section / Page No.	Model No.	Section / Page No.
P5GR-014DSG016B.....	F10	P5GW-032.....	F35	P5SS-006.....	F38	P8S-GEFRX.....	L12
P5GR-014DSG025B.....	F10	P5GW-032DSG004B.....	F32	P5SS-006-EA-.....	F46	P8S-GEFRX1.....	G88, G89
P5GR-014MSG016B.....	F10	P5GW-032MFG004B.....	F32	P5SS-006-RA-.....	F46	P8S-GNCHX.....	G88, G89
P5GR-014MSG025B.....	F10	P5GW-032MSG004B.....	F32	P5SS-008.....	F38	P8S-GNCHX.....	L3, L5, L12
P5GR-021.....	F12	P5GW-043.....	F35	P5SS-008-EA-.....	F46	P8S-GNCHX.....	G89
P5GR-021DSG025B.....	F10	P5GW-043DSG006B.....	F32	P5SS-008-ESK.....	F47	P8S-GNFAX.....	L3, L5
P5GR-021DSG038B.....	F10	P5GW-043MFG006B.....	F32	P5SS-008-RA-.....	F46	P8S-GNFDX.....	L3, L5
P5GR-021MSG025B.....	F10	P5GW-043MSG006B.....	F32	P5SS-008-RSK.....	F47	P8S-GNMHX.....	L3, L5
P5GR-021MSG038B.....	F10	P5GW-055.....	F35	P5SS-012.....	F38	P8S-GNSCX.....	L3, L5
P5GS.....	F3, F22	P5GW-055DSG008B.....	F32	P5SS-012-EA-.....	F46	P8S-GPCHX.....	G88, G89, G92
P5GS-016MSG019B.....	F22, F24	P5GW-055MFG008B.....	F32	P5SS-012-ESK.....	F47	P8S-GPCHX.....	L2, L5, L12
P5GS-016MSG032B.....	F22, F24	P5GW-055MSG008B.....	F32	P5SS-012-RA-.....	F46	P8S-GPFAX.....	G92
P5GS-024MSG025B.....	F22, F24	P5GW-072.....	F35	P5SS-012-RSK.....	F47	P8S-GPFAX.....	L2, L5, L12
P5GS-024MSG051B.....	F22, F24	P5GW-072DSG010B.....	F32	P5SS-016.....	F38	P8S-GPFDX.....	G92
P5GS-032MSG038B.....	F22, F24	P5GW-072MFG010B.....	F32	P5SS-016-EA-.....	F46	P8S-GPFDX.....	L2, L5, L12
P5GS-032MSG074B.....	F22, F24	P5GW-072MSG010B.....	F32	P5SS-016-ESK.....	F47	P8S-GPFLX/EX.....	L5
P5GT.....	F3, F25	P5GW-095.....	F35	P5SS-016-RA-.....	F46	P8S-GPFTX.....	L2
P5GT-025.....	F27	P5GW-095DSG013B.....	F32	P5SS-016-RSK.....	F47	P8S-GPMHX.....	L2, L5
P5GT-025MFG006B.....	F25	P5GW-095MFG013B.....	F32	P5SS-020.....	F38	P8S-GPNCSX.....	L3
P5GT-025MFG010B.....	F25	P5GW-120.....	F35	P5SS-020-EA-.....	F46	P8S-GPSCX.....	L2, L5
P5GT-025MSG006B.....	F25	P5GW-120DSG016B.....	F32	P5SS-020-ESK.....	F47	P8S-GRCHX.....	G92
P5GT-025MSG010B.....	F25	P5GW-120MFG016B.....	F32	P5SS-020-RA-.....	F46	P8S-GRCHX.....	L4, L6, L12
P5GT-032.....	F27	P5GW-120MSG016B.....	F32	P5SS-020-RSK.....	F47	P8S-GRFAX.....	G92
P5GT-032MFG013B.....	F25	P5GW-156.....	F35	P5SS-025.....	F38	P8S-GRFAX.....	L4, L6, L12
P5GT-032MSG013B.....	F25	P5GW-156DSG025B.....	F32	P5SS-025-EA-.....	F46	P8S-GRFDX.....	G92
P5GT-046.....	F27	P5GW-156MFG025B.....	F32	P5SS-025-ESK.....	F47	P8S-GRFDX.....	L4, L6, L12
P5GT-046MFG019B.....	F25	P5GW-156MSG025B.....	F32	P5SS-025-RA-.....	F46	P8S-GRFDX2.....	G88, G89
P5GT-046MSG019B.....	F25	P5GW-225.....	F35	P5SS-025-RSK.....	F47	P8S-GRFDX2.....	L6, L12
P5GT-064.....	F27	P5GW-225DSG035B.....	F32	P5T Series.....	E3	P8S-GRFLX.....	L4
P5GT-064MFG032B.....	F25	P5GW-225MFG035B.....	F32	P8S-CABL-010.....	F52	P8S-GRMHX.....	L4, L6
P5GT-064MSG032B.....	F25	P5GW-225MSG035B.....	F32	P8S-CABL-013.....	F52	P8S-GRSCX.....	L4, L6
P5GT-089.....	F27	P5L Series.....	E22	P8S-CABL-014.....	F52	P8S-HHSN-017.....	F52, F54
P5GT-089MFG051B.....	F25	P5L-B.....	E24	P8S-CABL-018.....	F52	P8S-HHSP-011.....	F52, F54
P5GT-089MSG051B.....	F25	P5L-R.....	E24	P8S-CABL-052.....	F31	P8S-HHSP-017.....	F52, F54
P5GU.....	F3, F13	P5L-T.....	E24	P8S-CABL-053.....	F31	P8S-HISN-011.....	F52, F54
P5GU-011.....	F15	P5MD.....	F50	P8S-ENFXS.....	F52, F53	P8S-HISN-014.....	F52, F55
P5GU-011MFG006B.....	F13	P5MD-014.....	F51	P8S-ENFXS.....	L3	P8S-HISN-017.....	F52, F55
P5GU-011MFG013B.....	F13	P5MD-014SSG016B.....	F50	P8S-ENSUS.....	F52, F53	P8S-HISN-019.....	F52
P5GU-011MSG006B.....	F13	P5MD-014TSG016B.....	F50	P8S-ENSUS.....	L3	P8S-HISP-011.....	F52, F54
P5GU-011MSG013B.....	F13	P5MD-020.....	F51	P8S-EPFXS.....	F52, F53	P8S-HISP-014.....	F52, F55
P5GU-013.....	F15	P5MD-020SSG025B.....	F50	P8S-EPFXS.....	L2	P8S-HISP-017.....	F52, F55
P5GU-013MFG019B.....	F13	P5MD-020TSG025B.....	F50	P8S-EPFXS.....	F52, F53	P8S-HISP-019.....	F52
P5GU-013MFG025B.....	F13	P5MD-027.....	F51	P8S-EPFXS.....	L2	P8S-HSMK-003.....	F52
P5GU-013MSG019B.....	F13	P5MD-027SSG032B.....	F50	P8S-ERFXS.....	F52, F53	P8S-HSMK-072.....	F52
P5GU-013MSG025B.....	F13	P5MD-027TSG032B.....	F50	P8S-ERFXS.....	L4	P8S-HSMK-073.....	F52
P5GV.....	F3, F8	P5RS.....	F48	P8S-ERSUS.....	F52, F53	P8S-HSMK-116.....	F52
P5GV-010MFG003B.....	F8	P5RS-016DSG190B.....	F48	P8S-ERSUS.....	L4	P8S-HSMK-117.....	F52
P5GV-010MFG005B.....	F8	P5RS-020DSG190B.....	F48	P8S-FNFXS.....	F52, F53	P8S-HSMK-118.....	F52
P5GV-010MFG006B.....	F8	P5RS-025DSG190B.....	F48	P8S-FNSUS.....	F52	P8S-HSMK-119.....	F52
P5GV-010MS.....	F9	P5RS-025DSG190WNSNNN.....	F48	P8S-FPFXS.....	F52, F53	P8S-HSMK-120.....	F52
P5GV-010MSG003B.....	F8	P5RS-032DSG190B.....	F48	P8S-FPSUS.....	F52	P8S-MNFLY.....	L7
P5GV-010MSG005B.....	F8	P5RS-032DSG190WNSNNN.....	F48	P8S-FRFXS.....	F52, F53	P8S-MNFTX.....	L7
P5GV-010MSG006B.....	F8	P5SS.....	F36	P8S-FRSUS.....	F52, F53	P8S-MNSHX.....	L7
P5GW.....	F3, F32			P8S-GEFRX.....	G92	P8S-MPFLY.....	L7

Application  
Fax Forms

Part Number  
Index

Safety  
Guide

Offer of  
Sale

Application Fax Forms,  
Part Number Index, Safety  
Guide, Offer of Sale

**N**



For inventory, lead time, and kit lookup, visit [www.pdnplu.com](http://www.pdnplu.com)

Model No.	Section / Page No.	Model No.	Section / Page No.	Model No.	Section / Page No.	Model No.	Section / Page No.
P8S-MPFTX	L7	PK2504ML05	B88	PRNA20-P	H18	PWBA38227	K5
P8S-MPSHX	L7	PK3254MA01	B36, B84	PRNA20S	H13	PWBA3833	K5
P8S-MRFLY	L8	PK3254MA05	B36, B84	PRNA3D	H13	PWBA38337	K5
P8S-MRFTX	L8	PK3254ML01	B88	PRNA3-L	H18	PWBA3888	K5
P8S-MRSHX	L8	PK3254ML05	B88	PRNA3-P	H18	PWBA38887	K5
P8S-SNETX	L3, L10	PK4004MA01	B36, B84	PRNA3S	H13	PWBA3899	K5
P8S-SNTHX	L3, L10	PK4004MA05	B36, B84	PS2028BP	B71	PWBA38997	K5
P8S-SPETXD	L2, L10	PK4004ML01	B88	PS2028JCP	B71	RG04MA0061	B36, B83
P8S-SPTHXD	L2, L10	PK4004ML05	B88	PS203279BP	B71	RG04MA0065	B36, B83
P8S-SRETX	L4, L10	PK5004MA01	B36, B84	PS203283BP	B71	RG04MA0101	B36, B83
P8S-SRTHX	L4, L10	PK5004MA05	B36, B84	PS2032J79CP	B71	RG04MA0105	B36, B83
P8S-TMA0X	L2, L3, L4	PK5004ML01	B88	PS2032J83CP	B71	RG04MA0131	B36, B83
P8S-TMA0Y	G105	PK5004ML05	B88	PS2429BP	B71	RG04MA0135	B36, B83
P8S-TMA0Y	L2, L3, L4	PK6004MA01	B36, B84	PS2429JBP	B71	RG04MA0171	B36, B83
P8S-TMC01	L2, L3, L4, L9	PK6004MA05	B36, B84	PS243079BP	B71	RG04MA0175	B36, B83
P8S-TMC02	L2, L3, L4, L9	PK6004ML01	B88	PS243083BP	B71	RG04MAH061	B83
P8S-TMC03	L2, L3, L4, L9	PK6004ML05	B88	PS2430J79BP	B71	RG04MAH065	B83
PDC15-FH	G121	PK8004MA01	B36, B84	PS2430J83BP	B71	RG04MAH101	B83
PDC15-LB	G121	PK8004MA05	B36, B84	PS2893C##P	B71	RG04MAH105	B83
PIC-4KMB	E119	PK8004ML01	B88	PS2893CP	B71	RG04MAH131	B83
PIC-4LMB	E119	PK8004ML05	B88	PS2893D83P	B71	RG04MAH135	B83
PIC-4MMB	E119	PKG 3-6/S90	E143, E160	PS2893DP	B71	RG04MAH171	B83
PIC-4NMB	E119	PKG 3M-6/S90	E143, E160	PS2932BP	B71	RG04MAH175	B83
PIC-4PMB	E119	PRL	K9	PS2932JBP	B71	RG04MAM061	B83
PIC-4QMB	E119	PRN Series	H11, H12	PS294679BP	B71	RG04MAM065	B83
PK032P1D01	B132	PRN150D	H14	PS294683BP	B71	RG04MAM101	B83
PK032P1D05	B132	PRN150-L	H19	PS2946J79BP	B71	RG04MAM105	B83
PK040P1D01	B132	PRN150-P	H19	PS2946J83BP	B71	RG04MAM131	B83
PK040P1D05	B132	PRN150S	H14	PSK-P5T100	E21	RG04MAM135	B83
PK050P1D01	B132	PRN300D	H14	PSK-P5T100-F	E21	RG04MAM171	B83
PK050P1D05	B132	PRN300-L	H19	PSK-P5T16	E21	RG04MAM175	B83
PK063P1D01	B132	PRN300S	H14	PSK-P5T16-F	E21	RG04ML0061	B87
PK063P1D05	B132	PRN30D	H14	PSK-P5T20	E21	RG04ML0065	B87
PK080P1D01	B132	PRN30-L	H18	PSK-P5T20-F	E21	RG04ML0101	B87
PK080P1D05	B132	PRN30-P	H18	PSK-P5T25	E21	RG04ML0105	B87
PK100P1D01	B132	PRN30S	H13, H14	PSK-P5T25-F	E21	RG04ML0131	B87
PK100P1D05	B132	PRN50D	H14	PSK-P5T32	E21	RG04ML0135	B87
PK125P1D01	B132	PRN50-L	H19	PSK-P5T32-F	E21	RG04ML0171	B87
PK125P1D05	B132	PRN50-P	H19	PSK-P5T40	E21	RG04ML0175	B87
PK1504MA01	B36, B84	PRN50S	H14	PSK-P5T40-F	E21	RG04MLH061	B87
PK1504MA05	B36, B84	PRN800D	H14	PSK-P5T50	E21	RG04MLH065	B87
PK1504ML01	B88	PRN800-L	H19	PSK-P5T50-F	E21	RG04MLH101	B87
PK1504ML05	B88	PRN800S	H14	PSK-P5T63	E21	RG04MLH105	B87
PK1A20-FH	G121	PRNA Series	H11, H12	PSK-P5T63-F	E21	RG04MLH131	B87
PK1A20-LB	G121	PRNA10D	H13	PSK-P5T80	E21	RG04MLH135	B87
PK1A25-FH	G121	PRNA10-L	H18	PSK-P5T80-F	E21	RG04MLH171	B87
PK1A25-LB	G121	PRNA10-P	H18	PTFL4PB6-1/8	G129	RG04MLH175	B87
PK2004MA01	B36, B84	PRNA10S	H13	PTR Series	H23, H24	RG04MLM061	B87
PK2004MA05	B36, B84	PRNA1D	H13	PV Series	H3	RG04MLM065	B87
PK2004ML01	B88	PRNA1-L	H18	PWBA3412	K5	RG04MLM101	B87
PK2004ML05	B88	PRNA1-P	H18	PWBA3468	K5	RG04MLM105	B87
PK2504MA01	B36, B84	PRNA1S	H13	PWBA3469	K5	RG04MLM131	B87
PK2504MA05	B36, B84	PRNA20D	H13	PWBA3493	K5	RG04MLM135	B87
PK2504ML01	B88	PRNA20-L	H18	PWBA3822	K5	RG04MLM171	B87

Application Fax Forms  
 Part Number Index  
 Safety Guide  
 Offer of Sale  
 Application Fax Forms, Part Number Index, Safety Guide, Offer of Sale



For inventory, lead times, and kit lookup, visit [www.pdnplu.com](http://www.pdnplu.com)

Model No.	Section / Page No.	Model No.	Section / Page No.	Model No.	Section / Page No.	Model No.	Section / Page No.
RG04MLM175.....	B87	SG2MNR2505.....	B103	SK50104ML1.....	B90	SRD Series.....	C2
RGOP1D0121.....	B132	SG2MNR3201.....	B103	SK50104ML5.....	B90	SRDM Series.....	C2
RGOP1D0125.....	B132	SG2MNR3205.....	B103	SK50304MA1.....	B36, B86	SRG.....	C34
RGOP1D0161.....	B132	SG2MNR4001.....	B103	SK50304MA5.....	B36, B86	SRGM.....	C34
RGOP1D0165.....	B132	SG2MNR4005.....	B103	SK50304ML1.....	B90	SRM Series.....	C2
RGOP1D0201.....	B132	SK032P1D01.....	B132	SK50304ML5.....	B90	SRX.....	C38
RGOP1D0205.....	B132	SK040P1D01.....	B132	SK60104MA1.....	B36, B86	SWH-1N.....	L3, L20
RGOP1D0251.....	B132	SK050P1D01.....	B132	SK60104MA5.....	B36, B86	SWH-1NC.....	L3, L20
RGOP1D0255.....	B132	SK063P1D01.....	B132	SK60104ML1.....	B90	SWH-1P.....	L2, L20
RGOP1D0321.....	B132	SK080P1D01.....	B132	SK60104ML5.....	B90	SWH-1PC.....	L2, L20
RGOP1D0325.....	B132	SK100P1D01.....	B132	SK60304MA1.....	B36, B86	SWH-2N.....	L3, L20
RKOP1D0121.....	B132	SK125P1D01.....	B132	SK60304MA5.....	B36, B86	SWH-2NC.....	L3, L20
RKOP1D0125.....	B132	SK15104MA1.....	B36, B86	SK60304ML1.....	B90	SWH-2P.....	L2, L20
RKOP1D0161.....	B132	SK15104MA5.....	B36, B86	SK60304ML5.....	B90	SWH-2PC.....	L2, L20
RKOP1D0165.....	B132	SK15104ML1.....	B90	SK80104MA1.....	B36, B86	SWR-1.....	L4, L21
RKOP1D0201.....	B132	SK15104ML5.....	B90	SK80104MA5.....	B36, B86	SWR-1C.....	L4, L21
RKOP1D0205.....	B132	SK15304MA1.....	B36, B86	SK80104ML1.....	B90	SWR-2.....	L4, L21
RKOP1D0251.....	B132	SK15304MA5.....	B36, B86	SK80104ML5.....	B90	SWR-2C.....	L4, L21
RKOP1D0255.....	B132	SK15304ML1.....	B90	SK80304MA1.....	B36, B86	W68GC-2-1.....	K3
RKOP1D0321.....	B132	SK15304ML5.....	B90	SK80304MA5.....	B36, B86	W68GC-2-2.....	K3
RKOP1D0325.....	B132	SK20104MA1.....	B36, B86	SK80304ML1.....	B90	W68GC-2-4.....	K3
RKM3-G1/5m.....	E143, E160	SK20104MA5.....	B36, B86	SK80304ML5.....	B90	W68GC-3-2.....	K3
RKMV3-G1/5m.....	E143, E160	SK20104ML1.....	B90	SKS05LP251.....	D13, D18	W68GC-3-4.....	K3
SC 190-1.....	M20	SK20104ML5.....	B90	SKS05LP255.....	D13, D18	W68GC-4-1.....	K3
SC 190-2.....	M20	SK20304MA1.....	B36, B86	SKS07LP311.....	D13, D18	W68GC-4-2.....	K3
SC 190-3.....	M20	SK20304MA5.....	B36, B86	SKS07LP315.....	D13, D18	W68GC-4-4.....	K3
SC 190-4.....	M20	SK20304ML1.....	B90	SKS12LP501.....	D13, D18	W68GC-4-6.....	K3
SC 300-1.....	M20	SK20304ML5.....	B90	SKS12LP505.....	D13, D18	W68GC-5/32-1.....	K3
SC 300-2.....	M20	SK25104MA1.....	B36, B86	SKS15LP621.....	D13, D18	W68GC-5/32-2.....	K3
SC 300-3.....	M20	SK25104MA5.....	B36, B86	SKS15LP625.....	D13, D18	W68GC-5/32-4.....	K3
SC 300-4.....	M20	SK25104ML1.....	B90	SKS20LP751.....	D13, D18	XLB Series.....	E145
SC 300-5.....	M22	SK25104ML5.....	B90	SKS20LP755.....	D13, D18	XLT / XLR Series.....	E120
SC 300-6.....	M22	SK25304MA1.....	B36, B86	SKS25LP751.....	D13, D18	XLT04.....	E142
SC 300-7.....	M22	SK25304MA5.....	B36, B86	SKS25LP755.....	D13, D18	XLT06.....	E142
SC 300-8.....	M22	SK25304ML1.....	B90	SKS30LP871.....	D13, D18	XLT08.....	E142
SC 300-9.....	M22	SK25304ML5.....	B90	SKS30LP875.....	D13, D18	XLT12.....	E142
SC 650-1.....	M20	SK32104MA1.....	B36, B86	SKS40LP101.....	D13, D18	ZSM25HD.....	G78
SC 650-2.....	M20	SK32104MA5.....	B36, B86	SKS40LP105.....	D13, D18		
SC 650-3.....	M20	SK32104ML1.....	B90	SMC-1N.....	L3, L18		
SC 650-4.....	M20	SK32104ML5.....	B90	SMC-1NC.....	L3, L18		
SC 650-5.....	M22	SK32304MA1.....	B36, B86	SMC-1P.....	L2, L18		
SC 650-6.....	M22	SK32304MA5.....	B36, B86	SMC-1PC.....	L2, L18		
SC 650-7.....	M22	SK32304ML1.....	B90	SMD-1L.....	L4, L19		
SC 650-8.....	M22	SK32304ML5.....	B90	SMD-1LC.....	L4		
SC 650-9.....	M22	SK40104MA1.....	B36, B86	SMD-1LD.....	L19		
SC 925-1.....	M20	SK40104MA5.....	B36, B86	SMH-1N.....	L3, L18		
SC 925-2.....	M20	SK40104ML1.....	B90	SMH-1NC.....	L18		
SC 925-3.....	M20	SK40104ML5.....	B90	SMH-1P.....	L2, L18		
SC 925-4.....	M20	SK40304MA1.....	B36, B86	SMH-1PC.....	L2, L18		
SC300M-3 NB.....	G129	SK40304MA5.....	B36, B86	SMR-1.....	L4, L19		
SG2MNR1501.....	B103	SK40304ML1.....	B90	SMR-1C.....	L4, L19		
SG2MNR1505.....	B103	SK40304ML5.....	B90	SMR-1L.....	L4, L19		
SG2MNR2001.....	B103	SK50104MA1.....	B36, B86	SMR-1LC.....	L4, L19		
SG2MNR2501.....	B103	SK50104MA5.....	B36, B86	SR Series.....	C2		

Application  
Fax Forms

Part Number  
Index

Safety  
Guide

Offer of  
Sale

Application Fax Forms,  
Part Number Index, Safety  
Guide, Offer of Sale

**N**



For inventory, lead time, and kit lookup, visit [www.pdnplu.com](http://www.pdnplu.com)

Safety Guide for Selecting and Using Hydraulic, Pneumatic Cylinders and Their Accessories

**WARNING: ⚠ FAILURE OF THE CYLINDER, ITS PARTS, ITS MOUNTING, ITS CONNECTIONS TO OTHER OBJECTS, OR ITS CONTROLS CAN RESULT IN:**

- Unanticipated or uncontrolled movement of the cylinder or objects connected to it.
- Falling of the cylinder or objects held up by it.
- Fluid escaping from the cylinder, potentially at high velocity.

**THESE EVENTS COULD CAUSE DEATH OR PERSONAL INJURY BY, FOR EXAMPLE, PERSONS FALLING FROM HIGH LOCATIONS, BEING CRUSHED OR STRUCK BY HEAVY OR FAST MOVING OBJECTS, BEING PUSHED INTO DANGEROUS EQUIPMENT OR SITUATIONS, OR SLIPPING ON ESCAPED FLUID.**

Before selecting or using Parker (The Company) cylinders or related accessories, it is important that you read, understand and follow the following safety information. Training is advised before selecting and using The Company's products.

**1.0 General Instructions**

**1.1 Scope** – This safety guide provides instructions for selecting and using (including assembling, installing, and maintaining) cylinder products. This safety guide is a supplement to and is to be used with the specific Company publications for the specific cylinder products that are being considered for use.

**1.2 Fail Safe** – Cylinder products can and do fail without warning for many reasons. All systems and equipment should be designed in a fail-safe mode so that if the failure of a cylinder product occurs people and property won't be endangered.

**1.3 Distribution** – Provide a free copy of this safety guide to each person responsible for selecting or using cylinder products. Do not select or use The Company's cylinders without thoroughly reading and understanding this safety guide as well as the specific Company publications for the products considered or selected.

**1.4 User Responsibility** – Due to very wide variety of cylinder applications and cylinder operating conditions, The Company does not warrant that any particular cylinder is suitable for any specific application. This safety guide does not analyze all technical parameters that must be considered in selecting a product. The hydraulic and pneumatic cylinders outlined in this catalog are designed to The Company's design guidelines and do not necessarily meet the design guideline of other agencies such as American Bureau of Shipping, ASME Pressure Vessel Code etc. The user, through its own analysis and testing, is solely responsible for:

- Making the final selection of the cylinders and related accessories.
- Determining if the cylinders are required to meet specific design requirements as required by the Agency(s) or industry standards covering the design of the user's equipment.
- Assuring that the user's requirements are met, OSHA requirements are met, and safety guidelines from the applicable agencies such as but not limited to ANSI are followed and that the use presents no health or safety hazards.
- Providing all appropriate health and safety warnings on the equipment on which the cylinders are used.

**1.5 Additional Questions** – Call the appropriate Company technical service department if you have any questions or require any additional information. See the Company publication for the product being considered or used, or call 1-800-CPARKER, or go to [www.parker.com](http://www.parker.com), for telephone numbers of the appropriate technical service department.

**2.0 Cylinder and Accessories Selection**

**2.1 Seals** – Part of the process of selecting a cylinder is the selection of seal compounds. Before making this selection, consult the "seal information page(s)" of the publication for the series of cylinders of interest.

The application of cylinders may allow fluids such as cutting fluids, wash down fluids etc. to come in contact with the external area of the cylinder. These fluids may attack the piston rod wiper and or the primary seal and must be taken into account when selecting and specifying seal compounds.

Dynamic seals will wear. The rate of wear will depend on many operating factors. Wear can be rapid if a cylinder is mis-aligned or if the cylinder has been improperly serviced. The user must take seal wear into consideration in the application of cylinders.

**2.2 Piston Rods** – Possible consequences of piston rod failure or separation of the piston rod from the piston include, but are not limited to are:

- Piston rod and or attached load thrown off at high speed.
- High velocity fluid discharge.
- Piston rod extending when pressure is applied in the piston retract mode.

Piston rods or machine members attached to the piston rod may move suddenly and without warning as a consequence of other conditions occurring to the machine such as, but not limited to:

- Unexpected detachment of the machine member from the piston rod.
- Failure of the pressurized fluid delivery system (hoses, fittings, valves, pumps, compressors) which maintain cylinder position.
- Catastrophic cylinder seal failure leading to sudden loss of pressurized fluid.
- Failure of the machine control system.

Follow the recommendations of the "Piston Rod Selection Chart and Data" in the publication for the series of cylinders of interest. The suggested piston rod diameter in these charts must be followed in order to avoid piston rod buckling.

Piston rods are not normally designed to absorb bending moments or loads which are perpendicular to the axis of piston rod motion. These additional loads can cause the piston rod to fail. If these types of additional loads are expected to be imposed on the piston rod, their magnitude should be made known to our engineering department.

The cylinder user should always make sure that the piston rod is securely attached to the machine member.

On occasion cylinders are ordered with double rods (a piston rod extended from both ends of the cylinder). In some cases a stop is threaded on to one of the piston rods and used as an external stroke adjuster. On occasions spacers are attached to the machine member connected to the piston rod and also used as a stroke adjuster. In both cases the stops will create a pinch point and the user should consider appropriate use of guards. If these external stops are not perpendicular to the mating contact surface, or if debris is trapped between the contact surfaces, a bending moment will be placed on the piston rod, which can lead to piston rod failure. An external stop will also negate the effect of cushioning and will subject the piston rod to impact loading. Those two (2) conditions can cause piston rod failure. Internal stroke adjusters are available with and without cushions. The use of external stroke adjusters should be reviewed with our engineering department.

The piston rod to piston and the stud to piston rod threaded connections are secured with an anaerobic adhesive. The strength of the adhesive decreases with increasing temperature. Cylinders which can be exposed to temperatures above +250°F (+121°C) are to be ordered with a non studded piston rod and a pinned piston to rod joint.

**2.3 Cushions** – Cushions should be considered for cylinder applications when the piston velocity is expected to be over 4 inches/second.

Cylinder cushions are normally designed to absorb the energy of a linear applied load. A rotating mass has considerably more energy than the same mass moving in a linear mode. Cushioning for a rotating mass application should be review by our engineering department.

**2.4 Cylinder Mountings** – Some cylinder mounting configurations may have certain limitations such as but not limited to minimum stroke for side or foot mounting cylinders or pressure de-ratings for certain mounts. Carefully review the catalog for these types of restrictions.

Always mount cylinders using the largest possible high tensile alloy steel socket head cap screws that can fit in the cylinder mounting holes and torque them to the manufacturer's recommendations for their size.

**2.5 Port Fittings** – Hydraulic cylinders applied with meter out or deceleration circuits are subject to intensified pressure at piston rod end.

The rod end pressure is approximately equal to:

$$\frac{\text{operating pressure} \times \text{effective cap end area}}{\text{effective rod end piston area}}$$

Contact your connector supplier for the pressure rating of individual connectors.

**3.0 Cylinder and Accessories Installation and Mounting**

**3.1 Installation**

**3.1.1** – Cleanliness is an important consideration, and cylinders are shipped with the ports plugged to protect them from contaminants entering the ports. These plugs should not be removed until the piping is to be installed. Before making the connection to the cylinder ports, piping should be thoroughly cleaned to remove all chips or burrs which might have resulted from threading or flaring operations.

Application Fax Forms	Part Number Index	Safety Guide	Offer of Sale	Application Fax Forms, Part Number Index, Safety Guide, Offer of Sale
-----------------------	-------------------	--------------	---------------	---



For inventory, lead times, and kit lookup, visit [www.pdnplu.com](http://www.pdnplu.com)

**3.1.2** – Cylinders operating in an environment where air drying materials are present such as fast-drying chemicals, paint, or weld splatter, or other hazardous conditions such as excessive heat, should have shields installed to prevent damage to the piston rod and piston rod seals.

**3.1.3** – Proper alignment of the cylinder piston rod and its mating component on the machine should be checked in both the extended and retracted positions. Improper alignment will result in excessive rod gland and/or cylinder bore wear. On fixed mounting cylinders attaching the piston rod while the rod is retracted will help in achieving proper alignment.

**3.1.4** – Sometimes it may be necessary to rotate the piston rod in order to thread the piston rod into the machine member. This operation must always be done with zero pressure being applied to either side of the piston. Failure to follow this procedure may result in loosening the piston to rod-threaded connection. In some rare cases the turning of the piston rod may rotate a threaded piston rod gland and loosen it from the cylinder head. Confirm that this condition is not occurring. If it does, re-tighten the piston rod gland firmly against the cylinder head.

For double rod cylinders it is also important that when attaching or detaching the piston rod from the machine member that the torque be applied to the piston rod end of the cylinder that is directly attaching to the machine member with the opposite end unrestrained. If the design of the machine is such that only the rod end of the cylinder opposite to where the rod attaches to the machine member can be rotated, consult the factory for further instructions.

### 3.2 Mounting Recommendations

**3.2.1** – Always mount cylinders using the largest possible high tensile alloy steel socket head screws that can fit in the cylinder mounting holes and torque them to the manufacturer's recommendations for their size.

**3.2.2** – Side-Mounted Cylinders – In addition to the mounting bolts, cylinders of this type should be equipped with thrust keys or dowel pins located so as to resist the major load.

**3.2.3** – Tie Rod Mounting – Cylinders with tie rod mountings are recommended for applications where mounting space is limited. The standard tie rod extension is shown as BB in dimension tables. Longer or shorter extensions can be supplied. Nuts used for this mounting style should be torqued to the same value as the tie rods for that bore size.

**3.2.4** – Flange Mount Cylinders – The controlled diameter of the rod gland extension on head end flange mount cylinders can be used as a pilot to locate the cylinders in relation to the machine. After alignment has been obtained, the flanges may be drilled for pins or dowels to prevent shifting.

**3.2.5** – Trunnion Mountings – Cylinders require lubricated bearing blocks with minimum bearing clearances. Bearing blocks should be carefully aligned and rigidly mounted so the trunnions will not be subjected to bending moments. The rod end should also be pivoted with the pivot pin in line and parallel to axis of the trunnion pins.

**3.2.6** – Clevis Mountings – Cylinders should be pivoted at both ends with centerline of pins parallel to each other. After cylinder is mounted, be sure to check to assure that the cylinder is free to swing through its working arc without interference from other machine parts.

### 4.0 Cylinder and Accessories Maintenance, Troubleshooting and Replacement

**4.1 Storage** – At times cylinders are delivered before a customer is ready to install them and must be stored for a period of time. When storage is required the following procedures are recommended.

**4.1.1** – Store the cylinders in an indoor area which has a dry, clean and noncorrosive atmosphere. Take care to protect the cylinder from both internal corrosion and external damage.

**4.1.2** – Whenever possible cylinders should be stored in a vertical position (piston rod up). This will minimize corrosion due to possible condensation which could occur inside the cylinder. This will also minimize seal damage.

**4.1.3** – Port protector plugs should be left in the cylinder until the time of installation.

**4.1.4** – If a cylinder is stored full of hydraulic fluid, expansion of the fluid due to temperature changes must be considered. Installing a check valve with free flow out of the cylinder is one method.

**4.1.5** – When cylinders are mounted on equipment that is stored outside for extended periods, exposed unpainted surfaces, e.g. piston rod, must be coated with a rust-inhibiting compound to prevent corrosion.

### 4.2 Cylinder Trouble Shooting

#### 4.2.1 – External Leakage

**4.2.1.1** – Rod seal leakage can generally be traced to worn or damaged seals. Examine the piston rod for dents, gouges or score marks, and replace piston rod if surface is rough.

Rod seal leakage could also be traced to gland wear. If clearance is excessive, replace rod bushing and seal. Rod seal leakage can also be traced to seal deterioration. If seals are soft or gummy or brittle, check compatibility of seal material with lubricant used if air cylinder, or operating fluid if hydraulic cylinder. Replace with seal material, which is compatible with these fluids. If the seals are hard or have lost elasticity, it is usually due to exposure to temperatures in excess of 165°F. (+74°C). Shield the cylinder from the heat source to limit temperature to 350°F. (+177°C.) and replace with fluorocarbon seals.

**4.2.1.2** – Cylinder body seal leak can generally be traced to loose tie rods. Torque the tie rods to manufacturer's recommendation for that bore size.

Excessive pressure can also result in cylinder body seal leak. Determine maximum pressure to rated limits. Replace seals and retorque tie rods as in paragraph above. Excessive pressure can also result in cylinder body seal leak. Determine if the pressure rating of the cylinder has been exceeded. If so, bring the operating pressure down to the rating of the cylinder and have the tie rods replaced.

Pinched or extruded cylinder body seal will also result in a leak. Replace cylinder body seal and retorque as in paragraph above.

Cylinder body seal leakage due to loss of radial squeeze which shows up in the form of flat spots or due to wear on the O.D. or I.D. – Either of these are symptoms of normal wear due to high cycle rate or length of service. Replace seals as per paragraph above.

#### 4.2.2 – Internal Leakage

**4.2.2.1** – Piston seal leak (by-pass) 1 to 3 cubic inches per minute leakage is considered normal for piston ring construction. Virtually no static leak with lipseal type seals on piston should be expected. Piston seal wear is a usual cause of piston seal leakage. Replace seals as required.

**4.2.2.2** – With lipseal type piston seals excessive back pressure due to over-adjustment of speed control valves could be a direct cause of rapid seal wear. Contamination in a hydraulic system can result in a scored cylinder bore, resulting in rapid seal wear. In either case, replace piston seals as required.

**4.2.2.3** – What appears to be piston seal leak, evidenced by the fact that the cylinder drifts, is not always traceable to the piston. To make sure, it is suggested that one side of the cylinder piston be pressurized and the fluid line at the opposite port be disconnected. Observe leakage. If none is evident, seek the cause of cylinder drift in other component parts in the circuit.

#### 4.2.3 – Cylinder Fails to Move the Load

**4.2.3.1** – Pneumatic or hydraulic pressure is too low. Check the pressure at the cylinder to make sure it is to circuit requirements.

**4.2.3.2** – Piston Seal Leak – Operate the valve to cycle the cylinder and observe fluid flow at valve exhaust ports at end of cylinder stroke. Replace piston seals if flow is excessive.

**4.2.3.3** – Cylinder is undersized for the load – Replace cylinder with one of a larger bore size.

#### 4.3 Erratic or Chatter Operation

**4.3.1** – Excessive friction at rod gland or piston bearing due to load misalignment – Correct cylinder-to-load alignment.

**4.3.2** – Cylinder sized too close to load requirements – Reduce load or install larger cylinder.

**4.3.3** – Erratic operation could be traced to the difference between static and kinetic friction. Install speed control valves to provide a back pressure to control the stroke.

**4.4 Cylinder Modifications, Repairs, or Failed Component** – Cylinders as shipped from the factory are not to be disassembled and/or modified. If cylinders require modifications, these modifications must be done at company locations or by The Company's certified facilities. The Cylinder Division Engineering Department must be notified in the event of a mechanical fracture or permanent deformation of any cylinder component (excluding seals). This includes a broken piston rod, tie rod, mounting accessory or any other cylinder component. The notification should include all operation and application details. This information will be used to provide an engineered repair that will prevent recurrence of the failure.

It is allowed to disassemble cylinders for the purpose of replacing seals or seal assemblies. However, this work must be done by strictly following all the instructions provided with the seal kits.

Application  
Fax FormsPart Number  
IndexSafety  
GuideOffer of  
SaleApplication Fax Forms,  
Part Number Index, Safety  
Guide, Offer of Sale

N



For inventory, lead time, and kit lookup, visit [www.pdnplu.com](http://www.pdnplu.com)

N17

**Parker Hannifin Corporation**  
Pneumatic Division  
Richland, Michigan  
[www.parker.com/pneumatics](http://www.parker.com/pneumatics)

The goods, services or work (referred to as the “Products”) offered by **Parker-Hannifin Corporation**, its subsidiaries, groups, divisions, and authorized distributors (“Seller”) are offered for sale at prices indicated in the offer, or as may be established by Seller. The offer to sell the Products and acceptance of Seller’s offer by any customer (“Buyer”) is contingent upon, and will be governed by all of the terms and conditions contained in this Offer of Sale. Buyer’s order for any Products specified in Buyer’s purchase document or Seller’s offer, proposal or quote (“Quote”) attached to the purchase order, when communicated to Seller verbally, or in writing, shall constitute acceptance of this offer.

- 1. Terms and Conditions.** Seller’s willingness to offer Products for sale or accept an order for Products is subject to the terms and conditions contained in this Offer of Sale or any newer version of the same, published by Seller electronically at [www.parker.com/saleterms/](http://www.parker.com/saleterms/). Seller objects to any contrary or additional terms or conditions of Buyer’s order or any other document or other communication issued by Buyer.
- 2. Price; Payment.** Prices stated on Seller’s Quote are valid for thirty (30) days, except as explicitly otherwise stated therein, and do not include any sales, use, or other taxes or duties unless specifically stated. Seller reserves the right to modify prices to adjust for any raw material price fluctuations. Unless otherwise specified by Seller, all prices are F.C.A. Seller’s facility (INCOTERMS 2010). Payment is subject to credit approval and payment for all purchases is due thirty (30) days from the date of invoice (or such date as may be specified by Seller’s Credit Department). Unpaid invoices beyond the specified payment date incur interest at the rate of 1.5% per month or the maximum allowable rate under applicable law.
- 3. Shipment; Delivery; Title and Risk of Loss.** All delivery dates are approximate. Seller is not responsible for damages resulting from any delay. Regardless of the manner of shipment, delivery occurs and title and risk of loss or damage pass to Buyer, upon placement of the Products with the shipment carrier at Seller’s facility. Unless otherwise stated, Seller may exercise its judgment in choosing the carrier and means of delivery. No deferral of shipment at Buyers’ request beyond the respective dates indicated will be made except on terms that will indemnify, defend and hold Seller harmless against all loss and additional expense. Buyer shall be responsible for any additional shipping charges incurred by Seller due to Buyer’s acts or omissions.
- 4. Warranty.** Seller warrants that the Products sold hereunder shall be free from defects in material or workmanship for a period of twelve (12) months from the date of delivery or 2,000 hours of normal use, whichever occurs first. All prices are based upon the exclusive limited warranty stated above, and upon the following disclaimer: **DISCLAIMER OF WARRANTY: THIS WARRANTY IS THE SOLE AND ENTIRE WARRANTY PERTAINING TO PRODUCTS PROVIDED. SELLER DISCLAIMS ALL OTHER WARRANTIES, EXPRESS AND IMPLIED, INCLUDING DESIGN, MERCHANTABILITY AND FITNESS FOR A PARTICULAR PURPOSE.**
- 5. Claims; Commencement of Actions.** Buyer shall promptly inspect all Products upon receipt. No claims for shortages will be allowed unless reported to the Seller within ten (10) days of delivery. No other claims against Seller will be allowed unless asserted in writing within thirty (30) days after delivery. Buyer shall notify Seller of any alleged breach of warranty within thirty (30) days after the date the defect is or should have been discovered by Buyer. Any claim or action against Seller based upon breach of contract or any other theory, including tort, negligence, or otherwise must be commenced within twelve (12) months from the date of the alleged breach or other alleged event, without regard to the date of discovery.
- 6. LIMITATION OF LIABILITY.** IN THE EVENT OF A BREACH OF WARRANTY, SELLER WILL, AT ITS OPTION, REPAIR OR REPLACE A DEFECTIVE PRODUCT, OR REFUND THE PURCHASE PRICE WITHIN A REASONABLE PERIOD OF TIME. **IN NO EVENT IS SELLER LIABLE FOR ANY SPECIAL, INDIRECT, INCIDENTAL OR CONSEQUENTIAL DAMAGES ARISING OUT OF, OR AS THE RESULT OF, THE SALE, DELIVERY, NON-DELIVERY, SERVICING, USE OR LOSS OF USE OF THE PRODUCTS OR ANY PART THEREOF, OR FOR ANY CHARGES OR EXPENSES OF ANY NATURE INCURRED WITHOUT SELLER’S WRITTEN CONSENT, WHETHER BASED IN CONTRACT, TORT OR OTHER LEGAL THEORY. IN NO EVENT SHALL SELLER’S LIABILITY UNDER ANY CLAIM MADE BY BUYER EXCEED THE PURCHASE PRICE OF THE PRODUCTS.**
- 7. User Responsibility.** The user, through its own analysis and testing, is solely responsible for making the final selection of the system and Product and assuring that all performance, endurance, maintenance, safety and warning requirements of the application are met. The user must analyze all aspects of the application and follow applicable industry standards and Product information. If Seller provides Product or system options based upon data or specifications provided by the user, the user is responsible for determining that such data and specifications are suitable and sufficient for all applications and reasonably foreseeable uses of the Products or systems.
- 8. Loss to Buyer’s Property.** Any designs, tools, patterns, materials, drawings, confidential information or equipment furnished by Buyer or any other items which become Buyer’s property, will be considered obsolete and may be destroyed by Seller after two (2) consecutive years have elapsed without Buyer ordering the items manufactured using such property. Seller shall not be responsible for any loss or damage to such property while it is in Seller’s possession or control.
- 9. Special Tooling.** A tooling charge may be imposed for any special tooling, including without limitation, dies, fixtures, molds and patterns, acquired to manufacture Products. Such special tooling shall be and remain Seller’s property notwithstanding payment of any charges by Buyer. In no event will Buyer acquire any interest in apparatus belonging to Seller which is utilized in the manufacture of the Products, even if such apparatus has been specially converted or adapted for such manufacture and notwithstanding any charges paid by Buyer. Unless otherwise agreed, Seller has the right to alter, discard or otherwise dispose of any special tooling or other property in its sole discretion at any time.
- 10. Buyer’s Obligation; Rights of Seller.** To secure payment of all sums due or otherwise, Seller retains a security interest in all Products delivered to Buyer and this agreement is deemed to be a Security Agreement under the Uniform Commercial Code. Buyer authorizes Seller as its attorney to execute and file on Buyer’s behalf all documents Seller deems necessary to perfect its security interest.
- 11. Improper Use and Indemnity.** Buyer shall indemnify, defend, and hold Seller harmless from any losses, claims, liabilities, damages, lawsuits, judgments and costs

- (including attorney fees and defense costs), whether for personal injury, property damage, patent, trademark or copyright infringement or any other claim, brought by or incurred by Buyer, Buyer’s employees, or any other person, arising out of: (a) improper selection, application, design, specification or other misuse of Products purchased by Buyer from Seller; (b) any act or omission, negligent or otherwise, of Buyer; (c) Seller’s use of patterns, plans, drawings, or specifications furnished by Buyer to manufacture Products; or (d) Buyer’s failure to comply with these terms and conditions. Seller shall not indemnify Buyer under any circumstance except as otherwise provided.
- 12. Cancellations and Changes.** Buyer may not cancel or modify or cancel any order for any reason, except with Seller’s written consent and upon terms that will indemnify, defend and hold Seller harmless against all direct, incidental and consequential loss or damage. Seller may change Product features, specifications, designs and availability.
- 13. Limitation on Assignment.** Buyer may not assign its rights or obligations under this agreement without the prior written consent of Seller.
- 14. Force Majeure.** Seller does not assume the risk and is not liable for delay or failure to perform any of Seller’s obligations by reason of events or circumstances beyond its reasonable control (hereinafter “Events of Force Majeure”). Events of Force Majeure shall include without limitation: accidents, strikes or labor disputes, acts of any government or government agency, acts of nature, delays or failures in delivery from carriers or suppliers, shortages of materials, or any other cause beyond Seller’s reasonable control.
- 15. Waiver and Severability.** Failure to enforce any provision of this agreement will not invalidate that provision; nor will any such failure prejudice Seller’s right to enforce that provision in the future. Invalidation of any provision of this agreement by legislation or other rule of law shall not invalidate any other provision herein. The remaining provisions of this agreement will remain in full force and effect.
- 16. Termination.** Seller may terminate this agreement for any reason and at any time by giving Buyer thirty (30) days prior written notice. Seller may immediately terminate this agreement, in writing, if Buyer: (a) breaches any provision of this agreement (b) appoints a trustee, receiver or custodian for all or any part of Buyer’s property (c) files a petition for relief in bankruptcy on its own behalf, or one if filed by a third party (d) makes an assignment for the benefit of creditors; or (e) dissolves its business or liquidates all or a majority of its assets.
- 17. Governing Law.** This agreement and the sale and delivery of all Products are deemed to have taken place in, and shall be governed and construed in accordance with, the laws of the State of Ohio, as applicable to contracts executed and wholly performed therein and without regard to conflicts of laws principles. Buyer irrevocably agrees and consents to the exclusive jurisdiction and venue of the courts of Cuyahoga County, Ohio with respect to any dispute, controversy or claim arising out of or relating to this agreement.
- 18. Indemnity for Infringement of Intellectual Property Rights.** Seller is not liable for infringement of any patents, trademarks, copyrights, trade dress, trade secrets or similar rights except as provided in this Section. Seller will defend and indemnify Buyer against allegations of infringement of U.S. patents, U.S. trademarks, copyrights, trade dress and trade secrets (“Intellectual Property Rights”). Seller will defend at its expense and will pay the cost of any settlement or damages awarded in an action brought against Buyer based on an allegation that a Product sold pursuant to this agreement infringes the Intellectual Property Rights of a third party. Seller’s obligation to defend and indemnify Buyer is contingent on Buyer notifying Seller within ten (10) days after Buyer becomes aware of such allegations of infringement, and Seller having sole control over the defense of any allegations or actions including all negotiations for settlement or compromise. If a Product is subject to a claim that it infringes the Intellectual Property Rights of a third party, Seller may, at its sole expense and option, procure for Buyer the right to continue using the Product, replace or modify the Product so as to make it noninfringing, or offer to accept return of the Product and refund the purchase price less a reasonable allowance for depreciation. Notwithstanding the foregoing, Seller is not liable for claims of infringement based on information provided by Buyer, or directed to Products delivered hereunder for which the designs are specified in whole or part by Buyer, or infringements resulting from the modification, combination or use in a system of any Product sold hereunder. The foregoing provisions of this Section constitute Seller’s sole and exclusive liability and Buyer’s sole and exclusive remedy for infringement of Intellectual Property Rights.
- 19. Entire Agreement.** This agreement contains the entire agreement between the Buyer and Seller and constitutes the final, complete and exclusive expression of the terms of sale. All prior or contemporaneous written or oral agreements or negotiations with respect to the subject matter are herein merged. The terms contained herein may not be modified unless in writing and signed by an authorized representative of Seller.
- 20. Compliance with Laws.** Buyer agrees to comply with all applicable laws, regulations, and industry and professional standards of care, including those of the United Kingdom, the United States of America, and the country or countries in which Buyer may operate, including without limitation the U. K. Bribery Act, the U.S. Foreign Corrupt Practices Act (“FCPA”), the U.S. Anti-Kickback Act (“Anti-Kickback Act”) and the U.S. Food Drug and Cosmetic Act (“FDCA”), each as currently amended, and the rules and regulations promulgated by the U.S. Food and Drug Administration (“FDA”), and agrees to indemnify and hold harmless Seller from the consequences of any violation of such provisions by Buyer, its employees or agents. Buyer acknowledges that it is familiar with the provisions of the U. K. Bribery Act, the FCPA, the FDA, and the Anti-Kickback Act, and certifies that Buyer will adhere to the requirements thereof. In particular, Buyer represents and agrees that Buyer will not make any payment or give anything of value, directly or indirectly to any governmental official, any foreign political party or official thereof, any candidate for foreign political office, or any commercial entity or person, for the purpose of influencing such person to purchase Products or otherwise benefit the business of Seller.

Application Fax Forms	Part Number Index	Safety Guide	Offer of Sale	Application Fax Forms, Part Number Index, Safety Guide, Offer of Sale
-----------------------	-------------------	--------------	---------------	---



For inventory, lead times, and kit lookup, visit [www.pdnplu.com](http://www.pdnplu.com)

N18

**Parker Hannifin Corporation**  
Pneumatic Division  
Richland, Michigan  
[www.parker.com/pneumatics](http://www.parker.com/pneumatics)





Parker Hannifin Corporation  
**Pneumatic Division**  
135 Quadral Drive  
Wadsworth, OH 44281 USA  
Tel: (269) 629-5000  
Fax: (269) 629-5385

Applications Engineering

Phone: (269) 629-5575 Option #3  
E-mail: [pdnapps@parker.com](mailto:pdnapps@parker.com)

Customer Support

Phone: (269) 629-5575 Option #1  
E-mail: [pdncustsvc@parker.com](mailto:pdncustsvc@parker.com)  
Web site: [www.parker.com/pneumatics](http://www.parker.com/pneumatics)