



Volume 14: Fuses

EATON

Powering Business Worldwide

Tab 1—Fuses General V14-T1-1
Tab 2—Expulsion Fuses V14-T2-1
Tab 3—Current Limiting Fuses V14-T3-1
Appendix 1—Eaton Terms & Conditions V14-A1-1
Appendix 2—Superseded Style Number Index..... V14-A2-1
Appendix 3—Catalog Number/Style Number Cross Reference V14-A3-1



Dimensions, Weights and Ratings

Dimensions, weights and ratings given in this catalog **are approximate and should not be used for construction purposes**. Drawings containing exact dimensions are available upon request. All listed product specifications and ratings are subject to change without notice. Photographs are representative of production units.

Terms and Conditions

All prices and discounts are subject to change without notice. When price changes occur, they are published in the *Eaton Corporation Price and Availability Digest* (PAD). All orders accepted by Eaton's electrical sector are subject to the general terms and conditions as set forth in Appendix 1—Eaton Terms & Conditions.

Technical and Descriptive Publications

This catalog contains brief technical data for proper selection of products. Further information is available in the form of technical information publications and illustrated brochures. If additional product information is required, contact your local Eaton Products Distributor, call **1-800-525-2000** or visit our Web site at **www.eaton.com**.

Compliance with Nuclear Regulation 10 CFR 21

Eaton products are sold as commercial grade products not intended for application in facilities or activities licensed by the United States Nuclear Regulatory Commission for atomic purposes, under 10 CFR 21. Further certification will be required for use of these products in a safety-related application in any nuclear facility licensed by the U.S. Nuclear Regulatory Commission.

WARNING

The installation and use of Eaton products should be in accordance with the provisions of the U.S. National Electrical Code® and/or other local codes or industry standards that are pertinent to the particular end use. Installation or use not in accordance with these codes and standards could be hazardous to personnel and/or equipment.

These catalog pages do not purport to cover all details or variations in equipment, nor to provide for every possible contingency to be met in connection with installation, operation or maintenance. Should further information be desired or should particular problems arise which are not covered sufficiently for the purchaser's purposes, the matter should be referred to the local Eaton Products Distributor or Sales Office. The contents of this catalog shall not become part of or modify any prior or existing agreement, commitment or relationship. The sales contract contains the entire obligation of Eaton's electrical sector. The warranty contained in the contract between the parties is the sole warranty of Eaton. Any statements contained herein do not create new warranties or modify the existing warranty.



Powering Business Worldwide

Eaton Corporation is a global leader in power distribution, power quality, control and automation, and monitoring products.

At Eaton, we believe a reliable, efficient and safe power system is the foundation of every successful enterprise. Through innovative technologies, cutting-edge products and our highly skilled services team, we empower businesses around the world to achieve a powerful advantage.

In addition, Eaton is committed to creating and maintaining powerful customer relationships built on a foundation of excellence. From the products we manufacture to our dedicated customer service and support, we know what's important to you.

Solutions

Eaton takes the complexity out of power systems management with a holistic and strategic approach, leveraging our industry-leading technology, solutions and services. We focus on the following three areas in all we do:

- Reliability—maintain the appropriate level of power continuity without disruption or unexpected downtime
- Efficiency—minimize energy usage, operating costs, equipment footprint and environmental impact
- Safety—identify and mitigate electrical hazards to protect what you value most

Using the Eaton Catalog Library

As we grow, it becomes increasingly difficult to include all products in one or two comprehensive catalogs. Knowing that each user has their specific needs, we have created a library of catalogs for our products that when complete, will contain 14 volumes. Since the volumes will continuously be a work in progress and updated, each volume will stand alone. Refer to our volume directory, MZ08100001E, for a quick glance of where to look for the products you need. The 14 volumes include:

- Volume 1—Residential and Light Commercial (CA08100002E)
- Volume 2—Commercial Distribution (CA08100003E)
- Volume 3—Power Distribution and Control Assemblies (CA08100004E)
- Volume 4—Circuit Protection (CA08100005E)
- Volume 5—Motor Control and Protection (CA08100006E)
- Volume 6—Solid-State Motor Control (CA08100007E)
- Volume 7—Logic Control, Operator Interface and Connectivity Solutions (CA08100008E)
- Volume 8—Sensing Solutions (CA08100010E)
- Volume 9—Original Equipment Manufacturer (CA08100011E)
- Volume 10—Enclosed Control (CA08100012E)
- Volume 11—Vehicle and Commercial Controls (CA08100013E)
- Volume 12—Aftermarket, Renewal Parts and Life Extension Solutions (CA08105001E)
- Volume 13—Counters, Timers and Tachometers (CA08100015E)—Available in electronic format only
- Volume 14—Fuses (CA08100016E)—Available in electronic format only

These volumes are not all-inclusive of every product, but they are meant to be an overview of our product lines. For our full range of product solutions and additional product information, consult Eaton.com/electrical and other catalogs and product guides in our literature library. These references include:

- The Consulting Application Guide (CA08104001E)
- The Eaton Power Quality Product Guide (COR01FYA)

If you don't have the volume that contains the product or information that you are looking for, not to worry. You can access every volume of the catalog library at Eaton.com/electrical in the Literature Library.

By installing our Automatic Tab Updater (ATU), you can be sure you always have the most recent version of each volume and tab.

Icons



Green Leaf

Eaton Green Solutions are products, systems or solutions that represent Eaton benchmarks for environmental performance. The green leaf symbol is our promise that the solution has been reviewed and documented as offering exceptional, industry-leading environmental benefits to customers, consumers and our communities. Though all of Eaton's products and solutions are designed to meet or exceed applicable government standards related to protecting the environment, our products with the Green Leaf designation further provide "exceptional environmental benefit".



Learn Online

When you see the Learn Online icon, go to Eaton.com/electrical and search for the product or training page. There you will find 100-level training courses, podcasts, webcasts or games and puzzles to learn more.



Drawings Online

When you see the Drawings Online icon, go to Eaton.com/electrical and find the products page. There you will find a tab that includes helpful product drawings and illustrations.

Contact Us

If you need additional help, you can find contact information under the Customer Care heading of Eaton.com/electrical.

Current Limiting Fuses



1.1 Product Overview

Power Fuse	V14-T1-2
Power vs. Distribution	V14-T1-2
Low vs. Medium vs. High Voltage	V14-T1-2
Expulsion vs. Current Limiting (Definitions per ANSI C47.40-1993)...	V14-T1-3
Current Limiting Fuse Types.....	V14-T1-3
General Fuse Component Terms	V14-T1-3

Expulsion Fuses



Typical Eaton Fuses



Product Overview

Power Fuse

Eaton's roots in the medium voltage power fuse business began over 75 years ago under Westinghouse® Electric. In 1935, Westinghouse introduced the medium voltage boric acid expulsion fuse followed by the medium voltage current limiting fuse. Even today, medium voltage fuses continue to use that core technology. Eaton continues to build on the technology legacy by engineering high performance, cost-effective power fuse products.

Eaton's medium voltage fuses are manufactured and tested to the requirements of the C37-4X series of standards that are maintained and updated regularly to maintain currency with industry practices. These standards are:

IEEE Std. C37.40™

IEEE Standard Service Conditions and Definitions for High Voltage Fuses, Distribution Enclosed Single-Pole Air Switches, Fuse Disconnecting Switches, and Accessories (ANSI).

IEEE Std. C37.41™

IEEE Standard Design Tests for High-Voltage (>1000V) Fuses, Fuse and Disconnecting Cutouts, Distribution Enclosed Single-Pole Air Switches, Fuse Disconnecting Switches, and Fuse Links and Accessories used with These Devices (ANSI).

IEEE Std. C37.42™

IEEE Standard Specifications for High-Voltage (>1000V) Expulsion-Type Distribution-Class Fuses, Fuse and Disconnecting Cutouts, Fuse Disconnecting Switches, and Fuse Links, and Accessories used with These Devices (ANSI).

IEEE Std. C37.46™

IEEE Standard Specifications for High Voltage Expulsion and Current Limiting Type Power Class Fuses and Fuse Disconnecting Switches.

Contents

Description

Page

Current Limiting Fuse Types	V14-T1-3
Expulsion vs. Current Limiting (Definitions per ANSI C47.40-1993)	V14-T1-3
General Fuse Component Terms	V14-T1-3

Power vs. Distribution

The differentiation is intended to indicate the test conditions and where fuses are normally applied on an electrical system, based on specific requirements for generating sources, substations and distribution lines. Each class has its own unique set of voltage, current and construction requirements (see C37.42, .46 and .47).

Low vs. Medium vs. High Voltage

While fuses are defined in the ANSI standards as either low or high voltage, Eaton has elected to name their fuses to correspond with the equipment in which they are installed. Therefore, per ANSI C84, our fuses are named as follows:

- Low voltage—1000V and below
- Medium voltage—greater than 1000 to 69,000V
- High voltage—greater than 69,000V

IEEE Std. C37.47™

IEEE Standard Specifications for High Voltage Current Limiting Type Distribution Class Fuses and Fuse Disconnecting Switches.

The following IEEE standards are also applicable to the fuse products covered in this publication:

IEEE Std. C37.48™

IEEE Guide for the Application, Operation, and Maintenance of High Voltage Fuses, Distribution Enclosed Single-Pole Air Switches, Fuse Disconnecting Switches, and Accessories (ANSI).

IEEE Std. C37.48.1™

IEEE Guide for the Classification, Application, and Coordination of Current-Limiting Fuses with Rated Voltages 1–38 kV.

A better understanding of some fuse terminology will help you understand and select the correct fuse. The following is a brief overview of those terms.

Expulsion vs. Current Limiting (Definitions per ANSI C47.40-1993)

An expulsion fuse is a vented fuse in which the expulsion effect of the gases produced by internal arcing, either alone or aided by other mechanisms, results in current interruption.

A current limiting fuse is a fuse that, when its current responsive element is melted by a current within the fuse's specified current limiting range, abruptly introduces a high resistance to reduce current magnitude and duration, resulting in subsequent current interruption. Refer to Fuse Types Protection Range figure below for a features comparison.

An expulsion fuse is not current limiting and as a result limits the duration of a fault on the electrical system, not the magnitude.

Current Limiting Fuse Types

There are three current limiting fuse types: Backup, General Purpose and Full Range. It is important that the user have an understanding of these definitions to ensure proper application of the fuse (see Fuse Types Protection Range figure below).

General High Voltage Fuse Comparison

Expulsion	Current Limiting
Vented	Sealed
Electromechanical	Static
Interrupts at current zero	Limits fault current
Generally higher voltage and current application capabilities	Generally higher interrupting ratings
Different time/current characteristics	Different time/current characteristics

Fuse Types Protection Range

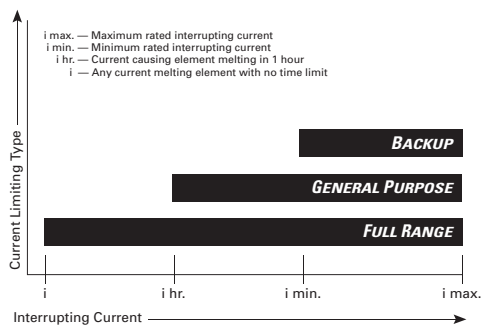

Backup Fuses

A fuse capable of interrupting all currents from the maximum rated interrupting current down to the rated minimum interrupting current.

Backup fuses are always used in a series with another interrupting device capable of interrupting currents below the fuse's minimum interrupting current.

General Purpose Fuses

A fuse capable of interrupting all currents from the rated interrupting current down to the current that causes melting of the fusible element in no less than one hour.

General Purpose fuses are typically used to protect feeders and components such as transformers.

Full Range Fuses

A fuse capable of interrupting all currents from the rated interrupting current down to the minimum continuous current that causes melting of the fusible element, with the fuse applied at the maximum ambient temperature specified by the manufacturer.

General Fuse Component Terms

Fuse Refill Unit (of an Expulsion Fuse)

A fuse refill unit is a replaceable assembly containing the calibrated current-responsive fuse element and certain other items that facilitate current interruption. On its own, the refill unit has no interrupting ability. A refill unit must be mounted in a fuse holder with a spring assembly to form a refillable fuse unit. The refill unit is the section of the fuse that must be replaced after a fuse operation.

Fuse Holder (of an Expulsion Fuse)

A fuse holder is a reusable holder that when equipped with a fuse refill unit forms a fuse unit, capable of interrupting an overload or fault current. A fuse holder is supplied with a spring and shunt assembly, necessary to complete the internal interrupting assembly. The spring and shunt assembly is supplied with the fuse holder but is also available as a replacement part, as it may need replacement after several of heavy operations.

Fuse Unit

A fuse unit is a replaceable unit or assembly that is able, on its own, to perform current interruption. In the case of a refillable fuse unit, the refill unit must be replaced after a fuse operation. Where a complete fuse unit is supplied from the factory, the complete fuse unit must be replaced after a fuse operation. All current-limiting fuses are fuse units.

Exhaust Control Device

When expulsion fuses are used in enclosures, exhaust control devices (filters, condensers or mufflers) are used to control the sound of the fuse operation, and to de-ionize and absorb the fuse exhaust products. These devices are normally supplied separately, because of different characteristics and ratings. They are reusable but may need replacement after several heavy operations.

Mounting

A mounting provides all the necessary parts to safely mount a fuse in its intended piece of equipment. The base is the metal support to which all other pieces attach. Insulators attach to the base and insulate the live fuse unit from the base and everything beyond the base. Live parts are the parts of the mounting that are energized once electricity is flowing. The live parts provide the means to hold the fuse unit in place, electrical contact, and a place to make line and load connections.

Non-Disconnect Mounting

A non-disconnect mounting does not provide a means for removing the fuse unit until the circuit is dead and the fuse unit can be removed manually. The fuse unit is held in place by friction through the use of fuse clips or by a cross bar.

Disconnect Mounting

The disconnect mounting allows the fuse unit to be removed (off load) using an insulated switch stick. The switch stick grabs a pull ring and disconnects the fuse unit that may then be lifted out of its mounting.

Dropout Mounting

Dropout mountings are used in outdoor applications. The fuse unit is equipped with a mechanical trigger that unlatches the upper contact, allowing the fuse unit to drop out, increasing the dielectric separation, and providing visible indication of a blown fuse.

Live Parts

Live parts were briefly discussed as part of the “Mounting” definition. Everything above the insulators on the mounting excluding the fuse unit, fuse holder, and the fuse end fittings (if required) are considered the live parts. Fuse end fittings are discussed next and are not required with non-disconnect live parts, but are required and included with disconnect live parts. Live parts may be sold separately as replacement parts or for new OEM applications.

End Fittings

End fittings are metal parts that attach to each end of a fuse unit’s ferrules (end caps). As previously mentioned, they are used solely with disconnect fuse applications or when converting a non-disconnect to a disconnect fuse configuration.

When end fittings are ordered, a fitting for each end of the fuse is included. Keep in mind that end fittings can become damaged in use and, therefore, are sold separately from the live parts when necessary. It is not necessary to purchase an entire set of live parts when only the end fittings are required.

Eaton Expulsion Fuses



2.1	Product Overview	
	Product Description	V14-T2-2
	Accessories	V14-T2-2
	Catalog Numbers	V14-T2-2
	Refillable and Replaceable Fuses	V14-T2-3
	Outdoor Applications	V14-T2-3
2.2	Fuse Selection	
	Voltage Rating	V14-T2-4
	Interrupting Rating	V14-T2-5
	Continuous Current Rating	V14-T2-7
	Coordination	V14-T2-9
2.3	Application	
	Transformer Application	V14-T2-12
	Repetitive Faults	V14-T2-19
2.4	BA Type Fuses	
	Product Description	V14-T2-20
	Catalog Number Selection	V14-T2-21
	Interrupting Ratings	V14-T2-21
	Product Selection	V14-T2-22
2.5	DBA Type Fuses	
	Product Description	V14-T2-27
	Catalog Number Selection	V14-T2-32
	Interrupting Ratings	V14-T2-32
	Product Selection	V14-T2-33
2.6	DBU Type Fuses	
	Product Description	V14-T2-39
	Construction	V14-T2-39
	Applications	V14-T2-40
	Interruption and Protection	V14-T2-41
	Testing and Performance	V14-T2-43
	Installation	V14-T2-43
	Catalog Number Selection	V14-T2-44
	Interrupting Ratings	V14-T2-44
	Product Selection	V14-T2-45
	Dimensions	V14-T2-50
2.7	RBA and RDB Type Fuses	
	Product Description	V14-T2-52
	Installation	V14-T2-52
	Applications	V14-T2-53
	Operation and Features	V14-T2-53
	Catalog Number Selection	V14-T2-58
	Interrupting Ratings	V14-T2-59
	Product Selection	V14-T2-60
	Dimensions	V14-T2-68

2.1

Expulsion Fuses

Product Overview

Eaton Expulsion Fuses

2



Product Description

Eaton’s expulsion fuses use boric acid as the interrupting medium. Under a fault condition, arc heat decomposes the boric acid into water vapor. The water vapor blast de-ionizes the arc path preventing arc re-ignition after a natural current zero.

RBA type indoor expulsion fuses must be fitted with a discharge filter or condenser, that moderates the discharge exhaust. The discharge filter limits the exhaust to a small and relatively inert amount of gas and lowers the noise level without affecting the fuse interrupting rating. Steam discharge, that can effect the interrupting, is fully restricted by the condenser.

RDB type outdoor dropout fuses include an ejector spring that forces the arcing rod through the top of the fuse. The arcing rod strikes a latch on the mounting that forces the fuse to swing outward through a 180° arc into the dropout position.

Refill units can be field installed into RBA and RDB expulsion fuses. Once the operated unit has been removed, the separately purchased unit can be easily installed into the fuse holder.

DBU type fuse units are designed for new and aftermarket utility applications. End fittings are available, in both indoor and outdoor versions, as well as live parts and mountings. Mufflers confine the arc within the fuse and substantially reduce the noise and exhaust when the fuse interrupts.

RBA E-Rated Refillable Boric Acid



RDB E-Rated Refillable Outdoor Dropout Boric Acid



DBU Dropout Boric Acid— for Use Indoors, Inside Switchgear or Outdoors



Contents

Description

	<i>Page</i>
Catalog Numbers	V14-T2-2
Refillable and Replaceable Fuses	V14-T2-3
Outdoor Applications	V14-T2-3

Accessories

The following accessories are available for expulsion fuses:

Mountings

Mountings include a base, porcelain or glass polyester insulators, and live parts. They help enable the fuse to be safely attached to the gear. Mountings can be either disconnect, non-disconnect or dropout. Non-disconnect mountings are available in bolt-on or clamp-type arrangements. Fuses may be vertical or underhung.

Live Parts

Live parts attach the fuse to the insulators and are considered part of the mounting. All parts above the insulators are live parts.

End Fittings

End fittings are metal parts that attach to each end of the fuse at the ferrules. They are used only on disconnect fuses or when converting a non-disconnect to a disconnect fuse.

Catalog Numbers

Each Eaton fuse product is identified by a unique descriptive catalog number that contains major information such as the fuse family and item, and rated maximum continuous current and rated maximum application voltage where applicable. The catalog number does not change where form, fit and function remain unchanged, although the associated Eaton internal 10 character style number may change. Fuse products should be ordered by the descriptive catalog number.

Refillable and Replaceable Fuses

Boric acid expulsion power fuses are divided into two types, refillable and replaceable.

Refillable fuses are constructed so that the consumable refill unit can be removed and replaced after a fuse operation. Because the fuse holder and spring and shunt assembly components are reused, they can be constructed with a heavy duty design that also allows the unit to have a high interrupting capacity. Because these components are reused it is easy to change fuse current rating by simply changing the refill unit.

The indoor refillable fuse is the RBA (Refillable Boric Acid) fuse. It is designed to be used indoor or in an enclosure with an exhaust control device that limits the discharge given off by the fuse during operation. Three types of exhaust control devices are available to limit the discharge. A condenser may be used that fully restricts the discharge but reduces the interrupting

rating. A discharge filter is available that restricts discharge but not to a level that causes a reduction in the interrupting rating. A high capacity discharge filter is also available, but its use is restricted to certain applications on 15.5 kV equipment at maximum voltages below 14.4 kV. This device allows a higher interrupting rating, but allows more discharge.

The outdoor refillable fuse is the RDB (Refillable Dropout Boric acid) fuse. RDB fuses cannot be equipped with exhaust control devices.

The construction of the RDA and RDB is similar. They both utilize RBA refill units. The main difference in the internal construction is the ballistic kick-out pin that initiates the dropout action. Externally the RBD outdoor fuse holder tube has a protective coating of tough epoxy paint that provides ultraviolet protection. The fuse holder has a sealed weatherproof design.

A complete fuse consists of a fuse mounting, a fuse holder that includes the spring and shunt assembly, a refill unit, and an exhaust control device for indoor applications. These parts are shown in the RBA/RDB section.

Both disconnect and non-disconnect mountings are available for RBA fuses. Each of these mountings has front connected terminals. Indoor non-disconnect fuse holders have translucent tubes, and the lower end of the spring and shunt assembly is equipped with a bright orange cap to give a visual indication of fuse operation. RDB outdoor mountings must be disconnecting because of the dropout requirement to provide dielectric isolation and visible indication.

BA type installations were made obsolete several years ago, but BA refill units are still available to enable re-fusing in existing applications. BA and RBA installations use the same exhaust control devices. RBA filters or condensers can be used to replace BA filters or condensers if required. Replacement BA mountings and fuse holders are not normally available.

Replaceable fuses have a lower initial installed cost by providing a more cost effective construction. Replaceable fuses generally offer faster reconnection, but with higher replacement cost and lower interrupting ratings.

Eaton offers a replaceable style DBU fuse for either indoor or outdoor applications. DBU fuses are lighter, less expensive fuses than the higher rated RBA/RBD fuses. DBA fuse units are offered as replacement fuses, but DBA mountings are no longer available.

Outdoor Applications

For outdoor application of the RDB, DBU and DBA fuses, it is important that fuses that have not operated are not left hanging in the disconnected position for extended periods. If the weather seals on these fuses are broken or damaged, it is possible for water to enter and damage the fuse unit or fuse refill unit. The integrity of these seals is directly related to the integrity of the fuse unit or fuse refill unit. Seals should be checked periodically and an affected fuse unit or fuse refill unit replaced. The condition of the paint on the fuse unit should also be checked periodically.

Eaton expulsion fuses use boric acid for the interrupting medium. When the fuse element melts, the heat of the arc decomposes the boric acid, releasing water vapor that cools and extinguishes the arc by blasting through it and exiting the bottom of the fuse. The interruption process produces both a flow of exhaust gas and a good deal of noise. To moderate the pressure wave and noise, an exhaust control device is added to indoor fuses. Exhaust control devices limit the exhaust to a small and relatively inert amount of gas while lowering the noise level, but have little or no effect on the interrupting rating of the fuse. Mufflers and condensers absorb and contain the exhaust while drastically reducing the noise level; however, a condenser or muffler may cause a reduction of the interrupting rating of the fuse.

Typical Discharge Pattern from an Eaton Outdoor Boric Acid Power Fuse

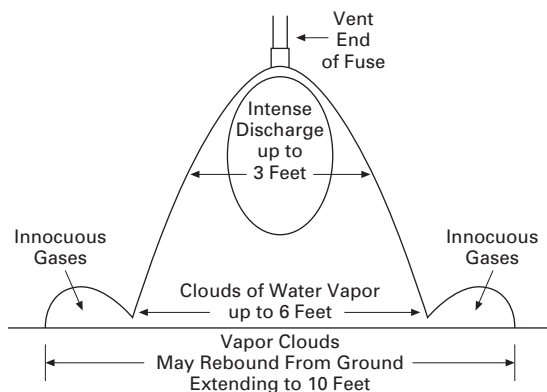

DBU Outdoor Mounting

2



Fuse Selection

There are four factors involved in the selection of a boric acid expulsion fuse.

The first three considerations are the rated maximum voltage, the rated maximum interrupting current including the rate of rise of the transient recovery voltage, and the rated continuous current of the fuse. Proper attention must be given to each of these as improper application in any one of these areas may result in the fuse failing to perform its intended function. The fourth consideration is coordination with line and load side protective equipment that is needed to give selectivity of outage and to prevent premature operation.

Each of these four areas is discussed in detail.

Voltage Rating

The first consideration regarding fuse application is that the fuse selected must have a rated maximum voltage equal to or greater than the maximum power frequency voltage that could be impressed across the fuse under any possible conditions. In most cases, this means that the rated maximum voltage of the fuse must equal or exceed the system maximum line-to-line voltage. The only exception to this rule occurs when fusing single-phase loads connected from line-to-neutral on an effectively grounded four-wire system. Here, the fuse rated maximum voltage need only exceed the system maximum line-to-neutral voltage, providing it is impossible for the fuse to experience the full

Contents

Description

	<i>Page</i>
Fuse Selection	
Interrupting Rating	V14-T2-5
Continuous Current Rating	V14-T2-7
Coordination	V14-T2-9

line-to-line voltage under any fault condition. A good rule of thumb is that if more than one phase of the system is extended beyond the fuse location, the fuse rated maximum voltage must equal or exceed the system maximum line-to-line voltage, regardless of how the three-phase system is grounded on the source side of the fuse or how the transformers or loads are connected on the load side of the fuse. It is a fairly common practice to fuse wye grounded wye transformers with fuses that have a rated maximum voltage that only exceeds then system line-to-neutral voltage. In most cases, this presents no problem, but the user should be aware of the remote possibility of a

secondary phase-to-phase fault that could impose full line-to-line voltage across a single fuse. When only one phase of a four-wire effectively grounded system is extended beyond the fuse location to supply a load connected from phase-to-neutral, it is usually acceptable to have the fuse rated maximum voltage equal or exceed the maximum line-to neutral voltage.

It is permissible for expulsion fuse rated voltage to exceed the system voltage by any desired amount but under no circumstances may the system maximum voltage exceed the fuse rated maximum voltage.

Interrupting Rating

Under no circumstance should a fuse be applied in a situation where the available fault current exceeds the interrupting rating of the fuse.

The rated maximum interrupting current of a boric acid expulsion fuse is the rms value of the symmetrical AC component of the highest current that the fuse has been demonstrated to be able to interrupt under any conditions of asymmetry with specified circuit conditions. In other words, the rated maximum interrupting current denotes the maximum symmetrical fault current permitted at the fuse location. Historically, boric acid expulsion fuses have alternately been rated in terms of asymmetrical fault current. Asymmetrical currents are related to symmetrical currents by the asymmetry factor, which is the ratio of the rms values of the asymmetrical and symmetrical currents. The asymmetrical current includes the decaying DC component of the fault current. Asymmetry factors are a function of the circuit X/R ratio, and this relationship is shown below. Theoretically, the maximum asymmetry factor in a purely inductive circuit 1.732; however, with X/R ratios encountered in power circuits, it is rarely ever more than 1.6. Fuse standards suggest an asymmetry factor of 1.56 to 1.6. The minimum

asymmetry factor at which Eaton boric acid expulsion fuses are tested to determine their rated maximum interrupting current is 1.6. In general, historically stated asymmetrical rms rated maximum interrupting currents can be converted to their rms symmetrical rated maximum counterparts by dividing the asymmetrical value by 1.6.

Historically, a third way to state the interrupting rating of a boric acid expulsion fuse was with nominal three-phase kVA ratings. Three-phase kVA ratings are calculated by the formula $kVA = I \times kV \times 1.732$, where I is the rated maximum interrupting current in symmetrical rms amperes and kV is the fuse nominal voltage rating. With this method, it must be kept in mind that fuses are not constant kVA devices, that is, if the voltage is half the fuse rating, the interrupting current does not double but remains the same. The fuse will interrupt any current up to the rated maximum interrupting current as long as the power frequency voltage does not exceed the rated maximum voltage of the fuse.

Interrupting ratings for each type of Eaton expulsion fuse are listed in the detailed sections for each fuse type.

Asymmetry Factors

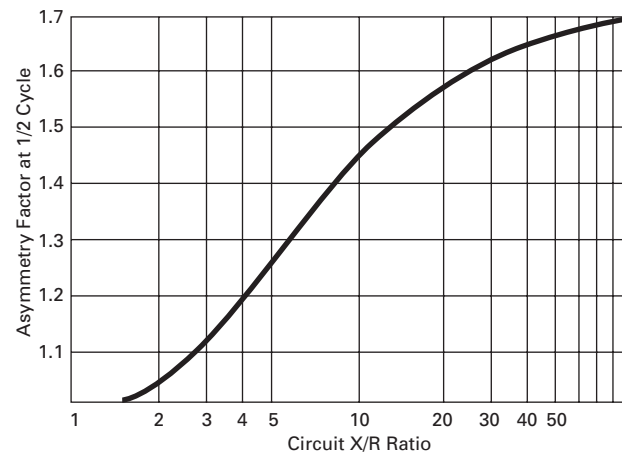

When the fusible element in an expulsion fuse melts as the result of a fault, an arc is established within the fuse. Normal operation of an expulsion fuse causes elongation of the arc due to spring tension. The current continues to flow in the circuit and within the fuse until a natural current zero of the circuit is reached. When the arc is extinguished at a current zero, the voltage across the fuse terminals changes abruptly from a relatively low value of arc voltage to the power frequency recovery voltage. The rapid voltage change, in association with the inherent capacitance in the circuit, causes a short duration high frequency voltage oscillation to be superimposed on the power frequency recovery

voltage. This combination of power frequency voltage and high frequency oscillatory voltage is known as the Transient recovery voltage. Transient recovery voltages produce high voltage stresses across the fuse terminals. The dielectric strength between the fuse terminals must rise faster than the transient recovery voltage if a successful interruption is to occur. The natural frequency of the transient recovery voltage is determined by the circuit inductance and capacitance, and the amplitude and decay rate are determined by the circuit resistance. The peak factor is the ratio of the highest (first) peak of the transient recovery voltage to the power frequency recovery voltage.

2.2

Expulsion Fuses

Fuse Selection

2

Primary faults, or faults on the primary side of a transformer, will generally produce higher short-circuit currents and less severe transient recovery voltages. Secondary faults produce lower fault currents and more severe transient recovery voltages. This is due to the insertion of the transformer impedance in the circuit. Eaton recognizes the effects of the different parameters involved in primary and secondary fault phenomena. These various conditions are

also reflected in the test parameters called for in IEEE Std. C37.41-2000™. Eaton's line of expulsion fuses have proven their ability to successfully withstand the transient recovery voltage associated with both types of faults. The table on **Page V14-T2-6** lists the frequency of the transient recovery voltage and amplitude factors at which these fuses were tested. These conditions meet or exceed the requirements of the ANSI Standards.

Another consideration when applying power fuses is the altitude at which they are installed. The dielectric strength of air decreases with increasing altitude. De-rating is required for applications at altitudes above 1000 meters (3300 feet). Correction factors for various altitudes are listed in IEEE Std. C37.40™.

Fuses are fault protective devices, and are overload tolerant not overload protective devices. By design, power type expulsion

fuses are not intended to operate on fault currents below the secondary terminal fault of the associated transformer. Distribution type expulsion fuses can be used where the protection requirements call for a greater degree of overload protection. However, E-rated and K-rated fuses do not provide protection for fault currents less than two times the continuous current rating of the fuse.

Transient Recovery Voltage Values for RBA, RDB and DBU Fuses

Voltage kV		Transient Recovery Voltage Values			
Nominal	Maximum Design	Primary Fault Recovery		Secondary Fault Recovery	
		Frequency in kHz	Amplitude Factor	Frequency in kHz	Amplitude Factor
2.40	2.75	9.0	1.6	26.0	1.6
4.16	4.80	9.0	1.6	26.0	1.6
4.80	5.50	9.0	1.6	26.0	1.6
7.20	8.25	9.0	1.6	26.0	1.6
13.80	14.40	5.5	1.6	17.4	1.6
14.40	15.50	5.5	1.6	17.4	1.6
23.00	25.50	4.2	1.6	13.0	1.6
34.50	38.00	3.9	1.6	8.5	1.6

Continuous Current Rating

Eaton's expulsion fuses are designed to carry rated current continuously without exceeding the temperature and temperature rise limits permitted by IEEE Std. C37.40™-2003 when tested as specified in IEEE Std. C37.41™-2000. The ranges of continuous current ratings available in Eaton's fuses are shown in the table below. These current ratings carry either an E or a K designation as defined in ANSI C37.42-1996 or ANSI C37.46-2000.

The current responsive element of a power fuse with a continuous current rating of 100E or below shall melt in 300 seconds at an rms current between 200% and 240% of the continuous current rating.

The current responsive element of a power fuse with a continuous current rating of above 100E shall melt in 600 seconds at an rms current between 220% and 264% of the continuous current rating.

The current responsive element of a distribution fuse with a K designation on the current rating shall melt within the required time ranges specified for various current levels in Table 8 of ANSI C37.42-1996.

Although the E and K ratings do not make time current curves identical, they do produce a similarity among different manufacturer's fuses, as they all must satisfy the same requirements. The E and K ratings also reflect the 2:1 minimum melting current versus continuous current rating that is a design feature of these fuses.

Note that this similarity between the time current curves of E-rated expulsion fuses from various manufacturers does not imply that the time current curves of E-rated expulsion and current limiting fuses are similar even from the same manufacturer—there are in fact, considerable differences, and this must be considered when comparing expulsion and current-limiting fuses.

Power fuses are designed to continuously carry their rated current without exceeding temperature rise restrictions. If rated current is exceeded enough to cause the temperature or temperature rise limits to be exceeded, but the current is still below the 300 or 600 second melting current for a considerable length of time, a large amount of heat will be generated that may cause permanent damage to the fuse. Even though the DBU and RBA/RDB standard fuses employ silver elements that are not subject to thermal degradation unless the element temperature nearly reaches the melting temperature, caution should still be exercised when overloading the fuse as prolonged overheating will cause deterioration of the boric acid interrupting medium and charring of the fuse wall before the fuse element melts. The following curve shows the overload characteristics of Eaton's expulsion fuses. Do not exceed these overload restrictions under any circumstances.

In practice, expulsion power fuses are used to protect transformers and other equipment where overloads and inrush currents are common. As boric acid expulsion fuses have a rather low thermal capacity and cannot carry overloads of the same magnitude and duration as motors and transformers of equal continuous currents, general fuse application ratio of 1.4:1 fuse continuous current rating to full load current is suggested to prevent nuisance fuse operations on acceptable overloads and inrush conditions. Remember that this is only a general ratio for typical applications, and that ratios as low as 1:1 or as high as 2:1 can be used for specific applications. More specific application information can be found in the individual equipment applications sections that follow.

Continuous Current Ratings Available in Eaton Expulsion Fuses

Maximum Design kV	RBA-RDB-200 Standard	RBT-200 Time Lag	RBA-RDB-400 Standard ①	RBT-400 Time Lag	DBU Standard	DBU Slow	DBU K-Rated	DBA-1, 2 Standard
2.75	10E to 200E	20E to 200E	0.5E to 400E1	20E to 400E1	—	—	—	—
5.50	10E to 200E	20E to 200E	0.5E to 400E1	20E to 400E1	—	—	—	—
8.25	10E to 200E	20E to 200E	0.5E to 400E1	20E to 400E1	—	—	—	0.5E to 200E
14.40	10E to 200E	20E to 200E	0.5E to 400E1	20E to 400E1	5E to 200E	15E to 200E	3K to 200L	0.5E to 200E
15.50	10E to 200E	20E to 200E	0.5E to 400E1	20E to 400E1	5E to 200E	15E to 200E	3K to 200L	0.5E to 200E
25.50	10E to 200E	20E to 200E	0.5E to 300E2	20E to 300E2	5E to 200E	15E to 200E	3K to 200L	0.5E to 200E
38.00	10E to 200E	20E to 200E	0.5E to 300E2	20E to 300E2	5E to 200E	15E to 200E	3K to 200L	0.5E to 200E

Note

① Using the two paralleled 800 fuse design, which has a 10% derating factor, ratings of 450, 540 and 720 are available.

Overload Characteristics for Eaton Expulsion Fuses

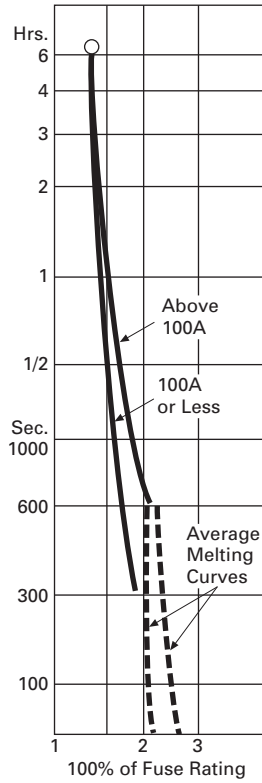

Eaton’s expulsion type fuses must not be paralleled to obtain continuous current ratings greater than those indicated, with the exceptions stated below. Satisfactory operation of untested parallel arrangements cannot be predicted.

RBA-8, RDB-8 and BA-8 assemblies have been specifically tested to demonstrate their correct operation throughout the rated range of interrupting currents, with the specific physical arrangements shown.

Corrections for applying expulsion fuses above 3300 feet also apply to the continuous current ratings as well as the interrupting rating. De-rating is required for applications at altitudes above 1000 meters (3300 feet). Correction factors for various altitudes are listed in IEEE Std. C47.40™.

Remember that:

- Under no circumstances must the continuous rating of the fuse be less than the continuous load current
- E-rated fuses do not provide protection for currents below two times the continuous current rating

Coordination

In addition to selecting a fuse that meets the voltage, interrupting and continuous current ratings, it is important to examine the time-current curves of the fuse. These curves are designated as minimum melt and total clearing curves. The minimum melt curve gives the minimum amount of time in seconds required to melt the fuse elements at a particular value of rms symmetrical current under specified conditions. The total clearing curve gives the maximum amount of time in seconds to complete interruption of the circuit at a particular value of rms symmetrical current under conditions specified in ANSI C37.42-1996 or ANSI C36.46-2000.

The time-current curves for Eaton fuses are derived from tests on fuses at an ambient temperature of 25 degrees C and no initial loading as specified in IEEE Std. C37.46™.

Arcing time is defined as the amount of time in seconds elapsing from the melting of the fusible element to the final interruption of the circuit. It is important to examine these characteristics to assure proper protection and selectivity with other overcurrent protective devices. These curves are located in each fuse section of the catalog.

The melting curves of all E-rated fuses must lie within the range defined in IEEE Std. C37.46™ at either the 300 or 600 second point, but there are no limitations placed on the melting time at high currents. To take advantage of this, Eaton increases the applicability of their fuses by producing fast or standard fuses and slow or time-lag fuses. The curves for time-lag fuses are less inverse and allow for more of a time delay at high currents.

The melting curves of all K-rated DBU fuses must lie within the ranges defined in IEEE Std. C37.42™.

Proper coordination of power fuses requires keeping the minimum melting current time-current curve above the total clearing time-current curve of any downstream protective device, and keeping the total clearing time-current curve beneath the minimum melting time-current curve of any upstream protective device. Manufacturers publish time-current curves based on standard conditions that do not allow for variables such as pre-loading or ambient temperature. Fuses subject to conditions other than the above will experience shifts in the time-current curves.

For this reason, it is recommended that a safety zone be used to ensure that proper coordination is maintained allowing for these variables. Eaton recommends the use of a 10% safety zone on current for a particular value of time as it allows the safety band to be published on the left-hand side of all the time-current curves. Coordination is then achieved by overlaying curves and shifting one by the width of the published safety zone.

Although the relevant ANSI and IEEE standards allow a 20% tolerance band on current between minimum and maximum melting characteristics, Eaton published characteristics in general only show a 10% tolerance band that can be seen for times greater than 0.5 second. Note that the published upper limit time-current curve is for total clearing, and not maximum melting. The total clearing time-current curve gives the maximum melting time plus the arcing time of the fuse.

If desired or if unusual conditions exist, shifts in the time-current curve due to pre-loading may be examined individually. The following illustration gives the adjusting factor for preloaded fuses. These adjusting factors are valid only for Eaton power fuses.

Preloading Adjustment Factor for Eaton Expulsion Fuses

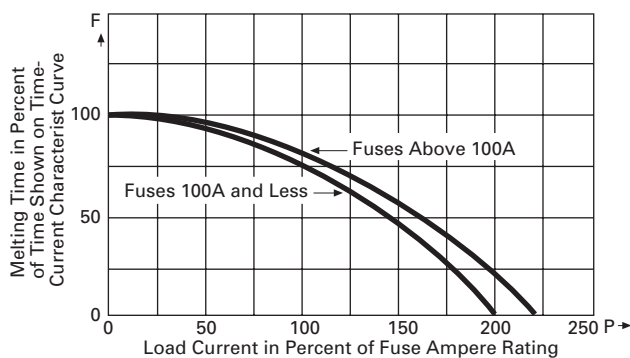

2.3

Expulsion Fuses

Application

RBA Fuses

2



Application

Use of the current generation of protection and coordination computer programs has taken much of the hard work out of checking coordination between medium voltage fuses and the upstream and downstream devices and protective equipment in the circuit. In addition, they allow detailed analysis of potential arc flash that could occur due to faults at particular circuit locations. Additional considerations such as the effects of cable run lengths can also be included in the fault current calculations to increase the accuracy of coordination and arc flash studies. However, a basic understanding of the coordination principles behind such studies is necessary for correct interpretation of the results.

When applying expulsion fuses, physical as well as electrical properties must be considered. Expulsion fuses emit gases from the bottom of the fuse and as a result, care should also be taken to maintain minimum phase-to-phase and phase-to-ground clearances when mounting fuses. Indoor fuses employ an exhaust control device, a discharge filter, a muffler or a condenser to absorb some or most of the exhaust from the fuse but specified clearances must still be maintained.

Contents

Description

Page

Application	
Transformer Application	V14-T2-12
Repetitive Faults	V14-T2-19
Repetitive Faults	V14-T2-19

Outdoor fuses are vented and thus have a high noise level and expel a greater amount of gas making clearance from ground an important consideration. However, the noise level of outdoor power fuses that employ boric acid solid material to control the arcing process is generally much lower, and the exhaust column is less violent than that associated with fuses employing links and cutouts, even at higher levels of interrupting current. When applying outdoor fuses, clearance must also be allowed for the arc that the fuse swings through during dropout. The tables on **Page V14-T2-11** give the minimum clearance to ground and the minimum phase spacing.

Outdoor fuses are vented, and the venting of the hot gases resembles a cylindrical or narrowly conical column height above the minimum ground clearance. It is not really a factor except as related to rebounding from the ground of hot particles and gases. The illustration on **Page V14-T2-3** shows the nature of the discharge and allows the user to suggest specific safety zones for each particular application.

Recommended Spacings—Typical Single Fuse Unit

Typical Filter or Condenser

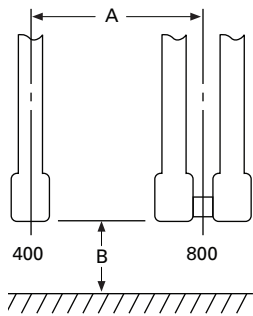

Typical Vented

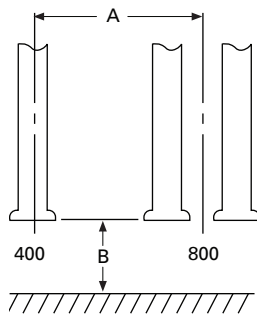

Typical paralleled fuse unit with standard Eaton mounting.

Legend

- A** = Recommended phase-to-phase centerline spacing without barriers
- B** = Minimum clearance to ground

(A) Recommended Phase-to-Phase Centerline Spacing without Barriers in Inches

Maximum Design kV	RBA Disconnect		RBA Non-Disconnect		RDB		DBU	DBA
	200/400	800	200/400	800	200/400	800		
2.75	11.75	27.51	11.16	19.92	19.0	26.76	17.0	17.0
4.80	11.75	27.51	11.16	19.92	18.0	26.75	17.0	17.0
5.50	11.75	27.51	11.16	19.92	18.0	26.75	17.0	17.0
8.25	13.25	29.01	12.56	21.32	18.0	26.76	17.0	17.0
14.40	14.75	30.51	13.06	21.82	24.0	32.76	19.0	19.0
15.50	16.25	32.01	15.56	24.32	24.0	32.76	19.0	19.0
25.50	20.25	—	19.56	—	30.0	38.76	23.0	23.0
38.00	25.25	—	24.56	—	36.0	44.76	30.0	30.0
48.30	—	—	—	—	—	—	—	33.0
72.50	—	—	—	—	—	—	—	44.0

(B) Minimum Clearance to Ground in Inches

Maximum Design kV	RBA Filter	RBA Condenser	RDB-200, DBU and DBA-1 Vented	RDB-400, 800 and DBA-2 Vented
	2.75	7.5	3.0	17.5
4.80	7.5	3.0	17.5	22.0
5.50	8.5	4.0	17.5	22.0
8.25	8.5	4.0	17.5	22.0
14.40	11.5	6.0	21.0	26.0
15.40	11.5	6.0	21.0	26.0
25.50	15.0	8.5	26.0	32.0
38.00	19.5	12.0	33.0	42.0
48.30 (DBA only)	—	—	40.0	54.0
72.50 (DBA only)	—	—	54.0	84.0

Transformer Application

Fuses are installed on the primary side of a transformer to:

- Protect the system on the source side of the fuses from an outage due to faults in or beyond the transformer (isolate a faulted transformer from an otherwise healthy distribution system to prevent further disturbance)—in the case of an internal winding fault in the transformer, the fuse should prevent further collateral damage to the transformer and its surroundings (although the primary fuses will isolate a transformer with an internal fault from the primary system, expulsion fuses generally are not fast enough to prevent extensive damage to the transformer)
- Coordinate with protection on the low-voltage side of the transformer (transformer primary protection must be overload tolerant, allowing the secondary protection to clear faults occurring downstream of the secondary protection)
- Protect the transformer against bolted secondary faults (the fuse should operate on any bolted secondary faults, between the transformer secondary terminals and the secondary protection before the transformer is damaged—usually thru-fault protection is provided to the transformer by a main secondary breaker or breakers and the main purpose of the primary fuses is to isolate a faulted transformer from the primary system)
- Protect the transformer against higher impedance secondary faults to whatever extent is possible (the fuse should limit damage to the transformer windings to the best extent possible)

Selecting the proper voltage, interrupting and continuous current ratings for the fuse is straightforward and has been sufficiently covered in their respective sections.

There are two sometimes conflicting factors when selecting a fuse to protect a transformer circuit. The continuous current rating must be large enough to prevent premature fuse interruption from magnetizing or inrush currents and it must also be large enough to prevent fuse deterioration or fuse interruption during normal or emergency overload situations. The fuse rating must also be small enough to provide the protection listed in the purpose hierarchy.

Fuses on the primary side of transformers should not operate on transformer magnetizing or inrush current. The magnitude of the first loop of inrush current and the rate at which the peaks of subsequent loops decay is a function of many factors. Some of these are transformer design, residual flux in the core at the instant of energization, the point on the voltage wave at which the transformer is energized and the characteristics of the source supplying the transformer. When energizing, the heating effect of the inrush current can be considered equal to 12 times the transformer full load current for 1/10 of a second. Thus, when selecting the current rating for fuses used at the primary side of a transformer, the fuse minimum melting curve must lie above and to the right of the point on the time-current curve representing 12 times full load current and 0.1 seconds. The fuse whose minimum melting curve lies just above and to the right of this point is the lowest rated fuse that can be used at the primary terminals to satisfy the inrush requirements. This criterion is normally satisfied for all Eaton expulsion fuses if the fuse current rating is equal to or greater than the transformer self-cooled full load current. Thus, a fusing ratio as low as 1:1 could be used in selecting primary side fuses if inrush or magnetizing current were the only concern.

Typical Fuse—Transformer Coordination

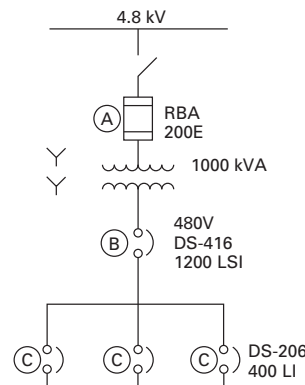
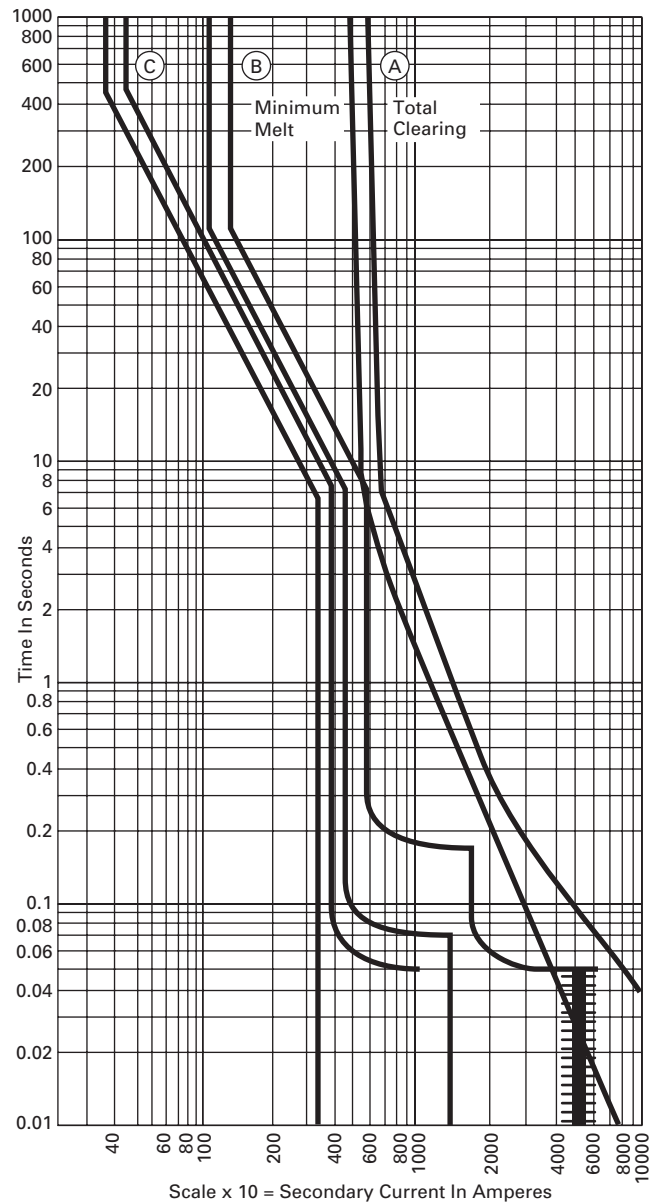

Breaker	LD		SD		I	
	Amps	PU	T	PU	T	PU
BDS-416	1200	IX	4 sec	4X	0.18 sec	12X
CCDS-206	400	IX	20 sec	—	—	9X

System operators frequently overload their transformers for short periods of time during normal and emergency situations. To allow this flexibility, it is necessary to select a fuse that can carry the overload without deteriorating. To accommodate these overloads, a fusing ratio higher than 1:1 is almost always required when applying fuses for transformer protection. The fuse emergency overload curve on **Page V14-T2-8** along with the required extent of overloading is used to determine the smallest fuse that can be applied. Determine the minimum fuse rating by using the duration (ordinate) of the transformer overload on the fuse overload curve on **Page V14-T2-8** to obtain the multiple of the current rating that should not be exceeded.

Divide the transformer overload current by the multiple obtained from the overload curve. The result is the minimum fuse current rating. Select the fuse rating that equals or is just larger than this value. The allowable time duration of the current in the primary side fuses during transformer overload should never exceed the values shown by the fuse overload curve on **Page V14-T2-8**.

Note: Short term and long term overloading of transformers will adversely affect the service life of the transformer. Also, increasing the primary fuse size to allow for higher overloads decreases the protection afforded the transformer. The extent to that transformers are overloaded and the implications for system security are economic decisions that are made by the system operator.

Suggested minimum fuse sizes for protection of self-cooled transformers are given in the tables on **Pages V14-T2-14** and **V14-T2-15**. These tables are based on the premise that the maximum 1.5 hour overload on the transformer would not exceed 200 percent of the transformer rating. This overload condition requires that the minimum ratio of fuse current rating to transformer full load current is 1.4:1. Fuse sizes listed in the tables on **Pages V14-T2-14** and **V14-T2-15** are those that are just higher than 1.4 times the transformer full load current. If higher or longer duration transformer overloads are to be permitted, a fuse with a higher continuous current rating may be required. The procedure described above should then be used to find the smallest permissible fuse size.

Suggested Minimum Expulsion Fuse Current Ratings

2

Self-Cooled 2.4 to 12.0 kV Power Transformer Applications

Nominal kV	2.4	2.4	4.16	4.16	4.8	4.8	7.2	7.2	12.0	12.0
Fuse Maximum kV	8.3	8.3	8.3	8.3	8.3	8.3	8.3	8.3	15.5	15.5
Transformer Full kVA Rating Self-Cooled	Full Load Current Amps	Fuse E-Ampere Rating	Full Load Current Amps	Fuse E-Ampere Rating	Full Load Current Amps	Fuse E-Ampere Rating	Full Load Current Amps	Fuse E-Ampere Rating	Full Load Current Amps	Fuse E-Ampere Rating
Three-Phase Transformers										
9	2.16	3E	1.25	3E	1.10	3E	0.72	3E	0.43	3E
15	3.60	5E	2.08	3E	1.80	3E	1.20	3E	0.72	3E
30	7.20	10E	4.20	7E	3.60	5E	2.40	5E	1.44	3E
45	10.80	15E	6.20	10E	5.40	10E	3.60	5E	2.16	3E
75	18.00	25E	10.40	15E	9.00	15E	6.00	10E	3.60	5E
112	27.00	40E	15.60	25E	13.60	20E	9.00	15E	5.40	10E
150	36.00	50E	20.80	30E	18.00	25E	12.00	20E	7.20	10E
225	54.00	80E	31.30	50E	27.20	40E	18.00	25E	10.80	15E
300	72.00	100E	41.60	65E	36.00	50E	24.00	40E	14.40	20E
500	120.00	200E	69.40	100E	60.00	100E	40.00	65E	24.10	40E
750	180.00	250E	104.00	150E	90.00	125E	60.00	100E	36.10	50E
1000	241.00	400E	140.00	200E	120.00	200E	80.00	125E	48.10	80E
1500	360.00	540E ^①	208.00	300E	180.00	250E	120.00	200E	72.00	100E
2000	481.00	720E ^②	278.00	400E	241.00	400E	160.00	250E	496.20	150E
2500	600.00	—	346.00	540E ^①	301.00	450E ^③	200.00	300E	120.00	200E
3750	—	—	—	—	—	...	—	—	180.00	250E
5000	—	—	—	—	—	...	—	—	241.00	400E
Single-Phase Transformers										
5	2.08	3E	1.20	3E	1.04	3E	0.69	3E	0.416	3E
10	4.17	7E	2.40	5E	2.08	3E	1.39	3E	0.832	3E
15	6.25	10E	3.60	5E	3.13	5E	2.08	3E	1.25	3E
25	10.40	15E	6.00	10E	5.20	10E	3.47	5E	2.08	3E
37	15.60	25E	9.00	15E	7.80	15E	5.21	10E	3.12	5E
50	20.80	30E	12.00	20E	10.40	15E	6.95	10E	4.16	7E
75	31.30	50E	18.00	25E	15.60	25E	10.40	15E	6.25	10E
100	41.70	65E	24.00	40E	20.80	30E	13.90	20E	8.32	15E
167	70.00	100E	40.00	65E	35.00	65E	23.20	40E	13.90	20E
250	104.00	150E	60.00	100E	52.00	80E	34.80	50E	20.80	30E
333	139.00	200E	80.00	125E	69.50	100E	46.30	65E	27.70	40E
500	208.00	300E	120.00	200E	104.00	150E	69.60	100E	41.60	65E
667	278.00	400E	160.00	250E	139.00	200E	92.60	150E	55.40	80E
833	347.00	540E ^①	200.00	300E	173.00	250E	115.50	200E	69.40	100E
1250	521.00	720E ^②	300.00	540E ^①	260.00	400E	174.00	250E	104.00	150E

Notes

- ① Two (2) 300E ampere fuse refills used in parallel with 10% derating factor.
 ② Two (2) 400E ampere fuse refills used in parallel with 10% derating factor.
 ③ Two (2) 250E ampere fuse refills used in parallel with 10% derating factor.

Self-Cooled 13.2 to 34.5 kV Power Transformer Applications

System Nominal kV	13.2	13.2	13.8	13.8	14.4	14.4	22.9	22.9	23.9	23.9	24.9	24.9	34.5	34.5
Fuse Maximum kV	15.5	15.5	15.5	15.5	15.5	15.5	25.5	25.5	25.5	25.5	25.5	25.5	38.0	38.0
Transformer Full kVA Rating Self-Cooled	Full Load Current Amps	Fuse E-Ampere Rating	Full Load Current Amps	Fuse E-Ampere Rating	Full Load Current Amps	Fuse E-Ampere Rating	Full Load Current Amps	Fuse E-Ampere Rating	Full Load Current Amps	Fuse E-Ampere Rating	Full Load Current Amps	Fuse E-Ampere Rating	Full Load Current Amps	Fuse E-Ampere Rating
Three-Phase Transformers														
9.00	0.40	3E	0.38	3E	0.36	1/2E	0.22	1/2E	0.21	1/2E	0.20	1/2E	0.15	1/2E
15.00	0.66	3E	0.62	3E	0.60	3E	0.38	3E	0.36	1/2E	0.35	1/2E	0.25	1/2E
30.00	1.32	3E	1.25	3E	1.20	3E	0.75	3E	0.72	3E	0.69	3E	0.50	3E
45.00	1.98	3E	1.88	3E	1.80	3E	1.14	3E	1.09	3E	1.04	3E	0.75	3E
75.00	3.30	5E	3.10	5E	3.00	5E	1.89	3E	1.81	3E	1.74	3E	1.25	3E
112.50	4.95	7E	4.70	7E	4.51	7E	2.84	5E	2.72	5E	2.60	5E	1.88	3E
150.00	6.56	10E	6.20	10E	6.01	10E	3.78	7E	3.62	5E	3.47	5E	2.51	5E
225.00	9.90	15E	9.40	15E	9.02	15E	5.68	10E	5.44	10E	5.21	10E	3.77	7E
300.00	13.10	20E	12.50	20E	12.00	20E	7.58	15E	7.25	10E	6.94	10E	5.02	7E
500.00	21.90	30E	21.00	30E	20.10	30E	12.60	20E	12.10	20E	11.60	20E	8.37	15E
750.00	32.80	50E	31.00	50E	30.10	50E	18.90	30E	18.10	25E	17.40	25E	12.60	20E
1000.00	43.70	65E	42.00	65E	40.10	65E	25.30	40E	24.20	40E	23.10	40E	16.70	25E
1500.00	65.60	100E	62.00	100E	60.10	65E	37.90	65E	36.20	50E	34.70	50E	25.10	40E
2000.00	87.50	125E	84.00	125E	80.20	125E	50.50	80E	48.30	80E	46.30	65E	33.50	50E
2500.00	109.00	150E	104.00	150E	100.00	150E	63.10	100E	60.40	100E	57.90	80E	41.80	65E
3750.00	165.00	250E	156.00	250E	150.00	250E	94.70	150E	90.60	150E	86.60	125E	62.80	100E
5000.00	218.00	300E	210.00	300E	200.00	300E	126.00	200E	121.00	200E	116.00	200E	83.70	125E
Single-Phase Transformers														
5.00	0.38	3E	0.36	3E	0.35	1/2E	0.22	1/2E	0.21	1/2E	0.20	1/2E	0.14	1/2E
10.00	0.76	3E	0.72	3E	0.69	3E	0.44	3E	0.42	3E	0.40	3E	0.29	1/2E
15.00	1.14	3E	1.09	3E	1.64	3E	0.66	3E	0.63	3E	0.60	3E	0.43	3E
25.00	1.90	3E	1.81	3E	1.74	3E	1.09	3E	1.05	3E	1.00	3E	0.72	3E
37.50	2.84	5E	2.71	5E	2.60	5E	1.64	3E	1.57	3E	1.50	3E	1.09	3E
50.00	3.80	7E	3.62	5E	3.47	5E	2.19	3E	2.09	3E	2.00	3E	1.45	3E
75.00	5.70	10E	5.43	10E	5.21	10E	3.28	5E	3.14	5E	3.01	5E	2.17	3E
100.00	7.60	15E	7.24	10E	6.94	10E	4.37	7E	4.18	7E	4.01	7E	2.90	5E
167.00	12.70	20E	12.10	20E	11.60	20E	7.31	10E	6.99	10E	6.70	10E	4.84	7E
250.00	19.00	30E	18.10	25E	17.40	25E	10.90	15E	10.50	15E	10.00	15E	7.25	10E
333.00	27.70	40E	25.20	40E	23.10	40E	14.60	20E	13.90	20E	13.40	20E	9.65	15E
500.00	38.00	65E	36.20	50E	34.70	50E	21.90	30E	20.90	30E	20.10	30E	14.50	20E
667.00	50.50	80E	48.20	80E	46.30	65E	29.20	40E	27.90	40E	26.80	40E	19.30	30E
833.00	63.50	100E	60.40	100E	57.90	80E	36.40	50E	34.90	50E	33.40	50E	24.10	40E
1250.00	95.00	150E	90.60	125E	86.80	125E	54.70	80E	52.30	80E	50.10	80E	36.20	50E

If provisions are made to limit transformer overloads to a lower range, by thermal or other protective devices, the ratio of fuse current to transformer full load current can be less than 1.4:1. To find the amount of reduction permissible without damage to the fuse, the procedure using the overload curve should be employed.

When the transformer has forced cooling, the minimum fuse size that can be applied should be based on the transformer top rating and the extent to which the transformer will be overloaded beyond the top rating.

It should be remembered that E- or K-rated expulsion fuses applied at the primary terminals of a transformer do not provide protection for currents below two times the continuous current rating of the fuse. That is, for currents that exceed the time limits shown by the fuse overload curve on **Page V14-T2-5**, the fuse may have deteriorated before the fusible element melts. In order to provide dependable overload protection for the transformer, protection must be applied on the secondary side of the transformer.

Equal concern should be given to the upper limit of continuous current rating that will provide protection for the transformer. The extent to which the fuses are to protect the transformer against secondary faults is one of several factors that determines the upper limit.

When a main secondary breaker is not used, the primary fuses may be the only devices that provide thru-fault protection for the transformer. In these circumstances the fuse should operate before the transformer windings are damaged due to heavy currents. The capability of transformer windings to carry these thru-fault or heavy currents varies from one transformer design to another. When specific information applicable to individual transformers is not available, the transformer heat curves shown on **Page V14-T2-18** can be used to evaluate the thru-fault protection offered the transformer by the fuses. The curve labeled $N=1$ is drawn through the points defined in IEEE Std. C57.92™, such that the curve has the same shape as shown in Figure 1 of IEEE publication 273 titled, "Guide to Protective Relay Application to Power Transformers". This curve applies to single-phase transformers and to three-phase faults on three-phase

transformer banks. Curves for values of N other than 1 apply to unsymmetrical faults on three-phase transformers and three-phase transformer banks that have at least one delta connected winding. Ideally, the total clearing time-current of the primary fuse would lie below the heat curve for all values of current up to 25 times the transformer rated current. However this is not usually possible as the fuse has minimum limitations placed on the rating due to long time overload impressed on the transformer and the fact that E-rated expulsion fuses do not provide protection for currents below two times their continuous current rating. In spite of these lower limitations, primary side fuses should protect the transformer for bolted secondary faults and higher impedance secondary faults to whatever extent is possible.

Wye connected transformers, regardless of whether or not the neutral is grounded, tied to the system neutral or floating have line currents that are equal to the winding currents for faults external to the transformer. Thus a fuse connected to the terminal of a wye connected winding will see the same current that is in the winding for all faults external to the transformer. Also, there is a simple relation between the primary and secondary amperes, whether or not load of fault currents are being considered.

This is not the case when the transformer has a delta connected winding, either on the primary or the secondary side of the transformer. With delta connected primary windings the current in the lines (fuses) supplying the delta winding and currents in the primary delta windings generally are not equal, and of greater importance, the ratio of line (fuse) current to the winding current varies with the type of fault on the external system. With delta connected secondary windings, the current in the transformer secondary windings is generally not equal to the secondary line current, and the ratio of primary line current to the secondary line current varies with the type of fault on the secondary system.

The relationship between rated line (fuse) current and rated winding current (referred to as the base current of the winding in IEEE/ANSI Std. C57.12.00™) is 1 for wye connected primaries and is $1/\sqrt{3}$ for delta connected primaries. IEEE/ANSI Std. C57.12.00™ also indicates that the transformer winding shall be capable of withstanding 25 times rated winding current for two seconds and smaller multiples of rated winding current for longer periods of time. However, transformer overloads and faults are generally expressed in terms of line and not winding current. This could present a problem for fault conditions where the type of fault changes the relationship between the line and the winding current. The table below gives a multiplier that will translate the line current in multiples of the winding current for different type faults for various transformer windings. These tables lead us back to the transformer heat curves shown where it can be verified that the curve N=1 passes through the point 25 times full load line current at two seconds. The curves for other than N=1 are for unsymmetrical faults as can be seen from the table below.

Coordination diagrams employ the transformer heat curves and fuse time current curves to determine which fuse rating may be safely applied. These diagrams are the tools used to apply the information previously cited. The most straightforward diagram involves fuses applied at the terminals of transformers with wye primary windings. The table below shows that the fuse current is the same as the winding current for all faults external to the transformer. This means the coordination diagram consists simply of the direct reading of the fuse time-current curves and the transformer heat curve N=1 for coordination diagrams where the abscissa is labeled in amperes in the primary system. To coordinate with the abscissa labeled in secondary amperes, the same two curves are shifted to allow for the ratio between the primary and secondary amperes.

When fuses are employed at the terminals of a delta-wye transformer, the coordination diagram becomes a bit more involved. In this instance, the table below shows that the fuse current varies in relation to the winding current depending on the nature of the fault. Thus, when the coordination is with respect to primary amperes, the diagram consists of one direct reading fuse time-current curve and one or more transformer heat curves. The number of heat curves included would be determined by the types of secondary faults considered. The table below gives the N curve to be used for the different faults to be considered. When the coordination is with respect to secondary amperes the diagram consists of one transformer heating curve (N=1) and up to three fuse time-current curves. The three time-current curves are again dependent on the possible faults to be considered. The table below shows that to obtain proper coordination after the curve is translated to secondary amperes, it must be shifted $1/\sqrt{3}$ when phase-to-ground faults are considered and $2/\sqrt{3}$ when phase-to-phase faults are considered.

Regardless of whether a primary or secondary current abscissa is employed, a coordination diagram for a delta-wye transformer shows that the primary side fuses do not protect the transformer for high impedance secondary faults and overloads. This type of protection can be obtained through the application of secondary side breakers. If a secondary breaker were used, it would be added to the coordination diagram by plotting the breaker phase and ground trip characteristics. Selective coordination would exist if the breaker phase trip characteristic curve lies below the fuse characteristic for a phase-to-phase fault and the heating curve, and breaker ground trip characteristic for a single line-to-ground fault and the heat curve.

Multiples of Primary Line Current for Fixed Secondary Winding Current

Transformer Connection All Neutrals Grounded		N (N Times Secondary Winding Current Gives Multiples of Primary Line Current)		
Primary	Secondary	Three-Phase Fault	Phase-to-Ground Fault	Phase-to-Phase Fault
Y	Y	1	1	1
Y	D	1	—	1
D	Y	1	$1/\sqrt{3}$	$2/\sqrt{3}$
D	D	1	—	$\sqrt{3}/2$

The preceding pertains to diagrams using secondary amperes. If the breaker characteristic is to be translated to primary amperes, its characteristics must lie beneath the fuse characteristic and the heating curve for $N=1$. For unsymmetrical faults the breaker characteristic will shift by the same multiple as the heating curve. If further secondary protection is translated to the primary, the characteristic must lie beneath the secondary breaker characteristic for the different types of faults considered.

Fuses used at the terminals of a delta-delta transformer require:

1. fuse time-current curves and
2. heat curves

if both three-phase and phase-to-phase faults are to be considered. This agrees with the information presented in the table on **Page V14-T2-17**. When the abscissa is in primary amperes the curves are read directly. An abscissa in secondary amperes uses the same curves but shifts them from primary to secondary amperes.

When using the current generation of protection and coordination computer programs, all the factors such as the ratios of line to winding ratios and transformation ratios should be accounted for by the software if the transformer details are correctly entered into the program, and it should only be necessary to correctly interpret the program plots to evaluate the levels of secondary to primary protection, and the level of transformer overload protection afforded by a selected fuse rating.

For all the coordination diagrams discussed above, the vertical distance between the total clearing curve and the safe heat curve indicates the margin of protection offered for different types of faults. It should be remembered, however, that the transformer heat curves illustrated in this application data are drawn from the reference previously cited and they may not apply to all transformer designs.

In practice, it is not always possible to select a fuse large enough to allow for all the over-loading required and still provide complete protection for the transformer. In these cases, the user should decide where his priorities lie and trade off overloading ability for transformer protection.

Typical Transformer Heat Curves

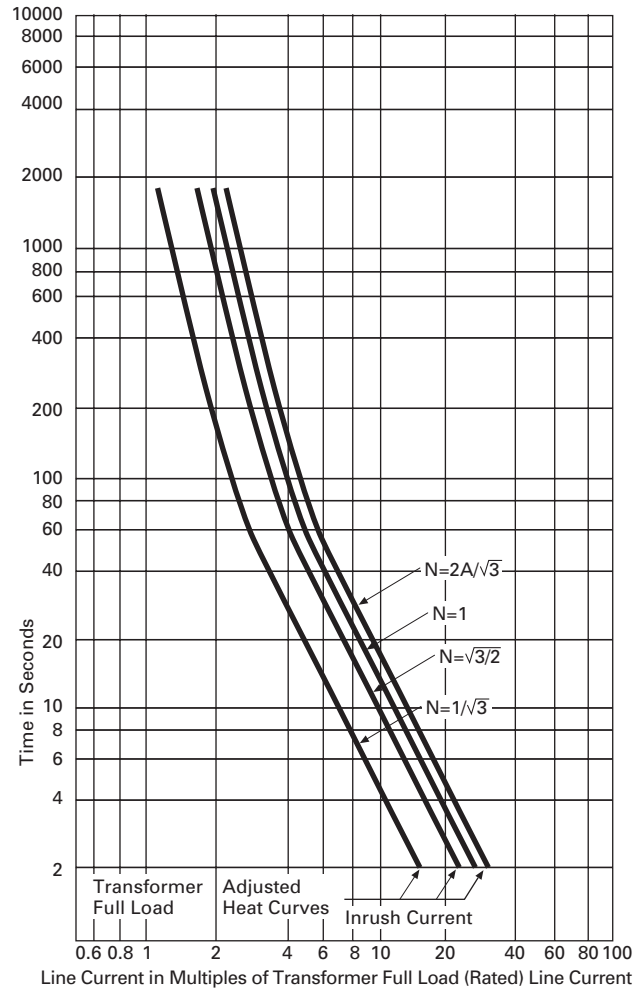

Capacitor Application

Another common use of power fuses is for the protection of capacitor banks. This application is unique in that the protected equipment, capacitors, are designed with a zero minus tolerance and some value positive tolerance. For this

reason a ratio of 1.65:1 fuse rating to full load current is suggested for all single bank protection. If two or more banks are paralleled with automatic switching, refer to Eaton Technical Support for fusing information.

Repetitive Faults

Temperature Cycle of a Fuse During Reclosing Operation

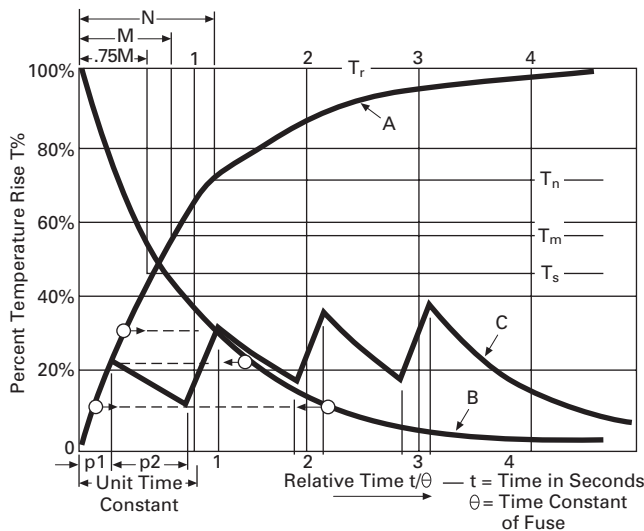

Curve A—Basic fuse heating curve: $T_f (1 - e^{-t/\theta})$
 Curve B—Basic fuse cooling curve: $T_f \times e^{-t/\theta}$
 Curve C—Temperature rise curve of fuse subjected to reclosing cycle
 M—Melting time of fuse at a given fault current
 N—Total clearing time of fuse at same fault current
 T_m, T_n—Levels of melting temperature of fastest and of slowest fuse (See note below)
 T_s—Safe temperature level, considering service variables
 T_r—Hypothetical steady-state temperature level (100%) attained if the fuse element did not open when melting temperature was reached but continued to be a resistance of constant value

Note: The absolute temperature at which the elements of the fastest and of the slowest fuse melt is the same since both fuses are made of the same material, However, T_n and T_m are different if measured by the final temperature level if reached at a given current.

It is often desirable to determine the performance of fuses under repetitive faults such as produced by the operation of reclosing circuit breakers. This performance is determined by graphically simulating the heating and cooling characteristics of the fuse, which are found and expressed by the melting time-current curves. The theory behind the above implications is available upon request, but in this section only the practical use of those implications will be discussed.

Conventional E-rated fuses can with good approximation be regarded as bodies whose heating and cooling properties are described by the basic exponential curves A and B as shown above. Except for being inverted, the cooling curve is the same as the heating curve as both have the same time constant. Each fuse has a specific time constant that can be calculated with sufficient accuracy by the formula $\theta = 0.1S^2$ where S is the fuse speed ratio, that is, the melting current at 0.1 seconds divided by the melting current at 300 or 600 seconds. The 300 seconds applies to fuses rated 100A or less and the 600 seconds for fuses rated above 100A.

The time constant of a specific fuse, having been obtained in terms of seconds, gives to the general heating and cooling curves shown below a specific time scale. In enables us to plot the course of the fuse

temperature (in percent values) if we know the sequence and duration of the open and closed periods of the recloser. This is illustrated by curve C that is formed by piecing together the proper sections of curves A and B.

Reclosing Circuit Breaker Fuse Coordination

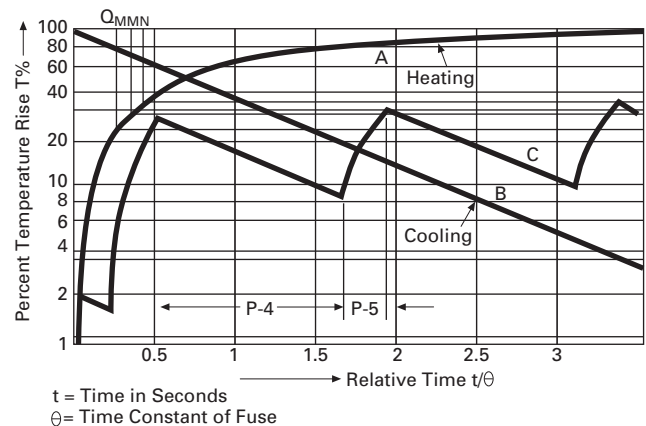

t = Time in Seconds
 θ = Time Constant of Fuse
Notes: Recloser data: 400PR (cycling code A1-3CH3).
 Fuse type and rating: CLT (drawout) 8.3 kV 150°C.
 Fuse speed ratio, S-2150/420 = 5.11.
 Thermal time constant, $\theta = 0.10 S^2$, 2.61 seconds.
 Fault current 1350A.

Next we must determine the temperature at which the fuse element will melt. Here we refer to the standard time-current curves and find the melting time M for specific value of fault current. The melting temperature T_m lies where the ordinate to the time M intersects curve A. It is not necessary to know the absolute value of this temperature, as it is sufficient to know its relation to the peaks. A similar temperature T_n can be found using the total clearing time for the specific fault current. What we have then are two temperatures where we can state that any time the curve C intersects the line T_m, the fuse could operate and any time it intersects line T_n the fuse will definitely operate. The gap between T_m and T_n indicates the tolerance range as set forth in ANSI and NEMA® standards where E-rated fuses are defined.

If the fuse is not to operate, curve C must remain below the level T_m by a safe margin. It is common practice to provide such a safety margin by coordinating the breaker with a fuse curve whose time ordinates are 75 percent of those of the melting curve. Line T_s represents this temperature in illustration above.

Although the construction of the temperature diagram as outlined above basically offers no difficulties, the manipulation is made easier and more accurate by putting the graph on semi-log coordinates as shown. On these coordinates, the cooling curve B becomes a straight line.

BA Fuseholder



2

Contents

Description

	<i>Page</i>
BA Type Fuses	
Catalog Number Selection	V14-T2-21
Interrupting Ratings	V14-T2-21
Product Selection	V14-T2-22

BA Type Fuses

Product Description

The refillable BA type (boric acid) high voltage expulsion fuse is an E-rated fuse that can be vented (outdoor) or enclosed (indoor). These fuses are designed for power applications and were introduced by the Westinghouse Electric Company in the middle 1930s. The refill units have been in continuous production since that time and are still available for use in existing installations.

Mountings are no longer available for use with BA refill units, but a limited range of replacement fuse holders is still available.

New and replacement applications should use RBA fuses that superseded BA fuses a number of years ago.

Introduction

BA power fuses provide protection for circuits and equipment that operate on voltages from 7.2 to 38 kV. When the calibrated current responsive element melts, the fuse reacts rapidly to de-ionize the arc and interrupt the circuit. On outdoor vented installations, a mechanical dropout action gives a 180° air break. On indoor applications, the arc exhaust is absorbed by the attached exhaust control device (filter or condenser). The fuse refill unit is of the replaceable type rather than the renewable type, resulting in light weight for ease in handling.

Construction

DE-ION® arc interruption permits application of the BA type power fuse over a range of system voltages. This line of dropout fuses carries the boric acid principle of circuit protection to higher voltage ratings, and at the same time provides short-circuit protection for systems of moderate capacity at a lower cost.

Main operating parts are the fusible element, arcing rod, helical spring, and dry boric acid cylinder. To prevent warping under outdoor conditions, a heavy glass-epoxy or ceramic tube encloses the entire assembly. This glass-epoxy tube also assures adequate strength to contain the force of the arc interruption.

Within the fuse, the current path is maintained by tight electrical connections. From the top ferrule, the path is through the extended spring and shunt assembly; then to the arcing rod, on through the fusible element that is bridged by the mechanical strain element, and into the bottom ferrule. When the fuse element melts, the arcing rod is pulled upward drawing the arc into the boric acid cylinder. As it strikes, intense heat from the arc decomposes the compressed boric acid powder.

Decomposition of the dry boric acid forms water vapor and boric acid anhydride. The electrical interruption is caused by the steam cooling and de-ionizing the arc as it is drawn through the cylinder by the action of the spring and rod.

Operation

BA type fuses are of the refillable type. When a fuse operates due to a fault blown, the fuse holder is removed with from the mounting. After replacement of the refill unit, the fuse holder can be reinserted into the fuse mounting.

Application

BA fuses are applied in utility and industrial high voltage power systems for protecting:

- Power transformers
- Feeder circuit sectionalizing
- Distribution transformers
- Potential transformers

Ratings

- 8.3 to 38 kV
- 0.5E to 400E Amperes

Catalog Number Selection

BA Fuse Units

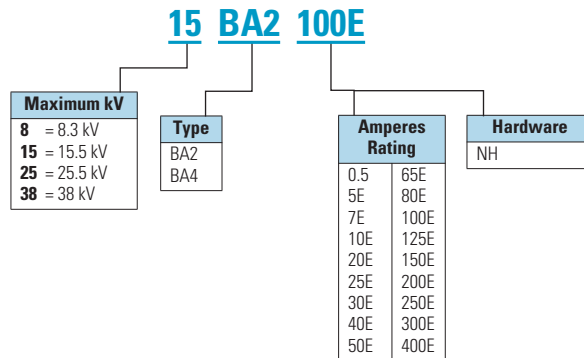

Interrupting Ratings

BA Fuse Interrupting Ratings

Refill Maximum Rated Voltage Rating kV	Maximum System Voltage kV	Vented or with Filter rms Symmetrical kA	With Condenser rms Symmetrical kA
8.3	2.75	17.5	10.0
—	5.5	17.5	10.0
—	8.3	16.0	10.0
15.5	15.5	12.5	8.0
25.8	25.8	10.0	6.3
38	38	6.3	5.0

2.4

Expulsion Fuses

BA Type Fuses

Product Selection

2

BA2 Type Expulsion Fuse Refill Units

Voltage (kV)

Performance Curves

Nominal	Maximum	Ampere Rating	Catalog Number	Approximate Shipping Weight Lbs (kg)	Minimum Melting	Total Clearing
7.2	8.3	0.5	8BA2-5	1.0 (0.45)	TC28115801	TC28021601
7.2	8.3	5E	8BA2-5E	1.0 (0.45)	TC28115801	TC28021601
7.2	8.3	7E	8BA2-7E	1.0 (0.45)	TC28115801	TC28021601
7.2	8.3	10E	8BA2-10E	1.0 (0.45)	TC28115801	TC28021601
7.2	8.3	15E	8BA2-15E	1.0 (0.45)	TC28115801	TC28021601
7.2	8.3	20E	8BA2-20E	1.0 (0.45)	TC28115801	TC28021601
7.2	8.3	25E	8BA2-25E	1.0 (0.45)	TC28115801	TC28021601
7.2	8.3	30E	8BA2-30E	1.0 (0.45)	TC28115801	TC28021601
7.2	8.3	40E	8BA2-40E	1.0 (0.45)	TC28115801	TC28021601
7.2	8.3	50E	8BA2-50E	1.0 (0.45)	TC28115801	TC28021601
7.2	8.3	65E	8BA2-65E	1.0 (0.45)	TC28115801	TC28021601
7.2	8.3	80E	8BA2-80E	1.0 (0.45)	TC28115801	TC28021601
7.2	8.3	100E	8BA2-100E	1.0 (0.45)	TC28115801	TC28021601
7.2	8.3	125E	8BA2-125E	1.0 (0.45)	TC28115801	TC28021601
7.2	8.3	150E	8BA2-150E	1.0 (0.45)	TC28115801	TC28021601
7.2	8.3	200E	8BA2-200E	1.0 (0.45)	TC28115801	TC28021601
14.4	15.5	0.5	15BA2-5	1.2 (0.55)	TC28115801	TC28021601
14.4	15.5	5E	15BA2-5E	1.2 (0.55)	TC28115801	TC28021601
14.4	15.5	7E	15BA2-7E	1.2 (0.55)	TC28115801	TC28021601
14.4	15.5	10E	15BA2-10E	1.2 (0.55)	TC28115801	TC28021601
14.4	15.5	15E	15BA2-15E	1.2 (0.55)	TC28115801	TC28021601
14.4	15.5	20E	15BA2-20E	1.2 (0.55)	TC28115801	TC28021601
14.4	15.5	25E	15BA2-25E	1.2 (0.55)	TC28115801	TC28021601
14.4	15.5	30E	15BA2-30E	1.2 (0.55)	TC28115801	TC28021601
14.4	15.5	40E	15BA2-40E	1.2 (0.55)	TC28115801	TC28021601
14.4	15.5	50E	15BA2-50E	1.2 (0.55)	TC28115801	TC28021601
14.4	15.5	65E	15BA2-65E	1.2 (0.55)	TC28115801	TC28021601
14.4	15.5	80E	15BA2-80E	1.2 (0.55)	TC28115801	TC28021601
14.4	15.5	100E	15BA2-100E	1.2 (0.55)	TC28115801	TC28021601
14.4	15.5	125E	15BA2-125E	1.2 (0.55)	TC28115801	TC28021601
14.4	15.5	150E	15BA2-150E	1.2 (0.55)	TC28115801	TC28021601
14.4	15.5	200E	15BA2-200E	1.2 (0.55)	TC28115801	TC28021601

BA2 Type Expulsion Fuse Refill Units, continued

Voltage (kV)				Performance Curves		
Nominal	Maximum	Ampere Rating	Catalog Number	Approximate Shipping Weight Lbs (kg)	Minimum Melting	Total Clearing
23	25.5	0.5	25BA2-.5	1.5 (0.7)	TC28115801	TC28021601
23	25.5	5E	25BA2-5E	1.5 (0.7)	TC28115801	TC28021601
23	25.5	7E	25BA2-7E	1.5 (0.7)	TC28115801	TC28021601
23	25.5	10E	25BA2-10E	1.5 (0.7)	TC28115801	TC28021601
23	25.5	15E	25BA2-15E	1.5 (0.7)	TC28115801	TC28021601
23	25.5	20E	25BA2-20E	1.5 (0.7)	TC28115801	TC28021601
23	25.5	25E	25BA2-25E	1.5 (0.7)	TC28115801	TC28021601
23	25.5	30E	25BA2-30E	1.5 (0.7)	TC28115801	TC28021601
23	25.5	40E	25BA2-40E	1.5 (0.7)	TC28115801	TC28021601
23	25.5	50E	25BA2-50E	1.5 (0.7)	TC28115801	TC28021601
23	25.5	65E	25BA2-65E	1.5 (0.7)	TC28115801	TC28021601
23	25.5	80E	25BA2-80E	1.5 (0.7)	TC28115801	TC28021601
23	25.5	100E	25BA2-100E	1.5 (0.7)	TC28115801	TC28021601
23	25.5	125E	25BA2-125E	1.5 (0.7)	TC28115801	TC28021601
23	25.5	150E	25BA2-150E	1.5 (0.7)	TC28115801	TC28021601
23	25.5	200E	25BA2-200E	1.5 (0.7)	TC28115801	TC28021601
34.5	38	0.5	38BA2-.5	1.8 (0.82)	TC28115801	TC28021601
34.5	38	5E	38BA2-5E	1.8 (0.82)	TC28115801	TC28021601
34.5	38	7E	38BA2-7E	1.8 (0.82)	TC28115801	TC28021601
34.5	38	10E	38BA2-10E	1.8 (0.82)	TC28115801	TC28021601
34.5	38	15E	38BA2-15E	1.8 (0.82)	TC28115801	TC28021601
34.5	38	20E	38BA2-20E	1.8 (0.82)	TC28115801	TC28021601
34.5	38	25E	38BA2-25E	1.8 (0.82)	TC28115801	TC28021601
34.5	38	30E	38BA2-30E	1.8 (0.82)	TC28115801	TC28021601
34.5	38	40E	38BA2-40E	1.8 (0.82)	TC28115801	TC28021601
34.5	38	50E	38BA2-50E	1.8 (0.82)	TC28115801	TC28021601
34.5	38	65E	38BA2-65E	1.8 (0.82)	TC28115801	TC28021601
34.5	38	80E	38BA2-80E	1.8 (0.82)	TC28115801	TC28021601
34.5	38	100E	38BA2-100E	1.8 (0.82)	TC28115801	TC28021601
34.5	38	125E	38BA2-125E	1.8 (0.82)	TC28115801	TC28021601
34.5	38	150E	38BA2-150E	1.8 (0.82)	TC28115801	TC28021601
34.5	38	200E	38BA2-200E	1.8 (0.82)	TC28115801	TC28021601

2.4

Expulsion Fuses

BA Type Fuses

BA4 Type Expulsion Fuse Refill Units

Voltage (kV)

Performance Curves

2

Nominal	Maximum	Ampere Rating	Catalog Number	Approximate Shipping Weight Lbs (kg)	Minimum Melting	Total Clearing
7.2	8.3	0.5	8BA4-5	2 (0.9)	TC28021201	TC28021401
7.2	8.3	5E	8BA4-5E	2 (0.9)	TC28021201	TC28021401
7.2	8.3	7E	8BA4-7E	2 (0.9)	TC28021201	TC28021401
7.2	8.3	10E	8BA4-10E	2 (0.9)	TC28021201	TC28021401
7.2	8.3	15E	8BA4-15E	2 (0.9)	TC28021201	TC28021401
7.2	8.3	20E	8BA4-20E	2 (0.9)	TC28021201	TC28021401
7.2	8.3	25E	8BA4-25E	2 (0.9)	TC28021201	TC28021401
7.2	8.3	30E	8BA4-30E	2 (0.9)	TC28021201	TC28021401
7.2	8.3	40E	8BA4-40E	2 (0.9)	TC28021201	TC28021401
7.2	8.3	50E	8BA4-50E	2 (0.9)	TC28021201	TC28021401
7.2	8.3	65E	8BA4-65E	2 (0.9)	TC28021201	TC28021401
7.2	8.3	80E	8BA4-80E	2 (0.9)	TC28021201	TC28021401
7.2	8.3	100E	8BA4-100E	2 (0.9)	TC28021201	TC28021401
7.2	8.3	125E	8BA4-125E	2 (0.9)	TC28021201	TC28021401
7.2	8.3	150E	8BA4-150E	2 (0.9)	TC28021201	TC28021401
7.2	8.3	200E	8BA4-200E	2 (0.9)	TC28021201	TC28021401
7.2	8.3	250E	8BA4-250E	2 (0.9)	TC28021201	TC28021401
7.2	8.3	300E	8BA4-300E	2 (0.9)	TC28021201	TC28021401
7.2	8.3	400E	8BA4-400E	2 (0.9)	TC28021201	TC28021401
14.4	15.5	0.5	15BA4-5	2.5 (1.15)	TC28021201	TC28021401
14.4	15.5	5E	15BA4-5E	2.5 (1.15)	TC28021201	TC28021401
14.4	15.5	7E	15BA4-7E	2.5 (1.15)	TC28021201	TC28021401
14.4	15.5	10E	15BA4-10E	2.5 (1.15)	TC28021201	TC28021401
14.4	15.5	15E	15BA4-15E	2.5 (1.15)	TC28021201	TC28021401
14.4	15.5	20E	15BA4-20E	2.5 (1.15)	TC28021201	TC28021401
14.4	15.5	25E	15BA4-25E	2.5 (1.15)	TC28021201	TC28021401
14.4	15.5	30E	15BA4-30E	2.5 (1.15)	TC28021201	TC28021401
14.4	15.5	40E	15BA4-40E	2.5 (1.15)	TC28021201	TC28021401
14.4	15.5	50E	15BA4-50E	2.5 (1.15)	TC28021201	TC28021401
14.4	15.5	65E	15BA4-65E	2.5 (1.15)	TC28021201	TC28021401
14.4	15.5	80E	15BA4-80E	2.5 (1.15)	TC28021201	TC28021401
14.4	15.5	100E	15BA4-100E	2.5 (1.15)	TC28021201	TC28021401
14.4	15.5	125E	15BA4-125E	2.5 (1.15)	TC28021201	TC28021401
14.4	15.5	150E	15BA4-150E	2.5 (1.15)	TC28021201	TC28021401
14.4	15.5	200E	15BA4-200E	2.5 (1.15)	TC28021201	TC28021401
14.4	15.5	250E	15BA4-250E	2.5 (1.15)	TC28021201	TC28021401
14.4	15.5	300E	15BA4-300E	2.5 (1.15)	TC28021201	TC28021401
14.4	15.5	400E	15BA4-400E	2.5 (1.15)	TC28021201	TC28021401

BA4 Type Expulsion Fuse Refill Units, continued

Voltage (kV)

Performance Curves

Nominal	Maximum	Ampere Rating	Catalog Number	Approximate Shipping Weight Lbs (kg)	Performance Curves	
					Minimum Melting	Total Clearing
23	25.5	0.5	25BA4-5	3.5 (1.6)	TC28021201	TC28021401
23	25.5	5E	25BA4-5E	3.5 (1.6)	TC28021201	TC28021401
23	25.5	7E	25BA4-7E	3.5 (1.6)	TC28021201	TC28021401
23	25.5	10E	25BA4-10E	3.5 (1.6)	TC28021201	TC28021401
23	25.5	15E	25BA4-15E	3.5 (1.6)	TC28021201	TC28021401
23	25.5	20E	25BA4-20E	3.5 (1.6)	TC28021201	TC28021401
23	25.5	25E	25BA4-25E	3.5 (1.6)	TC28021201	TC28021401
23	25.5	30E	25BA4-30E	3.5 (1.6)	TC28021201	TC28021401
23	25.5	40E	25BA4-40E	3.5 (1.6)	TC28021201	TC28021401
23	25.5	50E	25BA4-50E	3.5 (1.6)	TC28021201	TC28021401
23	25.5	65E	25BA4-65E	3.5 (1.6)	TC28021201	TC28021401
23	25.5	80E	25BA4-80E	3.5 (1.6)	TC28021201	TC28021401
23	25.5	100E	25BA4-100E	3.5 (1.6)	TC28021201	TC28021401
23	25.5	125E	25BA4-125E	3.5 (1.6)	TC28021201	TC28021401
23	25.5	150E	25BA4-150E	3.5 (1.6)	TC28021201	TC28021401
23	25.5	200E	25BA4-200E	3.5 (1.6)	TC28021201	TC28021401
23	25.5	250E	25BA4-250E	3.5 (1.6)	TC28021201	TC28021401
23	25.5	300E	25BA4-300E	3.5 (1.6)	TC28021201	TC28021401
34.5	38	0.5	38BA4-5	4 (1.8)	TC28021201	TC28021401
34.5	38	5E	38BA4-5E	4 (1.8)	TC28021201	TC28021401
34.5	38	7E	38BA4-7E	4 (1.8)	TC28021201	TC28021401
34.5	38	10E	38BA4-10E	4 (1.8)	TC28021201	TC28021401
34.5	38	15E	38BA4-15E	4 (1.8)	TC28021201	TC28021401
34.5	38	20E	38BA4-20E	4 (1.8)	TC28021201	TC28021401
34.5	38	25E	38BA4-25E	4 (1.8)	TC28021201	TC28021401
34.5	38	30E	38BA4-30E	4 (1.8)	TC28021201	TC28021401
34.5	38	40E	38BA4-40E	4 (1.8)	TC28021201	TC28021401
34.5	38	50E	38BA4-50E	4 (1.8)	TC28021201	TC28021401
34.5	38	65E	38BA4-65E	4 (1.8)	TC28021201	TC28021401
34.5	38	80E	38BA4-80E	4 (1.8)	TC28021201	TC28021401
34.5	38	100E	38BA4-100E	4 (1.8)	TC28021201	TC28021401
34.5	38	125E	38BA4-125E	4 (1.8)	TC28021201	TC28021401
34.5	38	150E	38BA4-150E	4 (1.8)	TC28021201	TC28021401
34.5	38	200E	38BA4-200E	4 (1.8)	TC28021201	TC28021401
34.5	38	250E	38BA4-250E	4 (1.8)	TC28021201	TC28021401
34.5	38	300E	38BA4-300E	4 (1.8)	TC28021201	TC28021401

2.4

Expulsion Fuses

BA Type Fuses

2

BA2 Type Expulsion Fuse Fuse Holders and Exhaust Control Devices ^{①②}

Voltage (kV)			Non-Disconnect Fuse Holder Catalog Number	Exhaust Control Device	
Nominal	Maximum	Ampere Rating		Filter Catalog Number	Condenser Catalog Number
7.2	8.3	0.5–200E	8BA2-NH	RBA2-FLTR	RBA2-COND
14.4	15.5	0.5–200E	15BA2-NH	RBA2-FLTR	RBA2-COND
23	25.5	0.5–200E	—	RBA2-FLTR	RBA2-COND
34.5	38	0.5–200E	—	RBA2-FLTR	RBA2-COND

BA4 Type Expulsion Fuse Fuse Holders and Exhaust Control Devices ^{①②}

Voltage (kV)			Non-Disconnect Fuse Holder Catalog Number	Exhaust Control Device	
Nominal	Maximum	Ampere Rating		Filter Catalog Number	Condenser Catalog Number
7.2	8.3	0.5–400E	8BA4-NH	RBA4-FLTR	RBA4-COND
14.4	15.5	0.5–400E	15BA4-NH	RBA4-FLTR	RBA4-COND
23	25.5	0.5–300E	—	RBA4-FLTR	RBA4-COND
34.5	38	0.5–300E	—	RBA4-FLTR	RBA4-COND

Notes

- ① Available as replacements in exiting installations. For new installations, use RBA fuse assemblies.
- ② Mounting no longer available. If mounting is required, convert installation to RBA fuse assemblies.

DBA Fuse



DBA Type Fuses

Product Description

The DBA type (dropout, boric acid) high voltage expulsion fuse is an E-rated, vented device designed for power applications.

Introduction

The DBA power fuse provides double protection for circuits and equipment that operate on voltages from 7.2 to 145 kV. The fuse has instant acting DE-ION circuit interruption and almost simultaneously, a mechanical dropout action gives a 180° air break. The fuse unit is of the replaceable type rather than the renewable type, resulting in light weight for ease in handling.

Construction

DE-ION arc interruption permits application of the DBA type power fuse over a wide range of system voltages. This line of dropout fuses carries the boric acid principle of circuit protection to higher voltage ratings, and at the same time provides at lower cost short-circuit protection for systems of moderate capacity.

Principle parts of the DBA fuse unit are shown in the cross section illustration on this page. Main operating parts are the fusible element, arcing rod, helical spring, and dry boric acid cylinder. To prevent warping under outdoor conditions, a heavy Micarta tube encloses the entire assembly. This Micarta tube also assures adequate strength to contain the force of the arc interruption.

Contents

Description

	<i>Page</i>
DBA Type Fuses	V14-T2-27
Catalog Number Selection	V14-T2-32
Interrupting Ratings	V14-T2-32
Product Selection	V14-T2-33

Within the fuse unit, the current path is maintained by tight electrical connections. From the top ferrule, the path is to the copper tube spring shunt; then to the arcing rod collar and the arcing rod, on through the fusible element that is bridged by the strain element, and into the bottom ferrule. The copper spring shunt and the arcing rod collar are firmly held together by the contact finger spring. When the fuse element is blown, the arcing rod is pulled upward drawing the arc into the boric acid cylinder. The spring shunt contact fingers close in on the rod to maintain the electrical path. Intense heat from the arc, as it strikes, decomposes the compressed boric acid powder.

Decomposition of the dry boric acid forms water vapor and boric acid anhydride. The electrical interruption is caused by the steam de-ionizing the arc as it is drawn through the cylinder by action of the spring and rod.

The arcing rod is prevented from falling back into the fuse until after interruption by a friction stop just inside the top ferrule.

DBA Fuse Construction

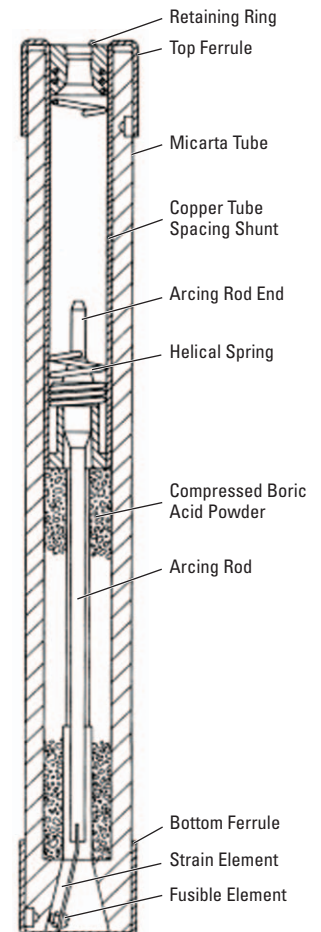

Operation

The DBA type fuse unit is of the replaceable type rather than the renewable type. When the fuse has blown and drop-out completed, the entire unit is removed with a switch stick. After replacement of the blown unit, it is closed back into place with the switch stick.

In replacing the blown fuse, the end fittings are removed and clamped on a new fuse. End fittings consist of an operating eye at the top and hinge lifting eye at the bottom. The two fittings have different shapes and are keyed with different projections. Fittings are simple to remove or replace, and cannot be reversed since the keys insure quick, correct alignment.

DE-ION circuit interruption by action of the boric acid fuse unit is followed simultaneously by a mechanical drop-out action. When closing the fuse unit with the switch stick, the ejector casting located under the sleet hood, compresses the ejector spring. Under fault conditions the fuse element melts, the helical spring pulls the arcing rod and arc through the cylinder. The upper end of the arcing rod drives through a small hole in the top of the ferrule of the fuse unit and strikes the trigger-releasing ejector. The trigger operates and causes the ejector spring

to force the ejector casting against the fuse assembly forcing it outward to swing through a 180° arc into a drop-out position. Drop-out action provides immediate visual indication that the particular circuit in which the fuse is connected has been interrupted. The additional drop-out break insulates the fault from the feeders with an air gap of at least one foot on lower voltage system and up to six feet on higher voltage systems.

This air break eliminates any possibility of carbonized fuse parts breaking down to allow leakage or another fault. Since drop-out action takes place after current interruption within the boric acid cylinder, burning or arcing at the contact surfaces is eliminated.

Application

The DBA fuse is applicable in utility and industrial high voltage power systems for protecting:

- Power transformers
- Feeder circuit sectionalizing
- Distribution transformers
- Potential transformers

Ratings

- 8.3 to 145 kV
- 0.5E to 200E Amperes

The power fuse is an inherently fast circuit-interrupting device. This must be taken into account when determining the required short-circuit interrupting rating of a fuse.

The boric acid power fuse will interrupt currents of short-circuit magnitude in approximately 1/2 cycle measured from the instant of short-circuit. During this 1/2 cycle, the short-circuit current may be much higher than the sustained rms short-circuit current of the system at that point. The fuse must be capable of safely interrupting this transient current that might exist at the instant the fuse operates.

In an alternating current circuit containing inductance, a sudden change in the AC current is accompanied by a transient DC component that is a function of the AC current before and after the change and the point on the cycle at that the change occurs. The decrement of the transient is a function of the inductance and resistance or losses of the circuit.

If a short is suddenly established on a circuit, the DC component can have a maximum peak value equal to the crest of the 60 cycle short-circuit current of the system.

This maximum transient is obtained if the fault occurs at voltage zero. Due to the system losses, this DC component will die out to a low value in a few cycles. However, a fuse normally interrupts a short-circuit in 1/2 cycle, and this DC component of current must be taken into consideration in rating the fuse. If the decrement of DC component in this half cycle is neglected, the rms value of current for the totally asymmetrical condition would be 1.73 times the rms symmetrical value of the 60 cycle component.

Experience has shown that there is some decrement in this first half cycle and also that the current is limited somewhat by the arc drop in the fuse. For this reason, a ratio of 1.6 has been selected between the rms asymmetrical current the fuse must be designed to interrupt, and the rms short-circuit of the system on which the fuse is to be used. This instantaneous rms asymmetrical value of short-circuit current, which the fuse must be designed to interrupt, is often referred to as the rms symmetrical value including the DC component. The asymmetrical value is obtained by multiplying the symmetrical value by 1.6. The symmetrical value of short-circuit current on a three-phase system is determined by dividing the available three-phase, short-circuit kVA by the product of the system voltage and $1/\sqrt{3}$.

Instructions for DBA Type Fuse Units 8.3 kV to 145 kV**Installation of Replacement Fuses**

DBA fuse units are available in two classifications, DBA-1 and DBA-2 and are used for utility-type applications from 8.3 kV through 145 kV.

Remove fuses from all three phases and replace with new or tested units. Fuses having been involved in a fault but not blown should be tested by resistance measurements to ascertain that they are suitable for continued service. Resistance limits are available on request.

Prior to installation, it is advisable to check the functioning of the mounting as follows:

1. Remove fuse fittings from hinge casting (see the figures on **Pages V14-T2-30** and **V14-T2-31**) and mount on a suitable fuse unit as shown in the figure on this page.
2. Check gauging distance "S" between center of guide pin in latch housing and bottom of socket in hinge casting as illustrated in the figures on **Pages V14-T2-30** and **V14-T2-31**. Dimension "S" must measure the same on both sides of the mounting. If dimension "S" is found to be incorrect, adjust it by using the clearances provided in the bolt holes (see the figures on **Pages V14-T2-30** and **V14-T2-31**).

3. Put the suitable fuse unit equipped with fittings in the mounting. Check operation of latch assembly by closing and opening the fuse as shown in the figures on **Pages V14-T2-30** and **V14-T2-31**.

DBA-1 fuses up to 69 kV as well as DBA-2 fuses up to 46 kV can be lifted into the hinge casting by means of conventional all-purpose switch sticks. For lifting heavier fuses into the hinge, a switch stick about one foot shorter than the distance from ground level to the fuse hinge is recommended. This switch stick should be held approximately vertical as shown in the figures on **Pages V14-T2-30** and **V14-T2-31**.

For the closing-in or disconnecting operation, a switch stick of at least four foot greater length should be employed. Insert the switch stick pin into the eye of the fuse fitting from the right-hand side and have it form an angle of at least 35° with the fuse.

Fuse should be closed in with a sharp thrust. A similar impact-like pull is required to open the fuse. After the latch contacts have parted, the fuse may be allowed to disengage itself from the switch stick and drop out in a normal manner.

Maintenance

General maintenance instructions are published in the IEEE Std. C-37.48™-1973. Inspection of the fuse mounting should include checking the gauge distance "S" (see the figures on **Pages V14-T2-30** and **V14-T2-31**) and the operation of the latch mechanism.

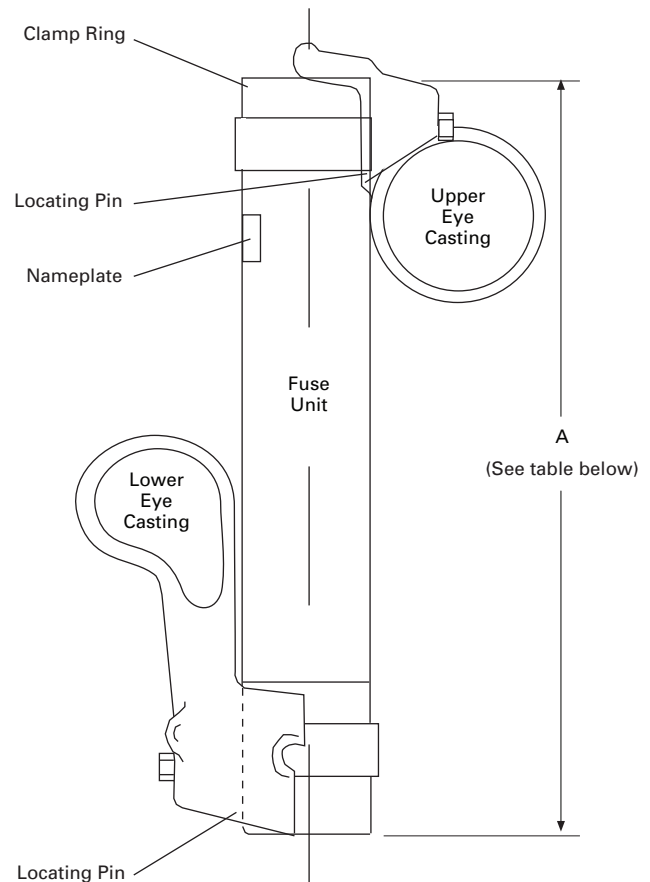
Fuse Unit With Fittings

kV	Dimensions in Inches (mm)	
	DBA-1	DBA-2
8.3	13.5 (342.9)	—
15.5	17.0 (431.8)	—
25.5	21.5 (546.1)	—
38	28.5 (723.9)	28.13 (714.5)
48.3	34.0 (863.6)	33.63 (854.2)
69	43.88 (1,114.6)	43.63 (1,108.2)
92	—	52.0 (1,320.8)
121	—	62.0 (1,574.8)
145	—	72.0 (1,828.8)

2.5

Expulsion Fuses

DBA Type Fuses

Insulator Spacing

Approximate Dimensions in Inches (mm)

2

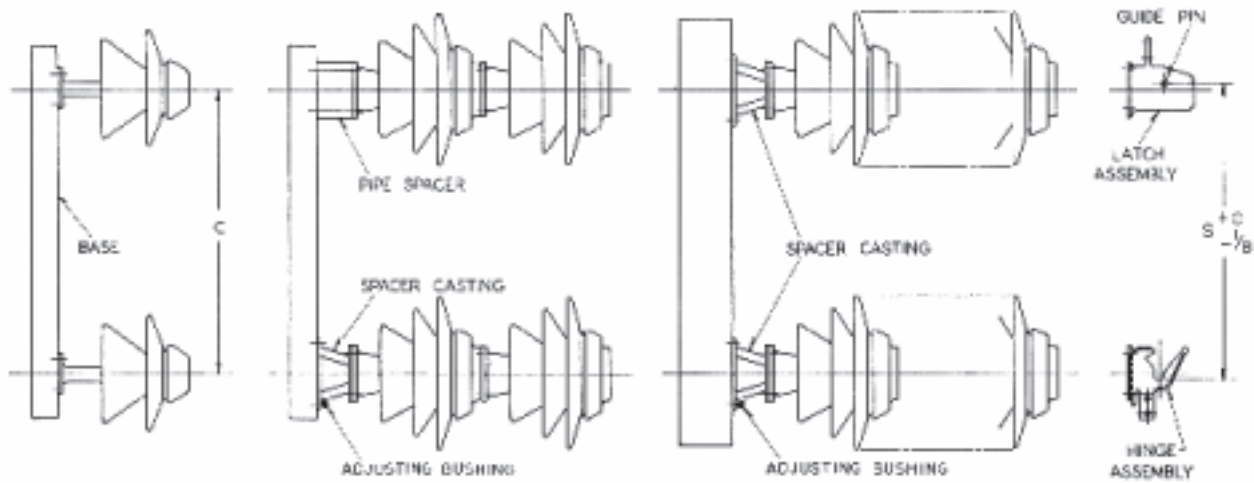

7.2 to 46 kV

69 kV

92 to 138 kV

kV	Dimension C		Dimension S	
	DBA-1	DBA-2	DBA-1	DBA-2
7.2	13.63 (346.2)	—	15.25 (387.4)	—
15	17.13 (435.1)	—	18.75 (476.3)	—
23	21.63 (549.4)	—	23.25 (590.6)	—
34.5	28.63 (727.2)	27.88 (708.2)	30.25 (768.4)	—
46	34.13 (866.9)	33.38 (847.9)	35.75 (908.1)	—
69	44.00 (1117.6)	43.38 (1101.9)	45.63 (1159.0)	—
92	—	51.75 (1314.5)	—	—
115	—	61.75 (1568.5)	—	—
138	—	71.75 (1822.5)	—	—

Hinge Assembly

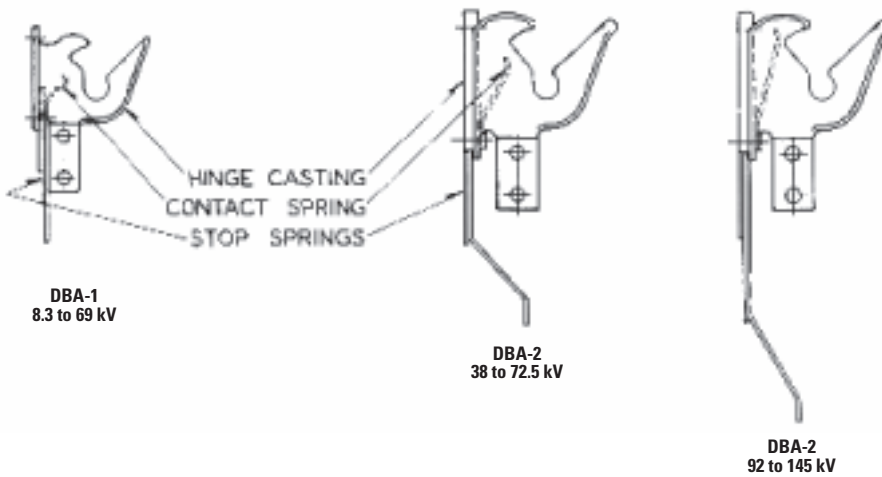

DBA-1
8.3 to 69 kV

DBA-2
38 to 72.5 kV

DBA-2
92 to 145 kV

Spacer Adjustment

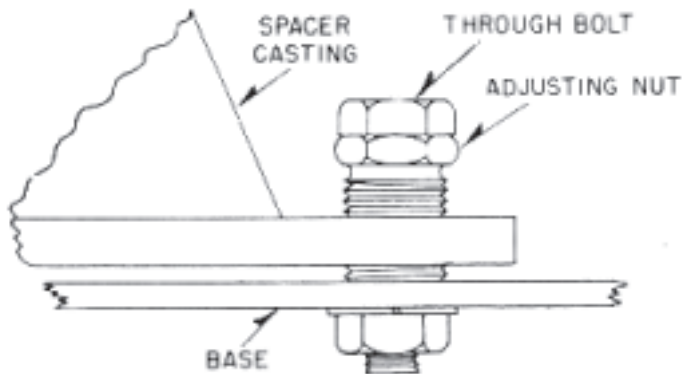

Procedure

1. Loosen all four through bolts.
2. Turn adjusting nut the desired amount.
3. Retighten all four through bolts.

Switch Stick Operation

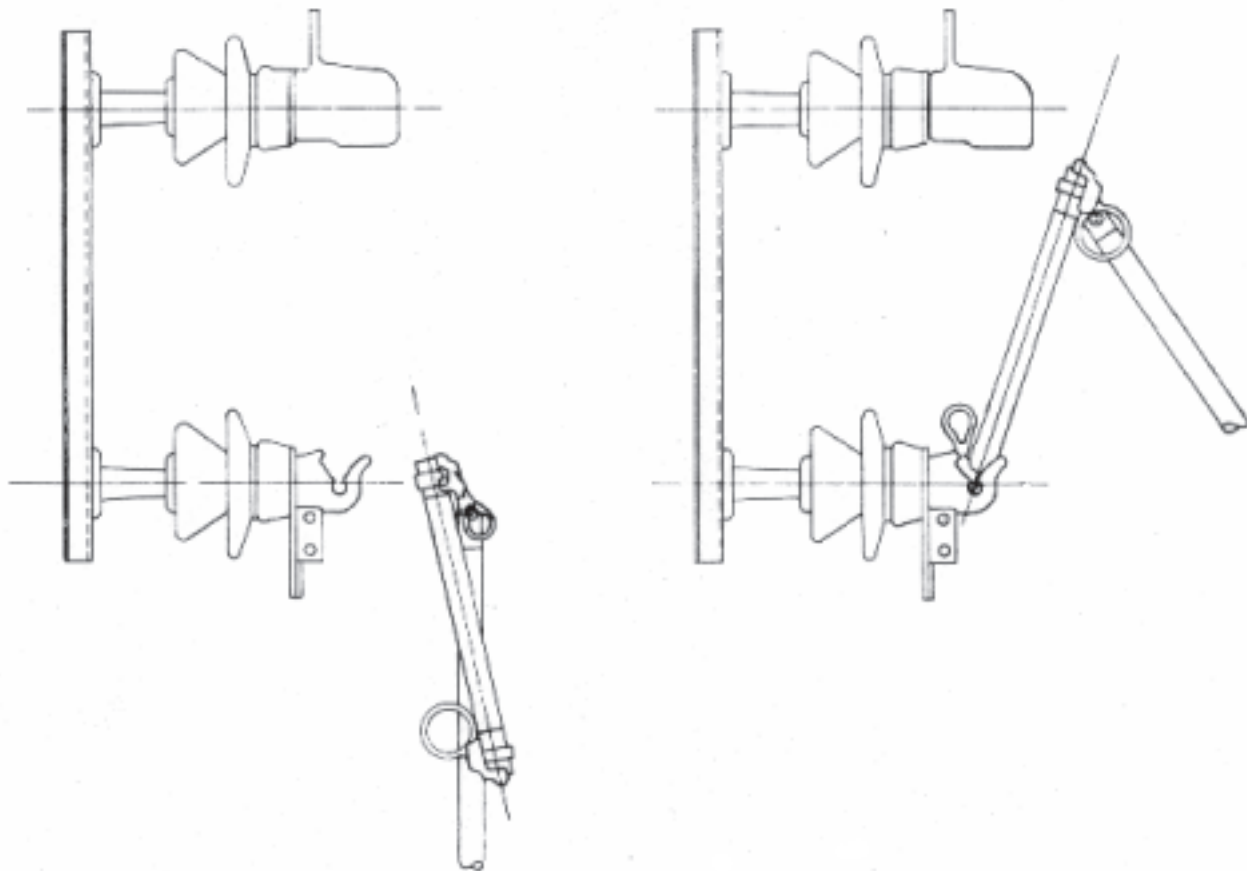

Catalog Number Selection

DBA Fuse Units

2

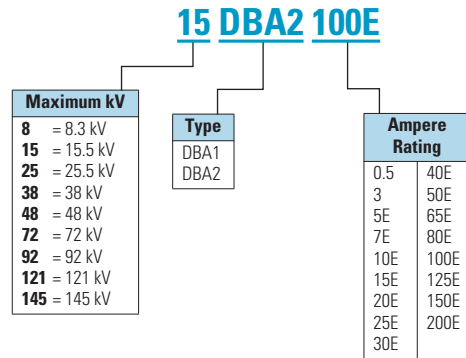

Interrupting Ratings

DBA Fuse Interrupting Ratings

Fuse Unit Maximum Voltage Rating kV	Maximum System Voltage kV	DBA-1 rms Symmetrical kA	DBA-2 rms Symmetrical kA
8.3	2.75	6.3	—
—	5.5	6.3	—
—	8.3	6.3	—
15.5	15.5	6.3	—
25.8	25.8	6.3	12.5
38	38	5.0	12.5
48	48	4.0	12.5
72	72	—	10.0
92	92	—	6.3
121	121	—	5.0
145	145	—	4.0

Product Selection

DBA-1 Type Expulsion Fuse Units

Voltage (kV)				Performance Curves		
Nominal	Maximum	Ampere Rating	Catalog Number	Approximate Shipping Weight Lbs (kg)	Minimum Melting	Total Clearing
7.2	8.3	0.5	8DBA1-0.5	1.5 (0.7)	TC45935101	TC45935201
7.2	8.3	3	8DBA1-3	1.5 (0.7)	TC45935101	TC45935201
7.2	8.3	5E	8DBA1-5E	1.5 (0.7)	TC45935101	TC45935201
7.2	8.3	7E	8DBA1-7E	1.5 (0.7)	TC45935101	TC45935201
7.2	8.3	10E	8DBA1-10E	1.5 (0.7)	TC45935101	TC45935201
7.2	8.3	15E	8DBA1-15E	1.5 (0.7)	TC45935101	TC45935201
7.2	8.3	20E	8DBA1-20E	1.5 (0.7)	TC45935101	TC45935201
7.2	8.3	25E	8DBA1-25E	1.5 (0.7)	TC45935101	TC45935201
7.2	8.3	30E	8DBA1-30E	1.5 (0.7)	TC45935101	TC45935201
7.2	8.3	40E	8DBA1-40E	1.5 (0.7)	TC45935101	TC45935201
7.2	8.3	50E	8DBA1-50E	1.5 (0.7)	TC45935101	TC45935201
7.2	8.3	65E	8DBA1-65E	1.5 (0.7)	TC45935101	TC45935201
7.2	8.3	80E	8DBA1-80E	1.5 (0.7)	TC45935101	TC45935201
7.2	8.3	100E	8DBA1-100E	1.5 (0.7)	TC45935101	TC45935201
7.2	8.3	125E	8DBA1-125E	1.5 (0.7)	TC45935101	TC45935201
7.2	8.3	150E	8DBA1-150E	1.5 (0.7)	TC45935101	TC45935201
7.2	8.3	200E	8DBA1-200E	1.5 (0.7)	TC45935101	TC45935201
14.4	15.5	0.5	15DBA1-0.5	2.1 (1.0)	TC45935101	TC45935201
14.4	15.5	3	15DBA1-3	2.1 (1.0)	TC45935101	TC45935201
14.4	15.5	5E	15DBA1-5E	2.1 (1.0)	TC45935101	TC45935201
14.4	15.5	7E	15DBA1-7E	2.1 (1.0)	TC45935101	TC45935201
14.4	15.5	10E	15DBA1-10E	2.1 (1.0)	TC45935101	TC45935201
14.4	15.5	15E	15DBA1-15E	2.1 (1.0)	TC45935101	TC45935201
14.4	15.5	20E	15DBA1-20E	2.1 (1.0)	TC45935101	TC45935201
14.4	15.5	25E	15DBA1-25E	2.1 (1.0)	TC45935101	TC45935201
14.4	15.5	30E	15DBA1-30E	2.1 (1.0)	TC45935101	TC45935201
14.4	15.5	40E	15DBA1-40E	2.1 (1.0)	TC45935101	TC45935201
14.4	15.5	50E	15DBA1-50E	2.1 (1.0)	TC45935101	TC45935201
14.4	15.5	65E	15DBA1-65E	2.1 (1.0)	TC45935101	TC45935201
14.4	15.5	80E	15DBA1-80E	2.1 (1.0)	TC45935101	TC45935201
14.4	15.5	100E	15DBA1-100E	2.1 (1.0)	TC45935101	TC45935201
14.4	15.5	125E	15DBA1-125E	2.1 (1.0)	TC45935101	TC45935201
14.4	15.5	150E	15DBA1-150E	2.1 (1.0)	TC45935101	TC45935201
14.4	15.5	200E	15DBA1-200E	2.1 (1.0)	TC45935101	TC45935201

DBA-1 Type Expulsion Fuse Units, continued

Voltage (kV)

Performance Curves

2

Nominal	Maximum	Ampere Rating	Catalog Number	Approximate Shipping Weight Lbs (kg)	Minimum Melting	Total Clearing
23	25.5	0.5	25DBA1-0.5	3.1 (1.4)	TC45935101	TC45935201
23	25.5	3	25DBA1-3	3.1 (1.4)	TC45935101	TC45935201
23	25.5	5E	25DBA1-5E	3.1 (1.4)	TC45935101	TC45935201
23	25.5	7E	25DBA1-7E	3.1 (1.4)	TC45935101	TC45935201
23	25.5	10E	25DBA1-10E	3.1 (1.4)	TC45935101	TC45935201
23	25.5	15E	25DBA1-15E	3.1 (1.4)	TC45935101	TC45935201
23	25.5	20E	25DBA1-20E	3.1 (1.4)	TC45935101	TC45935201
23	25.5	25E	25DBA1-25E	3.1 (1.4)	TC45935101	TC45935201
23	25.5	30E	25DBA1-30E	3.1 (1.4)	TC45935101	TC45935201
23	25.5	40E	25DBA1-40E	3.1 (1.4)	TC45935101	TC45935201
23	25.5	50E	25DBA1-50E	3.1 (1.4)	TC45935101	TC45935201
23	25.5	65E	25DBA1-65E	3.1 (1.4)	TC45935101	TC45935201
23	25.5	80E	25DBA1-80E	3.1 (1.4)	TC45935101	TC45935201
23	25.5	100E	25DBA1-100E	3.1 (1.4)	TC45935101	TC45935201
23	25.5	125E	25DBA1-125E	3.1 (1.4)	TC45935101	TC45935201
23	25.5	150E	25DBA1-150E	3.1 (1.4)	TC45935101	TC45935201
23	25.5	200E	25DBA1-200E	3.1 (1.4)	TC45935101	TC45935201
34.5	38	0.5	38DBA1-0.5	4.2 (1.9)	TC45935101	TC45935201
34.5	38	3	38DBA1-3	4.2 (1.9)	TC45935101	TC45935201
34.5	38	5E	38DBA1-5E	4.2 (1.9)	TC45935101	TC45935201
34.5	38	7E	38DBA1-7E	4.2 (1.9)	TC45935101	TC45935201
34.5	38	10E	38DBA1-10E	4.2 (1.9)	TC45935101	TC45935201
34.5	38	15E	38DBA1-15E	4.2 (1.9)	TC45935101	TC45935201
34.5	38	20E	38DBA1-20E	4.2 (1.9)	TC45935101	TC45935201
34.5	38	25E	38DBA1-25E	4.2 (1.9)	TC45935101	TC45935201
34.5	38	30E	38DBA1-30E	4.2 (1.9)	TC45935101	TC45935201
34.5	38	40E	38DBA1-40E	4.2 (1.9)	TC45935101	TC45935201
34.5	38	50E	38DBA1-50E	4.2 (1.9)	TC45935101	TC45935201
34.5	38	65E	38DBA1-65E	4.2 (1.9)	TC45935101	TC45935201
34.5	38	80E	38DBA1-80E	4.2 (1.9)	TC45935101	TC45935201
34.5	38	100E	38DBA1-100E	4.2 (1.9)	TC45935101	TC45935201
34.5	38	125E	38DBA1-125E	4.2 (1.9)	TC45935101	TC45935201
34.5	38	150E	38DBA1-150E	4.2 (1.9)	TC45935101	TC45935201
34.5	38	200E	38DBA1-200E	4.2 (1.9)	TC45935101	TC45935201

DBA-1 Type Expulsion Fuse Units, continued

Voltage (kV)

Performance Curves

Nominal	Maximum	Ampere Rating	Catalog Number	Approximate Shipping Weight Lbs (kg)	Performance Curves	
					Minimum Melting	Total Clearing
46	48	0.5	48DBA1-0.5	6.5 (3.0)	TC45935101	TC45935301
46	48	3	48DBA1-3	6.5 (3.0)	TC45935101	TC45935301
46	48	5E	48DBA1-5E	6.5 (3.0)	TC45935101	TC45935301
46	48	7E	48DBA1-7E	6.5 (3.0)	TC45935101	TC45935301
46	48	10E	48DBA1-10E	6.5 (3.0)	TC45935101	TC45935301
46	48	15E	48DBA1-15E	6.5 (3.0)	TC45935101	TC45935301
46	48	20E	48DBA1-20E	6.5 (3.0)	TC45935101	TC45935301
46	48	25E	48DBA1-25E	6.5 (3.0)	TC45935101	TC45935301
46	48	30E	48DBA1-30E	6.5 (3.0)	TC45935101	TC45935301
46	48	40E	48DBA1-40E	6.5 (3.0)	TC45935101	TC45935301
46	48	50E	48DBA1-50E	6.5 (3.0)	TC45935101	TC45935301
46	48	65E	48DBA1-65E	6.5 (3.0)	TC45935101	TC45935301
46	48	80E	48DBA1-80E	6.5 (3.0)	TC45935101	TC45935301
46	48	100E	48DBA1-100E	6.5 (3.0)	TC45935101	TC45935301
46	48	125E	48DBA1-125E	6.5 (3.0)	TC45935101	TC45935301
46	48	150E	48DBA1-150E	6.5 (3.0)	TC45935101	TC45935301
46	48	200E	48DBA1-200E	6.5 (3.0)	TC45935101	TC45935301
69	72	0.5	72DBA1-0.5	7.1 (3.25)	TC45935101	TC45935301
69	72	3	72DBA1-3	7.1 (3.25)	TC45935101	TC45935301
69	72	5E	72DBA1-5E	7.1 (3.25)	TC45935101	TC45935301
69	72	7E	72DBA1-7E	7.1 (3.25)	TC45935101	TC45935301
69	72	10E	72DBA1-10E	7.1 (3.25)	TC45935101	TC45935301
69	72	15E	72DBA1-15E	7.1 (3.25)	TC45935101	TC45935301
69	72	20E	72DBA1-20E	7.1 (3.25)	TC45935101	TC45935301
69	72	25E	72DBA1-25E	7.1 (3.25)	TC45935101	TC45935301
69	72	30E	72DBA1-30E	7.1 (3.25)	TC45935101	TC45935301
69	72	40E	72DBA1-40E	7.1 (3.25)	TC45935101	TC45935301
69	72	50E	72DBA1-50E	7.1 (3.25)	TC45935101	TC45935301
69	72	65E	72DBA1-65E	7.1 (3.25)	TC45935101	TC45935301
69	72	80E	72DBA1-80E	7.1 (3.25)	TC45935101	TC45935301
69	72	100E	72DBA1-100E	7.1 (3.25)	TC45935101	TC45935301
69	72	125E	72DBA1-125E	7.1 (3.25)	TC45935101	TC45935301
69	72	150E	72DBA1-150E	7.1 (3.25)	TC45935101	TC45935301
69	72	200E	72DBA1-200E	7.1 (3.25)	TC45935101	TC45935301

DBA-2 Type Expulsion Fuse Units

Voltage (kV)

Performance Curves

2

Nominal	Maximum	Ampere Rating	Catalog Number	Approximate Shipping Weight Lbs (kg)	Minimum Melting	Total Clearing
34.5	38	0.5	38DBA2-5	10 (4.6)	TC45935101	TC45935301
34.5	38	3	38DBA2-3	10 (4.6)	TC45935101	TC45935301
34.5	38	5E	38DBA2-5E	10 (4.6)	TC45935101	TC45935301
34.5	38	7E	38DBA2-7E	10 (4.6)	TC45935101	TC45935301
34.5	38	10E	38DBA2-10E	10 (4.6)	TC45935101	TC45935301
34.5	38	15E	38DBA2-15E	10 (4.6)	TC45935101	TC45935301
34.5	38	20E	38DBA2-20E	10 (4.6)	TC45935101	TC45935301
34.5	38	25E	38DBA2-25E	10 (4.6)	TC45935101	TC45935301
34.5	38	30E	38DBA2-30E	10 (4.6)	TC45935101	TC45935301
34.5	38	40E	38DBA2-40E	10 (4.6)	TC45935101	TC45935301
34.5	38	50E	38DBA2-50E	10 (4.6)	TC45935101	TC45935301
34.5	38	65E	38DBA2-65E	10 (4.6)	TC45935101	TC45935301
34.5	38	80E	38DBA2-780E	10 (4.6)	TC45935101	TC45935301
34.5	38	100E	38DBA2-100E	10 (4.6)	TC45935101	TC45935301
34.5	38	125E	38DBA2-125E	10 (4.6)	TC45935101	TC45935301
34.5	38	150E	38DBA2-150E	10 (4.6)	TC45935101	TC45935301
34.5	38	200E	38DBA2-200E	10 (4.6)	TC45935101	TC45935301
46	48	0.5	48DBA2-5	12 (5.5)	TC45935101	TC45935301
46	48	3	48DBA2-3	12 (5.5)	TC45935101	TC45935301
46	48	5E	48DBA2-5E	12 (5.5)	TC45935101	TC45935301
46	48	7E	48DBA2-7E	12 (5.5)	TC45935101	TC45935301
46	48	10E	48DBA2-10E	12 (5.5)	TC45935101	TC45935301
46	48	15E	48DBA2-15E	12 (5.5)	TC45935101	TC45935301
46	48	20E	48DBA2-20E	12 (5.5)	TC45935101	TC45935301
46	48	25E	48DBA2-25E	12 (5.5)	TC45935101	TC45935301
46	48	30E	48DBA2-30E	12 (5.5)	TC45935101	TC45935301
46	48	40E	48DBA2-40E	12 (5.5)	TC45935101	TC45935301
46	48	50E	48DBA2-50E	12 (5.5)	TC45935101	TC45935301
46	48	65E	48DBA2-65E	12 (5.5)	TC45935101	TC45935301
46	48	80E	48DBA2-780E	12 (5.5)	TC45935101	TC45935301
46	48	100E	48DBA2-100E	12 (5.5)	TC45935101	TC45935301
46	48	125E	48DBA2-125E	12 (5.5)	TC45935101	TC45935301
46	48	150E	48DBA2-150E	12 (5.5)	TC45935101	TC45935301
46	48	200E	48DBA2-200E	12 (5.5)	TC45935101	TC45935301

DBA-2 Type Expulsion Fuse Units, continued

Voltage (kV)

Performance Curves

Nominal	Maximum	Ampere Rating	Catalog Number	Approximate Shipping Weight Lbs (kg)	Performance Curves	
					Minimum Melting	Total Clearing
69	72	0.5	72DBA2-5	15 (6.8)	TC45935101	TC45935301
69	72	3	72DBA2-3	15 (6.8)	TC45935101	TC45935301
69	72	5E	72DBA2-5E	15 (6.8)	TC45935101	TC45935301
69	72	7E	72DBA2-7E	15 (6.8)	TC45935101	TC45935301
69	72	10E	72DBA2-10E	15 (6.8)	TC45935101	TC45935301
69	72	15E	72DBA2-15E	15 (6.8)	TC45935101	TC45935301
69	72	20E	72DBA2-20E	15 (6.8)	TC45935101	TC45935301
69	72	25E	72DBA2-25E	15 (6.8)	TC45935101	TC45935301
69	72	30E	72DBA2-30E	15 (6.8)	TC45935101	TC45935301
69	72	40E	72DBA2-40E	15 (6.8)	TC45935101	TC45935301
69	72	50E	72DBA2-50E	15 (6.8)	TC45935101	TC45935301
69	72	65E	72DBA2-65E	15 (6.8)	TC45935101	TC45935301
69	72	80E	72DBA2-780E	15 (6.8)	TC45935101	TC45935301
69	72	100E	72DBA2-100E	15 (6.8)	TC45935101	TC45935301
69	72	125E	72DBA2-125E	15 (6.8)	TC45935101	TC45935301
69	72	150E	72DBA2-150E	15 (6.8)	TC45935101	TC45935301
69	72	200E	72DBA2-200E	15 (6.8)	TC45935101	TC45935301
92	92	3	92DBA2-3	19 (8.7)	TC45935101	TC45935401
92	92	5E	92DBA2-5E	19 (8.7)	TC45935101	TC45935401
92	92	7E	92DBA2-7E	19 (8.7)	TC45935101	TC45935401
92	92	10E	92DBA2-10E	19 (8.7)	TC45935101	TC45935401
92	92	15E	92DBA2-15E	19 (8.7)	TC45935101	TC45935401
92	92	20E	92DBA2-20E	19 (8.7)	TC45935101	TC45935401
92	92	25E	92DBA2-25E	19 (8.7)	TC45935101	TC45935401
92	92	30E	92DBA2-30E	19 (8.7)	TC45935101	TC45935401
92	92	40E	92DBA2-40E	19 (8.7)	TC45935101	TC45935401
92	92	50E	92DBA2-50E	19 (8.7)	TC45935101	TC45935401
92	92	65E	92DBA2-65E	19 (8.7)	TC45935101	TC45935401
92	92	80E	92DBA2-780E	19 (8.7)	TC45935101	TC45935401
92	92	100E	92DBA2-100E	19 (8.7)	TC45935101	TC45935401
92	92	125E	92DBA2-125E	19 (8.7)	TC45935101	TC45935401
92	92	150E	92DBA2-150E	19 (8.7)	TC45935101	TC45935401
92	92	200E	92DBA2-200E	19 (8.7)	TC45935101	TC45935401

DBA-2 Type Expulsion Fuse Units, continued

Voltage (kV)

Performance Curves

2

Nominal	Maximum	Ampere Rating	Catalog Number	Approximate Shipping Weight Lbs (kg)	Minimum Melting	Total Clearing
115	121	3	121DBA2-3	22 (10)	TC45935101	TC45935401
115	121	5E	121DBA2-5E	22 (10)	TC45935101	TC45935401
115	121	7E	121DBA2-7E	22 (10)	TC45935101	TC45935401
115	121	10E	121DBA2-10E	22 (10)	TC45935101	TC45935401
115	121	15E	121DBA2-15E	22 (10)	TC45935101	TC45935401
115	121	20E	121DBA2-20E	22 (10)	TC45935101	TC45935401
115	121	25E	121DBA2-25E	22 (10)	TC45935101	TC45935401
115	121	30E	121DBA2-30E	22 (10)	TC45935101	TC45935401
115	121	40E	121DBA2-40E	22 (10)	TC45935101	TC45935401
115	121	50E	121DBA2-50E	22 (10)	TC45935101	TC45935401
115	121	65E	121DBA2-65E	22 (10)	TC45935101	TC45935401
115	121	80E	121DBA2-780E	22 (10)	TC45935101	TC45935401
115	121	100E	121DBA2-100E	22 (10)	TC45935101	TC45935401
115	121	125E	121DBA2-125E	22 (10)	TC45935101	TC45935401
115	121	150E	121DBA2-150E	22 (10)	TC45935101	TC45935401
115	121	200E	121DBA2-200E	22 (10)	TC45935101	TC45935401
138	145	3	145DBA2-3	25 (11.4)	TC45935101	TC45935401
138	145	5E	145DBA2-5E	25 (11.4)	TC45935101	TC45935401
138	145	7E	145DBA2-7E	25 (11.4)	TC45935101	TC45935401
138	145	10E	145DBA2-10E	25 (11.4)	TC45935101	TC45935401
138	145	15E	145DBA2-15E	25 (11.4)	TC45935101	TC45935401
138	145	20E	145DBA2-20E	25 (11.4)	TC45935101	TC45935401
138	145	25E	145DBA2-25E	25 (11.4)	TC45935101	TC45935401
138	145	30E	145DBA2-30E	25 (11.4)	TC45935101	TC45935401
138	145	40E	145DBA2-40E	25 (11.4)	TC45935101	TC45935401
138	145	50E	145DBA2-50E	25 (11.4)	TC45935101	TC45935401
138	145	65E	145DBA2-65E	25 (11.4)	TC45935101	TC45935401
138	145	80E	145DBA2-780E	25 (11.4)	TC45935101	TC45935401
138	145	100E	145DBA2-100E	25 (11.4)	TC45935101	TC45935401
138	145	125E	145DBA2-125E	25 (11.4)	TC45935101	TC45935401
138	145	150E	145DBA2-150E	25 (11.4)	TC45935101	TC45935401
138	145	200E	145DBA2-200E	25 (11.4)	TC45935101	TC45935401

DBU Fuse Unit in Outdoor Mounting



DBU Type Fuses

Product Description

Introduction

Eaton's DBU (Distribution Boric acid Fuse Unit) power and distribution fuses are expulsion-style fuse units designed for both indoor and outdoor applications. DBU fuse units provide a low initial cost alternative to refillable fuses.

Conventional distribution cutouts use a fuse link in a fiber tube within the fuse holder for fault interruption. DBU fuses far exceed the cutout in interrupting rating, and considerably reduce the hazards and noise produced by the violent exhaust of cutouts under fault interrupting conditions. DBU fuses employ calibrated silver elements with a parallel strain links, boric acid interrupting media, and a spring and rod mechanism, all housed inside a sealed rigid enclosure. The design is optimized to give a low arc voltage and mild exhaust during fault interruption. DBU expulsion fuses are available in three voltage classes: 17 kV, 27 kV, and 38 kV, and in three speed variations: Standard "E", Slow "E", and "K" with amperage sizes ranging from 3A through 200A.

Construction

A DBU fuse comprises the fuse unit, end fittings (including a muffler when installed in an indoor mounting), and a mounting.

Principle parts of the replaceable DBU fuse unit are illustrated in the cross section view of the figure on **Page V14-T2-40**. The active parts of the fuse unit are the calibrated current responsive silver element with a parallel high strength strain wire, arcing rod, boric acid cylinder, and spring. To ensure adequate strength to contain the force of the arc interruption, the assembly is enclosed in a high strength glass-epoxy tube with plated copper end connections. The use of a calibrated pure silver element and Nichrome™ strain wire makes the DBU less prone to premature operation caused by vibration, corona corrosion, or aging of the fuse elements. It is not susceptible to damage by transient faults or overloads that may approach the minimum melt time-current curve point.

Contents

Description

<i>Description</i>	<i>Page</i>
DBU Type Fuses	
Applications	V14-T2-40
Interruption and Protection	V14-T2-41
Testing and Performance	V14-T2-43
Installation	V14-T2-43
Catalog Number Selection	V14-T2-44
Interrupting Ratings	V14-T2-44
Product Selection	V14-T2-45
Dimensions	V14-T2-50

Under normal load conditions, a positive low resistance sliding connection is maintained between the movable arcing rod and the fixed contact at the upper end of the fuse unit with a tulip contact. Durable weatherproof labels are attached to each fuse to provide rating and manufacturer information.

Operation

DBU expulsion fuses use the proven performance of boric acid to create the de-ionizing action needed to interrupt fault currents. Interruption is achieved by the action of the arcing rod and a charged compression spring that elongates the arc through a boric acid chamber when the arcing rod is released by the melting and arcing of the fuse element and strain wire. The high temperature of the arc separates the hydrated boric

acid producing a blast of water vapor and inert boric anhydride. This expanding mixture extinguishes the arc by blasting through and de-ionizing it. At high levels of fault current, the exhaust caused by the interruption ruptures the vent disc and exits from the bottom of the fuse. At lower values of fault current, the interruption is confined within the fuse unit, and there is no exhaust from the fuse. The de-ionizing action prevents the arc from restriking after a current zero.

DBU fuses are designed to interrupt short-circuit currents within 1/2 cycle at the next current zero. The relative details of the boric acid cylinder and the arcing rod and element assemblies are tuned to limit any noise and hazard produced by a fuse operation at all levels of fault current.

2.6

Expulsion Fuses

DBU Type Fuses

2

DBU Sectioned View

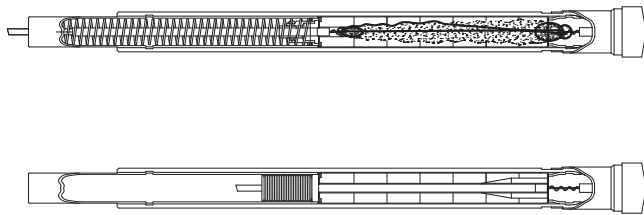

When the fuse operates, the spring forces the top of the arcing rod to penetrate the upper seal. On indoor applications, this action causes the visible blown fuse indicator to actuate.

On outdoor installations, the latch releases the fuse unit allowing the ejector spring to move the assembly outward and swing into the vertical down dropout position. This dropout action provides immediate visual indication that the fuse has interrupted a fault. When a fuse has operated and the dropout action is complete, the fuse unit complete with end fittings can be removed with a switch stick. Refer to I.L.36-642-E for Installation Instructions.

Applications

DBU fuses provide effective protection for circuits and equipment that operate on systems with voltage ratings up to 34,500V. They can be used on both electric utility and industrial distribution systems and are suitable for use on the following:

- Power transformers
- Feeder circuits
- Distribution transformers
- Potential transformers
- Station service transformers
- Metal-enclosed switchgear
- Pad mount switches

DBU fuse units are sealed and can be used in outdoor or indoor applications. They can be used to directly replace competitive equivalent units.

DBU Fuse Unit

A DBU fuse unit is comprised of a compression spring, an arcing rod, a calibrated

DBU fuse units have reliable performance in compliance with industry-standard time-current characteristics which allow close coordination that other DBU fuses, as well as other fuses and a wide variety of other protective devices.

DBU fuses operate promptly to limit the stress on electrical systems due to short-circuits. They isolate the faulted circuit, limiting service interruptions. They act rapidly to take transformers off-line, preventing tank rupture, and feeder circuits off-line before damage can become widespread. They also provide excellent isolation for capacitors, preventing case failure in the event of a fault condition.

When installed on the primary side of substation power transformers, DBU fuses provide protection against small, medium or large faults. Regardless of the nature of the fault, full protection is provided even down to minimum melt current.

DBU Details

Eaton's DBU fuses provide superior performance and are applicable for distribution system protection up to an operational voltage of 34.5KV. Because DBU fuses are available in a range of current and speed ratings, close fusing can be achieved to maximize protection and overall coordination. The quality of the DBU design and manufacturing process ensures repeatable accuracy and ongoing time-current protection.

current responsive silver element with a parallel mechanical strain wire that isolates the silver element from the spring tension, and a

solid boric acid liner that assists with the interruption. All of these components are contained within a high strength glass-epoxy tube sealed with high conductivity copper end contacts that are compatible with industry standard end fittings for indoor or outdoor application. The calibrated fuse element determines the operational fault response characteristics of the fuse unit, which are indicated on the specific time-current characteristic curve.

The heavy copper cylindrical arcing rod is contained within the boric acid liner and performs two functions. Under normal conditions, it conducts the continuous rated current of the fuse. When the fuse element and strain wire melt during a fault condition, the arcing rod draws and lengthens the arc as it moves up through the boric acid liner. This movement is caused by spring tension accelerating the arcing rod after release by the melted strain link.

Intense heat from the arc separates the hydrated boric acid producing water vapor and inert boric anhydride that extinguishes and de-ionizes the arc.

On low current interruptions, the vent diaphragm is not ruptured, and the pressure retained within the fuse unit helps to extinguish the low intensity arc. On high current interruptions, the vent diaphragm is ruptured and the exhaust exits from the bottom of the fuse.

In either case, the resulting dielectric strength generated in the fuse unit prevents reignition of the arc after a current zero.

DBU fuse units are discarded after fault interruption, and do not present any environmental hazard if discarded in a landfill.

DBU End Fittings

End fittings that are positioned on the top and bottom of the fuse unit and are required to complete the electrical connection between the fuse unit and mounting, can be reused if they remain undamaged. They are completely interchangeable with other comparable industry standard end fittings.

Outdoor End Fittings

Reusable outdoor end fittings are silver plated and made of a cast high conductivity copper alloy. The hookeye in the lower end fitting allows the fuse unit to be easily lifted in or out of the lower hinge contact of the mounting. A large hookeye on the upper fitting allows for easy operation in pole-top mountings with a switch stick. The design of the upper end fitting provides for proper engagement in the upper contact assembly of the mounting. The positive locking action of the latch mechanism prevents detachment from the mounting due to shock or vibration. The lower end fitting has two cylindrical posts that insert into the lower contact assembly of the mounting. These posts allow the fuse to rotate into the proper engaged position, and suspend the fuse in the operated, drop-out position. If a fault occurs, the arcing rod will pierce the seal at the upper end of the fuse unit, and cause the latch to release. Once released, the fuse will rotate down into the drop-out position to indicate that the fuse has operated.

Indoor End Fittings

Reusable indoor end fittings are composed of high-impact plastic and high conductivity copper alloy. The visual indicator located on the top end fitting, provides clear indication of a fuse unit that has operated. The silver-plated contact rod insures positive conductivity between the fuse unit and the upper contact assembly of the mounting.

The spring-biased plastic latch hookkey actuates the latch mechanism when engaged into the mounting. It readily accepts a switch stick to insert or remove the assembled fuse unit. A locating pin in the upper end fitting assembly ensures proper alignment and engagement with the fuse unit. The cast bottom indoor end fitting has a locating slot on the inside bore that aligns with a locating pin on the lower section of the fuse unit to provide proper alignment with the mounting.

The bottom indoor end fitting is attached to the fuse unit by threading a muffler into the end fitting, and so clamping the fitting to the fuse unit. Projections on the bottom of the muffler allow sufficient torque to be applied to seal the muffler to the fuse unit. The lower ferrule of the fuse unit directly contacts the lower contacts of the mounting. The muffler absorbs noise and contamination from arcing products to prevent contamination of indoor equipment. The muffler is constructed of a plated steel housing, containing copper mesh screening. This copper mesh acts to absorb and contain the noise, and de-ionize exhaust materials of the fuse during a fault interruption. De-ionizing the exhaust gases prevents accidental flashover from phase-to-phase or phase-to-ground by limiting foreign airborne particles and gases.

Mountings and Live Parts

Eaton offers a full line of outdoor mountings [Ⓢ] and indoor loadbreak and non-loadbreak mountings and live parts for the DBU fuse family. Mountings are available in 17 kV, 27 kV, and 38 kV class designs, and these mountings will readily accommodate DBU fuses and other equivalent industry standard fuses. DBU mountings have a rated maximum continuous current of 200A, with a rated maximum interrupting current up to 14 kA. The following lists the LIWV rated lightning impulse withstand voltage rating of each voltage class (BIL):

- 17 kV–95 kV
- 27 kV–125 kV
- 38 kV–150 kV

Indoor loadbreak units have a maximum three-time fault close ASYM of 22,400A rms. Refer to the catalog number section for exact ratings per unit. Indoor mountings are constructed with rigid steel bases that are powder coated and baked. Bases are supplied with preformed mounting holes for easy installation.

Insulators are molded of high strength epoxy material for superior insulating characteristics. Live parts are rigidly secured to the insulators with standard mounting hardware.

Both left and right side cable terminations are available for indoor mountings for proper installation spacing. All bus connections are plated copper for improved conductivity and endurance.

All loadbreak units have a three-time fault close rating. These fuse mountings can withstand a fuse assembly being closed into a fault of the magnitude specified three times when closed briskly without hesitation, and remain operable and able to carry and interrupt the

continuous current. All live parts are constructed of silver-plated copper to ensure maximum and sustained conductivity.

Live parts can be purchased as separate kits without mountings.

Interruption and Protection

DBU fuses provide effective protection for circuits and equipment operating on voltages from 2400V through 34,500V. They are designed to carry their rated continuous current without exceeding the temperature rise limits specified in IEEE and ANSI standards.

Under normal conditions, the temperature of the fusible element is well below the melting temperature and does not melt.

Under overload conditions, when the current is above any allowable overload condition for an extended period of time, but below the minimum level of current indicated on the total clearing time-current curve, the element temperature is below the melting temperature, but the heat generated within the fuse unit may be sufficient to cause permanent degradation of the structure of the fuse unit, sufficient to interfere with the ability of the fuse unit to perform as designed.

Under fault conditions, when a fault occurs that is large enough to melt the fuse element, an arc is initiated and elongated by the spring, pulling the arcing rod up into the boric acid interrupting media. The heat produced separates the material of the boric acid liner producing water vapor and boric anhydride that de-ionize the arc. At low fault current levels the pressure in the arcing chamber along with the elongation of the arc gives sufficient dielectric strength to extinguish the arc at a natural current zero without

bursting the pressure diaphragm. At higher fault current levels, the by-products extinguish the arc at a natural current zero by bursting the pressure diaphragm and forcing the arc products out of the bottom of the fuse unit. When installed indoors, the exhaust and noise produced during the interruption process are limited by the muffler attached to the lower end fitting. When installed outdoors, the arc products are exhausted.

During the interrupting process, current continues to flow in the circuit and in the fuse until a current zero is reached. When the arc is extinguished at current zero, the voltage across the fuse will attempt to re-ignite the arc. The voltage across the fuse immediately after the voltage zero is the sum of the circuit power frequency recovery voltage and a high frequency oscillatory voltage controlled by the circuit inductance and stray capacitance. This high frequency oscillatory voltage is called the Transient Recovery Voltage (TRV). After the fuse has interrupted a fault current at a natural circuit current zero, the dielectric gap must withstand this combined voltage to prevent re-ignition of the arc for a successful interruption to occur.

The rated maximum voltage of a DBU fuse is the highest rms voltage at which the fuse is designed to operate. The dielectric withstand level corresponds to insulation levels of power class and distribution class equipment, as DBU fuses can be used in either environment. Maximum voltage ratings for DBU fuses are: 17 kV, 27 kV, and 38 kV.

Note

- Ⓢ Outdoor mountings available for 17 kV and 27 kV.

2.6

Expulsion Fuses

DBU Type Fuses

2

Fuses should never be applied where the available fault current exceeds the rated maximum interrupting current of the fuse, or the maximum value of the power frequency system voltage exceeds the rated maximum voltage of the fuse.

The rated maximum interrupting current values for DBU fuses are listed on **Page V14-T2-44**.

The continuous current rating of a DBU power fuse should equal or exceed the maximum load current where the fuse is applied.

DBU fuse units are available with continuous current ratings up to 200A and are designated as either E- or K-rated. These designations are defined in ANSI/IEEE Std. C37.42™ and C37.46™.

Coordination Consideration

Coordination considerations must be made to help determine what type of fuse is applied. The DBU power fuse interrupts at a natural current zero in the current wave and allows a minimum of a half cycle of fault current to flow before the fault is cleared. The time-current characteristics associated with a DBU has a rather gradual slope making it easier to coordinate with downstream equipment. In addition, the DBU is ideal for higher voltage (up to 38 kV) and high current applications (through 200A). It is important to examine the minimum melting and total clearing time-current characteristics of this particular fuse.

The melting time is the time in seconds required to melt the fuse element. This curve indicates when or even if the element of the fuse will melt for different symmetrical current magnitudes.

The total clearing time is the total amount of time it takes to clear a fault once the element has melted. The total clearing time is really the sum of the melting time and the time the fuse arcs during the clearing process. The DBU power fuse is offered in three configurations for use with high currents: “E” (Standard), “K” (Fast) and “SE” (Slow). The curves for the SE are less inverse and allow for more of a time delay at high currents.

Finally, low currents, usually referred to as overload currents, must also be considered. The DBU and other expulsion fuses have a rather low thermal capacity and cannot carry overloads of the same magnitude and duration as motors and transformers of equal continuous currents. For this reason, the fuse must be sized with the full load current in mind. This consideration should be made so the fuse does not blow on otherwise acceptable overloads and inrush conditions.

The Eaton DBU family of power fuses is broad and comprehensive. Refer to the table below to review the ratings available for most application requirements. The final selection process for new applications will include the fuse unit, end fittings, and a mounting.

DBU Power Fuse Short-Circuit Interrupting Ratings

Nominal kV	System	Interrupting Amperes		Interrupting mVA
		Symmetrical Based on X/R = 16	Asymmetrical	(Three-Phase Symmetrical) Where X/R = 16
17	7.2	14,000	22,400	175
	4.8/8.32Y			200
	7.2/12.47Y			300
	7.62/13.2Y			320
	13.8			335
	14.4			350
	16.5			400
27	7.2/12.47Y	12,500	20,000	270
	7.62/13.2Y			285
	13.8			300
	14.4			310
	16.5			365
	23.0			500
	14.4/24.9Y			540
	20/34.5Y ^①			—
38	23.0	10,000	16,000	—
	14.4/24.9Y			—
	27.6			475
	20/34.5Y			600
	34.5			600

Note

^① Applies to 23 kV single-insulator style only, for the protection of single-phase-to-neutral circuits (line or transformers) and three-phase transformers or banks with solidly grounded neutral connections.

Testing and Performance

- Standards
- Testing
- Quality standards

Eaton does not compromise when performance, quality and safety are involved. Exacting standards have been established relative to the design, testing and application of expulsion type power fuses. Compliance with these standards ensures the best selection and performance. DBU type power fuses are designed and tested to applicable portions of ANSI standards as well as other industry standards. The ANSI standards are Consensus Standards jointly formulated by IEEE and NEMA.

IEEE (Institute of Electrical and Electronic Engineers) is an objective technical organization made up of manufacturers, users and other general interest parties. NEMA (National Electrical Manufacturers Association) is an electrical equipment manufacturer only organization with members like Eaton. ANSI (American National Standards Institute) is a nonprofit, privately funded membership organization that coordinates the development of U.S. voluntary national standards. It is also the U.S. member body to the non-treaty international standards

bodies, such as International Organization for Standardization (ISO) and the International Electrotechnical Commission (IEC).

The specific standards associated with DBU power fuses are:

- ANSI C37.40—Service Conditions and Definitions
- ANSI C37.41—Power Fuse Design and Testing
- ANSI C37.42—Distribution Fuse Ratings and Specification
- ANSI C37.46—Power Fuse Ratings and Specifications
- ANSI ~37.48—Power Fuse Application, Operation and Maintenance

Testing

DBU power fuse unit design testing was performed on standard production fuses, holders, mountings and accessories. Demanding tests were performed by Eaton Technical Support and also at recognized independent power testing laboratories. Thermal and interrupting testing was conducted at 17, 27, and 38 kV levels. The entire series of tests was conducted in a specific sequence as stipulated by governing standards without any maintenance being performed.

All test results are verified by laboratory tabulations and oscillogram plots.

Quality

Every effort is made to ensure the delivery of quality fuse units and customer satisfaction. All Eaton fuses are completely inspected at each manufacturing stage. In addition to ongoing quality control inspections, testing is performed prior to shipment. A Micro-Ohm Resistance Test is performed on each fuse to assure proper element construction, alignment and tightness of electrical connections. Construction integrity testing is also performed on every unit.

Each DBU fuse unit is checked to ensure that all items are supplied in keeping with manufacturing drawings. Individual fuses are packed in a plastic bag and then put into individual cartons. In addition, fuses are overpacked in a shipping carton to prevent shipping damage. Finally, mountings are packaged in heavy cardboard containers with reinforced wooden bases.

Installation

Installation instructions are contained within I.L. 36-642.

2.6

Expulsion Fuses

DBU Type Fuses

Catalog Number Selection

2

DBU Fuse Units

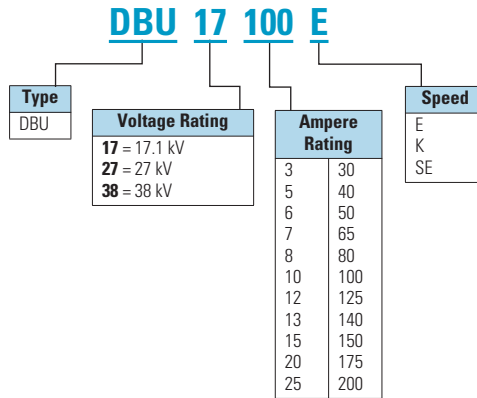

DBU Mounting Catalog Numbers

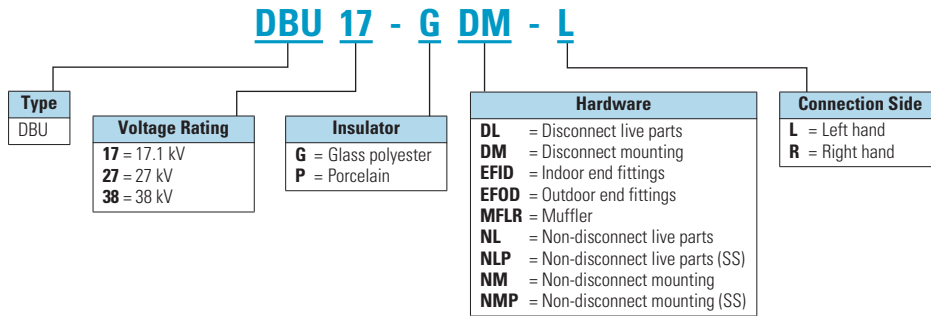

Interrupting Ratings

DBU Fuse Interrupting Ratings

Fuse Unit	Maximum Rated Voltage kV	Maximum System Voltage kV	Outdoor Vented rms Symmetrical kA	Indoor with Muffler rms Symmetrical kA
17.1	17.1	17.1	14.0	14.0
27	27	27	12.5	12.5
38	38	38	10.0	8.5

Product Selection

DBU17 Type Standard E Speed Expulsion Fuse Units

Voltage (kV)					Performance Curves	
Nominal	Maximum	Ampere Rating	Catalog Number	Approximate Shipping Weight Lbs (kg)	Minimum Melting	Total Clearing
14.4	17.1	5	DBU17-5E	2.1 (1.0)	TC66702701	TC66703001
14.4	17.1	7	DBU17-7E	2.1 (1.0)	TC66702701	TC66703001
14.4	17.1	10	DBU17-10E	2.1 (1.0)	TC66702701	TC66703001
14.4	17.1	13	DBU17-13E	2.1 (1.0)	TC66702701	TC66703001
14.4	17.1	15	DBU17-15E	2.1 (1.0)	TC66702701	TC66703001
14.4	17.1	20	DBU17-20E	2.1 (1.0)	TC66702701	TC66703001
14.4	17.1	25	DBU17-25E	2.1 (1.0)	TC66702701	TC66703001
14.4	17.1	30	DBU17-30E	2.1 (1.0)	TC66702701	TC66703001
14.4	17.1	40	DBU17-40E	2.1 (1.0)	TC66702701	TC66703001
14.4	17.1	50	DBU17-50E	2.1 (1.0)	TC66702701	TC66703001
14.4	17.1	65	DBU17-65E	2.1 (1.0)	TC66702701	TC66703001
14.4	17.1	80	DBU17-80E	2.1 (1.0)	TC66702701	TC66703001
14.4	17.1	100	DBU17-100E	2.1 (1.0)	TC66702701	TC66703001
14.4	17.1	125	DBU17-125E	2.1 (1.0)	TC66702701	TC66703001
14.4	17.1	150	DBU17-150E	2.1 (1.0)	TC66702701	TC66703001
14.4	17.1	175	DBU17-175E	2.1 (1.0)	TC66702701	TC66703001
14.4	17.1	200	DBU17-200E	2.1 (1.0)	TC66702701	TC66703001

DBU17 Type K Speed Expulsion Fuse Units

Voltage (kV)					Performance Curves	
Nominal	Maximum	Ampere Rating	Catalog Number	Approximate Shipping Weight Lbs (kg)	Minimum Melting	Total Clearing
14.4	17.1	3	DBU17-3K	2.1 (1.0)	TC66702801	TC66703101
14.4	17.1	6	DBU17-6K	2.1 (1.0)	TC66702801	TC66703101
14.4	17.1	8	DBU1780K	2.1 (1.0)	TC66702801	TC66703101
14.4	17.1	10	DBU17-10K	2.1 (1.0)	TC66702801	TC66703101
14.4	17.1	12	DBU17-12K	2.1 (1.0)	TC66702801	TC66703101
14.4	17.1	15	DBU17-15K	2.1 (1.0)	TC66702801	TC66703101
14.4	17.1	20	DBU17-20K	2.1 (1.0)	TC66702801	TC66703101
14.4	17.1	25	DBU17-25K	2.1 (1.0)	TC66702801	TC66703101
14.4	17.1	30	DBU17-30K	2.1 (1.0)	TC66702801	TC66703101
14.4	17.1	40	DBU17-40K	2.1 (1.0)	TC66702801	TC66703101
14.4	17.1	50	DBU17-50K	2.1 (1.0)	TC66702801	TC66703101
14.4	17.1	65	DBU17-65K	2.1 (1.0)	TC66702801	TC66703101
14.4	17.1	80	DBU17-80K	2.1 (1.0)	TC66702801	TC66703101
14.4	17.1	100	DBU17-100K	2.1 (1.0)	TC66702801	TC66703101
14.4	17.1	140	DBU17-140K	2.1 (1.0)	TC66702801	TC66703101
14.4	17.1	200	DBU17-200K	2.1 (1.0)	TC66702801	TC66703101

2.6

Expulsion Fuses

DBU Type Fuses

2

DBU17 Type Slow E Speed Expulsion Fuse Units

Voltage (kV)

Performance Curves

Nominal	Maximum	Ampere Rating	Catalog Number	Approximate Shipping Weight Lbs (kg)	Minimum Melting	Total Clearing
14.4	17.1	15	DBU17-15SE	2.1 (1.0)	TC66702601	TC66702901
14.4	17.1	20	DBU17-20SE	2.1 (1.0)	TC66702601	TC66702901
14.4	17.1	25	DBU17-25SE	2.1 (1.0)	TC66702601	TC66702901
14.4	17.1	30	DBU17-30SE	2.1 (1.0)	TC66702601	TC66702901
14.4	17.1	40	DBU17-40SE	2.1 (1.0)	TC66702601	TC66702901
14.4	17.1	50	DBU17-50SE	2.1 (1.0)	TC66702601	TC66702901
14.4	17.1	65	DBU17-65SE	2.1 (1.0)	TC66702601	TC66702901
14.4	17.1	80	DBU17-80SE	2.1 (1.0)	TC66702601	TC66702901
14.4	17.1	100	DBU17-100SE	2.1 (1.0)	TC66702601	TC66702901
14.4	17.1	125	DBU17-125SE	2.1 (1.0)	TC66702601	TC66702901
14.4	17.1	150	DBU17-150SE	2.1 (1.0)	TC66702601	TC66702901
14.4	17.1	175	DBU17-175SE	2.1 (1.0)	TC66702601	TC66702901
14.4	17.1	200	DBU17-200SE	2.1 (1.0)	TC66702601	TC66702901

DBU27 Type Standard E Speed Expulsion Fuse Units

Voltage (kV)

Performance Curves

Nominal	Maximum	Ampere Rating	Catalog Number	Approximate Shipping Weight Lbs (kg)	Minimum Melting	Total Clearing
23	27	5	DBU27-5E	2.5 (1.15)	TC66702701	TC66703901
23	27	7	DBU27-7E	2.5 (1.15)	TC66702701	TC66703901
23	27	10	DBU27-10E	2.5 (1.15)	TC66702701	TC66703901
23	27	13	DBU27-13E	2.5 (1.15)	TC66702701	TC66703901
23	27	15	DBU27-15E	2.5 (1.15)	TC66702701	TC66703901
23	27	20	DBU27-20E	2.5 (1.15)	TC66702701	TC66703901
23	27	25	DBU27-25E	2.5 (1.15)	TC66702701	TC66703901
23	27	30	DBU27-30E	2.5 (1.15)	TC66702701	TC66703901
23	27	40	DBU27-40E	2.5 (1.15)	TC66702701	TC66703901
23	27	50	DBU27-50E	2.5 (1.15)	TC66702701	TC66703901
23	27	65	DBU27-65E	2.5 (1.15)	TC66702701	TC66703901
23	27	80	DBU27-80E	2.5 (1.15)	TC66702701	TC66703901
23	27	100	DBU27-100E	2.5 (1.15)	TC66702701	TC66703901
23	27	125	DBU27-125E	2.5 (1.15)	TC66702701	TC66703901
23	27	150	DBU27-150E	2.5 (1.15)	TC66702701	TC66703901
23	27	175	DBU27-175E	2.5 (1.15)	TC66702701	TC66703901
23	27	200	DBU27-200E	2.5 (1.15)	TC66702701	TC66703901

DBU27 Type K Speed Expulsion Fuse Units

Voltage (kV)

Nominal	Maximum	Ampere Rating	Catalog Number	Approximate Shipping Weight Lbs (kg)	Performance Curves	
					Minimum Melting	Total Clearing
23	27	3	DBU27-3K	2.5 (1.15)	TC66702801	TC66704001
23	27	6	DBU27-6K	2.5 (1.15)	TC66702801	TC66704001
23	27	8	DBU27-8K	2.5 (1.15)	TC66702801	TC66704001
23	27	10	DBU27-10K	2.5 (1.15)	TC66702801	TC66704001
23	27	12	DBU27-12K	2.5 (1.15)	TC66702801	TC66704001
23	27	15	DBU27-15K	2.5 (1.15)	TC66702801	TC66704001
23	27	20	DBU27-20K	2.5 (1.15)	TC66702801	TC66704001
23	27	25	DBU27-25K	2.5 (1.15)	TC66702801	TC66704001
23	27	30	DBU27-30K	2.5 (1.15)	TC66702801	TC66704001
23	27	40	DBU27-40K	2.5 (1.15)	TC66702801	TC66704001
23	27	50	DBU27-50K	2.5 (1.15)	TC66702801	TC66704001
23	27	65	DBU27-65K	2.5 (1.15)	TC66702801	TC66704001
23	27	80	DBU27-80K	2.5 (1.15)	TC66702801	TC66704001
23	27	100	DBU27-100K	2.5 (1.15)	TC66702801	TC66704001
23	27	140	DBU27-140K	2.5 (1.15)	TC66702801	TC66704001
23	27	200	DBU27-200K	2.5 (1.15)	TC66702801	TC66704001

DBU27 Type Slow E Speed Expulsion Fuse Units

Voltage (kV)

Nominal	Maximum	Ampere Rating	Catalog Number	Approximate Shipping Weight Lbs (kg)	Performance Curves	
					Minimum Melting	Total Clearing
23	27	15	DBU27-15SE	2.5 (1.15)	TC66702601	TC66703801
23	27	20	DBU27-20SE	2.5 (1.15)	TC66702601	TC66703801
23	27	25	DBU27-25SE	2.5 (1.15)	TC66702601	TC66703801
23	27	30	DBU27-30SE	2.5 (1.15)	TC66702601	TC66703801
23	27	40	DBU27-40SE	2.5 (1.15)	TC66702601	TC66703801
23	27	50	DBU27-50SE	2.5 (1.15)	TC66702601	TC66703801
23	27	65	DBU27-65SE	2.5 (1.15)	TC66702601	TC66703801
23	27	80	DBU27-80SE	2.5 (1.15)	TC66702601	TC66703801
23	27	100	DBU27-100SE	2.5 (1.15)	TC66702601	TC66703801
23	27	125	DBU27-125SE	2.5 (1.15)	TC66702601	TC66703801
23	27	150	DBU27-150SE	2.5 (1.15)	TC66702601	TC66703801
23	27	175	DBU27-175SE	2.5 (1.15)	TC66702601	TC66703801
23	27	200	DBU27-200SE	2.5 (1.15)	TC66702601	TC66703801

2.6

Expulsion Fuses

DBU Type Fuses

2

DBU38 Type Standard E Speed Expulsion Fuse Units

Voltage (kV)

Performance Curves

Nominal	Maximum	Ampere Rating	Catalog Number	Approximate Shipping Weight Lbs (kg)	Minimum Melting	Total Clearing
34.5	38	5	DBU38-5E	2.8 (1.3)	TC66702701	TC66703901
34.5	38	7	DBU38-7E	2.8 (1.3)	TC66702701	TC66703901
34.5	38	10	DBU38-10E	2.8 (1.3)	TC66702701	TC66703901
34.5	38	13	DBU38-13E	2.8 (1.3)	TC66702701	TC66703901
34.5	38	15	DBU38-15E	2.8 (1.3)	TC66702701	TC66703901
34.5	38	20	DBU38-20E	2.8 (1.3)	TC66702701	TC66703901
34.5	38	25	DBU38-25E	2.8 (1.3)	TC66702701	TC66703901
34.5	38	30	DBU38-30E	2.8 (1.3)	TC66702701	TC66703901
34.5	38	40	DBU38-40E	2.8 (1.3)	TC66702701	TC66703901
34.5	38	50	DBU38-50E	2.8 (1.3)	TC66702701	TC66703901
34.5	38	65	DBU38-65E	2.8 (1.3)	TC66702701	TC66703901
34.5	38	80	DBU38-80E	2.8 (1.3)	TC66702701	TC66703901
34.5	38	100	DBU38-100E	2.8 (1.3)	TC66702701	TC66703901
34.5	38	125	DBU38-125E	2.8 (1.3)	TC66702701	TC66703901
34.5	38	150	DBU38-150E	2.8 (1.3)	TC66702701	TC66703901
34.5	38	175	DBU38-175E	2.8 (1.3)	TC66702701	TC66703901
34.5	38	200	DBU38-200E	2.8 (1.3)	TC66702701	TC66703901

DBU38 Type K Speed Expulsion Fuse Units

Voltage (kV)

Performance Curves

Nominal	Maximum	Ampere Rating	Catalog Number	Approximate Shipping Weight Lbs (kg)	Minimum Melting	Total Clearing
34.5	38	3	DBU38-3K	2.8 (1.3)	TC66702801	TC66704001
34.5	38	6	DBU38-6K	2.8 (1.3)	TC66702801	TC66704001
34.5	38	8	DBU38-8K	2.8 (1.3)	TC66702801	TC66704001
34.5	38	10	DBU38-10K	2.8 (1.3)	TC66702801	TC66704001
34.5	38	12	DBU38-12K	2.8 (1.3)	TC66702801	TC66704001
34.5	38	15	DBU38-15K	2.8 (1.3)	TC66702801	TC66704001
34.5	38	20	DBU38-20K	2.8 (1.3)	TC66702801	TC66704001
34.5	38	25	DBU38-25K	2.8 (1.3)	TC66702801	TC66704001
34.5	38	30	DBU38-30K	2.8 (1.3)	TC66702801	TC66704001
34.5	38	40	DBU38-40K	2.8 (1.3)	TC66702801	TC66704001
34.5	38	50	DBU38-50K	2.8 (1.3)	TC66702801	TC66704001
34.5	38	65	DBU38-65K	2.8 (1.3)	TC66702801	TC66704001
34.5	38	80	DBU38-80K	2.8 (1.3)	TC66702801	TC66704001
34.5	38	100	DBU38-100K	2.8 (1.3)	TC66702801	TC66704001
34.5	38	140	DBU38-140K	2.8 (1.3)	TC66702801	TC66704001
34.5	38	200	DBU38-200K	2.8 (1.3)	TC66702801	TC66704001

DBU38 Type Slow E Expulsion Fuse Units

Voltage (kV)					Performance Curves	
Nominal	Maximum	Ampere Rating	Catalog Number	Approximate Shipping Weight Lbs (kg)	Minimum Melting	Total Clearing
34.5	38	15	DBU38-15SE	2.8 (1.3)	TC66702601	TC66703801
34.5	38	20	DBU38-20SE	2.8 (1.3)	TC66702601	TC66703801
34.5	38	25	DBU38-25SE	2.8 (1.3)	TC66702601	TC66703801
34.5	38	30	DBU38-30SE	2.8 (1.3)	TC66702601	TC66703801
34.5	38	40	DBU38-40SE	2.8 (1.3)	TC66702601	TC66703801
34.5	38	50	DBU38-50SE	2.8 (1.3)	TC66702601	TC66703801
34.5	38	65	DBU38-65SE	2.8 (1.3)	TC66702601	TC66703801
34.5	38	80	DBU38-80SE	2.8 (1.3)	TC66702601	TC66703801
34.5	38	100	DBU38-100SE	2.8 (1.3)	TC66702601	TC66703801
34.5	38	125	DBU38-125SE	2.8 (1.3)	TC66702601	TC66703801
34.5	38	150	DBU38-150SE	2.8 (1.3)	TC66702601	TC66703801
34.5	38	175	DBU38-175SE	2.8 (1.3)	TC66702601	TC66703801
34.5	38	200	DBU38-200SE	2.8 (1.3)	TC66702601	TC66703801

DBU Type Fuse Mountings and Accessories Indoor Applications

Voltage (kV)			Non-Loadbreak Mountings		Loadbreak Mountings		End Fittings		Muffler	Connection
Nominal	Maximum	Ampere Rating	Catalog Number	Catalog Number	Catalog Number	Catalog Number	Catalog Number	Catalog Number		
14.4	17.1	3-200	DBU17-GNM-L	DBU17-NL-L	DBU17-GDM-L	DBU17-DL-L	DBU-EFID	DBU-MFLR	Left hand connections	
14.4	17.1	3-200	DBU17-GNM-R	DBU17-NL-R	DBU17-GDM-R	DBU17-DL-R	DBU-EFID	DBU-MFLR	Right hand connections	
14.4	17.1	3-200	DBU17-GNMP-L	DBU17-NLP-L	—	—	DBU-EFID	DBU-MFLR	Left hand connections stainless steel hardware	
14.4	17.1	3-200	DBU17-GNMP-R	DBU17-NLP-R	—	—	DBU-EFID	DBU-MFLR	Right hand connections stainless steel hardware	
23	27	3-200	DBU27-GNM-L	DBU27-NL-L	DBU27-GDM-L	DBU27-DL-L	DBU-EFID	DBU-MFLR	Left hand connections	
23	27	3-200	DBU27-GNM-R	DBU27-NL-R	DBU27-GDM-R	DBU27-DL-R	DBU-EFID	DBU-MFLR	Right hand connections	
23	27	3-200	DBU27-GNMP-L	DBU27-NLP-L	—	—	DBU-EFID	DBU-MFLR	Left hand connections stainless steel hardware	
23	27	3-200	DBU27-GNMP-R	DBU27-NLP-R	—	—	DBU-EFID	DBU-MFLR	Right hand connections stainless steel hardware	
34.5	38	3-200	DBU38-GNM-L	DBU38-NL-L	—	—	DBU-EFID	DBU-MFLR	Left hand connections	
34.5	38	3-200	DBU38-GNM-R	DBU38-NL-R	—	—	DBU-EFID	DBU-MFLR	Right hand connections	
34.5	38	3-200	DBU38-GNMP-L	DBU38-NLP-L	—	—	DBU-EFID	DBU-MFLR	Left hand connections stainless steel hardware	
34.5	38	3-200	DBU38-GNMP-R	DBU38-NLP-R	—	—	DBU-EFID	DBU-MFLR	Right hand connections stainless steel hardware	

DBU Type Fuse Mountings and Accessories Outdoor Applications

Voltage (kV)			Non-Loadbreak Mountings	End Fittings
Nominal	Maximum	Ampere Rating	Catalog Number	Catalog Number
14.4	17.1	3-200	DBU17-DM	DBU-EFOD
23	27	3-200	DBU27-DM	DBU-EFOD

2.6

Expulsion Fuses

DBU Type Fuses

Dimensions

Dimensions are in Inches (mm)

2

Non-Loadbreak Mounting

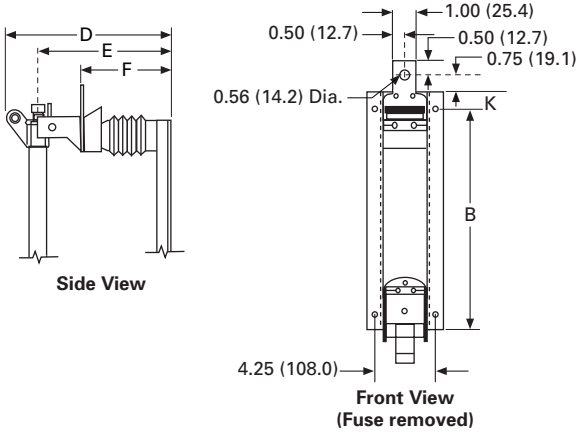

kV Max.	Catalog Number ①	kv BIL	Dimensions				
			B	D	E	F	K
17	DBU17-GNM	95	18.00 (457.2)	16.87 (428.0)	12.12 (307.9)	8.81 (223.8)	2.25 (57.2)
27	DBU27-GNM	125	22.25 (565.2)	19.63 (498.6)	14.87 (377.7)	11.56 (293.6)	2.25 (57.2)
38	DBU38-GNM	150	28.25 (717.6)	21.33 (541.8)	16.58 (421.1)	13.28 (337.3)	2.25 (57.2)

Loadbreak Mounting

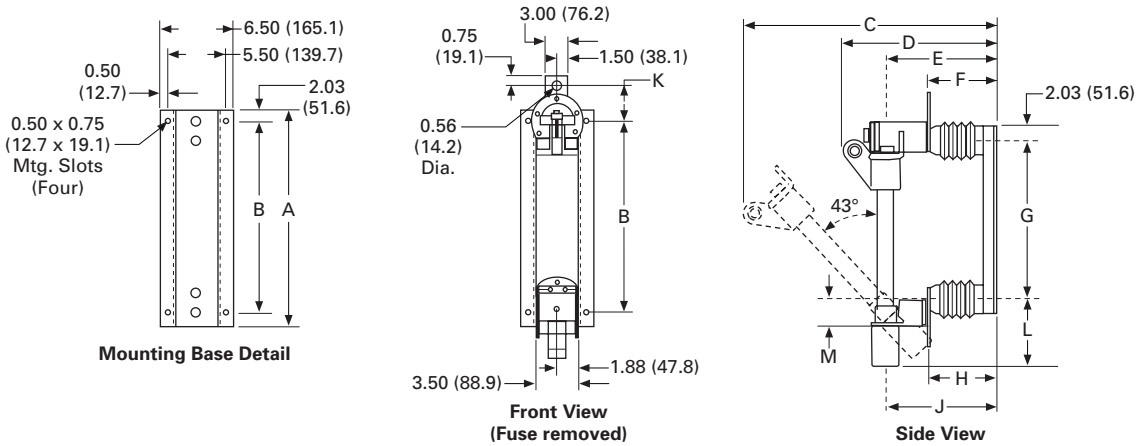

kV Max.	Catalog Number	kv BIL	Dimensions											
			A	B	C	D	E	F	G	H	J	K	L	M
17	DBU17-GDML ①	95	22.50 (571.5)	18.44 (468.4)	30.50 (774.7)	19.25 (489.0)	14.25 (362.0)	9.25 (235.0)	18.44 (468.4)	9.44 (240.0)	11.50 (292.1)	3.0 (76.2)	9.50 (241.3)	3.75 (95.3)
	DBU17-GDMR ②													
27	DBU27-GDML ①	125	26.75 (679.5)	22.69 (576.3)	34.63 (879.6)	21.38 (543.1)	16.75 (425.5)	11.56 (293.6)	22.69 (576.3)	11.75 (298.5)	13.50 (343.0)	3.0 (76.2)	9.50 (241.3)	3.75 (95.3)
	DBU27-GDMR ②													

Notes

- ① Bus for cable termination on right side of mounting.
- ② Bus for cable termination on left side of mounting.

Dimensions are in Inches (mm)

Indoor DBU Fuse Fittings

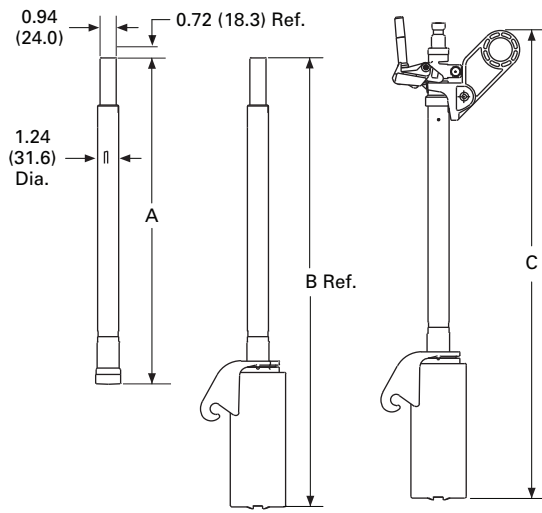

kV Max.	Fuse Unit Fittings		
	A	B	C
17	19.08 (484.6)	27.19 (538.2)	28.82 (732.0)
27	22.58 (573.5)	30.69 (779.5)	32.32 (821.0)
38	28.76 (730.5)	36.87 (936.5)	38.50 (978.0)

Outdoor DBU Fuse Fittings

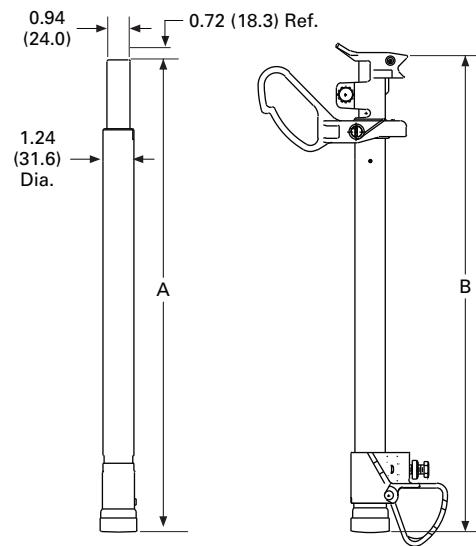

kV Max.	Fuse Unit Fittings	
	A	B
17	19.08 (484.6)	19.41 (493.0)
27	22.58 (573.5)	22.91 (581.9)
38	28.76 (730.5)	28.09 (713.5)

RBA Fuses

2



Contents

<i>Description</i>	<i>Page</i>
RBA/RDB Type Fuses (Including Superseded BA Fuses)	
Installation	V14-T2-52
Applications	V14-T2-53
Operation and Features	V14-T2-53
Catalog Number Selection	V14-T2-58
Interrupting Ratings	V14-T2-59
Product Selection	V14-T2-60
Dimensions	V14-T2-68

RBA/RDB Type Fuses (Including Superseded BA Fuses)

Product Description

BA Fuses

Westinghouse Electric Company introduced the BA range of DE-ION boric acid refillable fuses in the 1930s, and BA refill units have been in continuous use and production since then. Eaton still manufactures BA refill units for use in existing fuse holders and installations. However, the manufacture of most BA fuse holders and all BA mountings has been discontinued.

RBA and RDB Fuses

In 1969, Westinghouse Electric Company introduced the redesigned and improved RBA (indoor with exhaust control device—filter or condenser) and RDB (vented outdoor dropout) ranges of boric acid DE-ION fuses to replace the BA range of fuses

Eaton’s RBA (Refillable Boric Acid) and RDB (Refillable Dropout Boric acid) power fuses are expulsion type power fuses designed for indoor or weatherproof enclosure (RBA) or outdoor vented (RDB) applications. RBA/RDB fuses are renewable (refillable) as the descriptions above state. The whole fuse unit is not discarded after a fault interruption. Usually, only one piece of the fuse, the refill unit, needs to be replaced after an interruption and for this reason, RBA/RDB fuses provide an economical approach to the protection of power circuits rated up to a maximum of 38 kV. They are especially well suited for large industrial load fusing needs.

An RBA/RDB fuse is basically a vented electromechanical device which is applicable to many different power applications. RBA/RDB power fuses are particularly effective for higher operational voltage and higher continuous current applications. RBA/RDB expulsion type fuses do not limit the magnitude of the fault current during operation. They limit the duration of the fault in the electrical system.

RBA/RDB expulsion fuses are available in a wide range of ratings to simplify the selection process. They offer continuous current ratings of 0.5 through 720 amperes, at maximum voltages of 8.3 through 38 kV and with symmetrical interrupting ratings up to 37,500 amperes. RBA and RDB fuses both use replaceable RBA refill units, which are available with both standard speed or time lag characteristics, that when combined with the wide range of ratings, allow maximization of both coordination and protection.

RBA power fuses can be used with either disconnect or non-disconnect mounting, so matching these fuses into the equipment type and layout is a simplified process. Thus RBA fuses are easy to install and maintain. RDB fuses are only available for use in outdoor dropout style mountings.

RBA power fuses have a long and enviable reputation for outstanding protection and reliability, broad selection possibilities, ease of installation and economy over time.

Installation

See Publication No. IL.36-65A-1C for installation instructions.

Applications

In general, an electrical power system consists of three major parts: generation, transmission and distribution. The power distribution area offers an especially significant potential for RBA and RDB power fuse applications. This power distribution system potential could be with the utility, an industrial or commercial user, or the manufacturer of electrical equipment.

Since the RBA/RDB power fuse is refillable (renewable), it is economical for use in a variety of distribution system applications. Primarily, the RBA/RDB is designed for use on:

- Load interrupter switchgear;
- Power transformers;
- High voltage capacitors;
- Pad mounted transformers

RBA fuses can be installed in indoor metalclad or metal enclosed load interrupter switchgear, or fuse cabinets for both indoor and outdoor use. RDB fuses are intended for outdoor use, but protecting the same types of loads as RBA fuses.

A common application for RBA power fuses is in the primary circuit of a power transformer. In this application, fuses must isolate the transformer circuit from the upstream supply when a fault occurs in or beyond the transformer, but must not operate on transformer inrush.

RBA fuses can also be used to protect capacitor banks. Capacitors require protection from fault currents which could cause a capacitor to rupture.

Selection of the fuse type is dependent on many factors, including: user or supplier preference, cost and system coordination. If the required voltage and continuous current ratings are high and downstream coordination is critical, RBA power fuses can provide very effective protection. See **Page V14-T2-20** for more information on expulsion fuse application.

Operation and Features

A renewable (refillable) boric acid expulsion type fuse comprises the following major components:

- A replaceable refill unit, comprising the current responsive element and the arc de-ionizing and extinguishing boric acid sold filler material, all contained within a high strength glass epoxy tube and with end connections for interfacing with the fuse holder. This is the part of the fuse which is discarded after a fuse interruption
- A reusable fuse holder. The fuse holder comprises a high strength glass epoxy tube and cast high conductivity end connections to interface the fuse holder with the internal refill unit and the external fuse mounting. The fuse holder assembly also includes the spring and shunt assembly which is pre-loaded when a fuse holder is charged with a refill unit
- For indoor applications only (RBA fuses only), a reusable exhaust control device, (condenser, discharge filter, or high capacity discharge filter) which de-ionizes and absorbs all or part of the "expulsion exhaust" from the fuse during operation
- A reusable mounting to interface the loaded fuse holder assembly into the protected circuit. The mounting comprises the live parts, a pair of assemblies that interface with and securely support the fuse holder, and provide suitable connection points for the external circuit. Below the live parts are insulators, appropriate for the system insulation rating, which are mounted on a rigid metal support to prevent flexing of the mounting during fuse or associated switch operation

Mountings are available in disconnect and non-disconnect configurations for RBA fuses and a dropout configuration for RDB fuses.

A non-disconnect mounting permanently mounts the fuse holder containing the refill with tension type fuse clips or bolted connections until it is completely removed.

The disconnect mounting permits a fuse to be opened, closed, or even lifted out of the mounting once it is opened. An insulated stick with a hook on the end of it is used to perform the opening and closing functions in a disconnect mounting. The insulated stick is referred to as a switch stick.

Depending on the point of application, it is often necessary to attach a discharge suppressor (filter, condenser or muffler) to the fuse unit. This metallic device acts to retard, to varying degrees, the gases and noise associated with an expulsion type fuse.

When the fuse element melts inside the refill, an arc is initiated and elongated. The heat of the arc decomposes the boric acid producing water vapor and boric anhydride. These two by-products extinguish the arc by blasting through it and exit from the bottom of the fuse. The gases are usually assisted with the interruption process by a spring loaded mechanical device located inside the fuse holder. In addition to the exhaust produced during interruption, a significant amount of noise also results. At this point, the previously mentioned suppressor is often used to limit this discharge and noise. The type of suppressor installed depends upon the requirements at the point of application.

RBA and RDB Details

Eaton's renewable RBA or RDB fuse unit is not totally discarded after it interrupts a fault. This makes the RBA quite economical to use over time. Normally, only the fuse refill is discarded with the RBA design.

The RBA power fuse provides performance characteristics especially intended for power system protection up to an operational voltage of 34.5 kV. Because RBA fuses are available in a wide range of continuous current ratings and time-current characteristics, close fusing can be achieved, maximizing the protection and overall coordination. The quality and accuracy of the RBA design and manufacturing process ensures accurate initial and ongoing melting time-current characteristics. Proven RBA power fuses perform as intended and operate exactly when and how they should, and do not operate when they should not operate. This is a subtle but important point.

Each individual RBA fuse component is discussed individually. Its makeup and unique role in the protection process are also discussed.

RBA Refill Unit

The internal parts of an RBA refill unit are a calibrated current responsive fuse element and a parallel high strength strain element, an arcing rod, an auxiliary arcing rod assembly, and a solid boric acid liner which assists with the interruption. The lower end of the fuse element is attached to an end cap which is securely crimped onto the lower end of a glass-epoxy refill tube and the upper end is brazed or securely crimped to the main arcing rod. The upper end of the tube permits the upper end of the arcing rod to exit the refill tube through a molded plug. At the upper end of the refill unit, the plug is sealed around the arcing rod where it exits from the refill tube. The lower end of the refill unit is sealed with a blowout disc to maintain the integrity of the seal in RDB outdoor applications. The seal must be removed before an exhaust control device is fitted to a fuse holder for indoor applications, to prevent clogging the exhaust control device.

The calibrated fuse element assembly determines the operational time-current characteristics of the RBA fuse. It is sensitive to the heat produced by the amount of current flowing. How, when or if it melts for different magnitudes of current and amounts of time, a particular current magnitude experienced by the fuse is indicated on the specific

time-current characteristic curve for a particular fuse. RBA fuse elements are available in standard and time-lag configurations. The standard element assemblies are made of pure silver with a parallel Nichrome strain wire, and the time-lag elements have a calibrated tin alloy joint. The Nichrome wire relieves the fuse element of any strain put on it by the spring loaded arcing rod. This parallel high resistance vaporizes immediately after the fuse element melts.

The heavy copper cylindrical arcing rod is contained within the main bore of the boric acid liner and performs two functions. Under normal operating conditions, it carries the continuous rated current of the fuse. When the fuse element melts during a fault interruption, the arcing rod lengthens the arc as it is pulled through the boric acid liner. This backward movement occurs because the arcing rod is under spring tension from the outside of the refill.

An auxiliary arcing rod is contained within the small bore of the boric acid liner. It plays a role in the proper operation of the fuse under low intensity fault conditions. No load current is carried by the auxiliary wire.

RBA Refill Unit Operation

Under fault conditions, the fuse and strain elements melt and the arcing rods pull the arc back through the boric acid liner. Intense heat from the arc separates the hydrated boric acid, producing water vapor and inert boric anhydride. This expanding mixture extinguishes the arc by blasting through and de-ionizing it. The exhaust caused by the interruption exits from the bottom of the fuse. The de-ionizing action prevents the arc from re-striking after a current zero.

RBA fuses are designed to interrupt short-circuit currents within 1/2 cycle at the next current zero. Two different chambers in parallel within the solid boric acid liner provide for selective operation and interruption for both low current and high current faults using the principles of de-ionization.

Low Current Fault Interruption

When a low current fault occurs, the main fuse and strain elements melt and the main and auxiliary arcing rods start to draw through the boric acid liner. At this stage, the main rod circuit is open, shorted out by the auxiliary rod. The fine auxiliary coil rapidly melts and the arc is extinguished in the small bore of the boric acid liner. The arcing rod drawing no arc, moves back to an open position because of the spring tension.

High Current Fault Operation

A high fault current melts the main fuse and strain element and transfers to the auxiliary fuse wire. In the small bore, the high arc current creates a high voltage causing the arcing rod in the main bore to restrike. The arcing rod then draws the arc through the main bore where it is quickly extinguished.

RBA Refill Unit Ratings

RBA fuse refills are ANSI/IEEE "E" rated. The "E" rating defines a current response that is intended to produce a degree of electrical interchangeability among fuse manufacturers. A 100E fuse carries 100 amperes or below continuously and will melt in a defined amount of time for a defined range of current above the fuse's continuous current magnitude. This performance will be the same for all fuses with an E designation.

RBA Fuse Holder

An RBA fuse holder has a glass epoxy tube which encloses and supports the fuse refill unit. Also inside the tube is a spring and shunt assembly, which makes an electrical connection to the top end of the refill unit. At the ends, the fuse holder has high conductivity copper alloy ferrules, which include the required features to interface with a non-disconnect, or disconnect mounting. The holder delivers excellent dielectric strength as well as mechanical strength for support purposes. The RBA holder is not suitable for outdoor applications.

RDB Fuse Holder

An RDB fuse holder has a glass epoxy tube which is coated with a protective gray colored UV resistant coating for outdoor application. This tube encloses and supports the fuse refill unit. Also inside the tube is a spring and shunt assembly which makes an electrical connection to the top end of the refill unit. The RDB spring and shunt assembly incorporates a ballistic trip pin to unlatch the fuse holder when the fuse operates, initiating the dropout action. At the ends, the fuse holder has high conductivity silver plated copper alloy ferrules, which include the required features to interface with a dropout mounting. The holder delivers excellent dielectric strength as well as mechanical strength for support purposes. The RDB holder is designed for outdoor applications with the UV protected tube and silver plated terminals.

After an RBA or RDB fuse unit performs its function by interrupting a fault, the fuse holder is removed from its mounting, opened and only the fuse refill unit is replaced. The fuse unit can then be once again put back into operation.

Spring and Shunt Assembly

A spring and shunt assembly comprises a stainless steel helical spring that encloses a tangle free flexible braided high conductivity copper shunt, which prevents the spring from conducting load or fault current. This assembly attaches on the lower end to the threaded end of the refill unit, and at the top end to the top contact of the fuse holder. With the spring and shunt assembly properly attached to and enclosed in the holder, the refill arcing rod assembly is put under spring tension, ready to move the rod through the boric acid liner.

Holder Contacts and Hardware

The high conductivity cast copper alloy upper and lower contacts of the fuse holder make low resistance electrical connections between the fuse refill and the mounting. These contacts also function to dissipate heat in normal service.

The difference between non-disconnect and disconnect or dropout type fuse holders is the design of the top and bottom contacts of the fuse holder. Disconnect or dropout electrical contacts permit the fuse to be switch stick operated in a compatible disconnect or dropout type mounting. A hookeye is provided at the lower contact of the fuse holder to allow the fuse holder to be lifted into the hinge end of the mounting, and at the upper contact to allow the fuse holder to be swung to open or close the fuse. A non-disconnect contact requires the fuse unit to be supported in a permanent position until completely assembled into or removed from a compatible mounting.

RBA and RDB Mountings

Both non-disconnect and disconnect mountings are available for RBA power fuses. Dropout mountings are used with RDB fuse units. Mountings provide everything necessary to safely install a compatible RBA fuse unit into the protected circuit. The rigid mounting base is a metal support to which the porcelain or glass polyester insulators are attached. They insulate the live parts and the installed fuse unit from the mounting base and everything beyond the base.

Live parts are available without the insulators or mounting base because some applications have unique mounting situations or the customer may choose to add additional value by supplying the insulators and base. It is still necessary to mount the live parts and insulators to a rigid support structure to prevent the fuse from unlatching due to mechanical disturbances. It is the responsibility of the customer to make sure that all mounting requirements are met when using just the live parts.

RBA non-disconnect mountings can be supplied in one of two configurations. RBA-200 and RBA-400 mountings use upper and lower fuse clamps to hold the fuse unit in position. The clamps securely locate each end of the fuse holder into the mounting. RBA-800 mountings hold the fuse unit in place by solidly bolting it into position. The type of non-disconnect mounting to be used depends on the size and configuration of the fuse unit.

RBA disconnect and RDB dropout mountings are switch stick-operable, facilitating opening, closing, and fuse replacement. The switch stick can be used to open and close the fuse, and also to lift the fuse into and out of the mounting. This keeps the operator well clear of any live parts during fuse removal. The lower end of the mounting is the hinged end and the upper end is the latched end and they work in conjunction with the compatible contacts of the fuse holder. Positive electrical connections are maintained at both ends of the mounting through the spring fingers at the lower end and clip type contacts on the upper end. The spring fingers are compressed on closing in of the fuse holder.

RBA Exhaust Control Devices

For indoor applications, phase-to-phase clearances and clearances to ground are generally restricted, and exhaust control devices must be used with RBA indoor expulsion fuses to retard the gases and reduce the noise associated with this type of fuse operation. Eaton offers three devices called the condenser, the discharge filter and the high capacity discharge filter—the high capacity discharge filter has limited application at a specific voltage level. Other manufacturers refer to such devices as suppressors or silencers.

The exhaust control device is threaded onto the bottom of an RBA fuse holder to minimize the noise and exhaust while containing the arc within the fuse during interruption, and also to clamp the lower end of the fuse refill unit into the fuse holder to ensure an adequately tight electrical and mechanical connection to minimize contact resistance and enable thermal conduction out of the refill unit. Exhaust control devices are metallic containers with copper screen inside to absorb and dissipate arc heat and condense steam to water. Although the inner and outer metals of the condenser and discharge filter are similar, the internal designs and venting methods are different. A condenser can be identified by the very restrictive bottom plate with only one small hole to allow the slow release, after interruption, of water absorbed by the condenser during a fuse interruption. A discharge filter is very less restrictive, and acts only to de-ionize the exhaust gases and reduce the flow rate of the discharge. The flow restriction in a condenser causes a back-pressure in the fuse which reduces the ability of the fuse to interrupt higher current faults.

RBA/RDB Interruption and Protection

The operation of RBA and RDB fuses must be considered for three sets of conditions:

- **Normal loading**—This is when the circuit current is below the allowable continuous current or within the limits of the allowable short-time overload current shown on **Page V14-T2-8** of the Expulsion Fuse Introduction, for the particular set of application conditions. Under such normal loading, the fuse is not subject to any conditions that would degrade its long term integrity, or affect its ability to correctly interrupt fault conditions.

Note: If the current is at or below the allowable continuous current for the particular set of conditions, that is, allowing for an elevated ambient temperature, high altitude, or an enclosure that restricts natural cooling, the temperature rise and maximum temperature of the fuse will be below the allowable limits stated in IEEE Std. C37.40™-2003.

Note: If temporary overloads are below the temporary overload curve, with values based on the allowable continuous current, not on the rated continuous current, the fuse unit or refill unit, although it may be subject to temporarily slightly elevated temperatures, will not be subject to conditions that could affect its long term integrity or degrade its ability to correctly interrupt fault conditions.

Note: After the fuse has been subjected to a temporary overload as indicated on **Page V14-T2-8**, the current should be reduced to no more than the normal circuit full load condition—typically (fuse rated continuous current) /1.4 for a period long enough for any temporary excess heat to be dissipated—typically 2 hours minimum.

- **Overloading**—This occurs if the circuit current exceeds the allowable short-time overload conditions shown on **Page V14-T2-8** of the Expulsion Fuse Introduction, but is below 240% (for fuses rated 100E or below) or 264% (for fuses rated above 100E).

If the fuse is exposed to these overload conditions, the long term integrity of the fuse refill unit can be degraded and its ability to correctly interrupt fault conditions may be seriously compromised.

Note: With a fuse unit or fuse refill unit rated 100E or less, the element may melt at any current between 200% and 240% of the E rating, and with a fuse unit or refill unit rated more than 100E, the element may melt at any current between 220% and 264% of the E rating. These 10% ranges allow for variations between fuses because of manufacturing tolerances, and so on, on the fuse assembly. The minimum melting current of the fuse could be anywhere in the range between the value on the minimum-melting time-current characteristic and the value on the total-clearing time-current characteristic. At this end of the curve, the total-clearing and maximum-melting characteristics are effectively the same. The maximum values of the range are quoted here because this is the lower limit of the current at which it is known that the fuse element will melt.

- **Faults**—This covers all conditions from about 240% for a fuse rating of 100E or less, or 264% for a fuse rating greater than 100E up to the interrupting rating of the fuse. The fuse will interrupt the fault current in a time indicated by the published fuse time-current characteristic curves. Interruption occurs at a natural current zero of the fault current, when the dielectric strength of the fuse withstands the combination of power frequency recovery voltage and transient recovery voltage.

The noise of the operation and the quantity of exhaust products is reduced in indoor RBA applications by the use of an exhaust control device which partially absorbs and de-ionizes the exhaust gases. In outdoor applications, RDB fuses are exhausted to atmosphere.

The **rated maximum voltage** of RBA or RDB power fuse is the highest power frequency system voltage at which the fuse is designed to operate. The dielectric withstand level corresponds to insulation levels of power class equipment. Rated maximum voltage levels for RBA power fuses are: 8.3, 15.5, 25.5 and 38.0 kV.

Fuses, including RBA/RDB power fuses, should never be applied where the available fault current at the fuse location exceeds the rated maximum interrupting current of the fuse. The rated maximum interrupting current of an RBA fuse is the rms value of the symmetrical component (AC component) of the highest current which the RBA is has been demonstrated to be able to successfully interrupt under any condition of asymmetry. RBA interrupting ratings are shown in the table on **Page V14-T2-59**. The rated continuous current of an RBA or RDB power fuse should at least equal or preferably exceed the maximum load current where the fuse is applied. Fuses are designed to carry their rated continuous current without exceeding the temperature rise outlined in IEEE standards. RBA and RDB fuses are available with continuous current ratings up to 720 amperes current ratings and carry an "E" designation.

2.7

Expulsion Fuses

RBA/RDB Type Fuses (Including Superseded BA Fuses)

Catalog Number Selection

2

RBA and RBT Fuse Units

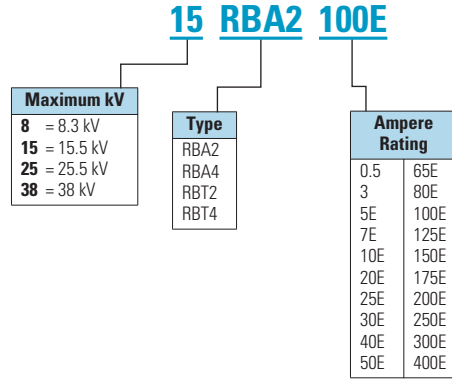

RBA and RBT Fuse Holders, Mounting and Accessories

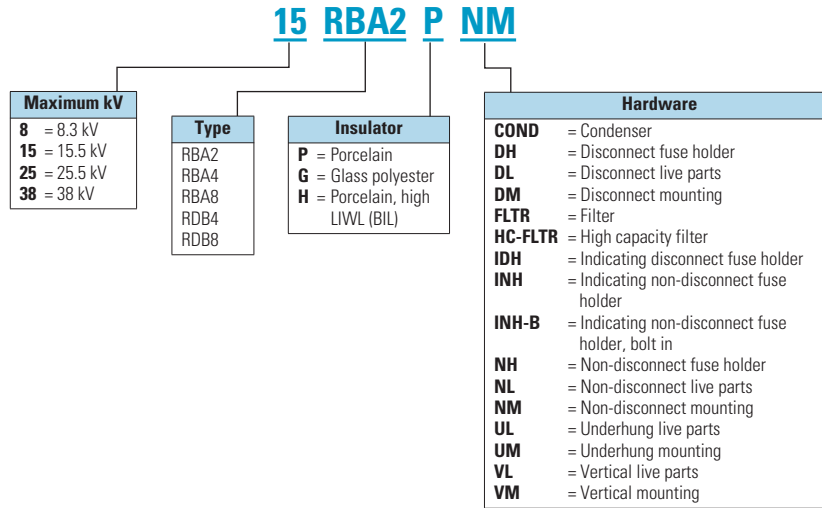

Interrupting Ratings

RBA and RBT Fuse Interrupting Ratings

Fuse Nominal Rated Voltage Rating kV	Maximum System Voltage kV	RDB2 Outdoor Vented rms Symmetrical kA	RBA2 Indoor with Filter rms Symmetrical kA	RDB2 Indoor with Condenser rms Symmetrical kA
2.4	2.75	19.0	19.0	10.0
4.16	4.8	19.0	19.0	10.0
4.8	5.5	19.0	19.0	10.0
7.2	8.3	16.6	16.6	10.0
13.8	14.4	14.4	14.4	8.0
14.4	15.5	14.4	14.4	8.0
23	25.5	10.5	10.5	6.3
34.5	38	6.9	6.9	5.0

RBA and RBT Fuse Interrupting Ratings, continued

Fuse Nominal Rated Voltage Rating kV	Maximum System Voltage kV	RDB4/8 Outdoor Vented rms Symmetrical kA	RBA4/8 Indoor with Filter rms Symmetrical kA	RDA4/4 Indoor with Condenser rms Symmetrical kA	RBA4/8 Indoor with High Capacity Filter rms Symmetrical kA
2.4	2.75	37.7	37.7	20.0	—
4.16	4.8	37.5	37.5	20.0	—
4.8	5.5	37.5	37.5	20.0	—
7.2	8.3	29.4	29.4	16.0	—
13.8	14.4	29.4	29.4	12.5	36.0
14.4	15.5	29.4	29.4	12.5	—
23	25.5	21.0	21.0	10.0	—
34.5	38	16.8	16.8	10.0	—

Product Selection

2

8RBA2 and 8RBA4 Type Standard Speed and 8RBT2 and 8RBT4 Time Lag Fuse Refill Units

Voltage (kV)			Standard Speed			Time Lag			Performance Curves	
Nominal	Maximum	Ampere Rating	Catalog Number	Catalog Number	Approximate Shipping Weight Lbs (kg)	Minimum Melting	Total Clearing	Minimum Melting	Total Clearing	
7.2	8.3	10E	8RBA2-10E	—	1.0 (0.5)	TC62882301	TC66701401	—	—	
7.2	8.3	15E	8RBA2-15E	—	1.0 (0.5)	TC62882301	TC66701401	—	—	
7.2	8.3	20E	8RBA2-20E	8RBT2-20E	1.0 (0.5)	TC62882301	TC66701401	TC62886301	TC66701301	
7.2	8.3	25E	8RBA2-25E	8RBT2-25E	1.0 (0.5)	TC62882301	TC66701401	TC62886301	TC66701301	
7.2	8.3	30E	8RBA2-30E	8RBT2-30E	1.0 (0.5)	TC62882301	TC66701401	TC62886301	TC66701301	
7.2	8.3	40E	8RBA2-40E	8RBT2-40E	1.0 (0.5)	TC62882301	TC66701401	TC62886301	TC66701301	
7.2	8.3	50E	8RBA2-50E	8RBT2-50E	1.0 (0.5)	TC62882301	TC66701401	TC62886301	TC66701301	
7.2	8.3	65E	8RBA2-65E	8RBT2-65E	1.0 (0.5)	TC62882301	TC66701401	TC62886301	TC66701301	
7.2	8.3	80E	8RBA2-80E	8RBT2-80E	1.0 (0.5)	TC62882301	TC66701401	TC62886301	TC66701301	
7.2	8.3	100E	8RBA2-100E	8RBT2-100E	1.0 (0.5)	TC62882301	TC66701401	TC62886301	TC66701301	
7.2	8.3	125E	8RBA2-125E	8RBT2-125E	1.0 (0.5)	TC62882301	TC66701401	TC62886301	TC66701301	
7.2	8.3	150E	8RBA2-150E	8RBT2-150E	1.0 (0.5)	TC62882301	TC66701401	TC62886301	TC66701301	
7.2	8.3	175E	8RBA2-175E	—	1.0 (0.5)	TC62882301	TC66701401	—	—	
7.2	8.3	200E	8RBA2-200E	8RBT2-200E	1.0 (0.5)	TC62882301	TC66701401	TC62886301	TC66701301	
7.2	8.3	0.5	8RBA4-.5	—	2.1 (1.0)	TC62886101	TC66701501	—	—	
7.2	8.3	3	8RBA4-3	—	2.1 (1.0)	TC62886101	TC66701501	—	—	
7.2	8.3	5E	8RBA4-5E	—	2.1 (1.0)	TC62886101	TC66701501	—	—	
7.2	8.3	7E	8RBA4-7E	—	2.1 (1.0)	TC62886101	TC66701501	—	—	
7.2	8.3	10E	8RBA4-10E	—	2.1 (1.0)	TC62886101	TC66701501	—	—	
7.2	8.3	15E	8RBA4-15E	—	2.1 (1.0)	TC62886101	TC66701501	—	—	
7.2	8.3	20E	8RBA4-20E	8RBT4-20E	2.1 (1.0)	TC62886101	TC66701501	TC62886501	TC66701201	
7.2	8.3	25E	8RBA4-25E	8RBT4-25E	2.1 (1.0)	TC62886101	TC66701501	TC62886501	TC66701201	
7.2	8.3	30E	8RBA4-30E	8RBT4-30E	2.1 (1.0)	TC62886101	TC66701501	TC62886501	TC66701201	
7.2	8.3	40E	8RBA4-40E	8RBT4-40E	2.1 (1.0)	TC62886101	TC66701501	TC62886501	TC66701201	
7.2	8.3	50E	8RBA4-50E	8RBT4-50E	2.1 (1.0)	TC62886101	TC66701501	TC62886501	TC66701201	
7.2	8.3	65E	8RBA4-65E	8RBT4-65E	2.1 (1.0)	TC62886101	TC66701501	TC62886501	TC66701201	
7.2	8.3	70E	8RBA4-80E	8RBT4-80E	2.1 (1.0)	TC62886101	TC66701501	TC62886501	TC66701201	
7.2	8.3	100E	8RBA4-100E	8RBT4-100E	2.1 (1.0)	TC62886101	TC66701501	TC62886501	TC66701201	
7.2	8.3	125E	8RBA4-125E	8RBT4-125E	2.1 (1.0)	TC62886101	TC66701501	TC62886501	TC66701201	
7.2	8.3	150E	8RBA4-150E	8RBT4-150E	2.1 (1.0)	TC62886101	TC66701501	TC62886501	TC66701201	
7.2	8.3	175E	8RBA4-175E	—	2.1 (1.0)	TC62886101	TC66701501	—	—	
7.2	8.3	200E	8RBA4-200E	8RBT4-200E	2.1 (1.0)	TC62886101	TC66701501	TC62886501	TC66701201	
7.2	8.3	250E	8RBA4-250E	8RBT4-250E	2.1 (1.0)	TC62886101	TC66701501	TC63943501	TC66701101	
7.2	8.3	300E	8RBA4-300E	8RBT4-300E	2.1 (1.0)	TC62886101	TC66701501	TC63943501	TC66701101	
7.2	8.3	400E	8RBA4-400E	8RBT4-400E	2.1 (1.0)	TC62886101	TC66701501	TC63943501	TC66701101	
7.2	8.3	450E	(2) 8RBA4-250E	(2) 8RBT2-250E	—	TC62886102	TC66701001	TC63943502	TC66700901	
7.2	8.3	540E	(2) 8RBA4-300E	(2) 8RBT2-300E	—	TC62886102	TC66701001	TC63943502	TC66700901	
7.2	8.3	720E	(2) 8RBA4-400E	(2) 8RBT2-400E	—	TC62886102	TC66701001	TC63943502	TC66700901	

15RBA2 and 15RBA4 Type Standard Speed and 15RBT2 and 15RBT4 Time Lag Fuse Refill Units

Voltage (kV)		Ampere Rating	Standard Speed		Approximate Shipping Weight Lbs (kg)	Performance Curves			
Nominal	Maximum		Catalog Number	Time Lag Catalog Number		Standard Speed Minimum Melting	Total Clearing	Time Lag Minimum Melting	Total Clearing
14	16	10E	15RBA2-10E	—	1.1 (0.5)	TC62882301	TC66701401	—	—
14	16	15E	15RBA2-15E	—	1.1 (0.5)	TC62882301	TC66701401	—	—
14	16	20E	15RBA2-20E	15RBT2-20E	1.1 (0.5)	TC62882301	TC66701401	TC62886301	TC66701301
14	16	25E	15RBA2-25E	15RBT2-25E	1.1 (0.5)	TC62882301	TC66701401	TC62886301	TC66701301
14	16	30E	15RBA2-30E	15RBT2-30E	1.1 (0.5)	TC62882301	TC66701401	TC62886301	TC66701301
14	16	40E	15RBA2-40E	15RBT2-40E	1.1 (0.5)	TC62882301	TC66701401	TC62886301	TC66701301
14	16	50E	15RBA2-50E	15RBT2-50E	1.1 (0.5)	TC62882301	TC66701401	TC62886301	TC66701301
14	16	65E	15RBA2-65E	15RBT2-65E	1.1 (0.5)	TC62882301	TC66701401	TC62886301	TC66701301
14	16	80E	15RBA2-80E	15RBT2-80E	1.1 (0.5)	TC62882301	TC66701401	TC62886301	TC66701301
14	16	100E	15RBA2-100E	15RBT2-100E	1.1 (0.5)	TC62882301	TC66701401	TC62886301	TC66701301
14	16	125E	15RBA2-125E	15RBT2-125E	1.1 (0.5)	TC62882301	TC66701401	TC62886301	TC66701301
14	16	150E	15RBA2-150E	15RBT2-150E	1.1 (0.5)	TC62882301	TC66701401	TC62886301	TC66701301
14	16	175E	15RBA2-175E	—	1.1 (0.5)	TC62882301	TC66701401	—	—
14	16	200E	15RBA2-200E	15RBT2-200E	1.1 (0.5)	TC62882301	TC66701401	TC62886301	TC66701301
14	16	0.5	15RBA4-.5	—	2.3 (1.05)	TC62886101	TC66701501	—	—
14	16	3	15RBA4-3	—	2.3 (1.05)	TC62886101	TC66701501	—	—
14	16	5E	15RBA4-5E	—	2.3 (1.05)	TC62886101	TC66701501	—	—
14	16	7E	15RBA4-7E	—	2.3 (1.05)	TC62886101	TC66701501	—	—
14	16	10E	15RBA4-10E	—	2.3 (1.05)	TC62886101	TC66701501	—	—
14	16	15E	15RBA4-15E	—	2.3 (1.05)	TC62886101	TC66701501	—	—
14	16	20E	15RBA4-20E	15RBT4-20E	2.3 (1.05)	TC62886101	TC66701501	TC62886501	TC66701201
14	16	25E	15RBA4-25E	15RBT4-25E	2.3 (1.05)	TC62886101	TC66701501	TC62886501	TC66701201
14	16	30E	15RBA4-30E	15RBT4-30E	2.3 (1.05)	TC62886101	TC66701501	TC62886501	TC66701201
14	16	40E	15RBA4-40E	15RBT4-40E	2.3 (1.05)	TC62886101	TC66701501	TC62886501	TC66701201
14	16	50E	15RBA4-50E	15RBT4-50E	2.3 (1.05)	TC62886101	TC66701501	TC62886501	TC66701201
14	16	65E	15RBA4-65E	15RBT4-65E	2.3 (1.05)	TC62886101	TC66701501	TC62886501	TC66701201
14	16	70E	15RBA4-80E	15RBT4-80E	2.3 (1.05)	TC62886101	TC66701501	TC62886501	TC66701201
14	16	100E	15RBA4-100E	15RBT4-100E	2.3 (1.05)	TC62886101	TC66701501	TC62886501	TC66701201
14	16	125E	15RBA4-125E	15RBT4-125E	2.3 (1.05)	TC62886101	TC66701501	TC62886501	TC66701201
14	16	150E	15RBA4-150E	15RBT4-150E	2.3 (1.05)	TC62886101	TC66701501	TC62886501	TC66701201
14	16	175E	15RBA4-175E	—	2.3 (1.05)	TC62886101	TC66701501	—	—
14	16	200E	15RBA4-200E	15RBT4-200E	2.3 (1.05)	TC62886101	TC66701501	TC62886501	TC66701201
14	16	250E	15RBA4-250E	15RBT4-250E	2.3 (1.05)	TC62886101	TC66701501	TC63943501	TC66701101
14	16	300E	15RBA4-300E	15RBT4-300E	2.3 (1.05)	TC62886101	TC66701501	TC63943501	TC66701101
14	16	400E	15RBA4-400E	15RBT4-400E	2.3 (1.05)	TC62886101	TC66701501	TC63943501	TC66701101
14	16	450E	(2) 15RBA4-250E	(2) 15RBT2-250E	—	TC62886102	TC66701001	TC63943502	TC66700901
14	16	540E	(2) 15RBA4-300E	(2) 15RBT2-300E	—	TC62886102	TC66701001	TC63943502	TC66700901
14	16	720E	(2) 15RBA4-400E	(2) 15RBT2-400E	—	TC62886102	TC66701001	TC63943502	TC66700901

25RBA2 and 25RBA4 Type Standard Speed and 25RBT2 and 25RBT4 Time Lag Fuse Refill Units

Voltage (kV)		Ampere Rating	Standard Speed		Approximate Shipping Weight Lbs (kg)	Performance Curves			
Nominal	Maximum		Catalog Number	Time Lag Catalog Number		Standard Speed Minimum Melting	Total Clearing	Time Lag Minimum Melting	Total Clearing
23	26	10E	25RBA2-10E	—	1.3 (0.6)	TC62882301	TC66701401	—	—
23	26	15E	25RBA2-15E	—	1.3 (0.6)	TC62882301	TC66701401	—	—
23	26	20E	25RBA2-20E	25RBT2-20E	1.3 (0.6)	TC62882301	TC66701401	TC62886301	TC66701301
23	26	25E	25RBA2-25E	25RBT2-25E	1.3 (0.6)	TC62882301	TC66701401	TC62886301	TC66701301
23	26	30E	25RBA2-30E	25RBT2-30E	1.3 (0.6)	TC62882301	TC66701401	TC62886301	TC66701301
23	26	40E	25RBA2-40E	25RBT2-40E	1.3 (0.6)	TC62882301	TC66701401	TC62886301	TC66701301
23	26	50E	25RBA2-50E	25RBT2-50E	1.3 (0.6)	TC62882301	TC66701401	TC62886301	TC66701301
23	26	65E	25RBA2-65E	25RBT2-65E	1.3 (0.6)	TC62882301	TC66701401	TC62886301	TC66701301
23	26	80E	25RBA2-80E	25RBT2-80E	1.3 (0.6)	TC62882301	TC66701401	TC62886301	TC66701301
23	26	100E	25RBA2-100E	25RBT2-100E	1.3 (0.6)	TC62882301	TC66701401	TC62886301	TC66701301
23	26	125E	25RBA2-125E	25RBT2-125E	1.3 (0.6)	TC62882301	TC66701401	TC62886301	TC66701301
23	26	150E	25RBA2-150E	25RBT2-150E	1.3 (0.6)	TC62882301	TC66701401	TC62886301	TC66701301
23	26	175E	25RBA2-175E	—	1.3 (0.6)	TC62882301	TC66701401	—	—
23	26	200E	25RBA2-200E	25RBT2-200E	1.3 (0.6)	TC62882301	TC66701401	TC62886301	TC66701301
23	26	0.5	25RBA4-5	—	2.7 (1.25)	TC62886101	TC66701501	—	—
23	26	3	25RBA4-3	—	2.7 (1.25)	TC62886101	TC66701501	—	—
23	26	5E	25RBA4-5E	—	2.7 (1.25)	TC62886101	TC66701501	—	—
23	26	7E	25RBA4-7E	—	2.7 (1.25)	TC62886101	TC66701501	—	—
23	26	10E	25RBA4-10E	—	2.7 (1.25)	TC62886101	TC66701501	—	—
23	26	15E	25RBA4-15E	—	2.7 (1.25)	TC62886101	TC66701501	—	—
23	26	20E	25RBA4-20E	25RBT4-20E	2.7 (1.25)	TC62886101	TC66701501	TC62886501	TC66701201
23	26	25E	25RBA4-25E	25RBT4-25E	2.7 (1.25)	TC62886101	TC66701501	TC62886501	TC66701201
23	26	30E	25RBA4-30E	25RBT4-30E	2.7 (1.25)	TC62886101	TC66701501	TC62886501	TC66701201
23	26	40E	25RBA4-40E	25RBT4-40E	2.7 (1.25)	TC62886101	TC66701501	TC62886501	TC66701201
23	26	50E	25RBA4-50E	25RBT4-50E	2.7 (1.25)	TC62886101	TC66701501	TC62886501	TC66701201
23	26	65E	25RBA4-65E	25RBT4-65E	2.7 (1.25)	TC62886101	TC66701501	TC62886501	TC66701201
23	26	70E	25RBA4-80E	25RBT4-80E	2.7 (1.25)	TC62886101	TC66701501	TC62886501	TC66701201
23	26	100E	25RBA4-100E	25RBT4-100E	2.7 (1.25)	TC62886101	TC66701501	TC62886501	TC66701201
23	26	125E	25RBA4-125E	25RBT4-125E	2.7 (1.25)	TC62886101	TC66701501	TC62886501	TC66701201
23	26	150E	25RBA4-150E	25RBT4-150E	2.7 (1.25)	TC62886101	TC66701501	TC62886501	TC66701201
23	26	175E	25RBA4-175E	—	2.7 (1.25)	TC62886101	TC66701501	—	—
23	26	200E	25RBA4-200E	25RBT4-200E	2.7 (1.25)	TC62886101	TC66701501	TC62886501	TC66701201
23	26	250E	25RBA4-250E	25RBT4-250E	2.7 (1.25)	TC62886101	TC66701501	TC63943501	TC66701101
23	26	300E	25RBA4-300E	25RBT4-300E	2.7 (1.25)	TC62886101	TC66701501	TC63943501	TC66701101
23	26	450E	(2) 25RBA4-250E	(2) 25RBT2-250E	2.7 (1.25)	TC62886102	TC66701001	TC63943502	TC66700901
23	26	540E	(2) 25RBA4-300E	(2) 25RBT2-300E	—	TC62886102	TC66701001	TC63943502	TC66700901

38RBA4 and 38RBA4 Type Standard Speed and 38RBT2 and 238RBT4 Time Lag Fuse Refill Units

Voltage (kV)		Ampere Rating	Standard Speed		Approximate Shipping Weight Lbs (kg)	Performance Curves			
Nominal	Maximum		Catalog Number	Time Lag Catalog Number		Standard Speed Minimum Melting	Total Clearing	Time Lag Minimum Melting	Total Clearing
35	38	10E	38RBA2-10E	—	1.4 (0.65)	TC62882301	TC66701401	—	—
35	38	15E	38RBA2-15E	—	1.4 (0.65)	TC62882301	TC66701401	—	—
35	38	20E	38RBA2-20E	38RBT2-20E	1.4 (0.65)	TC62882301	TC66701401	TC62886301	TC66701301
35	38	25E	38RBA2-25E	38RBT2-25E	1.4 (0.65)	TC62882301	TC66701401	TC62886301	TC66701301
35	38	30E	38RBA2-30E	38RBT2-30E	1.4 (0.65)	TC62882301	TC66701401	TC62886301	TC66701301
35	38	40E	38RBA2-40E	38RBT2-40E	1.4 (0.65)	TC62882301	TC66701401	TC62886301	TC66701301
35	38	50E	38RBA2-50E	38RBT2-50E	1.4 (0.65)	TC62882301	TC66701401	TC62886301	TC66701301
35	38	65E	38RBA2-65E	38RBT2-65E	1.4 (0.65)	TC62882301	TC66701401	TC62886301	TC66701301
35	38	80E	38RBA2-80E	38RBT2-80E	1.4 (0.65)	TC62882301	TC66701401	TC62886301	TC66701301
35	38	100E	38RBA2-100E	38RBT2-100E	1.4 (0.65)	TC62882301	TC66701401	TC62886301	TC66701301
35	38	125E	38RBA2-125E	38RBT2-125E	1.4 (0.65)	TC62882301	TC66701401	TC62886301	TC66701301
35	38	150E	38RBA2-150E	38RBT2-150E	1.4 (0.65)	TC62882301	TC66701401	TC62886301	TC66701301
35	38	175E	38RBA2-175E	—	1.4 (0.65)	TC62882301	TC66701401	—	—
35	38	200E	38RBA2-200E	38RBT2-200E	1.4 (0.65)	TC62882301	TC66701401	TC62886301	TC66701301
35	38	0.5	38RBA4-.5	—	3.1 (1.4)	TC62886101	TC66701501	—	—
35	38	3	38RBA4-3	—	3.1 (1.4)	TC62886101	TC66701501	—	—
35	38	5E	38RBA4-5E	—	3.1 (1.4)	TC62886101	TC66701501	—	—
35	38	7E	38RBA4-7E	—	3.1 (1.4)	TC62886101	TC66701501	—	—
35	38	10E	38RBA4-10E	—	3.1 (1.4)	TC62886101	TC66701501	—	—
35	38	15E	38RBA4-15E	—	3.1 (1.4)	TC62886101	TC66701501	—	—
35	38	20E	38RBA4-20E	38RBT4-20E	3.1 (1.4)	TC62886101	TC66701501	TC62886501	TC66701201
35	38	25E	38RBA4-25E	38RBT4-25E	3.1 (1.4)	TC62886101	TC66701501	TC62886501	TC66701201
35	38	30E	38RBA4-30E	38RBT4-30E	3.1 (1.4)	TC62886101	TC66701501	TC62886501	TC66701201
35	38	40E	38RBA4-40E	38RBT4-40E	3.1 (1.4)	TC62886101	TC66701501	TC62886501	TC66701201
35	38	50E	38RBA4-50E	38RBT4-50E	3.1 (1.4)	TC62886101	TC66701501	TC62886501	TC66701201
35	38	65E	38RBA4-65E	38RBT4-65E	3.1 (1.4)	TC62886101	TC66701501	TC62886501	TC66701201
35	38	70E	38RBA4-80E	38RBT4-80E	3.1 (1.4)	TC62886101	TC66701501	TC62886501	TC66701201
35	38	100E	38RBA4-100E	38RBT4-100E	3.1 (1.4)	TC62886101	TC66701501	TC62886501	TC66701201
35	38	125E	38RBA4-125E	38RBT4-125E	3.1 (1.4)	TC62886101	TC66701501	TC62886501	TC66701201
35	38	150E	38RBA4-150E	38RBT4-150E	3.1 (1.4)	TC62886101	TC66701501	TC62886501	TC66701201
35	38	175E	38RBA4-175E	—	3.1 (1.4)	TC62886101	TC66701501	—	—
35	38	200E	38RBA4-200E	38RBT4-200E	3.1 (1.4)	TC62886101	TC66701501	TC62886501	TC66701201
35	38	250E	38RBA4-250E	38RBT4-250E	3.1 (1.4)	TC62886101	TC66701501	TC63943501	TC66701101
35	38	300E	38RBA4-300E	38RBT4-300E	3.1 (1.4)	TC62886101	TC66701501	TC63943501	TC66701101
35	38	450E	(2) 38RBA4-250E	(2) 38RBT2-250E	—	TC62886102	TC66701001	TC63943502	TC66700901
35	38	540E	(2) 38RBA4-300E	(2) 38RBT2-300E	—	TC62886102	TC66701001	TC63943502	TC66700901

RBA2 Fuse Holders, Mountings and Live Parts

Voltage (kV)				Style	Fuse Holder Catalog Number	Mounting Porcelain Catalog Number	Glass Polyester Catalog Number	Live Parts Catalog Number	Spring and Shunt Assembly Catalog Number
Nominal	Maximum	Ampere Rating	LIWL (BIL)						
4.8	5.5	10E–200E	60	Disconnect non-indicating	8RBA2-DH	5RBA2-PDM	5RBA2-GDM	15RBA2-DL	8RBA2-ISHNT
				Non-disconnect non-indicating	8RBA2-NH	5RBA2-PNM	5RBA2-GNM	15RBA2-NL	8RBA2-ISHNT
				Disconnect indicating	8RBA2-IDH	5RBA2-PDM	5RBA2-GDM	15RBA2-DL	8RBA2-ISHNT
				Non-disconnect indicating	8RBA2-INH	5RBA2-PNM	5RBA2-GNM	15RBA2-NL	8RBA2-ISHNT
				Non-disconnect indicating bolt in	8RBA2-INH-B	5RBA8-PNM	5RBA8-GNM	15RBA8-NL	8RBA2-ISHNT
7.2	8.3	10E–200E	75	Disconnect non-indicating	8RBA2-DH	8RBA2-PDM	8RBA2-GDM	15RBA2-DL	8RBA2-ISHNT
				Non-disconnect non-indicating	8RBA2-NH	8RBA2-PNM	8RBA2-GNM	15RBA2-NL	8RBA2-ISHNT
				Disconnect indicating	8RBA2-IDH	8RBA2-PDM	8RBA2-GDM	15RBA2-DL	8RBA2-ISHNT
				Non-disconnect indicating	8RBA2-INH	8RBA2-PNM	8RBA2-GNM	15RBA2-NL	8RBA2-ISHNT
				Non-disconnect indicating bolt in	8RBA2-INH-B	8RBA8-PNM	8RBA8-GNM	15RBA8-NL	8RBA2-ISHNT
13.8	15.5	10E–200E	95	Disconnect non-indicating	15RBA2-DH	14RBA2-PDM	14RBA2-GDM	15RBA2-DL	15RBA2-ISHNT
				Non-disconnect non-indicating	15RBA2-NH	14RBA2-PNM	14RBA2-GNM	15RBA2-NL	15RBA2-ISHNT
				Disconnect indicating	15RBA2-IDH	14RBA2-PDM	14RBA2-GDM	15RBA2-DL	15RBA2-ISHNT
				Non-disconnect indicating	15RBA2-INH	14RBA2-PNM	14RBA2-GNM	15RBA2-NL	15RBA2-ISHNT
				Non-disconnect indicating bolt in	15RBA2-INH-B	14RBA8-PNM	14RBA8-GNM	15RBA8-NL	15RBA2-ISHNT
13.8	15.5	10E–200E	110	Disconnect non-indicating	15RBA2-DH	15RBA2-PDM	—	15RBA2-DL	15RBA2-ISHNT
				Non-disconnect non-indicating	15RBA2-NH	15RBA2-PNM	—	15RBA2-NL	15RBA2-ISHNT
				Disconnect indicating	15RBA2-IDH	15RBA2-PDM	—	15RBA2-DL	15RBA2-ISHNT
				Non-disconnect indicating	15RBA2-INH	15RBA2-PNM	—	15RBA2-NL	15RBA2-ISHNT
				Non-disconnect indicating bolt in	15RBA2-INH-B	15RBA8-PNM	—	15RBA8-NL	15RBA2-ISHNT
23	25.5	10E–200E	150	Disconnect non-indicating	25RBA2-DH	25RBA2-PDM	—	38RBA2-DL	25RBA2-ISHNT
				Non-disconnect non-indicating	25RBA2-NH	25RBA2-PNM	—	38RBA2-NL	25RBA2-ISHNT
				Disconnect indicating	25RBA2-IDH	25RBA2-PDM	—	38RBA2-DL	25RBA2-ISHNT
				Non-disconnect indicating	25RBA2-INH	25RBA2-PNM	—	38RBA2-NL	25RBA2-ISHNT
				Non-disconnect indicating bolt in	25RBA2-INH-B	25RBA8-PNM	—	38RBA8-NL	25RBA2-ISHNT
34.5	38	10E–200E	150	Disconnect non-indicating	38RBA2-DH	38RBA2-PDM	—	38RBA2-DL	38RBA2-ISHNT
				Non-disconnect non-indicating	38RBA2-NH	38RBA2-PNM	—	38RBA2-NL	38RBA2-ISHNT
				Disconnect indicating	38RBA2-IDH	38RBA2-PDM	—	38RBA2-DL	38RBA2-ISHNT
				Non-disconnect indicating	38RBA2-INH	38RBA2-PNM	—	38RBA2-NL	38RBA2-ISHNT
				Non-disconnect indicating bolt in	38RBA2-INH-B	38RBA8-PNM	—	38RBA8-NL	38RBA2-ISHNT

RBA2 Exhaust Control Devices

Voltage (kV)					Exhaust Control Devices Catalog Number
Nominal	Maximum	Ampere Rating	LIWL (BIL)	Style	
4.8–13.8	5.5–15.5	10E–200E	—	Condenser (1 pack)	RBA2-COND-1
				Condenser (3 pack)	RBA2-COND
				Filter (1 pack)	RBA2-FLTR-1
				Filter (3 pack)	RBA2-FLTR
23–34.5	25.5–38	10E–200E	—	Condenser (1 pack)	RBA2-COND-1
				Condenser (3 pack)	RBA2-COND
				Filter (1 pack)	RBA2-FLTR-1
				Filter (3 pack)	RBA2-FLTR

RBA4 Fuse Holders, Mountings and Live Parts

Voltage (kV)				Style	Fuse Holder	Mounting	Glass Polyester	Live Parts	Spring and Shunt Assembly
Nominal	Maximum	Ampere Rating	LIWL (BIL)		Catalog Number	Porcelain Catalog Number	Catalog Number	Catalog Number	Catalog Number
4.8	5.5	0.5–400E	60	Disconnect non-indicating	8RBA4-DH	5RBA4-PDM	5RBA4-GDM	15RBA4-DL	8RBA4-ISHNT
				Non-disconnect non-indicating	8RBA4-NH	5RBA4-PNM	5RBA4-GNM	15RBA4-NL	8RBA4-ISHNT
				Disconnect indicating	8RBA4-IDH	5RBA4-PDM	5RBA4-GDM	15RBA4-DL	8RBA4-ISHNT
				Non-disconnect indicating	8RBA4-INH	5RBA4-PNM	5RBA4-GNM	15RBA4-NL	8RBA4-ISHNT
				Non-disconnect indicating bolt in	8RBA4-INH-B	5RBA8-PNM	5RBA8-GNM	15RBA8-NL	8RBA4-ISHNT
7.2	8.3	0.5–400E	75	Disconnect non-indicating	8RBA4-DH	8RBA4-PDM	8RBA4-GDM	15RBA4-DL	8RBA4-ISHNT
				Non-disconnect non-indicating	8RBA4-NH	8RBA4-PNM	8RBA4-GNM	15RBA4-NL	8RBA4-ISHNT
				Disconnect indicating	8RBA4-IDH	8RBA4-PDM	8RBA4-GDM	15RBA4-DL	8RBA4-ISHNT
				Non-disconnect indicating	8RBA4-INH	8RBA4-PNM	8RBA4-GNM	15RBA4-NL	8RBA4-ISHNT
				Non-disconnect indicating bolt in	8RBA4-INH-B	8RBA8-PNM	8RBA8-GNM	15RBA8-NL	8RBA4-ISHNT
13.8	15.5	0.5–400E	95	Disconnect non-indicating	15RBA4-DH	14RBA4-PDM	14RBA4-GDM	15RBA4-DL	15RBA4-ISHNT
				Non-disconnect non-indicating	15RBA4-NH	14RBA4-PNM	14RBA4-GNM	15RBA4-NL	15RBA4-ISHNT
				Disconnect indicating	15RBA4-IDH	14RBA4-PDM	14RBA4-GDM	15RBA4-DL	15RBA4-ISHNT
				Non-disconnect indicating	15RBA4-INH	14RBA4-PNM	14RBA4-GNM	15RBA4-NL	15RBA4-ISHNT
				Non-disconnect indicating bolt in	15RBA4-INH-B	14RBA8-PNM	14RBA8-GNM	15RBA8-NL	15RBA4-ISHNT
13.8	15.5	0.5–400E	110	Disconnect non-indicating	15RBA4-DH	15RBA4-PDM	—	15RBA4-DL	15RBA4-ISHNT
				Non-disconnect non-indicating	15RBA4-NH	15RBA4-PNM	—	15RBA4-NL	15RBA4-ISHNT
				Disconnect indicating	15RBA4-IDH	15RBA4-PDM	—	15RBA4-DL	15RBA4-ISHNT
				Non-disconnect indicating	15RBA4-INH	15RBA4-PNM	—	15RBA4-NL	15RBA4-ISHNT
				Non-disconnect indicating bolt in	15RBA4-INH-B	15RBA8-PNM	—	15RBA8-NL	15RBA4-ISHNT
23	25.5	0.5–300E	150	Disconnect non-indicating	25RBA4-DH	25RBA4-PDM	—	38RBA4-DL	25RBA4-ISHNT
				Non-disconnect non-indicating	25RBA4-NH	25RBA4-PNM	—	38RBA4-NL	25RBA4-ISHNT
				Disconnect indicating	25RBA4-IDH	25RBA4-PDM	—	38RBA4-DL	25RBA4-ISHNT
				Non-disconnect indicating	25RBA4-INH	25RBA4-PNM	—	38RBA4-NL	25RBA4-ISHNT
				Non-disconnect indicating bolt in	25RBA4-INH-B	25RBA8-PNM	—	38RBA8-NL	25RBA4-ISHNT
34.5	38	0.5–300E	150	Disconnect non-indicating	38RBA4-DH	38RBA4-PDM	—	38RBA4-DL	38RBA4-ISHNT
				Non-disconnect non-indicating	38RBA4-NH	38RBA4-PNM	—	38RBA4-NL	38RBA4-ISHNT
				Disconnect indicating	38RBA4-IDH	38RBA4-PDM	—	38RBA4-DL	38RBA4-ISHNT
				Non-disconnect indicating	38RBA4-INH	38RBA4-PNM	—	38RBA4-NL	38RBA4-ISHNT
				Non-disconnect indicating bolt in	38RBA4-INH-B	38RBA8-PNM	—	38RBA8-NL	38RBA4-ISHNT

RBA8 Fuse Holders, Mountings and Live Parts

Voltage (kV)					Fuse Holder	Mounting Porcelain	Glass Polyester	Live Parts	Spring and Shunt Assembly
Nominal	Maximum	Ampere Rating	LIWL (BIL)	Style	Catalog Number	Catalog Number	Catalog Number	Catalog Number	Catalog Number
4.8	5.5	450E-720E	60	Non-disconnect indicating bolt in	8RBA8-INH	5RBA8-PNM	5RBA8-GNM	15RBA8-NL	8RBA4-ISHNT
7.2	8.3	450E-720E	75	Non-disconnect indicating bolt in	8RBA8-INH	8RBA8-PNM	8RBA8-GNM	15RBA8-NL	8RBA4-ISHNT
13.8	15.5	450E-720E	95	Non-disconnect indicating bolt in	15RBA8-INH	14RBA8-PNM	14RBA8-GNM	15RBA8-NL	15RBA4-ISHNT
13.8	15.5	450E-720E	110	Non-disconnect indicating bolt in	15RBA8-INH	15RBA8-PNM	—	15RBA8-NL	15RBA4-ISHNT
23	25.5	450E-754E	150	Non-disconnect indicating bolt in	25RBA8-INH	25RBA8-PNM	—	38RBA8-NL	15RBA4-ISHNT
34.5	38	450E-754E	150	Non-disconnect indicating bolt in	38RBA8-INH	38RBA8-PNM	—	38RBA8-NL	38RBA4-ISHNT

RBA4 and RBA8 Exhaust Control Devices

Voltage (kV)					Exhaust Control Devices
Nominal	Maximum	Ampere Rating	LIWL (BIL)	Style	Catalog Number
4.8-13.8	5.5-15.5	0.5-720E	—	Condenser (1 pack)	RBA4-COND-1
				Condenser (3 pack)	RBA4-COND
				Filter (1 pack)	RBA4-FLTR-1
				Filter (3 pack)	RBA4-FLTR
23-34.5	25.5-38	0.5-540E	—	Condenser (1 pack)	RBA4-COND-1
				Condenser (3 pack)	RBA4-COND
				Filter (1 pack)	RBA4-FLTR-1
				Filter (3 pack)	RBA4-FLTR
13.2	14.4	0.5-720E	—	High capacity filter (3 pack)	RBA4-FLTR-HC-1
				High capacity filter (1 pack)	RBA4-FLTR-HC

RDB2 Outdoor Dropout Fuse Holders, Mounting and Live Parts

Ampere Rating	LIWL (BIL)	Style	Fuse Holder Catalog Number	Mounting			Live Parts		Spring and Shunt Assy Catalog Number
				Vertical Catalog Number	Underhung Catalog Number	Underhung Catalog Number	Vertical Catalog Number	Underhung Catalog Number	
10E–200E	95	Dropout	8RDB2-DH	8RDB2-VM	8RDB2-UM		RDB2-VL	RDB2-UL	8RDB2-SHNT
	110	Dropout	8RDB2-DH	8RDB2-HVM	8RDB2-HUM		RDB2-VL	RDB2-UL	8RDB2-SHNT
10E–200E	110	Dropout	15RDB2-DH	15RDB2-VM	15RDB2-UM		RDB2-VL	RDB2-UL	15RDB2-SHNT
	150	Dropout	15RDB2-DH	15RDB2-HVM	15RDB2-HUM		RDB2-VL	RDB2-UL	15RDB2-SHNT
10E–200E	150	Dropout	25RDB2-DH	25RDB2-VM	15RDB2-UM		RDB2-VL	RDB2-UL	25RDB2-SHNT
	200	Dropout	25RDB2-DH	25RDB2-HVM	25RDB2-HUM		RDB2-VL	RDB2-UL	25RDB2-SHNT
10E–200E	200	Dropout	38RDB2-DH	38RDB2-VM	38RDB2-UM		RDB2-VL	RDB2-UL	38RDB2-SHNT
	250	Dropout	38RDB2-DH	38RDB2-HVM	38RDB2-HUM		RDB2-VL	RDB2-UL	38RDB2-SHNT

RDB4 Outdoor Dropout Fuse Holders, Mounting and Live Parts

Ampere Rating	LIWL (BIL)	Style	Fuse Holder Catalog Number	Mounting			Live Parts		Spring and Shunt Assy Catalog Number
				Vertical Catalog Number	Underhung Catalog Number	Underhung Catalog Number	Vertical Catalog Number	Underhung Catalog Number	
0.5–400E	95	Dropout	8RDB4-DH	8RDB4-VM	8RDB4-UM		RDB4-VL	RDB4-UL	8RDB4-SHNT
	110	Dropout	8RDB4-DH	8RDB4-HVM	8RDB4-HUM		RDB4-VL	RDB4-UL	8RDB4-SHNT
0.5–400E	110	Dropout	15RDB4-DH	15RDB4-VM	15RDB4-UM		RDB4-VL	RDB4-UL	15RDB4-SHNT
	150	Dropout	15RDB4-DH	15RDB4-HVM	15RDB4-HUM		RDB4-VL	RDB4-UL	15RDB4-SHNT
0.5–300E	150	Dropout	25RDB4-DH	25RDB4-VM	25RDB4-UM		RDB4-VL	RDB4-UL	25RDB4-SHNT
	200	Dropout	25RDB4-DH	25RDB4-HVM	25RDB4-HUM		RDB4-VL	RDB4-UL	25RDB4-SHNT
0.5–300E	200	Dropout	38RDB4-DH	38RDB4-VM	38RDB4-UM		RDB4-VL	RDB4-UL	38RDB4-SHNT
	250	Dropout	38RDB4-DH	38RDB4-HVM	38RDB4-HUM		RDB4-VL	RDB4-UL	38RDB4-SHNT

RDB8 Outdoor Dropout Fuse Holders, Mounting and Live Parts

Ampere Rating	LIWL (BIL)	Style	Fuse Holder Catalog Number	Mounting			Live Parts		Spring and Shunt Assy Catalog Number
				Vertical Catalog Number	Underhung Catalog Number	Underhung Catalog Number	Vertical Catalog Number	Underhung Catalog Number	
450E–720E	95	Dropout	8RDB4-DH	8RDB8-VM	8RDB8-UM		RDB8-VL	RDB8-UL	8RDB4-SHNT
	110	Dropout	8RDB4-DH	8RDB8-HVM	8RDB8-HUM		RDB8-VL	RDB8-UL	8RDB4-SHNT
450E–720E	110	Dropout	15RDB4-DH	15RDB8-VM	15RDB8-UM		RDB8-VL	RDB8-UL	15RDB4-SHNT
	150	Dropout	15RDB4-DH	15RDB8-HVM	15RDB8-HUM		RDB8-VL	RDB8-UL	15RDB4-SHNT
450E–540E	150	Dropout	25RDB4-DH	25RDB8-VM	25RDB8-UM		RDB8-VL	RDB8-UL	25RDB4-SHNT
	200	Dropout	25RDB4-DH	25RDB8-HVM	25RDB8-HUM		RDB8-VL	RDB8-UL	25RDB4-SHNT
450E–540E	200	Dropout	38RDB4-DH	38RDB8-VM	38RDB8-UM		RDB8-VL	RDB8-UL	38RDB4-SHNT
	250	Dropout	38RDB4-DH	38RDB8-HVM	38RDB8-HUM		RDB8-VL	RDB8-UL	38RDB4-SHNT

2.7

Expulsion Fuses

RBA/RDB Type Fuses (Including Superseded BA Fuses)

Dimensions

Approximate Dimensions in Inches (mm)

2

RBA Fuse Mountings—RBA200, RBA400 Disconnect Mounting—4.8 to 34.5 kV

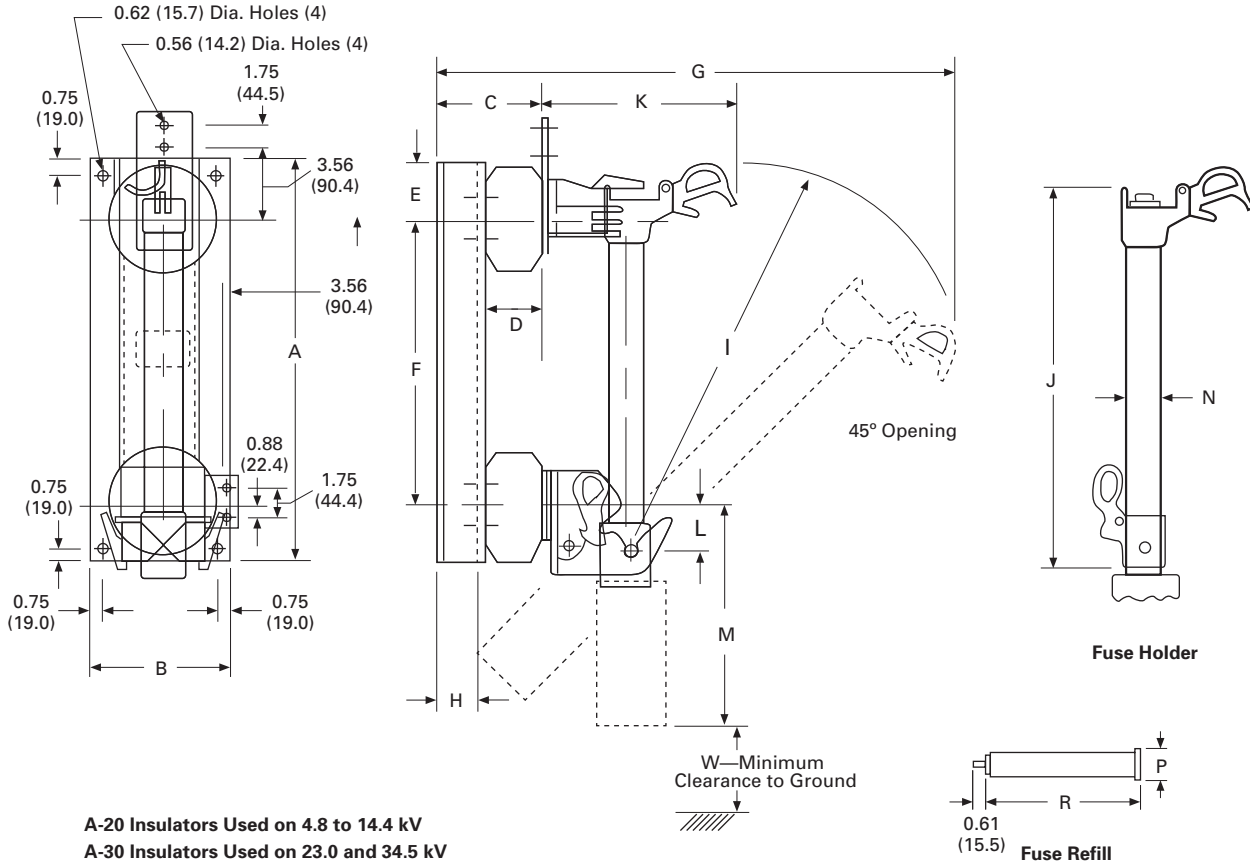

RBA/RDB Type Fuses (Including Superseded BA Fuses)

Approximate Dimensions in Inches (mm)

RBA200, RBA400

Catalog Number	kV	BIL	A	B	C	D	E	F	G	H	I	J	K	L	M	N	P	R	W With Condenser	With Discharge	Recommended Phase Spacing ^①
5RBA2	60	22.62 (574.5)	7.00 (177.8)	7.50 (190.5)	3.50 (89.9)	5.87 (149.1)	14.25 (362.0)	27.19 (690.6)	3.34 (84.8)	18.69 (474.7)	18.81 (477.7)	9.25 (234.9)	1.56 (39.6)	10.12 (257.0)	1.64 (41.7)	1.50 (38.1)	7.50 (190.5)	3.00 (76.2)	7.50 (190.5)	11.50 (292.1)	
8RBA2	75	22.62 (574.5)	7.00 (177.8)	10.00 (254.0)	6.00 (152.4)	5.87 (149.1)	14.25 (362.0)	29.69 (754.1)	6.34 (161.0)	18.69 (474.7)	18.81 (477.7)	9.25 (234.9)	1.56 (39.6)	10.12 (257.0)	1.64 (41.7)	1.50 (38.1)	7.50 (190.5)	4.00 (101.6)	8.50 (215.9)	13.00 (330.2)	
14RBA2	95	22.62 (574.5)	7.00 (177.8)	10.00 (254.0)	6.00 (152.4)	2.62 (66.5)	17.62 (447.5)	32.12 (815.8)	6.34 (161.0)	22.06 (560.3)	22.19 (563.6)	9.25 (234.9)	1.56 (39.6)	10.12 (257.0)	1.64 (41.7)	1.50 (38.1)	8.75 (222.2)	6.00 (152.4)	11.50 (292.1)	14.50 (368.3)	
15RBA2	110	22.62 (574.5)	7.00 (177.8)	11.50 (292.1)	7.50 (190.5)	2.62 (66.5)	17.62 (447.5)	33.62 (853.9)	7.84 (199.1)	22.06 (560.3)	22.19 (563.6)	9.25 (234.9)	1.56 (39.6)	10.12 (257.0)	1.64 (41.7)	1.50 (38.1)	8.75 (222.2)	6.00 (152.4)	11.50 (292.1)	16.00 (406.4)	
25RBA2	150	33.88 (860.6)	7.00 (177.8)	12.00 (304.8)	10.50 (254.0)	2.50 (63.5)	22.25 (565.1)	37.69 (957.3)	11.71 (297.4)	26.69 (677.9)	26.81 (681.0)	9.25 (234.9)	1.56 (39.6)	10.12 (257.0)	1.64 (41.7)	1.50 (38.1)	10.50 (266.7)	8.50 (215.9)	15.00 (381.0)	20.00 (508.0)	
38RBA2	150	33.88 (860.6)	7.00 (177.8)	12.00 (304.8)	10.50 (254.0)	2.50 (63.5)	29.25 (742.9)	42.62 (1082.5)	11.71 (297.4)	33.69 (855.7)	33.81 (858.7)	9.25 (234.9)	1.56 (39.6)	10.12 (257.0)	1.64 (41.7)	1.50 (38.1)	13.12 (333.2)	12.00 (304.8)	19.50 (495.3)	25.00 (635.0)	
5RBA4	60	22.25 (565.1)	7.00 (177.8)	7.50 (190.5)	3.50 (89.9)	5.94 (150.9)	13.81 (350.7)	27.40 (696.0)	3.03 (77.0)	19.69 (500.1)	20.00 (508.0)	9.25 (234.9)	2.63 (39.6)	11.75 (298.4)	2.17 (55.1)	2.20 (55.9)	7.62 (193.5)	3.00 (76.2)	7.50 (190.5)	11.75 (292.1)	
8RBA4	75	22.25 (565.1)	7.00 (177.8)	10.00 (254.0)	6.00 (152.4)	5.94 (150.9)	13.81 (350.7)	29.90 (759.5)	5.53 (140.5)	19.69 (500.1)	20.00 (508.0)	9.25 (234.9)	2.63 (39.6)	11.75 (298.4)	2.17 (55.1)	2.20 (55.9)	7.62 (193.5)	4.00 (101.6)	8.50 (215.9)	13.25 (336.5)	
14RBA4	95	22.25 (565.1)	7.00 (177.8)	10.00 (254.0)	6.00 (152.4)	2.56 (65.0)	17.19 (436.6)	32.81 (833.4)	5.53 (140.5)	23.69 (601.7)	23.38 (593.9)	9.25 (234.9)	2.63 (39.6)	11.75 (298.4)	2.17 (55.1)	2.20 (55.9)	8.88 (225.6)	6.00 (152.4)	11.50 (292.1)	14.75 (374.6)	
15RBA4	110	22.25 (565.1)	7.00 (177.8)	11.50 (292.1)	7.50 (190.5)	2.56 (65.0)	17.19 (436.6)	34.31 (871.5)	7.03 (178.6)	23.69 (601.7)	23.38 (593.9)	9.25 (234.9)	2.63 (39.6)	11.75 (298.4)	2.17 (55.1)	2.20 (55.9)	8.88 (225.6)	6.00 (152.4)	11.50 (292.1)	16.25 (412.7)	
25RBA4	150	33.81 (858.8)	8.00 (203.2)	13.50 (342.9)	10.50 (254.0)	2.50 (63.5)	21.81 (554.0)	39.56 (1004.8)	9.03 (229.4)	27.69 (703.3)	28.00 (711.2)	9.25 (234.9)	2.63 (39.6)	11.75 (298.4)	2.17 (55.1)	2.20 (55.9)	11.38 (289.1)	8.50 (215.9)	15.00 (381.0)	20.25 (514.4)	
38RBA4	150	33.81 (858.8)	8.00 (203.2)	13.50 (342.9)	10.50 (254.0)	2.50 (63.5)	28.81 (731.8)	44.50 (1130.3)	9.03 (229.4)	27.69 (703.3)	35.00 (889.0)	9.25 (234.9)	2.63 (39.6)	11.75 (298.4)	2.17 (55.1)	2.20 (55.9)	13.62 (356.0)	12.00 (304.8)	19.50 (495.3)	25.25 (641.4)	

Note

① Phase-to-phase center spacing, without barriers.

2.7

Expulsion Fuses

RBA/RDB Type Fuses (Including Superseded BA Fuses)

Approximate Dimensions in Inches (mm)

2

RBA200, RBA400 and RBA800 (Piggyback Type)—Non-Disconnect Mounting 4.8 to 34.5 kV

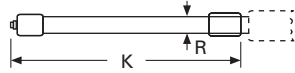
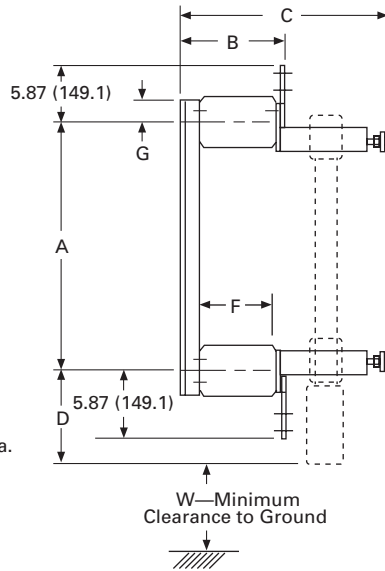
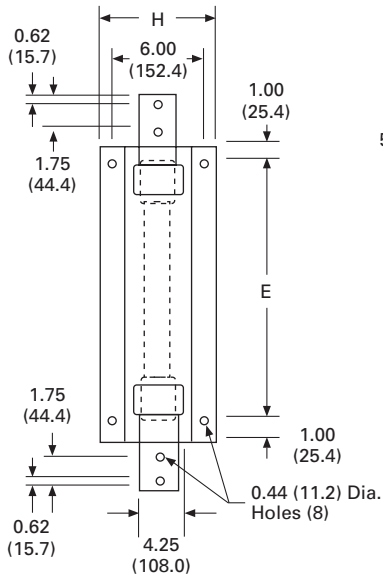

Fuse Holder RBA200, RBA400

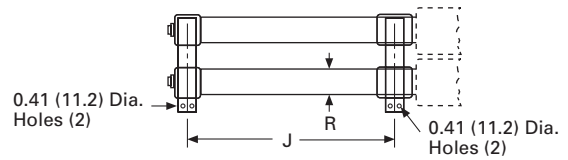
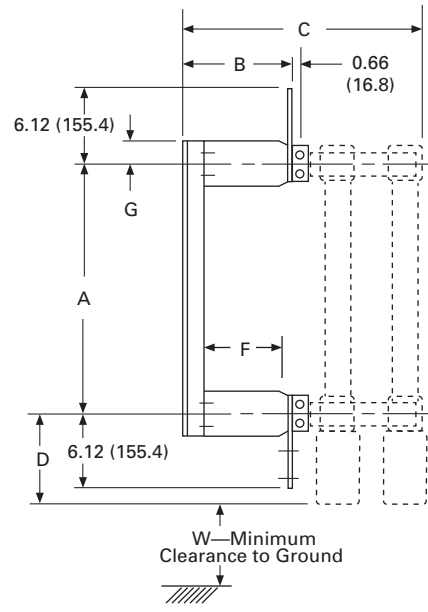

Fuse Holder RBA800

RBA/RDB Type Fuses (Including Superseded BA Fuses)

Approximate Dimensions in Inches (mm)

RBA200, RBA400 and RBA800 (Piggyback Type)

Catalog Number	kV BIL	A	B	C	D	E	F	G	H	J	K	R	W With Condenser	With Discharge	Recommended Phase Spacing ^①
5RBA2	60	15.62 (396.7)	4.62 (117.3)	11.43 (290.3)	8.62 (218.9)	15.62 (396.7)	7.50 (190.5)	1.32 (33.5)	7.50 (190.5)	—	18.25 (463.5)	1.64 (41.7)	3.00 (76.2)	7.50 (190.5)	11.16 (283.5)
8RBA2	75	15.62 (396.7)	7.12 (180.8)	13.93 (353.8)	8.62 (218.9)	15.62 (396.7)	7.50 (190.5)	1.32 (33.5)	7.50 (190.5)	—	18.25 (463.5)	1.64 (41.7)	4.00 (101.6)	8.50 (215.9)	12.56 (319.0)
14RBA2	95	19.00 (482.6)	7.12 (180.8)	13.93 (353.8)	8.62 (218.9)	19.00 (482.6)	7.50 (190.5)	1.32 (33.5)	7.50 (190.5)	—	21.63 (549.4)	1.64 (41.7)	6.00 (152.4)	11.50 (292.1)	13.06 (331.7)
15RBA2	110	19.00 (482.6)	8.62 (218.9)	15.43 (391.9)	8.62 (218.9)	19.00 (482.6)	7.50 (190.5)	1.32 (33.5)	7.50 (190.5)	—	21.63 (549.4)	1.64 (41.7)	6.00 (152.4)	11.50 (292.1)	15.56 (395.2)
25RBA2	150	26.43 (671.3)	12.12 (307.8)	18.93 (480.8)	7.25 (184.1)	29.43 (747.5)	8.50 (215.9)	2.50 (63.5)	8.50 (215.9)	—	26.25 (666.7)	1.64 (41.7)	8.50 (215.9)	15.00 (381.0)	19.56 (496.8)
38RBA2	150	33.43 (849.1)	12.12 (307.8)	18.93 (480.8)	7.25 (184.1)	36.43 (925.3)	8.50 (215.9)	2.50 (63.5)	8.50 (215.9)	—	33.25 (844.5)	1.64 (41.7)	12.00 (304.8)	19.50 (495.3)	24.56 (623.8)
5RBA4	60	16.56 (420.6)	4.62 (117.3)	12.31 (312.7)	8.75 (222.2)	16.56 (420.6)	7.50 (190.5)	1.32 (33.5)	7.50 (190.5)	—	19.52 (495.8)	2.17 (55.1)	3.00 (76.2)	7.50 (190.5)	11.16 (283.5)
8RBA4	75	16.56 (420.6)	7.12 (180.8)	14.81 (376.2)	8.75 (222.2)	16.56 (420.6)	7.50 (190.5)	1.32 (33.5)	7.50 (190.5)	—	19.52 (495.8)	2.17 (55.1)	4.00 (101.6)	8.50 (215.9)	12.56 (319.0)
14RBA4	95	19.94 (506.5)	7.12 (180.8)	14.81 (376.2)	8.75 (222.2)	19.94 (506.5)	7.50 (190.5)	1.32 (33.5)	7.50 (190.5)	—	22.90 (581.7)	2.17 (55.1)	6.00 (152.4)	11.50 (292.1)	13.06 (331.7)
15RBA4	110	19.94 (506.5)	8.62 (218.9)	16.31 (414.3)	8.75 (222.2)	19.94 (506.5)	7.50 (190.5)	2.50 (63.5)	7.50 (190.5)	—	22.90 (581.7)	2.17 (55.1)	6.00 (152.4)	11.50 (292.1)	15.56 (395.2)
25RBA4	150	27.37 (695.2)	12.12 (307.8)	19.81 (503.2)	7.37 (187.2)	30.37 (771.4)	8.50 (215.9)	1.32 (33.5)	8.50 (215.9)	—	22.90 (581.7)	2.17 (55.1)	8.50 (215.9)	15.00 (381.0)	19.56 (496.8)
38RBA4	150	34.37 (873.0)	12.12 (307.8)	19.81 (503.2)	7.37 (187.2)	37.37 (949.2)	8.50 (215.9)	2.50 (63.5)	8.50 (215.9)	—	34.52 (876.8)	2.17 (55.1)	12.00 (304.8)	19.50 (495.3)	24.56 (623.8)
5RBA8	60	16.31 (414.3)	4.50 (114.3)	12.85 (326.4)	9.31 (236.5)	17.56 (446.0)	3.50 (88.9)	1.62 (41.1)	3.50 (88.9)	16.31 (414.3)	—	2.17 (55.1)	3.00 (76.2)	7.50 (190.5)	11.00 (279.4)
8RBA8	75	16.31 (414.3)	7.00 (177.8)	15.35 (389.9)	9.31 (236.5)	17.56 (446.0)	6.00 (152.4)	1.62 (41.1)	6.00 (152.4)	16.31 (414.3)	—	2.17 (55.1)	4.00 (101.6)	8.50 (215.9)	12.50 (317.5)
14RBA8	95	19.81 (503.2)	7.00 (177.8)	15.35 (389.9)	9.31 (236.5)	21.06 (534.9)	6.00 (152.4)	1.62 (41.1)	6.00 (152.4)	19.81 (503.2)	—	2.17 (55.1)	6.00 (152.4)	11.50 (292.1)	14.00 (355.6)
15RBA8	110	19.81 (503.2)	8.50 (215.9)	16.85 (428.0)	9.31 (236.5)	21.06 (534.9)	7.50 (190.5)	1.62 (41.1)	7.50 (190.5)	19.81 (503.2)	—	2.17 (55.1)	6.00 (152.4)	11.50 (292.1)	15.50 (393.1)
25RBA8	150	24.50 (622.3)	11.50 (292.1)	19.85 (504.2)	9.31 (236.5)	27.50 (698.5)	10.50 (266.7)	2.50 (63.5)	10.50 (266.7)	24.50 (622.3)	—	2.17 (55.1)	6.00 (152.4)	15.00 (381.0)	19.50 (495.3)
38RBA8	150	31.50 (800.1)	11.50 (292.1)	19.85 (504.2)	9.31 (236.5)	34.50 (876.3)	10.50 (266.7)	2.50 (63.5)	10.50 (266.7)	31.50 (800.0)	—	2.17 (55.1)	12.00 (304.8)	19.50 (495.3)	24.50 (622.3)

Note

① Phase-to-phase center spacing, without barriers.

Eaton Current Limiting Fuses



3.1	Product Overview	
	Product Description	V14-T3-2
3.2	Fuse Selection	
	Fuse Selection	V14-T3-5
	Current Limiting Applications	V14-T3-6
3.3	Applications	
	Applications	V14-T3-11
3.4	CLE, HLE, LHLE, AHLE, BHLE, HCL and BHCL Type Fuses	
	CLE, HLE, LHLE, AHLE, BHLE, HCL and BHCL Type Fuses	V14-T3-19
3.5	CLPT and NCLPT Type Fuses	
	CLPT and NCLPT Type Fuses	V14-T3-42
3.6	ACLS, BCLS, CLS, HCLS and NCLS Type Fuses	
	ACLS, BCLS, CLS, HCLS and NCLS Type Fuses	V14-T3-50
3.7	CLT Type Fuses	
	CLT Type Fuses	V14-T3-65
3.8	CX, CXI and CXN Type Fuses	
	CX, CXI and CXN Type Fuses	V14-T3-67
3.9	DSL, MDSL and NPL Type Low Voltage Current Limiters	
	DSL, MDSL and NPL Type Low Voltage Current Limiters	V14-T3-76

Current Limiting Fuses



Product Description

Introduction

Eaton's medium voltage fuses provide diverse characteristics that allow them to be used in any application within their practical range. This difference is due to the offering of both expulsion and current-limiting fuses. Expulsion and current-limiting fuses employ different interrupting techniques that cause the criteria with which they are employed to differ. This requires that a different set of questions should be answered when applying expulsion and current-limiting fuses. For this reason, and to avoid confusion, this application data applies only to current-limiting fuses. For information on the application of expulsion fuses see Eaton's Expulsion Fuse Product Focus.

Available Types

Current ANSI/IEEE fuse standards define three types of current-limiting fuses: back-up fuses, general-purpose fuses and full-range fuses. It is important for the user to have an understanding of these definitions to ensure proper application of the fuse.

A **backup current-limiting fuse** is able to safely interrupt all values of fault current from the rated minimum interrupting current up to the rated maximum interrupting current of the fuse.

Although only backup current limiting fuses make a specific reference to a rated minimum interrupting current, general-purpose and full-range define a rated minimum interrupting current in different terms.

The rated minimum interrupting current of a general-purpose fuse is the current that causes the fuse to operate in one hour, and the rated minimum interrupting current of a full-range fuse is the minimum value of current that will melt the fusible element(s) under specified conditions.

Generally, Eaton's backup current-limiting fuses are the R-rated range, which have a rated minimum interrupting current equivalent to the 100 second current on the minimum melting time-current curve. This point is not necessarily the limit of low fault performance, merely the required limit of low fault performance, in line with the normal application practices for this type of fuse,

Contents

Description

	<i>Page</i>
Construction	V14-T3-3
Interruption and Operation	V14-T3-3
Application	V14-T3-4
Mountings	V14-T3-4

which is used for high fault protection of medium voltage motor starters in conjunction with relays and overload contactors.

Eaton's R-rated backup fuses may be thermally damaged or may not operate correctly if subjected to overload currents greater than those shown on the safe overload curves and the rated minimum interrupting current for long times.

A **general-purpose current-limiting fuse** is able to safely interrupt all values of fault current from the current that causes the fuse to operate in one hour or more up to the rated maximum interrupting current of the fuse.

The one hour melting time is with the fuse in a conventional mount, and in a 25°C ambient. Other mountings or ambient conditions may cause the fuse to melt earlier, but this does not alter this rated minimum interrupting current. Eaton's general purpose current-limiting fuses are used to protect circuits feeding transformers and feeders, where there is downstream protection that will operate before the medium voltage general-

purpose fuse is affected by a long term overload. See application notes on feeder and transformer protection for details. Eaton's E-rated general-purpose fuses may be thermally damaged or may not operate correctly if subjected to overload currents greater than those shown on the safe overload curves and the indicated one hour interrupting current for long times.

A **full-range current-limiting fuse** is able to safely interrupt all values of fault from the minimum value of current that will melt the fusible element up to the rated maximum interrupting current under specified conditions.

Eaton's full range current-limiting fuses are used to protect circuits feeding transformers and feeders, where there may not be any effective downstream protection.

Construction

Current-limiting fuses are sometimes referred to as silver-sand fuses. This reference comes from the fact that calibrated pure silver current responsive elements are surrounded by pure silica or quartz sand with controlled grain size that acts as a cooling and absorbing agent when the fuse interrupts a fault. Interruption of a fault by a current-limiting fuse is quiet and completely self contained. In general, pure silver is used for the elements in Eaton current limiting fuses because it provides the ideal mix of physical characteristics. With uniquely designed element constructions for each class, these current limiting fuses offer the highest available ratings in the smallest barrel sizes. All components are housed in a fiberglass reinforced resin tube with plated copper contact caps that are magna-formed onto the housing for optimum strength and filled with high purity silica sand. Blown fuse indication is provided by either a striker pin or a pop-up button. A durable nameplate label provides rating and manufacturer information.

Interruption and Operation

Current limiting fuses operate in two modes, depending on the magnitude of the fault current. The first is operation in the overload mode where the fault current is below the threshold current for the fuse. In this mode, the fuse does not operate during the first major half cycle, and does not limit the magnitude of the fault current. The second is operation in the short-circuit or current-limiting mode where the current is above the threshold current for the fuse. In this mode, the fuse does operate during the first major half cycle, and does limit the magnitude of the fault current.

There is a small overlap zone between the overload and short-circuit modes of operation, where the fuse may or may not act in the current-limiting mode. The performance of the fuse in this zone is dependent on circuit conditions such as the power-factor of the circuit, and the point on wave of the inception of the fault. The threshold value for any particular fuse can be read off the peak let-through (cut-off current) chart. The threshold current is the value of available current in amperes on the horizontal axis that corresponds to the intercept of the individual fuse line and the peak asymmetrical available diagonal line.

In the overload mode, the fuse does not limit the peak value of the current, as in this mode, it carries one or more full half cycles of current before the current responsive element(s) melt open. After the current responsive element(s) melt open, they will arc until they have burnt back far enough to interrupt the overload current and withstand the circuit recovery voltage.

In the short-circuit mode, the fuse element(s) melt almost instantaneously, producing a number of series arcs at the neck points on the elements. The interaction of these series arcs and the constraining medium (typically sand) introduces a rapidly rising resistance into the fault circuit that limits the peak value of the current to a value considerably less than the peak value of the prospective current wave. The stored energy in the circuit causes current to continue to flow through the fuse until it is dissipated and this produces a high arc voltage across the fuse. The fuse changes a high current low power factor circuit into a lower current, higher power factor circuit, and as a result, the current is forced to near zero well before the natural current zero of the circuit. Because the current is forced to zero before the natural current zero of the circuit, the effects of transient recovery voltage of the circuit are reduced because the current and voltage are nearly in phase. Current-limiting fuses are thus relatively insensitive to the transient recovery voltage.

CL Fuse Operation

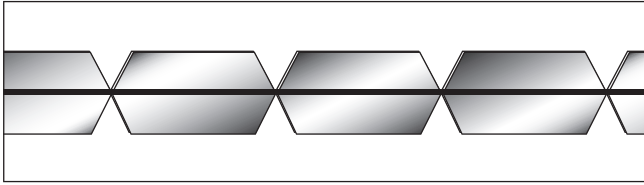

Element melts forming multiple series arcs at element necks

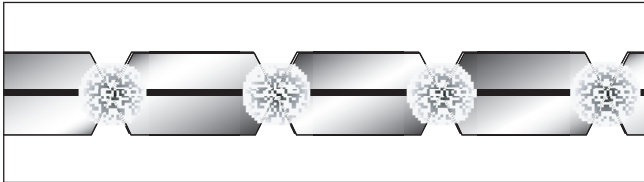

Heat from arcing melts the sand into a glass-like structure referred to as "fulgurite"

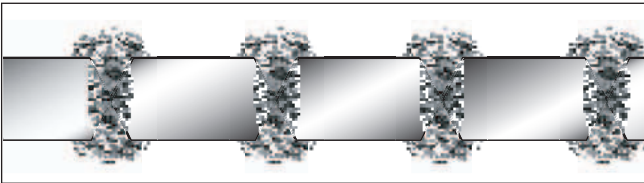

Fulgurite absorbs the heat from the arcs but also encloses them, depressing current peak value

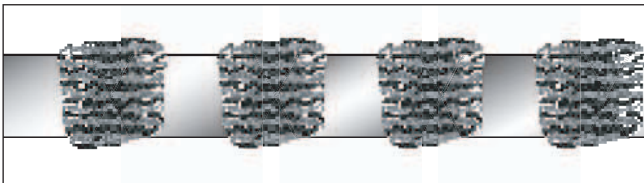

Arc is extinguished as current is forced to zero

Because of the limitation of the peak value of the current, and the early extinction of the current, the energy let through by the fuse in the short-circuit mode is considerably lower than the energy that would have been let through by the unaltered prospective current wave. This significantly reduces energy let through and can protect the circuit from mechanical and thermal damage that would be caused in the absence of the current-limiting fuse.

Eaton's current-limiting fuses produce arc voltages that are within the limits specified in the applicable C37 standards. The arc voltage is seen on the supply side of the fuse, but is not normally seen on the load-side of the fuse.

Application

Eaton offers a wide range of interrupting ratings in single barrel designs with ratings extended to higher currents in double, triple and quad barrel designs. E-rated fuses are available in both long (CLE) and short (HLE) clip center designs. BHLE and HCL versions are available for bolt-in and clamp in mounting arrangements. R-rated motor starter fuses for standard clip mounting (CLS), are also available with an integral hookey for Eaton's Ampgard™ starter assemblies (ACLS) or bolt-in style mounting (BCLS). CLPT fuses are available for potential transformer protection in several different diameters. CX and CLT fuses are ideally suited for canister applications and available in a wide range of ratings. Low voltage current limiters, MDSL for Magnum and DSL breakers and NPL for network protectors, which are not covered in this catalog, are also available in a variety of current ratings.

Mountings

Eaton's current-limiting fuses are available in industry-standard mounting sizes. Disconnect and non-disconnect mountings are available for most fuse case sizes. Mountings include the base, porcelain or glass polyester insulators and live parts. Live parts, fuse clips and fuse end fittings are also available separately. All Eaton's current-limiting fuses and mountings are easy to install and operate.

Current Limiting Fuses



Contents

Description	Page
Fuse Selection	
Current Limiting Applications	V14-T3-6
Voltage Rating	V14-T3-6
Interrupting Rating	V14-T3-6
Continuous Current Rating	V14-T3-7
Fuse Enclosure Packages	V14-T3-8
Parallel Fuses	V14-T3-8
Coordination	V14-T3-8
Interchangeability	V14-T3-9
Specific Applications	V14-T3-9
Let-Through Current	V14-T3-10
Fuses and Lightning Arresters	V14-T3-10

Fuse Selection

There are four major considerations involved in the selection of a current limiting fuse. The first three considerations are the voltage rating, the interrupting rating and the continuous current rating of the fuse. Proper attention should be given to each of these considerations as improper application in any one area may result in the fuse failing to perform its intended function. The fourth consideration is coordination with line and load side protective equipment that is needed to give selectivity of outage and to prevent premature fuse operation. Each of the four areas is discussed here individually.

Current Limiting Applications

Voltage Rating

The rated maximum power frequency voltage of a current-limiting fuse is the maximum rms value of circuit voltage at which the fuse has been demonstrated to be able to operate with specified circuit fault conditions. A fuse must not be applied at any location where the circuit voltage exceeds the rated maximum power frequency voltage of the fuse.

Voltage ratings of particular fuse types are listed in the appropriate fuse data sheets.

The first rule regarding fuse application is that the fuse selected must have a maximum design voltage rating equal to or greater than the maximum power frequency voltage that will be available in the system in which the fuse is installed under all possible conditions. In most cases this means the maximum design voltage of the fuse must equal or exceed the system maximum line-to-line voltage. The only exception to this rule occurs in distribution systems when fusing single-phase loads connected from line-to-neutral on a four-wire effectively grounded system. Here the fuse maximum design voltage need only exceed the system maximum line-to-neutral voltage providing it is impossible under all fault conditions for the fuse to experience the full line-to-line voltage. When only one phase of a four-wire effectively grounded system is extended beyond the fuse to supply a single-phase load connected from phase-to-neutral, it is acceptable to have the fuse maximum design voltage equal or exceed the system maximum line-to-neutral voltage.

It is good practice that if more than one phase of the system is extended beyond the fuse location, the fuse maximum design voltage should equal or exceed the system maximum line-to-line voltage regardless of how the three-phase system is grounded on the source side of the fuse or how the transformers or loads are connected on the load side of the fuse.

It is a common practice, however, to choose to fuse wye grounded wye transformers on the primary side with fuses with a voltage rating that only exceeds the system line-to-neutral voltage. In most cases this presents no problems but the user should be aware of the remote possibility of a secondary phase-to-phase ungrounded fault that could impose full line-to-line voltage across the fuse.

The interrupting action of current limiting fuses produces arc voltages that can exceed the system voltage. Care must be taken to ensure that these arc voltages do not exceed the insulation level of the system. If the fuse voltage rating is not permitted to exceed 140 percent of the system voltage, the arc voltages will generally not create problems. This 140 percent limit on the voltage rating over system voltage does not restrict the use of a higher rated fuse if the system has a high enough insulation level to withstand the short time application of the arc voltage. Eaton's current limiting fuses are designed so that the arc voltage peak at rated interrupting current is less than three times that of the nominal voltage rating. If the system can withstand this peak the higher rated fuse may be used.

Probably the most common problem created by high arc voltages is the sparking over of lightning arresters. As this is a common problem, it is discussed in detail in the section Fuses and Lightning Arresters.

It should be remembered that in most cases the fuse voltage rating should not exceed the system voltage by more than 40% and under no circumstances may the system voltage exceed the maximum design voltage rating of the fuse. The altitude at which a current-limiting fuse is applied must also be considered. The dielectric strength of air decreases with increases in altitude, necessitating a modification to the voltage rating above 1000m.

Altitude correction factors are listed in Annex B of IEEE Std. C37™.100.1.

Interrupting Rating

The rated maximum interrupting current of a current-limiting fuse is the rms value of the symmetrical AC component of the highest current that the fuse has been demonstrated to be able to successfully interrupt under any possible condition of asymmetry with specified circuit conditions. A fuse must not be applied at any location where the available fault current exceeds the rated maximum interrupting current of the fuse.

In general, current-limiting fuses are not sensitive to higher levels of interrupting current. Interrupting ratings are normally based on market requirements and economic cost or availability of testing facilities.

Interrupting ratings of particular fuse types are listed in the appropriate fuse data sheets.

Asymmetry Factors

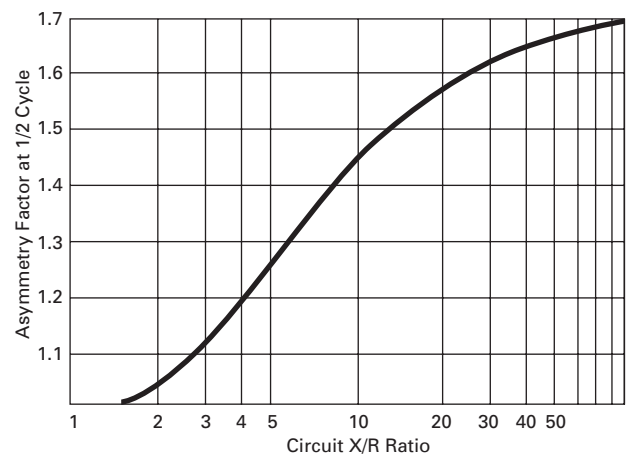

Historically, current limiting fuses had been assigned asymmetrical interrupting ratings and MVA interrupting ratings. Compliance with the test requirements in IEEE Std. C37.41™-2000 for current limiting fuses ensures that Eaton's fuses are tested under peak asymmetry conditions. Fuses are not constant kVA devices; if the circuit voltage is reduced, the interrupting capacity is not increased. The kVA interrupting rating is reduced if the fuse is applied at a lower value of circuit voltage.

The peak asymmetry factor in the first half cycle is a function of the circuit X/R ratio of the circuit, and the relationship is shown on **Page V14-T3-6**. The theoretical maximum value of the asymmetry factor in a purely inductive circuit would be 1.732. However, with the X/R values encountered in power circuits, the factor is rarely more than 1.6.

In the past, fuses were sometimes rated by nominal three-phase kVA ratings. The nominal three-phase kVA rating was calculated by the formula $kVA = I \times kV \times 1.732$, where I is the rated maximum interrupting current in symmetrical rms amperes and kV is the nominal fuse voltage rating.

When a current-limiting fuse interrupts a fault current above its threshold current, it will limit the amplitude of the current in the first major loop. The level of current limitation, measured by the ratio of peak circuit available current to the fuse peak let-through current increases as the value of symmetrical available current increases above the fuse threshold current. In addition to controlling the amplitude of the let-through current, a current-limiting fuse can also cause the current to be extinguished significantly earlier than the natural current zero of the circuit.

The altitude at which a current-limiting fuse is applied must also be considered. The dielectric strength of air decreases with increases in altitude, necessitating a reduced interrupting rating above 1000m (3280 ft).

Altitude correction factors are listed in Annex B of IEEE Std. C37.100.1™.

A general purpose current limiting fuse can have some limits on interrupting low currents. General purpose fuses are fault protective but not overload protective. They do not provide protection for values of overload current in the range of one to two times the fuse continuous current rating.

A back-up current limiting fuse only protects against high values of fault current, and must be applied with another series protective device. For lower values of fault current, below the minimum interrupting current of the fuse, the series protective device must interrupt these lower values of fault current.

Continuous Current Rating

Eaton current limiting fuses have been demonstrated to be able to carry their rated current continuously without exceeding the temperature rise values permitted by C37.40.

Continuous current ratings of particular fuse types are listed in the appropriate fuse data sheets.

Eaton current-limiting fuses have A-, C-, E-, R-, X- or dual E/X-ratings.

An A-rating indicates that the value before the A is the rated continuous current of the fuse.

A C-rating indicates that the value before the C is the rated continuous current of the fuse, and that the calibrated current-responsive element will melt in 1000 seconds at an rms current within the range of 170 to 240% of the rated continuous current.

The C-requirement is specified in ANSI C37.47™.

An E-rating (100E or less) indicates that the value before the E is the rated continuous current of the fuse, and that the calibrated current-responsive element will melt in 300 seconds at an rms current within the range of 200 to 240% of the rated continuous current.

An E-rating (greater than 100E) indicates that the value before the A is the rated continuous current of the fuse, and that the calibrated current-responsive element will melt in 600 seconds at an rms current within the range of 220 to 264% of the rated continuous current.

The E-requirements are specified in ANSI C37.46.

Some Heritage Westinghouse CLE fuses were assigned an X-rating that indicates that the value before the X was the rated continuous current of the fuse, but the fuse design did not satisfy the E-requirements specified above. Other Heritage Westinghouse CLE fuses were assigned dual E- and X-ratings, where the lower value satisfied the E-requirements above, but the fuse could also carry a higher value of continuous current without exceeding the temperature rise values permitted by C37.40, the X-rating.

An R-rated fuse has current responsive elements calibrated to melt between 15 and 35 seconds when subjected to a current of 100 times the R value. These fuses also have temperature rise requirements at specific values of current.

The R-requirement is specified in ANSI C37.46.

E- and X-rated fuses are power class fuses, used in transformer and feeder circuits.

R-rated fuses are power class fuses, and are used specifically in medium voltage motor controllers.

C-rated fuses are distribution class fuses, and are used mainly in transformer circuits.

A-rated fuses can be distribution or power class fuses.

An E- or C-rating only define one gate on the time-current curve of the fuse, and does not imply interchangeability between fuses from different manufacturers.

There are also significant differences between the time-current curves of E-rated current-limiting and E-rated expulsion fuses, both in the low overcurrent and high fault current areas. E-ratings for expulsion fuses generally give a 2:1 ratio of minimum melting current to continuous current rating. However, E-ratings for current-limiting fuses generally give a 1.6 to 1.8 ratio of minimum melting current to continuous current rating.

If the fuse is subjected to a current below the 330, 600, or 1000 second melting current as stated in the E or C fuse definitions, but substantially above the continuous current rating of the fuse for an excessive length of time, a large amount of heat is generated and this may cause damage to the fuse, adversely affecting the fuse integrity or changing the time-current characteristics of the fuse. Specific allowable overload characteristics for general-purpose and full-range current-limiting fuses must not be exceeded under any circumstances. If back-up fuses are properly applied with a suitable low current protection device to clear low fault currents, overloads should not present a problem.

In practice, current-limiting fuses are used to protect circuits feeding transformers, motors and other equipment where overloads and inrush currents are common. Current-limiting fuses have a rather low thermal capacity and cannot carry overloads of the same magnitude and duration as transformers and motors of equal continuous current rating. For this reason, a general fuse application ratio of 1.4:1 fuse continuous current rating to full load current is suggested so the fuse will not operate on acceptable overloads and inrush conditions. This is a general figure for typical applications and that a ratio as low as 1:1 can be used if the system current will never exceed the rated current of the fuse.

In other applications, a higher ratio will be required to prevent the fuse from operating on transformer inrush or motor starting current or from being damaged due to severe overloading. More specific application information can be found in the individual application sections that follow.

Under no circumstances must the fuse continuous current rating be less than continuous load current and that E- and C-rated fuses may not provide protection for currents in the range of one to two times the continuous current rating.

Fuse Enclosure Packages

It is quite common for current-limiting fuses to be mounted in a fuse enclosure package such as a switch in an enclosure that is surrounded by air, or a transformer draw-out well that is mounted in the transformer and surrounded by hot oil. Fuse enclosure package classes are defined in ANSI C37.40.

Due to the elevated ambient temperature produced by these enclosure packages, it is sometimes necessary to derate the continuous current

rating of the fuse. When an Eaton fuse is to be used within an enclosure, be sure to check with the manufacturer of that enclosure and use the suggested current rating or apply the suggested derating factor if one is necessary.

Parallel Fuses

At times it is desirable to have a continuous current rating larger than any single fuse barrel can provide. Higher ratings can be obtained by paralleling fuses. Two, three and four barrel designs are available. Consult Eaton for specific guidance. Under no circumstances should fuses be paralleled unless the paralleling is one of the extensively tested Eaton designs.

Coordination

In addition to selecting a fuse that meets the voltage, interrupting and continuous current requirements for the application, it is also important to ensure that the melting and clearing performance of the fuse protects and coordinates adequately with other circuit components. Eaton publishes minimum melt and total clear time-current characteristics, and minimum melting and total clearing I^2t values to assist with this coordination. The minimum melt curve gives the minimum melting time in seconds of the fusible element(s) at a particular value of symmetrical rms current under specified temperature conditions and without pre-loading. The total clearing curve gives the maximum clearing time in seconds to complete interruption of the circuit at a particular value of symmetrical current under specified conditions. The range between the minimum melting and the total clearing time current curves includes an allowance for manufacturing tolerances, and the arcing time of the fuse after melting. Arcing time is time in seconds lapsing from the melting of the fusible element(s) to the

final interruption of the circuit. The minimum melting and total clearing I^2t values indicate fuse and circuit damage energy values and are used only for fault currents that melt the fuse elements in less than 0.1 second, that is, above the threshold value for the fuse.

As previously mentioned, three types of current-limiting fuses are defined in ANSI/IEEE standards. Full-range fuses will interrupt any value of current from the interrupting rating down to that which will cause the element(s) to melt under specified conditions. General-purpose fuses will interrupt any value of current from the interrupting rating down to a current that will melt the element(s) in one hour under specified conditions. Back-up fuses will interrupt any current from the interrupting rating down to the rated minimum interrupting current. When coordinating using a full-range or general-purpose fuse, it is necessary

to ensure the current does not exceed the fuse overload characteristics. If back-up fuses are used, ensure that another device that will clear fault currents below the minimum interrupting current of the fuse is used.

Proper coordination of current-limiting fuses in the overload mode is ensured by keeping the fuse minimum melting curve above the total clearing curve of any downstream overcurrent protective device, and keeping the fuse total clearing curve beneath the minimum operating curve of any upstream protective equipment. Coordination in the short-circuit zone is achieved by simply using the I^2t values, and keeping the minimum melting I^2t of the fuse above the total clearing I^2t of any downstream protective device, and keeping the total clearing I^2t of the fuse beneath the damage value of the upstream equipment.

Allowable Overload Factors

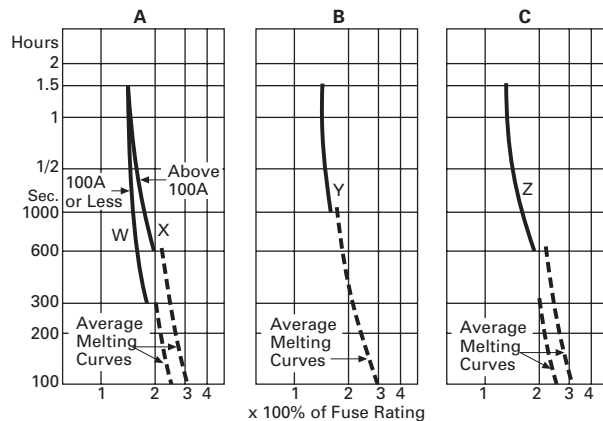

W = E rated general purpose type fuse 100A or less except 15.5 kV CLE
 X = E rated general purpose type fuse above 100A except 15.5 kV CLE
 Y = C rated general purpose type fuse
 Z = General purpose fuse CLE 15.5 kV only

Effects of Ambient Temperature on Melting Curves

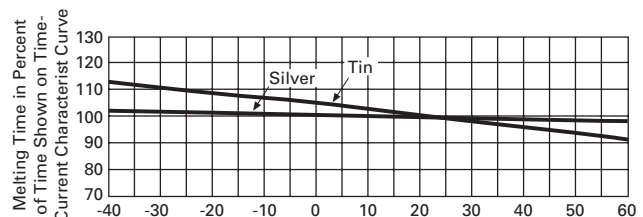

Time-current curves for Eaton's current-limiting fuses are based on standard conditions of temperature and altitude, and the zone between the minimum melting and total clearing characteristics allows for manufacturing tolerances. Preloading and elevated ambient temperatures are not allowed for. It is recommended that a safety zone be used when applying current-limiting fuses to ensure that proper coordination is maintained to allow for these factors. There are two approaches used to achieve this safety zone and both produce similar results. One approach employs a 25% safety zone in time for a given value of current and the other uses a 10% safety zone in current for a given value of time. Eaton uses the second method as it allows the safety zone to be published on the left-hand side of all the time-current curves. Coordination is then achieved by overlaying curves and shifting one by the width of the published safety zone.

If desired or if unusual conditions exist, shifts in the time-current curve due to ambient temperature and preloading may be examined individually. Eaton's time-current characteristics are derived from tests on fuses surrounded by freely circulating air at an ambient temperature of 25°C and with no initial preloading as specified in C37.40. Fuses subjected to conditions other than the above will experience shifts in the time-current curves. The upper right curve gives the adjusting factors for changes in ambient temperature and also the adjusting factors for preloaded fuses. These adjusting factors are valid only for Eaton's power fuses.

The lower right curve gives an example of a properly coordinated fuse application. The figure shows a general-purpose CLE fuse protecting the primary of a 1000 kVA transformer with Eaton's type

DS or Magnum low voltage air circuit breakers protecting the secondary equipment.

Coordination with reclosing circuit breakers may be performed with the aid of the proper coordination chart. This type of curve is explained in the repetitive faults section of the application data.

Interchangeability

C-, E- and R-ratings define the performance of a fuse at one particular point on the time-current curve. However, the fuse performance at other values of current are shown by each manufacturer's published time-current curves. Since these curves are a function of the distinctive current responsive elements used by each manufacturer, fuses with the same C-, E- or R-ratings from different manufacturers may not be interchangeable in all applications. Users must also be aware that E-rated current limiting type and E-rated expulsion type fuses have very different time-current and short circuit characteristics. It is the responsibility of the user to ensure that the physical dimensions and electrical characteristics of the fuse are appropriate for the particular application in the intended equipment.

Specific Applications

There are aspects to be considered other than voltage rating, interrupting rating and continuous current rating. One concerns the types of current-limiting fuses: full-range fuses, general-purpose fuses and back-up fuses. Full-range and general-purpose fuses are normally applied without supplementary protection in the medium voltage system. These fuses are used on transformer and feeder applications. General-purpose fuses are used in power transformer circuits where secondary side protective devices will clear secondary faults. Full-range fuses are used in distribution transformer circuits where

there may not be protection on the secondary side of the transformer and the primary fuse may be called upon to clear a secondary system fault. A back-up fuse must have another medium voltage protective device so that it will not be called upon to interrupt currents below its

specified minimum interrupting rating. An example of a properly applied medium-voltage back-up current-limiting fuse is in a motor starter unit where the CLS fuse is used in series with a relay and contactor to protect it from faults that exceed the contactor rating.

Pre-Loading Adjustment Factors for Power Fuses

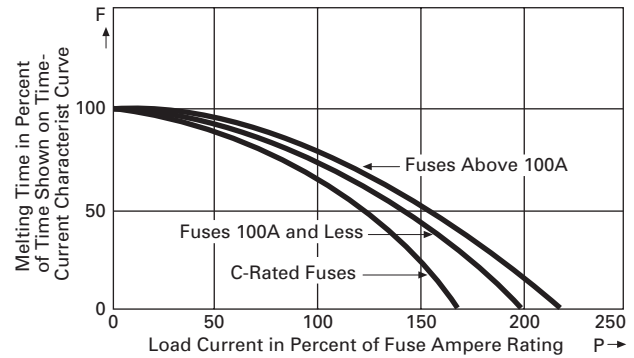

Typical Fuse Coordination

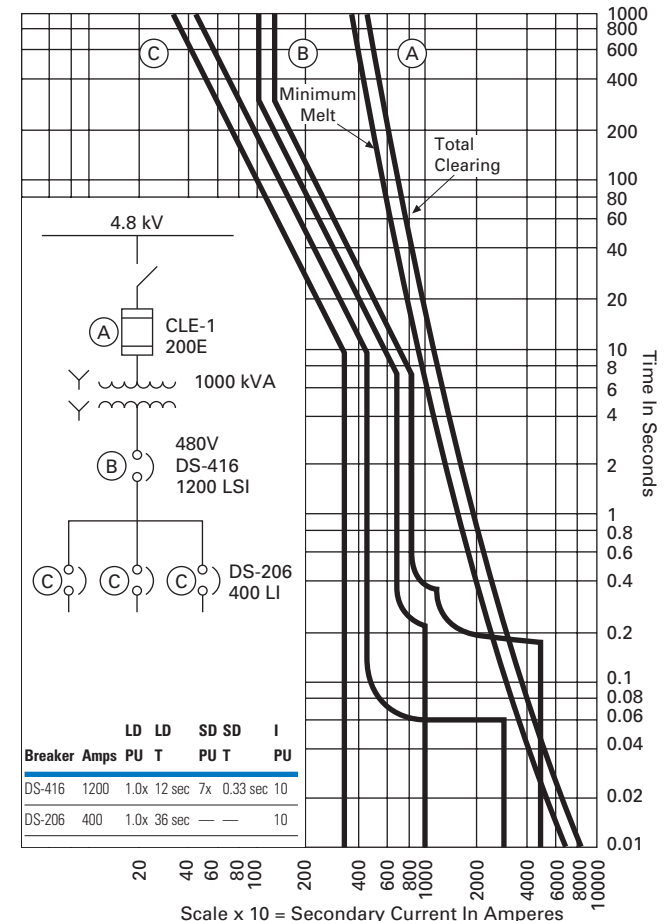

Let-Through Current

An important feature of current-limiting fuses is the limitation of fault current and energy seen by the system being protected. Although a current-limiting fuse is not current-limiting for values of fault current below the threshold current of the fuse, these lower values of fault currents do not present problems due to the low energy. For currents equal to or greater than its threshold current, the fuse will limit the current let-through to the system. The value of this let-through current is dependent on the particular fuse type, the magnitude of the fault current and the timing of the fault initiation—the power

factor of the circuit only has a minimal effect.

If the timing of the fault is such that fuse melts after the current has crested, the fuse will not limit the peak current because the peak has already passed. With a fully asymmetrical fault, the available current would have crested in 1/4 cycle. However, the presence of the fuse in the circuit will limit the peak value of current, and have caused the current to have peaked before the 1/4 cycle time. Thus, the current-limiting action varies with the degree of asymmetry of the fault.

Eaton publishes let-through curves that are based on power circuits with an X/R ratio greater than 15. The curve below shows a typical let-through curve. The horizontal axis gives the rms symmetrical available fault and the vertical axis the peak instantaneous let-through current. Let-through current for any particular fuse may be found by choosing the curve for the fuse in question and reading the let-through for any given value of available fault. The point where the curve intersects the asymmetrical available peak line is the threshold current (for that fuse) or that point where the fuse first become current limiting. Curves like this are found in Eaton's current-limiting fuse application data and make it easy to check the fuse let-through against the withstand of the equipment it is protecting.

into arresters that are not designed for such interrupting duty.

This problem could be eliminated by mounting the fuse on the line side of the arrester, but this is not always practical. Many utilities prefer to apply the fuse on the load side of the arrester to eliminate possible fuse damage that might result from lightning. Other utilities employ transformers with bushing mounted current-limiting fuses where the fuse must be installed on the load side of the arrester.

For current-limiting fuse applied on the load side of a distribution arrester, arc voltages do not affect the arrester if the fuse and the arrester have the same voltage rating; however, if an arrester on the line side has a voltage rating lower than that of the fuse, it may sparkover. Under this condition the arrester and the fuse will share the current. Distribution type arresters have higher impedances that keep them from experiencing excessive amounts of current and they are not usually damaged. Intermediate and station type arresters on the other hand have lower impedances that allow them to experience higher currents and they may become damaged. Therefore, station and line type arresters should not be applied on the line side or in parallel with current-limiting fuses unless their sparkover value is greater than the maximum arc voltage the fuse can produce.

Machine protection arresters are purposely designed to have low sparkover values. They should, however, be connected directly to the machine terminals and not on the line side of the fuse. If properly connected, the fuse arc voltage can have no effect on them.

Correctly applied distribution class lightning arresters found on the line side of the fuse have sparkover values sufficiently high to remain unaffected by fuse operations.

Typical Peak Let-Through Current Curves

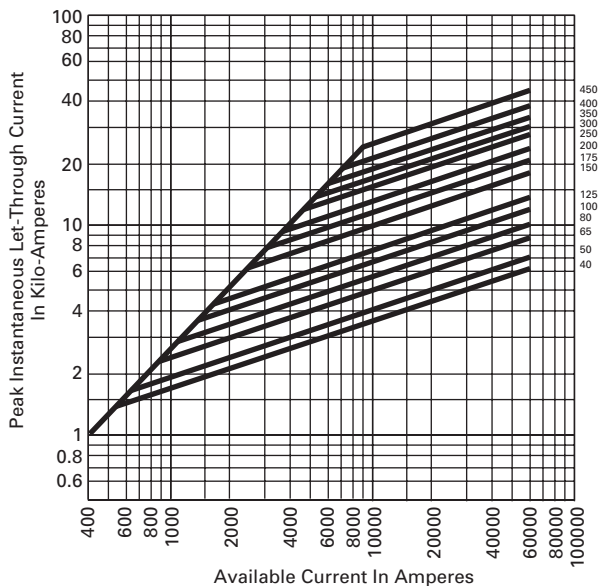

Fuses and Lightning Arresters

Current-limiting fuses generate arc voltages that are higher than the system power frequency voltages. The magnitude of arc voltage generated is dependent on the element design, element length, and the type and size of filler. A strip type element, for example, generates arc voltages that are more dependent on the system voltage, whereas a uniform cross section wire element produces arc voltages dependent on the fault current value. Users of current-limiting fuses are not generally aware of the fuse design so a general estimation of generated arc voltage is needed. Eaton's current-limiting fuses perform their function by generating arc voltages that may peak as high as three times the nominal voltage rating of the fuse at its interrupting rating.

When applying current-limiting fuses, care should be taken to see that arc voltages produced by the fuse do not exceed the insulation level of the system. An examination of the insulation level of the system will show that lightning arresters are the principal equipment to check. If arc voltages cause interconnected lightning arresters to operate, a relatively high current would be shunted

CLPT Fuses



Applications

Transformer Applications

Fuses are installed on the primary side of a transformer to:

- Protect the system on the source side of the fuses from an outage due to faults in or beyond the transformer (isolate a faulted transformer from an otherwise healthy distribution system to prevent further disturbance). In the case of an internal winding fault in the transformer, the fuse should prevent further collateral damage to the transformer and its surroundings. Current-limiting fuses are generally better able to limit internal damage to the transformer than expulsion fuses
- Coordinate with protection on the low voltage side of the transformer (transformer primary protection must be overload tolerant, allowing the secondary protection to clear faults occurring downstream of the secondary protection)
- Protect the transformer against bolted secondary faults (the fuse should operate on any bolted secondary faults between the transformer secondary terminals and the

secondary protection before the transformer is damaged)

- Protect the transformer against higher impedance secondary faults to whatever extent is possible (the fuse should limit damage to the transformer windings to the best extent possible)

Selecting the proper voltage and interrupting ratings for the fuse is straightforward and has been sufficiently covered in their respective sections.

There are two sometimes conflicting factors when selecting a fuse to protect a transformer circuit. The continuous current rating must be large enough to prevent premature fuse interruption from magnetizing or inrush currents and it must also be large enough to prevent fuse deterioration or fuse interruption during normal or emergency overload situations. The fuse continuous current rating must also be small enough to provide the protection listed in the purpose hierarchy. In practice, it is not always possible to select a fuse large enough to allow for all the overloading required and still

Contents

Description

Page

Applications

Potential and Control Transformer Application	V14-T3-16
Motor Protection	V14-T3-16
Repetitive Faults	V14-T3-17

provide complete protection for the transformer. In these cases, the user should decide how the priorities lie and trade off overloading ability for transformer protection.

Fuses on the primary side of transformers should not operate on transformer magnetizing inrush current. The magnitude of the first loop of inrush current and the rate at which the peaks of subsequent loops decay is a function of many factors. Some of these are transformer design, residual flux in the core at the instant of energization, the point on the voltage wave at which the transformer is energized, and the characteristics of the source supplying the transformer. When energizing, the heating effect of the inrush current in a fuse can be considered equal to 12 times the transformer full load current flowing for 1/10 of a second. Thus, when selecting the current rating for fuses used at the primary side of a transformer, the fuse minimum-melting curve must lie above and to the right of the point on the time-current curve corresponding to 12 times full load current and 0.1 second. The fuse whose minimum melting

curve lies just above and to the right of this point is the lowest rated fuse that can be used at the primary terminals to satisfy the inrush requirements. This criterion is often satisfied for all Eaton's fuses if the fuse current rating is equal to or greater than the transformer self-cooled full load current.

System operators frequently overload their transformers for short periods of time during normal and emergency situations. To allow this flexibility, it is necessary to select a fuse that can carry the overload without being deteriorating.

To accommodate these overloads, a fusing ratio higher than 1:1 is almost always required when applying fuses for transformer protection. The fuse emergency overload curve (**Page V14-T3-8**) and the required extent of overloading is used to determine the smallest fuse that can be applied. Determine the minimum fuse rating by using the duration (ordinate) of the transformer overload on the fuse overload curve (**Page V14-T3-8**) to obtain a the multiple of current rating that should not be exceeded. Divide the transformer overload current by the multiple obtained from the overload curve—the result is the minimum fuse current rating. Select the fuse with a continuous current rating that equals or is just larger than this value. The allowable time duration of the current in the primary side fuses during transformer overload should never exceed the values shown by the fuse overload curve on **Page V14-T3-8**.

Note: Short term and long term overloading of transformers will adversely affect the service life of the transformer. Also, increasing the primary fuse size to allow for higher overloads decreases the protection afforded the transformer. The extent to which transformers are overload, and the implications for system security are economic decisions that are taken by the system operator.

Suggested minimum fuse sizes for protection of self-cooled transformers are given in the table on **Page V14-T3-15**. These tables are based on the premise that the maximum 1.5 hour overload on the transformer would not exceed 200 percent of the transformer rating. This overload condition requires that the minimum ratio of fuse current rating to transformer full load current is 1.4:1. Fuse sizes listed in the table on **Page V14-T3-15** are those that are just higher than 1.4 times the transformer full load current. If higher or longer duration transformer overloads are to be permitted, a fuse with a higher continuous current rating may be required. The procedure described above should then be used to find the smallest permissible fuse size.

If provisions are made by thermal or other protective devices to limit transformer overloads to a lower range, the ratio of fuse current to transformer full load current can be less than 1.4:1. To find the amount of reduction permissible without damage to the fuse, the procedure using the overload curve should be used.

When the transformer has forced cooling, the minimum fuse size that can be applied that be based on the transformer top rating and the extent to which the transformer will be overloaded beyond the top rating.

It should be remembered that E-rated current limiting fuses applied at the primary terminals of a transformer might not provide protection for currents between one and two times the continuous current rating of the fuse. That is, for currents in this range that exceed the time limits shown by the fuse overload curve on **Page V14-T3-8** under the heading “Coordination”. Fuses subjected to such overloads may suffer from undetectable deterioration before the fusible element melts. In order to provide dependable overload protection for the transformer, protection must be applied on the secondary side of the transformer.

Equal concern should be given to the upper limit of continuous current rating that will provide protection for the transformer. The extent to which the fuses are to protect the transformer against secondary faults is one of several factors that determines the upper limit.

When a main secondary breaker is not used, the primary fuses may be the only devices that provide thru-fault protection for the transformer. In these circumstances the fuse should operate before the transformer windings are damaged due to the heavy currents. The capability of transformer windings to carry

these thru-fault or heavy currents varies from one transformer design to another. When specific information applicable to individual transformers is not available, the transformer heat curves given on **Page V14-T3-14** can be used to evaluate the thru-fault protection offered the transformer by the fuses. The curve labeled N=1 is drawn through the points defined in IEEE/ANSI Appendix C57.92, Section 92-06.200 such that the curve has the same shape as shown in Figure 1 of IEEE publication 273 titled, Guide for Protective Relay Application to Power Transformers. This curve applies to single-phase transformers and to three-phase faults on three phase transformer banks. Curves for values of N other than 1 apply to unsymmetrical faults on three-phase transformers and three-phase transformer banks that have at least one delta-connected winding. Ideally, the total clearing time-current of the primary fuse would lie below the heat curve for all values of current up to 25 times the transformer rated current. However, this is not usually possible as the fuse has minimum limitations placed on the rating due to long time overload impressed on the transformer and the fact that E-rated expulsion fuses do not provide protection for currents below two times their continuous current rating. In spite of these lower limitations, primary side fuses should protect the transformer for bolted secondary faults and higher impedance secondary faults to whatever extent is possible.













Wye connected transformers tied to the system neutral or floating have line currents that are equal to the winding currents for faults external to the transformer, regardless of whether the neutral is or is not grounded. Thus a fuse connected to the terminal of a wye-connected winding will see the same current that is in the winding for all faults external to the transformer. Also, there is a simple relation between the primary and secondary amperes, whether load or fault currents are being considered.

This is not the case when the transformer has a delta-connected winding, either on the primary or secondary side of the transformer. With delta-connected primary windings, the current in the lines (fuses) supplying the delta winding and currents in the primary delta windings generally are not equal, and of greater importance the ratio of line (fuse) current to winding current varies with the type of fault on the external system. With delta connected secondary windings, the current in the transformer secondary windings is generally not equal to the secondary line current, and the ratio of primary line current to the secondary line current varies with the type of fault on the secondary system.

The relationship between rated line (fuse) current and rated winding current (referred to, as the “base current of the winding” in IEEE/ANSI Std. C57™.12.00 is 1 for wye connected primaries and is $1/\sqrt{3}$ for delta-connected primaries. IEEE/ANSI Std. C57™.12.00 also indicates that the transformer winding shall be capable of withstanding 25 times rating winding current for two seconds and smaller multiples of rated winding current for longer periods of time. However, transformer overloads and faults are generally expressed in terms of line and not winding current. This could present a problem for fault conditions where the type of fault changes the relationship between the line and winding current (see the table below) gives a multiplier that will translate the line current in multiples of the winding current for different type faults for various transformer windings. This table leads us back to the transformer heat curves shown on **Page V14-T3-14** where it can be verified that the curve $N=1$ passes through the point 25 times full load line current and two seconds. The curves for other than $N=1$ are for unsymmetrical faults as can be seen from the table below.

Coordination diagrams employ the transformer heat curves and fuse time-current curves to determine which fuse rating may be safely applied. These diagrams are the tools used to apply the information previously cited. The most straight-forward diagram involves fuses applied at the terminals of transformers with wye primary windings. The table below shows that the fuse current is the same as the winding current for all faults external to the transformer. This means the coordination diagram consists simply of the direct reading of the fuse time-current curves and the transformer heat curve $N=1$ for coordination diagrams where the abscissa is labeled in amperes in the primary system. To coordinate with the abscissa labeled in secondary amperes, the same two curves are shifted to allow for the ratio between primary and secondary amperes.

Multiples of Primary Line Current for Fixed Secondary Winding Current

Transformer Connection All Neutrals Grounded		N (N Times Secondary Winding Current Gives Multiples of Primary Line Current)		
Primary	Secondary	Three-Phase Fault	Phase-to-Ground Fault	Phase-to-Phase Fault
		1		
		1	... 	1
		1	$1/\sqrt{3}$	
		—	...	$\sqrt{3}/2$

3.3

Current Limiting Fuses

Applications

3

When fuses are employed at the terminals of a delta-wye transformer, the coordination diagram becomes a bit more involved. In this instance the table on **Page V14-T3-13** shows that the fuse current varies in relation to the winding current depending on the nature of the fault. Thus, when the coordination is with respect to primary amperes, the diagram consists of one direct reading fuse time-current curve and one or more transformer heat curves. The number of heat curves included would be determined by the types of secondary faults considered. The table on **Page V14-T3-13** gives the N curve to be used for the different faults to be considered. When the coordination is with respect to secondary amperes, the diagram consists of one transformer heating curve (N=1) and up to three fuse time-current curves. The three time-current curves are again dependent on the possible faults to be considered. The table on **Page V14-T3-13** shows that after the curve is translated to secondary amperes it must be shifted one over the square root of 3 when phase-to-earth faults are considered and two over the square root of 3 when phase-to-phase faults are considered to obtain proper coordination.

Regardless of whether a primary or secondary current abscissa is employed, a coordination diagram for a delta-wye transformer shows that the primary side fuses do not protect the transformer for high-impedance secondary faults and overloads. This type of protection can be obtained through the application of secondary side breakers. If a secondary breaker were used it would be added to the coordination diagram by plotting the breaker phase and ground trip characteristics. Selective coordination would exist if the breaker phase trip characteristic curve lies below the fuse characteristic for a phase-to-phase fault and the heating curve, and the breaker ground trip characteristic for a single line-to-ground fault and the heating curve.

The proceeding pertains to diagrams using secondary amperes. If the breaker characteristic is to be translated to primary amperes, its characteristics must lie beneath the fuse characteristic and the heating curve for N=1. For unsymmetrical faults, the breaker characteristic shifts by the same multiple as the heating curve.

If further secondary protection is translated to the primary, the characteristic must lie beneath the secondary breaker characteristic for the different types of faults considered.

Fuses used at the terminals of a delta-delta transformer require:

1. Fuse time-current.
2. Heating curves if both three-phase and phase-to-phase faults are to be considered.

This agrees with information presented in the table on **Page V14-T3-13**. When the abscissa is in primary amperes, the curves are read directly. An abscissa in secondary amperes uses the same curves but shifts them from primary to secondary amperes.

For all the coordination diagrams just discussed, the vertical distance between the total clearing curve and the safe heat curve indicates the margin of protection offered for different types of faults. It should be remembered, however, that the transformer heat curves illustrated in this application data are drawn from the reference previously cited and they may not apply to all transformer designs.

Typical Transformer Heat Curves

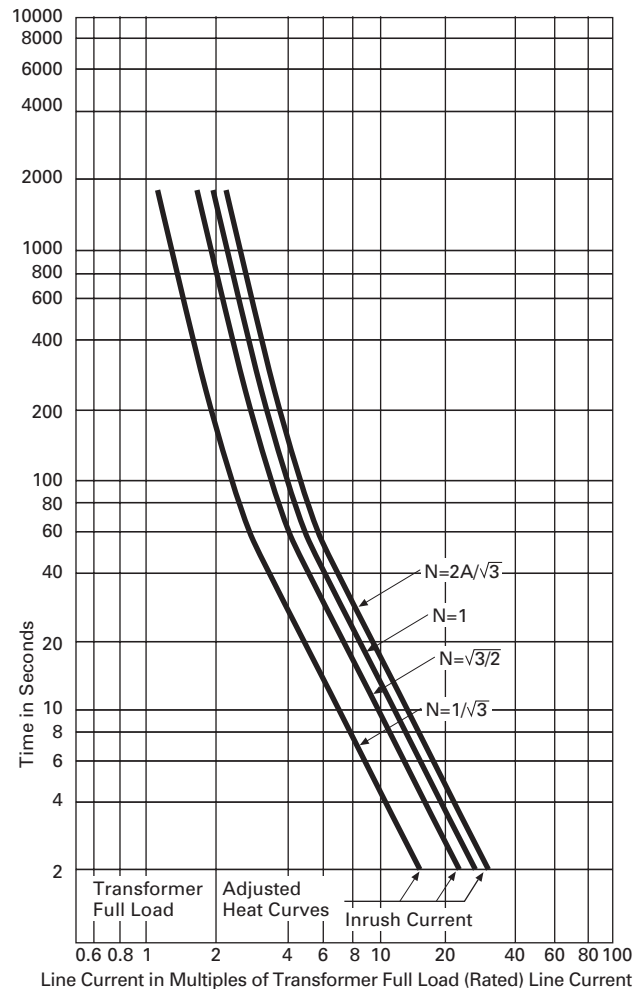

Suggested Minimum Current Limiting Fuse Current Ratings

Self-Cooled 2.4–15.5 kV Power Transformer Applications

System Nominal kV	2.4		4.16		4.8		7.2		12.0		13.2		13.8		14.4	
Fuse Maximum kV	2.75		5.5		5.5		8.3		15.5		15.5		15.5		15.5	
Transformer kVA Rating Self-Cooled	Full Load Current Amps	Fuse Rating Amps E or C	Full Load Current Amps	Fuse Rating Amps E or C	Full Load Current Amps	Fuse Rating Amps E or C	Full Load Current Amps	Fuse Rating Amps E or C	Full Load Current Amps	Fuse Rating Amps E or C	Full Load Current Amps	Fuse Rating Amps E or C	Full Load Current Amps	Fuse Rating Amps E or C	Full Load Current Amps	Fuse Rating Amps E or C
Three-Phase Transformers																
9	2.2	5E	1.3	3E	1.1	3E	0.7	3E/3.5C	0.4	1E	0.4	1E	0.4	1E	0.4	1E
15	3.6	15E	2.1	3E	1.8	3E	1.2	3E/3.5C	0.7	1E	0.7	1E	0.6	1E	0.6	1E
30	7.2	15E	4.2	10	3.6	5E	2.4	4.5C/5E	1.4	3E/4C	1.3	3E/4C	1.3	1E/4C	1.2	3E/4C
45	10.8	15E/18C	6.2	10	5.4	10	3.6	5E/6C	2.2	4C/5E	2	3C/5E	1.9	3E/4E	1.8	3E/4E
75	18	25	10.4	15	9	15E/18C	6	10	3.6	6C/10E	3.3	5E/6C	3.1	5E/6C	3	5E/6C
112.5	27	40E/45C	15.6	25	13.6	20	9	15	5.4	8C/10E	5	8C/10E	4.7	8C/10E	4.5	8C/10E
150	36	50	20.8	30	18	25	12	18C/20E	7.2	10	6.6	10	6.2	10	6	10
225	54	75C/80E	31.3	45C/50E	27.2	40	18	25	10.8	15	9.9	15	9.4	15	9	15
300	72	100	41.6	60C/65E	36	50	24	35C/40E	14.4	25	13.1	20	12.5	18C/20E	12	18C/20E
500	120	200E	69.4	100	60	100E	40	60C/65E	24.1	40	21.9	30	21	30	20	30
750	180	250E	104	150E	90	125E	60	100	36.1	60C/65E	32.8	45C/50E	31	45C/50E	30.1	45C/50E
1000	241	350E	140	200E	120	200E	80	125	48.1	75C/80E	43.7	60C/55E	42	60C/65E	40.1	60C/65E
1500	360	600E	208	300E	180	250E	120	200	72.2	100	65.6	100	62	100	60.1	100
2000	481	750E	278	400E	241	350E	160	250	96.2	150	87.5	125E/150C	84	125E/150C	80.2	125E/150C
2500	600	1100E	346	600E	301	450E	200	350E	120	200E	109	175	104	175	100	175
Single-Phase Transformers																
5	2.1	5E	1.2	3E	1	1.5E	0.7	3E/3.5C	0.4	1E	0.4	1E	0.4	1E	0.4	1E
10	4.2	15E	2.4	5E	2.1	3E	1.4	3E/3.5C	0.8	1.5E	0.8	1.5E	0.7	1E	0.7	1E
15	6.3	15E	3.6	5E	3.1	5E	2.1	3E/3.5C	1.3	3E/4C	1.1	3E/4C	1.1	3E/4C	1.1	3E/4C
25	10.4	15E	6	10	5.2	10	3.5	5E/6C	2.1	3E/4C	1.9	3E/4C	1.8	3E/4C	1.7	3E/4C
37.5	15.6	25	9	15E/18C	7.8	12C/15E	5.2	8C/10E	3.1	5E/6C	2.8	4C/5E	2.7	4C/5E	2.6	4C/5E
50	20.8	30E/35D	12	20	10.4	15	7	10	4.2	8C/10E	3.8	8C/10E	3.6	8C/10E	3.5	5E/6C
75	31.3	45C/50E	18	25	15.6	25	10.4	15	6.3	10	5.7	8C/10E	5.4	8C/10E	5.2	8C/10E
100	41.7	60C/65E	24	40	20.8	30	13.9	20	8.3	12C/15E	7.6	12C/15E	7.2	12C/15E	6.9	10
167	70	100	40	50	35	50	23.2	40	13.9	20	12.7	18C/20E	12.1	18C/20E	11.6	18C/20E
250	104	150E	60	100E	52.1	80E	34.8	50E/60C	20.8	30	19	30	18.1	30	17.4	30
333	139	200E	80	125E	69.5	100E	46.3	65E/100C	27.7	40	25.2	40	24.1	40	23.1	40
500	208	300E	120	200E	104	150E	39.6	100	41.6	60	38	60C/65E	36.2	60C/65E	34.7	60C/65E
667	278	400E	160	250E	139	200E	92.6	150	55.4	85C/100E	50.5	75C/80E	48.2	75C/80E	46.3	75C/80E
883	347	600E	200	350E	173	250E	115.5	200	69.4	100	63.5	100	60.4	85C/100E	57.8	85C/100E
1250	521	750E	300	450E	260	400E	174	250	104	175	95	150	90.6	150	86.8	125E/150C

Potential and Control Transformer Application

CLPT (CLE-PT) and (N)CLPT type fuses provide protection for the systems to which potential and control power transformers are connected. Like other fuses, (N)CLPT fuses must meet all of the basic selection requirements but there are a couple of differences in the application that will be mentioned here.

Instrument potential transformer fuses are selected on the basis of the transformer magnetizing inrush current instead of the full load current rating. To prevent unnecessary fuse operation, the fuses must have sufficient inrush capacity to safely pass the magnetizing current inrush of the transformer. Fuses should be selected on the basis of the smallest current rating whose minimum melting time-current relationship lies above and to the right of the inrush value.

In some applications these types of transformers are operated in a wye connection at 0.557 times their normal rated voltage. (N)CLPT fuses will usually protect the transformer when applied at this reduced voltage but if the short circuit is through long leads or if the primary voltage is materially decreased by the short circuit on the secondary, the short-circuit current may not be sufficient to operate the fuses.

Motor Protection

Medium voltage motor starters are used to protect medium voltage motor circuits. These starters use overload relays, contactors and back-up current-limiting fuses to provide complete overcurrent protection. The fuses operate to interrupt high values of fault current that exceed the interrupting rating of the contactor and the overload relay operates to open the contactor before the fuse operates for lesser, yet abnormal, currents due to motor overloads, locked rotor, repeated starts, extended accelerating time or low value fault currents. To obtain this coordination, the proper combination of fuse, contactor, current transformer and overload relay must be used to ensure that the contactor operates within its ratings and the fuse for those values of fault current that exceed the contactor's rating. Responsibility for this coordination rests with the manufacturer of the motor starter. In choosing suitable components, the following four areas of protection must be considered:

1. Protection of the motor against sustained overloads and locked rotor conditions by means of the overload relays and contactor;
2. Protection of the fuses against sustained currents above the fuse continuous current ratings and yet below their minimum interrupting value by means of overload relays and contactor;
3. Protection of the circuit by means of the overload relays and contactor for currents within the interrupting limits of the contactor where it is more economic for the contactor to operate rather than the fuses; and
4. Protection of the circuit, contactor, overload relays and current transformers from damaging effects of maximum fault currents by means of properly sized back-up current-limiting fuses that restrict the let-through currents on high current faults to tolerable levels.

The fuses are not protecting the motor itself; they are protecting the system from faults in the motor and motor control circuit.

When selecting a fuse for such a coordinated motor starter scheme, the basic requirements for the fuse in addition to those of adequate voltage and interrupting rating are:

1. The fuse continuous current rating must be equal to or greater than the full load current of the motor;
2. The fuse must have the capacity to carry continuously, without damage, currents less than the pick-up value of the overload relay, but no less than 125% of the motor full load current; and

3. The fuse must have the capacity to carry, without damage, currents greater than the pick-up value of the overload relay but less than the fuse melt and relay overload setting curves for sufficient time to allow the overload relay to operate.
4. The fuse must be selected to allow for the run-up time of the motor, and also for the frequency of starts. It is typical also to select fuses to allow for two consecutive starts.

This is the reason for emphasizing the need to avoid damage to the fuse from long duration overloads such as those caused by locked rotor conditions. Damage can generally be avoided by keeping the melting curve of the fuse above the locked rotor current by a safe margin until it is intersected by the relay curve. A reasonable margin is 10% but the manufacturer's application instructions will state just how close an application is permissible.

Typical Fuse and Motor Starter Coordination

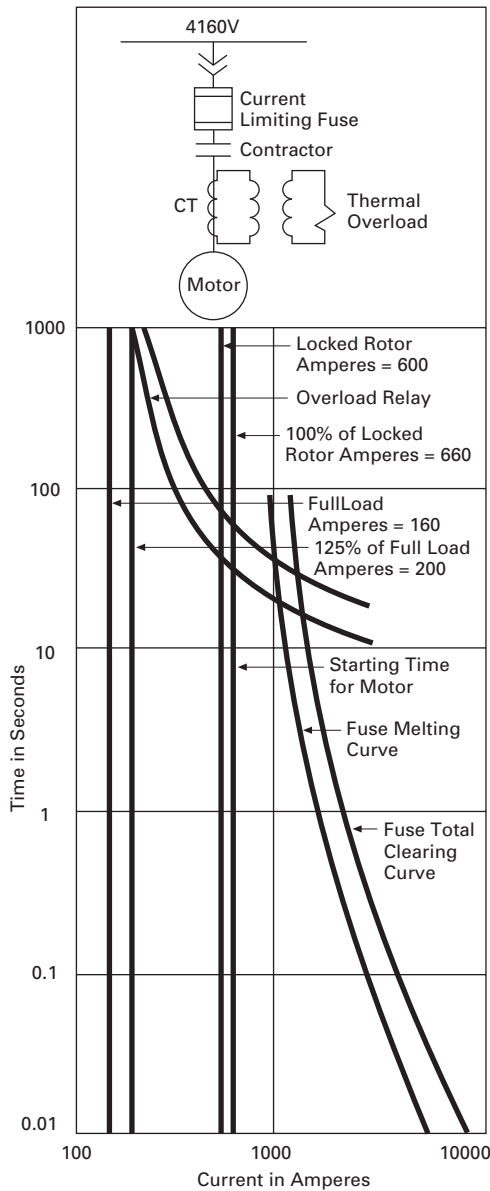

Although it is possible to protect a medium voltage motor circuit with a general-purpose or full-range fuse without a series relay-contactor combination, it is not a common practice for two reasons. First, the melting current of the fuse is approximately twice its rated current. This means that the fuse does not provide protection against anything less than 100% overload, and usually this range is even larger. Second, the damage characteristics of the apparatus and the total clearing time-

current characteristic of the fuse hardly ever coincide. Thus a motor protected only by a general-purpose or full-range fuse may be exposed to overloads of somewhat longer duration than desirable or the fuse may limit the equipment's overload capacity.

As should be obvious, the duty of fuses in motor starter circuits is characterized by the frequent application of high overloads such as motor starting currents and cooling periods while the motor is off. Eaton's CLS fuse has been thoroughly tested to

ensure the fuse is capable of withstanding these frequent and severe heating and cooling cycles. The test consisted of running 2000A through a 24R fuse for 10 seconds, then 400A for 5 minutes and finally cooling the fuse with no current for 5 minutes. This three-step cycle was repeated 3000 times with the fuse showing no deterioration as measured by change in resistance at the conclusion.

To aid in selecting a fuse for motor starter application, the following may prove helpful:

$$\text{Full load current} = \frac{(\text{horsepower}) \cdot (746)}{[(\text{voltage}) \cdot (3 \cdot 5) \cdot (\text{efficiency}) \cdot (\text{PF})]}$$

For general use, a 0.9 for efficiency and a 0.8 for power factor yield the following simple relationship between full load current and horsepower:

$$\text{Full load current} = \frac{(\text{horsepower}) \cdot (0.701)}{(kV)}$$

Again on a general basis, inrush current may be assumed to be six times the full load current for a duration of 15 seconds.

Repetitive Faults

It is often desired to determine the performance of fuses under repetitive faults such as produced by the operation of reclosing circuit breakers. This performance is becoming of increasing interest as a result of the increased application of current limiting fuses on pole type transformers. The performance is determined by graphically simulating the fuse's heating and cooling characteristics that are found in and expressed by the melting time-current curves.

Conventional E- and C-rated fuses can with good approximation be regarded as bodies whose heating and cooling properties are described by the basic exponential Curves A and B as shown in **Page V14-T3-18**. Except for being inverted, the cooling curve is the same as the heating curve as both have

the same time constant. Each fuse has a specific time constant that can be calculated with sufficient accuracy by the formula $t = 0.1 S^2$ where S is the melting current at 0.1 second divided by the melting current at 300,600 or 1000 seconds. The 300 seconds applies for fuses rated 100E amperes or less, the 600 seconds for fuses rated above 100E amperes, and the 1000 seconds for C-rated fuses.

The time constant of a specific fuse, having been obtained in terms of seconds, gives a specific time scale to the general heating and cooling curves of **Page V14-T3-18**. It enables plotting the course of the fuse temperature (in percent values) if the sequence and duration of the open and closed periods of the recloser are known. This is illustrated by curve C that is formed by piecing together the proper sections of Curves A and B.

Next the temperature at which the fuse will melt must be determined. Refer to the standard time-current curves and find the melting time M for a specific value of fault current. The melting temperature T_m lies where the ordinate to the time M intersects curve A. It is not necessary to know the absolute value of this temperature as it is sufficient to know its relation to the peaks. A similar temperature T_n can be found using the total clearing time for the specific fault current. The results are two temperatures where any time the fuse curve C intersects line T_m the fuse could operate and any time it intersects line T_n the fuse will definitely operate. The gap between T_m and T_n indicates the tolerance range as set forth in ANSI and NEMA standards where E- and C-rated fuses are defined.

Temperature Cycle of a Fuse During Reclosing Operation

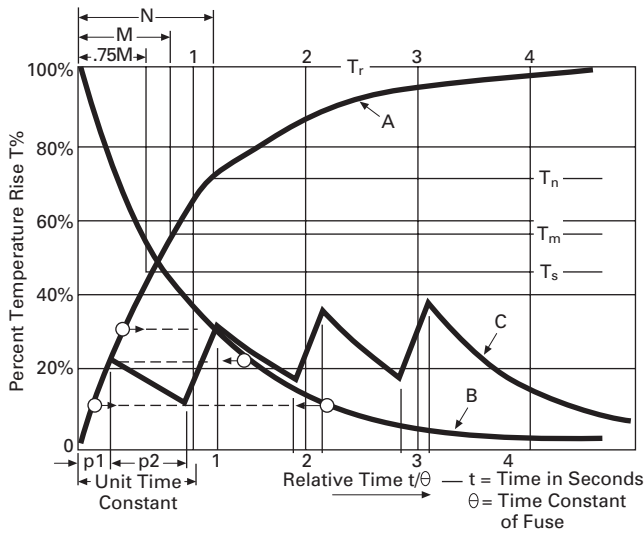

Curve A—Basic fuse heating curve: $T_f (1 - e^{-t/\theta})$
 Curve B—Basic fuse cooling curve: $T_f \times e^{-t/\theta}$
 Curve C—Temperature rise curve of fuse subjected to reclosing cycle
 M—Melting time of fuse at a given fault current
 N—Total clearing time of fuse at same fault current
 T_m, T_n —Levels of melting temperature of fastest and of slowest fuse (See note below)
 T_s —Safe temperature level, considering service variables
 T_r —Hypothetical steady-state temperature level (100%) attained if the fuse element did not open when melting temperature was reached but continued to be a resistance of constant value

Note: The absolute temperature at which the elements of the fastest and of the slowest fuse melt is the same since both fuses are made of the same material. However, T_n and T_m are different if measured by the final temperature level if reached at a given current.

Reclosing Circuit Breaker Fuse Coordination

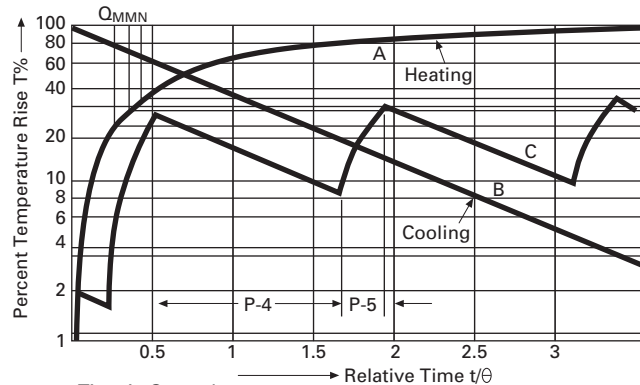

t = Time in Seconds
 θ = Time Constant of Fuse

Notes: Recloser data: 400PR (cycling code A1-3CH3).
 Fuse type and rating: CLT (drawout) 8.3 kV 150°C.
 Fuse speed ration, S-2150/420 = 5.11.
 Thermal time constant, $\theta = 0.10 S^2$, 2.61 seconds.
 Fault current 1350A.

If the fuse is not to operate, curve C must remain below the level T_m by a safe margin. It is common practice to provide such a safety margin by coordinating the breaker with a fuse curve whose time ordinates are 75 percent of those of the melting curve. Line T_s represents this temperature as shown.

Although the construction of the temperature diagram as outlined above basically offers no difficulties, the manipulation is made easier and more accurate by putting the graph on semi-logarithmic coordinates as shown. On these coordinates, the cooling curve B becomes a straight line.

E-Rated Power Fuses



Contents

<i>Description</i>	<i>Page</i>
CLE, HLE, LHLE, AHLE, BHLE, HCL and BHCL Type Fuses	
Catalog Number Selection	V14-T3-21
Ratings and Selection	V14-T3-21
Product Selection	V14-T3-24
CLE Type	V14-T3-24
HLE Type	V14-T3-28
LHLE Type	V14-T3-31
AHLE Type	V14-T3-32
BHLE Type	V14-T3-33
HCL Type	V14-T3-36
Mounting Details	V14-T3-38

CLE, HLE, LHLE, AHLE, BHLE, HCL and BHCL Type Fuses

Product Description

Eaton offers a wide range of interrupting ratings in single barrel designs with ratings extended to higher currents in double, triple and quad barrel designs. E-rated fuses are available in both long (CLE), intermediate (LHLE) and short (HLE) clip center designs.

CLE fuses conform to dimensional standards established in the past by Westinghouse when the original BAL current limiting power fuses for transformer and general feeder applications were introduced.

HLE fuses conform to later, shorter dimensional standards.

BHLE fuses are identical to HLE fuses with the addition of "bolt-in" mounting blades.

HCL fuses are special dimension fuses for "bolt-in" and "clip-lock" mounting blades.

Applications

Helix type (helical element configuration, current limiting) and Heritage CLE type medium voltage fuses are general purpose, indoor fuses designed to provide both high and low level fault protection. Helix fuses may be applied wherever it is necessary to limit short-circuit currents on high capacity systems.

Because of their general purpose, current limiting characteristics, these types of fuses are well suited for a wide variety of distribution systems and consumer applications. Some of the more frequent possibilities are:

- Power transformer protection
- Fused switches
- Feeder circuit sectionalization

Features

Helix Type Fuses

Helix type current limiting fuses, designed for indoor and outdoor applications, are replaceable fuse units with automatic blown fuse indication provided by a striker pin. In addition to giving local indication of fuse condition, the striker pin can be used to trigger an external tripping device. The powerful striker pin delivers approximately three joules of energy over a 5/8-inch travel distance, more than sufficient for mechanical operation of trip-all-phase devices or micro-switches. HLE and CLE type fuses can be mounted in disconnect or non-disconnect mounting configurations. BHLE type fuses can be directly "bolted-in" onto switchgear bus bars. HCL type fuse units are mounted in cam action clip-lock clips for easy installation and replacement.

Helix fuses have a semi-coreless design, enclosed in high strength, filament wound glass and epoxy tubes. They are filled with high purity silica sand of controlled grain size. Fuse elements are pure silver in a double helix configuration to optimize performance by maximizing the number of elements.

The double helix design delivers:

- Higher current ratings
- Cooler operation
- Improved time-current characteristics
- Reduced 12t let-through
- Shorter length

Single, double and triple barrel designs are available to cover a wide range of current, voltage and interrupting ratings. For their sizes, Eaton's helix type fuses offer the highest available E-ratings.

In addition, Eaton's 3-inch diameter fuses will directly replace other manufacturer's fuses.

Heritage Type Fuses

Certain “Heritage” Westinghouse fuse types have been retained where there are no suitable helix type fuses to replace them. These fuses are normally only supplied for replacement purposes. The major items here are the shorter 2-inch diameter 2.75 kV CLE fuses from 15E to 25E and 15.5 kV fuses where the older designs used more parallel barrels than the current Helix design.

The Heritage fuse designs are suitable for indoor use only.

CLE and HLE Features

Helix type current limiting fuses offer a number of advantages over competing current limiting designs. During the selection process, consider the following:

- **Optimized Energy Exchange:** The double concentric helix configuration (inner and outer) optimizes energy exchange by making more efficient use of the sand filler
 - **Improved Arc Control:** The double helix design has more elements for more surface area permitting better arc control
 - **Lower Temperature Rise:** Heat radiation with the HLE design is excellent resulting in lower normal operating temperatures
 - **Promotes Faster Melting:** Under overload conditions, thermal transfer from the inner helix is reduced by a modified temperature gradient leading to faster melting
 - **Blown Fuse Indication:** Blown fuse striker pin will protrude from the top of the fuse providing a visual indication of operation, as well as a triggering means for external devices
 - **Interchangeability:** Helix type fuses are mechanically interchangeable and in many cases have higher maximum current ratings than competing current limiting fuses
 - **Limited Arc Voltage:** Improved limited arc voltage on 40E and higher current rating fuses permits 15.5 kV fuses to be used on 8.3 kV circuits and 8.3 kV fuses to be used on 5.5 kV circuits
- Helix type current limiting fuses also offer additional advantages over other types of fuse designs:
- **Quiet and Safe Operation:** Helix type fuses are sealed static units eliminating the need for externally mounted exhaust control devices
 - **Limits Fault Current:** By design, helix type fuses interrupt high fault currents before the first loop of fault current reaches its natural crest value. The double helix design delivers lower I^2t
 - **Higher Interrupting Capabilities:** Helix type fuses have higher interrupting ratings than expulsion fuses because of their current limiting capabilities
 - **Indoor/Outdoor Application:** Helix type fuse end caps are magneformed to the tube and sealed with resilient RTV sealant

Mounting Hardware

- CLE type and HLE helix type current limiting fuses are designed to be used in either disconnect or non-disconnect mountings
- All CLE and HLE fuse units can be mounted, as supplied, in appropriate non-disconnect mountings. Adding disconnect fuse end fittings to a CLE or HLE fuse unit permits it to be mounted in an appropriate disconnect mounting
- Most HCL current limiting fuse units have blades to enable the fuse to be mounted in cam locking clips
- HCL5-900E and 750E, and BHLE fuses have end blades for direct bolting to custom bus bars or mountings
- AHLE and certain Heritage designs are specifically equipped for mounting in Eaton’s Ampgard motor starter equipment
- Disconnect and non-disconnect live parts above the insulator are available for CLE, HLE and HCL clip-lock fuses

Catalog Number Selection

Helix Fuse Units

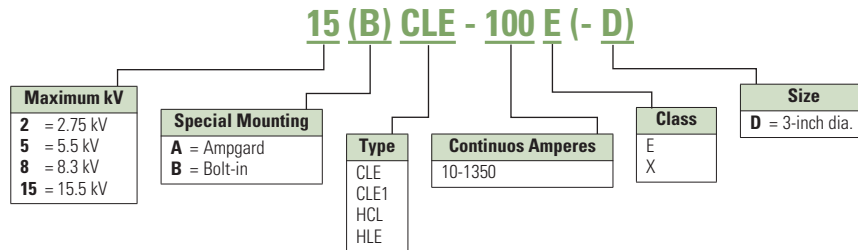

Helix Fuse Mounting

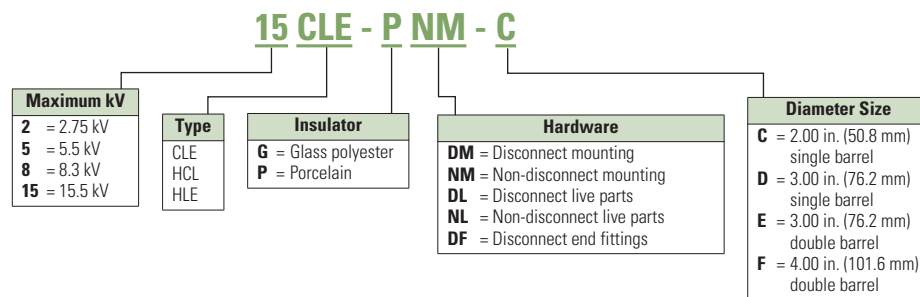

Ratings and Selection

When a decision has been made to use current limiting fuses, the minimum amount of information required to make the proper selection is:

- Voltage rating
- Current rating
- Interrupting rating
- Mounting method:
 - Non-disconnect mounting
 - Disconnect mounting
 - Clip-lock mounting
 - Direct bolt-in mounting
 - Live parts only
 - No required mounting

Refer to tables on **Pages V14-T3-22 to V14-T3-41** for assistance in selecting the correct fuse catalog number.

These types of fuses commonly provide protection for transformer primaries. There are specific rules governing the selection of the required fuse continuous rating. The current limiting fuse application notes earlier in this publication offer suggested minimum current limiting fuse current ratings for self-cooled transformers. The suggested ratings are intended as general guidelines only.

When selecting the appropriate fuse for a new installation, keep in mind that one fuse unit and one compatible mounting is required for each phase.

3.4

Current Limiting Fuses

CLE, HLE, LHLE, AHLE, BHLE, HCL and BHCL Type Fuses

Suggested Minimum Current Limiting Fuse Current Ratings for Self-Cooled 2.4–15.5 kV Transformer Applications—E-Rated Fuses

System Nominal kV	2.4		4.16		4.8		7.2		12.0		13.2		13.8		14.4	
	Fuse Maximum kV	2.75	5.5	5.5	8.3	15.5	15.5	15.5	15.5	15.5	15.5	15.5	15.5	15.5	15.5	15.5
Transformer kVA Rating Self-Cooled	Full Load Current Amps	Fuse Rating Amps E	Full Load Current Amps	Fuse Rating Amps E	Full Load Current Amps	Fuse Rating Amps E	Full Load Current Amps	Fuse Rating Amps E	Full Load Current Amps	Fuse Rating Amps E	Full Load Current Amps	Fuse Rating Amps E	Full Load Current Amps	Fuse Rating Amps E	Full Load Current Amps	Fuse Rating Amps E
Three-Phase Transformer																
9	2.2	5E ^①	1.3	3E ^①	1.1	3E ^①	0.7	3E ^①	0.4	1E ^①	0.4	1E ^①	0.4	1E ^①	0.4	1E ^①
15	3.6	10E ^①	2.1	3E ^①	1.8	3E ^①	1.2	3E ^①	0.7	1.5E ^①	0.7	1E ^①	0.6	1E ^①	0.6	1E ^①
30	7.2	15E	4.2	10E	3.6	10E	2.4	5E ^①	1.4	3E ^①	1.3	3E ^①	1.3	3E ^①	1.2	3E ^①
45	10.8	20E	6.2	10E	5.4	10E	3.6	10E	2.2	5E ^①	2.0	3E ^①	1.9	3E ^①	1.8	3E ^①
75	18.0	30E	10.4	15E	9.0	15E	6.0	10E	3.6	10E	3.3	5E ^①	3.1	5E ^①	3.0	5E ^①
112.5	27.1	50E	15.6	25E	13.5	20E	9.0	15E	5.4	10E	4.9	10E	4.7	10E	4.5	10E
150	36.1	65E	20.8	30E	18.0	30E	12.0	20E	7.2	15E	6.6	10E	6.3	10E	6.0	10E
225	54.1	80E	31.2	50E	27.1	50E	18.0	30E	10.8	20E	9.8	15E	9.4	15E	9.0	15E
300	72.2	125E	41.6	80E	36.1	65E	24.1	40E	14.4	25E	13.1	20E	12.6	20E	12.0	20E
500	120.3	200E	69.4	125E	60.1	100E	40.1	65E	24.1	50E	21.9	40E	20.9	40E	20.0	40E
750	180.4	300E	104.1	150E	90.2	150E	60.1	100E	36.1	65E	32.8	65E	31.4	65E	30.1	65E
1000	240.6	350E	138.8	200E	120.3	175E	80.2	125E	48.1	80E	43.7	80E	41.8	80E	40.1	80E
1500	360.8	600E ^{②③}	208.2	300E	180.4	300E	120.3	175E	72.2	125E	65.6	100E	62.8	100E	60.1	100E
2000	481.1	750E ^{②③}	277.6	400E	240.6	350E	160.4	250E	96.2	150E	87.5	150E	83.7	150E	80.2	125E
2500	601.4	1100E ^{②③}	347.0	600E ^③	300.7	450E	200.5	300E	120.3	200E	109.3	175E	104.6	175E	100.2	175E
Single-Phase Transformer																
5	2.08	3E ^①	1.20	3E ^①	1.04	1.5E ^①	0.69	3E ^①	0.42	1E ^①	0.38	1E ^①	0.36	1E ^①	0.35	1E ^①
10	4.17	10E	2.40	5E ^①	2.08	3E ^①	1.39	3E ^①	0.83	1.5E ^①	0.76	1.5E ^①	0.72	1.5E ^①	0.69	1.5E ^①
15	6.25	10E	3.61	10E	3.13	5E ^①	2.08	3E ^①	1.25	3E ^①	1.14	3E ^①	1.09	3E ^①	1.04	3E ^①
25	10.42	15E	6.01	10E	5.21	10E	3.47	5Ev	2.08	5E ^①	1.89	3E ^①	1.81	3E ^①	1.74	3E ^①
37.5	15.63	25E	9.01	15E	7.81	15E	5.21	10E	3.13	5E	2.84	5E ^①	2.72	5E ^①	2.60	5E ^①
50	20.83	40E	12.02	20E	10.42	15E	6.94	10E	4.17	10E	3.79	10E	3.62	10E	3.47	10E
75	31.25	50E	18.03	30E	15.63	25E	10.42	15E	6.25	10E	5.68	10E	5.43	10E	5.21	10E
100	41.67	65E	24.04	50E	20.83	30E	13.89	20E	8.33	15E	7.58	15E	7.25	15E	6.94	15E
167	69.58	100E	40.14	80E	34.79	65E	23.19	40E	13.92	25E	12.65	20E	12.10	20E	11.60	20E
250	104.17	150E	60.10	125E	52.08	100E	34.72	65E	20.83	40E	18.94	30E	18.12	30E	17.36	30E
333	138.75	200E	80.05	150E	69.38	125E	46.25	80E	27.75	50E	25.23	50E	24.13	40E	23.13	40E
500	208.33	300E	120.19	175E	104.17	150E	69.44	125E	41.67	80E	37.88	65E	36.23	65E	34.72	65E
667	277.92	400E	160.34	250E	138.96	200E	92.64	150E	55.58	100E	50.53	80E	48.33	80E	46.32	80E
883	367.92	600E ^{②③}	212.26	300E	183.96	300E	122.64	175E	73.58	125E	66.89	125E	63.99	100E	61.32	100E
1250	520.83	750E ^{②③}	300.48	450E	260.42	400E	173.61	250E	104.17	175E	94.70	150E	90.58	150E	86.81	150E

Notes

- ① CLPT fuses.
- ② 5CLE fuses.
- ③ Not FM compliant for less flammable transformer liquids.

Eaton Helix Fuse I²t Values

Ampere Rating	Min. Melt	5.5 kV		8.3 kV		15.5 kV		Min. Melt	Max. Clear	
		CLE	HLE	CLE	HLE	CLE	HLE			
		63 kA		50 kA		63 kA				
		Max. Clear	Min. Melt	Max. Clear	Min. Melt	Max. Clear	Min. Melt	Max. Clear	Min. Melt	Max. Clear
10E	720	9000	9000	720	9000	9000	720	9000	720	9000
15E	1600	13,500	13,500	1600	13,500	13,500	1600	13,500	1600	13,500
20E	3000	20,000	20,000	3000	20,000	20,000	3000	20,000	3000	20,000
25E	4500	27,000	27,000	4500	27,000	27,000	4500	27,000	4500	27,000
30E	6500	36,000	36,000	6500	36,000	36,000	6500	36,000	6500	36,000
40E	1000	20,000	20,000	1000	20,000	20,000	1000	20,000	1000	20,000
50E	1500	40,000	40,000	1500	40,000	40,000	1500	40,000	1500	40,000
65E	2600	65,000	65,000	3000	65,000	65,000	2600	65,000	2600	65,000
80E	4300	120,000	120,000	5000	140,000	140,000	5000	140,000	5000	140,000
100E	6400	160,000	160,000	8500	225,000	225,000	8500	225,000	8500	225,000
125E	10,000	200,000	200,000	22,500	275,000	275,000	22,500	270,000	22,500	270,000
150E	36,000	230,000	245,000	30,000	325,000	325,000	42,000	450,000	—	—
175E	53,000	575,000	625,000	48,000	400,000	400,000	—	—	—	—
200E	74,000	600,000	630,000	—	—	—	—	—	—	—
250E	11,500	700,000	900,000	—	—	—	—	—	—	—
150E	—	—	—	—	—	—	—	—	20,000	450,000
175E	—	—	—	—	—	—	22,000	750,000	25,000	750,000
200E	—	—	—	25,000	900,000	900,000	35,000	900,000	34,000	900,000
250E	—	—	—	90,000	1,100,000	1,100,000	100,000	1,000,000	65,000	1,100,000
300E	18,500	1,600,000	1,700,000	145,000	1,300,000	1,300,000	170,000	1,700,000	—	—
350E	225,000	2,000,000	2,100,000	190,000	1,600,000	1,600,000	—	—	—	—
400E	300,000	2,300,000	2,500,000	—	—	—	—	—	—	—
450E	465,000	2,800,000	3,000,000	—	—	—	—	—	—	—

3.4

Current Limiting Fuses

CLE, HLE, LHLE, AHLE, BHLE, HCL and BHCL Type Fuses

Product Selection

CLE Type

3

CLE Type



CLE Type Current Limiting Fuses 2.75 kV Maximum (2.4 kV Nominal)

Current Rating (Amperes)	Barrel Number	Interrupting Rating rms (kA Sym.)	Heritage Product	Indoor/Outdoor	Performance Curves			Catalog Number
					Minimum Melting Time	Total Clearing Time	Peak Let-Through Current	
15E	1	50	H	Indoor	TC56353202	TC56353302	TC63931702	2CLE-15E
20E	1	50	H	Indoor	TC56353202	TC56353302	TC63931702	2CLE-20E
25E	1	50	H	Indoor	TC56353202	TC56353302	TC63931702	2CLE-25E
10E	1	50	H	Indoor	TC53686104	TC53686204	TC63931704	2CLE-10E
30E	1	50	H	Indoor	TC53686104	TC53686204	TC63931704	2CLE-30E
40E	1	50	H	Indoor	TC53686104	TC53686204	TC63931704	2CLE-40E
50E	1	50	H	Indoor	TC53686104	TC53686204	TC63931704	2CLE-50E
65E	1	50	H	Indoor	TC53686104	TC53686204	TC63931704	2CLE-65E
80E	1	50	H	Indoor	TC53686104	TC53686204	TC63931704	2CLE-80E
100E	1	50	H	Indoor	TC53686104	TC53686204	TC63931704	2CLE-100E
125E	1	50	H	Indoor	TC53686104	TC53686204	TC63931704	2CLE-125E
150E	1	50	H	Indoor	TC53686104	TC53686204	TC63931704	2CLE-150E
200E	1	50	H	Indoor	TC53686104	TC53686204	TC63931704	2CLE-200E
225E	1	50	H	Indoor	TC53686104	TC53686204	TC63931704	2CLE-225E
250E	2	50	H	Indoor	TC53690002	TC53690102	TC63931802	2CLE-250E
300E	2	50	H	Indoor	TC53690002	TC53690102	TC63931802	2CLE-300E
350X	2	50	H	Indoor	TC53690002	TC53690102	TC63931802	2CLE-350X
400X	2	50	H	Indoor	TC53690002	TC53690102	TC63931802	2CLE-400X
450X	2	50	H	Indoor	TC53690002	TC53690102	TC63931802	2CLE-450X

CLE Type Mountings and Hardware 2.75 kV Maximum (2.4 kV Nominal)

Ampere Rating	Fuse Mounting Type ①	Voltage BIL (kV)	Diameter	Clip Center	Length	Approximate Shipping Weight Lbs (kg)	Mounting (Including Live Parts, End Fittings) ②		Live Parts (Including End Fittings) ②	End Fittings (Disconnect Only)
							Porcelain Insulator Catalog Number	Glass-Polyester Insulator Catalog Number	Catalog Number	Catalog Number
15E–25E	Non-disconnect	60	2.00 (50.8)	8.13 (206.5)	9.50 (241.3)	2 (0.91)	2CLE-PNM-C	2CLE-GNM-C	CLE-NL-C	—
	Disconnect	60					2CLE-PDM-C	2CLE-GDM-C	CLE-DL-C	CLE-DF-C
10E–250E	Non-disconnect	60	3.00 (76.2)	7.00 (177.8)	10.90 (276.9)	7 (3.18)	2CLE-PNM-D	2CLE-GNM-D	CLE-NL-D	—
	Disconnect	60					2CLE-PDM-D	2CLE-GDM-D	CLE-DL-D	CLE-DF-D
300E–450E	Non-disconnect	60	3.00 (76.2)	7.00 (177.8)	10.90 (276.9)	15 (6.81)	2CLE-PNM-E	2CLE-GNM-E	CLE-NL-E	—
	Disconnect	60					2CLE-PDM-E	2CLE-GDM-E	CLE-DL-E	CLE-DF-E

Fuse Dimensional Details

Approximate Dimensions in Inches (mm)

CLE Type Fuse

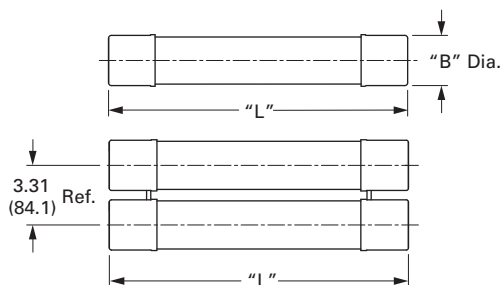

CLE kV	"L"	"B" Dia.
15E–25E	9.50 (241.3)	2.00 (50.8)
10E–450E	10.90 (276.9)	3.00 (76.2)

Notes

- ① See Page V14-T3-38 for diagram of typical mounting.
- ② End fittings supplied only when required.

CLE Type

CLE Type Current Limiting Fuses 5.5 kV Maximum (4.8 kV Nominal)



Current Rating (Amperes)	Barrel Number	Interrupting Rating rms (kA Sym.)	Heritage Product	Indoor/Outdoor	Performance Curves			Catalog Number
					Minimum Melting Time	Total Clearing Time	Peak Let-Through Current	
15E	1	50	H	Indoor	TC56353204	TC56353304	TC63931702	5CLE-15E
20E	1	50	H	Indoor	TC56353204	TC56353304	TC63931702	5CLE-20E
25E	1	50	H	Indoor	TC56353204	TC56353304	TC63931702	5CLE-25E
10E	1	63	—	Indoor/outdoor	TC70548501	TC70548601	TC70548701	5CLE-10E-D
15E	1	63	—	Indoor/outdoor	TC70548501	TC70548601	TC70548701	5CLE-15E-D
20E	1	63	—	Indoor/outdoor	TC70548501	TC70548601	TC70548701	5CLE-20E-D
25E	1	63	—	Indoor/outdoor	TC70548501	TC70548601	TC70548701	5CLE-25E-D
30E	1	63	—	Indoor/outdoor	TC70548501	TC70548601	TC70548701	5CLE-30E
40E	1	50	—	Indoor/outdoor	TC70545801	TC70545901	TC70546701	5CLE-40E
50E	1	50	—	Indoor/outdoor	TC70545801	TC70545901	TC70546701	5CLE-50E
65E	1	50	—	Indoor/outdoor	TC70545801	TC70545901	TC70546701	5CLE-65E
80E	1	50	—	Indoor/outdoor	TC70545801	TC70545901	TC70546701	5CLE-80E
100E	1	50	—	Indoor/outdoor	TC70545801	TC70545901	TC70546701	5CLE-100E
125E	1	50	—	Indoor/outdoor	TC70545801	TC70545901	TC70546701	5CLE-125E
150E	1	63	—	Indoor/outdoor	TC70545801	TC70545901	TC70547601	5CLE-150E
175E	1	63	—	Indoor/outdoor	TC70545801	TC70545901	TC70547601	5CLE-175E
200E	1	63	—	Indoor/outdoor	TC70545801	TC70545901	TC70547601	5CLE-200E
250E	1	63	—	Indoor/outdoor	TC70545801	TC70545901	TC70547601	5CLE-250E
300E	2	63	—	Indoor/outdoor	TC70546001	TC70546101	TC70547601	5CLE-300E
350E	2	63	—	Indoor/outdoor	TC70546001	TC70546101	TC70547601	5CLE-350E
400E	2	63	—	Indoor/outdoor	TC70546001	TC70546101	TC70547601	5CLE-400E
450E	2	63	—	Indoor/outdoor	TC70546001	TC70546101	TC70547601	5CLE-450E
600E	2	40	—	Indoor	TC62908902	TC62908903	TC62908904	5CLE-600E
750E	2	40	—	Indoor	TC62908902	TC62908903	TC62908904	5CLE-750E
1100E	4	31	—	Indoor	TC62908902	TC62908903	TC62908904	5CLE-1100E
1350E	4	31	—	Indoor	TC62908902	TC62908903	TC62908904	5CLE-1350E

CLE Type Mountings and Hardware 5.5 kV Maximum (4.8 kV Nominal)

Ampere Rating	Fuse Mounting Type ①	Voltage BIL (kV)	Diameter Approx. Dimensions in Inches (mm)	Clip Center	Length	Approximate Shipping Weight Lbs (kg)	Mounting (Including Live Parts, End Fittings) ②		Live Parts (Including End Fittings) ②	End Fittings (Disconnect Only)
							Porcelain Insulator Catalog Number	Glass-Polyester Insulator Catalog Number		
10E-D–25E-D	Non-disconnect	60	3.00 (76.2)	14.00 (355.6)	17.90 (454.7)	9 (4.09)	5CLE-PNM-D	5CLE-GNM-D	CLE-NL-D	—
30E–250E	Disconnect	60	—	—	—	—	5CLE-PDM-D	5CLE-GDM-D	CLE-DL-D	CLE-DF-D
15E–25E	Non-disconnect	60	2.00 (50.8)	11.50 (292.1)	12.90 (327.7)	3 (1.36)	5CLE-PNM-C	5CLE-GNM-C	CLE-NL-C	—
	Disconnect	60	—	—	—	—	5CLE-PDM-C	5CLE-GDM-C	CLE-DL-C	CLE-DF-C
300E–450E	Non-disconnect	60	3.00 (76.2)	14.00 (355.6)	17.90 (454.7)	19 (8.63)	5CLE-PNM-E	5CLE-GNM-E	CLE-NL-E	—
	Disconnect	60	—	—	—	—	5CLE-PDM-E	5CLE-GDM-E	CLE-DL-E	CLE-DF-E
600E and 750E	Consult factory	60	4.00 (101.6)	N/A	N/A	40 (18.16)	—	—	—	—
1100E and 1350E	Consult factory	—	4.00 (101.6)	N/A	N/A	80 (36.32)	—	—	—	—

Fuse Dimensional Details

Approximate Dimensions in Inches (mm)

CLE Type Fuse

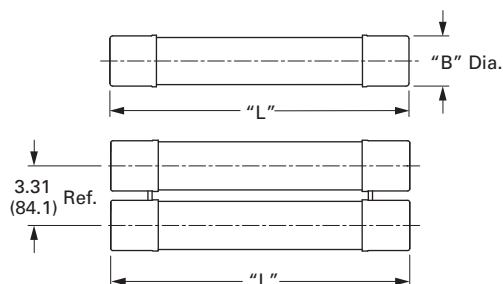

CLE kV	"L"	"B" Dia.
15E–25E	12.90 (327.7)	2.00 (50.8)
10E–450E	17.90 (454.7)	3.00 (76.2)

Notes

- ① See Page V14-T3-38 for diagram of typical mounting.
- ② End fittings supplied only when required.

3.4

Current Limiting Fuses

CLE, HLE, LHLE, AHLE, BHLE, HCL and BHCL Type Fuses

CLE Type



3

CLE Type Current Limiting Fuses 8.3 kV Maximum (7.2 kV Nominal)

Current Rating (Amperes)	Barrel Number	Interrupting Rating rms (kA Sym.)	Heritage Product	Indoor/Outdoor	Performance Curves			Catalog Number
					Minimum Melting Time	Total Clearing Time	Peak Let-Through Current	
15E	1	50	H	Indoor	TC56353204	TC56353304	TC63931703	8CLE-15E
20E	1	50	H	Indoor	TC56353204	TC56353304	TC63931703	8CLE-20E
25E	1	50	H	Indoor	TC56353204	TC56353304	TC63931703	8CLE-25E
10E	1	50	—	Indoor/outdoor	TC70548501	TC70548601	TC70548801	8CLE-10E-D
15E	1	50	—	Indoor/outdoor	TC70548501	TC70548601	TC70548801	8CLE-15E-D
20E	1	50	—	Indoor/outdoor	TC70548501	TC70548601	TC70548801	8CLE-20E-D
25E	1	50	—	Indoor/outdoor	TC70548501	TC70548601	TC70548801	8CLE-25E-D
30E	1	50	—	Indoor/outdoor	TC70548501	TC70548601	TC70548801	8CLE-30E
40E	1	50	—	Indoor/outdoor	TC70546201	TC70546301	TC70547301	8CLE-40E
50E	1	50	—	Indoor/outdoor	TC70546201	TC70546301	TC70547301	8CLE-50E
65E	1	50	—	Indoor/outdoor	TC70546201	TC70546301	TC70547301	8CLE-65E
80E	1	50	—	Indoor/outdoor	TC70546201	TC70546301	TC70547301	8CLE-80E
100E	1	50	—	Indoor/outdoor	TC70546201	TC70546301	TC70547301	8CLE-100E
125E	1	50	—	Indoor/outdoor	TC70546201	TC70546301	TC70547301	8CLE-125E
150E	1	50	—	Indoor/outdoor	TC70546201	TC70546301	TC70547301	8CLE-150E
175E	1	50	—	Indoor/outdoor	TC70546201	TC70546301	TC70547301	8CLE-175E
200E	2	50	—	Indoor/outdoor	TC70546401	TC70546501	TC70547301	8CLE-200E
250E	2	50	—	Indoor/outdoor	TC70546401	TC70546501	TC70547301	8CLE-250E
300E	2	50	—	Indoor/outdoor	TC70546401	TC70546501	TC70547301	8CLE-300E
350E	2	50	—	Indoor/outdoor	TC70546401	TC70546501	TC70547301	8CLE-350E

CLE Type Mountings and Hardware 8.3 kV Maximum (7.2 kV Nominal)

Ampere Rating	Fuse Mounting Type ①	Voltage BIL (kV)	Diameter Approx. Dimensions in Inches (mm)	Clip Center Length	Approximate Shipping Weight Lbs (kg)	Mounting (Including Live Parts, End Fittings) ②		Live Parts (Including End Fittings) ②	End Fittings (Disconnect Only)	
						Porcelain Insulator Catalog Number	Glass-Polyester Insulator Catalog Number	Catalog Number	Catalog Number	
15E-25E	Non-disconnect	75	2.00 (50.8)	14.00 (355.6)	15.50 (393.7)	3 (1.36)	8CLE-PNM-C	8CLE-GNM-C	CLE-NL-C	—
	Disconnect	75					8CLE-PDM-C	8CLE-GDM-C	CLE-DL-C	CLE-DF-C
10E-D-25E-D 30E-175E	Non-disconnect	75	3.00 (76.2)	14.00 (355.6)	17.90 (454.7)	9 (4.09)	8CLE-PNM-D	8CLE-GNM-D	CLE-NL-D	—
	Disconnect	75					8CLE-PDM-D	8CLE-GDM-D	CLE-DL-D	CLE-DF-D
200E-350E	Non-disconnect	75	3.00 (76.2)	14.00 (355.6)	17.90 (454.7)	19 (8.63)	8CLE-PNM-E	8CLE-GNM-E	CLE-NL-E	—
	Disconnect	75					8CLE-PDM-E	8CLE-GDM-E	CLE-DL-E	CLE-DF-E

Fuse Dimensional Details

Approximate Dimensions in Inches (mm)

CLE Type Fuse

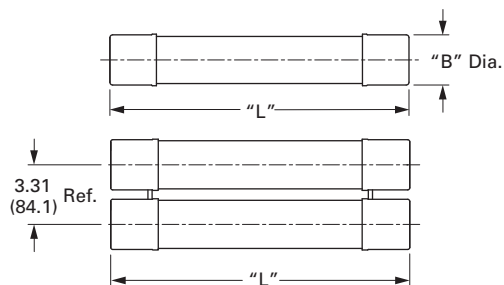

CLE kV	"L"	"B" Dia.
15E-25E	15.50 (393.7)	2.00 (50.8)
10E-350E	17.90 (454.7)	3.00 (76.2)

Notes

- ① See Page V14-T3-38 for diagram of typical mounting.
- ② End fittings supplied only when required.

CLE Type

CLE Type Current Limiting Fuses 15.5 kV Maximum (14.4 kV Nominal)



Current Rating (Amperes)	Barrel Number	Interrupting Rating rms (kA Sym.)	Heritage Product	Indoor/Outdoor	Performance Curves			Catalog Number
					Minimum Melting Time	Total Clearing Time	Peak Let-Through Current	
15E	1	31.5	H	Indoor	TC56353204	TC56353304	TC63931703	15CLE-15E
20E	1	31.5	H	Indoor	TC56353204	TC56353304	TC63931703	15CLE-20E
25E	1	31.5	H	Indoor	TC56353204	TC56353304	TC63931703	15CLE-25E
10E	1	63	—	Indoor/outdoor	TC70548501	TC70548601	TC70548802	15CLE-10E-D
15E	1	63	—	Indoor/outdoor	TC70548501	TC70548601	TC70548802	15CLE-15E-D
20E	1	63	—	Indoor/outdoor	TC70548501	TC70548601	TC70548802	15CLE-20E-D
25E	1	63	—	Indoor/outdoor	TC70548501	TC70548601	TC70548802	15CLE-25E-D
30E	1	63	—	Indoor/outdoor	TC70548501	TC70548601	TC70548802	15CLE-30E
40E	1	63	—	Indoor/outdoor	TC70546801	TC70546901	TC70547501	15CLE-40E
50E	1	63	—	Indoor/outdoor	TC70546801	TC70546901	TC70547501	15CLE-50E
65E	1	63	—	Indoor/outdoor	TC70546801	TC70546901	TC70547501	15CLE-65E
80E	1	63	⓪	Indoor/outdoor	TC70546801	TC70546901	TC70547501	15CLE-80E
100E	1	63	⓪	Indoor/outdoor	TC70546801	TC70546901	TC70547501	15CLE-100E
125E	1	63	⓪	Indoor/outdoor	TC70546801	TC70546901	TC70547501	15CLE-125E
150E	1	63	⓪	Indoor/outdoor	TC70546801	TC70546901	TC70547501	15CLE-150E
175E	2	63	⓪	Indoor/outdoor	TC70547001	TC70547101	TC70547501	15CLE-175E
200E	2	63	⓪	Indoor/outdoor	TC70547001	TC70547101	TC70547501	15CLE-200E
250E	2	63	⓪	Indoor/outdoor	TC70547001	TC70547101	TC70547501	15CLE-250E
300E	2	63	⓪	Indoor/outdoor	TC70547001	TC70547101	TC70547501	15CLE-300E
80E	2	85	H ⓪	Indoor	TC59878302	TC59878402	TC63931604	15CLE2-80E
100E	2	85	H ⓪	Indoor	TC59878302	TC59878402	TC63931604	15CLE2-100E
125X	2	85	H ⓪	Indoor	TC59878302	TC59878402	TC63931604	15CLE2-125X
150E	3	50	H ⓪	Indoor	TC59878302	TC59878402	TC63931604	15CLE3-150E
175E/200X	3	50	H ⓪	Indoor	TC59878302	TC59878402	TC63931604	15CLE3-175E/200X

CLE Type Mountings and Hardware 15.5 kV Maximum (14.4 kV Nominal)

Ampere Rating	Fuse Mounting Type ②	Voltage BIL (kV)	Diameter Approx. Dimensions in Inches (mm)	Clip Center	Length	Approximate Shipping Weight Lbs (kg)	Mounting (Including Live Parts, End Fittings) ②		Live Parts (Including End Fittings) ②	End Fittings (Disconnect Only)
							Porcelain Insulator Catalog Number	Glass-Polyester Insulator Catalog Number		
15E-25E	Non-disconnect	95	2.00 (50.8)	20.00 (508.0)	21.50 (546.1)	4.5 (2.04)	15CLE-PNM-C	15CLE-GNM-C	CLE-NL-D	—
		110	—	—	—	—	15CLE-HPNM-C	—	—	—
	Disconnect	95	—	—	—	—	15CLE-PDM-C	15CLE-GDM-C	CLE-DL-C	CLE-DF-C
		110	—	—	—	—	15CLE-HPDM-C	—	—	—
10E-D-25E-D 30E-150E	Non-disconnect	95	3.00 (76.2)	20.00 (508.0)	23.90 (607.1)	11 (4.99)	15CLE-PNM-D	15CLE-GNM-D	CLE-NL-D	—
		110	—	—	—	—	15CLE-HPM-D	—	—	—
	Disconnect	95	—	—	—	—	15CLE-PDM-D	15CLE-GNM-D	CLE-DL-D	CLE-DF-D
		110	—	—	—	—	15CLE-HPDM-D	—	—	—
175E-300E	Non-disconnect	110	3.00 (76.2)	20.00 (508.0)	23.90 (607.1)	23 (10.44)	15CLE-PNM-E	—	CLE-DL-E	CLE-DF-E
	Disconnect	110	—	—	—	—	15CLE-PDM-E	—	—	—

Fuse Dimensional Details

Approximate Dimensions in Inches (mm)

CLE Type Fuse

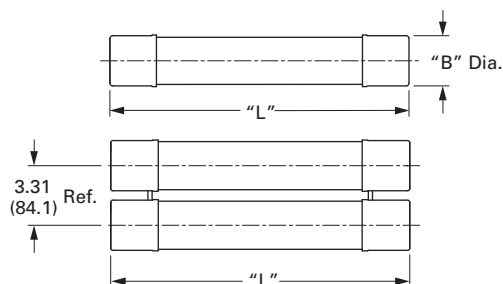

CLE kV	"L"	"B" Dia.
15E-25E	21.50 (546.1)	2.00 (50.8)
10E-300E	23.90 (607.1)	3.00 (76.2)

Notes

- ① For mountings, consult factory.
- ② See Page V14-T3-38 for diagram of typical mounting.
- ③ End fittings supplied only when required.

3.4

Current Limiting Fuses

CLE, HLE, LHLE, AHLE, BHLE, HCL and BHCL Type Fuses

HLE Type

HLE Type

3



HLE Type Current Limiting Fuses 5.5 kV Maximum (4.8 kV Nominal) Interrupting Rating 63 (kA rms Sym.)

Current Rating (Amperes)	Barrel Number	Indoor/Outdoor	Performance Curves			Catalog Number
			Minimum Melting Time	Total Clearing Time	Peak Let-Through Current	
10E	1	Indoor/outdoor	TC70548507	TC70548607	TC70548703	5HLE-10E
15E	1	Indoor/outdoor	TC70548507	TC70548607	TC70548703	5HLE-15E
20E	1	Indoor/outdoor	TC70548507	TC70548607	TC70548703	5HLE-20E
25E	1	Indoor/outdoor	TC70548507	TC70548607	TC70548703	5HLE-25E
30E	1	Indoor/outdoor	TC70548507	TC70548607	TC70548703	5HLE-30E
40E	1	Indoor/outdoor	TC70545805	TC70545905	TC70547603	5HLE-40E
50E	1	Indoor/outdoor	TC70545805	TC70545905	TC70547603	5HLE-50E
65E	1	Indoor/outdoor	TC70545805	TC70545905	TC70547603	5HLE-65E
80E	1	Indoor/outdoor	TC70545805	TC70545905	TC70547603	5HLE-80E
100E	1	Indoor/outdoor	TC70545805	TC70545905	TC70547603	5HLE-100E
125E	1	Indoor/outdoor	TC70545805	TC70545905	TC70547603	5HLE-125E
150E	1	Indoor/outdoor	TC70545805	TC70545905	TC70547603	5HLE-150E
175E	1	Indoor/outdoor	TC70545805	TC70545905	TC70547603	5HLE-175E
200E	1	Indoor/outdoor	TC70545805	TC70545905	TC70547603	5HLE-200E
250E	1	Indoor/outdoor	TC70545805	TC70545905	TC70547603	5HLE-250E
300E	2	Indoor/outdoor	TC70546005	TC70546105	TC70547603	5HLE-300E
350E	2	Indoor/outdoor	TC70546005	TC70546105	TC70547603	5HLE-350E
400E	2	Indoor/outdoor	TC70546005	TC70546105	TC70547603	5HLE-400E
450E	2	Indoor/outdoor	TC70546005	TC70546105	TC70547603	5HLE-450E

HLE Type Mountings and Hardware 5.5 kV Maximum (4.8 kV Nominal)

Ampere Rating	Fuse Mounting Type ①	Voltage BIL (kV)	Diameter Approx.	Clip Center Dimensions in Inches (mm)	Length Inches (mm)	Approximate Shipping Weight Lbs (kg)	Mounting (Including Live Parts, End Fittings) ②		Live Parts (Including End Fittings) ②	End Fittings (Disconnect Only)
							Porcelain Insulator Catalog Number	Glass-Polyester Insulator Catalog Number	Catalog Number	Catalog Number
10E–250E	Non-disconnect	60	3.00 (76.2)	12.00 (304.8)	15.90 (403.9)	8 (3.63)	5HLE-PNM-D	5HLE-GNM-D	CLE-NL-D	—
	Disconnect	60					5HLE-PDM-D	5HLE-GDM-D	CLE-DL-D	CLE-DF-D
300E–450E	Non-disconnect	60	3.00 (76.2)	12.00 (304.8)	15.90 (403.9)	17 (7.72)	5HLE-PNM-E	5HLE-GNM-E	CLE-NL-E	—
	Disconnect	60					5HLE-PDM-E	5HLE-GDM-E	CLE-DL-E	CLE-DF-D

Fuse Dimensional Details

Approximate Dimensions in Inches (mm)

HLE Type Fuse

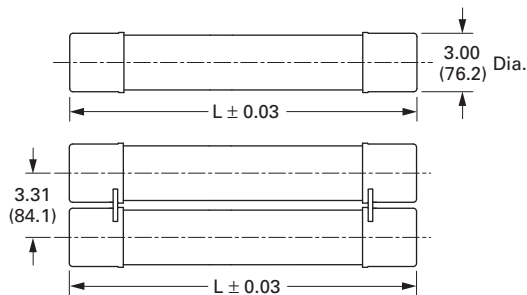

HLE kV	L ± 0.03
5.5	15.88 (403.4)

Notes

- ① See Page V14-T3-38 for diagram of typical mounting.
- ② End fittings supplied only when required.

HLE Type



HLE Type Current Limiting Fuses 8.3 kV Maximum (7.2 kV Nominal) Interrupting Rating 50 (kA Sym.)

Current Rating (Amperes)	Barrel Number	Indoor/Outdoor	Performance Curves			Catalog Number
			Minimum Melting Time	Total Clearing Time	Peak Let-Through Current	
10E	1	Indoor/outdoor	TC70548507	TC70548607	TC70548804	8HLE-10E
15E	1	Indoor/outdoor	TC70548507	TC70548607	TC70548804	8HLE-15E
20E	1	Indoor/outdoor	TC70548507	TC70548607	TC70548804	8HLE-20E
25E	1	Indoor/outdoor	TC70548507	TC70548607	TC70548804	8HLE-25E
30E	1	Indoor/outdoor	TC70548507	TC70548607	TC70548804	8HLE-30E
40E	1	Indoor/outdoor	TC70546203	TC70546303	TC70547201	8HLE-40E
50E	1	Indoor/outdoor	TC70546203	TC70546303	TC70547201	8HLE-50E
65E	1	Indoor/outdoor	TC70546203	TC70546303	TC70547201	8HLE-65E
80E	1	Indoor/outdoor	TC70546203	TC70546303	TC70547201	8HLE-80E
100E	1	Indoor/outdoor	TC70546203	TC70546303	TC70547201	8HLE-100E
125E	1	Indoor/outdoor	TC70546203	TC70546303	TC70547201	8HLE-125E
150E	1	Indoor/outdoor	TC70546203	TC70546303	TC70547201	8HLE-150E
175E	1	Indoor/outdoor	TC70546203	TC70546303	TC70547201	8HLE-175E
200E	2	Indoor/outdoor	TC70546403	TC70546503	TC70547201	8HLE-200E
250E	2	Indoor/outdoor	TC70546403	TC70546503	TC70547201	8HLE-250E
300E	2	Indoor/outdoor	TC70546403	TC70546503	TC70547201	8HLE-300E
350E	2	Indoor/outdoor	TC70546403	TC70546503	TC70547201	8HLE-350E

HLE Type Mountings and Hardware 8.3 kV Maximum (7.2 kV Nominal)

Ampere Rating	Fuse Mounting Type ①	Voltage BIL (kV)	Diameter Approx. Dimensions in Inches (mm)	Clip Center Length	Approximate Shipping Weight Lbs (kg)	Mounting (Including Live Parts, End Fittings) ②		Live Parts (Including End Fittings) ②	End Fittings (Disconnect Only)	
						Porcelain Insulator Catalog Number	Glass-Polyester Insulator Catalog Number	Catalog Number	Catalog Number	
10E–175E	Non-disconnect	75	3.00 (76.2)	12.00 (304.8)	15.90 (403.9)	8 (3.63)	8HLE-PNM-D	8HLE-GNM-D	CLE-NL-D	—
	Disconnect	75					8HLE-PDM-D	8HLE-GDM-D	CLE-DL-D	CLE-DF-D
200E–350E	Non-disconnect	75					8HLE-PNM-E	8HLE-GNM-E	CLE-NL-E	—
	Disconnect	75					8HLE-PDM-E	8HLE-GDM-E	CLE-DL-E	CLE-DF-E

Fuse Dimensional Details

Approximate Dimensions in Inches (mm)

HLE Type Fuse

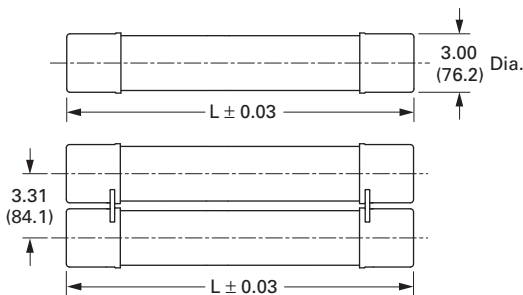

HLE kV	L ± 0.03
8.3	15.88 (403.4)

Notes

- ① See Page V14-T3-38 for diagram of typical mounting.
- ② End fittings supplied only when required.

3.4

Current Limiting Fuses

CLE, HLE, LHLE, AHLE, BHLE, HCL and BHCL Type Fuses

HLE Type

HLE Type Current Limiting Fuses 15.5 kV Maximum (14.4 kV Nominal)



3

Current Rating (Amperes)	Barrel Number	Interrupting Rating rms (kA Sym.)	Indoor/Outdoor	Performance Curves			Catalog Number
				Minimum Melting Time	Total Clearing Time	Peak Let-Through Current	
10E	1	63	Indoor/outdoor	TC70548507	TC70548607	TC70548805	15HLE-10E
15E	1	63	Indoor/outdoor	TC70548507	TC70548607	TC70548805	15HLE-15E
20E	1	63	Indoor/outdoor	TC70548507	TC70548607	TC70548805	15HLE-20E
25E	1	63	Indoor/outdoor	TC70548507	TC70548607	TC70548805	15HLE-25E
30E	1	63	Indoor/outdoor	TC70548507	TC70548607	TC70548805	15HLE-30E
40E	1	63	Indoor/outdoor	TC70546601	TC70546701	TC70547401	15HLE-40E
50E	1	63	Indoor/outdoor	TC70546601	TC70546701	TC70547401	15HLE-50E
65E	1	63	Indoor/outdoor	TC70546601	TC70546701	TC70547401	15HLE-65E
80E	1	63	Indoor/outdoor	TC70546601	TC70546701	TC70547401	15HLE-80E
100E	1	63	Indoor/outdoor	TC70546601	TC70546701	TC70547401	15HLE-100E
125E	1	63	Indoor/outdoor	TC70546601	TC70546701	TC70547401	15HLE-125E
150E	2	63	Indoor/outdoor	TC70546601	TC70546701	TC70547401	15HLE-150E
175E	2	63	Indoor/outdoor	TC70546601	TC70546701	TC70547401	15HLE-175E
200E	2	63	Indoor/outdoor	TC70546601	TC70546701	TC70547401	15HLE-200E
250E	2	63	Indoor/outdoor	TC70546601	TC70546701	TC70547401	15HLE-250E

HLE Type Mountings and Hardware 15.5 kV Maximum (14.4 kV Nominal)

Ampere Rating	Fuse Mounting Type ①	Voltage BIL (kV)	Diameter Approx. Dimensions in Inches (mm)	Clip Center Approx. Dimensions in Inches (mm)	Length Approx. Dimensions in Inches (mm)	Approximate Shipping Weight Lbs (kg)	Mounting (Including Live Parts, End Fittings) ②		Live Parts (Including End Fittings) ②	End Fittings (Disconnect Only)
							Porcelain Insulator Catalog Number	Glass-Polyester Insulator Catalog Number	Catalog Number	Catalog Number
10E–175E	Non-disconnect	95	3.00 (76.2)	15.00 (381.0)	18.90 (480.1)	10 (4.54)	15HLE-PNM-D	15HLE-GNM-D	CLE-NL-D	—
	Disconnect	95					15HLE-PDM-D	15HLE-GDM-D	CLE-DL-D	CLE-DF-D
150E–250E	Non-disconnect	95	3.00 (76.2)	15.00 (381.0)	18.90 (480.1)	21 (9.53)	15HLE-PNM-E	—	CLE-NL-E	—
	Disconnect	95					15HLE-PDM-E	—	CLE-DL-E	CLE-DF-E

Fuse Dimensional Details

Approximate Dimensions in Inches (mm)

HLE Type Fuse

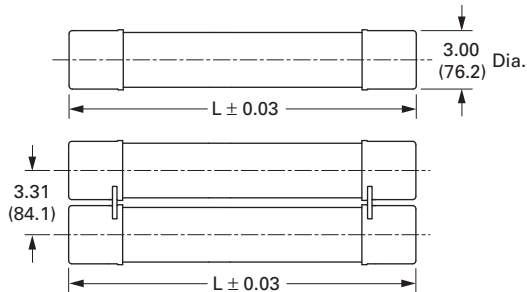

HLE kV	L ± 0.03
15.5	18.88 (479.6)

Notes

- ① See Page V14-T3-38 for diagram of typical mounting.
- ② End fittings supplied only when required.

LHLE Type

LHLE Type

LHLE Type Current Limiting Fuses 15.5 kV Maximum (14.4 kV Nominal) Indoor/Outdoor.



Current Rating (Amperes)	Barrel Number	Approximate Dimensions in Inches (mm)		Approximate Shipping Weight Lbs (kg)	Performance Curves			Catalog Number
		Diameter	Length		Minimum Melting Time	Total Clearing Time	Peak Let-Through Current	
65E	1	3.00 (76.2)	20.53 (521.5)	10.5 (4.80)	TC66703203	TC66703303	TC70547404	15LHLE-65E
80E	1	3.00 (76.2)	20.53 (521.5)	10.5 (4.80)	TC66703203	TC66703303	TC70547404	15LHLE-80E
100E	1	3.00 (76.2)	20.53 (521.5)	10.5 (4.80)	TC66703203	TC66703303	TC70547404	15LHLE-100E
125E	1	3.00 (76.2)	20.53 (521.5)	10.5 (4.80)	TC66703203	TC66703303	TC70547404	15LHLE-125E
150E	1	3.00 (76.2)	20.53 (521.5)	10.5 (4.80)	TC66703203	TC66703303	TC70547404	15LHLE-150E
125E	2	3.00 (76.2)	20.53 (521.5)	21.0 (9.50)	TC66703203	TC66703303	TC70547404	15LHLE2-125E
150E	2	3.00 (76.2)	20.53 (521.5)	21.0 (9.50)	TC66703203	TC66703303	TC70547404	15LHLE2-150E
175E	2	3.00 (76.2)	20.53 (521.5)	21.0 (9.50)	TC66703203	TC66703303	TC70547404	15LHLE-175E
200E	2	3.00 (76.2)	20.53 (521.5)	21.0 (9.50)	TC66703203	TC66703303	TC70547404	15LHLE-200E
250E	2	3.00 (76.2)	20.53 (521.5)	21.0 (9.50)	TC66703203	TC66703303	TC70547404	15LHLE-250E
300E	2	3.00 (76.2)	20.53 (521.5)	21.0 (9.50)	TC66703203	TC66703303	TC70547404	15LHLE-300E

LHLE Type Mountings and Hardware 15.5 kV Maximum (14.4 kV Nominal)

Ampere Rating	Fuse Mounting Type	Diameter Approximate Dimensions in Inches (mm)	Clip Center	Length	Live Parts (Including End Fittings)	End Fittings (Disconnect Only)
					Catalog Number	Catalog Number
65E–150E Single barrel	Non-disconnect	3.00 (76.2)	18.00 (457.0)	20.53 (521.5)	CLE-NL-D	—
	Disconnect				CLE-DL-D	CLE-DF-D
125E–300E Double barrel	Non-disconnect	3.00 (76.2)	18.00 (457.0)	20.53 (521.5)	CLE-NL-E	—
	Disconnect				CLE-DL-E	CLE-DF-E

Fuse Dimensional Details

Approximate Dimensions in Inches (mm)

LHLE Type Fuse

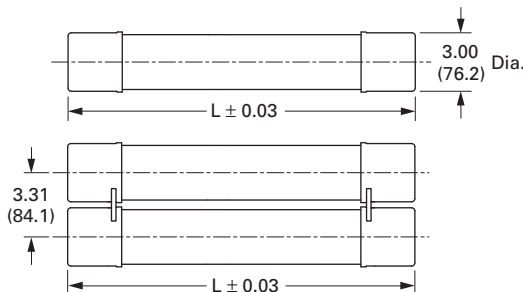

LHLE kV	L ± 0.03
15.5	20.53 (521.5)

3.4

Current Limiting Fuses

CLE, HLE, LHLE, AHLE, BHLE, HCL and BHCL Type Fuses

AHLE Type

5AHLE Type Current-Limiting Fuse Units 5.5 kV Maximum (4.8 kV Nominal)

Current Rating (Amperes)	Barrel Number	Interrupting Rating rms (kA Sym.)	Approximate Shipping Weight Lbs (kg)	Performance Curves			Catalog Number
				Minimum Melting Time	Total Clearing Time	Peak Let-Through Current	
10E	1	63	8 (3.6)	TC70548507	TC70548607	TC70548703	5AHLE-10E
15E	1	63	8 (3.6)	TC70548507	TC70548607	TC70548703	5AHLE-15E
20E	1	63	8 (3.6)	TC70548507	TC70548607	TC70548703	5AHLE-20E
25E	1	63	8 (3.6)	TC70548507	TC70548607	TC70548703	5AHLE-25E
30E	1	63	8 (3.6)	TC70548507	TC70548607	TC70548703	5AHLE-30E
40E	1	63	8 (3.6)	TC70545805	TC70545905	TC70547603	5AHLE-40E
50E	1	63	8 (3.6)	TC70545805	TC70545905	TC70547603	5AHLE-50E
65E	1	63	8 (3.6)	TC70545805	TC70545905	TC70547603	5AHLE-65E
80E	1	63	8 (3.6)	TC70545805	TC70545905	TC70547603	5AHLE-80E
100E	1	63	8 (3.6)	TC70545805	TC70545905	TC70547603	5AHLE-100E
125E	1	63	8 (3.6)	TC70545805	TC70545905	TC70547603	5AHLE-125E
150E	1	63	8 (3.6)	TC70545805	TC70545905	TC70547603	5AHLE-150E
175E	1	63	8 (3.6)	TC70545805	TC70545905	TC70547603	5AHLE-175E
200E	1	63	8 (3.6)	TC70545805	TC70545905	TC70547603	5AHLE-200E
250E	1	63	8 (3.6)	TC70545805	TC70545905	TC70547603	5AHLE-250E
300E	2	63	17 (7.8)	TC70546005	TC70546105	TC70547603	5AHLE-300E
350E	2	63	17 (7.8)	TC70546005	TC70546105	TC70547603	5AHLE-350E
400E	2	63	17 (7.8)	TC70546005	TC70546105	TC70547603	5AHLE-400E
450E	2	63	17 (7.8)	TC70546005	TC70546105	TC70547603	5AHLE-450E

8AHLE Type Current-Limiting Fuse Units 8.3 kV Maximum (7.2 kV Nominal)

Current Rating (Amperes)	Barrel Number	Interrupting Rating rms (kA Sym.)	Approximate Shipping Weight Lbs (kg)	Performance Curves			Catalog Number
				Minimum Melting Time	Total Clearing Time	Peak Let-Through Current	
10E	1	50	8 (3.6)	TC70548507	TC70548607	TC70548804	8AHLE-10E
15E	1	50	8 (3.6)	TC70548507	TC70548607	TC70548804	8AHLE-15E
20E	1	50	8 (3.6)	TC70548507	TC70548607	TC70548804	8AHLE-20E
25E	1	50	8 (3.6)	TC70548507	TC70548607	TC70548804	8AHLE-25E
30E	1	50	8 (3.6)	TC70548507	TC70548607	TC70548804	8AHLE-30E
40E	1	50	8 (3.6)	TC70546203	TC70546303	TC70547201	8AHLE-40E
50E	1	50	8 (3.6)	TC70546203	TC70546303	TC70547201	8AHLE-50E
65E	1	50	8 (3.6)	TC70546203	TC70546303	TC70547201	8AHLE-65E
80E	1	50	8 (3.6)	TC70546203	TC70546303	TC70547201	8AHLE-80E
100E	1	50	8 (3.6)	TC70546203	TC70546303	TC70547201	8AHLE-100E
125E	1	50	8 (3.6)	TC70546203	TC70546303	TC70547201	8AHLE-125E
150E	1	50	8 (3.6)	TC70546203	TC70546303	TC70547201	8AHLE-150E
175E	1	50	8 (3.6)	TC70546203	TC70546303	TC70547201	8AHLE-175E
200E	2	50	17 (7.8)	TC70546403	TC70546503	TC70547201	8AHLE-200E
250E	2	50	17 (7.8)	TC70546403	TC70546503	TC70547201	8AHLE-250E
300E	2	50	17 (7.8)	TC70546403	TC70546503	TC70547201	8AHLE-300E
350E	2	50	17 (7.8)	TC70546403	TC70546503	TC70547201	8AHLE-350E

Note: These fuses are equipped for mounting in Eaton Ampgard motor starting assemblies.

BHLE Type

BHLE Type Current Limiting Fuses 5.5 kV Maximum (4.8 kV Nominal), Indoor, Bolt-In

Current Rating (Amperes)	Barrel Number	Interrupting Rating rms (kA Sym.)	Diameter Approximate Dimensions in Inches (mm)	Length	Approximate Shipping Weight Lbs (kg)	Performance Curves			Catalog Number
						Minimum Melting Time	Total Clearing Time	Peak Let-Through Current	
10E	1	63	3.00 (76.2)	15.90 (403.9)	8 (3.63)	TC70548507	TC70548607	TC70548703	5BHLE-10E
15E	1	63	3.00 (76.2)	15.90 (403.9)	8 (3.63)	TC70548507	TC70548607	TC70548703	5BHLE-15E
20E	1	63	3.00 (76.2)	15.90 (403.9)	8 (3.63)	TC70548507	TC70548607	TC70548703	5BHLE-20E
25E	1	63	3.00 (76.2)	15.90 (403.9)	8 (3.63)	TC70548507	TC70548607	TC70548703	5BHLE-25E
30E	1	63	3.00 (76.2)	15.90 (403.9)	8 (3.63)	TC70548507	TC70548607	TC70548703	5BHLE-30E
40E	1	63	3.00 (76.2)	15.90 (403.9)	8 (3.63)	TC70545805	TC70545905	TC70547603	5BHLE-40E
50E	1	63	3.00 (76.2)	15.90 (403.9)	8 (3.63)	TC70545805	TC70545905	TC70547603	5BHLE-50E
65E	1	63	3.00 (76.2)	15.90 (403.9)	8 (3.63)	TC70545805	TC70545905	TC70547603	5BHLE-65E
80E	1	63	3.00 (76.2)	15.90 (403.9)	8 (3.63)	TC70545805	TC70545905	TC70547603	5BHLE-80E
100E	1	63	3.00 (76.2)	15.90 (403.9)	8 (3.63)	TC70545805	TC70545905	TC70547603	5BHLE-100E
125E	1	63	3.00 (76.2)	15.90 (403.9)	8 (3.63)	TC70545805	TC70545905	TC70547603	5BHLE-125E
150E	1	63	3.00 (76.2)	15.90 (403.9)	8 (3.63)	TC70545805	TC70545905	TC70547603	5BHLE-150E
175E	1	63	3.00 (76.2)	15.90 (403.9)	8 (3.63)	TC70545805	TC70545905	TC70547603	5BHLE-175E
200E	1	63	3.00 (76.2)	15.90 (403.9)	8 (3.63)	TC70545805	TC70545905	TC70547603	5BHLE-200E
250E	1	63	3.00 (76.2)	15.90 (403.9)	8 (3.63)	TC70545805	TC70545905	TC70547603	5BHLE-250E
300E	2	63	3.00 (76.2)	15.90 (403.9)	17 (7.72)	TC70546005	TC70546105	TC70547603	5BHLE-300E
350E	2	63	3.00 (76.2)	15.90 (403.9)	17 (7.72)	TC70546005	TC70546105	TC70547603	5BHLE-350E
400E	2	63	3.00 (76.2)	15.90 (403.9)	17 (7.72)	TC70546005	TC70546105	TC70547603	5BHLE-400E
450E	2	63	3.00 (76.2)	15.90 (403.9)	17 (7.72)	TC70546005	TC70546105	TC70547603	5BHLE-450E

Fuse Dimensional Details

Approximate Dimensions in Inches (mm)

5BHLE Type Fuse—Single Barrel

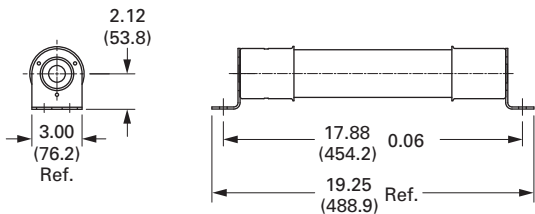

5BHLE Type Fuse—Double Barrel

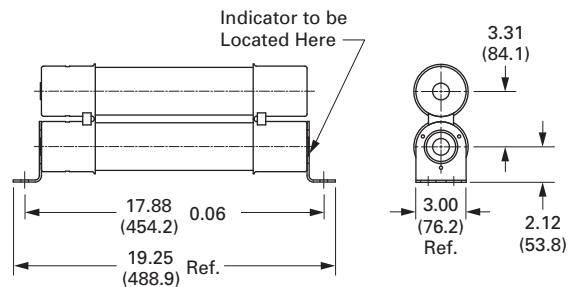

3.4

Current Limiting Fuses

CLE, HLE, LHLE, AHLE, BHLE, HCL and BHCL Type Fuses

3

BHLE Type Current Limiting Fuses 8.3 kV Maximum (7.2 kV Nominal), Indoor, Bolt-In

Current Rating (Amperes)	Barrel Number	Interrupting Rating rms (kA Sym.)	Diameter Approximate Dimensions in Inches (mm)	Length Approximate Dimensions in Inches (mm)	Approximate Shipping Weight Lbs (kg)	Performance Curves Minimum Melting Time	Performance Curves Total Clearing Time	Peak Let-Through Current	Catalog Number
10E	1	50	3.00 (76.2)	15.90 (403.9)	8 (3.63)	TC70548507	TC70548607	TC70548804	8BHLE-10E
15E	1	50	3.00 (76.2)	15.90 (403.9)	8 (3.63)	TC70548507	TC70548607	TC70548804	8BHLE-15E
20E	1	50	3.00 (76.2)	15.90 (403.9)	8 (3.63)	TC70548507	TC70548607	TC70548804	8BHLE-20E
25E	1	50	3.00 (76.2)	15.90 (403.9)	8 (3.63)	TC70548507	TC70548607	TC70548804	8BHLE-25E
30E	1	50	3.00 (76.2)	15.90 (403.9)	8 (3.63)	TC70548507	TC70548607	TC70548804	8BHLE-30E
40E	1	50	3.00 (76.2)	15.90 (403.9)	8 (3.63)	TC70546203	TC70546303	TC70547201	8BHLE-40E
50E	1	50	3.00 (76.2)	15.90 (403.9)	8 (3.63)	TC70546203	TC70546303	TC70547201	8BHLE-50E
65E	1	50	3.00 (76.2)	15.90 (403.9)	8 (3.63)	TC70546203	TC70546303	TC70547201	8BHLE-65E
80E	1	50	3.00 (76.2)	15.90 (403.9)	8 (3.63)	TC70546203	TC70546303	TC70547201	8BHLE-80E
100E	1	50	3.00 (76.2)	15.90 (403.9)	8 (3.63)	TC70546203	TC70546303	TC70547201	8BHLE-100E
125E	1	50	3.00 (76.2)	15.90 (403.9)	8 (3.63)	TC70546203	TC70546303	TC70547201	8BHLE-125E
150E	1	50	3.00 (76.2)	15.90 (403.9)	8 (3.63)	TC70546203	TC70546303	TC70547201	8BHLE-150E
175E	1	50	3.00 (76.2)	15.90 (403.9)	8 (3.63)	TC70546203	TC70546303	TC70547201	8BHLE-175E
200E	2	50	3.00 (76.2)	15.90 (403.9)	17 (7.72)	TC70546403	TC70546503	TC70547201	8BHLE-200E
250E	2	50	3.00 (76.2)	15.90 (403.9)	17 (7.72)	TC70546403	TC70546503	TC70547201	8BHLE-250E
300E	2	50	3.00 (76.2)	15.90 (403.9)	17 (7.72)	TC70546403	TC70546503	TC70547201	8BHLE-300E
350E	2	50	3.00 (76.2)	15.90 (403.9)	17 (7.72)	TC70546403	TC70546503	TC70547201	8BHLE-350E

Fuse Dimensional Details

Approximate Dimensions in Inches (mm)

8BHLE Type Fuse—Single Barrel

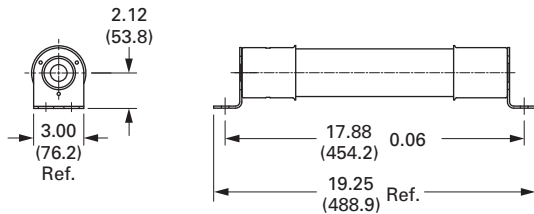

8BHLE Type Fuse—Double Barrel

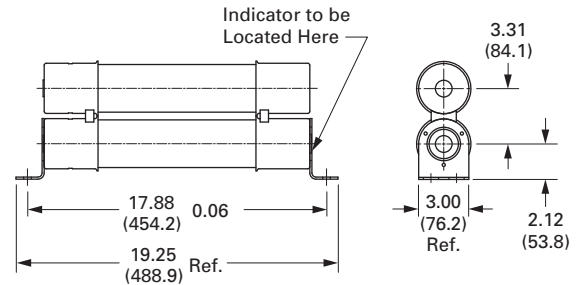

BHLE Type Current Limiting Fuses 15.5 kV Maximum (14.4 kV Nominal), Indoor/Outdoor, Bolt-In

Current Rating (Amperes)	Barrel Number	Interrupting Rating rms (kA Sym.)	Diameter Approximate Dimensions in Inches (mm)	Length Approximate Dimensions in Inches (mm)	Approximate Shipping Weight Lbs (kg)	Performance Curves			Catalog Number
						Minimum Melting Time	Total Clearing Time	Peak Let-Through Current	
10E	1	63	3.00 (76.2)	18.90 (480.1)	10 (4.54)	TC70548507	TC70548607	TC70548805	15BHLE-10E
15E	1	63	3.00 (76.2)	18.90 (480.1)	10 (4.54)	TC70548507	TC70548607	TC70548805	15BHLE-15E
20E	1	63	3.00 (76.2)	18.90 (480.1)	10 (4.54)	TC70548507	TC70548607	TC70548805	15BHLE-20E
25E	1	63	3.00 (76.2)	18.90 (480.1)	10 (4.54)	TC70548507	TC70548607	TC70548805	15BHLE-25E
30E	1	63	3.00 (76.2)	18.90 (480.1)	10 (4.54)	TC70548507	TC70548607	TC70548805	15BHLE-30E
40E	1	63	3.00 (76.2)	18.90 (480.1)	10 (4.54)	TC70546601	TC70546701	TC70547401	15BHLE-40E
50E	1	63	3.00 (76.2)	18.90 (480.1)	10 (4.54)	TC70546601	TC70546701	TC70547401	15BHLE-50E
65E	1	63	3.00 (76.2)	18.90 (480.1)	10 (4.54)	TC70546601	TC70546701	TC70547401	15BHLE-65E
80E	1	63	3.00 (76.2)	18.90 (480.1)	10 (4.54)	TC70546601	TC70546701	TC70547401	15BHLE-80E
100E	1	63	3.00 (76.2)	18.90 (480.1)	10 (4.54)	TC70546601	TC70546701	TC70547401	15BHLE-100E
125E	1	63	3.00 (76.2)	18.90 (480.1)	10 (4.54)	TC70546601	TC70546701	TC70547401	15BHLE-125E
150E	2	63	3.00 (76.2)	18.90 (480.1)	21 (9.53)	TC70546601	TC70546701	TC70547401	15BHLE-150E
175E	2	63	3.00 (76.2)	18.90 (480.1)	21 (9.53)	TC70546601	TC70546701	TC70547401	15BHLE-175E
200E	2	63	3.00 (76.2)	18.90 (480.1)	21 (9.53)	TC70546601	TC70546701	TC70547401	15BHLE-200E
250E	2	63	3.00 (76.2)	18.90 (480.1)	21 (9.53)	TC70546601	TC70546701	TC70547401	15BHLE-250E

Fuse Dimensional Details

Approximate Dimensions in Inches (mm)

15BHLE Type Fuse—Single Barrel

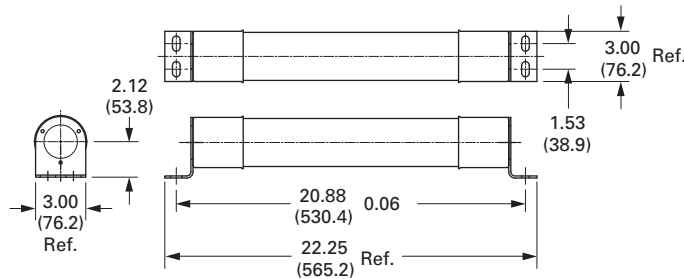

15BHLE Type Fuse—Double Barrel

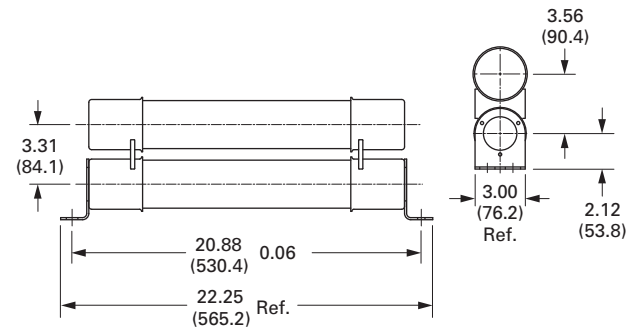

3.4

Current Limiting Fuses

CLE, HLE, LHLE, AHLE, BHLE, HCL and BHCL Type Fuses

HCL Type

HCL Type Current Limiting Fuses 5.5 kV Maximum (4.8 kV Nominal), Indoor

Current Rating (Amperes)	Barrel Number	Interrupting Rating rms (kA Sym.)	Approximate Diameter in Inches (mm)	Clip Center	Approximate Shipping Weight Lbs (kg)	Mounting Type	Live Parts (Includes End Fittings) Catalog Number	Performance Curves			Catalog Number
								Minimum Melting Time	Total Clearing Time	Peak Let-Through Current	
10E	1	63	3.00 (76.2)	Clip-lock	9 (4.09)	Non-disconnect	HCL-NL-1	TC70548505	TC70548605	TC70548702	5HCL-10E
15E	1	63	3.00 (76.2)	Clip-lock	9 (4.09)	Non-disconnect	HCL-NL-1	TC70548505	TC70548605	TC70548702	5HCL-15E
20E	1	63	3.00 (76.2)	Clip-lock	9 (4.09)	Non-disconnect	HCL-NL-1	TC70548505	TC70548605	TC70548702	5HCL-20E
25E	1	63	3.00 (76.2)	Clip-lock	9 (4.09)	Non-disconnect	HCL-NL-1	TC70548505	TC70548605	TC70548702	5HCL-25E
30E	1	63	3.00 (76.2)	Clip-lock	9 (4.09)	Non-disconnect	HCL-NL-1	TC70548505	TC70548605	TC70548702	5HCL-30E
40E	1	63	3.00 (76.2)	Clip-lock	9 (4.09)	Non-disconnect	HCL-NL-1	TC70545803	TC70545903	TC70547602	5HCL-40E
50E	1	63	3.00 (76.2)	Clip-lock	9 (4.09)	Non-disconnect	HCL-NL-1	TC70545803	TC70545903	TC70547602	5HCL-50E
65E	1	63	3.00 (76.2)	Clip-lock	9 (4.09)	Non-disconnect	HCL-NL-1	TC70545803	TC70545903	TC70547602	5HCL-65E
80E	1	63	3.00 (76.2)	Clip-lock	9 (4.09)	Non-disconnect	HCL-NL-1	TC70545803	TC70545903	TC70547602	5HCL-80E
100E	1	63	3.00 (76.2)	Clip-lock	9 (4.09)	Non-disconnect	HCL-NL-1	TC70545803	TC70545903	TC70547602	5HCL-100E
125E	1	63	3.00 (76.2)	Clip-lock	9 (4.09)	Non-disconnect	HCL-NL-1	TC70545803	TC70545903	TC70547602	5HCL-125E
150E	1	63	3.00 (76.2)	Clip-lock	9 (4.09)	Non-disconnect	HCL-NL-1	TC70545803	TC70545903	TC70547602	5HCL-150E
200E	1	63	3.00 (76.2)	Clip-lock	10 (4.54)	Non-disconnect	HCL-NL-1	TC70545803	TC70545903	TC70547602	5HCL-200E
250E	1	63	3.00 (76.2)	Clip-lock	10 (4.54)	Non-disconnect	HCL-NL-1	TC70545803	TC70545903	TC70547602	5HCL-250E
300E	2	63	3.00 (76.2)	Clip-lock	20 (9.08)	Non-disconnect	HCL-NL-1	TC70546003	TC70516103	TC70547602	5HCL-300E
400E	2	63	3.00 (76.2)	Clip-lock	20 (9.08)	Non-disconnect	HCL-NL-1	TC70546003	TC70516103	TC70547602	5HCL-400E
450E	2	63	3.00 (76.2)	Clip-lock	20 (9.08)	Non-disconnect	HCL-NL-1	TC70546003	TC70516103	TC70547602	5HCL-450E
500E	2	63	3.00 (76.2)	Clip-lock	20 (9.08)	Non-disconnect	HCL-NL-1	TC66703401	TC66703501	TC66703701	5HCL-500E
600E	2	63	3.00 (76.2)	Clip-lock	20 (9.08)	Non-disconnect	HCL-NL-1	TC66703401	TC66703501	TC66703701	5HCL-600E
750E	3	63	3.00 (76.2)	Bolt-in	30 (13.62)	—	—	TC66703401	TC66703501	TC66703701	5HCL-750E
	3	63	3.00 (76.2)	Bolt-in	30 (13.62)	—	—	TC66703401	TC66703501	TC66703701	5BHCL-750E
900E	3	63	3.00 (76.2)	Bolt-in	30 (13.62)	—	—	TC66703401	TC66703501	TC66703701	5HCL-900E
	3	63	3.00 (76.2)	Bolt-in	30 (13.62)	—	—	TC66703401	TC66703501	TC66703701	5BHCL-900E

HCL Type Current Limiting Fuses (15.5 kV Maximum, 14.4 kV Nominal), Indoor

Current Rating (Amperes)	Barrel Number	Interrupting Rating rms (kA Sym.)	Approximate Diameter in Inches (mm)	Clip Center	Approximate Shipping Weight Lbs (kg)	Mounting Type	Live Parts (Includes End Fittings) Catalog Number	Performance Curves			Catalog Number
								Minimum Melting Time	Total Clearing Time	Peak Let-Through Current	
10E	1	63	3.00 (76.2)	Clip-lock	10 (4.54)	Non-disconnect	HCL-NL-1	TC70548503	TC70548603	TC70548803	15HCL-10E
15E	1	63	3.00 (76.2)	Clip-lock	10 (4.54)	Non-disconnect	HCL-NL-1	TC70548503	TC70548603	TC70548803	15HCL-15E
20E	1	63	3.00 (76.2)	Clip-lock	10 (4.54)	Non-disconnect	HCL-NL-1	TC70548503	TC70548603	TC70548803	15HCL-20E
25E	1	63	3.00 (76.2)	Clip-lock	10 (4.54)	Non-disconnect	HCL-NL-1	TC70548503	TC70548603	TC70548803	15HCL-25E
30E	1	63	3.00 (76.2)	Clip-lock	10 (4.54)	Non-disconnect	HCL-NL-1	TC70548503	TC70548603	TC70548803	15HCL-30E
40E	1	63	3.00 (76.2)	Clip-lock	10 (4.54)	Non-disconnect	HCL-NL-1	TC66703201	TC66703301	TC70547402	15HCL-40E
50E	1	63	3.00 (76.2)	Clip-lock	10 (4.54)	Non-disconnect	HCL-NL-1	TC66703201	TC66703301	TC70547402	15HCL-50E
65E	1	50	3.00 (76.2)	Clip-lock	12 (5.45)	Non-disconnect	HCL-NL-1	TC66703201	TC66703301	TC70547402	15HCL-65E
80E	1	50	3.00 (76.2)	Clip-lock	12 (5.45)	Non-disconnect	HCL-NL-1	TC66703201	TC66703301	TC70547402	15HCL-80E
100E	1	50	3.00 (76.2)	Clip-lock	12 (5.45)	Non-disconnect	HCL-NL-1	TC66703201	TC66703301	TC70547402	15HCL-100E
125E	1	50	3.00 (76.2)	Clip-lock	12 (5.45)	Non-disconnect	HCL-NL-1	TC66703201	TC66703301	TC70547402	15HCL-125E
150E	2	50	3.00 (76.2)	Clip-lock	24 (10.90)	Non-disconnect	HCL-NL-1	TC66703201	TC66703301	TC70547402	15HCL-150E
200E	2	50	3.00 (76.2)	Clip-lock	24 (10.90)	Non-disconnect	HCL-NL-1	TC66703201	TC66703301	TC70547402	15HCL-200E
250E	2	50	3.00 (76.2)	Clip-lock	24 (10.90)	Non-disconnect	HCL-NL-1	TC66703201	TC66703301	TC70547402	15HCL-250E
300E	2	50	3.00 (76.2)	Clip-lock	24 (10.90)	Non-disconnect	HCL-NL-1	TC66703201	TC66703301	TC70547402	15HCL-300E

Fuse Dimensional Details

Approximate Dimensions in Inches (mm)

5.5 and 15.5 kV Clip Lock Mounted

Ampere Rating	Number of Barrels	Figure Number	A	B	C	Interrupting Rating rms (kA Sym.)
5.5 kV Maximum—Clip Lock Style—15.25-Inch (387.4 mm) Clip Centers—3.00-Inch (76.2 mm) Barrel Diameter						
10E–150E	1	A	16.81 (427.0)	16.12 (409.4)	①	63
5.5 kV Maximum—Clip Lock Style—21.25-Inch (539.8 mm) Clip Centers—3.00-Inch (76.2 mm) Barrel Diameter						
200E–600E	1	A	22.81 (579.4)	22.12 (561.8)	①	63

15.5 kV Clip Lock Mounted

Ampere Rating	Number of Barrels	Figure Number	A	B	C	Interrupting Rating rms (kA Sym.)
15.5 kV Maximum—Clip Lock Style—21.25-Inch (539.8 mm) Clip Centers—3.00-Inch (76.2 mm) Barrel Diameter						
65E–125E	1	A	22.81 (579.4)	22.12 (561.8)	①	63
150E–300E	2	B	22.81 (579.4)	22.12 (561.8)	①	50
15.5 kV Maximum—Clip Lock Style—18.25-Inch (463.6 mm) Clip Centers—3.00-Inch (76.2 mm) Barrel Diameter						
10E–50E	1	A	19.81 (503.2)	19.12 (485.6)	①	63

Bolt-In Series—5.5 kV

Ampere Rating	Number of Barrels	Figure Number	A	B	C	D	Interrupting Rating rms (kA Sym.)
5.5 kV Maximum—Bolt-in Style—23.73-Inch (602.7 mm) Hole Centers—3.00-Inch (76.2 mm) Barrel Diameter							
750E, 900E	3	C	25.11 (637.8)	22.37 (568.2)	23.73 (602.7)	①	63

HCL-14 Type Fuse

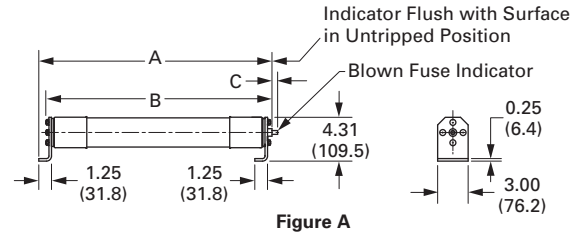

Figure A

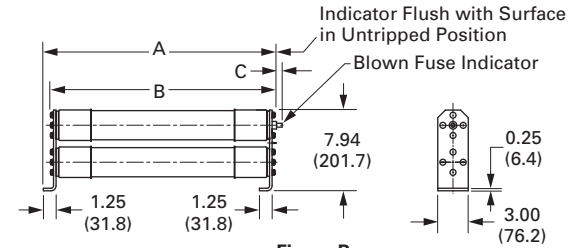

Figure B

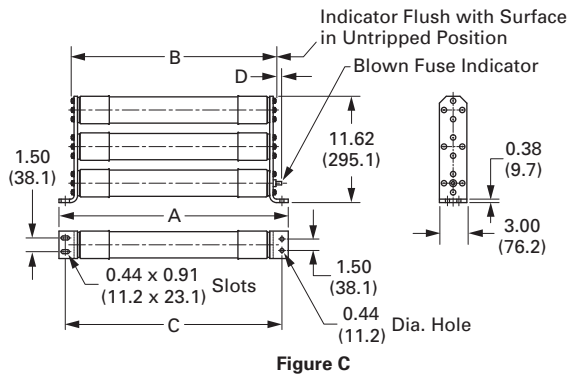
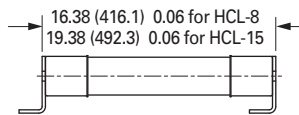

Figure C

HCL Type Fuse



Note

① 0.5 (12.7) tripped force 2 lb (0.9 kg).

3.4

Current Limiting Fuses

CLE, HLE, LHLE, AHLE, BHLE, HCL and BHCL Type Fuses

Mounting Details

Approximate Dimensions in Inches (mm)

CLE and HLE Type Disconnect Type Mountings

3

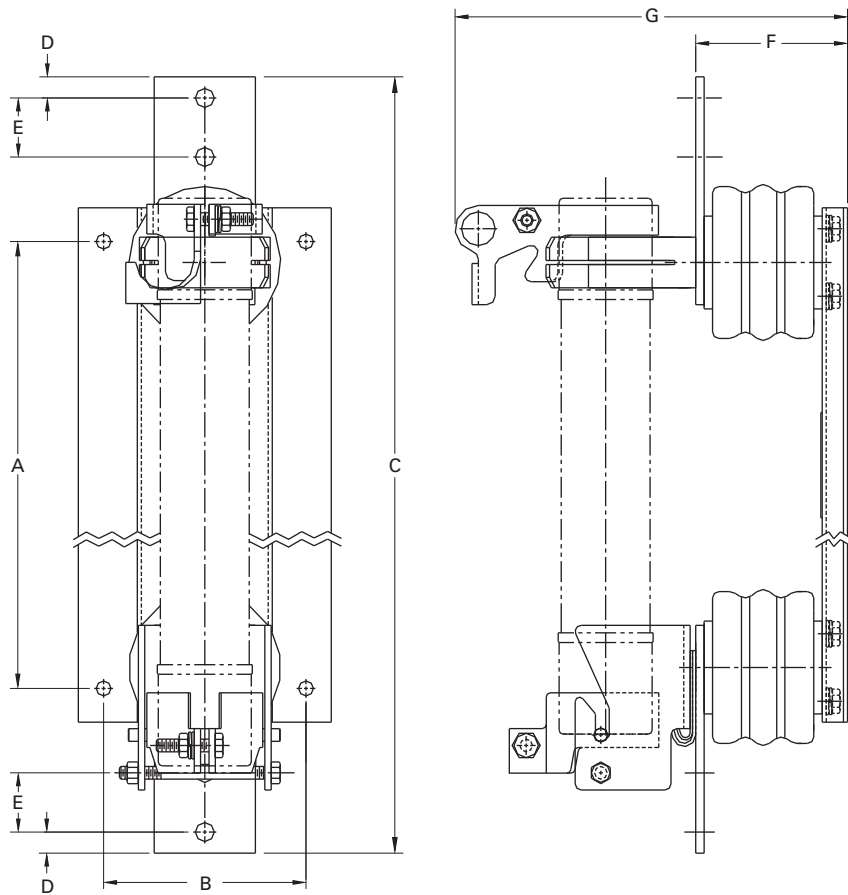

Approximate Dimensions in Inches (mm)

CLE and HLE Type Disconnect Mounting—Single

Catalog Number	Hole Centers A	Hole Centers B	Overall Length C	Hole Inset D	Hole Centers E	Contact Height F	Overall Height G	BIL Rating
2CLE-GDM-C	9.37 (238.0)	6.00 (152.4)	22.13 (562.1)	0.75 (19.0)	1.75 (44.4)	4.50 (114.3)	9.75 (247.6)	60
2CLE-GDM-D	8.24 (209.3)	6.00 (152.4)	18.00 (457.2)	0.62 (15.7)	1.75 (44.4)	4.50 (114.3)	11.72 (297.7)	60
2CLE-PDM-C	9.37 (238.0)	6.00 (152.4)	22.13 (562.1)	0.75 (19.0)	1.75 (44.4)	4.50 (114.3)	9.75 (247.6)	60
2CLE-PDM-D	8.24 (209.3)	6.00 (152.4)	18.00 (457.2)	0.62 (15.7)	1.75 (44.4)	4.50 (114.3)	11.72 (297.7)	60
5CLE-GDM-C	12.74 (323.6)	6.00 (152.4)	25.50 (647.7)	0.75 (19.0)	1.75 (44.4)	4.50 (114.3)	9.75 (247.6)	60
5CLE-PDM-C	12.74 (323.6)	6.00 (152.4)	25.50 (647.7)	0.75 (19.0)	1.75 (44.4)	4.50 (114.3)	9.75 (247.6)	60
5CLE-GDM-D	15.24 (387.1)	6.00 (152.4)	25.00 (647.7)	0.62 (15.7)	1.75 (44.4)	4.50 (114.3)	11.72 (297.7)	60
5CLE-PDM-D	15.24 (387.1)	6.00 (152.4)	25.00 (647.7)	0.62 (15.7)	1.75 (44.4)	4.50 (114.3)	11.72 (297.7)	60
5HLE-GDM-D	16.25 (412.8)	6.00 (152.4)	23.00 (584.2)	0.62 (15.7)	1.75 (44.4)	4.50 (114.3)	11.72 (297.7)	60
5HLE-PDM-D	16.25 (412.8)	6.00 (152.4)	23.00 (584.2)	0.62 (15.7)	1.75 (44.4)	4.50 (114.3)	11.72 (297.7)	60
8CLE-GDM-C	15.24 (387.1)	6.00 (152.4)	28.00 (711.2)	0.75 (19.0)	1.75 (44.4)	7.00 (177.8)	12.37 (314.2)	75
8CLE-GDM-D	15.24 (387.1)	6.00 (152.4)	25.00 (647.7)	0.62 (15.7)	1.75 (44.4)	7.00 (177.8)	14.22 (361.2)	75
8CLE-PDM-C	15.24 (387.1)	6.00 (152.4)	28.00 (711.2)	0.75 (19.0)	1.75 (44.4)	7.00 (177.8)	12.37 (314.2)	75
8CLE-PDM-D	15.24 (387.1)	6.00 (152.4)	25.00 (647.7)	0.62 (15.7)	1.75 (44.4)	7.00 (177.8)	14.22 (361.2)	75
8HLE-GDM-D	16.25 (412.8)	6.00 (152.4)	23.00 (584.2)	0.62 (15.7)	1.75 (44.4)	7.00 (177.8)	11.72 (297.7)	75
8HLE-PDM-D	16.25 (412.8)	6.00 (152.4)	23.00 (584.2)	0.62 (15.7)	1.75 (44.4)	7.00 (177.8)	11.72 (297.7)	75
15CLE-GDM-C	21.24 (539.5)	6.00 (152.4)	34.00 (863.6)	0.75 (19.0)	1.75 (44.4)	7.00 (177.8)	12.37 (314.2)	95
15CLE-GDM-D	21.15 (537.2)	6.00 (152.4)	31.00 (787.4)	0.62 (15.7)	1.75 (44.4)	7.00 (177.8)	14.22 (361.2)	95
15CLE-PDM-C	21.24 (539.5)	6.00 (152.4)	34.00 (863.6)	0.75 (19.0)	1.75 (44.4)	7.00 (177.8)	12.37 (314.2)	95
15CLE-PDM-D	21.15 (537.2)	6.00 (152.4)	31.00 (787.4)	0.62 (15.7)	1.75 (44.4)	7.00 (177.8)	14.22 (361.2)	95
15CLE-HPDM-C	21.24 (539.5)	6.00 (152.4)	34.00 (863.6)	0.75 (19.0)	1.75 (44.4)	8.50 (215.9)	13.87 (352.3)	110
15CLE-HPDM-D	21.15 (537.2)	6.00 (152.4)	31.00 (787.4)	0.62 (15.7)	1.75 (44.4)	8.50 (215.9)	13.87 (352.3)	110
15HLE-GDM-D	16.25 (412.8)	6.00 (152.4)	25.00 (647.7)	0.62 (15.7)	1.75 (44.4)	7.00 (177.8)	14.22 (361.2)	95
15HLE-PDM-D	16.25 (412.8)	6.00 (152.4)	25.00 (647.7)	0.62 (15.7)	1.75 (44.4)	7.00 (177.8)	14.22 (361.2)	95

CLE and HLE Type Non-Disconnect Mounting—Double

Catalog Number	Hole Centers A	Hole Centers B	Overall Length C	Hole Inset D	Hole Centers E	Contact Height F	Overall Height G	BIL Rating
2CLE-GDM-E	8.24 (209.3)	6.00 (152.4)	18.00 (457.2)	0.62 (15.7)	1.75 (44.4)	4.50 (114.3)	15.28 (388.1)	60
2CLE-PDM-E	8.24 (209.3)	6.00 (152.4)	18.00 (457.2)	0.62 (15.7)	1.75 (44.4)	4.50 (114.3)	15.28 (388.1)	60
5CLE-GDM-E	15.24 (387.1)	6.00 (152.4)	25.00 (647.7)	0.62 (15.7)	1.75 (44.4)	4.50 (114.3)	15.28 (388.1)	60
5CLS-PDM-E	15.24 (387.1)	6.00 (152.4)	25.00 (647.7)	0.62 (15.7)	1.75 (44.4)	4.50 (114.3)	15.28 (388.1)	60
5HLE-GDM-E	16.25 (412.8)	6.00 (152.4)	23.00 (584.2)	0.62 (15.7)	1.75 (44.4)	4.50 (114.3)	15.28 (388.1)	60
5HLE-PDM-E	16.25 (412.8)	6.00 (152.4)	23.00 (584.2)	0.62 (15.7)	1.75 (44.4)	4.50 (114.3)	15.28 (388.1)	60
8CLE-GDM-E	15.24 (387.1)	6.00 (152.4)	25.00 (647.7)	0.62 (15.7)	1.75 (44.4)	7.00 (177.8)	17.78 (451.6)	75
8CLE-PDM-E	15.24 (387.1)	6.00 (152.4)	25.00 (647.7)	0.62 (15.7)	1.75 (44.4)	7.00 (177.8)	17.78 (451.6)	75
8HLE-GDM-E	16.25 (412.8)	6.00 (152.4)	23.00 (584.2)	0.62 (15.7)	1.75 (44.4)	7.00 (177.8)	17.78 (451.6)	75
8HLE-PDM-E	16.25 (412.8)	6.00 (152.4)	23.00 (584.2)	0.62 (15.7)	1.75 (44.4)	7.00 (177.8)	17.78 (451.6)	75
15CLE-PDM-E	21.15 (537.2)	6.00 (152.4)	31.00 (787.4)	0.62 (15.7)	1.75 (44.4)	8.50 (215.9)	19.28 (489.7)	95
15HLE-GDM-E	16.25 (412.8)	6.00 (152.4)	26.00 (660.4)	0.62 (15.7)	1.75 (44.4)	7.00 (177.8)	17.78 (451.6)	95
15HLE-PDM-E	16.25 (412.8)	6.00 (152.4)	26.00 (660.4)	0.62 (15.7)	1.75 (44.4)	7.00 (177.8)	17.78 (451.6)	95

3.4

Current Limiting Fuses

CLE, HLE, LHLE, AHLE, BHLE, HCL and BHCL Type Fuses

Approximate Dimensions in Inches (mm)

CLE and HLE Type Non-Disconnect Mountings

3

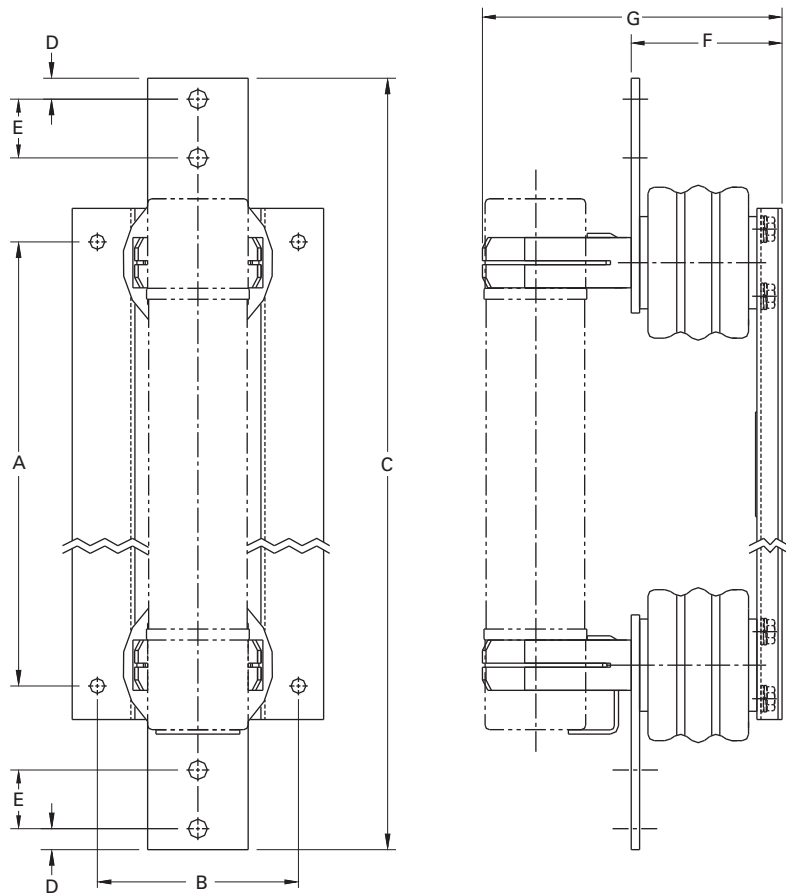

CLE, HLE, LHLE, AHLE, BHLE, HCL and BHCL Type Fuses

Approximate Dimensions in Inches (mm)

CLE and HLE Type Non-Disconnect Mounting—Single

Catalog Number	Hole Centers A	Hole Centers B	Overall Length C	Hole Inset D	Hole Centers E	Contact Height F	Overall Height G	BIL Rating
2CLE-GNM-C	9.37 (238.0)	6.00 (152.4)	18.63 (473.2)	0.75 (19.0)	1.75 (44.4)	4.50 (114.3)	7.25 (184.1)	60
2CLE-PNM-C	9.37 (238.0)	6.00 (152.4)	18.63 (473.2)	0.75 (19.0)	1.75 (44.4)	4.50 (114.3)	7.25 (184.1)	60
2CLE-GNM-D	8.24 (209.3)	6.00 (152.4)	18.00 (457.2)	0.62 (15.7)	1.75 (44.4)	4.50 (114.3)	8.79 (223.3)	60
2CLE-PNM-D	8.24 (209.3)	6.00 (152.4)	18.00 (457.2)	0.62 (15.7)	1.75 (44.4)	4.50 (114.3)	8.79 (223.3)	60
5CLE-GNM-C	12.75 (323.8)	6.00 (152.4)	22.00 (558.8)	0.75 (19.0)	1.75 (44.4)	4.50 (114.3)	7.25 (184.1)	60
5CLE-PNM-C	12.75 (323.8)	6.00 (152.4)	22.00 (558.8)	0.75 (19.0)	1.75 (44.4)	4.50 (114.3)	7.25 (184.1)	60
5CLE-GNM-D	15.24 (387.1)	6.00 (152.4)	25.00 (635.0)	0.62 (15.7)	1.75 (44.4)	4.50 (114.3)	8.79 (223.3)	60
5CLE-PNM-D	15.24 (387.1)	6.00 (152.4)	25.00 (635.0)	0.62 (15.7)	1.75 (44.4)	4.50 (114.3)	8.79 (223.3)	60
5HLE-GNM-D	16.25 (412.7)	6.00 (152.4)	23.00 (584.2)	0.62 (15.7)	1.75 (44.4)	4.50 (114.3)	8.79 (223.3)	60
15HLE-PNM-D	16.25 (412.7)	6.00 (152.4)	23.00 (584.2)	0.62 (15.7)	1.75 (44.4)	4.50 (114.3)	8.79 (223.3)	60
8CLE-GNM-C	15.25 (387.3)	6.00 (152.4)	24.50 (622.3)	0.75 (19.0)	1.75 (44.4)	7.00 (177.8)	9.75 (247.6)	75
8CLE-PNM-C	15.25 (387.3)	6.00 (152.4)	24.50 (622.3)	0.75 (19.0)	1.75 (44.4)	7.00 (177.8)	9.75 (247.6)	75
8CLE-PNM-D	15.25 (387.3)	6.00 (152.4)	25.00 (635.0)	0.62 (15.7)	1.75 (44.4)	7.00 (177.8)	11.29 (286.7)	75
8CLE-PNM-D	15.25 (387.3)	6.00 (152.4)	25.00 (635.0)	0.62 (15.7)	1.75 (44.4)	7.00 (177.8)	11.29 (286.7)	75
8HLE-GNM-D	16.25 (412.7)	6.00 (152.4)	23.00 (584.2)	0.62 (15.7)	1.75 (44.4)	7.00 (177.8)	11.29 (286.7)	75
8HLE-PNM-D	16.25 (412.7)	6.00 (152.4)	23.00 (584.2)	0.62 (15.7)	1.75 (44.4)	7.00 (177.8)	11.29 (286.7)	75
15CLE-GNM-C	21.25 (539.7)	6.00 (152.4)	30.50 (774.7)	0.75 (19.0)	1.75 (44.4)	7.00 (177.8)	9.75 (247.6)	95
15CLE-PNM-C	21.25 (539.7)	6.00 (152.4)	30.50 (774.7)	0.75 (19.0)	1.75 (44.4)	7.00 (177.8)	9.75 (247.6)	95
15CLE-HPMN-C	21.25 (539.7)	6.00 (152.4)	30.50 (774.7)	0.75 (19.0)	1.75 (44.4)	8.50 (215.9)	11.25 (285.7)	110
15CLE-GNM-D	21.15 (539.7)	6.00 (152.4)	31.00 (787.4)	0.62 (15.7)	1.75 (44.4)	7.00 (177.8)	11.29 (286.7)	95
15CLE-PNM-D	21.15 (539.7)	6.00 (152.4)	31.00 (787.4)	0.62 (15.7)	1.75 (44.4)	7.00 (177.8)	11.29 (286.7)	95
15CLE-HPNM-D	21.15 (539.7)	6.00 (152.4)	31.00 (787.4)	0.62 (15.7)	1.75 (44.4)	8.50 (215.9)	12.79 (286.7)	110
15HLE-GNM-D	16.25 (412.7)	6.00 (152.4)	26.00 (660.4)	0.62 (15.7)	1.75 (44.4)	7.00 (177.8)	11.29 (286.7)	95
15HLE-PNM-D	16.25 (412.7)	6.00 (152.4)	26.00 (660.4)	0.62 (15.7)	1.75 (44.4)	7.00 (177.8)	11.29 (286.7)	95

CLE and HLE Type Non-Disconnect Mounting—Double

Catalog Number	Hole Centers A	Hole Centers B	Overall Length C	Hole Inset D	Hole Centers E	Contact Height F	Overall Height G	BIL Rating
2CLE-GNM-E	8.24 (209.3)	6.00 (152.4)	18.00 (457.2)	0.62 (15.7)	1.75 (44.4)	4.50 (114.3)	12.48 (317.0)	60
2CLE-PNM-E	8.24 (209.3)	6.00 (152.4)	18.00 (457.2)	0.62 (15.7)	1.75 (44.4)	4.50 (114.3)	12.48 (317.0)	60
5CLE-GNM-E	15.24 (387.1)	6.00 (152.4)	25.00 (635.0)	0.62 (15.7)	1.75 (44.4)	4.50 (114.3)	12.48 (317.0)	60
5HLE-PNM-E	15.24 (387.1)	6.00 (152.4)	25.00 (635.0)	0.62 (15.7)	1.75 (44.4)	4.50 (114.3)	12.48 (317.0)	60
5HLE-GNM-E	16.25 (412.7)	6.00 (152.4)	23.00 (584.2)	0.62 (15.7)	1.75 (44.4)	4.50 (114.3)	12.48 (317.0)	60
5HLE-PNM-E	16.25 (412.7)	6.00 (152.4)	23.00 (584.2)	0.62 (15.7)	1.75 (44.4)	4.50 (114.3)	12.48 (317.0)	60
8CLE-GNM-E	15.24 (387.1)	6.00 (152.4)	25.00 (635.0)	0.62 (15.7)	1.75 (44.4)	7.00 (177.8)	14.98 (380.5)	75
8CLE-PNM-E	15.24 (387.1)	6.00 (152.4)	25.00 (635.0)	0.62 (15.7)	1.75 (44.4)	7.00 (177.8)	14.98 (380.5)	75
8HLE-GNM-E	16.25 (412.7)	6.00 (152.4)	23.00 (584.2)	0.62 (15.7)	1.75 (44.4)	7.00 (177.8)	14.98 (380.5)	75
8HLE-PNM-E	16.25 (412.7)	6.00 (152.4)	23.00 (584.2)	0.62 (15.7)	1.75 (44.4)	7.00 (177.8)	14.98 (380.5)	75
15CLE-PNM-E	21.15 (539.7)	6.00 (152.4)	31.00 (787.4)	0.62 (15.7)	1.75 (44.4)	8.50 (215.9)	16.48 (418.5)	95
15HLE-GNM-E	16.25 (412.7)	6.00 (152.4)	26.00 (660.4)	0.62 (15.7)	1.75 (44.4)	7.00 (177.8)	14.98 (380.5)	95
15HLE-PNM-E	16.25 (412.7)	6.00 (152.4)	26.00 (660.4)	0.62 (15.7)	1.75 (44.4)	7.00 (177.8)	14.98 (380.5)	95

(N)CLPT Fuses



CLPT and NCLPT Type Fuses

Product Description

Eaton CLPT (indicating) and NCLPT (non-indicating) fuses are applied wherever it is necessary to limit the short-circuit currents on control transformer and potential transformer circuits in high capacity systems in industrial installations and commercial buildings.

Current ratings from 1/2E to 10E are available at 2.4 kV to 34.5 kV.

Features

CLPT and NCLPT type current limiting fuses offer a number of desirable advantages. Consider the following during the selection process:

- **Quiet Safe Operation:** These fuses are designed for silent operation and elimination of flame discharges when the fuse operates
- **Identification of Blown Fuse:** These fuses are available in indicating and non-indicating versions. Indicators protrude from indicating type fuses providing a visual indication of a blown fuse

- **Space Economy:** Because the fuse is designed to eliminate flame and gas discharges, no exhaust control devices, flame boxes, vents or reinforcing are required
- **Complete Protection Provided:** Current limiting fuses provide positive interruption even on low fault currents. The fuse limits the magnitude of electromechanical stresses in the apparatus to be protected
- **Mountings:** Disconnect and non-disconnect mountings are available for most types of fuses from 5 kV through 15 kV. Live parts are available for 23 kV and 34.5 kV fuses
- **Dimensions:** Various fuse sizes are available for a wide range of applications

Construction

CLPT type current limiting fuses are basically constructed in a similar fashion to other Eaton current limiting fuses.

Contents

Description

	<i>Page</i>
CLPT and NCLPT Type Fuses	
Catalog Number Selection	V14-T3-43
Product Selection	V14-T3-43
Mounting Details	V14-T3-48

Ratings and Selection

When a decision has been made to use current limiting fuses, the minimum amount of information required to make the proper selection is:

- Voltage rating
- Current rating
- Interrupting rating
- Mounting method
 - Non-disconnect mounting
 - Disconnect mounting
 - Live parts only
 - No required mounting

Refer to tables on **Pages V14-T3-43 to V14-T3-49** for assistance in selecting the correct fuse catalog number.

These types of fuses are used in conjunction with potential and control power transformers. There are specific rules governing the selection of the required fuse continuous rating. The current limiting fuse application notes earlier in this publication offer additional information about this type of application.

When selecting the appropriate fuse for a new installation, keep in mind that one fuse unit and one compatible mounting may be required for each phase.

Catalog Number Selection

CLPT Fuse Units

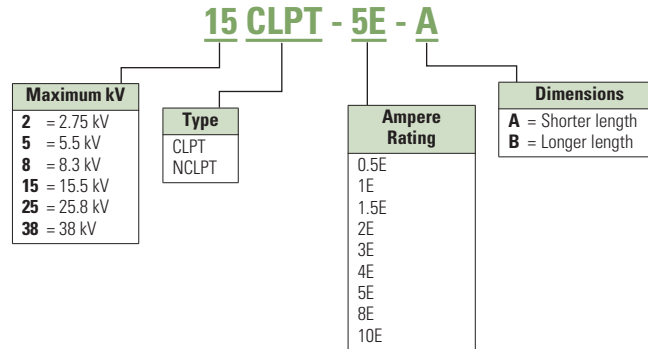

CLPT Mounting

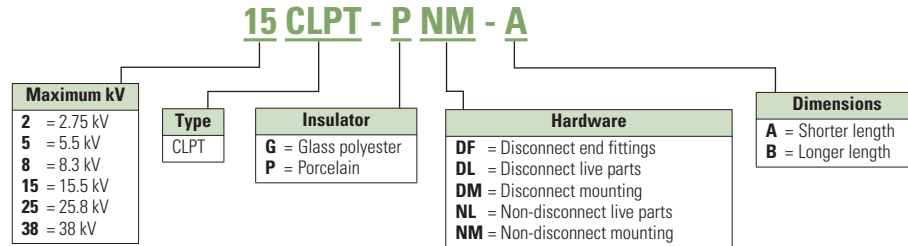

Product Selection

CLPT Type

Indicating



CLPT Type Current Limiting Fuses 2.475 kV Maximum (2.4 kV Nominal)

Current Rating (Amperes)	Interrupting Rating rms (kA Sym.)	Diameter	Clip Center	Length	Approximate Shipping Weight Lbs (kg)	Performance Curves			Catalog Number
						Minimum Melting Time	Total Clearing Time	Peak Let-Through Current	
0.25E	63	0.81 (20.6)	—	4.50 (114.3)	0.25 (0.11)	TC56357202	TC59883702	TC63933702	2NCLPT-.25E
0.5E	63	0.81 (20.6)	—	4.50 (114.3)	0.25 (0.11)	TC56357202	TC59883702	TC63933702	2NCLPT-.5E
1E	40	0.81 (20.6)	—	4.50 (114.3)	0.25 (0.11)	TC56357202	TC59883702	TC63933702	2NCLPT-1E
2E	40	0.81 (20.6)	—	4.50 (114.3)	0.25 (0.11)	TC56357202	TC59883702	TC63933702	2NCLPT-2E
5E	25	0.81 (20.6)	—	4.50 (114.3)	0.25 (0.11)	TC56357202	TC59883702	TC63933702	2NCLPT-5E

CLPT Type Current Limiting Fuses 5.5 kV Maximum (4.8 kV Nominal)

3

Non-Indicating



Current Rating (Amperes)	Interrupting Rating rms (kA Sym.)	Diameter	Clip Center	Length	Approximate Shipping Weight Lbs (kg)	Performance Curves		Peak Let-Through Current	Catalog Number
						Minimum Melting Time	Total Clearing Time		
Approximate Dimensions in Inches (mm)									
Non-Indicating									
0.5E	63	0.81 (20.6)	—	5.63 (143.0)	0.25 (0.11)	TC66702402	TC66702502	TC66704101	5NCLPT-.5E
1E	63	0.81 (20.6)	—	5.63 (143.0)	0.25 (0.11)	TC66702402	TC66702502	TC66704101	5NCLPT-1E
2E	63	0.81 (20.6)	—	5.63 (143.0)	0.25 (0.11)	TC66702402	TC66702502	TC66704101	5NCLPT-2E
3E	63	0.81 (20.6)	—	5.63 (143.0)	0.25 (0.11)	TC66702402	TC66702502	TC66704101	5NCLPT-3E
4E	63	0.81 (20.6)	—	5.63 (143.0)	0.25 (0.11)	TC66702402	TC66702502	TC66704101	5NCLPT-4E
5E	63	0.81 (20.6)	—	5.63 (143.0)	0.25 (0.11)	TC66702402	TC66702502	TC66704101	5NCLPT-5E
0.5E	50	1.00 (25.4)	—	5.63 (143.0)	0.25 (0.11)	TC66702402	TC66702502	TC66704101	317B487H02
1E	50	1.00 (25.4)	—	5.63 (143.0)	0.25 (0.11)	TC66702402	TC66702502	TC66704101	317B487H06
2E	50	1.00 (25.4)	—	5.63 (143.0)	0.25 (0.11)	TC66702402	TC66702502	TC66704101	317B487H03
3E	50	1.00 (25.4)	—	5.63 (143.0)	0.25 (0.11)	TC66702402	TC66702502	TC66704101	317B487H04
5E	50	1.00 (25.4)	—	5.63 (143.0)	0.25 (0.11)	TC66702402	TC66702502	TC66704101	317B487H05
0.5E	63	1.60 (40.6)	8.10 (205.7)	9.50 (241.3)	1.2 (0.54)	TC70548302	TC70548402	TC63934002	5NCLPT-.5E-A
1E	63	1.60 (40.6)	8.10 (205.7)	9.50 (241.3)	1.2 (0.54)	TC70548302	TC70548402	TC63934002	5NCLPT-1E-A
2E	63	1.60 (40.6)	8.10 (205.7)	9.50 (241.3)	1.2 (0.54)	TC70548302	TC70548402	TC63934002	5NCLPT-2E-A
3E	63	1.60 (40.6)	8.10 (205.7)	9.50 (241.3)	1.2 (0.54)	TC70548302	TC70548402	TC63934002	5NCLPT-3E-A
5E	63	1.60 (40.6)	8.10 (205.7)	9.50 (241.3)	1.2 (0.54)	TC70548302	TC70548402	TC63934002	5NCLPT-5E-A
10E	63	1.60 (40.6)	8.10 (205.7)	9.50 (241.3)	1.2 (0.54)	TC70548302	TC70548402	TC63934002	5NCLPT-10E-A

Indicating



Indicating									
0.5E	80	1.60 (40.6)	8.10 (205.7)	9.50 (241.3)	1.2 (0.54)	TC56353206	TC56353306	TC63934001	5CLPT-.5E
1E	80	1.60 (40.6)	8.10 (205.7)	9.50 (241.3)	1.2 (0.54)	TC56353206	TC56353306	TC63934001	5CLPT-1E
1.5E	80	1.60 (40.6)	8.10 (205.7)	9.50 (241.3)	1.2 (0.54)	TC56353206	TC56353306	TC63934001	5CLPT-1.5E
3E	80	1.60 (40.6)	8.10 (205.7)	9.50 (241.3)	1.2 (0.54)	TC56353206	TC56353306	TC63934001	5CLPT-3E
5E	80	1.60 (40.6)	8.10 (205.7)	9.50 (241.3)	1.2 (0.54)	TC56353206	TC56353306	TC63934001	5CLPT-5E
10E	80	1.60 (40.6)	8.10 (205.7)	9.50 (241.3)	1.2 (0.54)	TC56353206	TC56353306	TC63934001	5CLPT-10E

CLPT Type Mountings and Hardware 5.5 kV Maximum (4.8 kV Nominal) ①

Ampere Rating	Fuse Mounting Type ②	Voltage BIL (kV)	Mounting (Including Live Parts, End Fittings) ③		Live Parts (Including End Fittings) ③	End Fittings (Disconnect Only)
			Porcelain Insulator Catalog Number	Glass-Polyester Insulator Catalog Number		
0.5–2	Non-disconnect	60	5CLPT-PNM-A	5CLPT-GNM-A	CLPT-NL	—
	Disconnect	60	5CLPT-PDM-A	5CLPT-GDM-A	CLPT-DL	CLPT-DF
3–10	Non-disconnect	60	5CLPT-PNM-B	5CLPT-GNM-B	CLPT-NL	—
	Disconnect	60	5CLPT-PDM-B	5CLPT-GDM-B	CLPT-DL	CLPT-DF

Notes

- ① Refers only to 5CLPT and 5NCLPT-A fuses only.
- ② See Page V14-T3-38 for diagram of typical mounting.
- ③ End fittings supplied only when required.

CLPT Type Current Limiting Fuses 8.3 kV Maximum (7.2 kV Nominal)

Current Rating (Amperes)	Interrupting Rating rms (kA Sym.)	Diameter	Clip Center	Length	Approximate Shipping Weight Lbs (kg)	Performance Curves		Peak Let-Through Current	Catalog Number
						Minimum Melting Time	Total Clearing Time		
Non-Indicating									
2E	25	0.81 (20.6)	—	8.00 (203.2)	0.25 (0.11)	TC56357206	TC59883706	TC63933704	8NCLPT-2E
4E	25	0.81 (20.6)	—	8.00 (203.2)	0.25 (0.11)	TC56357206	TC59883706	TC63933704	8NCLPT-4E
10E	50	1.10 (27.9)	—	5.00 (127.0)	0.5 (0.23)	TC56357206	TC59883706	TC63933704	8NCLPT-0E
1E	50	1.10 (27.9)	—	5.00 (127.0)	0.5 (0.23)	TC56357206	TC59883706	TC63933704	8NCLPT-1E
5E	50	1.10 (27.9)	—	5.00 (127.0)	0.5 (0.23)	TC56357206	TC59883706	TC63933704	8NCLPT-5E
0.5E	50	1.60 (40.6)	8.10 (205.7)	9.50 (241.3)	1.5 (0.70)	TC70548303	TC70548403	TC63934002	8NCLPT-.5E-A
1E	50	1.60 (40.6)	8.10 (205.7)	9.50 (241.3)	1.5 (0.70)	TC70548303	TC70548403	TC63934002	8NCLPT-1E-A
2E	50	1.60 (40.6)	8.10 (205.7)	9.50 (241.3)	1.5 (0.70)	TC70548303	TC70548403	TC63934002	8NCLPT-2E-A
3E	50	1.60 (40.6)	8.10 (205.7)	9.50 (241.3)	1.5 (0.70)	TC70548303	TC70548403	TC63934002	8NCLPT-3E-B
5E	50	1.60 (40.6)	11.50 (292.1)	12.90 (327.7)	1.6 (0.73)	TC70548303	TC70548403	TC63934002	8NCLPT-5E-B
10E	50	1.60 (40.6)	11.50 (292.1)	12.90 (327.7)	1.6 (0.73)	TC70548303	TC70548403	TC63934002	8NCLPT-10E-B
Indicating									
.5E	80	1.60 (40.6)	8.10 (205.7)	9.50 (241.3)	1.5 (0.70)	TC56353206	TC56353306	TC63934001	8CLPT-.5E
3E	80	1.60 (40.6)	8.10 (205.7)	9.50 (241.3)	1.6 (0.73)	TC56353206	TC56353306	TC63934001	8CLPT-3E
5E	50	1.60 (40.6)	8.10 (205.7)	9.50 (241.3)	1.6 (0.73)	TC56353206	TC56353306	TC63934001	8CLPT-5E
10E	50	1.60 (40.6)	8.10 (205.7)	9.50 (241.3)	1.6 (0.73)	TC56353206	TC56353306	TC63934001	8CLPT-10E

CLPT Type Mountings and Hardware 8.3 kV Maximum (7.2 kV Nominal) ①

Ampere Rating	Fuse Mounting Type ②	Voltage BIL (kV)	Mounting (Including Live Parts, End Fittings) ③		Live Parts (Including End Fittings) ③	End Fittings (Disconnect Only)
			Porcelain Insulator Catalog Number	Glass-Polyester Insulator Catalog Number		
0.5–2	Non-disconnect	75	8CLPT-PNM-A	8CLPT-GNM-A	CLPT-NL	—
	Disconnect	75	8CLPT-PDM-A	8CLPT-GDM-A	CLPT-DL	CLPT-DF
3–10	Non-disconnect	75	8CLPT-PNM-B	8CLPT-GNM-B	CLPT-NL	—
	Disconnect	75	8CLPT-PDM-B	8CLPT-GDM-B	CLPT-DL	CLPT-DF

Notes

- ① Refers only to 8CLPT and 8NCLPT-A or -B fuses only.
- ② See **Page V14-T3-38** for diagram of typical mounting.
- ③ End fittings supplied only when required.

3.5

Current Limiting Fuses

CLPT and NCLPT Type Fuses

CLPT Type Current Limiting Fuses 15.5 kV Maximum (7.2 kV Nominal)

Current Rating (Amperes)	Interrupting Rating rms (kA Sym.)	Diameter	Clip Center	Length	Approximate Shipping Weight Lbs (kg)	Performance Curves			Catalog Number
						Minimum Melting Time	Total Clearing Time	Peak Let-Through Current	
Approximate Dimensions in Inches (mm)									
Non-Indicating									
0.5E	63	1.60 (40.6)	11.50 (292.1)	12.90 (327.7)	1.6 (0.73)	TC70548303	TC70548403	TC63934002	15NCLPT-.5E
1E	63	1.60 (40.6)	11.50 (292.1)	12.90 (327.7)	1.6 (0.73)	TC70548303	TC70548403	TC63934002	15NCLPT-1E
2E	63	1.60 (40.6)	11.50 (292.1)	12.90 (327.7)	1.6 (0.73)	TC70548303	TC70548403	TC63934002	15NCLPT-1.5E
3E	63	1.60 (40.6)	16.10 (408.9)	17.60 (447.0)	2 (0.91)	TC70548303	TC70548403	TC63934002	15NCLPT-3E
5E	63	1.60 (40.6)	16.10 (408.9)	17.60 (447.0)	2 (0.91)	TC70548303	TC70548403	TC63934002	15NCLPT-5E
10E	63	1.60 (40.6)	16.10 (408.9)	17.60 (447.0)	2 (0.91)	TC70548303	TC70548403	TC63934002	15NCLPT-10E
Indicating									
0.5E	80	1.60 (40.6)	11.50 (292.1)	12.90 (327.7)	1.6 (0.73)	TC56353206	TC56353306	TC63934001	15CLPT-.5E
1E	80	1.60 (40.6)	11.50 (292.1)	12.90 (327.7)	1.6 (0.73)	TC56353206	TC56353306	TC63934001	15CLPT-1E
2E	80	1.60 (40.6)	11.50 (292.1)	12.90 (327.7)	1.6 (0.73)	TC56353206	TC56353306	TC63934001	15CLPT-1.5E
3E	80	1.60 (40.6)	16.10 (408.9)	17.60 (447.0)	2 (0.91)	TC56353206	TC56353306	TC63934001	15CLPT-3E
5E	80	1.60 (40.6)	16.10 (408.9)	17.60 (447.0)	2 (0.91)	TC56353206	TC56353306	TC63934001	15CLPT-5E
10E	50	1.60 (40.6)	16.10 (408.9)	17.60 (447.0)	2 (0.91)	TC56353206	TC56353306	TC63934001	15CLPT-10E

3 Non-Indicating



Indicating



CLPT Type Mountings and Hardware 15.5 kV Maximum (14.4 kV Nominal)

Ampere Rating	Fuse Mounting Type ①	Voltage BIL (kV)	Mounting (Including Live Parts, End Fittings) ②		Live Parts (Including End Fittings) ②	End Fittings (Disconnect Only)
			Porcelain Insulator Catalog Number	Glass-Polyester Insulator Catalog Number		
0.5–2	Non-disconnect	95	15CLPT-PNM-A	15CLPT-GNM-A	CLPT-NL	—
	Disconnect	95	15CLPT-PDM-A	15CLPT-GDM-A	CLPT-DL	CLPT-DF
3–10	Non-disconnect	95	15CLPT-PNM-B	15CLPT-GNM-B	CLPT-NL	CLPT-DF
	Disconnect	95	15CLPT-PDM-B	15CLPT-GDM-B	CLPT-DL	—

Notes

- ① See Page V14-T3-38 for diagram of typical mounting.
- ② End fittings supplied only when required.

CLPT Type Current Limiting Fuses 25.5 kV Maximum (23.0 kV Nominal)

Current Rating (Amperes)	Interrupting Rating rms (kA Sym.)	Diameter Approximate	Clip Center Dimensions in Inches (mm)	Length (mm)	Approximate Shipping Weight Lbs (kg)	Performance Curves			Catalog Number
						Minimum Melting Time	Total Clearing Time	Peak Let-Through Current	
0.5E	44	1.60 (40.6)	16.10 (408.9)	17.60 (447.0)	2 (0.91)	TC56353208	TC56353308	TC63933901	25CLPT-5E
1E	44	1.60 (40.6)	16.10 (408.9)	17.60 (447.0)	2 (0.91)	TC56353208	TC56353308	TC63933901	25CLPT-1E

CLPT Type Mountings and Hardware 25.5 kV Maximum (23.0 kV Nominal)

Ampere Rating	Fuse Mounting Type ^①	Voltage BIL (kV)	Mounting (Including Live Parts, End Fittings) ^②		Live Parts (Including End Fittings) ^②	End Fittings (Disconnect Only)
			Porcelain Insulator Catalog Number	Glass-Polyester Insulator Catalog Number		
0.5E-1E	Non-disconnect	150	25CLPT-PNM-A	—	25CLPT-NL	—
	Disconnect	150	25CLPT-PDM-A	—	25CLPT-DL	CLPT-DF

CLPT Type Current Limiting Fuses 38.0 kV Maximum (34.5 kV Nominal)

Current Rating (Amperes)	Interrupting Rating rms (kA Sym.)	Diameter Approximate	Clip Center Dimensions in Inches (mm)	Length (mm)	Approximate Shipping Weight Lbs (kg)	Performance Curves			Catalog Number
						Minimum Melting Time	Total Clearing Time	Peak Let-Through Current	
0.5E	44	1.60 (40.6)	17.10 (434.3)	18.60 (472.4)	2 (0.91)	TC56353208	TC56353308	TC63933901	38CLPT-5E

CLPT Type Mountings and Hardware 38.0 kV Maximum (34.5 kV Nominal)

Ampere Rating	Fuse Mounting Type ^①	Voltage BIL (kV)	Mounting (Including Live Parts, End Fittings) ^②		Live Parts (Including End Fittings) ^②	End Fittings (Disconnect Only)
			Porcelain Insulator Catalog Number	Glass-Polyester Insulator Catalog Number		
0.5E	Disconnect	—	Not applicable	Not applicable	25CLPT-NL	CLPT-DF
	Non-disconnect	—	Not applicable	Not applicable	25CLPT-DL	—

Notes

^① See Page V14-T3-38 for diagram of typical mounting.

^② End fittings supplied only when required.

3.5

Current Limiting Fuses

CLPT and NCLPT Type Fuses

Mounting Details

Approximate Dimensions in Inches (mm)

CLPT and NCLPT Type Disconnect Mountings

3

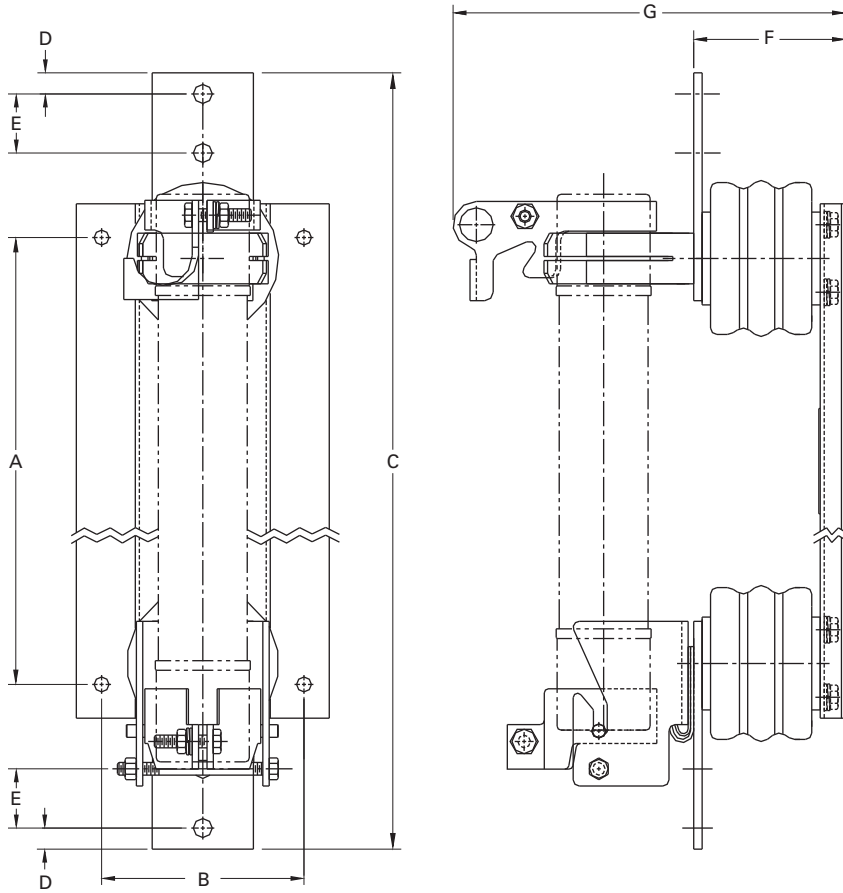

Catalog Number	Hole Centers A	Hole Centers B	Overall Length C	Hole Inset D	Hole Centers E	Contact Height F	Overall Height G	BIL Rating
5CLPT-GDM-A	9.37 (238.0)	6.00 (152.4)	18.63 (473.2)	0.75 (19.0)	1.75 (44.4)	4.50 (114.3)	9.56 (242.8)	60
5CLPT-PDM-A	9.37 (238.0)	6.00 (152.4)	18.63 (473.2)	0.75 (19.0)	1.75 (44.4)	4.50 (114.3)	9.56 (242.8)	60
8CLPT-GDM-A	9.37 (238.0)	6.00 (152.4)	18.63 (473.2)	0.75 (19.0)	1.75 (44.4)	7.00 (177.8)	12.06 (306.3)	75
8CLPT-GDM-B	9.37 (238.0)	6.00 (152.4)	18.63 (473.2)	0.75 (19.0)	1.75 (44.4)	7.00 (177.8)	12.06 (306.3)	75
8CLPT-PDM-A	12.74 (323.6)	6.00 (152.4)	22.00 (558.8)	0.75 (19.0)	1.75 (44.4)	7.00 (177.8)	12.06 (306.3)	75
8CLPT-PDM-B	12.74 (323.6)	6.00 (152.4)	22.00 (558.8)	0.75 (19.0)	1.75 (44.4)	7.00 (177.8)	12.06 (306.3)	75
15CLPT-GDM-A	12.74 (323.6)	6.00 (152.4)	22.00 (558.8)	0.75 (19.0)	1.75 (44.4)	7.00 (177.8)	12.06 (306.3)	95
15CLPT-PDM-A	12.74 (323.6)	6.00 (152.4)	22.00 (558.8)	0.75 (19.0)	1.75 (44.4)	7.00 (177.8)	12.06 (306.3)	95
15CLPT-GDM-B	17.46 (443.5)	6.00 (152.4)	26.63 (676.4)	0.75 (19.0)	1.75 (44.4)	7.00 (177.8)	12.06 (306.3)	95
15CLPT-PDM-B	17.46 (443.5)	6.00 (152.4)	26.63 (676.4)	0.75 (19.0)	1.75 (44.4)	7.00 (177.8)	12.06 (306.3)	95
15CLPY-HPDM-A	12.74 (323.6)	6.00 (152.4)	22.00 (558.8)	0.75 (19.0)	1.75 (44.4)	8.50 (215.9)	13.56 (344.4)	110
15CLPT-HPDM-B	17.46 (443.5)	6.00 (152.4)	26.63 (676.4)	0.75 (19.0)	1.75 (44.4)	8.50 (215.9)	13.56 (344.4)	110
25CLPT-PNM-A	19.12 (485.6)	7.00 (177.8)	26.63 (676.4)	0.75 (19.0)	1.75 (44.4)	12.00 (304.8)	17.06 (433.3)	150

Approximate Dimensions in Inches (mm)

CLPT and NCLPT Type Non-Disconnect Mountings

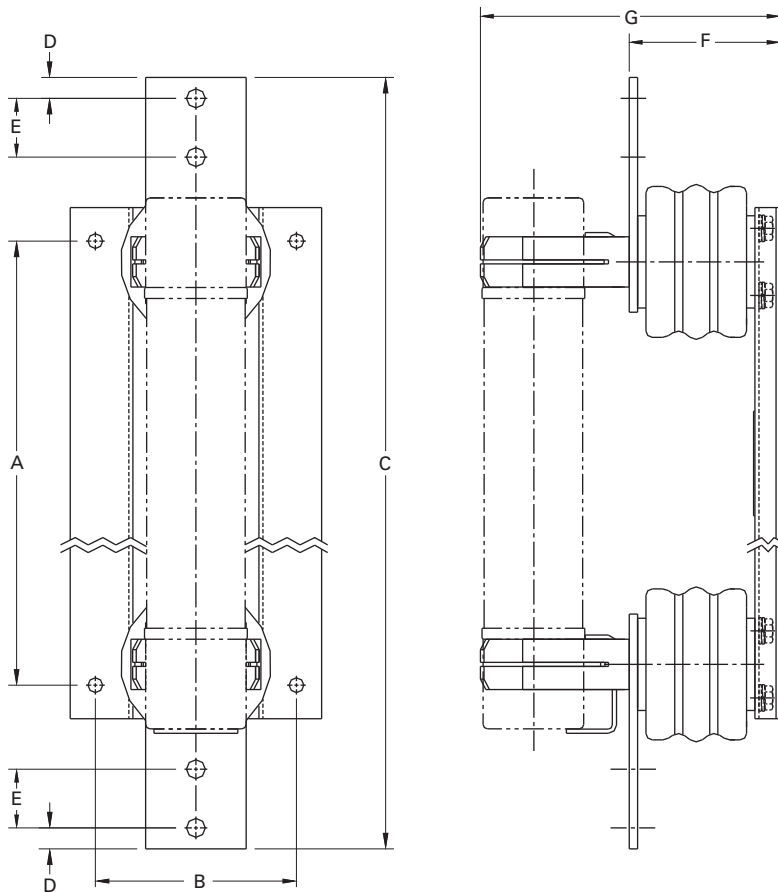

3

Catalog Number	Hole Centers A	Hole Centers B	Overall Length C	Hole Inset D	Hole Centers E	Contact Height F	Overall Height G	BIL Rating
5CLPT-GNM-A	9.37 (238.0)	6.00 (152.4)	18.63 (473.2)	0.75 (19.0)	1.75 (44.4)	4.50 (114.3)	6.94 (176.2)	60
5CLPT-PNM-A	9.37 (238.0)	6.00 (152.4)	18.63 (473.2)	0.75 (19.0)	1.75 (44.4)	4.50 (114.3)	6.94 (176.2)	60
8CLPT-GNM-A	9.37 (238.0)	6.00 (152.4)	18.63 (473.2)	0.75 (19.0)	1.75 (44.4)	7.00 (177.8)	9.44 (239.8)	75
8CLPT-PNM-A	9.37 (238.0)	6.00 (152.4)	18.63 (473.2)	0.75 (19.0)	1.75 (44.4)	7.00 (177.8)	9.44 (239.8)	75
8CLPT-GNM-B	12.75 (323.8)	6.00 (152.4)	22.00 (558.8)	0.75 (19.0)	1.75 (44.4)	7.00 (177.8)	9.44 (239.8)	75
8CLPT-PNM-B	12.75 (323.8)	6.00 (152.4)	22.00 (558.8)	0.75 (19.0)	1.75 (44.4)	7.00 (177.8)	9.44 (239.8)	75
15CLPT-GNM-A	12.74 (323.6)	6.00 (152.4)	22.00 (558.8)	0.75 (19.0)	1.75 (44.4)	7.00 (177.8)	9.44 (239.8)	95
15CLPT-PNM-A	12.74 (323.6)	6.00 (152.4)	22.00 (558.8)	0.75 (19.0)	1.75 (44.4)	7.00 (177.8)	9.44 (239.8)	95
15CLPT-HPNM-A	12.74 (323.6)	6.00 (152.4)	22.00 (558.8)	0.75 (19.0)	1.75 (44.4)	8.50 (215.9)	10.94 (277.9)	110
15CLPT-GNM-B	17.46 (443.5)	6.00 (152.4)	26.63 (676.4)	0.75 (19.0)	1.75 (44.4)	7.00 (177.8)	9.44 (239.8)	95
15CLPT-PNM-B	17.46 (443.5)	6.00 (152.4)	26.63 (676.4)	0.75 (19.0)	1.75 (44.4)	7.00 (177.8)	9.44 (239.8)	95
15CLPT-HPNM-B	17.46 (443.5)	6.00 (152.4)	26.63 (676.4)	0.75 (19.0)	1.75 (44.4)	8.50 (215.9)	10.94 (277.9)	110
25CLPT-PNM-A	19.12 (485.6)	7.00 (177.8)	26.63 (676.4)	0.75 (19.0)	1.75 (44.4)	12.00 (304.8)	14.43 (367.0)	150
38CLPT-PNM-A	19.12 (485.6)	7.00 (177.8)	26.63 (676.4)	0.75 (19.0)	1.75 (44.4)	12.00 (304.8)	14.43 (367.0)	150

3.6

Current Limiting Fuses

ACLS, BCLS, CLS, HCLS and NCLS Type Fuses

Motor Start Fuses



3

Contents

Description

Page

ACLS, BCLS, CLS, HCLS and NCLS Type Fuses	
UL Component Recognition	V14-T3-51
Ratings and Selection	V14-T3-51
Catalog Number Selection	V14-T3-51
Product Selection	V14-T3-59
Dimensions	V14-T3-63

ACLS, BCLS, CLS, HCLS and NCLS Type Fuses

Product Description

Eaton’s CLS current limiting fuses are used in conjunction with medium voltage motor starters to provide short-circuit protection for individual motor circuits.

Contactors in motor starting equipment protect the equipment from over-currents due to starting, stalling and plugging while current limiting fuses provide short-circuit protection only.

Duty cycles of fuses used in medium voltage motor starters are characterized by the frequent application of high overloads such as motor starting currents. Motor starter fuses, therefore, must be designed to withstand the consequent frequent severe heating and cooling cycles without fatigue failures. CLS type fuses have such a construction. The element designs used are not sensitive to low currents, and have “fatigue proof” features to provide highly uniform flexing of elements during heating cycles.

The mounting possibilities for CLS type current limiting fuses are shown on **Page V14-T3-64**, with disconnect type being the predominant approach.

CLS Features

CLS type current limiting fuses offer a number of advantages over a number of other designs. During the selection process, consider the following:

- **Quiet Safe Operation:** CLS type current limiting fuses are designed for silent operation and elimination of flame discharges when the fuse operates
- **Easy to Identify Operated Fuse:** CLS type current limiting fuses are equipped with an indicator that will protrude indicating when a fuse has operated
- **Space Economy:** Because the design of these fuses has eliminated flame or gas discharge, the need for exhaust control devices, vents and reinforcing is eliminated

- **Complete Protection Provided:** CLS type current limiting fuses ensure positive interruption of high fault currents. The fuse limits the magnitude of the electromechanical stresses in the protected apparatus. They also limit the arc voltage to considerably less than three times the nominal circuit voltage
- **Fatigue Proof:** Controlled “crimping” of the silver elements during fuse manufacture permits CLS type current limiting fuses to withstand severe duty cycling without failure

Construction

CLS type current limiting fuses are of basically inorganic construction. The only organic material used is a high temperature glass-resin outer casing and the plastic indicator. The fuse elements are pure silver and are crimped at controlled locations along the active length to increase the strength of the element, and to uniformly distribute mechanical expansion and prevent fatigue failure due to severe cycling duties. Element design combines maximum load carrying ability with the most favorable short circuit interruption characteristics. These fuses are filled with a high purity silica sand with controlled grain size.

UL® Component Recognition

Underwriters Laboratories has witnessed testing on and recognizes certain styles of 5CLS and 5ACLS fuses. These fuses carry the “reversed UR” designation. CLS type current limiting motor start fuses manufactured prior to 1975 were not identified by an “R” designation. However, these fuses can be used with or replaced by newer fuses with “R” designations as indicated below.

Ratings and Selection

When a decision has been made to use current limiting fuses, the minimum amount of information required to make the proper selection is:

- Voltage rating
- Current rating
- Interrupting rating
- Mounting method
 - Non-disconnect mounting
 - Disconnect mounting
 - Clip-lock mounting
 - Direct bolt-in mounting
 - Live parts only
 - No required mounting

Refer to **Pages V14-T3-52 to V14-T3-62** for assistance in selecting the correct fuse catalog number.

These types of fuses are used in conjunction with high voltage motor starters to provide short-circuit protection for individual motors. There are specific rules governing the selection of the required fuse continuous rating.

The current limiting fuse application notes earlier in this publication offer additional information about this type of application.

When selecting the appropriate fuse for a new installation, keep in mind that one fuse unit and one compatible mounting is required for each phase.

Catalog Number Selection

CLS Fuse Units

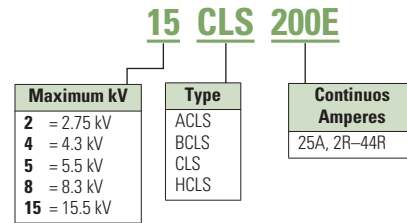

3.6

Current Limiting Fuses

ACLS, BCLS, CLS, HCLS and NCLS Type Fuses

CLS Type Current Limiting Fuses

Max. Design Voltage (kV)	Current Rating (A)	"R" Designation	Catalog Number	Barrel Number	Interrupting Rating rms (kA Sym.)	Diameter (Inches)	Clip Center (Inches)	Length (Inches)	Approx. Shipping Weight (Lbs)	Catalog Number		Performance Curves		
										Live Parts ①	End Fittings ②	Minimum Melting Time	Total Clearing Time	Peak Let-Through Current
2.54	25	—	2CLS-25	1	50	3	7	10.8	7	CLE-NL-D	—	TC66664702	TC66664704	TC66700202
	70	2R	2CLS-2R	1	50	3	7	10.8	7	CLE-DL-D	CLE-DF-D			
	100	3R	2CLS-3R	1	50	3	7	10.8	7					
	130	4R	2CLS-4R	1	50	3	7	10.8	7					
	150	5R	2CLS-5R	1	50	3	7	10.8	7					
	170	6R	2CLS-6R	1	50	3	7	10.8	7					
	200	9R	2CLS-9R	1	50	3	7	10.8	7					
	230	12R	2CLS-12R	1	50	3	7	10.8	7					
	390	18R	2CLS-18R	2	50	3	7	10.8	16	CLE-NL-E	—	TC66664702	TC66664704	TC66700202
	450	24R	2CLS-24R	2	50	3	7	10.8	16	CLE-DL-E	CLE-DF-E			
	25	—	2ACLS-25	1	50	3	—	10.8	7	—		TC66664702	TC66664704	TC66700202
	70	2R	2ACLS-2R	1	50	3	—	10.8	7					
	100	3R	2ACLS-3R	1	50	3	—	10.8	7					
	130	4R	2ACLS-4R	1	50	3	—	10.8	7					
	150	5R	2ACLS-5R	1	50	3	—	10.8	7					
	170	6R	2ACLS-6R	1	50	3	—	10.8	7					
	200	9R	2ACLS-9R	1	50	3	—	10.8	7					
	230	12R	2ACLS-12R	1	50	3	—	10.8	7					
	390	18R	2ACLS-18R	2	50	3	—	10.8	16					
	450	24R	2ACLS-24R	2	50	3	—	10.8	16					
25	—	2BCLS-25	1	50	3	—	—	8	—		TC66664702	TC66664704	TC66700202	
70	2R	2BCLS-2R	1	50	3	—	—	8						
100	3R	2BCLS-3R	1	50	3	—	—	8						
130	4R	2BCLS-4R	1	50	3	—	—	8						
150	5R	2BCLS-5R	1	50	3	—	—	8						
170	6R	2BCLS-6R	1	50	3	—	—	8						
200	9R	2BCLS-9R	1	50	3	—	—	8						
230	12R	2BCLS-12R	1	50	3	—	—	8						
390	18R	2BCLS-18R	2	50	3	—	—	17						
450	24R	2BCLS-24R	2	50	3	—	—	17						
25	—	2HCLS-25	1	50	3	—	10.8	7	—		TC66664702	TC66664704	TC66700202	
70	2R	2HCLS-2R	1	50	3	—	10.8	7						
100	3R	2HCLS-3R	1	50	3	—	10.8	7						
130	4R	2HCLS-4R	1	50	3	—	10.8	7						
150	5R	2HCLS-5R	1	50	3	—	10.8	7						
170	6R	2HCLS-6R	1	50	3	—	10.8	7						
200	9R	2HCLS-9R	1	50	3	—	10.8	7						
230	12R	2HCLS-12R	1	50	3	—	10.8	7						
390	18R	2HCLS-18R	2	50	3	—	10.8	16						
450	24R	2HCLS-24R	2	50	3	—	10.8	16						

Notes

- ① Includes end fittings.
- ② Disconnect only.

CLS Type Current Limiting Fuses, continued

Max. Design Voltage (kV)	Current Rating (A)	"R" Designation	Catalog Number	Barrel Number	Interrupting Rating rms (kA Sym.)	Diameter (Inches)	Clip Center (Inches)	Length (Inches)	Approx. Shipping Weight (Lbs)	Catalog Number		Performance Curves		
										Live Parts ①	End Fittings ②	Minimum Melting Time	Total Clearing Time	Peak Let-Through Current
5.5	30	—	5CLS-30	1	50	3	12	15.9	8	CLE-NL-D CLE-DL-D	— CLE-DF-D	TC66690602	TC66690702	TC66700203
	70	2R	5CLS-2R	1	50	3	12	15.9	8					
	100	3R	5CLS-3R	1	50	3	12	15.9	8					
	130	4R	5CLS-4R	1	50	3	12	15.9	8					
	150	5R	5CLS-5R	1	50	3	12	15.9	8					
	170	6R	5CLS-6R	1	50	3	12	15.9	8					
	200	9R	5CLS-9R	1	50	3	12	15.9	8					
	230	12R	5CLS-12R	1	50	3	12	15.9	8					
	390	18R	5CLS-18R	2	50	3	12	15.9	17					
	450	24R	5CLS-24R	2	50	3	12	15.9	17					
5.08	30	—	5ACLS-30	1	50	3	—	15.9	8	—	—	TC66690602	TC66690702	TC66700203
	70	2R	5ACLS-2R	1	50	3	—	15.9	8					
	100	3R	5ACLS-3R	1	50	3	—	15.9	8					
	130	4R	5ACLS-4R	1	50	3	—	15.9	8					
	150	5R	5ACLS-5R	1	50	3	—	15.9	8					
	170	6R	5ACLS-6R	1	50	3	—	15.9	8					
	200	9R	5ACLS-9R	1	50	3	—	15.9	8					
	230	12R	5ACLS-12R	1	50	3	—	15.9	8					
	390	18R	5ACLS-18R	2	50	3	—	15.9	17					
	450	24R	5ACLS-24R	2	50	3	—	15.9	17					
4.3	480	26R	4ACLS-26R	2	50	3	—	15.9	17					
5.08	30	—	5BCLS-30	1	50	3	—	—	8	—	—	TC66690602	TC66690702	TC66700203
	70	2R	5BCLS-2R	1	50	3	—	—	8					
	100	3R	5BCLS-3R	1	50	3	—	—	8					
	130	4R	5BCLS-4R	1	50	3	—	—	8					
	150	5R	5BCLS-5R	1	50	3	—	—	8					
	170	6R	5BCLS-6R	1	50	3	—	—	8					
	200	9R	5BCLS-9R	1	50	3	—	—	8					
	230	12R	5BCLS-12R	1	50	3	—	—	8					
	390	18R	5BCLS-18R	2	50	3	—	—	17					
	450	24R	5BCLS-24R	2	50	3	—	—	17					
4.3	480	26R	4BCLS-26R	2	50	3	—	—	17					
5.08	30	—	5HCLS-30	1	50	3	—	15.9	8	—	—	TC66690602	TC66690702	TC66700203
	70	2R	5HCLS-2R	1	50	3	—	15.9	8					
	100	3R	5HCLS-3R	1	50	3	—	15.9	8					
	130	4R	5HCLS-4R	1	50	3	—	15.9	8					
	150	5R	5HCLS-5R	1	50	3	—	15.9	8					
	170	6R	5HCLS-6R	1	50	3	—	15.9	8					
	200	9R	5HCLS-9R	1	50	3	—	15.9	8					
	230	12R	5HCLS-12R	1	50	3	—	15.9	8					
	390	18R	5HCLS-18R	2	50	3	—	15.9	17					
	450	24R	5HCLS-24R	2	50	3	—	15.9	17					

Notes

- ① Includes end fittings.
- ② Disconnect only.

3.6

Current Limiting Fuses

ACLS, BCLS, CLS, HCLS and NCLS Type Fuses

CLS Type Current Limiting Fuses, continued

Max. Design Voltage (kV)	Current Rating (A)	"R" Designation	Catalog Number	Barrel Number	Interrupting Rating rms (kA Sym.)	Diameter (Inches)	Clip Center (Inches)	Length (Inches)	Approx. Shipping Weight (Lbs)	Catalog Number		Performance Curves		
										Live Parts ^①	End Fittings ^②	Minimum Melting Time	Total Clearing Time	Peak Let-Through Current
5.08	70	2R	5CLS70-2R	2	50	3	—	—	20	—	—	TC66690602	TC66690702	TC66700203
	100	3R	5CLS70-3R	2	50	3	—	—	20	—	—	—	—	—
	130	4R	5CLS70-4R	2	50	3	—	—	20	—	—	—	—	—
	150	5R	5CLS70-5R	2	50	3	—	—	20	—	—	—	—	—
	170	6R	5CLS70-6R	2	50	3	—	—	20	—	—	—	—	—
	200	9R	5CLS70-9R	2	50	3	—	—	20	—	—	—	—	—
	230	12R	5CLS70-12R	2	50	4	—	—	40	—	—	—	—	—
	390	18R	5CLS70-18R	2	50	4	—	—	40	—	—	—	—	—
	450	24R	5CLS70-24R	2	50	4	—	—	40	—	—	—	—	—
	600	32R	5CLS70-32R	2	50	4	—	—	40	—	—	—	—	—
	650	36R	5CLS70-36R	2	50	4	—	—	40	—	—	—	—	—
	700	44R	5CLS70-44R	2	50	4	—	—	40	—	—	—	—	—
	5.5	70	2R	5LCLS-2R	1	50	3	14	17.9	11	CLE-NL-D	—	TC51285302	TC51285402
100		3R	5LCLS-3R	1	50	3	14	17.9	11	CLE-DL-D	CLE-DF-D	—	—	—
130		4R	5LCLS-4R	1	50	3	14	17.9	11	CLE-DF-D	CLE-DF-D	—	—	—
150		5R	5LCLS-5R	1	50	3	14	17.9	11	—	—	—	—	—
170		6R	5LCLS-6R	1	50	3	14	17.9	11	—	—	—	—	—
200		9R	5LCLS-9R	1	50	3	14	17.9	11	—	—	—	—	—
230		12R	5LCLS-12R	1	50	3	14	17.9	11	—	—	—	—	—
390		18R	5LCLS-18R	2	50	3	14	17.9	22	—	—	—	—	—
450		24R	5LCLS-24R	2	50	3	14	17.9	22	—	—	—	—	—
8.3	70	2R	8CLS-2R	1	50	3	12	15.9	7	CLE-NL-D	—	TC66700602	TC66700702	TC66700205
	100	3R	8CLS-3R	1	50	3	12	15.9	7	CLE-DL-D	CLE-DF-D	—	—	—
	130	4R	8CLS-4R	1	50	3	12	15.9	7	—	—	—	—	—
	150	5R	8CLS-5R	1	50	3	12	15.9	7	—	—	—	—	—
	170	6R	8CLS-6R	1	50	3	12	15.9	7	—	—	—	—	—
	200	9R	7CLS-9R	1	50	3	12	15.9	7	—	—	—	—	—
	230	12R	7CLS-12R	1	50	3	12	15.9	7	—	—	—	—	—
7.2	390	18R	7CLS-18R	2	50	3	12	15.9	16	CLE-NL-E	—	TC66700602	TC66700702	TC66700205
	450	24R	7CLS-24R	2	50	3	12	15.9	16	CLE-DL-E	CLE-DF-E	—	—	—
8.3	70	2R	7BCLS-2R	1	50	3	—	—	—	—	—	TC66700602	TC66700702	TC66740205
	100	3R	7BCLS-3R	1	50	3	—	—	—	—	—	—	—	—
	130	4R	7BCLS-4R	1	50	3	—	—	—	—	—	—	—	—
	150	5R	7BCLS-5R	1	50	3	—	—	—	—	—	—	—	—
	170	6R	7BCLS-6R	1	50	3	—	—	—	—	—	—	—	—
	200	9R	7BCLS-9R	1	50	3	—	—	—	—	—	—	—	—
	230	12R	7BCLS-12R	1	50	3	—	—	—	—	—	—	—	—
7.2	390	18R	7BCLS-18R	2	50	3	—	—	—	—	—	—	—	—
	450	24R	7BCLS-24R	2	50	3	—	—	—	—	—	—	—	—

Notes

① Includes end fittings.

② Disconnect only.

CLS Type Current Limiting Fuses, continued

Max. Design Voltage (kV)	Current Rating (A)	"R" Designation	Catalog Number	Barrel Number	Interrupting Rating rms (kA Sym.)	Diameter (Inches)	Clip Center (Inches)	Length (Inches)	Approx. Shipping Weight (Lbs)	Catalog Number		Performance Curves		
										Live Parts ①	End Fittings ②	Minimum Melting Time	Total Clearing Time	Peak Let-Through Current
8.3	70	2R	8ACLS-2R	1	50	3	—	15.9	8	—	—	TC66700602	TC66700702	TC66740205
	100	3R	8ACLS-3R	1	50	3	—	15.9	8	—	—	—	—	—
	130	4R	8ACLS-4R	1	50	3	—	15.9	8	—	—	—	—	—
	150	5R	8ACLS-5R	1	50	3	—	15.9	8	—	—	—	—	—
	170	6R	8ACLS-6R	1	50	3	—	15.9	8	—	—	—	—	—
7.2	200	9R	7ACLS-9R	1	50	3	—	15.9	8	—	—	—	—	—
	230	12R	7ACLS-12R	1	50	3	—	15.9	8	—	—	—	—	—
	390	18R	7ACLS-18R	2	50	3	—	15.9	17	—	—	—	—	—
	450	24R	7ACLS-24R	2	50	3	—	15.9	17	—	—	—	—	—
	450	24R	7CLS70-24R	2	50	3	—	—	20	—	—	—	—	—
	650	36R	7CLS70-36R	3	50	3	—	—	30	—	—	—	—	—
	700	44R	7CLS70-44R	2	50	4	—	—	40	—	—	—	—	—
8.3	15	—	8CLS-15	1	50	3	14	17.9	11	CLE-NL-D	—	TC66664202	TC66664302	TC66679802
	30	—	8CLS-30	1	50	3	14	17.9	11	CLE-DL-D	CLS-DF-D	—	—	—
	60	—	8CLS-60	1	50	3	14	17.9	11	—	—	—	—	—
	70	—	8CLS-70	1	50	3	14	17.9	11	—	—	—	—	—
	90	—	8CLS-90	1	50	3	14	17.9	11	—	—	—	—	—
	110	—	8CLS-110	1	50	3	14	17.9	11	—	—	—	—	—
	125	—	8CLS-125	1	50	3	14	17.9	11	—	—	—	—	—
	150	—	8CLS-150	2	50	3	14	17.9	22	CLE-NL-E	—	TC66664202	TC66664302	TC66679802
	200	—	8CLS-200	2	50	3	14	17.9	22	CLE-DL-E	CLE-DF-E	—	—	—
	225	—	8CLS-225	2	50	3	14	17.9	22	—	—	—	—	—

Notes

- ① Includes end fittings.
- ② Disconnect only.

3.6

Current Limiting Fuses

ACLS, BCLS, CLS, HCLS and NCLS Type Fuses

CLS Type Current Limiting Fuses—Mounting

Maximum Design Voltage (kV)	Current Rating (Amperes)	"R" Designation	Catalog Number	Mounting (Includes Live Parts, End Fittings)			
				Type	Voltage (BIL) kV	Catalog Number Porcelain	Catalog Number Glass-Polyester
2.54	25	—	2CLS-25	Non-disconnect	60	2CLE-PNM-D	2CLE-GNM-D
	70	2R	2CLS-2R	Disconnect	60	2CLE-PDM-D	2CLE-GDM-E
	100	3R	2CLS-3R				
	130	4R	2CLS-4R				
	150	5R	2CLS-5R				
	170	6R	2CLS-6R				
	200	9R	2CLS-9R				
	230	12R	2CLS-12R				
	390	18R	2CLS-18R	Non-disconnect	60	2CLE-PNM-E	2CLE-GNM-E
	450	24R	2CLS-24R	Disconnect	60	2CLE-PDME	2CLE-GDM-E
	25	—	2ACLS-25	For use with Amgard 400A motor starters			
	70	2R	2ACLS-2R				
	100	3R	2ACLS-3R				
	130	4R	2ACLS-4R				
	150	5R	2ACLS-5R				
	170	6R	2ACLS-6R				
	200	9R	2ACLS-9R				
	230	12R	2ACLS-12R				
	390	18R	2ACLS-18R				
	450	24R	2ACLS-24R				
25	—	2BCLS-25	Bolt-in				
70	2R	2BCLS-2R					
100	3R	2BCLS-3R					
130	4R	2BCLS-4R					
150	5R	2BCLS-5R					
170	6R	2BCLS-6R					
200	9R	2BCLS-9R					
230	12R	2BCLS-12R					
390	18R	2BCLS-18R					
450	24R	2BCLS-24R					
25	—	2HCLS-25	Hermetically sealed fuses for use with Amgard 400A motor starters				
70	2R	2HCLS-2R					
100	3R	2HCLS-3R					
130	4R	2HCLS-4R					
150	5R	2HCLS-5R					
170	6R	2HCLS-6R					
200	9R	2HCLS-9R					
230	12R	2HCLS-12R					
390	18R	2HCLS-18R					
450	24R	2HCLS-24R					
5.5	30	—	5CLS-30	Non-disconnect	60	5HLE-PNM-D	5HLE-GNM-D
	70	2R	5CLS-2R	Disconnect	60	5HLE-PDM-D	5HLE-GDM-E
	100	3R	5CLS-3R				
	130	4R	5CLS-4R				
	150	5R	5CLS-5R				
	170	6R	5CLS-6R				
	200	9R	5CLS-9R				
	230	12R	5CLS-12R				

CLS Type Current Limiting Fuses—Mounting, continued

Maximum Design Voltage (kV)	Current Rating (Amperes)	"R" Designation	Catalog Number	Mounting (Includes Live Parts, End Fittings)			
				Type	Voltage (BIL) kV	Catalog Number Porcelain	Catalog Number Glass-Polyester
5.5	390	18R	5CLS-18R	Non-disconnect	60	5HLE-PNM-E	5HLE-GNM-E
	450	24R	5CLS-24R	Disconnect	60	5HLE-PDME	5HLE-GDM-E
5.08	30	—	5ACLS-30	For use with Ampgard 400A motor starters			
	70	2R	5ACLS-2R				
	100	3R	5ACLS-3R				
	130	4R	5ACLS-4R				
	150	5R	5ACLS-5R				
	170	6R	5ACLS-6R				
	200	9R	5ACLS-9R				
	230	12R	5ACLS-12R				
	390	18R	5ACLS-18R				
	450	24R	5ACLS-24R				
4.3	480	26R	4ACLS-26R				
5.08	30	—	5BCLS-30	Bolt-in			
	70	2R	5BCLS-2R				
	100	3R	5BCLS-3R				
	130	4R	5BCLS-4R				
	150	5R	5BCLS-5R				
	170	6R	5BCLS-6R				
	200	9R	5BCLS-9R				
	230	12R	5BCLS-12R				
	390	18R	5BCLS-18R				
	450	24R	5BCLS-24R				
4.3	480	26R	4BCLS-26R				
5.08	30	—	5HCLS-30	Hermetically sealed for use with Ampgard 400A motor starters			
	70	2R	5HCLS-2R				
	100	3R	5HCLS-3R				
	130	4R	5HCLS-4R				
	150	5R	5HCLS-5R				
	170	6R	5HCLS-6R				
	200	9R	5HCLS-9R				
	230	12R	5HCLS-12R				
	390	18R	5HCLS-18R				
	450	24R	5HCLS-24R				
	70	2R	5CLS70-2R	For use with Ampgard 800A motor starters			
	100	3R	5CLS70-3R				
	130	4R	5CLS70-4R				
	150	5R	5CLS70-5R				
	170	6R	5CLS70-6R				
	200	9R	5CLS70-9R				
	230	12R	5CLS70-12R				
390	18R	5CLS70-18R					
450	24R	5CLS70-24R					
600	32R	5CLS70-32R					
650	36R	5CLS70-36R					
700	44R	5CLS70-44R					

3.6

Current Limiting Fuses

ACLS, BCLS, CLS, HCLS and NCLS Type Fuses

CLS Type Current Limiting Fuses—Mounting, continued

Maximum Design Voltage (kV)	Current Rating (Amperes)	"R" Designation	Catalog Number	Mounting (Includes Live Parts, End Fittings)			
				Type	Voltage (BIL) kV	Catalog Number Porcelain	Catalog Number Glass-Polyester
5.5	70	2R	5LCLS-2R	Non-disconnect	60	5CLE-PNM-D	5CLE-GNM-D
	100	3R	5LCLS-3R	Disconnect	60	5CLE-PDM-D	5CLE-GDM-D
	130	4R	5LCLS-4R	Disconnect	75	8CLE-PDM-D	8CLE-GDM-D
	150	5R	5LCLS-5R				
	170	6R	5LCLS-6R				
	200	9R	5LCLS-9R				
	230	12R	5LCLS-12R				
	390	18R	5LCLS-18R				
	450	24R	5LCLS-24R				
8.3	70	2R	8CLS-2R	Non-disconnect	75	8HLE-PNM-D	8HLE-GNM-D
	100	3R	8CLS-3R	Disconnect	75	8HLE-PDM-D	8HLE-GDM-D
	130	4R	8CLS-4R				
	150	5R	8CLS-5R				
	170	6R	8CLS-6R				
	200	9R	7CLS-9R				
	230	12R	7CLS-12R				
7.2	390	18R	7CLS-18R	Non-disconnect	75	8HLE-PDM-E	8HLE-GNM-E
	450	24R	7CLS-24R	Disconnect	75	8HLE-PDM-E	8HLE-GDM-E
8.3	70	2R	7BCLS-2R	Bolt-in			
	100	3R	7BCLS-3R				
	130	4R	7BCLS-4R				
	150	5R	7BCLS-5R				
	170	6R	7BCLS-6R				
	200	9R	7BCLS-9R				
	230	12R	7BCLS-12R				
7.2	390	18R	7BCLS-18R				
	450	24R	7BCLS-24R				
8.3	70	2R	8ACLS-2R	For use with Amppgard 400A motor starters			
	100	3R	8ACLS-3R				
	130	4R	8ACLS-4R				
	150	5R	8ACLS-5R				
	170	6R	8ACLS-6R				
7.2	200	9R	7ACLS-9R				
	230	12R	7ACLS-12R				
	390	18R	7ACLS-18R				
	450	24R	7ACLS-24R				
	450	24R	7CLS70-24R	For use with Amppgard 800A motor starters			
	650	36R	7CLS70-36R				
	700	44R	7CLS70-44R				
8.3	15	—	8CLS-15	Non-disconnect	75	8CLE-PNM-D	8CLE-GNM-D
	30	—	8CLS-30	Disconnect	75	8CLE-PDM-D	8CLE-GDM-D
	60	—	8CLS-60				
	70	—	8CLS-70				
	90	—	8CLS-90				
	110	—	8CLS-110				
	125	—	8CLS-125				
	150	—	8CLS-150	Non-disconnect	75	8CLE-PNM-E	8CLE-GNM-E
	200	—	8CLS-200	Disconnect	75	8CLE-PDM-E	8CLE-GDM-E
	225	—	8CLS-225				

Product Selection

CLS Type

CLS Type Current Limiting Fuses

Maximum Design Voltage (kV)	Current Rating (Amperes)	"R" Designation	Barrel Number	Interrupting Rating rms (kA Sym.)	Diameter		Clip Center	Length	Approximate Shipping Weight Lbs (kg)	Performance Curves		Peak Let-Through Current	Catalog Number
					Approximate	Dimensions in Inches (mm)	Not applicable			Minimum Melting Time	Total Clearing Time		
2.54	25	—	1	50	3.00 (76.2)	7.00 (177.8)	10.80 (274.3)	7 (3.18)	TC66664702	TC66664704	TC66700202	2CLS-25	
	70	2R	1	50	3.00 (76.2)	7.00 (177.8)	10.80 (274.3)	7 (3.18)	TC66664702	TC66664704	TC66700202	2CLS-2R	
	100	3R	1	50	3.00 (76.2)	7.00 (177.8)	10.80 (274.3)	7 (3.18)	TC66664702	TC66664704	TC66700202	2CLS-3R	
	130	4R	1	50	3.00 (76.2)	7.00 (177.8)	10.80 (274.3)	7 (3.18)	TC66664702	TC66664704	TC66700202	2CLS-4R	
	150	5R	1	50	3.00 (76.2)	7.00 (177.8)	10.80 (274.3)	7 (3.18)	TC66664702	TC66664704	TC66700202	2CLS-5R	
	170	6R	1	50	3.00 (76.2)	7.00 (177.8)	10.80 (274.3)	7 (3.18)	TC66664702	TC66664704	TC66700202	2CLS-6R	
	200	9R	1	50	3.00 (76.2)	7.00 (177.8)	10.80 (274.3)	7 (3.18)	TC66664702	TC66664704	TC66700202	2CLS-9R	
	230	12R	1	50	3.00 (76.2)	7.00 (177.8)	10.80 (274.3)	7 (3.18)	TC66664702	TC66664704	TC66700202	2CLS-12R	
	390	18R	2	50	3.00 (76.2)	7.00 (177.8)	10.80 (274.3)	16 (7.26)	TC66664702	TC66664704	TC66700202	2CLS-18R	
	450	24R	2	50	3.00 (76.2)	7.00 (177.8)	10.80 (274.3)	16 (7.26)	TC66664702	TC66664704	TC66700202	2CLS-24R	
	25	—	1	50	3.00 (76.2)	Not applicable	10.80 (274.3)	7 (3.18)	TC66664702	TC66664704	TC66700202	2ACLS-25	
	70	2R	1	50	3.00 (76.2)	Not applicable	10.80 (274.3)	7 (3.18)	TC66664702	TC66664704	TC66700202	2ACLS-2R	
	100	3R	1	50	3.00 (76.2)	Not applicable	10.80 (274.3)	7 (3.18)	TC66664702	TC66664704	TC66700202	2ACLS-3R	
	130	4R	1	50	3.00 (76.2)	Not applicable	10.80 (274.3)	7 (3.18)	TC66664702	TC66664704	TC66700202	2ACLS-4R	
	150	5R	1	50	3.00 (76.2)	Not applicable	10.80 (274.3)	7 (3.18)	TC66664702	TC66664704	TC66700202	2ACLS-5R	
	170	6R	1	50	3.00 (76.2)	Not applicable	10.80 (274.3)	7 (3.18)	TC66664702	TC66664704	TC66700202	2ACLS-6R	
	200	9R	1	50	3.00 (76.2)	Not applicable	10.80 (274.3)	7 (3.18)	TC66664702	TC66664704	TC66700202	2ACLS-9R	
	230	12R	1	50	3.00 (76.2)	Not applicable	10.80 (274.3)	7 (3.18)	TC66664702	TC66664704	TC66700202	2ACLS-12R	
	390	18R	2	50	3.00 (76.2)	Not applicable	10.80 (274.3)	16 (7.26)	TC66664702	TC66664704	TC66700202	2ACLS-18R	
	450	24R	2	50	3.00 (76.2)	Not applicable	10.80 (274.3)	16 (7.26)	TC66664702	TC66664704	TC66700202	2ACLS-24R	
	25	—	1	50	3.00 (76.2)	Not applicable	10.80 (274.3)	8 (3.63)	TC66664702	TC66664704	TC66700202	2BCLS-25	
	70	2R	1	50	3.00 (76.2)	Not applicable	10.80 (274.3)	8 (3.63)	TC66664702	TC66664704	TC66700202	2BCLS-2R	
	100	3R	1	50	3.00 (76.2)	Not applicable	10.80 (274.3)	8 (3.63)	TC66664702	TC66664704	TC66700202	2BCLS-3R	
	130	4R	1	50	3.00 (76.2)	Not applicable	10.80 (274.3)	8 (3.63)	TC66664702	TC66664704	TC66700202	2BCLS-4R	
	150	5R	1	50	3.00 (76.2)	Not applicable	10.80 (274.3)	8 (3.63)	TC66664702	TC66664704	TC66700202	2BCLS-5R	
	170	6R	1	50	3.00 (76.2)	Not applicable	10.80 (274.3)	8 (3.63)	TC66664702	TC66664704	TC66700202	2BCLS-6R	
	200	9R	1	50	3.00 (76.2)	Not applicable	10.80 (274.3)	8 (3.63)	TC66664702	TC66664704	TC66700202	2BCLS-9R	
	230	12R	1	50	3.00 (76.2)	Not applicable	10.80 (274.3)	8 (3.63)	TC66664702	TC66664704	TC66700202	2BCLS-12R	
	390	18R	2	50	3.00 (76.2)	Not applicable	10.80 (274.3)	17 (7.72)	TC66664702	TC66664704	TC66700202	2BCLS-18R	
	450	24R	2	50	3.00 (76.2)	Not applicable	10.80 (274.3)	17 (7.72)	TC66664702	TC66664704	TC66700202	2BCLS-24R	
	25	—	1	50	3.00 (76.2)	Not applicable	10.80 (274.3)	7 (3.18)	TC66664702	TC66664704	TC66700202	2HCLS-25	
	70	2R	1	50	3.00 (76.2)	Not applicable	10.80 (274.3)	7 (3.18)	TC66664702	TC66664704	TC66700202	2HCLS-2R	
	100	3R	1	50	3.00 (76.2)	Not applicable	10.80 (274.3)	7 (3.18)	TC66664702	TC66664704	TC66700202	2HCLS-3R	
	130	4R	1	50	3.00 (76.2)	Not applicable	10.80 (274.3)	7 (3.18)	TC66664702	TC66664704	TC66700202	2HCLS-4R	
	150	5R	1	50	3.00 (76.2)	Not applicable	10.80 (274.3)	7 (3.18)	TC66664702	TC66664704	TC66700202	2HCLS-5R	
	170	6R	1	50	3.00 (76.2)	Not applicable	10.80 (274.3)	7 (3.18)	TC66664702	TC66664704	TC66700202	2HCLS-6R	
	200	9R	1	50	3.00 (76.2)	Not applicable	10.80 (274.3)	7 (3.18)	TC66664702	TC66664704	TC66700202	2HCLS-9R	
	230	12R	1	50	3.00 (76.2)	Not applicable	10.80 (274.3)	7 (3.18)	TC66664702	TC66664704	TC66700202	2HCLS-12R	
	390	18R	2	50	3.00 (76.2)	Not applicable	10.80 (274.3)	16 (7.26)	TC66664702	TC66664704	TC66700202	2HCLS-18R	
	450	24R	2	50	3.00 (76.2)	Not applicable	10.80 (274.3)	16 (7.26)	TC66664702	TC66664704	TC66700202	2HCLS-24R	

3.6

Current Limiting Fuses

ACLS, BCLS, CLS, HCLS and NCLS Type Fuses

CLS Type Current Limiting Fuses, continued

Maximum Design Voltage (kV)	Current Rating (Amperes)	"R" Designation	Barrel Number	Interrupting Rating rms (kA Sym.)	Clip Center		Length	Approximate Shipping Weight Lbs (kg)	Performance Curves		Peak Let-Through Current	Catalog Number
					Diameter	Approximate Dimensions in Inches (mm)			Minimum Melting Time	Total Clearing Time		
5.08	30	—	1	50	3.00 (76.2)	12.00 (304.8)	15.90 (403.9)	8 (3.63)	TC66690602	TC66690702	TC66700203	5CLS-30
	70	2R	1	50	3.00 (76.2)	12.00 (304.8)	15.90 (403.9)	8 (3.63)	TC66690602	TC66690702	TC66700203	5CLS-2R
	100	3R	1	50	3.00 (76.2)	12.00 (304.8)	15.90 (403.9)	8 (3.63)	TC66690602	TC66690702	TC66700203	5CLS-3R
	130	4R	1	50	3.00 (76.2)	12.00 (304.8)	15.90 (403.9)	8 (3.63)	TC66690602	TC66690702	TC66700203	5CLS-4R
	150	5R	1	50	3.00 (76.2)	12.00 (304.8)	15.90 (403.9)	8 (3.63)	TC66690602	TC66690702	TC66700203	5CLS-5R
	170	6R	1	50	3.00 (76.2)	12.00 (304.8)	15.90 (403.9)	8 (3.63)	TC66690602	TC66690702	TC66700203	5CLS-6R
	200	9R	1	50	3.00 (76.2)	12.00 (304.8)	15.90 (403.9)	8 (3.63)	TC66690602	TC66690702	TC66700203	5CLS-9R
	230	12R	1	50	3.00 (76.2)	12.00 (304.8)	15.90 (403.9)	8 (3.63)	TC66690602	TC66690702	TC66700203	5CLS-12R
	390	18R	2	50	3.00 (76.2)	12.00 (304.8)	15.90 (403.9)	17 (7.72)	TC66690602	TC66690702	TC66700203	5CLS-18R
	450	24R	2	50	3.00 (76.2)	12.00 (304.8)	15.90 (403.9)	17 (7.72)	TC66690602	TC66690702	TC66700203	5CLS-24R
5.08	30	—	1	50	3.00 (76.2)	Not applicable	15.90 (403.9)	8 (3.63)	TC66690602	TC66690702	TC66700203	5ACLS-30
	70	2R	1	50	3.00 (76.2)	Not applicable	15.90 (403.9)	8 (3.63)	TC66690602	TC66690702	TC66700203	5ACLS-2R
	100	3R	1	50	3.00 (76.2)	Not applicable	15.90 (403.9)	8 (3.63)	TC66690602	TC66690702	TC66700203	5ACLS-3R
	130	4R	1	50	3.00 (76.2)	Not applicable	15.90 (403.9)	8 (3.63)	TC66690602	TC66690702	TC66700203	5ACLS-4R
	150	5R	1	50	3.00 (76.2)	Not applicable	15.90 (403.9)	8 (3.63)	TC66690602	TC66690702	TC66700203	5ACLS-5R
	170	6R	1	50	3.00 (76.2)	Not applicable	15.90 (403.9)	8 (3.63)	TC66690602	TC66690702	TC66700203	5ACLS-6R
	200	9R	1	50	3.00 (76.2)	Not applicable	15.90 (403.9)	8 (3.63)	TC66690602	TC66690702	TC66700203	5ACLS-9R
	230	12R	1	50	3.00 (76.2)	Not applicable	15.90 (403.9)	8 (3.63)	TC66690602	TC66690702	TC66700203	5ACLS-12R
	390	18R	2	50	3.00 (76.2)	Not applicable	15.90 (403.9)	17 (7.72)	TC66690602	TC66690702	TC66700203	5ACLS-18R
	450	24R	2	50	3.00 (76.2)	Not applicable	15.90 (403.9)	17 (7.72)	TC66690602	TC66690702	TC66700203	5ACLS-24R
4.3	480	26R	2	50	3.00 (76.2)	Not applicable	15.90 (403.9)	17 (7.72)	TC66690602	TC66690702	TC66700203	4ACLS-26R
5.08	30	—	1	50	3.00 (76.2)	Not applicable	15.90 (403.9)	8 (3.63)	TC66690602	TC66690702	TC66700203	5BCLS-30
	70	2R	1	50	3.00 (76.2)	Not applicable	15.90 (403.9)	8 (3.63)	TC66690602	TC66690702	TC66700203	5BCLS-2R
	100	3R	1	50	3.00 (76.2)	Not applicable	15.90 (403.9)	8 (3.63)	TC66690602	TC66690702	TC66700203	5BCLS-3R
	130	4R	1	50	3.00 (76.2)	Not applicable	15.90 (403.9)	8 (3.63)	TC66690602	TC66690702	TC66700203	5BCLS-4R
	150	5R	1	50	3.00 (76.2)	Not applicable	15.90 (403.9)	8 (3.63)	TC66690602	TC66690702	TC66700203	5BCLS-5R
	170	6R	1	50	3.00 (76.2)	Not applicable	15.90 (403.9)	8 (3.63)	TC66690602	TC66690702	TC66700203	5BCLS-6R
	200	9R	1	50	3.00 (76.2)	Not applicable	15.90 (403.9)	8 (3.63)	TC66690602	TC66690702	TC66700203	5BCLS-9R
	230	12R	1	50	3.00 (76.2)	Not applicable	15.90 (403.9)	8 (3.63)	TC66690602	TC66690702	TC66700203	5BCLS-12R
	390	18R	2	50	3.00 (76.2)	Not applicable	15.90 (403.9)	17 (7.72)	TC66690602	TC66690702	TC66700203	5BCLS-18R
	450	24R	2	50	3.00 (76.2)	Not applicable	15.90 (403.9)	17 (7.72)	TC66690602	TC66690702	TC66700203	5BCLS-24R
4.3	480	26R	2	50	3.00 (76.2)	Not applicable	15.90 (403.9)	17 (7.72)	TC66690602	TC66690702	TC66700203	4BCLS-26R
5.08	30	—	1	50	3.00 (76.2)	Not applicable	15.90 (403.9)	8 (3.63)	TC66690602	TC66690702	TC66700203	5HCLS-30
	70	2R	1	50	3.00 (76.2)	Not applicable	15.90 (403.9)	8 (3.63)	TC66690602	TC66690702	TC66700203	5HCLS-2R
	100	3R	1	50	3.00 (76.2)	Not applicable	15.90 (403.9)	8 (3.63)	TC66690602	TC66690702	TC66700203	5HCLS-3R
	130	4R	1	50	3.00 (76.2)	Not applicable	15.90 (403.9)	8 (3.63)	TC66690602	TC66690702	TC66700203	5HCLS-4R
	150	5R	1	50	3.00 (76.2)	Not applicable	15.90 (403.9)	8 (3.63)	TC66690602	TC66690702	TC66700203	5HCLS-5R
	170	6R	1	50	3.00 (76.2)	Not applicable	15.90 (403.9)	8 (3.63)	TC66690602	TC66690702	TC66700203	5HCLS-6R
	200	9R	1	50	3.00 (76.2)	Not applicable	15.90 (403.9)	8 (3.63)	TC66690602	TC66690702	TC66700203	5HCLS-9R
	230	12R	1	50	3.00 (76.2)	Not applicable	15.90 (403.9)	8 (3.63)	TC66690602	TC66690702	TC66700203	5HCLS-12R
	390	18R	2	50	3.00 (76.2)	Not applicable	15.90 (403.9)	17 (7.72)	TC66690602	TC66690702	TC66700203	5HCLS-18R
	450	24R	2	50	3.00 (76.2)	Not applicable	15.90 (403.9)	17 (7.72)	TC66690602	TC66690702	TC66700203	5HCLS-24R

CLS Type Current Limiting Fuses, continued

Maximum Design Voltage (kV)	Current Rating (Amperes)	"R" Designation	Barrel Number	Interrupting Rating rms (kA Sym.)	Diameter	Clip Center	Length	Approximate Shipping Weight Lbs (kg)	Performance Curves		Peak Let-Through Current	Catalog Number
									Minimum Melting Time	Total Clearing Time		
					Approximate Dimensions in Inches (mm)							
5.08	70	2R	2	50	3.00 (76.2)	Not applicable	15.90 (403.9)	20 (9.08)	TC66690602	TC66690702	TC66700203	5CLS70-2R
	100	3R	2	50	3.00 (76.2)	Not applicable	15.90 (403.9)	20 (9.08)	TC66690602	TC66690702	TC66700203	5CLS70-3R
	130	4R	2	50	3.00 (76.2)	Not applicable	15.90 (403.9)	20 (9.08)	TC66690602	TC66690702	TC66700203	5CLS70-4R
	150	5R	2	50	3.00 (76.2)	Not applicable	15.90 (403.9)	20 (9.08)	TC66690602	TC66690702	TC66700203	5CLS70-5R
	170	6R	2	50	3.00 (76.2)	Not applicable	15.90 (403.9)	20 (9.08)	TC66690602	TC66690702	TC66700203	5CLS70-6R
	200	9R	2	50	3.00 (76.2)	Not applicable	15.90 (403.9)	20 (9.08)	TC66690602	TC66690702	TC66700203	5CLS70-9R
	230	12R	2	50	4.00 (101.6)	Not applicable	15.90 (403.9)	40 (18.16)	TC66690602	TC66690702	TC66700203	5CLS70-12R
	390	18R	2	50	4.00 (101.6)	Not applicable	15.90 (403.9)	40 (18.16)	TC66690602	TC66690702	TC66700203	5CLS70-18R
	450	24R	2	50	4.00 (101.6)	Not applicable	15.90 (403.9)	40 (18.16)	TC66690602	TC66690702	TC66700203	5CLS70-24R
	600	32R	2	50	4.00 (101.6)	Not applicable	15.90 (403.9)	40 (18.16)	TC66690602	TC66690702	TC66700203	5CLS70-32R
	650	36R	2	50	4.00 (101.6)	Not applicable	15.90 (403.9)	40 (18.16)	TC66690602	TC66690702	TC66700203	5CLS70-36R
	700	44R	2	50	4.00 (101.6)	Not applicable	15.90 (403.9)	40 (18.16)	TC66690602	TC66690702	TC66700203	5CLS70-44R
5.5	70	2R	1	50	3.00 (76.2)	14.00 (355.6)	17.90 (454.7)	11 (4.99)	TC51285302	TC51285402	TC66700204	5LCLS-2R
	100	3R	1	50	3.00 (76.2)	14.00 (355.6)	17.90 (454.7)	11 (4.99)	TC51285302	TC51285402	TC66700204	5LCLS-3R
	130	4R	1	50	3.00 (76.2)	14.00 (355.6)	17.90 (454.7)	11 (4.99)	TC51285302	TC51285402	TC66700204	5LCLS-4R
	150	5R	1	50	3.00 (76.2)	14.00 (355.6)	17.90 (454.7)	11 (4.99)	TC51285302	TC51285402	TC66700204	5LCLS-5R
	170	6R	1	50	3.00 (76.2)	14.00 (355.6)	17.90 (454.7)	11 (4.99)	TC51285302	TC51285402	TC66700204	5LCLS-6R
	200	9R	1	50	3.00 (76.2)	14.00 (355.6)	17.90 (454.7)	11 (4.99)	TC51285302	TC51285402	TC66700204	5LCLS-9R
	230	12R	1	50	3.00 (76.2)	14.00 (355.6)	17.90 (454.7)	11 (4.99)	TC51285302	TC51285402	TC66700204	5LCLS-12R
	390	18R	2	50	3.00 (76.2)	14.00 (355.6)	17.90 (454.7)	22 (9.99)	TC51285302	TC51285402	TC66700204	5LCLS-18R
	450	24R	2	50	3.00 (76.2)	14.00 (355.6)	17.90 (454.7)	22 (9.99)	TC51285302	TC51285402	TC66700204	5LCLS-24R
	8.3	70	2R	1	50	3.00 (76.2)	12.00 (304.8)	15.90 (403.9)	7 (3.18)	TC66700602	TC66700702	TC66700205
100		3R	1	50	3.00 (76.2)	12.00 (304.8)	15.90 (403.9)	7 (3.18)	TC66700602	TC66700702	TC66700205	8CLS-3R
130		4R	1	50	3.00 (76.2)	12.00 (304.8)	15.90 (403.9)	7 (3.18)	TC66700602	TC66700702	TC66700205	8CLS-4R
150		5R	1	50	3.00 (76.2)	12.00 (304.8)	15.90 (403.9)	7 (3.18)	TC66700602	TC66700702	TC66700205	8CLS-5R
170		6R	1	50	3.00 (76.2)	12.00 (304.8)	15.90 (403.9)	7 (3.18)	TC66700602	TC66700702	TC66700205	8CLS-6R
7.2	200	9R	1	50	3.00 (76.2)	12.00 (304.8)	15.90 (403.9)	7 (3.18)	TC66700602	TC66700702	TC66700205	7CLS-9R
	230	12R	1	50	3.00 (76.2)	12.00 (304.8)	15.90 (403.9)	7 (3.18)	TC66700602	TC66700702	TC66700205	7CLS-12R
	390	18R	2	50	3.00 (76.2)	12.00 (304.8)	15.90 (403.9)	16 (7.26)	TC66700602	TC66700702	TC66700205	7CLS-18R
	450	24R	2	50	3.00 (76.2)	12.00 (304.8)	15.90 (403.9)	16 (7.26)	TC66700602	TC66700702	TC66700205	7CLS-24R
8.3	70	2R	1	50	3.00 (76.2)	Not applicable	15.90 (403.9)	7 (3.18)	TC66700602	TC66700702	TC66740205	7BCLS-2R
	100	3R	1	50	3.00 (76.2)	Not applicable	15.90 (403.9)	7 (3.18)	TC66700602	TC66700702	TC66740205	7BCLS-3R
	130	4R	1	50	3.00 (76.2)	Not applicable	15.90 (403.9)	7 (3.18)	TC66700602	TC66700702	TC66740205	7BCLS-4R
	150	5R	1	50	3.00 (76.2)	Not applicable	15.90 (403.9)	7 (3.18)	TC66700602	TC66700702	TC66740205	7BCLS-5R
	170	6R	1	50	3.00 (76.2)	Not applicable	15.90 (403.9)	7 (3.18)	TC66700602	TC66700702	TC66740205	7BCLS-6R
7.2	200	9R	1	50	3.00 (76.2)	Not applicable	15.90 (403.9)	7 (3.18)	TC66700602	TC66700702	TC66740205	7BCLS-9R
	230	12R	1	50	3.00 (76.2)	Not applicable	15.90 (403.9)	7 (3.18)	TC66700602	TC66700702	TC66740205	7BCLS-12R
	390	18R	2	50	3.00 (76.2)	Not applicable	15.90 (403.9)	16 (7.26)	TC66700602	TC66700702	TC66740205	7BCLS-18R
	450	24R	2	50	3.00 (76.2)	Not applicable	15.90 (403.9)	16 (7.26)	TC66700602	TC66700702	TC66740205	7BCLS-24R
8.3	70	2R	1	50	3.00 (76.2)	Not applicable	15.90 (403.9)	8 (3.63)	TC66700602	TC66700702	TC66740205	8ACLS-2R
	100	3R	1	50	3.00 (76.2)	Not applicable	15.90 (403.9)	8 (3.63)	TC66700602	TC66700702	TC66740205	8ACLS-3R
	130	4R	1	50	3.00 (76.2)	Not applicable	15.90 (403.9)	8 (3.63)	TC66700602	TC66700702	TC66740205	8ACLS-4R
	150	5R	1	50	3.00 (76.2)	Not applicable	15.90 (403.9)	8 (3.63)	TC66700602	TC66700702	TC66740205	8ACLS-5R
	170	6R	1	50	3.00 (76.2)	Not applicable	15.90 (403.9)	8 (3.63)	TC66700602	TC66700702	TC66740205	8ACLS-6R

3.6

Current Limiting Fuses

ACLS, BCLS, CLS, HCLS and NCLS Type Fuses

CLS Type Current Limiting Fuses, continued

Maximum Design Voltage (kV)	Current Rating (Amperes)	"R" Designation	Barrel Number	Interrupting Rating rms (kA Sym.)	Clip Center		Length	Approximate Shipping Weight Lbs (kg)	Performance Curves		Peak Let-Through Current	Catalog Number
					Diameter	Approximate Dimensions in Inches (mm)			Minimum Melting Time	Total Clearing Time		
7.2	200	9R	1	50	3.00 (76.2)	Not applicable	15.90 (403.9)	8 (3.63)	TC66700602	TC66700702	TC66740205	7ACLS-9R
	230	12R	1	50	3.00 (76.2)	Not applicable	15.90 (403.9)	8 (3.63)	TC66700602	TC66700702	TC66740205	7ACLS-12R
	390	18R	2	50	3.00 (76.2)	Not applicable	15.90 (403.9)	17 (7.72)	TC66700602	TC66700702	TC66740205	7ACLS-18R
	450	24R	2	50	3.00 (76.2)	Not applicable	15.90 (403.9)	17 (7.72)	TC66700602	TC66700702	TC66740205	7ACLS-24R
	450	24R	2	50	3.00 (76.2)	Not applicable	15.90 (403.9)	20 (9.08)	TC66700602	TC66700702	TC66740205	7CLS70-24R
	650	36R	3	50	3.00 (76.2)	Not applicable	15.90 (403.9)	30 (13.62)	TC66700602	TC66700702	TC66740205	7CLS70-36R
	700	44R	2	50	4.00 (101.6)	Not applicable	15.90 (403.9)	40 (18.16)	TC66700602	TC66700702	TC66740205	7CLS70-44R
8.3	15	Not applicable	1	50	3.00 (76.2)	14.00 (355.6)	17.90 (454.7)	11 (4.99)	TC66664202	TC66664302	TC66679802	8CLS-15
	30	Not applicable	1	50	3.00 (76.2)	14.00 (355.6)	17.90 (454.7)	11 (4.99)	TC66664202	TC66664302	TC66679802	8CLS-30
	60	Not applicable	1	50	3.00 (76.2)	14.00 (355.6)	17.90 (454.7)	11 (4.99)	TC66664202	TC66664302	TC66679802	8CLS-60
	70	Not applicable	1	50	3.00 (76.2)	14.00 (355.6)	17.90 (454.7)	11 (4.99)	TC66664202	TC66664302	TC66679802	8CLS-70
	90	Not applicable	1	50	3.00 (76.2)	14.00 (355.6)	17.90 (454.7)	11 (4.99)	TC66664202	TC66664302	TC66679802	8CLS-90
	110	Not applicable	1	50	3.00 (76.2)	14.00 (355.6)	17.90 (454.7)	11 (4.99)	TC66664202	TC66664302	TC66679802	8CLS-110
	125	Not applicable	1	50	3.00 (76.2)	14.00 (355.6)	17.90 (454.7)	11 (4.99)	TC66664202	TC66664302	TC66679802	8CLS-125
	150	Not applicable	2	50	3.00 (76.2)	14.00 (355.6)	17.90 (454.7)	22 (9.99)	TC66664202	TC66664302	TC66679802	8CLS-150
	200	Not applicable	2	50	3.00 (76.2)	14.00 (355.6)	17.90 (454.7)	22 (9.99)	TC66664202	TC66664302	TC66679802	8CLS-200
	225	Not applicable	2	50	3.00 (76.2)	14.00 (355.6)	17.90 (454.7)	22 (9.99)	TC66664202	TC66664302	TC66679802	8CLS-225

Dimensions

Approximate Dimensions in Inches (mm)

CLS Type Fuse

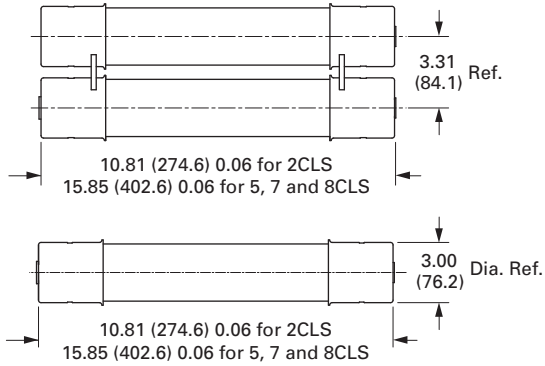

5BCLS and 7BCLS Type Fuses

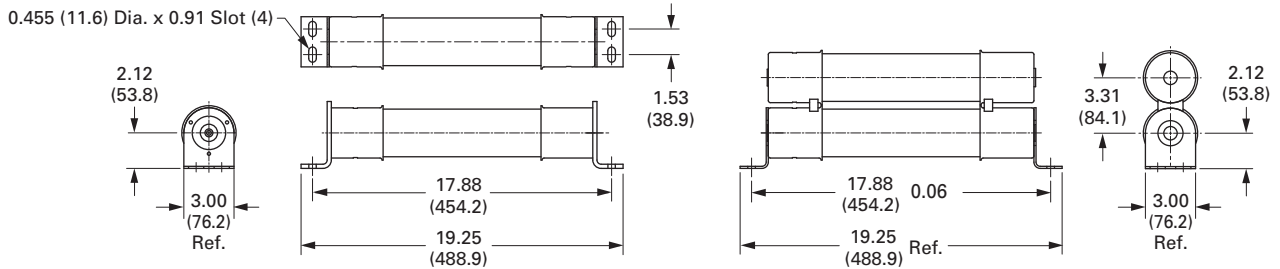

2BCLS Type Fuse

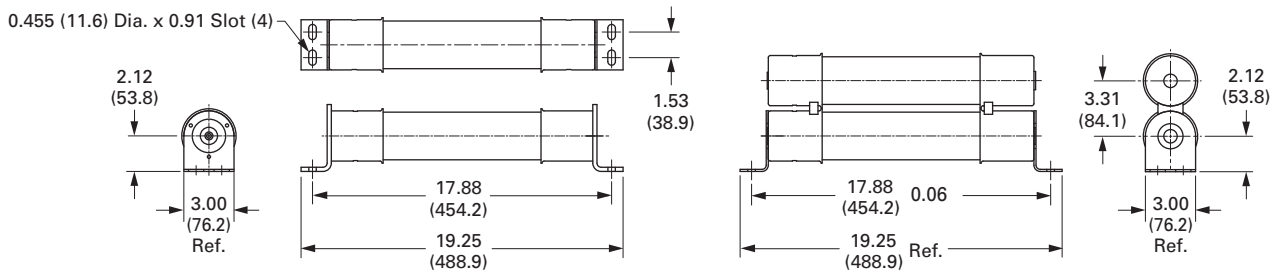

3.6

Current Limiting Fuses

ACLS, BCLS, CLS, HCLS and NCLS Type Fuses

CLS Type Mountings and Hardware

Maximum Design Voltage (kV)	Ampere Rating	Fuse Mounting Type	Voltage BIL (kV)	Mounting (Including Live Parts, End Fittings) ①		Live Parts (Including End Fittings)	End Fittings (Disconnect Only)
				Porcelain Insulator	Glass-Polyester Insulator	Catalog Number	Catalog Number
				Catalog Number	Catalog Number	Catalog Number	Catalog Number
2.54	25–230	Non-disconnect	60	2CLE-PNM-D	2CLE-GNM-D	CLE-NL-D	—
		Disconnect	60	2CLE-PDM-D	2CLE-GDM-E	CLE-DL-D	CLE-DF-D
	390–450	Non-disconnect	60	2CLE-PNM-E	2CLE-GNM-E	CLE-NL-E	—
		Disconnect	60	2CLE-PDM-E	2CLE-GDM-E	CLE-DL-E	CLE-DF-E
5.5 (CLS)	30–230	Non-disconnect	60	5HLE-PNM-D	5HLE-GNM-D	CLE-NL-D	—
		Disconnect	60	5HLE-PDM-D	5HLE-GDM-E	CLE-DL-D	CLE-DF-D
	390–480	Non-disconnect	60	5HLE-PNM-E	5HLE-GNM-E	CLE-NL-E	—
		Disconnect	60	5HLE-PDM-E	5HLE-GDM-E	CLE-DL-E	CLE-DF-E
5.5 (LCLS)	70–230	Non-disconnect	60	5CLE-PNM-D	5CLE-GNM-D	CLE-NL-D	—
		Disconnect	60	5CLE-PDM-D	5CLE-GDM-D	CLE-DL-D	CLE-DF-D
			75	8CLE-PDM-D	8CLE-GDM-D	CLE-DL-D	CLE-DF-D
	390–450	Non-disconnect	60	5CLE-PNM-E	5CLE-GNM-E	CLE-NL-E	—
		Disconnect	60	5CLE-PDM-E	5CLE-GDM-E	CLE-DL-E	CLE-DF-E
			75	8CLE-PDM-E	8CLE-GDM-E	CLE-DL-E	CLE-DF-E
8.3	70–100	Non-disconnect	75	8HLE-PNM-D	8HLE-GNM-D	CLE-NL-D	—
	130–230	Disconnect	75	8HLE-PDM-D	8HLE-GDM-D	CLE-DL-D	CLE-DF-D
7.2	390–450	Non-disconnect	75	8HLE-PDM-E	8HLE-GNM-E	CLE-NL-E	—
		Disconnect	75	8HLE-PDM-E	8HLE-GDM-E	CLE-DL-E	CLE-DF-E
8.3	15–30	Non-disconnect	75	8CLE-PNM-D	8CLE-GNM-D	CLE-NL-D	—
	60–125	Disconnect	75	8CLE-PDM-D	8CLE-GDM-D	CLE-DL-D	CLS-DF-D
	150–225	Non-disconnect	75	8CLE-PNM-E	8CLE-GNM-E	CLE-NL-E	—
		Disconnect	75	8CLE-PDM-E	8CLE-GDM-E	CLE-DL-E	CLE-DF-E

Note

① Disconnect only.

CLT Fuse



Contents

<i>Description</i>	<i>Page</i>
CLT Type Fuses	
Product Selection	V14-T3-66
Dimensions	V14-T3-66

CLT Type Fuses

Applications

Eaton's CLT fuses are designed specifically to provide fault protection on high capacity indoor and underground distribution systems. These general purpose current limiting fuses meet or exceed C37 standards for this class of distribution fuse. CLT fuses may be used in conjunction with EFD load break switches that meet the full switching requirements of underground distribution systems using pad-mounted transformers. In addition, CLT fuses may be applied in pad-mounted transformer drawout wells or in conjunction with LBOR oil switches as a means of low-cost transformer protection.

Fuse Ratings Available

Voltage (kV)	Amperes
2.75	5–150
5.5	8–60
8.3	5–45
14.4	30
15.5	4–18

CLT Features

CLT type current limiting fuses offer a number of desirable advantages. Consider the following during the selection process:

- **Quiet Safe Operation:** CLT fuses are non-indicating and will clear all currents from minimum melting to maximum interrupting rating without any external disturbance or expulsion of gas
- **Limits Fault Current Let-Through:** The let-through current for a high short-circuit fault is limited to a value far below the available peak current because the current is forced to zero before the end of the first half cycle
- **Arc-Voltage Protection:** CLT fuses control the arc voltage that is produced during current limitation to less than three times the normal operating voltage rating
- **Maintains Non-Conductance After Interruption:** Specially designed cores prevent internal flash through when rated voltage remains across the fuse after interruption

- **Low-Cost Transformer Protection:** The CLT fuse can be used in EFD load break switches and dry well drawout holders

Construction and Operation

CLT fuses are constructed with pure silver fuse elements, high purity silica sand fill with controlled grain size, a specially designed core, and a glass-epoxy outer casing.

During a high fault current, the silver element(s) melts almost instantly losing energy to the surrounding sand. The energy melts the sand forming a glass-like substance commonly referred to as "fulgurite." The arc voltage rapidly increases to about three times the fuse voltage rating, forcing the current to zero. The fault current is interrupted in one-half cycle or less without noise or expulsion of gases.

Current limiting action occurs only when the current is above the threshold current for the fuse, that is, the current is high enough to melt the fuse element(s) before the peak value of current is reached in the first half cycle.

Low level currents are cleared by the melting of a tin solder drop on the fuse element that in turn causes the silver element to melt. This is called the M-effect. The silver element then burns back until there is sufficient internal gap to interrupt the current.

Ratings and Selection

When a decision has been made to use current limiting fuses, the minimum amount of information required to make the proper selection is:

- Voltage rating
- Current rating
- Interrupting rating
- Mounting method

See the table on **Page V14-T3-66** for assistance in selecting the correct fuse catalog number.

These types of fuses are designed specifically to provide fault protection on high capacity indoor and underground distribution systems.

3.7

Current Limiting Fuses

CLT Type Fuses

Product Selection

CLT Type Current Limiting Fuses

Maximum Design Voltage (kV)	Current Rating (Amperes)	Catalog Number	Barrel Number	Interrupting Rating rms (kA Sym.)	Approx. Diameter in (mm)	Length (Inches)	Approx. Shipping Weight (Lbs)	Performance Curves		
								Minimum Melting Time	Total Clearing Time	Peak Let-Through Current
2.75	5	2CLT-5	1	25	1.60 (40.6)	9.70 (246.4)	1.25	TC59885801	TC66675901	TC62909001
	12	2CLT-12	1	25	1.60 (40.6)	9.70 (246.4)	1.25			
	18	2CLT-18	1	25	1.60 (40.6)	9.70 (246.4)	1.25			
	25	2CLT-25	1	25	1.60 (40.6)	9.70 (246.4)	1.25			
	30	2CLT-30	1	25	1.60 (40.6)	9.70 (246.4)	1.25			
	75	2CLT-75	1	25	1.60 (40.6)	9.70 (246.4)	1.25			
	90	2CLT-90	1	25	2.25 (57.1)	9.76 (248.0)	2.5			
	150	2CLT-150	1	25	2.25 (57.1)	9.76 (248.0)	2.5			
5.5	8	5CLT-8	1	25	1.60 (40.6)	9.70 (246.4)	1.25	TC59885803	TC66675903	TC62909002
	12	5CLT-12	1	25	1.60 (40.6)	9.70 (246.4)	1.25			
	18	5CLT-18	1	25	1.60 (40.6)	9.70 (246.4)	1.25			
	25	5CLT-25	1	25	1.60 (40.6)	9.70 (246.4)	1.25			
	30	5CLT-30	1	25	2.25 (57.1)	9.76 (248.0)	2.5			
	45	5CLT-45	1	25	2.25 (57.1)	9.76 (248.0)	2.5			
	60	5CLT-60	1	25	2.25 (57.1)	9.76 (248.0)	2.5			
8.3	5	8CLT-5	1	25	1.60 (40.6)	9.70 (246.4)	1.25	TC59885805	TC66675905	TC62909003
	8	8CLT-8	1	25	1.60 (40.6)	9.70 (246.4)	1.25			
	12	8CLT-12	1	25	1.60 (40.6)	9.70 (246.4)	1.25			
	18	8CLT-18	1	25	1.60 (40.6)	9.70 (246.4)	1.25			
	25	8CLT-25	1	25	1.60 (40.6)	9.70 (246.4)	1.25			
	30	8CLT-30	1	25	1.60 (40.6)	11.00 (279.4)	1.25			
	30	8CLT-30	1	25	2.25 (57.1)	9.76 (248.0)	2.5			
	45	8CLT-45	1	25	2.25 (57.1)	9.76 (248.0)	2.5			
15.5	4	15CLT-4	1	25	2.25 (57.1)	9.76 (248.0)	2.5	TC59885701	TC66676001	TC63942701
	5	15CLT-5	1	25	2.25 (57.1)	9.76 (248.0)	2.5			
	8	15CLT-8	1	25	2.25 (57.1)	9.76 (248.0)	2.5			
	12	15CLT-12	1	25	2.25 (57.1)	9.76 (248.0)	2.5			
	18	15CLT-18	1	25	2.25 (57.1)	9.76 (248.0)	2.5			
14.4	30	15CLT-30	1	25	2.25 (57.1)	9.76 (248.0)	2.5	TC59885701	TC66676001	TC63942701

Dimensions

Approximate Dimensions in Inches (mm).

The drawing below specifies certain dimensions and references other dimensions. Refer to the table above for the referenced dimensions of particular CLT type fuses.

CLT Type Fuse

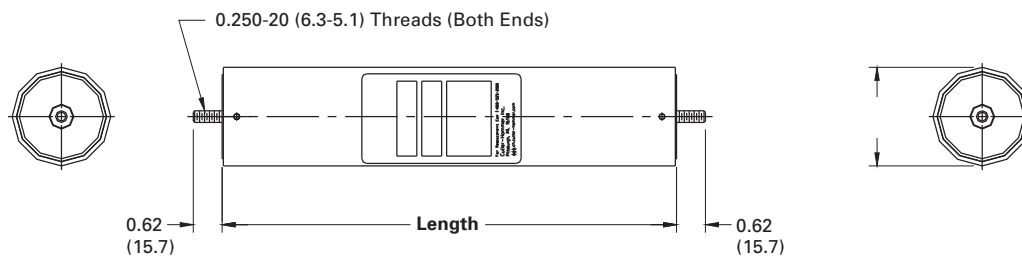

Eaton CX Fuses



Contents

Description	Page
CX, CXI and CXN Type Fuses	
CXN Construction	V14-T3-68
CXN Ratings	V14-T3-68
CX Construction and Operation	V14-T3-68
Product Selection	V14-T3-69
Dimensions	V14-T3-75

CX, CXI and CXN Type Fuses

Applications

Eaton's CX, CXI and CXN general purpose current limiting fuses are designed specifically to provide complete fault protection on high capacity indoor and underground distribution systems. These fuses are C-rated and exceed the requirements of C37 standards for general purpose distribution current limiting fuses.

- Pad-mounted and submersible three-phase and single-phase transformers
- Pad-mounted and submersible switch and fuse units
- Station service protection
- Primary switch and fuse units on mine rectifiers

Note: CXI fuses are not suitable for submersible applications.

CXN fuses are applied in:

- Power transformer protection
- Power centers
- Load interrupters
- Feeder circuit protection
- Mine rectifiers

CX, CXI and CXN Features

CX and CXN type current limiting fuses offer a number of desirable advantages. Consider the following during the selection process:

- **Quiet Safe Operation:** CX and CXN fuses are non-indicating devices—CXI fuses are indicating devices. These fuses will clear all currents from their minimum melting current to their maximum interrupting rating without any external disturbance or expulsion of gas
- **Limits Fault Current Let-Through:** The let-through current for a high short-circuit fault is limited to a value far below the available peak current because the current is forced to zero before the end of the first half cycle
- **Arc-Voltage Protection:** CX and CXN fuses control the arc voltage that is produced during current limitation to less than three times the normal operating voltage rating

- **Maintains Non-Conductance After Interruption:** An inorganic core with spaced arc guards prevent internal flash through when rated voltage remains across the fuse after interruption
- **Fits Many Mountings:** CX and CXN fuses can be used in disconnect and non-disconnect mountings. CX fuses can be used in EFD load break switches through 8.3 kV and dry well drawout fuse holders
- **Interchangeable:** CX and CXI fuses are a direct replacement for competitive general purpose distribution class current limiting fuses

CXN Construction

CXN type fuses are constructed with pure silver fuse elements, high purity silica sand filler with controlled grain size, an inorganic core with spaced arc suppressors, and a glass melamine or glass epoxy outer casing.

The end studs of CXN fuses are identical to the CX type. However, CXN fuses have a much higher C-rating, are longer in physical length and larger in diameter. The diameters are 3 or 4 inches depending on the ratings.

CXN Ratings

The C-rating range is from 60C to 300C at 8.3 kV, with some ratings including 300C being achieved by paralleling two (2) 150C single barrel fuses.

At 15 kV, the ranges are 45C to 175C, with 120C, 150C and 175C being achieved by paralleling single barrel fuses.

The tested and approved parallel ratings are specified in the product selection tables.

CX Construction and Operation

CX and CXI type fuses are constructed with pure silver fuse elements, high purity silica sand filler with controlled grain size, an inorganic core with spaced arc suppressors, and a glass melamine or glass epoxy outer casing.

During a high fault current, the silver element(s) melts almost instantly losing energy to the surrounding sand. The energy melts the sand forming a glass-like substance commonly referred to as "fulgurite." The arc voltage rapidly increases to about three times the fuse voltage rating, forcing the current to zero. The fault current is interrupted in one-half cycle or less without noise or expulsion of gases.

Current limiting action occurs only when the current is above the threshold current for the fuse, that is, the current is high enough to melt the fuse elements) before the peak value of current is reached in the first half cycle.

Low level currents are cleared by the melting of a tin solder drop on the fuse element that in turn causes the silver element to melt. This is called the M-effect. The silver element then burns back until there is sufficient internal gap to interrupt the current.

In some instances where the required C-rating exceeds the limits of CX fuses, it is possible to move the live parts to accommodate the longer CXN fuse, and where space and clearances present no problem, the larger CXN fuse can be substituted for a CX fuse.

Product Selection

CX Type

CX Type



CX Type Current Limiting Fuses 4.3 kV Maximum (2.4 kV Nominal)

Current Rating (Amperes)	Barrel Number	Interrupting Rating rms (kA Sym.)	Fuse Mounting Code	Diameter Approximate Dimensions in Inches (mm)	Length	Approximate Shipping Weight Lbs (kg)	Performance Curves				Catalog Number
							Minimum Melting Time	Total Clearing Time	Peak Let-Through Current	I^2t	
Non-Indicating											
18C	1	50	G	1.13 (28.7)	10.00 (254.0)	1 (0.45)	TC70544101	TC70544501	TC70544901	TC70545101	4CX-18C
25C	1	50	G	1.13 (28.7)	10.00 (254.0)	1 (0.45)	TC70544101	TC70544501	TC70544901	TC70545101	4CX-25C
35C	1	50	G	2.00 (50.8)	10.00 (254.0)	1 (0.45)	TC70544101	TC70544501	TC70544901	TC70545101	4CX-35C
45C	1	50	G	2.00 (50.8)	10.00 (254.0)	2 (0.91)	TC70544101	TC70544501	TC70544901	TC70545101	4CX-45C
50C	1	50	G	2.00 (50.8)	10.00 (254.0)	2 (0.91)	TC70544101	TC70544501	TC70544901	TC70545101	4CX-50C
60C	1	50	G	2.00 (50.8)	10.00 (254.0)	2 (0.91)	TC70544102	TC70544502	TC70544901	TC70545101	4CX-60C
65C	1	50	G	2.00 (50.8)	10.00 (254.0)	2 (0.91)	TC70544102	TC70544501	TC70544901	TC70545101	4CX-65C
75C	1	50	G	2.00 (50.8)	10.00 (254.0)	2 (0.91)	TC70544102	TC70544501	TC70544901	TC70545101	4CX-75C
80C	1	50	G	2.00 (50.8)	10.00 (254.0)	2 (0.91)	TC70544102	TC70544502	TC70544901	TC70545101	4CX-80C
100C	1	50	G	2.00 (50.8)	10.00 (254.0)	2 (0.91)	TC70544102	TC70544501	TC70544901	TC70545101	4CX-100C
Indicating											
18C	1	50	G	1.13 (28.7)	10.00 (254.0)	1 (0.45)	TC70544101	TC70544501	TC70544901	TC70545101	4CXI-18C
25C	1	50	G	1.13 (28.7)	10.00 (254.0)	1 (0.45)	TC70544101	TC70544501	TC70544901	TC70545101	4CXI-25C
35C	1	50	G	2.00 (50.8)	10.00 (254.0)	1 (0.45)	TC70544101	TC70544501	TC70544901	TC70545101	4CXI-35C
45C	1	50	G	2.00 (50.8)	10.00 (254.0)	2 (0.91)	TC70544101	TC70544501	TC70544901	TC70545101	4CXI-45C
50C	1	50	G	2.00 (50.8)	10.00 (254.0)	2 (0.91)	TC70544101	TC70544501	TC70544901	TC70545101	4CXI-50C
60C	1	50	G	2.00 (50.8)	10.00 (254.0)	2 (0.91)	TC70544102	TC70544502	TC70544901	TC70545101	4CXI-60C
65C	1	50	G	2.00 (50.8)	10.00 (254.0)	2 (0.91)	TC70544102	TC70544501	TC70544901	TC70545101	4CXI-65C
75C	1	50	G	2.00 (50.8)	10.00 (254.0)	2 (0.91)	TC70544102	TC70544501	TC70544901	TC70545101	4CXI-75C
80C	1	50	G	2.00 (50.8)	10.00 (254.0)	2 (0.91)	TC70544102	TC70544502	TC70544901	TC70545101	4CXI-80C
100C	1	50	G	2.00 (50.8)	10.00 (254.0)	2 (0.91)	TC70544102	TC70544501	TC70544901	TC70545101	4CXI-100C

CX Type Mountings and Hardware 4.3 kV Maximum (2.4 kV Nominal)

Ampere Rating	Fuse Mounting Type ^①	Size	Voltage BIL (kV)	Mounting (Including Live Parts, End Fittings) ^②		Live Parts (Including End Fittings) ^②	End Fittings (Disconnect Only)
				Porcelain Insulator Catalog Number	Glass-Polyester Insulator Catalog Number		
18C–100C	Non-disconnect	A	60	—	5CX-GNM-G	CX-NL	—
	Disconnect	A	60	—	5CX-GDM-G	CX-DL	CX-DF

Notes

- ^① See Page V14-T3-38 for diagram of typical mounting.
- ^② End fittings supplied only when required.

CX Type



3

CX Type Current Limiting Fuses 5.5 kV Maximum (4.8 kV Nominal)

Current Rating (Amperes)	Barrel Number	Interrupting Rating rms (kA Sym.)	Fuse Mounting Code	Diameter	Length	Approximate Shipping Weight Lbs (kg)	Performance Curves			Catalog Number	
				Approximate Dimensions in Inches (mm)	Minimum Melting Time		Total Clearing Time	Peak Let-Through Current	I^2t		
Non-Indicating											
10C	1	50	G	1.13 (28.7)	10.00 (254.0)	1 (0.45)	TC70544201	TC70544601	TC70544902	TC70545201	5CX-10C
12C	1	50	G	1.13 (28.7)	10.00 (254.0)	1 (0.45)	TC70544201	TC70544601	TC70544902	TC70545201	5CX-12C
18C	1	50	G	1.13 (28.7)	10.00 (254.0)	1 (0.45)	TC70544201	TC70544601	TC70544902	TC70545201	5CX-18C
20C	1	50	G	1.13 (28.7)	10.00 (254.0)	1 (0.45)	TC70544201	TC70544601	TC70544902	TC70545201	5CX-20C
21C	1	50	G	2.00 (50.8)	10.00 (254.0)	2 (0.91)	TC70544202	TC70544602	TC70544902	TC70545201	5CX-21C
25C	1	50	G	2.00 (50.8)	10.00 (254.0)	2 (0.91)	TC70544201	TC70544601	TC70544902	TC70545201	5CX-25C
30C	1	50	G	1.13 (28.7)	10.00 (254.0)	1 (0.45)	TC70544201	TC70544601	TC70544902	TC70545201	5CX-30C
35C	1	50	G	2.00 (50.8)	10.00 (254.0)	2 (0.91)	TC70544202	TC70544602	TC70544902	TC70545201	5CX-35C
40C	1	50	G	2.00 (50.8)	10.00 (254.0)	2 (0.91)	TC70544201	TC70544601	TC70544902	TC70545201	5CX-40C
50C	1	50	G	2.00 (50.8)	10.00 (254.0)	2 (0.91)	TC70544201	TC70544601	TC70544902	TC70545201	5CX-50C
60C	1	50	G	2.00 (50.8)	10.00 (254.0)	2 (0.91)	TC70544202	TC70544602	TC70544902	TC70545201	5CX-60C
65C	1	50	G	2.00 (50.8)	10.00 (254.0)	2 (0.91)	TC70544201	TC70544601	TC70544902	TC70545201	5CX-65C
75C	1	50	G	2.00 (50.8)	10.00 (254.0)	2 (0.91)	TC70544201	TC70544601	TC70544902	TC70545201	5CX-75C
Indicating											
10C	1	50	G	1.13 (28.7)	10.00 (254.0)	1 (0.45)	TC70544201	TC70544601	TC70544902	TC70545201	5CXI-10C
12C	1	50	G	1.13 (28.7)	10.00 (254.0)	1 (0.45)	TC70544201	TC70544601	TC70544902	TC70545201	5CXI-12C
18C	1	50	G	1.13 (28.7)	10.00 (254.0)	1 (0.45)	TC70544201	TC70544601	TC70544902	TC70545201	5CXI-18C
20C	1	50	G	1.13 (28.7)	10.00 (254.0)	1 (0.45)	TC70544201	TC70544601	TC70544902	TC70545201	5CXI-20C
21C	1	50	G	2.00 (50.8)	10.00 (254.0)	2 (0.91)	TC70544202	TC70544602	TC70544902	TC70545201	5CXI-21C
25C	1	50	G	2.00 (50.8)	10.00 (254.0)	2 (0.91)	TC70544201	TC70544601	TC70544902	TC70545201	5CXI-25C
30C	1	50	G	1.13 (28.7)	10.00 (254.0)	1 (0.45)	TC70544201	TC70544601	TC70544902	TC70545201	5CXI-30C
35C	1	50	G	2.00 (50.8)	10.00 (254.0)	2 (0.91)	TC70544202	TC70544602	TC70544902	TC70545201	5CXI-35C
40C	1	50	G	2.00 (50.8)	10.00 (254.0)	2 (0.91)	TC70544201	TC70544601	TC70544902	TC70545201	5CXI-40C
50C	1	50	G	2.00 (50.8)	10.00 (254.0)	2 (0.91)	TC70544201	TC70544601	TC70544902	TC70545201	5CXI-50C
60C	1	50	G	2.00 (50.8)	10.00 (254.0)	2 (0.91)	TC70544202	TC70544602	TC70544902	TC70545201	5CXI-60C
65C	1	50	G	2.00 (50.8)	10.00 (254.0)	2 (0.91)	TC70544201	TC70544601	TC70544902	TC70545201	5CXI-65C
75C	1	50	G	2.00 (50.8)	10.00 (254.0)	2 (0.91)	TC70544201	TC70544601	TC70544902	TC70545201	5CXI-75C

CX Type Mountings and Hardware 5.5 kV Maximum (4.8 kV Nominal)

Ampere Rating	Fuse Mounting Type ^①	Size	Voltage BIL (kV)	Mounting (Including Live Parts, End Fittings) ^②		Live Parts (Including End Fittings) ^②	End Fittings (Disconnect Only)
				Porcelain Insulator Catalog Number	Glass-Polyester Insulator Catalog Number	Catalog Number	Catalog Number
10C-75C	Non-disconnect	A	60	—	5CX-GNM-G	CX-NL	—
	Disconnect	A	60	—	5CX-GDM-G	CX-DL	CX-DF

Notes

- ① See Page V14-T3-38 for diagram of typical mounting.
- ② End fittings supplied only when required.

CX Type



CX Type Current Limiting Fuses 8.3 kV Maximum (7.2 kV Nominal)

Current Rating (Amperes)	Barrel Number	Interrupting Rating rms (kA Sym.)	Fuse Mounting Code	Diameter	Length	Approximate Shipping Weight Lbs (kg)	Performance Curves			Catalog Number	
				Approximate Dimensions in Inches (mm)			Minimum Melting Time	Total Clearing Time	Peak Let-Through Current		I^2t
Non-Indicating											
3.5C	1	50	G	1.13 (28.7)	10.00 (254.0)	2 (0.91)	TC70544302	TC70544702	TC70545001	TC70545301	8CX-3.5C
4C	1	50	G	1.13 (28.7)	10.00 (254.0)	2 (0.91)	TC70544302	TC70544702	TC70545001	TC70545301	8CX-4C
4.5C	1	50	G	1.13 (28.7)	10.00 (254.0)	2 (0.91)	TC70544301	TC70544701	TC70545001	TC70545301	8CX-4.5C
6C	1	50	G	1.13 (28.7)	10.00 (254.0)	2 (0.91)	TC70544301	TC70544701	TC70545001	TC70545301	8CX-6C
7C	1	50	G	1.13 (28.7)	10.00 (254.0)	2 (0.91)	TC70544302	TC70544702	TC70545001	TC70545301	8CX-7C
8C	1	50	G	1.13 (28.7)	10.00 (254.0)	2 (0.91)	TC70544301	TC70544701	TC70545001	TC70545301	8CX-8C
10C	1	50	G	1.13 (28.7)	10.00 (254.0)	2 (0.91)	TC70544301	TC70544701	TC70545001	TC70545301	8CX-10C
12C	1	50	G	1.13 (28.7)	10.00 (254.0)	2 (0.91)	TC70544301	TC70544701	TC70545001	TC70545301	8CX-12C
15C	1	50	G	1.13 (28.7)	10.00 (254.0)	2 (0.91)	TC70544302	TC70544702	TC70545001	TC70545301	8CX-15C
18C	1	50	G	2.00 (50.8)	10.00 (254.0)	2 (0.91)	TC70544301	TC70544701	TC70545001	TC70545301	8CX-18C
20C	1	50	G	2.00 (50.8)	10.00 (254.0)	2 (0.91)	TC70544301	TC70544701	TC70545001	TC70545301	8CX-20C
25C	1	50	G	2.00 (50.8)	10.00 (254.0)	2 (0.91)	TC70544301	TC70544701	TC70545001	TC70545301	8CX-25C
30C	1	50	G	2.00 (50.8)	10.00 (254.0)	2 (0.91)	TC70544301	TC70544701	TC70545001	TC70545301	8CX-30C
35C	1	50	G	2.00 (50.8)	10.00 (254.0)	2 (0.91)	TC70544302	TC70544702	TC70545001	TC70545301	8CX-35C
40C	1	50	G	2.00 (50.8)	10.00 (254.0)	2 (0.91)	TC70544301	TC70544701	TC70545001	TC70545301	8CX-40C
Indicating											
3.5C	1	50	G	1.13 (28.7)	10.00 (254.0)	2 (0.91)	TC70544302	TC70544702	TC70545001	TC70545301	8CXI-3.5C
4C	1	50	G	1.13 (28.7)	10.00 (254.0)	2 (0.91)	TC70544302	TC70544702	TC70545001	TC70545301	8CXI-4C
4.5C	1	50	G	1.13 (28.7)	10.00 (254.0)	2 (0.91)	TC70544301	TC70544701	TC70545001	TC70545301	8CXI-4.5C
6C	1	50	G	1.13 (28.7)	10.00 (254.0)	2 (0.91)	TC70544301	TC70544701	TC70545001	TC70545301	8CXI-6C
7C	1	50	G	1.13 (28.7)	10.00 (254.0)	2 (0.91)	TC70544302	TC70544702	TC70545001	TC70545301	8CXI-7C
8C	1	50	G	1.13 (28.7)	10.00 (254.0)	2 (0.91)	TC70544301	TC70544701	TC70545001	TC70545301	8CXI-8C
10C	1	50	G	1.13 (28.7)	10.00 (254.0)	2 (0.91)	TC70544301	TC70544701	TC70545001	TC70545301	8CXI-10C
12C	1	50	G	1.13 (28.7)	10.00 (254.0)	2 (0.91)	TC70544301	TC70544701	TC70545001	TC70545301	8CXI-12C
15C	1	50	G	1.13 (28.7)	10.00 (254.0)	2 (0.91)	TC70544302	TC70544702	TC70545001	TC70545301	8CXI-15C
18C	1	50	G	2.00 (50.8)	10.00 (254.0)	2 (0.91)	TC70544301	TC70544701	TC70545001	TC70545301	8CXI-18C
20C	1	50	G	2.00 (50.8)	10.00 (254.0)	2 (0.91)	TC70544301	TC70544701	TC70545001	TC70545301	8CXI-20C
25C	1	50	G	2.00 (50.8)	10.00 (254.0)	2 (0.91)	TC70544301	TC70544701	TC70545001	TC70545301	8CXI-25C
30C	1	50	G	2.00 (50.8)	10.00 (254.0)	2 (0.91)	TC70544301	TC70544701	TC70545001	TC70545301	8CXI-30C
35C	1	50	G	2.00 (50.8)	10.00 (254.0)	2 (0.91)	TC70544302	TC70544702	TC70545001	TC70545301	8CXI-35C
40C	1	50	G	2.00 (50.8)	10.00 (254.0)	2 (0.91)	TC70544301	TC70544701	TC70545001	TC70545301	8CXI-40C

CX Type Mountings and Hardware 8.3 kV Maximum (7.2 kV Nominal)

Ampere Rating	Fuse Mounting Type ^①	Size	Voltage BIL (kV)	Mounting (Including Live Parts, End Fittings) ^②		Live Parts (Including End Fittings) ^②	End Fittings (Disconnect Only)
				Porcelain Insulator Catalog Number	Glass-Polyester Insulator Catalog Number		
3.5C-40C	Non-disconnect	B	75	—	8CX-GNM-G	CX-NL	—
	Disconnect	B	75	—	8CX-GDM-G	CX-DL	CX-DF

Notes

- ① See Page V14-T3-38 for diagram of typical mounting.
- ② End fittings supplied only when required.

CX Type



3

CX Type Current Limiting Fuses 15.5 kV Maximum (14.4 kV Nominal)

Current Rating (Amperes)	Barrel Number	Interrupting Rating rms (kA Sym.)	Fuse Mounting Code	Diameter	Length	Approximate Shipping Weight Lbs (kg)	Performance Curves			Catalog Number	
				Approximate Dimensions in Inches (mm)	Minimum Melting Time		Total Clearing Time	Peak Let-Through Current	I^2t		
Non-Indicating											
4C	1	50	G	2.00 (50.8)	14.30 (363.2)	2 (0.91)	TC70544401	TC70544801	TC70545002	TC70545401	15CX-4C
6C	1	50	G	2.00 (50.8)	14.30 (363.2)	2 (0.91)	TC70544401	TC70544801	TC70545002	TC70545401	15CX-6C
7C	1	50	G	2.00 (50.8)	14.30 (363.2)	2 (0.91)	TC70544402	TC70544802	TC70545002	TC70545401	15CX-7C
8C	1	50	G	2.00 (50.8)	14.30 (363.2)	2 (0.91)	TC70544401	TC70544801	TC70545002	TC70545401	15CX-8C
10C	1	50	G	2.00 (50.8)	14.30 (363.2)	2 (0.91)	TC70544401	TC70544801	TC70545002	TC70545401	15CX-10C
12C	1	50	G	2.00 (50.8)	14.30 (363.2)	2 (0.91)	TC70544401	TC70544801	TC70545002	TC70545401	15CX-12C
15C	1	50	G	2.00 (50.8)	14.30 (363.2)	2 (0.91)	TC70544402	TC70544802	TC70545002	TC70545401	15CX-15C
18C	1	50	G	2.00 (50.8)	14.30 (363.2)	2 (0.91)	TC70544401	TC70544801	TC70545002	TC70545401	15CX-18C
20C	1	50	G	2.00 (50.8)	14.30 (363.2)	2 (0.91)	TC70544401	TC70544801	TC70545002	TC70545401	15CX-20C
25C	1	50	G	2.00 (50.8)	14.30 (363.2)	2 (0.91)	TC70544401	TC70544801	TC70545002	TC70545401	15CX-25C
30C	1	50	G	2.00 (50.8)	14.30 (363.2)	2 (0.91)	TC70544401	TC70544801	TC70545002	TC70545401	15CX-30C
40C	1	50	G	2.00 (50.8)	14.30 (363.2)	2 (0.91)	TC70544401	TC70544801	TC70545002	TC70545401	15CX-40C
Indicating											
4C	1	50	G	2.00 (50.8)	14.30 (363.2)	2 (0.91)	TC70544401	TC70544801	TC70545002	TC70545401	15CXI-4C
6C	1	50	G	2.00 (50.8)	14.30 (363.2)	2 (0.91)	TC70544401	TC70544801	TC70545002	TC70545401	15CXI-6C
7C	1	50	G	2.00 (50.8)	14.30 (363.2)	2 (0.91)	TC70544402	TC70544802	TC70545002	TC70545401	15CXI-7C
8C	1	50	G	2.00 (50.8)	14.30 (363.2)	2 (0.91)	TC70544401	TC70544801	TC70545002	TC70545401	15CXI-8C
10C	1	50	G	2.00 (50.8)	14.30 (363.2)	2 (0.91)	TC70544401	TC70544801	TC70545002	TC70545401	15CXI-10C
12C	1	50	G	2.00 (50.8)	14.30 (363.2)	2 (0.91)	TC70544401	TC70544801	TC70545002	TC70545401	15CXI-12C
15C	1	50	G	2.00 (50.8)	14.30 (363.2)	2 (0.91)	TC70544402	TC70544802	TC70545002	TC70545401	15CXI-15C
18C	1	50	G	2.00 (50.8)	14.30 (363.2)	2 (0.91)	TC70544401	TC70544801	TC70545002	TC70545401	15CXI-18C
20C	1	50	G	2.00 (50.8)	14.30 (363.2)	2 (0.91)	TC70544401	TC70544801	TC70545002	TC70545401	15CXI-20C
25C	1	50	G	2.00 (50.8)	14.30 (363.2)	2 (0.91)	TC70544401	TC70544801	TC70545002	TC70545401	15CXI-25C
30C	1	50	G	2.00 (50.8)	14.30 (363.2)	2 (0.91)	TC70544401	TC70544801	TC70545002	TC70545401	15CXI-30C
40C	1	50	G	2.00 (50.8)	14.30 (363.2)	2 (0.91)	TC70544401	TC70544801	TC70545002	TC70545401	15CXI-40C

CX Type Mountings and Hardware 15.5 kV Maximum (14.4 kV Nominal)

Ampere Rating	Fuse Mounting Type ①	Size	Voltage BIL (kV)	Mounting (Including Live Parts, End Fittings) ②		Live Parts (Including End Fittings) ②	End Fittings (Disconnect Only)
				Porcelain Insulator Catalog Number	Glass-Polyester Insulator Catalog Number		
4C-40C	Non-disconnect	C	95	—	15CX-GNM-G	CX-NL	—
	Disconnect	C	95	—	15CX-GDM-G	CX-DL	CX-DF

Notes

- ① See Page V14-T3-38 for diagram of typical mounting.
- ② End fittings supplied only when required.

CXN Type

Type CXN



CXN Type Current Limiting Fuses 8.3 kV Maximum (7.2 kV Nominal)

Current Rating (Amperes)	Barrel Number	Interrupting Rating rms (kA Sym.)	Diameter	Length	Approximate Shipping Weight Lbs (kg)	Performance Curves			Catalog Number
			Approximate Dimensions in Inches (mm)	Minimum Melting Time		Total Clearing Time	Peak Let-Through Current		
60C	1	50	3.00 (76.2)	18.80 (477.5)	8 (3.63)	TC66675102	TC66675202	TC66664902	8CXN-60C
100C	1	50	3.00 (76.2)	18.80 (477.5)	8 (3.63)	TC66675102	TC66675202	TC66664902	8CXN-100C
125C	1	50	4.00 (101.6)	18.80 (477.5)	14 (6.36)	TC66675102	TC66675202	TC66664902	8CXN-125C
150C	1	50	4.00 (101.6)	18.80 (477.5)	14 (6.36)	TC66675102	TC66675202	TC66664902	8CXN-150C
200C	1	50	4.00 (101.6)	18.80 (477.5)	14 (6.36)	TC66675102	TC66675202	TC66664902	8CXN-200C
250C	1	50	4.00 (101.6)	18.80 (477.5)	14 (6.36)	TC66675102	TC66675202	TC66664902	8CXN-250C
120C	2	50	3.00 (76.2)	18.80 (477.5)	16 (7.26)	TC66675104	TC66675204	TC66664902	2 X 60C 8CXN-120C
200C	2	50	3.00 (76.2)	18.80 (477.5)	16 (7.26)	TC66675104	TC66675204	TC66664902	2 X 100C 8CXN-200C
250C	2	50	3.00 (76.2)	18.80 (477.5)	16 (7.26)	TC66675104	TC66675204	TC66664902	2 X 125C 8CXN-250C
300C	2	50	4.00 (101.6)	18.80 (477.5)	28 (12.71)	TC66675104	TC66675204	TC66664902	2 X 150C 8CXN-300C

CXN Type Mountings and Hardware 8.3 kV Maximum (7.2 kV Nominal)

Ampere Rating	Fuse Mounting Type ①	Voltage LIWL (BIL)	Glass Polyester Insulator Mounting (Including Live Parts, End Fittings) ② Catalog Number	Live Parts ② Catalog Number	End Fittings (Disconnect Only) Catalog Number
60C–100C Single barrel	Non-disconnect	95	15CXN-GNM-D	15CXN-NL-D	—
	Non-disconnect	95	15CXN-GNM-G	15CXN-NL-G	—
	Disconnect	95	15CXN-GDM-G	15CXN-DL-G	15CXN-DF-G
125C–250C Single barrel	Non-disconnect	95	15CXN-GNM-F	15CXN-NL-F	—
	Non-disconnect	95	15CXN-GNM-G	15CXN-NL-G	—
	Disconnect	95	25CXN-GDM-G	15CXN-DL-G	15CXN-DF-G
120C, 200C Double barrel	Non-disconnect	95	15CXN-GNM-D	15CXN-NL-D	—
250C, 300C Double barrel	Non-disconnect	95	15CXN-GNM-F	15CXN-NL-F	—

Notes

- ① See Page V14-T3-38 for diagram of typical mounting.
- ② End fittings supplied only when required.

CXN Type



3

CXN Type Current Limiting Fuses 15.5 kV Maximum (14.4 kV Nominal)

Current Rating (Amperes)	Barrel Number	Interrupting Rating rms (kA Sym.)	Diameter		Length	Approximate Shipping Weight Lbs (kg)	Performance Curves			Catalog Number
			Approximate Dimensions in Inches (mm)				Minimum Melting Time	Total Clearing Time	Peak Let-Through Current	
45C	1	50	3.00 (76.2)	18.80 (477.5)	8 (3.63)	TC66674802	TC66675002	TC66665002	15CXN-45C	
60C	1	50	3.00 (76.2)	18.80 (477.5)	8 (3.63)	TC66674802	TC66675002	TC66665002	15CXN-60C	
75C	1	50	4.00 (101.6)	18.80 (477.5)	14 (6.36)	TC66674802	TC66675002	TC66665002	15CXN-75C	
85C	1	50	4.00 (101.6)	18.80 (477.5)	14 (6.36)	TC66674802	TC66675002	TC66665002	15CXN-85C	
100C	1	50	4.00 (101.6)	18.80 (477.5)	14 (6.36)	TC66674802	TC66675002	TC66665002	15CXN-100C	
90C	2	50	3.00 (76.2)	18.80 (477.5)	16 (7.26)	TC66674804	TC66675004	TC66665002	2 X 45C 15CXN-90C	
120C	2	50	3.00 (76.2)	18.80 (477.5)	16 (7.26)	TC66674804	TC66675004	TC66665002	2 X 60C 15CXN-120C	
150C	2	50	4.00 (101.6)	18.80 (477.5)	28 (12.71)	TC66674804	TC66675004	TC66665002	2 X 75C 15CXN-150C	
175C	2	50	4.00 (101.6)	18.80 (477.5)	28 (12.71)	TC66674804	TC66675004	TC66665002	2 X 85C 15CXN-175C	

CXN Type Mountings and Hardware 15.5 kV Maximum (14.4 kV Nominal)

Ampere Rating	Fuse Mounting Type ①	Voltage LIWL (BIL)	Glass Polyester Insulator Mounting (Including Live Parts, End Fittings) ② Catalog Number	Live Parts ② Catalog Number	End Fittings (Disconnect Only) Catalog Number
45C–60C Single barrel	Non-disconnect	95	15CXN-GNM-D	15CXN-NL-D	—
	Non-disconnect	95	15CXN-GNM-G	15CXN-NL-G	—
	Disconnect	95	15CXN-GDM-G	15CXN-DL-G	15CXN-DF-G
75C–100C Single barrel	Non-disconnect	95	15CXN-GNM-F	15CXN-NL-F	—
	Non-disconnect	95	15CXN-GNM-G	15CXN-NL-G	—
	Disconnect	95	25CXN-GDM-G	15CXN-DL-G	15CXN-DF-G
90C, 120C Double barrel	Non-disconnect	95	15CXN-GNM-D	15CXN-NL-D	—
150C, 175C Double barrel	Non-disconnect	95	15CXN-GNM-F	15CXN-NL-F	—

Notes

① See Page V14-T3-38 for diagram of typical mounting.

② End fittings supplied only when required.

Dimensions

Approximate Dimensions in Inches (mm).

CXN Type Fuse

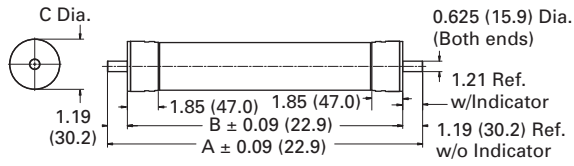

CXN Type Fuse Dimensional Details

Maximum kV	Ampere Rating	Dimensions		
		A	B	C
8.3	60-100	18.86 (479.0)	16.41 (416.8)	3.00 (76.2)
8.3	125-250	18.86 (479.0)	16.41 (416.8)	4.00 (101.6)
15.5	45-60	18.86 (479.0)	18.86 (479.0)	3.00 (76.2)
15.5	75-100	18.86 (479.0)	18.86 (479.0)	4.00 (101.6)

CX Type Fuse

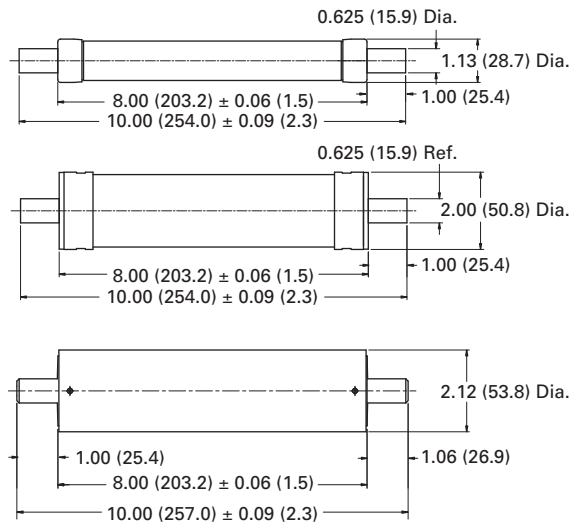

3.9

Current Limiting Fuses

DSL, MDSL and NPL Type Low Voltage Current Limiters

DSL Current Limiters

3

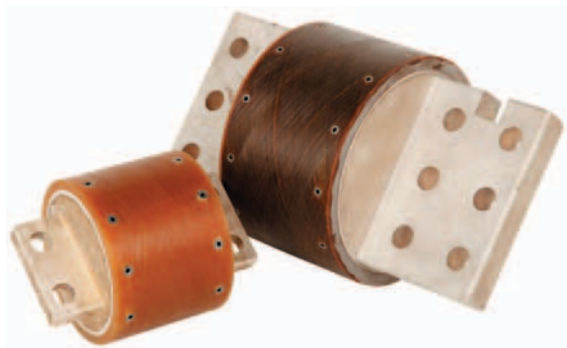

Contents

Description

Page

DSL, MDSL and NPL Type Low Voltage Current Limiters

Product Selection **V14-T3-77**

DSL, MDSL and NPL Type Low Voltage Current Limiters

Product Description

Refer to DSL, Magnum™ DSL or NPL sections of this catalog for product description and application guidelines.

DSL, MDSL and NPL Type Low Voltage Current Limiters

Product Selection

The following current limiters are available as renewal/replacement parts for use in conjunction with DLL, MDSL low voltage power circuit breakers, and network protectors.

Types DSL, MDSL and NPL

Maximum Design Voltage	Interrupting Rating (kA Sym.)	Catalog Number	Style Number	Approx. Shipping Weight Lbs (kg)	Average Melting Time	Peak Let-Through Current
600	200	6DSL-A150	140D816G01	3.00 (1.4)	TC63977102	TC63977202
600	200	6DSL-A200	140D816G02	3.00 (1.4)	TC63977102	TC63977202
600	200	6DSL-A250	140D816G03	3.00 (1.4)	TC63977102	TC63977202
600	200	6DSL-A300	140D816G04	3.00 (1.4)	TC63977102	TC63977202
600	200	6DSL-A400	140D816G05	3.00 (1.4)	TC63977102	TC63977202
600	200	6DSL-A600	140D816G06	3.00 (1.4)	TC63977102	TC63977202
600	200	6DSL-A800	140D816G07	3.00 (1.4)	TC63977102	TC63977202
600	200	6DSL-B1200	140D816G10	4.00 (1.8)	TC63977102	TC63977202
600	200	6DSL-B1600	140D816G11	4.00 (1.8)	TC63977102	TC63977202
600	200	6DSL-B3000	140D816G12	4.00 (1.8)	TC63977102	TC63977202
600	200	6DSL-C800	151D982G01	5.50 (2.5)	TC63943102	TC63943202
600	200	6DSL-C1000	151D982G02	5.50 (2.5)	TC63943102	TC63943202
600	200	6DSL-C1200	151D982G03	5.50 (2.5)	TC63943102	TC63943202
600	200	6DSL-C1600	151D982G04	5.50 (2.5)	TC63943102	TC63943202
600	200	6DSL-C2000	151D982G05	5.50 (2.5)	TC63943102	TC63943202
600	200	6DSL-D2500	151D982G09	8.50 (3.9)	TC63943102	TC63943202
600	200	6DSL-D3000	151D982G10	8.50 (3.9)	TC63943102	TC63943202
600	200	6DSL-E2500	5980C01G01	20.0 (9.1)	TC70550302	TC70550402
600	200	6DSL-E3000	5980C01G02	20.0 (9.1)	TC70550302	TC70550402
600	200	6DSL-E4000	5980C01G03	20.0 (9.1)	TC70550302	TC70550402
600	200	6DSL-F5000	5980C01G04	24.0 (10.9)	TC70550302	TC70550402
600	200	6MDSL-MA150	5982C90G01	3.00 (1.4)	TC63977103	TC63977202
600	200	6MDSL-MA200	5982C90G02	3.00 (1.4)	TC63977103	TC63977202
600	200	6MDSL-MA250	5982C90G03	3.00 (1.4)	TC63977103	TC63977203
600	200	6MDSL-MA300	5982C90G04	3.00 (1.4)	TC63977103	TC63977203
600	200	6MDSL-MA400	5982C90G05	3.00 (1.4)	TC63977103	TC63977203
600	200	6MDSL-MA600	5982C90G07	3.00 (1.4)	TC63977103	TC63977203
600	200	6MDSL-MA800	5982C90G08	3.00 (1.4)	TC63977103	TC63977203
600	200	6MDSL-MB-1200	5981C91G01	4.00 (1.8)	TC63977103	TC63977203
600	200	6MDSL-MB-1600	5981C91G02	4.00 (1.8)	TC63977103	TC63977203
600	200	6MDSL-MB-2000	5981C91G03	4.00 (1.8)	TC63977103	TC63977203
600	200	6MDSL-MC-800	5981C92G01	5.50 (2.5)	TC63943102	TC63943202
600	200	6MDSL-MC-1000	5981C92G02	5.50 (2.5)	TC63943102	TC63943202
600	200	6MDSL-MC-1200	5981C92G03	5.50 (2.5)	TC63943102	TC63943202
600	200	6MDSL-MC-1600	5981C92G04	5.50 (2.5)	TC63943102	TC63943202
600	200	6MDSL-MC-2000	5981C92G05	5.50 (2.5)	TC63943102	TC63943202
600	200	6MDSL-MD2500	5981C93G01	8.50 (3.9)	TC63977103	TC63977203
600	200	6MDSL-MD3000	5981C93G02	8.50 (3.9)	TC63977103	TC63977203
480	150	4NPL-900	140D318G04	—	TC63942802	TC63942803
480	150	4NPL-1300	140D318G05	—	TC63942803	TC63942803
480	150	4NPL-1875	140D318G01	—	TC63942804	TC63942803
480	150	4NPL-2000	140D318G07	—	TC63942805	TC63942803
480	150	4NPL-2825	140D318G02	—	TC63942806	TC63942803
480	150	4NPL-3000	140D318G06	—	TC63942807	TC63942803
480	200	4NPL-3500	5982C64G01	—	TC70550306	—
480	200	4NPL-5000	5982C64G02	—	TC70550306	—

Eaton Terms & Conditions

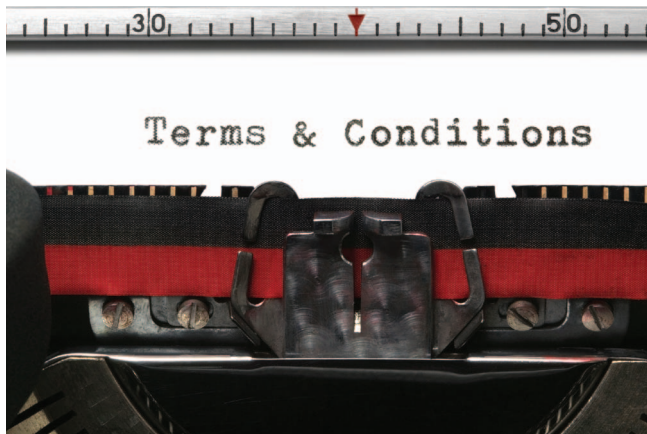

Contents

<i>Description</i>	<i>Page</i>
Terms and Conditions of Sale	V14-A1-1
Terms of Payment	V14-A1-2
Freight	V14-A1-3
Warranty	V14-A1-3

Selling Policy (Supersedes Selling Policy 25-000, dated February 20, 2006)

Terms and Conditions of Sale

The Terms and Conditions of Sale set forth herein, and any supplements which may be attached hereto, constitute the full and final expression of the contract for the sale of products or services (hereinafter referred to as Product(s) or Services by Eaton Corporation (hereinafter referred to as Seller) to the Buyer, and supersedes all prior quotations, purchase orders, correspondence or communications whether written or oral between the Seller and the Buyer. Notwithstanding any contrary language in the Buyer's purchase order, correspondence or other form of acknowledgment, Buyer shall be bound by these Terms and Conditions of Sale when it sends a purchase order or otherwise indicates acceptance of this contract, or when it accepts delivery from Seller of the Products or Services.

THE CONTRACT FOR SALE OF THE PRODUCTS OR SERVICES IS EXPRESSLY LIMITED TO THE TERMS AND CONDITIONS OF SALE STATED HEREIN. ANY ADDITIONAL OR DIFFERENT TERMS PROPOSED BY BUYER ARE REJECTED UNLESS EXPRESSLY AGREED TO IN WRITING BY SELLER. No contract shall exist except as herein provided.

Complete Agreement

No amendment or modification hereto nor any statement, representation or warranty not contained herein shall be binding on the Seller unless made in writing by an authorized representative of the Seller. Prior dealings, usage of the trade or a course of performance shall not be relevant to determine the meaning of this contract even though the accepting or acquiescing party had knowledge of the nature of the performance and opportunity for objection.

Quotations

Written quotations are valid for 30 days from its date unless otherwise stated in the quotation or terminated sooner by notice.

Verbal quotations, unless accepted, expire the same day they are made.

A complete signed order must be received by Seller within 20 calendar days of notification of award, otherwise the price and shipment will be subject to re-negotiation.

Termination and Cancellation

Any order may be terminated by the Buyer only by written notice and upon payment of reasonable termination charges, including all costs plus profit.

Seller shall have the right to cancel any order at any time by written notice if Buyer breaches any of the terms hereof, becomes the subject of any proceeding under state or federal law for the relief of debtors, or otherwise becomes insolvent or bankrupt, generally does not pay its debts as they become due or makes an assignment for the benefit of creditors.

Appendix 1—Eaton Terms & Conditions

Effective Date: November 1, 2008

Prices

All prices are subject to change without notice. In the event of a price change, the effective date of the change will be the date of the new price or discount sheet, letter or telegram. All quotations made or orders accepted after the effective date will be on the new basis. For existing orders, the price of the unshipped portion of an order will be the price in effect at time of shipment.

Price Policy—Products and Services

When prices are quoted as firm for quoted shipment, they are firm provided the following conditions are met:

1. The order is released with complete engineering details.
2. Shipment of Products are made, and Services purchased are provided within the quoted lead time.
3. When drawings for approval are required for any Products, the drawings applicable to those Products must be returned within 30* calendar days from the date of the original mailing of the drawings by Seller. The return drawings must be released for manufacture and shipment and must be marked "APPROVED" or "APPROVED AS NOTED." Drawing re-submittals which are required for any other reason than to correct Seller errors will not extend the 30-day period.

* 60 days for orders through contractors to allow time for their review and approval before and after transmitting them to their customers.

If the Buyer initiates or in any way causes delays in shipment, provision of Services or return of approval drawings beyond the periods stated above, the price of the Products or Services will be increased 1% per month or fraction thereof up to a maximum of 18 months from the date of the Buyer's order. For delays resulting in shipment or provision of Services beyond 18 months from the date of the Buyer's order, the price must be renegotiated.

Price Policy—BLS

Refer to Price Policy 25-050.

Minimum Billing

Orders less than \$1,000 will be assessed a shipping and handling charge of 5% of the price of the order, with a minimum charge of \$25.00 unless noted differently on Product discount sheets.

Taxes

The price does not include any taxes. Buyer shall be responsible for the payment of all taxes applicable to, or arising from the transaction, the Products, its sale, value, or use, or any Services performed in connection therewith regardless of the person or entity actually taxed.

Terms of Payment

Products

Acceptance of all orders is subject to the Buyer meeting Seller's credit requirements. Terms of payment are subject to change for failure to meet such requirements. Seller reserves the right at any time to demand full or partial payment before proceeding with a contract of sale as a result of changes in the financial condition of the Buyer. Terms of Payment are either Net 30 days from the date of invoice of each shipment or carry a cash discount based on Product type. Specific payment terms for Products are outlined in the applicable Product discount schedules.

Services

Terms of payment are net within 30 days from date of invoice for orders amounting to less than \$50,000.00.

Terms of payment for orders exceeding \$50,000.00 shall be made according to the following:

1. Twenty percent (20%) of order value with the purchase order payable 30 days from date of invoice.
2. Eighty percent (80%) of order value in equal monthly payments over the performance period payable 30 days from date of invoice.

Except for work performed (i) under a firm fixed price basis or (ii) pursuant to terms of a previously priced existing contract between Seller and Buyer, invoices for work performed by Seller shall have added and noted on each invoice a charge of 3% (over and above the price of the work) which is related to Seller compliance with present and proposed environmental, health, and safety regulations associated with prescribed requirements covering hazardous materials management and employee training, communications, personal protective equipment, documentation and record keeping associated therewith.

Adequate Assurances

If, in the judgment of Seller, the financial condition of the Buyer, at any time during the period of the contract, does not justify the terms of payment specified, Seller may require full or partial payment in advance.

Delayed Payment

If payments are not made in accordance with these terms, a service charge will, without prejudice to the right of Seller to immediate payment, be added in an amount equal to the lower of 1.5% per month or fraction thereof or the highest legal rate on the unpaid balance.

Freight

Freight policy will be listed on the Product discount sheets, or at option of Seller one of the following freight terms will be quoted.

F.O.B.—P/S—Frt./Ppd. and Invoiced

Products are sold F.O.B. point of shipment freight prepaid and invoiced to the Buyer.

F.O.B.—P/S—Frt./Ppd. and Allowed

Products sold are delivered F.O.B. point of shipment, freight prepaid and included in the price.

F.O.B. Destination—Frt./Ppd. and Allowed

At Buyer's option, Seller will deliver the Products F.O.B. destination freight prepaid and 2% will be added to the net price.

The term "freight prepaid" means that freight charges will be prepaid to the accessible common carrier delivery point nearest the destination for shipments within the United States and Puerto Rico unless noted differently on the Product discount sheets. For any other destination contact Seller's representative.

Shipment and Routing

Seller shall select the point of origin of shipment, the method of transportation, the type of carrier equipment and the routing of the shipment.

If the Buyer specifies a special method of transportation, type of carrier equipment, routing, or delivery requirement, Buyer shall pay all special freight and handling charges.

When freight is included in the price, no allowance will be made in lieu of transportation if the Buyer accepts shipment at factory, warehouse, or freight station or otherwise supplies its own transportation.

Risk of Loss

Risk of loss or damage to the Products shall pass to Buyer at the F.O.B. point.

Concealed Damage

Except in the event of F.O.B. destination shipments, Seller will not participate in any settlement of claims for concealed damage.

When shipment has been made on an F.O.B. destination basis, the Buyer must unpack immediately and, if damage is discovered must:

1. Not move the Products from the point of examination.
2. Retain shipping container and packing material.
3. Notify the carrier in writing of any apparent damage.
4. Notify Seller representative within 72 hours of delivery.
5. Send Seller a copy of the carrier's inspection report.

Witness Tests/Customer Inspection

Standard factory tests may be witnessed by the Buyer at Seller's factory for an additional charge calculated at the rate of \$2,500 per day (not to exceed eight (8) hours) per Product type. Buyer may final inspect Products at the Seller's factory for \$500 per day per Product type.

Witness tests will add one (1) week to the scheduled shipping date. Seller will notify Buyer fourteen (14) calendar days prior to scheduled witness testing or inspection. In the event Buyer is unable to attend, the Parties shall mutually agree on a rescheduled date. However, Seller reserves the right to deem the witness tests waived with the right to ship and invoice Products.

Held Orders

For any order held, delayed or rescheduled at the request of the Buyer, Seller may, at its sole option (1) require payment to be based on any reasonable basis, including but not limited to the contract price, and any additional expenses, or cost resulting from such a delay; (2) store Products at the sole cost and risk of loss of the Buyer; and/ or (3) charge to the Buyer those prices under the applicable price policy. Payment for such price, expenses and costs, in any such event, shall be due by Buyer within thirty (30) days from date of Seller's invoice. Any order so held delayed or rescheduled beyond six (6) months will be treated as a Buyer termination.

Drawing Approval

Seller will design the Products in line with, in Seller's judgment, good commercial practice. If at drawing approval Buyer makes changes outside of the design as covered in their specifications, Seller will then be paid reasonable charges and allowed a commensurate delay in shipping date based on the changes made.

Drawing Re-Submittal

When Seller agrees to do so in its quotation, Seller shall provide Buyer with the first set of factory customer approval drawing(s) at Seller's expense. The customer approval drawing(s) will be delivered at the quoted delivery date. If Buyer requests drawing changes or additions after the initial factory customer approval drawing(s) have been submitted by Seller, the Seller, at its option, may assess Buyer drawing charges. Factory customer approval drawing changes required due to misinterpretation by Seller will be at Seller's expense. Approval drawings generated by Bid Manager are excluded from this provision.

Warranty**Warranty for Products**

Seller warrants that the Products manufactured by it will conform to Seller's applicable specifications and be free from failure due to defects in workmanship and material for one (1) year from the date of installation of the Product or eighteen (18) months from the date of shipment of the Product, whichever occurs first.

In the event any Product fails to comply with the foregoing warranty Seller will, at its option, either (a) repair or replace the defective Product, or defective part or component thereof, F.O.B. Seller's facility freight prepaid, or (b) credit Buyer for the purchase price of the Product. All warranty claims shall be made in writing.

Seller requires all non-conforming Products be returned at Seller's expense for evaluation unless specifically stated otherwise in writing by Seller.

This warranty does not cover failure or damage due to storage, installation, operation or maintenance not in conformance with Seller's recommendations and industry standard practice or due to accident, misuse, abuse or negligence. This warranty does not cover reimbursement for labor, gaining access, removal, installation, temporary power or any other expenses, which may be incurred in connection with repair or replacement.

This warranty does not apply to equipment not manufactured by Seller. Seller limits itself to extending the same warranty it receives from the supplier.

Appendix 1—Eaton Terms & Conditions

Effective Date: November 1, 2008

Extended Warranty for Products

If requested by the Buyer and specifically accepted in writing by Seller, the foregoing standard warranty for Products will be extended from the date of shipment for the period and price indicated below:

- 24 months—2% of Contract Price
- 30 months—3% of Contract Price
- 36 months—4% of Contract Price

Special Warranty (In and Out) for Products

If requested by the Buyer and specifically accepted in writing by Seller, Seller will, during the warranty period for Products, at an additional cost of 2% of the contract price, be responsible for the direct cost of:

1. Removing the Product from the installed location.
2. Transportation to the repair facility and return to the site.
3. Reinstallation on site.

The total liability of Seller for this Special Warranty for Products is limited to 50% of the contract price of the particular Product being repaired and excludes expenses for removing adjacent apparatus, walls, piping, structures, temporary service, etc.

Warranty for Services

Seller warrants that the Services performed by it hereunder will be performed in accordance with generally accepted professional standards.

The Services, which do not so conform, shall be corrected by Seller upon notification in writing by the Buyer within one (1) year after completion of the Services.

Unless otherwise agreed to in writing by Seller, Seller assumes no responsibility with respect to the suitability of the Buyer's, or its customer's, equipment or with respect to any latent defects in equipment not supplied by Seller. This warranty does not cover damage to Buyer's, or its customer's, equipment, components or parts resulting in whole or in part from improper maintenance or operation or from their deteriorated condition. Buyer will, at its cost, provide Seller with unobstructed access to the defective Services, as well as adequate free working space in the immediate vicinity of the defective Services and such facilities and systems, including, without limitation, docks, cranes and utility disconnects and connects, as may be necessary in order that Seller may perform its warranty obligations. The conducting of any tests shall be mutually agreed upon and Seller shall be notified of, and may be present at, all tests that may be made.

Warranty for Power Systems Studies

Seller warrants that any power systems studies performed by it will conform to generally accepted professional standards. Any portion of the study, which does not so conform, shall be corrected by Seller upon notification in writing by the Buyer within six (6) months after completion of the study. All warranty work shall be performed in a single shift straight time basis Monday through Friday. In the event that the study requires correction of warranty items on an overtime schedule, the premium portion of such overtime shall be for the Buyer's account.

Limitation on Warranties for Products, Services and Power Systems Studies

THE FOREGOING WARRANTIES ARE EXCLUSIVE EXCEPT FOR WARRANTY OF TITLE. SELLER DISCLAIMS ALL OTHER WARRANTIES INCLUDING ANY IMPLIED WARRANTIES OF MERCHANTABILITY AND FITNESS FOR A PARTICULAR PURPOSE.

CORRECTION OF NON-CONFORMITIES IN THE MANNER AND FOR THE PERIOD OF TIME PROVIDED ABOVE SHALL CONSTITUTE SELLER'S SOLE LIABILITY AND BUYER'S EXCLUSIVE REMEDY FOR FAILURE OF SELLER TO MEET ITS WARRANTY OBLIGATIONS, WHETHER CLAIMS OF THE BUYER ARE BASED IN CONTRACT, IN TORT (INCLUDING NEGLIGENCE OR STRICT LIABILITY), OR OTHERWISE.

Asbestos

Federal Law requires that building or facility owners identify the presence, location and quantity of asbestos containing material (hereinafter "ACM") at work sites. Seller is not licensed to abate ACM. Accordingly, for any contract which includes the provision of Services, prior to (i) commencement of work at any site under a specific Purchase Order, (ii) a change in the work scope of any Purchase Order, the Buyer will certify that the work area associated with the Seller's scope of work includes the handling of Class II ACM, including but not limited to generator wedges and high temperature gaskets which include asbestos materials. The Buyer shall, at its expense, conduct abatement should the removal, handling, modification or reinstallation, or some or all of them, of said Class II ACM be likely to generate airborne asbestos fibers; and should such abatement affect the cost of or time of performance of the work then Seller shall be entitled to an equitable adjustment in the schedule, price and other pertinent affected provisions of the contract.

Compliance with Nuclear Regulation

Seller's Products are sold as commercial grade Products not intended for application in facilities or activities licensed by the United States Nuclear Regulatory Commission for atomic purposes. Further certification will be required for use of the Products in any safety-related application in any nuclear facility licensed by the U.S. Nuclear Regulatory Commission.

Returning Products

Authorization and shipping instructions for the return of any Products must be obtained from Seller before returning the Products.

When return is occasioned due to Seller error, full credit including all transportation charges will be allowed.

Product Notices

Buyer shall provide the user (including its employees) of the Products with all Seller supplied Product notices, warnings, instructions, recommendations, and similar materials.

Force Majeure

Seller shall not be liable for failure to perform or delay in performance due to fire, flood, strike or other labor difficulty, act of God, act of any governmental authority or of the Buyer, riot, embargo, fuel or energy shortage, car shortage, wrecks or delays in transportation, or due to any other cause beyond Seller's reasonable control. In the event of delay in performance due to any such cause, the date of delivery or time for completion will be extended by a period of time reasonably necessary to overcome the effect of such delay.

Liquidated Damages

Contracts which include liquidated damage clauses for failure to meet shipping or job completion promises are not acceptable or binding on Seller, unless such clauses are specifically accepted in writing by an authorized representative of the Seller at its headquarters office.

Patent Infringement

Seller will defend or, at its option, settle any suit or proceeding brought against Buyer, or Buyer's customers, to the extent it is based upon a claim that any Product or part thereof, manufactured by Seller or its subsidiaries and furnished hereunder, infringes any United States patent, other than a claim of infringement based upon use of a Product or part thereof in a process, provided Seller is notified in reasonable time and given authority, information and assistance (at Seller's expense) for the defense of same. Seller shall pay all legal and court costs and expenses and court-assessed damages awarded therein against Buyer resulting from or incident to such suit or proceeding. In addition to the foregoing, if at any time Seller determines there is a substantial question of infringement of any United States patent, and the use of such Product is or may be enjoined, Seller may, at its option and expense: either (a) procure for Buyer the right to continue using and selling the Product; (b) replace the Product with non-infringing apparatus; (c) modify the Product so it becomes non-infringing; or (d) as a last resort, remove the Product and refund the purchase price, equitably adjusted for use and obsolescence. In no case does Seller agree to pay any recovery based upon its Buyer's savings or profit through use of Seller's Products whether the use be special or ordinary. The foregoing states the entire liability of Seller for patent infringement.

The preceding paragraph does not apply to any claim of infringement based upon: (a) any modification made to a Product other than by Seller; (b) any design and/or specifications of Buyer to which a Product was manufactured; or (c) the use or combination of Product with other products where the Product does not itself infringe. As to the above-identified claim situations where the preceding paragraph does not apply, Buyer shall defend and hold Seller harmless in the same manner and to the extent as Seller's obligations described in the preceding paragraph. Buyer shall be responsible for obtaining (at Buyer's expense) all license rights required for Seller to be able to use software products in the possession of Buyer where such use is required in order to perform any Service for Buyer.

With respect to a Product or part thereof not manufactured by Seller or its subsidiaries, Seller will attempt to obtain for Buyer, from the supplier(s), the patent indemnification protection normally provided by the supplier(s) to customers.

Compliance with OSHA

Seller offers no warranty and makes no representation that its Products comply with the provisions or standards of the Occupational Safety and Health Act of 1970, or any regulation issued thereunder. In no event shall Seller be liable for any loss, damage, fines, penalty or expenses arising under said Act.

Limitation of Liability

THE REMEDIES OF THE BUYER SET FORTH IN THIS CONTRACT ARE EXCLUSIVE AND ARE ITS SOLE REMEDIES FOR ANY FAILURE OF SELLER TO COMPLY WITH ITS OBLIGATIONS HEREUNDER.

NOTWITHSTANDING ANY PROVISION IN THIS CONTRACT TO THE CONTRARY, IN NO EVENT SHALL SELLER BE LIABLE IN CONTRACT, IN TORT (INCLUDING NEGLIGENCE OR STRICT LIABILITY) OR OTHERWISE FOR DAMAGE TO PROPERTY OR EQUIPMENT OTHER THAN PRODUCTS SOLD HEREUNDER, LOSS OF PROFITS OR REVENUE, LOSS OF USE OF PRODUCTS, COST OF

CAPITAL, CLAIMS OF CUSTOMERS OF THE BUYER OR ANY SPECIAL, INDIRECT, INCIDENTAL OR CONSEQUENTIAL DAMAGES WHATSOEVER, REGARDLESS OF WHETHER SUCH POTENTIAL DAMAGES ARE FORESEEABLE OR IF SELLER HAS BEEN ADVISED OF THE POSSIBILITY OF SUCH DAMAGES.

THE TOTAL CUMULATIVE LIABILITY OF SELLER ARISING FROM OR RELATED TO THIS CONTRACT WHETHER THE CLAIMS ARE BASED IN CONTRACT, IN TORT (INCLUDING NEGLIGENCE OR STRICT LIABILITY) OR OTHERWISE, SHALL NOT EXCEED THE PRICE OF THE PRODUCT OR SERVICES ON WHICH SUCH LIABILITY IS BASED.

Westinghouse 6 and 7 Digit Style Numbers

Westinghouse 6/7 Digit Style Number	Eaton Catalog Number	Eaton 10 Digit Style Number	Description	Type	Voltage Rating kV Max.	Current Rating Amperes
282429	25CLPT-.5E	677C452G04	CL fuse unit	CLE-PT	25	0.5
282430	8CLPT-.5E	677C452G02	CL fuse unit	CLE-PT	8.3	0.5
364228	Obsolete—contact Eaton	—	6 ft switch stick	—	—	—
364229	Obsolete—contact Eaton	—	10 ft switch stick	—	—	—
562477	Obsolete—contact Eaton	677C593G01	CL fuse unit	CLV	0.6	2
823252	15BA2-5E	117D123A18	Fuse refill unit	BA-200	15.5	5
825626	Obsolete—contact Eaton	304C437G01	Outdoor disconnect mounting	BA-200	8.3	200
825627	Obsolete—contact Eaton	304C437G02	Outdoor disconnect mounting	BA-200	15.5	200
825628	Obsolete—contact Eaton	—	Outdoor disconnect mounting	BA-200	25.5	200
825629	Obsolete—contact Eaton	423D769G05	Disconnect fuse holder	BA-200	8.3	200
825630	Obsolete—contact Eaton	423D769G06	Disconnect fuse holder	BA-200	15.5	200
825631	Obsolete—contact Eaton	423D769G07	Disconnect fuse holder	BA-200	25.5	200
825725	Obsolete—contact Eaton	—	Disconnect live parts	BA-200	—	200
834237	25BA2-200E	117D123A46	Fuse refill unit	BA-200	25.5	200
834238	8BA2-5E	117D123A02	Fuse refill unit	BA-200	8.3	5
834239	8BA2-10E	117D123A04	Fuse refill unit	BA-200	8.3	10
834240	8BA2-15E	117D123A05	Fuse refill unit	BA-200	8.3	15
834241	8BA2-20E	117D123A06	Fuse refill unit	BA-200	8.3	20
834242	8BA2-25E	117D123A07	Fuse refill unit	BA-200	8.3	25
834243	8BA2-30E	117D123A08	Fuse refill unit	BA-200	8.3	30
834244	8BA2-40E	117D123A09	Fuse refill unit	BA-200	8.3	40
834245	8BA2-50E	117D123A10	Fuse refill unit	BA-200	8.3	50
834246	8BA2-65E	117D123A11	Fuse refill unit	BA-200	8.3	65
834247	8BA2-80E	117D123A12	Fuse refill unit	BA-200	8.3	80
834248	8BA2-100E	117D123A13	Fuse refill unit	BA-200	8.3	100
834249	8BA2-125E	117D123A14	Fuse refill unit	BA-200	8.3	125
834250	8BA2-150E	117D123A15	Fuse refill unit	BA-200	8.3	150
834251	8BA2-200E	117D123A16	Fuse refill unit	BA-200	8.3	200
834252	15BA2-5E	117D123A18	Fuse refill unit	BA-201	15.5	5
834253	15BA2-10E	117D123A20	Fuse refill unit	BA-200	15.5	10
834254	15BA2-15E	117D123A21	Fuse refill unit	BA-200	15.5	15
834255	15BA2-20E	117D123A22	Fuse refill unit	BA-200	15.5	20
834256	15BA2-25E	117D123A23	Fuse refill unit	BA-200	15.5	25
834257	15BA2-30E	117D123A24	Fuse refill unit	BA-200	15.5	30
834258	15BA2-40E	117D123A25	Fuse refill unit	BA-200	15.5	40
834259	15BA2-50E	117D123A26	Fuse refill unit	BA-200	15.5	50
834260	15BA2-65E	117D123A27	Fuse refill unit	BA-200	15.5	65
834261	15BA2-80E	117D123A28	Fuse refill unit	BA-201	15.5	80
834262	15BA2-125E	117D123A29	Fuse refill unit	BA-202	15.5	100
834263	15BA2-125E	117D123A30	Fuse refill unit	BA-203	15.5	125
834264	15BA2-150E	117D123A31	Fuse refill unit	BA-204	15.5	150
834265	15BA2-200E	117D123A32	Fuse refill unit	BA-205	15.5	200
834266	25BA2-5E	117D123A34	Fuse refill unit	BA-201	25.5	5
834267	25BA2-10E	117D123A36	Fuse refill unit	BA-200	25.5	10
834268	25BA2-15E	117D123A37	Fuse refill unit	BA-200	25.5	15
834269	25BA2-20E	117D123A38	Fuse refill unit	BA-200	25.5	20
834270	25BA2-25E	117D123A39	Fuse refill unit	BA-200	25.5	25
834271	25BA2-30E	117D123A40	Fuse refill unit	BA-200	25.5	30
834272	25BA2-40E	117D123A41	Fuse refill unit	BA-200	25.5	40
834273	25BA2-50E	117D123A42	Fuse refill unit	BA-200	25.5	50

Appendix 2—Superseded Style Number Index

Westinghouse 6/7 Digit Style Number	Eaton Catalog Number	Eaton 10 Digit Style Number	Description	Type	Voltage Rating kV Max.	Current Rating Amperes
834274	25BA2-65E	117D123A43	Fuse refill unit	BA-200	25.5	65
834275	25BA2-80E	117D123A44	Fuse refill unit	BA-200	25.5	80
834276	25BA2-125E	117D123A45	Fuse refill unit	BA-200	25.5	100
834277	25BA2-125E	117D123A46	Fuse refill unit	BA-200	25.5	125
834278	25BA2-150E	117D123A47	Fuse refill unit	BA-200	25.5	150
841737	8BA2-.5E	117D123A01	Fuse refill unit	BA-200	8.3	0.5
841831	Obsolete—contact Eaton	—	Indoor non-disconnect mounting	BA-100	15.5	100
858999	15BA2-.5E	117D123A17	Fuse refill unit	BA-200	15.5	0.5
859000	25BA2-.5E	117D123A33	Fuse refill unit	BA-200	25.5	0.5
859003	Obsolete—contact Eaton	—	Indoor non-disconnect mounting	BA-100	8.3	100
859004	Obsolete—contact Eaton	—	Indoor non-disconnect mounting	BA-100	25.5	100
859198	Obsolete—contact Eaton	423D769G01	Disconnect fuse holder ECD	BA-200	8.3	200
859199	Obsolete—contact Eaton	423D769G02	Disconnect fuse holder ECD	BA-200	15.5	200
859200	Obsolete—contact Eaton	423D769G03	Disconnect fuse holder ECD	BA-200	25.5	200
895134	Obsolete—contact Eaton	423D769G04	Disconnect fuse holder ECD	BA-200	38	400
895307	Obsolete—contact Eaton	—	Disconnect fuse holder	BA-400	25.5	400
896681	Obsolete—contact Eaton	—	Disconnect fuse holder	BA-400	8.3	400
896682	Obsolete—contact Eaton	—	Disconnect fuse holder	BA-400	15.5	400
896727	Obsolete—contact Eaton	—	Disconnect fuse holder	BA-400	8.3	400
896728	Obsolete—contact Eaton	—	Disconnect fuse holder	BA-400	15.5	400
896729	Obsolete—contact Eaton	—	Disconnect fuse holder	BA-400	25.5	400
896730	Obsolete—contact Eaton	—	Disconnect fuse holder	BA-400	38	400
896735	Obsolete—contact Eaton	—	Disconnect live parts	BA-400		400
896793	8BA4-125E	116D977A14	Fuse refill unit	BA-400	8.3	125
896794	15BA4-125E	116D977A34	Fuse refill unit	BA-400	12.5	125
896795	25BA4-125E	116D977A54	Fuse refill unit	BA-400	25.5	125
896796	38BA4-125E	116D977A74	Fuse refill unit	BA-400	38	125
896804	8BA4-5E	116D977A02	Fuse refill unit	BA-400	8.3	5
896805	Obsolete—contact Eaton	—	Fuse refill unit	BA-400	8.3	8
896806	8BA4-10E	116D977A04	Fuse refill unit	BA-400	8.3	10
896807	8BA4-15E	116D977A05	Fuse refill unit	BA-400	8.3	15
896808	8BA4-20E	116D977A06	Fuse refill unit	BA-400	8.3	20
896809	8BA4-25E	116D977A07	Fuse refill unit	BA-400	8.3	25
896810	8BA4-30E	116D977A08	Fuse refill unit	BA-400	8.3	30
896811	8BA4-40E	116D977A09	Fuse refill unit	BA-400	8.3	40
896812	8BA4-50E	116D977A10	Fuse refill unit	BA-400	8.3	50
896813	8BA4-65E	116D977A11	Fuse refill unit	BA-400	8.3	62
896814	8BA4-80E	116D977A12	Fuse refill unit	BA-400	8.3	80
896815	8BA4-100E	116D977A13	Fuse refill unit	BA-400	8.3	100
896816	8BA4-150E	116D977A15	Fuse refill unit	BA-400	8.3	150
896817	8BA4-200E	116D977A16	Fuse refill unit	BA-400	8.3	200
896818	8BA4-250E	116D977A17	Fuse refill unit	BA-400	8.3	250
896819	8BA4-300E	116D977A18	Fuse refill unit	BA-400	8.3	300
896820	8BA4-400E	116D977A19	Fuse refill unit	BA-400	8.3	400
896821	15BA4-5E	116D977A22	Fuse refill unit	BA-400	15.5	5
896822	Obsolete—contact Eaton	—	Fuse refill unit	BA-400	15.5	8
896823	15BA4-10E	116D977A24	Fuse refill unit	BA-400	15.5	10
896824	15BA4-15E	116D977A25	Fuse refill unit	BA-400	15.5	15
896825	15BA4-20E	116D977A26	Fuse refill unit	BA-400	15.5	20
896826	15BA4-25E	116D977A27	Fuse refill unit	BA-400	15.5	25
896827	15BA4-30E	116D977A28	Fuse refill unit	BA-400	15.5	30
896828	15BA4-40E	116D977A29	Fuse refill unit	BA-400	15.5	40
896829	15BA4-50E	116D977A30	Fuse refill unit	BA-400	15.5	50

Appendix 2—Superseded Style Number Index

Westinghouse 6/7 Digit Style Number	Eaton Catalog Number	Eaton 10 Digit Style Number	Description	Type	Voltage Rating kV Max.	Current Rating Amperes
896830	15BA4-65E	116D977A31	Fuse refill unit	BA-400	15.5	62
896831	15BA4-80E	116D977A32	Fuse refill unit	BA-400	15.5	80
896832	15BA4-100E	116D977A33	Fuse refill unit	BA-400	15.5	100
896833	15BA4-150E	116D977A35	Fuse refill unit	BA-400	15.5	150
896834	15BA4-200E	116D977A36	Fuse refill unit	BA-400	15.5	200
896835	15BA4-250E	116D977A37	Fuse refill unit	BA-400	15.5	250
896836	15BA4-300E	116D977A38	Fuse refill unit	BA-400	15.5	300
896837	15BA4-400E	116D977A39	Fuse refill unit	BA-400	15.5	400
896838	25BA4-5E	116D977A42	Fuse refill unit	BA-400	25.5	5
896839	Obsolete—contact Eaton	—	Fuse refill unit	BA-400	25.5	8
896840	25BA4-10E	116D977A44	Fuse refill unit	BA-400	25.5	10
896841	25BA4-15E	116D977A45	Fuse refill unit	BA-400	25.5	15
896842	25BA4-20E	116D977A46	Fuse refill unit	BA-400	25.5	20
896843	25BA4-25E	116D977A47	Fuse refill unit	BA-400	25.5	25
896844	25BA4-30E	116D977A48	Fuse refill unit	BA-400	25.5	30
896845	25BA4-40E	116D977A49	Fuse refill unit	BA-400	25.5	40
896846	25BA4-50E	116D977A50	Fuse refill unit	BA-400	25.5	50
896847	25BA4-65E	116D977A51	Fuse refill unit	BA-400	25.5	62
896848	25BA4-80E	116D977A52	Fuse refill unit	BA-400	25.5	80
896849	25BA4-100E	116D977A53	Fuse refill unit	BA-400	25.5	100
896850	25BA4-150E	116D977A55	Fuse refill unit	BA-400	25.5	150
896851	25BA4-200E	116D977A56	Fuse refill unit	BA-400	25.5	200
896852	25BA4-250E	116D977A57	Fuse refill unit	BA-400	25.5	250
896853	25BA4-300E	116D977A58	Fuse refill unit	BA-400	25.5	300
896854	Obsolete—contact Eaton	—	Fuse refill unit	BA-400	25.5	400
896855	38BA4-5E	116D977A62	Fuse refill unit	BA-400	38	5
896856	Obsolete—contact Eaton	—	Fuse refill unit	BA-400	38	8
896857	38BA4-10E	116D977A64	Fuse refill unit	BA-400	38	10
896858	38BA4-15E	116D977A65	Fuse refill unit	BA-400	38	15
896859	38BA4-20E	116D977A66	Fuse refill unit	BA-400	38	20
896860	38BA4-25E	116D977A67	Fuse refill unit	BA-400	38	25
896861	38BA4-30E	116D977A68	Fuse refill unit	BA-400	38	30
896862	38BA4-40E	116D977A69	Fuse refill unit	BA-400	38	40
896863	38BA4-50E	116D977A70	Fuse refill unit	BA-400	38	50
896864	38BA4-65E	116D977A71	Fuse refill unit	BA-400	38	62
896865	38BA4-80E	116D977A72	Fuse refill unit	BA-400	38	80
896866	38BA4-100E	116D977A73	Fuse refill unit	BA-400	38	100
896867	38BA4-150E	116D977A75	Fuse refill unit	BA-400	38	150
896868	38BA4-200E	116D977A76	Fuse refill unit	BA-400	38	200
896869	38BA4-250E	116D977A77	Fuse refill unit	BA-400	38	250
896870	38BA4-300E	116D977A78	Fuse refill unit	BA-400	38	300
896871	Obsolete—contact Eaton	—	Fuse refill unit	BA-400	38	400
918534	8BA2-5E	117D123A02	Fuse refill unit	BA-200	8.3	5
918535	Obsolete—contact Eaton	—	Fuse refill unit	BA-200	15.5	8
918536	Obsolete—contact Eaton	—	Fuse refill unit	BA-200	25.5	8
918537	8BA2-200E	117D123A16	Fuse refill unit	BA-200	8.3	200
918538	15RBA2-150E	117D123A31	Fuse refill unit	BA-200	15.5	150
918539	25RBA2-150E	117D123A47	Fuse refill unit	BA-200	25.5	150
938936	25RBA4-.5E	116D977A41	Fuse refill unit	BA-400	25.5	0.5
938937	38RBA4-.5E	116D977A61	Fuse refill unit	BA-400	38	0.5
940001	Obsolete—contact Eaton	—	Indoor disconnect mounting	BA-400	8.3	400
940002	Obsolete—contact Eaton	—	Indoor disconnect mounting	BA-400	15.5	400
940003	Obsolete—contact Eaton	—	Indoor disconnect mounting	BA-400	25.5	400

Appendix 2—Superseded Style Number Index

Westinghouse 6/7 Digit Style Number	Eaton Catalog Number	Eaton 10 Digit Style Number	Description	Type	Voltage Rating kV Max.	Current Rating Amperes
940004	Obsolete—contact Eaton	—	Indoor disconnect mounting	BA-200	8.3	200
940005	Obsolete—contact Eaton	—	Indoor disconnect mounting	BA-200	15.5	200
940006	Obsolete—contact Eaton	—	Indoor disconnect mounting	BA-200	25.5	200
940007	Obsolete—contact Eaton	—	Indoor non-disconnect fuse holder	BA-100	8.3	100
940008	Obsolete—contact Eaton	—	Indoor non-disconnect fuse holder	BA-100	15.5	100
940009	Obsolete—contact Eaton	—	Indoor non-disconnect fuse holder	BA-100	25.5	100
948932	Obsolete—contact Eaton	—	Indoor disconnect mounting	BA-400	38	400
948933	Obsolete—contact Eaton	—	Indoor non-disconnect live parts	BA-100		100
948934	8RBA4-.5E	116D977A01	Fuse refill unit	BA-400	8.3	0.5
948935	15RBA4-.5E	116D977A21	Fuse refill unit	BA-400	15.5	0.5
970699	Obsolete—contact Eaton	434D316A04	Time lag fuse refill unit	BA-200	8.3	15
970700	Obsolete—contact Eaton	434D316A04	Time lag fuse refill unit	BA-200	8.3	15
970701	Obsolete—contact Eaton	434D316A05	Time lag fuse refill unit	BA-200	8.3	20
970702	Obsolete—contact Eaton	434D316A06	Time lag fuse refill unit	BA-200	8.3	25
970703	Obsolete—contact Eaton	434D316A07	Time lag fuse refill unit	BA-200	8.3	30
970704	Obsolete—contact Eaton	434D316A08	Time lag fuse refill unit	BA-200	8.3	40
970705	Obsolete—contact Eaton	434D316A09	Time lag fuse refill unit	BA-200	8.3	50
970706	Obsolete—contact Eaton	434D316A10	Time lag fuse refill unit	BA-200	8.3	65
970707	Obsolete—contact Eaton	434D316A11	Time lag fuse refill unit	BA-200	8.3	80
970708	Obsolete—contact Eaton	434D316A12	Time lag fuse refill unit	BA-200	8.3	100
970713	Obsolete—contact Eaton	434D316A19	Time lag fuse refill unit	BA-200	15.5	15
970714	Obsolete—contact Eaton	434D316A19	Time lag fuse refill unit	BA-200	15.5	15
970715	Obsolete—contact Eaton	434D316A20	Time lag fuse refill unit	BA-200	15.5	20
970716	Obsolete—contact Eaton	434D316A21	Time lag fuse refill unit	BA-200	15.5	25
970717	Obsolete—contact Eaton	434D316A22	Time lag fuse refill unit	BA-200	15.5	30
970718	Obsolete—contact Eaton	434D316A23	Time lag fuse refill unit	BA-200	15.5	40
970719	Obsolete—contact Eaton	434D316A24	Time lag fuse refill unit	BA-200	15.5	50
970720	Obsolete—contact Eaton	434D316A25	Time lag fuse refill unit	BA-200	15.5	65
970721	Obsolete—contact Eaton	434D316A26	Time lag fuse refill unit	BA-200	15.5	80
970722	Obsolete—contact Eaton	434D316A27	Time lag fuse refill unit	BA-200	15.5	100
970727	Obsolete—contact Eaton	434D316A34	Time lag fuse refill unit	BA-200	25.5	15
970728	Obsolete—contact Eaton	434D316A34	Time lag fuse refill unit	BA-200	25.5	15
970729	Obsolete—contact Eaton	434D316A35	Time lag fuse refill unit	BA-200	25.5	20
970730	Obsolete—contact Eaton	434D316A36	Time lag fuse refill unit	BA-200	25.5	25
970731	Obsolete—contact Eaton	434D316A37	Time lag fuse refill unit	BA-200	25.5	30
970732	Obsolete—contact Eaton	434D316A38	Time lag fuse refill unit	BA-200	25.5	40
970733	Obsolete—contact Eaton	434D316A39	Time lag fuse refill unit	BA-200	25.5	50
970734	Obsolete—contact Eaton	434D316A40	Time lag fuse refill unit	BA-200	25.5	65
970735	Obsolete—contact Eaton	434D316A41	Time lag fuse refill unit	BA-200	25.5	80
970736	Obsolete—contact Eaton	434D316A42	Time lag fuse refill unit	BA-200	25.5	100
1014184	Obsolete—contact Eaton	434D316A36	Time lag fuse refill unit	BA-200	25.5	25
1014190	Obsolete—contact Eaton	434D316A28	Time lag fuse refill unit	BA-200	15.5	125
1014191	Obsolete—contact Eaton	434D316A43	Time lag fuse refill unit	BA-200	25.5	125
1014286	RBA4-COND	310C197G04	Condenser (3 pack)	BA-400/RBA400	—	—
1043291	Obsolete—contact Eaton	423D769G08	Outdoor fuse holder 75	BA-200	38	200
1043297	38BA2-5E	117D123A50	Fuse refill unit	BA-200	38	5
1043298	38BA2-5E	117D123A50	Fuse refill unit	BA-200	38	5
1043299	38BA2-7E	117D123A51	Fuse refill unit	BA-200	38	7
1043300	38BA2-10E	117D123A52	Fuse refill unit	BA-200	38	10
1043301	38BA2-15E	117D123A53	Fuse refill unit	BA-200	38	15
1043302	38BA2-15E	117D123A53	Fuse refill unit	BA-200	38	15
1043303	38BA2-20E	117D123A54	Fuse refill unit	BA-200	38	20
1043304	38BA2-25E	117D123A55	Fuse refill unit	BA-200	38	25

Appendix 2—Superseded Style Number Index

Westinghouse 6/7 Digit Style Number	Eaton Catalog Number	Eaton 10 Digit Style Number	Description	Type	Voltage Rating kV Max.	Current Rating Amperes
1043305	38BA2-30E	117D123A56	Fuse refill unit	BA-200	38	30
1043306	38BA2-40E	117D123A57	Fuse refill unit	BA-200	38	40
1043307	38BA2-50E	117D123A58	Fuse refill unit	BA-200	38	50
1043308	38BA2-65E	117D123A59	Fuse refill unit	BA-200	38	65
1043309	38BA2-80E	117D123A60	Fuse refill unit	BA-200	38	80
1043310	38BA2-100E	117D123A61	Fuse refill unit	BA-200	38	100
1043311	38BA2-125E	117D123A62	Fuse refill unit	BA-200	38	125
1043312	38BA2-150E	117D123A63	Fuse refill unit	BA-200	38	150
1043331	38BA2-.5E	117D123A49	Fuse refill unit	BA-200	38	0.5
1043673	Obsolete—contact Eaton	—	Outdoor fuse holder ECD 50	BA-200	25.5	200
1043678	Obsolete—contact Eaton	434D316A49	Time lag fuse refill unit	BA-200	38	15
1043679	Obsolete—contact Eaton	434D316A49	Time lag fuse refill unit	BA-200	38	15
1043680	Obsolete—contact Eaton	434D316A50	Time lag fuse refill unit	BA-200	38	20
1043681	Obsolete—contact Eaton	434D316A51	Time lag fuse refill unit	BA-200	38	25
1043682	Obsolete—contact Eaton	434D316A52	Time lag fuse refill unit	BA-200	38	30
1043683	Obsolete—contact Eaton	434D316A53	Time lag fuse refill unit	BA-200	38	40
1043684	Obsolete—contact Eaton	434D316A54	Time lag fuse refill unit	BA-200	38	50
1043685	Obsolete—contact Eaton	434D316A55	Time lag fuse refill unit	BA-200	38	65
1043686	Obsolete—contact Eaton	434D316A56	Time lag fuse refill unit	BA-200	38	80
1043687	Obsolete—contact Eaton	434D316A57	Time lag fuse refill unit	BA-200	38	100
1043688	Obsolete—contact Eaton	434D316A58	Time lag fuse refill unit	BA-200	38	125
1043691	Obsolete—contact Eaton	423D769G04	Outdoor fuse holder ECD 50	BA-400	38	400
1043720	8BA4-300E	116D977A18	Fuse refill unit	BA-400	8.3	300
1081323	2NCLPT-.5E	677C592G02	CL fuse unit	NCLE-PT	2.75	0.5
1105207	Obsolete—contact Eaton	423D769G12	Outdoor fuse holder ECD 180	BA-400	38	200
1105208	Obsolete—contact Eaton	505D616A01	Live parts	BA-200	—	—
1105209	Obsolete—contact Eaton	505D615A01	Live parts	BA-400	—	—
1123938	Obsolete—contact Eaton	423D770G08	Outdoor fuse holder	BA-400	38	300
1196126	8CLPT-.5E	677C452G02	CL fuse unit	CLE-PT	8.3	0.5
1196127	15CLPT-.5E	677C452G03	CL fuse unit	CLE-PT	15.5	0.5
1196127D	2NCLPT-1E	677C592G03	CL fuse unit	NCLE-PT	2.75	1
1169143	2NCLPT-.5E	677C592G02	CL fuse unit	NCLE-PT	2.75	0.5
1247212	2NCLPT-1E	677C592G03	CL fuse unit	NCLE-PT	2.75	1
1247217	5CLPT-.5E	677C452G01	CL fuse unit	CLE-PT	5.5	0.5
1247218	8CLPT-.5E	677C452G02	CL fuse unit	CLE-PT	8.3	0.5
1247219	15CLPT-.5E	677C452G03	CL fuse unit	CLE-PT	15.5	0.5
1247220	25CLPT-.5E	677C452G04	CL fuse unit	CLE-PT	25.5	0.5
1251000	8DBA1-0.5	5980C15G01	—	—	—	—
1251000	8DBA1-3E	505D420G01	—	—	—	—
1251002	8DBA1-5E	5980C15G03	—	—	—	—
1251003	8DBA1-7E	5980C15G04	—	—	—	—
1251004	8DBA1-10E	5980C15G05	—	—	—	—
1251005	8DBA1-15E	5980C15G06	—	—	—	—
1251006	8DBA1-20E	5980C15G07	—	—	—	—
1251007	8DBA1-25E	5980C15G08	—	—	—	—
1251008	8DBA1-30E	5980C15G09	—	—	—	—
1251009	8DBA1-40E	5980C15G10	—	—	—	—
1251010	8DBA1-50E	5980C15G11	—	—	—	—
1251011	8DBA1-65E	5980C15G12	—	—	—	—
1251012	8DBA1-80E	5980C15G13	—	—	—	—
1251013	8DBA1-100E	5980C15G14	—	—	—	—
1251014	8DBA1-125E	5980C15G15	—	—	—	—
1251015	8DBA1-150E	5980C15G16	—	—	—	—

Appendix 2—Superseded Style Number Index

Westinghouse 6/7 Digit Style Number	Eaton Catalog Number	Eaton 10 Digit Style Number	Description	Type	Voltage Rating kV Max.	Current Rating Amperes
1251016	8DBA1-200E	5980C15G17	—	—	—	—
1251017	15DBA1-0.5	5980C15G21	—	—	—	—
1251018	15DBA1-3E	505D420G02	—	—	—	—
1251019	15DBA1-5E	5980C15G23	—	—	—	—
1251020	15DBA1-7E	5980C15G24	—	—	—	—
1251021	15DBA1-10E	5980C15G25	—	—	—	—
1251022	15DBA1-15E	5980C15G26	—	—	—	—
1251023	15DBA1-20E	5980C15G27	—	—	—	—
1251024	15DBA1-25E	5980C15G28	—	—	—	—
1251025	15DBA1-30E	5980C15G29	—	—	—	—
1251026	15DBA1-40E	5980C15G30	—	—	—	—
1251027	15DBA1-50E	5980C15G31	—	—	—	—
1251028	15DBA1-65E	5980C15G32	—	—	—	—
1251029	15DBA1-80E	5980C15G33	—	—	—	—
1251030	15DBA1-100E	5980C15G34	—	—	—	—
1251031	15DBA1-125E	5980C15G35	—	—	—	—
1251032	15DBA1-150E	5980C15G36	—	—	—	—
1251033	15DBA1-200E	5980C15G37	—	—	—	—
1251034	25DBA1-0.5	5980C16G01	—	—	—	—
1251035	25DBA1-3E	505D420G03	—	—	—	—
1251036	25DBA1-5E	5980C16G03	—	—	—	—
1251037	25DBA1-7E	5980C16G04	—	—	—	—
1251038	25DBA1-10E	5980C16G05	—	—	—	—
1251039	25DBA1-15E	5980C16G06	—	—	—	—
1251040	25DBA1-20E	5980C16G07	—	—	—	—
1251041	25DBA1-25E	5980C16G08	—	—	—	—
1251042	25DBA1-30E	5980C16G09	—	—	—	—
1251043	25DBA1-40E	5980C16G10	—	—	—	—
1251044	25DBA1-50E	5980C16G11	—	—	—	—
1251045	25DBA1-65E	5980C16G12	—	—	—	—
1251046	25DBA1-80E	5980C16G13	—	—	—	—
1251047	25DBA1-100E	5980C16G14	—	—	—	—
1251048	25DBA1-125E	5980C16G15	—	—	—	—
1251049	25DBA1-150E	5980C16G16	—	—	—	—
1251050	25DBA1-200E	5980C16G17	—	—	—	—
1251051	38DBA1-0.5	5980C16G21	—	—	—	—
1251052	38DBA1-3E	505D420G04	—	—	—	—
1251053	38DBA1-5E	5980C16G23	—	—	—	—
1251054	38DBA1-7E	5980C16G24	—	—	—	—
1251055	38DBA1-10E	5980C16G25	—	—	—	—
1251056	38DBA1-15E	5980C16G26	—	—	—	—
1251057	38DBA1-20E	5980C16G27	—	—	—	—
1251058	38DBA1-25E	5980C16G28	—	—	—	—
1251059	38DBA1-30E	5980C16G29	—	—	—	—
1251060	38DBA1-40E	5980C16G30	—	—	—	—
1251061	38DBA1-50E	5980C16G31	—	—	—	—
1251062	38DBA1-65E	5980C16G32	—	—	—	—
1251063	38DBA1-80E	5980C16G33	—	—	—	—
1251064	38DBA1-100E	5980C16G34	—	—	—	—
1251065	38DBA1-125E	5980C16G35	—	—	—	—
1251066	38DBA1-150E	5980C16G36	—	—	—	—
1251067	38DBA1-200E	5980C16G37	—	—	—	—
1251068	48DBA1-0.5	5980C17G01	—	—	—	—

Appendix 2—Superseded Style Number Index

Westinghouse 6/7 Digit Style Number	Eaton Catalog Number	Eaton 10 Digit Style Number	Description	Type	Voltage Rating kV Max.	Current Rating Amperes
1251069	48DBA1-3E	505D420G05	—	—	—	—
1251070	48DBA1-5E	5980C17G03	—	—	—	—
1251071	48DBA1-7E	5980C17G04	—	—	—	—
1251072	48DBA1-10E	5980C17G05	—	—	—	—
1251073	48DBA1-15E	5980C17G06	—	—	—	—
1251074	48DBA1-20E	5980C17G07	—	—	—	—
1251075	48DBA1-25E	5980C17G08	—	—	—	—
1251076	48DBA1-30E	5980C17G09	—	—	—	—
1251077	48DBA1-40E	5980C17G10	—	—	—	—
1251078	48DBA1-50E	5980C17G11	—	—	—	—
1251079	48DBA1-65E	5980C17G12	—	—	—	—
1251080	48DBA1-80E	5980C17G13	—	—	—	—
1251081	48DBA1-100E	5980C17G14	—	—	—	—
1251082	48DBA1-125E	5980C17G15	—	—	—	—
1251083	48DBA1-150E	5980C17G16	—	—	—	—
1251084	48DBA1-200E	5980C17G17	—	—	—	—
1251085	72DBA1-0.5	5980C17G21	—	—	—	—
1251086	72DBA1-3E	505D420G06	—	—	—	—
1251087	72DBA1-5E	5980C17G23	—	—	—	—
1251088	72DBA1-7E	5980C17G24	—	—	—	—
1251089	72DBA1-10E	5980C17G25	—	—	—	—
1251090	72DBA1-15E	5980C17G26	—	—	—	—
1251091	72DBA1-20E	5980C17G27	—	—	—	—
1251092	72DBA1-25E	5980C17G28	—	—	—	—
1251093	72DBA1-30E	5980C17G29	—	—	—	—
1251094	72DBA1-40E	5980C17G30	—	—	—	—
1251095	72DBA1-50E	5980C17G31	—	—	—	—
1251096	72DBA1-65E	5980C17G32	—	—	—	—
1251097	72DBA1-80E	5980C17G33	—	—	—	—
1251098	72DBA1-100E	5980C17G34	—	—	—	—
1251099	72DBA1-125E	5980C17G35	—	—	—	—
1251100	72DBA1-150E	5980C17G36	—	—	—	—
1251101	72DBA1-200E	5980C17G37	—	—	—	—
1251138	2NCLPT-1E	677C592G03	CL fuse unit	NCLE-PT	2.75	1
1254953	Obsolete—contact Eaton	677C593G01	CL fuse unit	CLV	0.6	2
1253955	Obsolete—contact Eaton	677C593G02	CL fuse unit	CLV	0.6	5
1257527	Obsolete—contact Eaton	—	Live parts	DBA-2	—	—
1257601	72DBA2-3E	11A8127G02	—	—	—	—
1257603	72DBA2-7E	11A8127G03	—	—	—	—
1257604	72DBA2-10E	11A8127G04	—	—	—	—
1257605	72DBA2-15E	11A8127G05	—	—	—	—
1257606	72DBA2-20E	11A8127G06	—	—	—	—
1257607	72DBA2-25E	11A8127G07	—	—	—	—
1257608	72DBA2-30E	11A8127G08	—	—	—	—
1257609	72DBA2-40E	11A8127G09	—	—	—	—
1257610	72DBA2-50E	11A8127G10	—	—	—	—
1257611	72DBA2-65E	11A8127G11	—	—	—	—
1257612	72DBA2-80E	11A8127G12	—	—	—	—
1257613	72DBA2-100E	11A8127G13	—	—	—	—
1257614	72DBA2-125E	11A8127G14	—	—	—	—
1257615	72DBA2-150E	11A8127G15	—	—	—	—
1257617	92DBA2-3E	11A8127G21	—	—	—	—
1257618	92DBA2-5E	11A8127G22	—	—	—	—

Appendix 2—Superseded Style Number Index

Westinghouse 6/7 Digit Style Number	Eaton Catalog Number	Eaton 10 Digit Style Number	Description	Type	Voltage Rating kV Max.	Current Rating Amperes
1257619	92DBA2-7E	11A8127G23	—	—	—	—
1257620	92DBA2-10E	11A8127G24	—	—	—	—
1257621	92DBA2-15E	11A8127G25	—	—	—	—
1257622	92DBA2-20E	11A8127G26	—	—	—	—
1257623	92DBA2-25E	11A8127G27	—	—	—	—
1257624	92DBA2-30E	11A8127G28	—	—	—	—
1257625	92DBA2-40E	11A8127G29	—	—	—	—
1257626	92DBA2-50E	11A8127G30	—	—	—	—
1257627	92DBA2-65E	11A8127G31	—	—	—	—
1257628	92DBA2-80E	11A8127G32	—	—	—	—
1257629	92DBA2-100E	11A8127G33	—	—	—	—
1257630	92DBA2-125E	11A8127G34	—	—	—	—
1257631	92DBA2-150E	11A8127G35	—	—	—	—
1257633	121DBA2-3E	11A8127G41	—	—	—	—
1257634	121DBA2-5E	11A8127G42	—	—	—	—
1257635	121DBA2-7E	11A8127G43	—	—	—	—
1257636	121DBA2-10E	11A8127G44	—	—	—	—
1257637	121DBA2-15E	11A8127G45	—	—	—	—
1257638	121DBA2-20E	11A8127G46	—	—	—	—
1257639	121DBA2-25E	11A8127G47	—	—	—	—
1257640	121DBA2-30E	11A8127G48	—	—	—	—
1257641	121DBA2-40E	11A8127G49	—	—	—	—
1257642	121DBA2-50E	11A8127G50	—	—	—	—
1257641	121DBA2-65E	11A8127G51	—	—	—	—
1257642	121DBA2-80E	11A8127G52	—	—	—	—
1257643	121DBA2-100E	11A8127G53	—	—	—	—
1257644	121DBA2-125E	11A8127G54	—	—	—	—
1257645	121DBA2-150E	11A8127G55	—	—	—	—
1285491	5CLPT-1E	677C452G06	CL fuse unit	CLE-PT	5.5	1
1291963	5CLPT-5E	677C453G01	CL fuse unit	CLE-PT	5.5	5
1291964	8CLPT-5E	677C453G02	CL fuse unit	CLE-PT	8.3	5
1291965	15CLPT-5E	677C453G03	CL fuse unit	CLE-PT	15.5	5
1291968	5CLPT-10E	677C453G04	CL fuse unit	CLE-PT	5.5	10
1291969	8CLPT-10E	677C453G05	CL fuse unit	CLE-PT	8.3	10
1291970	15CLPT-10E	677C453G06	CL fuse unit	CLE-PT	15.5	10
1301110	RBA2-COND	310C197G03	Condenser (3 pack)	BA-200/RBA-200	—	—
1305001	Obsolete—contact Eaton	—	Non-disconnect mounting	BA-100	5.5	100
1305002	Obsolete—contact Eaton	—	Non-disconnect mounting	BA-100	8.3	100
1305003	Obsolete—contact Eaton	—	Non-disconnect mounting	BA-100	14.4	100
1305004	Obsolete—contact Eaton	—	Non-disconnect mounting	BA-100	15.5	100
1305005	Obsolete—contact Eaton	—	Non-disconnect mounting	BA-100	25.5	100
1305006	Obsolete—contact Eaton	—	Non-disconnect mounting	BA-200	38	200
1305020	Obsolete—contact Eaton	414D224G01	Disconnect mounting	BA-200	5.5	200
1305021	Obsolete—contact Eaton	414D224G02	Disconnect mounting	BA-200	8.3	200
1305022	Obsolete—contact Eaton	414D224G03	Disconnect mounting	BA-100	14.4	100
1305023	Obsolete—contact Eaton	414D224G04	Disconnect mounting	BA-100	15.5	100
1305024	Obsolete—contact Eaton	414D224G05	Disconnect mounting	BA-200	25.5	—
1305025	Obsolete—contact Eaton	414D224G07	Mounting	BA-200	5.5	—
1305026	Obsolete—contact Eaton	414D224G08	Mounting	BA-200	8.3	—
1305027	Obsolete—contact Eaton	414D224G09	Mounting	BA-200	14.5	—
1305028	Obsolete—contact Eaton	414D224G10	Mounting	BA-200	15.5	—
1305030	Obsolete—contact Eaton	414D224G11	Mounting	BA-200	5.5	—
1305031	Obsolete—contact Eaton	414D224G12	Mounting	BA-200	8.3	—

Appendix 2—Superseded Style Number Index

Westinghouse 6/7 Digit Style Number	Eaton Catalog Number	Eaton 10 Digit Style Number	Description	Type	Voltage Rating kV Max.	Current Rating Amperes
1305032	Obsolete—contact Eaton	414D224G13	Mounting	BA-200	14.5	—
1305033	Obsolete—contact Eaton	414D224G14	Mounting	BA-200	15.5	—
1305035	Obsolete—contact Eaton	414D224G15	Disconnect mounting RC	BA-200	5.5	—
1305036	Obsolete—contact Eaton	414D224G16	Disconnect mounting RC	BA-200	8.3	—
1305037	Obsolete—contact Eaton	414D224G17	Disconnect mounting RC	BA-200	14.5	—
1305038	Obsolete—contact Eaton	414D224G18	Disconnect mounting RC	BA-200	15.5	—
1305040	Obsolete—contact Eaton	414D226G01	Disconnect mounting	BA-400	5.5	—
1305041	Obsolete—contact Eaton	414D226G02	Disconnect mounting	BA-400	8.3	—
1305042	Obsolete—contact Eaton	414D226G03	Disconnect mounting	BA-400	14.5	—
1305043	Obsolete—contact Eaton	414D226G04	Disconnect mounting	BA-400	15.5	—
1305044	Obsolete—contact Eaton	414D226G05	Disconnect mounting	BA-400	25.5	—
1305045	Obsolete—contact Eaton	414D226G07	Mounting	BA-400	5.5	—
1305046	Obsolete—contact Eaton	414D226G08	Mounting	BA-400	8.3	—
1305047	Obsolete—contact Eaton	414D226G09	Mounting	BA-400	14.5	—
1305048	Obsolete—contact Eaton	414D226G10	Mounting	BA-400	15.5	—
1305049	Obsolete—contact Eaton	414D226G11	Mounting	BA-400	15.5	—
1305050	Obsolete—contact Eaton	414D226G12	Mounting	BA-400	5.5	—
1305051	Obsolete—contact Eaton	414D226G13	Mounting	BA-400	8.3	—
1305052	Obsolete—contact Eaton	414D226G14	Mounting	BA-400	14.5	—
1305053	Obsolete—contact Eaton	414D226G15	Mounting	BA-400	15.5	—
1305054	Obsolete—contact Eaton	414D226G16	Mounting	BA-400	25.5	—
1305055	Obsolete—contact Eaton	414D226G17	Disconnect mounting RC	BA-400	5.5	—
1305056	Obsolete—contact Eaton	414D226G18	Disconnect mounting RC	BA-400	8.3	—
1305057	Obsolete—contact Eaton	414D226G19	Disconnect mounting RC	BA-400	14.5	—
1305058	Obsolete—contact Eaton	414D226G20	Disconnect mounting RC	BA-400	15.5	—
1305059	Obsolete—contact Eaton	414D226G21	Mounting	BA-400	25.5	—
1305060	Obsolete—contact Eaton	414D225G01	Disconnect mounting FCV	BA-200	5.5	—
1305061	Obsolete—contact Eaton	414D225G02	Disconnect mounting FCV	BA-200	8.3	—
1305062	Obsolete—contact Eaton	414D225G03	Disconnect mounting FCV	BA-200	14.5	—
1305063	Obsolete—contact Eaton	414D225G04	Disconnect mounting FCV	BA-200	15.5	—
1305064	Obsolete—contact Eaton	414D225G05	Disconnect mounting FCV	BA-200	25.5	—
1305065	Obsolete—contact Eaton	414D225G07	Mounting	BA-200	5.5	—
1305066	Obsolete—contact Eaton	414D225G08	Mounting	BA-200	8.3	—
1305067	Obsolete—contact Eaton	414D225G09	Mounting	BA-200	14.5	—
1305068	Obsolete—contact Eaton	414D225G10	Mounting	BA-200	15.5	—
1305070	Obsolete—contact Eaton	414D225G11	Mounting	BA-200	5.5	—
1305071	Obsolete—contact Eaton	414D225G12	Mounting	BA-200	8.3	—
1305072	Obsolete—contact Eaton	414D225G13	Mounting	BA-200	14.5	—
1305073	Obsolete—contact Eaton	414D225G14	Mounting	BA-200	15.5	—
1305075	Obsolete—contact Eaton	414D225G15	Disconnect mounting RCV	BA-200	5.5	—
1305076	Obsolete—contact Eaton	414D225G16	Disconnect mounting RCV	BA-200	8.3	—
1305077	Obsolete—contact Eaton	414D225G17	Disconnect mounting RCV	BA-200	14.5	—
1305078	Obsolete—contact Eaton	414D225G18	Disconnect mounting RCV	BA-200	15.5	—
1305080	Obsolete—contact Eaton	414D227G01	Disconnect mounting FCV	BA-400	5.5	—
1305081	Obsolete—contact Eaton	414D227G02	Disconnect mounting FCV	BA-400	8.3	—
1305082	Obsolete—contact Eaton	414D227G03	Disconnect mounting FCV	BA-400	14.5	—
1305083	Obsolete—contact Eaton	414D227G04	Disconnect mounting FCV	BA-400	15.5	—
1305084	Obsolete—contact Eaton	414D227G05	Disconnect mounting FCV	BA-400	25.5	—
1305085	Obsolete—contact Eaton	414D227G07	Mounting	BA-400	5.5	—
1305086	Obsolete—contact Eaton	414D227G08	Mounting	BA-400	8.3	—
1305087	Obsolete—contact Eaton	414D227G09	Mounting	BA-400	14.5	—
1305088	Obsolete—contact Eaton	414D227G10	Mounting	BA-400	15.5	—
1305089	Obsolete—contact Eaton	414D227G11	Mounting	BA-400	25.5	—

Appendix 2—Superseded Style Number Index

Westinghouse 6/7 Digit Style Number	Eaton Catalog Number	Eaton 10 Digit Style Number	Description	Type	Voltage Rating kV Max.	Current Rating Amperes
1305090	Obsolete—contact Eaton	414D227G12	Mounting	BA-400	5.5	—
1305091	Obsolete—contact Eaton	414D227G13	Mounting	BA-400	8.3	—
1305092	Obsolete—contact Eaton	414D227G14	Mounting	BA-400	14.5	—
1305093	Obsolete—contact Eaton	414D227G15	Mounting	BA-400	15.5	—
1305094	Obsolete—contact Eaton	414D227G16	Mounting	BA-400	25.5	—
1305095	Obsolete—contact Eaton	414D227G17	Disconnect mounting RCV	BA-400	5.5	—
1305096	Obsolete—contact Eaton	414D227G18	Disconnect mounting RCV	BA-400	8.3	—
1305097	Obsolete—contact Eaton	414D227G19	Disconnect mounting RCV	BA-400	14.5	—
1305098	Obsolete—contact Eaton	414D227G20	Disconnect mounting RCV	BA-400	15.5	—
1305099	Obsolete—contact Eaton	414D227G21	Mounting	BA-400	25.5	—
1305318	Obsolete—contact Eaton	304C437G01	Mounting	BA-200	8.3	—
1305319	Obsolete—contact Eaton	304C437G02	Mounting	BA-200	15.5	—
1305320	Obsolete—contact Eaton	304C437G03	Mounting	BA-200	25.5	—
1305321	Obsolete—contact Eaton	304C437G04	Mounting	BA-200	38	—
1305326	Obsolete—contact Eaton	304C444G01	Disconnect mounting ECD	BA-400	8.3	—
1305327	Obsolete—contact Eaton	304C444G02	Disconnect mounting ECD	BA-400	15.5	—
1305328	Obsolete—contact Eaton	304C444G03	Disconnect mounting ECD	BA-400	25.5	—
1305329	Obsolete—contact Eaton	304C444G04	Disconnect mounting ECD	BA-400	38	—
1305334	Obsolete—contact Eaton	304C438G01	Disconnect mounting ECD	BA-200	8.3	—
1305335	Obsolete—contact Eaton	304C438G02	Disconnect mounting ECD	BA-200	15.5	—
1305336	Obsolete—contact Eaton	304C438G03	Disconnect mounting ECD	BA-200	25.5	—
1305337	Obsolete—contact Eaton	304C438G04	Disconnect mounting ECD	BA-200	38	—
1305432	Obsolete—contact Eaton	432D140A02	Mounting	BAL	5.5	—
1305437	Obsolete—contact Eaton	432D140A32	Mounting	BAL	2.75	—
1305438	Obsolete—contact Eaton	432D140A33	Mounting	BAL	5.5	—
1305445	72DBA2-200E	11A8127G16	—	—	—	—
1305445	92DBA2-200E	11A8127G36	—	—	—	—
1305445	121DBA2-200E	11A8127G56	—	—	—	—
1310755	Obsolete—contact Eaton	—	Mounting	BAL-100	25.5	—
1310996	Obsolete—contact Eaton	310C197G04	Condenser (outdoor)	BA-400	—	—
1310997	Obsolete—contact Eaton	310C197G03	Condenser (outdoor)	BA-200	—	—
1314000	8BA2-.5E	117D123A01	Fuse refill unit	BA-200	8.3	0.5
1314001	8BA2-5E	117D123A02	Fuse refill unit	BA-200	8.3	5
1314002	8BA2-7E	117D123A03	Fuse refill unit	BA-200	8.3	7
1314003	8BA2-10E	117D123A04	Fuse refill unit	BA-200	8.3	10
1314004	8BA2-15E	117D123A05	Fuse refill unit	BA-200	8.3	15
1314005	8BA2-20E	117D123A06	Fuse refill unit	BA-200	8.3	20
1314006	8BA2-25E	117D123A07	Fuse refill unit	BA-200	8.3	25
1314007	8BA2-30E	117D123A08	Fuse refill unit	BA-200	8.3	30
1314008	8BA2-40E	117D123A09	Fuse refill unit	BA-200	8.3	40
1314009	8BA2-50E	117D123A10	Fuse refill unit	BA-200	8.3	50
1314010	8BA2-65E	117D123A11	Fuse refill unit	BA-200	8.3	65
1314011	8BA2-80E	117D123A12	Fuse refill unit	BA-200	8.3	80
1314012	8BA2-100E	117D123A13	Fuse refill unit	BA-200	8.3	100
1314013	8BA2-125E	117D123A14	Fuse refill unit	BA-200	8.3	125
1314014	8BA2-150E	117D123A15	Fuse refill unit	BA-200	8.3	150
1314015	8BA2-200E	117D123A16	Fuse refill unit	BA-200	8.3	200
1314016	15BA2-.5E	117D123A01	Fuse refill unit	BA-200	15.5	0.5
1314017	15BA2-5E	117D123A02	Fuse refill unit	BA-200	15.5	5
1314018	15BA2-7E	117D123A03	Fuse refill unit	BA-200	15.5	7
1314019	15BA2-10E	117D123A04	Fuse refill unit	BA-200	15.5	10
1314020	15BA2-15E	117D123A05	Fuse refill unit	BA-200	15.5	15
1314021	15BA2-20E	117D123A06	Fuse refill unit	BA-200	15.5	20

Appendix 2—Superseded Style Number Index

Westinghouse 6/7 Digit Style Number	Eaton Catalog Number	Eaton 10 Digit Style Number	Description	Type	Voltage Rating kV Max.	Current Rating Amperes
1314022	15BA2-25E	117D123A07	Fuse refill unit	BA-200	15.5	25
1314023	15BA2-30E	117D123A08	Fuse refill unit	BA-200	15.5	30
1314024	15BA2-40E	117D123A09	Fuse refill unit	BA-200	15.5	40
1314025	15BA2-50E	117D123A10	Fuse refill unit	BA-200	15.5	50
1314026	15BA2-65E	117D123A11	Fuse refill unit	BA-200	15.5	654
1314027	15BA2-80E	117D123A12	Fuse refill unit	BA-200	15.5	80
1314028	15BA2-100E	117D123A13	Fuse refill unit	BA-200	15.5	100
1314029	15BA2-125E	117D123A14	Fuse refill unit	BA-200	15.5	125
1314030	15BA2-150E	117D123A15	Fuse refill unit	BA-200	15.5	150
1314031	15BA2-200E	117D123A16	Fuse refill unit	BA-200	15.5	200
1314032	25BA2-.5E	117D123A01	Fuse refill unit	BA-200	25.5	0.5
1314033	25BA2-5E	117D123A02	Fuse refill unit	BA-200	25.5	5
1314034	25BA2-7E	117D123A03	Fuse refill unit	BA-200	25.5	7
1314035	25BA2-10E	117D123A04	Fuse refill unit	BA-200	25.5	10
1314036	25BA2-15E	117D123A05	Fuse refill unit	BA-200	25.5	15
1314037	25BA2-20E	117D123A06	Fuse refill unit	BA-200	25.5	20
1314038	25BA2-25E	117D123A07	Fuse refill unit	BA-200	25.5	25
1314039	25BA2-30E	117D123A08	Fuse refill unit	BA-200	25.5	30
1314040	25BA2-40E	117D123A09	Fuse refill unit	BA-200	25.5	40
1314041	25BA2-50E	117D123A10	Fuse refill unit	BA-200	25.5	50
1314042	25BA2-65E	117D123A11	Fuse refill unit	BA-200	25.5	654
1314043	25BA2-80E	117D123A12	Fuse refill unit	BA-200	25.5	80
1314044	25BA2-100E	117D123A13	Fuse refill unit	BA-200	25.5	100
1314045	25BA2-125E	117D123A14	Fuse refill unit	BA-200	25.5	125
1314046	25BA2-150E	117D123A15	Fuse refill unit	BA-200	25.5	150
1314047	25BA2-200E	117D123A16	Fuse refill unit	BA-200	25.5	200
1314048	38BA2-.5E	117D123A01	Fuse refill unit	BA-200	38	0.5
1314049	38BA2-5E	117D123A02	Fuse refill unit	BA-200	38	5
1314050	38BA2-7E	117D123A03	Fuse refill unit	BA-200	38	7
1314051	38BA2-10E	117D123A04	Fuse refill unit	BA-200	38	10
1314052	38BA2-15E	117D123A05	Fuse refill unit	BA-200	38	15
1314053	38BA2-20E	117D123A06	Fuse refill unit	BA-200	38	20
1314054	38BA2-25E	117D123A07	Fuse refill unit	BA-200	38	25
1314055	38BA2-30E	117D123A08	Fuse refill unit	BA-200	38	30
1314056	38BA2-40E	117D123A09	Fuse refill unit	BA-200	38	40
1314057	38BA2-50E	117D123A10	Fuse refill unit	BA-200	38	50
1314058	38BA2-65E	117D123A11	Fuse refill unit	BA-200	38	654
1314059	38BA2-80E	117D123A12	Fuse refill unit	BA-200	38	80
1314060	38BA2-100E	117D123A13	Fuse refill unit	BA-200	38	100
1314061	38BA2-125E	117D123A14	Fuse refill unit	BA-200	38	125
1314062	38BA2-150E	117D123A15	Fuse refill unit	BA-200	38	150
1314063	38BA2-200E	117D123A16	Fuse refill unit	BA-200	38	200
1314067	Obsolete—contact Eaton	434D316A04	Time lag fuse refill unit	BA-200	8.3	15
1314068	Obsolete—contact Eaton	434D316A05	Time lag fuse refill unit	BA-200	8.3	20
1314069	Obsolete—contact Eaton	434D316A06	Time lag fuse refill unit	BA-200	8.3	25
1314070	Obsolete—contact Eaton	434D316A07	Time lag fuse refill unit	BA-200	8.3	30
1314071	Obsolete—contact Eaton	434D316A08	Time lag fuse refill unit	BA-200	8.3	40
1314072	Obsolete—contact Eaton	434D316A09	Time lag fuse refill unit	BA-200	8.3	50
1314073	Obsolete—contact Eaton	434D316A10	Time lag fuse refill unit	BA-200	8.3	654
1314074	Obsolete—contact Eaton	434D316A11	Time lag fuse refill unit	BA-200	8.3	80
1314075	Obsolete—contact Eaton	434D316A12	Time lag fuse refill unit	BA-200	8.3	100
1314076	Obsolete—contact Eaton	434D316A13	Time lag fuse refill unit	BA-200	8.3	125
1314077	Obsolete—contact Eaton	434D316A14	Time lag fuse refill unit	BA-200	8.3	150

Appendix 2—Superseded Style Number Index

Westinghouse 6/7 Digit Style Number	Eaton Catalog Number	Eaton 10 Digit Style Number	Description	Type	Voltage Rating kV Max.	Current Rating Amperes
1314078	Obsolete—contact Eaton	434D316A15	Time lag fuse refill unit	BA-200	8.3	200
1314082	Obsolete—contact Eaton	434D316A19	Time lag fuse refill unit	BA-200	15.5	15
1314083	Obsolete—contact Eaton	434D316A20	Time lag fuse refill unit	BA-200	15.5	20
1314084	Obsolete—contact Eaton	434D316A21	Time lag fuse refill unit	BA-200	15.5	25
1314085	Obsolete—contact Eaton	434D316A22	Time lag fuse refill unit	BA-200	15.5	30
1314086	Obsolete—contact Eaton	434D316A23	Time lag fuse refill unit	BA-200	15.5	40
1314087	Obsolete—contact Eaton	434D316A24	Time lag fuse refill unit	BA-200	15.5	50
1314088	Obsolete—contact Eaton	434D316A25	Time lag fuse refill unit	BA-200	15.5	654
1314089	Obsolete—contact Eaton	434D316A26	Time lag fuse refill unit	BA-200	15.5	80
1314090	Obsolete—contact Eaton	434D316A27	Time lag fuse refill unit	BA-200	15.5	100
1314091	Obsolete—contact Eaton	434D316A28	Time lag fuse refill unit	BA-200	15.5	125
1314092	Obsolete—contact Eaton	434D316A29	Time lag fuse refill unit	BA-200	15.5	150
1314093	Obsolete—contact Eaton	434D316A30	Time lag fuse refill unit	BA-200	15.5	200
1314097	Obsolete—contact Eaton	434D316A34	Time lag fuse refill unit	BA-200	25.5	15
1314098	Obsolete—contact Eaton	434D316A35	Time lag fuse refill unit	BA-200	25.5	20
1314099	Obsolete—contact Eaton	434D316A36	Time lag fuse refill unit	BA-200	25.5	25
1314100	Obsolete—contact Eaton	434D316A37	Time lag fuse refill unit	BA-200	25.5	30
1314101	Obsolete—contact Eaton	434D316A38	Time lag fuse refill unit	BA-200	25.5	40
1314102	Obsolete—contact Eaton	434D316A39	Time lag fuse refill unit	BA-200	25.5	50
1314103	Obsolete—contact Eaton	434D316A40	Time lag fuse refill unit	BA-200	25.5	654
1314104	Obsolete—contact Eaton	434D316A41	Time lag fuse refill unit	BA-200	25.5	80
1314105	Obsolete—contact Eaton	434D316A42	Time lag fuse refill unit	BA-200	25.5	100
1314106	Obsolete—contact Eaton	434D316A43	Time lag fuse refill unit	BA-200	25.5	125
1314107	Obsolete—contact Eaton	434D316A44	Time lag fuse refill unit	BA-200	25.5	150
1314108	Obsolete—contact Eaton	434D316A45	Time lag fuse refill unit	BA-200	25.5	200
1314112	Obsolete—contact Eaton	434D316A49	Time lag fuse refill unit	BA-200	38	15
1314113	Obsolete—contact Eaton	434D316A50	Time lag fuse refill unit	BA-200	38	20
1314114	Obsolete—contact Eaton	434D316A51	Time lag fuse refill unit	BA-200	38	25
1314115	Obsolete—contact Eaton	434D316A52	Time lag fuse refill unit	BA-200	38	30
1314116	Obsolete—contact Eaton	434D316A53	Time lag fuse refill unit	BA-200	38	40
1314117	Obsolete—contact Eaton	434D316A54	Time lag fuse refill unit	BA-200	38	50
1314118	Obsolete—contact Eaton	434D316A55	Time lag fuse refill unit	BA-200	38	654
1314119	Obsolete—contact Eaton	434D316A56	Time lag fuse refill unit	BA-200	38	80
1314120	Obsolete—contact Eaton	434D316A57	Time lag fuse refill unit	BA-200	38	100
1314121	Obsolete—contact Eaton	434D316A58	Time lag fuse refill unit	BA-200	38	125
1314122	Obsolete—contact Eaton	434D316A59	Time lag fuse refill unit	BA-200	38	150
1314123	Obsolete—contact Eaton	434D316A60	Time lag fuse refill unit	BA-200	38	200
1314124	8BA4-.5E	116D977A01	Fuse refill unit	BA-400	8.3	0.5
1314125	8BA4-5E	116D977A02	Fuse refill unit	BA-400	8.3	5
1314126	8BA4-7E	116D977A03	Fuse refill unit	BA-400	8.3	7
1314127	8BA4-10E	116D977A04	Fuse refill unit	BA-400	8.3	10
1314128	8BA4-15E	116D977A05	Fuse refill unit	BA-400	8.3	15
1314129	8BA4-20E	116D977A06	Fuse refill unit	BA-400	8.3	20
1314130	8BA4-25E	116D977A07	Fuse refill unit	BA-400	8.3	25
1314131	8BA4-30E	116D977A08	Fuse refill unit	BA-400	8.3	30
1314132	8BA4-40E	116D977A09	Fuse refill unit	BA-400	8.3	40
1314133	8BA4-50E	116D977A10	Fuse refill unit	BA-400	8.3	50
1314134	8BA4-65E	116D977A11	Fuse refill unit	BA-400	8.3	654
1314135	8BA4-80E	116D977A12	Fuse refill unit	BA-400	8.3	80
1314136	8BA4-100E	116D977A13	Fuse refill unit	BA-400	8.3	100
1314137	8BA4-125E	116D977A14	Fuse refill unit	BA-400	8.3	125
1314138	8BA4-150E	116D977A15	Fuse refill unit	BA-400	8.3	150
1314139	8BA4-200E	116D977A16	Fuse refill unit	BA-400	8.3	200

Appendix 2—Superseded Style Number Index

Westinghouse 6/7 Digit Style Number	Eaton Catalog Number	Eaton 10 Digit Style Number	Description	Type	Voltage Rating kV Max.	Current Rating Amperes
1314140	8BA4-250E	116D977A17	Fuse refill unit	BA-400	8.3	250
1314141	8BA4-300E	116D977A18	Fuse refill unit	BA-400	8.3	300
1314142	8BA4-400E	116D977A19	Fuse refill unit	BA-400	8.3	400
1314143	15BA4-.5E	116D977A01	Fuse refill unit	BA-400	15.5	0.5
1314144	15BA4-5E	116D977A02	Fuse refill unit	BA-400	15.5	5
1314145	15BA4-7E	116D977A03	Fuse refill unit	BA-400	15.5	7
1314146	15BA4-10E	116D977A04	Fuse refill unit	BA-400	15.5	10
1314147	15BA4-15E	116D977A05	Fuse refill unit	BA-400	15.5	15
1314148	15BA4-20E	116D977A06	Fuse refill unit	BA-400	15.5	20
1314149	15BA4-25E	116D977A07	Fuse refill unit	BA-400	15.5	25
1314150	15BA4-30E	116D977A08	Fuse refill unit	BA-400	15.5	30
1314151	15BA4-40E	116D977A09	Fuse refill unit	BA-400	15.5	40
1314152	15BA4-50E	116D977A10	Fuse refill unit	BA-400	15.5	50
1314153	15BA4-65E	116D977A11	Fuse refill unit	BA-400	15.5	654
1314154	15BA4-80E	116D977A12	Fuse refill unit	BA-400	15.5	80
1314155	15BA4-100E	116D977A13	Fuse refill unit	BA-400	15.5	100
1314156	15BA4-125E	116D977A14	Fuse refill unit	BA-400	15.5	125
1314157	15BA4-150E	116D977A15	Fuse refill unit	BA-400	15.5	150
1314158	15BA4-200E	116D977A16	Fuse refill unit	BA-400	15.5	200
1314159	15BA4-250E	116D977A17	Fuse refill unit	BA-400	15.5	250
1314160	15BA4-300E	116D977A18	Fuse refill unit	BA-400	15.5	300
1314161	15BA4-400E	116D977A19	Fuse refill unit	BA-400	15.5	400
1314162	25BA4-.5E	116D977A01	Fuse refill unit	BA-400	25.5	0.5
1314163	25BA4-5E	116D977A02	Fuse refill unit	BA-400	25.5	5
1314164	25BA4-7E	116D977A03	Fuse refill unit	BA-400	25.5	7
1314165	25BA4-10E	116D977A04	Fuse refill unit	BA-400	25.5	10
1314166	25BA4-15E	116D977A05	Fuse refill unit	BA-400	25.5	15
1314167	25BA4-20E	116D977A06	Fuse refill unit	BA-400	25.5	20
1314168	25BA4-25E	116D977A07	Fuse refill unit	BA-400	25.5	25
1314169	25BA4-30E	116D977A08	Fuse refill unit	BA-400	25.5	30
1314170	25BA4-40E	116D977A09	Fuse refill unit	BA-400	25.5	40
1314171	25BA4-50E	116D977A10	Fuse refill unit	BA-400	25.5	50
1314172	25BA4-65E	116D977A11	Fuse refill unit	BA-400	25.5	654
1314173	25BA4-80E	116D977A12	Fuse refill unit	BA-400	25.5	80
1314174	25BA4-100E	116D977A13	Fuse refill unit	BA-400	25.5	100
1314175	25BA4-125E	116D977A14	Fuse refill unit	BA-400	25.5	125
1314176	25BA4-150E	116D977A15	Fuse refill unit	BA-400	25.5	150
1314177	25BA4-200E	116D977A16	Fuse refill unit	BA-400	25.5	200
1314178	25BA4-250E	116D977A17	Fuse refill unit	BA-400	25.5	250
1314179	25BA4-300E	116D977A18	Fuse refill unit	BA-400	25.5	300
1314180	38BA4-.5E	116D977A01	Fuse refill unit	BA-400	38	0.5
1314181	38BA4-5E	116D977A02	Fuse refill unit	BA-400	38	5
1314182	38BA4-7E	116D977A03	Fuse refill unit	BA-400	38	7
1314183	38BA4-10E	116D977A04	Fuse refill unit	BA-400	38	10
1314184	38BA4-15E	116D977A05	Fuse refill unit	BA-400	38	15
1314185	38BA4-20E	116D977A06	Fuse refill unit	BA-400	38	20
1314186	38BA4-25E	116D977A07	Fuse refill unit	BA-400	38	25
1314187	38BA4-30E	116D977A08	Fuse refill unit	BA-400	38	30
1314188	38BA4-40E	116D977A09	Fuse refill unit	BA-400	38	40
1314189	38BA4-50E	116D977A10	Fuse refill unit	BA-400	38	50
1314190	38BA4-65E	116D977A11	Fuse refill unit	BA-400	38	654
1314191	38BA4-80E	116D977A12	Fuse refill unit	BA-400	38	80
1314192	38BA4-100E	116D977A13	Fuse refill unit	BA-400	38	100

Appendix 2—Superseded Style Number Index

Westinghouse 6/7 Digit Style Number	Eaton Catalog Number	Eaton 10 Digit Style Number	Description	Type	Voltage Rating kV Max.	Current Rating Amperes
1314193	38BA4-125E	116D977A14	Fuse refill unit	BA-400	38	125
1314194	38BA4-150E	116D977A15	Fuse refill unit	BA-400	38	150
1314195	38BA4-200E	116D977A16	Fuse refill unit	BA-400	38	200
1314196	38BA4-250E	116D977A18	Fuse refill unit	BA-400	38	250
1314197	38BA4-300E	116D977A17	Fuse refill unit	BA-400	38	300
1314199	38BA4-250E	116D977A18	Fuse refill unit	BA-400	38	250
1318260	38DBA2-0.5	22A6782G04	—	—	—	—
1318261	38DBA2-3E	505D420G07	—	—	—	—
1318262	38DBA2-5E	18A7330G13	—	—	—	—
1318263	38DBA2-7E	18A7330G14	—	—	—	—
1318264	38DBA2-10E	18A7330G15	—	—	—	—
1318265	38DBA2-15E	18A7330G16	—	—	—	—
1318266	38DBA2-20E	18A7330G17	—	—	—	—
1318267	38DBA2-25E	18A7330G18	—	—	—	—
1318268	38DBA2-30E	18A7330G19	—	—	—	—
1318269	38DBA2-40E	18A7330G20	—	—	—	—
1318270	38DBA2-50E	18A7330G21	—	—	—	—
1318271	38DBA2-65E	18A7330G22	—	—	—	—
1318272	38DBA2-80E	18A7330G23	—	—	—	—
1318273	38DBA2-100E	18A7330G24	—	—	—	—
1318274	38DBA2-125E	18A7330G25	—	—	—	—
1318275	38DBA2-150E	18A7330G26	—	—	—	—
1318276	38DBA2-200E	18A7330G27	—	—	—	—
1318280	48DBA2-0.5	22A6782G05	—	—	—	—
1318281	48DBA2-3E	505D420G08	—	—	—	—
1318282	48DBA2-5E	18A7330G33	—	—	—	—
1318283	48DBA2-7E	18A7330G34	—	—	—	—
1318284	48DBA2-10E	18A7330G35	—	—	—	—
1318285	48DBA2-15E	18A7330G36	—	—	—	—
1318286	48DBA2-20E	18A7330G37	—	—	—	—
1318287	48DBA2-25E	18A7330G38	—	—	—	—
1318288	48DBA2-30E	18A7330G39	—	—	—	—
1318289	48DBA2-40E	18A7330G40	—	—	—	—
1318290	48DBA2-50E	18A7330G41	—	—	—	—
1318291	48DBA2-65E	18A7330G42	—	—	—	—
1318292	48DBA2-80E	18A7330G43	—	—	—	—
1318293	48DBA2-100E	18A7330G44	—	—	—	—
1318294	48DBA2-125E	18A7330G45	—	—	—	—
1318295	48DBA2-150E	18A7330G46	—	—	—	—
1318296	48DBA2-200E	18A7330G47	—	—	—	—
1318511	8BA4-NH	310C196G01	Non-disconnect fuse holder	BA-400	8.3	400
1318512	15BA4-NH	310C196G02	Non-disconnect fuse holder	BA-400	15.5	400
1318513	8BA2-NH	310C198G01	Non-disconnect fuse holder	BA-200	8.3	200
1318514	15BA2-NH	310C198G02	Non-disconnect fuse holder	BA-200	15.5	200
1318710	2CLE-50E	310C095G02	CL fuse unit	CLE	2.75	50
	2CLE-50E	449D797G03	CL fuse unit	CLE	2.75	50
1318711	2CLE-65E	310C095G03	CL fuse unit	CLE	2.75	65
	2CLE-65E	449D797G04	CL fuse unit	CLE	2.75	65
1318712	2CLE-80E	310C095G04	CL fuse unit	CLE	2.75	90
	2CLE-80E	449D797G05	CL fuse unit	CLE	2.75	90
1318713	2CLE-100E	310C095G05	CL fuse unit	CLE	2.75	100
	2CLE-100E	449D797G06	CL fuse unit	CLE	2.75	100

Appendix 2—Superseded Style Number Index

Westinghouse 6/7 Digit Style Number	Eaton Catalog Number	Eaton 10 Digit Style Number	Description	Type	Voltage Rating kV Max.	Current Rating Amperes
1318714	2CLE-125E	310C095G06	CL fuse unit	CLE	2.75	125
	2CLE-125E	449D797G07	CL fuse unit	CLE	2.75	125
1318715	2CLE-150E	310C095G07	CL fuse unit	CLE	2.75	150
	2CLE-150E	449D797G08	CL fuse unit	CLE	2.75	150
1318716	2CLE-200E	310C095G08	CL fuse unit	CLE	2.75	200
	2CLE-200E	449D797G09	CL fuse unit	CLE	2.75	200
1318720	5CLE-50E	310C095G12	CL fuse unit	CLE	5.5	50
	5CLE-50E	5981C65G02	CL fuse unit	CLE	5.5	50
1318721	5CLE-65E	310C095G13	CL fuse unit	CLE	5.5	65
	5CLE-65E	5981C65G03	CL fuse unit	CLE	5.5	65
1318722	5CLE-80E	310C095G14	CL fuse unit	CLE	5.5	90
	5CLE-80E	5981C65G04	CL fuse unit	CLE	5.5	90
1318723	5CLE-100E	310C095G15	CL fuse unit	CLE	5.5	100
	5CLE-100E	5981C65G05	CL fuse unit	CLE	5.5	100
1318724	5CLE-125E	310C095G16	CL fuse unit	CLE	5.5	125
	5CLE-125E	5981C65G06	CL fuse unit	CLE	5.5	125
1318725	5CLE-150E	310C095G17	CL fuse unit	CLE	5.5	150
	5CLE-150E	5981C65G07	CL fuse unit	CLE	5.5	150
1318726	5CLE-200E	310C095G18	CL fuse unit	CLE	5.5	200
	5CLE-200E	5981C65G09	CL fuse unit	CLE	5.5	200
1318727	8CLE-50E	5981C17G05	CL fuse unit	CLE	8.3	50
	8CLE-50E	677C573G03	CL fuse unit	CLE	8.3	50
1318728	8CLE-65E	5981C17G06	CL fuse unit	CLE	8.3	65
	8CLE-65E	677C573G04	CL fuse unit	CLE	8.3	65
1318730	8CLE-100E	5981C17G08	CL fuse unit	CLE	8.3	100
	8CLE-100E	677C573G06	CL fuse unit	CLE	8.3	100
1318731	15CLE-50E	439D378G05	CL fuse unit	CLE	15.5	50
	15CLE-50E	5981C19G05	CL fuse unit	CLE	15.5	50
1318732	15CLE-65E	439D378G06	CL fuse unit	CLE	15.5	65
	15CLE-65E	5981C19G06	CL fuse unit	CLE	15.5	65
1318733	15CLE-80E	439D482G04	CL fuse unit	CLE	15.5	80
	15CLE-80E	5981C19G07	CL fuse unit	CLE	15.5	80
1318734	15CLE-100E	439D482G05	CL fuse unit	CLE	15.5	100
	15CLE-100E	5981C19G08	CL fuse unit	CLE	15.5	100
1318739	Obsolete—contact Eaton	505D615A02	Live parts	BA-400	—	—
1318740	Obsolete—contact Eaton	505D615A04	Live parts	BA-400	—	—
1318741	Obsolete—contact Eaton	505D615A05	Live parts	BA-400	—	—
1318742	Obsolete—contact Eaton	505D615A06	Live parts	BA-400	—	—
1318803	Obsolete—contact Eaton	505D616A03	Live parts	BA-200	—	—
1318840	Obsolete—contact Eaton	505D616A06	Live parts	BA-200	—	—
1318841	Obsolete—contact Eaton	505D616A07	Live parts	BA-200	—	—
1318842	Obsolete—contact Eaton	505D616A08	Live parts	BA-200	—	—
1318843	Obsolete—contact Eaton	505D616A09	Live parts	BA-200	—	—
1332763	2CLE-15E	678C240G01	CL fuse unit	CLE	2.75	15
1332764	2CLE-20E	678C240G02	CL fuse unit	CLE	2.75	20
1332765	2CLE-25E	678C240G03	CL fuse unit	CLE	2.75	25
1332766	5CLE-15E	678C240G04	CL fuse unit	CLE	5.5	15
1332767	5CLE-20E	678C240G05	CL fuse unit	CLE	5.5	20
1332768	5CLE-25E	678C240G06	CL fuse unit	CLE	5.5	25
1332769	8CLE-15E	678C240G07	CL fuse unit	CLE	8.3	15
1332770	8CLE-20E	678C240G08	CL fuse unit	CLE	8.3	20
1332771	8CLE-25E	678C240G09	CL fuse unit	CLE	8.3	25
1332772	15CLE-15E	678C240G10	CL fuse unit	CLE	15.5	15

Appendix 2—Superseded Style Number Index

Westinghouse 6/7 Digit Style Number	Eaton Catalog Number	Eaton 10 Digit Style Number	Description	Type	Voltage Rating kV Max.	Current Rating Amperes
1332773	15CLE-20E	678C240G11	CL fuse unit	CLE	15.5	20
1332774	15CLE-25E	678C240G12	CL fuse unit	CLE	15.5	25
1362998	Obsolete—contact Eaton	—	End fittings	CLE	—	—
1363084	Obsolete—contact Eaton	505D615A03	Live parts	BA-400	—	—
1392538	2CLS-2R	591C812G02	CL fuse unit	CLS	2.54	70
1392539	2CLS-4R	591C812G04	CL fuse unit	CLS	2.54	130
1392540	2CLS-6R	591C812G06	CL fuse unit	CLS	2.54	170
1392541	2CLS-9R	591C812G07	CL fuse unit	CLS	2.54	200
1392542	2CLS-12R	591C812G08	CL fuse unit	CLS	2.54	230
1392543	2CLS-12R	591C812G08	CL fuse unit	CLS	2.54	230
1392544	5LCLS-2R	676C546G15	CL fuse unit	CLS	5.08	70
1392545	5LCLS-4R	676C546G17	CL fuse unit	CLS	5.08	130
1392546	5LCLS-6R	676C546G19	CL fuse unit	CLS	5.08	170
1392547	5LCLS-9R	676C546G22	CL fuse unit	CLS	5.08	200
1392548	5LCLS-12R	676C546G25	CL fuse unit	CLS	5.08	230
1392549	5LCLS-12R	676C546G25	CL fuse unit	CLS	5.08	230
1392788	Obsolete—contact Eaton	432D140A35	Mounting	BAL	—	—
1404766	8BAZ-NH	310C198G01	Non-disconnect fuse holder	BA-200	8.3	200
1404767	15BAZ-NH	310C198G02	Non-disconnect fuse holder	BA-200	15.5	200
1414114	Obsolete—contact Eaton	434D316A51	Time lag fuse refill unit	BA-200	38	25
1446152	Obsolete—contact Eaton	304C108G01	Outdoor mounting 180	BA-200	8.3	200
1446153	Obsolete—contact Eaton	304C108G02	Outdoor mounting 180	BA-200	15.5	200
1446154	Obsolete—contact Eaton	304C108G03	Outdoor mounting 180	BA-200	25.5	200
1446155	Obsolete—contact Eaton	304C108G04	Outdoor mounting 180	BA-200	38	200
1446156	Obsolete—contact Eaton	304C109G01	Outdoor mounting 180	BA-400	8.3	400
1446157	Obsolete—contact Eaton	304C109G02	Outdoor mounting 180	BA-400	15.5	400
1446158	Obsolete—contact Eaton	304C109G03	Outdoor mounting 180	BA-400	25.5	400
1446159	Obsolete—contact Eaton	304C109G04	Outdoor mounting 180	BA-400	38	400
1446293	Obsolete—contact Eaton	434D830A01	Outdoor mounting	DBA-1	8.3	200
1446294	Obsolete—contact Eaton	434D830A02	Outdoor mounting	DBA-1	15.5	200
1446295	Obsolete—contact Eaton	434D830A03	Outdoor mounting	DBA-1	25.5	200
1446296	Obsolete—contact Eaton	434D830A04	Outdoor mounting	DBA-1	38	200
1446297	Obsolete—contact Eaton	434D830A05	Outdoor mounting	DBA-1	48	200
1446298	Obsolete—contact Eaton	434D830A09	Outdoor mounting	DBA-1	72	200
1446355	Obsolete—contact Eaton	434D831A02	Outdoor mounting	DBA2/5	48	200
1446356	Obsolete—contact Eaton	434D831A09	Outdoor mounting	DBA2/5	72	200
1446357	Obsolete—contact Eaton	434D831A10	Outdoor mounting	DBA2/5	92	200
1446358	Obsolete—contact Eaton	434D831A11	Outdoor mounting	DBA2/5	121	200
1446359	Obsolete—contact Eaton	434D831A12	Outdoor mounting	DBA2/5	145	200
1481432	Obsolete—contact Eaton	304C108G05	Outdoor mounting Hi BIL	BA-200	8.3	200
1481433	Obsolete—contact Eaton	304C108G06	Outdoor mounting Hi BIL	BA-200	15.5	200
1481434	Obsolete—contact Eaton	304C108G07	Outdoor mounting Hi BIL	BA-200	25.5	200
1481435	Obsolete—contact Eaton	304C108G08	Outdoor mounting Hi BIL	BA-200	38	200
1481436	Obsolete—contact Eaton	314C109G05	Outdoor mounting Hi BIL	BA-400	8.3	400
1481437	Obsolete—contact Eaton	314C109G06	Outdoor mounting Hi BIL	BA-400	15.5	400
1481438	Obsolete—contact Eaton	314C109G07	Outdoor mounting Hi BIL	BA-400	25.5	400
1481439	Obsolete—contact Eaton	314C109G08	Outdoor mounting Hi BIL	BA-400	38	400
1482184	Obsolete—contact Eaton	505D620A02	Live parts	BA-200	—	—
1482185	Obsolete—contact Eaton	505D620A03	Live parts	BA-200	—	—
1482186	Obsolete—contact Eaton	505D620A04	Live parts	BA-200	—	—
1482187	Obsolete—contact Eaton	505D620A05	Live parts	BA-200	—	—
1482193	Obsolete—contact Eaton	505D620A01	Live parts	BA-200	—	—
1482194	Obsolete—contact Eaton	505D620A06	Live parts	BA-200	—	—

Appendix 2—Superseded Style Number Index

Westinghouse 6/7 Digit Style Number	Eaton Catalog Number	Eaton 10 Digit Style Number	Description	Type	Voltage Rating kV Max.	Current Rating Amperes
1482195	Obsolete—contact Eaton	505D620A07	Live parts	BA-200	—	—
1482196	Obsolete—contact Eaton	505D620A08	Live parts	BA-200	—	—
1491006	Obsolete—contact Eaton	414D224G06	Mounting	BA-400	38	—
1491007	Obsolete—contact Eaton	414D226G06	Mounting	BA-400	38	—
1491008	Obsolete—contact Eaton	414D225G06	Mounting	BA-400	38	—
1491009	Obsolete—contact Eaton	414D227G06	Mounting	BA-400	38	—
1491043	Obsolete—contact Eaton	505D615A07	Live parts	BA-200	—	—
1491044	Obsolete—contact Eaton	505D615A08	Live parts	BA-200	—	—
1491045	Obsolete—contact Eaton	505D615A09	Live parts	BA-200	—	—
1491046	Obsolete—contact Eaton	505D615A10	Live parts	BA-200	—	—
1491052	15CLPT-1.5E	677C452G10	CL fuse unit	CLE-PT	15.5	1.5
1508801	Obsolete—contact Eaton	676C236A01	Mounting	BAL-PT	5.5	10
1508802	Obsolete—contact Eaton	676C236A02	Mounting	BAL-PT	7.2	—
1508803	Obsolete—contact Eaton	676C236A03	Mounting	BAL-PT	7.2	—
1508804	Obsolete—contact Eaton	676C236A04	Mounting	BAL-PT	15.5	—
1508805	Obsolete—contact Eaton	676C236A05	Mounting	BAL-PT	15.5	—
1508806	Obsolete—contact Eaton	676C236A06	Mounting	BAL-PT	25.5	—
1508807	Obsolete—contact Eaton	676C236A11	Mounting	BAL-PT	5.5	—
1508808	Obsolete—contact Eaton	676C236A12	Mounting	BAL-PT	7.2	—
1508809	Obsolete—contact Eaton	676C236A13	Mounting	BAL-PT	7.2	—
1508810	Obsolete—contact Eaton	676C236A14	Mounting	BAL-PT	15.5	—
1508811	Obsolete—contact Eaton	676C236A15	Mounting	BAL-PT	15.5	—
1508812	Obsolete—contact Eaton	676C236A16	Mounting	BAL-PT	25.5	—
1508813	Obsolete—contact Eaton	676C236A21	Mounting	BAL-PT	5.5	—
1508814	Obsolete—contact Eaton	676C236A22	Mounting	BAL-PT	7.2	—
1508815	Obsolete—contact Eaton	676C236A23	Mounting	BAL-PT	7.2	—
1508816	Obsolete—contact Eaton	676C236A24	Mounting	BAL-PT	15.5	—
1508817	Obsolete—contact Eaton	676C236A25	Mounting	BAL-PT	15.5	—
1508818	Obsolete—contact Eaton	676C236A26	Mounting	BAL-PT	25.5	—
1508820	Obsolete—contact Eaton	676C233A01	Mounting	BAL-PT	5.5	—
1508821	Obsolete—contact Eaton	676C233A02	Mounting	BAL-PT	7.2	—
1508822	Obsolete—contact Eaton	676C233A03	Mounting	BAL-PT	7.2	—
1508823	Obsolete—contact Eaton	676C233A04	Mounting	BAL-PT	15.5	—
1508824	Obsolete—contact Eaton	676C233A05	Mounting	BAL-PT	15.5	—
1508825	Obsolete—contact Eaton	676C233A06	Mounting	BAL-PT	25.5	—
1508826	Obsolete—contact Eaton	676C233A09	Mounting	BAL-PT	5.5	—
1508827	Obsolete—contact Eaton	676C233A10	Mounting	BAL-PT	7.2	—
1508828	Obsolete—contact Eaton	676C233A11	Mounting	BAL-PT	7.2	—
1508829	Obsolete—contact Eaton	676C233A12	Mounting	BAL-PT	15.5	—
1508830	Obsolete—contact Eaton	676C233A13	Mounting	BAL-PT	15.5	—
1508831	Obsolete—contact Eaton	676C233A14	Mounting	BAL-PT	25.5	—
1508832	Obsolete—contact Eaton	676C233A17	Mounting	BAL-PT	5.5	—
1508833	Obsolete—contact Eaton	676C233A18	Mounting	BAL-PT	7.2	—
1508834	Obsolete—contact Eaton	676C233A19	Mounting	BAL-PT	7.2	—
1508835	Obsolete—contact Eaton	676C233A20	Mounting	BAL-PT	15.5	—
1508836	Obsolete—contact Eaton	676C233A21	Mounting	BAL-PT	15.5	—
1508837	Obsolete—contact Eaton	676C233A22	Mounting	BAL-PT	25.5	—
1508838	Obsolete—contact Eaton	676C233A25	Mounting	BAL-PT	5.5	—
1508839	Obsolete—contact Eaton	676C233A26	Mounting	BAL-PT	7.2	—
1508841	Obsolete—contact Eaton	676C233A28	Mounting	BAL-PT	15.5	—
1508842	Obsolete—contact Eaton	676C233A29	Mounting	BAL-PT	15.5	—
1508845	Obsolete—contact Eaton	676C237A01	Mounting	BAL-10	8.3	—
1508846	Obsolete—contact Eaton	676C237A02	Mounting	BAL-10	8.3	—

Appendix 2—Superseded Style Number Index

Westinghouse 6/7 Digit Style Number	Eaton Catalog Number	Eaton 10 Digit Style Number	Description	Type	Voltage Rating kV Max.	Current Rating Amperes
1508847	Obsolete—contact Eaton	676C237A03	Mounting	BAL-10	15.5	—
1508848	Obsolete—contact Eaton	676C237A04	Mounting	BAL-10	15.5	—
1508849	Obsolete—contact Eaton	676C237A11	Mounting	BAL-10	8.3	—
1508850	Obsolete—contact Eaton	676C237A12	Mounting	BAL-10	8.3	—
1508851	Obsolete—contact Eaton	676C237A13	Mounting	BAL-10	15.5	—
1508852	Obsolete—contact Eaton	676C237A14	Mounting	BAL-10	15.5	—
1508853	Obsolete—contact Eaton	676C237A21	Mounting	BAL-10	8.3	—
1508854	Obsolete—contact Eaton	676C237A22	Mounting	BAL-10	8.3	—
1508855	Obsolete—contact Eaton	676C237A23	Mounting	BAL-10	15.5	—
1508856	Obsolete—contact Eaton	676C237A24	Mounting	BAL-10	15.5	—
1508858	Obsolete—contact Eaton	676C234A01	Mounting	BAL-10	8.3	—
1508859	Obsolete—contact Eaton	676C234A02	Mounting	BAL-10	8.3	—
1508860	Obsolete—contact Eaton	676C234A03	Mounting	BAL-10	15.5	—
1508861	Obsolete—contact Eaton	676C234A04	Mounting	BAL-10	15.5	—
1508862	Obsolete—contact Eaton	676C234A09	Mounting	BAL-10	8.3	—
1508863	Obsolete—contact Eaton	676C234A10	Mounting	BAL-10	8.3	—
1508864	Obsolete—contact Eaton	676C234A11	Mounting	BAL-10	15.5	—
1508865	Obsolete—contact Eaton	676C234A12	Mounting	BAL-10	15.5	—
1508866	Obsolete—contact Eaton	676C234A17	Mounting	BAL-10	8.3	—
1508867	Obsolete—contact Eaton	676C234A18	Mounting	BAL-10	8.3	—
1508868	Obsolete—contact Eaton	676C234A19	Mounting	BAL-10	15.5	—
1508869	Obsolete—contact Eaton	676C234A20	Mounting	BAL-10	15.5	—
1508870	Obsolete—contact Eaton	676C234A26	Mounting	BAL-10	8.3	—
1508871	Obsolete—contact Eaton	676C234A27	Mounting	BAL-10	8.3	—
1508872	Obsolete—contact Eaton	676C234A28	Mounting	BAL-10	15.5	—
1508873	Obsolete—contact Eaton	676C234A29	Mounting	BAL-10	15.5	—
1508875	Obsolete—contact Eaton	676C238A01	Mounting	BAL-25	2.75	—
1508876	Obsolete—contact Eaton	676C238A02	Mounting	BAL-25	5.5	—
1508877	Obsolete—contact Eaton	676C238A03	Mounting	BAL-25	5.5	—
1508878	Obsolete—contact Eaton	676C238A04	Mounting	BAL-25	5.5	—
1508879	Obsolete—contact Eaton	676C238A05	Mounting	BAL-25	8.3	—
1508880	Obsolete—contact Eaton	676C238A06	Mounting	BAL-25	8.3	—
1508881	Obsolete—contact Eaton	676C238A07	Mounting	BAL-25	15.5	—
1508882	Obsolete—contact Eaton	676C238A08	Mounting	BAL-25	15.5	—
1508883	Obsolete—contact Eaton	676C238A11	Mounting	BAL-25	2.75	—
1508884	Obsolete—contact Eaton	676C238A12	Mounting	BAL-25	2.75	—
1508885	Obsolete—contact Eaton	676C238A13	Mounting	BAL-25	5.5	—
1508886	Obsolete—contact Eaton	676C238A14	Mounting	BAL-25	5.5	—
1508887	Obsolete—contact Eaton	676C238A15	Mounting	BAL-25	8.3	—
1508888	Obsolete—contact Eaton	676C238A16	Mounting	BAL-25	8.3	—
1508889	Obsolete—contact Eaton	676C238A17	Mounting	BAL-25	15.5	—
1508890	Obsolete—contact Eaton	676C238A18	Mounting	BAL-25	15.5	—
1508891	Obsolete—contact Eaton	676C238A21	Mounting	BAL-25	5.5	—
1508892	Obsolete—contact Eaton	676C238A22	Mounting	BAL-25	2.75	—
1508893	Obsolete—contact Eaton	151D244G26	Disconnect live parts RC	CLE	—	—
1508894	Obsolete—contact Eaton	676C238A24	Mounting	BAL-25	5.5	—
1508895	Obsolete—contact Eaton	676C238A25	Mounting	BAL-25	8.3	—
1508896	Obsolete—contact Eaton	676C238A26	Mounting	BAL-25	8.3	—
1508897	Obsolete—contact Eaton	676C238A27	Mounting	BAL-25	15.5	—
1508898	Obsolete—contact Eaton	676C238A28	Mounting	BAL-25	15.5	—
1508900	Obsolete—contact Eaton	676C231A01	Mounting	BAL-25	2.75	—
1508901	Obsolete—contact Eaton	676C231A02	Mounting	BAL-25	5.5	—
1508902	Obsolete—contact Eaton	676C231A03	Mounting	BAL-25	5.5	—

Appendix 2—Superseded Style Number Index

Westinghouse 6/7 Digit Style Number	Eaton Catalog Number	Eaton 10 Digit Style Number	Description	Type	Voltage Rating kV Max.	Current Rating Amperes
1508903	Obsolete—contact Eaton	676C231A04	Mounting	BAL-25	5.5	—
1508904	Obsolete—contact Eaton	676C231A05	Mounting	BAL-25	8.3	—
1508905	Obsolete—contact Eaton	676C231A06	Mounting	BAL-25	8.3	—
1508906	Obsolete—contact Eaton	676C231A07	Mounting	BAL-25	15.5	—
1508907	Obsolete—contact Eaton	676C231A08	Mounting	BAL-25	15.5	—
1508908	Obsolete—contact Eaton	676C231A09	Mounting	BAL-25	2.75	—
1508909	Obsolete—contact Eaton	676C231A10	Mounting	BAL-25	5.5	—
1508910	Obsolete—contact Eaton	676C231A11	Mounting	BAL-25	5.5	—
1508911	Obsolete—contact Eaton	676C231A12	Mounting	BAL-25	5.5	—
1508912	Obsolete—contact Eaton	676C231A13	Mounting	BAL-25	8.3	—
1508913	Obsolete—contact Eaton	676C231A14	Mounting	BAL-25	8.3	—
1508914	Obsolete—contact Eaton	676C231A15	Mounting	BAL-25	15.5	—
1508915	Obsolete—contact Eaton	676C231A16	Mounting	BAL-25	15.5	—
1508916	Obsolete—contact Eaton	676C231A17	Mounting	BAL-25	2.75	—
1508917	Obsolete—contact Eaton	676C231A18	Mounting	BAL-25	5.5	—
1508918	Obsolete—contact Eaton	676C231A19	Mounting	BAL-25	5.5	—
1508919	Obsolete—contact Eaton	676C231A20	Mounting	BAL-25	5.5	—
1508920	Obsolete—contact Eaton	676C231A21	Mounting	BAL-25	8.3	—
1508921	Obsolete—contact Eaton	676C231A22	Mounting	BAL-25	8.3	—
1508922	Obsolete—contact Eaton	676C231A23	Mounting	BAL-25	15.5	—
1508923	Obsolete—contact Eaton	676C231A24	Mounting	BAL-25	15.5	—
1508924	Obsolete—contact Eaton	676C231A25	Mounting	BAL-25	2.75	—
1508925	Obsolete—contact Eaton	676C231A26	Mounting	BAL-25	5.5	—
1508926	Obsolete—contact Eaton	676C231A27	Mounting	BAL-25	5.5	—
1508927	Obsolete—contact Eaton	676C231A28	Mounting	BAL-25	5.5	—
1508928	Obsolete—contact Eaton	676C231A29	Mounting	BAL-25	8.3	—
1508929	Obsolete—contact Eaton	676C231A30	Mounting	BAL-25	8.3	—
1508930	Obsolete—contact Eaton	676C231A31	Mounting	BAL-25	15.5	—
1508931	Obsolete—contact Eaton	676C231A32	Mounting	BAL-25	15.5	—
1508933	Obsolete—contact Eaton	308C427A01	Mounting	BAL-200	2.75	—
1508934	Obsolete—contact Eaton	308C427A02	Mounting	BAL-200	5.5	—
1508935	Obsolete—contact Eaton	308C427A03	Mounting	BAL-200	5.5	—
1508936	Obsolete—contact Eaton	308C427A04	Mounting	BAL-200	8.3	—
1508937	Obsolete—contact Eaton	308C427A05	Mounting	BAL-200	8.3	—
1508938	Obsolete—contact Eaton	308C427A06	Mounting	BAL-200	15.5	—
1508939	15CLE-HPNM-D	9078A68G19	CLE mounting	CLE-1	15.5	—
1508940	Obsolete—contact Eaton	308C427A10	CLE mounting, rear connected	CLE-1	2.75	—
1508941	Obsolete—contact Eaton	308C427A11	CLE mounting	CLE-1	5.5	—
1508942	Obsolete—contact Eaton	308C427A12	CLE mounting	CLE-1	5.5	—
1508943	Obsolete—contact Eaton	308C427A13	CLE mounting	CLE-1	8.3	—
1508944	Obsolete—contact Eaton	308C427A14	CLE mounting	CLE-1	8.3	—
1508945	Obsolete—contact Eaton	308C427A15	CLE mounting	CLE-1	15.5	—
1508946	Obsolete—contact Eaton	308C427A16	CLE mounting	CLE-1	15.5	—
1508947	Obsolete—contact Eaton	308C427A19	CLE mounting	CLE-1	2.75	—
1508948	Obsolete—contact Eaton	308C427A20	CLE mounting	CLE-1	5.5	—
1508949	Obsolete—contact Eaton	308C427A21	CLE mounting	CLE-1	5.5	—
1508950	Obsolete—contact Eaton	308C427A22	CLE mounting	CLE-1	8.3	—
1508951	Obsolete—contact Eaton	308C427A23	CLE mounting	CLE-1	8.3	—
1508952	Obsolete—contact Eaton	308C427A24	CLE mounting	CLE-1	15.5	—
1508953	Obsolete—contact Eaton	308C427A25	CLE mounting	CLE-1	15.5	—
1508954	Obsolete—contact Eaton	151D907G25	Live parts, rear connected	CLE-1	—	—
1508955	—	432D140A01	CLE mounting	CLE-1	2.75	—
1508956	—	432D140A02	CLE mounting	CLE-1	5.5	—

Appendix 2—Superseded Style Number Index

Westinghouse 6/7 Digit Style Number	Eaton Catalog Number	Eaton 10 Digit Style Number	Description	Type	Voltage Rating kV Max.	Current Rating Amperes
1508957	—	432D140A05	CLE mounting	CLE-1	5.5	—
1508958	—	432D140A06	CLE mounting	CLE-1	8.3	—
1508959	—	432D140A09	CLE mounting	CLE-1	8.3	—
1508960	—	432D140A10	CLE mounting	CLE-1	15.5	—
1508961	—	432D140A11	CLE mounting	CLE-1	15.5	—
1508962	—	432D140A12	CLE mounting	CLE-1	2.75	—
1508963	—	432D140A13	CLE mounting	CLE-1	5.5	—
1508964	—	432D140A15	CLE mounting	CLE-1	5.5	—
1508965	—	432D140A16	CLE mounting	CLE-1	8.3	—
1508966	—	432D140A19	CLE mounting	CLE-1	8.3	—
1508967	—	432D140A20	CLE mounting	CLE-1	15.5	—
1508968	—	432D140A21	CLE mounting	CLE-1	15.5	—
1508969	—	432D140A22	CLE mounting	CLE-1	2.75	—
1508970	—	432D140A23	CLE mounting	CLE-1	5.5	—
1508971	—	432D140A25	CLE mounting	CLE-1	5.5	—
1508972	—	432D140A26	CLE mounting	CLE-1	8.3	—
1508973	—	432D140A29	CLE mounting	CLE-1	8.3	—
1508974	—	432D140A30	CLE mounting	CLE-1	15.5	—
1508975	—	432D140A31	CLE mounting	CLE-1	15.5	—
1508976	—	432D140A32	CLE mounting	CLE-1	2.75	—
1508977	—	432D140A33	CLE mounting	CLE-1	5.5	—
1508978	—	432D140A35	CLE mounting	CLE-1	5.5	—
1508979	—	432D140A36	CLE mounting	CLE-1	8.3	—
1508980	—	432D140A39	CLE mounting	CLE-1	8.3	—
1508981	—	432D140A40	CLE mounting	CLE-1	15.5	—
1508982	—	432D140A41	CLE mounting	CLE-1	15.5	—
1529011	Obsolete—contact Eaton	—	Time lag fuse unit	DBA-2	72	15
1529012	Obsolete—contact Eaton	—	Time lag fuse unit	DBA-2	72	20
1529013	Obsolete—contact Eaton	—	Time lag fuse unit	DBA-2	72	25
1529014	Obsolete—contact Eaton	—	Time lag fuse unit	DBA-2	72	30
1529015	Obsolete—contact Eaton	—	Time lag fuse unit	DBA-2	72	40
1529016	Obsolete—contact Eaton	—	Time lag fuse unit	DBA-2	72	50
1529017	Obsolete—contact Eaton	—	Time lag fuse unit	DBA-2	72	65
1529018	Obsolete—contact Eaton	—	Time lag fuse unit	DBA-2	72	80
1529019	Obsolete—contact Eaton	—	Time lag fuse unit	DBA-2	72	100
1529020	Obsolete—contact Eaton	—	Time lag fuse unit	DBA-2	72	125
1529021	Obsolete—contact Eaton	—	Time lag fuse unit	DBA-2	72	150
1529022	Obsolete—contact Eaton	—	Time lag fuse unit	DBA-2	72	200
1529074	Obsolete—contact Eaton	434D317A05	Time lag fuse refill unit	BA-400	8.3	20
1529075	Obsolete—contact Eaton	434D317A06	Time lag fuse refill unit	BA-400	8.3	25
1529076	Obsolete—contact Eaton	434D317A07	Time lag fuse refill unit	BA-400	8.3	30
1529077	Obsolete—contact Eaton	434D317A08	Time lag fuse refill unit	BA-400	8.3	40
1529078	Obsolete—contact Eaton	434D317A09	Time lag fuse refill unit	BA-400	8.3	50
1529079	Obsolete—contact Eaton	434D317A10	Time lag fuse refill unit	BA-400	8.3	65
1529080	Obsolete—contact Eaton	434D317A11	Time lag fuse refill unit	BA-400	8.3	80
1529081	Obsolete—contact Eaton	434D317A12	Time lag fuse refill unit	BA-400	8.3	100
1529082	Obsolete—contact Eaton	434D317A13	Time lag fuse refill unit	BA-400	8.3	125
1529083	Obsolete—contact Eaton	434D317A14	Time lag fuse refill unit	BA-400	8.3	150
1529084	Obsolete—contact Eaton	434D317A15	Time lag fuse refill unit	BA-400	8.3	200
1529085	Obsolete—contact Eaton	434D317A23	Time lag fuse refill unit	BA-400	15.5	20
1529086	Obsolete—contact Eaton	434D317A24	Time lag fuse refill unit	BA-400	15.5	25
1529087	Obsolete—contact Eaton	434D317A25	Time lag fuse refill unit	BA-400	15.5	30
1529088	Obsolete—contact Eaton	434D317A26	Time lag fuse refill unit	BA-400	15.5	40

Appendix 2—Superseded Style Number Index

Westinghouse 6/7 Digit Style Number	Eaton Catalog Number	Eaton 10 Digit Style Number	Description	Type	Voltage Rating kV Max.	Current Rating Amperes
1529089	Obsolete—contact Eaton	434D317A27	Time lag fuse refill unit	BA-400	15.5	50
1529090	Obsolete—contact Eaton	434D317A28	Time lag fuse refill unit	BA-400	15.5	65
1529091	Obsolete—contact Eaton	434D317A29	Time lag fuse refill unit	BA-400	15.5	80
1529092	Obsolete—contact Eaton	434D317A30	Time lag fuse refill unit	BA-400	15.5	100
1529093	Obsolete—contact Eaton	434D317A31	Time lag fuse refill unit	BA-400	15.5	125
1529094	Obsolete—contact Eaton	434D317A32	Time lag fuse refill unit	BA-400	15.5	150
1529095	Obsolete—contact Eaton	434D317A33	Time lag fuse refill unit	BA-400	15.5	200
1529096	Obsolete—contact Eaton	434D317A41	Time lag fuse refill unit	BA-400	25.5	20
1529097	Obsolete—contact Eaton	434D317A42	Time lag fuse refill unit	BA-400	25.5	25
1529098	Obsolete—contact Eaton	434D317A43	Time lag fuse refill unit	BA-400	25.5	30
1529099	Obsolete—contact Eaton	434D317A44	Time lag fuse refill unit	BA-400	25.5	40
1529100	Obsolete—contact Eaton	434D317A45	Time lag fuse refill unit	BA-400	25.5	50
1529101	Obsolete—contact Eaton	434D317A46	Time lag fuse refill unit	BA-400	25.5	65
1529102	Obsolete—contact Eaton	434D317A47	Time lag fuse refill unit	BA-400	25.5	80
1529103	Obsolete—contact Eaton	434D317A48	Time lag fuse refill unit	BA-400	25.5	100
1529104	Obsolete—contact Eaton	434D317A49	Time lag fuse refill unit	BA-400	25.5	125
1529105	Obsolete—contact Eaton	434D317A50	Time lag fuse refill unit	BA-400	25.5	150
1529106	Obsolete—contact Eaton	434D317A51	Time lag fuse refill unit	BA-400	25.5	200
1529107	Obsolete—contact Eaton	434D317A59	Time lag fuse refill unit	BA-400	38	20
1529108	Obsolete—contact Eaton	434D317A60	Time lag fuse refill unit	BA-400	38	25
1529109	Obsolete—contact Eaton	434D317A61	Time lag fuse refill unit	BA-400	38	30
1529110	Obsolete—contact Eaton	434D317A62	Time lag fuse refill unit	BA-400	38	40
1529111	Obsolete—contact Eaton	434D317A63	Time lag fuse refill unit	BA-400	38	50
1529112	Obsolete—contact Eaton	434D317A64	Time lag fuse refill unit	BA-400	38	65
1529113	Obsolete—contact Eaton	434D317A65	Time lag fuse refill unit	BA-400	38	80
1529114	Obsolete—contact Eaton	434D317A66	Time lag fuse refill unit	BA-400	38	100
1529115	Obsolete—contact Eaton	434D317A67	Time lag fuse refill unit	BA-400	38	125
1529116	Obsolete—contact Eaton	434D317A68	Time lag fuse refill unit	BA-400	38	150
1529117	Obsolete—contact Eaton	434D317A69	Time lag fuse refill unit	BA-400	38	200
1533412	Obsolete—contact Eaton	505D616A05	Live parts	BA-200	—	—
1533413	Obsolete—contact Eaton	505D616A04	Live parts	BA-200	—	—
1533505	—	676C237A05	CLE mounting	CLE-PT	5.5	10
1533506	—	676C237A15	CLE mounting	CLE-PT	5.5	10
1533507	—	676C237A25	CLE mounting	CLE-PT	5.5	10
1533508	—	676C234A05	CLE mounting	CLE-PT	5.5	10
1533509	—	676C234A13	CLE mounting	CLE-PT	5.5	10
1533510	—	676C234A21	CLE mounting	CLE-PT	5.5	10
1533511	—	676C234A30	CLE mounting	CLE-PT	5.5	10
1533754	Obsolete—contact Eaton	677C593G03	CL fuse unit	CLV	0.6	7
1533755	Obsolete—contact Eaton	677C593G04	CL fuse unit	CLV	0.6	10
1533840	2CLS-4R	676C546G04	CL fuse unit	CLS	2.54	130
1573979	Obsolete—contact Eaton	—	Time lag fuse unit	DBA-2	121	15
1573980	Obsolete—contact Eaton	—	Time lag fuse unit	DBA-2	121	20
1573981	Obsolete—contact Eaton	—	Time lag fuse unit	DBA-2	121	25
1573982	Obsolete—contact Eaton	—	Time lag fuse unit	DBA-2	121	30
1573983	Obsolete—contact Eaton	—	Time lag fuse unit	DBA-2	121	40
1573984	Obsolete—contact Eaton	—	Time lag fuse unit	DBA-2	121	50
1573985	Obsolete—contact Eaton	—	Time lag fuse unit	DBA-2	121	65
1573986	Obsolete—contact Eaton	—	Time lag fuse unit	DBA-2	121	80
1573987	Obsolete—contact Eaton	—	Time lag fuse unit	DBA-2	121	100
1573988	Obsolete—contact Eaton	—	Time lag fuse unit	DBA-2	121	125
1573989	Obsolete—contact Eaton	—	Time lag fuse unit	DBA-2	121	150
1573990	Obsolete—contact Eaton	—	Time lag fuse unit	DBA-2	121	200

Appendix 2—Superseded Style Number Index

Westinghouse 6/7 Digit Style Number	Eaton Catalog Number	Eaton 10 Digit Style Number	Description	Type	Voltage Rating kV Max.	Current Rating Amperes
1574576	Obsolete—contact Eaton	423D140A07	Mounting	BAL	5.5	—
1574577	Obsolete—contact Eaton	423D140A27	Mounting	BAL	5.5	—
1574578	Obsolete—contact Eaton	423D140A24	Mounting	BAL	2.75	—
1574579	Obsolete—contact Eaton	423D140A04	Mounting	BAL	2.75	—
1576468	2CLE-30E	310C095G10	CL fuse unit	CLE	2.75	30
	2CLE-30E	449D797G02	CL fuse unit	CLE	2.75	30
1576469	2CLE-40E	449D797G12	CL fuse unit	CLE	2.75	40
	2CLE-40E	676C546G01	CL fuse unit	CLE	2.75	40
1576470	5CLE-30E	310C095G20	CL fuse unit	CLE	5.5	30
	5CLE-30E	5981C29G05	CL fuse unit	CLE	5.5	30
1576471	5CLE-40E	5981C65G01	CL fuse unit	CLE	5.5	40
	5CLE-40E	676C546G14	CL fuse unit	CLE	5.5	40
1576472	8CLE-30E	5981C31G05	CL fuse unit	CLE	8.3	30
	8CLE-30E	677C573G01	CL fuse unit	CLE	8.3	30
1576473	8CLE-40E	5981C17G04	CL fuse unit	CLE	8.3	40
	8CLE-40E	677C573G02	CL fuse unit	CLE	8.3	40
1576474	15CLE-30E	439D378G03	CL fuse unit	CLE	15.5	30
	15CLE-30E	5981C33G05	CL fuse unit	CLE	15.5	30
1576475	15CLE-40E	439D378G04	CL fuse unit	CLE	15.5	40
	15CLE-40E	5981C19G04	CL fuse unit	CLE	15.5	40
1584339	Obsolete—contact Eaton	434D831A01	Mounting	DBA2/5	—	—
1585177	Obsolete—contact Eaton	423D770G05	Outdoor fuse holder vented	BA-400	8.3	—
1585178	Obsolete—contact Eaton	423D770G06	Outdoor fuse holder vented	BA-400	15.5	—
1585179	Obsolete—contact Eaton	423D770G07	Outdoor fuse holder vented	BA-400	25.5	—
1585180	Obsolete—contact Eaton	423D770G08	Outdoor fuse holder vented	BA-400	38	—
1585181	Obsolete—contact Eaton	423D770G09	Outdoor fuse holder vented	BA-400	8.3	—
1585182	Obsolete—contact Eaton	423D770G10	Outdoor fuse holder vented	BA-400	15.5	—
1585183	Obsolete—contact Eaton	423D770G11	Outdoor fuse holder vented	BA-400	25.5	—
1585184	Obsolete—contact Eaton	423D770G12	Outdoor fuse holder vented	BA-400	38	—
1585232	Obsolete—contact Eaton	—	Time lag fuse unit	DBA-2	96	15
1585233	Obsolete—contact Eaton	—	Time lag fuse unit	DBA-2	96	20
1585234	Obsolete—contact Eaton	—	Time lag fuse unit	DBA-2	96	25
1585235	Obsolete—contact Eaton	—	Time lag fuse unit	DBA-2	96	30
1585236	Obsolete—contact Eaton	—	Time lag fuse unit	DBA-2	96	40
1585237	Obsolete—contact Eaton	—	Time lag fuse unit	DBA-2	96	50
1585238	Obsolete—contact Eaton	—	Time lag fuse unit	DBA-2	96	65
1585239	Obsolete—contact Eaton	—	Time lag fuse unit	DBA-2	96	80
1585240	Obsolete—contact Eaton	—	Time lag fuse unit	DBA-2	96	100
1585241	Obsolete—contact Eaton	—	Time lag fuse unit	DBA-2	96	125
1585242	Obsolete—contact Eaton	—	Time lag fuse unit	DBA-2	96	150
1585243	Obsolete—contact Eaton	—	Time lag fuse unit	DBA-2	96	200
1585245	Obsolete—contact Eaton	—	Time lag fuse unit	DBA-2	145	15
1585246	Obsolete—contact Eaton	—	Time lag fuse unit	DBA-2	145	20
1585247	Obsolete—contact Eaton	—	Time lag fuse unit	DBA-2	145	25
1585248	Obsolete—contact Eaton	—	Time lag fuse unit	DBA-2	145	30
1585249	Obsolete—contact Eaton	—	Time lag fuse unit	DBA-2	145	40
1585250	Obsolete—contact Eaton	—	Time lag fuse unit	DBA-2	145	50
1585251	Obsolete—contact Eaton	—	Time lag fuse unit	DBA-2	145	65
1585252	Obsolete—contact Eaton	—	Time lag fuse unit	DBA-2	145	80
1585253	Obsolete—contact Eaton	—	Time lag fuse unit	DBA-2	145	100
1585254	Obsolete—contact Eaton	—	Time lag fuse unit	DBA-2	145	125
1585255	Obsolete—contact Eaton	—	Time lag fuse unit	DBA-2	145	150
1585256	Obsolete—contact Eaton	—	Time lag fuse unit	DBA-2	145	200

Appendix 2—Superseded Style Number Index

Westinghouse 6/7 Digit Style Number	Eaton Catalog Number	Eaton 10 Digit Style Number	Description	Type	Voltage Rating kV Max.	Current Rating Amperes
1585319	2NCLPT-2E	677C592G04	CL fuse unit	NCLE-PT	2.75	2
1585385	Obsolete—contact Eaton	117D122G05	Disconnect fuse holder	BA-200	8.3	—
1585386	Obsolete—contact Eaton	117D122G06	Disconnect fuse holder	BA-200	15.5	—
1585387	Obsolete—contact Eaton	117D122G07	Disconnect fuse holder	BA-200	25.5	—
1585388	Obsolete—contact Eaton	117D122G08	Disconnect fuse holder	BA-200	38	—
1585389	Obsolete—contact Eaton	117D122G01	Disconnect fuse holder	BA-200	8.3	—
1585390	Obsolete—contact Eaton	117D122G02	Disconnect fuse holder	BA-200	15.5	—
1585391	Obsolete—contact Eaton	117D122G03	Disconnect fuse holder	BA-200	25.5	—
1585392	Obsolete—contact Eaton	117D122G04	Disconnect fuse holder	BA-200	38	—
1585393	Obsolete—contact Eaton	676C880G01	Disconnect fuse holder	BA-400	8.3	—
1585394	Obsolete—contact Eaton	676C880G02	Disconnect fuse holder	BA-400	15.5	—
1585395	Obsolete—contact Eaton	676C880G03	Disconnect fuse holder	BA-400	25.5	—
1585396	Obsolete—contact Eaton	676C880G04	Disconnect fuse holder	BA-400	38	—
1585490	Obsolete—contact Eaton	505D616A02	Live parts	BA-200	—	—
1585492	5CLPT-1E	677C452G06	CL fuse unit	CLE-PT	5.5	1
1594922	RBA2-COND	310C197G03	Condenser (3 pack)	BA-200/RBA-200	—	—
1594923	RBA2-COND	310C197G03	Condenser (3 pack)	BA-200/RBA-200	—	—
1611883	Obsolete—contact Eaton	423D140A08	Mounting	BAL	5.5	—
1611884	Obsolete—contact Eaton	423D140A28	Mounting	BAL	5.5	—
1616388	RBA4-COND	310C197G04	Condenser (3 pack)	BA-400/RBA-400	—	—
1616389	RBA4-COND	310C197G04	Condenser (3 pack)	BA-400/RBA-400	—	—
1616747	Obsolete—contact Eaton	30A6178G01	Mounting	BA-800	—	—
1616748	Obsolete—contact Eaton	30A6178G02	Mounting	BA-800	—	—
1802143	Obsolete—contact Eaton	60A1307G01	Mounting	BA-800	—	—
1804417	Obsolete—contact Eaton	—	Time lag fuse unit	DBA-5	72	15
1804418	Obsolete—contact Eaton	—	Time lag fuse unit	DBA-5	72	20
1804419	Obsolete—contact Eaton	—	Time lag fuse unit	DBA-5	72	25
1804420	Obsolete—contact Eaton	—	Time lag fuse unit	DBA-5	72	30
1804421	Obsolete—contact Eaton	—	Time lag fuse unit	DBA-5	72	40
1804422	Obsolete—contact Eaton	—	Time lag fuse unit	DBA-5	72	50
1804423	Obsolete—contact Eaton	—	Time lag fuse unit	DBA-5	72	65
1804424	Obsolete—contact Eaton	—	Time lag fuse unit	DBA-5	72	80
1804425	Obsolete—contact Eaton	—	Time lag fuse unit	DBA-5	72	100
1804426	Obsolete—contact Eaton	—	Time lag fuse unit	DBA-5	72	125
1804427	Obsolete—contact Eaton	—	Time lag fuse unit	DBA-5	72	150
1804428	Obsolete—contact Eaton	—	Time lag fuse unit	DBA-5	72	200
1804429	Obsolete—contact Eaton	—	DBA5 fuse assembly	DBA-5	38.0	0.5
1804430	Obsolete—contact Eaton	—	DBA5 fuse assembly	DBA-5	38.0	3E
1804431	Obsolete—contact Eaton	—	DBA5 fuse assembly	DBA-5	38.0	5E
1804432	Obsolete—contact Eaton	—	DBA5 fuse assembly	DBA-5	38.0	7E
1804433	Obsolete—contact Eaton	—	DBA5 fuse assembly	DBA-5	38.0	10E
1804434	Obsolete—contact Eaton	—	DBA5 fuse assembly	DBA-5	38.0	15E
1804435	Obsolete—contact Eaton	—	DBA5 fuse assembly	DBA-5	38.0	20E
1804436	Obsolete—contact Eaton	—	DBA5 fuse assembly	DBA-5	38.0	25E
1804437	Obsolete—contact Eaton	—	DBA5 fuse assembly	DBA-5	38.0	30E
1804438	Obsolete—contact Eaton	—	DBA5 fuse assembly	DBA-5	38.0	40
1804439	Obsolete—contact Eaton	—	DBA5 fuse assembly	DBA-5	38.0	50
1804440	Obsolete—contact Eaton	—	DBA5 fuse assembly	DBA-5	38.0	65
1804441	Obsolete—contact Eaton	—	DBA5 fuse assembly	DBA-5	38.0	80
1804442	Obsolete—contact Eaton	—	DBA5 fuse assembly	DBA-5	38.0	100
1804443	Obsolete—contact Eaton	—	DBA5 fuse assembly	DBA-5	38.0	125
1804444	Obsolete—contact Eaton	—	DBA5 fuse assembly	DBA-5	38.0	150
1804445	Obsolete—contact Eaton	—	DBA5 fuse assembly	DBA-5	38.0	200

Appendix 2—Superseded Style Number Index

Westinghouse 6/7 Digit Style Number	Eaton Catalog Number	Eaton 10 Digit Style Number	Description	Type	Voltage Rating kV Max.	Current Rating Amperes
1804446	Obsolete—contact Eaton	—	DBA5 fuse assembly	DBA-5	48.3	0.5
1804447	Obsolete—contact Eaton	—	DBA5 fuse assembly	DBA-5	48.3	3E
1804448	Obsolete—contact Eaton	—	DBA5 fuse assembly	DBA-5	48.3	5E
1804449	Obsolete—contact Eaton	—	DBA5 fuse assembly	DBA-5	48.3	7E
1804450	Obsolete—contact Eaton	—	DBA5 fuse assembly	DBA-5	48.3	10E
1804451	Obsolete—contact Eaton	—	DBA5 fuse assembly	DBA-5	48.3	15E
1804452	Obsolete—contact Eaton	—	DBA5 fuse assembly	DBA-5	48.3	20E
1804453	Obsolete—contact Eaton	—	DBA5 fuse assembly	DBA-5	48.3	25E
1804454	Obsolete—contact Eaton	—	DBA5 fuse assembly	DBA-5	48.3	30E
1804455	Obsolete—contact Eaton	—	DBA5 fuse assembly	DBA-5	48.3	40
1804456	Obsolete—contact Eaton	—	DBA5 fuse assembly	DBA-5	48.3	50
1804457	Obsolete—contact Eaton	—	DBA5 fuse assembly	DBA-5	48.3	65
1804458	Obsolete—contact Eaton	—	DBA5 fuse assembly	DBA-5	48.3	80
1804459	Obsolete—contact Eaton	—	DBA5 fuse assembly	DBA-5	48.3	100
1804460	Obsolete—contact Eaton	—	DBA5 fuse assembly	DBA-5	48.3	125
1804461	Obsolete—contact Eaton	—	DBA5 fuse assembly	DBA-5	48.3	150
1804462	Obsolete—contact Eaton	—	DBA5 fuse assembly	DBA-5	48.3	200
1804463	Obsolete—contact Eaton	—	DBA5 fuse assembly	DBA-5	72.5	0.5
1804464	Obsolete—contact Eaton	—	DBA5 fuse assembly	DBA-5	72.5	3E
1804465	Obsolete—contact Eaton	—	DBA5 fuse assembly	DBA-5	72.5	5E
1804466	Obsolete—contact Eaton	—	DBA5 fuse assembly	DBA-5	72.5	7E
1804467	Obsolete—contact Eaton	—	DBA5 fuse assembly	DBA-5	72.5	10E
1804468	Obsolete—contact Eaton	—	DBA5 fuse assembly	DBA-5	72.5	15E
1804469	Obsolete—contact Eaton	—	DBA5 fuse assembly	DBA-5	72.5	20E
1804470	Obsolete—contact Eaton	—	DBA5 fuse assembly	DBA-5	72.5	25E
1804471	Obsolete—contact Eaton	—	DBA5 fuse assembly	DBA-5	72.5	30E
1804472	Obsolete—contact Eaton	—	DBA5 fuse assembly	DBA-5	72.5	40
1804473	Obsolete—contact Eaton	—	DBA5 fuse assembly	DBA-5	72.5	50
1804474	Obsolete—contact Eaton	—	DBA5 fuse assembly	DBA-5	72.5	65
1804475	Obsolete—contact Eaton	—	DBA5 fuse assembly	DBA-5	72.5	80
1804476	Obsolete—contact Eaton	—	DBA5 fuse assembly	DBA-5	72.5	100
1804477	Obsolete—contact Eaton	—	DBA5 fuse assembly	DBA-5	72.5	125
1804478	Obsolete—contact Eaton	—	DBA5 fuse assembly	DBA-5	72.5	150
1804479	Obsolete—contact Eaton	—	DBA5 fuse assembly	DBA-5	72.5	200
1804577	Obsolete—contact Eaton	—	Time lag fuse unit	DBA-5	38	15
1804578	Obsolete—contact Eaton	—	Time lag fuse unit	DBA-5	38	20
1804579	Obsolete—contact Eaton	—	Time lag fuse unit	DBA-5	38	25
1804580	Obsolete—contact Eaton	—	Time lag fuse unit	DBA-5	38	30
1804581	Obsolete—contact Eaton	—	Time lag fuse unit	DBA-5	38	40
1804582	Obsolete—contact Eaton	—	Time lag fuse unit	DBA-5	38	50
1804583	Obsolete—contact Eaton	—	Time lag fuse unit	DBA-5	38	65
1804584	Obsolete—contact Eaton	—	Time lag fuse unit	DBA-5	38	80
1804585	Obsolete—contact Eaton	—	Time lag fuse unit	DBA-5	38	100
1804586	Obsolete—contact Eaton	—	Time lag fuse unit	DBA-5	38	125
1804587	Obsolete—contact Eaton	—	Time lag fuse unit	DBA-5	38	150
1804588	Obsolete—contact Eaton	—	Time lag fuse unit	DBA-5	38	200
1804589	Obsolete—contact Eaton	—	Time lag fuse unit	DBA-5	48	15
1804590	Obsolete—contact Eaton	—	Time lag fuse unit	DBA-5	48	20
1804591	Obsolete—contact Eaton	—	Time lag fuse unit	DBA-5	48	25
1804592	Obsolete—contact Eaton	—	Time lag fuse unit	DBA-5	48	30
1804593	Obsolete—contact Eaton	—	Time lag fuse unit	DBA-5	48	40
1804594	Obsolete—contact Eaton	—	Time lag fuse unit	DBA-5	48	50
1804595	Obsolete—contact Eaton	—	Time lag fuse unit	DBA-5	48	65

Appendix 2—Superseded Style Number Index

Westinghouse 6/7 Digit Style Number	Eaton Catalog Number	Eaton 10 Digit Style Number	Description	Type	Voltage Rating kV Max.	Current Rating Amperes
1804596	Obsolete—contact Eaton	—	Time lag fuse unit	DBA-5	48	80
1804597	Obsolete—contact Eaton	—	Time lag fuse unit	DBA-5	48	100
1804598	Obsolete—contact Eaton	—	Time lag fuse unit	DBA-5	48	125
1804599	Obsolete—contact Eaton	—	Time lag fuse unit	DBA-5	48	150
1804600	Obsolete—contact Eaton	—	Time lag fuse unit	DBA-5	48	200
1804601	Obsolete—contact Eaton	—	Time lag fuse unit	DBA-2	38	15
1804602	Obsolete—contact Eaton	—	Time lag fuse unit	DBA-2	38	20
1804603	Obsolete—contact Eaton	—	Time lag fuse unit	DBA-2	38	25
1804604	Obsolete—contact Eaton	—	Time lag fuse unit	DBA-2	38	30
1804605	Obsolete—contact Eaton	—	Time lag fuse unit	DBA-2	38	40
1804606	Obsolete—contact Eaton	—	Time lag fuse unit	DBA-2	38	50
1804607	Obsolete—contact Eaton	—	Time lag fuse unit	DBA-2	38	65
1804608	Obsolete—contact Eaton	—	Time lag fuse unit	DBA-2	38	80
1804609	Obsolete—contact Eaton	—	Time lag fuse unit	DBA-2	38	100
1804610	Obsolete—contact Eaton	—	Time lag fuse unit	DBA-2	38	125
1804611	Obsolete—contact Eaton	—	Time lag fuse unit	DBA-2	38	150
1804612	Obsolete—contact Eaton	—	Time lag fuse unit	DBA-2	38	200
1804613	Obsolete—contact Eaton	—	Time lag fuse unit	DBA-2	48	15
1804614	Obsolete—contact Eaton	—	Time lag fuse unit	DBA-2	48	20
1804615	Obsolete—contact Eaton	—	Time lag fuse unit	DBA-2	48	25
1804616	Obsolete—contact Eaton	—	Time lag fuse unit	DBA-2	48	30
1804617	Obsolete—contact Eaton	—	Time lag fuse unit	DBA-2	48	40
1804618	Obsolete—contact Eaton	—	Time lag fuse unit	DBA-2	48	50
1804619	Obsolete—contact Eaton	—	Time lag fuse unit	DBA-2	48	65
1804620	Obsolete—contact Eaton	—	Time lag fuse unit	DBA-2	48	80
1804621	Obsolete—contact Eaton	—	Time lag fuse unit	DBA-2	48	100
1804622	Obsolete—contact Eaton	—	Time lag fuse unit	DBA-2	48	125
1804623	Obsolete—contact Eaton	—	Time lag fuse unit	DBA-2	48	150
1804624	Obsolete—contact Eaton	—	Time lag fuse unit	DBA-2	48	200
1804654	5LCLS-2R	676C546G15	CL fuse unit	CLS	5.5	70
1804655	5LCLS-4R	676C546G17	CL fuse unit	CLS	5.5	130
1804656	5LCLS-6R	676C546G19	CL fuse unit	CLS	5.5	170
1804657	5LCLS-9R	676C546G22	CL fuse unit	CLS	5.5	200
1804658	5LCLS-12R	676C546G25	CL fuse unit	CLS	5.5	230
1804760	Obsolete—contact Eaton	—	Time lag fuse unit	DBA-1	8.3	15
1804761	Obsolete—contact Eaton	—	Time lag fuse unit	DBA-1	8.3	20
1804762	Obsolete—contact Eaton	—	Time lag fuse unit	DBA-1	8.3	25
1804763	Obsolete—contact Eaton	—	Time lag fuse unit	DBA-1	8.3	30
1804764	Obsolete—contact Eaton	—	Time lag fuse unit	DBA-1	8.3	40
1804765	Obsolete—contact Eaton	—	Time lag fuse unit	DBA-1	8.3	50
1804766	Obsolete—contact Eaton	—	Time lag fuse unit	DBA-1	8.3	65
1804767	Obsolete—contact Eaton	—	Time lag fuse unit	DBA-1	8.3	80
1804768	Obsolete—contact Eaton	—	Time lag fuse unit	DBA-1	8.3	100
1804769	Obsolete—contact Eaton	—	Time lag fuse unit	DBA-1	8.3	125
1804770	Obsolete—contact Eaton	—	Time lag fuse unit	DBA-1	8.3	150
1804771	Obsolete—contact Eaton	—	Time lag fuse unit	DBA-1	8.3	200
1804772	Obsolete—contact Eaton	—	Time lag fuse unit	DBA-1	15.5	15
1804773	Obsolete—contact Eaton	—	Time lag fuse unit	DBA-1	15.5	20
1804774	Obsolete—contact Eaton	—	Time lag fuse unit	DBA-1	15.5	25
1804775	Obsolete—contact Eaton	—	Time lag fuse unit	DBA-1	15.5	30
1804776	Obsolete—contact Eaton	—	Time lag fuse unit	DBA-1	15.5	40
1804777	Obsolete—contact Eaton	—	Time lag fuse unit	DBA-1	15.5	50
1804778	Obsolete—contact Eaton	—	Time lag fuse unit	DBA-1	15.5	65

Appendix 2—Superseded Style Number Index

Westinghouse 6/7 Digit Style Number	Eaton Catalog Number	Eaton 10 Digit Style Number	Description	Type	Voltage Rating kV Max.	Current Rating Amperes
1804779	Obsolete—contact Eaton	—	Time lag fuse unit	DBA-1	15.5	80
1804780	Obsolete—contact Eaton	—	Time lag fuse unit	DBA-1	15.5	100
1804781	Obsolete—contact Eaton	—	Time lag fuse unit	DBA-1	15.5	125
1804782	Obsolete—contact Eaton	—	Time lag fuse unit	DBA-1	15.5	150
1804783	Obsolete—contact Eaton	—	Time lag fuse unit	DBA-1	15.5	200
1804784	Obsolete—contact Eaton	—	Time lag fuse unit	DBA-1	25.5	15
1804785	Obsolete—contact Eaton	—	Time lag fuse unit	DBA-1	25.5	20
1804786	Obsolete—contact Eaton	—	Time lag fuse unit	DBA-1	25.5	25
1804787	Obsolete—contact Eaton	—	Time lag fuse unit	DBA-1	25.5	30
1804788	Obsolete—contact Eaton	—	Time lag fuse unit	DBA-1	25.5	40
1804789	Obsolete—contact Eaton	—	Time lag fuse unit	DBA-1	25.5	50
1804790	Obsolete—contact Eaton	—	Time lag fuse unit	DBA-1	25.5	65
1804791	Obsolete—contact Eaton	—	Time lag fuse unit	DBA-1	25.5	80
1804792	Obsolete—contact Eaton	—	Time lag fuse unit	DBA-1	25.5	100
1804793	Obsolete—contact Eaton	—	Time lag fuse unit	DBA-1	25.5	125
1804794	Obsolete—contact Eaton	—	Time lag fuse unit	DBA-1	25.5	150
1804795	Obsolete—contact Eaton	—	Time lag fuse unit	DBA-1	25.5	200
1804796	Obsolete—contact Eaton	—	Time lag fuse unit	DBA-1	38	15
1804797	Obsolete—contact Eaton	—	Time lag fuse unit	DBA-1	38	20
1804798	Obsolete—contact Eaton	—	Time lag fuse unit	DBA-1	38	25
1804799	Obsolete—contact Eaton	—	Time lag fuse unit	DBA-1	38	30
1804800	Obsolete—contact Eaton	—	Time lag fuse unit	DBA-1	38	40
1804801	Obsolete—contact Eaton	—	Time lag fuse unit	DBA-1	38	50
1804802	Obsolete—contact Eaton	—	Time lag fuse unit	DBA-1	38	65
1804803	Obsolete—contact Eaton	—	Time lag fuse unit	DBA-1	38	80
1804804	Obsolete—contact Eaton	—	Time lag fuse unit	DBA-1	38	100
1804805	Obsolete—contact Eaton	—	Time lag fuse unit	DBA-1	38	125
1804806	Obsolete—contact Eaton	—	Time lag fuse unit	DBA-1	38	150
1804807	Obsolete—contact Eaton	—	Time lag fuse unit	DBA-1	38	200
1804808	Obsolete—contact Eaton	—	Time lag fuse unit	DBA-1	48	15
1804809	Obsolete—contact Eaton	—	Time lag fuse unit	DBA-1	48	20
1804810	Obsolete—contact Eaton	—	Time lag fuse unit	DBA-1	48	25
1804811	Obsolete—contact Eaton	—	Time lag fuse unit	DBA-1	48	30
1804812	Obsolete—contact Eaton	—	Time lag fuse unit	DBA-1	48	40
1804813	Obsolete—contact Eaton	—	Time lag fuse unit	DBA-1	48	50
1804814	Obsolete—contact Eaton	—	Time lag fuse unit	DBA-1	48	65
1804815	Obsolete—contact Eaton	—	Time lag fuse unit	DBA-1	48	80
1804816	Obsolete—contact Eaton	—	Time lag fuse unit	DBA-1	48	100
1804817	Obsolete—contact Eaton	—	Time lag fuse unit	DBA-1	48	125
1804818	Obsolete—contact Eaton	—	Time lag fuse unit	DBA-1	48	150
1804819	Obsolete—contact Eaton	—	Time lag fuse unit	DBA-1	48	200
1804820	Obsolete—contact Eaton	—	Time lag fuse unit	DBA-1	72	15
1804821	Obsolete—contact Eaton	—	Time lag fuse unit	DBA-1	72	20
1804822	Obsolete—contact Eaton	—	Time lag fuse unit	DBA-1	72	25
1804823	Obsolete—contact Eaton	—	Time lag fuse unit	DBA-1	72	30
1804824	Obsolete—contact Eaton	—	Time lag fuse unit	DBA-1	72	40
1804825	Obsolete—contact Eaton	—	Time lag fuse unit	DBA-1	72	50
1804826	Obsolete—contact Eaton	—	Time lag fuse unit	DBA-1	72	65
1804827	Obsolete—contact Eaton	—	Time lag fuse unit	DBA-1	72	80
1804828	Obsolete—contact Eaton	—	Time lag fuse unit	DBA-1	72	100
1804829	Obsolete—contact Eaton	—	Time lag fuse unit	DBA-1	72	125
1804830	Obsolete—contact Eaton	—	Time lag fuse unit	DBA-1	72	150
1804831	Obsolete—contact Eaton	—	Time lag fuse unit	DBA-1	72	200

Appendix 2—Superseded Style Number Index

Westinghouse 6/7 Digit Style Number	Eaton Catalog Number	Eaton 10 Digit Style Number	Description	Type	Voltage Rating kV Max.	Current Rating Amperes
1804860	2CLS-18R	591C813G01	CL fuse unit	CLS	2.54	390
1804861	2CLS-24R	591C813G02	CL fuse unit	CLS	2.54	450
1804862	5LCLS-18R	304C463G03	CL fuse unit	CLS	5.08	390
1804863	5LCLS-24R	304C463G04	CL fuse unit	CLS	5.08	450
1804880	Obsolete—contact Eaton	116D412A02	Mounting	BAL-LR	5.08	—
1804881	Obsolete—contact Eaton	116D412A09	Mounting	BAL-LR	8.3	—
1804882	Obsolete—contact Eaton	116D412A02	Mounting	BAL-LR	5.08	—
1804883	Obsolete—contact Eaton	116D412A09	Mounting	BAL-LR	8.3	—
1804884	Obsolete—contact Eaton	116D412A02	Mounting	BAL-LR	5.08	—
1804885	Obsolete—contact Eaton	116D412A09	Mounting	BAL-LR	8.3	—
1804886	Obsolete—contact Eaton	116D412A13	Mounting	BAL-LR	5.08	—
1804887	Obsolete—contact Eaton	116D412A19	Mounting	BAL-LR	8.3	—
1804888	Obsolete—contact Eaton	116D412A23	Mounting	BAL-LR	5.08	—
1804889	Obsolete—contact Eaton	116D412A29	Mounting	BAL-LR	8.3	—
1804890	Obsolete—contact Eaton	116D412A33	Mounting	BAL-LR	5.08	—
1804891	Obsolete—contact Eaton	116D412A39	Mounting	BAL-LR	8.3	—
1804892	Obsolete—contact Eaton	116D412A05	Mounting	BAL-LR	5.08	—
1804893	Obsolete—contact Eaton	116D412A05	Mounting	BAL-LR	5.08	—
1804894	Obsolete—contact Eaton	116D412A05	Mounting	BAL-LR	5.08	—
1804895	Obsolete—contact Eaton	116D412A15	Mounting	BAL-LR	5.08	—
1804896	Obsolete—contact Eaton	116D412A25	Mounting	BAL-LR	5.08	—
1804897	Obsolete—contact Eaton	116D412A35	Mounting	BAL-LR	5.08	—
1804898	Obsolete—contact Eaton	667C774G14	Live parts	BAL-LR	—	—
1804899	Obsolete—contact Eaton	667C774G14	Live parts	BAL-LR	—	—

Appendix 2—Superseded Style Number Index

10 Character Style Numbers

Old 10 Digit Style Number	Current Eaton Catalog Number	Eaton 10 Digit Style Number	Description	Type	Voltage Rating kV Max.	Current Rating Amperes
116D412A02	2CLE-PDM-E	9078A65G20	—	CLE	2.75	450
116D412A05	5CLE-PDM-E	9078A65G21	—	CLE	5.5	450
116D412A06	5CLE-PDM-E	9078A65G21	—	CLE	5.5	450
116D412A09	8CLE-PDM-E	9078A65G22	—	CLE	8.3	350
116D412A11	15CLE-PDM-E	9078A65G23	—	CLE	15.5	300
116D412A13	Obsolete—contact Eaton	—	2.4 kV top rear con. mounting	CLE	2.75	450
116D412A15	Obsolete—contact Eaton	—	4.8 kV top rear con. mounting	CLE	5.5	450
116D412A16	Obsolete—contact Eaton	—	4.8 kV top rear con. mounting	CLE	5.5	450
116D412A19	Obsolete—contact Eaton	—	7.2 kV top rear con. mounting	CLE	8.3	350
116D412A21	Obsolete—contact Eaton	—	14.4 kV top rear con. mounting	CLE	15.5	300
116D412A23	Obsolete—contact Eaton	—	2.4 kV double rear con. mounting	CLE	2.75	450
116D412A25	Obsolete—contact Eaton	—	4.8 kV double rear con. mounting	CLE	5.5	450
116D412A26	Obsolete—contact Eaton	—	4.8 kV double rear con. mounting	CLE	5.5	450
116D412A29	Obsolete—contact Eaton	—	7.2 kV double rear con. mounting	CLE	8.3	350
116D412A31	Obsolete—contact Eaton	—	14.4 kV double rear con. mounting	CLE	15.5	300
116D412A33	Obsolete—contact Eaton	—	2.4 kV bottom rear con. mounting	CLE	2.75	450
116D412A35	Obsolete—contact Eaton	—	4.8 kV bottom rear con. mounting	CLE	5.5	450
116D412A36	Obsolete—contact Eaton	—	4.8 kV bottom rear con. mounting	CLE	5.5	450
116D412A39	Obsolete—contact Eaton	—	7.2 kV bottom rear con. mounting	CLE	8.3	350
116D412A41	Obsolete—contact Eaton	—	14.4 kV bottom rear con. mounting	CLE	15.5	300
116D977A1	8BA4-.5E	116D977A1	—	BA4	8.3	0.5
116D977A2	8BA4-5E	116D977A2	—	BA4	8.3	5
116D977A3	8BA4-7E	116D977A3	—	BA4	8.3	7 E
116D977A4	8BA4-10E	116D977A4	—	BA4	8.3	10 E
116D977A5	8BA4-15E	116D977A5	—	BA4	8.3	15 E
116D977A6	8BA4-20E	116D977A6	—	BA4	8.3	20 E
116D977A7	8BA4-25E	116D977A7	—	BA4	8.3	25 E
116D977A8	8BA4-30E	116D977A8	—	BA4	8.3	30 E
116D977A9	8BA4-40E	116D977A9	—	BA4	8.3	40 E
116D977A10	8BA4-50E	116D977A10	—	BA4	8.3	50 E
116D977A11	8BA4-65E	116D977A11	—	BA4	8.3	65 E
116D977A12	8BA4-80E	116D977A12	—	BA4	8.3	80 E
116D977A13	8BA4-100E	116D977A13	—	BA4	8.3	100 E
116D977A14	8BA4-125E	116D977A14	—	BA4	8.3	125 E
116D977A15	8BA4-150E	116D977A15	—	BA4	8.3	150 E
116D977A16	8BA4-200E	116D977A16	—	BA4	8.3	200 E
116D977A17	8BA4-250E	116D977A17	—	BA4	8.3	250 E
116D977A18	8BA4-300E	116D977A18	—	BA4	8.3	300 E
116D977A19	8BA4-400E	116D977A19	—	BA4	8.3	400 E
116D977A21	15BA4-.5E	116D977A21	—	BA4	15.5	0.5
116D977A22	15BA4-5E	116D977A22	—	BA4	15.5	5
116D977A23	15BA4-7E	116D977A23	—	BA4	15.5	7 E
116D977A24	15BA4-10E	116D977A24	—	BA4	15.5	10 E
116D977A25	15BA4-15E	116D977A25	—	BA4	15.5	15 E
116D977A26	15BA4-20E	116D977A26	—	BA4	15.5	20 E
116D977A27	15BA4-25E	116D977A27	—	BA4	15.5	25 E
116D977A28	15BA4-30E	116D977A28	—	BA4	15.5	30 E
116D977A29	15BA4-40E	116D977A29	—	BA4	15.5	40 E
116D977A30	15BA4-50E	116D977A30	—	BA4	15.5	50 E
116D977A31	15BA4-65E	116D977A31	—	BA4	15.5	65 E

Appendix 2—Superseded Style Number Index

Old 10 Digit Style Number	Current Eaton Catalog Number	Eaton 10 Digit Style Number	Description	Type	Voltage Rating kV Max.	Current Rating Amperes
116D977A32	15BA4-80E	116D977A32	—	BA4	15.5	80 E
116D977A33	15BA4-100E	116D977A33	—	BA4	15.5	100 E
116D977A34	15BA4-125E	116D977A34	—	BA4	15.5	125 E
116D977A35	15BA4-150E	116D977A35	—	BA4	15.5	150 E
116D977A36	15BA4-200E	116D977A36	—	BA4	15.5	200 E
116D977A37	15BA4-250E	116D977A37	—	BA4	15.5	250 E
116D977A48	15BA4-300E	116D977A48	—	BA4	15.5	300 E
116D977A39	15BA4-400E	116D977A39	—	BA4	15.5	400 E
116D977A41	25BA4-.5E	116D977A41	—	BA4	25	0.5
116D977A42	25BA4-5E	116D977A42	—	BA4	25	5
116D977A43	25BA4-7E	116D977A43	—	BA4	25	7 E
116D977A44	25BA4-10E	116D977A44	—	BA4	25	10 E
116D977A45	25BA4-15E	116D977A45	—	BA4	25	15 E
116D977A46	25BA4-20E	116D977A46	—	BA4	25	20 E
116D977A47	25BA4-25E	116D977A47	—	BA4	25	25 E
116D977A48	25BA4-30E	116D977A48	—	BA4	25	30 E
116D977A49	25BA4-40E	116D977A49	—	BA4	25	40 E
116D977A50	25BA4-50E	116D977A50	—	BA4	25	50 E
116D977A51	25BA4-65E	116D977A51	—	BA4	25	65 E
116D977A52	25BA4-80E	116D977A52	—	BA4	25	80 E
116D977A53	25BA4-100E	116D977A53	—	BA4	25	100 E
116D977A54	25BA4-125E	116D977A54	—	BA4	25	125 E
116D977A55	25BA4-150E	116D977A55	—	BA4	25	150 E
116D977A56	25BA4-200E	116D977A56	—	BA4	25	200 E
116D977A57	25BA4-250E	116D977A57	—	BA4	25	250 E
116D977A58	25BA4-300E	116D977A58	—	BA4	25	300 E
116D977A61	38BA4-.5E	116D977A61	—	BA4	38	0.5
116D977A62	38BA4-5E	116D977A62	—	BA4	38	5
116D977A63	38BA4-7E	116D977A63	—	BA4	38	7 E
116D977A64	38BA4-10E	116D977A64	—	BA4	38	10 E
116D977A65	38BA4-15E	116D977A65	—	BA4	38	15 E
116D977A66	38BA4-20E	116D977A66	—	BA4	38	20 E
116D977A67	38BA4-25E	116D977A67	—	BA4	38	25 E
116D977A68	38BA4-30E	116D977A68	—	BA4	38	30 E
116D977A69	38BA4-40E	116D977A69	—	BA4	38	40 E
116D977A70	38BA4-50E	116D977A70	—	BA4	38	50 E
116D977A71	38BA4-65E	116D977A71	—	BA4	38	65 E
116D977A72	38BA4-80E	116D977A72	—	BA4	38	80 E
116D977A73	38BA4-100E	116D977A73	—	BA4	38	100 E
116D977A74	38BA4-125E	116D977A74	—	BA4	38	125 E
116D977A75	38BA4-150E	116D977A75	—	BA4	38	150 E
116D977A76	38BA4-200E	116D977A76	—	BA4	38	200 E
116D977A77	38BA4-250E	116D977A77	—	BA4	38	250 E
116D977A78	38BA4-300E	116D977A78	—	BA4	38	300 E
117D122G01	Obsolete—contact Eaton	—	Obsolete BA2 disconnect fuse holders	—	—	—
117D122G02	Obsolete—contact Eaton	—	Obsolete BA2 disconnect fuse holders	—	—	—
117D122G03	Obsolete—contact Eaton	—	Obsolete BA2 disconnect fuse holders	—	—	—
117D122G04	Obsolete—contact Eaton	—	Obsolete BA2 disconnect fuse holders	—	—	—
117D122G05	Obsolete—contact Eaton	—	Obsolete BA2 disconnect fuse holders	—	—	—
117D122G06	Obsolete—contact Eaton	—	Obsolete BA2 disconnect fuse holders	—	—	—
117D122G07	Obsolete—contact Eaton	—	Obsolete BA2 disconnect fuse holders	—	—	—
117D122G08	Obsolete—contact Eaton	—	Obsolete BA2 disconnect fuse holders	—	—	—
117D123A01	8BA2-.5E	117D123A01	—	BA2	8.3	0.5

Appendix 2—Superseded Style Number Index

Old 10 Digit Style Number	Current Eaton Catalog Number	Eaton 10 Digit Style Number	Description	Type	Voltage Rating kV Max.	Current Rating Amperes
117D123A02	8BA2-5E	117D123A02	—	BA2	8.3	5
117D123A03	8BA2-7E	117D123A03	—	BA2	8.3	7 E
117D123A04	8BA2-10E	117D123A04	—	BA2	8.3	10 E
117D123A05	8BA2-15E	117D123A05	—	BA2	8.3	15 E
117D123A06	8BA2-20E	117D123A06	—	BA2	8.3	20 E
117D123A07	8BA2-25E	117D123A07	—	BA2	8.3	25 E
117D123A08	8BA2-30E	117D123A08	—	BA2	8.3	30 E
117D123A09	8BA2-40E	117D123A09	—	BA2	8.3	40 E
117D123A10	8BA2-50E	117D123A10	—	BA2	8.3	50 E
117D123A11	8BA2-65E	117D123A11	—	BA2	8.3	65 E
117D123A12	8BA2-80E	117D123A12	—	BA2	8.3	80 E
117D123A13	8BA2-100E	117D123A13	—	BA2	8.3	100 E
117D123A14	8BA2-125E	117D123A14	—	BA2	8.3	125 E
117D123A15	8BA2-150E	117D123A15	—	BA2	8.3	150 E
117D123A16	8BA2-200E	117D123A16	—	BA2	8.3	200 E
117D123A17	15BA2-.5E	117D123A17	—	BA2	15.5	0.5
117D123A18	15BA2-5E	117D123A18	—	BA2	15.5	5
117D123A19	15BA2-7E	117D123A19	—	BA2	15.5	7 E
117D123A20	15BA2-10E	117D123A20	—	BA2	15.5	10 E
117D123A21	15BA2-15E	117D123A21	—	BA2	15.5	15 E
117D123A22	15BA2-20E	117D123A22	—	BA2	15.5	20 E
117D123A23	15BA2-25E	117D123A23	—	BA2	15.5	25 E
117D123A24	15BA2-30E	117D123A24	—	BA2	15.5	30 E
117D123A25	15BA2-40E	117D123A25	—	BA2	15.5	40 E
117D123A26	15BA2-50E	117D123A26	—	BA2	15.5	50 E
117D123A27	15BA2-65E	117D123A27	—	BA2	15.5	65 E
117D123A28	15BA2-80E	117D123A28	—	BA2	15.5	80 E
117D123A29	15BA2-100E	117D123A29	—	BA2	15.5	100 E
117D123A30	15BA2-125E	117D123A30	—	BA2	15.5	125 E
117D123A31	15BA2-150E	117D123A31	—	BA2	15.5	150 E
117D123A32	15BA2-200E	117D123A32	—	BA2	15.5	200 E
117D123A33	25BA2-.5E	117D123A33	—	BA2	25	0.5
117D123A34	25BA2-5E	117D123A34	—	BA2	25	5
117D123A35	25BA2-7E	117D123A35	—	BA2	25	7 E
117D123A36	25BA2-10E	117D123A36	—	BA2	25	10 E
117D123A37	25BA2-15E	117D123A37	—	BA2	25	15 E
117D123A48	25BA2-20E	117D123A48	—	BA2	25	20 E
117D123A39	25BA2-25E	117D123A39	—	BA2	25	25 E
117D123A40	25BA2-30E	117D123A40	—	BA2	25	30 E
117D123A41	25BA2-40E	117D123A41	—	BA2	25	40 E
117D123A42	25BA2-50E	117D123A42	—	BA2	25	50 E
117D123A43	25BA2-65E	117D123A43	—	BA2	25	65 E
117D123A44	25BA2-80E	117D123A44	—	BA2	25	80 E
117D123A45	25BA2-100E	117D123A45	—	BA2	25	100 E
117D123A46	25BA2-125E	117D123A46	—	BA2	25	125 E
117D123A47	25BA2-150E	117D123A47	—	BA2	25	150 E
117D123A48	25BA2-200E	117D123A48	—	BA2	25	200 E
117D123A49	38BA2-.5E	117D123A49	—	BA2	38	0.5
117D123A50	38BA2-5E	117D123A50	—	BA2	38	5
117D123A51	38BA2-7E	117D123A51	—	BA2	38	7 E
117D123A52	38BA2-10E	117D123A52	—	BA2	38	10 E
117D123A53	38BA2-15E	117D123A53	—	BA2	38	15 E
117D123A54	38BA2-20E	117D123A54	—	BA2	38	20 E

Appendix 2—Superseded Style Number Index

Old 10 Digit Style Number	Current Eaton Catalog Number	Eaton 10 Digit Style Number	Description	Type	Voltage Rating kV Max.	Current Rating Amperes
117D123A55	38BA2-25E	117D123A55	—	BA2	38	25 E
117D123A56	38BA2-30E	117D123A56	—	BA2	38	30 E
117D123A57	38BA2-40E	117D123A57	—	BA2	38	40 E
117D123A58	38BA2-50E	117D123A58	—	BA2	38	50 E
117D123A59	38BA2-65E	117D123A59	—	BA2	38	65 E
117D123A60	38BA2-80E	117D123A60	—	BA2	38	80 E
117D123A61	38BA2-100E	117D123A61	—	BA2	38	100 E
117D123A62	38BA2-125E	117D123A62	—	BA2	38	125 E
117D123A63	38BA2-150E	117D123A63	—	BA2	38	150 E
117D123A64	38BA2-200E	117D123A64	—	BA2	38	200 E
11A8127G02	72DBA2-5E	11A8127G02	—	DBA-2	72	5
11A8127G03	72DBA2-7E	11A8127G03	—	DBA-2	72	7 E
11A8127G04	72DBA2-10E	11A8127G04	—	DBA-2	72	10 E
11A8127G05	72DBA2-15E	11A8127G05	—	DBA-2	72	15 E
11A8127G06	72DBA2-20E	11A8127G06	—	DBA-2	72	20 E
11A8127G07	72DBA2-25E	11A8127G07	—	DBA-2	72	25 E
11A8127G08	72DBA2-30E	11A8127G08	—	DBA-2	72	30 E
11A8127G09	72DBA2-40E	11A8127G09	—	DBA-2	72	40 E
11A8127G10	72DBA2-50E	11A8127G10	—	DBA-2	72	50 E
11A8127G11	72DBA2-65E	11A8127G11	—	DBA-2	72	65 E
11A8127G12	72DBA2-80E	11A8127G12	—	DBA-2	72	80 E
11A8127G13	72DBA2-100E	11A8127G13	—	DBA-2	72	100 E
11A8127G14	72DBA2-125E	11A8127G14	—	DBA-2	72	125 E
11A8127G15	72DBA2-150E	11A8127G15	—	DBA-2	72	150 E
11A8127G16	72DBA2-200E	11A8127G16	—	DBA-2	72	200 E
11A8127G21	92DBA2-3E	11A8127G21	—	DBA-2	92	3
11A8127G22	92DBA2-5E	11A8127G22	—	DBA-2	92	5
11A8127G23	92DBA2-7E	11A8127G23	—	DBA-2	92	7 E
11A8127G24	92DBA2-10E	11A8127G24	—	DBA-2	92	10 E
11A8127G25	92DBA2-15E	11A8127G25	—	DBA-2	92	15 E
11A8127G26	92DBA2-20E	11A8127G26	—	DBA-2	92	20 E
11A8127G27	92DBA2-25E	11A8127G27	—	DBA-2	92	25 E
11A8127G28	92DBA2-30E	11A8127G28	—	DBA-2	92	30 E
11A8127G29	92DBA2-40E	11A8127G29	—	DBA-2	92	40 E
11A8127G30	92DBA2-50E	11A8127G30	—	DBA-2	92	50 E
11A8127G31	92DBA2-65E	11A8127G31	—	DBA-2	92	65 E
11A8127G32	92DBA2-80E	11A8127G32	—	DBA-2	92	80 E
11A8127G33	92DBA2-100E	11A8127G33	—	DBA-2	92	100 E
11A8127G34	92DBA2-125E	11A8127G34	—	DBA-2	92	125 E
11A8127G35	92DBA2-150E	11A8127G35	—	DBA-2	92	150 E
11A8127G36	92DBA2-200E	11A8127G36	—	DBA-2	92	200 E
11A8127G41	121DBA2-3E	11A8127G41	—	DBA-2	121	3
11A8127G42	121DBA2-5E	11A8127G42	—	DBA-2	121	5
11A8127G43	121DBA2-7E	11A8127G43	—	DBA-2	121	7 E
11A8127G44	121DBA2-10E	11A8127G44	—	DBA-2	121	10 E
11A8127G45	121DBA2-15E	11A8127G45	—	DBA-2	121	15 E
11A8127G46	121DBA2-20E	11A8127G46	—	DBA-2	121	20 E
11A8127G47	121DBA2-25E	11A8127G47	—	DBA-2	121	25 E
11A8127G48	121DBA2-30E	11A8127G48	—	DBA-2	121	30 E
11A8127G49	121DBA2-40E	11A8127G49	—	DBA-2	121	40 E
11A8127G50	121DBA2-50E	11A8127G50	—	DBA-2	121	50 E
11A8127G51	121DBA2-65E	11A8127G51	—	DBA-2	121	65 E
11A8127G52	121DBA2-80E	11A8127G52	—	DBA-2	121	80 E

Appendix 2—Superseded Style Number Index

Old 10 Digit Style Number	Current Eaton Catalog Number	Eaton 10 Digit Style Number	Description	Type	Voltage Rating kV Max.	Current Rating Amperes
11A8127G53	121DBA2-100E	11A8127G53	—	DBA-2	121	100 E
11A8127G54	121DBA2-125E	11A8127G54	—	DBA-2	121	125 E
11A8127G55	121DBA2-150E	11A8127G55	—	DBA-2	121	150 E
11A8127G56	121DBA2-200E	11A8127G56	—	DBA-2	121	200 E
11A8127G61	145DBA2-3E	11A8127G61	—	DBA-2	145	3
11A8127G62	145DBA2-5E	11A8127G62	—	DBA-2	145	5
11A8127G63	145DBA2-7E	11A8127G63	—	DBA-2	145	7 E
11A8127G64	145DBA2-10E	11A8127G64	—	DBA-2	145	10 E
11A8127G65	145DBA2-15E	11A8127G65	—	DBA-2	145	15 E
11A8127G66	145DBA2-20E	11A8127G66	—	DBA-2	145	20 E
11A8127G67	145DBA2-25E	11A8127G67	—	DBA-2	145	25 E
11A8127G68	145DBA2-30E	11A8127G68	—	DBA-2	145	30 E
11A8127G69	145DBA2-40E	11A8127G69	—	DBA-2	145	40 E
11A8127G70	145DBA2-50E	11A8127G70	—	DBA-2	145	50 E
11A8127G71	145DBA2-65E	11A8127G71	—	DBA-2	145	65 E
11A8127G72	145DBA2-80E	11A8127G72	—	DBA-2	145	80 E
11A8127G73	145DBA2-100E	11A8127G73	—	DBA-2	145	100 E
11A8127G74	145DBA2-125E	11A8127G74	—	DBA-2	145	125 E
11A8127G75	145DBA2-150E	11A8127G75	—	DBA-2	145	150 E
11A8127G76	145DBA2-200E	11A8127G76	—	DBA-2	145	200 E
11A8128G08	Obsolete—contact Eaton	—	DBA-2 end fittings	—	—	—
129D686G01	5ACLS-24R	151D933G04	—	CLS	5.08	24R(450)
129D686G02	5ACLS-18R	151D933G03	—	CLS	5.08	18R(390)
129D696G01	5ACLS-30	449D597G01	—	CLS	5.08	30
129D696G02	5ACLS-2R	449D597G02	—	CLS	5.08	2R(70)
129D696G03	5ACLS-3R	449D597G03	—	CLS	5.08	3R(1100)
129D696G04	5ACLS-4R	449D597G04	—	CLS	5.08	4R(130)
129D696G05	5ACLS-5R	449D597G05	—	CLS	5.08	5R(150)
129D696G06	5ACLS-6R	449D597G06	—	CLS	5.08	6R(170)
129D696G07	5ACLS-9R	151D933G01	—	CLS	5.08	9R(200)
129D696G08	5ACLS-12R	151D933G02	—	CLS	5.08	12R(230)
12A4519G03	CLE-DF-E	9078A63G04	—	CLE	—	450
13C8904G01	Obsolete—contact Eaton	—	Low voltage BAL fuses	—	—	—
13C8904G02	Obsolete—contact Eaton	—	Low voltage BAL fuses	—	—	—
13C8904G03	Obsolete—contact Eaton	—	Low voltage BAL fuses	—	—	—
13C8904G04	Obsolete—contact Eaton	—	Low voltage BAL fuses	—	—	—
13C8904G05	Obsolete—contact Eaton	—	Low voltage BAL fuses	—	—	—
140D045G01	5CLS70-32R	140D045G01	—	CLS	5.08	32R(600)
140D045G02	5CLS70-36R	140D045G02	—	CLS	5.08	36R(650)
140D045G03	5CLS70-24R	140D045G03	—	CLS	5.08	24R(450)
140D045G04	5CLS70-12R	140D045G04	—	CLS	5.08	12R(230)
140D045G05	5CLS70-44R	140D045G05	—	CLS	5.08	44R(700)
140D045G06	5CLS70-18R	140D045G06	—	CLS	5.08	18R(390)
140D144G01	Obsolete—contact Eaton	—	RBA-200 conversion kit	—	—	—
140D144G02	Obsolete—contact Eaton	—	RBA-200 conversion kit	—	—	—
140D144G03	Obsolete—contact Eaton	—	RBA-200 conversion kit	—	—	—
140D144G04	Obsolete—contact Eaton	—	RBA-200 conversion kit	—	—	—
140D144G05	Obsolete—contact Eaton	—	RBA-200 conversion kit	—	—	—
140D144G06	Obsolete—contact Eaton	—	RBA-200 conversion kit	—	—	—
140D144G07	Obsolete—contact Eaton	—	RBA-200 conversion kit	—	—	—
140D144G08	Obsolete—contact Eaton	—	RBA-200 conversion kit	—	—	—
140D144G09	Obsolete—contact Eaton	—	RBA-400 conversion kit	—	—	—
140D144G10	Obsolete—contact Eaton	—	RBA-400 conversion kit	—	—	—

Appendix 2—Superseded Style Number Index

Old 10 Digit Style Number	Current Eaton Catalog Number	Eaton 10 Digit Style Number	Description	Type	Voltage Rating kV Max.	Current Rating Amperes
140D144G11	Obsolete—contact Eaton	—	RBA-400 conversion kit	—	—	—
140D144G12	Obsolete—contact Eaton	—	RBA-400 conversion kit	—	—	—
140D144G13	Obsolete—contact Eaton	—	RBA-400 conversion kit	—	—	—
140D144G14	Obsolete—contact Eaton	—	RBA-400 conversion kit	—	—	—
140D144G15	Obsolete—contact Eaton	—	RBA-400 conversion kit	—	—	—
140D144G16	Obsolete—contact Eaton	—	RBA-400 conversion kit	—	—	—
140D180G01	Obsolete—contact Eaton	—	Sealed 5LCLS-24R	—	—	—
140D181G02	Obsolete—contact Eaton	—	Sealed 5LCLS-18R	—	—	—
140D309A01	RDB2-VL	140D309A01	—	RDB2	—	200
140D309G01	Obsolete—contact Eaton	—	8RDB2-VM—obsolete cap and pin insulators	—	—	—
140D309G02	Obsolete—contact Eaton	—	15RDB2-VM—obsolete cap and pin insulators	—	—	—
140D309G03	Obsolete—contact Eaton	—	25RDB2-VM—obsolete cap and pin insulators	—	—	—
140D309G04	Obsolete—contact Eaton	—	38RDB2-VM—obsolete cap and pin insulators	—	—	—
140D309G05	Obsolete—contact Eaton	—	8RDB2-HVM—obsolete cap and pin insulators	—	—	—
140D309G06	Obsolete—contact Eaton	—	15RDB2-HVM—obsolete cap and pin insulators	—	—	—
140D309G07	Obsolete—contact Eaton	—	25RDB2-HVM—obsolete cap and pin insulators	—	—	—
140D309G08	Obsolete—contact Eaton	—	38RDB2-HVM—obsolete cap and pin insulators	—	—	—
140D309G09	8RDB2-VM	140D309G09	Station post insulators	RDB2	8.3	200
140D309G10	15RDB2-VM	140D309G10	Station post insulators	RDB2	15.5	200
140D309G11	25RDB2-VM	140D309G11	Station post insulators	RDB2	25	200
140D309G12	38RDB2-VM	140D309G12	Station post insulators	RDB2	38	200
140D309G13	8RDB2-HVM	140D309G13	Station post insulators	RDB2	8.3	200
140D309G14	15RDB2-HVM	140D309G14	Station post insulators	RDB2	15.5	200
140D309G15	25RDB2-HVM	140D309G15	Station post insulators	RDB2	25	200
140D309G16	38RDB2-HVM	140D309G16	Station post insulators	RDB2	38	200
140D310A01	RDB4-VL	140D310A01	—	RDB4	—	400
140D310G01	Obsolete—contact Eaton	—	8RDB4-VM—obsolete cap and pin insulators	—	—	—
140D310G02	Obsolete—contact Eaton	—	15RDB4-VM—obsolete cap and pin insulators	—	—	—
140D310G03	Obsolete—contact Eaton	—	25RDB4-VM—obsolete cap and pin insulators	—	—	—
140D310G04	Obsolete—contact Eaton	—	38RDB4-VM—obsolete cap and pin insulators	—	—	—
140D310G05	Obsolete—contact Eaton	—	8RDB4-HVM—obsolete cap and pin insulators	—	—	—
140D310G06	Obsolete—contact Eaton	—	15RDB4-HVM—obsolete cap and pin insulators	—	—	—
140D310G07	Obsolete—contact Eaton	—	25RDB4-HVM—obsolete cap and pin insulators	—	—	—
140D310G08	Obsolete—contact Eaton	—	38RDB4-HVM—obsolete cap and pin insulators	—	—	—
140D310G09	8RDB4-VM	140D310G09	Station post insulators	RDB4	8.3	400
140D310G10	15RDB4-VM	140D310G10	Station post insulators	RDB4	15.5	400
140D310G11	25RDB4-VM	140D310G11	Station post insulators	RDB4	25	300
140D310G12	38RDB4-VM	140D310G12	Station post insulators	RDB4	38	300
140D310G13	8RDB4-HVM	140D310G13	Station post insulators	RDB4	8.3	400
140D310G14	15RDB4-HVM	140D310G14	Station post insulators	RDB4	15.5	400
140D310G15	25RDB4-HVM	140D310G15	Station post insulators	RDB4	25	300
140D310G16	38RDB4-HVM	140D310G16	Station post insulators	RDB4	38	300
140D311A01	RDB8-VL	140D311A01	—	RDB8	—	720
140D311G01	Obsolete—contact Eaton	—	8RDB8-VM—obsolete cap and pin insulators	—	—	—
140D311G02	Obsolete—contact Eaton	—	15RDB8-VM—obsolete cap and pin insulators	—	—	—
140D311G03	Obsolete—contact Eaton	—	25RDB8-VM—obsolete cap and pin insulators	—	—	—
140D311G04	Obsolete—contact Eaton	—	38RDB8-VM—obsolete cap and pin insulators	—	—	—
140D311G05	Obsolete—contact Eaton	—	8RDB8-HVM—obsolete cap and pin insulators	—	—	—
140D311G06	Obsolete—contact Eaton	—	15RDB8-HVM—obsolete cap and pin insulators	—	—	—
140D311G07	Obsolete—contact Eaton	—	25RDB8-HVM—obsolete cap and pin insulators	—	—	—
140D311G08	Obsolete—contact Eaton	—	38RDB8-HVM—obsolete cap and pin insulators	—	—	—
140D311G09	8RDB8-VM	140D311G09	Station post insulators	RDB8	8.3	720
140D311G10	15RDB8-VM	140D311G10	Station post insulators	RDB8	15.5	720

Appendix 2—Superseded Style Number Index

Old 10 Digit Style Number	Current Eaton Catalog Number	Eaton 10 Digit Style Number	Description	Type	Voltage Rating kV Max.	Current Rating Amperes
140D311G11	25RDB8-VM	140D311G11	Station post insulators	RDB8	25	540
140D311G12	38RDB8-VM	140D311G12	Station post insulators	RDB8	38	540
140D311G13	8RDB8-HVM	140D311G13	Station post insulators	RDB8	8.3	720
140D311G14	15RDB8-HVM	140D311G14	Station post insulators	RDB8	15.5	720
140D311G15	25RDB8-HVM	140D311G15	Station post insulators	RDB8	25	540
140D311G16	38RDB8-HVM	140D311G16	Station post insulators	RDB8	38	540
140D316G01	6DSL-A150	140D316G01	—	DSL	0.6	160
140D316G02	6DSL-A250	140D316G02	—	DSL	0.6	200
140D316G03	6DSL-A300	140D316G03	—	DSL	0.6	300
140D316G04	6DSL-A400	140D316G04	—	DSL	0.6	400
140D316G05	6DSL-A500	140D316G05	—	DSL	0.6	500
140D316G06	6DSL-A600	140D316G06	—	DSL	0.6	600
140D316G07	6DSL-A800	140D316G07	—	DSL	0.6	800
140D316G10	6DSL-B1200	140D316G10	—	DSL	0.6	1200
140D316G11	6DSL-B1600	140D316G11	—	DSL	0.6	1600
140D316G12	6DSL-B2000	140D316G12	—	DSL	0.6	2000
140D316G15	6DSL-C800	151D932G01	—	DSL	0.6	800
140D316G16	6DSL-C1000	151D932G02	—	DSL	0.6	1000
140D316G17	6DSL-C1200	151D932G03	—	DSL	0.6	1200
140D316G18	6DSL-C1600	151D932G04	—	DSL	0.6	1600
140D316G19	6DSL-C2000	151D932G05	—	DSL	0.6	2000
140D316G21	6DSL-D2500	151D932G09	—	DSL	0.6	2500
140D316G22	6DSL-D3000	151D932G10	—	DSL	0.6	3000
140D318G01	4NPL-1875	140D318G01	—	NPL	0.48	1875
140D318G02	4NPL-2825	140D318G02	—	NPL	0.48	2825
140D318G04	4NPL-900	140D318G04	—	NPL	0.48	900
140D318G05	4NPL-1300	140D318G05	—	NPL	0.48	1300
140D318G06	4NPL-3000	140D318G06	—	NPL	0.48	3000
140D318G07	4NPL-2000	140D318G07	—	NPL	0.48	2000
140D318G08	4NPL-3500	140D318G08	—	NPL	0.48	3500
140D331G02	Obsolete—contact Eaton	—	2.4/4.8 kV RBA2 loadbreak mounting back connected	—	—	—
140D331G03	Obsolete—contact Eaton	—	2.4/4.8 kV RBA2 loadbreak mounting back connected	—	—	—
140D331G04	Obsolete—contact Eaton	—	2.4/4.8 kV RBA2 loadbreak mounting back connected	—	—	—
140D331G06	Obsolete—contact Eaton	—	7.2 kV RBA2 loadbreak mounting back connected	—	—	—
140D331G07	Obsolete—contact Eaton	—	7.2 kV RBA2 loadbreak mounting back connected	—	—	—
140D331G08	Obsolete—contact Eaton	—	7.2 kV RBA2 loadbreak mounting back connected	—	—	—
140D331G10	Obsolete—contact Eaton	—	13.8 kV RBA2 loadbreak mounting back connected	—	—	—
140D331G11	Obsolete—contact Eaton	—	13.8 kV RBA2 loadbreak mounting back connected	—	—	—
140D331G12	Obsolete—contact Eaton	—	13.8 kV RBA2 loadbreak mounting back connected	—	—	—
140D331G14	Obsolete—contact Eaton	—	14.4 kV RBA2 loadbreak mounting back connected	—	—	—
140D331G15	Obsolete—contact Eaton	—	14.4 kV RBA2 loadbreak mounting back connected	—	—	—
140D331G16	Obsolete—contact Eaton	—	14.4 kV RBA2 loadbreak mounting back connected	—	—	—
140D332G02	Obsolete—contact Eaton	—	2.4/4.8 kV RBA4 loadbreak mounting back connected	—	—	—
140D332G03	Obsolete—contact Eaton	—	2.4/4.8 kV RBA4 loadbreak mounting back connected	—	—	—
140D332G04	Obsolete—contact Eaton	—	2.4/4.8 kV RBA4 loadbreak mounting back connected	—	—	—
140D332G06	Obsolete—contact Eaton	—	7.2 kV RBA4 loadbreak mounting back connected	—	—	—
140D332G07	Obsolete—contact Eaton	—	7.2 kV RBA4 loadbreak mounting back connected	—	—	—
140D332G08	Obsolete—contact Eaton	—	7.2 kV RBA4 loadbreak mounting back connected	—	—	—
140D332G10	Obsolete—contact Eaton	—	13.8 kV RBA4 loadbreak mounting back connected	—	—	—
140D332G11	Obsolete—contact Eaton	—	13.8 kV RBA4 loadbreak mounting back connected	—	—	—
140D332G12	Obsolete—contact Eaton	—	13.8 kV RBA4 loadbreak mounting back connected	—	—	—
140D332G14	Obsolete—contact Eaton	—	14.4 kV RBA4 loadbreak mounting back connected	—	—	—
140D332G15	Obsolete—contact Eaton	—	14.4 kV RBA4 loadbreak mounting back connected	—	—	—

Appendix 2—Superseded Style Number Index

Old 10 Digit Style Number	Current Eaton Catalog Number	Eaton 10 Digit Style Number	Description	Type	Voltage Rating kV Max.	Current Rating Amperes
140D332G16	Obsolete—contact Eaton	—	14.4 kV RBA4 loadbreak mounting back connected	—	—	—
140D332G18	Obsolete—contact Eaton	—	23 kV RBA4 loadbreak mounting back connected	—	—	—
140D332G19	Obsolete—contact Eaton	—	24 kV RBA4 loadbreak mounting back connected	—	—	—
140D332G20	Obsolete—contact Eaton	—	25 kV RBA4 loadbreak mounting back connected	—	—	—
140D340G11	8RDB2-VM	140D340G11	—	RDB2	8.3	200
140D340G12	15RDB2-VM	140D340G12	—	RDB2	15.5	200
140D340G13	25RDB2-VM	140D340G13	—	RDB2	25	200
140D340G14	38RDB2-VM	140D340G14	—	RDB2	38	200
140D340G16	8RDB2-HVM	140D340G16	—	RDB2	8.3	200
140D340G17	15RDB2-HVM	140D340G17	—	RDB2	15.5	200
140D340G18	25RDB2-HVM	140D340G18	—	RDB2	25	200
140D340G19	38RDB2-HVM	140D340G19	—	RDB2	38	200
140D340G20	RDB2-VL	140D340G20	—	RDB2	—	200
140D341G11	8RDB4-VM	140D341G11	—	RDB4	8.3	400
140D341G12	15RDB4-VM	140D341G12	—	RDB4	15.5	400
140D341G13	25RDB4-VM	140D341G13	—	RDB4	25	300
140D341G14	38RDB4-VM	140D341G14	—	RDB4	38	300
140D341G16	8RDB4-HVM	140D341G16	—	RDB4	8.3	400
140D341G17	15RDB4-HVM	140D341G17	—	RDB4	15.5	400
140D341G18	25RDB4-HVM	140D341G18	—	RDB4	25	400
140D341G19	38RDB4-HVM	140D341G19	—	RDB4	38	300
140D341G20	RDB4-VL	140D341G20	—	RDB4	—	300
140D342G11	8RDB8-VM	140D342G11	—	RDB8	8.3	720
140D342G12	15RDB8-VM	140D342G12	—	RDB8	15.5	720
140D342G13	25RDB8-VM	140D342G13	—	RDB8	25	540
140D342G14	38RDB8-VM	140D342G14	—	RDB8	38	540
140D342G16	8RDB8-HVM	140D342G16	—	RDB8	8.3	720
140D342G17	15RDB8-HVM	140D342G17	—	RDB8	15.5	720
140D342G18	25RDB8-HVM	140D342G18	—	RDB8	25	540
140D342G19	38RDB8-HVM	140D342G19	—	RDB8	38	540
140D342G20	RDB8-VL	140D342G20	—	RDB8	—	720
140D346G11	8RDB2-UM	140D346G11	—	RDB2	8.3	200
140D346G12	15RDB2-UM	140D346G12	—	RDB2	15.5	200
140D346G13	25RDB2-UM	140D346G13	—	RDB2	25	200
140D346G14	38RDB2-UM	140D346G14	—	RDB2	38	200
140D346G16	8RDB2-HUM	140D346G16	—	RDB2	8.3	200
140D346G17	15RDB2-HUM	140D346G17	—	RDB2	15.5	200
140D346G18	25RDB2-HUM	140D346G18	—	RDB2	25	200
140D346G19	38RDB2-HUM	140D346G19	—	RDB2	38	200
140D346G20	RDB2-UL	140D346G20	—	RDB2	—	200
140D349G11	8RDB4-UM	140D349G11	—	RDB4	8.3	400
140D349G12	15RDB4-UM	140D349G12	—	RDB4	15.5	400
140D349G13	25RDB4-UM	140D349G13	—	RDB4	25	300
140D349G14	38RDB4-UM	140D349G14	—	RDB4	38	300
140D349G16	8RDB4-HUM	140D349G16	—	RDB4	8.3	400
140D349G17	15RDB4-HUM	140D349G17	—	RDB4	15.5	400
140D349G18	25RDB4-HUM	140D349G18	—	RDB4	25	400
140D349G19	38RDB4-HUM	140D349G19	—	RDB4	38	300
140D349G20	RDB4-UL	140D349G20	—	RDB4	—	300
140D354G11	8RDB8-UM	140D354G11	—	RDB8	8.3	720
140D354G12	15RDB8-UM	140D354G12	—	RDB8	15.5	720
140D354G13	25RDB8-UM	140D354G13	—	RDB8	25	540
140D354G14	38RDB8-UM	140D354G14	—	RDB8	38	540

Appendix 2—Superseded Style Number Index

Old 10 Digit Style Number	Current Eaton Catalog Number	Eaton 10 Digit Style Number	Description	Type	Voltage Rating kV Max.	Current Rating Amperes
140D354G16	8RDB8-HUM	140D354G16	—	RDB8	8.3	720
140D354G17	15RDB8-HUM	140D354G17	—	RDB8	15.5	720
140D354G18	25RDB8-HUM	140D354G18	—	RDB8	25	540
140D354G19	38RDB8-HUM	140D354G19	—	RDB8	38	540
140D354G20	RDB8-UL	140D354G20	—	RDB8	—	720
140D204G01	8CXN-60C	9570D01G01	—	CXN	8.3	60C
140D204G02	8CXN-100C	9570D01G02	—	CXN	8.3	100C
140D204G03	8CXN-125C	9570D01G03	—	CXN	8.3	125C
140D204G04	8CXN-150C	9570D01G04	—	CXN	8.3	150C
140D204G05	8CXN-200C	9570D01G05	—	CXN	8.3	200C
140D204G06	8CXN-250C	9570D01G06	—	CXN	8.3	250C
151D207G01	4ACLS-26R	151D207G01	—	CLS	4.6	26R(480)
151D213G01	15CLE-10E	5981C33G01	15CLO-10E	CLE	15.5	10E
151D213G02	15CLE-20E-D	5981C33G03	15CLO-20E	CLE	15.5	20E
151D213G03	15CLE-30E	5981C33G05	15CLO-30E	CLE	15.5	30E
151D213G04	15CLE-40E	5981C19G04	15CLO-40E	CLE	15.5	40E
151D213G05	15CLE-50E	5981C19G05	15CLO-50E	CLE	15.5	50E
151D213G06	15CLE-65E	5981C19G06	15CLO-65E	CLE	15.5	65E
151D213G09	15CLE-50E	5981C19G05	15CLO-50E	CLE	15.5	50E
151D213G10	15CLE-65E	5981C19G06	15CLO-65E	CLE	15.5	60E
151D213G11	Obsolete—contact Eaton	—	15CLO-10E (NI)	—	—	—
151D213G12	Obsolete—contact Eaton	—	15CLO-20E (NI)	—	—	—
151D213G13	Obsolete—contact Eaton	—	15CLO-30E (NI)	—	—	—
151D213G14	Obsolete—contact Eaton	—	15CLO-40E (NI)	—	—	—
151D213G15	Obsolete—contact Eaton	—	15CLO-50E (NI)	—	—	—
151D213G16	Obsolete—contact Eaton	—	15CLO-65E (NI)	—	—	—
151D214G04	15CLE-80E	5981C19G07	15CLO-80E	CLE	15.5	80E
151D214G05	15CLE-100E	5981C19G08	15CLO-100E	CLE	15.5	100E
151D214G06	15CLE-125E	5981C19G09	15CLO-125E	CLE	15.5	125E
151D218G02	15CXN-45C	9570D02G02	—	CXN	15.5	45C
151D218G03	15CXN-60C	9570D02G03	—	CXN	15.5	60V
151D218G04	15CXN-75C	9570D02G04	—	CXN	15.5	75C
151D218G05	15CXN-85C	9570D02G05	—	CXN	15.5	85C
151D218G06	15CXN-100C	9570D02G06	—	CXN	15.5	100C
151D240G01	5HCLS-30	151D240G01	—	CLS	5.08	30
151D240G02	5HCLS-2R	151D240G02	—	CLS	5.08	2R(70)
151D240G03	5HCLS-3R	151D240G03	—	CLS	5.08	3R(100)
151D240G04	5HCLS-4R	151D240G04	—	CLS	5.08	4R(130)
151D240G05	5HCLS-4R	151D240G05	—	CLS	5.08	5R(150)
151D240G06	5HCLS-6R	151D240G06	—	CLS	5.08	6R(170)
151D241G01	5CLS-30	151D241G01	—	CLS	5.08	30
151D241G02	5CLS-2R	151D241G02	—	CLS	5.08	2R(70)
151D241G03	5CLS-3R	151D241G03	—	CLS	5.08	3R(100)
151D241G04	5CLS-4R	151D241G04	—	CLS	5.08	4R(130)
151D241G05	5CLS-5R	151D241G05	—	CLS	5.08	5R(150)
151D241G06	5CLS-6R	151D241G06	—	CLS	5.08	6R(170)
151D251302	Obsolete—contact Eaton	—	15CLB-45C	—	—	—
151D251303	Obsolete—contact Eaton	—	15CLB-60C	—	—	—
151D253G01	4CX-18C	5978C62G01	—	CX	4.3	18C
151D253G02	4CX-25C	5978C62G02	—	CX	4.3	25C
151D253G03	4CX-35C	5978C62G03	—	CX	4.3	35C
151D253G04	4CX-45C	5978C66G01	—	CX	4.3	45C
151D253G05	4CX-50C	5978C66G02	—	CX	4.3	50C

Appendix 2—Superseded Style Number Index

Old 10 Digit Style Number	Current Eaton Catalog Number	Eaton 10 Digit Style Number	Description	Type	Voltage Rating kV Max.	Current Rating Amperes
151D253G06	4CX-60C	151D253G06	—	CX	4.3	60C
151D253G07	4CX-75C	5978C66G04	—	CX	4.3	75C
151D253G08	4CX-80C	151D253G08	—	CX	4.3	80C
151D253G26	4CXI-60C	151D253G26	—	CX	4.3	60C
151D253G28	4CXI-80C	151D253G28	—	CX	4.3	80C
151D254G01	5CX-10C	151D254G11	—	CX	5.5	10C
151D254G02	5CX-12C	151D254G12	—	CX	5.5	12C
151D254G03	5CX-18C	5978C70G01	—	CX	5.5	18C
151D254G04	5CX-21C	151D254G04	—	CX	5.5	21C
151D254G05	5CX-25C	5978C70G03	—	CX	5.5	25C
151D254G06	5CX-35C	151D254G06	—	CX	5.5	35C
151D254G07	5CX-40C	5978C70G05	—	CX	5.5	40C
151D254G08	5CX-50C	5978C70G06	—	CX	5.5	50C
151D254G09	5CX-60C	151D254G09	—	CX	5.5	60C
151D254G11	5CX-10C	151D254G11	—	CX	5.5	10C
151D254G12	5CX-12C	151D254G12	—	CX	5.5	12C
151D254G24	5CXI-21C	151D254G24	—	CX	5.5	21C
151D254G26	5CXI-35C	151D254G26	—	CX	5.5	35C
151D254G29	5CXI_60C	151D254G29	—	CX	5.5	60C
151D254G31	5CXI-10C	151D254G31	—	CX	5.5	10C
151D254G32	5CXI-12C	151D254G32	—	CX	5.5	12C
151D255G01	8CX-3.5C	151D255G01	—	CX	8.3	3.5C
151D255G02	8CX-4C	151D255G02	—	CX	8.3	4C
151D255G03	8CX-7C	151D255G03	—	CX	8.3	7C
151D255G04	8CX-10C	151D255G11	—	CX	8.3	10C
151D255G05	8CX-12C	151D255G12	—	CX	8.3	12C
151D255G06	8CX-15C	151D255G06	—	CX	8.3	15C
151D255G07	8CX-18C	5978C72G01	—	CX	8.3	18C
151D255G08	8CX-25C	5978C72G03	—	CX	8.3	25C
151D255G09	8CX-35C	151D255G09	—	CX	8.3	35C
151D255G10	8CX-40C	5978C72G05	—	CX	8.3	40C
151D255G11	8CX-10C	151D255G11	—	CX	8.3	10C
151D255G12	8CX-12C	151D255G12	—	CX	8.3	12C
151D255G21	8CXI-3.5C	151D255G21	—	CX	8.3	3.5C
151D255G22	8CXI-4C	151D255G22	—	CX	8.3	4C
151D255G23	8CXI-7C	151D255G23	—	CX	8.3	7C
151D255G26	8CXI-15C	151D255G26	—	CX	8.3	15C
151D255G29	8CXI-35C	151D255G29	—	CX	8.3	35C
151D255G31	8CXI-10C	151D255G31	—	CX	8.3	10C
151D255G32	8CXI-12C	151D255G32	—	CX	8.3	12C
151D256G01	8CLS-15	151D256G01	—	CLS	8.3	15
151D256G02	8CLS-30	151D256G02	—	CLS	8.3	30
151D256G03	8CLS-60	151D256G03	—	CLS	8.3	60
151D256G04	8CLS-70	151D256G04	—	CLS	8.3	70
151D256G05	8CLS-90	151D256G05	—	CLS	8.3	90
151D256G06	8CLS-110	151D256G06	—	CLS	8.3	110
151D256G07	8CLS-125	151D256G07	—	CLS	8.3	125
151D256G11	8CLS-150	151D256G11	—	CLS	8.3	150
151D256G12	8CLS-200	151D256G12	—	CLS	8.3	200
151D256G13	8CLS-225	151D256G13	—	CLS	8.3	225
151D257G01	5CLS75-36R	151D257G01	—	CLS	5.08	36R(650)
151D257G02	5CLS75-32R	151D257G02	—	CLS	5.08	32R(600)
151D257G03	151D257G03	151D257G03	Bolt in quads	CLS	5.08	(1170)

Appendix 2—Superseded Style Number Index

Old 10 Digit Style Number	Current Eaton Catalog Number	Eaton 10 Digit Style Number	Description	Type	Voltage Rating kV Max.	Current Rating Amperes
151D257G04	151D257G04	151D257G04	Bolt in quads	CLS	5.08	(1080)
151D257G05	5CLS75-24R	5CLS75-24R	—	CLS	5.08	24R(450)
151D883G01	15CX-3.5C	151D883G01	—	CX	15.5	3.5C
151D883G02	15CX-4C	151D883G02	—	CX	15.5	4C
151D883G03	15CX-7C	151D883G11	—	CX	15.5	7C
151D883G04	15CX-12C	151D883G12	—	CX	15.5	12C
151D883G06	15CX-15C	151D883G06	—	CX	15.5	15C
151D883G09	15CX-35C	151D883G09	—	CX	15.5	35C
151D883G11	15CX-10C	151D883G11	—	CX	15.5	10C
151D883G12	15CX-3C	151D883G12	—	CX	15.5	12C
151D883G21	15CXI-3.5C	151D883G21	—	CX	15.5	3.5C
151D883G22	15CXI-4C	151D883G22	—	CX	15.5	4C
151D883G23	15CXI-7C	151D883G23	—	CX	15.5	7C
151D883G26	15CXI-15C	151D883G26	—	CX	15.5	15C
151D883G29	15CXI-35C	151D883G29	—	CX	15.5	35C
151D883G31	15CXI-10C	151D883G31	—	CX	15.5	10C
151D883G32	15CXI-3C	151D883G32	—	CX	15.5	12C
151D884G01	5CX-GNM-G	151D884G01	—	CX	5.5	100
151D884G02	8CX-GNM-G	151D884G02	—	CX	8.3	40
151D884G03	15CX-GNM-G	151D884G03	—	CX	15.5	40
151D884G08	CX-NL	151D884G08	—	CX	—	100
151D885G01	5CX-GDM-G	151D885G01	—	CX	5.5	100
151D885G02	8CX-GDM-G	151D885G02	—	CX	8.3	40
151D885G03	15CX-GDM-G	151D885G03	—	CX	15.5	40
151D885G05	CX-DL	151D885G05	—	CX	—	100
151D885G06	CX-DF	151D885G06	—	CX	—	100
151D907G01	2CLE-PNM-D	9078A68G15	—	CLE	2.75	250
151D907G02	5CLE-PNM-D	9078A68G16	—	CLE	5.5	250
151D907G03	8CLE-PNM-D	9078A68G17	—	CLE	8.3	175
151D907G04	15CLE-PNM-D	9078A68G18	—	CLE	15.5	150
151D907G05	15CLE-HPNM-D	9078A68G19	—	CLE	15.5	150
151D907G07	Obsolete—contact Eaton	—	Obsolete 2.4 kV top rear con. mounting	CLE	—	—
151D907G08	Obsolete—contact Eaton	—	Obsolete 4.8 kV top rear con. mounting	CLE	—	—
151D907G09	Obsolete—contact Eaton	—	Obsolete 7.2 kV top rear con. mounting	CLE	—	—
151D907G10	Obsolete—contact Eaton	—	Obsolete 13.8 kV top rear con. mounting	CLE	—	—
151D907G11	Obsolete—contact Eaton	—	Obsolete 14.4 kV top rear con. mounting	CLE	—	—
151D907G13	Obsolete—contact Eaton	—	Obsolete 2.4 kV double rear con. mounting	CLE	—	—
151D907G14	Obsolete—contact Eaton	—	Obsolete 4.8 kV double rear con. mounting	CLE	—	—
151D907G15	Obsolete—contact Eaton	—	Obsolete 7.2 kV double rear con. mounting	CLE	—	—
151D907G16	Obsolete—contact Eaton	—	Obsolete 13.8 kV double rear con. mounting	CLE	—	—
151D907G17	Obsolete—contact Eaton	—	Obsolete 14.4 kV double rear con. mounting	CLE	—	—
151D907G19	Obsolete—contact Eaton	—	Obsolete 2.4 kV bottom rear con. mounting	CLE	—	—
151D907G20	Obsolete—contact Eaton	—	Obsolete 4.8 kV bottom rear con. mounting	CLE	—	—
151D907G21	Obsolete—contact Eaton	—	Obsolete 7.2 kV bottom rear con. mounting	CLE	—	—
151D907G22	Obsolete—contact Eaton	—	Obsolete 13.8 kV bottom rear con. mounting	CLE	—	—
151D907G23	Obsolete—contact Eaton	—	Obsolete 14.4 kV bottom rear con. mounting	CLE	—	—
151D909G01	2CLE-PNM-E	9078A68G20	—	CLE	2.75	450
151D909G02	5CLE-PNM-E	9078A68G21	—	CLE	5.5	450
151D909G03	8CLE-PNM-E	9078A68G22	—	CLE	8.3	350
151D909G04	15CLE-PNM-E	9078A68G23	—	CLE	15.5	300
151D909G05	15CLE-HPNM-E	9078A68G24	—	CLE	15.5	300
151D909G07	Obsolete—contact Eaton	—	Obsolete 2.4 kV top rear con. mounting	CLE	—	—
151D909G08	Obsolete—contact Eaton	—	Obsolete 4.8 kV top rear con. mounting	CLE	—	—

Appendix 2—Superseded Style Number Index

Old 10 Digit Style Number	Current Eaton Catalog Number	Eaton 10 Digit Style Number	Description	Type	Voltage Rating kV Max.	Current Rating Amperes
151D909G09	Obsolete—contact Eaton	—	Obsolete 7.2 kV top rear con. mounting	CLE	—	—
151D909G10	Obsolete—contact Eaton	—	Obsolete 14.4 kV top rear con. mounting	CLE	—	—
151D909G13	Obsolete—contact Eaton	—	Obsolete 2.4 kV double rear con. mounting	CLE	—	—
151D909G14	Obsolete—contact Eaton	—	Obsolete 4.8 kV double rear con. mounting	CLE	—	—
151D909G15	Obsolete—contact Eaton	—	Obsolete 7.2 kV double rear con. mounting	CLE	—	—
151D909G16	Obsolete—contact Eaton	—	Obsolete 14.4 kV double rear con. mounting	CLE	—	—
151D909G19	Obsolete—contact Eaton	—	Obsolete 2.4 kV bottom rear con. mounting	CLE	—	—
151D909G20	Obsolete—contact Eaton	—	Obsolete 4.8 kV bottom rear con. mounting	CLE	—	—
151D909G21	Obsolete—contact Eaton	—	Obsolete 7.2 kV bottom rear con. mounting	CLE	—	—
151D909G22	Obsolete—contact Eaton	—	Obsolete 14.4 kV bottom rear con. mounting	CLE	—	—
151D911G06	5ACLS-9R	151D933G01	Tin plated ferrule	CLS	5.08	9R(200)
151D927G01	Contact EATON	—	Two—parallel 15CXN-60C	—	—	—
151D927G02	Contact EATON	—	Two—parallel 15CXN-75C	—	—	—
151D927G03	Contact EATON	—	Two—parallel 15CXN-85C	—	—	—
151D927G05	Contact EATON	—	Two—parallel 8CXN-150C	—	—	—
151D930G02	Obsolete—contact Eaton	—	15CLTX-15K	—	—	—
151D930G03	Obsolete—contact Eaton	—	8CLTX-15K	—	—	—
151D930G04	Obsolete—contact Eaton	—	8CLTX-40K	—	—	—
151D930G05	Obsolete—contact Eaton	—	15CLTX-40K	—	—	—
151D930G06	Obsolete—contact Eaton	—	23CLTX-15K	—	—	—
151D930G07	Obsolete—contact Eaton	—	8CLTX-25K	—	—	—
151D930G08	Obsolete—contact Eaton	—	15CLTX-25K	—	—	—
151D932G01	6DSL-C800	151D932G01	—	DSL	0.6	800
151D932G02	6DSL-C1000	151D932G02	—	DSL	0.6	1000
151D932G03	6DSL-C1200	151D932G03	—	DSL	0.6	1200
151D932G04	6DSL-C1600	151D932G04	—	DSL	0.6	1600
151D932G05	6DSL-C2000	151D932G05	—	DSL	0.6	2000
151D932G09	6DSL-D2500	151D932G09	—	DSL	0.6	2500
151D932G10	6DSL-D3000	151D932G10	—	DSL	0.6	3000
151D933G01	5ACLS-9R	151D933G01	—	CLS	5.08	9R(200)
151D933G02	5ACLS-12R	151D933G02	—	CLS	5.08	12R(230)
151D933G03	5ACLS-18R	151D933G03	—	CLS	5.08	18R(390)
151D933G04	5ACLS-24R	151D933G04	—	CLS	5.08	24R(450)
151D937G01	Obsolete—contact Eaton	151D937G01	2HCLE-25E sealed with hookeye	—	—	—
151D937G02	Obsolete—contact Eaton	151D937G02	2HCLE-30E sealed with hookeye	—	—	—
151D937G03	Obsolete—contact Eaton	151D937G03	2HCLE-50E sealed with hookeye	—	—	—
151D937G04	Obsolete—contact Eaton	151D937G04	2HCLE-65E sealed with hookeye	—	—	—
151D937G05	Obsolete—contact Eaton	151D937G05	2HCLE-80E sealed with hookeye	—	—	—
151D937G06	Obsolete—contact Eaton	151D937G06	2HCLE-100E sealed with hookeye	—	—	—
151D937G07	Obsolete—contact Eaton	151D937G07	2HCLE-125E sealed with hookeye	—	—	—
151D937G08	Obsolete—contact Eaton	151D937G08	2HCLE-150E sealed with hookeye	—	—	—
151D937G09	Obsolete—contact Eaton	151D937G09	2HCLE-200E sealed with hookeye	—	—	—
151D937G10	Obsolete—contact Eaton	151D937G10	2HCLE-225E sealed with hookeye	—	—	—
151D937G13	Obsolete—contact Eaton	151D937G13	2HCLE-250E sealed with hookeye	—	—	—
151D937G14	Obsolete—contact Eaton	151D937G14	2HCLE-300E sealed with hookeye	—	—	—
151D937G15	Obsolete—contact Eaton	151D937G15	2HCLE-350E sealed with hookeye	—	—	—
151D937G16	Obsolete—contact Eaton	151D937G16	2HCLE-365E sealed with hookeye	—	—	—
151D937G17	Obsolete—contact Eaton	151D937G17	2HCLE-400E sealed with hookeye	—	—	—
151D938G01	5AHLE-25E	5981C46G04	—	HLE	5.5	25E
151D938G02	5AHLE-30E	5981C46G05	—	HLE	5.5	30E
151D938G03	5AHLE-50E	5981C46G07	—	HLE	5.5	50E
151D938G04	5AHLE-65E	5981C46G08	—	HLE	5.5	65E
151D938G05	5AHLE-80E	5981C46G09	—	HLE	5.5	80E

Appendix 2—Superseded Style Number Index

Old 10 Digit Style Number	Current Eaton Catalog Number	Eaton 10 Digit Style Number	Description	Type	Voltage Rating kV Max.	Current Rating Amperes
151D938G06	5AHLE100E	5981C46G10	—	HLE	5.5	100E
151D938G07	5AHLE-125E	5981C46G11	—	HLE	5.5	125E
151D938G08	5AHLE-150E	5981C46G12	—	HLE	5.5	150E
151D938G09	5AHLE-200E	5981C46G14	—	HLE	5.5	200E
151D938G10	Obsolete—contact Eaton	—	—	HLE	5.5	250E
151D939G01	5AHLE-250E	5981C46G15	—	HLE	5.5	250E
151D939G02	5AHLE-300E	5981C46G16	—	HLE	5.5	300E
151D939G03	5AHLE-400E	5981C46G18	—	HLE	5.5	400E
151D961G01	5CLS-9R	151D961G01	—	CLS	5.08	9R(200)
151D961G02	5CLS-12R	151D961G02	—	CLS	5.08	12R(230)
151D961G03	5CLS-18R	151D961G03	—	CLS	5.08	18R(390)
151D961G04	5CLS-24R	151D961G04	—	CLS	5.08	24R(450)
151D962G01	5HCLS-9R	151D962G01	—	CLS	5.08	9R(200)
151D962G02	5HCLS-12R	151D962G02	—	CLS	5.08	12R(230)
151D962G03	5HCLS-18R	151D962G03	—	CLS	5.08	18R(390)
151D962G04	5HCLS-24R	151D962G04	—	CLS	5.08	24R(450)
151D963G01	8ACLS-2R	151D963G01	—	CLS	8.3	2R(70)
151D963G02	8ACLS-3R	151D963G02	—	CLS	8.3	3R(100)
151D963G03	8ACLS-4R	151D963G03	—	CLS	8.3	4R(130)
151D963G04	8ACLS-5R	151D963G04	—	CLS	8.3	5R(150)
151D963G05	8ACLS-6R	151D963G05	—	CLS	8.3	6R(170)
151D963G06	7ACLS-9R	151D963G06	—	CLS	7.2	9R(200)
151D963G07	7ACLS-12R	151D963G07	—	CLS	7.2	12R(230)
151D963G10	7ACLS-18R	151D963G10	—	CLS	7.2	18R(390)
151D963G11	7ACLS-24R	151D963G11	—	CLS	7.2	24R(450)
151D967G01	Obsolete—contact Eaton	—	3.65 kV	CLS	—	—
151D967G02	Obsolete—contact Eaton	—	3.65 kV	CLS	—	—
151D967G03	Obsolete—contact Eaton	—	3.65 kV	CLS	—	—
151D967G04	Obsolete—contact Eaton	—	3.65 kV	CLS	—	—
151D967G05	Obsolete—contact Eaton	—	3.65 kV	CLS	—	—
151D967G06	Obsolete—contact Eaton	—	3.65 kV	CLS	—	—
151D967G07	Obsolete—contact Eaton	—	3.65 kV	CLS	—	—
151D967G08	Obsolete—contact Eaton	—	3.65 kV	CLS	—	—
151D967G09	Obsolete—contact Eaton	—	3.65 kV	CLS	—	—
151D967G10	Obsolete—contact Eaton	—	3.65 kV	CLS	—	—
151D978G01	5HLE-30E	5981C28G05	—	HLE	5.5	30E
151D978G02	5HLE-50E	5981C64G02	—	HLE	5.5	50E
151D978G03	5HLE-65E	5981C64G03	—	HLE	5.5	65E
151D978G04	5HLE-80E	5981C64G04	—	HLE	5.5	80E
151D978G05	5HLE-100E	5981C64G05	—	HLE	5.5	100E
151D978G06	5HLE-125E	5981C64G06	—	HLE	5.5	125E
151D978G07	5HLE-150E	5981C64G07	—	HLE	5.5	150E
151D978G08	5HLE-200E	5981C64G09	—	HLE	5.5	200E
151D978G09	Obsolete—contact Eaton	—	5SCLE-225E	—	—	—
151D978G11	5HLE-250E	5981C64G10	—	HLE	5.5	250E
151D978G12	5HLE-300E	5981C66G01	—	HLE	5.5	300E
151D978G13	5HLE-400E	5981C66G03	—	HLE	5.5	400E
151D979G01	5CLS70-600E	151D979G01	—	CLE	5.5	600E
151D979G02	5CLS70-750E	151D979G02	—	CLE	5.5	750E
18A7330G13	38DBA2-5E	18A7330G13	—	DBA2	38	5E
18A7330G14	38DBA2-7E	18A7330G14	—	DBA2	38	7E
18A7330G15	38DBA2-10E	18A7330G15	—	DBA2	38	10E
18A7330G16	38DBA2-15E	18A7330G16	—	DBA2	38	15E

Appendix 2—Superseded Style Number Index

Old 10 Digit Style Number	Current Eaton Catalog Number	Eaton 10 Digit Style Number	Description	Type	Voltage Rating kV Max.	Current Rating Amperes
18A7330G17	38DBA2-20E	18A7330G17	—	DBA2	38	20E
18A7330G18	38DBA2-25E	18A7330G18	—	DBA2	38	25E
18A7330G19	38DBA2-30E	18A7330G19	—	DBA2	38	30E
18A7330G20	38DBA2-40E	18A7330G20	—	DBA2	38	40E
18A7330G21	38DBA2-50E	18A7330G21	—	DBA2	38	50E
18A7330G22	38DBA2-65E	18A7330G22	—	DBA2	38	65E
18A7330G23	38DBA2-80E	18A7330G23	—	DBA2	38	80E
18A7330G24	38DBA2-100E	18A7330G24	—	DBA2	38	100E
18A7330G25	38DBA2-125E	18A7330G25	—	DBA2	38	125E
18A7330G26	38DBA2-150E	18A7330G26	—	DBA2	38	150E
18A7330G27	38DBA2-200E	18A7330G27	—	DBA2	38	200E
18A7330G33	48DBA2-5E	18A7330G33	—	DBA2	48	5E
18A7330G34	48DBA2-7E	18A7330G34	—	DBA2	48	7E
18A7330G35	48DBA2-10E	18A7330G35	—	DBA2	48	10E
18A7330G36	48DBA2-15E	18A7330G36	—	DBA2	48	15E
18A7330G37	48DBA2-20E	18A7330G37	—	DBA2	48	20E
18A7330G48	48DBA2-25E	18A7330G48	—	DBA2	48	25E
18A7330G39	48DBA2-30E	18A7330G39	—	DBA2	48	30E
18A7330G40	48DBA2-40E	18A7330G40	—	DBA2	48	40E
18A7330G41	48DBA2-50E	18A7330G41	—	DBA2	48	50E
18A7330G42	48DBA2-65E	18A7330G42	—	DBA2	48	65E
18A7330G43	48DBA2-80E	18A7330G43	—	DBA2	48	80E
18A7330G44	48DBA2-100E	18A7330G44	—	DBA2	48	100E
18A7330G45	48DBA2-125E	18A7330G45	—	DBA2	48	125E
18A7330G46	48DBA2-150E	18A7330G46	—	DBA2	48	150E
18A7330G47	48DBA2-200E	18A7330G47	—	DBA2	48	200E
18B1154G07	5CLS-12R	676C546	225E 2.4 kV CLS-1 fuse	CLS	5.08	12R(230)
18B3115A10	Obsolete	—	2.4 kV CLE-1 mountings	—	—	—
2A98253G01	5ACLS-30	449D597G02	Asheville 3 pack	—	—	—
2A98253G02	5ACLS-2R	449D597G01	Asheville 3 pack	—	—	—
2A98253G03	5ACLS-3R	449D597G03	Asheville 3 pack	—	—	—
2A98253G04	5ACLS-4R	449D597G04	Asheville 3 pack	—	—	—
2A98253G05	5ACLS-5R	449D597G05	Asheville 3 pack	—	—	—
2A98253G06	5ACLS-6R	449D597G06	Asheville 3 pack	—	—	—
2A98253G07	5ACLS-9R	151D933G01	Asheville 3 pack	—	—	—
2A98253G08	5ACLS-12R	151D933G02	Asheville 3 pack	—	—	—
2A98253G09	5ACLS-18R	151D933G03	Asheville 3 pack	—	—	—
2A98253G10	5ACLS-24R	151D933G04	Asheville 3 pack	—	—	—
2A98253G11	5CLS70-24R	140D045G03	Asheville 3 pack	—	—	—
2A98253G12	5CLS70-36R	140D045G02	Asheville 3 pack	—	—	—
2A98253G13	5CLS70-44R	140D045G05	Asheville 3 pack	—	—	—
2A98253G21	8ACLS-2R	151D963G01	Asheville 3 pack	—	—	—
2A98253G22	8ACLS-3R	151D963G02	Asheville 3 pack	—	—	—
2A98253G23	8ACLS-4R	151D963G03	Asheville 3 pack	—	—	—
2A98253G24	8ACLS-5R	151D963G04	Asheville 3 pack	—	—	—
2A98253G25	8ACLS-6R	151D963G05	Asheville 3 pack	—	—	—
2A98253G26	7ACLS-9R	151D963G06	Asheville 3 pack	—	—	—
2A98253G27	7ACLS-12R	151D963G07	Asheville 3 pack	—	—	—
2A98253G28	7ACLS18R	151D963G10	Asheville 3 pack	—	—	—
2A98253G29	7ACLS-24R	151D963G11	Asheville 3 pack	—	—	—
2A98253G30	7CLS70-24R	5987C91G01	Asheville 3 pack	—	—	—
2A98253G31	7CLS70-36R	5987C91G02	Asheville 3 pack	—	—	—
2A98253G32	7CLS70-44R	5980C03G01	Asheville 3 pack	—	—	—

Appendix 2—Superseded Style Number Index

Old 10 Digit Style Number	Current Eaton Catalog Number	Eaton 10 Digit Style Number	Description	Type	Voltage Rating kV Max.	Current Rating Amperes
2A98253G39	8ACLS-4L	5981C27G02	Asheville 3 pack	—	—	—
2A98253G40	CLS-700 DUMMY	591C172G01	Asheville 3 pack	—	—	—
2A98253G41	5AHLE-10E	5981C46G01	Asheville 3 pack	—	—	—
2A98253G42	5AHLE-15E	5981C46G02	Asheville 3 pack	—	—	—
2A98253G43	5AHLE-20E	5981C46G03	Asheville 3 pack	—	—	—
2A98253G44	5AHLE-25E	5981C46G04	Asheville 3 pack	—	—	—
2A98253G45	5AHLE-30E	5981C46G05	Asheville 3 pack	—	—	—
2A98253G46	5AHLE-40E	5981C46G06	Asheville 3 pack	—	—	—
2A98253G47	5AHLE-50E	5981C46G07	Asheville 3 pack	—	—	—
2A98253G48	5AHLE-65E	5981C46G08	Asheville 3 pack	—	—	—
2A98253G49	5AHLE-80E	5981C46G09	Asheville 3 pack	—	—	—
2A98253G50	5AHLE-100E	5981C46G10	Asheville 3 pack	—	—	—
2A98253G51	5AHLE-125E	5981C46G11	Asheville 3 pack	—	—	—
2A98253G52	5AHLE-150E	5981C46G12	Asheville 3 pack	—	—	—
2A98253G53	5AHLE-200E	5981C46G14	Asheville 3 pack	—	—	—
2A98253G54	5ACLE-225E	449D362G09	Asheville 3 pack	—	—	—
2A98253G55	5AHLE-250E	5981C46G15	Asheville 3 pack	—	—	—
2A98253G56	5AHLE-300E	5981C46G16	Asheville 3 pack	—	—	—
2A98253G57	5AHLE-350E	5981C46G17	Asheville 3 pack	—	—	—
2A98253G58	5AHLE-400E	5981C46G18	Asheville 3 pack	—	—	—
2A98253G59	5AHLE-450E	5981C46G19	Asheville 3 pack	—	—	—
2A98253G60	5CLS70-600E	151D979G01	Asheville 3 pack	—	—	—
2A98253G61	5CLS70-750E	151D979G02	Asheville 3 pack	—	—	—
2A98253G62	5BCLS-600E	9570D64G04	Asheville 3 pack	—	—	—
2A98253G63	5BCLS-750E	9570D64G05	Asheville 3 pack	—	—	—
2A98253G64	5CLE-1100E	9570D70G01	Asheville 3 pack	—	—	—
2A98253G65	5CLE-1350E	9570D70G02	Asheville 3 pack	—	—	—
2A98253G71	8AHLE-10E	5981C47G01	Asheville 3 pack	—	—	—
2A98253G72	8AHLE-15E	5981C47G02	Asheville 3 pack	—	—	—
2A98253G73	8AHLE-20E	5981C47G03	Asheville 3 pack	—	—	—
2A98253G74	8AHLE-25E	5981C47G04	Asheville 3 pack	—	—	—
2A98253G75	8AHLE-30E	5981C47G05	Asheville 3 pack	—	—	—
2A98253G76	8AHLE-40E	5981C47G06	Asheville 3 pack	—	—	—
2A98253G77	8AHLE-50E	5981C47G07	Asheville 3 pack	—	—	—
2A98253G78	8AHLE-65E	5981C47G08	Asheville 3 pack	—	—	—
2A98253G79	8AHLE-80E	5981C47G09	Asheville 3 pack	—	—	—
2A98253G80	8AHLE-100E	5981C47G10	Asheville 3 pack	—	—	—
2A98253G81	8AHLE-125E	5981C47G11	Asheville 3 pack	—	—	—
2A98253G82	8AHLE-150E	5981C47G12	Asheville 3 pack	—	—	—
2A98253G83	8AHLE-175E	5981C47G13	Asheville 3 pack	—	—	—
2A98253G84	8AHLE-200E	5981C47G14	Asheville 3 pack	—	—	—
2A98253G85	8AHLE-250E	5981C47G15	Asheville 3 pack	—	—	—
2A98253G86	8AHLE-300E	5981C47G16	Asheville 3 pack	—	—	—
204B956G01	Obsolete—contact Eaton	—	BAL mounting conversion kit	—	—	—
204B956G02	Obsolete—contact Eaton	—	BAL mounting conversion kit	—	—	—
204B956G03	Obsolete—contact Eaton	—	BAL mounting conversion kit	—	—	—
204B956G04	Obsolete—contact Eaton	—	BAL mounting conversion kit	—	—	—
204B956G05	Obsolete—contact Eaton	—	BAL mounting conversion kit	—	—	—
204B956G06	Obsolete—contact Eaton	—	BAL mounting conversion kit	—	—	—
208D480G02	2CLS-2R	591C812G02	—	CLS	2.54	2R(70)
208D480G04	2CLS-4R	591C812G04	—	CLS	2.54	4R(130)
208D480G06	2CLS-6R	591C812G06	—	CLS	2.54	6R(170)
208D480G07	2CLS-9R	591C812G07	—	CLS	2.54	9R(200)

Appendix 2—Superseded Style Number Index

Old 10 Digit Style Number	Current Eaton Catalog Number	Eaton 10 Digit Style Number	Description	Type	Voltage Rating kV Max.	Current Rating Amperes
208D480G08	2CLS-12R	591C812G08	—	CLS	2.54	12R(230)
208D481G01	2CLE-30E	449D797G02	—	CLE	2.75	30E
208D481G03	2CLE-50E	449D797G03	—	CLE	2.75	50E
208D481G04	2CLE-65E	449D797G04	—	CLE	2.75	65E
208D481G05	2CLE-80E	449D797G05	—	CLE	2.75	80E
208D481G06	2CLE-100E	449D797G06	—	CLE	2.75	100E
208D481G07	2CLE-125E	449D797G07	—	CLE	2.75	125E
208D481G08	2CLE-150E	449D797G08	—	CLE	2.75	150E
208D481G09	2CLE-200E	449D797G09	—	CLE	2.75	200E
208D502G01	15CLE-30E	5981C33G05	—	CLE	15.5	30E
208D502G02	15CLE-40E	5981C19G04	—	CLE	15.5	40E
208D502G03	15CLE-50E	5981C19G05	—	CLE	15.5	50E
208D502G04	15CLE-65E	5981C19G06	—	CLE	15.5	65E
208D502G05	15CLE-80E	5981C19G07	—	CLE	15.5	80E
208D502G06	15CLE-100E	5981C19G08	—	CLE	15.5	100E
21A5008A10	5CLPT-5E	677C453G01	—	CLPT	5.5	5E
22A6782G04	38DBA2-.5E	22A6782G04	—	DBA2	38	0.5
22A6782G05	48DBA2-.5E	22A6782G05	—	DBA2	48	0.5
22A6782G06	72DBA2-.5E	22A6782G06	—	DBA2	72	0.5
304C108G01	Obsolete—contact Eaton	—	BA-200 7.2 kV mounting	—	—	—
304C108G02	Obsolete—contact Eaton	—	BA-200 14.4 kV mounting	—	—	—
304C108G03	Obsolete—contact Eaton	—	BA-200 23 kV mounting	—	—	—
304C108G04	Obsolete—contact Eaton	—	BA-200 34.5 kV mounting	—	—	—
304C108G05	Obsolete—contact Eaton	—	BA-200 7.2/14.4 kV mounting	—	—	—
304C108G06	Obsolete—contact Eaton	—	BA-200 14.4/23 kV mounting	—	—	—
304C108G07	Obsolete—contact Eaton	—	BA-200 23/34.5 kV mounting	—	—	—
304C108G08	Obsolete—contact Eaton	—	BA-200 34.5/46 kV mounting	—	—	—
304C109G01	Obsolete—contact Eaton	—	BA-400 7.2 kV mounting	—	—	—
304C109G02	Obsolete—contact Eaton	—	BA-400 14.4 kV mounting	—	—	—
304C109G03	Obsolete—contact Eaton	—	BA-400 23 kV mounting	—	—	—
304C109G04	Obsolete—contact Eaton	—	BA-400 34.5 kV mounting	—	—	—
304C109G05	Obsolete—contact Eaton	—	BA-400 7.2/14.4 kV mounting	—	—	—
304C109G06	Obsolete—contact Eaton	—	BA-400 14.4/23 kV mounting	—	—	—
304C109G07	Obsolete—contact Eaton	—	BA-400 23/34.5 kV mounting	—	—	—
304C109G08	Obsolete—contact Eaton	—	BA-400 34.5/46 kV mounting	—	—	—
304C337G08	25CLPT-1E	677C452G09	—	CLPT	25.5	1
304C356G01	Obsolete—contact Eaton	—	BA-400 7.2 kV mounting	—	—	—
304C356G02	Obsolete—contact Eaton	—	BA-400 14.4 kV mounting	—	—	—
304C356G03	Obsolete—contact Eaton	—	BA-400 23 kV mounting	—	—	—
304C356G04	Obsolete—contact Eaton	—	BA-400 34.5 kV mounting	—	—	—
304C356G05	Obsolete—contact Eaton	—	BA-400 7.2/14.4 kV mounting	—	—	—
304C356G06	Obsolete—contact Eaton	—	BA-400 14.4/23 kV mounting	—	—	—
304C356G07	Obsolete—contact Eaton	—	BA-400 23/34.5 kV mounting	—	—	—
304C356G08	Obsolete—contact Eaton	—	BA-400 34.5/46 kV mounting	—	—	—
304C437G01	Obsolete—contact Eaton	—	BA-200 7.2 kV mounting	—	—	—
304C437G02	Obsolete—contact Eaton	—	BA-200 14.4 kV mounting	—	—	—
304C437G03	Obsolete—contact Eaton	—	BA-200 23 kV mounting	—	—	—
304C437G04	Obsolete—contact Eaton	—	BA-200 34.5 kV mounting	—	—	—
304C438G01	Obsolete—contact Eaton	—	BA-200 7.2 kV mounting	—	—	—
304C438G02	Obsolete—contact Eaton	—	BA-200 14.4 kV mounting	—	—	—
304C438G03	Obsolete—contact Eaton	—	BA-200 23 kV mounting	—	—	—
304C438G04	Obsolete—contact Eaton	—	BA-200 34.5 kV mounting	—	—	—
304C444G01	Obsolete—contact Eaton	—	BA-200 7.2 kV mounting	—	—	—

Appendix 2—Superseded Style Number Index

Old 10 Digit Style Number	Current Eaton Catalog Number	Eaton 10 Digit Style Number	Description	Type	Voltage Rating kV Max.	Current Rating Amperes
304C444G02	Obsolete—contact Eaton	—	BA-200 14.4 kV mounting	—	—	—
304C444G03	Obsolete—contact Eaton	—	BA-200 23 kV mounting	—	—	—
304C444G04	Obsolete—contact Eaton	—	BA-200 34.5 kV mounting	—	—	—
304C463G01	2CLS-18R	591C813G01	—	CLS	2.54	18R(390)
304C463G02	2CLS-24R	591C813G02	—	CLS	2.54	24R
304C463G03	5LCLS-24R	304C463G03	—	CLS	5.08	18R(390)
304C463G04	5LCLS-18R	304C463G04	—	CLS	5.08	24R
308C310G10	CLE-NL-E	9078A67G04	—	CLE	—	450
308C427A02	2CLE-PNM-D	9078A68G15	—	CLE	2.75	250
308C427A03	5CLE-PNM-D	9078A68G16	—	CLE	5.5	250
308C427A04	8CLE-PNM-D	9078A68G17	—	CLE	8.3	175
308C427A06	15CLE-PNM-D	9078A68G18	—	CLE	15.5	150
308C427A07	15CLE-HPNM-D	9078A68G19	—	CLE	15.5	150
308C427A11	Obsolete—contact Eaton	—	Rear connected non-disconnect CLE mountings	—	—	—
308C427A12	Obsolete—contact Eaton	—	Rear connected non-disconnect CLE mountings	—	—	—
308C427A13	Obsolete—contact Eaton	—	Rear connected non-disconnect CLE mountings	—	—	—
308C427A15	Obsolete—contact Eaton	—	Rear connected non-disconnect CLE mountings	—	—	—
308C427A16	Obsolete—contact Eaton	—	Rear connected non-disconnect CLE mountings	—	—	—
308C427A20	Obsolete—contact Eaton	—	Rear connected non-disconnect CLE mountings	—	—	—
308C427A21	Obsolete—contact Eaton	—	Rear connected non-disconnect CLE mountings	—	—	—
308C427A22	Obsolete—contact Eaton	—	Rear connected non-disconnect CLE mountings	—	—	—
308C427A24	Obsolete—contact Eaton	—	Rear connected non-disconnect CLE mountings	—	—	—
308C427A25	Obsolete	—	Rear connected non-disconnect CLE mountings	—	—	—
309C024G03	RBA2-FLTR	309C024G03	(3 pack)	RBA2	—	200
309C024G04	RBA4-FLTR	309C024G04	(3 pack)	RBA4	—	400
309C024G05	RBA2-FLTR-1	309C024G05	(1 pack)	RBA2	—	200
309C273G02	Obsolete—contact Eaton	—	BA-200 13.8 kV dummy fuse	—	—	—
309C548G01	8RDB2-SHNT	309C548G01	—	RDB2	8.3	200
309C548G02	15RDB2-SHNT	309C548G02	—	RDB2	15.5	200
309C548G03	25RDB2-SHNT	309C548G03	—	RDB2	25.5	200
309C548G04	38RDB2-SHNT	309C548G04	—	RDB2	38	200
309C548G05	8RBA2-SHNT	309C548G05	—	RBA2	8.3	200
309C548G06	15RBA2-SHNT	309C548G06	—	RBA2	15.5	200
309C548G07	25RBA2-SHNT	309C548G07	—	RBA2	25.5	200
309C548G08	38RBA2-SHNT	309C548G08	—	RBA2	38	200
309C548G09	8RBA2-ISHNT	309C548G09	—	RBA2	8.3	200
309C548G10	15RBA2-ISHNT	309C548G10	—	RBA2	15.5	200
309C548G11	25RBA2-ISHNT	309C548G11	—	RBA2	25.5	200
309C548G12	38RBA2-ISHNT	309C548G12	—	RBA2	38	200
309C558G01	8RBA2-DH	309C558G01	—	RBA2	8.3	200
309C558G02	15RBA2-DH	309C558G02	—	RBA2	15.5	200
309C558G03	25RBA2-DH	309C558G03	—	RBA2	25.5	200
309C558G04	38RBA2-DH	309C558G04	—	RBA2	38	200
309C558G05	8RDB2-DH	309C558G05	—	RDB2	8.3	200
309C558G06	15RDB2-DH	309C558G06	—	RDB2	15.5	200
309C558G07	25RDB2-DH	309C558G07	—	RDB2	25.5	200
309C558G08	38RDB2-DH	309C558G08	—	RDB2	38	200
309C558G09	8RBA2-LBDH	309C558G09	—	RBA2	8.3	200
309C558G10	15RBA2-LBDH	309C558G10	—	RBA2	15.5	200
309C558G11	25RBA2-LBDH	309C558G11	—	RBA2	25.5	200
309C660G02	2HCLS-2R	591C155G02	—	CLS	2.75	2R(70)
309C660G03	2HCLS-3R	591C155G03	—	CLS	2.75	B
309C660G04	2HCLS-4R	591C155G04	—	CLS	2.75	4R(130)

Appendix 2—Superseded Style Number Index

Old 10 Digit Style Number	Current Eaton Catalog Number	Eaton 10 Digit Style Number	Description	Type	Voltage Rating kV Max.	Current Rating Amperes
309C660G05	2HCLS-5R	591C155G05	—	CLS	2.75	5R(150)
309C660G06	2HCLS-6R	591C155G06	—	CLS	2.75	6R(170)
309C660G09	2HCLS-9R	591C155G07	—	CLS	2.75	9R(200)
309C660G12	2HCLS-12R	591C155G08	—	CLS	2.75	12R(230)
309C660G15	Obsolete—contact Eaton	—	Hermetically sealed 5LCLS-2R fuse	—	—	—
309C660G16	Obsolete—contact Eaton	—	Hermetically sealed 5LCLS-2R fuse	—	—	—
309C660G17	Obsolete—contact Eaton	—	Hermetically sealed 5LCLS-2R fuse	—	—	—
309C660G18	Obsolete—contact Eaton	—	Hermetically sealed 5LCLS-2R fuse	—	—	—
309C660G19	Obsolete—contact Eaton	—	Hermetically sealed 5LCLS-2R fuse	—	—	—
309C660G22	Obsolete—contact Eaton	—	Hermetically sealed 5LCLS-2R fuse	—	—	—
309C660G25	Obsolete—contact Eaton	—	Hermetically sealed 5LCLS-2R fuse	—	—	—
309C797G01	8RBA4-DH	309C797G01	—	RBA4	8.3	400
309C797G02	15RBA4-DH	309C797G02	—	RBA4	15.5	400
309C797G03	25RBA4-DH	309C797G03	—	RBA4	25.5	300
309C797G04	38RBA4-DH	309C797G04	—	RBA4	38	300
309C797G05	8RBA4-LBDH	309C797G05	—	RBA4	8.3	400
309C797G06	15RBA4-LBDH	309C797G06	—	RBA4	15.5	400
309C797G07	25RBA4-LBDH	309C797G07	—	RBA4	25.5	300
30A6178G01	Obsolete—contact Eaton	—	BA-800 7.2 kV mounting	—	—	—
30A6178G02	Obsolete—contact Eaton	—	BA-800 14.4 kV mounting	—	—	—
30A6178G03	Obsolete—contact Eaton	—	BA-800 723 kV mounting	—	—	—
30A6178G04	Obsolete—contact Eaton	—	BA-800 34.5 kV mounting	—	—	—
30A6178G05	Obsolete—contact Eaton	—	BA-800 live parts	—	—	—
30A6178G06	Obsolete—contact Eaton	—	BA-800 7.2 kV mounting	—	—	—
30A6178G07	Obsolete—contact Eaton	—	BA-800 14.4 kV mounting	—	—	—
30A6178G08	Obsolete—contact Eaton	—	BA-800 723 kV mounting	—	—	—
30A6178G09	Obsolete—contact Eaton	—	BA-800 34.5 kV mounting	—	—	—
310C095G01	Obsolete—contact Eaton	—	3 in dia. 2.4 kV 25E fuse	—	—	—
310C095G02	2CLE-50E	449D797G03	—	CLE	2.75	50E
310C095G03	2CLE-65E	449D797G04	—	CLE	2.75	65E
310C095G04	2CLE-80E	449D797G05	—	CLE	2.75	80E
310C095G05	2CLE-100E	449D797G06	—	CLE	2.75	100E
310C095G06	2CLE-125E	449D797G07	—	CLE	2.75	125E
310C095G07	2CLE-150E	449D797G08	—	CLE	2.75	150E
310C095G08	2CLE-200E	449D797G09	—	CLE	2.75	200E
310C095G10	2CLE-30E	449D797G02	—	CLE	2.75	30E
310C095G12	5CLE-50E	5981C65G02	—	CLE	5.5	50E
310C095G13	5CLE-65E	5981C65G03	—	CLE	5.5	65E
310C095G14	5CLE-80E	5981C65G04	—	CLE	5.5	80E
310C095G15	5CLE100E	5981C65G05	—	CLE	5.5	100E
310C095G16	5CLE-125E	5981C65G06	—	CLE	5.5	125E
310C095G17	5CLE-150E	5981C65G07	—	CLE	5.5	150E
310C095G18	5CLE-200E	5981C65G09	—	CLE	5.5	200E
310C095G19	Obsolete—contact Eaton	—	5CLE1-225E	—	—	—
310C095G20	5CLE-30E	5981C28G03	—	CLE	5.5	30E
310C095G21	5CLE-40E	5981C65G01	—	CLE	5.5	40E
—	8BA4-NH	310C196G01	—	BA4	8.3	400
—	15BA4-NH	310C196G02	—	BA4	15.5	400
310C131G01	8RDB4-DH	310C131G01	—	RDB4	8.3	400
310C131G02	15RDB4-DH	310C131G02	—	RDB4	15.5	400
310C131G03	25RDB4-DH	310C131G03	—	RDB4	25.5	300
310C131G04	38RDB4-DH	310C131G04	—	RDB4	38	300
310C132G01	RBA4-FLTR	309C024G04	—	RBA4	—	400

Appendix 2—Superseded Style Number Index

Old 10 Digit Style Number	Current Eaton Catalog Number	Eaton 10 Digit Style Number	Description	Type	Voltage Rating kV Max.	Current Rating Amperes
310C191A01	Obsolete—contact Eaton	—	BA-400 live parts	—	—	—
310C191A02	Obsolete—contact Eaton	—	BA-400 live parts—rear connected	—	—	—
310C191A03	Obsolete—contact Eaton	—	BA-400 live parts—rear connected	—	—	—
310C191A04	Obsolete—contact Eaton	—	BA-400 live parts—rear connected	—	—	—
310C192G01	Obsolete—contact Eaton	—	BA-400S fuse holder	—	—	—
310C192G02	Obsolete—contact Eaton	—	BA-400S fuse holder	—	—	—
310C192G03	Obsolete—contact Eaton	—	BA-400S fuse holder	—	—	—
310C192G04	Obsolete—contact Eaton	—	BA-400S fuse holder	—	—	—
310C196G01	8BA4-NH	310C196G01	—	BA4	8.3	400
310C196G02	15BA4-NH	310C196G02	—	BA4	15.5	400
310C196G03	Obsolete—contact Eaton	—	—	—	—	—
310C196G04	Obsolete—contact Eaton	—	—	—	—	—
310C197G03	RBA2-COND	310C197G03	(3 pack)	RBA2	—	200
310C197G04	RBA4-COND	310C197G04	(3 pack)	RBA4	—	400
310C197G05	RBA2-COND	310C197G05	(1 pack)	RBA2	—	200
310C197G06	RBA4-COND	310C197G06	(1 pack)	RBA4	—	400
310C198G01	8BA2-NH	310C198G01	—	BA2	8.3	200
310C198G02	15BA2-NH	310C198G02	—	BA2	15.5	200
310C198G03	Obsolete—contact Eaton	—	—	—	—	—
310C198G04	Obsolete—contact Eaton	—	—	—	—	—
310C392G01	Obsolete—contact Eaton	—	Special BA-400 fuse holder	—	—	—
310C392G02	Obsolete—contact Eaton	—	Special BA-400 fuse holder	—	—	—
310C658G02	5LCLS-2R	676C546G15	—	CLS	5.08	2R(70)
310C658G03	5LCLS-3R	676C546G16	—	CLS	5.08	3R(100)
310C658G04	5LCLS-4R	676C546G17	—	CLS	5.08	4R(130)
310C658G05	5LCLS-5R	676C546G18	—	CLS	5.08	5R(150)
310C658G06	5LCLS-6R	676C546G19	—	CLS	5.08	6R(170)
310C658G09	5LCLS-9R	676C546G22	—	CLS	5.08	9R(200)
310C658G12	5LCLS-12R	676C546G25	—	CLS	5.08	12R(230)
310C660G01	2CLS-18R	591C813G01	—	CLS	2.54	18R(390)
310C660G02	2CLS-24R	591C813G02	—	CLS	2.54	24R(450)
310C660G03	Obsolete—contact Eaton	—	Hermetically sealed 5LCLS-18R	—	—	—
310C660G04	Obsolete—contact Eaton	—	Hermetically sealed 5LCLS-24R	—	—	—
310C905G01	2CLE-250E	449D797G13	—	CLE	2.75	250E
310C905G03	2CLE-300E	449D797G14	—	CLE	2.75	300E
310C905G04	2CLE-350X	449D797G15	—	CLE	2.75	350X
310C905G06	2CLE-400X	449D797G17	—	CLE	2.75	400X
310C905G09	5CLE-250E	5981C65G10	—	CLE	5.5	250E
310C905G11	5CLE-300E	5981C67G01	—	CLE	5.5	300E
310C905G12	5CLE-350E	5981C67G02	—	CLE	5.5	350E
310C905G13	Obsolete—contact Eaton	—	5CLE2-365X	—	—	—
310C905G14	5CLE-400E	5981C67G03	—	CLE	5.5	400E
336C490G01	2CLS-12R	591C812G08	—	CLS	2.54	12R(230)
337A770G01	2CLS-2R	591C812G02	—	CLS	2.54	2R(70)
337A771G01	2CLS-4R	591C812G04	—	CLS	2.54	4R(130)
337A772G01	2CLS-6R	591C812G06	—	CLS	2.54	6R(170)
337A773G01	2CLS-9R	591C812G07	—	CLS	2.54	9R(200)
337A774G01	2CLS-12R	591C812G08	—	CLS	2.54	12R(230)
337A775G01	5CLS-2R	151D241G02	—	CLS	5.08	2R(70)
337A776G01	5CLS-4R	151D241G04	—	CLS	5.08	4R(130)
337A777G01	5CLS-6R	151D241G06	—	CLS	5.08	6R(170)
337A778G01	5CLS-9R	151D961G01	—	CLS	5.08	9R(200)
337A779G01	5CLS-12R	151D961G02	—	CLS	5.08	12R(230)

Appendix 2—Superseded Style Number Index

Old 10 Digit Style Number	Current Eaton Catalog Number	Eaton 10 Digit Style Number	Description	Type	Voltage Rating kV Max.	Current Rating Amperes
343D316A34	Obsolete—contact Eaton	—	25BT-15E	—	—	—
343D316A35	Obsolete—contact Eaton	—	25BT-20E	—	—	—
343D316A36	Obsolete—contact Eaton	—	25BT-25E	—	—	—
343D316A37	Obsolete—contact Eaton	—	25BT-30E	—	—	—
343D316A38	Obsolete—contact Eaton	—	25BT-40E	—	—	—
343D316A39	Obsolete—contact Eaton	—	25BT-50E	—	—	—
343D316A40	Obsolete—contact Eaton	—	25BT-65E	—	—	—
343D316A41	Obsolete—contact Eaton	—	25BT-80E	—	—	—
343D316A42	Obsolete—contact Eaton	—	25BT-100E	—	—	—
343D316A43	Obsolete—contact Eaton	—	25BT-125E	—	—	—
343D316A44	Obsolete—contact Eaton	—	25BT-150E	—	—	—
343D316A45	Obsolete—contact Eaton	—	25BT-200E	—	—	—
366C453G01	RBA2-FLTR	309C024G03	(3 pack)	RBA2	—	200
366C453G02	RBA4-FLTR	309C024G04	(3 pack)	RBA4	—	400
366C474G01	2CLS-2R	591C812G02	—	CLS	2.54	2R(70)
366C474G02	2CLS-4R	591C812G04	—	CLS	2.54	4R(130)
366C474G03	2CLS-6R	591C812G06	—	CLS	2.54	6R(170)
366C474G04	2CLS-9R	591C812G07	—	CLS	2.54	9R(200)
366C474G05	2CLS-12R	591C812G08	—	CLS	2.54	12R(230)
366C474G07	5CLS-2R	676C546G15	—	CLS	5.08	2R(70)
366C474G08	5CLS-4R	676C546G17	—	CLS	5.08	4R(130)
366C474G09	5CLS-6R	676C546G19	—	CLS	5.08	6R(170)
366C474G10	5CLS-9R	676C546G22	—	CLS	5.08	9R(200)
366C474G11	5CLS-12R	676C546G25	—	CLS	5.08	12R(230)
366C474G13	5CLS-2R	676C546G15	—	CLS	5.08	2R(70)
366C474G14	5CLS-4R	676C546G17	—	CLS	5.08	4R(130)
366C474G15	5CLS-6R	676C546G19	—	CLS	5.08	6R(170)
366C474G16	5CLS-9R	676C546G22	—	CLS	5.08	9R(200)
366C474G17	5CLS-12R	676C546G25	—	CLS	5.08	12R(230)
366C490G01	2CLS-12R	591C812G08	—	CLS	2.54	12R(230)
366C490G02	5CLS-12R	676C546G25	—	CLS	5.08	12R(230)
366C490G03	2CLS-12R	591C812G08	—	CLS	2.54	12R(230)
366C490G04	5CLS-12R	676C546G25	—	CLS	5.08	12R(230)
366C569G02	Obsolete	—	BA-200 50E fuse	—	—	—
366C569G03	Obsolete	—	BA-200 65E fuse	—	—	—
366C569G04	Obsolete	—	BA-200 80E fuse	—	—	—
366C569G05	Obsolete	—	BA-200 100E fuse	—	—	—
366C569G06	Obsolete	—	BA-200 125E fuse	—	—	—
366C569G07	Obsolete	—	BA-200 150E fuse	—	—	—
366C569G08	Obsolete	—	BA-200 200E fuse	—	—	—
390B923G01	2CLE-50E	449D797G03	—	CLE	2.75	50E
390B924G01	2CLE-65E	449D797G04	—	CLE	2.75	65E
390B925G01	2CLE-80E	449D797G05	—	CLE	2.75	80E
390B926G01	2CLE-100E	449D797G06	—	CLE	2.75	100E
390B927G01	2CLE-125E	449D797G07	—	CLE	2.75	125E
390B928G01	2CLE-150E	449D797G08	—	CLE	2.75	150E
390B929G01	2CLE-200E	449D797G09	—	CLE	2.75	200E
390B932G01	5CLE-50E	5981C65G02	—	CLE	5.5	50E
390B932G02	5CLE-65E	5981C65G03	—	CLE	5.5	65E
390B934G03	5CLE-80E	5981C65G04	—	CLE	5.5	80E
390B935G01	5CLE-100E	5981C65G05	—	CLE	5.5	100E
390B936G01	5CLE-125E	5981C65G06	—	CLE	5.5	125E
390B937G01	5CLE-150E	5981C65G07	—	CLE	5.5	150E

Appendix 2—Superseded Style Number Index

Old 10 Digit Style Number	Current Eaton Catalog Number	Eaton 10 Digit Style Number	Description	Type	Voltage Rating kV Max.	Current Rating Amperes
390B938G01	5CLE-200E	5981C65G09	—	CLE	5.5	200E
390B941G01	5CLE-50E	5981C65G02	—	CLE	5.5	50E
390B942G01	5CLE-65E	5981C65G03	—	CLE	5.5	65E
391B247G01	5CLE-25E	678C240G05	—	CLE	5.5	25E
391B271G01	2CLE-15E	678C240G01	—	CLE	2.75	15E
391B272G01	2CLE-25E	678C240G03	—	CLE	2.75	25E
391B273G01	5CLE-15E	678C240G04	—	CLE	5.5	15E
391B275G01	15CLE-25E	678C240G12	—	CLE	15.5	25E
414D224G01	Obsolete—contact Eaton	—	BA-200 mounting—4.8 kV	—	—	—
414D224G02	Obsolete—contact Eaton	—	BA-200 mounting—7.2 kV	—	—	—
414D224G03	Obsolete—contact Eaton	—	BA-200 mounting—13.8 kV	—	—	—
414D224G04	Obsolete—contact Eaton	—	BA-200 mounting—14.4 kV	—	—	—
414D224G05	Obsolete—contact Eaton	—	BA-200 mounting—23 kV	—	—	—
414D224G06	Obsolete—contact Eaton	—	BA-200 mounting—34.5 kV	—	—	—
414D224G07	Obsolete—contact Eaton	—	BA-200 mounting—4.8 kV	—	—	—
414D224G08	Obsolete—contact Eaton	—	BA-200 mounting—7.2 kV	—	—	—
414D224G09	Obsolete—contact Eaton	—	BA-200 mounting—13.8 kV	—	—	—
414D224G10	Obsolete—contact Eaton	—	BA-200 mounting—14.4 kV	—	—	—
414D224G11	Obsolete—contact Eaton	—	BA-200 mounting—23 kV	—	—	—
414D224G12	Obsolete—contact Eaton	—	BA-200 mounting—34.5 kV	—	—	—
414D224G13	Obsolete—contact Eaton	—	BA-200 mounting—4.8 kV	—	—	—
414D224G14	Obsolete—contact Eaton	—	BA-200 mounting—7.2 kV	—	—	—
414D224G15	Obsolete—contact Eaton	—	BA-200 mounting—13.8 kV	—	—	—
414D224G16	Obsolete—contact Eaton	—	BA-200 mounting—14.4 kV	—	—	—
414D224G17	Obsolete—contact Eaton	—	BA-200 mounting—23 kV	—	—	—
414D224G18	Obsolete—contact Eaton	—	BA-200 mounting—34.5 kV	—	—	—
414D225G01	Obsolete—contact Eaton	—	BA-200 mounting—4.8 kV	—	—	—
414D225G02	Obsolete—contact Eaton	—	BA-200 mounting—7.2 kV	—	—	—
414D225G03	Obsolete—contact Eaton	—	BA-200 mounting—13.8 kV	—	—	—
414D225G04	Obsolete—contact Eaton	—	BA-200 mounting—14.4 kV	—	—	—
414D225G05	Obsolete—contact Eaton	—	BA-200 mounting—23 kV	—	—	—
414D225G06	Obsolete—contact Eaton	—	BA-200 mounting—34.5 kV	—	—	—
414D225G07	Obsolete—contact Eaton	—	BA-200 mounting—4.8 kV	—	—	—
414D225G08	Obsolete—contact Eaton	—	BA-200 mounting—7.2 kV	—	—	—
414D225G09	Obsolete—contact Eaton	—	BA-200 mounting—13.8 kV	—	—	—
414D225G10	Obsolete—contact Eaton	—	BA-200 mounting—14.4 kV	—	—	—
414D225G11	Obsolete—contact Eaton	—	BA-200 mounting—4.8 kV	—	—	—
414D225G12	Obsolete—contact Eaton	—	BA-200 mounting—7.2 kV	—	—	—
414D225G13	Obsolete—contact Eaton	—	BA-200 mounting—13.8 kV	—	—	—
414D225G14	Obsolete—contact Eaton	—	BA-200 mounting—14.4 kV	—	—	—
414D225G15	Obsolete—contact Eaton	—	BA-200 mounting—4.8 kV	—	—	—
414D225G16	Obsolete—contact Eaton	—	BA-200 mounting—7.2 kV	—	—	—
414D225G17	Obsolete—contact Eaton	—	BA-200 mounting—13.8 kV	—	—	—
414D225G18	Obsolete—contact Eaton	—	BA-200 mounting—14.4 kV	—	—	—
414D226G01	Obsolete—contact Eaton	—	BA-400 mounting—4.8 kV	—	—	—
414D226G02	Obsolete—contact Eaton	—	BA-400 mounting—7.2 kV	—	—	—
414D226G03	Obsolete—contact Eaton	—	BA-400 mounting—13.8 kV	—	—	—
414D226G04	Obsolete—contact Eaton	—	BA-400 mounting—14.4 kV	—	—	—
414D226G05	Obsolete—contact Eaton	—	BA-400 mounting—23 kV	—	—	—
414D226G06	Obsolete—contact Eaton	—	BA-400 mounting—34.5 kV	—	—	—
414D226G07	Obsolete—contact Eaton	—	BA-400 mounting—4.8 kV	—	—	—
414D226G08	Obsolete—contact Eaton	—	BA-400 mounting—7.2 kV	—	—	—
414D226G09	Obsolete—contact Eaton	—	BA-400 mounting—13.8 kV	—	—	—

Appendix 2—Superseded Style Number Index

Old 10 Digit Style Number	Current Eaton Catalog Number	Eaton 10 Digit Style Number	Description	Type	Voltage Rating kV Max.	Current Rating Amperes
414D226G10	Obsolete—contact Eaton	—	BA-400 mounting—14.4 kV	—	—	—
414D226G11	Obsolete—contact Eaton	—	BA-400 mounting—23 kV	—	—	—
414D226G12	Obsolete—contact Eaton	—	BA-400 mounting—4.8 kV	—	—	—
414D226G13	Obsolete—contact Eaton	—	BA-400 mounting—7.2 kV	—	—	—
414D226G14	Obsolete—contact Eaton	—	BA-400 mounting—13.8 kV	—	—	—
414D226G15	Obsolete—contact Eaton	—	BA-400 mounting—14.4 kV	—	—	—
414D226G16	Obsolete—contact Eaton	—	BA-400 mounting—23 kV	—	—	—
414D226G17	Obsolete—contact Eaton	—	BA-400 mounting—4.8 kV	—	—	—
414D226G18	Obsolete—contact Eaton	—	BA-400 mounting—7.2 kV	—	—	—
414D226G19	Obsolete—contact Eaton	—	BA-400 mounting—13.8 kV	—	—	—
414D226G20	Obsolete—contact Eaton	—	BA-400 mounting—14.4 kV	—	—	—
414D226G21	Obsolete—contact Eaton	—	BA-400 mounting—23 kV	—	—	—
414D227G01	Obsolete—contact Eaton	—	BA-400 mounting—4.8 kV	—	—	—
414D227G02	Obsolete—contact Eaton	—	BA-400 mounting—7.2 kV	—	—	—
414D227G03	Obsolete—contact Eaton	—	BA-400 mounting—13.8 kV	—	—	—
414D227G04	Obsolete—contact Eaton	—	BA-400 mounting—14.4 kV	—	—	—
414D227G05	Obsolete—contact Eaton	—	BA-400 mounting—23 kV	—	—	—
414D227G06	Obsolete—contact Eaton	—	BA-400 mounting—34.5 kV	—	—	—
414D227G07	Obsolete—contact Eaton	—	BA-400 mounting—4.8 kV	—	—	—
414D227G08	Obsolete—contact Eaton	—	BA-400 mounting—7.2 kV	—	—	—
414D227G09	Obsolete—contact Eaton	—	BA-400 mounting—13.8 kV	—	—	—
414D227G10	Obsolete—contact Eaton	—	BA-400 mounting—14.4 kV	—	—	—
414D227G11	Obsolete—contact Eaton	—	BA-400 mounting—23 kV	—	—	—
414D227G12	Obsolete—contact Eaton	—	BA-400 mounting—4.8 kV	—	—	—
414D227G13	Obsolete—contact Eaton	—	BA-400 mounting—7.2 kV	—	—	—
414D227G14	Obsolete—contact Eaton	—	BA-400 mounting—13.8 kV	—	—	—
414D227G15	Obsolete—contact Eaton	—	BA-400 mounting—14.4 kV	—	—	—
414D227G16	Obsolete—contact Eaton	—	BA-400 mounting—23 kV	—	—	—
414D227G17	Obsolete—contact Eaton	—	BA-400 mounting—4.8 kV	—	—	—
414D227G18	Obsolete—contact Eaton	—	BA-400 mounting—7.2 kV	—	—	—
414D227G19	Obsolete—contact Eaton	—	BA-400 mounting—13.8 kV	—	—	—
414D227G20	Obsolete—contact Eaton	—	BA-400 mounting—14.4 kV	—	—	—
414D227G21	Obsolete—contact Eaton	—	BA-400 mounting—23 kV	—	—	—
418D565G31	5CLE-200E	5981G65G09	—	CLE	5.5	200E
421D701G17	8CLE-80E	5981C17G06	—	CLE	8.3	80E
421D701G19	8CLE-100E	5981C17G07	—	CLE	8.3	100E
421D701G25	15CLE-80E	5981C19G07	—	CLE	15.5	80E
421D701G26	15CLE-100E	5981C19G08	—	CLE	15.5	100E
422D324G01	Obsolete—contact Eaton	—	BA-800 mounting—4.8 kV	—	—	—
422D324G02	Obsolete—contact Eaton	—	BA-800 mounting—4.8 kV	—	—	—
422D324G03	Obsolete—contact Eaton	—	BA-800 mounting—4.8 kV	—	—	—
422D324G04	Obsolete—contact Eaton	—	BA-800 mounting—4.8 kV	—	—	—
422D324G05	Obsolete—contact Eaton	—	BA-800 mounting—7.2 kV	—	—	—
422D324G06	Obsolete—contact Eaton	—	BA-800 mounting—7.2 kV	—	—	—
422D324G07	Obsolete—contact Eaton	—	BA-800 mounting—7.2 kV	—	—	—
422D324G08	Obsolete—contact Eaton	—	BA-800 mounting—7.2 kV	—	—	—
422D324G09	Obsolete—contact Eaton	—	BA-800 mounting—13.2 kV	—	—	—
422D324G10	Obsolete—contact Eaton	—	BA-800 mounting—13.2 kV	—	—	—
422D324G11	Obsolete—contact Eaton	—	BA-800 mounting—13.2 kV	—	—	—
422D324G12	Obsolete—contact Eaton	—	BA-800 mounting—13.2 kV	—	—	—
422D324G13	Obsolete—contact Eaton	—	BA-800 mounting—14.4 kV	—	—	—
422D324G14	Obsolete—contact Eaton	—	BA-800 mounting—14.4 kV	—	—	—
422D324G15	Obsolete—contact Eaton	—	BA-800 mounting—14.4 kV	—	—	—

Appendix 2—Superseded Style Number Index

Old 10 Digit Style Number	Current Eaton Catalog Number	Eaton 10 Digit Style Number	Description	Type	Voltage Rating kV Max.	Current Rating Amperes
422D324G16	Obsolete—contact Eaton	—	BA-800 mounting—14.4 kV	—	—	—
423D769G01	Obsolete—contact Eaton	—	8BA2-MODH	—	—	—
423D769G02	Obsolete—contact Eaton	—	15BA2-MODH	—	—	—
423D769G03	Obsolete—contact Eaton	—	25BA2-MODH	—	—	—
423D769G04	Obsolete—contact Eaton	—	48BA2-MODH	—	—	—
423D769G05	Obsolete—contact Eaton	—	8BA2-75VODH	—	—	—
423D769G06	Obsolete—contact Eaton	—	15BA2-75VODH	—	—	—
423D769G07	Obsolete—contact Eaton	—	25BA2-75VODH	—	—	—
423D769G08	Obsolete—contact Eaton	—	48BA2-75VODH	—	—	—
423D769G09	Obsolete—contact Eaton	—	8BA2-180VODH	—	—	—
423D769G10	Obsolete—contact Eaton	—	15BA2-180VODH	—	—	—
423D769G11	Obsolete—contact Eaton	—	25BA2-180VODH	—	—	—
423D769G12	Obsolete—contact Eaton	—	48BA2-180VODH	—	—	—
423D770G01	Obsolete—contact Eaton	—	8BA4-MODH	—	—	—
423D770G02	Obsolete—contact Eaton	—	15BA4-MODH	—	—	—
423D770G03	Obsolete—contact Eaton	—	25BA4-MODH	—	—	—
423D770G04	Obsolete—contact Eaton	—	48BA4-MODH	—	—	—
423D770G05	Obsolete—contact Eaton	—	8BA4-75VODH	—	—	—
423D770G06	Obsolete—contact Eaton	—	15BA4-75VODH	—	—	—
423D770G07	Obsolete—contact Eaton	—	25BA4-75VODH	—	—	—
423D770G08	Obsolete—contact Eaton	—	48BA4-75VODH	—	—	—
423D770G09	Obsolete—contact Eaton	—	8BA4-180VODH	—	—	—
423D770G10	Obsolete—contact Eaton	—	15BA4-180VODH	—	—	—
423D770G11	Obsolete—contact Eaton	—	25BA4-180VODH	—	—	—
423D770G12	Obsolete—contact Eaton	—	48BA4-180VODH	—	—	—
423D814A05	8RBA2-10E	423D814A05	—	RBA2	8.3	10E
423D814A06	8RBA2-15E	423D814A06	—	RBA2	8.3	15E
423D814A07	8RBA2-20E	423D814A07	—	RBA2	8.3	20E
423D814A08	8RBA2-25E	423D814A08	—	RBA2	8.3	25E
423D814A09	8RBA2-30E	423D814A09	—	RBA2	8.3	30E
423D814A10	8RBA2-40E	423D814A10	—	RBA2	8.3	40E
423D814A11	8RBA2-50E	423D814A11	—	RBA2	8.3	50E
423D814A12	8RBA2-65E	423D814A12	—	RBA2	8.3	65E
423D814A13	8RBA2-80E	423D814A13	—	RBA2	8.3	80E
423D814A14	8RBA2-100E	423D814A14	—	RBA2	8.3	100E
423D814A15	8RBA2-125E	423D814A15	—	RBA2	8.3	125E
423D814A16	8RBA2-150E	423D814A16	—	RBA2	8.3	150E
423D814A17	8RBA2-175E	423D814A17	—	RBA2	8.3	175E
423D814A18	8RBA2-200E	423D814A18	—	RBA2	8.3	200E
423D814A19	15RBA2-10E	423D814A19	—	RBA2	15.5	10E
423D814A20	15RBA2-15E	423D814A20	—	RBA2	15.5	15E
423D814A21	15RBA2-20E	423D814A21	—	RBA2	15.5	20E
423D814A22	15RBA2-25E	423D814A22	—	RBA2	15.5	25E
423D814A23	15RBA2-30E	423D814A23	—	RBA2	15.5	30E
423D814A24	15RBA2-40E	423D814A24	—	RBA2	15.5	40E
423D814A25	15RBA2-50E	423D814A25	—	RBA2	15.5	50E
423D814A26	15RBA2-65E	423D814A26	—	RBA2	15.5	65E
423D814A27	15RBA2-150E	423D814A27	—	RBA2	15.5	80E
423D814A28	15RBA2-100E	423D814A28	—	RBA2	15.5	100E
423D814A29	15RBA2-125E	423D814A29	—	RBA2	15.5	125E
423D814A30	15RBA2-150E	423D814A30	—	RBA2	15.5	150E
423D814A31	15RBA2-175E	423D814A31	—	RBA2	15.5	175E
423D814A32	15RBA2-200E	423D814A32	—	RBA2	15.5	200E

Appendix 2—Superseded Style Number Index

Old 10 Digit Style Number	Current Eaton Catalog Number	Eaton 10 Digit Style Number	Description	Type	Voltage Rating kV Max.	Current Rating Amperes
423D814A33	25RBA2-10E	423D814A33	—	RBA2	25.5	10E
423D814A34	25RBA2-15E	423D814A34	—	RBA2	25.5	15E
423D814A35	25RBA2-20E	423D814A35	—	RBA2	25.5	20E
423D814A36	25RBA2-25E	423D814A36	—	RBA2	25.5	25E
423D814A37	25RBA2-30E	423D814A37	—	RBA2	25.5	30E
423D814A38	25RBA2-40E	423D814A38	—	RBA2	25.5	40E
423D814A39	25RBA2-50E	423D814A39	—	RBA2	25.5	50E
423D814A40	25RBA2-65E	423D814A40	—	RBA2	25.5	65E
423D814A41	25RBA2-250E	423D814A41	—	RBA2	25.5	80E
423D814A42	25RBA2-100E	423D814A42	—	RBA2	25.5	100E
423D814A43	25RBA2-125E	423D814A43	—	RBA2	25.5	125E
423D814A44	25RBA2-150E	423D814A44	—	RBA2	25.5	150E
423D814A45	25RBA2-175E	423D814A45	—	RBA2	25.5	175E
423D814A46	25RBA2-200E	423D814A46	—	RBA2	25.5	200E
423D814A47	38RBA2-10E	423D814A47	—	RBA2	38	10E
423D814A48	38RBA2-15E	423D814A48	—	RBA2	38	15E
423D814A49	38RBA2-20E	423D814A49	—	RBA2	38	20E
423D814A50	38RBA2-25E	423D814A50	—	RBA2	38	25E
423D814A51	38RBA2-30E	423D814A51	—	RBA2	38	30E
423D814A52	38RBA2-40E	423D814A52	—	RBA2	38	40E
423D814A53	38RBA2-50E	423D814A53	—	RBA2	38	50E
423D814A54	38RBA2-65E	423D814A54	—	RBA2	38	65E
423D814A55	38RBA2-380E	423D814A55	—	RBA2	38	80E
423D814A56	38RBA2-100E	423D814A56	—	RBA2	38	100E
423D814A57	38RBA2-125E	423D814A57	—	RBA2	38	125E
423D814A58	38RBA2-150E	423D814A58	—	RBA2	38	150E
423D814A59	38RBA2-175E	423D814A59	—	RBA2	38	175E
423D814A60	38RBA2-200E	423D814A60	—	RBA2	38	200E
423D815A01	8RBA4-.5E	5982C44G01	—	RBA4	8.3	0.5
423D815A02	8RBA4-3E	5982C44G02	—	RBA4	8.3	3
423D815A03	8RBA4-5E	5982C44G03	—	RBA4	8.3	5E
423D815A04	8RBA4-7E	5982C44G04	—	RBA4	8.3	7E
423D815A05	8RBA4-10E	5982C44G05	—	RBA4	8.3	10E
423D815A06	8RBA4-15E	5982C44G06	—	RBA4	8.3	15E
423D815A07	8RBA4-20E	5982C44G07	—	RBA4	8.3	20E
423D815A08	8RBA4-25E	5982C44G08	—	RBA4	8.3	25E
423D815A09	8RBA4-30E	5982C44G09	—	RBA4	8.3	30E
423D815A10	8RBA4-40E	5982C44G10	—	RBA4	8.3	40E
423D815A11	8RBA4-50E	5982C44G11	—	RBA4	8.3	50E
423D815A12	8RBA4-65E	5982C44G12	—	RBA4	8.3	65E
423D815A13	8RBA4-80E	5982C44G13	—	RBA4	8.3	80E
423D815A14	8RBA4-100E	5982C44G14	—	RBA4	8.3	100E
423D815A15	8RBA4-125E	5982C44G15	—	RBA4	8.3	125E
423D815A16	8RBA4-150E	5982C44G16	—	RBA4	8.3	150E
423D815A17	8RBA4-175E	5982C44G17	—	RBA4	8.3	175E
423D815A18	8RBA4-200E	5982C44G18	—	RBA4	8.3	200E
423D815A19	8RBA4-250E	5982C44G19	—	RBA4	8.3	250E
423D815A20	8RBA4-300E	5982C44G20	—	RBA4	8.3	300E
423D815A22	8RBA4-400E	5982C44G22	—	RBA4	8.3	400E
423D815A26	15RBA4-.5E	5982C44G26	—	RBA4	15.5	0.5
423D815A27	15RBA4-3E	5982C44G27	—	RBA4	15.5	3
423D815A28	15RBA4-5E	5982C44G28	—	RBA4	15.5	5E
423D815A29	15RBA4-7E	5982C44G29	—	RBA4	15.5	7E

Appendix 2—Superseded Style Number Index

Old 10 Digit Style Number	Current Eaton Catalog Number	Eaton 10 Digit Style Number	Description	Type	Voltage Rating kV Max.	Current Rating Amperes
423D815A30	15RBA4-10E	5982C44G30	—	RBA4	15.5	10E
423D815A31	15RBA4-15E	5982C44G31	—	RBA4	15.5	15E
423D815A32	15RBA4-20E	5982C44G32	—	RBA4	15.5	20E
423D815A33	15RBA4-25E	5982C44G33	—	RBA4	15.5	25E
423D815A34	15RBA4-30E	5982C44G34	—	RBA4	15.5	30E
423D815A35	15RBA4-40E	5982C44G35	—	RBA4	15.5	40E
423D815A36	15RBA4-50E	5982C44G36	—	RBA4	15.5	50E
423D815A37	15RBA4-65E	5982C44G37	—	RBA4	15.5	65E
423D815A38	15RBA4-80E	5982C44G38	—	RBA4	15.5	80E
423D815A39	15RBA4-100E	5982C44G39	—	RBA4	15.5	100E
423D815A40	15RBA4-125E	5982C44G40	—	RBA4	15.5	125E
423D815A41	15RBA4-150E	5982C44G41	—	RBA4	15.5	150E
423D815A42	15RBA4-175E	5982C44G42	—	RBA4	15.5	175E
423D815A43	15RBA4-200E	5982C44G43	—	RBA4	15.5	200E
423D815A44	15RBA4-250E	5982C44G44	—	RBA4	15.5	250E
423D815A45	15RBA4-300E	5982C44G45	—	RBA4	15.5	300E
423D815A47	15RBA4-400E	5982C44G47	—	RBA4	15.5	400E
423D815A51	25RBA4-.5E	5982C44G51	—	RBA4	25.5	0.5
423D815A52	25RBA4-3E	5982C44G52	—	RBA4	25.5	3
423D815A53	25RBA4-5E	5982C44G53	—	RBA4	25.5	5E
423D815A54	25RBA4-7E	5982C44G54	—	RBA4	25.5	7E
423D815A55	25RBA4-10E	5982C44G55	—	RBA4	25.5	10E
423D815A56	25RBA4-15E	5982C44G56	—	RBA4	25.5	15E
423D815A57	25RBA4-20E	5982C44G57	—	RBA4	25.5	20E
423D815A58	25RBA4-25E	5982C44G58	—	RBA4	25.5	25E
423D815A59	25RBA4-30E	5982C44G59	—	RBA4	25.5	30E
423D815A60	25RBA4-40E	5982C44G60	—	RBA4	25.5	40E
423D815A61	25RBA4-50E	5982C44G61	—	RBA4	25.5	50E
423D815A62	25RBA4-65E	5982C44G62	—	RBA4	25.5	65E
423D815A63	25RBA4-80E	5982C44G63	—	RBA4	25.5	80E
423D815A64	25RBA4-100E	5982C44G64	—	RBA4	25.5	100E
423D815A65	25RBA4-125E	5982C44G65	—	RBA4	25.5	125E
423D815A66	25RBA4-150E	5982C44G66	—	RBA4	25.5	150E
423D815A67	25RBA4-175E	5982C44G67	—	RBA4	25.5	175E
423D815A68	25RBA4-200E	5982C44G68	—	RBA4	25.5	200E
423D815A69	25RBA4-250E	5982C44G69	—	RBA4	25.5	250E
423D815A70	25RBA4-300E	5982C44G70	—	RBA4	25.5	300E
423D815A76	38RBA4-.5E	5982C44G76	—	RBA4	38	0.5
423D815A77	38RBA4-3E	5982C44G77	—	RBA4	38	3
423D815A78	38RBA4-5E	5982C44G78	—	RBA4	38	5E
423D815A79	38RBA4-7E	5982C44G79	—	RBA4	38	7E
423D815A80	38RBA4-10E	5982C44G80	—	RBA4	38	10E
423D815A81	38RBA4-15E	5982C44G81	—	RBA4	38	15E
423D815A82	38RBA4-20E	5982C44G82	—	RBA4	38	20E
423D815A83	38RBA4-25E	5982C44G83	—	RBA4	38	25E
423D815A84	38RBA4-30E	5982C44G84	—	RBA4	38	30E
423D815A85	38RBA4-40E	5982C44G85	—	RBA4	38	40E
423D815A86	38RBA4-50E	5982C44G86	—	RBA4	38	50E
423D815A87	38RBA4-65E	5982C44G87	—	RBA4	38	65E
423D815A88	38RBA4-80E	5982C44G88	—	RBA4	38	80E
423D815A89	38RBA4-100E	5982C44G89	—	RBA4	38	100E
423D815A90	38RBA4-125E	5982C44G90	—	RBA4	38	125E
423D815A91	38RBA4-150E	5982C44G91	—	RBA4	38	150E

Appendix 2—Superseded Style Number Index

Old 10 Digit Style Number	Current Eaton Catalog Number	Eaton 10 Digit Style Number	Description	Type	Voltage Rating kV Max.	Current Rating Amperes
423D815A92	38RBA4-175E	5982C44G92	—	RBA4	38	175E
423D815A93	38RBA4-200E	5982C44G93	—	RBA4	38	200E
423D815A94	38RBA4-250E	5982C44G94	—	RBA4	38	250E
423D815A95	38RBA4-300E	5982C44G95	—	RBA4	38	300E
423D816G01	Obsolete—contact Eaton	—	BA-200 mounting—4.8 kV	—	—	—
423D816G02	Obsolete—contact Eaton	—	BA-200 mounting—4.8 kV	—	—	—
423D816G03	Obsolete—contact Eaton	—	BA-200 mounting—4.8 kV	—	—	—
423D816G04	Obsolete—contact Eaton	—	BA-200 mounting—4.8 kV	—	—	—
423D816G05	Obsolete—contact Eaton	—	BA-200 mounting—7.2 kV	—	—	—
423D816G06	Obsolete—contact Eaton	—	BA-200 mounting—7.2 kV	—	—	—
423D816G07	Obsolete—contact Eaton	—	BA-200 mounting—7.2 kV	—	—	—
423D816G08	Obsolete—contact Eaton	—	BA-200 mounting—7.2 kV	—	—	—
423D816G09	Obsolete—contact Eaton	—	BA-200 mounting—13.2 kV	—	—	—
423D816G10	Obsolete—contact Eaton	—	BA-200 mounting—13.2 kV	—	—	—
423D816G11	Obsolete—contact Eaton	—	BA-200 mounting—13.2 kV	—	—	—
423D816G12	Obsolete—contact Eaton	—	BA-200 mounting—13.2 kV	—	—	—
423D816G13	Obsolete—contact Eaton	—	BA-200 mounting—14.4 kV	—	—	—
423D816G14	Obsolete—contact Eaton	—	BA-200 mounting—14.4 kV	—	—	—
423D816G15	Obsolete—contact Eaton	—	BA-200 mounting—14.4 kV	—	—	—
423D816G16	Obsolete—contact Eaton	—	BA-200 mounting—14.4 kV	—	—	—
423D816G17	Obsolete—contact Eaton	—	BA-200 mounting—23 kV	—	—	—
423D816G21	Obsolete—contact Eaton	—	BA-200 mounting—134.5 kV	—	—	—
423D885G01	Obsolete—contact Eaton	—	BA-400 mounting—4.8 kV	—	—	—
423D885G02	Obsolete—contact Eaton	—	BA-400 mounting—4.8 kV	—	—	—
423D885G03	Obsolete—contact Eaton	—	BA-400 mounting—4.8 kV	—	—	—
423D885G04	Obsolete—contact Eaton	—	BA-400 mounting—4.8 kV	—	—	—
423D885G05	Obsolete—contact Eaton	—	BA-400 mounting—7.2 kV	—	—	—
423D885G06	Obsolete—contact Eaton	—	BA-400 mounting—7.2 kV	—	—	—
423D885G07	Obsolete—contact Eaton	—	BA-400 mounting—7.2 kV	—	—	—
423D885G08	Obsolete—contact Eaton	—	BA-400 mounting—7.2 kV	—	—	—
423D885G09	Obsolete—contact Eaton	—	BA-400 mounting—13.2 kV	—	—	—
423D885G10	Obsolete—contact Eaton	—	BA-400 mounting—13.2 kV	—	—	—
423D885G11	Obsolete—contact Eaton	—	BA-400 mounting—13.2 kV	—	—	—
423D885G12	Obsolete—contact Eaton	—	BA-400 mounting—13.2 kV	—	—	—
423D885G13	Obsolete—contact Eaton	—	BA-400 mounting—14.4 kV	—	—	—
423D885G14	Obsolete—contact Eaton	—	BA-400 mounting—14.4 kV	—	—	—
423D885G15	Obsolete—contact Eaton	—	BA-400 mounting—14.4 kV	—	—	—
423D885G16	Obsolete—contact Eaton	—	BA-400 mounting—14.4 kV	—	—	—
42A4072G21	Obsolete—contact Eaton	—	38DBA5-.5E	—	—	—
42A4072G23	Obsolete—contact Eaton	—	38DBA5-5E	—	—	—
42A4072G24	Obsolete—contact Eaton	—	38DBA5-7E	—	—	—
42A4072G25	Obsolete—contact Eaton	—	38DBA5-10E	—	—	—
42A4072G26	Obsolete—contact Eaton	—	38DBA5-15E	—	—	—
42A4072G27	Obsolete—contact Eaton	—	38DBA5-20E	—	—	—
42A4072G28	Obsolete—contact Eaton	—	38DBA5-25E	—	—	—
42A4072G29	Obsolete—contact Eaton	—	38DBA5-30E	—	—	—
42A4072G30	Obsolete—contact Eaton	—	38DBA5-40E	—	—	—
42A4072G31	Obsolete—contact Eaton	—	38DBA5.50E	—	—	—
42A4072G32	Obsolete—contact Eaton	—	38DBA5-65E	—	—	—
42A4072G33	Obsolete—contact Eaton	—	38DBA5-80E	—	—	—
42A4072G34	Obsolete—contact Eaton	—	38DBA5-100E	—	—	—
42A4072G35	Obsolete—contact Eaton	—	38DBA5-125E	—	—	—
42A4072G36	Obsolete—contact Eaton	—	38DBA5-150E	—	—	—

Appendix 2—Superseded Style Number Index

Old 10 Digit Style Number	Current Eaton Catalog Number	Eaton 10 Digit Style Number	Description	Type	Voltage Rating kV Max.	Current Rating Amperes
42A4072G37	Obsolete—contact Eaton	—	38DBA5-200E	—	—	—
42A4072G41	Obsolete—contact Eaton	—	48DBA5-.5E	—	—	—
42A4072G43	Obsolete—contact Eaton	—	48DBA5-5E	—	—	—
42A4072G44	Obsolete—contact Eaton	—	48DBA5-7E	—	—	—
42A4072G45	Obsolete—contact Eaton	—	48DBA5-10E	—	—	—
42A4072G46	Obsolete—contact Eaton	—	48DBA5-15E	—	—	—
42A4072G47	Obsolete—contact Eaton	—	48DBA5-20E	—	—	—
42A4072G48	Obsolete—contact Eaton	—	48DBA5-25E	—	—	—
42A4072G49	Obsolete—contact Eaton	—	48DBA5-30E	—	—	—
42A4072G50	Obsolete—contact Eaton	—	48DBA5-40E	—	—	—
42A4072G51	Obsolete—contact Eaton	—	48DBA5.50E	—	—	—
42A4072G52	Obsolete—contact Eaton	—	48DBA5-65E	—	—	—
42A4072G53	Obsolete—contact Eaton	—	48DBA5-80E	—	—	—
42A4072G54	Obsolete—contact Eaton	—	48DBA5-100E	—	—	—
42A4072G55	Obsolete—contact Eaton	—	48DBA5-125E	—	—	—
42A4072G56	Obsolete—contact Eaton	—	48DBA5-150E	—	—	—
42A4072G57	Obsolete—contact Eaton	—	48DBA5-200E	—	—	—
42A4072G61	Obsolete—contact Eaton	—	72DBA5-.5E	—	—	—
42A4072G63	Obsolete—contact Eaton	—	72DBA5-5E	—	—	—
42A4072G64	Obsolete—contact Eaton	—	72DBA5-7E	—	—	—
42A4072G65	Obsolete—contact Eaton	—	72DBA5-10E	—	—	—
42A4072G66	Obsolete—contact Eaton	—	72DBA5-15E	—	—	—
42A4072G67	Obsolete—contact Eaton	—	72DBA5-20E	—	—	—
42A4072G68	Obsolete—contact Eaton	—	72DBA5-25E	—	—	—
42A4072G69	Obsolete—contact Eaton	—	72DBA5-30E	—	—	—
42A4072G70	Obsolete—contact Eaton	—	72DBA5-40E	—	—	—
42A4072G71	Obsolete—contact Eaton	—	72DBA5.50E	—	—	—
42A4072G72	Obsolete—contact Eaton	—	72DBA5-65E	—	—	—
42A4072G73	Obsolete—contact Eaton	—	72DBA5-80E	—	—	—
42A4072G74	Obsolete—contact Eaton	—	72DBA5-100E	—	—	—
42A4072G75	Obsolete—contact Eaton	—	72DBA5-125E	—	—	—
42A4072G76	Obsolete—contact Eaton	—	72DBA5-150E	—	—	—
42A4072G77	Obsolete—contact Eaton	—	72DBA5-200E	—	—	—
431B345G01	2CLE-20E	678C240G02	—	CLE	2.75	20E
431B346G01	5CLE-20E	678C240G05	—	CLE	5.5	20E
431B347G01	8CLE-15E	678C240G07	—	CLE	8.3	15E
431B348G01	8CLE-20E	678C240G08	—	CLE	8.3	20E
431B349G01	8CLE-25E	678C240G09	—	CLE	8.3	25E
431B350G01	15CLE-15E	678C240G10	—	CLE	15.5	15E
431B351G01	15CLE-20E	678C240G11	—	CLE	15.5	20E
431B373G01	15CLE-50E	678C240G12	—	CLE	15.5	25E
431B374G09	15CLE-65E	5981C19G06	—	CLE	15.5	65E
432D140A02	2CLE-PDM-D	9078A65G15	—	CLE	2.75	250
432D140A04	2CLE-PDM-D	9078A65G15	—	CLE	2.75	250
432D140A05	5CLE-PDM-D	9078A65G16	—	CLE	5.5	250
432D140A06	8CLE-PDM-D	9078A65G17	—	CLE	8.3	175
432D140A07	2CLE-PDM-D	9078A65G15	—	CLE	2.75	250
432D140A10	15CLE-PDM-D	9078A65G18	—	CLE	15.5	150
432D140A11	15CLE-HPDM-D	9078A65G19	—	CLE	15.5	150
432D140A13	Obsolete—contact Eaton	—	Rear connected disconnect CLE mountings	—	—	—
432D140A15	Obsolete—contact Eaton	—	Rear connected disconnect CLE mountings	—	—	—
432D140A16	Obsolete—contact Eaton	—	Rear connected disconnect CLE mountings	—	—	—
432D140A20	Obsolete—contact Eaton	—	Rear connected disconnect CLE mountings	—	—	—

Appendix 2—Superseded Style Number Index

Old 10 Digit Style Number	Current Eaton Catalog Number	Eaton 10 Digit Style Number	Description	Type	Voltage Rating kV Max.	Current Rating Amperes
432D140A21	Obsolete—contact Eaton	—	Rear connected disconnect CLE mountings	—	—	—
432D140A23	Obsolete—contact Eaton	—	Rear connected disconnect CLE mountings	—	—	—
432D140A25	Obsolete—contact Eaton	—	Rear connected disconnect CLE mountings	—	—	—
432D140A26	Obsolete—contact Eaton	—	Rear connected disconnect CLE mountings	—	—	—
432D140A30	Obsolete—contact Eaton	—	Rear connected disconnect CLE mountings	—	—	—
432D140A31	Obsolete—contact Eaton	—	Rear connected disconnect CLE mountings	—	—	—
432D140A33	Obsolete—contact Eaton	—	Rear connected disconnect CLE mountings	—	—	—
432D140A35	Obsolete—contact Eaton	—	Rear connected disconnect CLE mountings	—	—	—
432D140A36	Obsolete—contact Eaton	—	Rear connected disconnect CLE mountings	—	—	—
432D140A40	Obsolete—contact Eaton	—	Rear connected disconnect CLE mountings	—	—	—
432D140A41	Obsolete—contact Eaton	—	Rear connected disconnect CLE mountings	—	—	—
432D886G06	2CLE-250E	449D797G13	—	CLE	2.75	250E
432D886G14	5CLE-250E	5981C65G10	—	CLE	5.5	250E
434D316A04	Obsolete—contact Eaton	—	8BT2-15E	—	—	—
434D316A05	Obsolete—contact Eaton	—	8BT2-20E	—	—	—
434D316A06	Obsolete—contact Eaton	—	8BT2-25E	—	—	—
434D316A07	Obsolete—contact Eaton	—	8BT2-30E	—	—	—
434D316A08	Obsolete—contact Eaton	—	8BT2-40E	—	—	—
434D316A09	Obsolete—contact Eaton	—	8BT2-50E	—	—	—
434D316A10	Obsolete—contact Eaton	—	8BT2-65E	—	—	—
434D316A11	Obsolete—contact Eaton	—	8BT2-80E	—	—	—
434D316A12	Obsolete—contact Eaton	—	8BT2-100E	—	—	—
434D316A13	Obsolete—contact Eaton	—	8BT2-125E	—	—	—
434D316A14	Obsolete—contact Eaton	—	8BT2-150E	—	—	—
434D316A15	Obsolete—contact Eaton	—	8BT2-200E	—	—	—
434D316A19	Obsolete—contact Eaton	—	15BT2-15E	—	—	—
434D316A20	Obsolete—contact Eaton	—	15BT2-20E	—	—	—
434D316A21	Obsolete—contact Eaton	—	15BT2-25E	—	—	—
434D316A22	Obsolete—contact Eaton	—	15BT2-30E	—	—	—
434D316A23	Obsolete—contact Eaton	—	15BT2-40E	—	—	—
434D316A24	Obsolete—contact Eaton	—	15BT2-50E	—	—	—
434D316A25	Obsolete—contact Eaton	—	15BT2-65E	—	—	—
434D316A26	Obsolete—contact Eaton	—	15BT2-80E	—	—	—
434D316A27	Obsolete—contact Eaton	—	15BT2-100E	—	—	—
434D316A28	Obsolete—contact Eaton	—	15BT2-125E	—	—	—
434D316A29	Obsolete—contact Eaton	—	15BT2-150E	—	—	—
434D316A30	Obsolete—contact Eaton	—	15BT2-200E	—	—	—
434D316A34	Obsolete—contact Eaton	—	25BT2-15E	—	—	—
434D316A35	Obsolete—contact Eaton	—	25BT2-20E	—	—	—
434D316A36	Obsolete—contact Eaton	—	25BT2-25E	—	—	—
434D316A37	Obsolete—contact Eaton	—	25BT2-30E	—	—	—
434D316A48	Obsolete—contact Eaton	—	25BT2-40E	—	—	—
434D316A39	Obsolete—contact Eaton	—	25BT2-50E	—	—	—
434D316A40	Obsolete—contact Eaton	—	25BT2-65E	—	—	—
434D316A41	Obsolete—contact Eaton	—	25BT2-80E	—	—	—
434D316A42	Obsolete—contact Eaton	—	25BT2-100E	—	—	—
434D316A43	Obsolete—contact Eaton	—	25BT2-125E	—	—	—
434D316A44	Obsolete—contact Eaton	—	25BT2-150E	—	—	—
434D316A45	Obsolete—contact Eaton	—	25BT2-200E	—	—	—
434D316A49	Obsolete—contact Eaton	—	38BT2-15E	—	—	—
434D316A50	Obsolete—contact Eaton	—	38BT2-20E	—	—	—
434D316A51	Obsolete—contact Eaton	—	38BT2-25E	—	—	—
434D316A52	Obsolete—contact Eaton	—	38BT2-30E	—	—	—

Appendix 2—Superseded Style Number Index

Old 10 Digit Style Number	Current Eaton Catalog Number	Eaton 10 Digit Style Number	Description	Type	Voltage Rating kV Max.	Current Rating Amperes
434D316A53	Obsolete—contact Eaton	—	38BT2-40E	—	—	—
434D316A54	Obsolete—contact Eaton	—	38BT2-50E	—	—	—
434D316A55	Obsolete—contact Eaton	—	38BT2-65E	—	—	—
434D316A56	Obsolete—contact Eaton	—	38BT2-80E	—	—	—
434D316A57	Obsolete—contact Eaton	—	38BT2-100E	—	—	—
434D316A58	Obsolete—contact Eaton	—	38BT2-125E	—	—	—
434D316A59	Obsolete—contact Eaton	—	38BT2-150E	—	—	—
434D316A60	Obsolete—contact Eaton	—	38BT2-200E	—	—	—
434D317A05	Obsolete—contact Eaton	—	8BT4-20E	—	—	—
434D317A06	Obsolete—contact Eaton	—	8BT4-25E	—	—	—
434D317A07	Obsolete—contact Eaton	—	8BT4-30E	—	—	—
434D317A08	Obsolete—contact Eaton	—	8BT4-40E	—	—	—
434D317A09	Obsolete—contact Eaton	—	8BT4-50E	—	—	—
434D317A10	Obsolete—contact Eaton	—	8BT4-65E	—	—	—
434D317A11	Obsolete—contact Eaton	—	8BT4-80E	—	—	—
434D317A12	Obsolete—contact Eaton	—	8BT4-100E	—	—	—
434D317A13	Obsolete—contact Eaton	—	8BT4-125E	—	—	—
434D317A14	Obsolete—contact Eaton	—	8BT4-150E	—	—	—
434D317A15	Obsolete—contact Eaton	—	8BT4-200E	—	—	—
434D317A23	Obsolete—contact Eaton	—	15BT4-20E	—	—	—
434D317A24	Obsolete—contact Eaton	—	15BT4-25E	—	—	—
434D317A25	Obsolete—contact Eaton	—	15BT4-30E	—	—	—
434D317A26	Obsolete—contact Eaton	—	15BT4-40E	—	—	—
434D317A27	Obsolete—contact Eaton	—	15BT4-50E	—	—	—
434D317A28	Obsolete—contact Eaton	—	15BT4-65E	—	—	—
434D317A29	Obsolete—contact Eaton	—	15BT4-100E	—	—	—
434D317A30	Obsolete—contact Eaton	—	15BT4-125E	—	—	—
434D317A31	Obsolete—contact Eaton	—	15BT4-150E	—	—	—
434D317A32	Obsolete—contact Eaton	—	15BT4-200E	—	—	—
434D317A41	Obsolete—contact Eaton	—	25BT4-20E	—	—	—
434D317A42	Obsolete—contact Eaton	—	25BT4-25E	—	—	—
434D317A43	Obsolete—contact Eaton	—	25BT4-30E	—	—	—
434D317A44	Obsolete—contact Eaton	—	25BT4-40E	—	—	—
434D317A45	Obsolete—contact Eaton	—	25BT4-50E	—	—	—
434D317A46	Obsolete—contact Eaton	—	25BT4-65E	—	—	—
434D317A47	Obsolete—contact Eaton	—	25BT4-250E	—	—	—
434D317A48	Obsolete—contact Eaton	—	25BT4-100E	—	—	—
434D317A49	Obsolete—contact Eaton	—	25BT4-125E	—	—	—
434D317A50	Obsolete—contact Eaton	—	25BT4-150E	—	—	—
434D317A51	Obsolete—contact Eaton	—	25BT4-200E	—	—	—
434D317A59	Obsolete—contact Eaton	—	38BT4-20E	—	—	—
434D317A60	Obsolete—contact Eaton	—	38BT4-25E	—	—	—
434D317A61	Obsolete—contact Eaton	—	38BT4-30E	—	—	—
434D317A62	Obsolete—contact Eaton	—	38BT4-40E	—	—	—
434D317A63	Obsolete—contact Eaton	—	38BT4-50E	—	—	—
434D317A64	Obsolete—contact Eaton	—	38BT4-65E	—	—	—
434D317A65	Obsolete—contact Eaton	—	38BT4-380E	—	—	—
434D317A66	Obsolete—contact Eaton	—	38BT4-100E	—	—	—
434D317A67	Obsolete—contact Eaton	—	38BT4-125E	—	—	—
434D317A68	Obsolete—contact Eaton	—	38BT4-150E	—	—	—
434D317A69	Obsolete—contact Eaton	—	38BT4-200E	—	—	—
434D641G01	Obsolete—contact Eaton	—	DBA3 69 kV—300E fuse	—	—	—

Appendix 2—Superseded Style Number Index

Old 10 Digit Style Number	Current Eaton Catalog Number	Eaton 10 Digit Style Number	Description	Type	Voltage Rating kV Max.	Current Rating Amperes
434D650G01	Obsolete—contact Eaton	—	BA-800 mounting—4.8 kV	—	—	—
434D650G02	Obsolete—contact Eaton	—	BA-800 mounting—4.8 kV	—	—	—
434D650G03	Obsolete—contact Eaton	—	BA-800 mounting—4.8 kV	—	—	—
434D650G04	Obsolete—contact Eaton	—	BA-800 mounting—4.8 kV	—	—	—
434D650G05	Obsolete—contact Eaton	—	BA-800 mounting—7.2 kV	—	—	—
434D650G06	Obsolete—contact Eaton	—	BA-800 mounting—7.2 kV	—	—	—
434D650G07	Obsolete—contact Eaton	—	BA-800 mounting—7.2 kV	—	—	—
434D650G08	Obsolete—contact Eaton	—	BA-800 mounting—7.2 kV	—	—	—
434D650G09	Obsolete—contact Eaton	—	BA-800 mounting—13.2 kV	—	—	—
434D650G10	Obsolete—contact Eaton	—	BA-800 mounting—13.2 kV	—	—	—
434D650G11	Obsolete—contact Eaton	—	BA-800 mounting—13.2 kV	—	—	—
434D650G12	Obsolete—contact Eaton	—	BA-800 mounting—13.2 kV	—	—	—
434D650G13	Obsolete—contact Eaton	—	BA-800 mounting—14.4 kV	—	—	—
434D650G14	Obsolete—contact Eaton	—	BA-800 mounting—14.4 kV	—	—	—
434D650G15	Obsolete—contact Eaton	—	BA-800 mounting—14.4 kV	—	—	—
434D650G16	Obsolete—contact Eaton	—	BA-800 mounting—14.4 kV	—	—	—
434D830A01	Obsolete—contact Eaton	—	DBA-1—7.2 kV vertical mounting	—	—	—
434D830A02	Obsolete—contact Eaton	—	DBA-1—14.4 kV vertical mounting	—	—	—
434D830A03	Obsolete—contact Eaton	—	DBA-1—23 kV vertical mounting	—	—	—
434D830A04	Obsolete—contact Eaton	—	DBA-1—34.5 kV vertical mounting	—	—	—
434D830A05	Obsolete—contact Eaton	—	DBA-1—46 kV vertical mounting	—	—	—
434D830A09	Obsolete—contact Eaton	—	DBA-1—69 kV vertical mounting	—	—	—
434D831A01	Obsolete—contact Eaton	—	DBA-2/5—34.5 kV vertical mounting	—	—	—
434D831A02	Obsolete—contact Eaton	—	DBA-2/5—46 kV vertical mounting	—	—	—
434D831A09	Obsolete—contact Eaton	—	DBA-2/5—69 kV vertical mounting	—	—	—
434D831A10	Obsolete—contact Eaton	—	DBA-2—92 kV mounting	—	—	—
434D831A11	Obsolete—contact Eaton	—	DBA-2—115 kV mounting	—	—	—
434D831A12	Obsolete—contact Eaton	—	DBA-2—138 kV mounting	—	—	—
435B590G02	CLS-BAND	435B590G02	—	CLS	—	—
436B732G01	PF8-5	436B732G01	—	EMOLD	—	—
436B732G03	PF8-8	436B732G03	—	EMOLD	—	—
436B732G05	PF8-12	436B732G05	—	EMOLD	—	—
436B732G07	PF8-18	436B732G07	—	EMOLD	—	—
436B764G01	Obsolete—contact Eaton	—	DBA-1—7.2 kV inverted mounting	—	—	—
436B764G02	Obsolete—contact Eaton	—	DBA-1—14.4 kV inverted mounting	—	—	—
436B764G03	Obsolete—contact Eaton	—	DBA-1—23 kV inverted mounting	—	—	—
436B764G04	Obsolete—contact Eaton	—	DBA-1—34.5 kV inverted mounting	—	—	—
436B764G05	Obsolete—contact Eaton	—	DBA-1—46 kV inverted mounting	—	—	—
436B764G10	Obsolete—contact Eaton	—	DBA-1—69 kV inverted mounting	—	—	—
436B764G20	Obsolete—contact Eaton	—	DBA-2/5—34.5 kV inverted mounting	—	—	—
436B764G21	Obsolete—contact Eaton	—	DBA-2/5—46 kV inverted mounting	—	—	—
436B764G22	Obsolete—contact Eaton	—	DBA-2/5—69 kV inverted mounting	—	—	—
438D724A01	RDB2-VL	438D724A01	—	RDB2	—	200
438D724G01	Obsolete—contact Eaton	—	4.8/7.2 kV 95BIL RDB-2 mounting cap and pin	—	—	—
438D724G02	Obsolete—contact Eaton	—	15 kV 110BIL RDB-2 mounting cap and pin	—	—	—
438D724G03	Obsolete—contact Eaton	—	23 kV 150BIL RDB-2 mounting cap and pin	—	—	—
438D724G04	Obsolete—contact Eaton	—	34.5 kV 200BIL RDB-2 mounting cap and pin	—	—	—
438D724G05	Obsolete—contact Eaton	—	4.8/7.2 kV 110BIL RDB-2 mounting cap and pin	—	—	—
438D724G06	Obsolete—contact Eaton	—	15 kV 150BIL RDB-2 mounting cap and pin	—	—	—
438D724G07	Obsolete—contact Eaton	—	23 kV 200BIL RDB-2 mounting cap and pin	—	—	—
438D724G08	Obsolete—contact Eaton	—	34.5 kV 250BIL RDB-2 mounting cap and pin	—	—	—
438D724G09	8RDB2-VM	438D724G09	—	RDB2	8.3	200
438D724G10	15RDB2-VM	438D724G10	—	RDB2	15.5	200

Appendix 2—Superseded Style Number Index

Old 10 Digit Style Number	Current Eaton Catalog Number	Eaton 10 Digit Style Number	Description	Type	Voltage Rating kV Max.	Current Rating Amperes
438D724G11	25RDB2-VM	438D724G11	—	RDB2	25.5	200
438D724G12	38RDB2-VM	438D724G12	—	RDB2	38	200
438D724G13	8RDB2-HVM	438D724G13	—	RDB2	8.3	200
438D724G14	15RDB2-HVM	438D724G14	—	RDB2	15.5	200
438D724G15	25RDB2-HVM	438D724G15	—	RDB2	25.5	200
438D724G16	38RDB2-HVM	438D724G16	—	RDB2	38	200
438D725A01	RDB4-VL	438D725A01	—	RDB4	—	400
438D725G01	Obsolete—contact Eaton	—	4.8/7.2 kV 95BIL RDB-4 mounting cap and pin	—	—	—
438D725G02	Obsolete—contact Eaton	—	15 kV 110BIL RDB-4 mounting cap and pin	—	—	—
438D725G03	Obsolete—contact Eaton	—	23 kV 150BIL RDB-4 mounting cap and pin	—	—	—
438D725G04	Obsolete—contact Eaton	—	34.5 kV 200BIL RDB-4 mounting cap and pin	—	—	—
438D725G05	Obsolete—contact Eaton	—	4.8/7.2 kV 110BIL RDB-4 mounting cap and pin	—	—	—
438D725G06	Obsolete—contact Eaton	—	15 kV 150BIL RDB-4 mounting cap and pin	—	—	—
438D725G07	Obsolete—contact Eaton	—	23 kV 200BIL RDB-4 mounting cap and pin	—	—	—
438D725G08	Obsolete—contact Eaton	—	34.5 kV 250BIL RDB-4 mounting cap and pin	—	—	—
438D725G09	8RDB4-VM	438D725G09	—	RDB4	8.3	400
438D725G10	15RDB4-VM	438D725G10	—	RDB4	15.5	400
438D725G11	25RDB4-VM	438D725G11	—	RDB4	25.5	300
438D725G12	38RDB4-VM	438D725G12	—	RDB4	38	300
438D725G13	8RDB4-HVM	438D725G13	—	RDB4	8.3	400
438D725G14	15RDB4-HVM	438D725G14	—	RDB4	15.5	400
438D725G15	25RDB4-HVM	438D725G15	—	RDB4	25.5	300
438D725G16	38RDB4-HVM	438D725G16	—	RDB4	38	300
438D726A02	Obsolete—contact Eaton	—	2.4/7.2 kV RBA-2 rear connected live parts	—	—	—
438D726A03	Obsolete—contact Eaton	—	2.4/7.2 kV RBA-2 rear connected live parts	—	—	—
438D726A04	Obsolete—contact Eaton	—	2.4/7.2 kV RBA-2 rear connected live parts	—	—	—
438D726A06	Obsolete—contact Eaton	—	13.8 kV RBA-2 rear connected live parts	—	—	—
438D726A07	Obsolete—contact Eaton	—	13.8 kV RBA-2 rear connected live parts	—	—	—
438D726A08	Obsolete—contact Eaton	—	13.8 kV RBA-2 rear connected live parts	—	—	—
438D726A10	Obsolete—contact Eaton	—	14.4 kV RBA-2 rear connected live parts	—	—	—
438D726A11	Obsolete—contact Eaton	—	14.4 kV RBA-2 rear connected live parts	—	—	—
438D726A12	Obsolete—contact Eaton	—	14.4 kV RBA-2 rear connected live parts	—	—	—
438D726G02	Obsolete—contact Eaton	—	2.4/4.8 kV RBA-2 rear connected mountings	—	—	—
438D726G03	Obsolete—contact Eaton	—	2.4/4.8 kV RBA-2 rear connected mountings	—	—	—
438D726G04	Obsolete—contact Eaton	—	2.4/4.8 kV RBA-2 rear connected mountings	—	—	—
438D726G06	Obsolete—contact Eaton	—	7.2 kV RBA-2 rear connected mountings	—	—	—
438D726G07	Obsolete—contact Eaton	—	7.2 kV RBA-2 rear connected mountings	—	—	—
438D726G08	Obsolete—contact Eaton	—	7.2 kV RBA-2 rear connected mountings	—	—	—
438D726G10	Obsolete—contact Eaton	—	13.8 kV RBA-2 rear connected mountings	—	—	—
438D726G11	Obsolete—contact Eaton	—	13.8 kV RBA-2 rear connected mountings	—	—	—
438D726G12	Obsolete—contact Eaton	—	13.8 kV RBA-2 rear connected mountings	—	—	—
438D726G14	Obsolete—contact Eaton	—	14.4 kV RBA-2 rear connected mountings	—	—	—
438D726G15	Obsolete—contact Eaton	—	14.4 kV RBA-2 rear connected mountings	—	—	—
438D726G16	Obsolete—contact Eaton	—	14.4 kV RBA-2 rear connected mountings	—	—	—
438D727A02	Obsolete—contact Eaton	—	2.4/7.2 kV RBA-4 rear connected live parts	—	—	—
438D727A03	Obsolete—contact Eaton	—	2.4/7.2 kV RBA-4 rear connected live parts	—	—	—
438D727A04	Obsolete—contact Eaton	—	2.4/7.2 kV RBA-4 rear connected live parts	—	—	—
438D727A06	Obsolete—contact Eaton	—	13.8 kV RBA-4 rear connected live parts	—	—	—
438D727A07	Obsolete—contact Eaton	—	13.8 kV RBA-4 rear connected live parts	—	—	—
438D727A08	Obsolete—contact Eaton	—	13.8 kV RBA-4 rear connected live parts	—	—	—
438D727A10	Obsolete—contact Eaton	—	14.4 kV RBA-4 rear connected live parts	—	—	—
438D727A11	Obsolete—contact Eaton	—	14.4 kV RBA-4 rear connected live parts	—	—	—
438D727A12	Obsolete—contact Eaton	—	14.4 kV RBA-4 rear connected live parts	—	—	—

Appendix 2—Superseded Style Number Index

Old 10 Digit Style Number	Current Eaton Catalog Number	Eaton 10 Digit Style Number	Description	Type	Voltage Rating kV Max.	Current Rating Amperes
438D727G02	Obsolete—contact Eaton	—	2.4/4.8 kV RBA-4 rear connected mountings	—	—	—
438D727G03	Obsolete—contact Eaton	—	2.4/4.8 kV RBA-4 rear connected mountings	—	—	—
438D727G04	Obsolete—contact Eaton	—	2.4/4.8 kV RBA-4 rear connected mountings	—	—	—
438D727G06	Obsolete—contact Eaton	—	7.2 kV RBA-4 rear connected mountings	—	—	—
438D727G07	Obsolete—contact Eaton	—	7.2 kV RBA-4 rear connected mountings	—	—	—
438D727G08	Obsolete—contact Eaton	—	7.2 kV RBA-4 rear connected mountings	—	—	—
438D727G10	Obsolete—contact Eaton	—	13.8 kV RBA-4 rear connected mountings	—	—	—
438D727G11	Obsolete—contact Eaton	—	13.8 kV RBA-4 rear connected mountings	—	—	—
438D727G12	Obsolete—contact Eaton	—	13.8 kV RBA-4 rear connected mountings	—	—	—
438D727G14	Obsolete—contact Eaton	—	14.4 kV RBA-4 rear connected mountings	—	—	—
438D727G15	Obsolete—contact Eaton	—	14.4 kV RBA-4 rear connected mountings	—	—	—
438D727G16	Obsolete—contact Eaton	—	14.4 kV RBA-4 rear connected mountings	—	—	—
438D727G18	Obsolete—contact Eaton	—	23 kV RBA-4 rear connected mountings	—	—	—
438D727G19	Obsolete—contact Eaton	—	24 kV RBA-4 rear connected mountings	—	—	—
438D727G20	Obsolete—contact Eaton	—	25 kV RBA-4 rear connected mountings	—	—	—
439D347A02	Obsolete—contact Eaton	—	4.8/14.4 kV rear connected live parts	—	—	—
439D347A03	Obsolete—contact Eaton	—	4.8/14.4 kV rear connected live parts	—	—	—
439D347A04	Obsolete—contact Eaton	—	4.8/14.4 kV rear connected live parts	—	—	—
439D347G02	Obsolete—contact Eaton	—	2.4/4.8 kV RBA-2 rear connected mountings	—	—	—
439D347G03	Obsolete—contact Eaton	—	2.4/4.8 kV RBA-2 rear connected mountings	—	—	—
439D347G04	Obsolete—contact Eaton	—	2.4/4.8 kV RBA-2 rear connected mountings	—	—	—
439D347G06	Obsolete—contact Eaton	—	7.2 kV RBA-2 rear connected mountings	—	—	—
439D347G07	Obsolete—contact Eaton	—	7.2 kV RBA-2 rear connected mountings	—	—	—
439D347G08	Obsolete—contact Eaton	—	7.2 kV RBA-2 rear connected mountings	—	—	—
439D347G10	Obsolete—contact Eaton	—	13.8 kV RBA-2 rear connected mountings	—	—	—
439D347G11	Obsolete—contact Eaton	—	13.8 kV RBA-2 rear connected mountings	—	—	—
439D347G12	Obsolete—contact Eaton	—	13.8 kV RBA-2 rear connected mountings	—	—	—
439D347G14	Obsolete—contact Eaton	—	14.4 kV RBA-2 rear connected mountings	—	—	—
439D347G15	Obsolete—contact Eaton	—	14.4 kV RBA-2 rear connected mountings	—	—	—
439D347G16	Obsolete—contact Eaton	—	14.4 kV RBA-2 rear connected mountings	—	—	—
439D349A02	Obsolete—contact Eaton	—	4.8/14.4 kV RBA-4 rear connected live parts	—	—	—
439D349A03	Obsolete—contact Eaton	—	4.8/14.4 kV RBA-4 rear connected live parts	—	—	—
439D349A04	Obsolete—contact Eaton	—	4.8/14.4 kV RBA-4 rear connected live parts	—	—	—
439D349G02	Obsolete—contact Eaton	—	2.4/4.8 kV RBA-4 rear connected mountings	—	—	—
439D349G03	Obsolete—contact Eaton	—	2.4/4.8 kV RBA-4 rear connected mountings	—	—	—
439D349G04	Obsolete—contact Eaton	—	2.4/4.8 kV RBA-4 rear connected mountings	—	—	—
439D349G06	Obsolete—contact Eaton	—	7.2 kV RBA-4 rear connected mountings	—	—	—
439D349G07	Obsolete—contact Eaton	—	7.2 kV RBA-4 rear connected mountings	—	—	—
439D349G08	Obsolete—contact Eaton	—	7.2 kV RBA-4 rear connected mountings	—	—	—
439D349G10	Obsolete—contact Eaton	—	13.8 kV RBA-4 rear connected mountings	—	—	—
439D349G11	Obsolete—contact Eaton	—	13.8 kV RBA-4 rear connected mountings	—	—	—
439D349G12	Obsolete—contact Eaton	—	13.8 kV RBA-4 rear connected mountings	—	—	—
439D349G14	Obsolete—contact Eaton	—	14.4 kV RBA-4 rear connected mountings	—	—	—
439D349G15	Obsolete—contact Eaton	—	14.4 kV RBA-4 rear connected mountings	—	—	—
439D349G16	Obsolete—contact Eaton	—	14.4 kV RBA-4 rear connected mountings	—	—	—
439D350A13	Obsolete—contact Eaton	—	2.4 kV rear connected CLS mounting	—	—	—
439D350A15	Obsolete—contact Eaton	—	4.8 kV rear connected CLS mounting	—	—	—
439D350A16	Obsolete—contact Eaton	—	4.8 kV rear connected CLS mounting	—	—	—
439D350A23	Obsolete—contact Eaton	—	2.4 kV rear connected CLS mounting	—	—	—
439D350A25	Obsolete—contact Eaton	—	4.8 kV rear connected CLS mounting	—	—	—
439D350A26	Obsolete—contact Eaton	—	4.8 kV rear connected CLS mounting	—	—	—
439D350A33	Obsolete—contact Eaton	—	2.4 kV rear connected CLS mounting	—	—	—
439D350A35	Obsolete—contact Eaton	—	4.8 kV rear connected CLS mounting	—	—	—

Appendix 2—Superseded Style Number Index

Old 10 Digit Style Number	Current Eaton Catalog Number	Eaton 10 Digit Style Number	Description	Type	Voltage Rating kV Max.	Current Rating Amperes
439D350A36	Obsolete—contact Eaton	—	4.8 kV rear connected CLS mounting	—	—	—
439D378G03	15CLE-30E	5981C33G05	—	CLE	15.5	30E
439D378G04	15CLE-40E	5981C19G04	—	CLE	15.5	40E
439D378G05	15CLE-50E	5981C19G05	—	CLE	15.5	50E
439D378G06	15CLE-65E	5981C19G06	—	CLE	15.5	65E
439D482G04	15CLE-80E	5981C19G07	—	CLE	15.5	80E
439D482G05	15CLE-100E	5981C19G08	—	CLE	15.5	100E
439D482G06	15CLE-125E	5981C19G09	—	CLE	15.5	125E
449D339G03	Obsolete—contact Eaton	—	600V 600A SCL fuse	—	—	—
449D361G01	5ACLS-2R	449D597G02	—	CLS	5.08	2R(70)
449D361G02	5ACLS-3R	449D597G03	—	CLS	5.08	3R(100)
449D361G03	5ACLS-4R	449D597G04	—	CLS	5.08	4R(130)
449D361G04	5ACLS-5R	449D597G05	—	CLS	5.08	5R(150)
449D361G05	5ACLS-6R	449D597G06	—	CLS	5.08	6R(170)
449D361G06	5ACLS-9R	151D933H01	—	CLS	5.08	9R(200)
449D361G07	5ACLS-12R	151D933H02	—	CLS	5.08	12R(230)
449D361G08	5ACLS-30	449D597G01	—	CLS	5.08	30
449D362G01	5AHLE-30E	5981C46G05	—	HLE	5.5	30E
449D362G02	5AHLE-50E	5981C46G07	—	HLE	5.5	50E
449D362G03	5AHLE-65E	5981C46G08	—	HLE	5.5	65E
449D362G04	5AHLE-80E	5981C46G09	—	HLE	5.5	80E
449D362G05	5AHLE-100E	5981C46G10	—	HLE	5.5	100E
449D362G06	5AHLE-125E	5981C46G11	—	HLE	5.5	125E
449D362G07	5AHLE-150E	5981C46G12	—	HLE	5.5	150E
449D362G08	5AHLE-200E	5981C46G14	—	HLE	5.5	200E
449D362G09	Obsolete—contact Eaton	—	5ACLE-225E	—	—	—
449D362G10	5AHLE-25E	5981C46G04	—	HLE	5.5	25E
449D472A02	Obsolete—contact Eaton	—	4.8/14 kV RBA-800 rear connected live parts	—	—	—
449D472A03	Obsolete—contact Eaton	—	4.8/14 kV RBA-800 rear connected live parts	—	—	—
449D472A04	Obsolete—contact Eaton	—	4.8/14 kV RBA-800 rear connected live parts	—	—	—
449D472G02	Obsolete—contact Eaton	—	2.4/4.8 kV RBA-800 rear connected mountings	—	—	—
449D472G03	Obsolete—contact Eaton	—	2.4/4.8 kV RBA-800 rear connected mountings	—	—	—
449D472G04	Obsolete—contact Eaton	—	2.4/4.8 kV RBA-800 rear connected mountings	—	—	—
449D472G06	Obsolete—contact Eaton	—	7.2 kV RBA-800 rear connected mountings	—	—	—
449D472G07	Obsolete—contact Eaton	—	7.2 kV RBA-800 rear connected mountings	—	—	—
449D472G08	Obsolete—contact Eaton	—	7.2 kV RBA-800 rear connected mountings	—	—	—
449D472G10	Obsolete—contact Eaton	—	13.8 kV RBA-800 rear connected mountings	—	—	—
449D472G11	Obsolete—contact Eaton	—	13.8 kV RBA-800 rear connected mountings	—	—	—
449D472G12	Obsolete—contact Eaton	—	13.8 kV RBA-800 rear connected mountings	—	—	—
449D472G14	Obsolete—contact Eaton	—	14.4 kV RBA-800 rear connected mountings	—	—	—
449D472G15	Obsolete—contact Eaton	—	14.4 kV RBA-800 rear connected mountings	—	—	—
449D472G16	Obsolete—contact Eaton	—	14.4 kV RBA-800 rear connected mountings	—	—	—
449D513A01	Obsolete—contact Eaton	—	2.4/15 kV RBA-800 rear connected live parts	—	—	—
449D513A02	Obsolete—contact Eaton	—	2.4/15 kV RBA-800 rear connected live parts	—	—	—
449D513A03	Obsolete—contact Eaton	—	2.4/15 kV RBA-800 rear connected live parts	—	—	—
449D513A04	Obsolete—contact Eaton	—	2.4/15 kV RBA-800 rear connected live parts	—	—	—
449D513A05	Obsolete—contact Eaton	—	2.4/15 kV RBA-800 rear connected live parts	—	—	—
449D513G01	Obsolete—contact Eaton	—	2.4/4.8 kV RBA-800 rear connected mountings	—	—	—
449D513G02	Obsolete—contact Eaton	—	2.4/4.8 kV RBA-800 rear connected mountings	—	—	—
449D513G03	Obsolete—contact Eaton	—	2.4/4.8 kV RBA-800 rear connected mountings	—	—	—
449D513G04	Obsolete—contact Eaton	—	2.4/4.8 kV RBA-800 rear connected mountings	—	—	—
449D513G05	Obsolete—contact Eaton	—	7.2 kV RBA-800 rear connected mountings	—	—	—
449D513G06	Obsolete—contact Eaton	—	7.2 kV RBA-800 rear connected mountings	—	—	—

Appendix 2—Superseded Style Number Index

Old 10 Digit Style Number	Current Eaton Catalog Number	Eaton 10 Digit Style Number	Description	Type	Voltage Rating kV Max.	Current Rating Amperes
449D513G07	Obsolete—contact Eaton	—	7.2 kV RBA-800 rear connected mountings	—	—	—
449D513G08	Obsolete—contact Eaton	—	7.2 kV RBA-800 rear connected mountings	—	—	—
449D513G09	Obsolete—contact Eaton	—	13.8 kV RBA-800 rear connected mountings	—	—	—
449D513G10	Obsolete—contact Eaton	—	13.8 kV RBA-800 rear connected mountings	—	—	—
449D513G11	Obsolete—contact Eaton	—	13.8 kV RBA-800 rear connected mountings	—	—	—
449D513G12	Obsolete—contact Eaton	—	13.8 kV RBA-800 rear connected mountings	—	—	—
449D513G13	Obsolete—contact Eaton	—	14.4 kV RBA-800 rear connected mountings	—	—	—
449D513G14	Obsolete—contact Eaton	—	14.4 kV RBA-800 rear connected mountings	—	—	—
449D513G15	Obsolete—contact Eaton	—	14.4 kV RBA-800 rear connected mountings	—	—	—
449D513G16	Obsolete—contact Eaton	—	14.4 kV RBA-800 rear connected mountings	—	—	—
449D514A01	Obsolete—contact Eaton	—	2.4/7.2 kV RBA-800 rear connected live parts	—	—	—
449D514A02	Obsolete—contact Eaton	—	2.4/7.2 kV RBA-800 rear connected live parts	—	—	—
449D514A03	Obsolete—contact Eaton	—	2.4/7.2 kV RBA-800 rear connected live parts	—	—	—
449D514A04	Obsolete—contact Eaton	—	2.4/7.2 kV RBA-800 rear connected live parts	—	—	—
449D514A05	Obsolete—contact Eaton	—	13.8 kV RBA-800 rear connected live parts	—	—	—
449D514A06	Obsolete—contact Eaton	—	13.8 kV RBA-800 rear connected live parts	—	—	—
449D514A07	Obsolete—contact Eaton	—	13.8 kV RBA-800 rear connected live parts	—	—	—
449D514A08	Obsolete—contact Eaton	—	13.8 kV RBA-800 rear connected live parts	—	—	—
449D514A09	Obsolete—contact Eaton	—	14.4 kV RBA-800 rear connected live parts	—	—	—
449D514A10	Obsolete—contact Eaton	—	14.4 kV RBA-800 rear connected live parts	—	—	—
449D514A11	Obsolete—contact Eaton	—	14.4 kV RBA-800 rear connected live parts	—	—	—
449D514A12	Obsolete—contact Eaton	—	14.4 kV RBA-800 rear connected live parts	—	—	—
449D514G01	Obsolete—contact Eaton	—	2.4/4.8 kV RBA-800 rear connected mountings	—	—	—
449D514G02	Obsolete—contact Eaton	—	2.4/4.8 kV RBA-800 rear connected mountings	—	—	—
449D514G03	Obsolete—contact Eaton	—	2.4/4.8 kV RBA-800 rear connected mountings	—	—	—
449D514G04	Obsolete—contact Eaton	—	2.4/4.8 kV RBA-800 rear connected mountings	—	—	—
449D514G05	Obsolete—contact Eaton	—	7.2 kV RBA-800 rear connected mountings	—	—	—
449D514G06	Obsolete—contact Eaton	—	7.2 kV RBA-800 rear connected mountings	—	—	—
449D514G07	Obsolete—contact Eaton	—	7.2 kV RBA-800 rear connected mountings	—	—	—
449D514G08	Obsolete—contact Eaton	—	7.2 kV RBA-800 rear connected mountings	—	—	—
449D514G09	Obsolete—contact Eaton	—	13.8 kV RBA-800 rear connected mountings	—	—	—
449D514G10	Obsolete—contact Eaton	—	13.8 kV RBA-800 rear connected mountings	—	—	—
449D514G11	Obsolete—contact Eaton	—	13.8 kV RBA-800 rear connected mountings	—	—	—
449D514G12	Obsolete—contact Eaton	—	13.8 kV RBA-800 rear connected mountings	—	—	—
449D514G13	Obsolete—contact Eaton	—	14.4 kV RBA-800 rear connected mountings	—	—	—
449D514G14	Obsolete—contact Eaton	—	14.4 kV RBA-800 rear connected mountings	—	—	—
449D514G15	Obsolete—contact Eaton	—	14.4 kV RBA-800 rear connected mountings	—	—	—
449D514G16	Obsolete—contact Eaton	—	14.4 kV RBA-800 rear connected mountings	—	—	—
449D515A01	RDB8-DL	449D515A01	—	RDB8	—	720
449D515G01	Obsolete—contact Eaton	—	4.8/7.2 kV RDB-800 mounting, cap and pin 95BIL	—	—	—
449D515G02	Obsolete—contact Eaton	—	15 kV RBA-800 mounting, cap and pin 110BIL	—	—	—
449D515G03	Obsolete—contact Eaton	—	23 kV RDB-800 mounting, cap and pin 150BIL	—	—	—
449D515G04	Obsolete—contact Eaton	—	34.5 kV RDB-800 mounting, cap and pin 200BIL	—	—	—
449D515G05	Obsolete—contact Eaton	—	4.8/7.2 kV RDB-800 mounting, cap and pin 110BIL	—	—	—
449D515G06	Obsolete—contact Eaton	—	15 kV RBA-800 mounting, cap and pin 150BIL	—	—	—
449D515G07	Obsolete—contact Eaton	—	23 kV RDB-800 mounting, cap and pin 200BIL	—	—	—
449D515G08	Obsolete—contact Eaton	—	34.5 kV RDB-800 mounting, cap and pin 250BIL	—	—	—
449D515G09	8RBB8-VM	449D515G09	—	RDB8	8.3	720
449D515G10	15RBB8-VM	449D515G10	—	RDB8	15.5	7230
449D515G11	25RBB8-VM	449D515G11	—	RDB8	25.5	540
449D515G12	38RBB8-VM	449D515G12	—	RDB8	38	540
449D515G13	8RBB8H-VM	449D515G13	—	RDB8	8.3	720
449D515G14	15RBB8-HVM	449D515G14	—	RDB8	15.5	7230

Appendix 2—Superseded Style Number Index

Old 10 Digit Style Number	Current Eaton Catalog Number	Eaton 10 Digit Style Number	Description	Type	Voltage Rating kV Max.	Current Rating Amperes
449D515G15	25RBB8-HVM	449D515G15	—	RDB8	25.5	540
449D515G16	38RBB8-HVM	449D515G16	—	RDB8	38	540
449D595G01	5CLE-750E	449D595G01	—	CLE	5.5	750E
449D595G02	5CLE-600E	449D595G02	—	CLE	5.5	600E
449D595G03	Obsolete—contact Eaton	—	1/2 5CLE-1350E	—	—	—
449D595G04	Obsolete—contact Eaton	—	1/2 5CLE-1100E	—	—	—
449D597G01	5ACLS-30	449D597G01	—	CLS	5.08	30
449D597G02	5ACLS-2R	449D597G02	—	CLS	5.08	2R(70)
449D597G03	5ACLS-3R	449D597G03	—	CLS	5.08	3R(100)
449D597G04	5ACLS-4R	449D597G04	—	CLS	5.08	4R(130)
449D597G05	5ACLS-5R	449D597G05	—	CLS	5.08	5R(150)
449D597G06	5ACLS-6R	449D597G06	—	CLS	5.08	6R(170)
449D598G01	Obsolete—contact Eaton	—	8CLB-80C	—	—	—
449D598G02	Obsolete—contact Eaton	—	8CLB-100C	—	—	—
449D598G03	Obsolete—contact Eaton	—	8CLB-125C	—	—	—
449D635G01	8CLE-30E	5981C31G05	—	CLE	8.3	30E
449D635G02	8CLE-40E	5981C17G04	—	CLE	8.3	40E
449D635G03	8CLE-50E	5981C17G05	—	CLE	8.3	50E
449D635G04	8CLE-65E	5981C17G06	—	CLE	8.3	65E
449D635G05	8CLE-80E	5981C17G07	—	CLE	8.3	80E
449D635G06	8CLE-100E	5981C17G08	—	CLE	8.3	100E
449D635G07	8CLE-125E	5981C17G09	—	CLE	8.3	125E
449D636G01	8CLE-150E	5981C17G10	—	CLE	8.3	150E
449D636G02	8CLE-125E	5981C17G09	—	CLE	8.3	125E
449D636G04	8CLE-100E	5981C17G08	—	CLE	8.3	100E
449D671A07	8RBT2-20E	449D671A07	—	RBA2	8.3	20E
449D671A08	8RBT2-25E	449D671A08	—	RBA2	8.3	25E
449D671A09	8RBT2-30E	449D671A09	—	RBA2	8.3	30E
449D671A10	8RBT2-40E	449D671A10	—	RBA2	8.3	40E
449D671A11	8RBT2-50E	449D671A11	—	RBA2	8.3	50E
449D671A12	8RBT2-65E	449D671A12	—	RBA2	8.3	65E
449D671A13	8RBT2-80E	449D671A13	—	RBA2	8.3	80E
449D671A14	8RBT2-100E	449D671A14	—	RBA2	8.3	100E
449D671A15	8RBT2-125E	449D671A15	—	RBA2	8.3	125E
449D671A16	8RBT2-150E	449D671A16	—	RBA2	8.3	150E
449D671A18	8RBT2-200E	449D671A18	—	RBA2	8.3	200E
449D671A27	15RBT2-20E	449D671A27	—	RBA2	15.5	20E
449D671A28	15RBT2-25E	449D671A28	—	RBA2	15.5	25E
449D671A29	15RBT2-30E	449D671A29	—	RBA2	15.5	30E
449D671A30	15RBT2-40E	449D671A30	—	RBA2	15.5	40E
449D671A31	15RBT2-50E	449D671A31	—	RBA2	15.5	50E
449D671A32	15RBT2-65E	449D671A32	—	RBA2	15.5	65E
449D671A33	15RBT2-80E	449D671A33	—	RBA2	15.5	80E
449D671A34	15RBT2-100E	449D671A34	—	RBA2	15.5	100E
449D671A35	15RBT2-125E	449D671A35	—	RBA2	15.5	125E
449D671A36	15RBT2-150E	449D671A36	—	RBA2	15.5	150E
449D671A38	15RBT2-200E	449D671A38	—	RBA2	15.5	200E
449D671A47	25RBT2-20E	449D671A47	—	RBA2	25.5	20E
449D671A48	25RBT2-25E	449D671A48	—	RBA2	25.5	25E
449D671A49	25RBT2-30E	449D671A49	—	RBA2	25.5	30E
449D671A50	25RBT2-40E	449D671A50	—	RBA2	25.5	40E
449D671A51	25RBT2-50E	449D671A51	—	RBA2	25.5	50E
449D671A52	25RBT2-65E	449D671A52	—	RBA2	25.5	65E

Appendix 2—Superseded Style Number Index

Old 10 Digit Style Number	Current Eaton Catalog Number	Eaton 10 Digit Style Number	Description	Type	Voltage Rating kV Max.	Current Rating Amperes
449D671A53	25RBT2-80E	449D671A53	—	RBA2	25.5	80E
449D671A54	25RBT2-100E	449D671A54	—	RBA2	25.5	100E
449D671A55	25RBT2-125E	449D671A55	—	RBA2	25.5	125E
449D671A56	25RBT2-150E	449D671A56	—	RBA2	25.5	150E
449D671A58	25RBT2-200E	449D671A58	—	RBA2	25.5	200E
449D671A67	38RBT2-20E	449D671A67	—	RBA2	38	20E
449D671A68	38RBT2-25E	449D671A68	—	RBA2	38	25E
449D671A69	38RBT2-30E	449D671A69	—	RBA2	38	30E
449D671A70	38RBT2-40E	449D671A70	—	RBA2	38	40E
449D671A71	38RBT2-50E	449D671A71	—	RBA2	38	50E
449D671A72	38RBT2-65E	449D671A72	—	RBA2	38	65E
449D671A73	38RBT2-80E	449D671A73	—	RBA2	38	80E
449D671A74	38RBT2-100E	449D671A74	—	RBA2	38	100E
449D671A75	38RBT2-125E	449D671A75	—	RBA2	38	125E
449D671A76	38RBT2-150E	449D671A76	—	RBA2	38	150E
449D671A78	38RBT2-200E	449D671A78	—	RBA2	38	200E
449D672A07	8RBT4-20E	5982C49A07	—	RBA4	8.3	20E
449D672A08	8RBT4-25E	5982C49A08	—	RBA4	8.3	25E
449D672A09	8RBT4-30E	5982C49A09	—	RBA4	8.3	30E
449D672A10	8RBT4-40E	5982C49A10	—	RBA4	8.3	40E
449D672A11	8RBT4-50E	5982C49A11	—	RBA4	8.3	50E
449D672A12	8RBT4-65E	5982C49A12	—	RBA4	8.3	65E
449D672A13	8RBT4-80E	5982C49A13	—	RBA4	8.3	80E
449D672A14	8RBT4-100E	5982C49A14	—	RBA4	8.3	100E
449D672A15	8RBT4-125E	5982C49A15	—	RBA4	8.3	125E
449D672A16	8RBT4-150E	5982C49A16	—	RBA4	8.3	150E
449D672A18	8RBT4-200E	5982C49A18	—	RBA4	8.3	200E
449D672A19	8RBT4-250E	5982C49A19	—	RBA4	8.3	250E
449D672A20	8RBT4-300E	5982C49A20	—	RBA4	8.3	300E
449D672A21	8RBT4-400E	5982C49A21	—	RBA4	8.3	400E
449D672A32	15RBT4-20E	5982C49A32	—	RBA4	15.5	20E
449D672A33	15RBT4-25E	5982C49A33	—	RBA4	15.5	25E
449D672A34	15RBT4-30E	5982C49A34	—	RBA4	15.5	30E
449D672A35	15RBT4-40E	5982C49A35	—	RBA4	15.5	40E
449D672A36	15RBT4-50E	5982C49A36	—	RBA4	15.5	50E
449D672A37	15RBT4-65E	5982C49A37	—	RBA4	15.5	65E
449D672A38	15RBT4-80E	5982C49A38	—	RBA4	15.5	80E
449D672A39	15RBT4-100E	5982C49A39	—	RBA4	15.5	100E
449D672A40	15RBT4-125E	5982C49A40	—	RBA4	15.5	125E
449D672A41	15RBT4-150E	5982C49A41	—	RBA4	15.5	150E
449D672A43	15RBT4-200E	5982C49A43	—	RBA4	15.5	200E
449D672A44	15RBT4-250E	5982C49A44	—	RBA4	15.5	250E
449D672A45	15RBT4-300E	5982C49A45	—	RBA4	15.5	300E
449D672A46	15RBT4-400E	5982C49A46	—	RBA4	15.5	400E
449D672A57	25RBT4-20E	5982C49A57	—	RBA4	25.5	20E
449D672A58	25RBT4-25E	5982C49A58	—	RBA4	25.5	25E
449D672A59	25RBT4-30E	5982C49A59	—	RBA4	25.5	30E
449D672A60	25RBT4-40E	5982C49A60	—	RBA4	25.5	40E
449D672A61	25RBT4-50E	5982C49A61	—	RBA4	25.5	50E
449D672A62	25RBT4-65E	5982C49A62	—	RBA4	25.5	65E
449D672A63	25RBT4-80E	5982C49A63	—	RBA4	25.5	80E
449D672A64	25RBT4-100E	5982C49A64	—	RBA4	25.5	100E
449D672A65	25RBT4-125E	5982C49A65	—	RBA4	25.5	125E

Appendix 2—Superseded Style Number Index

Old 10 Digit Style Number	Current Eaton Catalog Number	Eaton 10 Digit Style Number	Description	Type	Voltage Rating kV Max.	Current Rating Amperes
449D672A66	25RBT4-150E	5982C49A66	—	RBA4	25.5	150E
449D672A68	25RBT4-200E	5982C49A68	—	RBA4	25.5	200E
449D672A69	25RBT4-250E	5982C49A69	—	RBA4	25.5	250E
449D672A70	25RBT4-300E	5982C49A70	—	RBA4	25.5	300E
449D672A82	38RBT4-20E	5982C49A82	—	RBA4	38	20E
449D672A83	38RBT4-25E	5982C49A83	—	RBA4	38	25E
449D672A84	38RBT4-30E	5982C49A84	—	RBA4	38	30E
449D672A85	38RBT4-40E	5982C49A85	—	RBA4	38	40E
449D672A86	38RBT4-50E	5982C49A86	—	RBA4	38	50E
449D672A87	38RBT4-65E	5982C49A87	—	RBA4	38	65E
449D672A88	38RBT4-80E	5982C49A88	—	RBA4	38	80E
449D672A89	38RBT4-100E	5982C49A89	—	RBA4	38	100E
449D672A90	38RBT4-125E	5982C49A90	—	RBA4	38	125E
449D672A91	38RBT4-150E	5982C49A91	—	RBA4	38	150E
449D672A93	38RBT4-200E	5982C49A93	—	RBA4	38	200E
449D672A94	38RBT4-250E	5982C49A94	—	RBA4	38	250E
449D672A95	38RBT4-300E	5982C49A95	—	RBA4	38	300E
449D689G03	Obsolete—contact Eaton	—	1000V SCL 600A fuse	—	—	—
449D689G04	Obsolete—contact Eaton	—	1000V SCL 600A fuse	—	—	—
449D689G05	Obsolete—contact Eaton	—	1000V SCL 800A fuse	—	—	—
449D759G01	5CLS-2R	151D241G02	—	CLS	5.08	2R(70)
449D759G02	5CLS-3R	151D241G03	—	CLS	5.08	3R(100)
449D759G03	5CLS-4R	151D241G04	—	CLS	5.08	4R(130)
449D759G04	5CLS-5R	151D241G05	—	CLS	5.08	5R(150)
449D759G05	5CLS-6R	151D241G06	—	CLS	5.08	6R(170)
449D759G06	5CLS-9R	151D961G01	—	CLS	5.08	9R(200)
449D759G07	5CLS-12R	151D961G02	—	CLS	5.08	12R(230)
449D759G08	5CLS-30	151D241G02	—	CLS	5.08	30
449D760G01	5CLS-18R	151D961G03	—	CLS	5.08	18R(390)
449D760G02	5CLS-24R	151D961G04	—	CLS	5.08	24R(450)
449D795G01	Obsolete—contact Eaton	—	4.8/7.2 kV RDB2 45 mounting, cap and pin	—	—	—
449D795G02	Obsolete—contact Eaton	—	14.4 kV RDB2 45 mounting, cap and pin	—	—	—
449D795G03	Obsolete—contact Eaton	—	23 kV RDB2 45 mounting, cap and pin	—	—	—
449D795G04	Obsolete—contact Eaton	—	34.5 kV RDB2 45 mounting, cap and pin	—	—	—
449D795G06	Obsolete—contact Eaton	—	4.8/7.2 kV RDB2 45 mounting, station post	—	—	—
449D795G07	Obsolete—contact Eaton	—	14.4 kV RDB2 45 mounting, station post	—	—	—
449D795G08	Obsolete—contact Eaton	—	23 kV RDB2 45 mounting, station post	—	—	—
449D795G09	Obsolete—contact Eaton	—	34.5 kV RDB2 45 mounting, station post	—	—	—
449D795G11	Obsolete—contact Eaton	—	4.8/7.2 kV RDB4 45 mounting, cap and pin	—	—	—
449D795G12	Obsolete—contact Eaton	—	14.4 kV RDB4 45 mounting, cap and pin	—	—	—
449D795G13	Obsolete—contact Eaton	—	23 kV RDB4 45 mounting, cap and pin	—	—	—
449D795G14	Obsolete—contact Eaton	—	34.5 kV RDB4 45 mounting, cap and pin	—	—	—
449D795G16	Obsolete—contact Eaton	—	4.8/7.2 kV RDB4 45 mounting, station post	—	—	—
449D795G17	Obsolete—contact Eaton	—	14.4 kV RDB4 45 mounting, station post	—	—	—
449D795G18	Obsolete—contact Eaton	—	23 kV RDB4 45 mounting, station post	—	—	—
449D795G19	Obsolete—contact Eaton	—	34.5 kV RDB4 45 mounting, station post	—	—	—
449D796G01	Obsolete—contact Eaton	—	4.8/7.2 kV RDB2 90 mounting, cap and pin	—	—	—
449D796G02	Obsolete—contact Eaton	—	14.4 kV RDB2 90 mounting, cap and pin	—	—	—
449D796G03	Obsolete—contact Eaton	—	23 kV RDB2 90 mounting, cap and pin	—	—	—
449D796G04	Obsolete—contact Eaton	—	34.5 kV RDB2 90 mounting, cap and pin	—	—	—
449D796G06	Obsolete—contact Eaton	—	4.8/7.2 kV RDB2 90 mounting, station post	—	—	—
449D796G07	Obsolete—contact Eaton	—	14.4 kV RDB2 90 mounting, station post	—	—	—
449D796G08	Obsolete—contact Eaton	—	23 kV RDB2 90 mounting, station post	—	—	—

Appendix 2—Superseded Style Number Index

Old 10 Digit Style Number	Current Eaton Catalog Number	Eaton 10 Digit Style Number	Description	Type	Voltage Rating kV Max.	Current Rating Amperes
449D796G09	Obsolete—contact Eaton	—	34.5 kV RDB2 90 mounting, station post	—	—	—
449D796G11	Obsolete—contact Eaton	—	4.8/7.2 kV RDB4 90 mounting, cap and pin	—	—	—
449D796G12	Obsolete—contact Eaton	—	14.4 kV RDB4 90 mounting, cap and pin	—	—	—
449D796G13	Obsolete—contact Eaton	—	23 kV RDB4 90 mounting, cap and pin	—	—	—
449D796G14	Obsolete—contact Eaton	—	34.5 kV RDB4 90 mounting, cap and pin	—	—	—
449D796G16	Obsolete—contact Eaton	—	4.8/7.2 kV RDB4 90 mounting, station post	—	—	—
449D796G17	Obsolete—contact Eaton	—	14.4 kV RDB4 90 mounting, station post	—	—	—
449D796G18	Obsolete—contact Eaton	—	23 kV RDB4 90 mounting, station post	—	—	—
449D796G19	Obsolete—contact Eaton	—	34.5 kV RDB4 90 mounting, station post	—	—	—
449D797G01	2CLE-25E	449D797G01	—	CLE	2.75	25E
449D797G02	2CLE-30E	449D797G02	—	CLE	2.75	30E
449D797G03	2CLE-50E	449D797G03	—	CLE	2.75	50E
449D797G04	2CLE-65E	449D797G04	—	CLE	2.75	65E
449D797G05	2CLE-80E	449D797G05	—	CLE	2.75	80E
449D797G06	2CLE-100E	449D797G06	—	CLE	2.75	100E
449D797G07	2CLE-125E	449D797G07	—	CLE	2.75	125E
449D797G08	2CLE-150E	449D797G08	—	CLE	2.75	150E
449D797G09	2CLE-200E	449D797G09	—	CLE	2.75	200E
449D797G10	Obsolete—contact Eaton	—	2CLE-225E	—	—	—
449D797G11	2CLE-10E	449D797G11	—	CLE	2.75	10E
449D797G12	2CLE-40E	449D797G12	—	CLE	2.75	40E
449D797G13	2CLE-250E	449D797G13	—	CLE	2.75	250E
449D797G14	2CLE-300E	449D797G14	—	CLE	2.75	300E
449D797G15	2CLE-350X	449D797G15	—	CLE	2.75	350X
449D797G17	2CLE-400X	449D797G17	—	CLE	2.75	400X
449D797G18	2CLE-450X	449D797G18	—	CLE	2.75	450X
449D926G01	5HCLS-2R	151D240G02	—	CLS	5.08	2R(70)
449D926G02	5HCLS-3R	151D240G03	—	CLS	5.08	3R(100)
449D926G03	5HCLS-4R	151D240G04	—	CLS	5.08	4R(130)
449D926G04	5HCLS-5R	151D240G05	—	CLS	5.08	5R(150)
449D926G05	5HCLS-6R	151D240G06	—	CLS	5.08	6R(170)
449D926G06	5HCLS-9R	151D962G01	—	CLS	5.08	9R(200)
449D926G07	5HCLS-12R	151D962G02	—	CLS	5.08	12R(230)
449D926G08	5HCLS-30	151D240G01	—	CLS	5.08	30
449D935G01	5HCLS-18R	151D962G03	—	CLS	5.08	18R(390)
449D935G02	5HCLS-24R	151D962G04	—	CLS	5.08	24R(450)
502B206G01	Obsolete—contact Eaton	—	Adaptor kit	—	—	—
502B206G02	Obsolete—contact Eaton	—	Adaptor kit	—	—	—
502B206G03	Obsolete—contact Eaton	—	Adaptor kit	—	—	—
505D420G01	8DBA1-3E	505D420G01	—	DBA1	8.3	3
505D420G02	15DBA1-3E	505D420G02	—	DBA1	15.5	3
505D420G03	25DBA1-3E	505D420G03	—	DBA1	25.5	3
505D420G04	38DBA1-3E	505D420G04	—	DBA1	38	3
505D420G05	48DBA1-3E	505D420G05	—	DBA1	48	3
505D420G06	72DBA1-3E	505D420G06	—	DBA1	72	3
505D420G07	38DBA2-3E	505D420G07	—	DBA2	38	3
505D420G08	48DBA2-3E	505D420G08	—	DBA2	48	3
505D420G09	72DBA2-3E	505D420G09	—	DBA2	72	3
505D615A01	Obsolete—contact Eaton	—	BA-400 live parts	—	—	—
505D615A02	Obsolete—contact Eaton	—	BA-400 live parts	—	—	—
505D615A03	Obsolete—contact Eaton	—	BA-400 live parts	—	—	—
505D615A04	Obsolete—contact Eaton	—	BA-400 live parts	—	—	—
505D615A05	Obsolete—contact Eaton	—	BA-400 live parts	—	—	—

Appendix 2—Superseded Style Number Index

Old 10 Digit Style Number	Current Eaton Catalog Number	Eaton 10 Digit Style Number	Description	Type	Voltage Rating kV Max.	Current Rating Amperes
505D615A06	Obsolete—contact Eaton	—	BA-400 live parts	—	—	—
505D615A07	Obsolete—contact Eaton	—	BA-400 live parts	—	—	—
505D615A08	Obsolete—contact Eaton	—	BA-400 live parts	—	—	—
505D615A09	Obsolete—contact Eaton	—	BA-400 live parts	—	—	—
505D615A10	Obsolete—contact Eaton	—	BA-400 live parts	—	—	—
505D616A01	Obsolete—contact Eaton	—	BA-200 live parts	—	—	—
505D620A01	Obsolete—contact Eaton	—	BA-200 live parts	—	—	—
505D620A02	Obsolete—contact Eaton	—	BA-200 live parts	—	—	—
505D620A03	Obsolete—contact Eaton	—	BA-200 live parts	—	—	—
505D620A04	Obsolete—contact Eaton	—	BA-200 live parts	—	—	—
505D620A05	Obsolete—contact Eaton	—	BA-200 live parts	—	—	—
505D620A06	Obsolete—contact Eaton	—	BA-200 live parts	—	—	—
505D620A07	Obsolete—contact Eaton	—	BA-200 live parts	—	—	—
505D620A08	Obsolete—contact Eaton	—	BA-200 live parts	—	—	—
565D990A02	2CLS-2R	591C812G02	—	CLS	2.54	2R(70)
565D990A04	2CLS-4R	591C812G04	—	CLS	2.54	4R(130)
565D990A06	2CLS-6R	591C812G06	—	CLS	2.54	6R(170)
565D990A09	2CLS-9R	591C812G07	—	CLS	2.54	9R(200)
565D990A12	2CLS-12R	591C812G08	—	CLS	2.54	12R(230)
565D990A15	5CLS-2R	151D241G02	—	CLS	5.08	2R(70)
565D990A17	5CLS-4R	151D241G04	—	CLS	5.08	4R(130)
565D990A19	5CLS-6R	151D241G06	—	CLS	5.08	6R(170)
565D990A22	5CLS-9R	151D962G01	—	CLS	5.08	9R(200)
565D990A25	5CLS-12R	151D962G02	—	CLS	5.08	12R(230)
565C991A04	8BA2-10E	117D123A04	—	BA2	8.3	10E
565C991A05	8BA2-15E	117D123A05	—	BA2	8.3	15E
565C991A06	8BA2-20E	117D123A06	—	BA2	8.3	20E
565C991A07	8BA2-25E	117D123A07	—	BA2	8.3	25E
565C991A08	8BA2-30E	117D123A08	—	BA2	8.3	30E
565C991A09	8BA2-40E	117D123A09	—	BA2	8.3	40E
565C991A11	8BA2-65E	117D123A11	—	BA2	8.3	65E
565C991A12	8BA2-80E	117D123A12	—	BA2	8.3	80E
565C991A13	8BA2-100E	117D123A13	—	BA2	8.3	100E
565C991A15	8BA2-150E	117D123A15	—	BA2	8.3	150E
565C991A16	8BA2-200E	117D123A16	—	BA2	8.3	200E
565C991A21	15BA2-15E	117D123A21	—	BA2	15.5	15E
565C991A23	15BA2-25E	117D123A23	—	BA2	15.5	25E
565C991A24	15BA2-30E	117D123A24	—	BA2	15.5	30E
565C991A26	15BA2-50E	117D123A26	—	BA2	15.5	50E
565C991A27	15BA2-65E	117D123A27	—	BA2	15.5	65E
565C991A28	15BA2-80E	117D123A28	—	BA2	15.5	80E
565C991A31	15BA2-150E	117D123A31	—	BA2	15.5	150E
565C991A32	15BA2-200E	117D123A32	—	BA2	15.5	200E
565D993A11	8BA4-65E	116D977A11	—	BA4	8.3	65E
565D993A12	8BA4-80E	116D977A12	—	BA4	8.3	80E
565D993A13	8BA4-100E	116D977A13	—	BA4	8.3	100E
565D993A14	8BA4-125E	116D977A14	—	BA4	8.3	125E
565D993A16	8BA4-200E	116D977A16	—	BA4	8.3	200E
565D993A17	8BA4-250E	116D977A17	—	BA4	8.3	250E
565D993A18	8BA4-300E	116D977A18	—	BA4	8.3	300E
565D993A19	8BA4-400E	116D977A19	—	BA4	8.3	400E
565D993A21	15BA4-5E	116D977A22	—	BA4	15.5	5E
565D993A25	15BA4-20E	116D977A26	—	BA4	15.5	20E

Appendix 2—Superseded Style Number Index

Old 10 Digit Style Number	Current Eaton Catalog Number	Eaton 10 Digit Style Number	Description	Type	Voltage Rating kV Max.	Current Rating Amperes
565D993A27	15BA4-30E	116D977A28	—	BA4	15.5	30E
565D993A28	15BA4-40E	116D977A29	—	BA4	15.5	40E
565D993A30	15BA4-65E	116D977A31	—	BA4	15.5	65E
565D993A31	15BA4-80E	116D977A32	—	BA4	15.5	80E
565D993A32	15BA4-100E	116D977A33	—	BA4	15.5	100E
565D993A33	15BA4-125E	116D977A34	—	BA4	15.5	125E
565D993A34	15BA4-150E	116D977A35	—	BA4	15.5	150E
565D993A36	15BA4-250E	116D977A37	—	BA4	15.5	250E
565D993A37	15BA4-300E	116D977A38	—	BA4	15.5	300E
565D993A48	15BA4-400E	116D977A39	—	BA4	15.5	400E
566C137A25	15CLE-80E	5981C19G07	—	CLE	15.5	80E
566C137A26	15CLE-100E	5981C19G08	—	CLE	15.5	100E
5809A21G01	CLPT-DLC	—	—	—	—	—
591C142G01	2ACLS-25	591C142G01	—	CLS	2.54	25
591C142G02	2ACLS-2R	591C142G02	—	CLS	2.54	2R(70)
591C142G03	2ACLS-3R	591C142G03	—	CLS	2.54	3R(100)
591C142G04	2ACLS-4R	591C142G04	—	CLS	2.54	4R(130)
591C142G05	2ACLS-5R	591C142G05	—	CLS	2.54	5R(150)
591C142G06	2ACLS-6R	591C142G06	—	CLS	2.54	6R(170)
591C142G07	2ACLS-9R	591C142G07	—	CLS	2.54	9R(200)
591C142G08	2ACLS-12R	591C142G08	—	CLS	2.54	12R(230)
591C143G01	2ACLS-18R	591C143G01	—	CLS	2.54	18R(390)
591C143G02	2ACLS-24R	591C143G02	—	CLS	2.54	24R(450)
591C144G02	Obsolete—contact Eaton	—	2.4/7.2 kV RBA-200 rear con. live parts	—	—	—
591C144G03	Obsolete—contact Eaton	—	2.4/7.2 kV RBA-200 rear con. live parts	—	—	—
591C144G04	Obsolete—contact Eaton	—	2.4/7.2 kV RBA-200 rear con. live parts	—	—	—
591C144G06	Obsolete—contact Eaton	—	13.8 kV RBA-200 rear con. live parts	—	—	—
591C144G07	Obsolete—contact Eaton	—	13.8 kV RBA-200 rear con. live parts	—	—	—
591C144G08	Obsolete—contact Eaton	—	13.8 kV RBA-200 rear con. live parts	—	—	—
591C144G10	Obsolete—contact Eaton	—	14.4 kV RBA-200 rear con. live parts	—	—	—
591C144G11	Obsolete—contact Eaton	—	14.4 kV RBA-200 rear con. live parts	—	—	—
591C144G12	Obsolete—contact Eaton	—	14.4 kV RBA-200 rear con. live parts	—	—	—
591C144G17	Obsolete—contact Eaton	—	2.4/7.2 kV RBA-200 rear con. live parts	—	—	—
591C144G18	Obsolete—contact Eaton	—	2.4/7.2 kV RBA-200 rear con. live parts	—	—	—
591C144G19	Obsolete—contact Eaton	—	2.4/7.2 kV RBA-200 rear con. live parts	—	—	—
591C144G21	Obsolete—contact Eaton	—	13.8 kV RBA-200 rear con. live parts	—	—	—
591C144G22	Obsolete—contact Eaton	—	13.8 kV RBA-200 rear con. live parts	—	—	—
591C144G23	Obsolete—contact Eaton	—	13.8 kV RBA-200 rear con. live parts	—	—	—
591C144G25	Obsolete—contact Eaton	—	14.4/23 kV RBA-200 rear con. live parts	—	—	—
591C144G26	Obsolete—contact Eaton	—	14.4/23 kV RBA-200 rear con. live parts	—	—	—
591C144G27	Obsolete—contact Eaton	—	14.4/23 kV RBA-200 rear con. live parts	—	—	—
591C152G01	Obsolete—contact Eaton	—	8CLB-30C	—	—	—
591C152G02	Obsolete—contact Eaton	—	8CLB-45C	—	—	—
591C152G03	Obsolete—contact Eaton	—	8CLB-60C	—	—	—
591C154G01	Obsolete—contact Eaton	—	2.4 kV CLS-13 25 fuse	—	—	—
591C154G02	Obsolete—contact Eaton	—	2.4 kV CLS-13 2R fuse	—	—	—
591C154G03	Obsolete—contact Eaton	—	2.4 kV CLS-13 3R fuse	—	—	—
591C154G04	Obsolete—contact Eaton	—	2.4 kV CLS-13 4R fuse	—	—	—
591C154G05	Obsolete—contact Eaton	—	2.4 kV CLS-13 5R fuse	—	—	—
591C154G06	Obsolete—contact Eaton	—	2.4 kV CLS-13 6R fuse	—	—	—
591C154G07	Obsolete—contact Eaton	—	2.4 kV CLS-13 9R fuse	—	—	—
591C154G08	Obsolete—contact Eaton	—	2.4 kV CLS-13 12R fuse	—	—	—
591C155G01	2HCLS-25	591C155G01	—	CLS	2.54	25

Appendix 2—Superseded Style Number Index

Old 10 Digit Style Number	Current Eaton Catalog Number	Eaton 10 Digit Style Number	Description	Type	Voltage Rating kV Max.	Current Rating Amperes
591C155G02	2HCLS-2R	591C155G02	—	CLS	2.54	2R(70)
591C155G03	2HCLS-3R	591C155G03	—	CLS	2.54	3R(100)
591C155G04	2HCLS-4R	591C155G04	—	CLS	2.54	4R(130)
591C155G05	2HCLS-5R	591C155G05	—	CLS	2.54	5R(150)
591C155G06	2HCLS-6R	591C155G06	—	CLS	2.54	6R(170)
591C155G07	2HCLS-9R	591C155G07	—	CLS	2.54	9R(200)
591C155G08	2HCLS-12R	591C155G08	—	CLS	2.54	12R(230)
591C156G01	Obsolete—contact Eaton	—	2.4 kV CLS-13 18R fuse	—	—	—
591C156G02	Obsolete—contact Eaton	—	2.4 kV CLS-13 24R fuse	—	—	—
591C157G01	2HCLS-18R	591C157G01	—	CLS	2.54	18R(390)
591C157G02	2HCLS-24R	591C157G02	—	CLS	2.54	24R(450)
591C162G01	15CLT-30	9570D10G01	—	CLT	15.5	30
591C163G05	Obsolete—contact Eaton	—	8.3 kV 15A FDL fuse	—	—	—
591C163G06	Obsolete—contact Eaton	—	17.1 kV 15A FDL fuse	—	—	—
591C163G07	Obsolete—contact Eaton	—	8.3 kV 25A FDL fuse	—	—	—
591C163G10	Obsolete—contact Eaton	—	8.3 kV 40A FDL fuse	—	—	—
591C172G01	CLS700-DUMMY	591C172G01	—	CLS	5.08	—
591C240G02	Obsolete	—	23CLTB-18	—	—	—
591C248G02	8NCLPT-5E	591C248G02	—	NCLPT	8.3	5E
591C248G07	8NCLPT-1E	591C248G07	—	NCLPT	8.3	1E
591C252G03	8NCLPT-8E	591C252G03	—	NCLPT	8.3	8E
591C254G01	Obsolete—contact Eaton	—	8.3 kV 5A CLTS fuse	—	—	—
591C254G02	Obsolete—contact Eaton	—	8.3 kV 8A CLTS fuse	—	—	—
591C254G03	Obsolete—contact Eaton	—	8.3 kV 12A CLTS fuse	—	—	—
591C254G04	Obsolete—contact Eaton	—	8.3 kV 18A CLTS fuse	—	—	—
591C273G03	8CLT-12	591C273G03	—	CLT	8.3	12
591C358G01	8RBA8-INH	5981C54G01	—	RBA8	8.3	720
591C358G02	15RBA8-INH	5981C54G02	—	RBA8	15.5	720
591C358G03	25RBA8-INH	5981C54G03	—	RBA8	25.5	540
591C358G04	38RBA8-INH	5981C54G04	—	RBA8	38	540
591C376G01	15CLE-175E	5981C25G01	—	CLE	15.5	175E
591C376G02	15CLE-150E	5981C19G10	—	CLE	15.5	150E
591C404G01	Obsolete—contact Eaton	—	8CLTB-18	—	—	—
591C607G01	RBA4-FLTR	591C607G01	(3 pack)	RBA4	—	—
591C607G02	RBA4-FLTR-HC	591C607G02	(3 pack)	RBA4	—	—
591C607G03	RBA4-FLTR	591C607G03	(1 pack)	RBA4	—	—
591C607G04	RBA4-FLTR-HC	591C607G04	(1 pack)	RBA4	—	—
591C812G01	2CLS-25	591C812G01	—	CLS	2.54	25
591C812G02	2CLS-2R	591C812G02	—	CLS	2.54	2R(70)
591C812G03	2CLS-3R	591C812G03	—	CLS	2.54	3R(100)
591C812G04	2CLS-4R	591C812G04	—	CLS	2.54	4R(130)
591C812G05	2CLS-5R	591C812G05	—	CLS	2.54	5R(150)
591C812G06	2CLS-6R	591C812G06	—	CLS	2.54	6R(170)
591C812G07	2CLS-9R	591C812G07	—	CLS	2.54	9R(200)
591C812G08	2CLS-12R	591C812G08	—	CLS	2.54	12R(230)
591C813G01	2CLS-18R	591C813G01	—	CLS	2.54	18R(390)
591C813G02	2CLS-24R	591C813G02	—	CLS	2.54	24R(450)
592C250G01	317A487H04	7186A29G14	—	NCLPT	5.5	3E
595C204G04	CLE-DF-E	9078A63G04	—	CLE	—	450
5978C31G01	PF8-30	5978C31G01	—	EMOLD	—	—
5978C62G01	4CX-18C	5978C62G01	—	CX	4.3	18C
5978C62G02	4XC-25C	5978C62G02	—	CX	4.3	25C
5978C62G03	4CX-35C	5978C62G03	—	CX	4.3	35C

Appendix 2—Superseded Style Number Index

Old 10 Digit Style Number	Current Eaton Catalog Number	Eaton 10 Digit Style Number	Description	Type	Voltage Rating kV Max.	Current Rating Amperes
5978C62G04	8CX-4.5C	5978C62G04	—	CX	8.3	4.5C
5978C62G05	8CX-6C	5978C62G05	—	CX	8.3	6C
5978C62G06	8CX-8C	5978C62G06	—	CX	8.3	8C
5978C62G21	4CXI-18C	5978C62G21	—	CX	4.3	18C
5978C62G22	4XC-25C	5978C62G22	—	CX	4.3	25C
5978C62G23	4CXI-35C	5978C62G23	—	CX	4.3	35C
5978C62G24	8CXI-4.5C	5978C62G24	—	CX	8.3	4.5C
5978C62G25	8CXI-6C	5978C62G25	—	CX	8.3	6C
5978C62G26	8CXI-8C	5978C62G26	—	CX	8.3	8C
5978C66G01	4XC-45C	5978C66G01	—	CX	4.3	45C
5978C66G02	4CX-50C	5978C66G02	—	CX	4.3	50C
5978C66G03	4CX-65C	5978C66G03	—	CX	4.3	65C
5978C66G04	4CX-75C	5978C66G04	—	CX	4.3	75C
5978C66G05	4CX-100C	5978C66G05	—	CX	4.3	100C
5978C66G21	4XC-45C	5978C66G21	—	CX	4.3	45C
5978C66G22	4CXI-50C	5978C66G22	—	CX	4.3	50C
5978C66G23	4CXI-65C	5978C66G23	—	CX	4.3	65C
5978C66G24	4CXI-75C	5978C66G24	—	CX	4.3	75C
5978C66G25	4CXI-100C	5978C66G25	—	CX	4.3	100C
5978C70G01	5CX-18C	5978C70G01	—	CX	5.5	18C
5978C70G02	5CX-20C	5978C70G02	—	CX	5.5	20C
5978C70G03	5CX-25C	5978C70G03	—	CX	5.5	25C
5978C70G04	5CX-30C	5978C70G04	—	CX	5.5	30C
5978C70G05	5CX-40C	5978C70G05	—	CX	5.5	40C
5978C70G06	5CX-50C	5978C70G06	—	CX	5.5	50C
5978C70G07	5CX-65C	5978C70G07	—	CX	5.5	65C
5978C70G08	5CX-75C	5978C70G08	—	CX	5.5	75C
5978C70G21	5CXI-18C	5978C70G21	—	CX	5.5	18C
5978C70G22	5CXI-20C	5978C70G22	—	CX	5.5	20C
5978C70G23	5CXI-25C	5978C70G23	—	CX	5.5	25C
5978C70G24	5CXI-30C	5978C70G24	—	CX	5.5	30C
5978C70G25	5CXI-40C	5978C70G25	—	CX	5.5	40C
5978C70G26	5CXI-50C	5978C70G26	—	CX	5.5	50C
5978C70G27	5CXI-65C	5978C70G27	—	CX	5.5	65C
5978C70G28	5CXI-75C	5978C70G28	—	CX	5.5	75C
5978C72G01	8CX-18C	5978C72G01	—	CX	8.3	18C
5978C72G02	8CX-20C	5978C72G02	—	CX	8.3	20C
5978C72G03	8CX-25C	5978C72G03	—	CX	8.3	25C
5978C72G04	8CX-30C	5978C72G04	—	CX	8.3	30C
5978C72G05	8CX-40C	5978C72G05	—	CX	8.3	40C
5978C72G21	8CXI-18C	5978C72G21	—	CX	8.3	18C
5978C72G22	8CXI-20C	5978C72G22	—	CX	8.3	20C
5978C72G23	8CXI-25C	5978C72G23	—	CX	8.3	25C
5978C72G24	8CXI-30C	5978C72G24	—	CX	8.3	30C
5978C72G25	8CXI-40C	5978C72G25	—	CX	8.3	40C
5978C92G01	17DBU-15SE	5981C77G01	—	DBU	17	15SE
5978C92G02	17DBU-20SE	5981C77G02	—	DBU	17	20SE
5978C92G03	17DBU-25SE	5981C77G03	—	DBU	17	25SE
5978C92G04	17DBU-30SE	5981C77G04	—	DBU	17	30SE
5978C92G05	17DBU-40SE	5981C77G05	—	DBU	17	40SE
5978C92G06	17DBU-50SE	5981C77G06	—	DBU	17	50SE
5978C92G07	17DBU-65SE	5981C77G07	—	DBU	17	65SE
5978C92G08	17DBU-80SE	5981C77G08	—	DBU	17	80SE

Appendix 2—Superseded Style Number Index

Old 10 Digit Style Number	Current Eaton Catalog Number	Eaton 10 Digit Style Number	Description	Type	Voltage Rating kV Max.	Current Rating Amperes
5978C92G09	17DBU-100SE	5981C77G09	—	DBU	17	100SE
5978C92G10	17DBU-125SE	5981C77G10	—	DBU	17	125SE
5978C92G11	17DBU-150SE	5981C77G11	—	DBU	17	150SE
5978C92G12	17DBU-175SE	5981C77G12	—	DBU	17	175SE
5978C92G13	17DBU-200SE	5981C77G13	—	DBU	17	200SE
5978C92G14	Obsolete—contact Eaton	—	17DBU-1	—	—	—
5978C92G15	17DBU-3K	5981C75G01	—	DBU	17	3K
5978C92G16	17DBU-6K	5981C75G02	—	DBU	17	6K
5978C92G17	17DBU-8K	5981C75G03	—	DBU	17	8K
5978C92G18	17DBU-10K	5981C75G04	—	DBU	17	10K
5978C92G19	17DBU-12K	5981C75G05	—	DBU	17	12K
5978C92G20	17DBU-15K	5981C75G06	—	DBU	17	15K
5978C92G21	17DBU-20K	5981C75G07	—	DBU	17	20K
5978C92G22	17DBU-25K	5981C75G08	—	DBU	17	25K
5978C92G23	17DBU-30K	5981C75G09	—	DBU	17	30K
5978C92G24	17DBU-40K	5981C75G10	—	DBU	17	40K
5978C92G25	17DBU-50K	5981C75G11	—	DBU	17	50K
5978C92G26	17DBU-65K	5981C75G12	—	DBU	17	65K
5978C92G27	17DBU-80K	5981C75G13	—	DBU	17	80K
5978C92G28	17DBU-100K	5981C75G14	—	DBU	17	100K
5978C92G29	17DBU-140K	5981C75G15	—	DBU	17	140K
5978C92G30	17DBU-200K	5981C75G16	—	DBU	17	200K
5978C93G01	27DBU-15SE	5981C87G01	—	DBU	27	15SE
5978C93G02	27DBU-20SE	5981C87G02	—	DBU	27	20SE
5978C93G03	27DBU-25SE	5981C87G03	—	DBU	27	25SE
5978C93G04	27DBU-30SE	5981C87G04	—	DBU	27	30SE
5978C93G05	27DBU-40SE	5981C87G05	—	DBU	27	40SE
5978C93G06	27DBU-50SE	5981C87G06	—	DBU	27	50SE
5978C93G07	27DBU-65SE	5981C87G07	—	DBU	27	65SE
5978C93G08	27DBU-80SE	5981C87G08	—	DBU	27	80SE
5978C93G09	27DBU-100SE	5981C87G09	—	DBU	27	100SE
5978C93G10	27DBU-125SE	5981C87G10	—	DBU	27	125SE
5978C93G11	27DBU-150SE	5981C87G11	—	DBU	27	150SE
5978C93G12	27DBU-175SE	5981C87G12	—	DBU	27	175SE
5978C93G13	27DBU-200SE	5981C87G13	—	DBU	27	200SE
5978C93G14	Obsolete—contact Eaton	—	27DBU-1	—	—	—
5978C93G15	27DBU-3K	5981C85G01	—	DBU	27	3K
5978C93G16	27DBU-6K	5981C85G02	—	DBU	27	6K
5978C93G17	27DBU-8K	5981C85G03	—	DBU	27	8K
5978C93G18	27DBU-10K	5981C85G04	—	DBU	27	10K
5978C93G19	27DBU-12K	5981C85G05	—	DBU	27	12K
5978C93G20	27DBU-15K	5981C85G06	—	DBU	27	15K
5978C93G21	27DBU-20K	5981C85G07	—	DBU	27	20K
5978C93G22	27DBU-25K	5981C85G08	—	DBU	27	25K
5978C93G23	27DBU-30K	5981C85G09	—	DBU	27	30K
5978C93G24	27DBU-40K	5981C85G10	—	DBU	27	40K
5978C93G25	27DBU-50K	5981C85G11	—	DBU	27	50K
5978C93G26	27DBU-65K	5981C85G12	—	DBU	27	65K
5978C93G27	27DBU-80K	5981C85G13	—	DBU	27	80K
5978C93G28	27DBU-100K	5981C85G14	—	DBU	27	100K
5978C93G29	27DBU-140K	5981C85G15	—	DBU	27	140K
5978C93G30	27DBU-200K	5981C85G16	—	DBU	27	200K
5978C94G01	38DBU-15SE	5981C97G01	—	DBU	38	15SE

Appendix 2—Superseded Style Number Index

Old 10 Digit Style Number	Current Eaton Catalog Number	Eaton 10 Digit Style Number	Description	Type	Voltage Rating kV Max.	Current Rating Amperes
5978C94G02	38DBU-20SE	5981C97G02	—	DBU	38	20SE
5978C94G03	38DBU-25SE	5981C97G03	—	DBU	38	25SE
5978C94G04	38DBU-30SE	5981C97G04	—	DBU	38	30SE
5978C94G05	38DBU-40SE	5981C97G05	—	DBU	38	40SE
5978C94G06	38DBU-50SE	5981C97G06	—	DBU	38	50SE
5978C94G07	38DBU-65SE	5981C97G07	—	DBU	38	65SE
5978C94G08	38DBU-80SE	5981C97G08	—	DBU	38	80SE
5978C94G09	38DBU-100SE	5981C97G09	—	DBU	38	100SE
5978C94G10	38DBU-125SE	5981C97G10	—	DBU	38	125SE
5978C94G11	38DBU-150SE	5981C97G11	—	DBU	38	150SE
5978C94G12	38DBU-175SE	5981C97G12	—	DBU	38	175SE
5978C94G13	38DBU-200SE	5981C97G13	—	DBU	38	200SE
5978C94G14	Obsolete—contact Eaton	—	38DBU-1	—	—	—
5978C94G15	38DBU-3K	5981C95G01	—	DBU	38	3K
5978C94G16	38DBU-6K	5981C95G02	—	DBU	38	6K
5978C94G17	38DBU-8K	5981C95G03	—	DBU	38	8K
5978C94G18	38DBU-10K	5981C95G04	—	DBU	38	10K
5978C94G19	38DBU-12K	5981C95G05	—	DBU	38	12K
5978C94G20	38DBU-15K	5981C95G06	—	DBU	38	15K
5978C94G21	38DBU-20K	5981C95G07	—	DBU	38	20K
5978C94G22	38DBU-25K	5981C95G08	—	DBU	38	25K
5978C94G23	38DBU-30K	5981C95G09	—	DBU	38	30K
5978C94G24	38DBU-40K	5981C95G10	—	DBU	38	40K
5978C94G25	38DBU-50K	5981C95G11	—	DBU	38	50K
5978C94G26	38DBU-65K	5981C95G12	—	DBU	38	65K
5978C94G27	38DBU-80K	5981C95G13	—	DBU	38	80K
5978C94G28	38DBU-100K	5981C95G14	—	DBU	38	100K
5978C94G29	38DBU-140K	5981C95G15	—	DBU	38	140K
5978C94G30	38DBU-200K	5981C95G16	—	DBU	38	200K
5979C20G03	Obsolete—contact Eaton	—	8.3 kV 40A CLTO fuse	—	—	—
5979C20G04	Obsolete—contact Eaton	—	8.3 kV 50A CLTO fuse	—	—	—
5979C20G05	Obsolete—contact Eaton	—	8.3 kV 65A CLTO fuse	—	—	—
5979C20G06	Obsolete—contact Eaton	—	8.3 kV 80A CLTO fuse	—	—	—
5979C20G07	Obsolete—contact Eaton	—	8.3 kV 100A CLTO fuse	—	—	—
5979C20G08	Obsolete—contact Eaton	—	8.3 kV 125A CLTO fuse	—	—	—
5979C20G12	Obsolete—contact Eaton	—	15.5 kV 40A CLTO fuse	—	—	—
5979C20G13	Obsolete—contact Eaton	—	15.5 kV 50A CLTO fuse	—	—	—
5979C20G14	Obsolete—contact Eaton	—	15.5 kV 65A CLTO fuse	—	—	—
5979C20G15	Obsolete—contact Eaton	—	15.5 kV 80A CLTO fuse	—	—	—
5979C20G16	Obsolete—contact Eaton	—	15.5 kV 100A CLTO fuse	—	—	—
5979C20G17	Obsolete—contact Eaton	—	15.5 kV 125A CLTO fuse	—	—	—
5979C20G21	Obsolete—contact Eaton	—	23 kV 40A CLTO fuse	—	—	—
5979C20G22	Obsolete—contact Eaton	—	23 kV 50A CLTO fuse	—	—	—
5979C77G01	8RBA2-INH	5981C51G01	—	RBA2	8.3	200
5979C77G02	15RBA2-INH	5981C51G02	—	RBA2	15.2	200
5979C77G03	25RBA2-INH	5981C51G03	—	RBA2	25.5	200
5979C77G04	38RBA2-INH	5981C51G04	—	RBA2	38	200
5979C77G05	5979C77G05	5979C77G05	RBA2 holder with RDB shunt	RBA2	8.3	200
5979C77G06	5979C77G06	5979C77G06	RBA2 holder with RDB shunt	RBA2	15.2	200
5979C77G07	5979C77G07	5979C77G07	RBA2 holder with RDB shunt	RBA2	25.5	200
5979C77G08	5979C77G08	5979C77G08	RBA2 holder with RDB shunt	RBA2	38	200
5979C78G01	8RBA4-INH	5981C53G01	—	RBA4	8.3	400
5979C78G02	15RBA4-INH	5981C53G02	—	RBA4	15.2	400

Appendix 2—Superseded Style Number Index

Old 10 Digit Style Number	Current Eaton Catalog Number	Eaton 10 Digit Style Number	Description	Type	Voltage Rating kV Max.	Current Rating Amperes
5979C78G03	25RBA4-INH	5981C53G03	—	RBA4	25.5	300
5979C78G04	38RBA4-INH	5981C53G04	—	RBA4	38	300
5979C78G05	5979C78G05	5979C78G05	RBA4 holder with RDB shunt	RBA4	8.3	400
5979C78G06	5979C78G06	5979C78G06	RBA4 holder with RDB shunt	RBA4	15.2	400
5979C78G07	5979C78G07	5979C78G07	RBA4 holder with RDB shunt	RBA4	25.5	300
5979C78G08	5979C78G08	5979C78G08	RBA4 holder with RDB shunt	RBA4	38	300
5979C79G01	8RBA8-INH	5981C54G01	—	RBA8	8.3	720
5979C79G02	15RBA8-INH	5981C54G02	—	RBA8	15.2	720
5979C79G03	25RBA8-INH	5981C54G03	—	RBA8	25.5	540
5979C79G04	38RBA8-INH	5981C54G04	—	RBA8	38	540
5979C79G05	5979C79G05	5979C79G05	RBA8 holder with RDB shunts	RBA8	8.3	720
5979C79G06	5979C79G06	5979C79G06	RBA8 holder with RDB shunts	RBA8	15.2	720
5979C79G07	5979C79G07	5979C79G07	RBA8 holder with RDB shunts	RBA8	25.5	540
5979C79G08	5979C79G08	5979C79G08	RBA8 holder with RDB shunts	RBA8	38	540
5979C91G01	7CLS70-24R	5979C91G01	—	CLS	7.2	24R(450)
5979C91G02	7CLS70-36R	5979C91G02	—	CLS	7.2	36R(650)
5980C01G01	6DSL-E2500	5980C01G01	—	DSL	0.6	2500
5980C01G02	6DSL-E3000	5980C01G02	—	DSL	0.6	3000
5980C01G03	6DSL-E4000	5980C01G03	—	DSL	0.6	4000
5980C01G04	6DSL-F5000	5980C01G04	—	DSL	0.6	5000
5980C03G05	7CLS70-44R	5980C03G05	—	CLS	7.2	44R(700)
5980C15G01	8DBA1-.5E	5980C15G01	—	DBA1	8.3	0.5
5980C15G03	8DBA1-5E	5980C15G03	—	DBA1	8.3	5E
5980C15G04	8DBA1-7E	5980C15G04	—	DBA1	8.3	7E
5980C15G05	8DBA1-10E	5980C15G05	—	DBA1	8.3	10E
5980C15G06	8DBA1-15E	5980C15G06	—	DBA1	8.3	15E
5980C15G07	8DBA1-20E	5980C15G07	—	DBA1	8.3	20E
5980C15G08	8DBA1-25E	5980C15G08	—	DBA1	8.3	25E
5980C15G09	8DBA1-30E	5980C15G09	—	DBA1	8.3	30E
5980C15G10	8DBA1-40E	5980C15G10	—	DBA1	8.3	40E
5980C15G11	8DBA1-50E	5980C15G11	—	DBA1	8.3	50E
5980C15G12	8DBA1650E	5980C15G12	—	DBA1	8.3	65E
5980C15G13	8DBA1-80E	5980C15G13	—	DBA1	8.3	80E
5980C15G14	8DBA1-100E	5980C15G14	—	DBA1	8.3	100E
5980C15G15	8DBA1-125E	5980C15G15	—	DBA1	8.3	125E
5980C15G16	8DBA1-150E	5980C15G16	—	DBA1	8.3	150E
5980C15G17	8DBA1-200E	5980C15G17	—	DBA1	8.3	200E
5980C15G21	15DBA1-.5E	5980C15G21	—	DBA1	15.5	0.5
5980C15G23	15DBA1-5E	5980C15G23	—	DBA1	15.5	5E
5980C15G24	15DBA1-7E	5980C15G24	—	DBA1	15.5	7E
5980C15G25	15DBA1-10E	5980C15G25	—	DBA1	15.5	10E
5980C15G26	15DBA1-15E	5980C15G26	—	DBA1	15.5	15E
5980C15G27	15DBA1-20E	5980C15G27	—	DBA1	15.5	20E
5980C15G28	15DBA1-25E	5980C15G28	—	DBA1	15.5	25E
5980C15G29	15DBA1-30E	5980C15G29	—	DBA1	15.5	30E
5980C15G30	15DBA1-40E	5980C15G30	—	DBA1	15.5	40E
5980C15G31	15DBA1-50E	5980C15G31	—	DBA1	15.5	50E
5980C15G32	15DBA1650E	5980C15G32	—	DBA1	15.5	65E
5980C15G33	15DBA1-80E	5980C15G33	—	DBA1	15.5	80E
5980C15G34	15DBA1-100E	5980C15G34	—	DBA1	15.5	100E
5980C15G35	15DBA1-125E	5980C15G35	—	DBA1	15.5	125E
5980C15G36	15DBA1-150E	5980C15G36	—	DBA1	15.5	150E
5980C15G37	15DBA1-200E	5980C15G37	—	DBA1	15.5	200E

Appendix 2—Superseded Style Number Index

Old 10 Digit Style Number	Current Eaton Catalog Number	Eaton 10 Digit Style Number	Description	Type	Voltage Rating kV Max.	Current Rating Amperes
5980C16G01	25DBA1-.5E	5980C16G01	—	DBA1	25.5	0.5
5980C16G03	25DBA1-5E	5980C16G03	—	DBA1	25.5	5E
5980C16G04	25DBA1-7E	5980C16G04	—	DBA1	25.5	7E
5980C16G05	25DBA1-10E	5980C16G05	—	DBA1	25.5	10E
5980C16G06	25DBA1-15E	5980C16G06	—	DBA1	25.5	15E
5980C16G07	25DBA1-20E	5980C16G07	—	DBA1	25.5	20E
5980C16G08	25DBA1-25E	5980C16G08	—	DBA1	25.5	25E
5980C16G09	25DBA1-30E	5980C16G09	—	DBA1	25.5	30E
5980C16G10	25DBA1-40E	5980C16G10	—	DBA1	25.5	40E
5980C16G11	25DBA1-50E	5980C16G11	—	DBA1	25.5	50E
5980C16G12	25DBA1650E	5980C16G12	—	DBA1	25.5	65E
5980C16G13	25DBA1-80E	5980C16G13	—	DBA1	25.5	80E
5980C16G14	25DBA1-100E	5980C16G14	—	DBA1	25.5	100E
5980C16G15	25DBA1-125E	5980C16G15	—	DBA1	25.5	125E
5980C16G16	25DBA1-150E	5980C16G16	—	DBA1	25.5	150E
5980C16G17	25DBA1-200E	5980C16G17	—	DBA1	25.5	200E
5980C16G21	38DBA1-.5E	5980C16G21	—	DBA1	38	0.5
5980C16G23	38DBA1-5E	5980C16G23	—	DBA1	38	5E
5980C16G24	38DBA1-7E	5980C16G24	—	DBA1	38	7E
5980C16G25	38DBA1-10E	5980C16G25	—	DBA1	38	10E
5980C16G26	38DBA1-15E	5980C16G26	—	DBA1	38	15E
5980C16G27	38DBA1-20E	5980C16G27	—	DBA1	38	20E
5980C16G28	38DBA1-25E	5980C16G28	—	DBA1	38	25E
5980C16G29	38DBA1-30E	5980C16G29	—	DBA1	38	30E
5980C16G30	38DBA1-40E	5980C16G30	—	DBA1	38	40E
5980C16G31	38DBA1-50E	5980C16G31	—	DBA1	38	50E
5980C16G32	38DBA1650E	5980C16G32	—	DBA1	38	65E
5980C16G33	38DBA1-80E	5980C16G33	—	DBA1	38	80E
5980C16G34	38DBA1-100E	5980C16G34	—	DBA1	38	100E
5980C16G35	38DBA1-125E	5980C16G35	—	DBA1	38	125E
5980C16G36	38DBA1-150E	5980C16G36	—	DBA1	38	150E
5980C16G37	38DBA1-200E	5980C16G37	—	DBA1	38	200E
5980C17G01	48DBA1-.5E	5980C17G01	—	DBA1	48	0.5
5980C17G03	48DBA1-5E	5980C17G03	—	DBA1	48	5E
5980C17G04	48DBA1-7E	5980C17G04	—	DBA1	48	7E
5980C17G05	48DBA1-10E	5980C17G05	—	DBA1	48	10E
5980C17G06	48DBA1-15E	5980C17G06	—	DBA1	48	15E
5980C17G07	48DBA1-20E	5980C17G07	—	DBA1	48	20E
5980C17G08	48DBA1-25E	5980C17G08	—	DBA1	48	25E
5980C17G09	48DBA1-30E	5980C17G09	—	DBA1	48	30E
5980C17G10	48DBA1-40E	5980C17G10	—	DBA1	48	40E
5980C17G11	48DBA1-50E	5980C17G11	—	DBA1	48	50E
5980C17G12	48DBA1650E	5980C17G12	—	DBA1	48	65E
5980C17G13	48DBA1-80E	5980C17G13	—	DBA1	48	80E
5980C17G14	48DBA1-100E	5980C17G14	—	DBA1	48	100E
5980C17G15	48DBA1-125E	5980C17G15	—	DBA1	48	125E
5980C17G16	48DBA1-150E	5980C17G16	—	DBA1	48	150E
5980C17G17	48DBA1-200E	5980C17G17	—	DBA1	48	200E
5980C17G21	72DBA1-.5E	5980C17G21	—	DBA1	72	0.5
5980C17G23	72DBA1-5E	5980C17G23	—	DBA1	72	5E
5980C17G24	72DBA1-7E	5980C17G24	—	DBA1	72	7E
5980C17G25	72DBA1-10E	5980C17G25	—	DBA1	72	10E
5980C17G26	72DBA1-15E	5980C17G26	—	DBA1	72	15E

Appendix 2—Superseded Style Number Index

Old 10 Digit Style Number	Current Eaton Catalog Number	Eaton 10 Digit Style Number	Description	Type	Voltage Rating kV Max.	Current Rating Amperes
5980C17G27	72DBA1-20E	5980C17G27	—	DBA1	72	20E
5980C17G28	72DBA1-25E	5980C17G28	—	DBA1	72	25E
5980C17G29	72DBA1-30E	5980C17G29	—	DBA1	72	30E
5980C17G30	72DBA1-40E	5980C17G30	—	DBA1	72	40E
5980C17G31	72DBA1-50E	5980C17G31	—	DBA1	72	50E
5980C17G32	72DBA1650E	5980C17G32	—	DBA1	72	65E
5980C17G33	72DBA1-80E	5980C17G33	—	DBA1	72	80E
5980C17G34	72DBA1-100E	5980C17G34	—	DBA1	72	100E
5980C17G35	72DBA1-125E	5980C17G35	—	DBA1	72	125E
5980C17G36	72DBA1-150E	5980C17G36	—	DBA1	72	150E
5980C17G37	72DBA1-200E	5980C17G37	—	DBA1	72	200E
5980C19G01	15CX-18C	5980C19G01	—	CX	15.5	18C
5980C19G02	15CX-20C	5980C19G02	—	CX	15.5	20C
5980C19G03	15CX-25C	5980C19G03	—	CX	15.5	25C
5980C19G04	15CX-30C	5980C19G04	—	CX	15.5	30C
5980C19G05	15CX-40C	5980C19G05	—	CX	15.5	40C
5980C19G06	15CX-6C	5980C19G06	—	CX	15.5	6C
5980C19G07	15CX-8C	5980C19G07	—	CX	15.5	8C
5980C19G08	15CX-12C	5980C19G08	—	CX	15.5	12C
5980C19G21	15CXI-18C	5980C19G21	—	CX	15.5	18C
5980C19G22	15CXI-20C	5980C19G22	—	CX	15.5	20C
5980C19G23	15CXI-25C	5980C19G23	—	CX	15.5	25C
5980C19G24	15CXI-30C	5980C19G24	—	CX	15.5	30C
5980C19G25	15CXI-40C	5980C19G25	—	CX	15.5	40C
5980C19G26	15CXI-6C	5980C19G26	—	CX	15.5	6C
5980C19G27	15CXI-8C	5980C19G27	—	CX	15.5	8C
5980C19G28	15CXI-12C	5980C19G28	—	CX	15.5	12C
5980C20G01	5NCLPT-.25E	5980C20G01	—	CLPT	5.5	0.25
5980C20G02	5NCLPT-.5E	5980C20G02	—	CLPT	5.5	0.5
5980C20G03	5NCLPT-2E	5980C20G03	—	CLPT	5.5	2E
5980C20G04	5NCLPT-4E	5980C20G04	—	CLPT	5.5	4E
5980C20G05	8NCLPT-2E	5980C20G05	—	CLPT	8.3	2E
5980C20G06	8NCLPT-4E	5980C20G06	—	CLPT	8.3	4E
5980C21G01	8HLE-20E	5981C30G03	—	HLE	8.3	20E
5980C21G02	8HLE-25E	5981C30G04	—	HLE	8.3	25E
5980C21G03	8HLE-30E	5981C30G05	—	HLE	8.3	30E
5980C21G04	8HLE-40E	5981C16G04	—	HLE	8.3	40E
5980C21G05	8HLE-50E	5981C16G05	—	HLE	8.3	50E
5980C21G06	8HLE-65E	5981C16G06	—	HLE	8.3	65E
5980C21G07	8HLE-80E	5981C16G07	—	HLE	8.3	80E
5980C21G08	8HLE-100E	5981C16G08	—	HLE	8.3	100E
5980C21G09	8HLE-125E	5981C16G09	—	HLE	8.3	125E
5980C21G10	8HLE-150E	5981C16G10	—	HLE	8.3	150E
5980C21G11	8HLE-175E	5981C16G11	—	HLE	8.3	175E
5980C22G01	15HLE-15E	5981C32G02	—	HLE	15.5	15E
5980C22G02	15HLE-20E	5981C32G03	—	HLE	15.5	20E
5980C22G03	15HLE-25E	5981C32G04	—	HLE	15.5	25E
5980C22G04	15HLE-30E	5981C32G05	—	HLE	15.5	30E
5980C22G05	15HLE-40E	5981C18G05	—	HLE	15.5	40E
5980C22G06	15HLE-50E	5981C18G06	—	HLE	15.5	50E
5980C22G07	15HLE-65E	5981C18G07	—	HLE	15.5	65E
5980C22G08	15HLE-80E	5981C18G08	—	HLE	15.5	80E
5980C22G09	15HLE-100E	5981C18G09	—	HLE	15.5	100E

Appendix 2—Superseded Style Number Index

Old 10 Digit Style Number	Current Eaton Catalog Number	Eaton 10 Digit Style Number	Description	Type	Voltage Rating kV Max.	Current Rating Amperes
5980C22G10	15HLE-125E	5981C18G10	—	HLE	15.5	125E
5980C22G11	15HLE-80E	5981C18G08	—	HLE	15.5	80E
5980C22G12	15HLE-100E	5981C18G09	—	HLE	15.5	100E
5980C22G13	15HLE-125E	5981C18G10	—	HLE	15.5	125E
5980C23G01	15CLE-30E	5981C33G03	—	CLE	15.5	30E
5980C23G02	15CLE-40E	5981C19G04	—	CLE	15.5	40E
5980C23G03	15CLE-50E	5981C19G05	—	CLE	15.5	50E
5980C23G04	15CLE-65E	5981C19G06	—	CLE	15.5	65E
5980C23G05	15CLE-80E	5981C19G07	—	CLE	15.5	80E
5980C23G06	15CLE-100E	5981C19G08	—	CLE	15.5	100E
5980C23G07	15CLE-125E	5981C19G09	—	CLE	15.5	125E
5980C23G08	15CLE-150E	5981C19G10	—	CLE	15.5	150E
5980C24G01	8CLE-30E	5981C31G05	—	CLE	8.3	30E
5980C24G02	8CLE-40E	5981C17G04	—	CLE	8.3	40E
5980C24G03	8CLE-50E	5981C17G05	—	CLE	8.3	50E
5980C24G04	8CLE-65E	5981C17G06	—	CLE	8.3	65E
5980C24G05	8CLE-80E	5981C17G07	—	CLE	8.3	80E
5980C24G06	8CLE-100E	5981C17G08	—	CLE	8.3	100E
5980C24G07	8CLE-125E	5981C17G09	—	CLE	8.3	125E
5980C24G08	8CLE-150E	5981C17G10	—	CLE	8.3	150E
5980C24G09	8CLE-175E	5981C17G11	—	CLE	8.3	175E
5980C25G01	5HLE-30E	5981C28G05	—	HLE	5.5	30E
5980C25G02	5HLE-40E	5981C64G01	—	HLE	5.5	40E
5980C25G03	5HLE-50E	5981C64G02	—	HLE	5.5	50E
5980C25G04	5HLE-65E	5981C64G03	—	HLE	5.5	65E
5980C25G05	5HLE-80E	5981C64G04	—	HLE	5.5	80E
5980C25G06	5HLE-100E	5981C64G05	—	HLE	5.5	100E
5980C25G07	5HLE-125E	5981C64G06	—	HLE	5.5	125E
5980C25G08	5HLE-150E	5981C64G07	—	HLE	5.5	150E
5980C25G09	5HLE-175E	5981C64G08	—	HLE	5.5	175E
5980C25G10	5HLE-200E	5981C64G09	—	HLE	5.5	200E
5980C25G11	5HLE-250E	5981C64G10	—	HLE	5.5	250E
5980C26G01	5CLE-30E	5981C28G05	—	CLE	5.5	30E
5980C26G02	5CLE-40E	5981C64G01	—	CLE	5.5	40E
5980C26G03	5CLE-50E	5981C64G02	—	CLE	5.5	50E
5980C26G04	5CLE-65E	5981C64G03	—	CLE	5.5	65E
5980C26G05	5CLE-80E	5981C64G04	—	CLE	5.5	80E
5980C26G06	5CLE-100E	5981C64G05	—	CLE	5.5	100E
5980C26G07	5CLE-125E	5981C64G06	—	CLE	5.5	125E
5980C26G08	5CLE-150E	5981C64G07	—	CLE	5.5	150E
5980C26G09	5CLE-175E	5981C64G08	—	CLE	5.5	175E
5980C26G10	5CLE-200E	5981C64G09	—	CLE	5.5	200E
5980C26G11	5CLE-250E	5981C64G10	—	CLE	5.5	250E
5980C29G01	Obsolete—contact Eaton	—	RBA2-IND	—	—	—
5980C29G02	Obsolete—contact Eaton	—	RBA4-IND	—	—	—
5980C31G01	8HLE-200E	5981C22G01	—	HLE	8.3	200E
5980C31G02	8HLE-250E	5981C22G02	—	HLE	8.3	250E
5980C31G03	8HLE-300E	5981C22G03	—	HLE	8.3	300E
5980C31G04	8HLE-350E	5981C22G04	—	HLE	8.3	350E
5980C32G01	15HLE-150E	5981C24G01	—	HLE	15.5	150E
5980C32G02	15HLE-175E	5981C24G02	—	HLE	15.5	175E
5980C32G03	15HLE-200E	5981C24G03	—	HLE	15.5	200E
5980C32G04	15HLE-250E	5981C24G04	—	HLE	15.5	250E

Appendix 2—Superseded Style Number Index

Old 10 Digit Style Number	Current Eaton Catalog Number	Eaton 10 Digit Style Number	Description	Type	Voltage Rating kV Max.	Current Rating Amperes
5980C32G05	15HLE-150E	5981C24G01	—	HLE	15.5	175E
5980C32G06	15HLE-175E	5981C24G02	—	HLE	15.5	200E
5980C32G07	15HLE-200E	5981C24G03	—	HLE	15.5	250E
5980C32G08	15HLE-250E	5981C24G04	—	HLE	15.5	250E
5980C33G01	15CLE-175E	5981C25G01	—	CLE	15.5	175E
5980C33G02	15CLE-200E	5981C25G02	—	CLE	15.5	200E
5980C33G03	15CLE-250E	5981C25G03	—	CLE	15.5	250E
5980C33G04	15CLE-300E	5981C25G04	—	CLE	15.5	300E
5980C34G01	8CLE-200E	5981C23G01	—	CLE	8.3	200E
5980C34G02	8CLE-250E	5981C23G02	—	CLE	8.3	250E
5980C34G03	8CLE-300E	5981C23G03	—	CLE	8.3	300E
5980C34G04	8CLE-350E	5981C23G04	—	CLE	8.3	350E
5980C35G01	5HLE-300E	5981C66G01	—	HLE	5.5	300E
5980C35G02	5HLE-350E	5981C66G02	—	HLE	5.5	350E
5980C35G03	5HLE-400E	5981C66G03	—	HLE	5.5	400E
5980C35G04	5HLE-450E	5981C66G04	—	HLE	5.5	450E
5980C36G01	5CLE-300E	5981C67G01	—	CLE	5.5	300E
5980C36G02	5CLE-350E	5981C67G02	—	CLE	5.5	350E
5980C36G03	5CLE-400E	5981C67G03	—	CLE	5.5	400E
5980C36G04	5CLE-450E	5981C67G04	—	CLE	5.5	450E
5980C38G01	8RBA2-IDH	5981C50G01	—	RBA2	8.3	200
5980C38G02	15RBA2-IDH	5981C50G02	—	RBA2	15.5	200
5980C38G03	25RBA2-IDH	5981C50G03	—	RBA2	25.5	200
5980C38G04	38RBA2-IDH	5981C50G04	—	RBA2	38	200
5980C39G01	8RBA4-IDH	5981C52G01	—	RBA4	8.3	400
5980C39G02	15RBA4-IDH	5981C52G02	—	RBA4	15.5	400
5980C39G03	25RBA4-IDH	5981C52G03	—	RBA4	25.5	300
5980C39G04	38RBA4-IDH	5981C52G04	—	RBA4	38	300
5980C61G01	5AHLE-30E	5981C46G05	—	HLE	5.5	30E
5980C61G02	5AHLE-40E	5981C46G06	—	HLE	5.5	40E
5980C61G03	5AHLE-50E	5981C46G07	—	HLE	5.5	50E
5980C61G04	5AHLE-65E	5981C46G08	—	HLE	5.5	65E
5980C61G05	5AHLE-80E	5981C46G09	—	HLE	5.5	80E
5980C61G06	5AHLE-100E	5981C46G10	—	HLE	5.5	100E
5980C61G07	5AHLE-125E	5981C46G11	—	HLE	5.5	125E
5980C61G08	5AHLE-150E	5981C46G12	—	HLE	5.5	150E
5980C61G09	5AHLE-175E	5981C46G13	—	HLE	5.5	175E
5980C61G10	5AHLE-200E	5981C46G14	—	HLE	5.5	200E
5980C61G11	5AHLE-250E	5981C46G15	—	HLE	5.5	250E
5980C62G01	8AHLE-20E	5981C47G03	—	HLE	8.3	20E
5980C62G02	8AHLE-25E	5981C47G04	—	HLE	8.3	25E
5980C62G03	8AHLE-30E	5981C47G05	—	HLE	8.3	30E
5980C62G04	8AHLE-40E	5981C47G06	—	HLE	8.3	40E
5980C62G05	8AHLE-50E	5981C47G07	—	HLE	8.3	50E
5980C62G06	8AHLE-65E	5981C47G08	—	HLE	8.3	65E
5980C62G07	8AHLE-80E	5981C47G09	—	HLE	8.3	80E
5980C62G08	8AHLE-100E	5981C47G10	—	HLE	8.3	100E
5980C62G09	8AHLE-125E	5981C47G11	—	HLE	8.3	125E
5980C62G10	8AHLE-150E	5981C47G12	—	HLE	8.3	150E
5980C62G11	8AHLE-175E	5981C47G13	—	HLE	8.3	175E
5980C63G01	Obsolete—contact Eaton	—	15AHLE-15E	—	—	—
5980C63G02	Obsolete—contact Eaton	—	15AHLE-20E	—	—	—
5980C63G03	Obsolete—contact Eaton	—	15AHLE-25E	—	—	—

Appendix 2—Superseded Style Number Index

Old 10 Digit Style Number	Current Eaton Catalog Number	Eaton 10 Digit Style Number	Description	Type	Voltage Rating kV Max.	Current Rating Amperes
5980C63G04	Obsolete—contact Eaton	—	15AHLE-30E	—	—	—
5980C63G05	Obsolete—contact Eaton	—	15AHLE-40E	—	—	—
5980C63G06	Obsolete—contact Eaton	—	15AHLE-50E	—	—	—
5980C63G07	Obsolete—contact Eaton	—	15AHLE-65E	—	—	—
5980C63G08	Obsolete—contact Eaton	—	15AHLE-80E	—	—	—
5980C63G09	Obsolete—contact Eaton	—	15AHLE-100E	—	—	—
5980C63G10	Obsolete—contact Eaton	—	15AHLE-125E	—	—	—
5980C64G01	5AHLE-300E	5981C46G16	—	HLE	5.5	300E
5980C64G02	5AHLE-300E	5981C46G17	—	HLE	5.5	350E
5980C64G03	5AHLE-300E	5981C46G18	—	HLE	5.5	400E
5980C64G04	5AHLE-300E	5981C46G19	—	HLE	5.5	450E
5980C65G01	8AHLE-200E	5981C47G14	—	HLE	8.3	200E
5980C65G02	8AHLE-250E	5981C47G15	—	HLE	8.3	250E
5980C65G03	8AHLE-300E	5981C47G16	—	HLE	8.3	300E
5980C65G04	8AHLE-350E	5981C47G17	—	HLE	8.3	350E
5980C66G01	Obsolete—contact Eaton	—	15AHLE-150E	—	—	—
5980C66G02	Obsolete—contact Eaton	—	15AHLE-175E	—	—	—
5980C66G03	Obsolete—contact Eaton	—	15AHLE-200E	—	—	—
5980C66G04	Obsolete—contact Eaton	—	15AHLE-250E	—	—	—
5980C74G01	8RBA8-INH	5981C54G01	—	RBA8	8.3	720
5980C74G02	15RBA8-INH	5981C54G02	—	RBA9	15.5	720
5980C74G03	25RBA8-INH	5981C54G03	—	RBA10	25.5	540
5980C74G04	38RBA8-INH	5981C54G04	—	RBA11	38	540
5980C81G01	5CLS70-9R	5980C81G01	—	CLS	5.08	9R(200)
5980C81G02	5CLS70-6R	5980C81G02	—	CLS	5.08	6R(170)
5980C81G03	5CLS70-5R	5980C81G03	—	CLS	5.08	5R(150)
5980C81G04	5CLS70-4R	5980C81G04	—	CLS	5.08	4R(130)
5980C81G05	5CLS70-3R	5980C81G05	—	CLS	5.08	3R(100)
5980C81G06	5CLS70-2R	5980C81G06	—	CLS	5.08	2R(70)
5980C81G07	5CLE8-80E	5980C81G07	—	HLE	5.5	80E
5980C81G08	5CLE8-100E	5980C81G08	—	HLE	5.5	100E
5980C81G09	5CLE8-125E	5980C81G09	—	HLE	5.5	125E
5980C81G10	5CLE8-150E	5980C81G10	—	HLE	5.5	150E
5980C81G11	5CLE8-200E	5980C81G11	—	HLE	5.5	200E
5980C81G12	5CLE8-250E	5980C81G12	—	HLE	5.5	250E
5980C81G13	5CLE8-65E	5980C81G13	—	HLE	5.5	65E
5980C81G14	5CLE8-30E	5980C81G14	—	HLE	5.5	30E
5980C81G15	5CLE8-50E	5980C81G15	—	HLE	5.5	50E
5980C81G16	5CLE8-450E	5980C81G16	—	HLE	5.5	40E
5980C82G01	8HLE-20E	5981C30G03	—	HLE	8.3	20E
5980C82G02	8HLE-25E	5981C30G04	—	HLE	8.3	25E
5980C82G03	8HLE-30E	5981C30G05	—	HLE	8.3	30E
5980C82G04	8HLE-40E	5981C16G04	—	HLE	8.3	40E
5980C82G05	8HLE-50E	5981C16G05	—	HLE	8.3	50E
5980C82G06	8HLE-65E	5981C16G06	—	HLE	8.3	65E
5980C82G07	8HLE-80E	5981C16G07	—	HLE	8.3	80E
5980C82G08	8HLE-100E	5981C16G08	—	HLE	8.3	100E
5980C82G09	8HLE-125E	5981C16G09	—	HLE	8.3	125E
5980C82G10	8HLE-150E	5981C16G10	—	HLE	8.3	150E
5980C82G11	8HLE-175E	5981C16G11	—	HLE	8.3	175E
5980C83G01	15HLE-15E	5981C32G02	—	HLE	15.5	15E
5980C83G02	15HLE-20E	5981C32G03	—	HLE	15.5	20E
5980C83G03	15HLE-25E	5981C32G04	—	HLE	15.5	25E

Appendix 2—Superseded Style Number Index

Old 10 Digit Style Number	Current Eaton Catalog Number	Eaton 10 Digit Style Number	Description	Type	Voltage Rating kV Max.	Current Rating Amperes
5980C83G04	15HLE-30E	5981C32G05	—	HLE	15.5	30E
5980C83G05	15HLE-40E	5981C18G05	—	HLE	15.5	40E
5980C83G06	15HLE-50E	5981C18G06	—	HLE	15.5	50E
5980C83G07	15HLE-65E	5981C18G07	—	HLE	15.5	65E
5980C83G08	15HLE-80E	5981C18G08	—	HLE	15.5	80E
5980C83G09	15HLE-100E	5981C18G09	—	HLE	15.5	100E
5980C83G10	15HLE-125E	5981C18G10	—	HLE	15.5	125E
5980C84G01	15CLE-20E	5981C33G03	—	CLE	15.5	20E
5980C84G02	15CLE-25E	5981C33G04	—	CLE	15.5	25E
5980C84G03	15CLE-30E	5981C33G05	—	CLE	15.5	30E
5980C84G04	15CLE-40E	5981C19G04	—	CLE	15.5	40E
5980C84G05	15CLE-50E	5981C19G05	—	CLE	15.5	50E
5980C84G06	15CLE-65E	5981C19G06	—	CLE	15.5	65E
5980C84G07	15CLE-80E	5981C19G07	—	CLE	15.5	80E
5980C84G08	15CLE-100E	5981C19G08	—	CLE	15.5	100E
5980C84G09	15CLE-125E	5981C19G09	—	CLE	15.5	125E
5980C84G10	15CLE-150E	5981C19G10	—	CLE	15.5	150E
5980C85G01	8CLE-20E	5981C31G03	—	CLE	8.3	20E
5980C85G02	8CLE-25E	5981C31G04	—	CLE	8.3	25E
5980C85G03	8CLE-30E	5981C31G05	—	CLE	8.3	30E
5980C85G04	8CLE-40E	5981C17G04	—	CLE	8.3	40E
5980C85G05	8CLE-50E	5981C17G05	—	CLE	8.3	50E
5980C85G06	8CLE-65E	5981C17G06	—	CLE	8.3	65E
5980C85G07	8CLE-80E	5981C17G07	—	CLE	8.3	80E
5980C85G08	8CLE-100E	5981C17G08	—	CLE	8.3	100E
5980C85G09	8CLE-125E	5981C17G09	—	CLE	8.3	125E
5980C85G10	8CLE-150E	5981C17G10	—	CLE	8.3	150E
5980C85G11	8CLE-175E	5981C17G11	—	CLE	8.3	175E
5980C86G01	8HLE-200E	5981C22G01	—	HLE	8.3	200E
5980C86G02	8HLE-250E	5981C22G02	—	HLE	8.3	250E
5980C86G03	8HLE-300E	5981C22G03	—	HLE	8.3	300E
5980C86G04	8HLE-350E	5981C22G04	—	HLE	8.3	350E
5980C87G01	15HLE-150E	5981C24G01	—	HLE	15.5	150E
5980C87G02	15HLE-175E	5981C24G02	—	HLE	15.5	175E
5980C87G03	15HLE-200E	5981C24G03	—	HLE	15.5	200E
5980C87G04	15HLE-250E	5981C24G04	—	HLE	15.5	250E
5980C88G01	15CLE-175E	5981C25G01	—	CLE	15.5	175E
5980C88G02	15CLE-200E	5981C25G02	—	CLE	15.5	200E
5980C88G03	15CLE350E	5981C25G03	—	CLE	15.5	250E
5980C88G04	15CLE-300E	5981C25G04	—	CLE	15.5	300E
5980C89G01	8CLE-200E	5981C23G01	—	CLE	8.3	200E
5980C89G02	8CLE-250E	5981C23G02	—	CLE	8.3	250E
5980C89G03	8CLE-300E	5981C23G03	—	CLE	8.3	300E
5980C89G04	8CLE-350E	5981C23G04	—	CLE	8.3	350E
5980C96G01	5HLE-10E	5981C28G01	—	HLE	5.5	10E
5980C96G02	5HLE-15E	5981C28G02	—	HLE	5.5	15E
5980C96G03	5HLE-20E	5981C28G03	—	HLE	5.5	20E
5980C96G04	5HLE-25E	5981C28G04	—	HLE	5.5	25E
5980C96G05	5HLE-30E	5981C28G05	—	HLE	5.5	30E
5980C97G01	5CLE-10E-D	5981C29G01	—	CLE	5.5	10E
5980C97G02	5CLE-15E-D	5981C29G02	—	CLE	5.5	15E
5980C97G03	5CLE-20E-D	5981C29G03	—	CLE	5.5	20E
5980C97G04	5CLE-25E-D	5981C29G04	—	CLE	5.5	25E

Appendix 2—Superseded Style Number Index

Old 10 Digit Style Number	Current Eaton Catalog Number	Eaton 10 Digit Style Number	Description	Type	Voltage Rating kV Max.	Current Rating Amperes
5980C97G05	5CLE-30E	5981C29G05	—	CLE	5.5	30E
5980C98G01	8HLE-10E	5981C30G01	—	HLE	8.3	10E
5980C98G02	8HLE-15E	5981C30G02	—	HLE	8.3	15E
5980C98G03	8HLE-20E	5981C30G03	—	HLE	8.3	20E
5980C98G04	8HLE-25E	5981C30G04	—	HLE	8.3	25E
5980C98G05	8HLE-30E	5981C30G05	—	HLE	8.3	30E
5980C99G01	8CLE-10E-D	5981C31G01	—	CLE	8.3	10E
5980C99G02	8CLE-15E-D	5981C31G02	—	CLE	8.3	15E
5980C99G03	8CLE-20E-D	5981C31G03	—	CLE	8.3	20E
5980C99G04	8CLE-25E-D	5981C31G04	—	CLE	8.3	25E
5980C99G05	8CLE-30E	5981C31G05	—	CLE	8.3	30E
5981C01G01	15HLE-10E	5981C32G01	—	HLE	15.5	10E
5981C01G02	15HLE-15E	5981C32G02	—	HLE	15.5	15E
5981C01G03	15HLE-20E	5981C32G03	—	HLE	15.5	20E
5981C01G04	15HLE-25E	5981C32G04	—	HLE	15.5	25E
5981C01G05	15HLE-30E	5981C32G05	—	HLE	15.5	30E
5981C02G01	15CLE-10E-D	5981C33G01	—	CLE	15.5	10E
5981C02G02	15CLE-15E-D	5981C33G02	—	CLE	15.5	15E
5981C02G03	15CLE-20E-D	5981C33G03	—	CLE	15.5	20E
5981C02G04	15CLE-25E-D	5981C33G04	—	CLE	15.5	25E
5981C02G05	15CLE-30E	5981C33G05	—	CLE	15.5	30E
5981C03G01	5HLE-PDM-D	5981C03G01	—	HLE	5.5	250
5981C03G02	8HLE-PDM-D	5981C03G02	—	HLE	8.3	175
5981C03G03	15HLE-PDM-D	5981C03G03	—	HLE	15.5	125
5981C03G04	5HLE-GDM-D	5981C03G04	—	HLE	5.5	250
5981C03G05	8HLE-GDM-D	5981C03G05	—	HLE	8.3	175
5981C03G06	15HLE-GDM-D	5981C03G06	—	HLE	15.5	125
5981C03G07	5HLE-PNM-D	5981C03G07	—	HLE	5.5	250
5981C03G08	8HLE-PNM-D	5981C03G08	—	HLE	8.3	175
5981C03G09	15HLE-PNM-D	5981C03G09	—	HLE	15.5	125
5981C03G10	5HLE-GNM-D	5981C03G10	—	HLE	5.5	25
5981C03G11	8HLE-GNM-D	5981C03G11	—	HLE	8.3	175
5981C03G12	15HLE-GNM-D	5981C03G12	—	HLE	15.5	125
5981C03G13	5HLE-PDM-E	5981C03G13	—	HLE	5.5	450
5981C03G14	8HLE-PDM-E	5981C03G14	—	HLE	8.3	350
5981C03G15	15HLE-PDM-E	5981C03G15	—	HLE	15.5	250
5981C03G16	5HLE-GDM-E	5981C03G16	—	HLE	5.5	450
5981C03G17	8HLE-GDM-E	5981C03G17	—	HLE	8.3	350
5981C03G18	15HLE-GDM-E	5981C03G18	—	HLE	15.5	250
5981C03G19	5HLE-PNM-E	5981C03G19	—	HLE	5.5	450
5981C03G20	8HLE-PNM-E	5981C03G20	—	HLE	8.3	350
5981C03G21	15HLE-PNM-E	5981C03G21	—	HLE	15.5	250
5981C03G22	5HLE-GNM-E	5981C03G22	—	HLE	5.5	450
5981C03G23	8HLE-GNM-E	5981C03G23	—	HLE	8.3	350
5981C03G24	15HLE-GNM-E	5981C03G24	—	HLE	15.5	250
5981G05G01	5NCLPT-10E	5981G05G01	—	CLPT	5.5	10E
5981G05G02	5NCLPT-5E	5981G05G02	—	CLPT	5.5	5E
5981G05G03	5NCLPT-3E	5981G05G03	—	CLPT	5.5	3E
5981G05G04	5NCLPT-2E	5981G05G04	—	CLPT	5.5	2E
5981G05G05	5NCLPT-1E	5981G05G05	—	CLPT	5.5	1E
5981G05G06	5NCLPT-0.5E	5981G05G06	—	CLPT	5.5	0.5E
5981C06G01	8NCLPT-10E	5981C06G01	—	CLPT	8.3	10E
5981C06G02	8NCLPT-5E	5981C06G02	—	CLPT	8.3	5E

Appendix 2—Superseded Style Number Index

Old 10 Digit Style Number	Current Eaton Catalog Number	Eaton 10 Digit Style Number	Description	Type	Voltage Rating kV Max.	Current Rating Amperes
5981C06G03	8NCLPT-3E	5981C06G03	—	CLPT	8.3	3E
5981C06G04	8NCLPT-2E	5981C06G04	—	CLPT	8.3	2E
5981C06G05	8NCLPT-1E	5981C06G05	—	CLPT	8.3	1E
5981C06G06	8NCLPT-0.5E	5981C06G06	—	CLPT	8.3	0.5E
5981C07G01	15NCLPT-10E	5981C07G01	—	CLPT	15.5	10E
5981C07G02	15NCLPT-5E	5981C07G02	—	CLPT	15.5	5E
5981C07G03	15NCLPT-3E	5981C07G03	—	CLPT	15.5	3E
5981C07G04	15NCLPT-2E	5981C07G04	—	CLPT	15.5	2E
5981C07G05	15NCLPT-1E	5981C07G05	—	CLPT	15.5	1E
5981C07G06	15NCLPT-0.5E	5981C07G06	—	CLPT	15.5	0.5E
5981C14G01	5HLE-30E	5981C28G05	—	HLE	5.5	30E
5981C14G02	5HLE-40E	5981C64G01	—	HLE	5.5	40E
5981C14G03	5HLE-50E	5981C64G02	—	HLE	5.5	50E
5981C14G04	5HLE-65E	5981C64G03	—	HLE	5.5	65E
5981C14G05	5HLE-80E	5981C64G04	—	HLE	5.5	80E
5981C14G06	5HLE-100E	5981C64G05	—	HLE	5.5	100E
5981C14G07	5HLE-125E	5981C64G06	—	HLE	5.5	125E
5981C14G08	5HLE-150E	5981C64G07	—	HLE	5.5	150E
5981C14G09	5HLE-175E	5981C64G08	—	HLE	5.5	175E
5981C14G10	5HLE-200E	5981C64G09	—	HLE	5.5	200E
5981C14G11	5HLE-250E	5981C64G10	—	HLE	5.5	250E
5981C15G01	5CLE-30E	5981C29G05	—	CLE	5.5	30E
5981C15G02	5CLE-40E	5981C65G01	—	CLE	5.5	40E
5981C15G03	5CLE-50E	5981C65G02	—	CLE	5.5	50E
5981C15G04	5CLE-65E	5981C65G03	—	CLE	5.5	65E
5981C15G05	5CLE-80E	5981C65G04	—	CLE	5.5	80E
5981C15G06	5CLE-100E	5981C65G05	—	CLE	5.5	100E
5981C15G07	5CLE-125E	5981C65G06	—	CLE	5.5	125E
5981C15G08	5CLE-150E	5981C65G07	—	CLE	5.5	150E
5981C15G09	5CLE-175E	5981C65G08	—	CLE	5.5	175E
5981C15G10	5CLE-200E	5981C65G09	—	CLE	5.5	200E
5981C15G11	5CLE-250E	5981C65G10	—	CLE	5.5	250E
5981C16G04	8HLE-40E	5981C16G04	—	HLE	8.3	40E
5981C16G05	8HLE-50E	5981C16G05	—	HLE	8.3	50E
5981C16G06	8HLE-65E	5981C16G06	—	HLE	8.3	65E
5981C16G07	8HLE-80E	5981C16G07	—	HLE	8.3	80E
5981C16G08	8HLE-100E	5981C16G08	—	HLE	8.3	100E
5981C16G09	8HLE-125E	5981C16G09	—	HLE	8.3	125E
5981C16G10	8HLE-150E	5981C16G10	—	HLE	8.3	150E
5981C16G11	8HLE-175E	5981C16G11	—	HLE	8.3	175E
5981C17G04	8CLE-40E	5981C17G04	—	CLE	8.3	40E
5981C17G05	8CLE-50E	5981C17G05	—	CLE	8.3	50E
5981C17G06	8CLE-65E	5981C17G06	—	CLE	8.3	65E
5981C17G07	8CLE-80E	5981C17G07	—	CLE	8.3	80E
5981C17G08	8CLE-100E	5981C17G08	—	CLE	8.3	100E
5981C17G09	8CLE-125E	5981C17G09	—	CLE	8.3	125E
5981C17G10	8CLE-150E	5981C17G10	—	CLE	8.3	150E
5981C17G11	8CLE-175E	5981C17G11	—	CLE	8.3	175E
5981C18G05	15HLE-40E	5981C18G05	—	HLE	15.5	40E
5981C18G06	15HLE-50E	5981C18G06	—	HLE	15.5	50E
5981C18G07	15HLE-65E	5981C18G07	—	HLE	15.5	65E
5981C18G08	15HLE-80E	5981C18G08	—	HLE	15.5	80E
5981C18G09	15HLE-100E	5981C18G09	—	HLE	15.5	100E

Appendix 2—Superseded Style Number Index

Old 10 Digit Style Number	Current Eaton Catalog Number	Eaton 10 Digit Style Number	Description	Type	Voltage Rating kV Max.	Current Rating Amperes
5981C18G10	15HLE-125E	5981C18G10	—	HLE	15.5	125E
5981C19G04	15CLE-40E	5981C19G04	—	CLE	15.5	40E
5981C19G05	15CLE-50E	5981C19G05	—	CLE	15.5	50E
5981C19G06	15CLE-65E	5981C19G06	—	CLE	15.5	65E
5981C19G07	15CLE-80E	5981C19G07	—	CLE	15.5	80E
5981C19G08	15CLE-100E	5981C19G08	—	CLE	15.5	100E
5981C19G09	15CLE-125E	5981C19G09	—	CLE	15.5	125E
5981C19G10	15CLE-150E	5981C19G10	—	CLE	15.5	150E
5981C20G01	5HLE-300E	5981C66G01	—	HLE	5.5	300E
5981C20G02	5HLE-350E	5981C66G02	—	HLE	5.5	350E
5981C20G03	5HLE-400E	5981C66G03	—	HLE	5.5	400E
5981C20G04	5HLE-450E	5981C66G04	—	HLE	5.5	450E
5981C21G01	5CLE-300E	5981C67G01	—	CLE	5.5	300E
5981C21G02	5CLE-350E	5981C67G02	—	CLE	5.5	350E
5981C21G03	5CLE-400E	5981C67G03	—	CLE	5.5	400E
5981C21G04	5CLE-450E	5981C67G04	—	CLE	5.5	450E
5981C22G01	8CLE-200E	5981C22G01	—	CLE	8.3	200E
5981C22G02	8CLE-250E	5981C22G02	—	CLE	8.3	250E
5981C22G03	8CLE-300E	5981C22G03	—	CLE	8.3	300E
5981C22G04	8CLE-350E	5981C22G04	—	CLE	8.3	350E
5981C23G01	8HLE-200E	5981C23G01	—	HLE	8.3	200E
5981C23G02	8HLE-250E	5981C23G02	—	HLE	8.3	250E
5981C23G03	8HLE-300E	5981C23G03	—	HLE	8.3	300E
5981C23G04	8HLE-350E	5981C23G04	—	HLE	8.3	350E
5981C24G01	15CLE-175E	5981C24G01	—	CLE	15.5	175E
5981C24G02	15CLE-200E	5981C24G02	—	CLE	15.5	200E
5981C24G03	15CLE-250E	5981C24G03	—	CLE	15.5	250E
5981C24G04	15CLE-300E	5981C24G04	—	CLE	15.5	300E
5981C25G01	15HLE-150E	5981C25G01	—	HLE	15.5	150E
5981C25G02	15HLE-175E	5981C25G02	—	HLE	15.5	175E
5981C25G03	15HLE-200E	5981C25G03	—	HLE	15.5	200E
5981C25G04	15HLE-250E	5981C25G04	—	HLE	15.5	250E
5981C27G01	2ACLS-4L	5981C27G01	Conducting link	CLS	2.54	450
5981C27G02	8ACLS-4L	5981C27G02	Conducting link	CLS	8.3	480
5981C27G03	2BCLS-4L	5981C27G03	Conducting link	CLS	2.54	450
5981C27G04	8BCLS-4L	5981C27G04	Conducting link	CLS	8.3	480
5981C27G05	8HLE-CL	5981C27G05	Conducting link	HLE	8.3	350
5981C27G06	8CLE-CL	5981C27G06	Conducting link	CLE	8.3	350
5981C27G07	15HLE-CL	5981C27G07	Conducting link	HLE	15.5	250
5981C27G08	15CLE-CL	5981C27G08	Conducting link	CLE	15.5	300
5981C28G01	5HLE-10E	5981C28G01	—	HLE	5.5	10E
5981C28G02	5HLE-15E	5981C28G02	—	HLE	5.5	15E
5981C28G03	5HLE-20E	5981C28G03	—	HLE	5.5	20E
5981C28G04	5HLE-25E	5981C28G04	—	HLE	5.5	25E
5981C28G05	5HLE-30E	5981C28G05	—	HLE	5.5	30E
5981C29G01	5CLE-10E-D	5981C29G01	—	CLE	5.5	10E
5981C29G02	5CLE-15E-D	5981C29G02	—	CLE	5.5	15E
5981C29G03	5CLE-20E-D	5981C29G03	—	CLE	5.5	20E
5981C29G04	5CLE-25E-D	5981C29G04	—	CLE	5.5	25E
5981C29G05	5CLE-30E	5981C29G05	—	CLE	5.5	30E
5981C30G01	8HLE-10E	5981C30G01	—	HLE	8.3	10E
5981C30G02	8HLE-15E	5981C30G02	—	HLE	8.3	15E
5981C30G03	8HLE-20E	5981C30G03	—	HLE	8.3	20E

Appendix 2—Superseded Style Number Index

Old 10 Digit Style Number	Current Eaton Catalog Number	Eaton 10 Digit Style Number	Description	Type	Voltage Rating kV Max.	Current Rating Amperes
5981C30G04	8HLE-25E	5981C30G04	—	HLE	8.3	25E
5981C30G05	8HLE-30E	5981C30G05	—	HLE	8.3	30E
5981C31G01	8CLE-10E-D	5981C31G01	—	CLE	8.3	10E
5981C31G02	8CLE-15E-D	5981C31G02	—	CLE	8.3	15E
5981C31G03	8CLE-20E-D	5981C31G03	—	CLE	8.3	20E
5981C31G04	8CLE-25E-D	5981C31G04	—	CLE	8.3	25E
5981C31G05	8CLE-30E	5981C31G05	—	CLE	8.3	30E
5981C32G01	15HLE-10E	5981C32G01	—	HLE	15.5	10E
5981C32G02	15HLE-15E	5981C32G02	—	HLE	15.5	15E
5981C32G03	15HLE-20E	5981C32G03	—	HLE	15.5	20E
5981C32G04	15HLE-25E	5981C32G04	—	HLE	15.5	25E
5981C32G05	15HLE-30E	5981C32G05	—	HLE	15.5	30E
5981C33G01	15CLE-10E-D	5981C33G01	—	CLE	15.5	10E
5981C33G02	15CLE-15E-D	5981C33G02	—	CLE	15.5	15E
5981C33G03	15CLE-20E-D	5981C33G03	—	CLE	15.5	20E
5981C33G04	15CLE-25E-D	5981C33G04	—	CLE	15.5	25E
5981C33G05	15CLE-30E	5981C33G05	—	CLE	15.5	30E
5981C40G01	8AHLE-20E	5981C47G03	—	HLE	8.3	20E
5981C40G02	8AHLE-25E	5981C47G04	—	HLE	8.3	25E
5981C40G03	8AHLE-30E	5981C47G05	—	HLE	8.3	30E
5981C40G04	8AHLE-40E	5981C47G06	—	HLE	8.3	40E
5981C40G05	8AHLE-50E	5981C47G07	—	HLE	8.3	50E
5981C40G06	8AHLE-65E	5981C47G08	—	HLE	8.3	65E
5981C40G07	8AHLE-80E	5981C47G09	—	HLE	8.3	80E
5981C40G08	8AHLE-100E	5981C47G10	—	HLE	8.3	100E
5981C40G09	8AHLE-125E	5981C47G11	—	HLE	8.3	125E
5981C40G10	8AHLE-150E	5981C47G12	—	HLE	8.3	150E
5981C40G11	8AHLE-175E	5981C47G13	—	HLE	8.3	175E
5981C41G01	8AHLE-200E	5981C47G14	—	HLE	8.3	200E
5981C41G02	8AHLE-250E	5981C47G15	—	HLE	8.3	250E
5981C41G03	8AHLE-300E	5981C47G16	—	HLE	8.3	300E
5981C41G04	8AHLE-350E	5981C47G17	—	HLE	8.3	350E
5981C46G01	5AHLE-10E	5981C46G01	—	HLE	5.5	10E
5981C46G02	5AHLE-15E	5981C46G02	—	HLE	5.5	15E
5981C46G03	5AHLE-20E	5981C46G03	—	HLE	5.5	20E
5981C46G04	5AHLE-25E	5981C46G04	—	HLE	5.5	25E
5981C46G05	5AHLE-30E	5981C46G05	—	HLE	5.5	30E
5981C46G06	5AHLE-40E	5981C46G06	—	HLE	5.5	40E
5981C46G07	5AHLE-50E	5981C46G07	—	HLE	5.5	50E
5981C46G08	5AHLE-65E	5981C46G08	—	HLE	5.5	65E
5981C46G09	5AHLE-80E	5981C46G09	—	HLE	5.5	80E
5981C46G10	5AHLE-100E	5981C46G10	—	HLE	5.5	100E
5981C46G11	5AHLE-125E	5981C46G11	—	HLE	5.5	125E
5981C46G12	5AHLE-150E	5981C46G12	—	HLE	5.5	150E
5981C46G13	5AHLE-175E	5981C46G13	—	HLE	5.5	175E
5981C46G14	5AHLE-200E	5981C46G14	—	HLE	5.5	200E
5981C46G15	5AHLE-250E	5981C46G15	—	HLE	5.5	250E
5981C46G16	5AHLE-300E	5981C46G16	—	HLE	5.5	300E
5981C46G17	5AHLE-350E	5981C46G17	—	HLE	5.5	350E
5981C46G18	5AHLE-400E	5981C46G18	—	HLE	5.5	400E
5981C46G19	5AHLE-450E	5981C46G19	—	HLE	5.5	450E
5981C47G01	8AHLE-10E	5981C47G01	—	HLE	8.3	10E
5981C47G02	8AHLE-15E	5981C47G02	—	HLE	8.3	15E

Appendix 2—Superseded Style Number Index

Old 10 Digit Style Number	Current Eaton Catalog Number	Eaton 10 Digit Style Number	Description	Type	Voltage Rating kV Max.	Current Rating Amperes
5981C47G03	8AHLE-20E	5981C47G03	—	HLE	8.3	20E
5981C47G04	8AHLE-25E	5981C47G04	—	HLE	8.3	25E
5981C47G05	8AHLE-30E	5981C47G05	—	HLE	8.3	30E
5981C47G06	8AHLE-40E	5981C47G06	—	HLE	8.3	40E
5981C47G07	8AHLE-50E	5981C47G07	—	HLE	8.3	50E
5981C47G08	8AHLE-65E	5981C47G08	—	HLE	8.3	65E
5981C47G09	8AHLE-80E	5981C47G09	—	HLE	8.3	80E
5981C47G10	8AHLE-100E	5981C47G10	—	HLE	8.3	100E
5981C47G11	8AHLE-125E	5981C47G11	—	HLE	8.3	125E
5981C47G12	8AHLE-150E	5981C47G12	—	HLE	8.3	150E
5981C47G13	8AHLE-175E	5981C47G13	—	HLE	8.3	175E
5981C47G14	8AHLE-200E	5981C47G14	—	HLE	8.3	200E
5981C47G15	8AHLE-250E	5981C47G15	—	HLE	8.3	250E
5981C47G16	8AHLE-300E	5981C47G16	—	HLE	8.3	300E
5981C47G17	8AHLE-350E	5981C47G17	—	HLE	8.3	350E
5981C48G01	5AHLE-10E	5981C46G01	—	HLE	5.5	10E
5981C48G02	5AHLE-15E	5981C46G02	—	HLE	5.5	15E
5981C48G03	5AHLE-20E	5981C46G03	—	HLE	5.5	20E
5981C48G04	5AHLE-25E	5981C46G04	—	HLE	5.5	25E
5981C48G05	5AHLE-30E	5981C46G05	—	HLE	5.5	30E
5981C49G01	8AHLE-10E	5981C47G01	—	HLE	8.3	10E
5981C49G02	8AHLE-15E	5981C47G02	—	HLE	8.3	15E
5981C49G03	8AHLE-20E	5981C47G03	—	HLE	8.3	20E
5981C49G04	8AHLE-25E	5981C47G04	—	HLE	8.3	25E
5981C49G05	8AHLE-30E	5981C47G05	—	HLE	8.3	30E
5981C50G01	8RBA2-IDH	5981C50G01	—	RBA2	8.3	200
5981C50G02	15RBA2-IDH	5981C50G02	—	RBA2	15.5	200
5981C50G03	25RBA2-IDH	5981C50G03	—	RBA2	25.5	200
5981C50G04	38RBA2-IDH	5981C50G04	—	RBA2	38	200
5981C50G05	8RBA2-ILBDH	5981C50G05	—	RBA2	8.3	200
5981C50G06	15RBA2-ILBDH	5981C50G06	—	RBA2	15.5	200
5981C50G07	25RBA2-ILBDH	5981C50G07	—	RBA2	25.5	200
5981C51G01	8RBA2-INH	5981C51G01	—	RBA2	8.3	200
5981C51G02	15RBA2-INH	5981C51G02	—	RBA2	15.5	200
5981C51G03	25RBA2-INH	5981C51G03	—	RBA2	25.5	200
5981C51G04	38RBA2-INH	5981C51G04	—	RBA2	38	200
5981C52G01	8RBA4-IDH	5981C52G01	—	RBA4	8.3	400
5981C52G02	15RBA4-IDH	5981C52G02	—	RBA4	15.5	400
5981C52G03	25RBA4-IDH	5981C52G03	—	RBA4	25.5	300
5981C52G04	38RBA4-IDH	5981C52G04	—	RBA4	38	300
5981C52G05	8RBA4-ILBDH	5981C52G05	—	RBA4	8.3	400
5981C52G06	15RBA4-ILBDH	5981C52G06	—	RBA4	15.5	400
5981C52G07	25RBA4-ILBDH	5981C52G07	—	RBA4	25.5	300
5981C53G01	8RBA4-INH	5981C53G01	—	RBA4	8.3	400
5981C53G02	15RBA4-INH	5981C53G02	—	RBA4	15.5	400
5981C53G03	25RBA4-INH	5981C53G03	—	RBA4	25.5	300
5981C53G04	38RBA4-INH	5981C53G04	—	RBA4	38	300
5981C54G01	8RBA8-INH	5981C54G01	—	RBA4	8.3	720
5981C54G02	15RBA8-INH	5981C54G02	—	RBA4	15.5	720
5981C54G03	25RBA8-INH	5981C54G03	—	RBA4	25.5	540
5981C54G04	38RBA8-INH	5981C54G04	—	RBA4	38	540
5981C58G01	5BHCL-750E	5981C58G01	—	HCL	5.5	750E
5981C58G02	5BHCL-900E	5981C58G02	—	HCL	5.5	900E

Appendix 2—Superseded Style Number Index

Old 10 Digit Style Number	Current Eaton Catalog Number	Eaton 10 Digit Style Number	Description	Type	Voltage Rating kV Max.	Current Rating Amperes
5981C61G01	15HCL-250E	5981C61G01	—	HCL	15.5	250E
5981C61G02	15HCL-300E	5981C61G02	—	HCL	15.5	300E
5981C61G03	15HCL-200E	5981C61G03	—	HCL	15.5	200E
5981C61G04	15HCL-150E	5981C61G04	—	HCL	15.5	150E
5981C61G05	15HCL-175E	5981C61G05	—	HCL	15.5	175E
5981C61G06	15BHCL-300E	5981C61G06	—	HCL	15.5	300E
5981C62G01	5HCL-500E	5981C62G01	—	HCL	5.5	500E
5981C62G02	5HCL-600E	5981C62G02	—	HCL	5.5	600E
5981C62G03	5HCL-450E	5981C62G03	—	HCL	5.5	450E
5981C62G04	5HCL-400E	5981C62G04	—	HCL	5.5	400E
5981C62G05	5HCL-300E	5981C62G05	—	HCL	5.5	300E
5981C62G06	5HCL-250E	5981C62G06	—	HCL	5.5	250E
5981C62G07	5HCL-200E	5981C62G07	—	HCL	5.5	200E
5981C62G08	5BHCL-600E	5981C62G08	—	HCL	5.5	600E
5981C62G09	5BHCL-500E	5981C62G09	—	HCL	5.5	500E
5981C62G10	5BHCL-450E	5981C62G10	—	HCL	5.5	450E
5981C62G11	5BHCL-400E	5981C62G11	—	HCL	5.5	400E
5981C62G12	5BHCL-300E	5981C62G12	—	HCL	5.5	300E
5981C62G13	5BHCL-250E	5981C62G13	—	HCL	5.5	250E
5981C62G14	5BHCL-200E	5981C62G14	—	HCL	5.5	200E
5981C64G01	5HLE-40E	5981C64G01	—	HLE	5.5	40E
5981C64G02	5HLE-50E	5981C64G02	—	HLE	5.5	50E
5981C64G03	5HLE-65E	5981C64G03	—	HLE	5.5	65E
5981C64G04	5HLE-80E	5981C64G04	—	HLE	5.5	80E
5981C64G05	5HLE-100E	5981C64G05	—	HLE	5.5	100E
5981C64G06	5HLE-125E	5981C64G06	—	HLE	5.5	125E
5981C64G07	5HLE-150E	5981C64G07	—	HLE	5.5	150E
5981C64G08	5HLE-175E	5981C64G08	—	HLE	5.5	175E
5981C64G09	5HLE-200E	5981C64G09	—	HLE	5.5	200E
5981C64G10	5HLE-250E	5981C64G10	—	HLE	5.5	250E
5981C65G1	5CLE-40E	5981C65G01	—	CLE	5.5	40E
5981C65G2	5CLE-50E	5981C65G02	—	CLE	5.5	50E
5981C65G3	5CLE-65E	5981C65G03	—	CLE	5.5	65E
5981C65G4	5CLE-80E	5981C65G04	—	CLE	5.5	80E
5981C65G5	5CLE-100E	5981C65G05	—	CLE	5.5	100E
5981C65G6	5CLE-125E	5981C65G06	—	CLE	5.5	125E
5981C65G7	5CLE-150E	5981C65G07	—	CLE	5.5	150E
5981C65G8	5CLE-175E	5981C65G08	—	CLE	5.5	175E
5981C65G9	5CLE-200E	5981C65G09	—	CLE	5.5	200E
5981C65G10	5CLE-250E	5981C65G10	—	CLE	5.5	250E
5981C66G01	5HLE-300E	5981C66G01	—	HLE	5.5	300E
5981C66G02	5HLE-350E	5981C66G02	—	HLE	5.5	350E
5981C66G03	5HLE-400E	5981C66G03	—	HLE	5.5	400E
5981C66G04	5HLE-450E	5981C66G04	—	HLE	5.5	450E
5981C67G01	5CLE-300E	5981C67G01	—	CLE	5.5	300E
5981C67G02	5CLE-350E	5981C67G02	—	CLE	5.5	350E
5981C67G03	5CLE-400E	5981C67G03	—	CLE	5.5	400E
5981C67G04	5CLE-450E	5981C67G04	—	CLE	5.5	450E
5981C68G01	15HCL-125E	5981C68G01	—	HCL	15.5	125E
5981C68G02	15HCL-100E	5981C68G02	—	HCL	15.5	100E
5981C68G03	15HCL-80E	5981C68G03	—	HCL	15.5	80E
5981C68G04	15HCL-65E	5981C68G04	—	HCL	15.5	65E
5981C69G02	DBU-MFLR	5981C69G02	—	DBU	—	200

Appendix 2—Superseded Style Number Index

Old 10 Digit Style Number	Current Eaton Catalog Number	Eaton 10 Digit Style Number	Description	Type	Voltage Rating kV Max.	Current Rating Amperes
5981C75G01	17DBU-3K	5981C75G01	—	DBU	17	3K
5981C75G02	17DBU-6K	5981C75G02	—	DBU	17	6K
5981C75G03	17DBU-8K	5981C75G03	—	DBU	17	8K
5981C75G04	17DBU-10K	5981C75G04	—	DBU	17	10K
5981C75G05	17DBU-12K	5981C75G05	—	DBU	17	12K
5981C75G06	17DBU-15K	5981C75G06	—	DBU	17	15K
5981C75G07	17DBU-20K	5981C75G07	—	DBU	17	20K
5981C75G08	17DBU-25K	5981C75G08	—	DBU	17	25K
5981C75G09	17DBU-30K	5981C75G09	—	DBU	17	30K
5981C75G10	17DBU-40K	5981C75G10	—	DBU	17	40K
5981C75G11	17DBU-50K	5981C75G11	—	DBU	17	50K
5981C75G12	17DBU-65K	5981C75G12	—	DBU	17	65K
5981C75G13	17DBU-80K	5981C75G13	—	DBU	17	80K
5981C75G14	17DBU-100K	5981C75G14	—	DBU	17	100K
5981C75G15	17DBU-140K	5981C75G15	—	DBU	17	140K
5981C75G16	17DBU-200K	5981C75G16	—	DBU	17	200K
5981C76G01	17DBU-5E	5981C76G01	—	DBU	17	5E
5981C76G02	17DBU-7E	5981C76G02	—	DBU	17	7E
5981C76G03	17DBU-10E	5981C76G03	—	DBU	17	10E
5981C76G04	17DBU-12E	5981C76G04	—	DBU	17	12E
5981C76G05	17DBU-15E	5981C76G05	—	DBU	17	15E
5981C76G06	17DBU-20E	5981C76G06	—	DBU	17	20E
5981C76G07	17DBU-25E	5981C76G07	—	DBU	17	25E
5981C76G08	17DBU-30E	5981C76G08	—	DBU	17	30E
5981C76G09	17DBU-40E	5981C76G09	—	DBU	17	40E
5981C76G10	17DBU-50E	5981C76G10	—	DBU	17	50E
5981C76G11	17DBU-65E	5981C76G11	—	DBU	17	65E
5981C76G12	17DBU-80E	5981C76G12	—	DBU	17	80E
5981C76G13	17DBU-100E	5981C76G13	—	DBU	17	100E
5981C76G14	17DBU-125E	5981C76G14	—	DBU	17	125E
5981C76G15	17DBU-150E	5981C76G15	—	DBU	17	150E
5981C76G16	17DBU-175E	5981C76G16	—	DBU	17	175E
5981C76G17	17DBU-200E	5981C76G17	—	DBU	17	200E
5981C77G01	17DBU-15SE	5981C77G01	—	DBU	17	15SE
5981C77G02	17DBU-20SE	5981C77G02	—	DBU	17	20SE
5981C77G03	17DBU-25SE	5981C77G03	—	DBU	17	25SE
5981C77G04	17DBU-30SE	5981C77G04	—	DBU	17	30SE
5981C77G05	17DBU-40SE	5981C77G05	—	DBU	17	40SE
5981C77G06	17DBU-50SE	5981C77G06	—	DBU	17	50SE
5981C77G07	17DBU-65SE	5981C77G07	—	DBU	17	65SE
5981C77G08	17DBU-80SE	5981C77G08	—	DBU	17	80SE
5981C77G09	17DBU-100SE	5981C77G09	—	DBU	17	100SE
5981C77G10	17DBU-125SE	5981C77G10	—	DBU	17	125SE
5981C77G11	17DBU-150SE	5981C77G11	—	DBU	17	150SE
5981C77G12	17DBU-175SE	5981C77G12	—	DBU	17	175SE
5981C77G13	17DBU-200SE	5981C77G13	—	DBU	17	200SE
5981C85G01	27DBU-3K	5981C85G01	—	DBU	27	3K
5981C85G02	27DBU-6K	5981C85G02	—	DBU	27	6K
5981C85G03	27DBU-8K	5981C85G03	—	DBU	27	8K
5981C85G04	27DBU-10K	5981C85G04	—	DBU	27	10K
5981C85G05	27DBU-12K	5981C85G05	—	DBU	27	12K
5981C85G06	27DBU-15K	5981C85G06	—	DBU	27	15K
5981C85G07	27DBU-20K	5981C85G07	—	DBU	27	20K

Appendix 2—Superseded Style Number Index

Old 10 Digit Style Number	Current Eaton Catalog Number	Eaton 10 Digit Style Number	Description	Type	Voltage Rating kV Max.	Current Rating Amperes
5981C85G08	27DBU-25K	5981C85G08	—	DBU	27	25K
5981C85G09	27DBU-30K	5981C85G09	—	DBU	27	30K
5981C85G10	27DBU-40K	5981C85G10	—	DBU	27	40K
5981C85G11	27DBU-50K	5981C85G11	—	DBU	27	50K
5981C85G12	27DBU-65K	5981C85G12	—	DBU	27	65K
5981C85G13	27DBU-80K	5981C85G13	—	DBU	27	80K
5981C85G14	27DBU-100K	5981C85G14	—	DBU	27	100K
5981C85G15	27DBU-140K	5981C85G15	—	DBU	27	140K
5981C85G16	27DBU-200K	5981C85G16	—	DBU	27	200K
5981C86G01	27DBU-5E	5981C86G01	—	DBU	27	5E
5981C86G02	27DBU-7E	5981C86G02	—	DBU	27	7E
5981C86G03	27DBU-10E	5981C86G03	—	DBU	27	10E
5981C86G04	27DBU-12E	5981C86G04	—	DBU	27	12E
5981C86G05	27DBU-15E	5981C86G05	—	DBU	27	15E
5981C86G06	27DBU-20E	5981C86G06	—	DBU	27	20E
5981C86G07	27DBU25E	5981C86G07	—	DBU	27	25E
5981C86G08	27DBU-30E	5981C86G08	—	DBU	27	30E
5981C86G09	27DBU-40E	5981C86G09	—	DBU	27	40E
5981C86G10	27DBU-50E	5981C86G10	—	DBU	27	50E
5981C86G11	27DBU-65E	5981C86G11	—	DBU	27	65E
5981C86G12	27DBU-80E	5981C86G12	—	DBU	27	80E
5981C86G13	27DBU-100E	5981C86G13	—	DBU	27	100E
5981C86G14	27DBU-125E	5981C86G14	—	DBU	27	125E
5981C86G15	27DBU-150E	5981C86G15	—	DBU	27	150E
5981C86G16	27DBU-175E	5981C86G16	—	DBU	27	175E
5981C86G17	27DBU-200E	5981C86G17	—	DBU	27	200E
5981C87G01	27DBU-15SE	5981C87G01	—	DBU	27	15SE
5981C87G02	27DBU-20SE	5981C87G02	—	DBU	27	20SE
5981C87G03	27DBU25SE	5981C87G03	—	DBU	27	25SE
5981C87G04	27DBU-30SE	5981C87G04	—	DBU	27	30SE
5981C87G05	27DBU-40SE	5981C87G05	—	DBU	27	40SE
5981C87G06	27DBU-50SE	5981C87G06	—	DBU	27	50SE
5981C87G07	27DBU-65SE	5981C87G07	—	DBU	27	65SE
5981C87G08	27DBU-80SE	5981C87G08	—	DBU	27	80SE
5981C87G09	27DBU-100SE	5981C87G09	—	DBU	27	100SE
5981C87G10	27DBU-125SE	5981C87G10	—	DBU	27	125SE
5981C87G11	27DBU-150SE	5981C87G11	—	DBU	27	150SE
5981C87G12	27DBU-175SE	5981C87G12	—	DBU	27	175SE
5981C87G13	27DBU-200SE	5981C87G13	—	DBU	27	200SE
5981C95G01	38DBU-3K	5981C95G01	—	DBU	38	3K
5981C95G02	38DBU-6K	5981C95G02	—	DBU	38	6K
5981C95G03	38DBU-8K	5981C95G03	—	DBU	38	8K
5981C95G04	38DBU-10K	5981C95G04	—	DBU	38	10K
5981C95G05	38DBU-12K	5981C95G05	—	DBU	38	12K
5981C95G06	38DBU-15K	5981C95G06	—	DBU	38	15K
5981C95G07	38DBU-20K	5981C95G07	—	DBU	38	20K
5981C95G08	38DBU-25K	5981C95G08	—	DBU	38	25K
5981C95G09	38DBU-30K	5981C95G09	—	DBU	38	30K
5981C95G10	38DBU-40K	5981C95G10	—	DBU	38	40K
5981C95G11	38DBU-50K	5981C95G11	—	DBU	38	50K
5981C95G12	38DBU-65K	5981C95G12	—	DBU	38	65K
5981C95G13	38DBU-80K	5981C95G13	—	DBU	38	80K
5981C95G14	38DBU-100K	5981C95G14	—	DBU	38	100K

Appendix 2—Superseded Style Number Index

Old 10 Digit Style Number	Current Eaton Catalog Number	Eaton 10 Digit Style Number	Description	Type	Voltage Rating kV Max.	Current Rating Amperes
5981C95G15	38DBU-140K	5981C95G15	—	DBU	38	140K
5981C95G16	38DBU-200K	5981C95G16	—	DBU	38	200K
5981C96G01	38DBU-5E	5981C96G01	—	DBU	38	5E
5981C96G02	38DBU-7E	5981C96G02	—	DBU	38	7E
5981C96G03	38DBU-10E	5981C96G03	—	DBU	38	10E
5981C96G04	38DBU-12E	5981C96G04	—	DBU	38	12E
5981C96G05	38DBU-15E	5981C96G05	—	DBU	38	15E
5981C96G06	38DBU-20E	5981C96G06	—	DBU	38	20E
5981C96G07	38DBU-25E	5981C96G07	—	DBU	38	25E
5981C96G08	38DBU-30E	5981C96G08	—	DBU	38	30E
5981C96G09	38DBU-40E	5981C96G09	—	DBU	38	40E
5981C96G10	38DBU-50E	5981C96G10	—	DBU	38	50E
5981C96G11	38DBU-65E	5981C96G11	—	DBU	38	65E
5981C96G12	38DBU-80E	5981C96G12	—	DBU	38	80E
5981C96G13	38DBU-100E	5981C96G13	—	DBU	38	100E
5981C96G14	38DBU-125E	5981C96G14	—	DBU	38	125E
5981C96G15	38DBU-150E	5981C96G15	—	DBU	38	150E
5981C96G16	38DBU-175E	5981C96G16	—	DBU	38	175E
5981C96G17	38DBU-200E	5981C96G17	—	DBU	38	200E
5981C97G01	38DBU-15SE	5981C97G01	—	DBU	38	15SE
5981C97G02	38DBU-20SE	5981C97G02	—	DBU	38	20SE
5981C97G03	38DBU-25SE	5981C97G03	—	DBU	38	25SE
5981C97G04	38DBU-30SE	5981C97G04	—	DBU	38	30SE
5981C97G05	38DBU-40SE	5981C97G05	—	DBU	38	40SE
5981C97G06	38DBU-50SE	5981C97G06	—	DBU	38	50SE
5981C97G07	38DBU-65SE	5981C97G07	—	DBU	38	65SE
5981C97G08	38DBU-80SE	5981C97G08	—	DBU	38	80SE
5981C97G09	38DBU-100SE	5981C97G09	—	DBU	38	100SE
5981C97G10	38DBU-125SE	5981C97G10	—	DBU	38	125SE
5981C97G11	38DBU-150SE	5981C97G11	—	DBU	38	150SE
5981C97G12	38DBU-175SE	5981C97G12	—	DBU	38	175SE
5981C97G13	38DBU-200SE	5981C97G13	—	DBU	38	200SE
5982C01G01	8CLS-2R	5982C01G01	—	CLS	8.3	2R(70)
5982C02G02	8CLS-3R	5982C02G02	—	CLS	8.3	3R(100)
5982C02G03	8CLS-4R	5982C02G03	—	CLS	8.3	4R(130)
5982C02G04	8CLS-5R	5982C02G04	—	CLS	8.3	5R(150)
5982C02G05	8CLS-6R	5982C02G05	—	CLS	8.3	6R(170)
5982C02G06	7CLS-9R	5982C02G06	—	CLS	7.2	9R(200)
5982C02G07	7CLS-12R	5982C02G07	—	CLS	7.2	12R(230)
5982C02G10	7CLS-18R	5982C02G10	—	CLS	7.2	18R(390)
5982C02G11	7CLS-24R	5982C02G11	—	CLS	7.2	24R(450)
5982C19G04	HCL-NL	5982C19G04	—	HCL	—	600
5982C29G01	HCL-NL	5982C19G04	—	HCL	—	600
5982C29G04	HCL-NL	5982C19G04	—	HCL	—	600
5982C31G01	5BCLS-30	5982C31G01	—	CLS	5.5	30
5982C31G02	5BCLS-2R	5982C31G02	—	CLS	5.5	2R(70)
5982C31G03	5BCLS-3R	5982C31G03	—	CLS	5.5	3R(100)
5982C31G04	5BCLS-4R	5982C31G04	—	CLS	5.5	4R(130)
5982C31G05	5BCLS-5R	5982C31G05	—	CLS	5.5	5R(150)
5982C31G06	5BCLS-6R	5982C31G06	—	CLS	5.5	6R(170)
5982C31G07	5BCLS-9R	5982C31G07	—	CLS	5.5	9R(200)
5982C31G08	5BCLS-12R	5982C31G08	—	CLS	5.5	12R(230)
5982C32G01	5BCLS-18R	5982C32G01	—	CLS	5.5	18R(390)

Appendix 2—Superseded Style Number Index

Old 10 Digit Style Number	Current Eaton Catalog Number	Eaton 10 Digit Style Number	Description	Type	Voltage Rating kV Max.	Current Rating Amperes
5982C32G02	5BCLS-24R	5982C32G02	—	CLS	5.5	24R(450)
5982C32G03	4BCLS-26R	5982C32G03	—	CLS	4.6	26R(480)
5982C34G01	15HCL-10E	5982C34G01	—	HCL	15.5	10E
5982C34G02	15HCL-15E	5982C34G02	—	HCL	15.5	15E
5982C34G03	15HCL-20E	5982C34G03	—	HCL	15.5	20E
5982C34G04	15HCL-25E	5982C34G04	—	HCL	15.5	25E
5982C34G05	15HCL-30E	5982C34G05	—	HCL	15.5	30E
5982C34G06	15HCL-40E	5982C34G06	—	HCL	15.5	40E
5982C34G07	15HCL-50E	5982C34G07	—	HCL	15.5	50E
5982C35G01	5HCL-10E	5982C35G01	—	HCL	5.5	10E
5982C35G02	5HCL-15E	5982C35G02	—	HCL	5.5	15E
5982C35G03	5HCL-20E	5982C35G03	—	HCL	5.5	20E
5982C35G04	5HCL-25E	5982C35G04	—	HCL	5.5	25E
5982C35G05	5HCL-30E	5982C35G05	—	HCL	5.5	30E
5982C35G06	5HCL-40E	5982C35G06	—	HCL	5.5	40E
5982C35G07	5HCL-50E	5982C35G07	—	HCL	5.5	50E
5982C35G08	5HCL-65E	5982C35G08	—	HCL	5.5	65E
5982C35G09	5HCL-80E	5982C35G09	—	HCL	5.5	80E
5982C35G10	5HCL-100E	5982C35G10	—	HCL	5.5	100E
5982C35G11	5HCL-125E	5982C35G11	—	HCL	5.5	125E
5982C35G12	5HCL-150E	5982C35G12	—	HCL	5.5	150E
5982C36G01	7BCLS-2R	5982C36G01	—	CLS	8.3	2R(70)
5982C36G02	7BCLS-3R	5982C36G02	—	CLS	8.3	3R(100)
5982C36G03	7BCLS-4R	5982C36G03	—	CLS	8.3	4R(130)
5982C36G04	7BCLS-5R	5982C36G04	—	CLS	8.3	5R(150)
5982C36G05	7BCLS-6R	5982C36G05	—	CLS	8.3	6R(170)
5982C36G06	7BCLS-9R	5982C36G06	—	CLS	7.2	9R(200)
5982C36G07	7BCLS-12R	5982C36G07	—	CLS	7.2	12R(230)
5982C36G08	7BCLS-18R	5982C36G08	—	CLS	7.2	18R(390)
5982C36G09	7BCLS-24R	5982C36G09	—	CLS	7.2	24R(450)
5982C44G01	8RBA4-.5E	5982C44G01	—	RBA4	8.3	0.5
5982C44G02	8RBA4-3E	5982C44G02	—	RBA4	8.3	3
5982C44G03	8RBA4-5E	5982C44G03	—	RBA4	8.3	5E
5982C44G04	8RBA4-7E	5982C44G04	—	RBA4	8.3	7E
5982C44G05	8RBA4-10E	5982C44G05	—	RBA4	8.3	10E
5982C44G06	8RBA4-15E	5982C44G06	—	RBA4	8.3	15E
5982C44G07	8RBA4-20E	5982C44G07	—	RBA4	8.3	20E
5982C44G08	8RBA4-25E	5982C44G08	—	RBA4	8.3	25E
5982C44G09	8RBA4-30E	5982C44G09	—	RBA4	8.3	30E
5982C44G10	8RBA4-40E	5982C44G10	—	RBA4	8.3	40E
5982C44G11	8RBA4-50E	5982C44G11	—	RBA4	8.3	50E
5982C44G12	8RBA4-65E	5982C44G12	—	RBA4	8.3	65E
5982C44G13	8RBA4-80E	5982C44G13	—	RBA4	8.3	80E
5982C44G14	8RBA4-100E	5982C44G14	—	RBA4	8.3	100E
5982C44G15	8RBA4-125E	5982C44G15	—	RBA4	8.3	125E
5982C44G16	8RBA4-150E	5982C44G16	—	RBA4	8.3	150E
5982C44G17	8RBA4-175E	5982C44G17	—	RBA4	8.3	175E
5982C44G18	8RBA4-200E	5982C44G18	—	RBA4	8.3	200E
5982C44G19	8RBA4-250E	5982C44G19	—	RBA4	8.3	250E
5982C44G20	8RBA4-300E	5982C44G20	—	RBA4	8.3	300E
5982C44G22	8RBA4-400E	5982C44G22	—	RBA4	8.3	400E
5982C44G26	15RBA4-.5E	5982C44G26	—	RBA4	15.5	0.5
5982C44G27	15RBA4-3E	5982C44G27	—	RBA4	15.5	3

Appendix 2—Superseded Style Number Index

Old 10 Digit Style Number	Current Eaton Catalog Number	Eaton 10 Digit Style Number	Description	Type	Voltage Rating kV Max.	Current Rating Amperes
5982C44G28	15RBA4-5E	5982C44G28	—	RBA4	15.5	5E
5982C44G29	15RBA4-7E	5982C44G29	—	RBA4	15.5	7E
5982C44G30	15RBA4-10E	5982C44G30	—	RBA4	15.5	10E
5982C44G31	15RBA4-15E	5982C44G31	—	RBA4	15.5	15E
5982C44G32	15RBA4-20E	5982C44G32	—	RBA4	15.5	20E
5982C44G33	15RBA4-25E	5982C44G33	—	RBA4	15.5	25E
5982C44G34	15RBA4-30E	5982C44G34	—	RBA4	15.5	30E
5982C44G35	15RBA4-40E	5982C44G35	—	RBA4	15.5	40E
5982C44G36	15RBA4-50E	5982C44G36	—	RBA4	15.5	50E
5982C44G37	15RBA4-65E	5982C44G37	—	RBA4	15.5	65E
5982C44G38	15RBA4-80E	5982C44G38	—	RBA4	15.5	80E
5982C44G39	15RBA4-100E	5982C44G39	—	RBA4	15.5	100E
5982C44G40	15RBA4-125E	5982C44G40	—	RBA4	15.5	125E
5982C44G41	15RBA4-150E	5982C44G41	—	RBA4	15.5	150E
5982C44G42	15RBA4-175E	5982C44G42	—	RBA4	15.5	175E
5982C44G43	15RBA4-200E	5982C44G43	—	RBA4	15.5	200E
5982C44G44	15RBA4-250E	5982C44G44	—	RBA4	15.5	250E
5982C44G45	15RBA4-300E	5982C44G45	—	RBA4	15.5	300E
5982C44G47	15RBA4-400E	5982C44G47	—	RBA4	15.5	400E
5982C44G51	25RBA4-.5E	5982C44G51	—	RBA4	25.5	0.5
5982C44G52	25RBA4-3E	5982C44G52	—	RBA4	25.5	3
5982C44G53	25RBA4-5E	5982C44G53	—	RBA4	25.5	5E
5982C44G54	25RBA4-7E	5982C44G54	—	RBA4	25.5	7E
5982C44G55	25RBA4-10E	5982C44G55	—	RBA4	25.5	10E
5982C44G56	25RBA4-15E	5982C44G56	—	RBA4	25.5	15E
5982C44G57	25RBA4-20E	5982C44G57	—	RBA4	25.5	20E
5982C44G58	25RBA4-25E	5982C44G58	—	RBA4	25.5	25E
5982C44G59	25RBA4-30E	5982C44G59	—	RBA4	25.5	30E
5982C44G60	25RBA4-40E	5982C44G60	—	RBA4	25.5	40E
5982C44G61	25RBA4-50E	5982C44G61	—	RBA4	25.5	50E
5982C44G62	25RBA4-65E	5982C44G62	—	RBA4	25.5	65E
5982C44G63	25RBA4-80E	5982C44G63	—	RBA4	25.5	80E
5982C44G64	25RBA4-100E	5982C44G64	—	RBA4	25.5	100E
5982C44G65	25RBA4-125E	5982C44G65	—	RBA4	25.5	125E
5982C44G66	25RBA4-150E	5982C44G66	—	RBA4	25.5	150E
5982C44G67	25RBA4-175E	5982C44G67	—	RBA4	25.5	175E
5982C44G68	25RBA4-200E	5982C44G68	—	RBA4	25.5	200E
5982C44G69	25RBA4-250E	5982C44G69	—	RBA4	25.5	250E
5982C44G70	25RBA4-300E	5982C44G70	—	RBA4	25.5	300E
5982C44G76	38RBA4-.5E	5982C44G76	—	RBA4	38	0.5
5982C44G77	38RBA4-3E	5982C44G77	—	RBA4	38	3
5982C44G78	38RBA4-5E	5982C44G78	—	RBA4	38	5E
5982C44G79	38RBA4-7E	5982C44G79	—	RBA4	38	7E
5982C44G80	38RBA4-10E	5982C44G80	—	RBA4	38	10E
5982C44G81	38RBA4-15E	5982C44G81	—	RBA4	38	15E
5982C44G82	38RBA4-20E	5982C44G82	—	RBA4	38	20E
5982C44G83	38RBA4-25E	5982C44G83	—	RBA4	38	25E
5982C44G84	38RBA4-30E	5982C44G84	—	RBA4	38	30E
5982C44G85	38RBA4-40E	5982C44G85	—	RBA4	38	40E
5982C44G86	38RBA4-50E	5982C44G86	—	RBA4	38	50E
5982C44G87	38RBA4-65E	5982C44G87	—	RBA4	38	65E
5982C44G88	38RBA4-80E	5982C44G88	—	RBA4	38	80E
5982C44G89	38RBA4-100E	5982C44G89	—	RBA4	38	100E

Appendix 2—Superseded Style Number Index

Old 10 Digit Style Number	Current Eaton Catalog Number	Eaton 10 Digit Style Number	Description	Type	Voltage Rating kV Max.	Current Rating Amperes
5982C44G90	38RBA4-125E	5982C44G90	—	RBA4	38	125E
5982C44G91	38RBA4-150E	5982C44G91	—	RBA4	38	150E
5982C44G92	38RBA4-175E	5982C44G92	—	RBA4	38	175E
5982C44G93	38RBA4-200E	5982C44G93	—	RBA4	38	200E
5982C44G94	38RBA4-250E	5982C44G94	—	RBA4	38	250E
5982C44G95	38RBA4-300E	5982C44G95	—	RBA4	38	300E
5982C47G01	2BCLS-25	5982C47G01	—	CLS	2.54	25
5982C47G02	2BCLS-2R	5982C47G02	—	CLS	2.54	2R(70)
5982C47G03	2BCLS-3R	5982C47G03	—	CLS	2.54	3R(100)
5982C47G04	2BCLS-4R	5982C47G04	—	CLS	2.54	4R(130)
5982C47G05	2BCLS-5R	5982C47G05	—	CLS	2.54	5R(150)
5982C47G06	2BCLS-6R	5982C47G06	—	CLS	2.54	6R(170)
5982C47G07	2BCLS-9R	5982C47G07	—	CLS	2.54	9R(200)
5982C47G08	2BCLS-12R	5982C47G08	—	CLS	2.54	12R(230)
5982C47G09	2BCLS-18R	5982C47G09	—	CLS	2.54	18R(390)
5982C47G10	2BCLS-24R	5982C47G10	—	CLS	2.54	24R(450)
5982C49A07	8RBT4-20E	5982C49A07	—	RBA4	8.3	20E
5982C49A08	8RBT4-25E	5982C49A08	—	RBA4	8.3	25E
5982C49A09	8RBT4-30E	5982C49A09	—	RBA4	8.3	30E
5982C49A10	8RBT4-40E	5982C49A10	—	RBA4	8.3	40E
5982C49A11	8RBT4-50E	5982C49A11	—	RBA4	8.3	50E
5982C49A12	8RBT4-65E	5982C49A12	—	RBA4	8.3	65E
5982C49A13	8RBT4-80E	5982C49A13	—	RBA4	8.3	80E
5982C49A14	8RBT4-100E	5982C49A14	—	RBA4	8.3	100E
5982C49A15	8RBT4-125E	5982C49A15	—	RBA4	8.3	125E
5982C49A16	8RBT4-150E	5982C49A16	—	RBA4	8.3	150E
5982C49A18	8RBT4-200E	5982C49A18	—	RBA4	8.3	200E
5982C49A19	8RBT4-250E	5982C49A19	—	RBA4	8.3	250E
5982C49A20	8RBT4-300E	5982C49A20	—	RBA4	8.3	300E
5982C49A21	8RBT4-400E	5982C49A21	—	RBA4	8.3	400E
5982C49A32	15RBT4-20E	5982C49A32	—	RBA4	15.5	20E
5982C49A33	15RBT4-25E	5982C49A33	—	RBA4	15.5	25E
5982C49A34	15RBT4-30E	5982C49A34	—	RBA4	15.5	30E
5982C49A35	15RBT4-40E	5982C49A35	—	RBA4	15.5	40E
5982C49A36	15RBT4-50E	5982C49A36	—	RBA4	15.5	50E
5982C49A37	15RBT4-65E	5982C49A37	—	RBA4	15.5	65E
5982C49A38	15RBT4-80E	5982C49A38	—	RBA4	15.5	80E
5982C49A39	15RBT4-100E	5982C49A39	—	RBA4	15.5	100E
5982C49A40	15RBT4-125E	5982C49A40	—	RBA4	15.5	125E
5982C49A41	15RBT4-150E	5982C49A41	—	RBA4	15.5	150E
5982C49A43	15RBT4-200E	5982C49A43	—	RBA4	15.5	200E
5982C49A44	15RBT4-250E	5982C49A44	—	RBA4	15.5	250E
5982C49A45	15RBT4-300E	5982C49A45	—	RBA4	15.5	300E
5982C49A46	15RBT4-400E	5982C49A46	—	RBA4	15.5	400E
5982C49A57	25RBT4-20E	5982C49A57	—	RBA4	25.5	20E
5982C49A58	25RBT4-25E	5982C49A58	—	RBA4	25.5	25E
5982C49A59	25RBT4-30E	5982C49A59	—	RBA4	25.5	30E
5982C49A60	25RBT4-40E	5982C49A60	—	RBA4	25.5	40E
5982C49A61	25RBT4-50E	5982C49A61	—	RBA4	25.5	50E
5982C49A62	25RBT4-65E	5982C49A62	—	RBA4	25.5	65E
5982C49A63	25RBT4-80E	5982C49A63	—	RBA4	25.5	80E
5982C49A64	25RBT4-100E	5982C49A64	—	RBA4	25.5	100E
5982C49A65	25RBT4-125E	5982C49A65	—	RBA4	25.5	125E

Appendix 2—Superseded Style Number Index

Old 10 Digit Style Number	Current Eaton Catalog Number	Eaton 10 Digit Style Number	Description	Type	Voltage Rating kV Max.	Current Rating Amperes
5982C49A66	25RBT4-150E	5982C49A66	—	RBA4	25.5	150E
5982C49A68	25RBT4-200E	5982C49A68	—	RBA4	25.5	200E
5982C49A69	25RBT4-250E	5982C49A69	—	RBA4	25.5	250E
5982C49A70	25RBT4-300E	5982C49A70	—	RBA4	25.5	300E
5982C49A82	38RBT4-20E	5982C49A82	—	RBA4	38	20E
5982C49A83	38RBT4-25E	5982C49A83	—	RBA4	38	25E
5982C49A84	38RBT4-30E	5982C49A84	—	RBA4	38	30E
5982C49A85	38RBT4-40E	5982C49A85	—	RBA4	38	40E
5982C49A86	38RBT4-50E	5982C49A86	—	RBA4	38	50E
5982C49A87	38RBT4-65E	5982C49A87	—	RBA4	38	65E
5982C49A88	38RBT4-80E	5982C49A88	—	RBA4	38	80E
5982C49A89	38RBT4-100E	5982C49A89	—	RBA4	38	100E
5982C49A90	38RBT4-125E	5982C49A90	—	RBA4	38	125E
5982C49A91	38RBT4-150E	5982C49A91	—	RBA4	38	150E
5982C49A93	38RBT4-200E	5982C49A93	—	RBA4	38	200E
5982C49A94	38RBT4-250E	5982C49A94	—	RBA4	38	250E
5982C49A95	38RBT4-300E	5982C49A95	—	RBA4	38	300E
5982C64G01	4NPL-3500	5982C64G01	—	NPL	0.48	3500
5982C64G02	4NPL-5000	5982C64G02	—	NPL	0.48	5000
5982C90G01	6MDSL-A150	5982C90G01	—	DSL	0.6	150
5982C90G02	6MDSL-A200	5982C90G02	—	DSL	0.6	200
5982C90G03	6MDSL-A250	5982C90G03	—	DSL	0.6	250
5982C90G04	6MDSL-A300	5982C90G04	—	DSL	0.6	300
5982C90G05	6MDSL-A400	5982C90G05	—	DSL	0.6	400
5982C90G06	6MDSL-A600	5982C90G06	—	DSL	0.6	600
5982C90G07	6MDSL-A800	5982C90G07	—	DSL	0.6	800
5982C91G01	6MDSL-B1200	5982C91G01	—	DSL	0.6	1200
5982C91G02	6MDSL-B1600	5982C91G02	—	DSL	0.6	1600
5982C91G03	6MDSL-B2000	5982C91G03	—	DSL	0.6	2000
5982C92G01	6MDSL-C800	5982C92G01	—	DSL	0.6	800
5982C92G02	6MDSL-C1000	5982C92G02	—	DSL	0.6	1000
5982C92G03	6MDSL-C1200	5982C92G03	—	DSL	0.6	1200
5982C92G04	6MDSL-C1600	5982C92G04	—	DSL	0.6	1600
5982C92G05	6MDSL-C2000	5982C92G05	—	DSL	0.6	2000
5982C93G01	6MDSL-D2500	5982C93G01	—	DSL	0.6	2500
5982C93G02	6MDSL-D3000	5982C93G02	—	DSL	0.6	3000
5983C02G01	5BHLE-10E	5983C02G01	—	HLE	5.5	10E
5983C02G02	5BHLE-15E	5983C02G02	—	HLE	5.5	15E
5983C02G03	5BHLE-20E	5983C02G03	—	HLE	5.5	20E
5983C02G04	5BHLE-25E	5983C02G04	—	HLE	5.5	25E
5983C02G05	5BHLE-30E	5983C02G05	—	HLE	5.5	30E
5983C02G06	5BHLE-40E	5983C02G06	—	HLE	5.5	40E
5983C02G07	5BHLE-50E	5983C02G07	—	HLE	5.5	50E
5983C02G08	5BHLE-65E	5983C02G08	—	HLE	5.5	65E
5983C02G09	5BHLE-80E	5983C02G09	—	HLE	5.5	80E
5983C02G10	5BHLE-100E	5983C02G10	—	HLE	5.5	100E
5983C02G11	5BHLE-125E	5983C02G11	—	HLE	5.5	125E
5983C02G12	5BHLE-150E	5983C02G12	—	HLE	5.5	150E
5983C02G13	5BHLE-175E	5983C02G13	—	HLE	5.5	175E
5983C02G14	5BHLE-200E	5983C02G14	—	HLE	5.5	200E
5983C02G15	5BHLE-250E	5983C02G15	—	HLE	5.5	250E
5983C02G16	5BHLE-300E	5983C02G16	—	HLE	5.5	300E
5983C02G17	5BHLE-350E	5983C02G17	—	HLE	5.5	350E

Appendix 2—Superseded Style Number Index

Old 10 Digit Style Number	Current Eaton Catalog Number	Eaton 10 Digit Style Number	Description	Type	Voltage Rating kV Max.	Current Rating Amperes
5983C02G18	5BHLE-400E	5983C02G18	—	HLE	5.5	400E
5983C02G19	5BHLE-450E	5983C02G19	—	HLE	5.5	450E
5983C03G01	8BHLE-10E	5983C03G01	—	HLE	8.3	10E
5983C03G02	8BHLE-15E	5983C03G02	—	HLE	8.3	15E
5983C03G03	8BHLE-20E	5983C03G03	—	HLE	8.3	20E
5983C03G04	8BHLE-25E	5983C03G04	—	HLE	8.3	25E
5983C03G05	8BHLE-30E	5983C03G05	—	HLE	8.3	30E
5983C03G06	8BHLE-40E	5983C03G06	—	HLE	8.3	40E
5983C03G07	8BHLE-50E	5983C03G07	—	HLE	8.3	50E
5983C03G08	8BHLE-65E	5983C03G08	—	HLE	8.3	65E
5983C03G09	8BHLE-80E	5983C03G09	—	HLE	8.3	80E
5983C03G10	8BHLE-100E	5983C03G10	—	HLE	8.3	100E
5983C03G11	8BHLE-125E	5983C03G11	—	HLE	8.3	125E
5983C03G12	8BHLE-150E	5983C03G12	—	HLE	8.3	150E
5983C03G13	8BHLE-175E	5983C03G13	—	HLE	8.3	175E
5983C03G14	8BHLE-200E	5983C03G14	—	HLE	8.3	200E
5983C03G15	8BHLE-250E	5983C03G15	—	HLE	8.3	250E
5983C03G16	8BHLE-300E	5983C03G16	—	HLE	8.3	300E
5983C03G17	8BHLE-350E	5983C03G17	—	HLE	8.3	350E
5983C08G01	8HCL-200E	5983C08G01	—	HCL	8.3	200E
5983C08G02	8HCL-250E	5983C08G02	—	HCL	8.3	250E
5983C08G03	8HCL-300E	5983C08G03	—	HCL	8.3	300E
5983C08G04	8HCL-350E	5983C08G04	—	HCL	8.3	350E
5983C08G05	8HCL-175E	5983C08G05	—	HCL	8.3	175E
5983C08G06	8HCL-150E	5983C08G06	—	HCL	8.3	150E
5983C08G07	8HCL125E	5983C08G07	—	HCL	8.3	125E
5983C08G08	8HCL-100E	5983C08G08	—	HCL	8.3	100E
5983C08G09	8HCL-80E	5983C08G09	—	HCL	8.3	80E
5983C08G10	8HCL-65E	5983C08G10	—	HCL	8.3	65E
5984C05G01	15BHLE-10E	5984C05G01	—	HLE	15.5	10E
5984C05G02	15BHLE-15E	5984C05G02	—	HLE	15.5	15E
5984C05G03	15BHLE-20E	5984C05G03	—	HLE	15.5	20E
5984C05G04	15BHLE-25E	5984C05G04	—	HLE	15.5	25E
5984C05G05	15BHLE-30E	5984C05G05	—	HLE	15.5	30E
5984C05G06	15BHLE-40E	5984C05G06	—	HLE	15.5	40E
5984C05G07	15BHLE-50E	5984C05G07	—	HLE	15.5	50E
5984C05G08	15BHLE-65E	5984C05G08	—	HLE	15.5	65E
5984C05G09	15BHLE-80E	5984C05G09	—	HLE	15.5	80E
5984C05G10	15BHLE-100E	5984C05G10	—	HLE	15.5	100E
5984C05G11	15BHLE-125E	5984C05G11	—	HLE	15.5	125E
5984C05G12	15BHLE-150E	5984C05G12	—	HLE	15.5	150E
5984C05G13	15BHLE-175E	5984C05G13	—	HLE	15.5	175E
5984C05G14	15BHLE-200E	5984C05G14	—	HLE	15.5	200E
5984C05G15	15BHLE-250E	5984C05G15	—	HLE	15.5	250E
5984C05G16	15BHLE2-40E	5984C05G16	—	HLE	15.5	40E
5984C05G17	15BHLE2-50E	5984C05G17	—	HLE	15.5	50E
5984C05G18	15BHLE2-65E	5984C05G18	—	HLE	15.5	65E
5984C05G19	15BHLE2-80E	5984C05G19	—	HLE	15.5	80E
5984C05G20	15BHLE2-100E	5984C05G20	—	HLE	15.5	100E
5984C05G21	15BHLE2-125E	5984C05G21	—	HLE	15.5	125E
5984C17G01	8RBA4-INH-B	5984C17G01	—	RBA4	8.3	400
5984C17G02	15RBA4-INH-B	5984C17G02	—	RBA4	15.5	400
5984C17G03	25RBA4-INH-B	5984C17G03	—	RBA4	25.5	300

Appendix 2—Superseded Style Number Index

Old 10 Digit Style Number	Current Eaton Catalog Number	Eaton 10 Digit Style Number	Description	Type	Voltage Rating kV Max.	Current Rating Amperes
5984C17G04	38RBA4-INH-B	5984C17G04	—	RBA4	38	300
5094C18G01	8RBA2-INH-B	5094C18G01	—	RBA2	8.3	200
5094C18G02	15RBA2-INH-B	5094C18G02	—	RBA2	15.5	200
5094C18G03	25RBA2-INH-B	5094C18G03	—	RBA2	25.5	200
5094C18G04	38RBA2-INH-B	5094C18G04	—	RBA2	38	200
5984C25G01	DBU17-GNMP-L	5984C25G01	—	DBU	17	200
5984C25G02	DBU27-GNMP-L	5984C25G02	—	DBU	27	200
5984C25G03	DBU38-GNMP-L	5984C25G03	—	DBU	38	200
5984C25G04	DBU17-GNMP-R	5984C25G04	—	DBU	17	200
5984C25G05	DBU27-GNMP-R	5984C25G05	—	DBU	27	200
5984C25G06	DBU38-GNMP-R	5984C25G06	—	DBU	38	200
5984C25G07	DBU17-GNM-L	5984C25G07	—	DBU	17	200
5984C25G08	DBU27-GNM-L	5984C25G08	—	DBU	27	200
5984C25G09	DBU38-GNM-L	5984C25G09	—	DBU	38	200
5984C25G10	DBU17-GNM-R	5984C25G10	—	DBU	17	200
5984C25G11	DBU27-GNM-R	5984C25G11	—	DBU	27	200
5984C25G12	DBU38-GNM-R	5984C25G12	—	DBU	38	200
5984C29G01	DBU17-NL-L	5984C29G01	—	DBU	17	200
5984C29G02	DBU27-NL-L	5984C29G02	—	DBU	27	200
5984C29G03	DBU38-NL-L	5984C29G03	—	DBU	38	200
5984C29G04	DBU17-NL-R	5984C29G04	—	DBU	17	200
5984C29G05	DBU27-NL-R	5984C29G05	—	DBU	27	200
5984C29G06	DBU38-NL-R	5984C29G06	—	DBU	38	200
5984C29G07	DBU17-NLP-L	5984C29G07	—	DBU	17	200
5984C29G08	DBU27-NLP-L	5984C29G08	—	DBU	27	200
5984C29G09	DBU38-NLP-L	5984C29G09	—	DBU	38	200
5984C29G10	DBU17-NLP-R	5984C29G10	—	DBU	17	200
5984C29G11	DBU27-NLP-R	5984C29G11	—	DBU	27	200
5984C29G12	DBU38-NLP-R	5984C29G12	—	DBU	38	200
5984C38G01	DBU27-DM	5984C38G01	—	DBU	17	200
5984C39G01	DBU17-DM	5984C39G01	—	DBU	27	200
5984C50G01	5HME-40E	5984C50G01	—	HME	5.5	40E
5984C50G02	5HME-125E	5984C50G02	—	HME	5.5	125E
5984C50G04	5CME-40E	5984C50G04	—	CME	5.5	40E
5984C50G05	5CME-125E	5984C50G05	—	CME	5.5	125E
5984C50G06	5CME-200E	5984C50G06	—	CME	5.5	200E
5984C50G21	5BHME-40E	5984C50G21	—	HME	5.5	40E
5984C50G22	5BHME-125E	5984C50G22	—	HME	5.5	125E
5984C50G24	5BCME-40E	5984C50G24	—	CME	5.5	40E
5984C50G25	5BCME-125E	5984C50G25	—	CME	5.5	125E
5984C50G26	5BCME-200E	5984C50G26	—	CME	5.5	200E
5984C56G01	5MCLS-30-A	5984C56G01	—	CLS	5.08	30
5984C56G02	5MCLS-2R-A	5984C56G02	—	CLS	5.08	2R(70)
5984C56G03	5MCLS-3R-A	5984C56G03	—	CLS	5.08	3R(100)
5984C56G04	5MCLS-4R-A	5984C56G04	—	CLS	5.08	4R(130)
5984C56G05	5MCLS-5R-A	5984C56G05	—	CLS	5.08	5R(150)
5984C56G06	5MCLS-5R-A	5984C56G06	—	CLS	5.08	6R(170)
5984C56G09	5MCLS-8R-A	5984C56G09	—	CLS	5.08	9R(200)
5984C56G12	5MCLS-12R-A	5984C56G12	—	CLS	5.08	12R(230)
5984C56G18	5MCLS-18R-A	5984C56G18	—	CLS	5.08	18R(390)
5984C56G24	5MCLS-24R-A	5984C56G24	—	CLS	5.08	24R(450)
5984C56G36	5MCLS-36R-A	5984C56G36	—	CLS	5.08	36R(650)
5984 C57G01	5MCLS-30-B	5984 C57G01	—	CLS	5.08	30

Appendix 2—Superseded Style Number Index

Old 10 Digit Style Number	Current Eaton Catalog Number	Eaton 10 Digit Style Number	Description	Type	Voltage Rating kV Max.	Current Rating Amperes
5984 C57G02	5MCLS-2R-B	5984 C57G02	—	CLS	5.08	2R(70)
5984 C57G03	5MCLS-3R-B	5984 C57G03	—	CLS	5.08	3R(100)
5984 C57G04	5MCLS-4R-B	5984 C57G04	—	CLS	5.08	4R(130)
5984 C57G05	5MCLS-5R-B	5984 C57G05	—	CLS	5.08	5R(150)
5984 C57G06	5MCLS-5R-B	5984 C57G06	—	CLS	5.08	6R(170)
5984 C57G09	5MCLS-8R-B	5984 C57G09	—	CLS	5.08	9R(200)
5984 C57G12	5MCLS-12R-B	5984 C57G12	—	CLS	5.08	12R(230)
5984 C57G18	5MCLS-18R-B	5984 C57G18	—	CLS	5.08	18R(390)
5984 C57G24	5MCLS-24R-B	5984 C57G24	—	CLS	5.08	24R(450)
5984 C57G36	5MCLS-36R-B	5984 C57G36	—	CLS	5.08	36R(650)
5984C65G01	15LHLE-65E	5984C65G01	—	HLE	15.5	65E
5984C65G02	15LHLE-80E	5984C65G02	—	HLE	15.5	80E
5984C65G03	15LHLE-100E	5984C65G03	—	HLE	15.5	100E
5984C65G04	15LHLE2-125E	5984C65G04	—	HLE	15.5	125E
5984C65G05	15LHLE2-150E	5984C65G05	—	HLE	15.5	150E
5984C65G06	15LHLE-175E	5984C65G06	—	HLE	15.5	175E
5984C65G07	15LHLE-200E	5984C65G07	—	HLE	15.5	200E
5984C65G08	15LHLE-125E	5984C65G08	—	HLE	15.5	125E
5984C65G09	15LHLE-150E	5984C65G09	—	HLE	15.5	150E
5984C65G10	15LHLE-250E	5984C65G10	—	HLE	15.5	250E
5984C65G11	15LHLE-300E	5984C65G11	—	HLE	15.5	300E
60A1307G01	Obsolete—contact Eaton	—	4.8 kV RBA-800 mounting	—	—	—
60A1307G02	Obsolete—contact Eaton	—	7.2 kV RBA-800 mounting	—	—	—
60A1307G03	Obsolete—contact Eaton	—	13.2 kV RBA-800 mounting	—	—	—
60A1307G04	Obsolete—contact Eaton	—	14.4 kV RBA-800 mounting	—	—	—
6379D26H01	Obsolete—contact Eaton	—	5ACLS-.5R (10A)	—	—	—
6379D26H02	Obsolete—contact Eaton	—	5ACLS-.75R (20A)	—	—	—
6379D26H03	5ACLS-30	449D597G01	—	CLS	5.08	30
6379D26H04	Obsolete—contact Eaton	—	5ACLS-1.5R (40A)	CLS	5.08	2R(70)
6379D26H05	5ACLS-2R (70A)	449D597G02	—	CLS	5.08	3R(100)
6379D26H06	5ACLS-3R (100A)	449D597G03	—	CLS	5.08	4R(130)
6379D26H07	5ACLS-4R (130A)	449D597G04	—	CLS	5.08	5R(150)
6379D26H08	5ACLS-5R (150A)	449D597G05	—	CLS	5.08	6R(170)
6379D26H09	5ACLS-6R (170A)	449D597G06	—	CLS	5.08	9R(200)
6379D26H12	5ACLS-9R (200A)	151D933G01	—	CLS	5.08	12R(230)
6379D26H15	5ACLS-12R (230A)	151D933G02	—	CLS	5.08	18R(390)
6369D26H20	5ACLS-19R (390A)	151D933G03	—	CLS	5.08	24R(450)
6379D28H24	5ACLS-24R (450A)	151D933G04	—	—	—	—
6379D26H26	Obsolete—contact Eaton	—	—	—	—	—
6379D26H28	Obsolete—contact Eaton	—	—	—	—	—
6379D26H30	Obsolete—contact Eaton	—	—	—	—	—
676C231A10	Obsolete—contact Eaton	—	2.4 kV rear connected disc. CLE mounting	—	—	—
676C231A11	Obsolete—contact Eaton	—	4.8 kV rear connected disc. CLE mounting	—	—	—
676C231A13	Obsolete—contact Eaton	—	7.2 kV rear connected disc. CLE mounting	—	—	—
676C231A15	Obsolete—contact Eaton	—	13.8 kV rear connected disc. CLE mounting	—	—	—
676C231A16	Obsolete—contact Eaton	—	14.4 kV rear connected disc. CLE mounting	—	—	—
676C231A18	Obsolete—contact Eaton	—	2.4 kV rear connected disc. CLE mounting	—	—	—
676C231A19	Obsolete—contact Eaton	—	4.8 kV rear connected disc. CLE mounting	—	—	—
676C231A21	Obsolete—contact Eaton	—	7.2 kV rear connected disc. CLE mounting	—	—	—
676C231A23	Obsolete—contact Eaton	—	13.8 kV rear connected disc. CLE mounting	—	—	—
676C231A24	Obsolete—contact Eaton	—	14.4 kV rear connected disc. CLE mounting	—	—	—
676C231A26	Obsolete—contact Eaton	—	2.4 kV rear connected disc. CLE mounting	—	—	—
676C231A27	Obsolete—contact Eaton	—	4.8 kV rear connected disc. CLE mounting	—	—	—

Appendix 2—Superseded Style Number Index

Old 10 Digit Style Number	Current Eaton Catalog Number	Eaton 10 Digit Style Number	Description	Type	Voltage Rating kV Max.	Current Rating Amperes
676C231A29	Obsolete—contact Eaton	—	7.2 kV rear connected disc. CLE mounting	—	—	—
676C231A31	Obsolete—contact Eaton	—	13.8 kV rear connected disc. CLE mounting	—	—	—
676C231A32	Obsolete—contact Eaton	—	14.4 kV rear connected disc. CLE mounting	—	—	—
676C232G07	CLPT-DL	9078A64G01	—	CLPT	—	10
676C233A09	Obsolete—contact Eaton	—	4.8 kV rear connected disc. CLPT mounting	—	—	—
676C233A10	Obsolete—contact Eaton	—	7.2 kV rear connected disc. CLPT mounting	—	—	—
676C233A12	Obsolete—contact Eaton	—	13.8 kV rear connected disc. CLPT mounting	—	—	—
676C233A13	Obsolete—contact Eaton	—	14.4 kV rear connected disc. CLPT mounting	—	—	—
676C233A14	Obsolete—contact Eaton	—	23 kV rear connected disc. CLPT mounting	—	—	—
676C233A17	Obsolete—contact Eaton	—	4.8 kV rear connected disc. CLPT mounting	—	—	—
676C233A18	Obsolete—contact Eaton	—	7.2 kV rear connected disc. CLPT mounting	—	—	—
676C233A20	Obsolete—contact Eaton	—	13.8 kV rear connected disc. CLPT mounting	—	—	—
676C233A21	Obsolete—contact Eaton	—	14.4 kV rear connected disc. CLPT mounting	—	—	—
676C233A22	Obsolete—contact Eaton	—	23 kV rear connected disc. CLPT mounting	—	—	—
676C233A25	Obsolete—contact Eaton	—	4.8 kV rear connected disc. CLPT mounting	—	—	—
676C233A26	Obsolete—contact Eaton	—	7.2 kV rear connected disc. CLPT mounting	—	—	—
676C233A28	Obsolete—contact Eaton	—	13.8 kV rear connected disc. CLPT mounting	—	—	—
676C233A29	Obsolete—contact Eaton	—	14.4 kV rear connected disc. CLPT mounting	—	—	—
676C233A30	Obsolete—contact Eaton	—	23 kV rear connected disc. CLPT mounting	—	—	—
676C234A09	Obsolete—contact Eaton	—	7.2 kV rear connected disc. CLPT mounting	—	—	—
676C234A11	Obsolete—contact Eaton	—	13.8 kV rear connected disc. CLPT mounting	—	—	—
676C234A12	Obsolete—contact Eaton	—	14.4 kV rear connected disc. CLPT mounting	—	—	—
676C234A17	Obsolete—contact Eaton	—	7.2 kV rear connected disc. CLPT mounting	—	—	—
676C234A19	Obsolete—contact Eaton	—	13.8 kV rear connected disc. CLPT mounting	—	—	—
676C234A20	Obsolete—contact Eaton	—	14.4 kV rear connected disc. CLPT mounting	—	—	—
676C234A26	Obsolete—contact Eaton	—	7.2 kV rear connected disc. CLPT mounting	—	—	—
676C234A28	Obsolete—contact Eaton	—	13.8 kV rear connected disc. CLPT mounting	—	—	—
676C234A29	Obsolete—contact Eaton	—	14.4 kV rear connected disc. CLPT mounting	—	—	—
676C236A11	Obsolete—contact Eaton	—	4.8 kV rear connected disc. CLPT mounting	—	—	—
676C236A12	Obsolete—contact Eaton	—	7.2 kV rear connected disc. CLPT mounting	—	—	—
676C236A14	Obsolete—contact Eaton	—	13.8 kV rear connected disc. CLPT mounting	—	—	—
676C236A15	Obsolete—contact Eaton	—	14.4 kV rear connected disc. CLPT mounting	—	—	—
676C236A16	Obsolete—contact Eaton	—	23 kV rear connected disc. CLPT mounting	—	—	—
676C236A21	Obsolete—contact Eaton	—	4.8 kV rear connected disc. CLPT mounting	—	—	—
676C236A22	Obsolete—contact Eaton	—	7.2 kV rear connected disc. CLPT mounting	—	—	—
676C236A24	Obsolete—contact Eaton	—	13.8 kV rear connected disc. CLPT mounting	—	—	—
676C236A25	Obsolete—contact Eaton	—	14.4 kV rear connected disc. CLPT mounting	—	—	—
676C236A26	Obsolete—contact Eaton	—	23 kV rear connected disc. CLPT mounting	—	—	—
676C237A11	Obsolete—contact Eaton	—	7.2 kV rear connected disc. CLPT mounting	—	—	—
676C237A13	Obsolete—contact Eaton	—	13.8 kV rear connected disc. CLPT mounting	—	—	—
676C237A14	Obsolete—contact Eaton	—	14.4 kV rear connected disc. CLPT mounting	—	—	—
676C237A21	Obsolete—contact Eaton	—	7.2 kV rear connected disc. CLPT mounting	—	—	—
676C237A23	Obsolete—contact Eaton	—	13.8 kV rear connected disc. CLPT mounting	—	—	—
676C237A24	Obsolete—contact Eaton	—	14.4 kV rear connected disc. CLPT mounting	—	—	—
676C238A12	Obsolete—contact Eaton	—	2.4 kV rear connected disc. CLE-C mounting	—	—	—
676C238A13	Obsolete—contact Eaton	—	4.8 kV rear connected disc. CLE-C mounting	—	—	—
676C238A15	Obsolete—contact Eaton	—	7.2 kV rear connected disc. CLE-C mounting	—	—	—
676C238A17	Obsolete—contact Eaton	—	13.8 kV rear connected disc. CLE-C mounting	—	—	—
676C238A18	Obsolete—contact Eaton	—	14.4 kV rear connected disc. CLE-C mounting	—	—	—
676C238A22	Obsolete—contact Eaton	—	2.4 kV rear connected disc. CLE-C mounting	—	—	—
676C238A23	Obsolete—contact Eaton	—	4.8 kV rear connected disc. CLE-C mounting	—	—	—
676C238A25	Obsolete—contact Eaton	—	7.2 kV rear connected disc. CLE-C mounting	—	—	—
676C238A27	Obsolete—contact Eaton	—	13.8 kV rear connected disc. CLE-C mounting	—	—	—

Appendix 2—Superseded Style Number Index

Old 10 Digit Style Number	Current Eaton Catalog Number	Eaton 10 Digit Style Number	Description	Type	Voltage Rating kV Max.	Current Rating Amperes
676C238A28	Obsolete—contact Eaton	—	14.4 kV rear connected disc. CLE-C mounting	—	—	—
676C436G14	5CLE-40E	5981C65G01	—	CLE	5.5	40E
676C546G02	2CLS-2R	591C812G02	—	CLS	2.54	2R(70)
676C546G03	2CLS-3R	591C812G03	—	CLS	2.54	3R(100)
676C546G04	2CLS-4R	591C812G04	—	CLS	2.54	4R(130)
676C546G05	2CLS-5R	591C812G05	—	CLS	2.54	5R(150)
676C546G06	2CLS-6R	591C812G06	—	CLS	2.54	6R(170)
676C546G09	2CLS-9R	591C812G07	—	CLS	2.54	9R(200)
676C546G12	2CLS-12R	591C812G08	—	CLS	2.54	12R(230)
676C546G14	5CLE-40E	5981C65G01	—	CLE	5.5	40E
676C546G15	5LCLS-2R	676C546G15	—	CLS	2.54	2R(70)
676C546G16	5LCLS-3R	676C546G16	—	CLS	2.54	3R(100)
676C546G17	5LCLS-4R	676C546G17	—	CLS	2.54	4R(130)
676C546G18	5LCLS-5R	676C546G18	—	CLS	2.54	5R(150)
676C546G19	5LCLS-6R	676C546G19	—	CLS	2.54	6R(170)
676C546G22	5LCLS-9R	676C546G22	—	CLS	2.54	9R(200)
676C546G25	5LCLS-12R	676C546G25	—	CLS	2.54	12R(230)
676C774G10	Obsolete—contact Eaton	—	CLE rear connected live parts	—	—	—
676C774G11	Obsolete—contact Eaton	—	CLE rear connected live parts	—	—	—
676C774G14	Obsolete—contact Eaton	—	CLE rear connected live parts	—	—	—
676C776A02	2CLE-PNM-D	9078A68G15	—	CLE	2.75	250
676C776A03	5CLE-PNM-D	9078A68G16	—	CLE	5.5	250
676C776A05	8CLE-PNM-D	9078A68G17	—	CLE	8.3	175
676C776A07	15CLE-PNM-D	9078A68G18	—	CLE	15.5	150
676C776A11	Obsolete—contact Eaton	—	2.4 kV rear connected CLE-D mounting	—	—	—
676C776A12	Obsolete—contact Eaton	—	4.8 kV rear connected CLE-D mounting	—	—	—
676C776A14	Obsolete—contact Eaton	—	7.2 kV rear connected CLE-D mounting	—	—	—
676C776A16	Obsolete—contact Eaton	—	14.4 kV rear connected CLE-D mounting	—	—	—
676C776A20	Obsolete—contact Eaton	—	2.4 kV rear connected CLE-D mounting	—	—	—
676C776A21	Obsolete—contact Eaton	—	4.8 kV rear connected CLE-D mounting	—	—	—
676C776A23	Obsolete—contact Eaton	—	7.2 kV rear connected CLE-D mounting	—	—	—
676C776A25	Obsolete—contact Eaton	—	14.4 kV rear connected CLE-D mounting	—	—	—
676C880G01	8RBA2-NH	5981C51G01	—	RBA2	8.3	200
676C880G02	15RBA2-NH	5981C51G02	—	RBA2	15.5	200
676C880G03	25RBA2-NH	5981C51G03	—	RBA2	25.5	200
676C880G04	38RBA2-NH	5981C51G04	—	RBA2	38	200
677C370G01	8RBA2-NH	5981C51G01	—	RBA2	8.3	200
677C370G02	15RBA2-NH	5981C51G02	—	RBA2	15.5	200
677C370G03	25RBA2-NH	5981C51G03	—	RBA2	25.5	200
677C370G04	38RBA2-NH	5981C51G04	—	RBA2	38	200
677C371G01	8RBA4-NH	5981C53G01	—	RBA4	8.3	400
677C371G02	15RBA4-NH	5981C53G02	—	RBA4	15.5	400
677C371G03	25RBA4-NH	5981C53G03	—	RBA4	25.5	300
677C371G04	38RBA4-NH	5981C53G04	—	RBA4	38	300
677C452G01	5CLPT-.5E	677C452G01	—	CLPT	5.5	0.5
677C452G02	8CLPT-.5E	677C452G02	—	CLPT	8.3	0.5
677C452G03	15CLPT-.5E	677C452G03	—	CLPT	15.5	0.5
677C452G04	25CLPT-.5E	677C452G04	—	CLPT	25.5	0.5
677C452G05	38CLPT-.5E	677C452G05	—	CLPT	38	0.5
677C452G06	5CLPT-1E	677C452G06	—	CLPT	5.5	1
677C452G08	15CLPT-1E	677C452G08	—	CLPT	15.5	1
677C452G09	25CLPT-1E	677C452G09	—	CLPT	25.5	1
677C452G10	15CLPT-1.5E	677C452G10	—	CLPT	15.5	1.5

Appendix 2—Superseded Style Number Index

Old 10 Digit Style Number	Current Eaton Catalog Number	Eaton 10 Digit Style Number	Description	Type	Voltage Rating kV Max.	Current Rating Amperes
677C452G11	5CLPT-1.5E	677C452G11	—	CLPT	5.5	1.5
677C453G01	5CLPT-5E	677C453G01	—	CLPT	5.5	5E
677C453G02	8CLPT-5E	677C453G02	—	CLPT	8.3	5E
677C453G03	15CLPT-5E	677C453G03	—	CLPT	15.5	5E
677C453G04	5CLPT-10E	677C453G04	—	CLPT	5.5	10E
677C453G05	8CLPT-10E	677C453G05	—	CLPT	8.3	10E
677C453G06	15CLPT-10E	677C453G06	—	CLPT	15.5	10E
677C453G07	5CLPT-3E	677C453G07	—	CLPT	5.5	3E
677C453G08	8CLPT-3E	677C453G08	—	CLPT	8.3	3E
677C453G09	15CLPT-3E	677C453G09	—	CLPT	15.5	3E
677C573G01	8CLE-30E	5981C31G05	—	CLE	8.3	30E
677C573G02	8CLE-40E	5981C17G04	—	CLE	8.3	40E
677C573G03	8CLE-50E	5981C17G05	—	CLE	8.3	50E
677C573G04	8CLE-65E	5981C17G06	—	CLE	8.3	65E
677C573G05	8CLE-80E	5981C17G07	—	CLE	8.3	80E
677C573G06	8CLE-100E	5981C17G08	—	CLE	8.3	100E
677C573G07	8CLE-125E	5981C17G09	—	CLE	8.3	125E
677C574G01	8CLE-150E	5981C17G10	—	CLE	8.3	150E
677C574G02	8CLE-200E	5981C23G01	—	CLE	8.3	200E
677C574G04	8CLE-100E	5981C17G08	—	CLE	8.3	100E
677C578G01	5CLS-18R	304C463G01	—	CLS	5.08	18R(390)
677C578G02	5CLS-24R	304C463G02	—	CLS	5.08	24R(450)
677C579G02	5CLE-50E	5981C65G02	—	CLE	5.5	50E
677C579G03	5CLE-65E	5981C65G03	—	CLE	5.5	65E
677C579G04	5CLE-80E	5981C65G04	—	CLE	5.5	80E
677C579G05	5CLE100E	5981C65G05	—	CLE	5.5	100E
677C579G06	5CLE-125E	5981C65G06	—	CLE	5.5	125E
677C579G07	5CLE-150E	5981C65G07	—	CLE	5.5	150E
677C579G08	5CLE-200E	5981C65G08	—	CLE	5.5	200E
677C579G09	Obsolete—contact Eaton	—	5CLE1-225E	—	—	—
677C579G10	5CLE-30E	5981C29G05	—	CLE	5.5	30E
677C580G01	5CLE-250E	5981C65G09	—	CLE	5.5	250E
677C580G02	5CLE-300E	5981C67G01	—	CLE	5.5	300E
677C580G03	5CLE-350E	5981C67G02	—	CLE	5.5	350E
677C580G04	Obsolete—contact Eaton	—	5CLE2-365E	—	—	—
677C580G05	5CLE-400E	5981C67G03	—	CLE	5.5	400E
677C591G01	2CLE-10E	5981C29G01	—	CLE	2.75	10E
677C592G01	2NCLPT-.25E	677C592G01	—	CLPT	2.75	0.25E
677C592G02	2NCLPT-.5E	677C592G02	—	CLPT	2.75	0.5E
677C592G03	2NCLPT-1E	677C592G03	—	CLPT	2.75	1E
677C592G04	2NCLPT-2E	677C592G04	—	CLPT	2.75	2E
677C592G05	5NCLPT-.5E	7186A29G01	—	CLPT	5.5	0.5E
677C592G06	Obsolete—contact Eaton	—	5NCLPT-0.25E	—	—	—
677C592G07	2NCLPT-.5E	677C592G07	—	CLPT	2.75	.5E
677C592G08	2NCLPT-5E	677C592G08	—	CLPT	2.75	5E
677C592G09	5NCLPT-2E	7186A29G03	—	CLPT	5.5	2E
677C592G10	8NCLPT-2E	677C592G10	—	CLPT	8.3	2E
677C592G11	8NCLPT-4E	677C592G11	—	CLPT	8.3	4E
677C592G12	5NCLPT-4E	7186A29G05	—	CLPT	5.5	4E
677C593G01	Obsolete—contact Eaton	—	6CLV-2E	—	—	—
677C593G02	Obsolete—contact Eaton	—	6CLV-5E	—	—	—
677C593G03	Obsolete—contact Eaton	—	6CLV-7E	—	—	—
677C593G04	Obsolete—contact Eaton	—	6CLV-10E	—	—	—

Appendix 2—Superseded Style Number Index

Old 10 Digit Style Number	Current Eaton Catalog Number	Eaton 10 Digit Style Number	Description	Type	Voltage Rating kV Max.	Current Rating Amperes
677C593G05	Obsolete—contact Eaton	—	6CLV-15	—	—	—
677C593G06	Obsolete—contact Eaton	—	6CLV-20	—	—	—
677C605G01	Obsolete—contact Eaton	—	8BA8-NH	—	—	—
677C605G02	Obsolete—contact Eaton	—	15BA8-NH	—	—	—
677C605G03	Obsolete—contact Eaton	—	25BA8-NH	—	—	—
677C605G04	Obsolete—contact Eaton	—	38BA8-NH	—	—	—
678C240G01	2CLE-15E	678C240G01	—	CLE	2.75	15E
678C240G02	2CLE-20E	678C240G02	—	CLE	2.75	20E
678C240G03	2CLE-25E	678C240G03	—	CLE	2.75	25E
678C240G04	5CLE-15E	678C240G04	—	CLE	5.5	15E
678C240G05	5CLE-20E	678C240G05	—	CLE	5.5	20E
678C240G06	5CLE-25E	678C240G06	—	CLE	5.5	25E
678C240G07	8CLE-15E	678C240G07	—	CLE	8.3	15E
678C240G08	8CLE-20E	678C240G08	—	CLE	8.3	20E
678C240G09	8CLE-25E	678C240G09	—	CLE	8.3	25E
678C240G10	15CLE-15E	678C240G10	—	CLE	15.5	15E
678C240G11	15CLE-20E	678C240G11	—	CLE	15.5	20E
678C240G12	15CLE-25E	678C240G12	—	CLE	15.5	25E
678C245G01	Obsolete—contact Eaton	—	8CLTB-20	—	—	—
678C245G02	Obsolete—contact Eaton	—	15CLTB-30	—	—	—
678C245G03	Obsolete—contact Eaton	—	12CLTB-30	—	—	—
678C248G01	2CLT-5	678C248G01	—	CLT	2.75	5
678C248G03	8CLT-5	678C248G03	—	CLT	8.3	5
678C248G05	5CLT-8	678C248G05	—	CLT	5.5	8
678C248G06	8CLT-8	678C248G06	—	CLT	8.3	8
678C249G01	2CLT-12	678C249G01	—	CLT	2.75	12
678C249G03	5CLT-12	678C249G03	—	CLT	5.5	12
678C276G01	2CLT-18	678C276G01	—	CLT	2.75	18
678C276G02	5CLT-18	678C276G02	—	CLT	5.5	18
678C276G03	8CLT-18	678C276G03	—	CLT	8.3	18
678C276G04	2CLT-25	678C276G04	—	CLT	2.75	25
678C276G05	5CLT-25	678C276G05	—	CLT	5.5	25
678C276G06	8CLT-25	678C276G06	—	CLT	8.3	25
678C277G01	2CLT-30	678C277G01	—	CLT	2.75	30
678C281G02	5CLE-15E	678C240G04	—	CLT	5.5	15
678C282G01	2CLT-75	678C282G01	—	CLT	2.75	75
678C283G01	8RBA4-SHNT	678C283G01	—	RBA4	8.3	400
678C283G02	15RBA4-SHNT	678C283G02	—	RBA5	15.5	400
678C283G03	25RBA4-SHNT	678C283G03	—	RBA6	25.5	300
678C283G04	38RBA4-SHNT	678C283G04	—	RBA7	38	300
678C283G05	8RBA4-ISHNT	678C283G05	—	RBA8	8.3	400
678C283G06	15RBA4-ISHNT	678C283G06	—	RBA9	15.5	400
678C283G07	25RBA4-ISHNT	678C283G07	—	RBA10	25.5	300
678C283G08	38RBA4-ISHNT	678C283G08	—	RBA11	38	300
678C284G01	8RDB4-SHNT	678C284G01	—	RBA12	8.3	400
678C284G02	15RDB4-SHNT	678C284G02	—	RBA13	15.5	400
678C284G03	25RDB4-SHNT	678C284G03	—	RBA14	25.5	300
678C284G04	38RDB4-SHNT	678C284G04	—	RBA15	38	300
678C290G01	8CLT-30CL	678C290G01	—	CLT	8.3	30
678C292G01	2CLE-450X	449D797G18	—	CLE	2.75	450X
678C292G02	5CLE-450E	5981C67G04	—	CLE	5.5	450E
678C292G03	5CLE-400E	5981C67G03	—	CLE	5.5	400E
678C295G02	15CLT-12	678C295G02	—	CLT	15.5	12

Appendix 2—Superseded Style Number Index

Old 10 Digit Style Number	Current Eaton Catalog Number	Eaton 10 Digit Style Number	Description	Type	Voltage Rating kV Max.	Current Rating Amperes
678C295G03	15CLT-8	678C295G03	—	CLT	15.5	8
678C295G04	15CLT-5	678C295G04	—	CLT	15.5	5
678C295G05	15CLT-4	678C295G05	—	CLT	15.5	4
678C295G07	15CLT-10	678C295G07	—	CLT	15.5	10
678C305G01	Obsolete—contact Eaton	—	5NCLPT-5E special	—	—	—
678C310G01	5AHLE-30E	5981C46G05	—	HLE	5.5	30E
678C310G02	5AHLE-50E	5981C46G07	—	HLE	5.5	50E
678C310G03	5AHLE-65E	5981C46G08	—	HLE	5.5	65E
678C310G04	5AHLE-80E	5981C46G09	—	HLE	5.5	80E
678C310G05	5AHLE-100E	5981C46G10	—	HLE	5.5	100E
678C310G06	5AHLE-125E	5981C46G11	—	HLE	5.5	125E
678C310G07	5AHLE-150E	5981C46G12	—	HLE	5.5	150E
678C310G08	5AHLE-200E	5981C46G14	—	HLE	5.5	200E
678C310G09	Obsolete—contact Eaton	—	5ACLE-225E	—	—	—
680C386G01	8CLT30-CS	680C386G01	—	CLT	8.3	30
680C386G02	5CLT-30	680C386G02	—	CLT	5.5	30
680C386G03	5CLT-60	680C386G03	—	CLT	5.5	60
680C386G04	Obsolete—contact Eaton	—	8CLT-60	—	—	—
680C386G05	5CLT-45	680C386G05	—	CLT	5.5	45
680C386G06	8CLT-45	680C386G06	—	CLT	8.3	45
680C387G01	2CLT-150	680C387G01	—	CLT	2.75	150
680C387G02	2CLT-90	680C387G02	—	CLT	2.75	90
6911D50G02	Obsolete—contact Eaton	—	15CLTX-15K—spade-to-spade	—	—	—
6911D50G03	Obsolete—contact Eaton	—	8CLTX-15K—spade-to-spade	—	—	—
6911D50G04	Obsolete—contact Eaton	—	8CLTX-40K—spade-to-spade	—	—	—
6911D50G05	Obsolete—contact Eaton	—	15CLTX-40K—spade-to-spade	—	—	—
6911D50G06	Obsolete—contact Eaton	—	23CLTX-15K—spade-to-spade	—	—	—
6911D50G07	Obsolete—contact Eaton	—	8CLTX-25K—spade-to-spade	—	—	—
6911D50G08	Obsolete—contact Eaton	—	15CLTX-25K—spade-to-spade	—	—	—
692C771G01	Obsolete—contact Eaton	—	DBU condenser	—	—	—
7184A64G01	5CLE-30E	5981C29G05	LCU 30E<=>5CLE-30E fuse private labelled for Littelfuse	—	—	—
7184A64G02	5CLE-50E	5981C65G02	LCU 50E<=>5CLE-50E fuse private labelled for Littelfuse	—	—	—
7184A64G03	5CLE-100E	5981C65G05	LCU 100E<=>5CLE-100E fuse private labelled for Littelfuse	—	—	—
7184A64G04	5CLE-150E	5981C65G07	LCU 150E<=>5CLE-150E fuse private labelled for Littelfuse	—	—	—
7184A64G05	5CLE-200E	5981C65G09	LCU 200E<=>5CLE-200E fuse private labelled for Littelfuse	—	—	—
7184A64G06	Obsolete—contact Eaton	—	LCU 225E<=>5CLE1-225E fuse private labelled for Littelfuse	—	—	—
7184A64G07	5CLE-300E	5981C67G01	LCU 300E<=>5CLE-300E fuse private labelled for Littelfuse	—	—	—
7184A64G08	5HLE-400E	5981C66G03	LCY 400E<=>5HLE-400E fuse private labelled for Littelfuse	—	—	—
7184A64G09	5CLE-400E	5981C67G03	LCU 400E<=>5CLE-400E fuse private labelled for Littelfuse	—	—	—
7184A64G10	5CLE-600E	449D595G02	LCU 600E<=>5CLE-600E fuse private labelled for Littelfuse	—	—	—
7184A64G11	5CLE-750E	449D595G01	LCU 750E<=>5CLE-750E fuse private labelled for Littelfuse	—	—	—
7184A64G12	15CLE-30E	5981C33G05	LCN 30E<=>5CLE-30E fuse private labelled for Littelfuse	—	—	—
7184A64G13	15CLE-40E	5981C65G01	LCN 34E<=>5CLE-34E fuse private labelled for Littelfuse	—	—	—
7184A64G14	15CLE-50E	5981C65G02	LCN 50E<=>5CLE-35E fuse private labelled for Littelfuse	—	—	—
7184A64G15	15CLE-65E	5981C65G03	LCN 65E<=>5CLE-65E fuse private labelled for Littelfuse	—	—	—
7184A64G16	15CLE2-80E	439D482G04	LCN 80E<=>5CLE-80E fuse private labelled for Littelfuse	—	—	—

Appendix 2—Superseded Style Number Index

Old 10 Digit Style Number	Current Eaton Catalog Number	Eaton 10 Digit Style Number	Description	Type	Voltage Rating kV Max.	Current Rating Amperes
7184A64G17	15CLE2-100E	439D482G05	LCN 100E<=>5CLE-100E fuse private labelled for Littelfuse	—	—	—
7184A64G18	15CLE2-125E	439D482G06	LCN 125E<=>5CLE-125E fuse private labelled for Littelfuse	—	—	—
7184A64G19	15CLE3-150E	591C376G02	LCN 150E<=>5CLE-150E fuse private labelled for Littelfuse	—	—	—
7184A64G20	15CLE3-175E	591C376G01	LCN 175E<=>5CLE-175E fuse private labelled for Littelfuse	—	—	—
7184A64G21	2CLE-10E	449D797G11	LCX 10E<=>2CLE-10E fuse private labelled for Littelfuse	—	—	—
7184A64G22	2CLE-15E	678C240G01	LCX 15E<=>2CLE-15E fuse private labelled for Littelfuse	—	—	—
7184A64G23	2CLE-30E	449D797G02	LCX 30E<=>2CLE-30E fuse private labelled for Littelfuse	—	—	—
7184A64G24	2CLE-250E	449D797G13	LCX 250E<=>2CLE-250E fuse private labelled for Littelfuse	—	—	—
7184A64G25	5HLE-65E	5981C64G03	LCY 65E<=>5HLE-65E fuse private labelled for Littelfuse	—	—	—
7184A64G26	5HLE-80E	5981C64G04	LCY 80E<=>5HLE-80E fuse private labelled for Littelfuse	—	—	—
7184A64G27	5HLE-100E	5981C64G05	LCY 100E<=>5HLE-100E fuse private labelled for Littelfuse	—	—	—
7184A64G28	5HLE-125E	5981C64G06	LCY 125E<=>5HLE-125E fuse private labelled for Littelfuse	—	—	—
7184A64G29	5HLE-150E	5981C64G07	LCY 150E<=>5HLE-150E fuse private labelled for Littelfuse	—	—	—
7184A64G30	5HLE-200E	5981C64G09	LCY 200E<=>5HLE-200E fuse private labelled for Littelfuse	—	—	—
7184A64G31	5CLE-200E	5981C65G09	LCU 200E<=>5CLE-200E fuse private labelled for Littelfuse	—	—	—
7184A64G32	8CLE-20E	678C140G08	LCZ 20E<=>8CLE-20E fuse private labelled for Littelfuse	—	—	—
7184A64G33	2CLE-65E	449D797G04	LCX 65E<=>2CLE-65E fuse private labelled for Littelfuse	—	—	—
7184A64G34	2CLE-400X	449D797G17	LCX400X<=>2CLE-400X fuse private labelled for Littelfuse	—	—	—
7184A64G35	2CLE-20E	678C240G02	LCX 20E<=>2CLE-20E fuse private labelled for Littelfuse	—	—	—
7184A64G36	2CLE-25E	678C240G03	LCX 25E<=>2CLE-25E fuse private labelled for Littelfuse	—	—	—
7184A64G37	2CLE-50E	449D797G03	LCX 50E<=>2CLE-50E fuse private labelled for Littelfuse	—	—	—
7184A64G38	2CLE80E	449D797G05	LCX 80E<=>2CLE-80E fuse private labelled for Littelfuse	—	—	—
7184A64G39	2CLE-100E	449D797G06	LCX 100E<=>2CLE-100E fuse private labelled for Littelfuse	—	—	—
7184A64G40	2CLE-125E	449D797G07	LCX 125E<=>2CLE-125E fuse private labelled for Littelfuse	—	—	—
7184A64G41	2CLE-150E	449D797G08	LCX 150E<=>2CLE-150E fuse private labelled for Littelfuse	—	—	—
7184A64G42	2CLE-200E	449D797G09	LCX 200E<=>2CLE-200E fuse private labelled for Littelfuse	—	—	—
7184A64G43	2CLE-300E	449D797G14	LCX 300E<=>2CLE-300E fuse private labelled for Littelfuse	—	—	—
7184A64G44	5CLE-65E	5981C65G03	LCU 65E<=>5CLE-65E fuse private labelled for Littelfuse	—	—	—
7184A64G45	5CLE-80E	5981C65G04	LCU 80E<=>5CLE-80E fuse private labelled for Littelfuse	—	—	—
7184A65G01	2NCLPT-.5E	677C592G02	LCD -1/2E-4<=>2NCLPT-.5E fuse private labelled for Littelfuse	—	—	—
7184A65G02	2NCLPT-1E	677C592G03	LCD -1E-4<=>2NCLPT-1E fuse private labelled for Littelfuse	—	—	—
7184A65G03	2NCLPT-2E	677C592G04	LCD -2E-4<=>2NCLPT-2E fuse private labelled for Littelfuse	—	—	—
7184A65G04	2NCLPT-5E	677C592G08	LCD -5E-4<=>2NCLPT-5E fuse private labelled for Littelfuse	—	—	—
7184A65G05	5CLPT-.5E	677C452G01	LCQ -1/2E-4<=>5CLPT-.5E fuse private labelled for Littelfuse	—	—	—
7184A65G06	5NCLPT-.5E	7186A29G01	LCE -1/2E-4<=>5NCLPT-.5E fuse private labelled for Littelfuse	—	—	—
7184A65G07	5CLPT-1E	677C452G01	LCQ -1E-4<=>5CLPT-1E fuse private labelled for Littelfuse	—	—	—
7184A65G08	5NCLPT-2E	7186A29G03	LCE -2E-4<=>5NCLPT-2E fuse private labelled for Littelfuse	—	—	—
7184A65G09	5CLPT-5E	677C453G01	LCQ -5E-4<=>5CLPT-5E fuse private labelled for Littelfuse	—	—	—
7184A65G10	5CLPT-10E	677C453G04	LCQ -10E-4<=>5CLPT-10E fuse private labelled for Littelfuse	—	—	—
7184A65G11	8CLPT-.5E	677C452G02	LCQ -1/2E-4<=>8CLPT-.5E fuse private labelled for Littelfuse	—	—	—

Appendix 2—Superseded Style Number Index

Old 10 Digit Style Number	Current Eaton Catalog Number	Eaton 10 Digit Style Number	Description	Type	Voltage Rating kV Max.	Current Rating Amperes
7184A65G12	15CLPT-5E	677C452G03	LCT -1/2E-<=>15CLPT-5E fuse private labelled for Littelfuse	—	—	—
7184A65G13	15CLPT-1E	677C452G08	LCT -1E-<=>15CLPT-1E fuse private labelled for Littelfuse	—	—	—
7184A65G14	15CLPT-3E	677C453G09	LCT -3E-<=>15CLPT-3E fuse private labelled for Littelfuse	—	—	—
7184A65G15	15CLPT-5E	677C452G03	LCT -5E-<=>15CLPT-5E fuse private labelled for Littelfuse	—	—	—
7184A65G16	15CLPT-10E	677C452G06	LCT -10E-<=>15CLPT-10E fuse private labelled for Littelfuse	—	—	—
7184A65G17	25CLPT-5E	677C452G03	LCJ -1/2E-<=>25CLPT-5E fuse private labelled for Littelfuse	—	—	—
7184A65G18	25CLPT-1E	677C452G08	LCJ -1E-<=>25CLPT-1E fuse private labelled for Littelfuse	—	—	—
7184A66G01	2CLS-2R	591C812G02	LCK -2R-<=>2CLS-2R fuse private labelled for Littelfuse	—	—	—
7184A66G02	2CLS-3R	591C812G03	LCK -3R-<=>2CLS-3R fuse private labelled for Littelfuse	—	—	—
7184A66G03	2CLS-4R	591C812G04	LCK -4R-<=>2CLS-4R fuse private labelled for Littelfuse	—	—	—
7184A66G04	5ACLS-2R	449D597G02	LCL -2R-1-<=>5ACLS-2R fuse private labelled for Littelfuse	—	—	—
7184A66G05	5ACLS-3R	449D597G03	LCL -3R-1-<=>5ACLS-3R fuse private labelled for Littelfuse	—	—	—
7184A66G06	5ACLS-4R	449D597G04	LCL -4R-1-<=>5ACLS-4R fuse private labelled for Littelfuse	—	—	—
7184A66G07	5ACLS-5R	449D597G05	LCL -5R-1-<=>5ACLS-5R fuse private labelled for Littelfuse	—	—	—
7184A66G08	5ACLS-6R	449D597G06	LCL -6R-1-<=>5ACLS-6R fuse private labelled for Littelfuse	—	—	—
7184A66G09	5ACLS-9R	151D933G01	LCL -9R-1-<=>5ACLS-9R fuse private labelled for Littelfuse	—	—	—
7184A66G10	5ACLS-12R	151D933G02	LCL -12R-1-<=>5ACLS-12R fuse private labelled for Littelfuse	—	—	—
7184A66G11	5ACLS-18R	151D933G03	LCL -18R-1-<=>5ACLS-18R fuse private labelled for Littelfuse	—	—	—
7184A66G12	5ACLS-24R	151D933G04	LCL -24R-1-<=>5ACLS-24R fuse private labelled for Littelfuse	—	—	—
7184A66G13	5CLS70-36R	140D045G02	LCL -36R-1-<=>5CLS70-36R fuse private labelled for Littelfuse	—	—	—
7184A66G14	2CLS-5R	591C812G05	LCK -5R-<=>2CLS-5R fuse private labelled for Littelfuse	—	—	—
7184A66G15	2CLS-6R	591C812G06	LCK -6R-<=>2CLS-6R fuse private labelled for Littelfuse	—	—	—
7184A66G16	2CLS-9R	591C812G07	LCK -9R-<=>2CLS-9R fuse private labelled for Littelfuse	—	—	—
7184A66G17	2CLS-12R	591C812G08	LCK -12R-<=>2CLS-12R fuse private labelled for Littelfuse	—	—	—
7184A66G18	2CLS-18R	591C813G01	LCK -18R-<=>2CLS-18R fuse private labelled for Littelfuse	—	—	—
7184A66G19	2CLS-24R	591C813G02	LCK -24R-<=>2CLS-24R fuse private labelled for Littelfuse	—	—	—
7184A66G20	5CLS-2R	151D241G02	LCL-2R<=>5CLS-2R fuse private labelled for Littelfuse	—	—	—
7184A66G21	5CLS-3R	151D241G03	LCL-3R<=>5CLS-3R fuse private labelled for Littelfuse	—	—	—
7184A66G22	5CLS-4R	151D241G04	LC -4R<=>5CLS-4R fuse private labelled for Littelfuse	—	—	—
7184A66G23	5CLS-5R	151D241G05	LC -5R<=>5CLS-5R fuse private labelled for Littelfuse	—	—	—
7184A66G24	5CLS-6R	151D241G06	LCL-6R<=>5CLS-6R fuse private labelled for Littelfuse	—	—	—
7184A66G25	5CLS-9R	151D961G01	LCL-9R<=>5CLS-9R fuse private labelled for Littelfuse	—	—	—
7184A66G26	5CLS-12R	151D961G02	LCL-12R<=>5CLS-12R fuse private labelled for Littelfuse	—	—	—
7184A66G27	5CLS-18R	151D961G03	LCL-18R<=>5CLS-18R fuse private labelled for Littelfuse	—	—	—
7184A66G28	5CLS-24R	151D961G04	LCL-24R<=>5CLS-24R fuse private labelled for Littelfuse	—	—	—
7185A11G01	5HLE-30E	5981C28G03	LCY-30E<=>5HLE-30E fuse private labelled for Littelfuse	—	—	—
7185A11G02	5HLE-40E	5981C64G01	LCY-40E<=>5HLE-340E fuse private labelled for Littelfuse	—	—	—
7185A11G03	5HLE-50E	5981C64G02	LCY-50E<=>5HLE-50E fuse private labelled for Littelfuse	—	—	—
7185A11G04	5HLE-250E	5981C64G10	LCY-250E<=>5HLE-250E fuse private labelled for Littelfuse	—	—	—
7185A11G05	5HLE-300E	5981C66G01	LCY-300E<=>5HLE-300E fuse private labelled for Littelfuse	—	—	—
7185A11G06	5HLE-450E	5981C66G04	LCY-450E<=>5HLE-450E fuse private labelled for Littelfuse	—	—	—
7185A11G07	15HLE-20E	5981C32G03	LDN-20E<=>15HLE-20E fuse private labelled for Littelfuse	—	—	—

Appendix 2—Superseded Style Number Index

Old 10 Digit Style Number	Current Eaton Catalog Number	Eaton 10 Digit Style Number	Description	Type	Voltage Rating kV Max.	Current Rating Amperes
7185A11G08	15HLE-25E	5981C32G04	LDN-25E<=>15HLE-25E fuse private labelled for Littelfuse	—	—	—
7185A11G09	15HLE-30E	5981C32G05	LDN-30E<=>15HLE-30E fuse private labelled for Littelfuse	—	—	—
7185A11G10	15HLE-40E	5981C18G04	LDN-40E<=>15HLE-40E fuse private labelled for Littelfuse	—	—	—
7185A11G11	15HLE-50E	5981C18G05	LDN-50E<=>15HLE-50E fuse private labelled for Littelfuse	—	—	—
7185A11G12	15HLE-65E	5981C18G06	LDN-65E<=>15HLE-65E fuse private labelled for Littelfuse	—	—	—
7185A11G13	15HLE-80E	5981C18G07	LDN-80E<=>15HLE-80E fuse private labelled for Littelfuse	—	—	—
7185A11G14	15HLE-100E	5981C18G08	LDN-100E<=>15HLE-100E fuse private labelled for Littelfuse	—	—	—
7185A11G15	15HLE-150E	5981C44G01	LDN-150E<=>15HLE-150E fuse private labelled for Littelfuse	—	—	—
7185A11G16	15HLE-175E	5981C44G02	LDN-175E<=>15HLE-175E fuse private labelled for Littelfuse	—	—	—
7185A11G17	8HLE-25E	5981C30G04	LDZ-25E<=>8HLE-25E fuse private labelled for Littelfuse	—	—	—
7185A11G18	8HLE-30E	5981C30G05	LDZ-30E<=>8HLE-30E fuse private labelled for Littelfuse	—	—	—
7185A11G19	8HLE-40E	5981C16G04	LDZ-40E<=>8HLE-40E fuse private labelled for Littelfuse	—	—	—
7185A11G20	8HLE-50E	5981C16G05	LDZ-50E<=>8HLE-50E fuse private labelled for Littelfuse	—	—	—
7185A11G21	8HLE-65E	5981C16G06	LDZ-65E<=>8HLE-65E fuse private labelled for Littelfuse	—	—	—
7185A11G22	8HLE-80E	5981C16G07	LDZ-80E<=>8HLE-80E fuse private labelled for Littelfuse	—	—	—
7185A11G23	8HLE-100E	5981C16G08	LDZ-100E<=>8HLE-100E fuse private labelled for Littelfuse	—	—	—
7185A11G24	8HLE-125E	5981C16G09	LDZ-125E<=>8HLE-125E fuse private labelled for Littelfuse	—	—	—
7185A11G25	8HLE-150E	5981C16G10	LDZ-150E<=>8HLE-150E fuse private labelled for Littelfuse	—	—	—
7185A11G26	8HLE-175E	5981C16G11	LDZ-175E<=>8HLE-175E fuse private labelled for Littelfuse	—	—	—
7185A11G27	8HLE-200E	5981C22G01	LDZ-200E<=>8HLE-200E fuse private labelled for Littelfuse	—	—	—
7185A11G28	8HLE-250E	5981C22G02	LDZ-250E<=>8HLE-250E fuse private labelled for Littelfuse	—	—	—
7185A11G29	8HLE-300E	5981C22G03	LDZ-300E<=>8HLE-300E fuse private labelled for Littelfuse	—	—	—
7185A11G30	8HLE-350E	5981C22G04	LDZ-350E<=>8HLE-350E fuse private labelled for Littelfuse	—	—	—
7185A11G31	8HLE-20E	5981C30G03	LDZ-20E<=>8HLE-20E fuse private labelled for Littelfuse	—	—	—
7185A11G32	8CLE-15E	678C248G07	LCZ-15E<=>8CLE-15E fuse private labelled for Littelfuse	—	—	—
7185A11G33	8CLE-25E	678C248G09	LCZ-25E<=>8CLE-25E fuse private labelled for Littelfuse	—	—	—
7185A11G34	8CLE-30E	5981C32G05	LCZ-30E<=>8CLE-30E fuse private labelled for Littelfuse	—	—	—
7185A11G35	8CLE-40E	5981C17G04	LCZ-40E<=>8CLE-40E fuse private labelled for Littelfuse	—	—	—
7185A11G36	8CLE-50E	5981C17G05	LCZ-50E<=>8CLE-50E fuse private labelled for Littelfuse	—	—	—
7185A11G37	8CLE-65E	5981C17G06	LCZ-65E<=>8CLE-65E fuse private labelled for Littelfuse	—	—	—
7185A11G38	8CLE-80E	5981C17G07	LCZ-80E<=>8CLE-80E fuse private labelled for Littelfuse	—	—	—
7185A11G39	8CLE-100E	5981C17G08	LCZ-100E<=>8CLE-100E fuse private labelled for Littelfuse	—	—	—
7185A11G40	8CLE-125E	5981C17G09	LCZ-125E<=>8CLE-125E fuse private labelled for Littelfuse	—	—	—
7185A11G41	8CLE-150E	5981C17G10	LCZ-150E<=>8CLE-150E fuse private labelled for Littelfuse	—	—	—
7185A11G42	8CLE-200E	5981C23G01	LCZ-200E<=>8CLE-200E fuse private labelled for Littelfuse	—	—	—
7185A43G01	5HLE-10E	5981C28G01	LCY-10E <=> 5HLE-10E-N fuse private labelled for Littelfuse	—	—	—
7185A43G02	5HLE-15E	5981C28G02	LCY-15E <=> 5HLE-15E-N fuse private labelled for Littelfuse	—	—	—
7185A43G03	5HLE-20E	5981C28G03	LCY-20E <=> 5HLE-20E-N fuse private labelled for Littelfuse	—	—	—
7185A43G04	5HLE-25E	5981C28G04	LCY-25E <=> 5HLE-25E-N fuse private labelled for Littelfuse	—	—	—
7185A43G05	5HLE-30E	5981C28G05	LCY-30E <=> 5HLE-30E-N fuse private labelled for Littelfuse	—	—	—
7185A43G06	5HLE-40E	5981C65G01	LCY-40E <=> 5HLE-40E-N fuse private labelled for Littelfuse	—	—	—

Appendix 2—Superseded Style Number Index

Old 10 Digit Style Number	Current Eaton Catalog Number	Eaton 10 Digit Style Number	Description	Type	Voltage Rating kV Max.	Current Rating Amperes
7185A43G07	5HLE-50E	5981C65G02	LCY-50E <=> 5HLE-50E-N fuse private labelled for Littelfuse	—	—	—
7185A43G08	5HLE-65E	5981C65G03	LCY-65E <=> 5HLE-65E-N fuse private labelled for Littelfuse	—	—	—
7185A43G09	5HLE-80E	5981C65G04	LCY-80E <=> 5HLE-80E-N fuse private labelled for Littelfuse	—	—	—
7185A43G10	5HLE-100E	5981C65G05	LCY-100E <=> 5HLE-100E-N fuse private labelled for Littelfuse	—	—	—
7185A44G01	8HLE-10E	5981C30G01	LDZ-10E <=> 8HLE-10E-N fuse private labelled for Littelfuse	—	—	—
7185A44G02	8HLE-15E	5981C30G02	LDZ-15E <=> 8HLE-15E-N fuse private labelled for Littelfuse	—	—	—
7185A44G03	8HLE-20E	5981C30G03	LDZ-20E <=> 8HLE-20E-N fuse private labelled for Littelfuse	—	—	—
7185A44G04	8HLE-25E	5981C30G04	LDZ-25E <=> 8HLE-25E-N fuse private labelled for Littelfuse	—	—	—
7185A44G05	8HLE-30E	5981C30G05	LDZ-30E <=> 8HLE-30E-N fuse private labelled for Littelfuse	—	—	—
7185A44G06	8HLE-40E	5981C16G01	LDZ-40E <=> 8HLE-40E-N fuse private labelled for Littelfuse	—	—	—
7185A44G07	8HLE-50E	5981C16G02	LDZ-50E <=> 8HLE-50E-N fuse private labelled for Littelfuse	—	—	—
7185A44G08	8HLE-65E	5981C16G03	LDZ-65E <=> 8HLE-65E-N fuse private labelled for Littelfuse	—	—	—
7185A44G09	8HLE-80E	5981C16G04	LDZ-80E <=> 8HLE-80E-N fuse private labelled for Littelfuse	—	—	—
7185A44G10	8HLE-100E	5981C16G05	LDZ-100E <=> 8HLE-100E-N fuse private labelled for Littelfuse	—	—	—
7185A45G01	15HLE-10E	5981C32G01	LDN-10E <=> 15HLE-10E-N fuse private labelled for Littelfuse	—	—	—
7185A45G02	15HLE-15E	5981C32G02	LDN-15E <=> 15HLE-15E-N fuse private labelled for Littelfuse	—	—	—
7185A45G03	15HLE-20E	5981C32G03	LDN-20E <=> 15HLE-20E-N fuse private labelled for Littelfuse	—	—	—
7185A45G04	15HLE-25E	5981C32G04	LDN-25E <=> 15HLE-25E-N fuse private labelled for Littelfuse	—	—	—
7185A45G05	15HLE-30E	5981C32G05	LDN-30E <=> 15HLE-30E-N fuse private labelled for Littelfuse	—	—	—
7185A45G06	15HLE-40E	5981C18G01	LDN-40E <=> 15HLE-40E-N fuse private labelled for Littelfuse	—	—	—
7185A45G07	15HLE-50E	5981C18G02	LDN-50E <=> 15HLE-50E-N fuse private labelled for Littelfuse	—	—	—
7185A45G08	15HLE-65E	5981C18G03	LDN-65E <=> 15HLE-65E-N fuse private labelled for Littelfuse	—	—	—
7185A45G09	15HLE-80E	5981C18G04	LDN-80E <=> 15HLE-80E-N fuse private labelled for Littelfuse	—	—	—
7185A45G10	15HLE-100E	5981C18G05	LDN-100E <=> 15HLE-100E-N fuse private labelled for Littelfuse	—	—	—
7185A48G01	5CLE-10E-D	5981C29G01	LCU-10E<=>5CLE-10E-D fuse private labelled for Littelfuse	—	—	—
7185A48G02	5CLE-15E	678C240G04	LCU-15E<=>5CLE-15E fuse private labelled for Littelfuse	—	—	—
7185A48G03	5CLE-20E	678C240G05	LCU-20E<=>5CLE-20E fuse private labelled for Littelfuse	—	—	—
7185A48G04	5CLE-25E	678C240G06	LCU-25E<=>5CLE-25E fuse private labelled for Littelfuse	—	—	—
7185A48G05	5CLE-40E	5981C65G01	LCU-40E<=>5CLE-40E fuse private labelled for Littelfuse	—	—	—
7185A48G06	5CLE-125E	5981C65G06	LCU-125E<=>5CLE-125E fuse private labelled for Littelfuse	—	—	—
7185A48G07	15CLE-15E	678C240G10	LCN-15E<=>15CLE-15E fuse private labelled for Littelfuse	—	—	—
7185A48G08	15CLE-20E	678C240G11	LCN-20E<=>15CLE-20E fuse private labelled for Littelfuse	—	—	—
7185A48G09	15CLE-25E	678C240G12	LCN-25E<=>15CLE-25E fuse private labelled for Littelfuse	—	—	—
7185A48G10	15CLE-80E	5981C19G07	LCN-80ES<=>15CLE-80E fuse private labelled for Littelfuse	—	—	—

Appendix 2—Superseded Style Number Index

Old 10 Digit Style Number	Current Eaton Catalog Number	Eaton 10 Digit Style Number	Description	Type	Voltage Rating kV Max.	Current Rating Amperes
7185A48G11	15CLE-100E	5981C19G08	LCN-100ES<=>15CLE-100E fuse private labelled for Littelfuse	—	—	—
7185A48G12	15CLE-125E	5981C19G09	LCN-125ES<=>15CLE-125E fuse private labelled for Littelfuse	—	—	—
7185A48G13	15CLE-150E	5981C19G10	LCN-150ES<=>15CLE-150E fuse private labelled for Littelfuse	—	—	—
7185A48G14	15CLE-175E	5982C25G01	LCN-175ED<=>15CLE-175E fuse private labelled for Littelfuse	—	—	—
7185A48G15	15CLE-200E	5982C25G02	LCN-200ED<=>15CLE-200E fuse private labelled for Littelfuse	—	—	—
7185A48G16	15CLE-250E	5982C25G03	LCN-250ED<=>15CLE-250E fuse private labelled for Littelfuse	—	—	—
7185A48G17	15CLE-300E	5982C25G04	LCN-300ED<=>15CLE-300E fuse private labelled for Littelfuse	—	—	—
7185A48G18	5CLE-175E	5981C65G08	LCU-175E<=>5CLE-175E fuse private labelled for Littelfuse	—	—	—
7185A48G19	5CLE-250E	5981C65G10	LCU-250ES<=>5CLE-250E fuse private labelled for Littelfuse	—	—	—
7185A48G20	5CLE-350X	5981C67G02	LCU-350X<=>5CLE-350E fuse private labelled for Littelfuse	—	—	—
7185A48G21	Obsolete—contact Eaton	—	—	—	—	—
7185A48G22	5CLE-450E	5981C67G04	LCU-450X<=>5CLE-450E fuse private labelled for Littelfuse	—	—	—
7185A48G23	Obsolete—contact Eaton	—	—	—	—	—
7185A48G24	Obsolete—contact Eaton	—	—	—	—	—
7185A48G25	8CLE-175E	5981C17G11	LCZ-175E <=> 8CLE-175E fuse private labelled for Littelfuse	—	—	—
7185A48G26	5CL5-350E	5981C67G02	LCU-350E <=> 5CLE-350E fuse private labelled for Littelfuse	—	—	—
7185A48G27	5HLE-175E	5981C64G08	LCY-175E <=>5CLE-175E fuse private labelled for Littelfuse	—	—	—
7185A48G28	5HLE-350E	5981C66G02	LCY-350E <=> 5CLE-350E fuse private labelled for Littelfuse	—	—	—
7185A40G01	5HLE-10E	5981C28G01	—	HLE	5.5	10E
7185A40G02	5HLE-15E	5981C28G02	—	HLE	5.5	15E
7185A40G03	5HLE-20E	5981C28G03	—	HLE	5.5	20E
7185A40G04	5HLE-25E	5981C28G04	—	HLE	5.5	25E
7185A40G05	5HLE-30E	5981C28G05	—	HLE	5.5	30E
7185A40G06	5HLE-40E	5981C64G01	—	HLE	5.5	40E
7185A40G07	5HLE-50E	5981C64G02	—	HLE	5.5	50E
7185A40G08	5HLE-65E	5981C64G03	—	HLE	5.5	65E
7185A40G09	5HLE-80E	5981C64G04	—	HLE	5.5	80E
7185A40G10	5HLE-100E	5981C64G05	—	HLE	5.5	100E
7185A40G11	5AHLE-10E	5981C64G01	—	HLE	5.5	10E
7185A40G12	5AHLE-15E	5981C64G02	—	HLE	5.5	15E
7185A40G13	5AHLE-20E	5981C64G03	—	HLE	5.5	20E
7185A40G14	5AHLE-25E	5981C64G04	—	HLE	5.5	25E
7185A40G15	5AHLE-30E	5981C64G05	—	HLE	5.5	30E
7185A40G16	5AHLE-40E	5981C64G06	—	HLE	5.5	40E
7185A40G17	5AHLE-50E	5981C64G07	—	HLE	5.5	50E
7185A40G18	5AHLE-65E	5981C64G08	—	HLE	5.5	65E
7185A40G19	5AHLE-80E	5981C64G09	—	HLE	5.5	80E
7185A40G20	5AHLE-100E	5981C64G10	—	HLE	5.5	100E
7185A41G01	8HLE-10E	5981C30G01	—	HLE	8.3	10E
7185A41G02	8HLE-15E	5981C30G02	—	HLE	8.3	15E
7185A41G03	8HLE-20E	5981C30G03	—	HLE	8.3	20E
7185A41G04	8HLE-25E	5981C30G04	—	HLE	8.3	25E
7185A41G05	8HLE-30E	5981C30G05	—	HLE	8.3	30E

Appendix 2—Superseded Style Number Index

Old 10 Digit Style Number	Current Eaton Catalog Number	Eaton 10 Digit Style Number	Description	Type	Voltage Rating kV Max.	Current Rating Amperes
7185A41G06	8HLE-40E	5981C16G04	—	HLE	8.3	40E
7185A41G07	8HLE-50E	5981C16G05	—	HLE	8.3	50E
7185A41G08	8HLE-65E	5981C16G06	—	HLE	8.3	65E
7185A41G09	8HLE-80E	5981C16G07	—	HLE	8.3	80E
7185A41G10	8HLE-100E	5981C16G08	—	HLE	8.3	100E
7185A41G11	8AHLE-10E	5981C47G01	—	HLE	8.3	10E
7185A41G12	8AHLE-15E	5981C47G02	—	HLE	8.3	15E
7185A41G13	8AHLE-20E	5981C47G03	—	HLE	8.3	20E
7185A41G14	8AHLE-25E	5981C47G04	—	HLE	8.3	25E
7185A41G15	8AHLE-30E	5981C47G05	—	HLE	8.3	30E
7185A41G16	8AHLE-40E	5981C47G06	—	HLE	8.3	40E
7185A41G17	8AHLE-50E	5981C47G07	—	HLE	8.3	50E
7185A41G18	8AHLE-65E	5981C47G08	—	HLE	8.3	65E
7185A41G19	8AHLE-80E	5981C47G09	—	HLE	8.3	80E
7185A41G20	8AHLE-100E	5981C47G10	—	HLE	8.3	100E
7185A42G01	15HLE-10E	5981C32G01	—	HLE	15.5	10E
7185A42G02	15HLE-15E	5981C32G02	—	HLE	15.5	15E
7185A42G03	15HLE-20E	5981C32G03	—	HLE	15.5	20E
7185A42G04	15HLE-25E	5981C32G04	—	HLE	15.5	25E
7185A42G05	15HLE-30E	5981C32G05	—	HLE	15.5	30E
7185A42G06	15HLE-40E	5981C18G04	—	HLE	15.5	40E
7185A42G07	15HLE-50E	5981C18G05	—	HLE	15.5	50E
7185A42G08	15HLE-65E	5981C18G06	—	HLE	15.5	65E
7185A42G09	15HLE-80E	5981C18G07	—	HLE	15.5	80E
7185A42G10	15HLE-100E	5981C18G08	—	HLE	15.5	100E
7186A29G01	5NCLPT-.5E	7186A29G01	—	CLPT	5.5	.5E
7186A29G02	5NCLPT-1E	7186A29G02	—	CLPT	5.5	1E
7186A29G03	5NCLPT-2E	7186A29G03	—	CLPT	5.5	2E
7186A29G04	5NCLPT-3E	7186A29G04	—	CLPT	5.5	3E
7186A29G05	5NCLPT-4E	7186A29G05	—	CLPT	5.5	4E
7186A29G06	5NCLPT-5E	7186A29G06	—	CLPT	5.5	5E
7186A29G11	317A487H02	7186A29G11	—	CLPT	5.5	.5E
7186A29G12	317A487H06	7186A29G12	—	CLPT	5.5	1E
7186A29G13	317A487H03	7186A29G13	—	CLPT	5.5	2E
7186A29G14	317A487H04	7186A29G14	—	CLPT	5.5	3E
7186A29G15	317A487H05	7186A29G15	—	CLPT	5.5	5E
7187A11G01	DBU-EFID	7187A11G04	—	DBU	—	200
7187A11G02	DBU-EFOD	7187A11G02	—	DBU	—	200
7187A11G03	DBU-EFID	7187A11G04	—	DBU	—	200
7187A11G04	DBU-EFID	7187A11G04	—	DBU	—	200
722C373A02	2CLE-30E	449D797G02	—	CLE	2.75	30E
722C373A04	2CLE-50E	449D797G03	—	CLE	2.75	50E
722C373A05	2CLE-65E	449D797G04	—	CLE	2.75	65E
722C373A06	2CLE-80E	449D797G05	—	CLE	2.75	80E
722C373A07	2CLE-100E	449D797G06	—	CLE	2.75	100E
722C373A08	2CLE-125E	449D797G07	—	CLE	2.75	125E
722C373A09	2CLE-150E	449D797G08	—	CLE	2.75	150E
722C373A10	2CLE-200E	449D797G09	—	CLE	2.75	200E
726C972A02	5CLE-30E	5981C29G05	—	CLE	5.5	30E
726C972A04	5CLE-50E	5981C65G02	—	CLE	5.5	50E
726C972A05	5CLE-65E	5981C65G03	—	CLE	5.5	65E
726C972A06	5CLE-80E	5981C65G04	—	CLE	5.5	80E
726C972A07	5CLE100E	5981C65G05	—	CLE	5.5	100E

Appendix 2—Superseded Style Number Index

Old 10 Digit Style Number	Current Eaton Catalog Number	Eaton 10 Digit Style Number	Description	Type	Voltage Rating kV Max.	Current Rating Amperes
726C972A08	5CLE-125E	5981C65G06	—	CLE	5.5	125E
726C972A09	5CLE-150E	5981C65G07	—	CLE	5.5	150E
726C972A10	5CLE-200E	5981C65G09	—	CLE	5.5	200E
726C973A01	8CLE-30E	5981C31G05	—	CLE	8.3	30E
726C973A02	8CLE-40E	5981C17G04	—	CLE	8.3	40E
726C973A03	8CLE-50E	5981C17G05	—	CLE	8.3	50E
726C973A04	8CLE-65E	5981C17G06	—	CLE	8.3	65E
726C973A05	8CLE-80E	5981C17G07	—	CLE	8.3	80E
726C973A06	8CLE-100E	5981C17G08	—	CLE	8.3	100E
726C974A02	15CLE-30E	5981C33G05	—	CLE	15.5	30E
726C974A03	15CLE-40E	5981C19G04	—	CLE	15.5	40E
726C974A04	15CLE-50E	5981C19G05	—	CLE	15.5	50E
726C974A05	15CLE-65E	5981C19G06	—	CLE	15.5	65E
726C974A06	15CLE-80E	5981C19G07	—	CLE	15.5	80E
726C974A07	15CLE-100E	5981C19G08	—	CLE	15.5	100E
7275A85G02	CXN-CLMP	7275A85G02	—	CXN	—	—
7276A67G01	15RBA2-DL	9078A26A01	—	RBA2	—	200
7276A67G02	15RBA4-DL	9078A20A01	—	RBA2	—	200
7276A67G03	38RBA2-DL	9078A26A02	—	RBA4	—	400
7276A67G04	38RBA4-DL	9078A20A02	—	RBA4	—	300
758C433A21	15CLPT-.5E	677C452G03	—	CLPT	15.5	0.5
758C433A39	2CLE-15E	678C240G01	—	CLE	2.75	15E
758C433A40	2CLE-20E	678C240G02	—	CLE	2.75	20E
758C433A41	2CLE-25E	678C240G03	—	CLE	2.75	25E
758C433A42	5CLE-15E	678C240G04	—	CLE	5.5	15E
758C433A43	5CLE-20E	678C240G05	—	CLE	5.5	20E
758C433A44	5CLE-25E	678C240G06	—	CLE	5.5	25E
758C433A45	8CLE-15E	678C240G07	—	CLE	8.3	15E
758C433A46	8CLE-20E	678C240G08	—	CLE	8.3	20E
758C433A47	8CLE-25E	678C240G09	—	CLE	8.3	25E
758C433A48	15CLE-15E	678C240G10	—	CLE	15.5	15E
758C433A49	15CLE-20E	678C240G11	—	CLE	15.5	20E
758C433A50	15CLE-25E	678C240G12	—	CLE	15.5	25E
853C830G02	2NCLPT-1E	677C592G03	—	CLPT	2.75	1
853C830G03	2NCLPT-.5E	677C592G02	—	CLPT	2.75	0.5
853C830G07	5NCLPT-.5E	677C592G06	—	CLPT	5.5	0.5
853C832G01	Obsolete—contact Eaton	—	6CLV-2E	—	—	—
853C832G02	Obsolete—contact Eaton	—	6CLV-5E	—	—	—
853C832G03	Obsolete—contact Eaton	—	6CLV-7E	—	—	—
853C832G04	Obsolete—contact Eaton	—	6CLV-10E	—	—	—
9078A19G01	5RBA4-PDM	9078A19G01	—	RBA4	5.5	400
9078A19G02	5RBA4-GDM	9078A19G02	—	RBA4	5.5	400
9078A19G03	14RBA4-PDM	9078A19G03	—	RBA4	15.5	400
9078A19G04	14RBA4-GDM	9078A19G04	—	RBA4	15.5	400
9078A19G05	15RBA4-PDM	9078A19G05	—	RBA4	15.5	400
9078A19G06	25RBA4-PDM	9078A19G06	—	RBA4	25.5	300
9078A19G07	38RBA4-PDM	9078A19G07	—	RBA4	38	300
9078A19G08	8RBA4-PDM	9078A19G08	—	RBA4	8.3	400
9078A19G09	8RBA4-GDM	9078A19G09	—	RBA4	8.3	400
9078A20A01	15RBA4-DL	9078A20A01	—	RBA4	15.5	400
9078A20A02	38RBA4-DL	9078A20A02	—	RBA4	38	300
9078A20A03	15RBA4-LBDL	9078A20A03	—	RBA4	15.5	400
9078A25G01	5RBA2-PDM	9078A25G01	—	RBA2	5.5	200

Appendix 2—Superseded Style Number Index

Old 10 Digit Style Number	Current Eaton Catalog Number	Eaton 10 Digit Style Number	Description	Type	Voltage Rating kV Max.	Current Rating Amperes
9078A25G02	5RBA2-GDM	9078A25G02	—	RBA2	5.5	200
9078A25G03	14RBA2-PDM	9078A25G03	—	RBA2	15.5	200
9078A25G04	14RBA2-GDM	9078A25G04	—	RBA2	15.5	200
9078A25G05	15RBA2-PDM	9078A25G05	—	RBA2	15.5	200
9078A25G06	25RBA2-PDM	9078A25G06	—	RBA2	25.5	200
9078A25G07	38RBA2-PDM	9078A25G07	—	RBA2	38	200
9078A25G08	8RBA2-PDM	9078A25G08	—	RBA2	8.3	200
9078A25G09	8RBA2-GDM	9078A25G09	—	RBA2	8.3	200
9078A26A01	15RBA2-DL	9078A26A01	—	RBA2	15.5	200
9078A26A02	38RBA2-DL	9078A26A02	—	RBA2	38	200
9078A26A03	15RBA2-LBDL	9078A26A03	—	RBA2	15.5	200
9078A30A01	38RBA2-NL	9078A30A01	—	RBA2	38	200
9078A30A02	15RBA2-NL	9078A30A02	—	RBA2	15.5	200
9078A30A03	38RBA4-NL	9078A30A03	—	RBA4	38	300
9078A30A04	15RBA4-NL	9078A30A04	—	RBA4	15.5	400
9078A30A05	38RBA8-NL	9078A30A05	—	RBA8	38	540
9078A30A06	15RBA8-NL	9078A30A06	—	RBA8	15.5	720
9078A33G01	5RBA2-PNM	9078A33G01	—	RBA2	5.5	200
9078A33G02	8RBA2-PNM	9078A33G02	—	RBA2	8.3	200
9078A33G03	14RBA2-PNM	9078A33G03	—	RBA2	15.5	200
9078A33G04	25RBA2-PNM	9078A33G04	—	RBA2	25.5	200
9078A33G05	38RBA2-PNM	9078A33G05	—	RBA2	38	200
9078A33G06	5RBA4-PNM	9078A33G06	—	RBA4	5.5	400
9078A33G07	8RBA4-PNM	9078A33G07	—	RBA4	8.3	400
9078A33G08	14RBA4-PNM	9078A33G08	—	RBA4	15.5	400
9078A33G09	25RBA4-GNM	9078A33G09	—	RBA4	25.5	300
9078A33G10	38RBA4-GNM	9078A33G10	—	RBA4	38	300
9078A33G11	5RBA8-PNM	9078A33G11	—	RBA8	5.5	720
9078A33G12	8RBA8-PNM	9078A33G12	—	RBA8	8.3	720
9078A33G13	14RBA8-PNM	9078A33G13	—	RBA8	15.5	720
9078A33G14	25RBA8-GNM	9078A33G14	—	RBA8	25.5	540
9078A33G15	38RBA8-GNM	9078A33G15	—	RBA8	38	540
9078A33G16	5RBA2-GNM	9078A33G16	—	RBA2	5.5	200
9078A33G17	8RBA2-GNM	9078A33G17	—	RBA2	8.3	200
9078A33G18	14RBA2-GNM	9078A33G18	—	RBA2	15.5	200
9078A33G19	5RBA4-GNM	9078A33G19	—	RBA4	5.5	400
9078A33G20	8RBA4-GNM	9078A33G20	—	RBA4	8.3	400
9078A33G21	14RBA4-GNM	9078A33G21	—	RBA4	15.5	400
9078A33G22	5RBA8-GNM	9078A33G22	—	RBA8	5.5	720
9078A33G23	8RBA8-GNM	9078A33G23	—	RBA8	8.3	720
9078A33G24	14RBA8-GNM	9078A33G24	—	RBA8	15.5	720
9078A33G25	15RBA2-PNM	9078A33G25	—	RBA2	15.5	200
9078A33G26	15RBA4-PNM	9078A33G26	—	RBA4	15.5	400
9078A33G27	15RBA8-PNM	9078A33G27	—	RBA8	15.5	720
9078A63G01	CLPT-DF	9078A63G01	—	CLPT	—	10
9078A63G02	CLE-DF-C	9078A63G02	—	CLE	—	25
9078A63G03	CLE-DF-D	9078A63G03	—	CLE	—	250
9078A63G04	CLE-DF-E	9078A63G04	—	CLE	—	450
9078A64G01	CLPT-DL	9078A64G01	—	CLPT	—	10
9078A64G02	CLE-DL-C	9078A64G02	—	CLE	—	25
9078A64G03	CLE-DL-D	9078A64G03	—	CLE	—	250
9078A64G04	CLE-DL-E	9078A64G04	—	CLE	—	450
9078A64G12	9078A64G12	9078A64G12	Special mounting for triple barrel 15CLE3 fuse	CLE	—	200

Appendix 2—Superseded Style Number Index

Old 10 Digit Style Number	Current Eaton Catalog Number	Eaton 10 Digit Style Number	Description	Type	Voltage Rating kV Max.	Current Rating Amperes
9078A64G14	25CLPT-DL	9078A64G14	—	CLPT	25.5	1
9078A65G01	5CLPT-PDM-A	9078A65G01	—	CLPT	5.5	10
9078A65G02	8CLPT-PDM-A	9078A65G02	—	CLPT	8.3	10
9078A65G03	15CLPT-PDM-A	9078A65G03	—	CLPT	15.5	10
9078A65G04	15CLPT-HPDM-A	9078A65G04	—	CLPT	15.5	10
9078A65G05	25CLPT-HPDM-A	9078A65G05	—	CLPT	25.5	1
9078A65G06	5CLPT-PDM-A	9078A65G06	—	CLPT	5.5	10
9078A65G07	8CLPT-PDM-B	9078A65G07	—	CLPT	8.3	10
9078A65G08	15CLPT-PDM-B	9078A65G08	—	CLPT	15.5	10
9078A65G09	15CLPT-HPDM-B	9078A65G09	—	CLPT	15.5	10
9078A65G10	2CLE-PDM-C	9078A65G10	—	CLE	2.75	25
9078A65G11	5CLE-PDM-C	9078A65G11	—	CLE	5.5	25
9078A65G12	8CLE-PDM-C	9078A65G12	—	CLE	8.3	25
9078A65G13	15CLE-PDM-C	9078A65G13	—	CLE	15.5	25
9078A65G14	15CLE-HPDM-C	9078A65G14	—	CLE	15.5	25
9078A65G15	2CLE-PDM-D	9078A65G15	—	CLE	2.75	250
9078A65G16	5CLE-PDM-D	9078A65G16	—	CLE	5.5	250
9078A65G17	8CLE-PDM-D	9078A65G17	—	CLE	8.3	175
9078A65G18	15CLE-PDM-D	9078A65G18	—	CLE	15.5	150
9078A65G19	15CLE-HPDM-D	9078A65G19	—	CLE	15.5	150
9078A65G20	2CLE-PDM-E	9078A65G20	—	CLE	2.75	450
9078A65G21	5CLE-PDM-E	9078A65G21	—	CLE	5.5	450
9078A65G22	8CLE-PDM-E	9078A65G22	—	CLE	8.3	350
9078A65G23	15CLE-PDM-E	9078A65G23	—	CLE	15.5	300
9078A65G24	5CLPT-GDM-A	9078A65G24	—	CLPT	5.5	10
9078A65G25	8CLPT-GDM-A	9078A65G25	—	CLPT	8.3	2
9078A65G26	15CLPT-GDM-A	9078A65G26	—	CLPT	15.5	2
9078A65G27	5CLPT-GDM-A	9078A65G27	—	CLPT	5.5	10
9078A65G28	8CLPT-GDM-B	9078A65G28	—	CLPT	8.3	10
9078A65G29	15CLPT-GDM-B	9078A65G29	—	CLPT	15.5	10
9078A65G30	2CLE-GDM-C	9078A65G30	—	CLE	2.75	25
9078A65G31	5CLE-GDM-C	9078A65G31	—	CLE	5.5	25
9078A65G32	8CLE-GDM-C	9078A65G32	—	CLE	8.3	25
9078A65G33	15CLE-GDM-C	9078A65G33	—	CLE	15.5	25
9078A65G34	2CLE-GDM-D	9078A65G34	—	CLE	2.75	250
9078A65G35	5CLE-GDM-D	9078A65G35	—	CLE	5.5	250
9078A65G36	8CLE-GDM-D	9078A65G36	—	CLE	8.3	175
9078A65G37	15CLE-GDM-D	9078A65G37	—	CLE	15.5	150
9078A65G38	2CLE-GDM-E	9078A65G38	—	CLE	2.75	450
9078A65G39	5CLE-GDM-E	9078A65G39	—	CLE	5.5	450
9078A65G40	8CLE-GDM-E	9078A65G40	—	CLE	8.3	350
9078A67G01	CLPT-NL	9078A67G01	—	CLPT	—	10
9078A67G02	CLE-NL-C	9078A67G02	—	CLE	—	25
9078A67G03	CLE-NL-D	9078A67G03	—	CLE	—	250
9078A67G04	CLE-NL-E	9078A67G04	—	CLE	—	450
9078A67G05	9078A67G05	9078A67G05	Special live parts for triple barrel 15CLE3 fuse	CLE	15.5	200
9078A67G12	25CLPT-NL	9078A67G12	—	CLPT	25.5	1
9078A67G15	CLE-NLC-E	9078A67G15	—	CLE	—	450
9078A67G16	CLPT-NLC	9078A67G16	—	CLE	—	25
9078A67G17	CLE-NLC-C	9078A67G17	—	CLE	—	25
9078A67G20	CLE-NLC-D	9078A67G20	—	CLE	—	250
9078A68G01	5CLPT-PNM-A	9078A68G01	—	CLPT	5.5	10
9078A68G02	8CLPT-PNM-A	9078A68G02	—	CLPT	8.3	1.5

Appendix 2—Superseded Style Number Index

Old 10 Digit Style Number	Current Eaton Catalog Number	Eaton 10 Digit Style Number	Description	Type	Voltage Rating kV Max.	Current Rating Amperes
9078A68G03	15CLPT-PNM-A	9078A68G03	—	CLPT	15.5	1.5
9078A68G04	15CLPT-HPNM-A	9078A68G04	—	CLPT	15.5	1.5
9078A68G05	25CLPT-HPNM-A	9078A68G05	—	CLPT	25.5	1
9078A68G06	5CLPT-PNM-A	9078A68G06	—	CLPT	—	—
9078A68G07	8CLPT-PNM-B	9078A68G07	—	CLPT	8.3	10
9078A68G08	15CLPT-PNM-B	9078A68G08	—	CLPT	15.5	10
9078A68G09	15CLPT-HPNM-B	9078A68G09	—	CLPT	15.5	10
9078A68G10	2CLE-PNM-C	9078A68G10	—	CLE	2.75	25
9078A68G11	5CLE-PNM-C	9078A68G11	—	CLE	5.5	25
9078A68G12	8CLE-PNM-C	9078A68G12	—	CLE	8.3	25
9078A68G13	15CLE-PNM-C	9078A68G13	—	CLE	15.5	25
9078A68G14	15CLE-HPNM-C	9078A68G14	—	CLE	15.5	25
9078A68G15	2CLE-PNM-D	9078A68G15	—	CLE	2.75	250
9078A68G16	5CLE-PNM-D	9078A68G16	—	CLE	5.5	250
9078A68G17	8CLE-PNM-D	9078A68G17	—	CLE	8.3	175
9078A68G18	15CLE-PNM-D	9078A68G18	—	CLE	15.5	150
9078A68G19	15CLE-HPNM-D	9078A68G19	—	CLE	15.5	150
9078A68G20	2CLE-PNM-E	9078A68G20	—	CLE	2.75	450
9078A68G21	5CLE-PNM-E	9078A68G21	—	CLE	5.5	450
9078A68G22	8CLE-PNM-E	9078A68G22	—	CLE	8.3	350
9078A68G23	15CLE-PNM-E	9078A68G23	—	CLE	15.5	300
9078A68G24	9078A68G24	9078A68G24	Special mounting for triple barrel 15CLE3 fuse	CLE	15.5	200
9078A68G25	5CLPT-GNM-A	9078A68G25	—	CLPT	5.5	10
9078A68G26	8CLPT-GNM-A	9078A68G26	—	CLPT	8.3	2
9078A68G27	15CLPT-GNM-A	9078A68G27	—	CLPT	15.5	2
9078A68G28	5CLPT-GNM-A	9078A68G28	—	—	—	—
9078A68G29	8CLPT-GNM-B	9078A68G29	—	CLPT	8.3	10
9078A68G30	15CLPT-GNM-B	9078A68G30	—	CLPT	15.5	10
9078A68G31	2CLE-GNM-C	9078A68G31	—	CLE	2.75	25
9078A68G32	5CLE-GNM-C	9078A68G32	—	CLE	5.5	25
9078A68G33	8CLE-GNM-C	9078A68G33	—	CLE	8.3	25
9078A68G34	15CLE-GNM-C	9078A68G34	—	CLE	15.5	25
9078A68G35	2CLE-GNM-D	9078A68G35	—	CLE	2.75	250
9078A68G36	5CLE-GNM-D	9078A68G36	—	CLE	5.5	250
9078A68G37	8CLE-GNM-D	9078A68G37	—	CLE	8.3	175
9078A68G38	15CLE-GNM-D	9078A68G38	—	CLE	15.5	150
9078A68G39	2CLE-GNM-E	9078A68G39	—	CLE	2.75	450
9078A68G40	5CLE-GNM-E	9078A68G40	—	CLE	5.5	450
9078A68G41	8CLE-GNM-E	9078A68G41	—	CLE	8.3	350
9078A68G42	25CLPT-PNM	9078A68G42	—	CLPT	25.5	1
9078A69G01	2CLE-PDM-D	9078A69G01	—	CLE	2.75	250
9078A69G02	5CLE-PDM-D	9078A69G02	—	CLE	5.5	250
9078A69G03	5CLS-HPDM-D	9078A69G03	—	CLS	5.08	230
9078A69G04	9078A69G04	9078A69G04	Heavy duty hinge and contacts	CLE	2.75	250
9078A69G05	9078A69G05	9078A69G05	Heavy duty hinge and contacts	CLE	5.5	250
9078A69G06	9078A69G06	9078A69G06	Heavy duty hinge and contacts	CLS	5.08	230
9078A69G07	2CLE-PDM-E	9078A69G07	—	CLE	2.75	450
9078A69G08	5CLE-PDM-E	9078A69G08	—	CLE	5.5	450
9078A69G09	5CLS-HPDM-E	9078A69G09	—	CLS	5.08	480
9078A69G10	2CLE-GDM-D	9078A69G10	—	CLE	2.75	250
9078A69G11	5CLE-GDM-D	9078A69G11	—	CLE	5.5	250
9078A69G12	5CLS-HGDM-D	9078A69G12	—	CLS	5.08	230
9078A69G13	9078A69G13	9078A69G13	Heavy duty hinge and contacts	CLE	2.75	250

Appendix 2—Superseded Style Number Index

Old 10 Digit Style Number	Current Eaton Catalog Number	Eaton 10 Digit Style Number	Description	Type	Voltage Rating kV Max.	Current Rating Amperes
9078A69G14	9078A69G14	9078A69G14	Heavy duty hinge and contacts	CLE	5.5	250
9078A69G15	9078A69G15	9078A69G15	Heavy duty hinge and contacts	CLS	5.08	230
9078A69G16	2CLE-GDM-E	9078A69G16	—	CLE	2.75	450
9078A69G17	5CLE-GDM-E	9078A69G17	—	CLE	5.5	450
9078A69G18	5CLS-HGDM-E	9078A69G18	—	CLS	5.08	480
9078A70G01	Obsolete—contact Eaton	—	Glass polyester insulator mounting for CLE-750E	—	—	—
9078A70G02	Obsolete—contact Eaton	—	Porcelain insulator mounting for CLE-750E	—	—	—
9570D04G01	Obsolete—contact Eaton	—	8CLTX-15K—comb. fuse and term.	—	—	—
9570D04G02	Obsolete—contact Eaton	—	8CLTX-15K—comb. fuse and term.	—	—	—
9570D04G03	Obsolete—contact Eaton	—	8CLTX-25K—comb. fuse and term.	—	—	—
9570D04G04	Obsolete—contact Eaton	—	8CLTX-25K—comb. fuse and term.	—	—	—
9570D04G05	Obsolete—contact Eaton	—	8CLTX-40K—comb. fuse and term.	—	—	—
9570D04G06	Obsolete—contact Eaton	—	8CLTX-40K—comb. fuse and term.	—	—	—
9570D04G11	Obsolete—contact Eaton	—	8CLTX-15K—comb. fuse and term.	—	—	—
9570D04G12	Obsolete—contact Eaton	—	8CLTX-15K—comb. fuse and term.	—	—	—
9570D04G16	Obsolete—contact Eaton	—	8CLTX-25K—comb. fuse and term.	—	—	—
9570D04G17	Obsolete—contact Eaton	—	8CLTX-25K—comb. fuse and term.	—	—	—
9570D04G21	Obsolete—contact Eaton	—	8CLTX-40K—comb. fuse and term.	—	—	—
9570D04G22	Obsolete—contact Eaton	—	8CLTX-40K—comb. fuse and term.	—	—	—
9570D04G36	Obsolete—contact Eaton	—	15CLTX-15K—comb. fuse and term.	—	—	—
9570D04G37	Obsolete—contact Eaton	—	15CLTX-15K—comb. fuse and term.	—	—	—
9570D04G38	Obsolete—contact Eaton	—	15CLTX-25K—comb. fuse and term.	—	—	—
9570D04G39	Obsolete—contact Eaton	—	15CLTX-25K—comb. fuse and term.	—	—	—
9570D04G40	Obsolete—contact Eaton	—	15CLTX-40K—comb. fuse and term.	—	—	—
9570D04G41	Obsolete—contact Eaton	—	15CLTX-40K—comb. fuse and term.	—	—	—
9570D04G51	Obsolete—contact Eaton	—	15CLTX-15K—comb. fuse and term.	—	—	—
9570D04G52	Obsolete—contact Eaton	—	15CLTX-15K—comb. fuse and term.	—	—	—
9570D04G56	Obsolete—contact Eaton	—	15CLTX-25K—comb. fuse and term.	—	—	—
9570D04G57	Obsolete—contact Eaton	—	15CLTX-25K—comb. fuse and term.	—	—	—
9570D04G61	Obsolete—contact Eaton	—	15CLTX-40K—comb. fuse and term.	—	—	—
9570D04G62	Obsolete—contact Eaton	—	15CLTX-40K—comb. fuse and term.	—	—	—
9570D04G76	Obsolete—contact Eaton	—	23CLTX-15K—comb. fuse and term.	—	—	—
9570D04G77	Obsolete—contact Eaton	—	23CLTX-15K—comb. fuse and term.	—	—	—
9570D04G83	Obsolete—contact Eaton	—	23CLTX-15K—comb. fuse and term.	—	—	—
9570D04G84	Obsolete—contact Eaton	—	23CLTX-15K—comb. fuse and term.	—	—	—
9570D05G02	15CXN-GNM-G	9570D05G02	—	CXN	15.5	—
9570D05G06	15CXN-NL-G	9570D05G06	—	CXN	15.5	—
9570D06G01	15CXN-GDM-G	9570D06G01	—	CXN	15.5	—
9570D06G03	15CXN-DL-G	9570D06G03	—	CXN	15.5	—
9570D06G05	15CXN-DF-G	9570D06G05	—	CXN	15.5	—
9570D10G01	15CLT-30	9570D10G01	—	CLT	15.5	30
9570D33G01	15CXN-GNM-F	9570D33G01	—	CXN	15.5	—
9570D33G02	15CXN-NL-F	9570D33G02	—	CXN	15.5	—
9570D33G03	15CXN-GNM-D	9570D33G03	—	CXN	15.5	—
9570D33G04	5CXN-NL-D	9570D33G04	—	CXN	15.5	—
9570D34G01	15CXN-GDM-F	9570D34G01	—	CXN	15.5	—
9570D34G02	15CXN-DL-F	9570D34G02	—	CXN	15.5	—
9570D56G01	Obsolete—contact Eaton	—	8CLTX-15K—spade-to-spade	—	—	—
9570D56G02	Obsolete—contact Eaton	—	8CLTX-15K—spade-to-stud	—	—	—
9570D56G03	Obsolete—contact Eaton	—	8CLTX-40K—spade-to-spade	—	—	—
9570D56G04	Obsolete—contact Eaton	—	8CLTX-40K—spade-to-stud	—	—	—
9570D56G05	Obsolete—contact Eaton	—	8CLTX-25K—spade-to-spade	—	—	—
9570D56G06	Obsolete—contact Eaton	—	8CLTX-25K—spade-to-stud	—	—	—

Appendix 2—Superseded Style Number Index

Old 10 Digit Style Number	Current Eaton Catalog Number	Eaton 10 Digit Style Number	Description	Type	Voltage Rating kV Max.	Current Rating Amperes
9570D56G09	Obsolete—contact Eaton	—	15CLTX-15K—spade-to-spade	—	—	—
9570D56G10	Obsolete—contact Eaton	—	15CLTX-15K—spade-to-stud	—	—	—
9570D56G11	Obsolete—contact Eaton	—	15CLTX-25K—spade-to-spade	—	—	—
9570D56G12	Obsolete—contact Eaton	—	15CLTX-25K—spade-to-stud	—	—	—
9570D56G13	Obsolete—contact Eaton	—	15CLTX-40K—spade-to-spade	—	—	—
9570D56G14	Obsolete—contact Eaton	—	15CLTX-40K—spade-to-stud	—	—	—
9570D56G15	Obsolete—contact Eaton	—	23CLTX-15K—spade-to-spade	—	—	—
9570D56G16	Obsolete—contact Eaton	—	23CLTX-15K—spade-to-stud	—	—	—
9570D64G01	5BCLS-32R	9570D64G01	—	—	—	—
9570D64G02	5BCLS-36R	9570D64G02	—	—	—	—
9570D64G03	5BCLS-44R	9570D64G03	—	—	—	—
9570D64G04	5BCLS-600E	9570D64G04	—	—	—	—
9570D64G05	5BCLS-750E	9570D64G05	—	—	—	—
9570D69G01	7BCLS-44R	9570D69G01	—	—	—	—

Appendix 3—Catalog Number/Style Number Cross Reference

Cross Reference

Catalog Number—Style Number Cross Reference

Catalog Number	Style Number	Catalog Number	Style Number	Catalog Number	Style Number	Catalog Number	Style Number
121DBA2-100E	11A8127G53	14RBA8-GNM	9078A33G24	15BHLE-175E	5984C05G13	15CLE-PDM-D	9078A65G18
121DBA2-10E	11A8127G44	14RBA8-GNM	9078A33G24	15BHLE-200E	5984C05G14	15CLE-PDM-E	9078A65G23
121DBA2-125E	11A8127G54	14RBA8-PNM	9078A33G13	15BHLE-20E	5984C05G03	15CLE-PNM-C	9078A68G13
121DBA2-150E	11A8127G55	14RBA8-PNM	9078A33G13	15BHLE2-100E	5984C05G20	15CLE-PNM-D	9078A68G18
121DBA2-15E	11A8127G45	14RBA8-PNM	9078A33G13	15BHLE2-125E	5984C05G21	15CLE-PNM-E	9078A68G23
121DBA2-200E	11A8127G56	151D257G03	151D257G03	15BHLE2-40E	5984C05G16	15CLT-12C	678C295G02
121DBA2-20E	11A8127G46	151D257G04	151D257G04	15BHLE-250E	5984C05G15	15CLT-18C	678C295G07
121DBA2-25E	11A8127G47	15BA2-.5	117D123A17	15BHLE2-50E	5984C05G17	15CLT-30C	9570D10G01
121DBA2-3	11A8127G41	15BA2-100E	117D123A29	15BHLE-25E	5984C05G04	15CLT-4C	678C295G05
121DBA2-30E	11A8127G48	15BA2-10E	117D123A20	15BHLE2-65E	5984C05G18	15CLT-5C	678C295G04
121DBA2-40E	11A8127G49	15BA2-125E	117D123A30	15BHLE2-80E	5984C05G19	15CLT-8C	678C295G03
121DBA2-50E	11A8127G50	15BA2-150E	117D123A31	15BHLE-30E	5984C05G05	15CX-10C	151D883G11
121DBA2-5E	11A8127G42	15BA2-15E	117D123A21	15BHLE-40E	5984C05G06	15CX-12C	5980C19G07
121DBA2-65E	11A8127G51	15BA2-200E	117D123A32	15BHLE-50E	5984C05G07	15CX-15C	151D883G05
121DBA2-780E	11A8127G52	15BA2-20E	117D123A22	15BHLE-65E	5984C05G08	15CX-18C	5980C19G01
121DBA2-7E	11A8127G43	15BA2-25E	117D123A23	15BHLE-80E	5984C05G09	15CX-20C	5980C19G02
145DBA2-100E	11A8127G73	15BA2-30E	117D123A24	15CLE-100E	5981C19G08	15CX-25C	5980C19G03
145DBA2-10E	11A8127G64	15BA2-40E	117D123A25	15CLE-10E	5981C33G01	15CX-30C	5980C19G04
145DBA2-125E	11A8127G74	15BA2-50E	117D123A26	15CLE-125E	5981C19G09	15CX-3C	151D883G12
145DBA2-150E	11A8127G75	15BA2-5E	117D123A18	15CLE-150E	5981C19G10	15CX-40C	5980C19G05
145DBA2-15E	11A8127G65	15BA2-65E	117D123A27	15CLE-15E	678C240G10	15CX-4C	151D883G01
145DBA2-200E	11A8127G76	15BA2-7E	117D123A19	15CLE-15E-D	5981C33G02	15CX-6C	5980C19G06
145DBA2-20E	11A8127G66	15BA2-80E	117D123A28	15CLE-175E	5981C25G01	15CX-7C	151D883G02
145DBA2-25E	11A8127G67	15BA2-NH	310C198G02	15CLE-200E	5981C25G02	15CX-8C	5980C19G07
145DBA2-3	11A8127G61	15BA4-.5	116D977A21	15CLE-20E	678C240G11	15CX-GDM-G	151D885G03
145DBA2-30E	11A8127G68	15BA4-100E	116D977A33	15CLE-20E-D	5981C33G03	15CX-GNM-G	151D884G03
145DBA2-40E	11A8127G69	15BA4-10E	116D977A24	15CLE2-100E	439D482G05	15CXI-10C	151D883G31
145DBA2-50E	11A8127G70	15BA4-125E	116D977A34	15CLE2-125X	439D482G06	15CXI-12C	5980C19G27
145DBA2-5E	11A8127G62	15BA4-150E	116D977A35	15CLE-250E	5981C25G03	15CXI-15C	151D883G25
145DBA2-65E	11A8127G71	15BA4-15E	116D977A25	15CLE-25E	678C240G12	15CXI-18C	5980C19G21
145DBA2-780E	11A8127G72	15BA4-200E	116D977A36	15CLE-25E-D	5981C33G04	15CXI-20C	5980C19G22
145DBA2-7E	11A8127G63	15BA4-20E	116D977A26	15CLE2-80E	439D482G04	15CXI-25C	5980C19G23
14RBA2-GDM	9078A25G04	15BA4-250E	116D977A37	15CLE-300E	5981C25G04	15CXI-30C	5980C19G24
14RBA2-GDM	9078A25G04	15BA4-25E	116D977A27	15CLE-30E	5981C33G05	15CXI-3C	151D883g32
14RBA2-GNM	9078A33G18	15BA4-300E	116D977A38	15CLE3-150E	591C376G02	15CXI-40C	5980C19G25
14RBA2-GNM	9078A33G18	15BA4-30E	116D977A28	15CLE3-175E/200X	591C376G01	15CXI-4C	151D883G21
14RBA2-PDM	9078A25G03	15BA4-400E	116D977A39	15CLE-40E	5981C19G04	15CXI-6C	5980C19G26
14RBA2-PDM	9078A25G03	15BA4-40E	116D977A29	15CLE-50E	5981C19G05	15CXI-7C	151D883G22
14RBA2-PNM	9078A33G03	15BA4-50E	116D977A30	15CLE-65E	5981C19G06	15CXI-8C	5980C19G27
14RBA2-PNM	9078A33G03	15BA4-5E	116D977A22	15CLE-80E	5981C19G07	15CXN-100C	9570D02G06
14RBA4-GDM	9078A19G04	15BA4-65E	116D977A31	15CLE-GDM-C	9078A65G33	15CXN-45C	9570D02G02
14RBA4-GDM	9078A19G04	15BA4-7E	116D977A23	15CLE-GDM-D	9078A65G37	15CXN-60C	9570D02G03
14RBA4-GNM	9078A33G21	15BA4-80E	116D977A32	15CLE-GNM-C	9078A68G34	15CXN-75C	9570D02G04
14RBA4-GNM	9078A33G21	15BA4-NH	310C196G02	15CLE-GNM-D	9078A68G38	15CXN-85C	9570D02G05
14RBA4-PDM	9078A19G03	15BHLE-100E	5984C05G10	15CLE-HPDM-C	9078A65G14	15CXN-DF-G	9570D06G05
14RBA4-PDM	9078A19G03	15BHLE-10E	5984C05G01	15CLE-HPDM-D	9078A65G19	15CXN-DL-F	9570D34G02
14RBA4-PNM	9078A33G08	15BHLE-125E	5984C05G11	15CLE-HPNM-C	9078A68G14	15CXN-DL-G	9570D06G03
14RBA4-PNM	9078A33G08	15BHLE-150E	5984C05G12	15CLE-HPNM-D	9078A68G19	15CXN-GDM-F	9570D34G01
14RBA8-GNM	9078A33G24	15BHLE-15E	5984C05G02	15CLE-PDM-C	9078A65G13	15CXN-GDM-G	9570D06G01

Appendix 3—Catalog Number/Style Number Cross Reference

Catalog Number	Style Number	Catalog Number	Style Number	Catalog Number	Style Number	Catalog Number	Style Number
15CXN-GNM-D	9570D33G03	15HLE-GDM-D	5981C03G06	15RBA2-INH-B	5981C18G02	15RBA4-INH-B	5981C17G02
15CXN-GNM-F	9570D33G01	15HLE-GDM-E	5981C03G18	15RBA2-INH-B	5981C18G02	15RBA4-ISHNT	678C283G06
15CXN-GNM-G	9570D05G02	15HLE-GNM-D	5981C03G12	15RBA2-ISHNT	309C548G10	15RBA4-ISHNT	678C283G06
15CXN-NL-D	9570D33G04	15HLE-GNM-E	5981C03G24	15RBA2-NH	677C370G02	15RBA4-NH	677C371G02
15CXN-NL-F	9570D33G02	15HLE-PDM-D	5981C03G03	15RBA2-NH	677C370G02	15RBA4-NH	677C371G02
15CXN-NL-G	9570D05G06	15HLE-PDM-E	5981C03G15	15RBA2-NL	9078A30A01	15RBA4-NL	9078A30A03
15DBA1-0.5	5980C15G21	15HLE-PNM-D	5981C03G09	15RBA2-NL	9078A30A01	15RBA4-NL	9078A30A03
15DBA1-100E	5980C15G34	15HLE-PNM-E	5981C03G21	15RBA2-NL	9078A30A01	15RBA4-NL	9078A30A03
15DBA1-10E	5980C15G25	15LHLE-100E	5984C65G03	15RBA2-NL	9078A30A01	15RBA4-NL	9078A30A03
15DBA1-125E	5980C15G35	15LHLE-125E	5984C65G08	15RBA2-NL	9078A30A01	15RBA4-NL	9078A30A03
15DBA1-150E	5980C15G36	15LHLE-150E	5984C65G09	15RBA2-NL	9078A30A01	15RBA4-NL	9078A30A03
15DBA1-15E	5980C15G26	15LHLE-175E	5984C65G06	15RBA2-NL	9078A30A01	15RBA4-NL	9078A30A03
15DBA1-200E	5980C15G37	15LHLE-200E	5984C65G07	15RBA2-NL	9078A30A01	15RBA4-NL	9078A30A03
15DBA1-20E	5980C15G27	15LHLE2-125E	5984C65G04	15RBA2-PDM	9078A25G05	15RBA4-PDM	9078A19G05
15DBA1-25E	5980C15G28	15LHLE2-150E	5984C65G05	15RBA2-PDM	9078A25G05	15RBA4-PDM	9078A19G05
15DBA1-3	5980C15G22	15LHLE-250E	5984C65G10	15RBA2-PNM	9078A33G25	15RBA4-PNM	9078A33G26
15DBA1-30E	5980C15G29	15LHLE-300E	5984C65G11	15RBA2-PNM	9078A33G25	15RBA4-PNM	9078A33G26
15DBA1-40E	5980C15G30	15LHLE-65E	5984C65G01	15RBA4-5	5982C44A26	15RBA8-INH	5981C54G02
15DBA1-50E	5980C15G31	15LHLE-80E	5984C65G02	15RBA4-100E	5982C44A39	15RBA8-INH	5981C54G02
15DBA1-5E	5980C15G23	15NCLPT-0.5E-A	5981C07G06	15RBA4-10E	5982C44A30	15RBA8-NL	9078A30A05
15DBA1-65E	5980C15G32	15NCLPT-10E-B	5981C07G01	15RBA4-125E	5982C44A40	15RBA8-NL	9078A30A05
15DBA1-7E	5980C15G24	15NCLPT-1E-A	5981C07G05	15RBA4-150E	5982C44A41	15RBA8-NL	9078A30A05
15DBA1-80E	5980C15G33	15NCLPT-20.5E-A	5981C07G04	15RBA4-15E	5982C44A31	15RBA8-NL	9078A30A05
15HCL-100E	5981C68G06	15NCLPT-3E-B	5981C07G03	15RBA4-175E	5982C44A42	15RBA8-NL	9078A30A05
15HCL-10E	5982C34G01	15NCLPT-5E-B	5981C07G02	15RBA4-200E	5982C44A43	15RBA8-NL	9078A30A05
15HCL-125E	5981C68G07	15RBA2-100E	423D814A34	15RBA4-20E	5982C44A32	15RBA8-NL	9078A30A05
15HCL-150E	5981C61G04	15RBA2-10E	423D814A25	15RBA4-250E	5982C44A44	15RBA8-NL	9078A30A05
15HCL-15E	5982C34G02	15RBA2-125E	423D814A35	15RBA4-25E	5982C44A33	15RBA8-NL	9078A30A05
15HCL-200E	5981C61G03	15RBA2-150E	423D814A36	15RBA4-3	5982C44A27	15RBA8-PNM	9078A33G27
15HCL-20E	5982C34G03	15RBA2-15E	423D814A26	15RBA4-300E	5982C44A45	15RBA8-PNM	9078A33G27
15HCL-250E	5981C61G01	15RBA2-175E	423D814A37	15RBA4-30E	5982C44A34	15RBA8-PNM	9078A33G27
15HCL-25E	5982C34G04	15RBA2-200E	423D814A38	15RBA4-400E	5982C44A47	15RBT2-100E	449D671A34
15HCL-300E	5981C61G02	15RBA2-20E	423D814A27	15RBA4-40E	5982C44A35	15RBT2-125E	449D671A35
15HCL-30E	5982C34G05	15RBA2-25E	423D814A28	15RBA4-50E	5982C44A36	15RBT2-150E	449D671A36
15HCL-40E	5982C34G06	15RBA2-30E	423D814A29	15RBA4-5E	5982C44A28	15RBT2-200E	449D671A38
15HCL-50E	5982C34G07	15RBA2-40E	423D814A30	15RBA4-65E	5982C44A37	15RBT2-20E	449D671A27
15HCL-65E	5981C68G04	15RBA2-50E	423D814A31	15RBA4-7E	5982C44A29	15RBT2-25E	449D671A28
15HCL-80E	5981C68G05	15RBA2-65E	423D814A32	15RBA4-80E	5982C44A38	15RBT2-30E	449D671A29
15HLE-100E	5981C18G09	15RBA2-80E	423D814A33	15RBA4-DH	309C797G02	15RBT2-40E	449D671A30
15HLE-10E	5981C32G01	15RBA2-DH	309C558G02	15RBA4-DH	309C797G02	15RBT2-50E	449D671A31
15HLE-125E	5981C18G10	15RBA2-DH	309C558G02	15RBA4-DL	9078A20A01	15RBT2-65E	449D671A32
15HLE-150E	5981C24G01	15RBA2-DL	9078A26A01	15RBA4-DL	9078A20A01	15RBT2-80E	449D671A33
15HLE-15E	5981C32G02	15RBA2-DL	9078A26A01	15RBA4-DL	9078A20A01	15RBT4-100E	5982C49A39
15HLE-175E	5981C24G02	15RBA2-DL	9078A26A01	15RBA4-DL	9078A20A01	15RBT4-125E	5982C49A40
15HLE-200E	5981C24G03	15RBA2-DL	9078A26A01	15RBA4-DL	9078A20A01	15RBT4-150E	5982C49A41
15HLE-20E	5981C32G03	15RBA2-DL	9078A26A01	15RBA4-DL	9078A20A01	15RBT4-200E	5982C49A43
15HLE-250E	5981C24G04	15RBA2-DL	9078A26A01	15RBA4-DL	9078A20A01	15RBT4-20E	5982C49A32
15HLE-25E	5981C32G04	15RBA2-DL	9078A26A01	15RBA4-DL	9078A20A01	15RBT4-250E	5982C49A44
15HLE-30E	5981C32G05	15RBA2-DL	9078A26A01	15RBA4-IDH	5981C52G02	15RBT4-25E	5982C49A33
15HLE-40E	5981C18G05	15RBA2-IDH	5981C50G02	15RBA4-IDH	5981C52G02	15RBT4-300E	5982C49A45
15HLE-50E	5981C18G06	15RBA2-IDH	5981C50G02	15RBA4-INH	5981C53G02	15RBT4-30E	5982C49A34
15HLE-65E	5981C18G07	15RBA2-INH	5981C51G02	15RBA4-INH	5981C53G02	15RBT4-400E	5982C49A47
15HLE-80E	5981C18G08	15RBA2-INH	5981C51G02	15RBA4-INH-B	5981C17G02	15RBT4-40E	5982C49A35

Appendix 3—Catalog Number/Style Number Cross Reference

Catalog Number	Style Number	Catalog Number	Style Number	Catalog Number	Style Number	Catalog Number	Style Number
15RBT4-50E	5982C49A36	25BA4-40E	116D977A49	25RBA4-175E	5982C44A67	25RDB2-DH	309C558G07
15RBT4-65E	5982C49A37	25BA4-50E	116D977A50	25RBA4-200E	5982C44A68	25RDB2-DH	309C558G07
15RBT4-80E	5982C49A38	25BA4-5E	116D977A42	25RBA4-20E	5982C44A57	25RDB2-HUM	140D349G18
15RDB2-DH	309C558G06	25BA4-65E	116D977A51	25RBA4-250E	5982C44A69	25RDB2-HVM	140D340G18
15RDB2-DH	309C558G06	25BA4-7E	116D977A43	25RBA4-25E	5982C44A58	25RDB2-SHNT	308C548G03
15RDB2-HUM	140D349G17	25BA4-80E	116D977A52	25RBA4-3	5982C44A52	25RDB2-VM	140D340G13
15RDB2-HVM	140D340G17	25DBA1-0.5	5980C16G01	25RBA4-300E	5982C44A70	25RDB4-DH	310C131G03
15RDB2-SHNT	308C548G02	25DBA1-100E	5980C16G14	25RBA4-30E	5982C44A59	25RDB4-DH	310C131G03
15RDB2-UM	140D349G12	25DBA1-10E	5980C16G05	25RBA4-40E	5982C44A60	25RDB4-DH	310C131G03
15RDB2-UM	140D349G13	25DBA1-125E	5980C16G15	25RBA4-50E	5982C44A61	25RDB4-HUM	140D346G18
15RDB2-VM	140D340G12	25DBA1-150E	5980C16G16	25RBA4-5E	5982C44A53	25RDB4-HVM	140D341G18
15RDB4-DH	310C131G02	25DBA1-15E	5980C16G06	25RBA4-65E	5982C44A62	25RDB4-SHNT	678C284G03
15RDB4-DH	310C131G02	25DBA1-200E	5980C16G17	25RBA4-7E	5982C44A54	25RDB4-SHNT	678C284G03
15RDB4-DH	310C131G02	25DBA1-20E	5980C16G07	25RBA4-80E	5982C44A63	25RDB4-UM	140D346G13
15RDB4-DH	310C131G02	25DBA1-25E	5980C16G08	25RBA4-DH	309C797G03	25RDB4-VM	140D341G13
15RDB4-HUM	140D346G17	25DBA1-3	5980C16G02	25RBA4-IDH	5981C52G03	25RDB8-HUM	140D354G18
15RDB4-HVM	140D341G17	25DBA1-30E	5980C16G09	25RBA4-INH	5981C53G03	25RDB8-HVM	140D342G18
15RDB4-SHNT	678C284G02	25DBA1-40E	5980C16G10	25RBA4-INH-B	5981C17G03	25RDB8-UM	140D354G13
15RDB4-SHNT	678C284G02	25DBA1-50E	5980C16G11	25RBA4-ISHNT	678C283G07	25RDB8-VM	140D342G13
15RDB4-UM	140D346G12	25DBA1-5E	5980C16G03	25RBA4-ISHNT	678C283G07	2ACL5-12R	591C142G08
15RDB4-VM	140D341G12	25DBA1-65E	5980C16G12	25RBA4-NH	677C371G03	2ACL5-18R	591C143G01
15RDB8-HUM	140D354G17	25DBA1-7E	5980C16G04	25RBA4-PDM	9078A19G06	2ACL5-24R	591C143G02
15RDB8-HVM	140D342G17	25DBA1-80E	5980C16G13	25RBA4-PDM	9078A19G06	2ACL5-25	591C142G01
15RDB8-UM	140D354G12	25RBA2-100E	423D814A54	25RBA4-PNM	9078A33G09	2ACL5-2R	591C142G02
15RDB8-VM	140D342G12	25RBA2-10E	423D814A45	25RBA4-PNM	9078A33G09	2ACL5-3R	591C142G03
25BA2-.5	117D123A33	25RBA2-125E	423D814A55	25RBA8-INH	5981C54G03	2ACL5-4R	591C142G04
25BA2-100E	117D123A45	25RBA2-150E	423D814A56	25RBA8-PNM	9078A33G27	2ACL5-5R	591C142G05
25BA2-10E	117D123A36	25RBA2-15E	423D814A46	25RBA8-PNM	9078A33G27	2ACL5-6R	591C142G06
25BA2-125E	117D123A46	25RBA2-175E	423D814A57	25RBT2-100E	449D671A54	2ACL5-9R	591C142G07
25BA2-150E	117D123A47	25RBA2-200E	423D814A58	25RBT2-125E	449D671A55	2BCL5-12R	5982C47G08
25BA2-15E	117D123A37	25RBA2-20E	423D814A47	25RBT2-150E	449D671A56	2BCL5-18R	5982C47G09
25BA2-200E	117D123A48	25RBA2-25E	423D814A48	25RBT2-200E	449D671A58	2BCL5-24R	5982C47G10
25BA2-20E	117D123A38	25RBA2-30E	423D814A49	25RBT2-20E	449D671A47	2BCL5-25	5982C47G01
25BA2-25E	117D123A39	25RBA2-40E	423D814A50	25RBT2-25E	449D671A48	2BCL5-2R	5982C47G02
25BA2-30E	117D123A40	25RBA2-50E	423D814A51	25RBT2-30E	449D671A49	2BCL5-3R	5982C47G03
25BA2-40E	117D123A41	25RBA2-65E	423D814A52	25RBT2-40E	449D671A50	2BCL5-4R	5982C47G04
25BA2-50E	117D123A42	25RBA2-80E	423D814A53	25RBT2-50E	449D671A51	2BCL5-5R	5982C47G05
25BA2-5E	117D123A34	25RBA2-DH	309C558G03	25RBT2-65E	449D671A52	2BCL5-6R	5982C47G06
25BA2-65E	117D123A43	25RBA2-IDH	5981C50G03	25RBT2-80E	449D671A53	2BCL5-9R	5982C47G07
25BA2-7E	117D123A35	25RBA2-INH	5981C51G03	25RBT4-100E	5982C49A64	2CLE-100E	449D797G06
25BA2-80E	117D123A44	25RBA2-INH-B	5981C18G03	25RBT4-125E	5982C49A65	2CLE-10E	449D797G11
25BA4-.5	116D977A41	25RBA2-ISHNT	309C548G11	25RBT4-150E	5982C49A66	2CLE-125E	449D797G07
25BA4-100E	116D977A53	25RBA2-NH	676C880G03	25RBT4-200E	5982C49A68	2CLE-150E	449D797G08
25BA4-10E	116D977A44	25RBA2-PDM	9078A25G06	25RBT4-20E	5982C49A57	2CLE-15E	678C240G01
25BA4-125E	116D977A54	25RBA2-PDM	9078A25G06	25RBT4-250E	5982C49A69	2CLE-200E	449D797G09
25BA4-150E	116D977A55	25RBA2-PNM	9078A33G04	25RBT4-25E	5982C49A58	2CLE-20E	678C240G02
25BA4-15E	116D977A45	25RBA2-PNM	9078A33G04	25RBT4-300E	5982C49A70	2CLE-225E	449D797G10
25BA4-200E	116D977A56	25RBA4-.5	5982C44A51	25RBT4-30E	5982C49A59	2CLE-250E	449D797G13
25BA4-20E	116D977A46	25RBA4-100E	5982C44A64	25RBT4-40E	5982C49A60	2CLE-25E	678C240G03
25BA4-250E	116D977A57	25RBA4-10E	5982C44A55	25RBT4-50E	5982C49A61	2CLE-25E	449D797G12
25BA4-25E	116D977A47	25RBA4-125E	5982C44A65	25RBT4-65E	5982C49A62	2CLE-300E	449D797G14
25BA4-300E	116D977A58	25RBA4-150E	5982C44A66	25RBT4-80E	5982C49A63	2CLE-30E	449D797G02
25BA4-30E	116D977A48	25RBA4-15E	5982C44A56				

Appendix 3—Catalog Number/Style Number Cross Reference

Catalog Number	Style Number	Catalog Number	Style Number	Catalog Number	Style Number	Catalog Number	Style Number
2CLE-350X	449D797G15	38BA2-20E	117D123A54	38DBA2-3	505D420G07	38RBA4-30E	5982C44A84
2CLE-400X	449D797G17	38BA2-25E	117D123A55	38DBA2-30E	18A7330G19	38RBA4-40E	5982C44A85
2CLE-450X	449D797G18	38BA2-30E	117D123A56	38DBA2-40E	18A7330G20	38RBA4-50E	5982C44A86
2CLE-50E	449D797G03	38BA2-40E	117D123A57	38DBA2-50E	18A7330G21	38RBA4-5E	5982C44A78
2CLE-65E	449D797G04	38BA2-50E	117D123A58	38DBA2-5E	18A7330G13	38RBA4-65E	5982C44A87
2CLE-80E	449D797G05	38BA2-5E	117D123A50	38DBA2-65E	18A7330G22	38RBA4-7E	5982C44A79
2CLE-GDM-C	9078A65G30	38BA2-65E	117D123A59	38DBA2-780E	18A7330G23	38RBA4-80E	5982C44A88
2CLE-GDM-D	9078A65G34	38BA2-7E	117D123A51	38DBA2-7E	18A7330G14	38RBA4-DH	309C797G04
2CLE-GDM-E	9078A65G38	38BA2-80E	117D123A60	38RBA2-100E	423D814A74	38RBA4-DL	9078A20A02
2CLE-GNM-C	9078A68G31	38BA4-.5	116D977A61	38RBA2-10E	423D814A65	38RBA4-IDH	5981C52G04
2CLE-GNM-D	9078A68G35	38BA4-100E	116D977A73	38RBA2-125E	423D814A75	38RBA4-INH	5981C53G04
2CLE-GNM-E	9078A68G39	38BA4-10E	116D977A64	38RBA2-150E	423D814A76	38RBA4-INH-B	5981C17G04
2CLE-PDM-C	9078A65G10	38BA4-125E	116D977A74	38RBA2-15E	423D814A66	38RBA4-ISHNT	678C283G08
2CLE-PDM-D	9078A65G15	38BA4-150E	116D977A75	38RBA2-175E	423D814A77	38RBA4-ISHNT	678C283G08
2CLE-PDM-E	9078A65G20	38BA4-15E	116D977A65	38RBA2-200E	423D814A78	38RBA4-NH	677C371G04
2CLE-PNM-C	9078A68G10	38BA4-200E	116D977A76	38RBA2-20E	423D814A67	38RBA4-NL	9078A30A04
2CLE-PNM-D	9078A68G15	38BA4-20E	116D977A66	38RBA2-25E	423D814A68	38RBA4-NL	9078A30A04
2CLE-PNM-E	9078A68G20	38BA4-250E	116D977A77	38RBA2-30E	423D814A69	38RBA4-PDM	9078A19G07
2CLS-12R	591C812G08	38BA4-25E	116D977A67	38RBA2-40E	423D814A70	38RBA4-PDM	9078A19G07
2CLS-18R	591C813G01	38BA4-300E	116D977A78	38RBA2-50E	423D814A71	38RBA4-PNM	9078A33G10
2CLS-24R	591C813G02	38BA4-30E	116D977A68	38RBA2-65E	423D814A72	38RBA4-PNM	9078A33G10
2CLS-25	591C812G01	38BA4-40E	116D977A69	38RBA2-80E	423D814A73	38RBA8-INH	5981C54G04
2CLS-2R	591C812G02	38BA4-50E	116D977A70	38RBA2-DH	309C558G04	38RBA8-NL	9078A30A06
2CLS-3R	591C812G03	38BA4-5E	116D977A62	38RBA2-DL	9078A26A02	38RBA8-NL	9078A30A06
2CLS-4R	591C812G04	38BA4-65E	116D977A71	38RBA2-DL	9078A26A02	38RBA8-NL	9078A30A06
2CLS-5R	591C812G05	38BA4-7E	116D977A63	38RBA2-DL	9078A26A02	38RBA8-PNM	9078A33G15
2CLS-6R	591C812G06	38BA4-80E	116D977A72	38RBA2-DL	9078A26A02	38RBA8-PNM	9078A33G15
2CLS-9R	591C812G07	38DBA1-0.5	5980C16G21	38RBA2-IDH	5981C50G04	38RBA8-PNM	9078A33G15
2CLT-12C	678C249G01	38DBA1-100E	5980C16G34	38RBA2-INH	5981C51G04	38RBT2-100E	449D671A74
2CLT-150C	680C387G01	38DBA1-10E	5980C16G25	38RBA2-INH-B	5981C18G04	38RBT2-125E	449D671A75
2CLT-18C	678C276G01	38DBA1-125E	5980C16G35	38RBA2-ISHNT	309C548G12	38RBT2-150E	449D671A76
2CLT-25C	678C276G04	38DBA1-150E	5980C16G36	38RBA2-NH	677C370G04	38RBT2-200E	449D671A78
2CLT-30C	678C277G04	38DBA1-15E	5980C16G26	38RBA2-NL	9078A30A02	38RBT2-20E	449D671A67
2CLT-5C	678C248G01	38DBA1-200E	5980C16G37	38RBA2-NL	9078A30A02	38RBT2-25E	449D671A68
2CLT-75C	678C282G01	38DBA1-20E	5980C16G27	38RBA2-NL	9078A30A02	38RBT2-30E	449D671A69
2CLT-90C	680C387G02	38DBA1-25E	5980C16G28	38RBA2-NL	9078A30A02	38RBT2-40E	449D671A70
2HCLS-12R	591C155G08	38DBA1-3	5980C16G22	38RBA2-PDM	9078A25G07	38RBT2-50E	449D671A71
2HCLS-18R	591C157G01	38DBA1-30E	5980C16G29	38RBA2-PDM	9078A25G07	38RBT2-65E	449D671A72
2HCLS-24R	591C157G02	38DBA1-40E	5980C16G30	38RBA2-PNM	9078A33G05	38RBT2-80E	449D671A73
2HCLS-25	591C155G01	38DBA1-50E	5980C16G31	38RBA2-PNM	9078A33G05	38RBT4-100E	5982C49A89
2HCLS-2R	591C155G02	38DBA1-5E	5980C16G23	38RBA4-.5	5982C44A76	38RBT4-125E	5982C49A90
2HCLS-3R	591C155G03	38DBA1-65E	5980C16G32	38RBA4-100E	5982C44A89	38RBT4-150E	5982C49A91
2HCLS-4R	591C155G04	38DBA1-7E	5980C16G24	38RBA4-10E	5982C44A80	38RBT4-200E	5982C49A93
2HCLS-5R	591C155G05	38DBA1-80E	5980C16G33	38RBA4-125E	5982C44A90	38RBT4-20E	5982C49A82
2HCLS-6R	591C155G06	38DBA2-.5	22A6782G04	38RBA4-150E	5982C44A91	38RBT4-250E	5982C49A94
2HCLS-9R	591C155G07	38DBA2-100E	18A7330G24	38RBA4-15E	5982C44A81	38RBT4-25E	5982C49A83
38BA2-.5	117D123A49	38DBA2-10E	18A7330G15	38RBA4-175E	5982C44A92	38RBT4-300E	5982C49A95
38BA2-100E	117D123A61	38DBA2-125E	18A7330G25	38RBA4-200E	5982C44A93	38RBT4-30E	5982C49A84
38BA2-10E	117D123A52	38DBA2-150E	18A7330G26	38RBA4-20E	5982C44A82	38RBT4-40E	5982C49A85
38BA2-125E	117D123A62	38DBA2-15E	18A7330G16	38RBA4-250E	5982C44A94	38RBT4-50E	5982C49A86
38BA2-150E	117D123A63	38DBA2-200E	18A7330G27	38RBA4-25E	5982C44A83	38RBT4-65E	5982C49A87
38BA2-15E	117D123A53	38DBA2-20E	18A7330G17	38RBA4-3	5982C44A77	38RBT4-80E	5982C49A88
38BA2-200E	117D123A64	38DBA2-25E	18A7330G18	38RBA4-300E	5982C44A95	38RDB2-DH	309C558G08

Appendix 3—Catalog Number/Style Number Cross Reference

Catalog Number	Style Number	Catalog Number	Style Number	Catalog Number	Style Number	Catalog Number	Style Number
38RDB2-DH	309C558G08	48DBA2-7E	18A7330G34	5AHLE-350E	5981C46G17	5CLE-15E	678C240G04
38RDB2-HUM	140D349G19	4ACLS-26R	151D207G01	5AHLE-400E	5981C46G18	5CLE-15E-D	5981C29G02
38RDB2-HVM	140D340G19	4BCLS-26R	5982C32G03	5AHLE-40E	5981C46G06	5CLE-175E	5981C65G08
38RDB2-SHNT	308C548G04	4CX-100C	5978C66G05	5AHLE-450E	5981C46G19	5CLE-200E	5981C65G09
38RDB2-UM	140D349G14	4CX-18C	5978C62G01	5AHLE-50E	5981C46G07	5CLE-20E	678C240G05
38RDB2-VM	140D340G14	4CX-25C	5978C62G02	5AHLE-65E	5981C46G08	5CLE-20E-D	5981C29G03
38RDB4-DH	310C131G04	4CX-35C	5978C62G03	5AHLE-80E	5981C46G09	5CLE-250E	5981C65G10
38RDB4-DH	310C131G04	4CX-45C	5978C66G01	5BCLS-12R	5982C31G08	5CLE-25E	678C240G06
38RDB4-DH	310C131G04	4CX-50C	5978C66G02	5BCLS-18R	5982C32G01	5CLE-25E-D	5981C29G04
38RDB4-DH	310C131G04	4CX-60C	151D253G06	5BCLS-24R	5982C32G02	5CLE-300E	5981C67G01
38RDB4-HUM	140D346G19	4CX-65C	5978C66G03	5BCLS-2R	5982C31G02	5CLE-30E	5981C29G05
38RDB4-HVM	140D341G19	4CX-75C	5978C66G04	5BCLS-30	5982C31G01	5CLE-350E	5981C67G02
38RDB4-SHNT	678C284G04	4CX-80C	151D253G08	5BCLS-32R	9570D64G01	5CLE-400E	5981C67G03
38RDB4-SHNT	678C284G04	4CXI-100C	5978C66G25	5BCLS-36R	9570D64G02	5CLE-40E	5981C65G01
38RDB4-UM	140D346G14	4CXI-18C	5978C62G21	5BCLS-3R	5982C31G03	5CLE-450E	5981C67G04
38RDB4-VM	140D341G14	4CXI-25C	5978C62G22	5BCLS-44R	9570D64G03	5CLE-50E	5981C65G02
38RDB8-HUM	140D354G19	4CXI-35C	5978C62G23	5BCLS-4R	5982C31G04	5CLE-600E	449D595G02
38RDB8-HVM	140D342G19	4CXI-45C	5978C66G21	5BCLS-5R	5982C31G05	5CLE-65E	5981C65G03
38RDB8-UM	140D354G14	4CXI-50C	5978C66G22	5BCLS-600E	9570D64G04	5CLE-750E	449D595G01
38RDB8-VM	140D342G14	4CXI-60C	151D253G26	5BCLS-6R	5982C31G06	5CLE-80E	5981C65G04
48DBA1-0.5	5980C17G01	4CXI-65C	5978C66G23	5BCLS-750E	9570D64G05	5CLE-GDM-C	9078A65G31
48DBA1-100E	5980C17G14	4CXI-75C	5978C66G24	5BCLS-9R	5982C31G07	5CLE-GDM-D	9078A65G35
48DBA1-10E	5980C17G05	4CXI-80C	151D253G28	5BHCL-400E	5981C62G11	5CLE-GDM-E	9078A65G39
48DBA1-125E	5980C17G15	4NPL-1300	140D318G05	5BHCL-450E	5981C62G10	5CLE-GNM-C	9078A68G32
48DBA1-150E	5980C17G16	4NPL-1875	140D318G01	5BHCL-500E	5981C62G09	5CLE-GNM-D	9078A68G36
48DBA1-15E	5980C17G06	4NPL-2000	140D318G07	5BHCL-600E	5981C62G08	5CLE-GNM-E	9078A68G40
48DBA1-200E	5980C17G17	4NPL-2825	140D318G02	5BHCL-750E	5981C58G01	5CLE-PDM-C	9078A65G11
48DBA1-20E	5980C17G07	4NPL-3000	140D318G06	5BHCL-900E	5981C58G02	5CLE-PDM-D	9078A65G16
48DBA1-25E	5980C17G08	4NPL-3500	5982C64G01	5BHLE-100E	5983C02G10	5CLE-PDM-E	9078A65G21
48DBA1-3	5980C17G02	4NPL-5000	5982C64G02	5BHLE-10E	5983C02G01	5CLE-PNM-C	9078A68G11
48DBA1-30E	5980C17G09	4NPL-900	140D318G04	5BHLE-125E	5983C02G11	5CLE-PNM-D	9078A68G16
48DBA1-40E	5980C17G10	5ACLS-12R	151D933G02	5BHLE-150E	5983C02G12	5CLE-PNM-E	9078A68G21
48DBA1-50E	5980C17G11	5ACLS-18R	151D933G03	5BHLE-15E	5983C02G02	5CLS-12R	151D961G02
48DBA1-5E	5980C17G03	5ACLS-24R	151D933G04	5BHLE-175E	5983C02G13	5CLS-18R	151D961G03
48DBA1-65E	5980C17G12	5ACLS-2R	449D597G02	5BHLE-200E	5983C02G14	5CLS-24R	151D961G04
48DBA1-7E	5980C17G04	5ACLS-30	449D597G01	5BHLE-20E	5983C02G03	5CLS-2R	151D241G02
48DBA1-80E	5980C17G13	5ACLS-3R	449D597G03	5BHLE-250E	5983C02G15	5CLS-30	151D241G01
48DBA2-5	22A6782G05	5ACLS-4R	449D597G04	5BHLE-25E	5983C02G04	5CLS-3R	151D241G03
48DBA2-100E	18A7330G44	5ACLS-5R	449D597G05	5BHLE-300E	5983C02G16	5CLS-4R	151D241G04
48DBA2-10E	18A7330G35	5ACLS-6R	449D597G06	5BHLE-30E	5983C02G05	5CLS-5R	151D241G05
48DBA2-125E	18A7330G45	5ACLS-9R	151D933G01	5BHLE-350E	5983C02G17	5CLS-6R	151D241G06
48DBA2-150E	18A7330G46	5AHLE-100E	5981C46G10	5BHLE-400E	5983C02G18	5CLS70-12R	140D045G04
48DBA2-15E	18A7330G36	5AHLE-10E	5981C46G01	5BHLE-40E	5983C02G06	5CLS70-18R	140D045G06
48DBA2-200E	18A7330G47	5AHLE-125E	5981C46G11	5BHLE-450E	5983C02G19	5CLS70-24R	140D045G03
48DBA2-20E	18A7330G37	5AHLE-150E	5981C46G12	5BHLE-50E	5983C02G07	5CLS70-2R	5981C81G06
48DBA2-25E	18A7330G38	5AHLE-15E	5981C46G02	5BHLE-65E	5983C02G08	5CLS70-32R	140D045G01
48DBA2-3	505D420G08	5AHLE-175E	5981C46G13	5BHLE-80E	5983C02G09	5CLS70-36R	140D045G02
48DBA2-30E	18A7330G39	5AHLE-200E	5981C46G14	5CLE-100E	5981C65G05	5CLS70-3R	5981C81G05
48DBA2-40E	18A7330G40	5AHLE-20E	5981C46G03	5CLE-10E-D	5981C29G01	5CLS70-44R	140D045G05
48DBA2-50E	18A7330G41	5AHLE-250E	5981C46G15	5CLE-1100E	9570D70G01	5CLS70-4R	5981C81G04
48DBA2-5E	18A7330G33	5AHLE-25E	5981C46G04	5CLE-125E	5981C65G06	5CLS70-5R	5981C81G03
48DBA2-65E	18A7330G42	5AHLE-300E	5981C46G16	5CLE-1350E	9570D70G02	5CLS70-6R	5981C81G12
48DBA2-780E	18A7330G43	5AHLE-30E	5981C46G05	5CLE-150E	5981C65G07	5CLS70-9R	5981C81G01

Appendix 3—Catalog Number/Style Number Cross Reference

Catalog Number	Style Number	Catalog Number	Style Number	Catalog Number	Style Number	Catalog Number	Style Number
5CLS75-24R	151D257G05	5HCL-500E	5981C62G01	5NCLPT-1E-A	5981C05G05	6MDSL-MA800	5982C90G08
5CLS75-32R	151D257G02	5HCL-50E	5981C65G07	5NCLPT-2E-A	5981C05G04	6MDSL-MB1200	5982C91G01
5CLS75-36R	151D257G01	5HCL-600E	5981C62G02	5NCLPT-3E-A	5981C05G03	6MDSL-MB1600	5982C91G02
5CLS-9R	151D961G01	5HCL-65E	5981C65G08	5NCLPT-5E-A	5981C05G02	6MDSL-MB2000	5982C91G03
5CLT-12C	678C249G02	5HCL-80E	5981C65G09	5RBA2-GDM	9078A25G02	6MDSL-MC1000	5982C92G02
5CLT-18C	678C276G02	5HCLS-12R	151D962G02	5RBA2-GDM	9078A25G02	6MDSL-MC1200	5982C92G03
5CLT-25C	678C276G05	5HCLS-18R	151D962G03	5RBA2-GNM	9078A33G16	6MDSL-MC1600	5982C92G04
5CLT-30C	680C386G02	5HCLS-24R	151D962G04	5RBA2-GNM	9078A33G16	6MDSL-MC2000	5982C92G05
5CLT-45C	680C386G05	5HCLS-2R	151D240G02	5RBA2-PDM	9078A25G01	6MDSL-MC800	5982C92G01
5CLT-60C	680C386G03	5HCLS-30	151D240G01	5RBA2-PDM	9078A25G01	6MDSL-MD2500	5982C93G01
5CLT-8C	678C248G05	5HCLS-3R	151D240G03	5RBA2-PNM	9078A33G06	6MDSL-MD3000	5982C93G02
5CX-10C	151D254G11	5HCLS-4R	151D240G04	5RBA2-PNM	9078A33G06	72DBA1-0.5	5980C17G21
5CX-12C	151D254G12	5HCLS-5R	151D240G05	5RBA4-GDM	9078A19G02	72DBA1-100E	5980C17G34
5CX-18C	5978C70G01	5HCLS-6R	151D240G06	5RBA4-GDM	9078A19G02	72DBA1-10E	5980C17G25
5CX-20C	5978C70G02	5HCLS-9R	151D962G01	5RBA4-GNM	9078A33G19	72DBA1-125E	5980C17G35
5CX-21C	151D254G04	5HLE-100E	5981C64G05	5RBA4-GNM	9078A33G19	72DBA1-150E	5980C17G36
5CX-25C	151D254G03	5HLE-10E	5981C28G01	5RBA4-PDM	9078A19G01	72DBA1-15E	5980C17G26
5CX-30C	5978C70G04	5HLE-125E	5981C64G06	5RBA4-PDM	9078A19G01	72DBA1-200E	5980C17G37
5CX-35C	151D254G06	5HLE-150E	5981C64G07	5RBA4-PNM	9078A33G06	72DBA1-20E	5980C17G27
5CX-40C	5978C70G05	5HLE-15E	5981C28G02	5RBA4-PNM	9078A33G06	72DBA1-25E	5980C17G28
5CX-50C	5978C70G06	5HLE-175E	5981C64G08	5RBA8-GNM	9078A33G22	72DBA1-3	5980C17G22
5CX-60C	151D254G09	5HLE-200E	5981C64G09	5RBA8-GNM	9078A33G22	72DBA1-30E	5980C17G29
5CX-65C	5978C70G07	5HLE-20E	5981C28G03	5RBA8-GNM	9078A33G22	72DBA1-40E	5980C17G30
5CX-75C	5978C70G08	5HLE-250E	5981C64G10	5RBA8-PNM	9078A33G22	72DBA1-50E	5980C17G31
5CX-GDM-G	151D885G01	5HLE-25E	5981C28G04	5RBA8-PNM	9078A33G22	72DBA1-5E	5980C17G23
5CX-GNM-G	151D884G01	5HLE-300E	5981C66G01	5RBA8-PNM	9078A33G22	72DBA1-65E	5980C17G32
5CXI-10C	151D254G31	5HLE-30E	5981C28G05	6DSL-A150	140D316G01	72DBA1-7E	5980C17G24
5CXI-12C	151D254G32	5HLE-350E	5981C66G02	6DSL-A200	140D316G02	72DBA1-80E	5980C17G33
5CXI-18C	5978C70G21	5HLE-400E	5981C66G03	6DSL-A250	140D316G03	72DBA2-.5	22A6782G06
5CXI-20C	5978C70G22	5HLE-40E	5981C64G01	6DSL-A300	140D316G04	72DBA2-100E	11A8127G13
5CXI-21C	151D254G24	5HLE-450E	5981C66G04	6DSL-A400	140D316G05	72DBA2-10E	11A8127G04
5CXI-25C	151D254G23	5HLE-50E	5981C64G02	6DSL-A600	140D316G06	72DBA2-125E	11A8127G14
5CXI-30C	5978C70G24	5HLE-65E	5981C64G03	6DSL-A800	140D316G07	72DBA2-150E	11A8127G15
5CXI-35C	151D254G26	5HLE-80E	5981C64G04	6DSL-B1200	140D316G10	72DBA2-15E	11A8127G05
5CXI-40C	5978C70G25	5HLE-GDM-D	5981C03G04	6DSL-B1600	140D316G11	72DBA2-200E	11A8127G16
5CXI-50C	5978C70G26	5HLE-GDM-E	5981C03G16	6DSL-B3000	140D316G12	72DBA2-20E	11A8127G06
5CXI-60C	151D254G29	5HLE-GNM-D	5981C03G10	6DSL-C1000	151D932G02	72DBA2-25E	11A8127G07
5CXI-65C	5978C70G27	5HLE-GNM-E	5981C03G22	6DSL-C1200	151D932G03	72DBA2-3	505D420G09
5CXI-75C	5978C70G28	5HLE-PDM-D	5981C03G01	6DSL-C1600	151D932G04	72DBA2-30E	11A8127G08
5HCL-100E	5981C65G10	5HLE-PDM-E	5981C03G13	6DSL-C2000	151D932G05	72DBA2-40E	11A8127G09
5HCL-10E	5981C29G01	5HLE-PNM-D	5981C03G07	6DSL-C800	151D932G01	72DBA2-50E	11A8127G10
5HCL-125E	5981C65G11	5HLE-PNM-E	5981C03G19	6DSL-D2500	151D932G09	72DBA2-5E	11A8127G02
5HCL-150E	5981C65G12	5LCLS-12R	676C546G25	6DSL-D3000	151D932G10	72DBA2-65E	11A8127G11
5HCL-15E	5981C29G02	5LCLS-18R	304C463G03	6DSL-E2500	5980C01G01	72DBA2-7E	11A8127G03
5HCL-200E	5981C62G07	5LCLS-24R	304C463G04	6DSL-E3000	5980C01G02	72DBA2-80E	11A8127G12
5HCL-20E	5981C29G03	5LCLS-2R	676C546G15	6DSL-E4000	5980C01G03	7ACLS-12R	151D963G07
5HCL-250E	5981C62G06	5LCLS-3R	676C546G16	6DSL-F5000	5980C01G04	7ACLS18R	151D963G10
5HCL-25E	5981C29G04	5LCLS-4R	676C546G17	6MDSL-MA150	5982C90G01	7ACLS-24R	151D963G11
5HCL-300E	5981C62G05	5LCLS-5R	676C546G18	6MDSL-MA200	5982C90G02	7ACLS-9R	151D963G06
5HCL-30E	5981C29G05	5LCLS-6R	676C546G19	6MDSL-MA250	5982C90G03	7BCLS-12R	5982C36G07
5HCL-400E	5981C62G04	5LCLS-9R	676C546G22	6MDSL-MA300	5982C90G04	7BCLS-18R	5982C36G08
5HCL-40E	5981C65G06	5NCLPT-0.5E-A	5981C05G06	6MDSL-MA400	5982C90G05	7BCLS-24R	5982C36G09
5HCL-450E	5981C62G03	5NCLPT-10E-A	5981C05G01	6MDSL-MA600	5982C90G07	7BCLS-2R	5982C36G01

Appendix 3—Catalog Number/Style Number Cross Reference

Catalog Number	Style Number	Catalog Number	Style Number	Catalog Number	Style Number	Catalog Number	Style Number
7BCLS-3R	5982C36G02	8BA4-5	116D977A01	8CLE-40E	5981C17G04	8CX-8C	5978C62G06
7BCLS-44R	9570D69G01	8BA4-100E	116D977A13	8CLE-50E	5981C17G05	8CX-GDM-G	151D885G02
7BCLS-44R	9570D69G01	8BA4-10E	116D977A04	8CLE-65E	5981C17G06	8CX-GNM-G	151D884G02
7BCLS-4R	5982C36G03	8BA4-125E	116D977A14	8CLE-80E	5981C17G07	8CXI-10C	151D255G31
7BCLS-5R	5982C36G04	8BA4-150E	116D977A15	8CLE-GDM-C	9078A65G32	8CXI-12C	151D255G32
7BCLS-6R	5982C36G05	8BA4-15E	116D977A05	8CLE-GDM-D	9078A65G36	8CXI-15C	151D255G26
7BCLS-9R	5982C36G06	8BA4-200E	116D977A16	8CLE-GDM-E	9078A65G40	8CXI-18C	5978C72G21
7CLS-12R	5982C01G07	8BA4-20E	116D977A06	8CLE-GNM-C	9078A68G33	8CXI-20C	5978C72G22
7CLS-18R	5982C01G10	8BA4-250E	116D977A17	8CLE-GNM-D	9078A68G37	8CXI-25C	5978C72G23
7CLS-24R	5982C01G11	8BA4-25E	116D977A07	8CLE-GNM-E	9078A68G41	8CXI-3.5C	151D255G21
7CLS70-24R	5979C91G01	8BA4-300E	116D977A18	8CLE-PDM-C	9078A65G12	8CXI-30C	5978C72G24
7CLS70-36R	5979C91G02	8BA4-30E	116D977A08	8CLE-PDM-D	9078A65G17	8CXI-35C	151D255G29
7CLS70-44R	5980C03G01	8BA4-400E	116D977A19	8CLE-PDM-E	9078A65G22	8CXI-4.5C	5978C62G24
7CLS-9R	5982C01G06	8BA4-40E	116D977A09	8CLE-PNM-C	9078A68G12	8CXI-40C	5978C72G25
8ACLS-2R	151D963G01	8BA4-50E	116D977A10	8CLE-PNM-D	9078A68G17	8CXI-4C	151D255G22
8ACLS-3R	151D963G02	8BA4-5E	116D977A02	8CLE-PNM-E	9078A68G22	8CXI-6C	5978C62G25
8ACLS-4R	151D963G03	8BA4-65E	116D977A11	8CLS-110	151D256G06	8CXI-7C	151D255G23
8ACLS-5R	151D963G04	8BA4-7E	116D977A03	8CLS-125	151D256G07	8CXI-8C	5978C62G26
8ACLS-6R	151D963G05	8BA4-80E	116D977A12	8CLS-15	151D256G01	8CXN-100C	9570D01G02
8AHLE-100E	5981C47G10	8BA4-NH	310C196G01	8CLS-150	151D256G11	8CXN-125C	9570D01G03
8AHLE-10E	5981C47G01	8BHLE-100E	5983C03G10	8CLS-200	151D256G12	8CXN-150C	9570D01G04
8AHLE-125E	5981C47G11	8BHLE-10E	5983C03G01	8CLS-225	151D256G13	8CXN-200C	9570D01G05
8AHLE-150E	5981C47G12	8BHLE-125E	5983C03G11	8CLS-2R	5982C01G01	8CXN-250C	9570D01G06
8AHLE-15E	5981C47G02	8BHLE-150E	5983C03G12	8CLS-30	151D256G02	8CXN-60C	9570D01G01
8AHLE-175E	5981C47G13	8BHLE-15E	5983C03G02	8CLS-3R	5982C01G02	8DBA1-0.5	5980C15G01
8AHLE-200E	5981C47G14	8BHLE-175E	5983C03G13	8CLS-4R	5982C01G03	8DBA1-100E	5980C15G14
8AHLE-20E	5981C47G03	8BHLE-200E	5983C03G14	8CLS-5R	5982C01G04	8DBA1-10E	5980C15G05
8AHLE-250E	5981C47G15	8BHLE-20E	5983C03G03	8CLS-60	151D256G03	8DBA1-125E	5980C15G15
8AHLE-25E	5981C47G04	8BHLE-250E	5983C03G15	8CLS-6R	5982C01G05	8DBA1-150E	5980C15G16
8AHLE-300E	5981C47G16	8BHLE-25E	5983C03G04	8CLS-70	151D256G04	8DBA1-15E	5980C15G06
8AHLE-30E	5981C47G05	8BHLE-300E	5983C03G16	8CLS-90	151D256G05	8DBA1-200E	5980C15G17
8AHLE-350E	5981C47G17	8BHLE-30E	5983C03G05	8CLT-12C	591C273G03	8DBA1-20E	5980C15G07
8AHLE-40E	5981C47G06	8BHLE-350E	5983C03G17	8CLT-18C	678C276G03	8DBA1-25E	5980C15G08
8AHLE-50E	5981C47G07	8BHLE-40E	5983C03G06	8CLT-25C	678C276G06	8DBA1-3	5980C15G02
8AHLE-65E	5981C47G08	8BHLE-50E	5983C03G07	8CLT-30CL	678C290G01	8DBA1-30E	5980C15G09
8AHLE-80E	5981C47G09	8BHLE-65E	5983C03G08	8CLT-30CS	680C386G01	8DBA1-40E	5980C15G10
8BA2-5	117D123A01	8BHLE-80E	5983C03G09	8CLT-45C	680C386G06	8DBA1-50E	5980C15G11
8BA2-100E	117D123A13	8CLE-100E	5981C17G08	8CLT-5C	678C248G03	8DBA1-5E	5980C15G03
8BA2-10E	117D123A04	8CLE-10E	5981C31G01	8CLT-8C	678C248G06	8DBA1-65E	5980C15G12
8BA2-125E	117D123A14	8CLE-125E	5981C17G09	8CX-10C	151D255G11	8DBA1-7E	5980C15G04
8BA2-150E	117D123A15	8CLE-150E	5981C17G10	8CX-12C	151D255G12	8DBA1-80E	5980C15G13
8BA2-15E	117D123A05	8CLE-15E	678C240G07	8CX-15C	151D255G06	8HCL-100E	5983C05G08
8BA2-200E	117D123A16	8CLE-15E-D	5981C31G02	8CX-18C	5978C72G01	8HCL-125E	5983C05G07
8BA2-20E	117D123A06	8CLE-175E	5981C17G11	8CX-20C	5978C72G02	8HCL-150E	5983C05G06
8BA2-25E	117D123A07	8CLE-200E	5981C21G01	8CX-25C	5978C72G03	8HCL-175E	5983C05G05
8BA2-30E	117D123A08	8CLE-20E	678C240G08	8CX-3.5C	151D255G01	8HCL-200E	5983C05G01
8BA2-40E	117D123A09	8CLE-20E-D	5981C31G03	8CX-30C	5978C72G04	8HCL-250E	5983C05G02
8BA2-50E	117D123A10	8CLE-250E	5981C21G02	8CX-35C	151D255G09	8HCL-300E	5983C05G03
8BA2-5E	117D123A02	8CLE-25E	678C240G09	8CX-4.5C	5978C62G04	8HCL-350E	5983C05G04
8BA2-65E	117D123A11	8CLE-25E-D	5981C31G04	8CX-40C	5978C72G05	8HCL-65E	5983C05G10
8BA2-7E	117D123A03	8CLE-300E	5981C21G03	8CX-4C	151D255G02	8HCL-80E	5983C05G09
8BA2-80E	117D123A12	8CLE-30E	5981C31G05	8CX-6C	5978C62G05	8HLE-100E	5981C16G08
8BA2-NH	310C198G01	8CLE-350E	5981C21G04	8CX-7C	151D255G03	8HLE-10E	5981C30G01

Appendix 3—Catalog Number/Style Number Cross Reference

Catalog Number	Style Number	Catalog Number	Style Number	Catalog Number	Style Number	Catalog Number	Style Number
8HLE-125E	5981C16G09	8RBA2-INH-B	5984C18G01	8RBA8-INH	5981C54G01	92DBA2-125E	11A8127G34
8HLE-150E	5981C16G10	8RBA2-INH-B	5984C18G01	8RBA8-INH	5981C54G01	92DBA2-150E	11A8127G35
8HLE-15E	5981C30G02	8RBA2-ISHNT	309C548G09	8RBA8-PNM	9078A33G12	92DBA2-15E	11A8127G25
8HLE-175E	5981C16G11	8RBA2-NH	677C370G01	8RBA8-PNM	9078A33G12	92DBA2-200E	11A8127G36
8HLE-200E	5981C22G01	8RBA2-NH	677C370G01	8RBA8-PNM	9078A33G12	92DBA2-20E	11A8127G26
8HLE-20E	5981C30G03	8RBA2-PDM	9078A25G08	8RBT2-100E	449D671A14	92DBA2-25E	11A8127G27
8HLE-250E	5981C22G02	8RBA2-PDM	9078A25G08	8RBT2-125E	449D671A15	92DBA2-3	11A8127G21
8HLE-25E	5981C30G04	8RBA2-PNM	9078A33G02	8RBT2-150E	449D671A16	92DBA2-30E	11A8127G28
8HLE-300E	5981C22G03	8RBA2-PNM	9078A33G02	8RBT2-200E	449D671A18	92DBA2-40E	11A8127G29
8HLE-30E	5981C30G05	8RBA4-.5	5982C44A01	8RBT2-20E	449D671A07	92DBA2-50E	11A8127G30
8HLE-350E	5981C22G04	8RBA4-100E	5982C44A14	8RBT2-25E	449D671A08	92DBA2-5E	11A8127G22
8HLE-40E	5981C16G04	8RBA4-10E	5982C44A05	8RBT2-30E	449D671A09	92DBA2-65E	11A8127G31
8HLE-50E	5981C16G05	8RBA4-125E	5982C44A15	8RBT2-40E	449D671A10	92DBA2-780E	11A8127G32
8HLE-65E	5981C16G06	8RBA4-150E	5982C44A16	8RBT2-50E	449D671A11	92DBA2-7E	11A8127G23
8HLE-80E	5981C16G07	8RBA4-15E	5982C44A06	8RBT2-65E	449D671A12	CLE-DF-C	9078A63G02
8HLE-GDM-D	5981C03G05	8RBA4-175E	5982C44A17	8RBT2-80E	449D671A13	CLE-DF-D	9078A63G03
8HLE-GDM-E	5981C03G14	8RBA4-200E	5982C44A18	8RBT4-100E	5982C49A14	CLE-DF-E	9078A63G04
8HLE-GNM-D	5981C03G11	8RBA4-20E	5982C44A07	8RBT4-125E	5982C49A15	CLE-DL-C	9078A63G04
8HLE-GNM-E	5981C03G23	8RBA4-250E	5982C44A19	8RBT4-150E	5982C49A16	CLE-DL-D	9078A67G03
8HLE-PDM-D	5981C03G02	8RBA4-25E	5982C44A08	8RBT4-200E	5982C49A18	CLE-DL-E	9078A64G04
8HLE-PDM-E	5981C03G14	8RBA4-3	5982C44A02	8RBT4-20E	5982C49A07	CLE-NL-C	9078A67G02
8HLE-PNM-D	5981C03G08	8RBA4-300E	5982C44A20	8RBT4-250E	5982C49A19	CLE-NLC-C	9078A67G17
8HLE-PNM-E	5981C03G20	8RBA4-30E	5982C44A09	8RBT4-25E	5982C49A08	CLE-NLC-D	9078A67G20
8NCLPT-0.5E-A	5981C06G06	8RBA4-400E	5982C44A22	8RBT4-300E	5982C49A20	CLE-NLC-E	9078A67G15
8NCLPT-10E-B	5981C06G01	8RBA4-40E	5982C44A10	8RBT4-30E	5982C49A09	CLE-NL-D	9078A67G03
8NCLPT-1E-A	5981C06G05	8RBA4-50E	5982C44A11	8RBT4-400E	5982C49A22	CLE-NL-E	9078A67G04
8NCLPT-2E-A	5981C06G04	8RBA4-5E	5982C44A03	8RBT4-40E	5982C49A10	CLS-700 DUMMY	591C172G01
8NCLPT-3E-B	5981C06G03	8RBA4-65E	5982C44A12	8RBT4-50E	5982C49A11	CX-DF	151D885G06
8NCLPT-5E-B	5981C06G02	8RBA4-7E	5982C44A04	8RBT4-65E	5982C49A12	CX-DL	151D885G05
8RBA2-100E	423D814A14	8RBA4-80E	5982C44A13	8RBT4-80E	5982C49A13	CXN-CLAMP	7275A85G02
8RBA2-10E	423D814A05	8RBA4-DH	5981C52G01	8RDB2-DH	309C558G05	CX-NL	151D884G08
8RBA2-125E	423D814A15	8RBA4-DH	5981C52G01	8RDB2-DH	309C558G05	DBU17-100E	5981C76G13
8RBA2-150E	423D814A16	8RBA4-GDM	9078A25G09	8RDB2-HUM	140D349G16	DBU17-100K	5981C75G14
8RBA2-15E	423D814A06	8RBA4-GDM	9078A25G09	8RDB2-HVM	140D340G16	DBU17-100SE	5981C77G09
8RBA2-175E	423D814A17	8RBA4-GNM	9078A33G17	8RDB2-SHNT	308C548G01	DBU17-10E	5981C76G03
8RBA2-200E	423D814A18	8RBA4-GNM	9078A33G17	8RDB2-UM	140D349G11	DBU17-10K	5981C75G04
8RBA2-20E	423D814A07	8RBA4-IDH	5981C52G01	8RDB2-VM	140D340G11	DBU17-125E	5981C76G14
8RBA2-25E	423D814A08	8RBA4-IDH	5981C52G01	8RDB4-DH	310C131G01	DBU17-125SE	5981C77G10
8RBA2-30E	423D814A09	8RBA4-INH	5981C53G01	8RDB4-DH	310C131G01	DBU17-12K	5981C75G05
8RBA2-40E	423D814A10	8RBA4-INH	5981C53G01	8RDB4-DH	310C131G01	DBU17-13E	5981C76G04
8RBA2-50E	423D814A11	8RBA4-INH-B	5984C17G01	8RDB4-DH	310C131G01	DBU17-140K	5981C75G15
8RBA2-65E	423D814A12	8RBA4-INH-B	5984C17G01	8RDB4-HUM	140D346G16	DBU17-150E	5981C76G15
8RBA2-80E	423D814A13	8RBA4-ISHNT	678C283G05	8RDB4-HVM	140D341G16	DBU17-150SE	5981C77G11
8RBA2-DH	309C558G01	8RBA4-ISHNT	678C283G05	8RDB4-SHNT	678C284G01	DBU17-15E	5981C76G05
8RBA2-DH	309C558G01	8RBA4-NH	677C371G01	8RDB4-SHNT	678C284G01	DBU17-15K	5981C75G06
8RBA2-GDM	9078A25G09	8RBA4-NH	677C371G01	8RDB4-UM	140D346G11	DBU17-15SE	5981C77G01
8RBA2-GDM	9078A25G09	8RBA4-PDM	9078A25G08	8RDB4-VM	140D341G11	DBU17-175E	5981C76G16
8RBA2-GNM	9078A33G17	8RBA4-PDM	9078A25G08	8RDB8-HUM	140D354G16	DBU17-175SE	5981C77G12
8RBA2-GNM	9078A33G17	8RBA4-PNM	9078A33G02	8RDB8-HVM	140D342G16	DBU17-200E	5981C76G17
8RBA2-IDH	5981C50G01	8RBA4-PNM	9078A33G02	8RDB8-UM	140D354G11	DBU17-200K	5981C75G16
8RBA2-IDH	5981C50G01	8RBA8-GNM	9078A33G23	8RDB8-VM	140D342G11	DBU17-200SE	5981C77G13
8RBA2-INH	5981C51G01	8RBA8-GNM	9078A33G23	92DBA2-100E	11A8127G33	DBU17-20E	5981C76G06
8RBA2-INH	5981C51G01	8RBA8-GNM	9078A33G23	92DBA2-10E	11A8127G24	DBU17-20K	5981C75G07

Appendix 3—Catalog Number/Style Number Cross Reference

Catalog Number	Style Number	Catalog Number	Style Number	Catalog Number	Style Number	Catalog Number	Style Number
DBU17-20SE	5981C77G02	DBU27-175SE	5981C77G12	DBU38-150E	5981C76G15	RBA2-FLTR	309C024G05
DBU17-25E	5981C76G07	DBU27-200E	5981C76G17	DBU38-150SE	5981C77G11	RBA2-FLTR-1	309C024G03
DBU17-25K	5981C75G08	DBU27-200K	5981C75G16	DBU38-15E	5981C76G05	RBA4-COND	309C024G04
DBU17-25SE	5981C77G03	DBU27-200SE	5981C77G13	DBU38-15K	5981C75G06	RBA4-COND	310C197G04
DBU17-30E	5981C76G08	DBU27-20E	5981C76G06	DBU38-15SE	5981C77G01	RBA4-COND-1	310C197G06
DBU17-30K	5981C75G09	DBU27-20K	5981C75G07	DBU38-175E	5981C76G16	RBA4-FLTR	591C607G01
DBU17-30SE	5981C77G04	DBU27-20SE	5981C77G02	DBU38-175SE	5981C77G12	RBA4-FLTR-1	591C607G03
DBU17-3K	5981C75G01	DBU27-25E	5981C76G07	DBU38-200E	5981C76G17	RBA4-FLTR-HC	591C607G02
DBU17-40E	5981C76G09	DBU27-25K	5981C75G08	DBU38-200K	5981C75G16	RBA4-FLTR-HC-1	591C607G04
DBU17-40K	5981C75G10	DBU27-25SE	5981C77G03	DBU38-200SE	5981C77G13	RDB2-UL	140D349G20
DBU17-40SE	5981C77G05	DBU27-30E	5981C76G08	DBU38-20E	5981C76G06	RDB2-VL	140D340G20
DBU17-50E	5981C76G10	DBU27-30K	5981C75G09	DBU38-20K	5981C75G07	RDB4-UL	140D346G20
DBU17-50K	5981C75G11	DBU27-30SE	5981C77G04	DBU38-20SE	5981C77G02	RDB4-VL	140D341G20
DBU17-50SE	5981C77G06	DBU27-3K	5981C75G01	DBU38-25E	5981C76G07	RDB8-UL	140D354G20
DBU17-5E	5981C76G01	DBU27-40E	5981C76G09	DBU38-25K	5981C75G08	RDB8-VL	140D342G20
DBU17-65E	5981C76G11	DBU27-40K	5981C75G10	DBU38-25SE	5981C77G03	Spring and shunt assy. for 15BA2-NH	309C054G02
DBU17-65K	5981C75G12	DBU27-40SE	5981C77G05	DBU38-30E	5981C76G08	Spring and shunt assy. for 676C878G02	676C878G02
DBU17-65SE	5981C77G07	DBU27-50E	5981C76G10	DBU38-30K	5981C75G09	Spring and shunt assy. for 8BA4-NH	309C054G01
DBU17-6K	5981C75G02	DBU27-50K	5981C75G11	DBU38-30SE	5981C77G04	Spring and shunt assy. for 8BA2-NH	309C054G01
DBU17-7E	5981C76G02	DBU27-50SE	5981C77G06	DBU38-3K	5981C75G01	Spring and shunt assy. for 676C878G01	676C878G01
DBU17-80E	5981C76G12	DBU27-5E	5981C76G01	DBU38-40E	5981C76G09	Spring and shunt assy. for 8BA4-NH	676C878G01
DBU1780K	5981C75G03	DBU27-65E	5981C76G11	DBU38-40K	5981C75G10		
DBU17-80K	5981C75G13	DBU27-65K	5981C75G12	DBU38-40SE	5981C77G05		
DBU17-80SE	5981C77G08	DBU27-65SE	5981C77G07	DBU38-50E	5981C76G10		
DBU17-DL-L	5982C48G02	DBU27-6K	5981C75G02	DBU38-50K	5981C75G11		
DBU17-DL-R	5982C48G03	DBU27-7E	5981C76G02	DBU38-50SE	5981C77G06		
DBU17-DM	5984C39G01	DBU27-80E	5981C76G12	DBU38-5E	5981C76G01		
DBU17-GDM-L	5982C45G08	DBU27-80K	5981C75G13	DBU38-65E	5981C76G11		
DBU17-GDM-R	5982C45G07	DBU27-80SE	5981C77G08	DBU38-65K	5981C75G12		
DBU17-GNM-L	5984C25G07	DBU27-8K	5981C75G03	DBU38-65SE	5981C77G07		
DBU17-GNMP-L	5984C25G01	DBU27-DL-L	5982C48G05	DBU38-6K	5981C75G02		
DBU17-GNMP-R	5984C25G04	DBU27-DL-R	5982C48G06	DBU38-7E	5981C76G02		
DBU17-GNM-R	5984C25G10	DBU27-DM	5984C38G01	DBU38-80E	5981C76G12		
DBU17-NL-L	5984C29G01	DBU27-GDM-L	5982C45G05	DBU38-80K	5981C75G13		
DBU17-NLP-L	5984C29G07	DBU27-GDM-R	5982C45G06	DBU38-80SE	5981C77G08		
DBU17-NLP-R	5984C29G10	DBU27-GNM-L	5984C25G08	DBU38-8K	5981C75G03		
DBU17-NL-R	5984C29G04	DBU27-GNMP-L	5984C25G02	DBU38-GNM-L	5984C25G09		
DBU27-100E	5981C76G13	DBU27-GNMP-R	5984C25G05	DBU38-GNMP-L	5984C25G03		
DBU27-100K	5981C75G14	DBU27-GNM-R	5984C25G11	DBU38-GNMP-R	5984C25G06		
DBU27-100SE	5981C77G09	DBU27-NL-L	5984C29G02	DBU38-GNM-R	5984C25G12		
DBU27-10E	5981C76G03	DBU27-NLP-L	5984C29G08	DBU38-NL-L	5984C29G03		
DBU27-10K	5981C75G04	DBU27-NLP-R	5984C29G11	DBU38-NLP-L	5984C29G09		
DBU27-125E	5981C76G14	DBU27-NL-R	5984C29G05	DBU38-NLP-R	5984C29G12		
DBU27-125SE	5981C77G10	DBU38-100E	5981C76G13	DBU38-NL-R	5984C29G06		
DBU27-12K	5981C75G05	DBU38-100K	5981C75G14	DBU-EFID	7187A11G04		
DBU27-13E	5981C76G04	DBU38-100SE	5981C77G09	DBU-EFOD	7187A11G02		
DBU27-140K	5981C75G15	DBU38-10E	5981C76G03	DBU-MFLR	5981C69G02		
DBU27-150E	5981C76G15	DBU38-10K	5981C75G04	HANDLE ASSEMBLY	435B592G02		
DBU27-150SE	5981C77G11	DBU38-125E	5981C76G14	HCL-NL	5982C19G04		
DBU27-15E	5981C76G05	DBU38-125SE	5981C77G10	RBA2-COND	309C024G03		
DBU27-15K	5981C75G06	DBU38-12K	5981C75G05	RBA2-COND	310C197G03		
DBU27-15SE	5981C77G01	DBU38-13E	5981C76G04	RBA2-COND-1	310C197G05		
DBU27-175E	5981C76G16	DBU38-140K	5981C75G15	RBA2-FLTR	309C024G03		

Appendix 3—Catalog Number/Style Number Cross Reference

Style Number—Catalog Number Cross Reference

Style Number	Catalog Number	Style Number	Catalog Number	Style Number	Catalog Number	Style Number	Catalog Number
8BA4-.5	116D977A01	25BA4-80E	116D977A52	15BA2-40E	117D123A25	72DBA2-65E	11A8127G11
8BA4-5E	116D977A02	25BA4-100E	116D977A53	15BA2-50E	117D123A26	72DBA2-80E	11A8127G12
8BA4-7E	116D977A03	25BA4-125E	116D977A54	15BA2-65E	117D123A27	72DBA2-100E	11A8127G13
8BA4-10E	116D977A04	25BA4-150E	116D977A55	15BA2-80E	117D123A28	72DBA2-125E	11A8127G14
8BA4-15E	116D977A05	25BA4-200E	116D977A56	15BA2-100E	117D123A29	72DBA2-150E	11A8127G15
8BA4-20E	116D977A06	25BA4-250E	116D977A57	15BA2-125E	117D123A30	72DBA2-200E	11A8127G16
8BA4-25E	116D977A07	25BA4-300E	116D977A58	15BA2-150E	117D123A31	92DBA2-3	11A8127G21
8BA4-30E	116D977A08	38BA4-.5	116D977A61	15BA2-200E	117D123A32	92DBA2-5E	11A8127G22
8BA4-40E	116D977A09	38BA4-5E	116D977A62	25BA2-.5	117D123A33	92DBA2-7E	11A8127G23
8BA4-50E	116D977A10	38BA4-7E	116D977A63	25BA2-5E	117D123A34	92DBA2-10E	11A8127G24
8BA4-65E	116D977A11	38BA4-10E	116D977A64	25BA2-7E	117D123A35	92DBA2-15E	11A8127G25
8BA4-80E	116D977A12	38BA4-15E	116D977A65	25BA2-10E	117D123A36	92DBA2-20E	11A8127G26
8BA4-100E	116D977A13	38BA4-20E	116D977A66	25BA2-15E	117D123A37	92DBA2-25E	11A8127G27
8BA4-125E	116D977A14	38BA4-25E	116D977A67	25BA2-20E	117D123A38	92DBA2-30E	11A8127G28
8BA4-150E	116D977A15	38BA4-30E	116D977A68	25BA2-25E	117D123A39	92DBA2-40E	11A8127G29
8BA4-200E	116D977A16	38BA4-40E	116D977A69	25BA2-30E	117D123A40	92DBA2-50E	11A8127G30
8BA4-250E	116D977A17	38BA4-50E	116D977A70	25BA2-40E	117D123A41	92DBA2-65E	11A8127G31
8BA4-300E	116D977A18	38BA4-65E	116D977A71	25BA2-50E	117D123A42	92DBA2-780E	11A8127G32
8BA4-400E	116D977A19	38BA4-80E	116D977A72	25BA2-65E	117D123A43	92DBA2-100E	11A8127G33
15BA4-.5	116D977A21	38BA4-100E	116D977A73	25BA2-80E	117D123A44	92DBA2-125E	11A8127G34
15BA4-5E	116D977A22	38BA4-125E	116D977A74	25BA2-100E	117D123A45	92DBA2-150E	11A8127G35
15BA4-7E	116D977A23	38BA4-150E	116D977A75	25BA2-125E	117D123A46	92DBA2-200E	11A8127G36
15BA4-10E	116D977A24	38BA4-200E	116D977A76	25BA2-150E	117D123A47	121DBA2-3	11A8127G41
15BA4-15E	116D977A25	38BA4-250E	116D977A77	25BA2-200E	117D123A48	121DBA2-5E	11A8127G42
15BA4-20E	116D977A26	38BA4-300E	116D977A78	38BA2-.5	117D123A49	121DBA2-7E	11A8127G43
15BA4-25E	116D977A27	8BA2-.5	117D123A01	38BA2-5E	117D123A50	121DBA2-10E	11A8127G44
15BA4-30E	116D977A28	8BA2-5E	117D123A02	38BA2-7E	117D123A51	121DBA2-15E	11A8127G45
15BA4-40E	116D977A29	8BA2-7E	117D123A03	38BA2-10E	117D123A52	121DBA2-20E	11A8127G46
15BA4-50E	116D977A30	8BA2-10E	117D123A04	38BA2-15E	117D123A53	121DBA2-25E	11A8127G47
15BA4-65E	116D977A31	8BA2-15E	117D123A05	38BA2-20E	117D123A54	121DBA2-30E	11A8127G48
15BA4-80E	116D977A32	8BA2-20E	117D123A06	38BA2-25E	117D123A55	121DBA2-40E	11A8127G49
15BA4-100E	116D977A33	8BA2-25E	117D123A07	38BA2-30E	117D123A56	121DBA2-50E	11A8127G50
15BA4-125E	116D977A34	8BA2-30E	117D123A08	38BA2-40E	117D123A57	121DBA2-65E	11A8127G51
15BA4-150E	116D977A35	8BA2-40E	117D123A09	38BA2-50E	117D123A58	121DBA2-780E	11A8127G52
15BA4-200E	116D977A36	8BA2-50E	117D123A10	38BA2-65E	117D123A59	121DBA2-100E	11A8127G53
15BA4-250E	116D977A37	8BA2-65E	117D123A11	38BA2-80E	117D123A60	121DBA2-125E	11A8127G54
15BA4-300E	116D977A38	8BA2-80E	117D123A12	38BA2-100E	117D123A61	121DBA2-150E	11A8127G55
15BA4-400E	116D977A39	8BA2-100E	117D123A13	38BA2-125E	117D123A62	121DBA2-200E	11A8127G56
25BA4-.5	116D977A41	8BA2-125E	117D123A14	38BA2-150E	117D123A63	145DBA2-3	11A8127G61
25BA4-5E	116D977A42	8BA2-150E	117D123A15	38BA2-200E	117D123A64	145DBA2-5E	11A8127G62
25BA4-7E	116D977A43	8BA2-200E	117D123A16	72DBA2-5E	11A8127G02	145DBA2-7E	11A8127G63
25BA4-10E	116D977A44	15BA2-.5	117D123A17	72DBA2-7E	11A8127G03	145DBA2-10E	11A8127G64
25BA4-15E	116D977A45	15BA2-5E	117D123A18	72DBA2-10E	11A8127G04	145DBA2-15E	11A8127G65
25BA4-20E	116D977A46	15BA2-7E	117D123A19	72DBA2-15E	11A8127G05	145DBA2-20E	11A8127G66
25BA4-25E	116D977A47	15BA2-10E	117D123A20	72DBA2-20E	11A8127G06	145DBA2-25E	11A8127G67
25BA4-30E	116D977A48	15BA2-15E	117D123A21	72DBA2-25E	11A8127G07	145DBA2-30E	11A8127G68
25BA4-40E	116D977A49	15BA2-20E	117D123A22	72DBA2-30E	11A8127G08	145DBA2-40E	11A8127G69
25BA4-50E	116D977A50	15BA2-25E	117D123A23	72DBA2-40E	11A8127G09	145DBA2-50E	11A8127G70
25BA4-65E	116D977A51	15BA2-30E	117D123A24	72DBA2-50E	11A8127G10	145DBA2-65E	11A8127G71

Appendix 3—Catalog Number/Style Number Cross Reference

Style Number	Catalog Number	Style Number	Catalog Number	Style Number	Catalog Number	Style Number	Catalog Number
145DBA2-780E	11A8127G72	RDB8-VL	140D342G20	5CXI-35C	151D254G26	6DSL-C1000	151D932G02
145DBA2-100E	11A8127G73	8RDB4-UM	140D346G11	5CXI-60C	151D254G29	6DSL-C1200	151D932G03
145DBA2-125E	11A8127G74	15RDB4-UM	140D346G12	5CXI-10C	151D254G31	6DSL-C1600	151D932G04
145DBA2-150E	11A8127G75	25RDB4-UM	140D346G13	5CXI-12C	151D254G32	6DSL-C2000	151D932G05
145DBA2-200E	11A8127G76	38RDB4-UM	140D346G14	8CX-3.5C	151D255G01	6DSL-D2500	151D932G09
5CLS70-32R	140D045G01	8RDB4-HUM	140D346G16	8CX-4C	151D255G02	6DSL-D3000	151D932G10
5CLS70-36R	140D045G02	15RDB4-HUM	140D346G17	8CX-7C	151D255G03	5ACLS-9R	151D933G01
5CLS70-24R	140D045G03	25RDB4-HUM	140D346G18	8CX-15C	151D255G06	5ACLS-12R	151D933G02
5CLS70-12R	140D045G04	38RDB4-HUM	140D346G19	8CX-35C	151D255G09	5ACLS-18R	151D933G03
5CLS70-44R	140D045G05	RDB4-UL	140D346G20	8CX-10C	151D255G11	5ACLS-24R	151D933G04
5CLS70-18R	140D045G06	8RDB2-UM	140D349G11	8CX-12C	151D255G12	5CLS-9R	151D961G01
6DSL-A150	140D316G01	15RDB2-UM	140D349G12	8CXI-3.5C	151D255G21	5CLS-12R	151D961G02
6DSL-A200	140D316G02	15RDB2-UM	140D349G13	8CXI-4C	151D255G22	5CLS-18R	151D961G03
6DSL-A250	140D316G03	38RDB2-UM	140D349G14	8CXI-7C	151D255G23	5CLS-24R	151D961G04
6DSL-A300	140D316G04	8RDB2-HUM	140D349G16	8CXI-15C	151D255G26	5HCLS-9R	151D962G01
6DSL-A400	140D316G05	15RDB2-HUM	140D349G17	8CXI-35C	151D255G29	5HCLS-12R	151D962G02
6DSL-A600	140D316G06	25RDB2-HUM	140D349G18	8CXI-10C	151D255G31	5HCLS-18R	151D962G03
6DSL-A800	140D316G07	38RDB2-HUM	140D349G19	8CXI-12C	151D255G32	5HCLS-24R	151D962G04
6DSL-B1200	140D316G10	RDB2-UL	140D349G20	8CLS-15	151D256G01	8ACLS-2R	151D963G01
6DSL-B1600	140D316G11	8RDB8-UM	140D354G11	8CLS-30	151D256G02	8ACLS-3R	151D963G02
6DSL-B3000	140D316G12	15RDB8-UM	140D354G12	8CLS-60	151D256G03	8ACLS-4R	151D963G03
4NPL-1875	140D318G01	25RDB8-UM	140D354G13	8CLS-70	151D256G04	8ACLS-5R	151D963G04
4NPL-2825	140D318G02	38RDB8-UM	140D354G14	8CLS-90	151D256G05	8ACLS-6R	151D963G05
4NPL-900	140D318G04	8RDB8-HUM	140D354G16	8CLS-110	151D256G06	7ACLS-9R	151D963G06
4NPL-1300	140D318G05	15RDB8-HUM	140D354G17	8CLS-125	151D256G07	7ACLS-12R	151D963G07
4NPL-3000	140D318G06	25RDB8-HUM	140D354G18	8CLS-150	151D256G11	7ACLS18R	151D963G10
4NPL-2000	140D318G07	38RDB8-HUM	140D354G19	8CLS-200	151D256G12	7ACLS-24R	151D963G11
8RDB2-VM	140D340G11	RDB8-UL	140D354G20	8CLS-225	151D256G13	38DBA2-5E	18A7330G13
15RDB2-VM	140D340G12	4ACLS-26R	151D207G01	5CLS75-36R	151D257G01	38DBA2-7E	18A7330G14
25RDB2-VM	140D340G13	5HCLS-30	151D240G01	5CLS75-32R	151D257G02	38DBA2-10E	18A7330G15
38RDB2-VM	140D340G14	5HCLS-2R	151D240G02	151D257G03	151D257G03	38DBA2-15E	18A7330G16
8RDB2-HVM	140D340G16	5HCLS-3R	151D240G03	151D257G04	151D257G04	38DBA2-20E	18A7330G17
15RDB2-HVM	140D340G17	5HCLS-4R	151D240G04	5CLS75-24R	151D257G05	38DBA2-25E	18A7330G18
25RDB2-HVM	140D340G18	5HCLS-5R	151D240G05	15CX-4C	151D883G01	38DBA2-30E	18A7330G19
38RDB2-HVM	140D340G19	5HCLS-6R	151D240G06	15CX-7C	151D883G02	38DBA2-40E	18A7330G20
RDB2-VL	140D340G20	5CLS-30	151D241G01	15CX-15C	151D883G05	38DBA2-50E	18A7330G21
8RDB4-VM	140D341G11	5CLS-2R	151D241G02	15CX-10C	151D883G11	38DBA2-65E	18A7330G22
15RDB4-VM	140D341G12	5CLS-3R	151D241G03	15CX-3C	151D883G12	38DBA2-780E	18A7330G23
25RDB4-VM	140D341G13	5CLS-4R	151D241G04	15CXI-4C	151D883G21	38DBA2-100E	18A7330G24
38RDB4-VM	140D341G14	5CLS-5R	151D241G05	15CXI-7C	151D883G22	38DBA2-125E	18A7330G25
8RDB4-HVM	140D341G16	5CLS-6R	151D241G06	15CXI-15C	151D883G25	38DBA2-150E	18A7330G26
15RDB4-HVM	140D341G17	4CX-60C	151D253G06	15CXI-10C	151D883G31	38DBA2-200E	18A7330G27
25RDB4-HVM	140D341G18	4CX-80C	151D253G08	15CXI-3C	151D883g32	48DBA2-5E	18A7330G33
38RDB4-HVM	140D341G19	4CXI-60C	151D253G26	5CX-GNM-G	151D884G01	48DBA2-7E	18A7330G34
RDB4-VL	140D341G20	4CXI-80C	151D253G28	8CX-GNM-G	151D884G02	48DBA2-10E	18A7330G35
8RDB8-VM	140D342G11	5CX-25C	151D254G03	15CX-GNM-G	151D884G03	48DBA2-15E	18A7330G36
15RDB8-VM	140D342G12	5CX-21C	151D254G04	CX-NL	151D884G08	48DBA2-20E	18A7330G37
25RDB8-VM	140D342G13	5CX-35C	151D254G06	5CX-GDM-G	151D885G01	48DBA2-25E	18A7330G38
38RDB8-VM	140D342G14	5CX-60C	151D254G09	8CX-GDM-G	151D885G02	48DBA2-30E	18A7330G39
8RDB8-HVM	140D342G16	5CX-10C	151D254G11	15CX-GDM-G	151D885G03	48DBA2-40E	18A7330G40
15RDB8-HVM	140D342G17	5CX-12C	151D254G12	CX-DL	151D885G05	48DBA2-50E	18A7330G41
25RDB8-HVM	140D342G18	5CXI-25C	151D254G23	CX-DF	151D885G06	48DBA2-65E	18A7330G42
38RDB8-HVM	140D342G19	5CXI-21C	151D254G24	6DSL-C800	151D932G01	48DBA2-780E	18A7330G43

Appendix 3—Catalog Number/Style Number Cross Reference

Style Number	Catalog Number	Style Number	Catalog Number	Style Number	Catalog Number	Style Number	Catalog Number
48DBA2-100E	18A7330G44	25RDB4-DH	310C131G03	25RBA2-150E	423D814A56	25RBT2-30E	449D671A49
48DBA2-125E	18A7330G45	25RDB4-DH	310C131G03	25RBA2-175E	423D814A57	25RBT2-40E	449D671A50
48DBA2-150E	18A7330G46	38RDB4-DH	310C131G04	25RBA2-200E	423D814A58	25RBT2-50E	449D671A51
48DBA2-200E	18A7330G47	38RDB4-DH	310C131G04	38RBA2-10E	423D814A65	25RBT2-65E	449D671A52
38DBA2-5	22A6782G04	38RDB4-DH	310C131G04	38RBA2-15E	423D814A66	25RBT2-80E	449D671A53
48DBA2-5	22A6782G05	38RDB4-DH	310C131G04	38RBA2-20E	423D814A67	25RBT2-100E	449D671A54
72DBA2-5	22A6782G06	8BA4-NH	310C196G01	38RBA2-25E	423D814A68	25RBT2-125E	449D671A55
5LCLS-18R	304C463G03	15BA4-NH	310C196G02	38RBA2-30E	423D814A69	25RBT2-150E	449D671A56
5LCLS-24R	304C463G04	RBA2-COND	310C197G03	38RBA2-40E	423D814A70	25RBT2-200E	449D671A58
8RDB2-SHNT	308C548G01	RBA4-COND	310C197G04	38RBA2-50E	423D814A71	38RBT2-20E	449D671A67
15RDB2-SHNT	308C548G02	RBA2-COND-1	310C197G05	38RBA2-65E	423D814A72	38RBT2-25E	449D671A68
25RDB2-SHNT	308C548G03	RBA4-COND-1	310C197G06	38RBA2-80E	423D814A73	38RBT2-30E	449D671A69
38RDB2-SHNT	308C548G04	8BA2-NH	310C198G01	38RBA2-100E	423D814A74	38RBT2-40E	449D671A70
RBA2-COND	309C024G03	15BA2-NH	310C198G02	38RBA2-125E	423D814A75	38RBT2-50E	449D671A71
RBA2-FLTR	309C024G03	8RBA2-10E	423D814A05	38RBA2-150E	423D814A76	38RBT2-65E	449D671A72
RBA2-FLTR-1	309C024G03	8RBA2-15E	423D814A06	38RBA2-175E	423D814A77	38RBT2-80E	449D671A73
RBA4-COND	309C024G04	8RBA2-20E	423D814A07	38RBA2-200E	423D814A78	38RBT2-100E	449D671A74
RBA2-FLTR	309C024G05	8RBA2-25E	423D814A08	HANDLE ASSEMBLY	435B592G02	38RBT2-125E	449D671A75
Spring and shunt assy. for 8BA2-NH	309C054G01	8RBA2-30E	423D814A09	15CLE2-80E	439D482G04	38RBT2-150E	449D671A76
Spring and shunt assy. for 15BA2-NH	309C054G02	8RBA2-40E	423D814A10	15CLE2-100E	439D482G05	38RBT2-200E	449D671A78
8RBA2-ISHNT	309C548G09	8RBA2-50E	423D814A11	15CLE2-125X	439D482G06	2CLE-30E	449D797G02
15RBA2-ISHNT	309C548G10	8RBA2-65E	423D814A12	5CLE-750E	449D595G01	2CLE-50E	449D797G03
25RBA2-ISHNT	309C548G11	8RBA2-80E	423D814A13	5CLE-600E	449D595G02	2CLE-65E	449D797G04
38RBA2-ISHNT	309C548G12	8RBA2-100E	423D814A14	5ACLS-30	449D597G01	2CLE-80E	449D797G05
8RBA2-DH	309C558G01	8RBA2-125E	423D814A15	5ACLS-2R	449D597G02	2CLE-100E	449D797G06
8RBA2-DH	309C558G01	8RBA2-150E	423D814A16	5ACLS-3R	449D597G03	2CLE-125E	449D797G07
15RBA2-DH	309C558G02	8RBA2-175E	423D814A17	5ACLS-4R	449D597G04	2CLE-150E	449D797G08
15RBA2-DH	309C558G02	8RBA2-200E	423D814A18	5ACLS-5R	449D597G05	2CLE-200E	449D797G09
25RBA2-DH	309C558G03	15RBA2-10E	423D814A25	5ACLS-6R	449D597G06	2CLE-225E	449D797G10
38RBA2-DH	309C558G04	15RBA2-15E	423D814A26	8RBT2-20E	449D671A07	2CLE-10E	449D797G11
8RDB2-DH	309C558G05	15RBA2-20E	423D814A27	8RBT2-25E	449D671A08	2CLE-25E	449D797G12
8RDB2-DH	309C558G05	15RBA2-25E	423D814A28	8RBT2-30E	449D671A09	2CLE-250E	449D797G13
15RDB2-DH	309C558G06	15RBA2-30E	423D814A29	8RBT2-40E	449D671A10	2CLE-300E	449D797G14
15RDB2-DH	309C558G06	15RBA2-40E	423D814A30	8RBT2-50E	449D671A11	2CLE-350X	449D797G15
25RDB2-DH	309C558G07	15RBA2-50E	423D814A31	8RBT2-65E	449D671A12	2CLE-400X	449D797G17
25RDB2-DH	309C558G07	15RBA2-65E	423D814A32	8RBT2-80E	449D671A13	2CLE-450X	449D797G18
38RDB2-DH	309C558G08	15RBA2-80E	423D814A33	8RBT2-100E	449D671A14	38DBA2-3	505D420G07
38RDB2-DH	309C558G08	15RBA2-100E	423D814A34	8RBT2-125E	449D671A15	48DBA2-3	505D420G08
15RBA4-DH	309C797G02	15RBA2-125E	423D814A35	8RBT2-150E	449D671A16	72DBA2-3	505D420G09
15RBA4-DH	309C797G02	15RBA2-150E	423D814A36	8RBT2-200E	449D671A18	2ACLS-25	591C142G01
25RBA4-DH	309C797G03	15RBA2-175E	423D814A37	15RBT2-20E	449D671A27	2ACLS-2R	591C142G02
38RBA4-DH	309C797G04	15RBA2-200E	423D814A38	15RBT2-25E	449D671A28	2ACLS-3R	591C142G03
8RDB4-DH	310C131G01	25RBA2-10E	423D814A45	15RBT2-30E	449D671A29	2ACLS-4R	591C142G04
8RDB4-DH	310C131G01	25RBA2-15E	423D814A46	15RBT2-40E	449D671A30	2ACLS-5R	591C142G05
8RDB4-DH	310C131G01	25RBA2-20E	423D814A47	15RBT2-50E	449D671A31	2ACLS-6R	591C142G06
8RDB4-DH	310C131G01	25RBA2-25E	423D814A48	15RBT2-65E	449D671A32	2ACLS-9R	591C142G07
8RDB4-DH	310C131G01	25RBA2-30E	423D814A49	15RBT2-80E	449D671A33	2ACLS-12R	591C142G08
15RDB4-DH	310C131G02	25RBA2-40E	423D814A50	15RBT2-100E	449D671A34	2ACLS-18R	591C143G01
15RDB4-DH	310C131G02	25RBA2-50E	423D814A51	15RBT2-125E	449D671A35	2ACLS-24R	591C143G02
15RDB4-DH	310C131G02	25RBA2-65E	423D814A52	15RBT2-150E	449D671A36	2HCLS-25	591C155G01
15RDB4-DH	310C131G02	25RBA2-80E	423D814A53	15RBT2-200E	449D671A38	2HCLS-2R	591C155G02
25RDB4-DH	310C131G03	25RBA2-100E	423D814A54	25RBT2-20E	449D671A47	2HCLS-3R	591C155G03
25RDB4-DH	310C131G03	25RBA2-125E	423D814A55	25RBT2-25E	449D671A48	2HCLS-4R	591C155G04

Appendix 3—Catalog Number/Style Number Cross Reference

Style Number	Catalog Number	Style Number	Catalog Number	Style Number	Catalog Number	Style Number	Catalog Number
2HCLS-5R	591C155G05	5CXI-18C	5978C70G21	15DBA1-80E	5980C15G33	48DBA1-125E	5980C17G15
2HCLS-6R	591C155G06	5CXI-20C	5978C70G22	15DBA1-100E	5980C15G34	48DBA1-150E	5980C17G16
2HCLS-9R	591C155G07	5CXI-30C	5978C70G24	15DBA1-125E	5980C15G35	48DBA1-200E	5980C17G17
2HCLS-12R	591C155G08	5CXI-40C	5978C70G25	15DBA1-150E	5980C15G36	72DBA1-0.5	5980C17G21
2HCLS-18R	591C157G01	5CXI-50C	5978C70G26	15DBA1-200E	5980C15G37	72DBA1-3	5980C17G22
2HCLS-24R	591C157G02	5CXI-65C	5978C70G27	25DBA1-0.5	5980C16G01	72DBA1-5E	5980C17G23
CLS-700 DUMMY	591C172G01	5CXI-75C	5978C70G28	25DBA1-3	5980C16G02	72DBA1-7E	5980C17G24
8CLT-12C	591C273G03	8CX-18C	5978C72G01	25DBA1-5E	5980C16G03	72DBA1-10E	5980C17G25
15CLE3-175E/200X	591C376G01	8CX-20C	5978C72G02	25DBA1-7E	5980C16G04	72DBA1-15E	5980C17G26
15CLE3-150E	591C376G02	8CX-25C	5978C72G03	25DBA1-10E	5980C16G05	72DBA1-20E	5980C17G27
RBA4-FLTR	591C607G01	8CX-30C	5978C72G04	25DBA1-15E	5980C16G06	72DBA1-25E	5980C17G28
RBA4-FLTR-HC	591C607G02	8CX-40C	5978C72G05	25DBA1-20E	5980C16G07	72DBA1-30E	5980C17G29
RBA4-FLTR-1	591C607G03	8CXI-18C	5978C72G21	25DBA1-25E	5980C16G08	72DBA1-40E	5980C17G30
RBA4-FLTR-HC-1	591C607G04	8CXI-20C	5978C72G22	25DBA1-30E	5980C16G09	72DBA1-50E	5980C17G31
2CLS-25	591C812G01	8CXI-25C	5978C72G23	25DBA1-40E	5980C16G10	72DBA1-65E	5980C17G32
2CLS-2R	591C812G02	8CXI-30C	5978C72G24	25DBA1-50E	5980C16G11	72DBA1-80E	5980C17G33
2CLS-3R	591C812G03	8CXI-40C	5978C72G25	25DBA1-65E	5980C16G12	72DBA1-100E	5980C17G34
2CLS-4R	591C812G04	7CLS70-24R	5979C91G01	25DBA1-80E	5980C16G13	72DBA1-125E	5980C17G35
2CLS-5R	591C812G05	7CLS70-36R	5979C91G02	25DBA1-100E	5980C16G14	72DBA1-150E	5980C17G36
2CLS-6R	591C812G06	6DSL-E2500	5980C01G01	25DBA1-125E	5980C16G15	72DBA1-200E	5980C17G37
2CLS-9R	591C812G07	6DSL-E3000	5980C01G02	25DBA1-150E	5980C16G16	15CX-18C	5980C19G01
2CLS-12R	591C812G08	6DSL-E4000	5980C01G03	25DBA1-200E	5980C16G17	15CX-20C	5980C19G02
2CLS-18R	591C813G01	6DSL-F5000	5980C01G04	38DBA1-0.5	5980C16G21	15CX-25C	5980C19G03
2CLS-24R	591C813G02	7CLS70-44R	5980C03G01	38DBA1-3	5980C16G22	15CX-30C	5980C19G04
4CX-18C	5978C62G01	8DBA1-0.5	5980C15G01	38DBA1-5E	5980C16G23	15CX-40C	5980C19G05
4CX-25C	5978C62G02	8DBA1-3	5980C15G02	38DBA1-7E	5980C16G24	15CX-6C	5980C19G06
4CX-35C	5978C62G03	8DBA1-5E	5980C15G03	38DBA1-10E	5980C16G25	15CX-12C	5980C19G07
8CX-4.5C	5978C62G04	8DBA1-7E	5980C15G04	38DBA1-15E	5980C16G26	15CX-8C	5980C19G07
8CX-6C	5978C62G05	8DBA1-10E	5980C15G05	38DBA1-20E	5980C16G27	15CXI-18C	5980C19G21
8CX-8C	5978C62G06	8DBA1-15E	5980C15G06	38DBA1-25E	5980C16G28	15CXI-20C	5980C19G22
4CXI-18C	5978C62G21	8DBA1-20E	5980C15G07	38DBA1-30E	5980C16G29	15CXI-25C	5980C19G23
4CXI-25C	5978C62G22	8DBA1-25E	5980C15G08	38DBA1-40E	5980C16G30	15CXI-30C	5980C19G24
4CXI-35C	5978C62G23	8DBA1-30E	5980C15G09	38DBA1-50E	5980C16G31	15CXI-40C	5980C19G25
8CXI-4.5C	5978C62G24	8DBA1-40E	5980C15G10	38DBA1-65E	5980C16G32	15CXI-6C	5980C19G26
8CXI-6C	5978C62G25	8DBA1-50E	5980C15G11	38DBA1-80E	5980C16G33	15CXI-12C	5980C19G27
8CXI-8C	5978C62G26	8DBA1-65E	5980C15G12	38DBA1-100E	5980C16G34	5HLE-PDM-D	5981C03G01
4CX-45C	5978C66G01	8DBA1-80E	5980C15G13	38DBA1-125E	5980C16G35	8HLE-PDM-D	5981C03G02
4CX-50C	5978C66G02	8DBA1-100E	5980C15G14	38DBA1-150E	5980C16G36	15HLE-PDM-D	5981C03G03
4CX-65C	5978C66G03	8DBA1-125E	5980C15G15	48DBA1-0.5	5980C17G01	5HLE-GDM-D	5981C03G04
4CX-75C	5978C66G04	8DBA1-150E	5980C15G16	48DBA1-3	5980C17G02	8HLE-GDM-D	5981C03G05
4CX-100C	5978C66G05	8DBA1-200E	5980C15G17	48DBA1-5E	5980C17G03	15HLE-GDM-D	5981C03G06
4CXI-45C	5978C66G21	15DBA1-0.5	5980C15G21	48DBA1-7E	5980C17G04	5HLE-PNM-D	5981C03G07
4CXI-50C	5978C66G22	15DBA1-3	5980C15G22	48DBA1-10E	5980C17G05	8HLE-PNM-D	5981C03G08
4CXI-65C	5978C66G23	15DBA1-5E	5980C15G23	48DBA1-15E	5980C17G06	15HLE-PNM-D	5981C03G09
4CXI-75C	5978C66G24	15DBA1-7E	5980C15G24	48DBA1-20E	5980C17G07	5HLE-GNM-D	5981C03G10
4CXI-100C	5978C66G25	15DBA1-10E	5980C15G25	48DBA1-25E	5980C17G08	8HLE-GNM-D	5981C03G11
5CX-18C	5978C70G01	15DBA1-15E	5980C15G26	48DBA1-30E	5980C17G09	15HLE-GNM-D	5981C03G12
5CX-20C	5978C70G02	15DBA1-20E	5980C15G27	48DBA1-40E	5980C17G10	5HLE-PDM-E	5981C03G13
5CX-30C	5978C70G04	15DBA1-25E	5980C15G28	48DBA1-50E	5980C17G11	8HLE-GDM-E	5981C03G14
5CX-40C	5978C70G05	15DBA1-30E	5980C15G29	48DBA1-65E	5980C17G12	8HLE-PDM-E	5981C03G14
5CX-50C	5978C70G06	15DBA1-40E	5980C15G30	48DBA1-80E	5980C17G13	15HLE-PDM-E	5981C03G15
5CX-65C	5978C70G07	15DBA1-50E	5980C15G31	48DBA1-100E	5980C17G14	5HLE-GDM-E	5981C03G16
5CX-75C	5978C70G08	15DBA1-65E	5980C15G32				

Appendix 3—Catalog Number/Style Number Cross Reference

Style Number	Catalog Number	Style Number	Catalog Number	Style Number	Catalog Number	Style Number	Catalog Number
15HLE-GDM-E	5981C03G18	15HLE-100E	5981C18G09	15HLE-25E	5981C32G04	25RBA2-INH	5981C51G03
5HLE-PNM-E	5981C03G19	15HLE-125E	5981C18G10	15HLE-30E	5981C32G05	38RBA2-INH	5981C51G04
8HLE-PNM-E	5981C03G20	15CLE-40E	5981C19G04	15CLE-10E	5981C33G01	8RBA4-DH	5981C52G01
15HLE-PNM-E	5981C03G21	15CLE-50E	5981C19G05	15CLE-15E-D	5981C33G02	8RBA4-DH	5981C52G01
5HLE-GNM-E	5981C03G22	15CLE-65E	5981C19G06	15CLE-20E-D	5981C33G03	8RBA4-IDH	5981C52G01
8HLE-GNM-E	5981C03G23	15CLE-80E	5981C19G07	15CLE-25E-D	5981C33G04	8RBA4-IDH	5981C52G01
15HLE-GNM-E	5981C03G24	15CLE-100E	5981C19G08	15CLE-30E	5981C33G05	15RBA4-IDH	5981C52G02
5NCLPT-10E-A	5981C05G01	15CLE-125E	5981C19G09	5AHLE-10E	5981C46G01	15RBA4-IDH	5981C52G02
5NCLPT-5E-A	5981C05G02	15CLE-150E	5981C19G10	5AHLE-15E	5981C46G02	25RBA4-IDH	5981C52G03
5NCLPT-3E-A	5981C05G03	8CLE-200E	5981C21G01	5AHLE-20E	5981C46G03	38RBA4-IDH	5981C52G04
5NCLPT-2E-A	5981C05G04	8CLE-250E	5981C21G02	5AHLE-25E	5981C46G04	8RBA4-INH	5981C53G01
5NCLPT-1E-A	5981C05G05	8CLE-300E	5981C21G03	5AHLE-30E	5981C46G05	8RBA4-INH	5981C53G01
5NCLPT-0.5E-A	5981C05G06	8CLE-350E	5981C21G04	5AHLE-40E	5981C46G06	15RBA4-INH	5981C53G02
8NCLPT-10E-B	5981C06G01	8HLE-200E	5981C22G01	5AHLE-50E	5981C46G07	15RBA4-INH	5981C53G02
8NCLPT-5E-B	5981C06G02	8HLE-250E	5981C22G02	5AHLE-65E	5981C46G08	25RBA4-INH	5981C53G03
8NCLPT-3E-B	5981C06G03	8HLE-300E	5981C22G03	5AHLE-80E	5981C46G09	38RBA4-INH	5981C53G04
8NCLPT-2E-A	5981C06G04	8HLE-350E	5981C22G04	5AHLE-100E	5981C46G10	8RBA8-INH	5981C54G01
8NCLPT-1E-A	5981C06G05	15HLE-150E	5981C24G01	5AHLE-125E	5981C46G11	8RBA8-INH	5981C54G01
8NCLPT-0.5E-A	5981C06G06	15HLE-175E	5981C24G02	5AHLE-150E	5981C46G12	15RBA8-INH	5981C54G02
15NCLPT-10E-B	5981C07G01	15HLE-200E	5981C24G03	5AHLE-175E	5981C46G13	15RBA8-INH	5981C54G02
15NCLPT-5E-B	5981C07G02	15HLE-250E	5981C24G04	5AHLE-200E	5981C46G14	25RBA8-INH	5981C54G03
15NCLPT-3E-B	5981C07G03	15CLE-175E	5981C25G01	5AHLE-250E	5981C46G15	38RBA8-INH	5981C54G04
15NCLPT-20.5E-A	5981C07G04	15CLE-200E	5981C25G02	5AHLE-300E	5981C46G16	5BHCL-750E	5981C58G01
15NCLPT-1E-A	5981C07G05	15CLE-250E	5981C25G03	5AHLE-350E	5981C46G17	5BHCL-900E	5981C58G02
15NCLPT-0.5E-A	5981C07G06	15CLE-300E	5981C25G04	5AHLE-400E	5981C46G18	15HCL-250E	5981C61G01
8HLE-40E	5981C16G04	5HLE-10E	5981C28G01	5AHLE-450E	5981C46G19	15HCL-300E	5981C61G02
8HLE-50E	5981C16G05	5HLE-15E	5981C28G02	8AHLE-10E	5981C47G01	15HCL-200E	5981C61G03
8HLE-65E	5981C16G06	5HLE-20E	5981C28G03	8AHLE-15E	5981C47G02	15HCL-150E	5981C61G04
8HLE-80E	5981C16G07	5HLE-25E	5981C28G04	8AHLE-20E	5981C47G03	5HCL-500E	5981C62G01
8HLE-100E	5981C16G08	5HLE-30E	5981C28G05	8AHLE-25E	5981C47G04	5HCL-600E	5981C62G02
8HLE-125E	5981C16G09	5CLE-10E-D	5981C29G01	8AHLE-30E	5981C47G05	5HCL-450E	5981C62G03
8HLE-150E	5981C16G10	5HCL-10E	5981C29G01	8AHLE-40E	5981C47G06	5HCL-400E	5981C62G04
8HLE-175E	5981C16G11	5CLE-15E-D	5981C29G02	8AHLE-50E	5981C47G07	5HCL-300E	5981C62G05
15RBA4-INH-B	5981C17G02	5HCL-15E	5981C29G02	8AHLE-65E	5981C47G08	5HCL-250E	5981C62G06
15RBA4-INH-B	5981C17G02	5CLE-20E-D	5981C29G03	8AHLE-80E	5981C47G09	5HCL-200E	5981C62G07
25RBA4-INH-B	5981C17G03	5HCL-20E	5981C29G03	8AHLE-100E	5981C47G10	5BHCL-600E	5981C62G08
38RBA4-INH-B	5981C17G04	5CLE-25E-D	5981C29G04	8AHLE-125E	5981C47G11	5BHCL-500E	5981C62G09
8CLE-40E	5981C17G04	5HCL-25E	5981C29G04	8AHLE-150E	5981C47G12	5BHCL-450E	5981C62G10
8CLE-50E	5981C17G05	5CLE-30E	5981C29G05	8AHLE-175E	5981C47G13	5HLE-40E	5981C64G01
8CLE-65E	5981C17G06	5HCL-30E	5981C29G05	8AHLE-200E	5981C47G14	5HLE-50E	5981C64G02
8CLE-80E	5981C17G07	8HLE-10E	5981C30G01	8AHLE-250E	5981C47G15	5HLE-65E	5981C64G03
8CLE-100E	5981C17G08	8HLE-15E	5981C30G02	8AHLE-300E	5981C47G16	5HLE-80E	5981C64G04
8CLE-125E	5981C17G09	8HLE-20E	5981C30G03	8AHLE-350E	5981C47G17	5HLE-100E	5981C64G05
8CLE-150E	5981C17G10	8HLE-25E	5981C30G04	8RBA2-IDH	5981C50G01	5HLE-125E	5981C64G06
8CLE-175E	5981C17G11	8HLE-30E	5981C30G05	8RBA2-IDH	5981C50G01	5HLE-150E	5981C64G07
15RBA2-INH-B	5981C18G02	8CLE-10E	5981C31G01	15RBA2-IDH	5981C50G02	5HLE-175E	5981C64G08
15RBA2-INH-B	5981C18G02	8CLE-15E-D	5981C31G02	25RBA2-IDH	5981C50G03	5HLE-200E	5981C64G09
25RBA2-INH-B	5981C18G03	8CLE-20E-D	5981C31G03	38RBA2-IDH	5981C50G04	5HLE-250E	5981C64G10
38RBA2-INH-B	5981C18G04	8CLE-25E-D	5981C31G04	8RBA2-INH	5981C51G01	5CLE-40E	5981C65G01
15HLE-40E	5981C18G05	8CLE-30E	5981C31G05	8RBA2-INH	5981C51G01	5CLE-50E	5981C65G02
15HLE-50E	5981C18G06	15HLE-10E	5981C32G01	15RBA2-INH	5981C51G02	5CLE-65E	5981C65G03
15HLE-65E	5981C18G07	15HLE-15E	5981C32G02	15RBA2-INH	5981C51G02	5CLE-80E	5981C65G04
15HLE-80E	5981C18G08	15HLE-20E	5981C32G03				

Appendix 3—Catalog Number/Style Number Cross Reference

Style Number	Catalog Number
5CLE-100E	5981C65G05
5CLE-125E	5981C65G06
5HCL-40E	5981C65G06
5CLE-150E	5981C65G07
5HCL-50E	5981C65G07
5CLE-175E	5981C65G08
5HCL-65E	5981C65G08
5CLE-200E	5981C65G09
5HCL-80E	5981C65G09
5CLE-250E	5981C65G10
5HCL-100E	5981C65G10
5HCL-125E	5981C65G11
5HCL-150E	5981C65G12
5HLE-300E	5981C66G01
5HLE-350E	5981C66G02
5HLE-400E	5981C66G03
5HLE-450E	5981C66G04
5CLE-300E	5981C67G01
5CLE-350E	5981C67G02
5CLE-400E	5981C67G03
5CLE-450E	5981C67G04
15HCL-65E	5981C68G04
15HCL-80E	5981C68G05
15HCL-100E	5981C68G06
15HCL-125E	5981C68G07
DBU-MFLR	5981C69G02
DBU17-3K	5981C75G01
DBU27-3K	5981C75G01
DBU38-3K	5981C75G01
DBU17-6K	5981C75G02
DBU27-6K	5981C75G02
DBU38-6K	5981C75G02
DBU1780K	5981C75G03
DBU27-8K	5981C75G03
DBU38-8K	5981C75G03
DBU17-10K	5981C75G04
DBU27-10K	5981C75G04
DBU38-10K	5981C75G04
DBU17-12K	5981C75G05
DBU27-12K	5981C75G05
DBU38-12K	5981C75G05
DBU17-15K	5981C75G06
DBU27-15K	5981C75G06
DBU38-15K	5981C75G06
DBU17-20K	5981C75G07
DBU27-20K	5981C75G07
DBU38-20K	5981C75G07
DBU17-25K	5981C75G08
DBU27-25K	5981C75G08
DBU38-25K	5981C75G08
DBU17-30K	5981C75G09
DBU27-30K	5981C75G09
DBU38-30K	5981C75G09

Style Number	Catalog Number
DBU17-40K	5981C75G10
DBU27-40K	5981C75G10
DBU38-40K	5981C75G10
DBU17-50K	5981C75G11
DBU27-50K	5981C75G11
DBU38-50K	5981C75G11
DBU17-65K	5981C75G12
DBU27-65K	5981C75G12
DBU38-65K	5981C75G12
DBU17-80K	5981C75G13
DBU27-80K	5981C75G13
DBU38-80K	5981C75G13
DBU17-100K	5981C75G14
DBU27-100K	5981C75G14
DBU38-100K	5981C75G14
DBU17-140K	5981C75G15
DBU27-140K	5981C75G15
DBU38-140K	5981C75G15
DBU17-200K	5981C75G16
DBU27-200K	5981C75G16
DBU38-200K	5981C75G16
DBU17-5E	5981C76G01
DBU27-5E	5981C76G01
DBU38-5E	5981C76G01
DBU17-7E	5981C76G02
DBU27-7E	5981C76G02
DBU38-7E	5981C76G02
DBU17-10E	5981C76G03
DBU27-10E	5981C76G03
DBU38-10E	5981C76G03
DBU17-13E	5981C76G04
DBU27-13E	5981C76G04
DBU38-13E	5981C76G04
DBU17-15E	5981C76G05
DBU27-15E	5981C76G05
DBU38-15E	5981C76G05
DBU17-20E	5981C76G06
DBU27-20E	5981C76G06
DBU38-20E	5981C76G06
DBU17-25E	5981C76G07
DBU27-25E	5981C76G07
DBU38-25E	5981C76G07
DBU17-30E	5981C76G08
DBU27-30E	5981C76G08
DBU38-30E	5981C76G08
DBU17-40E	5981C76G09
DBU27-40E	5981C76G09
DBU38-40E	5981C76G09
DBU17-50E	5981C76G10
DBU27-50E	5981C76G10
DBU38-50E	5981C76G10
DBU17-65E	5981C76G11
DBU27-65E	5981C76G11

Style Number	Catalog Number
DBU38-65E	5981C76G11
DBU17-80E	5981C76G12
DBU27-80E	5981C76G12
DBU38-80E	5981C76G12
DBU17-100E	5981C76G13
DBU27-100E	5981C76G13
DBU38-100E	5981C76G13
DBU17-125E	5981C76G14
DBU27-125E	5981C76G14
DBU38-125E	5981C76G14
DBU17-150E	5981C76G15
DBU27-150E	5981C76G15
DBU38-150E	5981C76G15
DBU17-175E	5981C76G16
DBU27-175E	5981C76G16
DBU38-175E	5981C76G16
DBU17-200E	5981C76G17
DBU27-200E	5981C76G17
DBU38-200E	5981C76G17
DBU17-15SE	5981C77G01
DBU27-15SE	5981C77G01
DBU38-15SE	5981C77G01
DBU17-20SE	5981C77G02
DBU27-20SE	5981C77G02
DBU38-20SE	5981C77G02
DBU17-25SE	5981C77G03
DBU27-25SE	5981C77G03
DBU38-25SE	5981C77G03
DBU17-30SE	5981C77G04
DBU27-30SE	5981C77G04
DBU38-30SE	5981C77G04
DBU17-40SE	5981C77G05
DBU27-40SE	5981C77G05
DBU38-40SE	5981C77G05
DBU17-50SE	5981C77G06
DBU27-50SE	5981C77G06
DBU38-50SE	5981C77G06
DBU17-65SE	5981C77G07
DBU27-65SE	5981C77G07
DBU38-65SE	5981C77G07
DBU17-80SE	5981C77G08
DBU27-80SE	5981C77G08
DBU38-80SE	5981C77G08
DBU17-100SE	5981C77G09
DBU27-100SE	5981C77G09
DBU38-100SE	5981C77G09
DBU17-125SE	5981C77G10
DBU27-125SE	5981C77G10
DBU38-125SE	5981C77G10
DBU17-150SE	5981C77G11
DBU27-150SE	5981C77G11
DBU38-150SE	5981C77G11
DBU17-175SE	5981C77G12

Style Number	Catalog Number
DBU27-175SE	5981C77G12
DBU38-175SE	5981C77G12
DBU17-200SE	5981C77G13
DBU27-200SE	5981C77G13
DBU38-200SE	5981C77G13
5CLS70-9R	5981C81G01
5CLS70-5R	5981C81G03
5CLS70-4R	5981C81G04
5CLS70-3R	5981C81G05
5CLS70-2R	5981C81G06
5CLS70-6R	5981C81G12
8CLS-2R	5982C01G01
8CLS-3R	5982C01G02
8CLS-4R	5982C01G03
8CLS-5R	5982C01G04
8CLS-6R	5982C01G05
7CLS-9R	5982C01G06
7CLS-12R	5982C01G07
7CLS-18R	5982C01G10
7CLS-24R	5982C01G11
HCL-NL	5982C19G04
5BCLS-30	5982C31G01
5BCLS-2R	5982C31G02
5BCLS-3R	5982C31G03
5BCLS-4R	5982C31G04
5BCLS-5R	5982C31G05
5BCLS-6R	5982C31G06
5BCLS-9R	5982C31G07
5BCLS-12R	5982C31G08
5BCLS-18R	5982C32G01
5BCLS-24R	5982C32G02
4BCLS-26R	5982C32G03
15HCL-10E	5982C34G01
15HCL-15E	5982C34G02
15HCL-20E	5982C34G03
15HCL-25E	5982C34G04
15HCL-30E	5982C34G05
15HCL-40E	5982C34G06
15HCL-50E	5982C34G07
7BCLS-2R	5982C36G01
7BCLS-3R	5982C36G02
7BCLS-4R	5982C36G03
7BCLS-5R	5982C36G04
7BCLS-6R	5982C36G05
7BCLS-9R	5982C36G06
7BCLS-12R	5982C36G07
7BCLS-18R	5982C36G08
7BCLS-24R	5982C36G09
8RBA4-5	5982C44A01
8RBA4-3	5982C44A02
8RBA4-5E	5982C44A03
8RBA4-7E	5982C44A04
8RBA4-10E	5982C44A05

Appendix 3—Catalog Number/Style Number Cross Reference

Style Number	Catalog Number	Style Number	Catalog Number	Style Number	Catalog Number	Style Number	Catalog Number
8RBA4-15E	5982C44A06	25RBA4-175E	5982C44A67	8RBT4-250E	5982C49A19	6MDSL-MB1600	5982C91G02
8RBA4-20E	5982C44A07	25RBA4-200E	5982C44A68	8RBT4-300E	5982C49A20	6MDSL-MB2000	5982C91G03
8RBA4-25E	5982C44A08	25RBA4-250E	5982C44A69	8RBT4-400E	5982C49A22	6MDSL-MC800	5982C92G01
8RBA4-30E	5982C44A09	25RBA4-300E	5982C44A70	15RBT4-20E	5982C49A32	6MDSL-MC1000	5982C92G02
8RBA4-40E	5982C44A10	38RBA4-5	5982C44A76	15RBT4-25E	5982C49A33	6MDSL-MC1200	5982C92G03
8RBA4-50E	5982C44A11	38RBA4-3	5982C44A77	15RBT4-30E	5982C49A34	6MDSL-MC1600	5982C92G04
8RBA4-65E	5982C44A12	38RBA4-5E	5982C44A78	15RBT4-40E	5982C49A35	6MDSL-MC2000	5982C92G05
8RBA4-80E	5982C44A13	38RBA4-7E	5982C44A79	15RBT4-50E	5982C49A36	6MDSL-MD2500	5982C93G01
8RBA4-100E	5982C44A14	38RBA4-10E	5982C44A80	15RBT4-65E	5982C49A37	6MDSL-MD3000	5982C93G02
8RBA4-125E	5982C44A15	38RBA4-15E	5982C44A81	15RBT4-80E	5982C49A38	5BHLE-10E	5983C02G01
8RBA4-150E	5982C44A16	38RBA4-20E	5982C44A82	15RBT4-100E	5982C49A39	5BHLE-15E	5983C02G02
8RBA4-175E	5982C44A17	38RBA4-25E	5982C44A83	15RBT4-125E	5982C49A40	5BHLE-20E	5983C02G03
8RBA4-200E	5982C44A18	38RBA4-30E	5982C44A84	15RBT4-150E	5982C49A41	5BHLE-25E	5983C02G04
8RBA4-250E	5982C44A19	38RBA4-40E	5982C44A85	15RBT4-200E	5982C49A43	5BHLE-30E	5983C02G05
8RBA4-300E	5982C44A20	38RBA4-50E	5982C44A86	15RBT4-250E	5982C49A44	5BHLE-40E	5983C02G06
8RBA4-400E	5982C44A22	38RBA4-65E	5982C44A87	15RBT4-300E	5982C49A45	5BHLE-50E	5983C02G07
15RBA4-5	5982C44A26	38RBA4-80E	5982C44A88	15RBT4-400E	5982C49A47	5BHLE-65E	5983C02G08
15RBA4-3	5982C44A27	38RBA4-100E	5982C44A89	25RBT4-20E	5982C49A57	5BHLE-80E	5983C02G09
15RBA4-5E	5982C44A28	38RBA4-125E	5982C44A90	25RBT4-25E	5982C49A58	5BHLE-100E	5983C02G10
15RBA4-7E	5982C44A29	38RBA4-150E	5982C44A91	25RBT4-30E	5982C49A59	5BHLE-125E	5983C02G11
15RBA4-10E	5982C44A30	38RBA4-175E	5982C44A92	25RBT4-40E	5982C49A60	5BHLE-150E	5983C02G12
15RBA4-15E	5982C44A31	38RBA4-200E	5982C44A93	25RBT4-50E	5982C49A61	5BHLE-175E	5983C02G13
15RBA4-20E	5982C44A32	38RBA4-250E	5982C44A94	25RBT4-65E	5982C49A62	5BHLE-200E	5983C02G14
15RBA4-25E	5982C44A33	38RBA4-300E	5982C44A95	25RBT4-80E	5982C49A63	5BHLE-250E	5983C02G15
15RBA4-30E	5982C44A34	DBU27-GDM-L	5982C45G05	25RBT4-100E	5982C49A64	5BHLE-300E	5983C02G16
15RBA4-40E	5982C44A35	DBU27-GDM-R	5982C45G06	25RBT4-125E	5982C49A65	5BHLE-350E	5983C02G17
15RBA4-50E	5982C44A36	DBU17-GDM-R	5982C45G07	25RBT4-150E	5982C49A66	5BHLE-400E	5983C02G18
15RBA4-65E	5982C44A37	DBU17-GDM-L	5982C45G08	25RBT4-200E	5982C49A68	5BHLE-450E	5983C02G19
15RBA4-80E	5982C44A38	2BCLS-25	5982C47G01	25RBT4-250E	5982C49A69	8BHLE-10E	5983C03G01
15RBA4-100E	5982C44A39	2BCLS-2R	5982C47G02	25RBT4-300E	5982C49A70	8BHLE-15E	5983C03G02
15RBA4-125E	5982C44A40	2BCLS-3R	5982C47G03	38RBT4-20E	5982C49A82	8BHLE-20E	5983C03G03
15RBA4-150E	5982C44A41	2BCLS-4R	5982C47G04	38RBT4-25E	5982C49A83	8BHLE-25E	5983C03G04
15RBA4-175E	5982C44A42	2BCLS-5R	5982C47G05	38RBT4-30E	5982C49A84	8BHLE-30E	5983C03G05
15RBA4-200E	5982C44A43	2BCLS-6R	5982C47G06	38RBT4-40E	5982C49A85	8BHLE-40E	5983C03G06
15RBA4-250E	5982C44A44	2BCLS-9R	5982C47G07	38RBT4-50E	5982C49A86	8BHLE-50E	5983C03G07
15RBA4-300E	5982C44A45	2BCLS-12R	5982C47G08	38RBT4-65E	5982C49A87	8BHLE-65E	5983C03G08
15RBA4-400E	5982C44A47	2BCLS-18R	5982C47G09	38RBT4-80E	5982C49A88	8BHLE-80E	5983C03G09
25RBA4-5	5982C44A51	2BCLS-24R	5982C47G10	38RBT4-100E	5982C49A89	8BHLE-100E	5983C03G10
25RBA4-3	5982C44A52	DBU17-DL-L	5982C48G02	38RBT4-125E	5982C49A90	8BHLE-125E	5983C03G11
25RBA4-5E	5982C44A53	DBU17-DL-R	5982C48G03	38RBT4-150E	5982C49A91	8BHLE-150E	5983C03G12
25RBA4-7E	5982C44A54	DBU27-DL-L	5982C48G05	38RBT4-200E	5982C49A93	8BHLE-175E	5983C03G13
25RBA4-10E	5982C44A55	DBU27-DL-R	5982C48G06	38RBT4-250E	5982C49A94	8BHLE-200E	5983C03G14
25RBA4-15E	5982C44A56	8RBT4-20E	5982C49A07	38RBT4-300E	5982C49A95	8BHLE-250E	5983C03G15
25RBA4-20E	5982C44A57	8RBT4-25E	5982C49A08	4NPL-3500	5982C64G01	8BHLE-300E	5983C03G16
25RBA4-25E	5982C44A58	8RBT4-30E	5982C49A09	4NPL-5000	5982C64G02	8BHLE-350E	5983C03G17
25RBA4-30E	5982C44A59	8RBT4-40E	5982C49A10	6MDSL-MA150	5982C90G01	8HCL-200E	5983C05G01
25RBA4-40E	5982C44A60	8RBT4-50E	5982C49A11	6MDSL-MA200	5982C90G02	8HCL-250E	5983C05G02
25RBA4-50E	5982C44A61	8RBT4-65E	5982C49A12	6MDSL-MA250	5982C90G03	8HCL-300E	5983C05G03
25RBA4-65E	5982C44A62	8RBT4-80E	5982C49A13	6MDSL-MA300	5982C90G04	8HCL-350E	5983C05G04
25RBA4-80E	5982C44A63	8RBT4-100E	5982C49A14	6MDSL-MA400	5982C90G05	8HCL-175E	5983C05G05
25RBA4-100E	5982C44A64	8RBT4-125E	5982C49A15	6MDSL-MA600	5982C90G07	8HCL-150E	5983C05G06
25RBA4-125E	5982C44A65	8RBT4-150E	5982C49A16	6MDSL-MA800	5982C90G08	8HCL-125E	5983C05G07
25RBA4-150E	5982C44A66	8RBT4-200E	5982C49A18	6MDSL-MB1200	5982C91G01	8HCL-100E	5983C05G08

Appendix 3—Catalog Number/Style Number Cross Reference

Style Number	Catalog Number
8HCL-80E	5983C05G09
8HCL-65E	5983C05G10
15BHLE-10E	5984C05G01
15BHLE-15E	5984C05G02
15BHLE-20E	5984C05G03
15BHLE-25E	5984C05G04
15BHLE-30E	5984C05G05
15BHLE-40E	5984C05G06
15BHLE-50E	5984C05G07
15BHLE-65E	5984C05G08
15BHLE-80E	5984C05G09
15BHLE-100E	5984C05G10
15BHLE-125E	5984C05G11
15BHLE-150E	5984C05G12
15BHLE-175E	5984C05G13
15BHLE-200E	5984C05G14
15BHLE-250E	5984C05G15
15BHLE2-40E	5984C05G16
15BHLE2-50E	5984C05G17
15BHLE2-65E	5984C05G18
15BHLE2-80E	5984C05G19
15BHLE2-100E	5984C05G20
15BHLE2-125E	5984C05G21
8RBA4-INH-B	5984C17G01
8RBA4-INH-B	5984C17G01
8RBA2-INH-B	5984C18G01
8RBA2-INH-B	5984C18G01
DBU17-GNMP-L	5984C25G01
DBU27-GNMP-L	5984C25G02
DBU38-GNMP-L	5984C25G03
DBU17-GNMP-R	5984C25G04
DBU27-GNMP-R	5984C25G05
DBU38-GNMP-R	5984C25G06
DBU17-GNM-L	5984C25G07
DBU27-GNM-L	5984C25G08
DBU38-GNM-L	5984C25G09
DBU17-GNM-R	5984C25G10
DBU27-GNM-R	5984C25G11
DBU38-GNM-R	5984C25G12
DBU17-NL-L	5984C29G01
DBU27-NL-L	5984C29G02
DBU38-NL-L	5984C29G03
DBU17-NL-R	5984C29G04
DBU27-NL-R	5984C29G05
DBU38-NL-R	5984C29G06
DBU17-NLP-L	5984C29G07
DBU27-NLP-L	5984C29G08
DBU38-NLP-L	5984C29G09
DBU17-NLP-R	5984C29G10
DBU27-NLP-R	5984C29G11
DBU38-NLP-R	5984C29G12
DBU27-DM	5984C38G01
DBU17-DM	5984C39G01

Style Number	Catalog Number
15LHLE-65E	5984C65G01
15LHLE-80E	5984C65G02
15LHLE-100E	5984C65G03
15LHLE2-125E	5984C65G04
15LHLE2-150E	5984C65G05
15LHLE-175E	5984C65G06
15LHLE-200E	5984C65G07
15LHLE-125E	5984C65G08
15LHLE-150E	5984C65G09
15LHLE-250E	5984C65G10
15LHLE-300E	5984C65G11
5LCLS-2R	676C546G15
5LCLS-3R	676C546G16
5LCLS-4R	676C546G17
5LCLS-5R	676C546G18
5LCLS-6R	676C546G19
5LCLS-9R	676C546G22
5LCLS-12R	676C546G25
Spring and shunt assy. for 8BA4-NH	676C878G01
Spring and shunt assy. for 15BA4-NH	676C878G02
25RBA2-NH	676C880G03
8RBA2-NH	677C370G01
8RBA2-NH	677C370G01
15RBA2-NH	677C370G02
15RBA2-NH	677C370G02
38RBA2-NH	677C370G04
8RBA4-NH	677C371G01
8RBA4-NH	677C371G01
15RBA4-NH	677C371G02
15RBA4-NH	677C371G02
25RBA4-NH	677C371G03
38RBA4-NH	677C371G04
2CLE-15E	678C240G01
2CLE-20E	678C240G02
2CLE-25E	678C240G03
5CLE-15E	678C240G04
5CLE-20E	678C240G05
5CLE-25E	678C240G06
8CLE-15E	678C240G07
8CLE-20E	678C240G08
8CLE-25E	678C240G09
15CLE-15E	678C240G10
15CLE-20E	678C240G11
15CLE-25E	678C240G12
2CLT-5C	678C248G01
8CLT-5C	678C248G03
5CLT-8C	678C248G05
8CLT-8C	678C248G06
2CLT-12C	678C249G01
5CLT-12C	678C249G02
2CLT-18C	678C276G01
5CLT-18C	678C276G02

Style Number	Catalog Number
8CLT-18C	678C276G03
2CLT-25C	678C276G04
5CLT-25C	678C276G05
8CLT-25C	678C276G06
2CLT-30C	678C277G04
2CLT-75C	678C282G01
8RBA4-ISHNT	678C283G05
8RBA4-ISHNT	678C283G05
15RBA4-ISHNT	678C283G06
15RBA4-ISHNT	678C283G06
25RBA4-ISHNT	678C283G07
25RBA4-ISHNT	678C283G07
38RBA4-ISHNT	678C283G08
38RBA4-ISHNT	678C283G08
8RDB4-SHNT	678C284G01
8RDB4-SHNT	678C284G01
15RDB4-SHNT	678C284G02
15RDB4-SHNT	678C284G02
25RDB4-SHNT	678C284G03
25RDB4-SHNT	678C284G03
38RDB4-SHNT	678C284G04
38RDB4-SHNT	678C284G04
8CLT-30CL	678C290G01
15CLT-12C	678C295G02
15CLT-8C	678C295G03
15CLT-5C	678C295G04
15CLT-4C	678C295G05
15CLT-18C	678C295G07
8CLT-30CS	680C386G01
5CLT-30C	680C386G02
5CLT-60C	680C386G03
5CLT-45C	680C386G05
8CLT-45C	680C386G06
2CLT-150C	680C387G01
2CLT-90C	680C387G02
DBU-EFOD	7187A11G02
DBU-EFID	7187A11G04
CXN-CLAMP	7275A85G02
5RBA4-PDM	9078A19G01
5RBA4-PDM	9078A19G01
5RBA4-GDM	9078A19G02
5RBA4-GDM	9078A19G02
14RBA4-PDM	9078A19G03
14RBA4-PDM	9078A19G03
14RBA4-GDM	9078A19G04
14RBA4-GDM	9078A19G04
15RBA4-PDM	9078A19G05
15RBA4-PDM	9078A19G05
25RBA4-PDM	9078A19G06
25RBA4-PDM	9078A19G06
38RBA4-PDM	9078A19G07
38RBA4-PDM	9078A19G07
15RBA4-DL	9078A20A01

Style Number	Catalog Number
15RBA4-DL	9078A20A01
15RBA4-DL	9078A20A01
15RBA4-DL	9078A20A01
15RBA4-DL	9078A20A01
15RBA4-DL	9078A20A01
15RBA4-DL	9078A20A01
15RBA4-DL	9078A20A01
38RBA4-DL	9078A20A02
5RBA2-PDM	9078A25G01
5RBA2-PDM	9078A25G01
5RBA2-GDM	9078A25G02
5RBA2-GDM	9078A25G02
14RBA2-PDM	9078A25G03
14RBA2-PDM	9078A25G03
14RBA2-GDM	9078A25G04
14RBA2-GDM	9078A25G04
15RBA2-PDM	9078A25G05
15RBA2-PDM	9078A25G05
25RBA2-PDM	9078A25G06
25RBA2-PDM	9078A25G06
38RBA2-PDM	9078A25G07
38RBA2-PDM	9078A25G07
8RBA2-PDM	9078A25G08
8RBA2-PDM	9078A25G08
8RBA4-PDM	9078A25G08
8RBA4-PDM	9078A25G08
8RBA2-GDM	9078A25G09
8RBA2-GDM	9078A25G09
8RBA4-GDM	9078A25G09
8RBA4-GDM	9078A25G09
15RBA2-DL	9078A26A01
15RBA2-DL	9078A26A01
15RBA2-DL	9078A26A01
15RBA2-DL	9078A26A01
15RBA2-DL	9078A26A01
15RBA2-DL	9078A26A01
15RBA2-DL	9078A26A01
15RBA2-DL	9078A26A01
38RBA2-DL	9078A26A02
38RBA2-DL	9078A26A02
38RBA2-DL	9078A26A02
38RBA2-DL	9078A26A02
15RBA2-NL	9078A30A01
15RBA2-NL	9078A30A01
15RBA2-NL	9078A30A01
15RBA2-NL	9078A30A01
15RBA2-NL	9078A30A01
15RBA2-NL	9078A30A01
15RBA2-NL	9078A30A01
38RBA2-NL	9078A30A02
38RBA2-NL	9078A30A02
38RBA2-NL	9078A30A02

Appendix 3—Catalog Number/Style Number Cross Reference

Style Number	Catalog Number	Style Number	Catalog Number	Style Number	Catalog Number	Style Number	Catalog Number
38RBA2-NL	9078A30A02	5RBA2-GNM	9078A33G16	5CLE-GDM-C	9078A65G31	15CXN-GNM-G	9570D05G02
15RBA4-NL	9078A30A03	8RBA2-GNM	9078A33G17	8CLE-GDM-C	9078A65G32	15CXN-NL-G	9570D05G06
15RBA4-NL	9078A30A03	8RBA2-GNM	9078A33G17	15CLE-GDM-C	9078A65G33	15CXN-GDM-G	9570D06G01
15RBA4-NL	9078A30A03	8RBA4-GNM	9078A33G17	2CLE-GDM-D	9078A65G34	15CXN-DL-G	9570D06G03
15RBA4-NL	9078A30A03	8RBA4-GNM	9078A33G17	5CLE-GDM-D	9078A65G35	15CXN-DF-G	9570D06G05
15RBA4-NL	9078A30A03	14RBA2-GNM	9078A33G18	8CLE-GDM-D	9078A65G36	15CLT-30C	9570D10G01
15RBA4-NL	9078A30A03	14RBA2-GNM	9078A33G18	15CLE-GDM-D	9078A65G37	15CXN-GNM-F	9570D33G01
15RBA4-NL	9078A30A03	5RBA4-GNM	9078A33G19	2CLE-GDM-E	9078A65G38	15CXN-NL-F	9570D33G02
15RBA4-NL	9078A30A03	5RBA4-GNM	9078A33G19	5CLE-GDM-E	9078A65G39	15CXN-GNM-D	9570D33G03
38RBA4-NL	9078A30A04	14RBA4-GNM	9078A33G21	8CLE-GDM-E	9078A65G40	15CXN-NL-D	9570D33G04
38RBA4-NL	9078A30A04	14RBA4-GNM	9078A33G21	CLE-NL-C	9078A67G02	15CXN-GDM-F	9570D34G01
15RBA8-NL	9078A30A05	5RBA8-GNM	9078A33G22	CLE-DL-D	9078A67G03	15CXN-DL-F	9570D34G02
15RBA8-NL	9078A30A05	5RBA8-GNM	9078A33G22	CLE-NL-D	9078A67G03	5BCLS-32R	9570D64G01
15RBA8-NL	9078A30A05	5RBA8-GNM	9078A33G22	CLE-NL-E	9078A67G04	5BCLS-36R	9570D64G02
15RBA8-NL	9078A30A05	5RBA8-PNM	9078A33G22	CLE-NLC-E	9078A67G15	5BCLS-44R	9570D64G03
15RBA8-NL	9078A30A05	5RBA8-PNM	9078A33G22	CLE-NLC-C	9078A67G17	5BCLS-600E	9570D64G04
15RBA8-NL	9078A30A05	5RBA8-PNM	9078A33G22	CLE-NLC-D	9078A67G20	5BCLS-750E	9570D64G05
15RBA8-NL	9078A30A05	8RBA8-GNM	9078A33G23	2CLE-PNM-C	9078A68G10	7BCLS-44R	9570D69G01
15RBA8-NL	9078A30A05	8RBA8-GNM	9078A33G23	5CLE-PNM-C	9078A68G11	7BCLS-44R	9570D69G01
15RBA8-NL	9078A30A05	8RBA8-GNM	9078A33G23	8CLE-PNM-C	9078A68G12	5CLE-1100E	9570D70G01
38RBA8-NL	9078A30A06	14RBA8-GNM	9078A33G24	15CLE-PNM-C	9078A68G13	5CLE-1350E	9570D70G02
38RBA8-NL	9078A30A06	14RBA8-GNM	9078A33G24	15CLE-HPNM-C	9078A68G14		
38RBA8-NL	9078A30A06	14RBA8-GNM	9078A33G24	2CLE-PNM-D	9078A68G15		
8RBA2-PNM	9078A33G02	15RBA2-PNM	9078A33G25	5CLE-PNM-D	9078A68G16		
8RBA2-PNM	9078A33G02	15RBA2-PNM	9078A33G25	8CLE-PNM-D	9078A68G17		
8RBA4-PNM	9078A33G02	15RBA4-PNM	9078A33G26	15CLE-PNM-D	9078A68G18		
8RBA4-PNM	9078A33G02	15RBA4-PNM	9078A33G26	15CLE-HPNM-D	9078A68G19		
14RBA2-PNM	9078A33G03	15RBA8-PNM	9078A33G27	2CLE-PNM-E	9078A68G20		
14RBA2-PNM	9078A33G03	15RBA8-PNM	9078A33G27	5CLE-PNM-E	9078A68G21		
25RBA2-PNM	9078A33G04	15RBA8-PNM	9078A33G27	8CLE-PNM-E	9078A68G22		
25RBA2-PNM	9078A33G04	25RBA8-PNM	9078A33G27	15CLE-PNM-E	9078A68G23		
38RBA2-PNM	9078A33G05	25RBA8-PNM	9078A33G27	2CLE-GNM-C	9078A68G31		
38RBA2-PNM	9078A33G05	25RBA8-PNM	9078A33G27	5CLE-GNM-C	9078A68G32		
5RBA2-PNM	9078A33G06	CLE-DF-C	9078A63G02	8CLE-GNM-C	9078A68G33		
5RBA2-PNM	9078A33G06	CLE-DF-D	9078A63G03	15CLE-GNM-C	9078A68G34		
5RBA4-PNM	9078A33G06	CLE-DF-E	9078A63G04	2CLE-GNM-D	9078A68G35		
5RBA4-PNM	9078A33G06	CLE-DL-C	9078A63G04	5CLE-GNM-D	9078A68G36		
14RBA4-PNM	9078A33G08	CLE-DL-E	9078A64G04	8CLE-GNM-D	9078A68G37		
14RBA4-PNM	9078A33G08	2CLE-PDM-C	9078A65G10	15CLE-GNM-D	9078A68G38		
25RBA4-PNM	9078A33G09	5CLE-PDM-C	9078A65G11	2CLE-GNM-E	9078A68G39		
25RBA4-PNM	9078A33G09	8CLE-PDM-C	9078A65G12	5CLE-GNM-E	9078A68G40		
38RBA4-PNM	9078A33G10	15CLE-PDM-C	9078A65G13	8CLE-GNM-E	9078A68G41		
38RBA4-PNM	9078A33G10	15CLE-HPDM-C	9078A65G14	8CXN-60C	9570D01G01		
8RBA8-PNM	9078A33G12	2CLE-PDM-D	9078A65G15	8CXN-100C	9570D01G02		
8RBA8-PNM	9078A33G12	5CLE-PDM-D	9078A65G16	8CXN-125C	9570D01G03		
8RBA8-PNM	9078A33G12	8CLE-PDM-D	9078A65G17	8CXN-150C	9570D01G04		
14RBA8-PNM	9078A33G13	15CLE-PDM-D	9078A65G18	8CXN-200C	9570D01G05		
14RBA8-PNM	9078A33G13	15CLE-HPDM-D	9078A65G19	8CXN-250C	9570D01G06		
14RBA8-PNM	9078A33G13	2CLE-PDM-E	9078A65G20	15CXN-45C	9570D02G02		
38RBA8-PNM	9078A33G15	5CLE-PDM-E	9078A65G21	15CXN-60C	9570D02G03		
38RBA8-PNM	9078A33G15	8CLE-PDM-E	9078A65G22	15CXN-75C	9570D02G04		
38RBA8-PNM	9078A33G15	15CLE-PDM-E	9078A65G23	15CXN-85C	9570D02G05		
5RBA2-GNM	9078A33G16	2CLE-GDM-C	9078A65G30	15CXN-100C	9570D02G06		