

Precision Indexing

CAMCO®

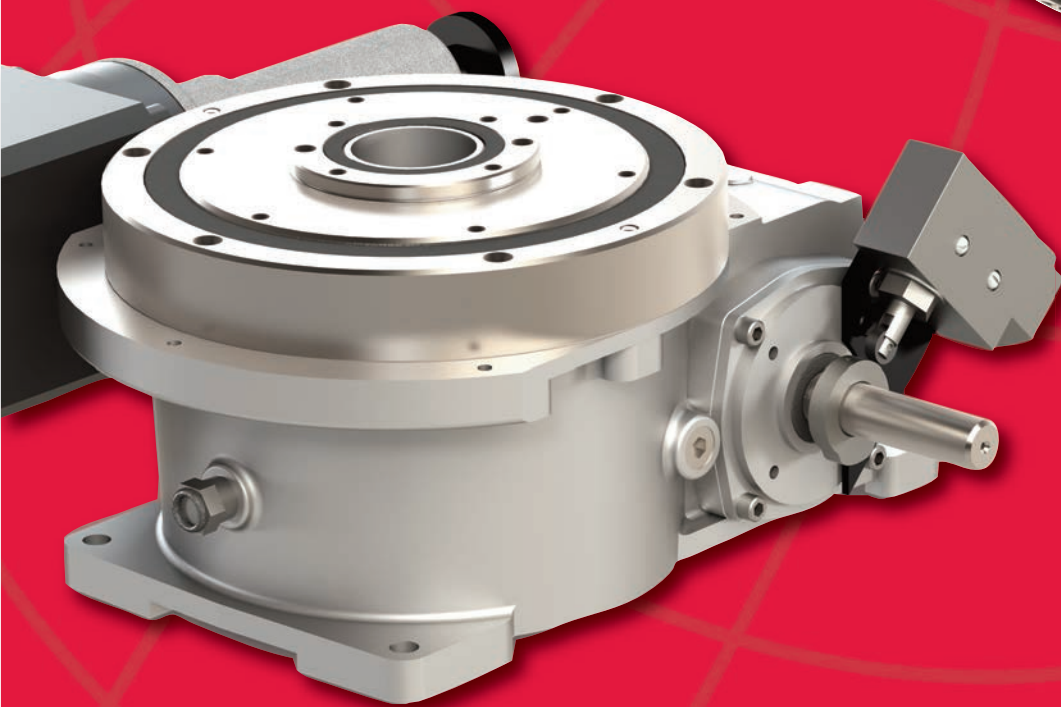

Indexers
Actuators
Conveyors

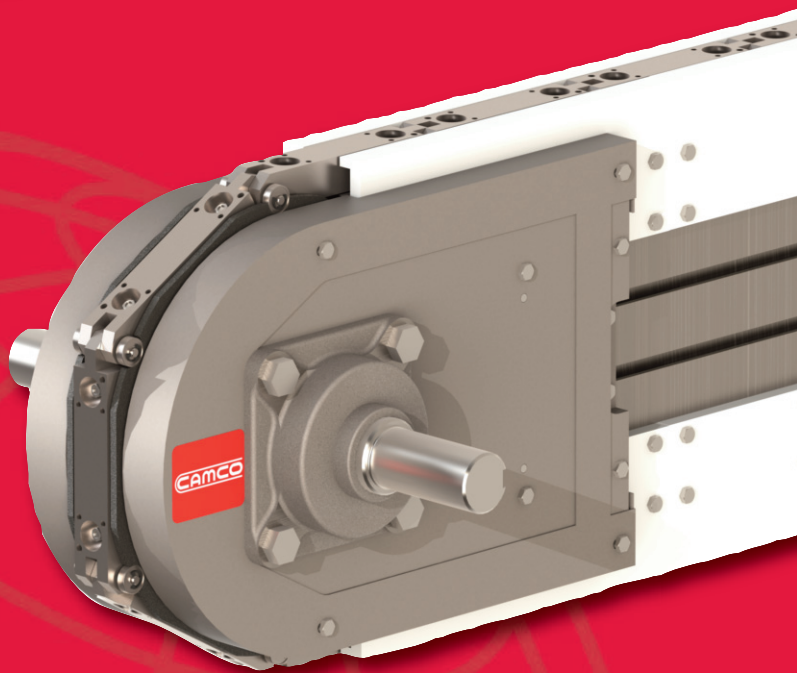



THE BEST PRODUCTS. UNMATCHED SERVICE. WORLDWIDE.

With a support network spanning the globe, DE-STA-CO offers consistent, comprehensive service to any location in the world. Whether your operations are localized or span multiple continents, you will always have access to the highest levels of customer service and technical support.

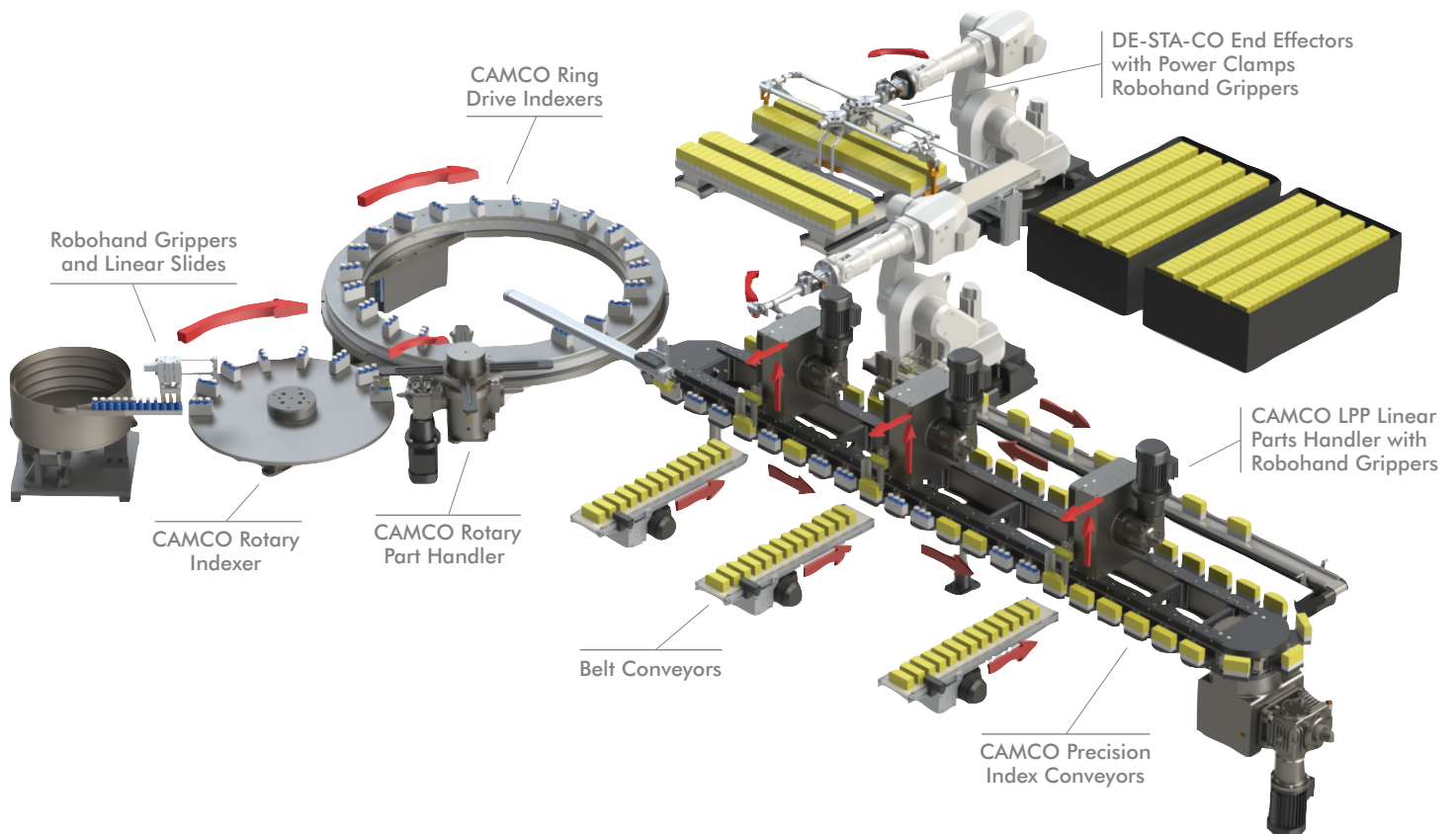

Dimensions and technical information are subject to change without notice.











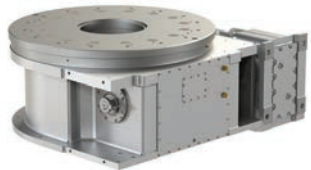
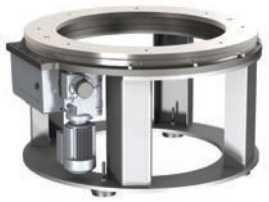

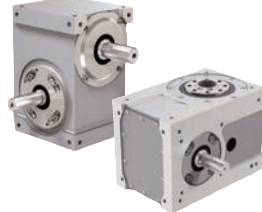
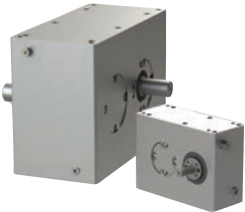
For more than 50 years, CAMCO global products have been the industry standard for the highest quality cam-actuated motion control products available. DE-STA-CO manufactures a wide range of motion control products including:

- Indexing Drives with right angle or parallel shaft orientation, and shaft or flange outputs, ranging from large index drives which can rotate several tons of automotive body parts in seconds to smaller index drives which can accurately index pharmaceutical or electronic components.
- Precision Link Conveyors provide precision positioning for linear transfer applications in table top and heavy-duty sizes. Combine with CAMCO Rotary or Linear Parts Handlers for a complete parts handling system.
- RSD Servo-Mechanical Drives provide zero-backlash speed reduction combined with a large flanged output and through hole for use with industry standard servo motors.

Product/Application Overview 4

Engineering Overview 9

			
RDM 39 Dial Indexer	RD 55 Heavy Duty Dial Indexer	E-Series 67 Heavy Duty Index Drive	RNG 79 Easy Access Indexer
			
RSD 88 Flexible Dial Indexer	DX 91 DX Servo Actuator	RGS/RGD 117 Shaft/Flange Indexer	Parallel 137 Shaft/Flange Indexer
			
RA 149 Right Angle Index Drive	Rite-Link 158 Conveyor	Table Top 161 Modular Conveyor	Heavy Duty 171 Modular Conveyor
			
LPP 181 Linear Parts Handlers	RPP 187 Rotary Parts Handlers	Overload Clutches .. 197 Output and Input	Custom Cams 208 Output and Input

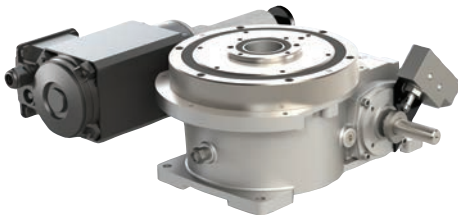

RDM Roller Dial Index Drives

The RDM Series Index Drive is ideal for rotary dial applications with features including:

- Low profile
- Large center thru hole
- Large output mounting surface supported by 4-point contact bearing, offering superior thrust and moment capacity
- Complete motorized drive packages and option overload clutch

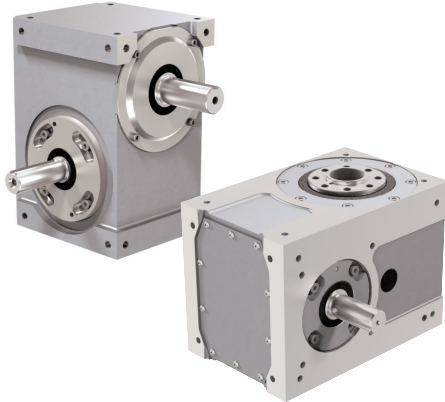

RGD/RGS Roller Gear Index Drives

Roller Gear Index Drives are robust, versatile units suitable for a wide variety of applications. Roller Gear Index Drives feature:

- Universal mounting with mounting holes on all six sides
- Flange or shaft output
- Center thru hole (flange version)
- Custom motions such as oscillating motions, or short index periods, available



RD Roller Dial Index Drives

Roller Dial Index Drives offer superior load capabilities, making them ideal for medium to high torque applications.

Other features include:

- Universal mounting, including horizontal mounting, ideal for trunion applications
- Center thru hole facilitates passage of electrical wiring, pneumatic lines or mechanical linkages
- Short camshaft motion periods are well-suited to continuous running applications or for special motion requirements
- Available with custom motions such as oscillating motions

Rite-Link Conveyor

The CAMCO Rite-Link Conveyor is a thin profile, preassembled, precision link system that offers maintenance free accuracy and durability for industrial conveying applications.

Other features include:

- Fully designed, assembled and tested for your application
- Slim, compact design with narrow link accommodates oversized tooling
- More accurate and stable than roller chain with high operating speed capabilities
- Servo-friendly for flexible indexing with CAMCO RSD rotary servo drive





DX Rotary Servo Actuator

The DX Series Drive is a programmable direct drive servo actuator with Safe Torque Off (STO) designed for small flexible dial applications.



RSD Rotary Servo Drive

SMARTER INDEXING: The CAMCO RSD Rotary Servo Drive is a zero-backlash, cam-actuated drive compatible with industry-standard servo motors for precise control, efficiency and flexibility.

- Designed to accept a variety of servo motors
- Preloaded for zero backlash, high accuracy, and smooth motion
- Indexing flexibility
- 4:1 to 18:1 ratio in single state

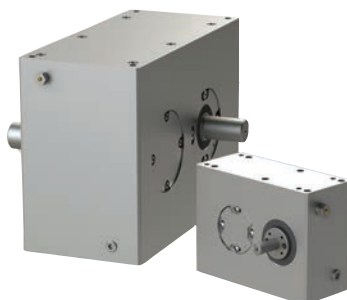

Parallel Index Drives

Parallel Index Drives are ideal for high-speed applications or for actuation-type applications such as driving a linkage or a conveyor.

- High-speed and high-load capability
- Whole or fractional stops, oscillating and complex custom motions are available
- Long transfer distances achieved with simple linkages
- Rigid and backlash free operation



Precision Link Conveyor Modular Table Top

Precision link conveyors provide designers and engineers with a multiple-station chassis for the assembly of more complicated products. Lengths from 3 feet to 40 feet, with link pitch of 3, 4.5 or 6 inches, are available to suit any requirement.

- Modular frame design in 18" increments for quick assembly and delivery
- Precision positioning of parts
- Open frame design for pass through of belting, linkages, and electric and air supply components
- Metric links also available, upon request

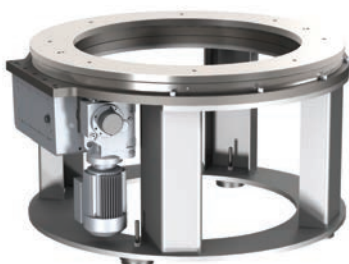

RNG Ring Index Drives

Ring Index Drives have a large center opening ideal for mounting auxiliary equipment within the center space, freeing floor space and providing operator access. The Ring Drive is ideally suited for pad printing and decorating equipment and for automatic assembly machinery applications that require a large number of workstations.

- Up to 60 station capability, ideal for multiple part automatic assembly machines
- Sealed 4-point contact output bearing for superior accuracy and load capability
- Modular shaft-mounted reducers for application flexibility and easy maintenance

Fixed and Flexible Dials, Conveyors and Parts Handlers

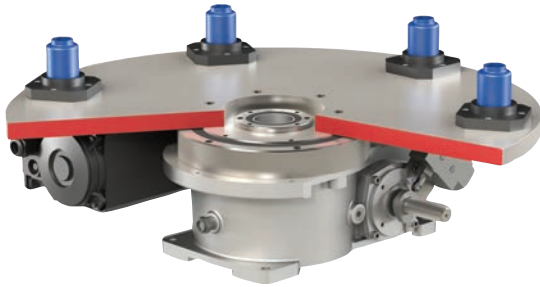

RDM Indexer with dial and fixed number of stations

- Operation is asynchronous (cycle on demand) – a single index followed by a variable dwell time.
- Index motion time is changed by adjusting the frequency setting of the inverter drive.
- Dwell time is variable.
- 30 cycles per minute with a DC motor and drive and 60 cycles per minute with an AC motor and drive.



115RSD Flexible Indexer with a dial

- Servo Driven Indexer with dial and variable number of stations
- Operation is asynchronous (cycle on demand) – a single index followed by a variable dwell time.
- Index motion time is changed by changing the motion profile of the servo motor.
- Dwell time is variable. Single axis servo or multiple axis servo controllers can be used.
- More than 60 cycles per minute – maximum cycle rate can be determined by your application engineer.

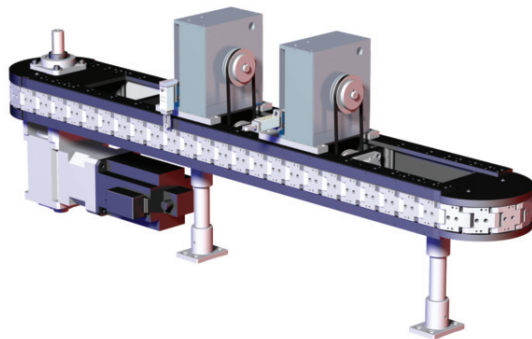

Indexer driving a conveyor and Linear Part Handlers

- Operation can be asynchronous (cycle on demand) – a single index followed by a variable dwell time, or the operation can be continuous.
- Index motion time is changed by changing the motion profile of the servo motor.
- Dwell time is variable. Single axis servo or multiple axis servo controllers can be used.
- More than 60 cycles per minute – maximum cycle rate can be determined by your application engineer.



CAMCO Cambot Parts Handlers with Robohand Electric Gripper

- CAMCO Cambot LPP Pick and Place mounted to conveyor chassis can be supplied with DE-STA-CO Robohand grippers and can be used to load and unload product. Rotary Pick and Place units are also available.
- All motion axes and grippers can be sequenced by your PLC.

Flexible Multi-Axis and High Speed



Flexible Cambot Pick and Place

The main rotary axis of the Flexible Cambot Pick and Place is a servo driven indexer. The indexer is used because it has a large output flange face with a large bearing. The linear axis is a Robohand slide. Spidergrip or BodyBuilder components can be connected to Robohand grippers or DE-STA-CO vacuum products to make complete custom end effector solutions.

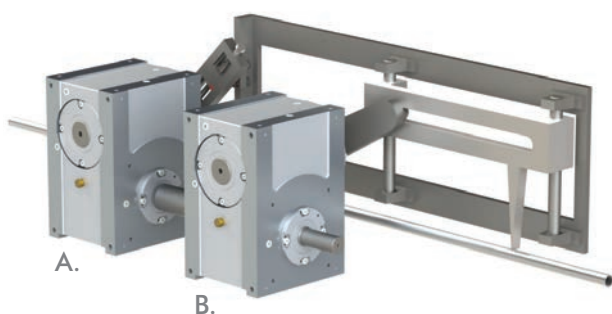

Flying Cutoff Application

This application takes a formed tube and cuts it to length. The inputs of two CAMCO roller gear models are coupled together and work together to produce the product. A slaved servo motor is used to drive the two CAMCO boxes and will stay in step with any possible speed variations of the tube line. The model on the left (A) is an indexer that has an adjustable length arm that moves a frame holding the cutting tool. The indexer moves the frame to match the speed and position. The model on the right (B) is an oscillator that moves the cutting tool down and up. The length of the tube is infinitely adjustable. Longer pieces are cut by increasing the arm length. Very long pieces are cut by allowing the tube to flow out before the servo motor is single cycled.

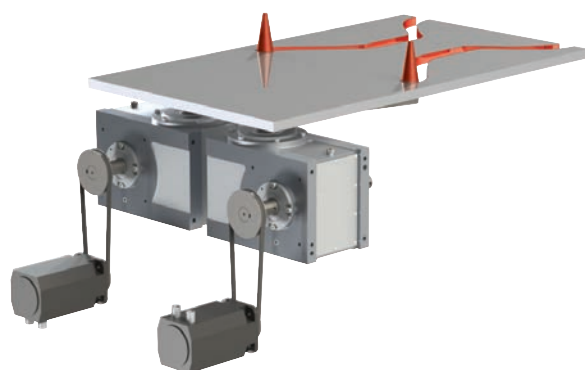

High Speed Contouring

This application requires high speed contouring (> 1000 ppm) of a paper or plastic web. Two CAMCO oscillators have lasers or similar cutting tools mounted to the ends of the oscillating arms attached to them. In this example, the customer submitted desired patterns for the finished product and CAMCO engineers designed cams that closely met the customer patterns, were dynamically stable and did not require maintenance. The two servos that drive the cam boxes are slaved to the web line and will stay in step with it.

Heavy-Duty Rotary

The E-Series Index Drive is ideal for heavy-duty rotary dial applications with features including:

- Large output mounting surface supported by a 4-point contact bearing superior thrust and moment capacity
- Large center thru hole to accommodate stationary center post, electrical wiring and air or hydraulic lines
- Complete motorized drive package with reducer and brake-motor combinations to suit most applications
- Precision cam with preloaded cam followers for maximum accuracy
- Durable welded steel housing
- Preloaded "center rib" design for smooth acceleration and deceleration with precision positioning

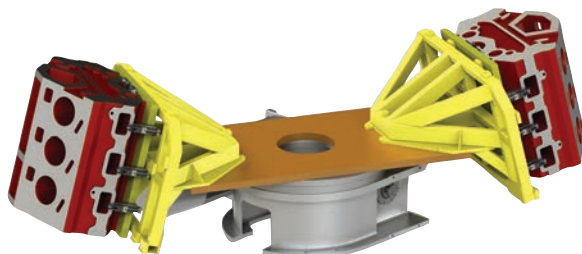

destaco.com



Scan with your mobile device to visit the new **destaco.com**



STAY | Informed

- Featured New Products
- Product Application Videos
- Press Releases - What's New
- Markets Served

STAY | Connected

- Global Contact and Support
- Find Regional Distributors
- Social Media Links

STAY | Productive

- Product Literature
- Pre-Configured CAD Downloads
- User-Defined CAD Downloads
- Request a Quote Online

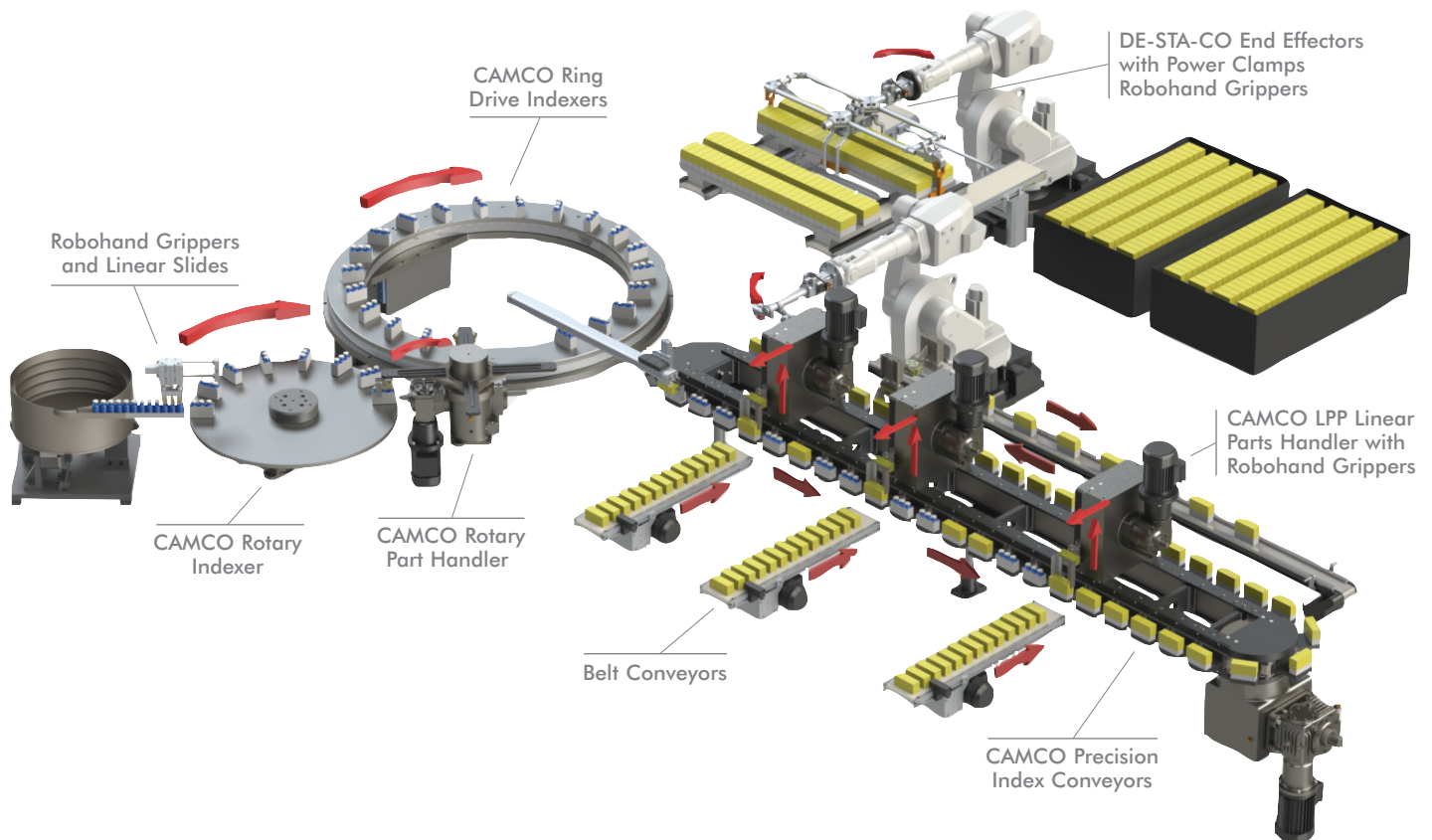

Why Cam-Actuated Index Drives?

The advantages of cam-controlled motion are obvious and effectively demonstrated in everyday life by the camshaft found in automobile engines. No other technology can provide comparable **speed, precision, repeatability, load capability and reliability**.

Cam-driven mechanisms require little or no maintenance and are capable of moving, with precision, a wide variety of products and components. For example – larger E-Series Index Drives rotate **several tons** of automotive body parts in seconds – and smaller P-Series and RG-Series index drives accurately index pharmaceutical components and electronic components in **milliseconds**. The mechanical technology typically requires no maintenance, other than routine checks for proper lubrication. Rolling pre-loaded contact between the cams and cam followers minimize wear and thermal inefficiencies. This preloading technique is also used on the input and output bearings of the index drive, achieving the most rigid, accurate and efficient mechanical actuator possible. With this inherent rigidity, settling time (the time to dampen any

vibrations) in dwell is short or virtually non-existent — very important for many applications requiring a combination of speed and precise positioning.

Through careful design of the cam profile, velocity and acceleration are also controlled throughout the indexing cycle, minimizing vibration and providing a known, repeatable displacement-time relationship.

In summary, cam-operated indexing systems have the following features and benefits:

- Controlled acceleration and decelerations
- Repeatable, accurate positioning
- High load capacity
- High speed capability
- Smooth motion
- Quick settling time in the dwell position
- Low maintenance, superior life
- Known displacement-time relationship
- Known power requirement

Dimensions and technical information are subject to change without notice.

Types of Motions

Controlled Indexing is comprised of three sections or phases: **acceleration, peak velocity and deceleration**. To optimize the transition from one phase to the next, several standard motion profiles have been developed. They include **Cycloidal, Modified Sine** and **Modified Trapezoidal**. In special circumstances, the motion required calls out for certain positions and/or velocities at certain times in the index cycle. Special **Polynomial** curves can be constructed for these applications. In other applications, the peak velocity needs to match the velocity of another component of the machine – and variations of

Polynomial and Modified Sine curves can be customized to suit the requirements.

DE-STA-CO/CAMCO usually employs Modified Sine curves due to their smooth transition from peak acceleration to deceleration and smooth power demand curves. Frequently, a period of peak, constant velocity is needed due to cam design or machine design requirements and a variation of this motion curve, **Modified Sine Constant Velocity** (abbreviated "msc"), is used.

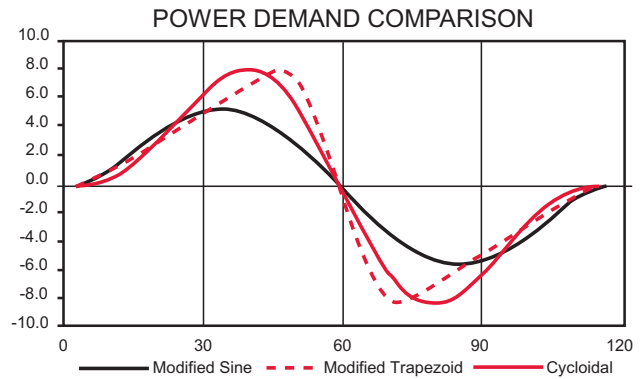
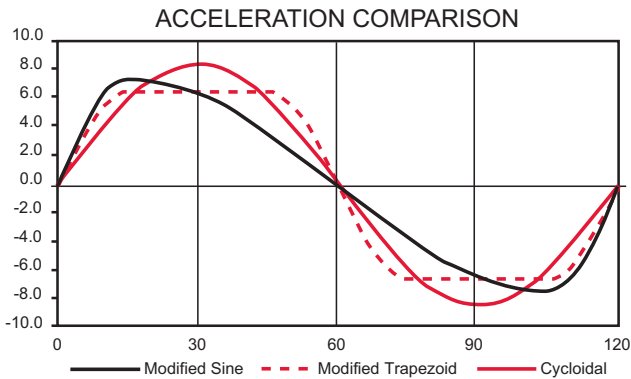

In addition to those motions already described, DE-STA-CO also has several other special application motions. They include **Modified Sine Quick Return (MSQR)** and **Synthesized Modified Sine Harmonic (SMSH)**. **MSQR** is an oscillating motion with no dwells. It has a forward stroke with a matched peak velocity and a quick return stroke. It is used in applications where a constant speed conveyor or rotating

dial is tracked (velocity is synchronized) in order to perform work during the synchronized movement. Examples are printing or moving a saw or cutting blade to cut parts to size. **SMSH** is a motion used in oscillating applications that require a dwell at one end of the stroke and no dwell at the other. This motion reduces the number of acceleration reversals.

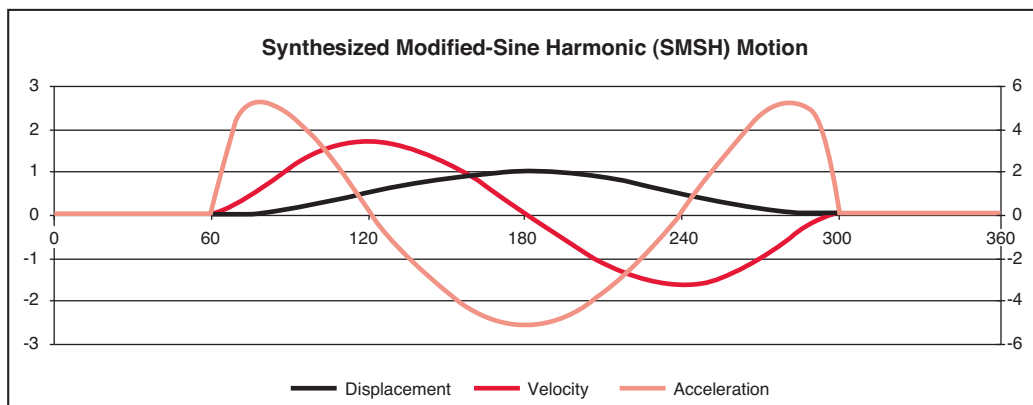

Dimensions and technical information are subject to change without notice.

Types of Index Drives

DE-STA-CO manufactures all three types of index drive geometries: **Roller Gear, Right Angle, and Parallel.**

Roller Gear



This family of indexers uses a globoidal (hourglass shaped) cam in conjunction with followers mounted radially outward from the circumference of the follower wheel, much like the teeth of a gear. The input shaft is perpendicular to the output shaft. With this right angle

configuration, it is possible to provide an optional large through-hole along the axis of the output shaft, or design a large output flange to accept dials (dial mounting). Large cam diameters relative to the output follower wheel allow for a wide range of special motions, short motion periods and a large output displacement for relatively smaller input displacement. In summary, **Roller Gear** Indexers provide:

- Compact low profile design
- Flanged output capability for dial mounting applications
- Through-hole capability (for electric and pneumatic lines or stationary center post)
- Motion flexibility (special and complex motions) due to relatively large cam
- 2 to 24 stop range

Right Angle

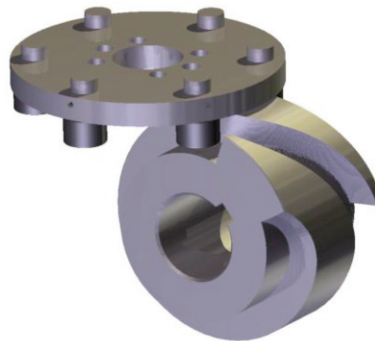

This family of indexers uses a cylindrical or barrel cam in conjunction with followers mounted parallel to the axis of the output. Similar to the Roller Gear, the input shaft is perpendicular to the output shaft. The cam is tucked partially underneath the output wheel, offering a more compact arrangement. For a given torque requirement, Right Angle indexers usually occupy the least amount of floor space and volume.

DE-STA-CO production equipment allows us to produce very large index drives in this geometry. Control of the cam rib thickness allows for preloading. Center distances between input shaft and output shaft can be fixed accurately. The minimum cam rib requirements limit the range of motions (output motions as a function of input motion) when compared to Roller Gear indexers. In summary, **Right Angle** Indexers provide:

- Most compact design for given output capacity
- Fixed center distance between output and input shafts (tighter tolerance on the distance between input and output shafts)
- Flanged output capability for dial mounting applications (e-series & rad series)
- Through-hole capability (e-series & rad series)
- 3 to 24 stop range
- Very large index drives for automotive assembly and large (up to 12 m/40 ft) dial diameters

Dimensions and technical information are subject to change without notice.

Types of Index Drives

(continued)

Parallel



This family of indexers use a pair of conjugate plate cams with yoke-mounted followers mounted parallel to the axis of the output. The input shaft is parallel to the output shaft. With this parallel configuration, there are no ribs on the cam as found on Roller Gear and Right Angle indexers. Also unique to the Parallel family is no reversal of the cam followers. Since they rotate in the same direction throughout the index cycle, index rates of over 1000 indexes per minute are possible. Without minimum rib requirements (no rib), larger followers can be used, providing high torque capability. Parallel indexers produce high output displacements for relatively smaller input displacements. The yoke-mounted geometry also makes the Parallel

family more resistant to shock loading (more robust). Double output shafts are also available. In summary, **Parallel** Indexers provide:

- High speed capability (with non-reversing followers)
- High load capability (with oversized followers)
- Shock resistance (more robust)
- Motion flexibility (special and complex motions) due to conjugate cam geometry
- 1 to 8 stop range

Operating a Cam Indexer

A cam indexer consists of an input and an output. The cam is mounted on the input and turns the output intermittently. The input will turn at a constant speed and during one portion of this turn the output will move (index) and during the remaining portion the output does not move (dwell). The number of index degrees during which the camshaft moves the output can be as little as 90 degrees and as great as 330 degrees. The number of dwell degrees respectively can be as much as 270 or as little as 30 degrees.

There are basically two ways to operate a cam indexer -Continuous (cont.) or Cycle On Demand (COD).

Continuous or Synchronous

Continuous applications are typically high speed, greater than 150 rpm. These applications are used in mass production of fast moving consumer goods such as paper cups, towels razor blades etc. The camshaft will turn at a continuous speed and the fixed amount of motion and dwell degrees determine the motion and dwell time in seconds. This time can be calculated by the formula $t = B / 6 / N$. Where B is the number of either motion or dwell degrees (360 -B) and N is the camshaft rpm.

If t_1 is the dwell time and t_2 is the index time, total cycle time $t_1 = t_1 + t_2$

Typically, the motion period of the cam is rarely less than 90 degrees, due to the geometry constraints of cam design. To illustrate, let's choose a 90 degree index (β_2), leaving 270 degrees (β_1) for dwell time ($90^\circ + 270^\circ = 360^\circ$ total)

Assume 60 RM camshaft or $N = 60$.

Then

$$\beta_{total} = 360^\circ = 6 \times N \times t_{total} \text{ or}$$

$$t_{total} = \frac{360}{6N} = \frac{360}{6 \times 60} = 1 \text{ sec.}$$

Continuous Input
Fixed Dwell Time

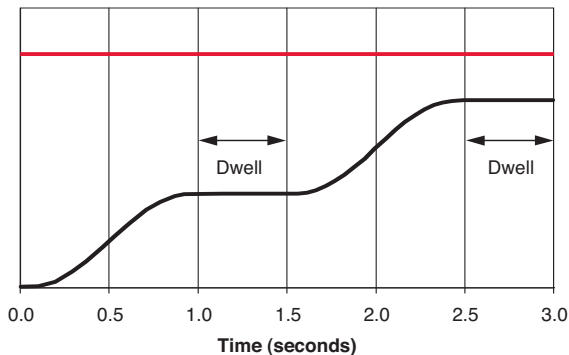

— Output Displacement — Camshaft Velocity

The index time

$$t_2 = \frac{\beta_1}{6N} = \frac{270}{6 \times 60} = 0.25 \text{ sec.}$$

And dwell time

$$t_1 = \frac{\beta_2}{6N} = \frac{90}{6 \times 60} = 0.75 \text{ sec.}$$

Note $t_1 = t_1 + t_2 = .75 + .25 = 1.0 \text{ sec.}$

In this example the ratio of dwell time to index time is .75 sec / .25 sec or 3:1.

Cycle On Demand

Suppose you need a longer dwell time to allow a robot or an operator to perform a function. You can stop the indexer in its dwell portion and allow it to be paused for as long as the operation requires. You will then restart the indexer to repeat the cycle. The indexer is stopped during its dwell portion so the accuracy is not compromised. In addition, during the dwell the mass attached to the output has already been stopped by the cam while it was running at full speed and so the load demand is greatly reduced as the camshaft, reducer and motor are the only masses being decelerated to a stop. Similarly the load demand of accelerating the motor and camshaft to speed is also reduced. A VFD cycling drive, brake motor or clutch brake can be used to start and stop the indexer in dwell. These drives can start and stop in a short amount of time or number of degrees. The 330 motion cam has a 30 degree dwell.

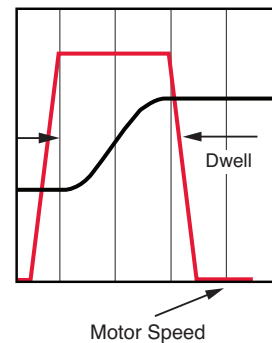

The remaining 15 degrees are used to stop the camshaft, reducer and motor

The index time is calculated

$$t_1 = \beta_2 / 6 / N = 330 / 6 / 150 = 0.366 \text{ seconds}$$

The dwell time is variable and depends upon the process.

Dimensions and technical information are subject to change without notice.

Approach to Sizing Index Drives - Metric

Within each family type (**Roller Gear, Right Angle, Parallel**), DE-STA-CO offers more than a dozen different sizes of CAMCO index drives. The first consideration when choosing an **index drive type** is mounting requirements and the geometry of the driven member. The mounting requirements usually determine the type of indexer and then size is selected. Often the geometry (size of dial, for example) helps determine the initial choice. The **index drive size** is verified through data sheet calculations.

All CAMCO indexers are designed and rated to have a **B₁₀** life of 8.000 hours on the followers and over 100.000 hours on the other major components. The **B₁₀** life is an estimate of time between cam follower replacement. For example, a **B₁₀** life estimate of 15.000 hours means that we can expect 10% of the followers to begin to show wear after 15.000 hours of operation. For this case, CAMCO would recommend replacing all of the followers after 15.000 hours of continuous operation.

Many helpful software programs have been developed by CAMCO to assist with the selection process. The following examples will show both a manual method of calculating and a faster method using special software.

Metric

All sizing for rotating equipment (motors, gear reducers and indexers) rely on the basic Newtonian Mechanics equation:

$$\text{Moment} = M_i = I\alpha$$

Where **I** is the Rotational Mass Moment of Inertia and α is the peak angular acceleration (radians/sec²).

Additional work or friction torque is also added, giving the full equation:

$$M_{\text{Total}} = I\alpha + M_w$$

Where $M_w = \text{Work Torque} = \mu \times R \times F$

μ = coefficient of friction, **R** = radius to Work Force and **F** = Force

For smaller diameter dial applications, Work Torque is negligible. For larger diameter dial applications, Work Torque can be significant. The inefficiencies of speed reducers also add to the total Work Torque.

After Torque is calculated we then determine the power requirements through:

$$\text{Power} = M \times \omega = I \times \alpha \times \omega$$

Where ω is the rotational velocity (radians/sec). Note that with an indexing application, α and ω are a function of time or $\alpha = f'(t)$ second derivative with respect to time and $\omega = f(t)$ first derivative with respect to time.

Since **I** is usually constant, power peaks when the product of α and ω peak. Software automatically chooses this peak product, and the manual data sheet methods rely on **K_i** and **K_f** factors to determine peak power. **K_i** and **K_f** are explained later in this Engineering catalog section.

Input (camshaft) torque requirements are calculated through the conservation of energy equation, Power in = Power out, or:

$$M_{in} \times \omega_{in} = M_{out} \times \omega_{out}$$

$$\text{Restated: } M_{in} = M_{\text{camshaft}} = M_c = M_{out} \times \omega_{out} / \omega_{in}$$

Note that:

$$K_i \equiv \omega_{out} / \omega_{in} \text{ at peak value of the product of } \alpha_{out} \times \omega_{out}$$

so we have:

$$M_{c(\text{inertia})} = M_{\text{inertia out}} \times K_i \text{ (for inertia)}$$

Similarly,

$$M_{c(\text{work})} = (M_{\text{work out}} + M_{\text{friction out}}) \times K_f \text{ (for friction and work torque)}$$

Where $K_f \equiv \omega_{out} / \omega_{in}$ at ω_{out} (maximum).

Total Camshaft Torque

$$M_c = M_{c(\text{inertia})} + M_{c(\text{work})}$$

Power demand is calculated based on Camshaft Torque and Speed

$$\text{Power} = \frac{M_c \times N}{9550 \times E} \text{ (kw)}$$

Where **N** = Camshaft speed in RPM

E = Efficiency of the gear reducer

M_c is in units of Nm.

Derivation of Torque Demand Equation for Indexing Dials - Metric

Inertia Torque, M_i , is defined by:

$$M_i = I \alpha$$

Where I = Rotational Mass Moment of Inertia (kgm²)

α = Peak angular acceleration (radians/sec²)

From the "Cam Design" manual by Mr. Clyde H. Moon:

$$\alpha = C_a \frac{\theta_o}{t_2^2}$$

Where C_a = Acceleration Coefficient (5,528 for modified sine motion)

θ_o = Output Angle or Angle of Index (radians)

t_2 = Index time (seconds)

The Output Angle, θ_o , is calculated based on the number of stops

$$\theta_o = \frac{2\pi}{S}$$

Where S = Number of stops

If the modified sine motion has constant velocity the acceleration factor, C_a , must be modified by a ratio of the C_a for the constant velocity relative to the C_a for a modified sine motion without constant velocity.

$$C = \frac{C_{a(cv)}}{C_a}$$

A service factor, SF, of 1,3 is added into the equation

Substituting, acceleration becomes

$$\alpha'' = \frac{C_a \times C \times SF \times 2\pi}{S \times t_2^2}$$

The final torque equation is then

$$M_i = \frac{I \times C_a \times C \times SF \times 2\pi}{S \times t_2^2}$$

Substituting the constants, with a 1,3 service factor

$$M_i = \frac{I \times 5,528 \times C \times 1,3 \times 2\pi}{S \times t_2^2}$$

$$M_i = \frac{45,15 \times I \times C}{S \times t_2^2} \text{ (Nm)}$$

We will use a dial and conveyor application to illustrate.

Approach to Sizing Index Drives - Imperial

Within each family type (**Roller Gear, Right Angle, Parallel**), DE-STA-CO offers more than a dozen different sizes of CAMCO index drives. The first consideration when choosing an **index drive type** is mounting requirements and the geometry of the driven member. The mounting requirements usually determine the type of indexer and then size is selected. Often the geometry (size of dial, for example) helps determine the initial choice. The **index drive size** is verified through data sheet calculations.

All CAMCO indexers are designed and rated to have a **B₁₀** life of 8.000 hours on the followers and over 100.000 hours on the other major components. The **B₁₀** life is an estimate of time between cam follower replacement. For example, a **B₁₀** life estimate of 15.000 hours means that we can expect 10% of the followers to begin to show wear after 15.000 hours of operation. For this case, CAMCO would recommend replacing all of the followers after 15.000 hours of continuous operation.

Many helpful software programs have been developed by CAMCO to assist with the selection process. The following examples will show both a manual method of calculating and a faster method using special software.

Imperial

All sizing for rotating equipment (motors, gear reducers and indexers) rely on the basic Newtonian Mechanics equation:

$$\text{Torque} = T_i = I \alpha$$

Where **I** is the Rotational Mass Moment of Inertia and α is the peak angular acceleration (radians/sec²).

Additional work or friction torque is also added, giving the full equation:

$$T_{\text{Total}} = I \alpha + T_w$$

Where $T_w = \text{Work Torque} = \mu \times R \times F$

μ = coefficient of friction, **R** = radius to Work Force and **F** = Force

For smaller diameter dial applications, Work Torque is negligible. For larger diameter dial applications, Work Torque can be significant. The inefficiencies of speed reducers also add to the total Work Torque.

After Torque is calculated we then determine the power requirements through:

$$\text{Power} = T \times \omega = I \times \alpha \times \omega$$

Where ω is the rotational velocity (radians/sec). Note that with an indexing application, α and ω are a function of time or $\alpha = f'(t)$ second derivative with respect to time and $\omega = f(t)$ first derivative with respect to time.

Since **I** is usually constant, power peaks when the product of α and ω peak. Software automatically chooses this peak product, and the manual data sheet methods rely on **K_i** and **K_f** factors to determine peak power. **K_i** and **K_f** are explained later in this Engineering catalog section.

Input (camshaft) torque requirements are calculated through the conservation of energy equation, Power in = Power out, or:

$$T_{\text{in}} \times \omega_{\text{in}} = T_{\text{out}} \times \omega_{\text{out}}$$

$$\text{Restated, } T_{\text{in}} = T_{\text{camshaft}} = T_c = T_{\text{out}} \times \omega_{\text{out}} / \omega_{\text{in}}$$

Note that:

$K_i \equiv \omega_{\text{out}} / \omega_{\text{in}}$ at peak value of the product of $\alpha_{\text{out}} \times \omega_{\text{out}}$ so we have:

$$T_{c(\text{inertia})} = T_{\text{inertia out}} \times K_i \text{ (for inertia)}$$

Similarly,

$$T_{c(\text{work})} = (T_{\text{work out}} + T_{\text{friction out}}) \times K_f \text{ (for friction and work torque)}$$

Where $K_f \equiv \omega_{\text{out}} / \omega_{\text{in}}$ at ω_{out} (maximum).

Total Camshaft Torque

$$T_c = T_{c(\text{inertia})} + T_{c(\text{work})}$$

Horsepower is calculated based on Camshaft Torque and Speed

$$\text{Power} = \text{HP} = \frac{T_c \times N}{63025 \times E} \text{ (Horsepower)}$$

Where **N** = Camshaft speed in RPM

E = Efficiency of the gear reducer

T_c is in units of in-lbs.

Derivation of Torque Demand Equation for Indexing Dials - Imperial

Inertia Torque, T_i , is defined by:

$$T_i = I \alpha$$

Where I = Rotational Mass Moment of Inertia
(in-lb-sec²)

α = Peak angular acceleration (radians/sec²)

From the "Cam Design" manual by Mr. Clyde H. Moon:

$$\alpha = C_a \frac{\theta_o}{t_2^2}$$

Where C_a = Acceleration Coefficient
(5.528 for modified sine motion)

θ_o = Output Angle or Angle of Index
(radians)

t_2 = Index time (seconds)

The Output Angle, θ , is calculated based on the number of stops

$$\theta_o = \frac{2\pi}{S}$$

Where S = Number of stops

If the modified sine motion has constant velocity the acceleration factor, C_a , must be modified by a ratio of the C_a for the constant velocity relative to the C_a for a modified sine motion without constant velocity.

$$C = \frac{C_{a(cv)}}{C_a}$$

A service factor, SF, of 1.3 is added into the equation

Substituting, acceleration becomes

$$\alpha = \frac{C_a \times C \times SF \times 2\pi}{S \times t_2^2}$$

DE-STA-CO calculates weight moment of inertia and then converts to mass moment of inertia:

$$I = \frac{Wk^2}{g}$$

Where Wk^2 = Weight Moment of Inertia (lb-in²)

g = Acceleration due to gravity
(386.4 in./sec²)

The final torque equation is then

$$T_i = \frac{Wk^2}{g} \frac{C_a \times C \times SF \times 2\pi}{S \times t_2^2}$$

Substituting the constants

$$T_i = \frac{Wk^2 \times 5.528 \times C \times SF \times 2\pi}{386.4 \times S \times t_2^2}$$

$$T_i = \frac{.09 \times SF \times Wk^2 \times C}{S \times t_2^2}$$

With a 1.3 service factor, the Inertia Torque Demand Equation is:

$$T_i = \frac{.117 \times Wk^2 \times C}{S \times t_2^2} \text{ (in.-lbs.)}$$

We will use a dial and conveyor application to illustrate.

Dial Application Example - Metric

Number of Stations	(S)	6
Weight of Single Station	(Ws)	10 kg
Radius to Station Center	(Rs)	250 mm
Dial Plate Diameter	(Dd)	600 mm
Dial Plate Mass	(Wd)	33,3 kg
Cycle Time	(t1)	2,0 sec.
Index Time	(t2)	0,75 sec.

Since dwell time is more than 3 times greater than the index time, the application will be cycle-on-demand.

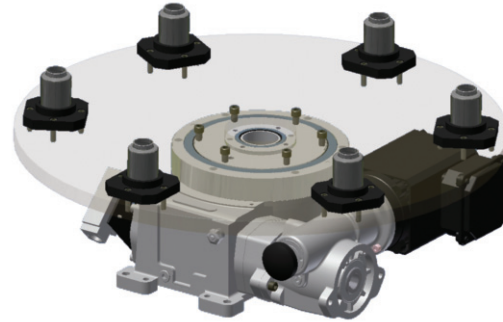

Dial Example

Index Period

$$\beta = 330^\circ$$

Since this is cycle-on-demand, choose a long, standard motion period.

Index Rate

$$N = \frac{\beta}{6 \times t_2} = \frac{330}{6 \times 0,75} = 73,33 \text{ index/min.}$$

Inertia Loading

Dial Plate Inertia

$$W_d \times \frac{D_d^2}{8} = 15 \times \frac{33,3 \times 0,600^2}{8} = 1,5 \text{ kgm}^2$$

Station Inertia

$$W_s \times S \times R_s^2 = 10 \times 6 \times 0,250^2 = 3,75 \text{ kgm}^2$$

Total External Inertia

$$(I_{(ext)}) = 1,5 + 3,75 = 5,25 \text{ kgm}^2$$

Preliminary Output Torque

$$M_i = \frac{34,7 \times SF \times I_{(ext)}}{S \times t_2^2} = \frac{34,7 \times 1,3 \times 5,75}{6 \times 0,5625} = 70,2 \text{ Nm}$$

The model M601RDM6H24-330 with an M4.0D overload clutch is the preliminary selection. B₁₀ capacity is 444 Nm @ 50 index/min. Indexer internal inertia is 0,033 kgm² and the overload clutch inertia is 0,02 kgm².

Adjust B₁₀ at 50 to B₁₀ at 73,33 to obtain the capacity at the required operating speed of 73,33 index/min.

$$\begin{aligned} B_{10} @ 73,33 &= B_{10} \text{ at } 50 \times (50/73,33)^{0,3} \\ &= 444 \times (50/73,33)^{0,3} \\ &= 395 \text{ Nm} \end{aligned}$$

Inertia Torque Calculation

The following formula includes a safety factor of 1,3.

$$\begin{aligned} M_i &= \frac{45,1 \times (I_{(ext)} + I_{(int)})}{S \times t_2^2} \\ &= \frac{45,1 \times (5,75 + 0,033 + 0,02)}{6 \times 0,5625} \\ &= 71 \text{ Nm} \end{aligned}$$

Camshaft Torque

$$K_f = \frac{C_v \times 360 \times M}{\beta \times S} = \frac{1,7596 \times 360 \times 1}{330 \times 6} = 0,32$$

$$K_i = 0,56 \times K_f = 0,56 \times 0,32 = 0,18$$

$$M_c = M_i \times K_i = 71 \times 0,18 = 12,7 \text{ Nm}$$

Note: C_v = Velocity coefficient for modified sine motion.

Camshaft RPM

$$N_c = \frac{\beta}{6 \times t_2 \times M} = \frac{330}{6 \times 0,75 \times 1} = 73,33 \text{ RPM}$$

Where M=1 for Type 1 indexers (see p. 26)

Reducer Selection

$$\frac{1400}{73,33} = 19$$

Assuming a 1400 RPM motor speed, the model R180 reducer with a 20:1 reduction ratio is selected.

Motor Power Demand

$$\text{Power} = \frac{M_c \times N_c}{9550 \times E} = \frac{12,7 \times 73,3}{9550 \times 0,75} = 0,13 \text{ kW}$$

Due to component compatibility and power requirements, a 0,25 kW motor is selected for this application.

Dimensions and technical information are subject to change without notice.



A DOVER COMPANY



Dial Application Datasheet

Customer..... -
 Address..... -
 City/State/Zip. -
 Engineer..... -
 Calculated By. -
 Cust. Email.... -
 Ph#... -
 Fax#... -
 P.O.#... -
 Date... -
 DS # -

APPLICATION DATA

Diameter Of Dial Plate.(Dd)=	600	mm
Thickness of Dial Plate...(Y)=	15	mm
Dial Plate Material.....	Steel	
Density of Dial Plate.....=	0.008	g/mm ³
Weight of Dial Plate...(Wd)=	33.3	Kg
Number of Stations.....(S)=	6	
Weight at Each Station.(Ws)=	10.0	Kg
Radius to Station Center(Rs)=	250	mm
Accuracy at Station Center=±	0.1077	mm
Additional Weight.		Kg

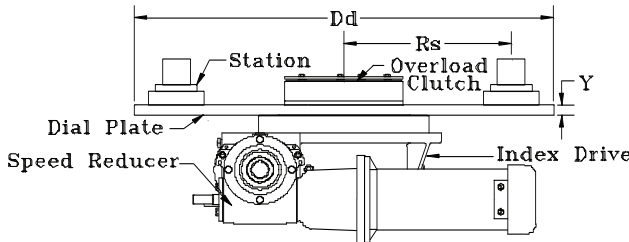

INDEX DATA

Index Time.....(t2)=	0.750	sec.
Dwell Time.....(t1)=	0.000	
Extended Dwell...=	9.11	sec.
Index Rate..... N =	73.33	ind./min.
COD Machine Cycle T:	10.00	sec.
Cycle T=	0.00	sec.

Index Period, B=(360)[t2/(t1+t2)]...B= **330**
 Percent Index Time =(B/360) x100 = **92%**
 Percent Constant Velocity.....F= **0.00**
 CV Adjustment Factor C = 1/(1-.24F-.76x(F²))
 Cam Type = **1**
 Kf.....= **0.32**
 Ki.....= **0.18**
 C.....= **1.00**

MOMENT OF INERTIA CALCULATIONS

Dial Plate = (Wd x Dd ²)/8 ...=	1.500	Kg-m ²
Stations = S x Ws x Rs ²=	3.750	Kg-m ²
Additional Inertia.....=	0.000	Kg-m ²
Overload Clutch Inertia.....=	0.020	Kg-m ²
Indexer Internal Inertia.....=	0.033	Kg-m ²
Total Wk²	5.303	Kg-m²

TORQUE CALCULATIONS

Inertia Torque, Ti = [0.117 x Wk ² x C] / [S x (t2) ²]	71	Nm
Friction Torque in the Indexer =	4	Nm
Friction Torque External to Indexer	0	Nm
Work Torque...Wt =	0	Nm
Total Output Torque=	75	Nm

Select Indexer Model

Follower wheel Pitch Diameter,PD=	157.1	mm
Indexer Camshaft Preload.....Tp=	3.4	Nm
Effective Radius of Gyration,..K= { Wk ² / [Wd + (S x Ws)] } ^{0.5}	238.36	mm
L10 Life of The Indexer	>100,000	Hours

INDEXER SF. 5.3		
B-10 Capacity at 50 ind./min.=	444	Nm
B-10 Capacity at 74 ind./min.=	396	Nm
K / (Pr)=	3.03	
Indexer Max. load=	525	Nm

Output Clutch

Output Clutch	4.0D	Minimum Torque Setting	130	Nm	Select Torque Setting	130	Nm
Camshaft Torque=	17 Nm	Motor Rated Speed	1640 rpm	Optimal Gear Ratio	22.36/1		
Camshaft RPM...=	73.33 RPM	Motor Speed with Selected Ratio	1466 rpm				

Reducer Model	CAMCO R180	Ratio	20	Side	1	Worm	LD	Mounting	C	Motor Adapter	IEC-71	Reducer Service Factor	3.2
Motor Reducer	none	1 / 1 Ratio			NONE			IEC-71		55 N-m@ 1750 RPM		Eff.	85%
											Input Reducer SF		

Application Calculated kw **0.18 Kw** (ADJUSTED FOR SPEED)

Select Motor Type	AC Variable Speed C-Face
0.33 HP, Kebco 230/460V/60Hz 3 Ø, 1640 RPM. IEC-71	

Index time at rated motor speed. **0.671** Seconds

Package Description:

CAMCO M601RDM6H24-330 6 Stop indexer with:
 CAMCO R180 Reducer with 20/1 reduction,
 IEC-71 Face adapter and coupling,
 Reducer mounting C, SIDE 1, LD worm

0.33 HP, Kebco 230/460V/60Hz 3 Ø, 1640 RPM. IEC-71 Motor
 4.0D Output overload clutch with 129 Nm torque setting

#NA

Representative:	DE-STA-CO
Address:	1444 South Wolf Road
Address:	
City:	Wheeling
State/Province:	Illinois
Zip Code:	60090
Country:	USA
Contact:	CAMCO
Title:	
Phone:	
Fax:	
email:	

All applications should be verified by Gold sizing software before orders are entered.

Dial Application Example - Imperial

Number of Stations	(S)	6
Weight of Single Station	(Ws)	5 lbs.
Radius to Station Center	(Rs)	10 in.
Dial Plate Diameter	(Dd)	24 in.
Dial Plate Mass	(Wd)	33.6 lbs.
Cycle Time	(t1)	2,0 sec.
Index Time	(t2)	0,75 sec.

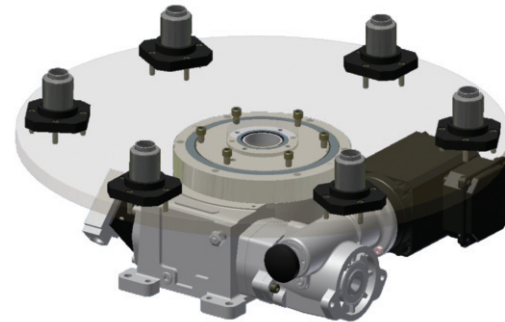

Since dwell time is more than 3 times greater than the index time, the application will be cycle-on-demand.

Dial Example

Index Period

$$\beta = 330^\circ$$

Since this is cycle-on-demand, choose a long, standard motion period.

Index Rate

$$N = \frac{\beta}{6 \times t_2} = \frac{330}{6 \times 0,75} = 73,33 \text{ index/min.}$$

Inertia Loading

Dial Plate Inertia

$$W_d \times \frac{D_d^2}{8} = 33.6 \times \frac{24^2}{8} = 2419 \text{ lb-in}^2$$

Station Inertia

$$W_s \times S \times R_s^2 = 5 \times 6 \times 10^2 = 3000 \text{ lb-in}^2$$

Total External Inertia

$$(Wk^2_{(ext)}) = 2419 + 3000 = 5419 \text{ lb-in}^2$$

Preliminary Output Torque

$$T_i = \frac{.09 \times SF \times Wk^2_{(ext.)}}{S \times t_2^2} = \frac{.09 \times 1.3 \times 5419}{6 \times .75^2} = 188 \text{ in-lbs}^2$$

The model 601RDM6H24-330 with an M4.0D overload clutch is the preliminary selection. B₁₀ capacity is 3928 in-lbs @ 50 index/min. Indexer internal inertia is 110 lb-in² and the overload clutch inertia is 69 lb-in².

Adjust B₁₀ at 50 to B₁₀ at 73,33 to obtain the capacity at the required operating speed of 73,33 index/min.

$$\begin{aligned} B_{10} @ 73.33 &= B_{10} \text{ at } 50 \times (50/73,33)^{0.3} \\ &= 3928 \times (50/73,33)^{0.3} \\ &= 3502 \text{ in-lbs} \end{aligned}$$

Inertia Torque Calculation

The following formula includes a safety factor of 1.3.

$$\begin{aligned} T_i &= \frac{0.09 \times SF \times (Wk^2_{(ext)} + Wk^2_{(int)})}{S \times t_2^2} \\ &= \frac{0.117 \times (5419 + 110)}{6 \times 0.75^2} \\ &= 192 \text{ in-lbs} \end{aligned}$$

Camshaft Torque

$$K_f = \frac{C_v \times 360 \times M}{\beta \times S} = \frac{1,7596 \times 360 \times 1}{330 \times 6} = 0.32$$

$$K_i = 0.56 \times K_f = 0.56 \times 0,32 = 0.18$$

$$M_c = M_i \times K_i = 192 \times 0.18 = 34.4 \text{ in-lb}$$

Note: C_v = Velocity coefficient for modified sine motion.

Camshaft RPM

$$N_c = \frac{\beta}{6 \times t_2 \times M} = \frac{330}{6 \times 0.75 \times 1} = 73.33 \text{ RPM}$$

Where M=1 for Type 1 indexers (see p. XX)

Reducer Selection

$$\frac{1400}{73,33} = 19$$

Assuming a 1400 RPM motor speed, the model R180 reducer with a 20:1 reduction ratio is selected.

Motor Power Demand

$$\text{Power} = \frac{M_c \times N_c}{63025 \times E} = \frac{34.4 \times 73.3}{63025 \times 0.75} = 0.06 \text{ Hp}$$

Due to component compatibility and power requirements, a 0.33 Hp motor is selected for this application.

Dimensions and technical information are subject to change without notice.



A DOVER COMPANY

Dial Application Datasheet

Customer..... - Ph#.... -
 Address..... - Fax#... -
 City/State/Zip. - P.O.#. -
 Engineer..... - Date... -
 Calculated By.- DS # -
 Cust. Email.... -

APPLICATION DATA

Diameter Of Dial Plate.(Dd)= **24** in.
 Thickness of Dial Plate...(Y)= **0.2615** in.
 Dial Plate Material..... **Steel**
 Density of Dial Plate.....= **0.284** lb./in³
 Weight of Dial Plate.....(Wd)= **33.6** lbs.
 Number of Stations.....(S)= **6**
 Weight at Each Station.(Ws)= **5.0** lbs.
 Radius to Station Center(Rs)= **10** in.
 Accuracy at Station Center=± **0.0043** in.
 Additional Weight. **0** lbs.

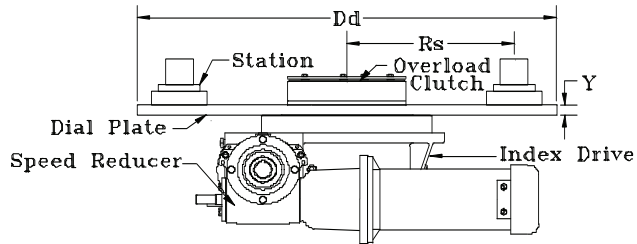

INDEX DATA

Cycle on Demand **0.750** sec.
 Index Time.....(t2)= **0.000** sec.
 Dwell Time.....(t1)= **9.11** sec.
 Extended Dwell...= **73.33** ind./min.
 Index Rate..... N = **10.00** sec. Cycle T= **0.00** sec.

Index Period, B=(360)[t2/(t1+t2)]...B = **330** Cam Type = **1**
 Percent Index Time =(B/360) x100 = **92%** Kf.....= **0.32**
 Percent Constant Velocity.....F = **0.00** Ki.....= **0.18**
 CV Adjustment Factor C = 1/(1-.24F-.76x(F²)) C.....= **1.00**

MOMENT OF INERTIA CALCULATIONS

Dial Plate = (Wd x Dd²)/8...= **2,418.993** lb.-in²
 Stations = S x Ws x Rs².....= **3,000.000** lb.-in²
 Additional Inertia.....= **0.000** lb.-in²
 Overload Clutch Inertia.....= **69.000** lb.-in²
 Indexer Internal Inertia.....= **112.000** lb.-in²
Total Wk².....= 5,599.993 lb.-in²

TORQUE CALCULATIONS

Inertia Torque, Ti =[.117 x Wk² x C] / [S x (t2)²] = **194** in.-lbs.
 Friction Torque in the Indexer = **10** in.-lbs.
 Friction Torque External to Indexer **0** in.-lbs.
 Work Torque...Wt = **0** in.-lbs.
Total Output Torque= 204 in.-lbs.

Select Indexer Model

601RDM6H24-330

INDEXER SF. **17.2**

Follower wheel Pitch Diameter,PD= **6.2** in. B-10 Capacity at 50 ind./min.= **3,928** in.-lbs.
 Indexer Camshaft Preload.....Tp= **30.0** in.-lbs. B-10 Capacity at 74 ind/min.= **3,502** in.-lbs.
 Effective Radius of Gyration, K= { Wk² / [Wd + (S x Ws)] }^{0.5}K= **9.38** in. K / (Pr)= **3.03**
L10 Life of The Indexer >100,000 Hours Indexer Max. load= **4649** in.-lbs.

Output Clutch

4.0D

Minimum Torque Setting **420** in.-lbs. Select Torque Setting **420** in.-lbs.

Camshaft Torque= 67 in.-lbs.	Motor Rated Speed 1640 rpm	Optimal Gear Ratio 22.36/1
Camshaft RPM...= 73.33 RPM	Motor Speed with Selected Ratio 1466 rpm	Reducer Service Factor 7.2
Reducer Model CAMCO R180	Ratio 20	Side 1
Worm LD	Mounting C	Motor Adapter IEC-71
Motor Reducer none	1 / 1 Ratio	Reducer Torque Rating 490 in.-lbs@ 1750 RPM
		Eff. 85%
		Input Reducer SF

Application Calculated Hp. **0.10** HP. (ADJUSTED FOR SPEED)

Select Motor Type **AC Variable Speed C-Face**
0.33 HP, Kebco 230/460V/60Hz 3 Ø, 1640 RPM. IEC-71

Index time at rated motor speed. **0.671** Seconds

Package Description:

CAMCO 601RDM6H24-330 6 Stop indexer with:
 CAMCO R180 Reducer with 20/1 reduction,
 IEC-71 Face adapter and coupling,
 Reducer mounting C, SIDE 1, LD worm

0.33 HP, Kebco 230/460V/60Hz 3 Ø, 1640 RPM. IEC-71 Motor
 4.0D Output overload clutch with 420 in-lb torque setting

#N/A

Representative:	DE-STA-CO
Address:	1444 South Wolf Road
Address:	none
City:	Wheeling
State/Province:	Illinois
Zip Code:	60090
Country:	USA
Contact:	CAMCO
Title:	
Phone:	
Fax:	
email:	

All applications should be verified by Gold sizing software before orders are entered.

Precision Link Conveyor Application Example - Metric

Over/Under Precision Link Conveyor

Index Distance	(S _x)	115 mm
Index Time	(t ₂)	0,5 sec.
Dwell Time	(t ₁)	0,5 sec.
Chain Pitch	(p)	115 mm
Sprocket Pitch Dia.	(D _s)	300,509 mm
Sprocket Weight	(W _{ds})	14,911 kg
Number of Teeth on Sprocket	(n)	8
Center Distance	(CD)	2300 mm
Number of Links	(NL)	= n + 2 x CD / p = 8 + 2 x 2300 / 115 = 8 + 2 x 20 NL = 48
Weight of Link		1,36 kg
Indexed Parts Weight	(W _p)	65,472 kg
Chain & Fixture Weight	(W _c)	NL x weight placed on link (W _c) 48 x 0,272 kg (W _c) 13,056
Coefficient of Friction	(μ)	0,15



Conveyors can be run either as cycle on demand or continuously. We will chose to run continuously because of the very short time for move and dwell.

Index Period

For this cycle-on-demand application, the index period should be 270° or larger.

$$B = 360 \times \frac{t_2}{(t_2 + t_1)} \text{ or}$$

$$B = 360 \times \frac{0,5}{(0,5 + 0,5)} = 180$$

Number of Stops

$$S = \frac{n \times p}{S_x} = \frac{8 \times 115}{115} = 8$$

Index Rate

For continuous running the index rate is calculated by

$$N = \frac{60}{(t_1 \times t_2)} \text{ or}$$

$$N = \frac{60}{(0,5 \times 0,5)} = 60 \text{ index/min.}$$

Inertia Calculations

Drive Sprocket

$$W_{ds} \times \frac{D_s^2}{8} = \frac{14,911 \times 0,300^2}{8} = 0,168 \text{ kgm}^2$$

Note: Most CAMCO Precision Link Conveyors use a chordal compensation cam at the take-up end. No take-up sprocket is necessary.

Inertia Calculations (continued)

Chains and Fixtures

$$W_c \times \frac{D_s^2}{4} = 13,056 \times \frac{0,300^2}{4} = 0,294 \text{ kgm}^2$$

Parts

$$W_{ds} \times \frac{D_s^2}{4} = 65,472 \times \frac{0,300^2}{4} = 1,473 \text{ kgm}^2$$

Total External Inertia

$$I_{(ext.)} = 0,168 + 0,294 + 1,473 = 1,935 \text{ kgm}^2$$

Preliminary Inertia Torque

$$M_i = \frac{34,7 \times SF \times Wk^2_{(ext)}}{S \times t_2^2} = \frac{34,7 \times 1,3 \times 1,935}{8 \times 0,5^2} = 43,64 \text{ Nm}$$

This formula M_i includes a service factor of 1,3.

Friction Torque

$$M_f = \frac{(W_c + W_p) \times D_s \times 9,81 \times \mu}{2} = \frac{(13,056 + 65,472) \times 0,300 \times 9,81 \times 0,15}{2} = 17,33 \text{ Nm}$$

Precision Link Conveyor Application Example - Metric

Work Torque

The parts are being translated horizontally; therefore there is no work torque.

Preliminary Output Torque Calculation

$$M_o = M_i + M_f + M_w = 43,64 + 17,33 + 0 = 60,97 \text{ Nm}$$

Using the appropriate catalog section, select an index drive corresponding to the preliminary torque requirements.

$$B_{10} = \frac{T_o}{\left(\frac{50}{N}\right)^{0.3}} = \frac{60,97}{\left(\frac{50}{60}\right)^{0.3}} = 64,4 \text{ Nm}$$

Select M401RA8H24-180, modified sine motion (ms), $Wk^2_{(int)} = 0,0044 \text{ kgm}^2$, B_{10} capacity = 248 Nm

Overload Protection

Output overload protection should be used with this application. A large instantaneous gear ratio at the start of index makes output overload protection the preferred method for protecting the index drive. With an output overload clutch, jams or overloads at the start of index can easily be detected prior to damaging the indexer.

From your CAMCO catalog, select the appropriate clutch model for the index drive being used. Clutch model M2.3FC-SD with $I_{(cl.)} = 0,0091 \text{ kgm}^2$ is chosen.

Inertia Torque

The actual inertia torque including indexer internal inertia and clutch inertia can now be calculated.

$$\begin{aligned} M_i &= \frac{45,1 \times (I_{(ext)} + I_{(int)} + I_{(cl)}) \times C}{S \times t_2^2} \\ &= \frac{45,1 \times (1,935 + 0,0044 + 0,0091) \times 1}{8 \times 0,5^2} \\ &= 43,94 \text{ Nm} \end{aligned}$$

Output Torque

$$M_o = M_i + M_f + M_w = 43,94 + 17,33 + 0 = 61,27 \text{ Nm}$$

C, K_i and K_f

Values for C, K_i and K_f can be calculated or found in the table on page XX (Moon factor tables).

$$C = 1,0, K_i = 0,25, K_f = 0,44$$

Camshaft Torque

$$\begin{aligned} M_c &= (M_i \times K_i) + (M_f \times K_f) + (M_w \times K_w) \\ &= (43,94 \times 0,25) + (17,33 \times 0,44) + 0 \\ &= 18,61 \text{ Nm} \end{aligned}$$

Camshaft RPM

$$N_c = \frac{\beta}{6 \times t_2 \times M} = \frac{180}{6 \times 0,5 \times 1} = 60 \text{ RPM}$$

This is a type 1 unit, therefore $M=1$.
For type 2 or 3, $M=2$, $M=3$.

Reducer Selection

Assuming an 1800RPM motor speed, the model R180 reducer with a 30:1 reduction ratio is selected.

Motor Power Demand

$$\text{Power} = \frac{M_c \times N_c}{9550 \times E} = \frac{18,61 \times 60}{9550 \times 0,75} = 0,16 \text{ kW}$$

Due to component compatibility and power requirements, a 0,75 kW motor is selected for this application.



Conveyor Application Datasheet

Customer..... -
 Address..... -
 City/State/Zip. -
 Engineer..... -
 Calculated By. -
 Cust. Email... -

Ph#... -
 Fax#... -
 P.O.#. -
 Date... -
 DS # -

APPLICATION DATA

Metric

X - Index Distance	115.000 mm	Sprocket Weight	14.911 Kg
CD - Center Distance	2300.000 mm	Link Weight	0.272 Kg
Weight per link	1.364 Kg	Number of Links	48
Gear Ratio	0.000	Maximum Torque	106.328 Nm
Sprocket Diameter	300.509 mm	Conveyor Inertia	1.921 Kg-m ²
Number of Stops	8.000	Friction Torque	17.316 Nm
Sprocket Inertia	0.153 Kg-m ²	Total Weight	93.413 Kg
Number of Sprocket Teeth	8		
Accuracy at Station Center=±	0.0711 mm		
Additional Weight.	93.413 Kg		

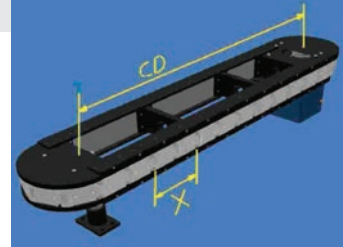

115 mm link Medical RiteLink Conveyor 2300 mm center distance

INDEX DATA

Continuous

Index Time.....(t2)=	0.500 sec.	Index Period, B=(360)[t2/(t1+t2)]...B=	180	Cam Type =	1
Dwell Time.....(t1)=	0.500	Percent Index Time =(B/360) x100 =	50%	Kf.....=	0.44
Extended Dwell...=	0.00 sec.	Percent Constant Velocity.....F=	0.00	Ki.....=	0.25
Index Rate..... N =	60.00 ind./min.	CV Adjustment Factor C = 1/(1-.24F-.76x(F ²))		C.....=	1.00
COD Machine Cycle	10.00 sec.	Cycle T=	1.00 sec.		

MOMENT OF INERTIA CALCULATIONS

Additional Inertia.....	1.921	Kg-m ²
Overload Clutch Inertia.....=	0.013	Kg-m ²
Indexer Internal Inertia.....=	0.004	Kg-m ²
Total Wk^2.....=	1.938	Kg-m²

Select Indexer Type **RA**
 Select Indexer Size **400RA**
 Select From All Codes Available

TORQUE CALCULATIONS

Inertia Torque, Ti =[.117 x Wk ² x C] / [S x (t2) ²] =	44	Nm
Friction Torque in the Indexer =	0	Nm
Friction Torque External to Indexer	17.316	Nm
Work Torque...Wt =	0	Nm
Total Output Torque=	61	Nm

Select Indexer Model

400RA8H24-180

INDEXER SF. 3.8

Follower wheel Pitch Diameter,PD=	101.6 mm	B-10 Capacity at 50 ind./min.=	248 Nm
Indexer Camshaft Preload.....Tp=	7.9 Nm	B-10 Capacity at 60 ind/min.=	235 Nm
Effective Radius of Gyration, K= { Wk ² / [Wd + (S x Ws)]} ^{0.5}K=	70.04 mm	K / (Pr)=	1.38
L10 Life of The Indexer	>100,000 Hours	Indexer Max. load=	226 Nm

Output Clutch

2.3FC-SD

Minimum Torque Setting	96 Nm	Select Torque Setting	96 Nm
------------------------	-------	-----------------------	-------

Camshaft Torque=	26 Nm	Motor Rated Speed	1640 rpm	Optimal Gear Ratio	27.33/1
Camshaft RPM...=	60 RPM	Motor Speed with Selected Ratio	1800 rpm		

Reducer Model	CAMCO R180	Ratio	30	Side	1	Worm	LD	Mounting	C	Motor Adapter	IEC-71	Reducer Service Factor	2.1	Reducer Torque Rating	55 N-m@ 1750 RPM	Eff.	85%
Motor Reducer	none	1 / 1 Ratio								NONE		Input Reducer SF					

Application Calculated kw 0.18 Kw

Select Motor Type AC Variable Speed C-Face

0.33 HP, Kebco 230/460V/60Hz 3 Ø, 1640 RPM. IEC-71

Index time at rated motor speed. 0.549 Seconds

Package Description:

CAMCO M400RA8H24-180 8 Stop indexer with:
 CAMCO R180 Reducer with 30/1 reduction,
 IEC-71 Face adapter and coupling,
 Reducer mounting C, SIDE 1, LD worm

0.33 HP, Kebco 230/460V/60Hz 3 Ø, 1640 RPM. IEC-71 Motor
 2.3FC-SD Output overload clutch with 96 in-lb torque setting

#N/A

Representative:	DE-STA-CO
Address:	1444 South Wolf Road
Address:	none
City:	Wheeling
State/Province:	Illinois
Zip Code:	60090
Country:	USA
Contact:	CAMCO
Title:	
Phone:	
Fax:	
email:	

All applications should be verified by Gold sizing software before orders are entered.

Dimensions and technical information are subject to change without notice.

Precision Link Conveyor Application Example - Imperial

Over/Under Precision Link Conveyor

Index Distance	(S_x)	4.5 in.
Index Time	(t_2)	0.5 sec.
Dwell Time	(t_1)	0.5 sec.
Chain Pitch	(p)	4.5 in.
Sprocket Pitch Dia.	(D_s)	11.758 in.
Sprocket Weight	(W_{ds})	16.498 lbs. kg
Number of Teeth on Sprocket	(n)	8
Center Distance	(CD)	180 in.
Number of Links	(NL)	$= n + 2 \times CD / p$ $= 8 + 2 \times 180 / 4.5$ $= 8 + 2 \times 40$ NL = 88
Weight of Link		3 lbs.
Indexed Parts Weight	(W_p)	264 lbs.
Chain & Fixture Weight	(W_c)	NL x weight placed on link (W_c) 88 x 2 (W_c) 176 lbs.
Coefficient of Friction	(μ)	0.15

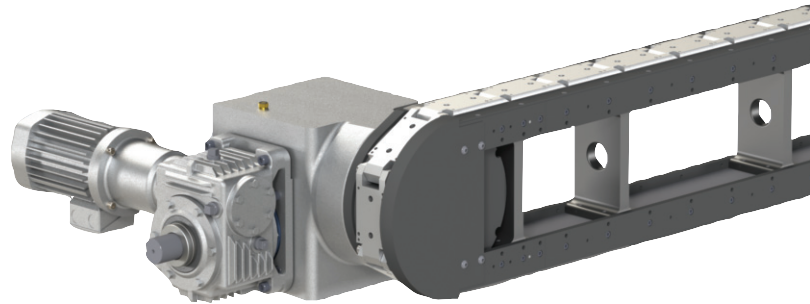

Conveyors can be run either as cycle on demand or continuously. We will chose to run continuously because of the very short time for move and dwell.

Index Period

For this cycle-on-demand application, the index period should be 270° or larger.

$$B = 360 \times \frac{t_2}{(t_2 + t_1)} \quad \text{or}$$

$$B = 360 \times \frac{0.5}{(0.5 + 0.5)} = 180$$

Number of Stops

$$S = \frac{n \times p}{S_x} = \frac{8 \times 4.5}{4.5} = 8$$

Index Rate

For continuous running the index rate is calculated by

$$N = \frac{60}{(t_1 \times t_2)} \quad \text{or}$$

$$N = \frac{60}{(0.5 \times .05)} = 60 \text{ index/min.}$$

Inertia Calculations

Drive Sprocket

$$W_{ds} \times \frac{D_s^2}{8} = 61.49 \times \frac{11.758^2}{8} = 1063 \text{ lb-in}^2$$

Note: Most CAMCO Precision Link Conveyors use a chordal compensation cam at the take-up end. No take-up sprocket is necessary.

Inertia Calculations (continued)

Chains and Fixtures

$$W_c \times \frac{D_s^2}{4} = 176 \times \frac{11.758^2}{4} = 6083 \text{ lb-in}^2$$

Parts

$$W_{ds} \times \frac{D_s^2}{4} = 264 \times \frac{11.758^2}{4} = 9125 \text{ lb-in}^2$$

Total External Inertia

$$Wk^2_{(ext.)} = 1063 + 6083 + 9125 = 16271 \text{ lb-in}^2$$

Preliminary Inertia Torque

$$T_i = \frac{.09 \times SF \times Wk^2_{(ext.)}}{S \times t_2^2} = \frac{.09 \times 1.3 \times 16271}{8 \times 0.5^2} = 952 \text{ in-lb}$$

This formula M_i includes a service factor of 1,3.

Friction Torque

$$T_f = \frac{(W_c + W_p) \times D_s \times \mu}{2} = \frac{(176 + 264) \times 11.758 \times 0.15}{2} = 226 \text{ in-lbs}$$

Precision Link Conveyor Application Example - Imperial

Work Torque

The parts are being translated horizontally; therefore there is no work torque.

Preliminary Output Torque Calculation

$$T_o = T_i + T_f + T_w = 952 + 388 + 0 = 1340 \text{ in-lbs}$$

Using the appropriate catalog section, select an index drive corresponding to the preliminary torque requirements.

$$B_{10} = \frac{T_o}{\left(\frac{50}{N}\right)^{0.3}} = \frac{1340}{\left(\frac{50}{60}\right)^{0.3}} = 1415 \text{ in-lbs}$$

Select 500RGS8H40-180, modified sine motion (ms), $Wk^2_{(int)} = 48.72 \text{ lbs-in}^2$, B_{10} capacity = 7006 in-lbs

Overload Protection

Output overload protection should be used with this application. A large instantaneous gear ratio at the start of index makes output overload protection the preferred method for protecting the index drive. With an output overload clutch, jams or overloads at the start of index can easily be detected prior to damaging the indexer.

From your CAMCO catalog, select the appropriate clutch model for the index drive being used. Clutch model 11FC-SD with $Wk^2_{(cl.)} = 340 \text{ lbs-in}^2$ is chosen.

Inertia Torque

The actual inertia torque including indexer internal inertia and clutch inertia can now be calculated.

$$\begin{aligned} T_i &= \frac{.09 \times SF \times (Wk^2_{(ext.)} + Wk^2_{(int.)} + Wk^2_{(cl.)}) \times C}{S \times t_2^2} \\ &= \frac{.09 \times 1.3 \times (16271 + 48.72 + 340) \times 1}{8 \times 0.5^2} \\ &= 975 \text{ in-lbs} \end{aligned}$$

Output Torque

$$T_o = T_i + T_f + T_w = 975 + 388 + 0 = 1363 \text{ in.-lbs.}$$

C, K_i and K_f

Values for C, K_i and K_f can be calculated or found in the table on page XX (Moon factor tables).

$$C = 1.0, K_i = 0.25, K_f = 0.44$$

Camshaft Torque

$$\begin{aligned} T_c &= (T_i \times T_i) + (T_f \times K_f) + (T_w \times K_w) \\ &= (975 \times 0.25) + (388 \times 0.44) + 0 \\ &= 415 \text{ in-lbs} \end{aligned}$$

Camshaft RPM

$$N_c = \frac{\beta}{6 \times t_2 \times M} = \frac{180}{6 \times 0.5 \times 1} = 60 \text{ RPM}$$

This is a type 1 unit, therefore $M=1$.
For type 2 or 3, $M=2$, $M=3$.

Reducer Selection

Assuming an 1800RPM motor speed, the model R180 reducer with a 30:1 reduction ratio is selected.

Horsepower

$$Hp = \frac{T_c \times N_c}{63,025 \times E} = \frac{415 \times 60}{63,025 \times 0.75} = 0.53 \text{ Hp}$$

Due to component compatibility and power requirements, a 1 Hp motor is selected for this application.



Conveyor Application Datasheet

Customer..... -
 Address..... -
 City/State/Zip. -
 Engineer..... -
 Calculated By.-
 Cust. Email.... -
 Ph#... -
 Fax#... -
 P.O.#. -
 Date... -
 DS # -

APPLICATION DATA **Imperial**

X - Index Distance	4.500 in	Sprocket Weight	61.490 lbs
CD - Center Distance	180.000 in	Link Weight	2.000 lbs
Weight per link	3.000 lbs	Number of Links	88
Gear Ratio	1.000	Maximum Torque	19,917.000 in-lbs
Sprocket Diameter	11.758 in	Conveyor Inertia	15,913.082 lb-in ²
Number of Stops	8.000	Friction Torque	388.014 in-lbs
Sprocket Inertia	705.520 lb-in ²	Total Weight	501.490 lbs
Number of Sprocket Teeth	8		
Accuracy at Station Center=±	0.0017 in.		
Additional Weight.	501.490 lbs.		

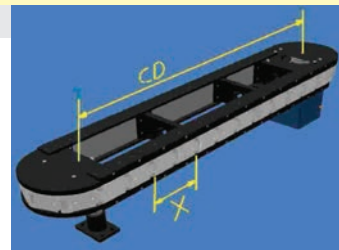

4.5 Inch Link Modular Table Top Conveyor w/ Aluminum Links 180 Inches center distance

INDEX DATA

Continuous
 Index Time.....(t2)= 0.500 sec.
 Dwell Time.....(t1)= 0.500 sec.
 Extended Dwell...= 0.00 sec.
 Index Rate..... N = 60.00 ind./min.
 COD Machine Cycle 10.00 sec. Cycle T= 1.00 sec.
 Index Period, B=(360)/[t2/(t1+t2)]...B= 180
 Percent Index Time =(B/360) x100 = 50%
 Percent Constant Velocity.....F= 0.00
 CV Adjustment Factor C = 1/(1-.24F-.76x(F²))
 Cam Type = 1
 Kf.....= 0.44
 Ki.....= 0.25
 C.....= 1.00

MOMENT OF INERTIA CALCULATIONS

TORQUE CALCULATIONS

Additional Inertia.....=	15,913.082	lb.-in ²	Inertia Torque, Ti =[.117 x Wk ² x C] / [S x (t2) ²] =	954	in.-lbs.
Overload Clutch Inertia.....=	340.000	lb.-in ²	Friction Torque in the Indexer =	0	in.-lbs.
Indexer Internal Inertia.....=	48.270	lb.-in ²	Friction Torque External to Indexer	388.014	in.-lbs.
Total Wk².....=	16,301.352	lb.-in²	Work Torque...Wt =	0	in.-lbs.
			Total Output Torque=	1,342	in.-lbs.

Select Indexer Model

500RGS8H40-180

INDEXER SF. 4.9

Follower wheel Pitch Diameter,PD=	5.0	in.	B-10 Capacity at 50 ind./min.=	7,006	in.-lbs.
Indexer Camshaft Preload.....Tp=	200.0	in.-lbs.	B-10 Capacity at 60 ind/min.=	6,633	in.-lbs.
Effective Radius of Gyration, K={ Wk ² / [Wd + (S x Ws)]} ^{0.5}K=	1.63	in.	K / (Pr)=	0.65	
L10 Life of The Indexer	>100,000	Hours	Indexer Max. load=	7825	in.-lbs.

Output Clutch

11S-SD

Minimum Torque Setting 2,300 in.-lbs. Select Torque Setting 2,300 in.-lbs.

Camshaft Torque= 605 in.-lbs. Motor Rated Speed 1800 rpm Optimal Gear Ratio 30/1

Camshaft RPM...= 60 RPM Motor Speed with Selected Ratio 1800 rpm

Reducer Model	Ratio	Side	Worm	Mounting	Motor Adapter	Reducer Service Factor	2.4
CAMCO R225	30	1	LD	C	NEMA-56C	1450 in-lbs@ 1750 RPM	80%
Motor Reducer	none	1 / 1 Ratio			NONE	Input Reducer SF	

Application Calculated Hp. 0.72 HP.

Select Motor Type AC Variable Speed C-Face

1 HP, 230/460V/60Hz 3 Ø, 1800 RPM. NEMA-56C

Index time at rated motor speed. 0.500 Seconds

Package Description:

CAMCO 500RGS8H40-180 8 Stop indexer with:
 CAMCO R225 Reducer with 30/1 reduction,
 NEMA-56C Face adapter and coupling,
 Reducer mounting C, SIDE 1, LD worm

1 HP, 230/460V/60Hz 3 Ø, 1800 RPM. NEMA-56C Motor
 11S-SD Output overload clutch with 2300 in-lb torque setting

Representative:	DE-STA-CO
Address:	1444 South Wolf Road
Address:	none
City:	Wheeling
State/Province:	Illinois
Zip Code:	60090
Country:	USA
Contact:	CAMCO
Title:	
Phone:	
Fax:	
email:	

#N/A

All applications should be verified by Gold sizing software before orders are entered.

Dimensions and technical information are subject to change without notice.



For more information or to place an order call 1-800-645-5207 or camco@destaco.com

destaco.com

Servo-Mechanical Example

CAMCO software can also be used to size servo-driven indexers such as the 115RSD Rotary Servo Drive and Indexers with constant-lead cams. The following illustrations show input and output data for a typical servo-driven application.



115RSD Rotary Servo Drive

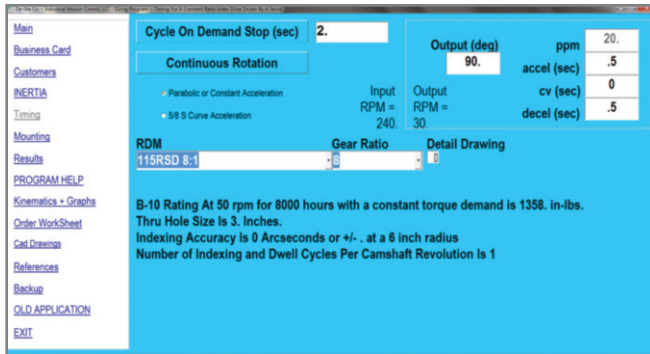

Servo Application Input Screen

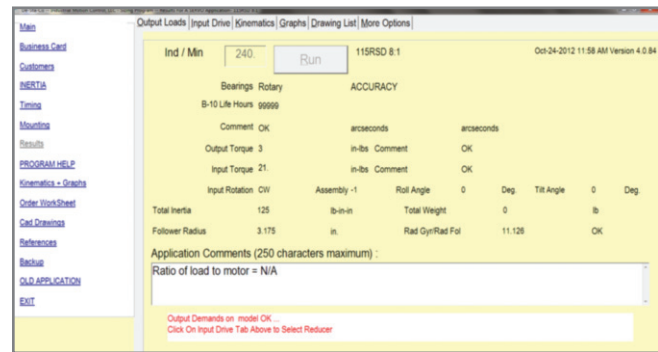

Servo Application Output Screen

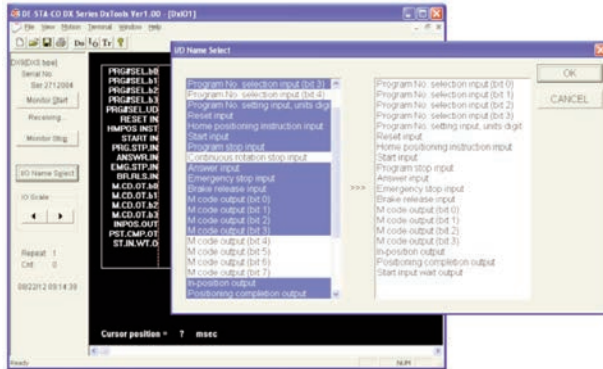

I/O status of host component and can be checked

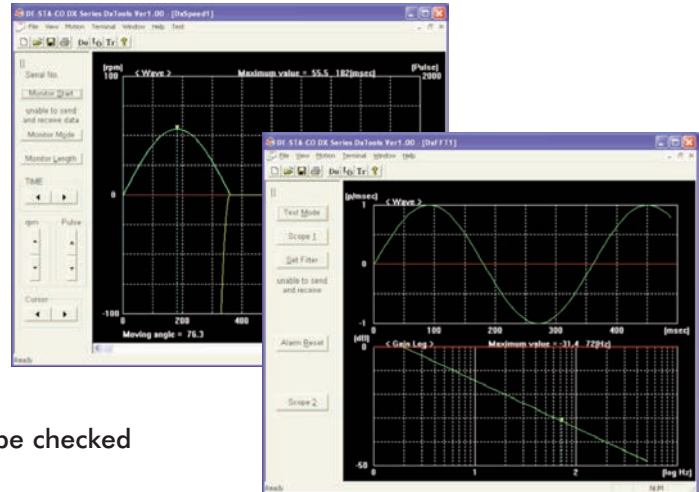

Dimensions and technical information are subject to change without notice.

Nomenclature

Terms used for Engineering Calculations

Symbol	Units	Description	Symbol	Units	Description
β	deg	Index Period	R_f	mm [in]	Friction Force Radius
μ	–	Coefficient of Friction	R_s	mm [in]	Radius to Station Center
B_{10}	Nm [in-lbs]	Basic Dynamic Capacity of the Indexer at a Defined Index Rate	R_w	mm [in]	Radius to Point of Work Load Application
C	–	Constant Velocity Load Adjustment Factor	S	–	Number of Stops or Stations per One Revolution of the Output
C_a	–	Motion Acceleration Factor	SF	–	Service Factor 1.3
C_d	–	Factor for Calculating Output Torque	S_x	mm [in]	Linear Index Distance
C_v	–	Motion Velocity Factor	T_c	Nm [in-lbs]	Camshaft Torque
D_d	mm [in]	Dial Plate Diameter	T_f	Nm [in-lbs]	Friction Torque at the Output
D_n	mm [in]	Diameter of Driven Pulley or Gear	T_i	Nm [in-lbs]	Inertia Torque at the Output
D_r	mm [in]	Diameter of Drive Pulley or Gear	T_o	Nm [in-lbs]	Total Output Torque
D_s	mm [in]	Pitch Diameter of Drive Sprocket(s)	T_s	Nm [in-lbs]	Static Torque
D_t	mm [in]	Pitch Diameter of Take-up Sprocket(s)	T_w	Nm [in-lbs]	Work Torque at the Output
E	–	Reducer Efficiency	t	sec	Total Cycle Time ($t_1 + t_2$)
F	–	Percent of Constant Velocity	t_1	sec	Dwell Time
F_s	–	Index Rate Factor	t_2	sec	Index Time
G_i	–	Input Gear Ratio	W_c	kg [lbs]	Weight of Chain and Fixtures
G_o	–	Output Gear Ratio	W_d	kg [lbs]	Weight of Dial Plate
k	mm [in]	Radius of Gyration	W_{ds}	kg [lbs]	Weight of Drive Sprocket(s)
K_f	–	Factor for Calculating Cam Shaft Torque Due to Friction and Work Load on Output	$Wk^2_{(ext.)}$	kgm ² [lbs-in ²]	External Weight Moment of Inertia at Output
K_i	–	Factor for Calculating Cam Shaft Torque due to Inertia at Output	$Wk^2_{(int.)}$	kgm ² [lbs-in ²]	Internal Weight Moment of Inertia at Output
M	–	Type of Cam (Symbol) Integer Number 1, 2 or 3	$Wk^2_{(cl.)}$	kgm ² [lbs-in ²]	Clutch Weight Moment of Inertia
N	ind/min	Index Rate	W_n	kg [lbs]	Weight of Driven Pulley or Gear
n	–	Number of Teeth in Conveyor Drive Sprocket	W_p	kg [lbs]	Weight of Total Parts to be Indexed
N_c	RPM	Camshaft Rotation per Minute	W_r	kg [lbs]	Weight of Drive Pulley or Gear
N_m	RPM	Power Source Rotation per Minute (Motors, Line Shaft, etc.)	W_s	kg [lbs]	Weight of Each Station (Fixture & Part)
p	mm [in]	Chain Pitch of Conveyor Sprocket	W_t	kg [lbs]	Weight of Take-up Sprocket(s)
			W_w	kg [lbs]	Work Load
			Y	mm [in]	Dial Plate Thickness

Dimensions and technical information are subject to change without notice.

Inertia Tables

Multiply radius of gyration squared (k^2) by weight to get weight moment of inertia for torque demand calculation.

Radius of Gyration

Body With Central Axis of Rotation	k^2	Body with Offset Axis of Rotation	k^2
<p>Rectangular Prism or Plate Rotating about its Central Perpendicular Axis</p>	$\frac{A^2 + B^2}{3}$	<p>Rectangular Prism or Plate Rotating about a Perpendicular Offset Axis</p>	$\frac{A^2 + B^2}{3} + H^2$
<p>Long Thin Rod of any Cross Section Rotating about its Central Perpendicular Axis</p>	$\frac{L^2}{3}$	<p>Long Thin Rod of any Cross Section Rotating about a Perpendicular Offset Axis</p>	$\frac{L^2}{3} + H^2$
<p>Solid Cylinder or Disc Rotating about its Own Axis</p>	$\frac{R^2}{2}$ or $\frac{D^2}{8}$	<p>Solid Cylinder or Disc Rotating about an Offset Parallel Axis</p>	$\frac{R^2}{2} + H^2$
<p>Hollow Cylinder or Flat Ring Rotating about its Own Axis</p>	$\frac{R^2 + r^2}{2}$	<p>Hollow Cylinder or Flat Ring Rotating about an Offset Parallel Axis</p>	$\frac{R^2 + r^2}{2} + H^2$
<p>Solid Cylinder Rotating about its Diameter at Mid-Length</p>	$\frac{L^2}{3} + \frac{R^2}{4}$	<p>Solid Cylinder Rotating about an Offset Axis Parallel to its Diameter</p>	$\frac{L^2}{3} + \frac{R^2}{4} + H^2$
<p>Hollow Cylinder Rotating about its Diameter at Mid-Length</p>	$\frac{L^2}{3} + \frac{R^2 + r^2}{4}$	<p>Hollow Cylinder Rotating about an Offset Axis Parallel to its Diameter</p>	$\frac{L^2}{3} + \frac{R^2 + r^2}{4} + H^2$

Dimensions and technical information are subject to change without notice.



Kinematic Calculations - Metric

In the "Cam Design Manual for Engineers, Designers, and Draftsmen," Clyde H. Moon developed factors for quickly calculating maximum velocity and maximum acceleration for an application. These are known as "Moon factors." For a Modified Sine Motion, the Moon factors are **$C_v = 1,7596$ and $C_a = 5,5280$** . These factors are unitless and a chart of various Moon factors are listed on page XX.

If we move an object 250 mm (0,250m) in 0,3 seconds using a Modified Sine Motion, the maximum velocity (at mid-point of index) is:

$$V_{\max} = \frac{C_v \times \text{Displacement}}{t_2}$$

$$= \frac{1,7596 \times 0,25}{0,3} = 1,466 \text{ m/s}$$

The maximum acceleration is:

$$A_{\max} = \frac{C_a \times \text{Displacement}}{t_2^2}$$

$$= \frac{5,528 \times 0,25}{0,3^2} = 15,36 \text{ m/s}^2$$

$$\text{or} = 15,36 / 9,81 = 1,56 \text{ g's}$$

It can also be used for calculating rotational g-force (also known as centrifugal force):

Index a 8 kg object 90° at a 1 m radius in 0,5 seconds:

$$\text{Force}_{\text{centrifugal}} = \text{Mass} \times a_{\text{radial max}}$$

$$= \text{Mass} \times \omega_{\text{max}}^2 \times R$$

$$= 8 \text{ kg} \times \left(\frac{1,7596 \times 90^\circ \times \pi}{180^\circ \times 0,5 \text{ sec}} \right)^2 \times 1 \text{ m}$$

$$= 244,5 \text{ N or } \frac{244,5}{(8 \times 9,81)} = 3,12 \text{ g's}$$

The tangential force component is:

$$\text{Force}_{\text{tangential}} = \text{Mass} \times a_{\text{max}}$$

$$= \frac{8 \text{ kg} \times 5,528 \times 1 \text{ m} \times 90^\circ \times \pi}{180^\circ \times 0,5^2}$$

$$= 277,9 \text{ N or } \frac{277,9}{8 \text{ kg}} / 9,81 = 3,54 \text{ g's}$$

Kinematic Calculations - Imperial

In the "Cam Design Manual for Engineers, Designers, and Draftsmen," Clyde H. Moon developed factors for quickly calculating maximum velocity and maximum acceleration for an application. These are known as "Moon factors." For a Modified Sine Motion, the Moon factors are **$C_v = 1.7596$ and $C_a = 5.5280$** . These factors are unitless and a chart of various Moon factors are listed on page 24.

If we move an object 12 inches in 0.3 seconds using a Modified Sine Motion, the maximum velocity (at mid-point of index) is:

$$V_{\max} = \frac{C_v \times \text{Displacement}}{t_2}$$

$$= \frac{1.7596 \times 12}{0.3} = 70.4 \text{ inches/second}$$

The maximum acceleration is:

$$A_{\max} = \frac{C_a \times \text{Displacement}}{t_2^2}$$

$$= \frac{5.528 \times 12}{0.3^2} = 737 \text{ inches/sec}^2$$

$$\text{or } 737/386.4 = 1.9 \text{ g's}$$

It can also be used for calculating rotational g force (also known as centrifugal force):

Index a 15-lb. object at a 40 inch radius 90 degrees in 0.5 seconds:

$$\text{Force}_{\text{centrifugal}} = \text{Mass} \times a_{\text{radial max}}$$

$$= \text{Mass} \times \omega_{\text{max}}^2 \times R$$

$$= \frac{15}{386.4} \times \left(\frac{1.7596 \times 90^\circ \times \pi}{180^\circ \times 0.5} \right)^2 \times 40$$

$$= 47.4 \text{ lbs. or } \frac{47.4}{15} = 3.2 \text{ g's}$$

The tangential force component is:

$$\text{Force}_{\text{tangential}} = \text{Mass} \times a_{\text{tmax}}$$

$$= \frac{15}{386.4} \times \frac{5.528 \times 40 \times 90^\circ \times \pi}{180^\circ \times 0.5^2}$$

$$= 53.9 \text{ lbs. or } \frac{53.9}{15} = 3.6 \text{ g's}$$

K_i K_f Tables & Moon Factor Tables (C_v and C_a)

Values listed are for type 1 units, multiply values by 2 for type 2 units. For motions with constant velocity, multiply K factor by the adjustment factor listed below.

Number of Stops	Index Period (Modified-Sine Motion)													
	90°		120°		150°		180°		210°		270°		330°	
	K _i	K _f	K _i	K _f	K _i	K _f	K _i	K _f	K _i	K _f	K _i	K _f	K _i	K _f
1	3.94	7.04	2.96	5.28	2.36	4.22	1.97	3.52	1.69	3.02	1.31	2.35	1.07	1.92
2	1.97	3.52	1.48	2.64	1.18	2.11	0.99	1.76	0.84	1.51	0.66	1.17	0.54	0.96
3	1.31	2.35	0.99	1.76	0.79	1.41	0.66	1.17	0.56	1.01	0.44	0.78	0.36	0.64
4	0.99	1.76	0.74	1.32	0.59	1.06	0.49	0.88	0.42	0.75	0.33	0.59	0.27	0.48
6	0.66	1.17	0.49	0.88	0.39	0.70	0.33	0.59	0.28	0.50	0.22	0.39	0.18	0.32
8	0.49	0.88	0.37	0.66	0.30	0.53	0.25	0.44	0.21	0.38	0.16	0.29	0.13	0.24
10	0.39	0.70	0.30	0.53	0.24	0.42	0.20	0.35	0.17	0.30	0.13	0.23	0.11	0.19
12	0.33	0.59	0.25	0.44	0.20	0.35	0.16	0.29	0.14	0.25	0.11	0.20	0.09	0.16
16	0.25	0.44	0.18	0.33	0.15	0.26	0.12	0.22	0.11	0.19	0.08	0.15	0.07	0.12
24	0.16	0.29	0.12	0.22	0.10	0.18	0.08	0.15	0.07	0.13	0.05	0.10	0.04	0.08
36	0.11	0.20	0.08	0.15	0.07	0.12	0.05	0.10	0.05	0.08	0.04	0.07	0.03	0.05

K_i and K_f Adjustment Factors

For % Constant Velocity	Multiply K factor by
0%	1.00
20%	0.87
25%	0.84
33%	0.80
50%	0.72
66%	0.67
75%	0.64

Constant Velocity Adjustment Factor "C"; Velocity and Acceleration Factors

	% Constant Velocity								
	0%	5%	10%	20%	25%	33%	50%	66%	75%
C	1.000	1.014	1.033	1.085	1.120	1.193	1.449	1.959	2.548
C _v	1.7596	1.6952	1.6354	1.5275	1.4788	1.4069	1.2753	1.1720	1.1210
C _a	5.5280	5.6060	5.7085	5.9986	6.1943	6.5970	8.0127	10.8295	14.0866



Accuracy

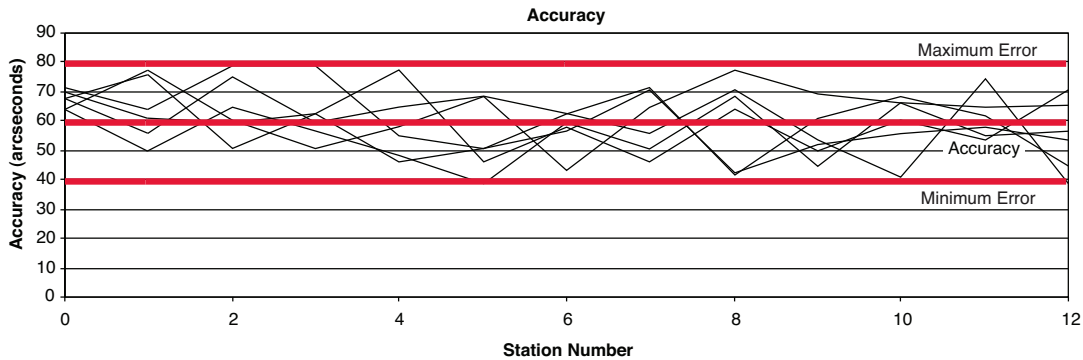

DE-STA-CO intentionally chooses to state the Maximum Error as the indexer’s worst possible accuracy. While some index drive manufacturers use the average as their stated accuracy and decline to state the repeatability, DE-STA-CO takes a more conservative approach.

Measurement Method

The output angular error of an index drive is measured using a laser collimator mounted to a precision rotary table. The laser collimator is accurate to 2 arc seconds

and repeatable to 1 arc second. The indexer will make 3 to 6 complete turns of its output and accuracy measurements are recorded. The accuracy is the mean between the maximum and minimum error. The repeatability is one-half the difference between the maximum and minimum error.

Upon request, DE-STA-CO can provide accuracy reports for a particular indexer per ANSI/ASME B89.3.4M

Vibration

Cam-actuated index drives are frequently chosen because of their stability in dwell, especially when operating at high speeds. It is important to ascertain that the entire system is well designed to prevent any unwanted vibrations. Vibration is a function of the index time, index rate, friction (dampens the system), input and output connections, torsional spring rate and the natural frequency of the indexer and driven members.

One simple method to avoid problems is to calculate the ratio of the effective radius of gyration (k) to the cam follower pitch radius. This method does not always produce consistent results. For example, a system with a large effective radius of gyration can be run at slow speed and there are no observable vibrations in dwell. Friction also helps prevent vibration, as in the case of precision link conveyor systems.

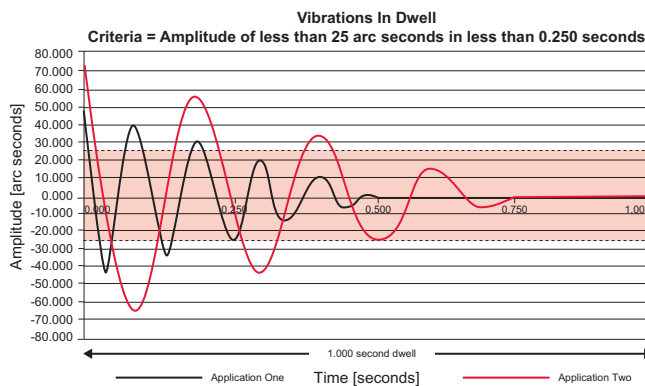

DE-STA-CO has developed stability criteria that effectively predict vibration effects. The criteria require that the amplitude of the vibration must be less than 25 arc seconds in 25% of the dwell time. DE-STA-CO’s loading programs automatically check for this prerequisite.

Vibration can be avoided by following the recommended input and output connection methods and confirming the vibration effect of the specific application using DE-STA-CO’s loading software program.

Dimensions and technical information are subject to change without notice.

Type I and Type II Indexers Explained

Some index drives produce two indexes for every one rotation of input shaft. This is due to the geometric constraints of certain motion period and output displacement combinations. If there is a double index, we call this a **Type II indexer** (and $M = 2$). If there is only one index per revolution of input camshaft, we

call this a **Type I indexer** (and $M = 1$). **Type I indexers are more common.** If CAMCO has a Type II indexer with a "270 degree motion period", the first index is achieved with 135 degrees of real input camshaft rotation ($270 / 2 = 135^\circ$).

Emergency Stop

Emergency stops can occur during any part of the index motion. OSHA and other regulatory agencies would like this stop to occur instantaneously. The laws of physics require that the stop occurs within a finite time – and this time cannot be too extended (for it would defeat the purpose of an emergency stop).

Intuition suggests that the worst possible time for an emergency stop is at mid-motion of the index, at peak output velocity. At that moment we have the greatest amount of kinetic energy. The mathematics of motion curves prove otherwise. For a particular type of motion, computer software analysis is the best method for determining the worst case scenario. Upon request, DE-STA-CO engineering staff can evaluate and calculate the maximum expected stop times for specific applications and also evaluate the resulting stresses on the cam, cam followers, follower wheel and input components (reducer, motor, clutch and brake). Normal forces on the cam follower must not exceed the vendor's recommended maximum and the cam

and camshaft stress must not exceed the ultimate yield stress of the material (the cam and camshaft are normally designed for fatigue and not strength).

For an application with an Emergency stop requirement, DE-STA-CO recommends that the drive package for an indexer should be a low ratio worm gear drive (10:1 or 15:1) along with a helical primary (5:1 or 5:1). This should be coupled to an air or hydraulic clutch-brake. Wet type or Hydro-viscous type clutch-brakes are recommended due to their low inertia of the cyclic parts and high heat dissipation capability. In contrast, dry type clutch-brakes wear quickly. In an Emergency stop mode, the clutch-brake disengages the motor since the low-ratio gear combination (low ratio worm and helical primary combination) will be intentionally back driven. The brake then dissipates the kinetic energy of the Emergency stop. For further details, please contact your DE-STA-CO sales representative or DE-STA-CO application engineer.

Mechanical Overload Protection

DE-STA-CO offers a wide variety of output overload clutches and input overload clutches designed to protect the indexer drive. Overload clutches are recommended due to the nature of indexing. At the very beginning of an index, the input displacement is large while the output displacement is miniscule. At that precise moment, the instantaneous gear ratio of the drive is extremely high – almost infinite. Small amounts of input torque produce tremendous output torque. If there are any machine components or product parts jamming the mechanism (dial, conveyor belt or other linkage), the tooling or the index drive itself could be damaged. DE-STA-CO clutches are offered in a wide assortment of geometries to accommodate shaft-to-shaft, flange-to-shaft and dial applications. DE-STA-CO also offers internal overload clutches on certain models to protect the clutch from foreign contamination. DE-STA-CO overload clutches for indexing applications have a single position reset point of

ensure accuracy and repeatability. Typically, proximity switches are mounted adjacent to the clutch to sense an overload condition (sense the detector plate movement) and shut down the machinery.



Lubrication

Indexers

DE-STA-CO Index drives are normally shipped without oil to avoid possible leakage during transit. Each particular index drive mounting position requires a different oil level. A “bulls eye” type oil level sight gauge is supplied with each index drive. The unit should be filled with oil until the level reaches the middle of this sight gauge.

Lubricating oils for use in an index drive should be high quality, well-refined petroleum oils or synthetic lubricants with extreme pressure additives. They may be subject to high operating temperatures, so they must have good resistance to oxidation. The lubricant must meet these specifications: MIL-PRE-2105E or SAE 80W-140, ISO 220 or AGMA 5 with EP (extreme pressure) additives.

Some units use grease rather than oil. In this case, the unit will be shipped with the grease. Generally, DE-STA-CO uses a lithium grease such as Mobilith AW-2.

Gear Reducers

Lubricating oils for gear reducers should also be of high quality, well-refined petroleum oils. These oils should meet AGMA 8 or 8A specifications or ISO 680 or 1000 specifications. Oils with EP additives should not be used if the reducer contains bronze parts.

If you have any questions regarding lubricants, please contact DE-STA-CO’s engineering department.

Axial, Radial & Moment Capacity

In addition to the B_{10} capacity, which is based on the cam follower capacity, an index drive also has a load capacity based on the bearings supporting the output. Several load conditions can be present in an application:

- **Axial or Thrust Capacity** is the maximum balanced load the indexer's output bearing can support. Due to the use of large bearings, this load capacity generally does not need to be addressed in normal applications.
- **Radial Capacity** is the maximum side load of the output bearing, applied through and perpendicular to the axis of rotation.
- **Moment Capacity** is the maximum overturning or unbalanced load capacity of the output bearing.

The Axial, Radial and Moment capacities for most indexers are listed in the appropriate product section.

Exceeding the capacity of the output bearing with any of these types of forces can cause permanent deformation of the cam, fractured cam followers, or output bearing failure. Contact DE-STA-CO engineering for analysis of application with special requirements regarding any of these conditions.

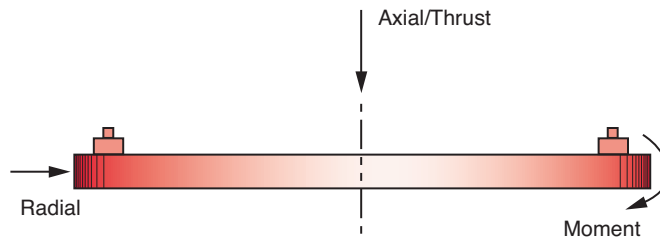

Input Considerations

All load calculations are based on a constant velocity input (camshaft speed) during the index. If there are any speed variations on the input shaft, these variations are amplified on the output shaft (velocities are accelerated and accelerations become jerk). It is very important to have a controlled motor speed and a reducer ratio sufficient to dampen any input speed variations. If input belts are used, they must be tightened to prevent any slip or belt jumping when

positive torque changes to negative torque (input shafts typically see both positive and negative torque in an indexing application). Pulleys should be maximized to the largest diameter that can fit on the camshaft. Adjustable tensioning idler pulleys are highly recommended. If you have any questions regarding input speed control, please contact your local DE-STA-CO sales representative or DE-STA-CO application engineer.

Output Considerations

Indexing always imparts positive and negative torques on the driven members. All connections should be tight and doweled whenever possible. Shaft coupling connections should have an interference fit and not

depend on the keyway for tightness, as any clearance in the key stock or keyways will eventually cause the connection to loosen.



Weights & Oil Capacity

Right Angle

Model	Weight (lbs)	Weight (kg)	Oil Capacity (quarts)	Oil Capacity (liters)
301RA	15	7	C/F	C/F
400RA	33	15	1	1
401RA	55	25	1	1
512RA	80	36	2	2
662RA	160	73	6	6
663RA	130	59	4	4
900RA	220	100	6	6
1200RA	850	386	C/F	C/F

Overload Clutches

Model	Weight (lbs)	Weight (kg)
0.39	5	2
2.3	10	5
4	17	8
6	25	11
7.8	20	9
11	40	18
18	75	34
35	57	26
31	123	56

Right Angle

Model	Weight (lbs)	Weight (kg)	Oil Capacity (quarts)	Oil Capacity (liters)
250P	18	8	1	1
387P	55	25	2	2
512P	135	61	5	5
662P	430	195	10	10
900P	750	340	20	19
1200P	1,100	499	48	45
1800P	3,000	1,361	95	90
P200	20	9	C/F	C/F
P325	60	27	2	2
P400	85	39	4	4
P500	110	50	4	4
P600	160	73	6	6
P750	500	227	14	13
P1050	750	340	24	23
P1400	1,100	499	52	49
P1700	3,000	1,361	76	72

Torq Gard Clutches

Model	Weight (lbs)	Weight (kg)
TG3	2	1
TG6	2	1
TG20	3	1
TG60	6	3
TG200	12	5
TG400	43	20
TG800	43	20

Roller Gear

Model	Weight (lbs)	Weight (kg)	Oil Capacity (quarts)	Oil Capacity (liters)
350RG	35	16	1	1.4
500RG	350	159	5	4.7
600RG	390	177	7	7
700RG	400	181	10	9.5
FD-100	10	5	7 oz	0.2
FD-162	50	23	2	2
FD-200	115	52	4	4
FD-250	125	57	7	7
FD-300	300	136	10	9
FD-451	560	254	12	11
FD-501	900	408	22	21

Cambots

Model	Weight (lbs)	Weight (kg)	Oil Capacity (quarts)	Oil Capacity (liters)
150RPP	45	20	2.5	2.4
300RPP	110	50	4	4
500RPP	300	136	10	9
900RPP	575	261	48	45
WBD-101	C/F	C/F		
WBD-201	C/F	C/F		
WBD-301	C/F	C/F		
WBD-401	C/F	C/F		
140LPP	55	25		
240LPP	80	36		
380LPP	200	91		
4120LPP	340	154		
LPP-101	C/F	C/F		
LPP-201	C/F	C/F		
LPP-301	C/F	C/F		
LPP-401	C/F	C/F		

These units are grease-filled. Consult the model-specific service manual for lubrication information.

Dimensions and technical information are subject to change without notice.

Weights & Oil Capacity

(continued)

Roller Dial

Model	Weight (lbs)	Weight (kg)	Oil Capacity (quarts)	Oil Capacity (liters)
80RDM	19	8.6	Grease-Filled	
601RDM	70	32	2	2
902RDM	130	59	3	3
1100RDM	C/F	C/F	8	8
1305RDM	305	138	9	9
1800RDM	1,400	635	36	34
PN300	50	23	4	4
PN400	C/F	C/F	8	8
PN500	C/F	C/F	12	11
ED200	300	136	6	6
ED420	750	340	20	19
ED810	1,200	544	20 gal	76
ED1440	3,000	1,361	30 gal	114
ED3240	9,500	4,309	35 gal	132
425RD	110	50	2	2
800RD	450	204	5	5
1301RD	1,000	454	14	13
1801RD	2,400	1,089	36	34
122	200	91	16	15
242	800	363	32	30
362	1,500	680	56	53
482	6,000	2,722	33 gal	125
722	8,750	3,969	42 gal	159

Gear Reducers

Model	Weight (lbs)	Weight (kg)	Oil Capacity (quarts)	Oil Capacity (liters)
R180	10	5	5 oz	.15
R225	25	11	1	1
R260	25	11	1	1
7300C	89	40	1.5	1.4
7350C	123	56	3.5	3.3
7400C	180	82	4	3.8
7500C	307	139	7	6.6
7600C	433	196	11	10
7700C	625	283	20	19
7800C	755	342	26	25
71000C	1,625	737	56	53
20CDSF	35	16	13 oz	0.4
26CDSF	55	25	2	1.9
6SF	85	39	2	1.9

Miniature Roller Gear

Model	Weight (lbs)	Weight (kg)	Oil Capacity (ounces)	Oil Capacity (liters)
40RG	3	6	6	0.2
50RG	18	8	16	0.5
70RG	25	11	20 - 24	0.6 - 0.7
80RG	65	29	30 - 38	1.0 - 1.1
110RG	-	-	C/F	C/F

E Series

Model	Weight (lbs)	Weight (Kg)	Oil Capacity (gallons)	Oil Capacity (Liters)
950E	5,000	2,268	10 gal	38
1150E	5,500	2,495	25 gal	95
1550E	6,000	2,722	40 gal	152
2050E	18,000	8,165	45 gal	171
2750E	54,000	24,494	75 gal	285

Dimensions and technical information are subject to change without notice.

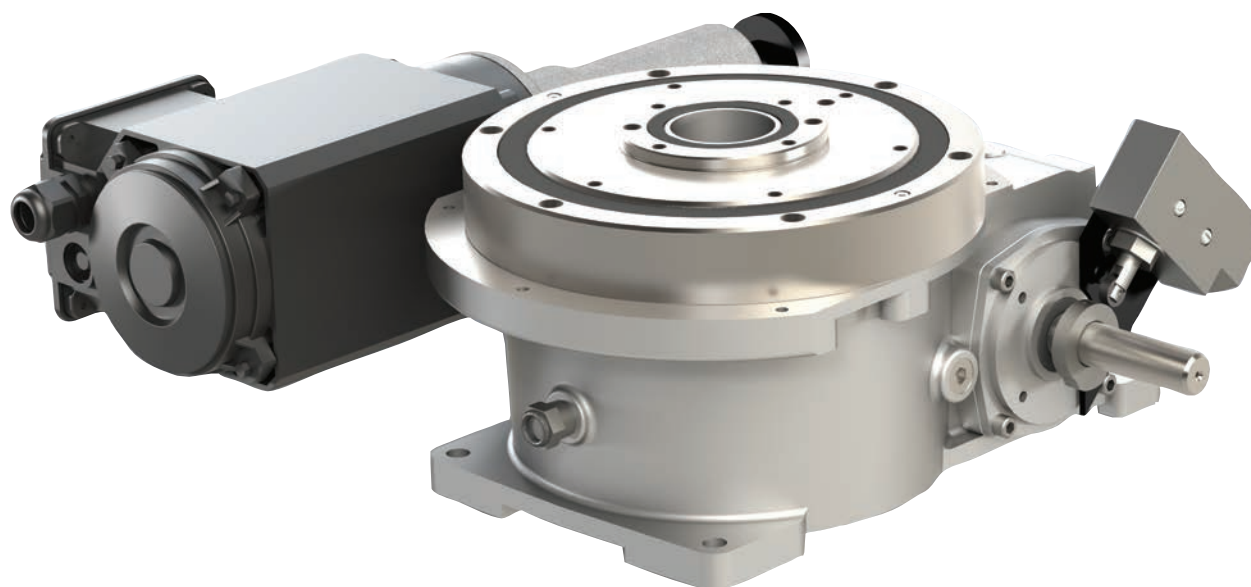

Features:

The **CAMCO RDM Series Index Drive** is ideal for rotary dial applications with features including:

- Large output Mounting Surface supported by 4-point contact bearing offering superior thrust and moment capacity
- Large Center Thru Hole
- Low Profile
- Complete, Motorized Drive Packages
- Optional Output Overload Clutch

Table of Contents

How to Order	40
80RDM	42
601RDM	44
902RDM	46
1100RDM	48
1305RDM	50
1800RDM	52

Dimensions and technical information are subject to change without notice.



RDM Series How to Order

Base Model Description

- 80RDM** w/ R180 reducer & 1/3 hp AC motor (220/440V)
- 601RDM** w/ R180 reducer & 1/3 hp AC motor (220/440V)
- 902RDM** w/ R225 reducer & 1 hp AC motor (220/440V)
- 1100RDM** w/ KH47 reducer & 1-1/2 hp AC motor (220/440V)
- 1305RDM** w/ 7300C reducer & 2 hp AC motor (220/440V)
- 1800RDM** w/ 7400C reducer & 3 hp AC motor (220/440V)

Control Description

- 1** 1 hp 120V 80RDM,601RDM & 902RDM only
- 2** 1 hp 240V 80RDM,601RDM & 902RDM only
- 3** 1 hp 440V 80RDM,601RDM & 902RDM only
- 4** 2 hp 240V 1100RDM & 1305RDM only
- 5** 2 hp 440V 1100RDM & 1305RDM only
- 6** 3 hp 240V 1800RDM only
- 7** 3 hp 440V 1800RDM only



Motion	Stops	Index Period
A	2	330
B	3	330
C	4	330
D	6	330
E	8	330
F	12	330
G	16	330

Index Mounting
(See Figure 3)

- 1**
- 2**
- 3**
- 4**
- 5**
- 6**

Reducer Ratio
1100RDM

	A	B	C	D	E	F	G
Ratio	15	20	25	30	40	50	60
Value	15.86	19.58	24.06	29.37	39.61	48.95	56.83

Reducer Mounting
(See Figure 4)

- | | |
|---|---|
| A | J |
| B | K |
| C | L |
| D | M |
| E | N |
| F | P |
| G | R |
| H | S |

Signal Switch

- | | | | |
|---|------------|---|---------|
| M | Mechanical | R | Reducer |
| D | Double | S | Shaft |
| P | Proximity | | |

Signal Switch Side
(See Figure 2)

Example: MR, MS, DR, DS, PR or PS

Note about signal switch options:

- a) Mechanical is a single switch with cam.
- b) Proximity option is a mounting bracket for 8 or 12 mm proximity switch. A proximity switch will not be supplied. Cam supplied as target.

Other Motions (stops and index periods) available. Contact your DE-STA-CO sales representative for more information.

Input Shaft Configuration/Rotation (Figure 1)

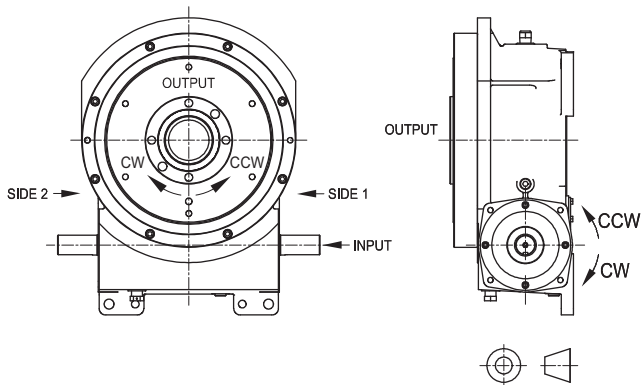

Relative Rotation for Right Hand Cam:

CW Input Side 1 CCW Output

CCW Input Side 2 CW Output

NOTE: Input can be driven in either direction

Signal Switch Mounting Position (Figure 2)

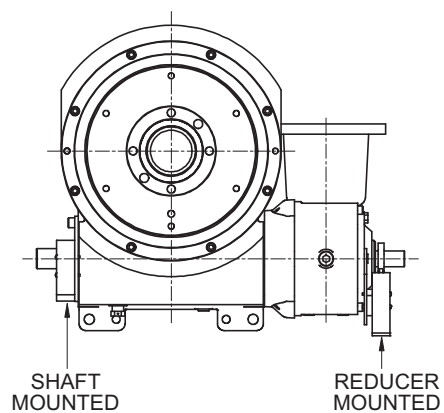

Dimensions and technical information are subject to change without notice.

Input/Output Orientation (Figure 3)

OVOI (output vertical, over input)	OVUI (output vertical, under input)	OHOI (output horizontal, over input)	OHUI (output horizontal, under input)	H-S1-UP (output horizontal, side 1 up)	H-S2-UP (output horizontal, side 2 up)

Gear Reducer Mounting Positions (Figure 4)

		Mounting "A"		Mounting "B"	
		RD Worm	LD Worm	RD Worm	LD Worm
SIDE 1					
		Mounting "C"		Mounting "D"	
		RD Worm	LD Worm	RD Worm	LD Worm
SIDE 1					
SIDE 2					

Dimensions and technical information are subject to change without notice.

80RDM Standard Dimensions

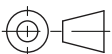
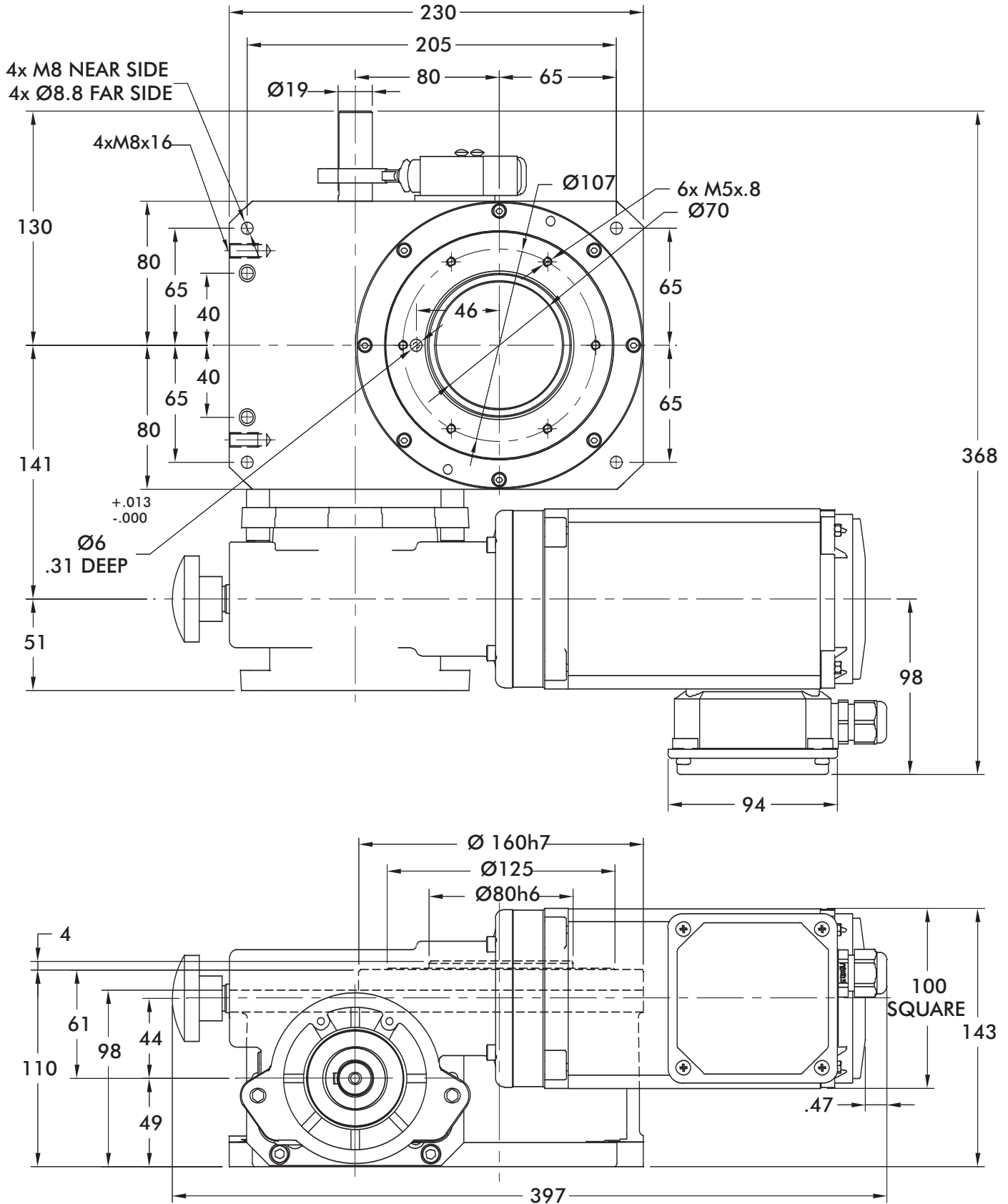

Unless otherwise noted, all dimensions are in mm.

Dimensions and technical information are subject to change without notice.



80RDM Product Overview and Technical Specifications

Maximum Inertia x 1000 [lb-in ²] for standard package							
Stops	Motion Time [seconds]						
	0.458	0.611	0.764	0.917	1.222	1.528	1.833
2	0	1	2	5	10	16	23
3	1	3	7	11	21	32	47
4	2	6	13	23	46	74	104
6	5	13	28	43	84	137	191
8	7	15	25	39	76	127	191
12	17	34	57	88	170	191	191
16	16	31	52	79	153	191	191
Reducer Ratio							
	15	20	25	30	40	50	60

Contact your DE-STA-CO sales representative for more information.

Features

- R180 Reducer (Ratios from 15:1 to 60:1)
 - Double Extended Worm Shaft (Input)
 - Worm Shaft Handwheel
- Double Extended Camshaft (Input Shaft)
- Center Thru Hole (70 mm / 2.76 in. Diameter)
- 1/3 hp AC Drive Package with Inverter Duty Motor and IM-pAC AC Drive (up to 60 cpm)
- Cycle Cam and Limit Switch Mounted to Camshaft
- Right Hand Cam
- Universal Mounting Capability

Optional Accessories

- 1/3 hp DC Motor
- Varipak DC Motor Control (up to 30 cpm)
- Stationary Center Post
- Dual Cam and Limit Switch
- Electric Clutch-Brake
- Left Hand Cam

Output Load Capacity (loads carried during index):

- Radial 755 lbs
- Thrust/Axial 1,885 lbs
- Moment 1,885 in-lb

Typical Application

Dial Diameter: 8 in. to 28 in.

Accuracy

±44 arcsec / ±.003" at 14" Radius

Repeatability

±11 arcsec / ±.0007" at 14" Radius

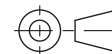
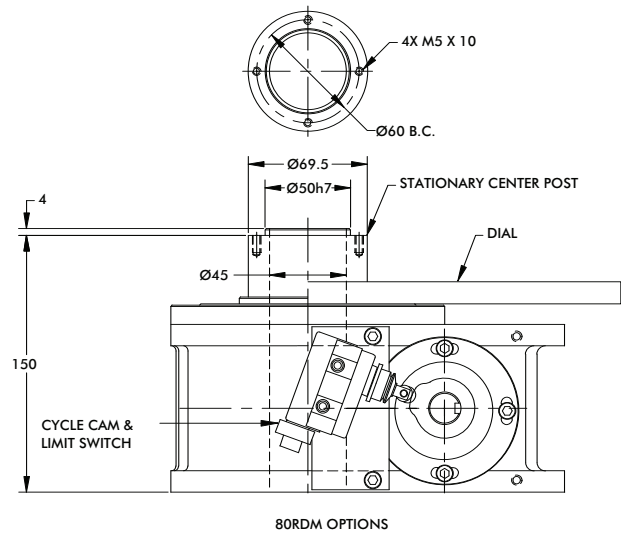

Unless otherwise noted, all dimensions are in mm.

Dimensions and technical information are subject to change without notice.

601RDM Standard Dimensions

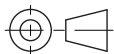
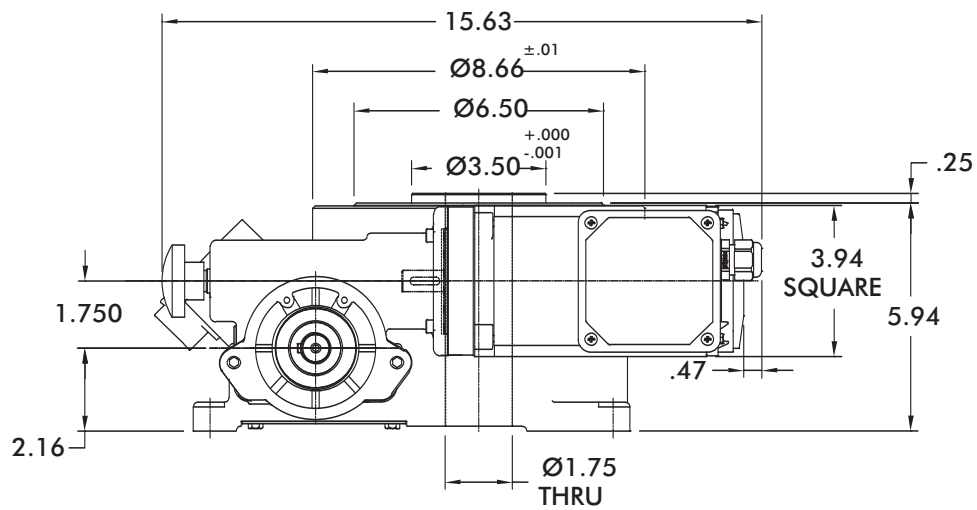
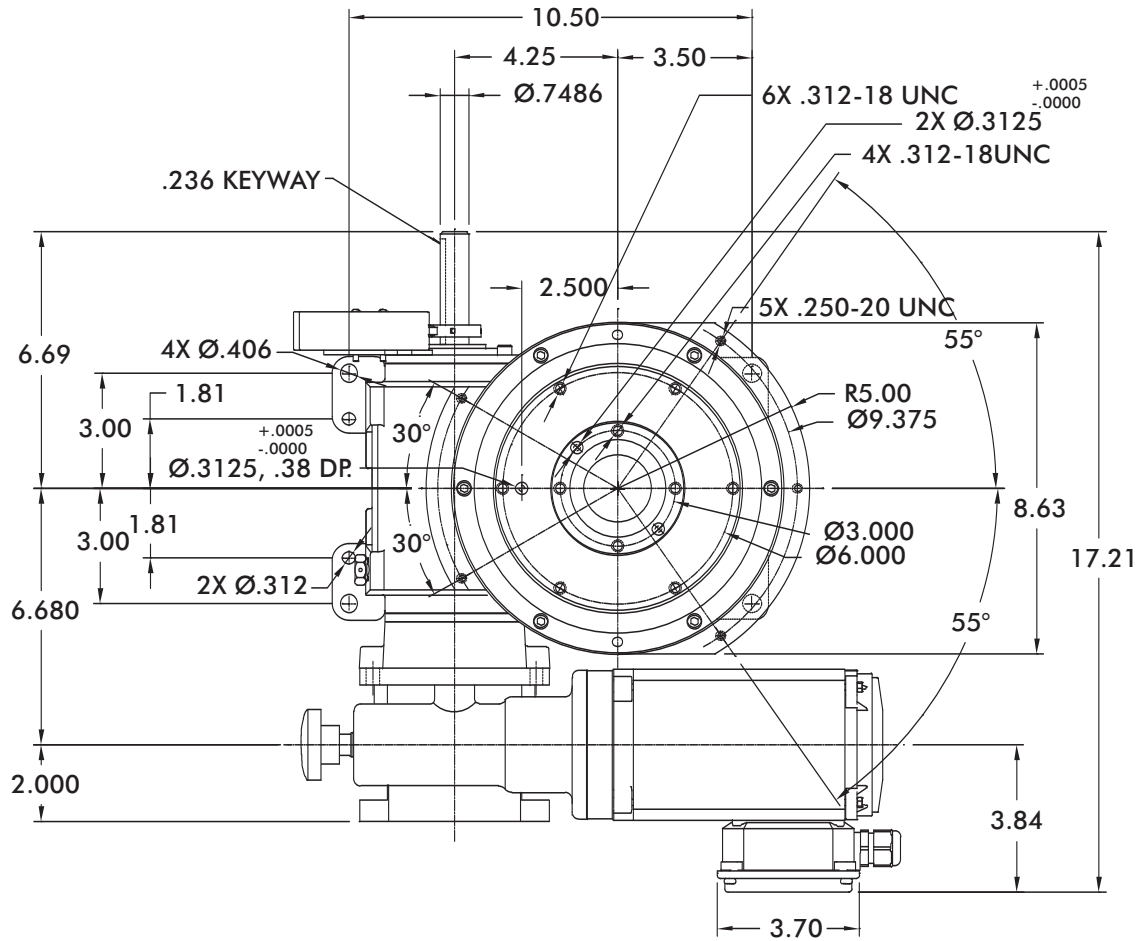

Unless otherwise noted, all dimensions are in inches.

Dimensions and technical information are subject to change without notice.



601RDM Product Overview and Technical Specifications

Maximum Inertia x 1000 [lb-in ²] for standard package							
Stops	Motion Time [seconds]						
	0.458	0.611	0.764	0.917	1.222	1.528	1.833
2	0	1	2	5	11	17	24
3	1	3	7	12	28	42	58
4	2	6	13	23	52	78	106
6	5	14	28	51	112	168	228
8	10	25	51	90	199	299	406
12	22	57	115	204	449	478	478
16	40	101	205	361	478	478	478
Reducer Ratio							
	15	20	25	30	40	50	60

Other Motions (stops and index periods) available. Contact your DE-STA-CO sales representative for more information.

Features

- R180 Reducer (Ratios from 15:1 to 60:1)
 - Double Extended Worm Shaft (Input)
 - Worm Shaft Handwheel
- Double Extended Camshaft (Input Shaft)
- Center Thru Hole (1.75 in. Diameter)
- 1/3 hp AC Drive Package with Inverter Duty Motor and IM-pAC AC Drive (up to 60 cpm)
- Cycle Cam and Limit Switch Mounted to Camshaft
- Right Hand Cam

Output Load Capacity (loads carried during index):

- Radial 945 lbs
- Thrust/Axial 2,360 lbs
- Moment 3,305 in-lb

Typical Application

- Dial Diameter: 12 in. to 36 in.
- Accuracy ±39 arcsec / ±.003" at 18" Radius
- Repeatability ±10 arcsec / ±.0009" at 18" Radius

Optional Accessories

- 1/3 hp DC Motor
- Varipak DC Motor Control (up to 30 cpm)
- Output Overload Clutch model 4.0D
 - Available Settings (in-lbs): 420, 620, 750, 1150, 1750, 2940, 4000
- Stationary Center Post
- Dual Cam and Limit Switch
- Left Hand Cam
- Relief in Dwell for shot-pin applications

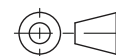
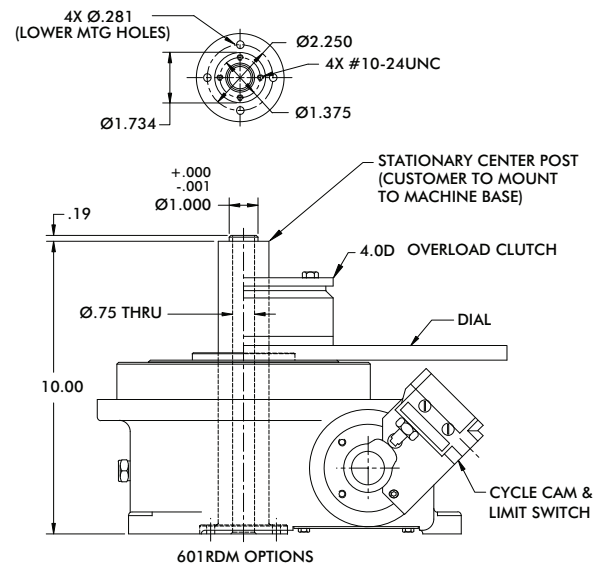

Unless otherwise noted, all dimensions are in inches.

Dimensions and technical information are subject to change without notice.

902RDM Standard Dimensions

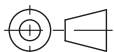
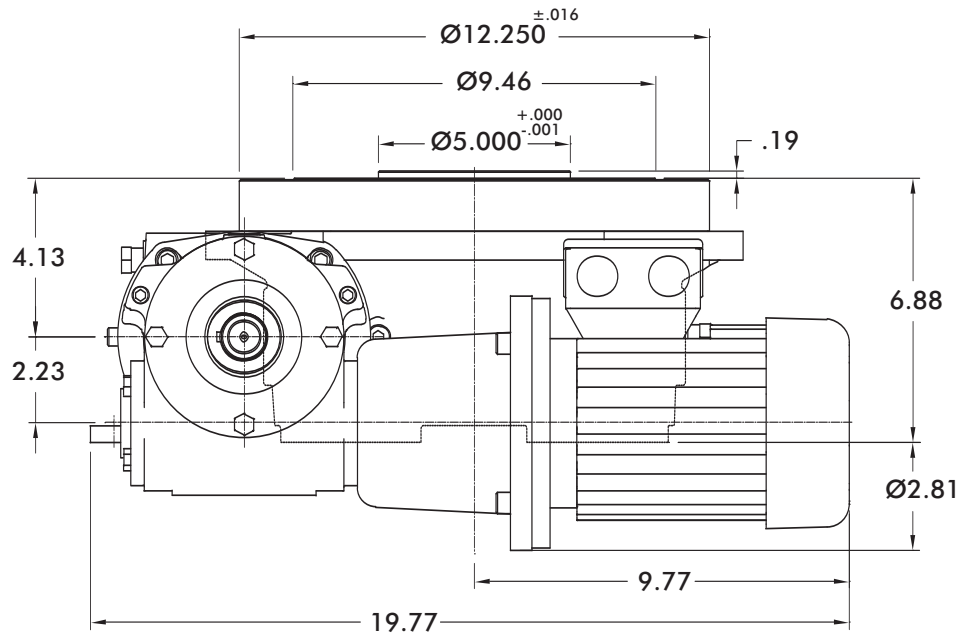
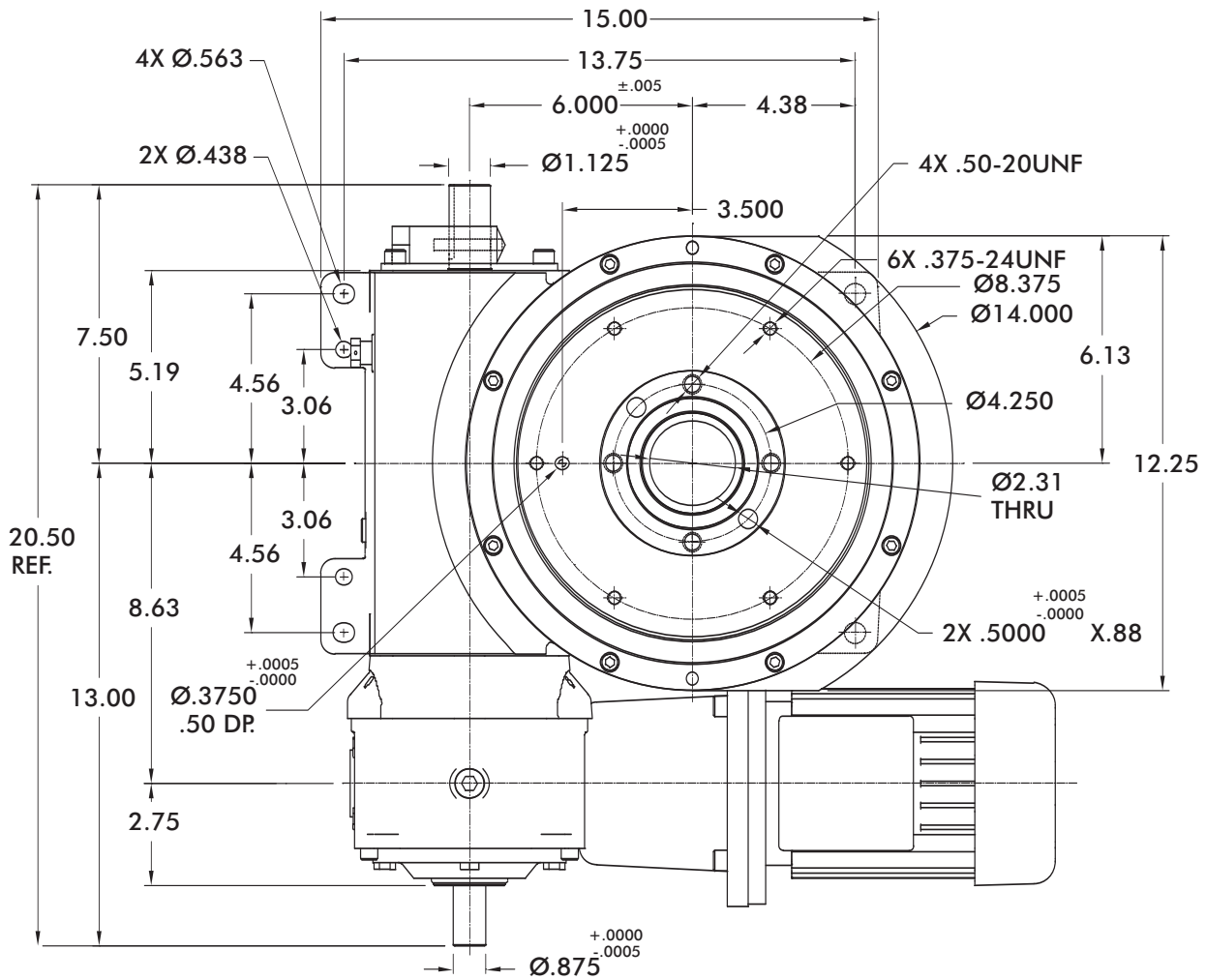

Unless otherwise noted, all dimensions are in inches.

Dimensions and technical information are subject to change without notice.



902RDM Product Overview and Technical Specifications

Stops	Maximum Inertia x 1000 [lb-in ²] for standard package						
	Motion Time [seconds]						
	0.458	0.611	0.764	0.917	1.222	1.528	1.833
2	1	3	7	12	26	40	55
3	4	11	23	41	84	126	174
4	8	20	41	73	150	226	310
6	18	44	90	158	323	485	667
8	32	80	160	282	575	864	1,187
12	73	181	338	487	865	1,352	1,948
16	130	313	506	728	1,295	2,024	2,914
	Reducer Ratio						
	15	20	25	30	40	50	60

Other Motions (stops and index periods) available. Contact your DE-STA-CO sales representative for more information.

Features

- R225 Reducer (Ratios from 15:1 to 60:1)
- Single Extended wormshaft (Standard)
- Double Extended Camshaft (Input Shaft)
- Center Thru Hole (2.25 in. Diameter)
- 1 hp AC Drive Package with Inverter Duty Motor and IM-pAC AC Drive (up to 60 cpm)
- Cycle Cam and Limit Switch Mounted to Camshaft
- Right Hand Cam

Output Load Capacity (loads carried during index):

- Radial 3,540 lbs
- Thrust/Axial 7,000 lbs
- Moment 21,620 in-lb

Typical Application

- Dial Diameter: 20 in. to 48 in.
- Accuracy ±27 arcsec / ±.003" at 24" Radius
- Repeatability ±7 arcsec / ±.0008" at 24" Radius

Optional Accessories

- 1 hp DC Motor
- Varipak DC Motor Control (up to 30 cpm)
- Output Overload Clutch model 7.8D
 - Available Settings (in-lbs): 1400, 1700, 2600, 3200, 4200, 5000, 7200, 10000
- Stationary Center Post
- Dual Cam and Limit Switch
- Base Riser Blocks
- Electric Clutch-Brake
- Left Hand Cam
- Relief in Dwell for shot-pin applications

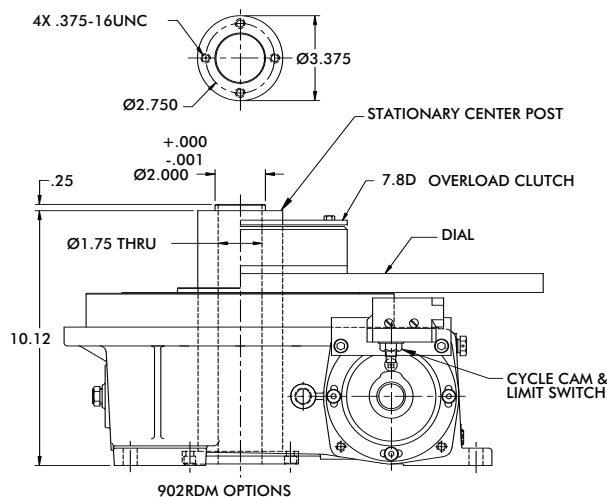

Unless otherwise noted, all dimensions are in inches.

Dimensions and technical information are subject to change without notice.

1100RDM Standard Dimensions

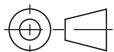
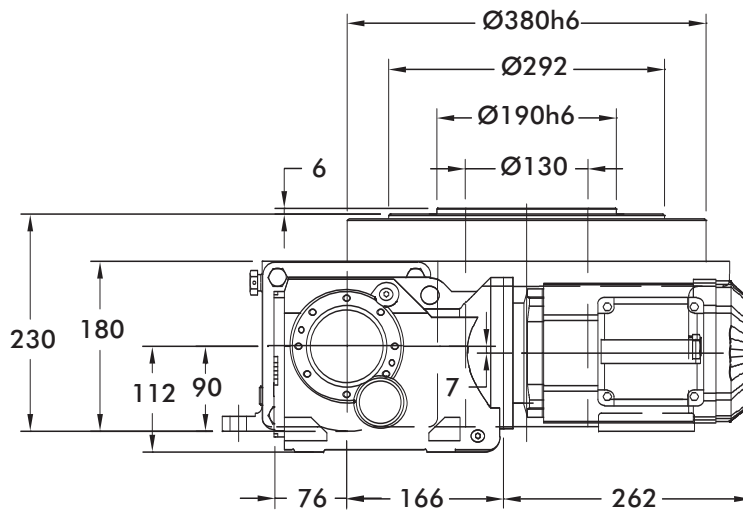
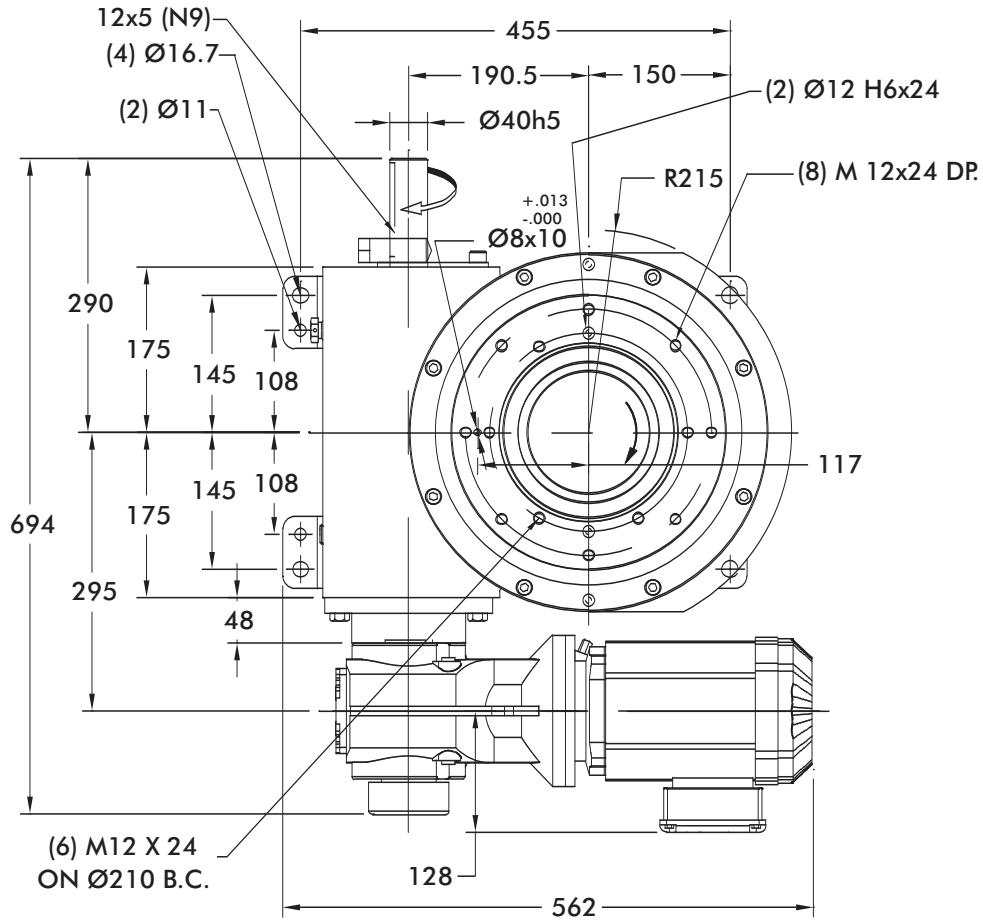

Unless otherwise noted, all dimensions are in mm.

Dimensions and technical information are subject to change without notice.



1100RDM Product Overview and Technical Specifications

Maximum Inertia x 1000 [lb-in ²] for standard package							
Stops	Motion Time [seconds]						
	0.458	0.611	0.764	0.917	1.222	1.528	1.833
2	1	5	11	22	60	117	177
3	6	13	27	52	137	265	400
4	13	27	55	104	270	521	785
6	30	61	120	227	582	1,122	1,688
8	55	111	216	405	1,037	1,995	2,705
12	126	251	488	913	2,335	4,293	5,786
16	225	449	869	1,414	2,659	4,061	5,474
Reducer Ratio							
	15.86	19.58	24.06	29.32	39.61	48.95	56.83

Other Motions (stops and index periods) available. Contact your DE-STA-CO sales representative for more information.

Features

- KH47 Reducer and AC Motor with Optional Brake
- Double Extended Camshaft (Input Shaft)
- Center Thru Hole (130 mm / 5.1 in. Diameter)
- AC drive package with Inverter Duty Motor and Inverter Drive (up to 60 cpm)
- Cycle Cam and Limit Switch Mounted to Camshaft
- Right Hand Cam

Output Load Capacity (loads carried during index):

- Radial 3100 lbs
- Thrust/Axial 8000 lbs
- Moment 28,674 in-lbs

Typical Application

- Dial Diameter: 20 in. to 60 in.
- Accuracy ±22 arcsec / ±.003" at 30" Radius
- Repeatability ±5 arcsec / ±.0008" at 30" Radius

Optional Accessories

- 7300C Reducer (Ratios from 15:1 to 60:1)
- 1.5 hp DC motor
- Varipak DC Motor Control (up to 30 cpm)
- 7350C Heavy Duty Reducer (Ratios from 10:1 to 60:1)
- Stationary Center Post
- Dual Cam and Limit Switch
- Left Hand Cam
- Relief in Dwell for shot-pin applications

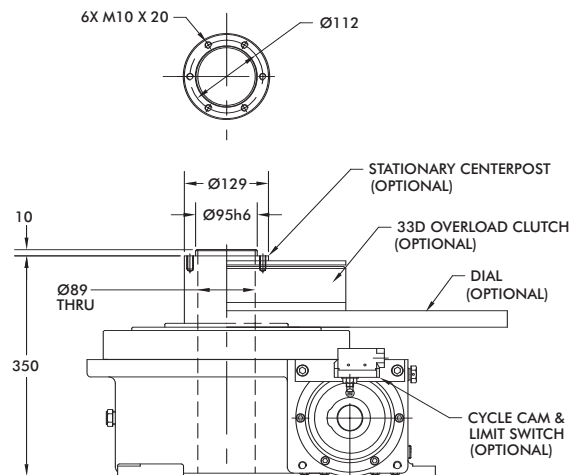

Unless otherwise noted, all dimensions are in mm.

Dimensions and technical information are subject to change without notice.

1305RDM Standard Dimensions

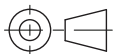
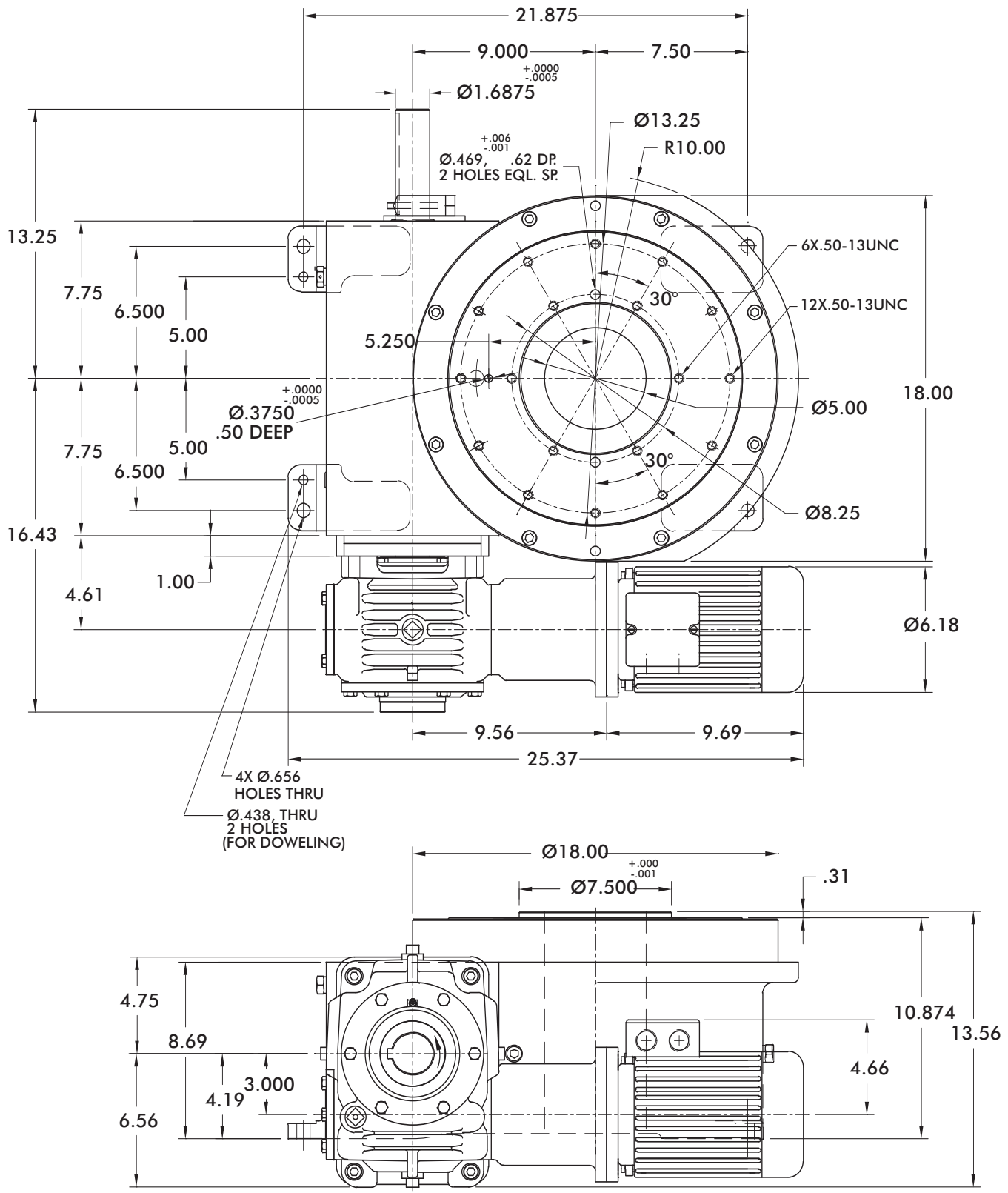

Unless otherwise noted, all dimensions are in inches.

Dimensions and technical information are subject to change without notice.



1305RDM Product Overview and Technical Specifications

Stops	Maximum Inertia x 1000 [lb-in ²] for standard package						
	Motion Time [seconds]						
	0.458	0.611	0.764	0.917	1.222	1.528	1.833
2	0	4	13	26	48	73	102
3	2	11	26	50	88	133	184
4	10	32	71	130	227	340	467
6	25	72	154	281	485	724	994
8	47	131	277	502	864	1,290	1,770
12	111	300	629	1,134	1,950	2,908	3,988
16	200	537	1,121	2,019	3,470	5,173	7,092
	Reducer Ratio						
	15	20	25	30	40	50	60

Other Motions (stops and index periods) available. Contact your DE-STA-CO sales representative for more information.

Features

- 7300C Reducer (Ratios from 15:1 to 60:1)
- Double Extended Camshaft (Input Shaft)
- Center Thru Hole (5.00 in. Diameter)
- 2 hp AC Drive Package with Inverter Duty Motor and Inverter Drive (up to 60 cpm)
- Cycle Cam and Limit Switch Mounted to Camshaft
- Right Hand Cam

Output Load Capacity (loads carried during index):

- Radial 4,650 lbs
- Thrust/Axial 11,650 lbs
- Moment 40,528 in-lb

Typical Application

- Dial Diameter: 20 in. to 72 in.
- Accuracy ±38 arcsec / ±.007" at 36" Radius
- Repeatability ±10 arcsec / ±.002" at 36" Radius

Optional Accessories

- 2 hp DC Motor
- Varipak DC Motor Control (up to 30 cpm)
- 7350C Heavy Duty Reducer (Ratios from 10:1 to 60:1)
- Output Overload Clutch model 32D
 - Available Settings (in-lbs): 8500, 13000, 20000, 31000
- Stationary Center Post
- Dual Cam and Limit Switch
- Base Riser Blocks
- Electric Clutch-Brake
- Left Hand Cam
- Relief in Dwell for shot-pin applications

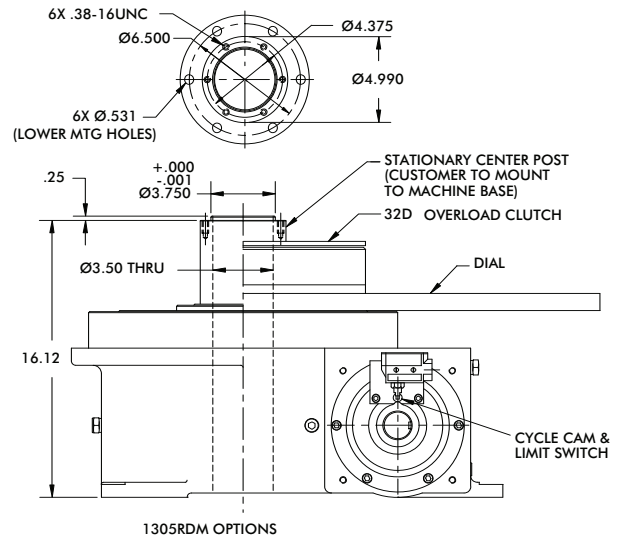

Unless otherwise noted, all dimensions are in inches.

Dimensions and technical information are subject to change without notice.

1800RDM Standard Dimensions

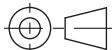
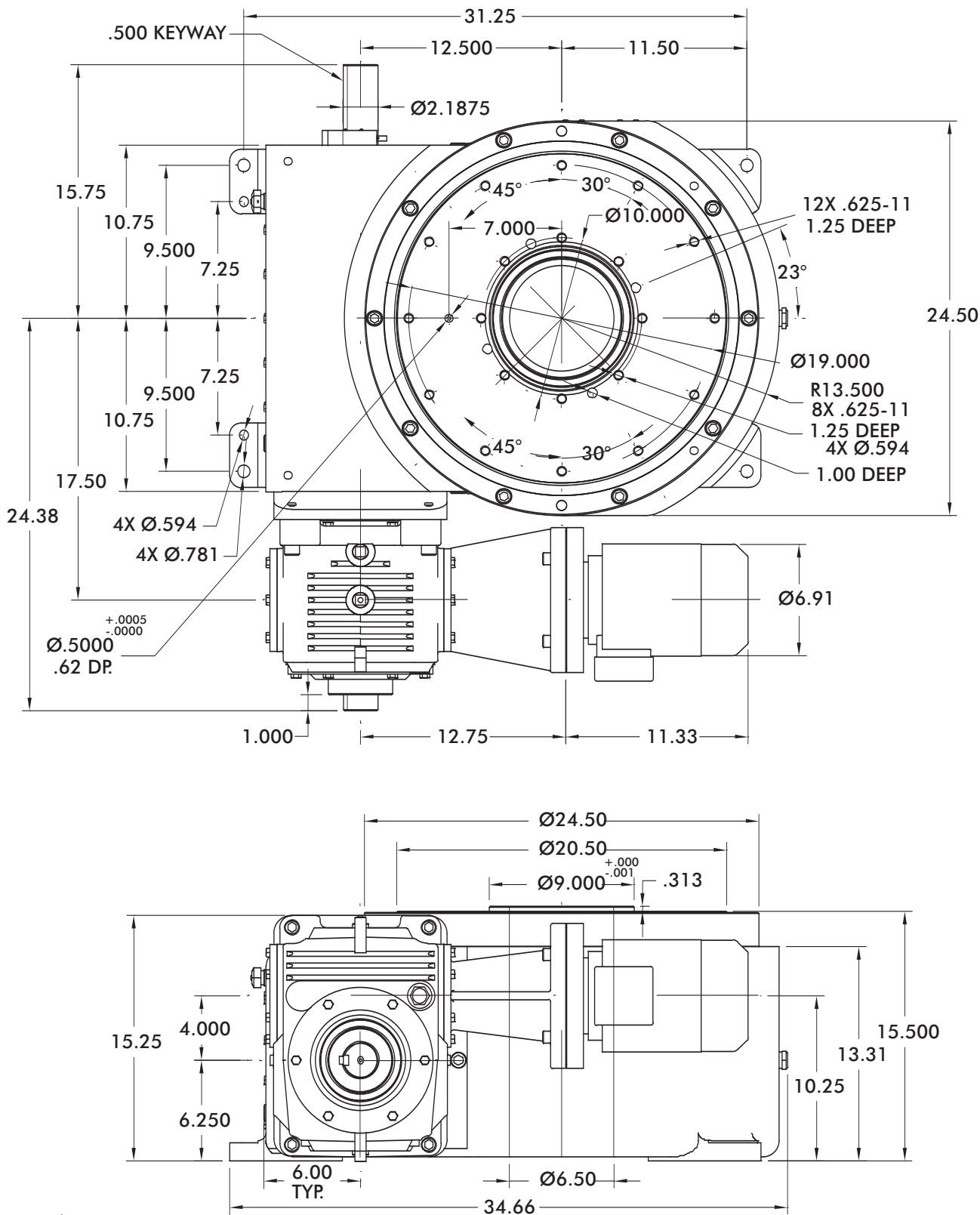

Unless otherwise noted,
all dimensions are in inches.

Dimensions and technical information are subject to change without notice.



1800RDM Product Overview and Technical Specifications

Maximum Inertia x 1000 [lb-in ²] for standard package							
Stops	Motion Time [seconds]						
	0.458	0.611	0.764	0.917	1.222	1.528	1.833
2	0	0	8	27	91	182	256
3	0	11	41	87	246	472	655
4	1	31	85	169	455	862	1,192
6	19	83	197	375	981	1,842	2,542
8	45	158	361	678	1,754	3,286	4,530
12	120	376	832	1,544	3,966	7,412	10,211
16	224	679	1,490	2,756	7,062	13,188	18,163
Reducer Ratio							
	15	20	25	30	40	50	60

Features

- 7400C Reducer (Ratios from 15:1 to 60:1)
- Double Extended Camshaft (Input Shaft)
- Center Thru Hole (6.50 in. Diameter)
- 2 or 3 hp AC Drive Package with Inverter Duty Motor and Inverter Drive (up to 60 cpm)
- Cycle Cam and Limit Switch Mounted to Camshaft
- Right Hand Cam

Output Load Capacity (loads carried during index):

- Radial 5,850 lbs
- Thrust/Axial 14,650 lbs
- Moment 68,119 in-lb

Typical Application

- Dial Diameter: 26 in. to 96 in.
- Accuracy ±27 arcsec / ±.006" at 48" Radius
- Repeatability ±7 arcsec / ±.0016" at 48" Radius

Optional Accessories

- 2 hp DC Motor with Varipak DC Motor Control (up to 30 cpm)
- 3 hp DC Motor
- 7500C Heavy Duty Reducer (Ratios from 10:1 to 60:1)
- Output Overload Clutch model 61D – Available Settings (in-lbs): 23000, 36000, 44000, 50000, 60000
- Stationary Center Post
- Dual Cam and Limit Switch
- Base Riser Blocks
- Electric Clutch-Brake
- Left Hand Cam
- Relief in Dwell for shot-pin applications

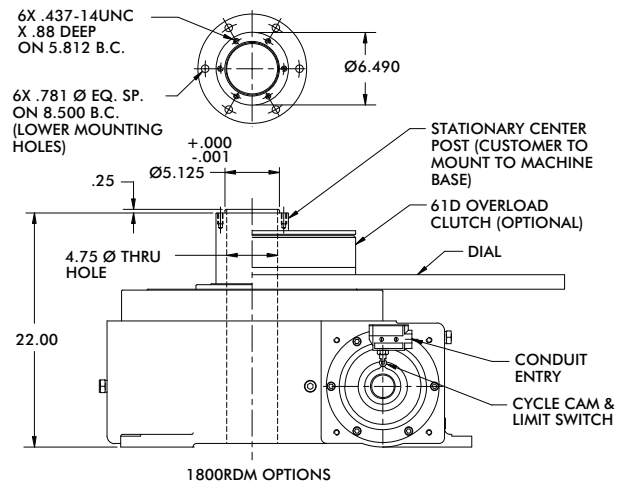

Unless otherwise noted, all dimensions are in inches.

Dimensions and technical information are subject to change without notice.



Notes

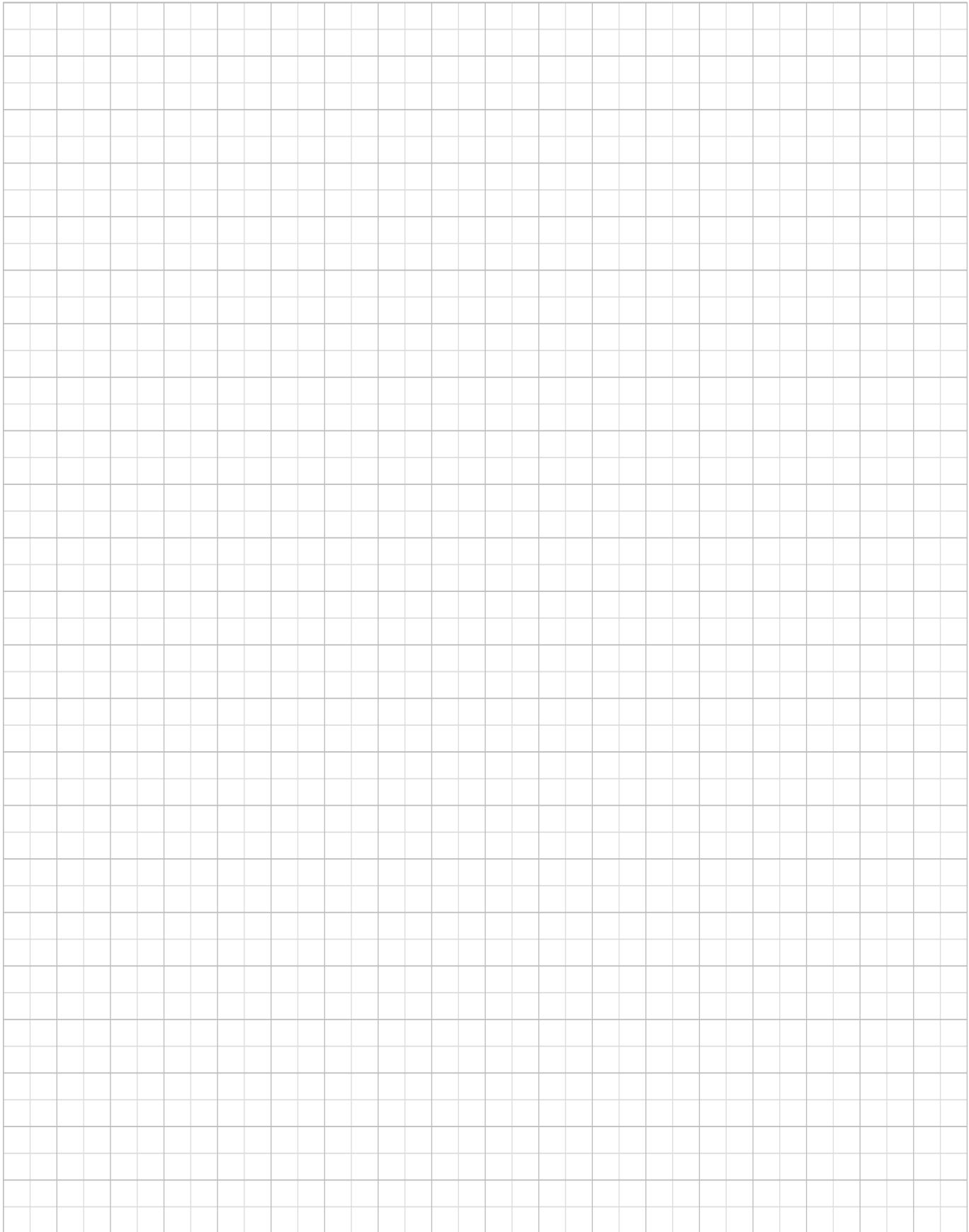

Dimensions and technical information are subject to change without notice.

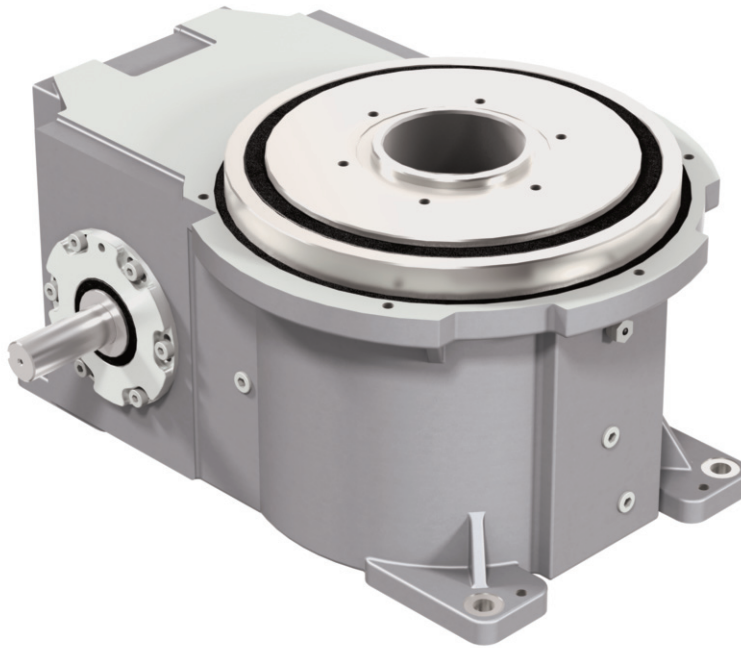

Features:

CAMCO Roller Dial Index Drives have a robust, flexible design with superior load capabilities. Other features include:

- Short camshaft motion periods, due to oversized roller gear cam design, are well suited for continuous running applications or for special motion requirements such as oscillating motions
- Universal mounting including a horizontal mounting ideal for trunion applications
- Option Center Thru-Hole facilitates passage of electrical wiring, pneumatic lines or mechanical linkages
- Optional Stationary Center Post with thru-hole provides mounting for upper tool plate

Table of Contents

How to Order	56
425RD	58
800RD	60
1301RD	62
1801RD	64

RD Series How to Order

Base Model Description
425RD w/ R180 reducer & 1/3 hp AC motor (220/440V)
800RD w/ 7300C reducer & 2 hp AC motor (220/440V)
1301RD w/ 7350C reducer & 2 hp AC motor (220/440V)
1801RD w/ 7500C reducer & 3 hp AC motor (220/440V)

Control (only available with these models)

- 1** 1 hp 120V 425RD only
- 2** 1 hp 240V 425RD only
- 3** 1 hp 440V 425RD only
- 4** 2 hp 240V 800RD & 1301RD only
- 5** 2 hp 440V 800RD & 1301RD only
- 6** 3 hp 240V 1801RDM only
- 7** 3 hp 440V 1801RDM only



Motion	Stops	Index Period
A	2	330
B	3	330
C	4	330
D	6	330
E	8	330
F	12	330
G	16	330*

*1301RD & 1801RD

Index Mounting
(See Figure 1)

- 1**
- 2**
- 3**
- 4**
- 5**
- 6**

Reducer Ratio

- A** 15
- B** 20
- C** 25
- D** 30
- E** 40
- F** 50
- G** 60

Reducer Mounting
(See Figure 4)

- A** **J**
- B** **K**
- C** **L**
- D** **M**
- E** **N**
- F** **P**
- G** **R**
- H** **S**

Signal Switch **Signal Switch Side**
(See Figure 2)

- M** Mechanical **R** Reducer
 - P** Proximity **S** Shaft
- Example: MR, MS, PR or PS**

Note about signal switch options:
 a) Mechanical is a single switch with cam.
 b) Proximity option is a mounting bracket for 8 or 12 mm proximity switch. A proximity switch will not be supplied. Cam supplied as target.

Other Motions (stops and index periods) available. Contact your DE-STA-CO sales representative for more information.

Input Shaft Configuration/Rotation (Figure 1)

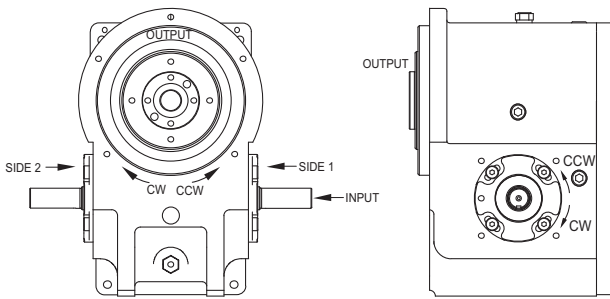

Relative Rotation for Right Hand Cam:



CW Input Side 1 CCW Output
 CCW Input Side 2 CW Output

NOTE: Input can be driven in either direction

Signal Switch Mounting Position (Figure 2)

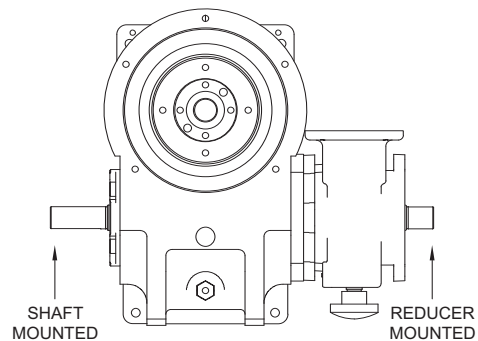





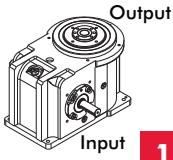
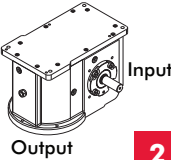
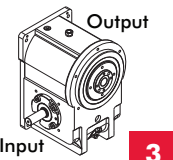
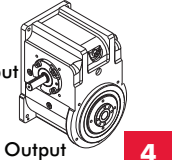
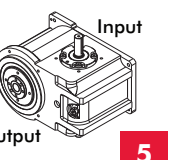
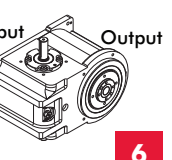

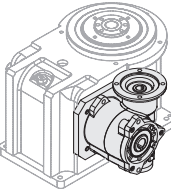
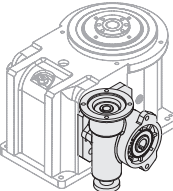
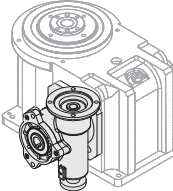
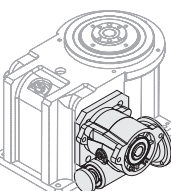

Dimensions and technical information are subject to change without notice.

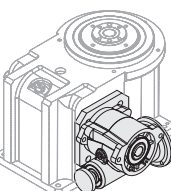
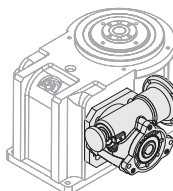
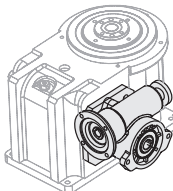
Input/Output Orientation (Figure 3)

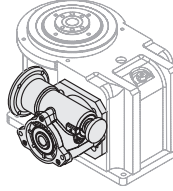
OVOI (output vertical, over input)	OVUI (output vertical, under input)	OHOI (output horizontal, over input)	OHUI (output horizontal, under input)	H-S1-UP (output horizontal, side 1 up)	H-S2-UP (output horizontal, side 2 up)
 1	 2	 3	 4	 5	 6

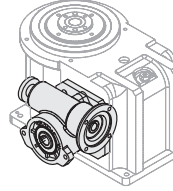
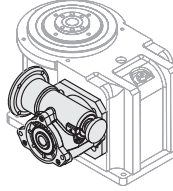
Gear Reducer Mounting Positions (Figure 4)

		Mounting "A"		Mounting "B"	
		RD Worm	LD Worm	RD Worm	LD Worm
SIDE 1	 A	 B	 C	 D	
	 B	 C	 D	 E	
SIDE 2	 E	 F	 G	 H	
	 F	 G	 H	 I	
		Mounting "C"		Mounting "D"	
		RD Worm	LD Worm	RD Worm	LD Worm
SIDE 1	 I	 J	 K	 L	 M
	 J	 K	 L	 M	N
SIDE 2	 N	 O	 P	 Q	 R
	 O	 P	 Q	 R	S

Dimensions and technical information are subject to change without notice.

425RD Standard Dimensions

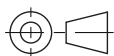
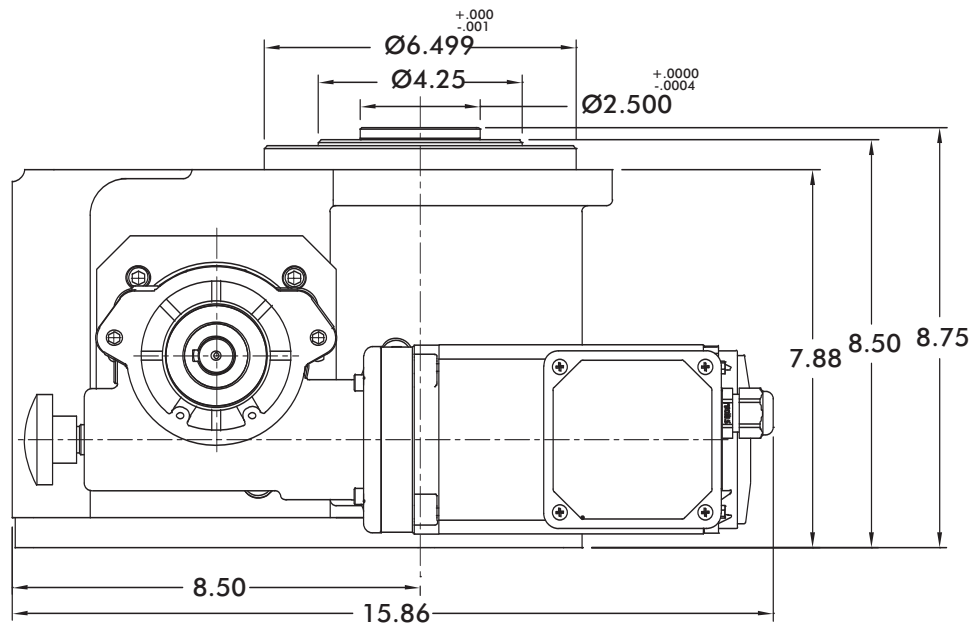
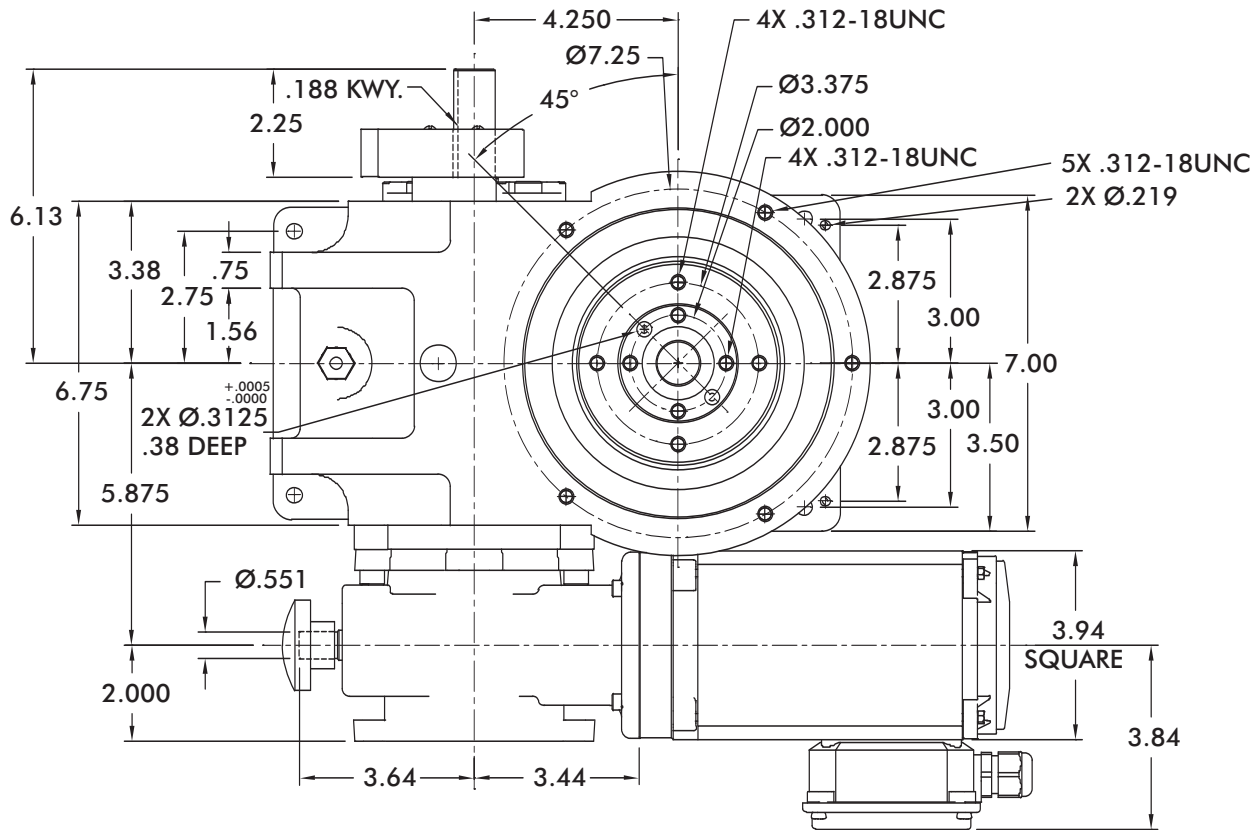

Unless otherwise noted, all dimensions are in inches.

Dimensions and technical information are subject to change without notice.



425RD Product Overview, Technical Information, Optional Accessories

Maximum Inertia x 1000 [lb-in ²] for standard package							
Stops	Motion Time [seconds]						
	0.458	0.611	0.764	0.917	1.222	1.528	1.833
2	0	1	2	4	11	16	22
3	1	2	6	11	25	37	50
4	1	5	10	19	44	66	90
6	4	11	24	44	100	150	156
8	7	20	43	79	156	156	156
12	16	45	89	136	147	147	147
Reducer Ratio							
	15	20	25	30	40	50	60

Features

- R180 Reducer (ratios from 15:1 to 60:1)
 - Double Extended Worm Shaft (Input)
 - Worm Shaft Handwheel
- Double Extended Camshaft (Input Shaft)
- 1/3 hp AC Drive Package with Inverter Duty Motor and IM-pAC AC Drive (up to 60 cpm)
- R225 Reducer with 1 hp AC or DC Motor (ratios of 5:1 to 60:1)
- Cycle Cam and Limit Switch Mounted to Camshaft
- Right Hand Cam

Output Load Capacity (loads carried during index):

Radial 2,700 lbs
 Thrust/Axial 1,600 lbs
 Moment 5,800 in-lbs

Accuracy ±47 arcsec / ±.0027" at 12" Radius

Repeatability ±12 arcsec / ±.0007" at 12" Radius

Optional Accessories

- 1/3 hp DC Motor
- Varipak DC Motor Control (up to 30 cpm)
- 2.8D Output Overload Clutch
 - Available Settings (in-lbs): 400, 480, 700, 850, 1100, 1300, 1800, 2200, 3100
- Center Thru Hole (0.81 in. Diameter)
- Stationary Center Post
- Dual Cam and Limit Switch
- Left Hand Cam
- Relief in Dwell for shot-pin applications
- Universal Mounting Capability
- Custom Dial Plate

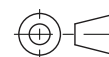
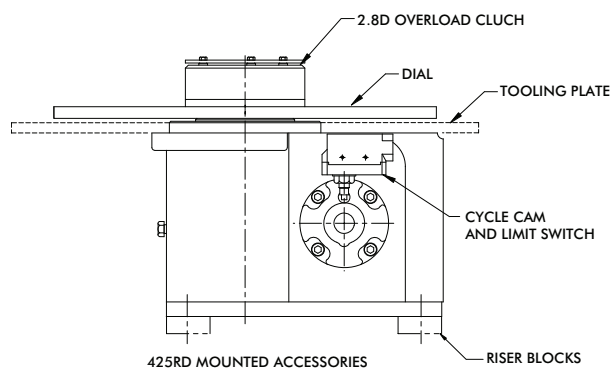

Unless otherwise noted, all dimensions are in inches.

Dimensions and technical information are subject to change without notice.

800RD Standard Dimensions

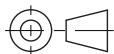
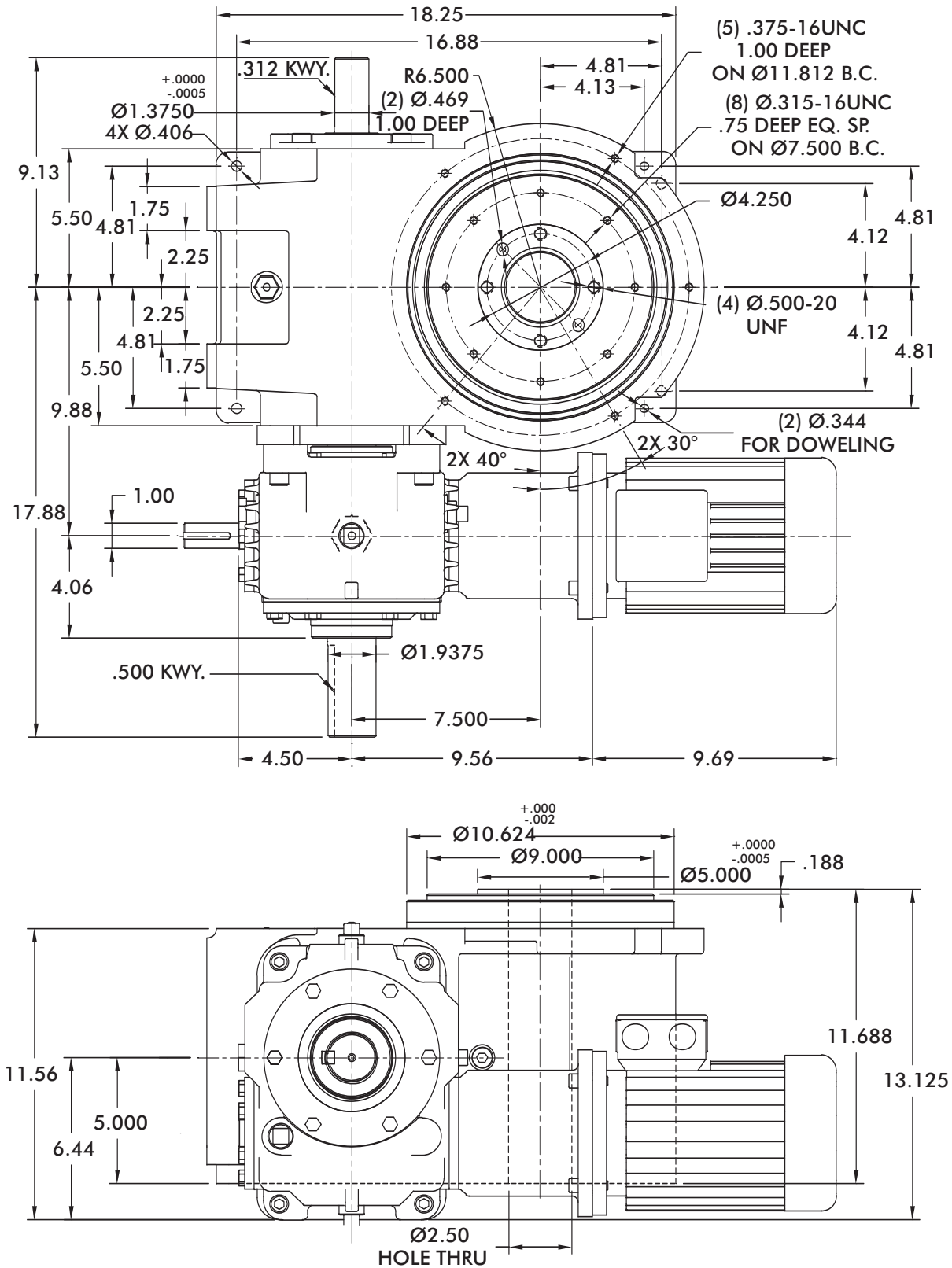

Unless otherwise noted, all dimensions are in inches.

Dimensions and technical information are subject to change without notice.



800RD Product Overview, Technical Information, Optional Accessories

Stops	Maximum Inertia x 1000 [lb-in ²] for standard package						
	Motion Time [seconds]						
	0.458	0.611	0.764	0.917	1.222	1.528	1.833
2	2	8	17	32	55	83	114
3	7	19	40	72	125	187	258
4	13	35	72	130	223	334	459
6	30	79	164	293	504	753	1,034
8	54	142	292	521	897	1,232	1,232
12	123	312	522	794	1,156	1,156	1,156
	Reducer Ratio						
	15	20	25	30	40	50	60

Features

- 7300C Reducer (Ratios from 15:1 to 60:1)
 - Double Extended Worm Shaft (Input)
 - Motor Adapter and Coupling
- Double Extended Camshaft (Input Shaft)
- 1 hp AC Drive Package with Inverter Duty Motor and IM-pAC AC Drive (up to 60 cpm)
- Cycle Cam and Limit Switch Mounted to Camshaft
- Right Hand Cam

Output Load Capacity (loads carried during index):

- Radial 4,977 lbs
- Thrust/Axial 3,561 lbs
- Moment 22,398 in-lbs

Accuracy ±30 arcsec / ±.004" at 24" Radius

Repeatability ±8 arcsec / ±.0009" at 24" Radius

Optional Accessories

- 7350C Reducer (ratios from 5:1 to 60:1) with 1 hp AC or DC Motor
- 1 hp DC Motor
- Varipak DC Motor Control (up to 30 cpm)
- Output Overload Clutch model 7.8D
 - Available Settings (in-lbs): 1400, 1700, 2600, 3200, 4200, 5000, 7200, 10,000
- Output Overload Clutch model 18D
 - Available Settings (in-lbs): 5000, 7000, 7800, 10,000, 12,000, 16,000, 19,000, 21,000, 27,000, 42,000, 45,000
- Center Thru Hole (2.50 in. Diameter)
- Stationary Center Post
- Dual Cam and Limit Switch
- Left Hand Cam
- Relief in Dwell for shot-pin applications
- Universal Mounting Capability
- Custom Dial Plate

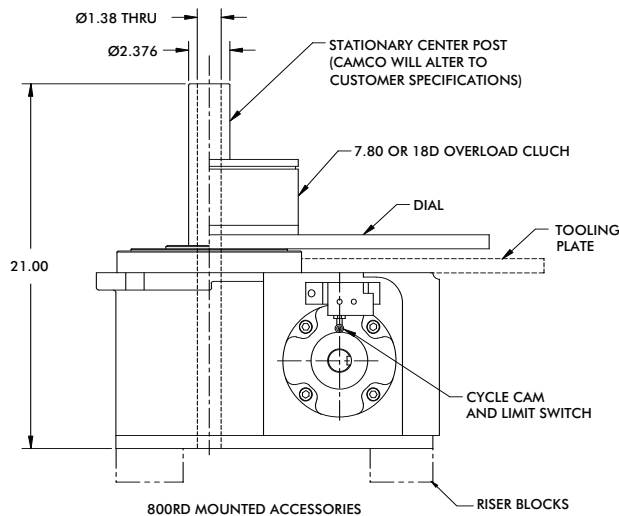

Unless otherwise noted, all dimensions are in inches.

Dimensions and technical information are subject to change without notice.

1301RD Standard Dimensions

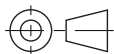
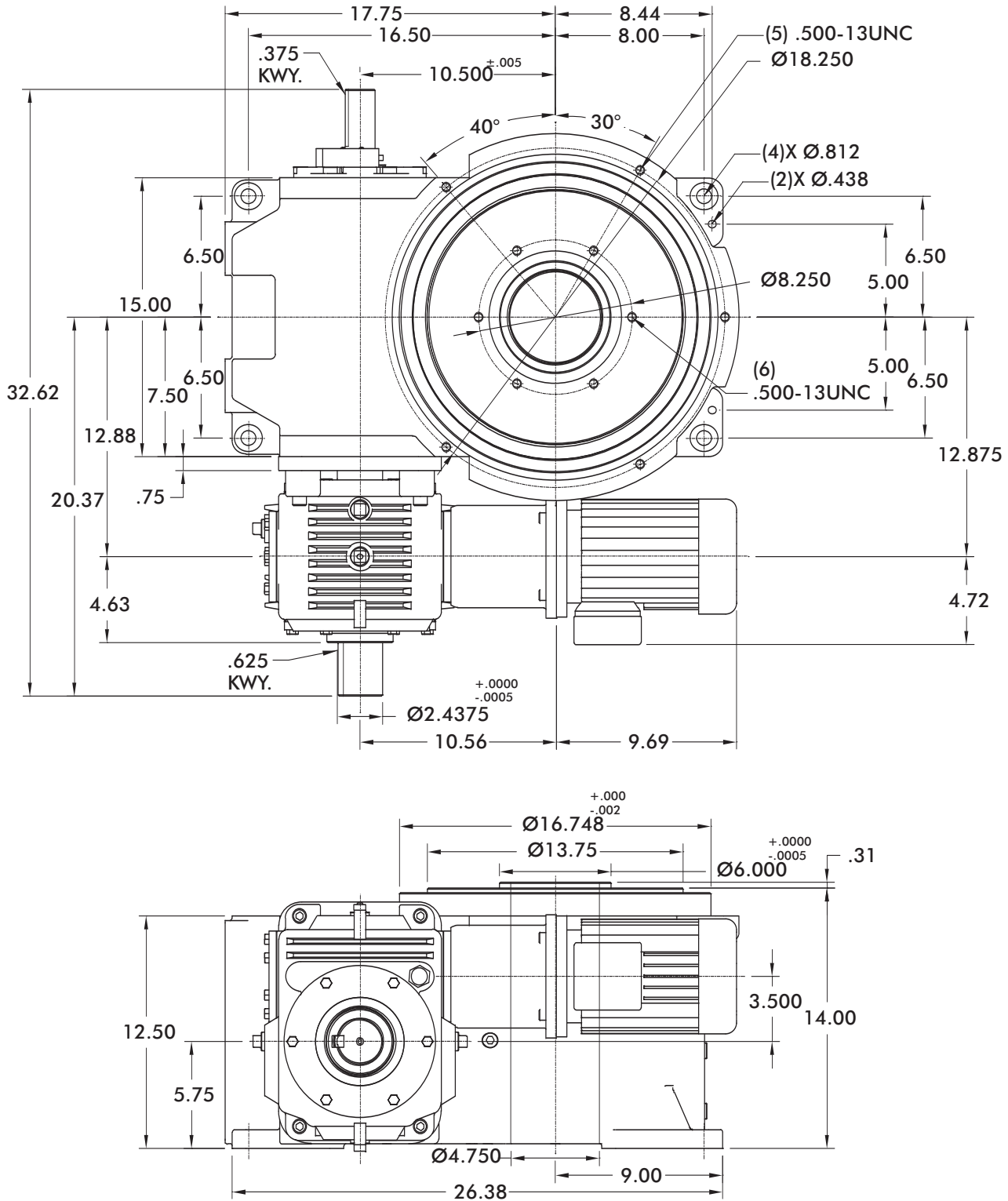

Unless otherwise noted, all dimensions are in inches.

Dimensions and technical information are subject to change without notice.



1301RD Product Overview, Technical Information, Optional Accessories

Maximum Inertia x 1000 [lb-in ²] for standard package							
Stops	Motion Time [seconds]						
	0.458	0.611	0.764	0.917	1.222	1.528	1.833
2	0	5	15	29	51	78	108
3	4	16	37	68	119	179	246
4	10	31	67	123	214	321	440
6	26	73	155	281	485	725	995
8	48	132	278	503	865	1,291	1,771
12	111	301	630	1,135	1,951	2,909	3,989
16	201	538	1,122	2,020	3,471	5,174	7,093
Reducer Ratio							
	15	20	25	30	40	50	60

Features

- 7350C Reducer (Ratios from 15:1 to 60:1)
 - Double Extended Worm Shaft (Input)
 - Motor Adapter and Coupling
- Double Extended Camshaft (Input Shaft)
- 2 hp AC Drive Package with Inverter Duty Motor and Inverter Drive (up to 60 cpm)
- Cycle Cam and Limit Switch Mounted to Camshaft
- Right Hand Cam

Output Load Capacity (loads carried during index):

- Radial 15,800 lbs
- Thrust/Axial 10,800 lbs
- Moment 109,000 in-lbs

Accuracy

±39 arcsec / ±.0068" at 36" Radius

Repeatability

±10 arcsec / ±.0017" at 36" Radius

Optional Accessories

- 7400C Reducer (Ratios from 5:1 to 60:1) with Motor Adapter and Coupling
- 2 hp DC Motor
- Varipak DC Motor Control (up to 30 cpm)
- Output Overload Clutch model 31D
 - Available Settings (in-lbs): 8500, 13,000, 20,000, 31,000
- Center Thru Hole (4.75 in. Diameter)
- Stationary Center Post
- Dual Cam and Limit Switch
- Left Hand Cam
- Relief in Dwell for shot-pin applications
- Universal Mounting Capability
- Custom Dial Plate

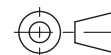
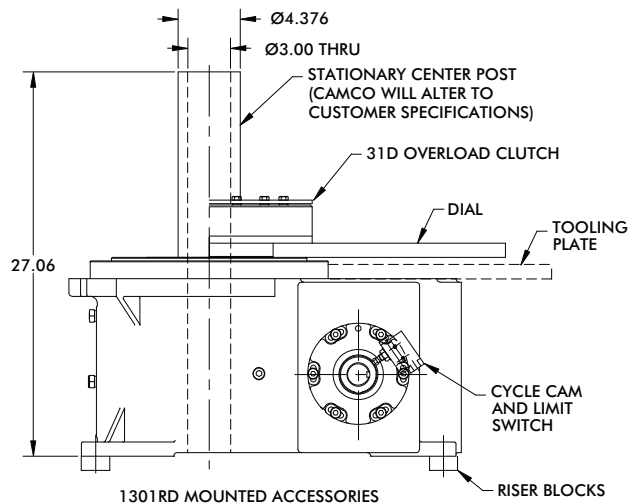

Unless otherwise noted, all dimensions are in inches.

Dimensions and technical information are subject to change without notice.

1801RD Standard Dimensions

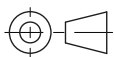
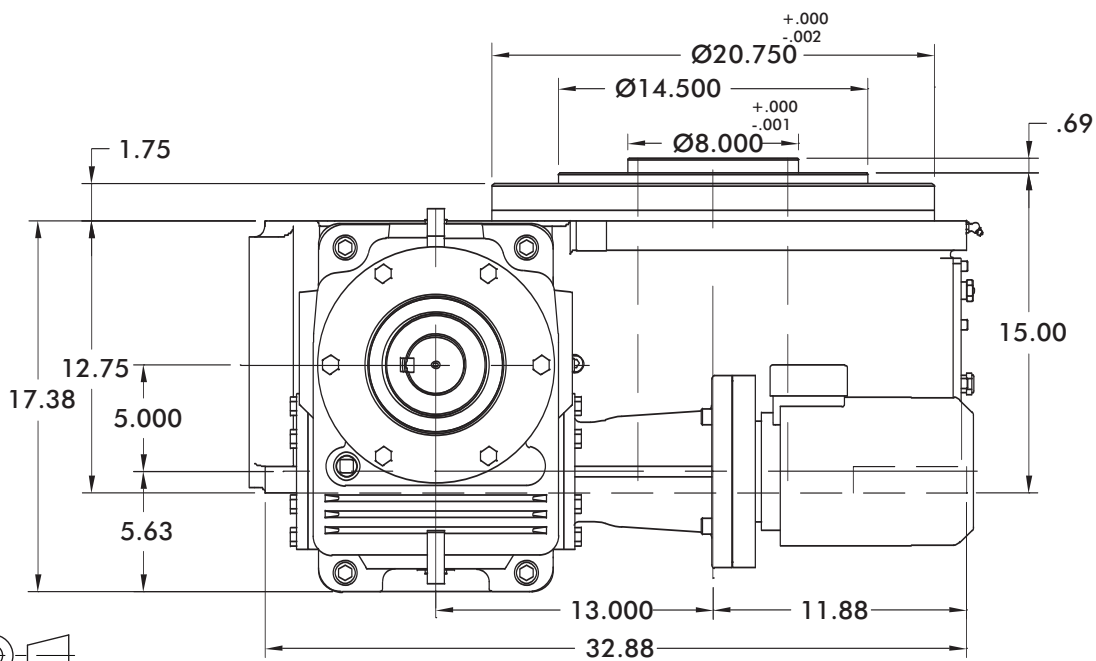
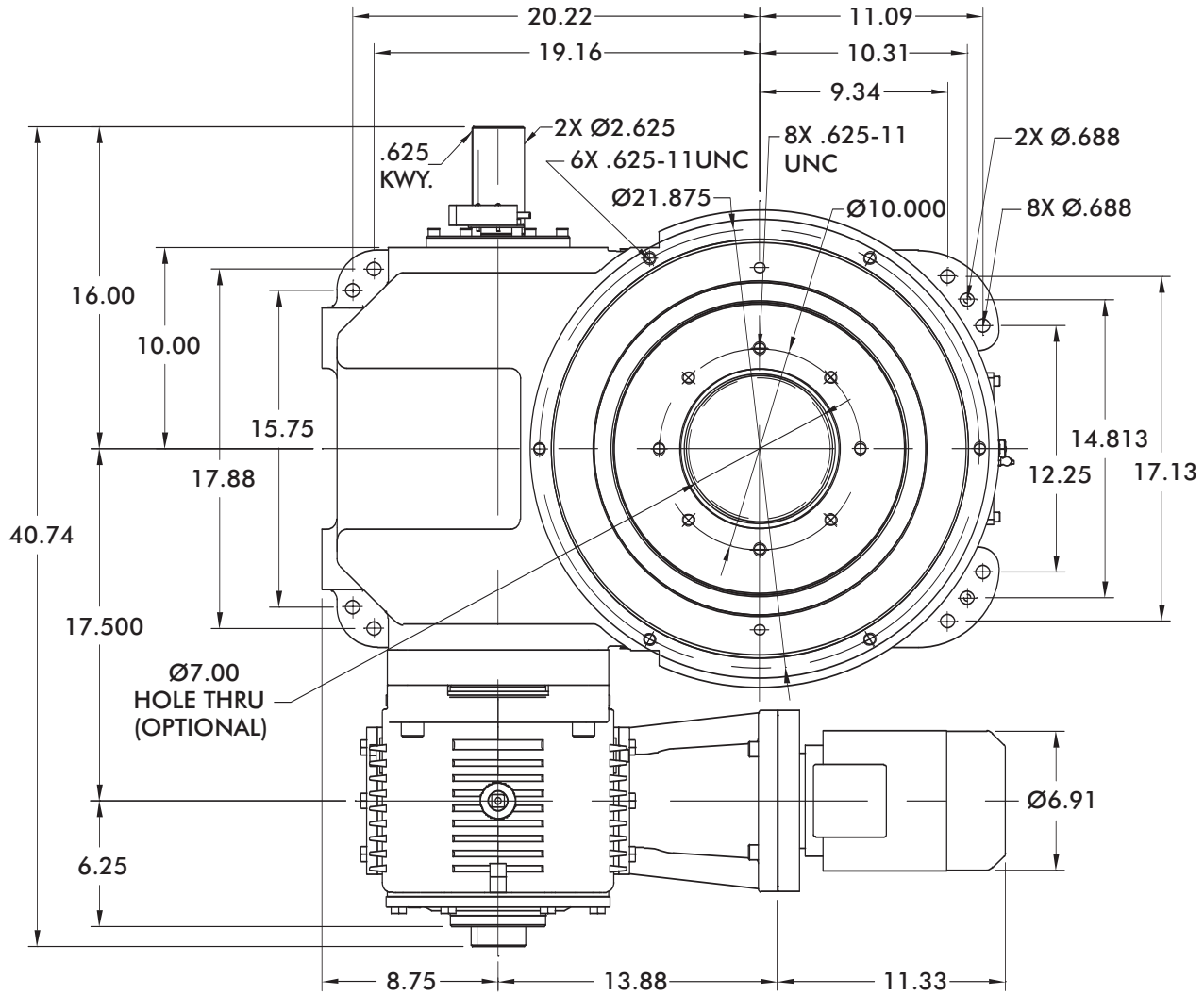

Unless otherwise noted, all dimensions are in inches.

Dimensions and technical information are subject to change without notice.



1801RD Product Overview, Technical Information, Optional Accessories

Maximum Inertia x 1000 [lb-in ²] for standard package							
Stops	Motion Time [seconds]						
	0.458	0.611	0.764	0.917	1.222	1.528	1.833
2	0	5	18	39	109	229	412
3	2	17	44	86	230	476	850
4	9	39	92	175	458	939	1,672
6	27	91	205	383	989	2,021	3,593
8	54	168	370	687	1,763	3,598	6,393
12	127	383	839	1,552	3,973	8,102	14,391
16	232	687	1,498	2,765	7,070	1,441	19,455
Reducer Ratio							
	15	20	25	30	40	50	60

Features

- 7500C Reducer (Ratios from 15:1 to 60:1)
 - Double Extended Worm Shaft (Input)
 - Motor Adapter and Coupling
- Double Extended Camshaft (Input Shaft)
- 3 hp AC Drive Package with Inverter Duty Motor and Inverter Drive (up to 60 cpm)
- Cycle Cam and Limit Switch Mounted to Camshaft
- Right Hand Cam

Output Load Capacity (loads carried during index):

- Radial 14,800 lbs
- Thrust/Axial 12,600 lbs
- Moment 107,000 in-lbs

Accuracy

±27 arcsec / ±.0063" at 48" Radius

Repeatability

±7 arcsec / ±.0016" at 48" Radius

Optional Accessories

- 7600C or 7700C Reducer (Ratios from 5:1 to 60:1) with Motor Adapter and Coupling
- 3 hp DC Motor
- Output Overload Clutch model 62D
 - Available Settings (in-lbs): 23,000, 36,000, 44,000, 50,000, 60,000
- Center Thru Hole (7.00 in. Diameter)
- Stationary Center Post
- Dual Cam and Limit Switch
- Left Hand Cam
- Relief in Dwell for shot-pin applications
- Custom Dial Plate

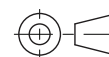
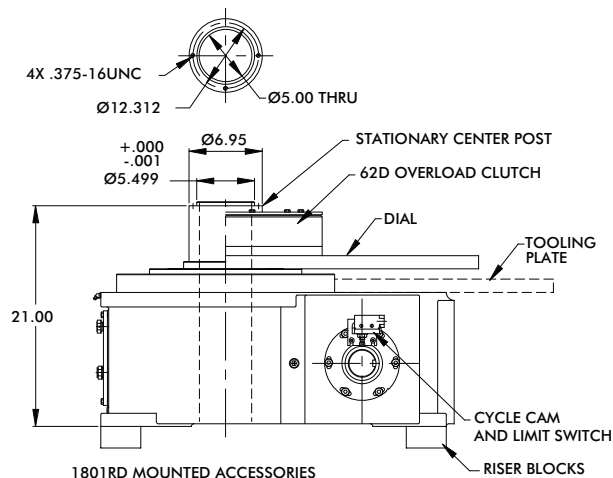

Unless otherwise noted, all dimensions are in inches.

Dimensions and technical information are subject to change without notice.

Notes

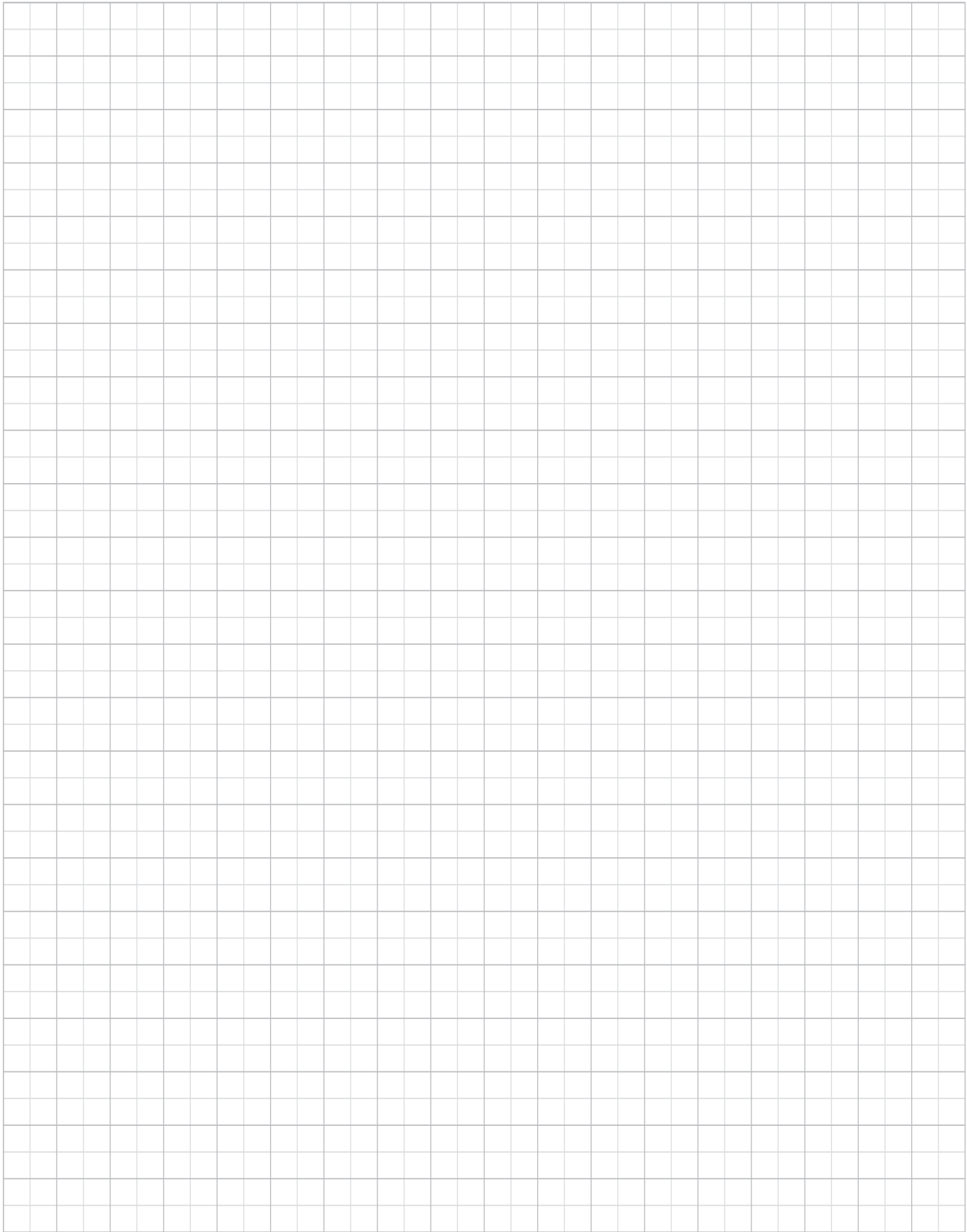

Dimensions and technical information are subject to change without notice.

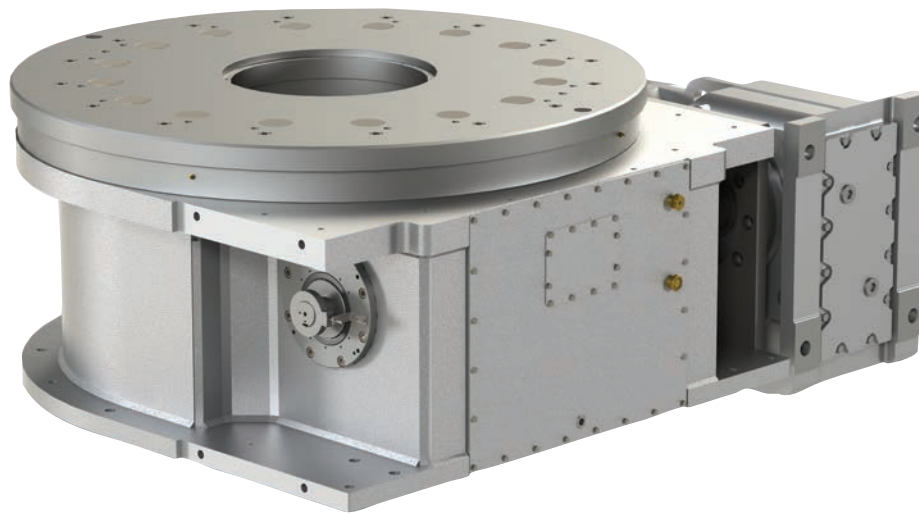

Features:

The **CAMCO E-Series Heavy Duty Index Drive** is ideal for heavy-duty rotary dial applications with features including:

- Large output mounting surface supported by a 4-point contact bearing providing superior thrust and moment capacity
- Large center thru-hole to accommodate stationary center post, electrical wiring and air or hydraulic lines
- Complete motorized drive package with reducer and AC inverter drive to suit most applications
- Precision cam with preloaded cam followers for maximum accuracy
- Durable welded steel housing
- Preloaded “center rib” design for smooth acceleration and deceleration with precision positioning

Table of Contents

How to Order	68
750E	70
950E	72
1150E	74
1550E	76

Dimensions and technical information are subject to change without notice.



E Series How to Order

Base Model Description

- 750E** w/ KH87 reducer & 12.5 hp AC motor (220/440V)
- 950E** w/ KH87 reducer & 15 hp AC motor (220/440V)
- 1150E** w/ KH107 reducer & 25 hp AC motor (220/440V)
- 1550E** w/ KH127 reducer & 30 hp AC motor (220/440V)

Control (only available with these models)

- 1** 15 hp 240V 750E & 950E only
- 2** 15 hp 440V 750E & 950E only
- 3** 25 hp 240V 1150E only
- 4** 25 hp 440V 1150E only
- 5** 30 hp 240V 1550E only
- 6** 30 hp 440V 1550E only



Motion	Stops	Index Period
A	2	330
B	3	330
C	4	330
D	6	330
E	8	330
F	12	330
G	16	330

Index Mounting
(See Figure 1)

- 1**
- 2**
- 3**
- 4**
- 5**
- 6**

Reducer Ratio

	750E	950E	1150E	1550E
A	14.50	29.00	40.19	
B	19.95	42.33	54.07	
C	24.92	49.90	70.95	
D	31.39	52.17	81.98	
E	44.02	66.52	89.89	
F	49.16	73.30	110.18	
G	63.00	82.61	122.98	

Reducer Mounting
(See Figure 3)

- A**

Signal Switch

- M** Mechanical
- P** Proximity

Example: MS or PS

Note about signal switch options:

- a) Mechanical is a single switch with cam.
- b) Proximity option is a mounting bracket for 8 or 12 mm proximity switch. A proximity switch will not be supplied. Cam supplied as target.

Signal Switch Side
(See Figure 2)

- S** Shaft

Other Motions (stops and index periods) available. Contact your DE-STA-CO sales representative for more information.

Dimensions and technical information are subject to change without notice.

Input Shaft Configuration/Rotations (Figure 1)

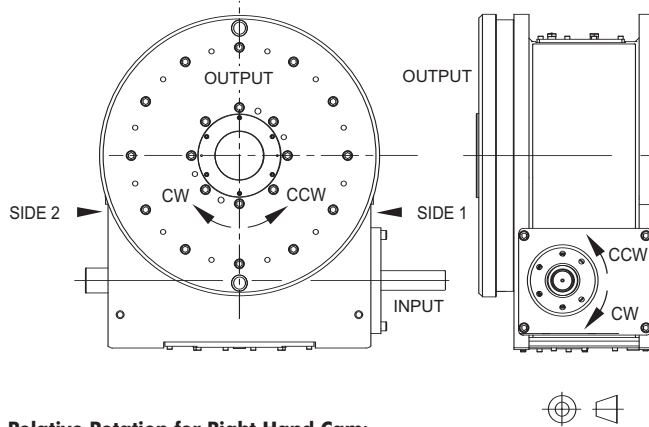

Relative Rotation for Right Hand Cam:

CW Input Side 1 CCW Output

CCW Input Side 2 CW Output

NOTE: Input can be driven in either direction

Signal Switch Mounting Position (Figure 2)

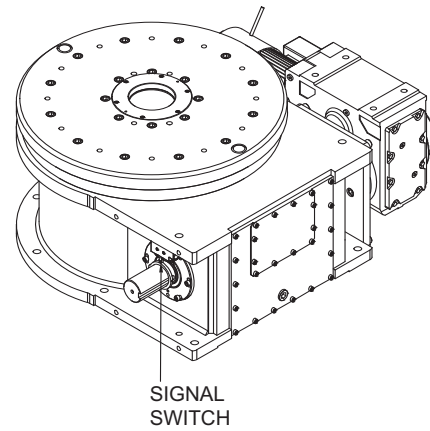

Gear Reducer Mounting Position (Figure 3)

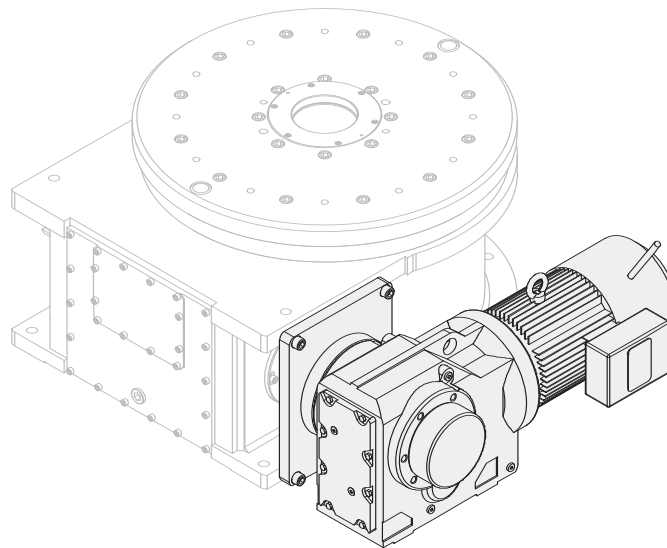

Dimensions and technical information are subject to change without notice.

750E Standard Dimensions

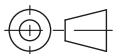
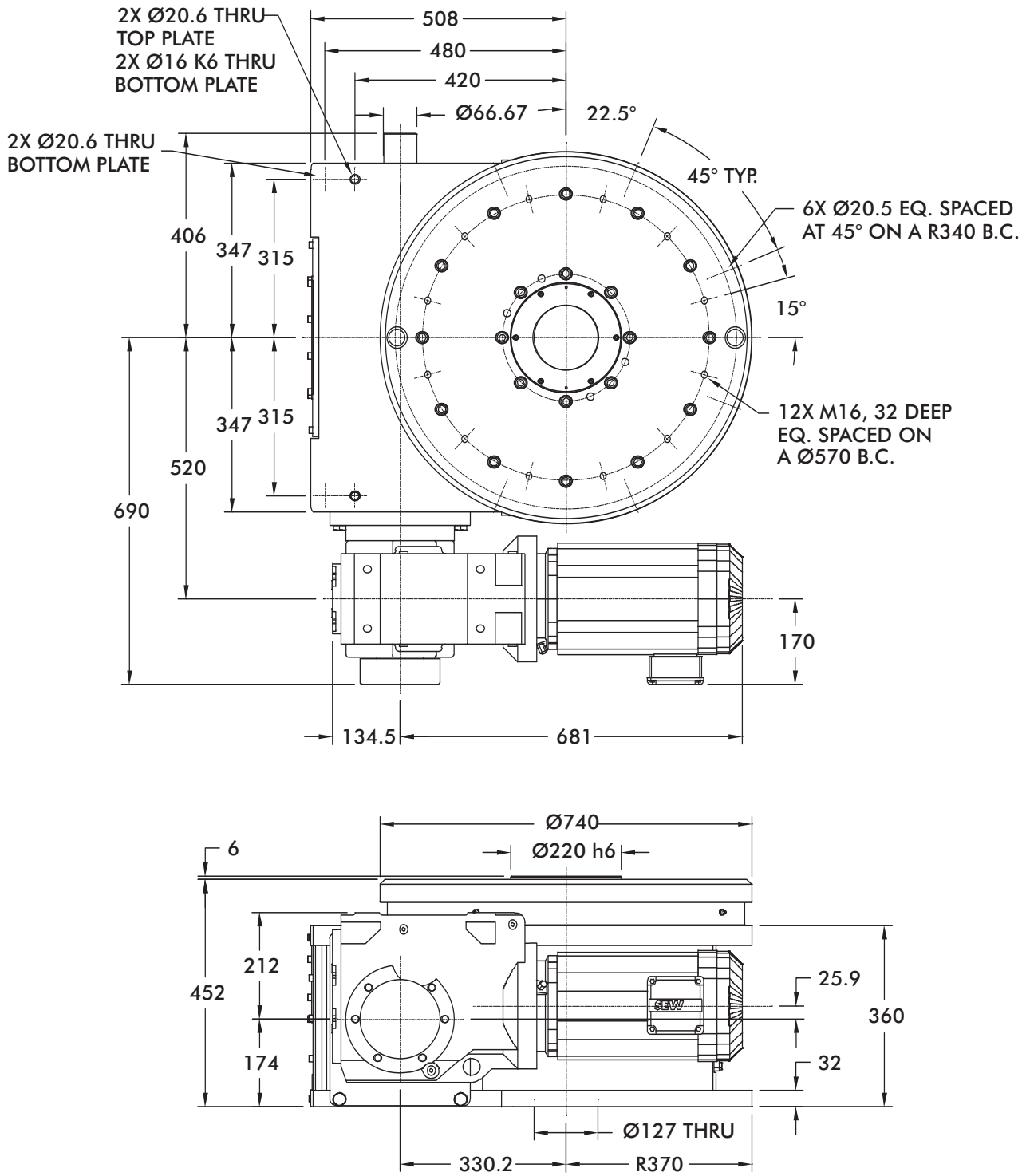

Unless otherwise noted, all dimensions are in mm.

Dimensions and technical information are subject to change without notice.



750E Product Overview, Technical Information, Optional Accessories

Maximum Inertia x 1,000 [lb-in ²] for standard package							
Stops	Motion Time [seconds]						
	0.44	0.59	0.76	0.96	1.35	1.50	1.93
2	0	27	105	254	751	987	1,647
3	14	98	257	562	1,577	2,058	3,407
4	67	231	542	1,140	3,128	4,072	6,714
6	191	542	1,209	2,491	6,756	8,781	14,447
8	372	931	1,677	2,841	5,587	6,968	11,444
12	886	2,291	4,840	8,195	16,116	20,100	33,010
16	1,351	2,717	4,837	8,254	16,263	20,283	33,311
Reducer Ratio							
	14.45	19.45	24.92	31.39	44.02	49.16	63.00

Features

- KH87 Gear Reducer with Brake-motor
- Double Extended Camshaft (Input shaft)
- Center Thru Hole (127 mm)
- Cycle Cam and Limit Switch
- Right Hand Cam

Optional Accessories

- Left Hand Cam
- Relief in Dwell for Shot-Pin applications
- Dual Cam & limit Switch
- KH97 Gear Reducer with Brake-motor
- Stationary Center Post
- Visual Disk Dwell Indicator

Output Load Capacity (loads carried during index):

Radial	29,200 lbs
Thrust/Axial	42,000 lbs
Moment	414,500 in-lbs

Typical Application

Dial Diameter:	55 in. to 110 in.
Accuracy	±27 arcsec / ±.002" at 15" Radius
Repeatability	±7 arcsec / ±.0005" at 15" Radius

Dimensions and technical information are subject to change without notice.

950E Standard Dimensions

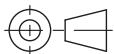
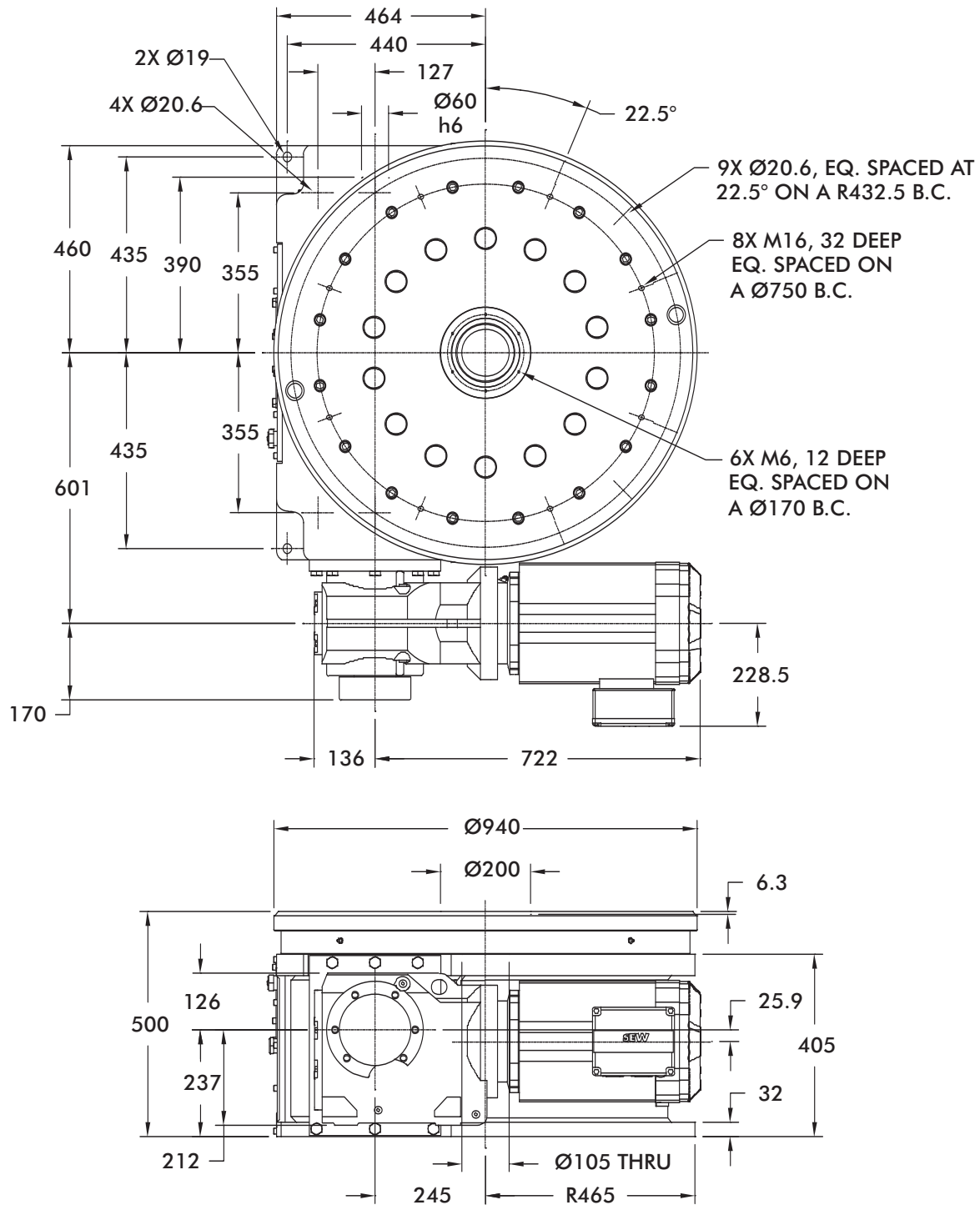

Unless otherwise noted,
all dimensions are in mm.

Dimensions and technical information are subject to change without notice.



950E Product Overview, Technical Information, Optional Accessories

Maximum Inertia x 1,000 [lb-in ²] for standard package							
Stops	Motion Time [seconds]						
	0.44	0.59	0.76	0.96	1.35	1.50	1.93
2	0	0	61	224	619	833	1,433
3	0	59	250	619	1,507	1,989	3,337
4	16	205	564	1,252	2,911	3,810	6,329
6	187	634	1,479	3,102	7,013	9,135	15,073
8	412	1,169	2,603	5,287	11,478	14,315	23,511
12	1,025	2,729	5,956	10,793	23,621	30,484	53,172
16	1,290	2,647	4,753	8,147	17,305	21,582	35,445
Reducer Ratio							
	14.45	19.45	24.92	31.39	44.02	49.16	63.00

Features

- KH87 Gear Reducer with Brake-motor
- Double Extended Camshaft (Input shaft)
- Center Thru Hole (105 mm)
- Cycle Cam and Limit Switch
- Right Hand Cam

Optional Accessories

- Left Hand Cam
- Relief in Dwell for Shot-Pin applications
- Dual Cam & limit Switch
- KH97 Gear Reducer with Brake-motor
- Stationary Center Post
- Visual Disk Dwell Indicator

Output Load Capacity (loads carried during index):

Radial 52,600 lbs
 Thrust/Axial 75,850 lbs
 Moment 977,500 in-lbs

Typical Application

Dial Diameter: 70 in. to 140 in.

Accuracy

±29 arcsec / ±.0023" at 30" Radius

Repeatability

±6 arcsec / ±.0006" at 30" Radius

Dimensions and technical information are subject to change without notice.

1150E Standard Dimensions

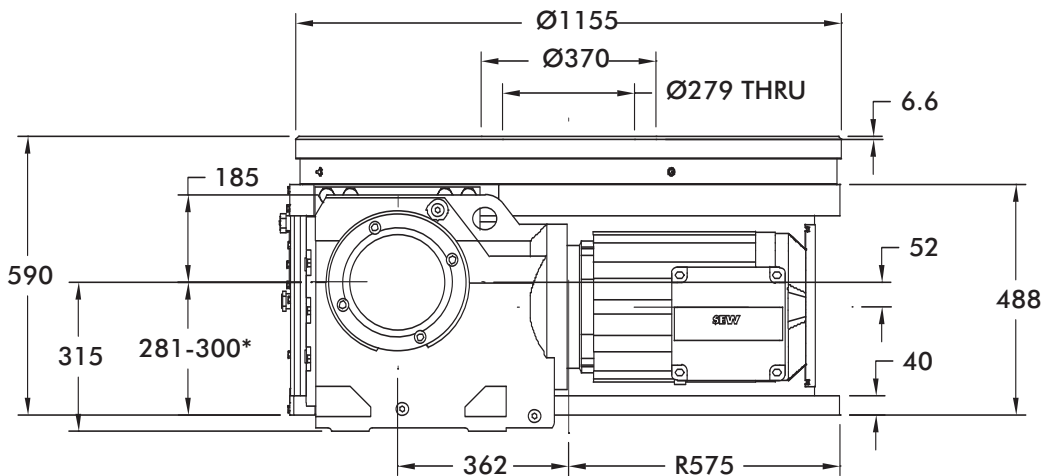
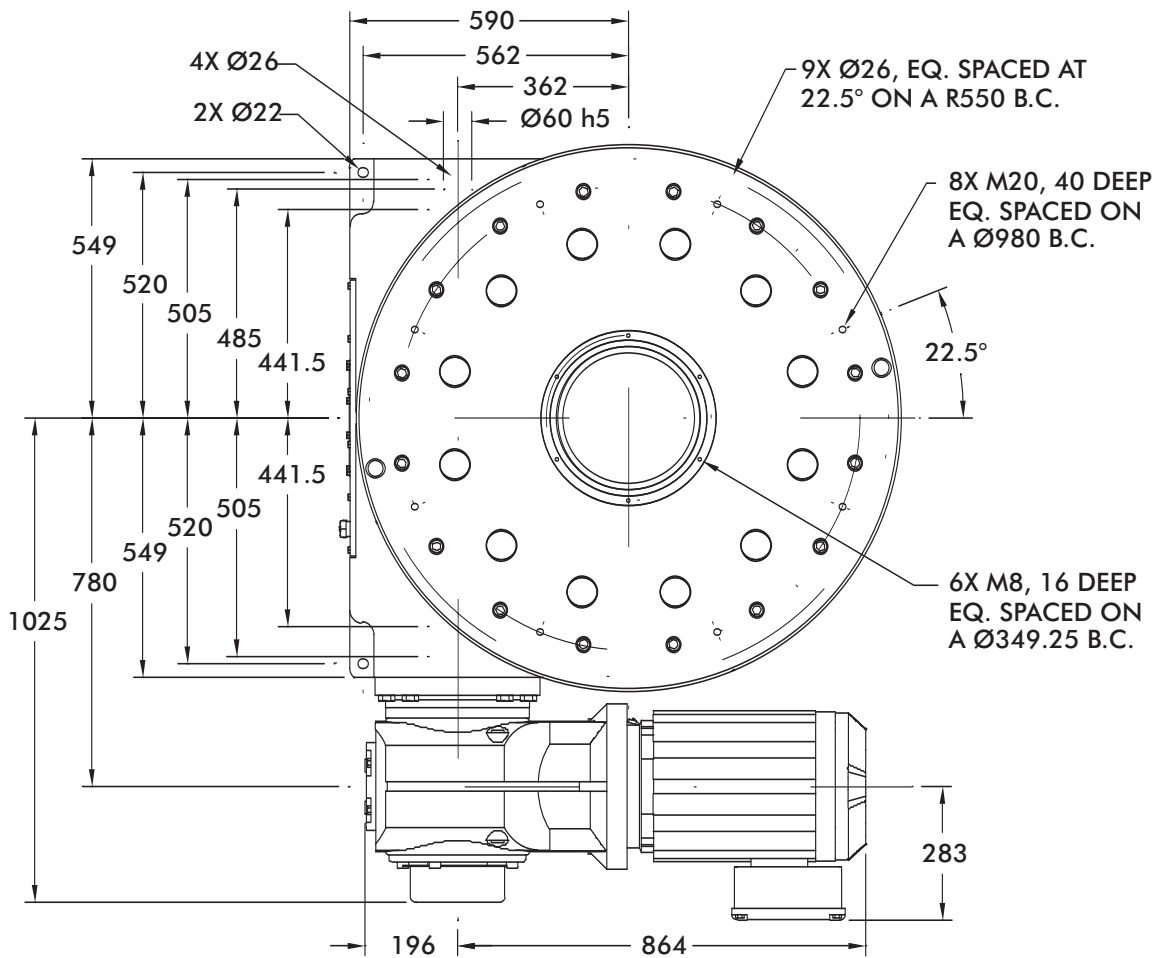

*281 OR 300 DEPENDING ON CAM MOTION

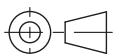

Unless otherwise noted,
all dimensions are in mm.

Dimensions and technical information are subject to change without notice.



1150E Product Overview, Technical Information, Optional Accessories

Maximum Inertia x 1,000 [lb-in ²] for standard package							
Stops	Motion Time [seconds]						
	0.89	1.29	1.52	1.75	2.03	2.24	2.52
2	134	1,141	2,093	3,329	4,746	5,835	7,501
3	698	2,965	5,108	7,887	11,077	13,526	17,275
4	1,445	5,474	9,284	14,225	19,896	24,249	30,915
6	3,780	12,845	21,419	32,537	45,296	55,090	70,088
8	6,581	21,959	36,502	54,381	73,624	89,397	113,548
12	15,621	50,221	82,944	123,772	167,569	203,468	258,436
16	27,975	61,083	84,884	111,420	150,846	183,162	232,645
Reducer Ratio							
	29.00	42.33	49.90	57.17	66.52	73.30	82.61

Features

- KH107 Gear Reducer with Brake-motor
- Double Extended Camshaft (Input shaft)
- Center Thru Hole (278 mm)
- Cycle Cam & limit Switch
- Right Hand Cam

Optional Accessories

- Left Hand Cam
- Relief in Dwell for Shot-Pin applications
- Dual Cam & limit Switch
- KH127 Gear Reducer with Brake-motor
- Stationary Center Post
- Visual Disk Dwell Indicator

Output Load Capacity (loads carried during index):

Radial	59,025 lbs
Thrust/Axial	85,470 lbs
Moment	1,469,000 in-lbs

Typical Application

Dial Diameter:	90 in. to 180 in.
Accuracy	±16 arcsec / ±.002" at 25" Radius
Repeatability	±4 arcsec / ±.0005" at 25" Radius

Dimensions and technical information are subject to change without notice.

1550E Standard Dimensions

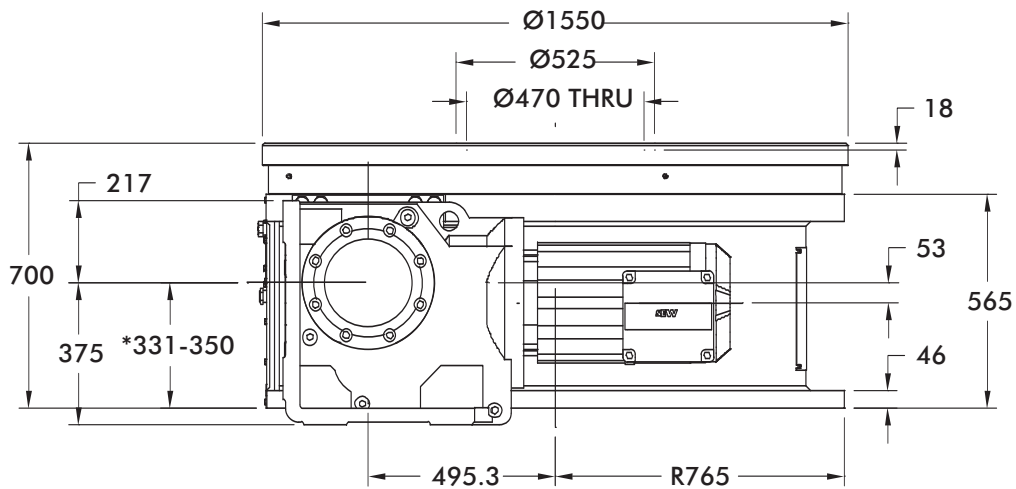
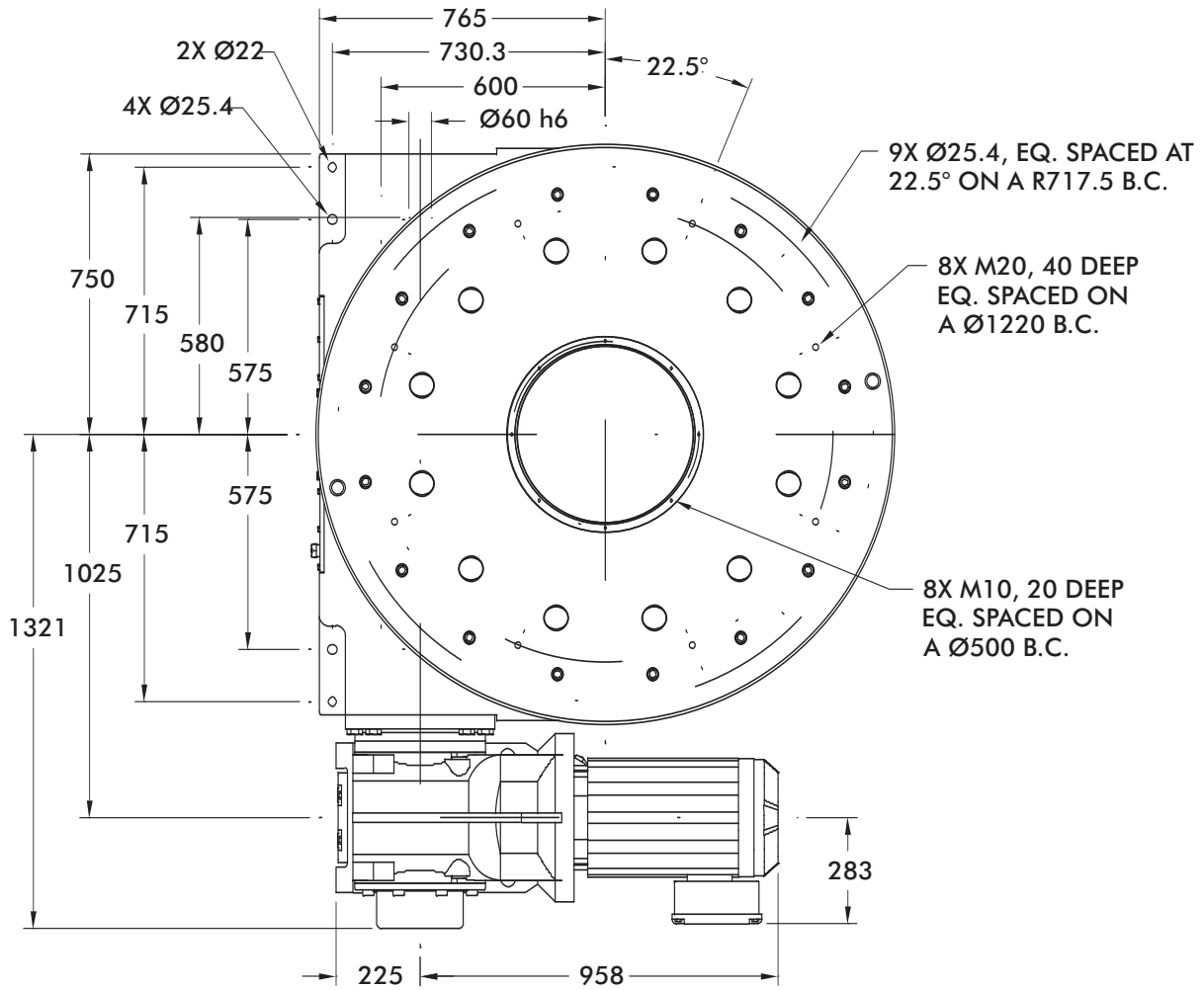

*331 OR 350 DEPENDING ON CAM MOTION

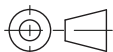

Unless otherwise noted, all dimensions are in mm.

Dimensions and technical information are subject to change without notice.



1550E Product Overview, Technical Information, Optional Accessories

Maximum Inertia x 1,000 [lb-in ²] for standard package							
Stops	Motion Time [seconds]						
	1.23	1.65	2.17	2.50	2.75	3.37	3.74
2	0	1,926	6,208	10,388	13,740	21,944	26,735
3	1,811	6,814	17,561	28,054	36,466	57,057	69,084
4	4,396	13,172	32,028	50,439	65,198	101,324	122,426
6	11,290	30,132	70,615	110,143	141,829	219,391	264,696
8	22,185	57,289	132,712	195,668	235,249	353,436	436,753
12	50,005	125,372	287,302	445,415	572,159	882,406	1,038,461
16	89,910	206,224	355,085	474,071	569,968	856,314	1,038,461
Reducer Ratio							
	40.19	54.07	70.95	81.98	89.89	110.18	122.48

Features

- KH127 Gear Reducer with Brake-motor
- Double Extended Camshaft (Input shaft)
- Center Thru Hole (470 mm)
- Cycle Cam and Limit Switch
- Right Hand Cam

Optional Accessories

- Left Hand Cam
- Relief in Dwell for Shot-Pin applications
- Dual Cam & limit Switch
- KH157 Gear Reducer with Brake-motor
- Stationary Center Post
- Visual Disk Dwell Indicator

Output Load Capacity (loads carried during index):

Radial	82,600 lbs
Thrust/Axial	120,000 lbs
Moment	2,904,000 in-lbs

Typical Application

Dial Diameter:	118 in. to 236 in.
Accuracy	±12 arcsec / ±.0017" at 30" Radius
Repeatability	±3 arcsec / ±.0004" at 30" Radius

Dimensions and technical information are subject to change without notice.



Notes

A large, empty grid of small squares, intended for handwritten notes or technical drawings.

Dimensions and technical information are subject to change without notice.

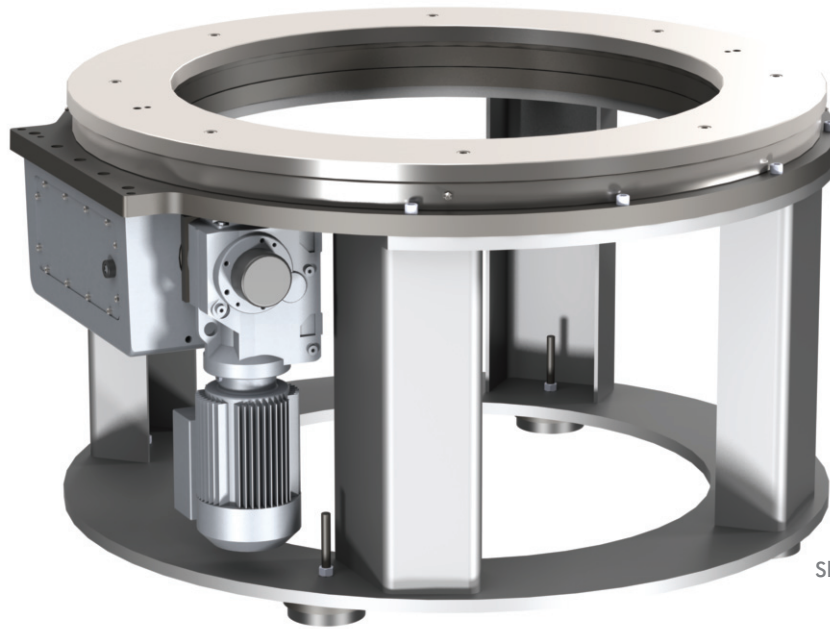

Shown with optional base

Work from Within

The **CAMCO Ring Drive** offers easy-to-integrate automation that fits easily into your operations.

- Minimize machine footprint: Mount your equipment inside the through-hole of the CAMCO Ring Drive.
- Easily tool the ring drive: Attach fixtures directly to the dial ring, eliminating the need for an additional dial plate.
- Best technical support and service: Worldwide access to our global network.

Applications

- Printing and decorating machines
- Rotary automatic assembly machines
- Ideal for assembly systems requiring a large number of tooling stations
- The Ring Drive can replace a small conveyor

Table of Contents

How to Order	80
750RNG	82
1100RNG	84
1550RNG	86

Licensed under U.S. Patent No. 5,950,503

Dimensions and technical information are subject to change without notice.

RNG Series How to Order

Base Model Description

- 750RNG** w/ KH37 reducer & 1 hp AC motor (220/440V)
- 1100RNG** w/ KH37 reducer & 1 hp AC motor (220/440V)
- 1550RNG** w/ KH37 reducer & 1-1/2 hp AC motor (220/440V)

Control Description

- 1** 1 hp 120V 750RNG & 1100RNG only
- 2** 1 hp 240V 750RNG & 1100RNG only
- 3** 1 hp 440V 750RNG & 1100RNG only
- 4** 2 hp 240V 1550RNG only
- 5** 2 hp 440V 1550RNG only



Motion	Stops	Index
A	6	330
B	8	330
C	12	330
D	16	330

Index Mounting
(See Figure 1)

1

Reducer Ratio

	750RNG	1100RNG	1550RNG
A	15.31	29.96	39.61
B	20.91	37.97	49.95
C	24.99	49.79	63.30
D	29.96	58.60	69.84
E	37.97	67.80	75.20
F	49.79	72.54	85.12
G	58.60	83.69	90.86

Reducer Mounting
(See Figure 3)

A
B

Signal Switch

M Mechanical
P Proximity

Signal Switch Side
(See Figure 2)

S Shaft

Example: MS or PS

Note about signal switch options:
 a) Mechanical is a single switch with cam.
 b) Proximity option is a mounting bracket for 8 or 12 mm proximity switch. A proximity switch will not be supplied. Cam supplied as target.

Other Motions (stops and index periods) available. Contact your DE-STA-CO sales representative for more information.

Ring Drive Features

Great Design Flexibility

- Available in three sizes: .75, 1.1 and 1.6 meter diameters
- Complete motorized drive package with reducer and AC inverter drive to suit most applications
- Dial Ring can be removed for machining to mounting your tooling and fixtures.
- Large center through-hole to accommodate auxiliary equipment
- 60 station capability, ideal for multiple part automatic assembly machines
- Steel Dial Ring or optional Aluminum Ring
- Broad range of motions/drive packages

Robust And Reliable

- Superior accuracy, similar to a precision link conveyor - your work station is located over the cam for maximum accuracy.
- High precision, hardened cams available in standard and special motions
- Sealed 4-point contact output bearing and large cam followers for superior accuracy and load capability (models 750RNG, 1100RNG and 1550RNG)
- Modular shaft-mounted reducers for application flexibility and easy maintenance
- Access to cam followers for easy inspection and replacement
- Tapered roller bearings on camshaft

Dimensions and technical information are subject to change without notice.

Input Shaft Configuration/Rotations (Figure 1)

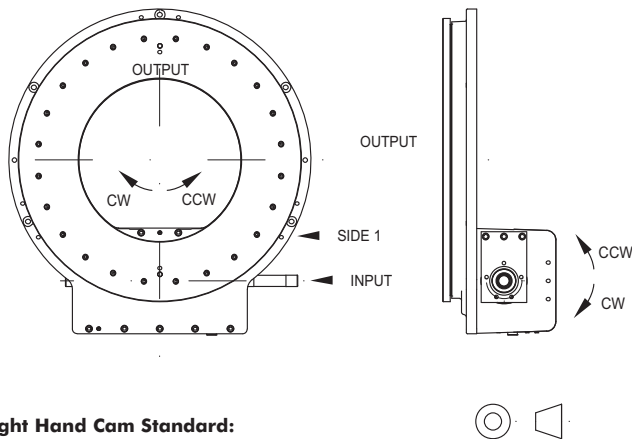

Right Hand Cam Standard:

CW Input Side 1, CCW Output
 CCW Input Side 1, CW Output

NOTE: Input can be driven in either direction

Signal Switch Mounting Position (Figure 2)

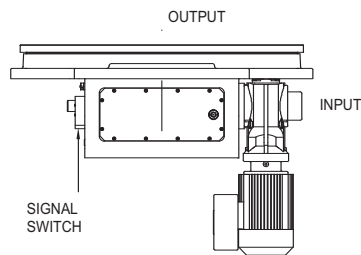

Gear Reducer Mounting Positions (Figure 3)

MOUNTING "A"

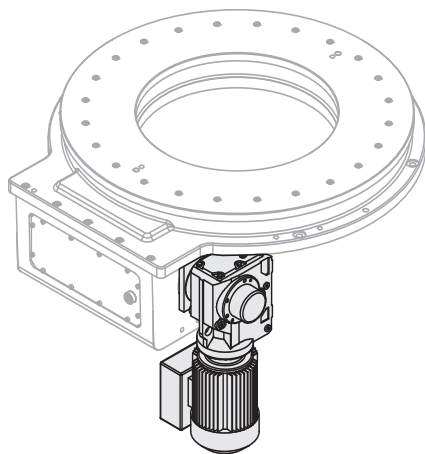

MOUNTING "B"

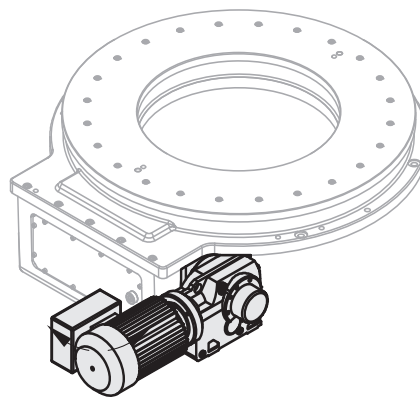

Dimensions and technical information are subject to change without notice.

750RNG Standard Dimensions

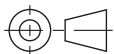
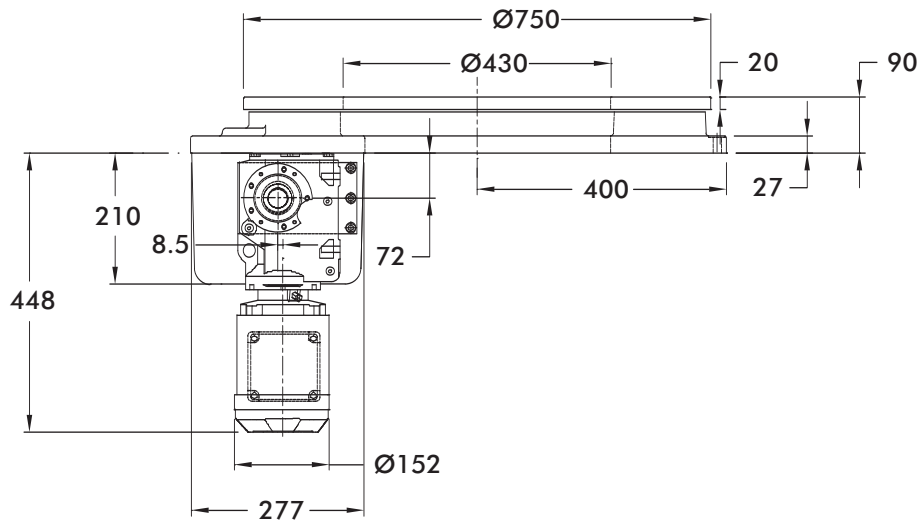
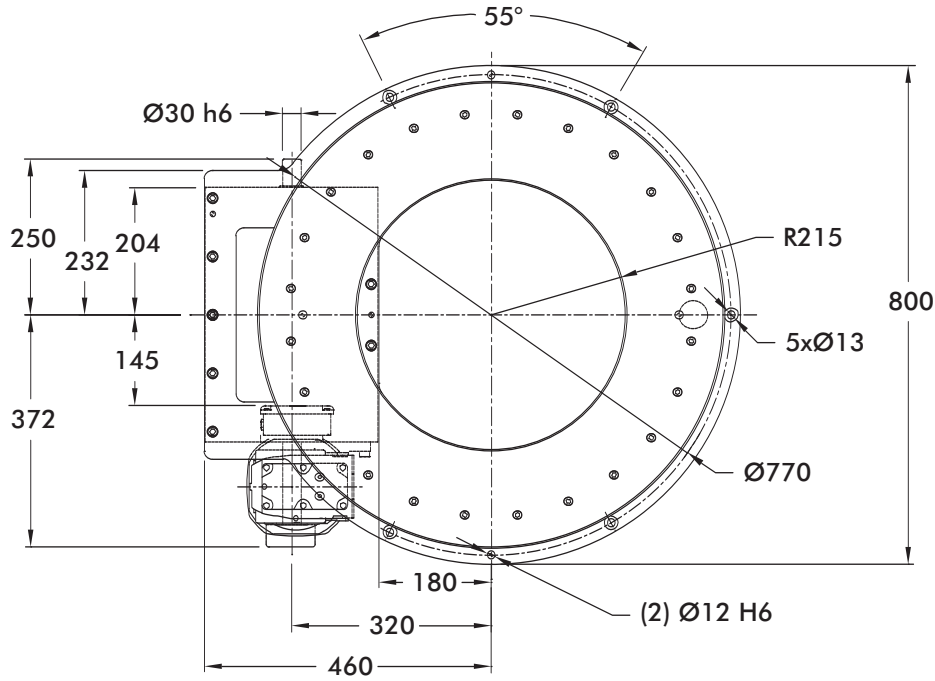

Unless otherwise noted,
all dimensions are in mm.

Dimensions and technical information are subject to change without notice.



750RNG Product Overview and Technical Specifications

Maximum Inertia x 1000 [lb-in ²] for standard package							
Stops	Motion Time [seconds]						
	0.468	0.617	0.764	0.915	1.160	1.521	1.791
6	0	17	58	124	292	565	791
8	3	47	121	238	537	1,022	1,424
12	36	134	300	564	1,237	2,328	3,233
16	81	255	550	1,019	2,217	4,156	5,765
Reducer Ratio							
	15.31	20.19	24.99	29.96	37.97	49.79	58.60

Features

- KH37 Reducer (Ratios from 15.31:1 to 58.6:1)
- 1 hp AC Drive Package with Inverter Duty Motor and IM-pAC AC Drive (up to 60 cpm)
- Double Extended Camshaft (Input Shaft)
- Center Thru Hole (230 mm. Diameter)
- Cycle Cam and Limit Switch Mounted to Camshaft
- Right Hand Cam

Output Bearing Capacity (loads carried during index):

- Radial 25,740 N [5,580 lbs]
- Axial 64,020 N [14,550 lbs]
- Moment 6,915 Nm [61,200 in-lbs]

Accuracy ±60 arcsec / ±.047 mm at 324" Radius
±.0019" at 12.75" Radius

Repeatability ±15 arcsec / ±.012 mm at 324" Radius
±.0005" at 12.75" Radius

Optional Accessories

- KH47 Reducer
- 2 hp AC Drive Package with Inverter Duty Motor and Commander SK AC Drive (up to 60 cpm)
- Dual Cam and Limit Switch
- Left Hand Cam
- AC brake Motor
- Aluminum dial ring
- Servo motor drive package with precision planetary reducer for applications requiring flexibility or fewer than 6 stations
- Custom dials & tooling plates
- Machined bases (see cover)

Dimensions and technical information are subject to change without notice.

1100RNG Standard Dimensions

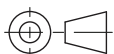
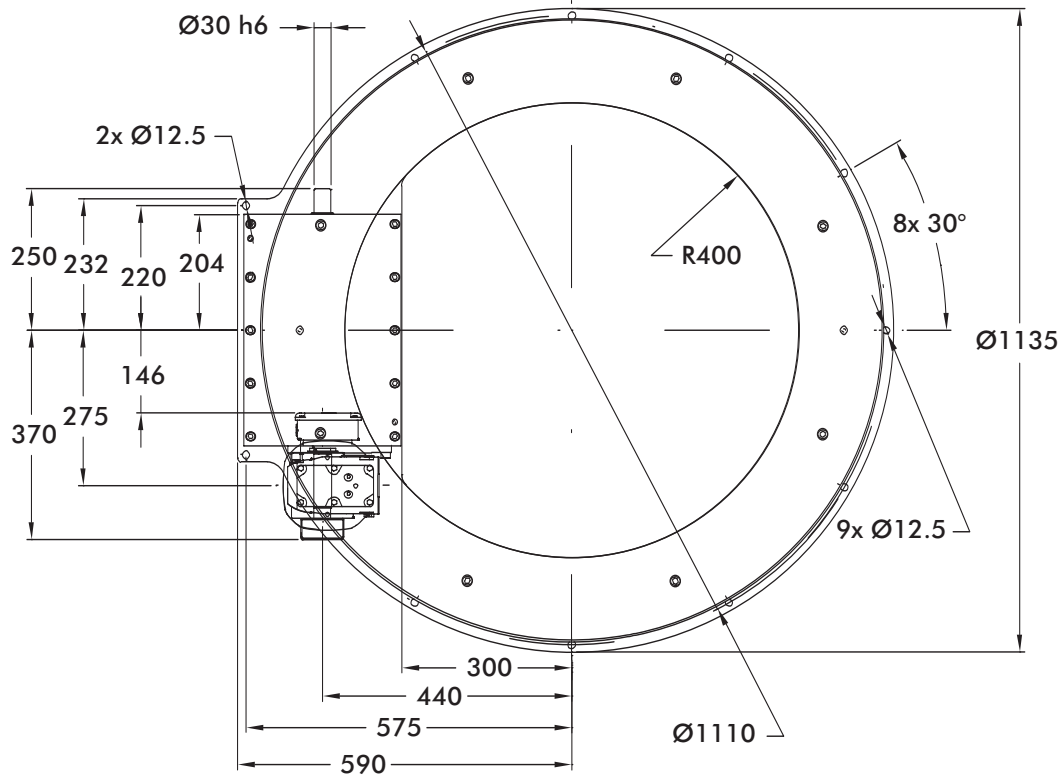

Unless otherwise noted, all dimensions are in mm.

Dimensions and technical information are subject to change without notice.



1100RNG Product Overview and Technical Specifications

Maximum Inertia x 1000 [lb-in ²] for standard package							
Stops	Motion Time [seconds]						
	0.915	1.359	1.521	1.791	2.072	2.217	2.557
6	56	378	497	724	999	1,157	1,570
8	170	743	954	1,357	1,847	2,127	2,861
12	496	1784	2,260	3,165	4,268	4,899	6,550
16	951	3,241	4,088	5,697	7,657	8,778	11,714
Reducer Ratio							
	29.96	37.97	49.79	58.60	67.80	72.54	83.69

Features

- KH37 Reducer (Ratios from 29.96:1 to 83.69:1)
- 1 hp AC Drive Package with Inverter Duty Motor and IM-pAC AC Drive (up to 60 cpm)
- Double Extended Camshaft (Input Shaft)
- Center Thru Hole (800 mm. Diameter)
- Cycle Cam and Limit Switch Mounted to Camshaft
- Right Hand Cam

Output Bearing Capacity (loads carried during index):

- Radial 159,940 N [36,350 lbs]
- Axial 72,829 N [16,552 lbs]
- Moment 16,879 Nm [149,376 in-lbs]

Accuracy ±35 arcsec / ±.038 mm at 448.30" Radius
±.0015" at 17.65" Radius

Repeatability ±9 arcsec / ±.010 mm at 448.30" Radius
±.0004" at 17.65" Radius

Optional Accessories

- KH47 Reducer
- 2 hp AC Drive Package with Inverter Duty Motor and Commander SK AC Drive (up to 60 cpm)
- Dual Cam and Limit Switch
- Left Hand Cam
- AC brake Motor
- Aluminum dial ring
- Servo motor drive package with precision planetary reducer for applications requiring flexibility or fewer than 6 stations
- Custom dials & tooling plates
- Machined bases (see cover)

Dimensions and technical information are subject to change without notice.

1550RNG Standard Dimensions

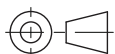
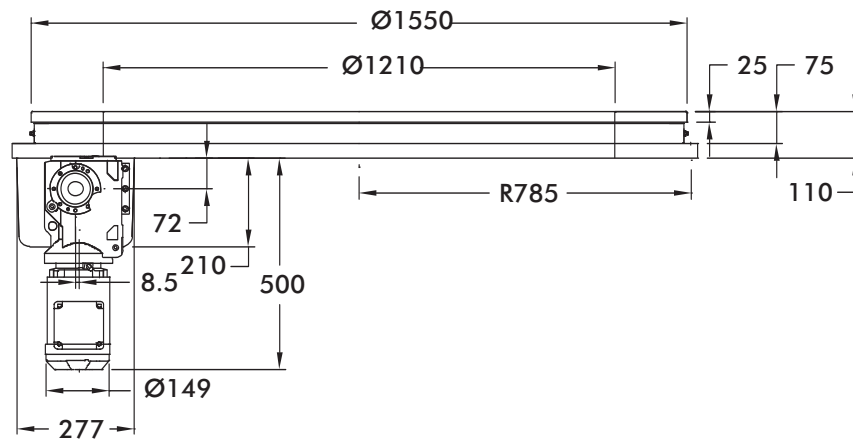
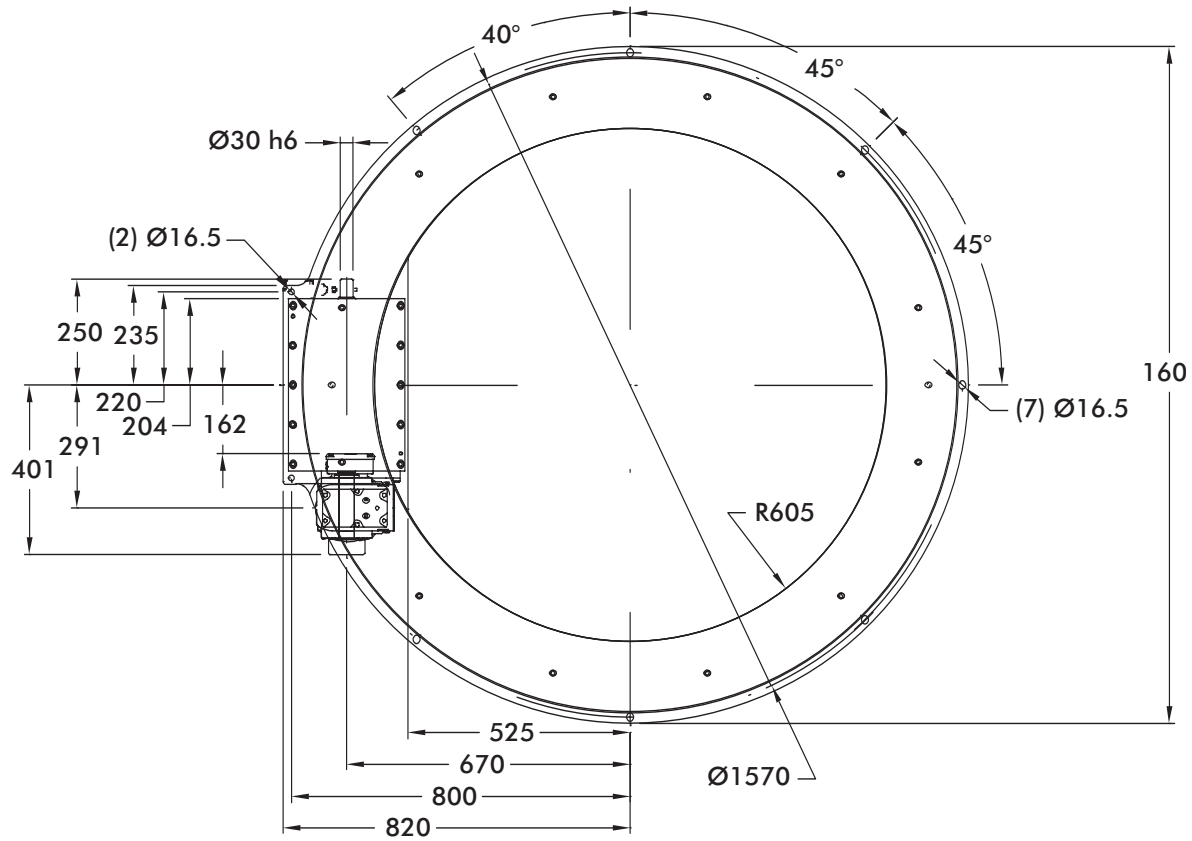

Unless otherwise noted,
all dimensions are in mm.

Dimensions and technical information are subject to change without notice.



1550RNG Product Overview and Technical Specifications

Maximum Inertia x 1000 [lb-in ²] for standard package							
Stops	Motion Time [seconds]						
	1.210	1.496	1.934	2.134	2.298	2.601	2.776
6	232	766	1,730	2,180	2,582	3,405	3,928
8	678	1,628	3,342	4,142	4,857	6,320	7,248
12	1,954	4,091	7,946	9,748	11,356	14,647	16,737
16	3,743	7,542	14,395	17,598	20,458	26,307	30,023
Reducer Ratio							
	39.61	48.95	63.30	69.84	75.20	85.12	90.86

Features

- KH47 Reducer (Ratios from 39.61:1 to 90.866:1)
- 2 hp AC Drive Package with Inverter Duty Motor and IM-pAC AC Drive (up to 60 cpm)
- Double Extended Camshaft (Input Shaft)
- Center Thru Hole (1210 mm. Diameter)
- Cycle Cam and Limit Switch Mounted to Camshaft
- Right Hand Cam

Output Bearing Capacity (loads carried during index):

- Radial 239,052 N [54,330 lbs]
- Axial 76,635 N [17,417 lbs]
- Moment 25,720 Nm [227,622 in-lbs]

Accuracy ±25 arcsec / ±.039 mm at 648.00" Radius
±.0015" at 25.51" Radius

Repeatability ±6 arcsec / ±.010 mm at 648.00" Radius
±.0004" at 25.51" Radius

Optional Accessories

- Dual Cam and Limit Switch
- Left Hand Cam
- AC brake Motor
- Aluminum dial ring
- Servo motor drive package with precision planetary reducer for applications requiring flexibility or fewer than 6 stations
- Custom dials & tooling plates
- Machined bases (see cover)

Dimensions and technical information are subject to change without notice.

RSD Series Product Overview



Flange output

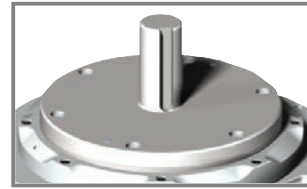

Shaft output

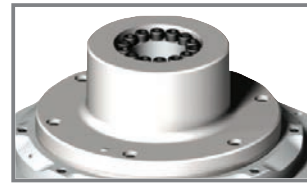

Internal shrink disk output



Shrink disk output

Smarter Indexing

The **CAMCO RSD Rotary Servo Drive** is a zero-backlash, cam-actuated drive compatible with industry-standard servo motors for precise control, efficiency and flexibility.

- Universal mounting
- Maintenance-free operation
- Large output bearing for greater overturning moment capacity
- Large thru-hole for accessory lines (electric, pneumatic, etc.)
- IP-65 rating
- Class 100 rated with Med-Redi preparation

Features

- Designed to accept a variety of servo motors
- Preloaded system
 - Zero backlash
 - High accuracy
 - Smooth motion
 - Quiet operation
 - High speed
- Indexing flexibility
 - Run different parts on the same indexer
 - Variable indexing: reversing, sorting, vary distance with each index
- 4:1 to 18:1 ratios in a single stage

Dimensions and technical information are subject to change without notice.

Model 115RSD Standard Dimensions

Flange Output

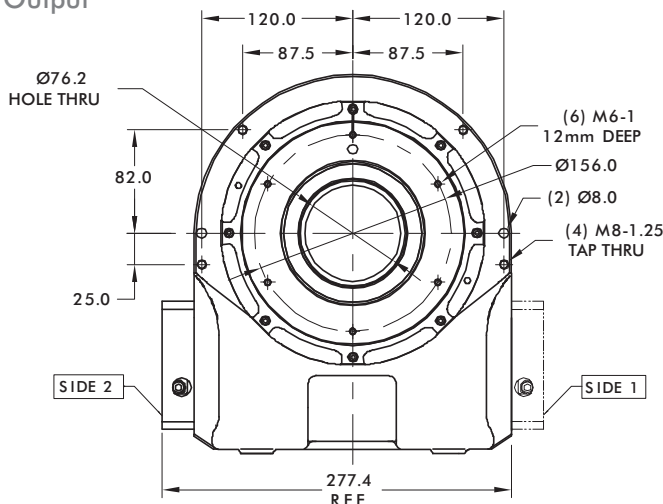
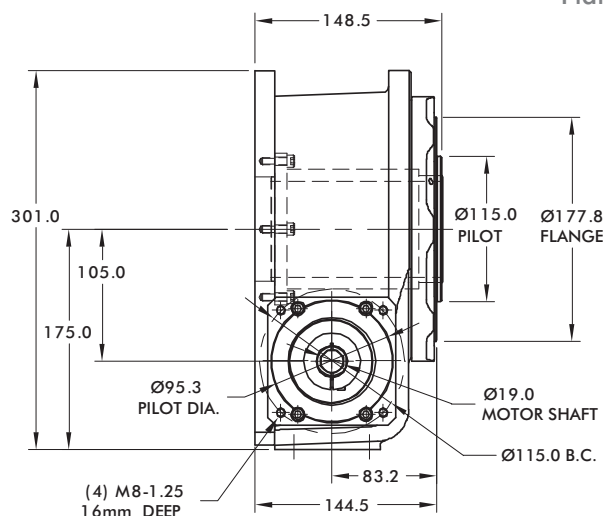

Shaft Output

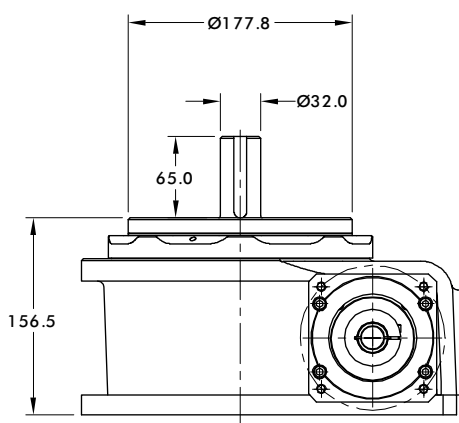

Internal Shrink Disk Output

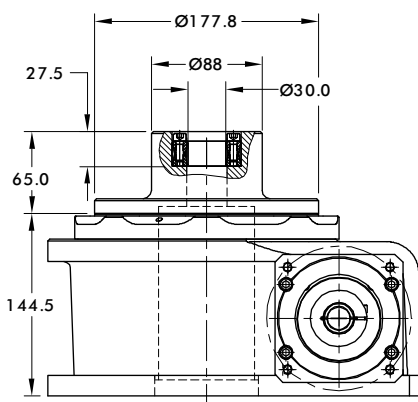

Shrink Disk Output

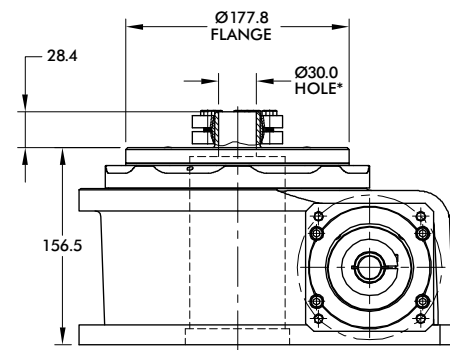

* Also available with 40mm bore.

Model 115RSD Technical Information

Specifications	Units	Standard Ratios		Other Available Ratios						
Single Reduction Ratio	-	8:1	16:1	4:1	5:1	6:1	9:1	12:1	15:1	18:1
Maximum Torque Capacity	in-lbs	3540	3755	2950	3195	3355	3595	3695	3740	3770
Maximum Inertia on Output Dial	lb-in ²	19,463	77,853	4,866	7,603	10,948	24,633	43,792	68,425	98,533
Unit Output Inertia Reflected at Input Shaft	lb-in ²	5.29	3.93	11.30	8.75	6.65	4.81	5.14	4.05	3.71
Stiffness	in-lbs/arcmin	169	179	141	153	160	172	177	179	180
Input Torque of Unit Only	in-lb	20		20						
Maximum Axial Load	Lbs	2,270		2,270						
Maximum Radial Load	Lbs	910		910						
Maximum Offset Load (Overturning Moment)	in-lb	3180		3,180						
Output Face Flatness	in. TIR	0.002		0.002						
Axial Run-Out	inches	0.0015		0.0015						
Accuracy	arc seconds	±30		±30						
Repeatability	arc seconds	±7		±7						
Torsional Backlash	arc seconds	0		0						
Operating Temperature Range	°F	40 Minimum		140 Maximum						

Dimensions and technical information are subject to change without notice.



Notes

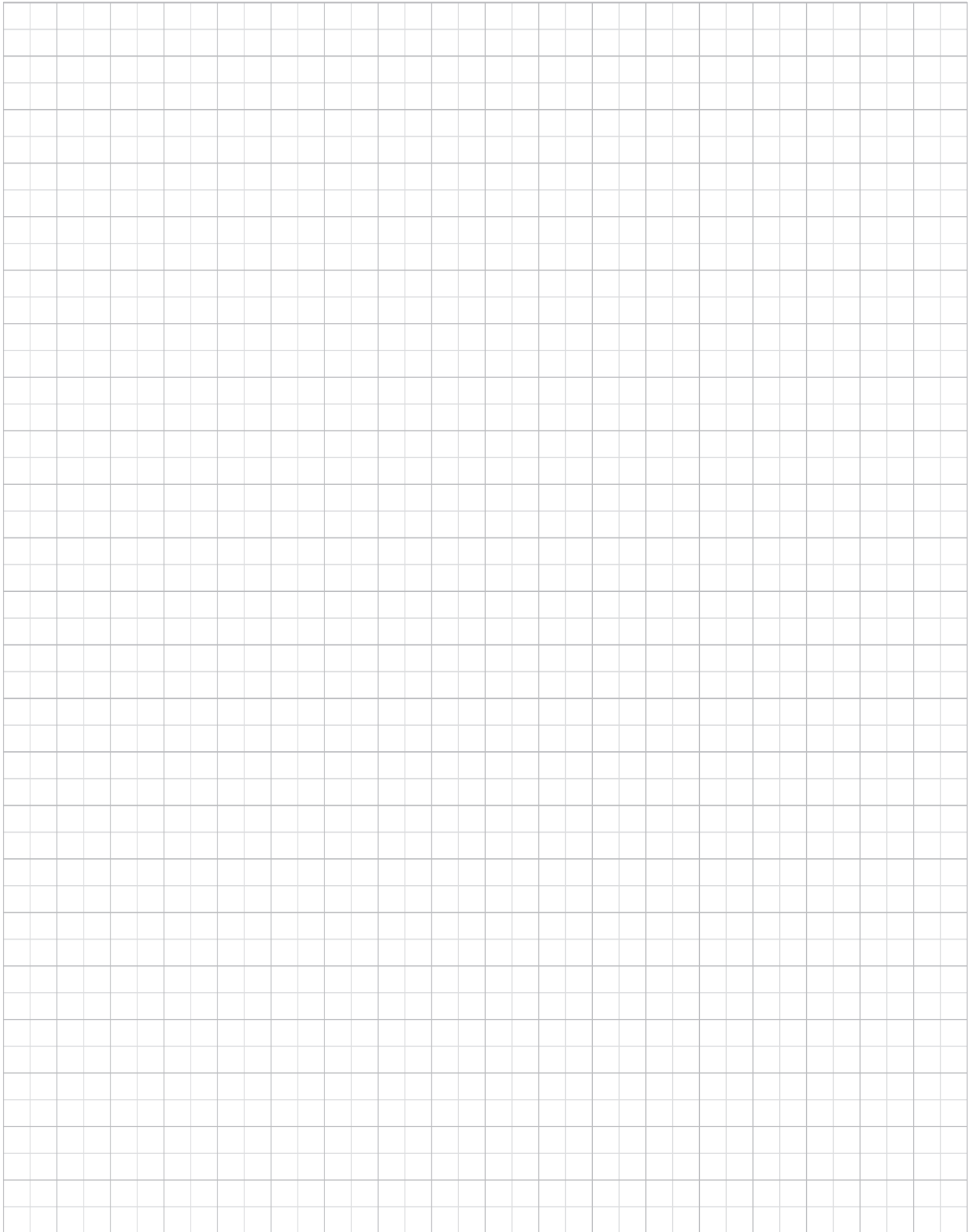

Dimensions and technical information are subject to change without notice.

The DX Drive is a programmable direct drive servo actuator with built-in safety relay designed for small flexible dial applications.

DX Series Features

- Easy setup and installation
- High accuracy and repeatability
- Quick response to reduce tact time
- Cam-profile motions provide smooth acceleration and deceleration
- Permanent lubrication for zero maintenance
- Energy saving: power is consumed only during indexing
- Separate actuator and control power supply
- Semi-automatic tuning function

Safety standards

- IEC standards, category 3, for safe torque off function

Conformity marks

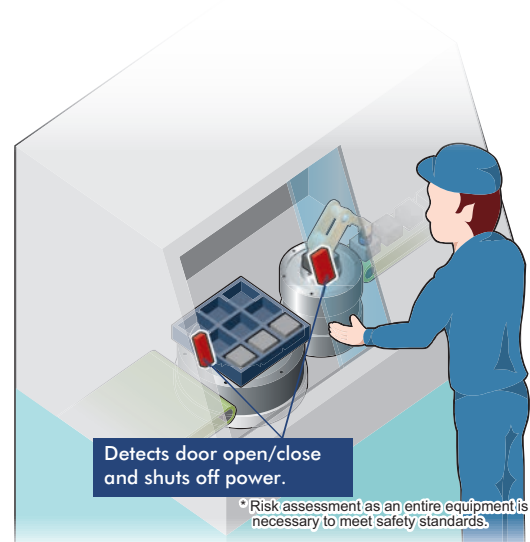
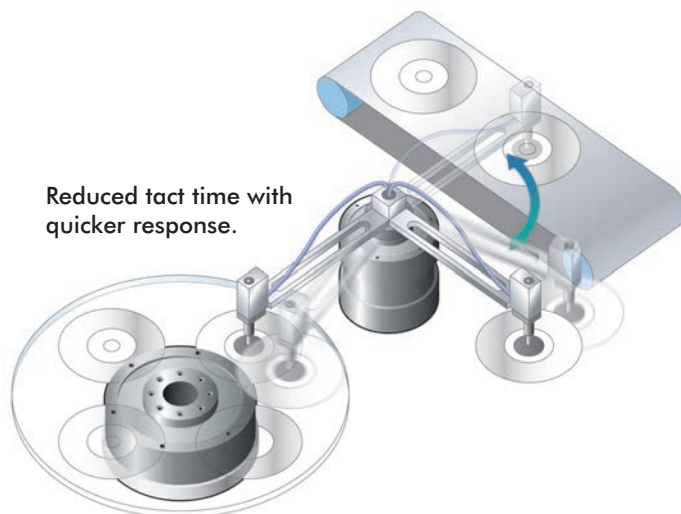

Bring safety to a machine by linking the drive.

Dimensions and technical information are subject to change without notice.

Quick response

Quick response and stabilization time with a fast CPU for quick tact time.

Output encoder

A-B phase output of current position for easy position control.

□ Mounting hole eliminates the task of using a mounting bracket

□ Separate main power supply and control power supply makes it possible to cut off only the main power supply

□ Connector provided

Easy crimping-free wiring. Risks of electric shock lowered since the terminal is not exposed.

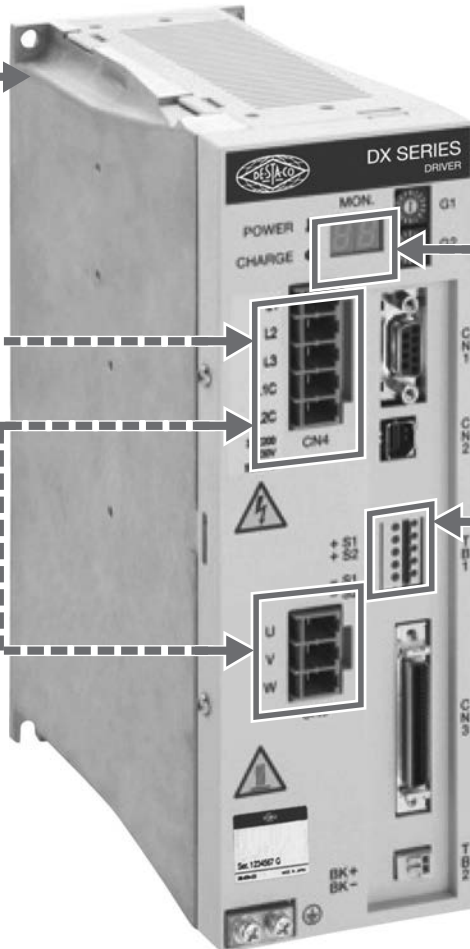

□ 7 segment LED 2-digit display

Alarm details indicator for easy maintenance. Gain Adjustment value also shown on LED.

□ Terminal for safety

Create a power cut-off circuit easily with the Safe Torque Off (STO) function

Supported fieldbus



Monitor with serial communication

Program number, position and alarm can be monitored from the PLC.

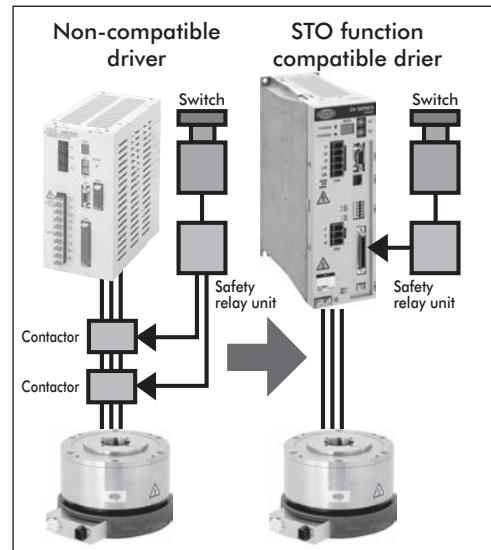
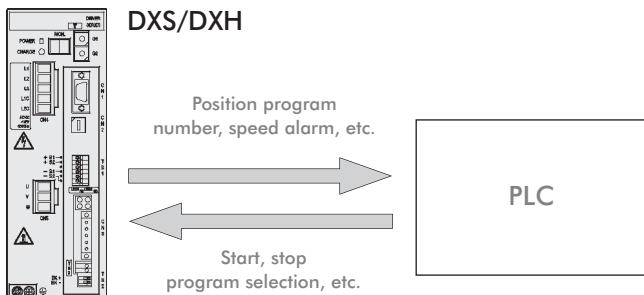

Installation of contactor for cutting off motor power is no longer required.

Dimensions and technical information are subject to change without notice.



Adjustment and installation support tool (DX tools) comes standard.

Get the right adjustments in less time.

Teaching note

- Create programs and set parameter
- Origin offset
- Trial run
- Semi-automatic tuning (DXS only)-
By adjusting one parameter after auto tuning, the equipment can achieve higher performance.

Speed wave

- Review the tuning by measuring the actual change in velocity and convergent time.

FFT

- Deter resonance of mechanisms by setting a notch filter and low-pass filter.

I/O check

- I/O status of host component and can be checked.

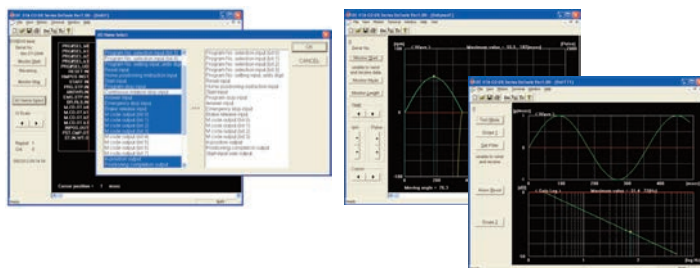

Features of the DX drive

Return to origin not required

- Because the DX drive has an absolute resolver that can detect the current position right after being turned on, there is no need to do a return- to-origin operation each and every time. Users may also restart from the current position as well as perform an emergency stop if necessary.

Smooth cam curve drive

- Five types of cam curves are installed as standard, which minimizes the shock during rotation and stop.

Model selection software (no additional charge)

- Select the model you need with ease.

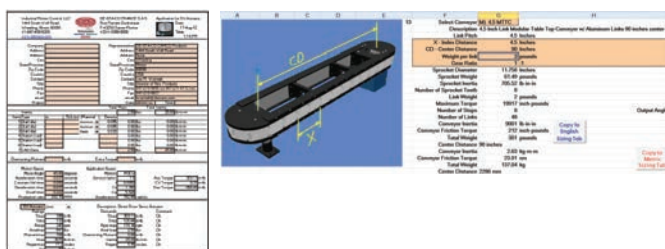

Additional functions

Input/output function

- Ready output
- Servo state output
- Encoder output
- Servo on input
- Position deviation counter clear input

Parameter

- Setting positioning complete signal output duration. Can be set h 0 to 100ms range.
- Mode selection of in-position input- Position output ON all the time within the in-position range or ON only when it is stopped within the in-position range.

Additional program selection method

- Select programs with 6-bit input (0 to 63)
- Operation start with selection input + start input
- Reduce tact time by reducing the time required to operate after program selection by abbreviating the program number setting input.

Prevents free-run when alarm is on

- Slows down and stops the servo when an alarm caused by coasting goes off to prevent accidents

Green technology

- **Energy saving**
Power is consumed only during indexing. Almost no power is used while the output shaft is stopped.
- **No need to replace or dispose lubricant**
Omits the need to replace and dispose of lubricants, eliminating pollution caused by oil leaks.
- **Smaller components, smaller equipment**
Does not require origin-detection sensor, reducer, etc.
- **Easy to change specifications, reusable**
Can be reused, unlike mechanical indexes, by changing specifications using computers and the teaching pendant.

Dimensions and technical information are subject to change without notice.

Basic settings

1. Input the program from a personal computer or from the teaching pendant.
2. Set required parameters the same way.
3. Set the appropriate gain.

Basic drive methods

1. PLC Select Program.
2. PLC provides start signal.
3. Completed signal will be outputted from the driver after the movement.

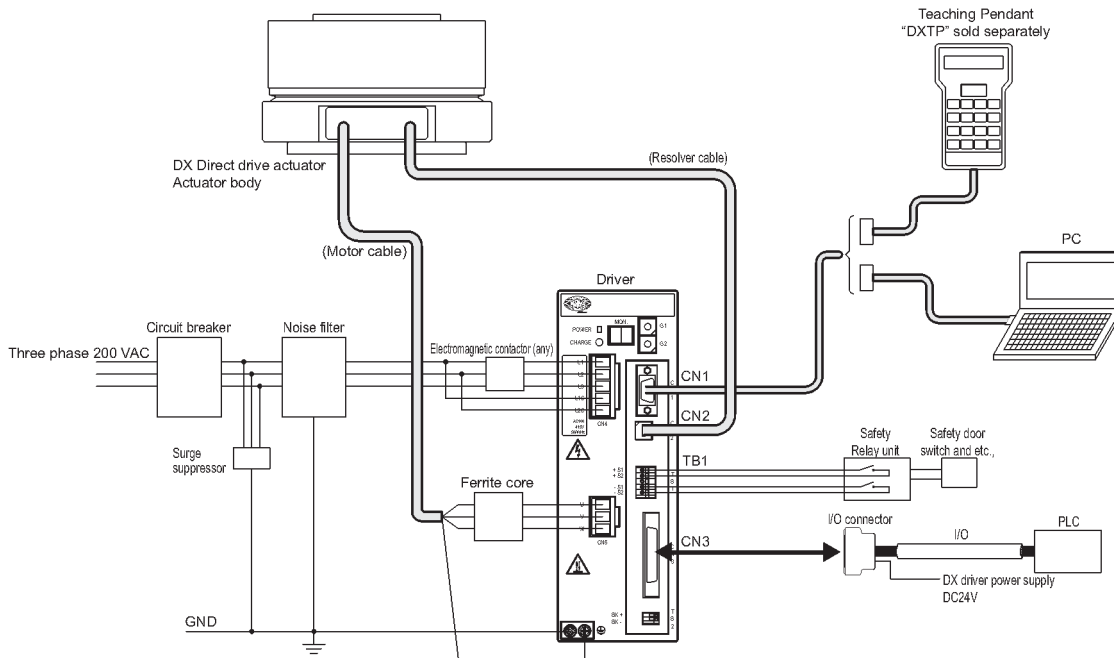

The parts listed here and over current/short circuit protection components are required to comply with the CE marking. Also, the driver must be placed with the switch board. Refer to the manual or technical documents for DX Series S/H type to find out how to install them.

Product name	Application	Model no.	Manufacturer
Noise filter	Three phase/single phase AC200V to 230V	3SUP-EF10-ER-6	Okaya Electric
	Single phase AC100V to 115V	NF2015A-OD	Soshin Electric
Ferrite core	Common	RC5060	Soshin Electric
Surge protector	Common	R/AV-81BXZ-4	Okaya Electric
FG clamp*	Common	FGC-5, FGC-8	Kitagawa Industries

*FG clamp is used to earth the shield for actuator cable and resolver cable.

Name	Quantity
Actuator body	1
Driver (with controller)	1
Actuator cable and resolver cable	1 each

Accessories; I/O connector, connector for power supply, connector for actuator cable

Programming Tool

- Teaching pendant "DXTP" available.
- Adjustment and installation support tool (DX tools) available. (Free, OS:Windows)
- Create and save programs, set parameters, enter commands using a PC. Communication cable RS-232C (for 9 pin D-sub(2m) model no.:DXRS232) is required.

Note: The communication cable is designed only to be used for the DX series. If other cables are used, the drive and PC may be damaged.

Note: Disconnect the teaching pendant or PC from CN1 during normal operation. Connect them only during setting and adjustment.

Note: Do not put the PC in stand-by with the USB-Serial conversion cable is connected. This will result in an error after returning from stand-by.

Dimensions and technical information are subject to change without notice.



The Safe Torque Off function allows you to turn off the actuator by opening/closing the external safety component. An example of a timing chart using the STO terminal (TB1) is shown below.

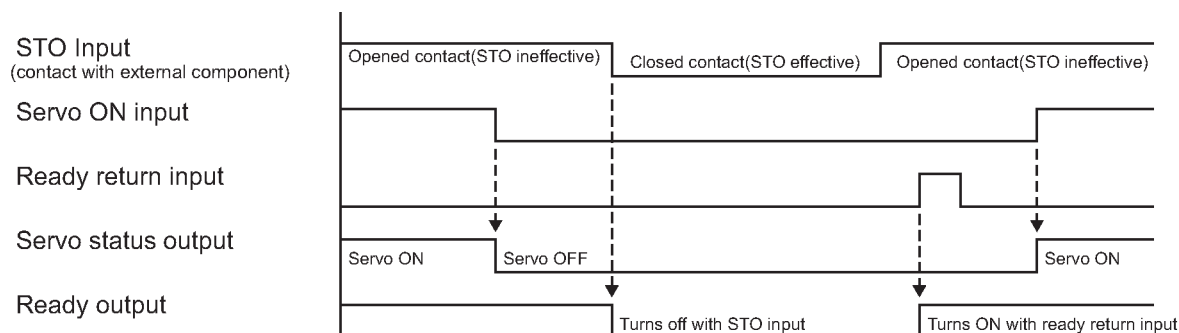





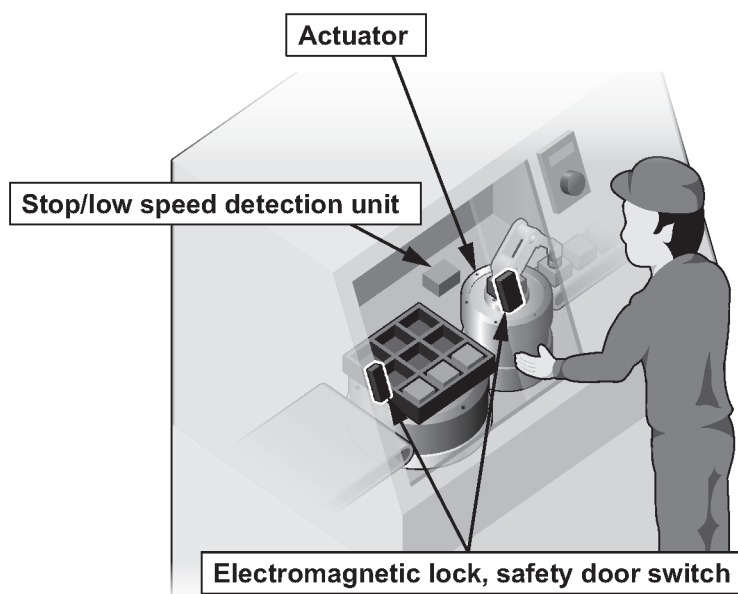



Use the Safe Torque Off (STO) function with the servo off in normal conditions. Always conduct a risk assessment of your equipment when using the STO function.

Example



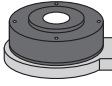
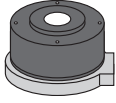

Dimensions and technical information are subject to change without notice.

Series		Torque (Nm)							
		6	9	12	18	22	45	75	150
DX Series Actuator		 DX6		 DX12	 DX18				
			 DX9			 DX22	 DX45	 DX75	 DX150
Compatible driver	DXS type Driver								
	DXH type Driver								

Dimensions and technical information are subject to change without notice.

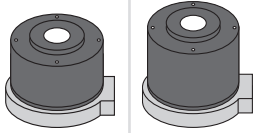

Torque (Nm)			Index Accuracy (sec.)	Repeatability (sec.)	Features	Applications	Page
210	300	500					
			±30	±5	High-speed rotation (300rpm). Small diameter and low profile. Max diameter of thru hole (Ø30). (see page 98 for details)	Pick and place Turntable Assembly machine	98
	 DX300 DX500		±30	±5	High-speed rotation (DX9: 240rpm, DX45:240rpm, DX75:140rpm). Capable of handling large moment of inertia. Max diameter of thru hole (Ø85). (see pages 99-100 for details)	Turntable Inspection machine Assembly machine Pick and place	99
			One driver can operate actuators of any size that are compatible. The controller function enables the actuator's rotation angle, movement time and timer, etc., to be set as desired with an NC program. Data is exchanged with an external PLC using M code output, etc.				113

Dimensions and technical information are subject to change without notice.

DX Series Product Overview



Features

- High speed rotation(max. 300rpm)
Low profile, large hollow diameter (Ø30)
- Max. torque: 6/12, 18 Nm
- Compatible driver: DXS type driver

DX Series Technical Specifications

Descriptions		DX6	DX12	DX18
Maximum output torque	Nm	6.0	12.0	18.0
Continuous output torque	Nm	2.0	4.0	6.0
Max. rotation speed	rpm	300 (Note 1)		
Allowable axial load	N	1000		
Allowable moment load	Nm	40		
Output shaft moment of inertia	kg-m ²	0.00575	0.00695	0.00910
Allowable load moment of inertia	kg-m ²	0.3	0.4	0.5
Index precision	sec.	±30		
Repeatability	sec.	±5		
Output shaft friction torque	Nm	0.6		0.7
Resolver resolution	P/rev	540672		
Actuator isolation class		Class F		
Actuator withstanding voltage		1500 VAC for one minute		
Actuator isolation resistance		10MΩ 500 VDC and over		
Ambient temperature range		0 to 45°C		
Ambient humidity range		20 to 85%RH with no dew condensation		
Storage ambient temperature range		-20 to 80°C		
Storage ambient humidity range		20 to 90%RH with no dew condensation		
Atmosphere		No corrosive gas, flammable or powder dust		
Weight	kg	4.7	5.8	7.5
Run out of output shaft	mm	0.03		
Surface run out of output shaft	mm	0.03		
Protection		IP20		

Note1: The speed must be kept below 80rpm during continuous rotation.

DX6

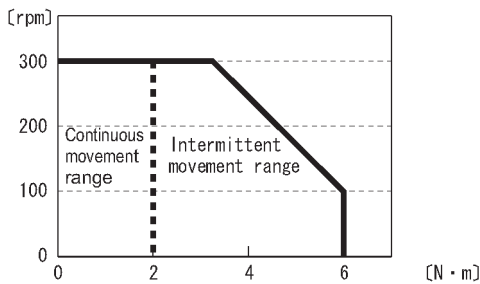

*This graph shows the characteristics under 3 phase AC200V

DX12

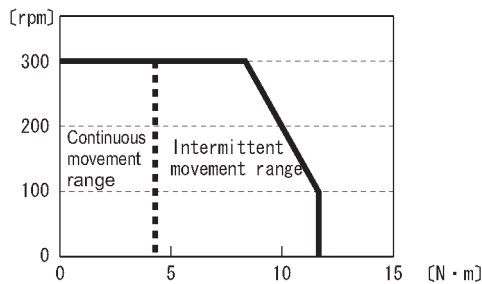

*This graph shows the characteristics under 3 phase AC200V

DX18

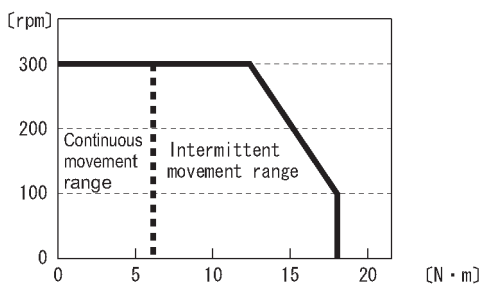

*This graph shows the characteristics under 3 phase AC200V

(Note)Moment load

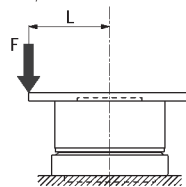

(Fig. a)

$$M(N \cdot m) = F(N) \times L(m)$$

M : Moment load

F : Load

L : Distance from output shaft center

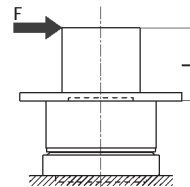

(Fig. b)

$$M(N \cdot m) = F(N) \times (L + 0.02)(m)$$

M : Moment load

F : Load

L : Distance from output shaft flange

Dimensions and technical information are subject to change without notice.



DX Series Product Overview

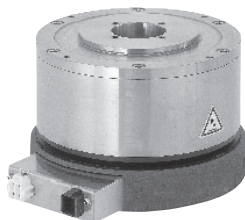

Features

- Resistance to load of large moment of inertia
- Wide variety of options
- Easier to pipe and wire with large inner diameter
- Max. torque: 9/22, 45/75 Nm
- Compatible driver: DXS type driver

DX Series Technical Specifications

Descriptions		DX9	DX22	DX45	DX75
Maximum output torque	Nm	9	22	45	75
Continuous output torque	Nm	3	7	15	25
Max. rotation speed	rpm	240 (Note 1)			140 (Note 1)
Allowable axial load	N	800	3700		20000
Allowable moment load	Nm	40	60	80	200
Output shaft moment of inertia	kg-m ²	0.009	0.0206	0.0268	0.1490
Allowable load moment of inertia	kg-m ²	0.35 (1.75) (Note 2)	0.60 (3.00) (Note 2)	0.90 (5.00) (Note 2)	5.00 (25.00) (Note 2)
Index accuracy	sec.	±30			
Repeatability	sec.	±5			
Output shaft friction torque	Nm	0.8	3.5		10.0
Resolver resolution	P/rev	540672			
Actuator isolation class		Class F			
Actuator withstanding voltage		1500 VAC for one minute			
Actuator isolation resistance		10MΩ 500 VDC and over			
Ambient temperature range		0 to 45°C			
Ambient humidity range		20 to 85%RH with no dew condensation			
Storage ambient temp. range		-20 to 80°C			
Storage ambient humidity range		20 to 90%RH with no dew condensation			
Atmosphere		No corrosive gas, flammable or powder dust			
Weight	kg	5.5	12.3	15.0	36.0
Brake total weight when set	kg	—	16.4	19.3	54.0
Run out of output shaft	mm	0.03			
Run out of output shaft surface	mm	0.05			
Protection		IP20			

Note1: The speed must be kept below 80rpm during continuous rotation.

Note2: When using within the load conditions shown in the parenthesis, set parameter 72 (multiplier for integral gain) to 0.3 (reference value).

Note3: Consult DE-STA-CO each time when using parameter 72 (multiplier for integral gain) during continuous rotation.

Descriptions		DX22/45	DX75
Type		Non-backlash dry non-excitation operation type	
Rated voltage	V	DC24V	
Power supply wattage	W	30	55
Rated current	A	1.25	2.30
Static friction torque	Nm	35	200
Armature release time (brake on)	msec	50 (reference value)	50 (reference value)
Armature suction time (brake off)	msec	150 (reference value)	250 (reference value)
Holding precision	Minute	45 (reference value)	
Max. cycle rate	Time/min.	60	40

Note 1: When the output shaft is rotating, rubbing noise may be generated at the electromagnetic brake's disk and fixing section.

Note 2: When moving after brakes are turned OFF, the delay time parameter must be changed based on armature suction time.

Note 3: This is a non-backlash type, but it may be hard to hold a set position if load is applied in the direction of rotation.

Note 4: When electromagnetic brakes function, the armature may contact the magnetic brake's fixed section and generate noise.

Note 5: Brakes are manually released by alternately screwing screws into manual release taps (3 positions). Lightly tighten screws until they stop, then turn them another 90°. When finished with manual release, remove the three bolts immediately and apply brakes.

Dimensions and technical information are subject to change without notice.



DX Series Product Overview

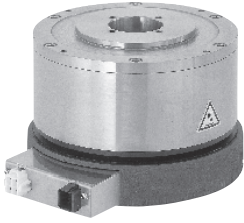

Features

- Capable of handling large moment inertia
- Wide variety of options
- Easier to pipe and wire with large inner diameter
- Max. torque: 150/300/500 Nm
- Compatible driver: DXH type driver

DX Series Technical Specifications

Descriptions		DX150	DX300	DX500
Maximum output torque	Nm	150	300	500
Continuous output torque	Nm	50	100	160
Max. rotation speed	rpm	100 (Note 1)		70
Allowable axial load	N	20000		
Allowable moment load	Nm	300	400	500
Output shaft moment of inertia	kg-m ²	0.2120	0.3260	0.7210
Allowable load moment of inertia	kg-m ²	75.00 (Note 2)	180.00 (Note 2)	300.00 (Note 2)
Index accuracy	sec.	±30		
Repeatability	sec.	±5		
Output shaft friction torque	Nm	10.0		15.0
Resolver resolution	P/rev	540672		
Actuator isolation class		Class F		
Actuator withstanding voltage		1500 VAC for one minute		
Actuator isolation resistance		10MΩ 500 VDC and over		
Ambient temperature range		0 to 45°C		
Ambient humidity range		20 to 85%RH with no dew condensation		
Storage ambient temp. range		-20 to 80°C		
Storage ambient humidity range		20 to 90%RH with no dew condensation		
Atmosphere		No corrosive gas, flammable or powder dust		
Weight	kg	44.0	66.0	115.0
Total weight with brake	kg	63.0	86.0	-
Run out of output shaft	mm	0.03		
Run out of output shaft surface	mm	0.05		
Protection		IP20		

Note1: The speed must be kept below 80rpm during continuous rotation.

Note2: The default setting will be large inertia moment compatible

Descriptions		DX150/DX300
Type		Non-backlash dry non-excitation operation type
Rated voltage	V	DC24V
Power supply wattage	W	55
Rated current	A	2.30
Static friction torque	N•m	200
Armature release time (brake on)	msec	50 (reference value)
Armature suction time (brake off)	msec	250 (reference value)
Holding precision	Minute	45 (reference value)
Max. cycle rate	Time/min.	40

Note 1: When the output shaft is rotating, rubbing noise may be generated at the electromagnetic brake's disk and fixing section.

Note 2: When moving after brakes are turned OFF, the delay time parameter must be changed based on armature suction time.

Note 3: This is a non-backlash type, but it may be hard to hold a set position if load is applied in the direction of rotation.

Note 4: When electromagnetic brakes function, the armature may contact the magnetic brake's fixed section and generate noise.

Note 5: Brakes are manually released by alternately screwing screws into manual release taps (3 positions). Lightly tighten screws until they stop, then turn them another 90°. When finished with manual release, remove the three bolts immediately and apply brakes.

Dimensions and technical information are subject to change without notice.



DX Series How To Order

DX75
B -
 D
A

<p>Actuator</p> <p>DX6 DX Actuator 2 nm rms and 6 nm peak torque</p> <p>DX12 DX Actuator 4 nm rms and 12 nm peak torque</p> <p>DX18 DX Actuator 6 nm rms and 18 nm peak torque</p> <p>DX9 DX Actuator 3 nm rms and 9 nm peak torque</p> <p>DX22 DX Actuator 7 nm rms and 22 nm peak torque</p> <p>DX22-BR DX22 Actuator with Brake</p> <p>DX45 DX Actuator 15 nm rms and 45 nm peak torque</p> <p>DX45-BR DX45 Actuator with Brake</p> <p>DX75 DX Actuator 25 nm rms and 75 nm peak torque</p> <p>DX75-BR DX75 Actuator with Brake</p>	<p>Base</p> <p>B Black oxide plate for base (not available with -BR brake option)</p> <p>Driver</p> <p>220V Driver</p> <p>01 DXS200NPN, NPN I/O</p> <p>02 DXS200PNP, PNP I/O</p> <p>03 DXS200CCL, CC-Link Communications Protocol</p> <p>04 DXS200PRO, Profibus Communications Protocol</p> <p>05 DXS200DVN, DeviceNet Communications Protocol</p> <p>115V Driver</p> <p>06 DXS100NPN, NPN I/O</p> <p>07 DXS100PNP, PNP I/O</p> <p>08 DXS100CCL, CC-Link Communications Protocol</p> <p>09 DXS100PRO, Profibus Communications Protocol</p> <p>010 DXS100DVN, DeviceNet Communications Protocol</p>	<p>Cable Set*</p> <p>AA 2 meters</p> <p>BB 4 meters</p> <p>CC 6 meters</p> <p>DD 8 meters</p> <p>EE 10 meters</p> <p>FF 15 meters</p> <p>GG 20 meters</p> <p><small>* Includes resolver cable and motor cable of equal length.</small></p>
---	---	--

DX Series How To Order

DX150
B -
 L
A

<p>Actuator</p> <p>DX150 DX Actuator 50 nm rms and 150 nm peak torque</p> <p>DX150-BR DX150 Actuator with Brake</p> <p>DX300 DX Actuator 100 nm rms and 300 nm peak torque</p> <p>DX300-BR DX300 Actuator with Brake</p> <p>DX500 DX Actuator 150 nm rms and 500 nm peak torque</p>	<p>Base</p> <p>B Black oxide plate for base (not available with -BR brake option)</p> <p>Driver</p> <p>220V Driver</p> <p>011 DXH200NPN, NPN I/O</p> <p>012 DXH200PNP, PNP I/O</p> <p>013 DXH200CCL, CC-Link Communications Protocol</p> <p>014 DXH200PRO, Profibus Communications Protocol</p> <p>015 DXH200DVN, DeviceNet Communications Protocol</p>	<p>Cable Set*</p> <p>AA 2 meters</p> <p>BB 4 meters</p> <p>CC 6 meters</p> <p>DD 8 meters</p> <p>EE 10 meters</p> <p>FF 15 meters</p> <p>GG 20 meters</p> <p><small>* Includes resolver cable and motor cable of equal length.</small></p>
---	--	--

DX Series Options

- DXTP** Programmable Teaching Pendant (order separately)
- DXRS232** Serial Cable (order separately)

Dimensions and technical information are subject to change without notice.



For more information or to place an order, call 1-877-450-5200, 1-800-645-5207 or camco@destaco.com

destaco.com

DX Series Dimensions

DX6/DX6B

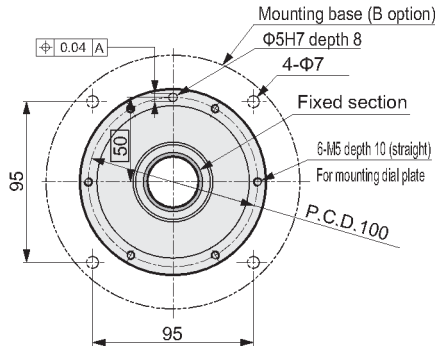

DX12/DX12B

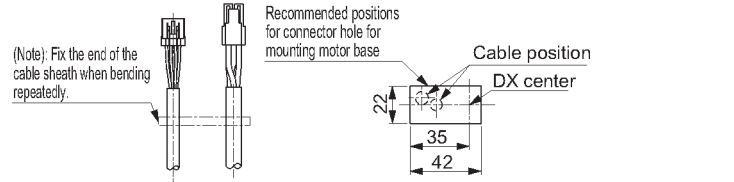
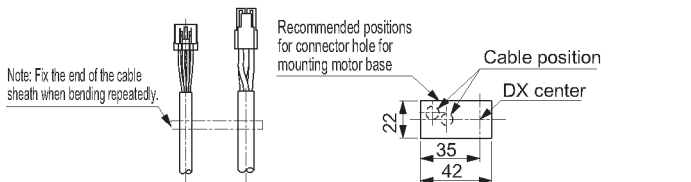
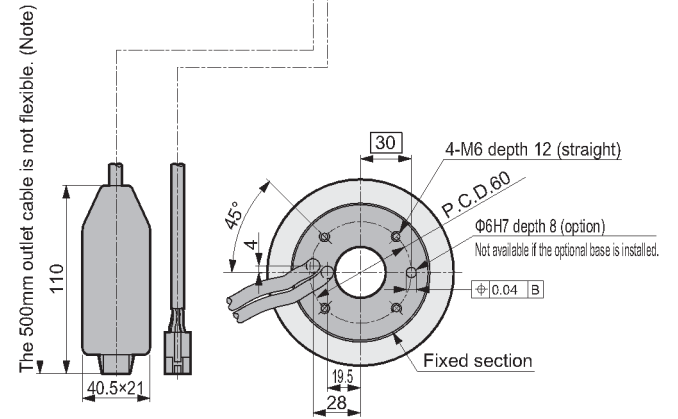
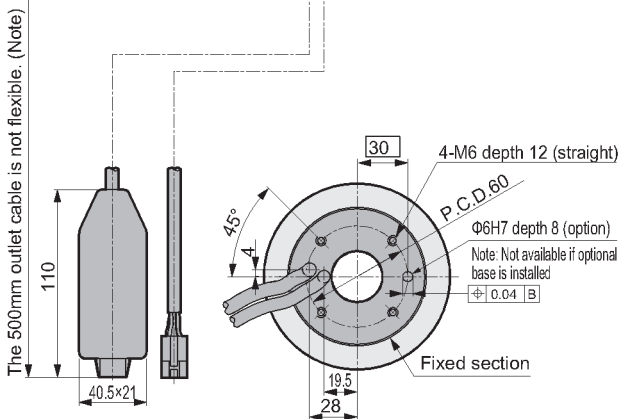
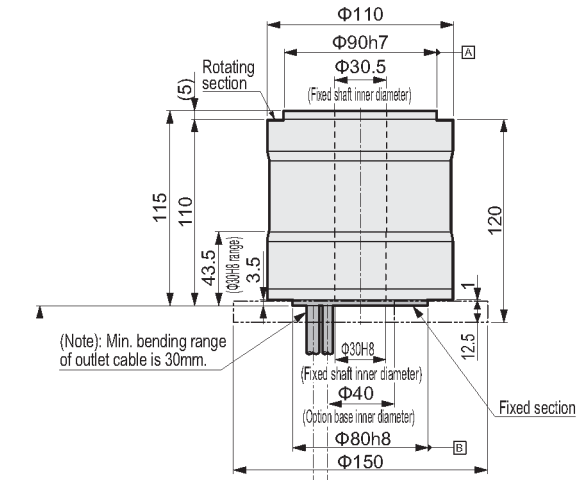
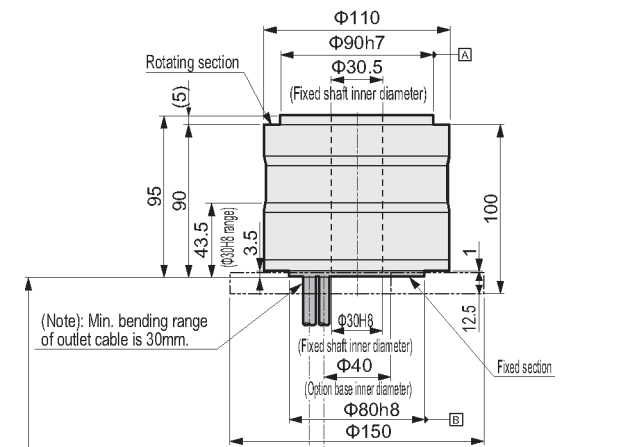
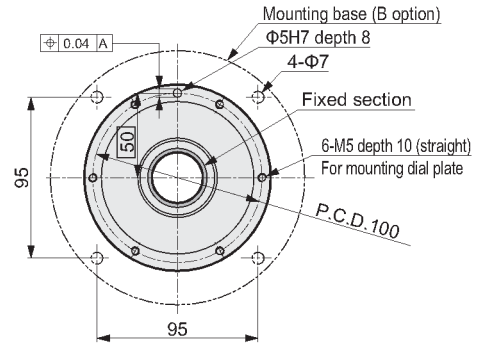

The origin of the actuator may differ from the dimensions shown above. Origin can be configured randomly using the origin offset function.

Dimensions and technical information are subject to change without notice.

DX18/DX18B

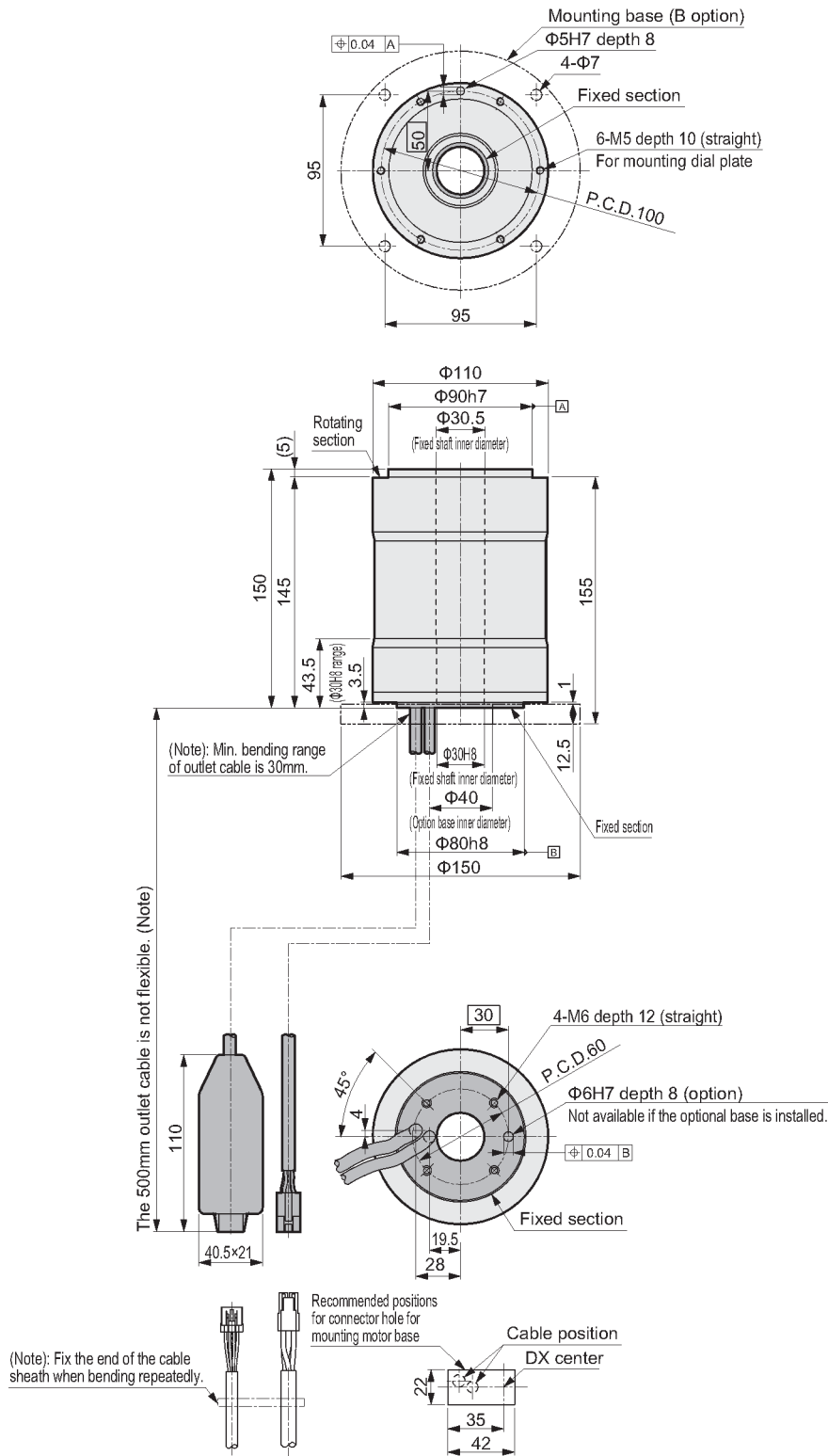

The origin of the actuator may differ from the dimensions shown above. Origin can be configured randomly using the origin offset function.

Dimensions and technical information are subject to change without notice.

DX Series Technical Specifications

DX9

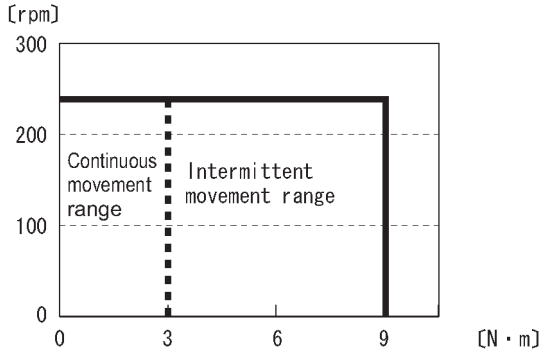

*This graph shows the characteristics under 3 phase AC200V

DX22

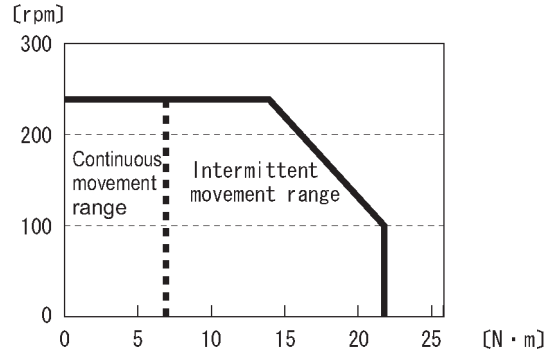

*This graph shows the characteristics under 3 phase AC200V

DX45

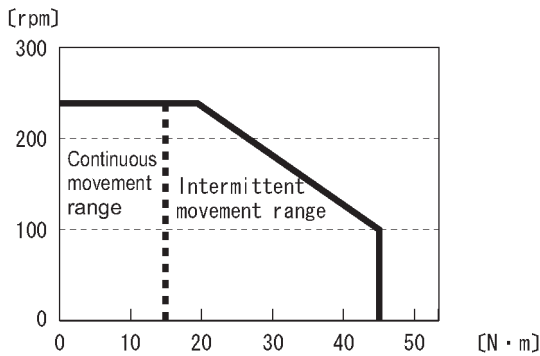

*This graph shows the characteristics under 3 phase AC200V

DX75

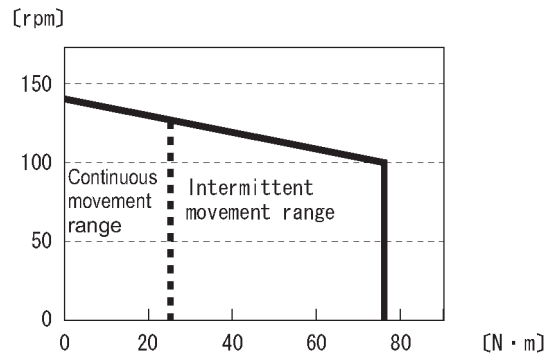

*This graph shows the characteristics under 3 phase AC200V

(Note) moment load

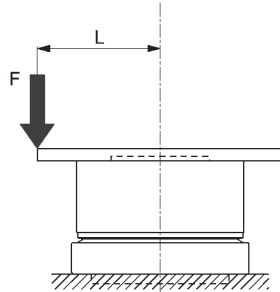

(Fig. a)

$M(N\cdot m) = F(N) \times L(m)$
M: Moment load
F: Load
L: Distance from output shaft center

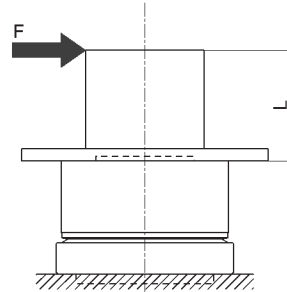

(Fig. b)

$M(N\cdot m) = F(N) \times (L + 0.02)(m)$
M: Moment load
F: Load
L: Distance from output shaft flange

Dimensions and technical information are subject to change without notice.

DX9

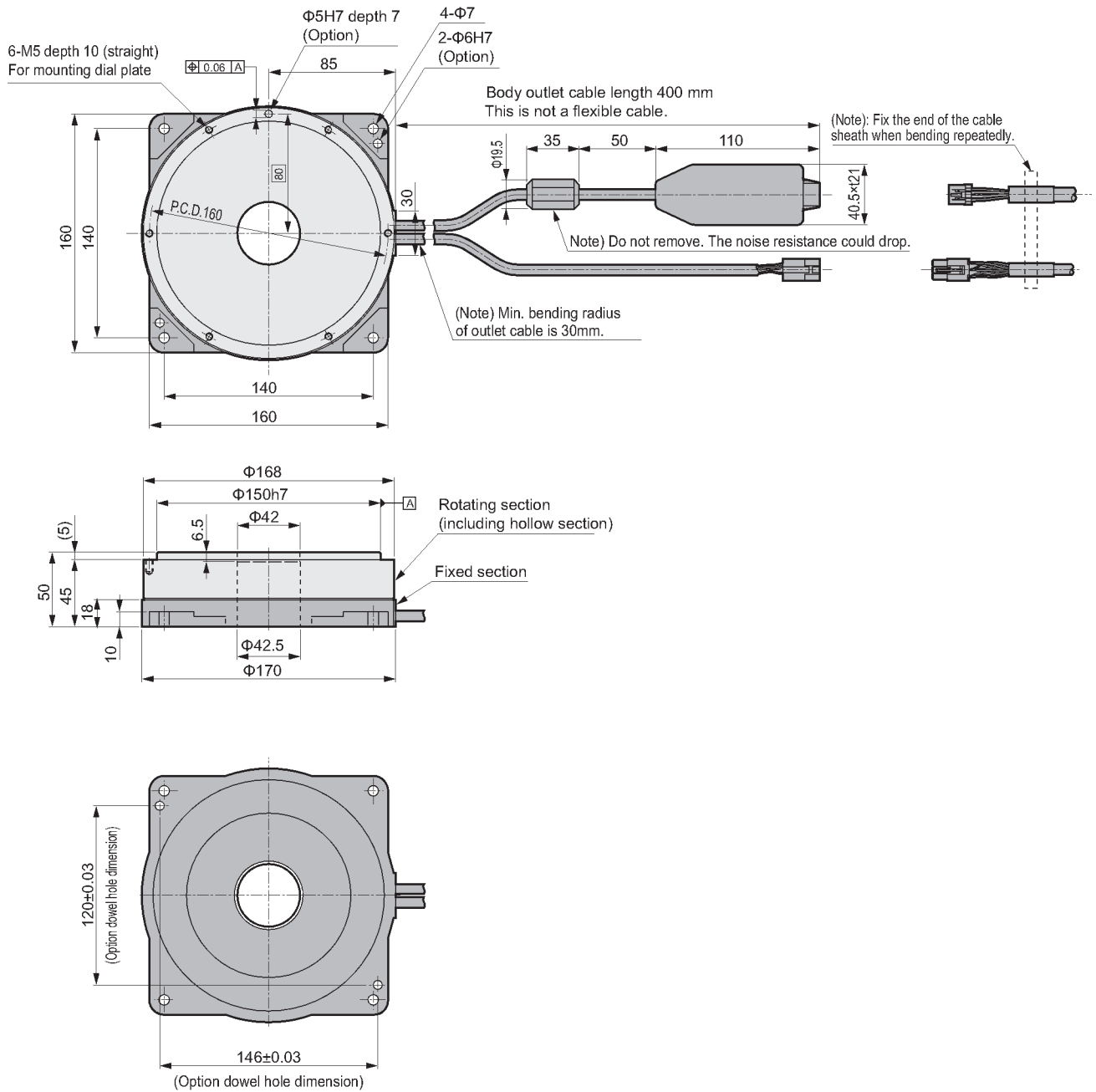

The origin of the actuator may differ from the dimensions shown above.
Origin can be configured randomly using the origin offset function.

Dimensions and technical information are subject to change without notice.

DX Series Dimensions

DX22/DX22B

DX22-BR (optional)

With electromagnetic brake
Refer to the left drawings for options.

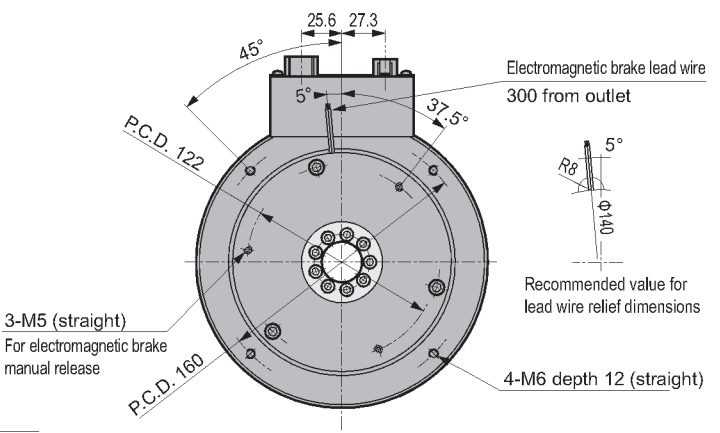
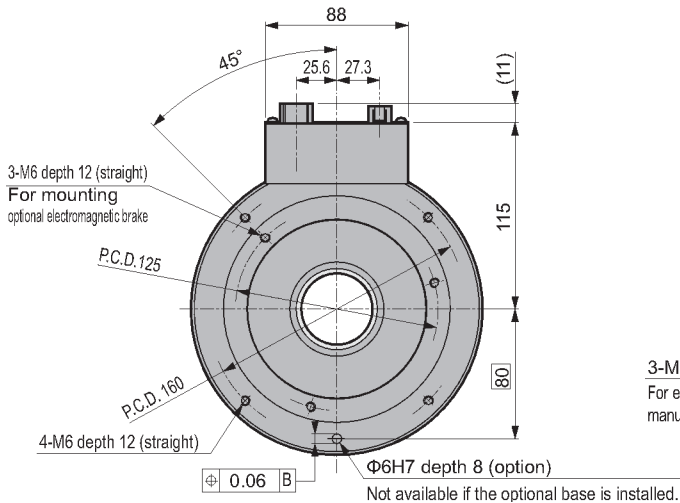
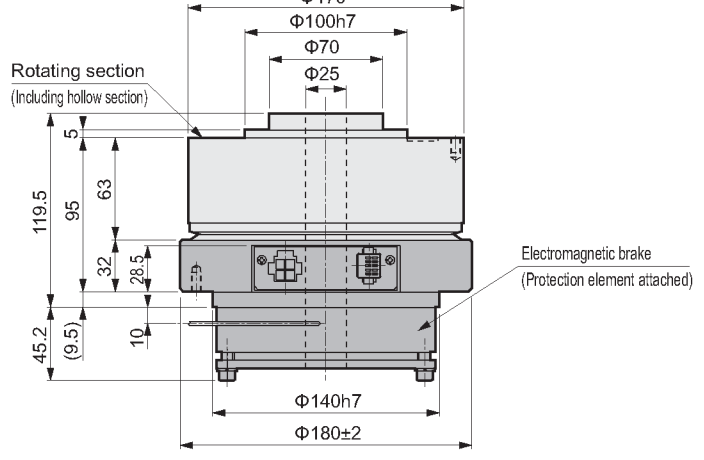
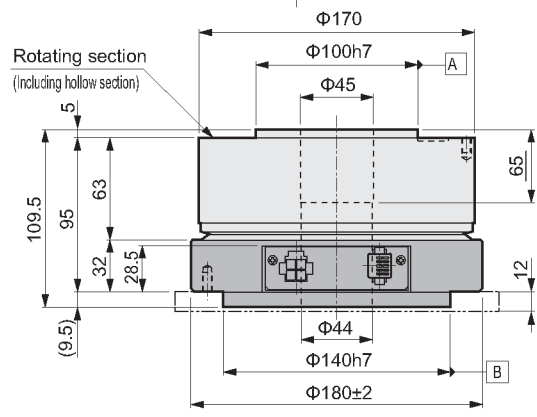
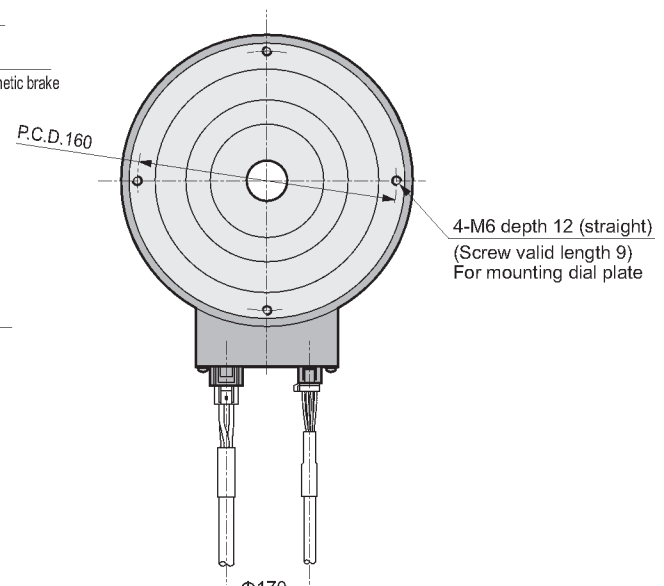
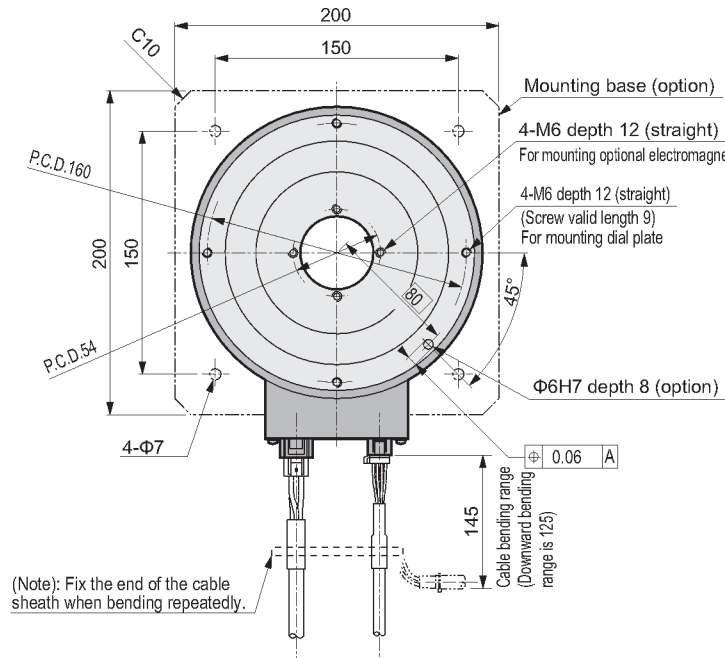

The origin of the actuator may differ from the dimensions shown above.
Origin can be configured randomly using the origin offset function.

Dimensions and technical information are subject to change without notice.

DX45/DX45B

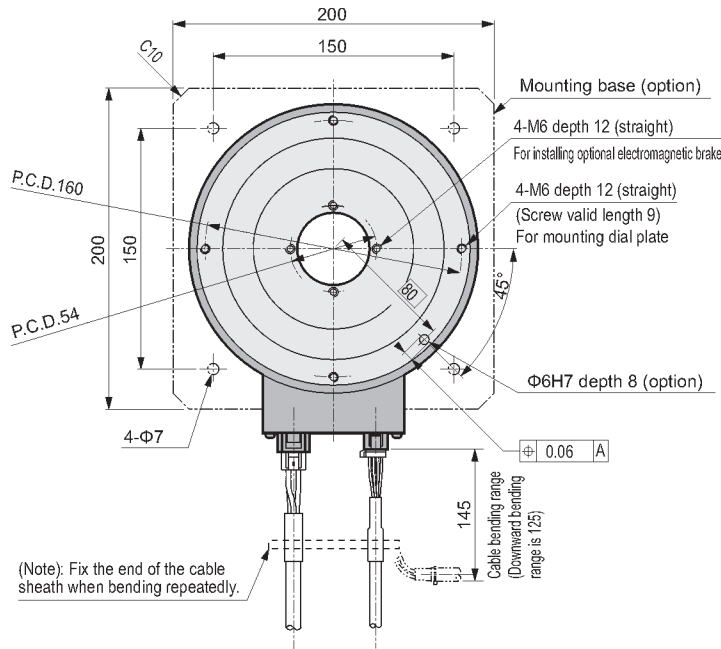

DX45-BR (optional)

With electromagnetic brake
Refer to the left drawings for options.

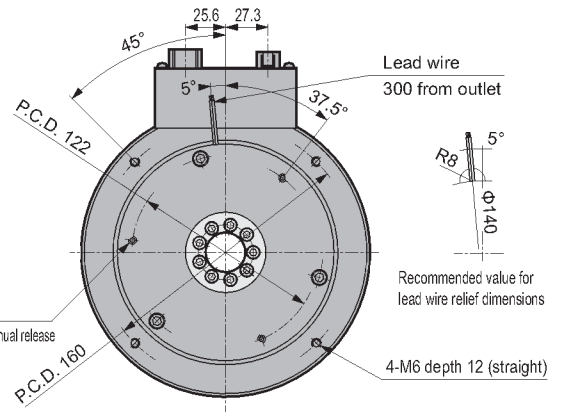
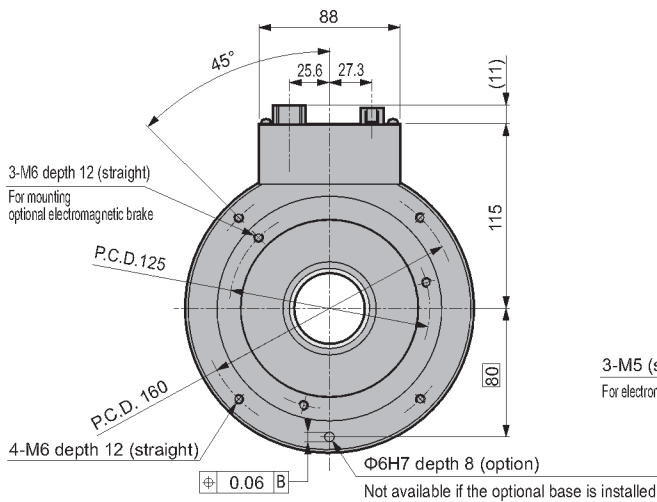
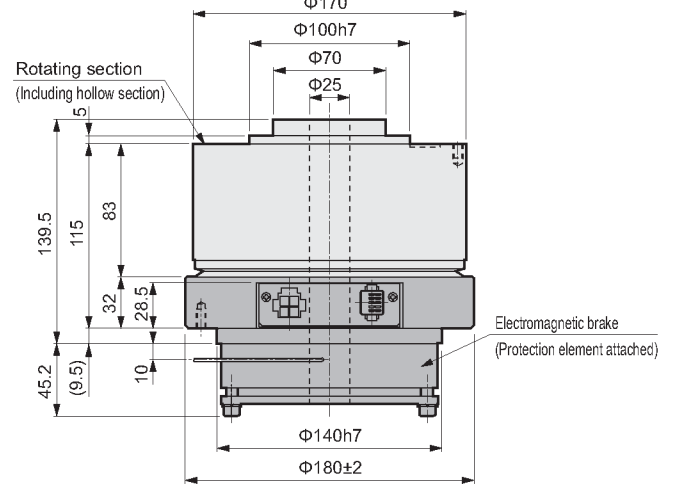
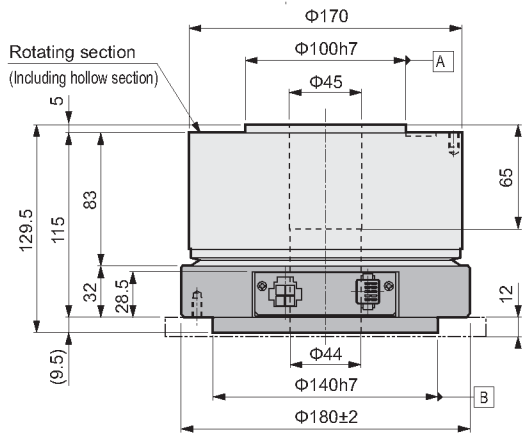
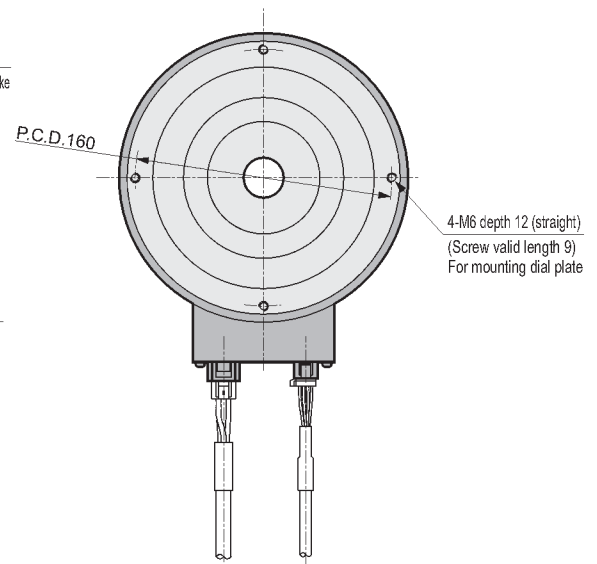

The origin of the actuator may differ from the dimensions shown above.
Origin can be configured randomly using the origin offset function.

Dimensions and technical information are subject to change without notice.

DX Series Dimensions

DX75/DX75B

DX75-BR (optional)

With electromagnetic brake
Refer to the left drawings for options.

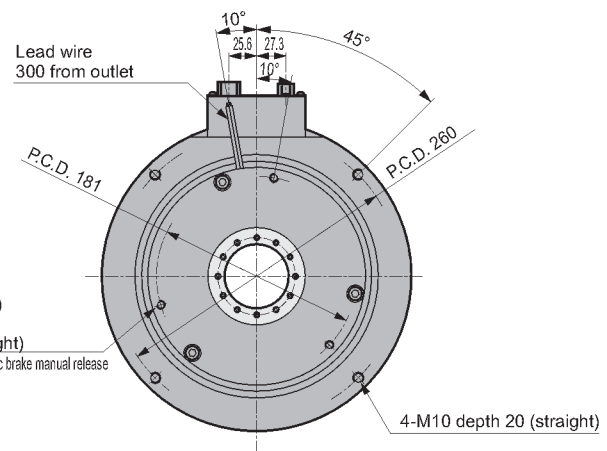
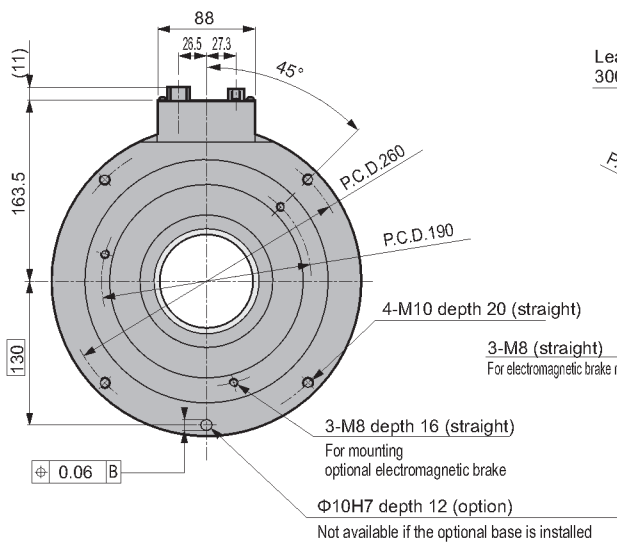
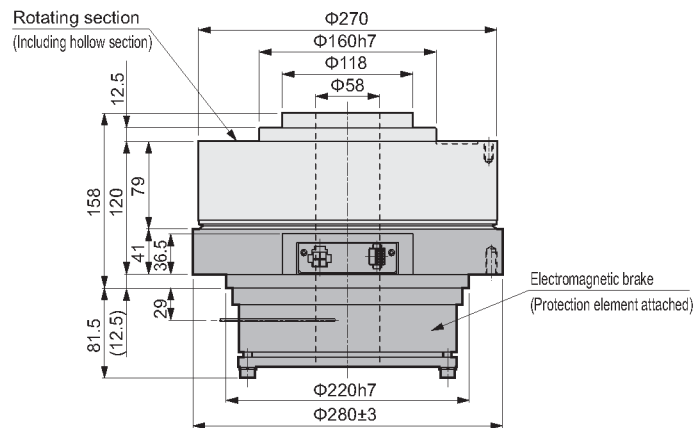
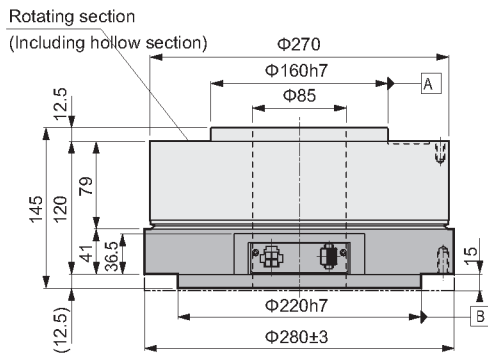
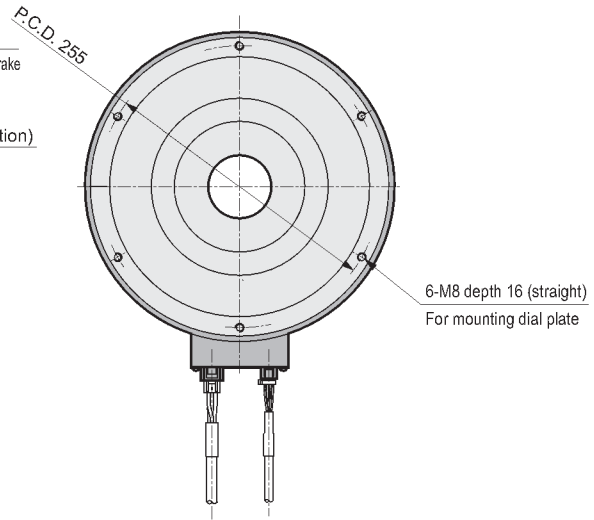
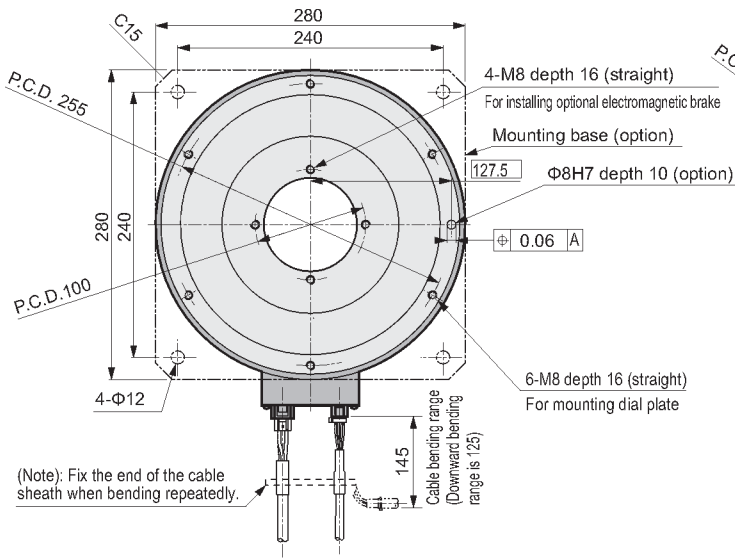

The origin of the actuator may differ from the dimensions shown above.
Origin can be configured randomly using the origin offset function.

Dimensions and technical information are subject to change without notice.

DX Series Technical Specifications

DX150

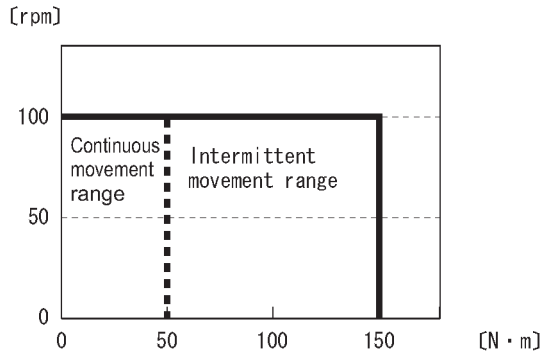

*This graph shows the characteristics under 3 phase AC200V

DX300

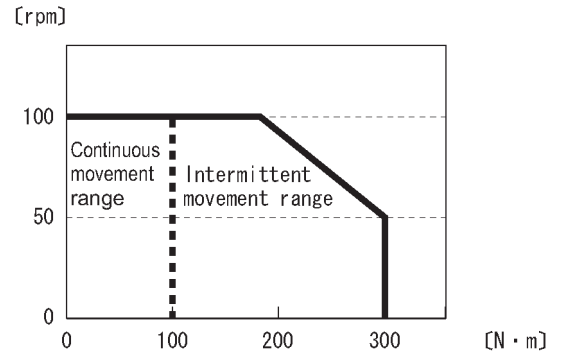

*This graph shows the characteristics under 3 phase AC200V

DX500

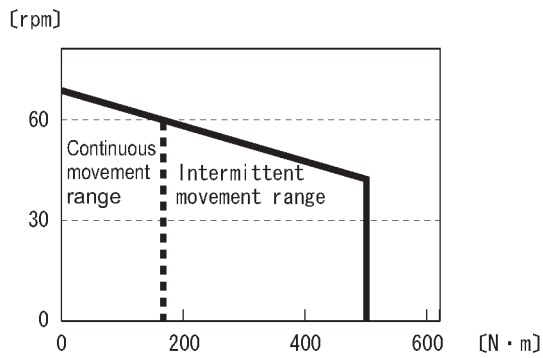

*This graph shows the characteristics under 3 phase AC200V

(Note) moment load

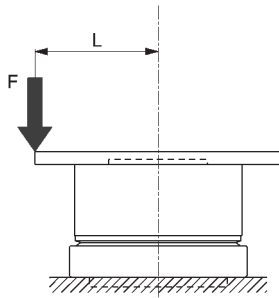

(Fig. a)

$$M(N\cdot m) = F(N) \times L(m)$$

M: Moment load

F: Load

L: Distance from output shaft center

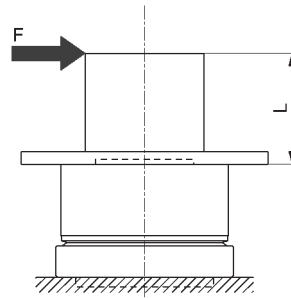

(Fig. b)

$$M(N\cdot m) = F(N) \times (L + 0.02)(m)$$

M: Moment load

F: Load

L: Distance from output shaft flange

Dimensions and technical information are subject to change without notice.

DX Series Dimensions

DX150/DX150B

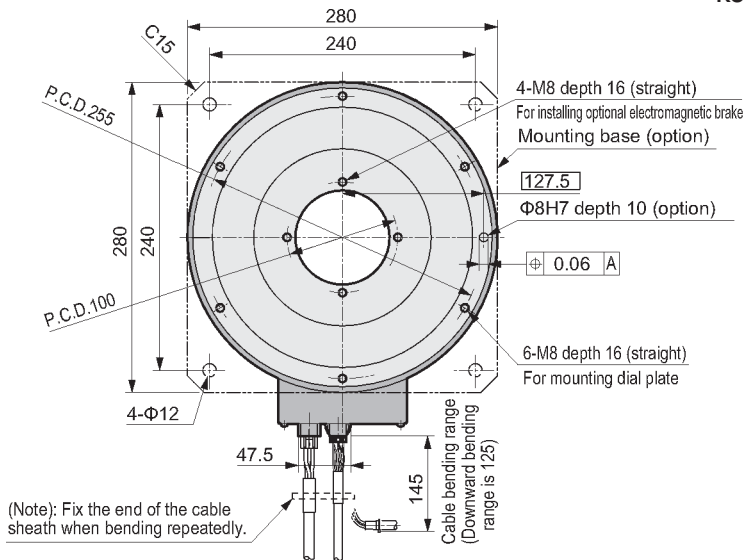

DX150-BR (optional)

With electromagnetic brake
Refer to the left drawings for options.

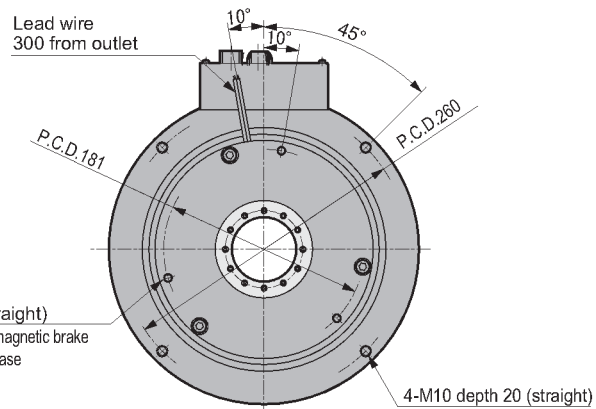
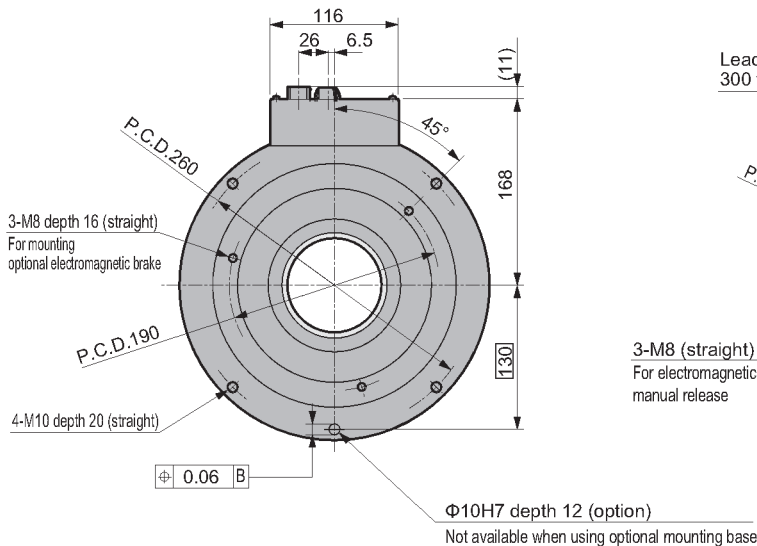
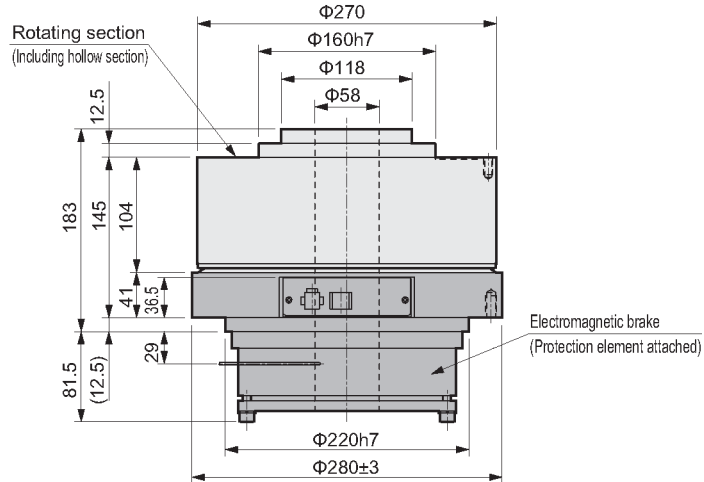
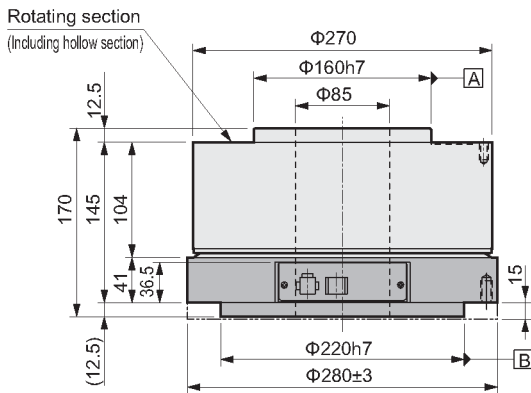
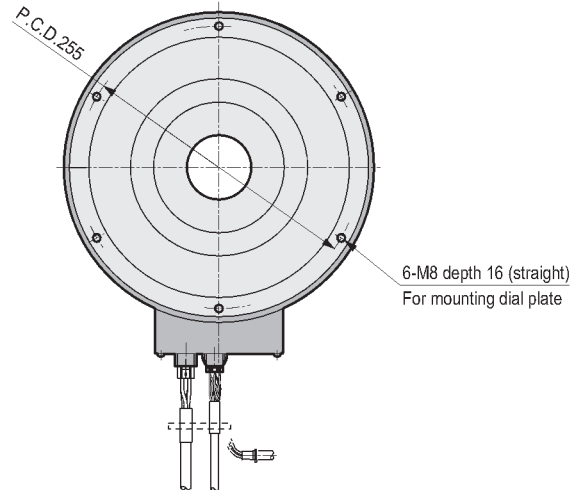

The origin of the actuator may differ from the dimensions shown above.
Origin can be configured randomly using the origin offset function.

Dimensions and technical information are subject to change without notice.

DX Series Dimensions

DX300/DX300B

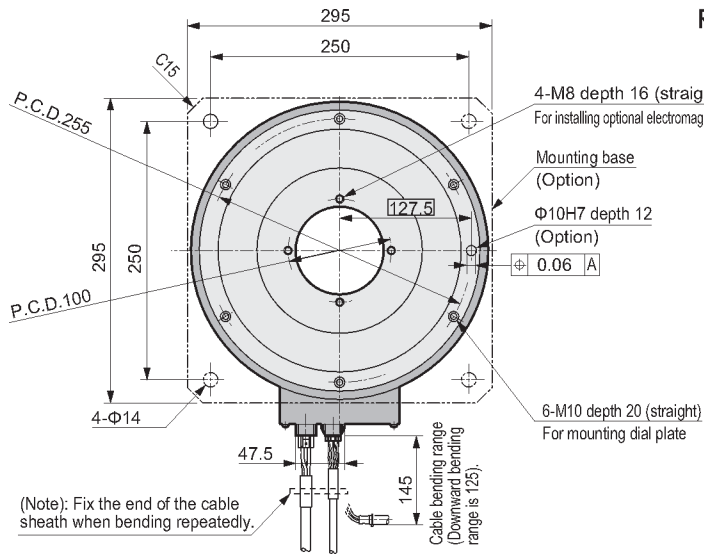

DX300-BR (optional)

With electromagnetic brake
Refer to the left drawings for options.

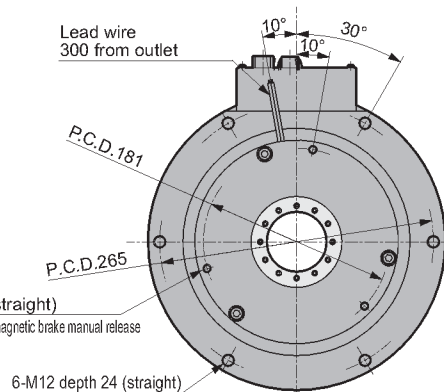
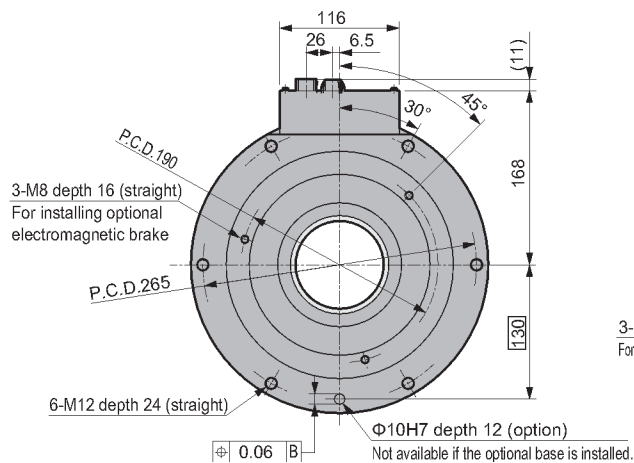
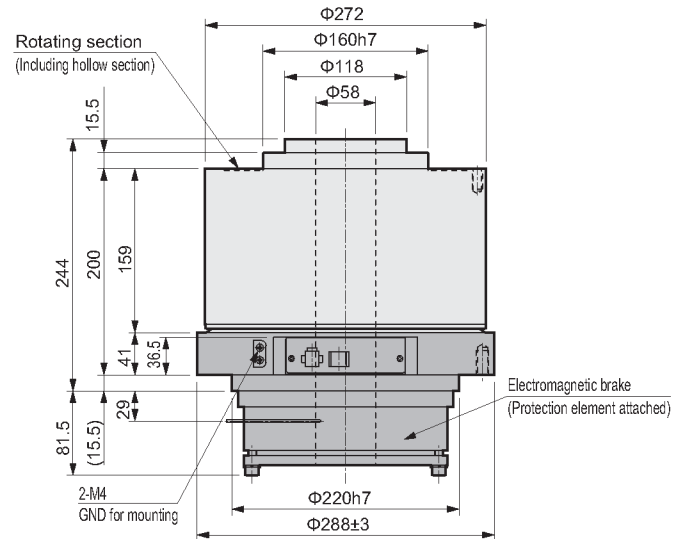
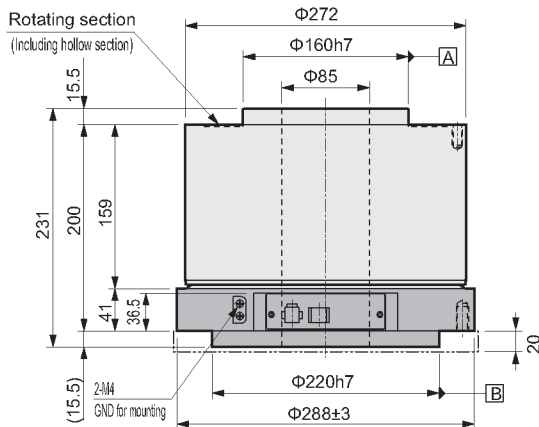
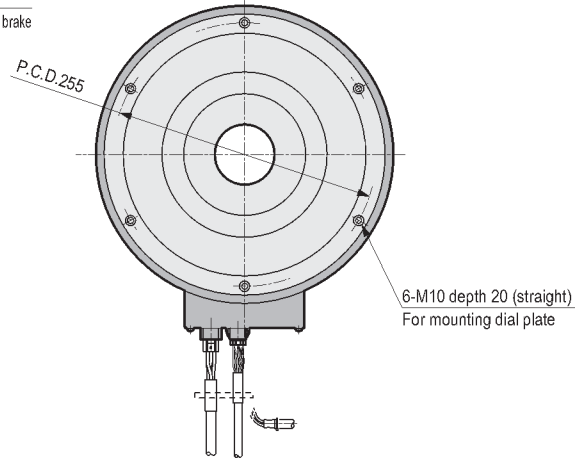

The origin of the actuator may differ from the dimensions shown above.
Origin can be configured randomly using the origin offset function.

Dimensions and technical information are subject to change without notice.

DX Series Dimensions

DX500/DX500B

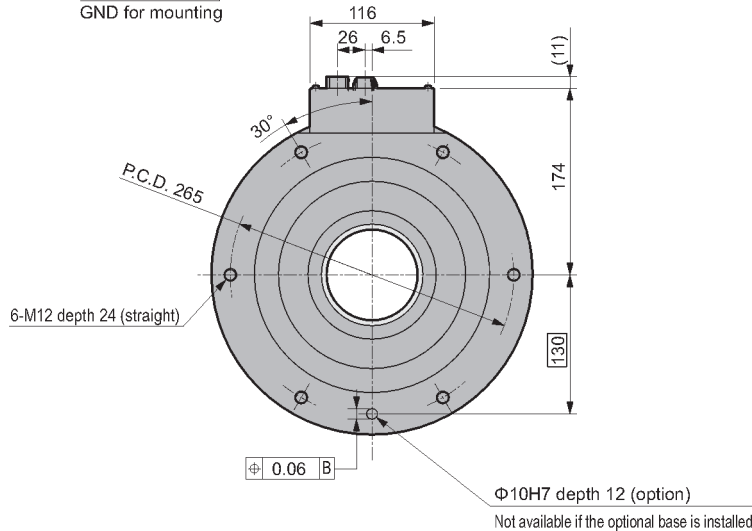
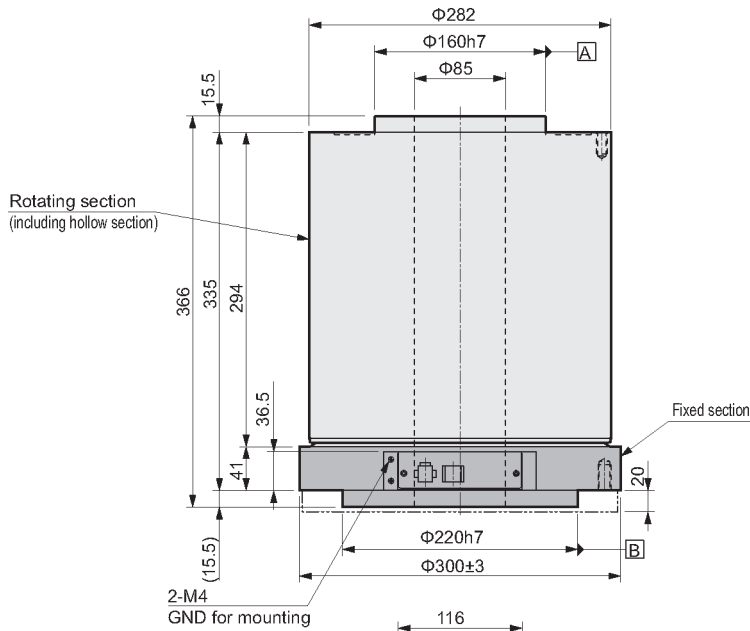
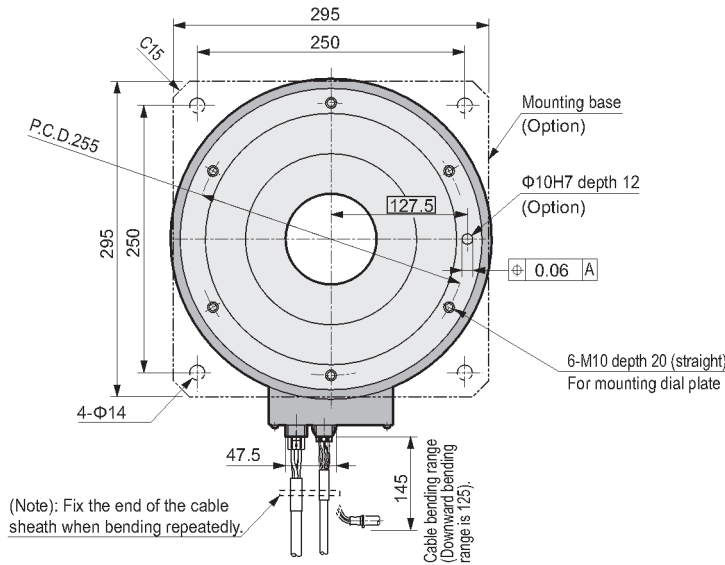

The origin of the actuator may differ from the dimensions shown above. Origin can be configured randomly using the origin offset function.

Dimensions and technical information are subject to change without notice.



DXS/DXH Type Driver



Features

- Separated main and control power supply
- Wiring methods changed from terminal block to connector
- Compact and light weight (resin body)
- 7 segment 2-digit LED display
- Encoder output added (only for parallel I/O)
- Optional serial communication (circuit board integrated)
- Monitor for positioning information and alarm condition. (Only CCL, PRO, DVN option)

Common specifications

Descriptions		Model	
		DXS	DXH
Power voltage	Main power supply	Three phase 200V±10% to AC230 VAC ±10% (Note 1) Single phase 200V±10% to AC230 VAC ±10% (Option J1) (Note2, 3)	
	Control power supply	Single phase 100V±10% to 120 VAC ±10% Single phase 200V±10% to 230 VAC ±10% (Option J1) (Note2, 3)	
Power supply frequency		50/60 Hz	
Rated input current		AC200V: 1.8A AC100V: 2.4A	AC200V: 5.0A
Rated output current		1.9A	5.0A
Structure		Driver and controller integrated type (open frame)	
Ambient temperature range		0 to 50°C	
Ambient humidity range		20 to 90%RH (with no dew condensation)	
Storage ambient temp. range		-20 to 80°C	
Storage ambient humidity range		20 to 90%RH (with no dew condensation)	
Atmosphere		With no corrosive gas and powder dust	
Noise-resistance		1000V(P-P), pulse amplitude 1 sec, start up 1nsec EMI test inductive noise (capacity coupling)	
Vibration resistance		4.9m/s ²	
Weight		1.6k g	2.1k g
Protection		IP2X(excluding CN4,CN5)	

Note 1: Single phase 200 to 230 VAC is available for models with a torque of 45Nm or less.
 Note 2: Connecting 200 to 230 VAC to 100 to 115VAC specifications (option -J1) will destroy the driver.
 Note 3: (-J1) cannot be selected for models with a max. torque of 75Nm or more.
 Note 4: If the power has been cut off while the actuator is rotating, the rotation may continue due to inertia.
 Note 5: In some cases, the actuator will move due to the remaining electricity in the drive, even after the power has been cut off.

Performance specifications

Descriptions	Specification
Number of control axis	1 shaft and 540672 pulse/1 rotation
Angle input increment	° (degree), pulse, index number
Min. angle setting unit	0.001° and 1 pulse
Speed input increment	seconds, rpm
Speed setting range	0.01 to 100 second/0.01 to 300rpm (Note 1)
Equal index number	1 to 255
Max. command value	7-digits input ±9999999
Time	0.01 to 99.99 sec.
Programming language	NC language
Programming method	Data can be set with an Teaching Pendant or personal computer, etc., using the RS-232-C port.
Operation mode	Automatic, MDI, jog, single block, servo OFF, pulse string input mode
Coordinates	Absolute, incremental
Acceleration curve	<5 type> Modified sine (MS), modified constant velocity (MC MC2), modified trapezoidal (MT), Trapecloid (TR)
Status display	LED power display
Operating indication	7-segments LED display (2 digit)
Comm. interface	RS-232C compliant
I/O signal	Refer to page of each interface specifications.
Program capacity	Approx. 6000 character (256 programs)
Electronic thermal	Overheat protection of actuator

Note 1) max. rotation speed differs depending on the actuator to be connected.

Power supply wattage and breaker capacity

DXS type driver

Power supply wattage (KVA)		Rush current (A)		Breaker capacity
Max.	Rated	Single phase 100V	Single phase/three phase 200V	Rated current (A)
0.8	0.5	16(Note1)	56(Note1)	10
1.0	0.5			
1.5	0.5			
2.0	0.8	—		

Note 1) Rush current value is typical value in AC115V and AC230V.

DXH type driver

Power supply wattage (KVA)		Rush current (A)	Breaker capacity
Max.	Rated	Three phase 200V	Rated current (A)
3.0	0.8	56(Note1)	20
4.0	1.5		
4.0	2.0		
4.0	2.0		

Note 1) Rush current value is typical value in AC230V.

Dimensions and technical information are subject to change without notice.



Dimensions

DXS type driver

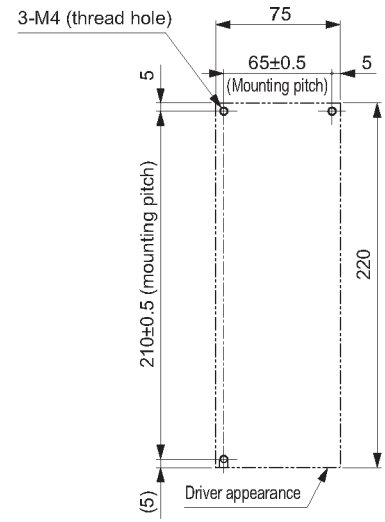
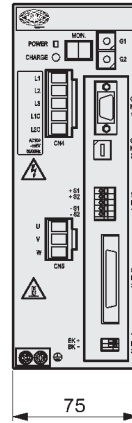
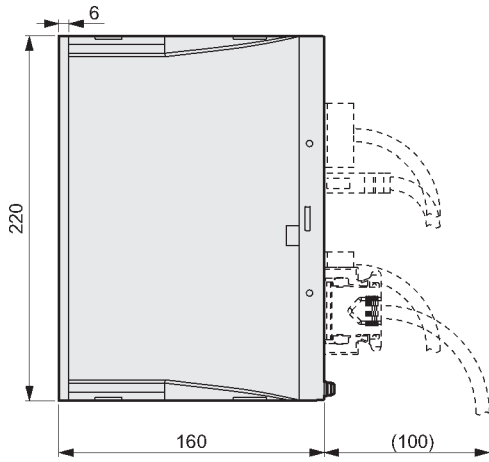

Installation hole machining drawing (Note 1)

DXH type driver

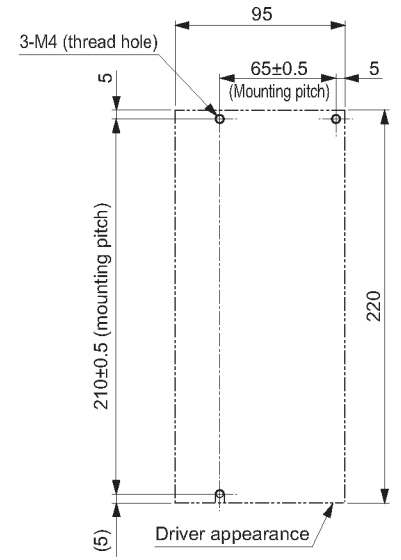
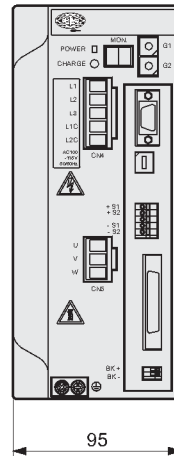
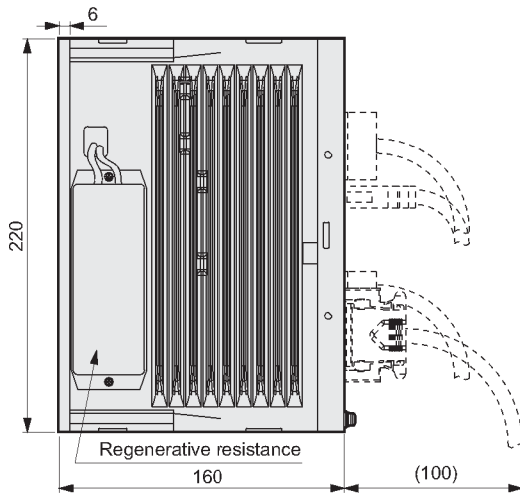

Installation hole machining drawing (Note 1)

Dimensions and technical information are subject to change without notice.



DXTP Teaching Pendant



Features:

- (1) Easy programming- Equal index programs are created easily by answering questions interactively with the dialog terminal.
- (2) No dedicated power supply required. Power is supplied from the teaching pendant.
- (3) Programs and parameters can be stored, and programs can be copied.

Descriptions	DXTP
Operation mode	Edit, display, parameter, operation or copy
Program capacity	Equal index or NC program 2000 character (1 program)
Program No.	Equal index program: program No. 0 to 999
Indicator	16 character x 2 line (LCD display)
Input key	17key (Emergency stop key: 1, control key: 5 characters, numerals key: 11)
Back up	Super capacitor (approx. 3 hours)
Power supply	Supply from direct drive actuator driver
Cable length	2m
Ambient temperature range	0 to 50°C
Ambient humidity range	20 to 90% (with no dew condensation)
Conservation ambient temperature range	-20 to 80°C
Conservation ambient humidity range	20 to 90% (with no dew condensation)
Atmosphere	With no corrosive gas and powder dust
Weight	140g (does not include weight of cable)

DXTP Dimensions

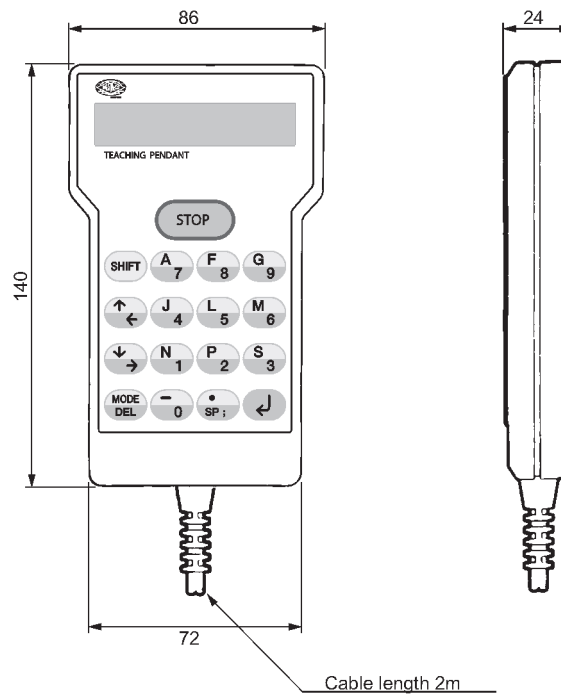

Dimensions and technical information are subject to change without notice.

DXTP Teaching Pendant

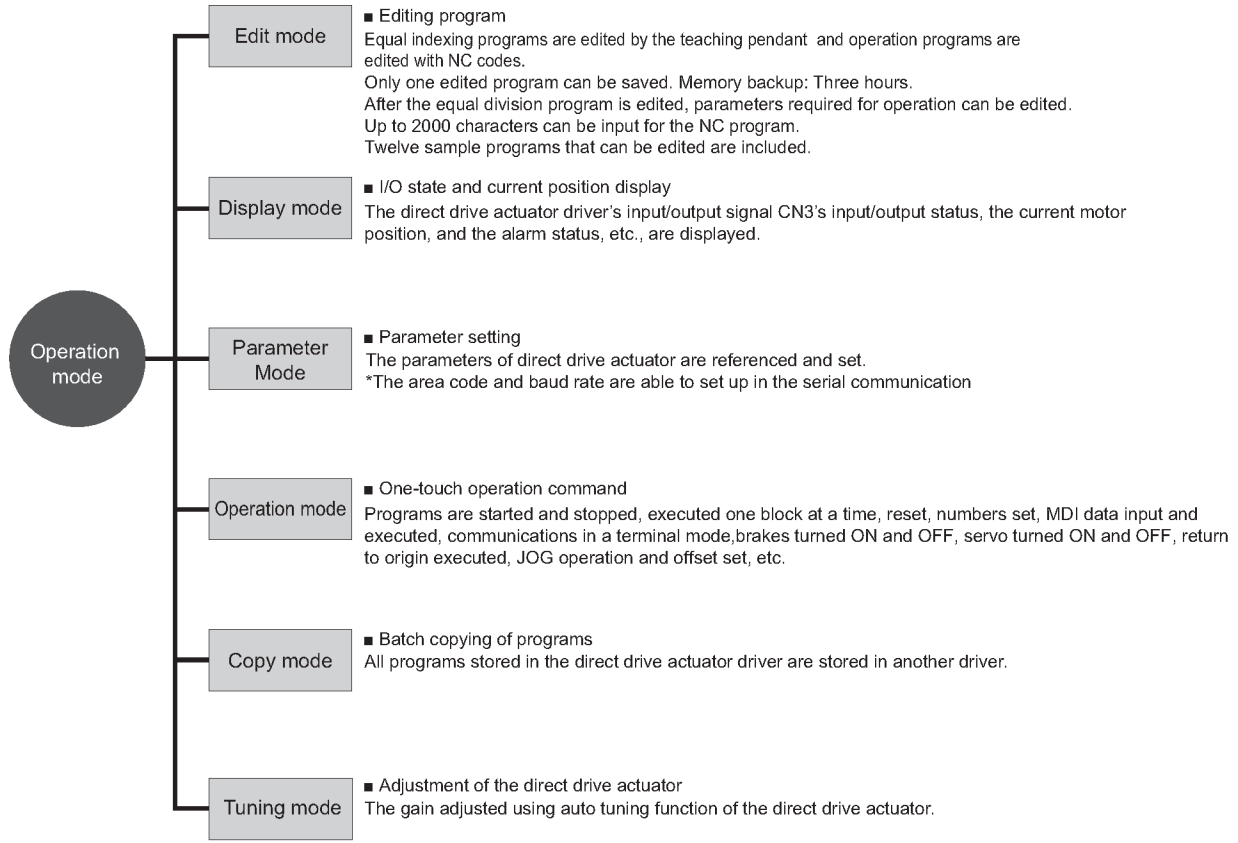

Interactive Programming

Programs are created easily by inputting the following settings:

[Example of program input]

Create program	Program No. (0 to 999)
Return-to-origin position	1. Origin 2. Index
Return direction	1. CW 2. CCW
Return speed	(1.0 to 20.0) rpm
Index number	(1 to 255)
Moving time	[0.01 to 100] second
Rotational direction	1. CW 2. CCW
Stop process	1. Start waiting 2. Dwell
Brake	1. Used 2. Vacant
Delay timer	[0.01 to 99.99] second
M code	1. M code 2. Index position

Examples of Use

Try operating the direct-drive actuator.	⇒	Edit mode	Twelve types of sample programs are selectable, so try these during adjustment.
Create a program and store it in the direct drive actuator.	⇒	Edit mode	Programs are input and stored in easy steps.
Start a program stored in the direct drive actuator.	⇒	Operation mode	Programs are started easily by designating the program number.
Use features of each cam curves.	⇒	Parameter mode	Five types of cam curves are selectable. Drives that use features of each type are realized in one-touch operation.
Confirm a I/O on/off.	⇒	Display mode	The condition of I/O can display.

Dimensions and technical information are subject to change without notice.



RGD/RDS Series Roller Gear Index Drives

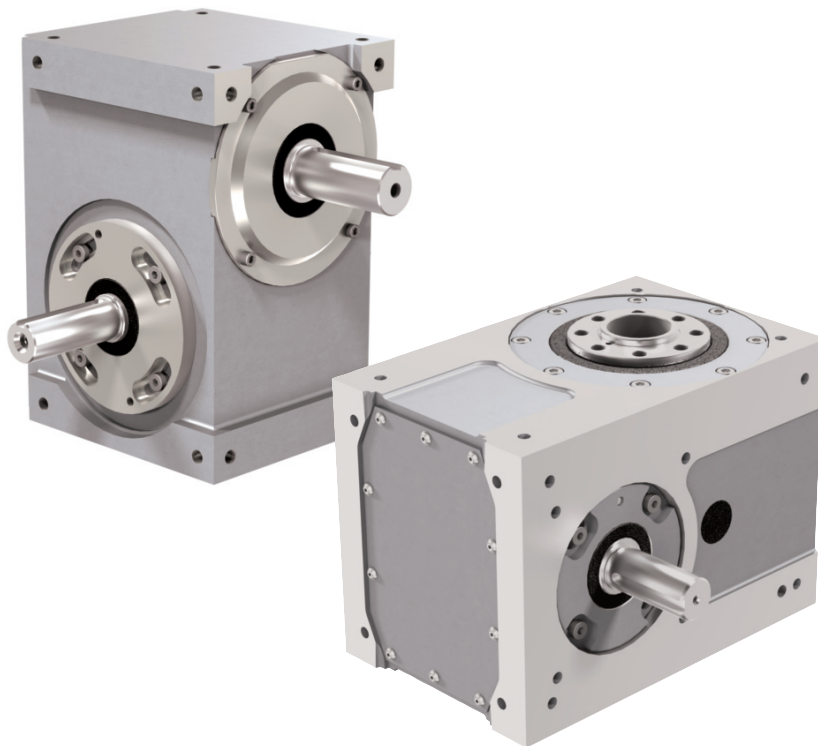

Features:

The **CAMCO Roller Gear Index Drives** are robust, versatile units suitable for a wide variety of applications.

- Available with a flange (RGD) or shaft (RGS) output
- All six surfaces are machined for universal mounting
- Optional center thru-hole in flange version facilitates passage of electrical wiring, pneumatic lines or mechanical linkages
- Short camshaft motion periods, due to oversized cam design, are well suited for continuous running applications or for special motion requirements such as oscillating motions

Table of Contents

How to Order	118
40RGD/40RGS	120
50RGD/50RGS	122
70RGD/70RGS	124
80RGD/80RGS	126
110RGD/110RGS	128
350RGD/350RGS	130
500RGD/500RGS	132
600RGD/600RGS	134

Dimensions and technical information are subject to change without notice.



RGD/RDS Series How to Order

Indexer Ordering Procedure

1. Model
 2. Input Shaft Configuration
 - Side 1
 - Side 2
 - Double Input – DI (Standard)
 3. Cam Lead (Helix)
 - Right Hand (Standard)
 - Left Hand
- NOTE: Input may rotate in either direction to achieve desired direction of output rotation.
4. Indexer Mounting Position: 1-6
 5. Indexer Housing Mounting Holes: Side 1-6 (more than one side can be selected)

Reducer Ordering Procedure

1. Model
2. Ratio
 - 10:1, 15:1, 20:1, 25:1, 30:1, 40:1, 50:1, 60:1
3. Motor Adapter
4. Reducer Input Shaft Extension
 - Single Input (SE) or Double Input (DE)
5. Mounting
 - Mounting Position A, B, C, or D
 - Mounted on Indexer Side 1 or Side 2
6. Input Shaft Orientation
 - Left or Right (See Diagram Below)

Input Shaft Configuration (Top View)

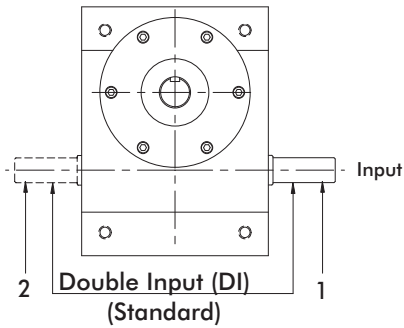

Input Shaft Rotation

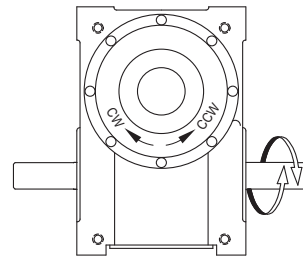

Relative Rotation for Right Hand Cam:

- CW Input Side 1 CCW Output
- CCW Input Side 2 CW Output

NOTE: Input can be driven in either direction

Indexer Housing Mounting Holes

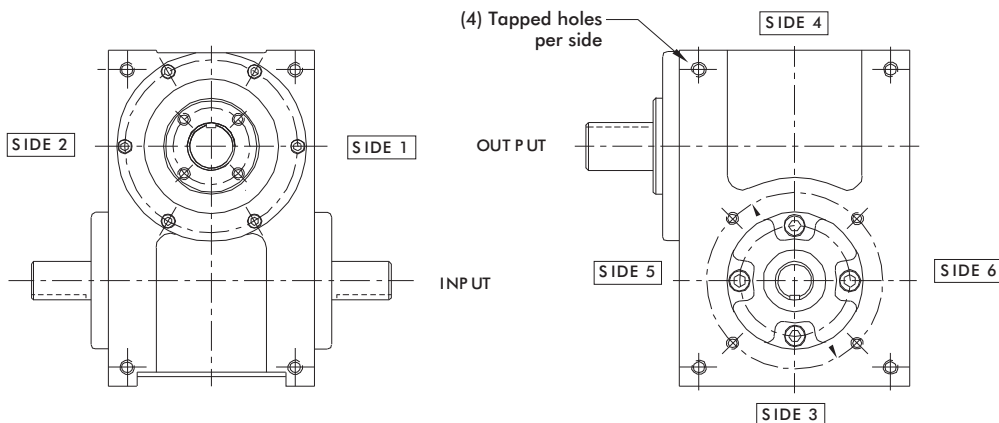

Dimensions and technical information are subject to change without notice.



Indexer Mounting Position

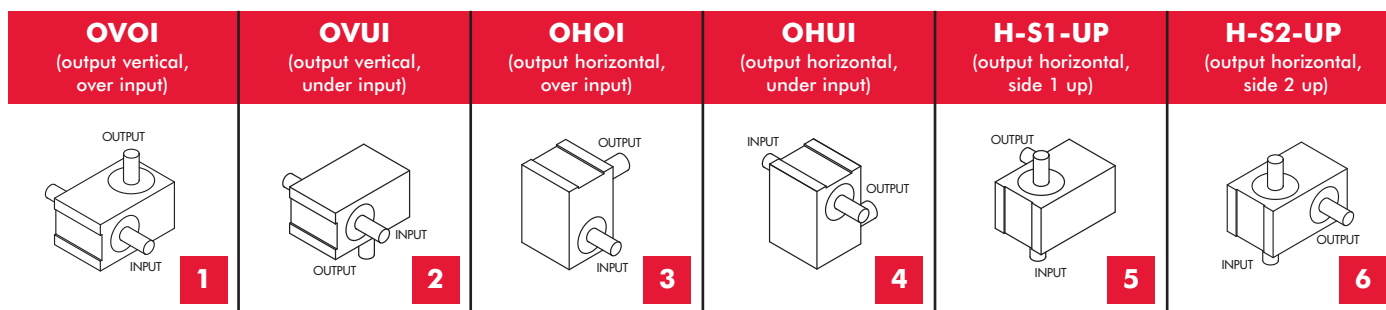

Gear Reducer Mounting Positions (Figure 4)

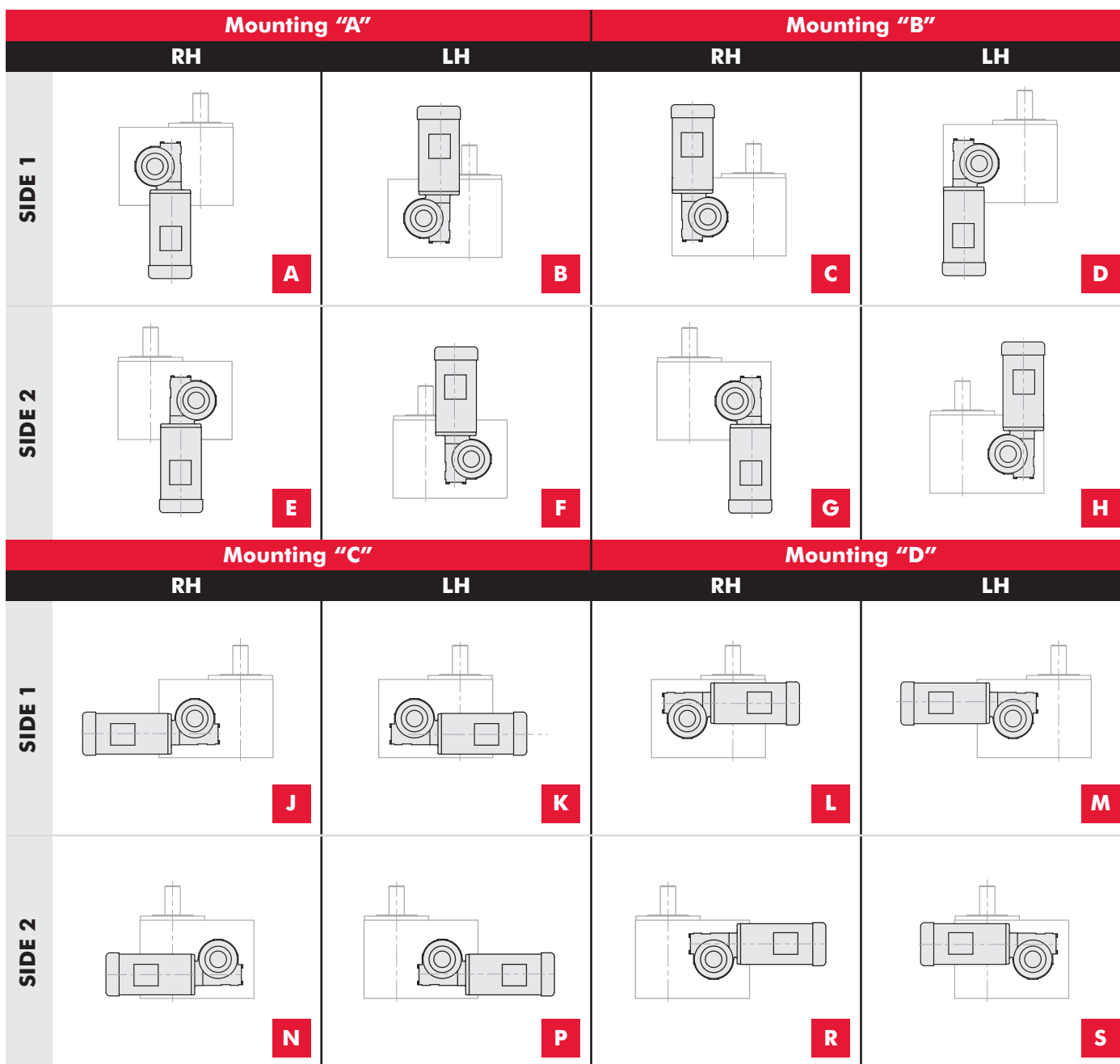

Dimensions and technical information are subject to change without notice.

40RGD/40RGS Product Overview, Technical Information

40RGD

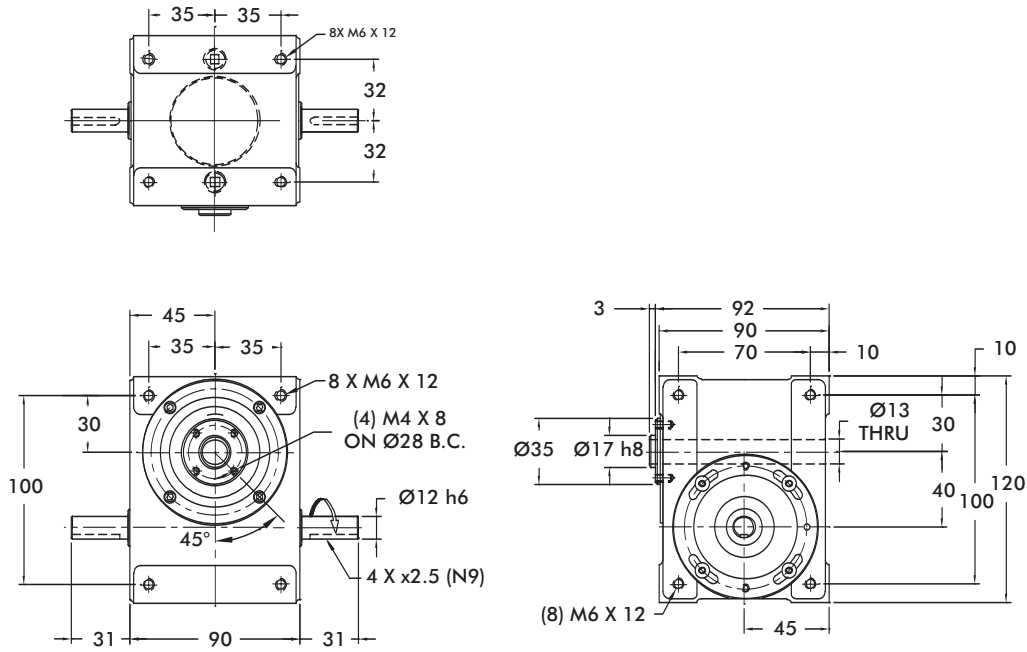

40RGS

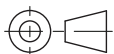
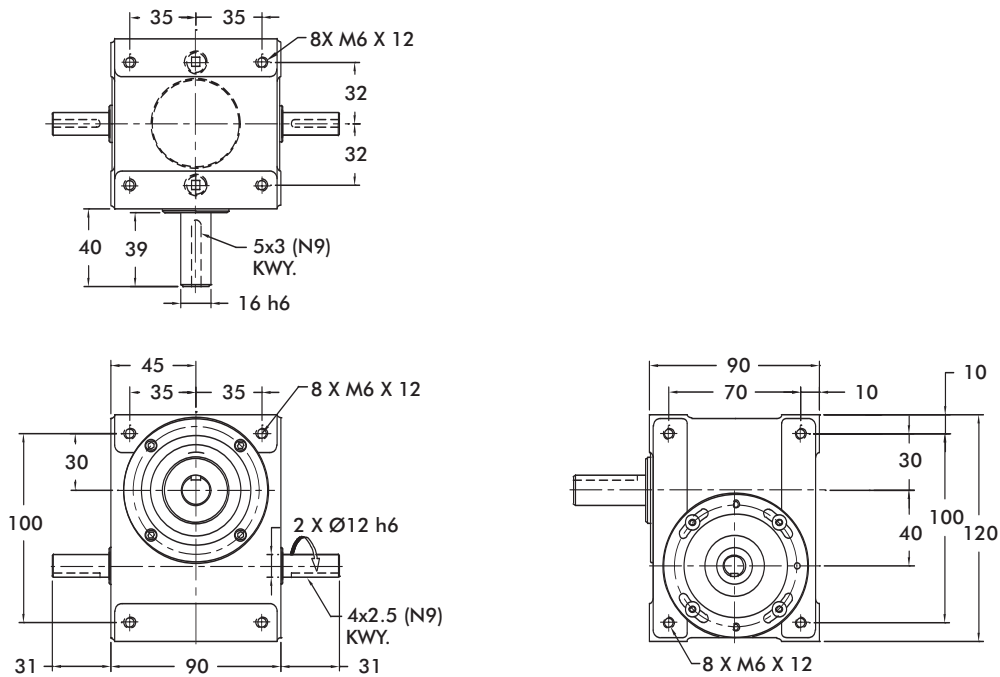

Unless otherwise noted, all dimensions are in mm.

Dimensions and technical information are subject to change without notice.



40RGD/40RGS Product Overview, Technical Information

40RGD/40RGS Indexer Capacities						
Stops	Index Period	Motion	B ₁₀ Capacity at 50 RPM (in-lb)	RGD Internal Inertia (lb-in ²)	RGS Internal Inertia (lb-in ²)	Model
2	270	ms	150	0.3	0.4	40RG(D/S)2H12-270
3	270	ms	187	0.3	0.4	40RG(D/S)3H12-270
4	270	ms	214	0.4	0.4	40RG(D/S)4H12-270
	180	ms	225	0.4	0.4	40RG(D/S)4H12-180
6	270	ms	193	0.3	0.4	40RG(D/S)6H12-270
	90	ms	216	0.3	0.4	40RG(D/S)6H12-90
8	270	ms	216	0.4	0.4	40RG(D/S)8H12-270
	90	ms	249	0.4	0.4	40RG(D/S)8H12-90
12	270	ms	124	0.3	0.4	40RG(D/S)12H9-270
	90	ms	139	0.3	0.4	40RG(D/S)12H9-90
16	270	ms	254	0.4	0.4	40RG(D/S)16H12-270 II
	120	ms	312	0.4	0.4	40RG(D/S)16H12-120 II
24	180	ms	173	0.3	0.4	40RG(D/S)24H9-180 II
	120	ms	326	0.3	0.4	40RG(D/S)24H12-120 III

Other Motions (stops and index periods) available. Contact your DE-STA-CO sales representative for more information.

Features

- Fully Metric
- Universal Mounting: mounting holes on any of 6 sides
- Center Through Hole (.50 in./13 mm Diameter) in RGD model.
- Right Hand Cam

Output Load Capacity (loads carried during index):

	RGD	RGS
Radial	1,107 lbs	206 lbs
Thrust/Axial	791 lbs	492 lbs
Moment	762 in-lb	405 in-lb

- **Accuracy** ±90 arcsec / ±.0013" at 3" Radius
- **Repeatability** ±22 arcsec / ±.0003" at 3" Radius

Optional Accessories

- STM RMI28 Gear Reducer (ratios from 7:1 to 100:1) with
 - IEC56B14 Motor Adapter
 - 1/12 hp AC Motor and Inverter Drive (up to 60 cpm)
- Single or Dual Cycle Cam and Limit Switch
- Left Hand Cam
- Relief in Dwell for shot-pin applications

Dimensions and technical information are subject to change without notice.



50RGD/50RGS Product Overview, Technical Information

50RGD

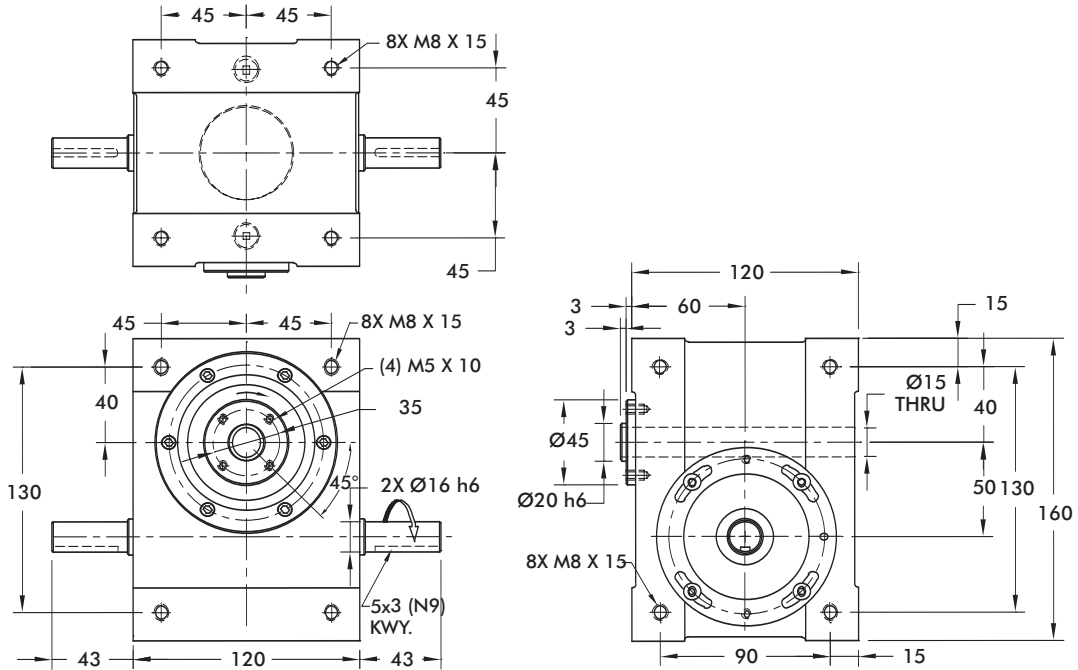

50RGS

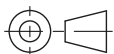
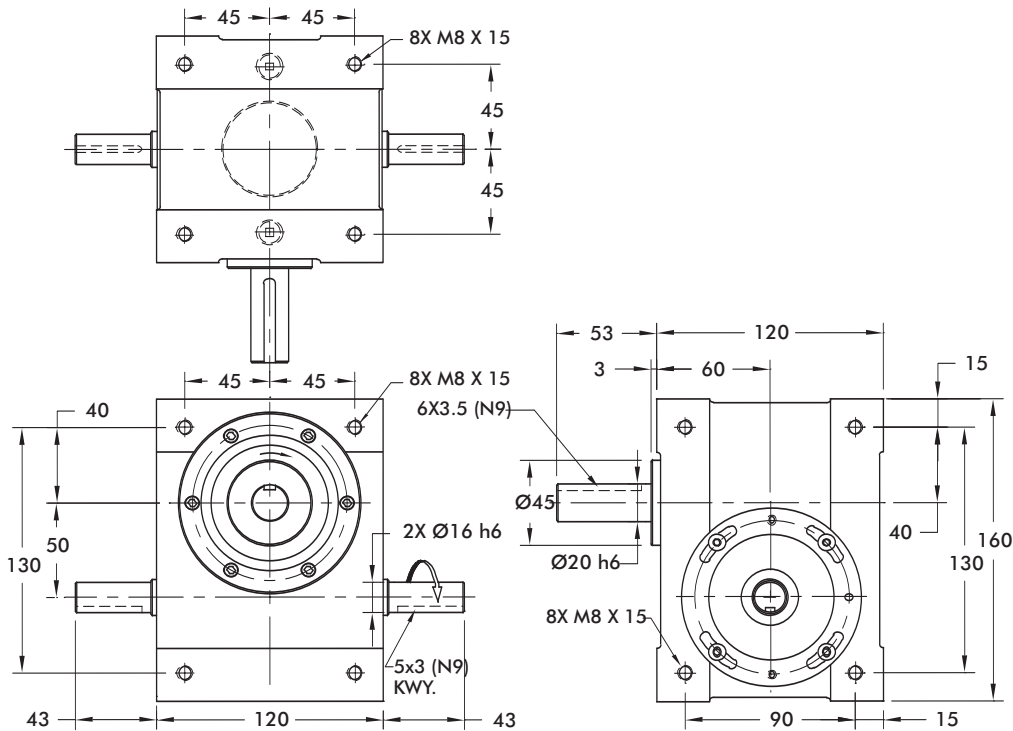

Unless otherwise noted, all dimensions are in mm.

Dimensions and technical information are subject to change without notice.



50RGD/50RGS Product Overview, Technical Information

50RGD/50RGS Indexer Capacities						
Stops	Index Period	Motion	B ₁₀ Capacity at 50 RPM (in-lb)	RGD Internal Inertia (lb-in ²)	RGS Internal Inertia (lb-in ²)	Model
2	270	msc.50	621	1.4	1.6	50RG(D/S)2H18-270
3	270	ms	287	1.3	1.5	50RG(D/S)3H14-270
	180	ms	300	1.3	1.5	50RG(D/S)3H14-180
4	270	ms	326	1.4	1.5	50RG(D/S)4H14-270
	180	ms	351	1.4	1.5	50RG(D/S)4H14-180
6	270	ms	606	1.4	1.6	50RG(D/S)6H18-270
	90	ms	734	1.4	1.6	50RG(D/S)6H18-90
8	270	ms	336	1.4	1.5	50RG(D/S)8H14-270
	90	ms	403	1.4	1.5	50RG(D/S)8H14-90
12	270	ms	275	1.4	1.5	50RG(D/S)12H12-270
	90	ms	329	1.4	1.5	50RG(D/S)12H12-90
16	180	ms	447	1.4	1.5	50RG(D/S)16H14-180 II
24	180	ms	374	1.4	1.5	50RG(D/S)24H12-180 II
	120	ms	409	1.4	1.5	50RG(D/S)24H12-120 II

Other Motions (stops and index periods) available. Contact your DE-STA-CO sales representative for more information.

Features

- Fully Metric
- Universal Mounting: mounting holes on any of 6 sides
- Center Through Hole (.59 in./15 mm Diameter) in RGD model.
- Right Hand Cam

Output Load Capacity (loads carried during index):

	RGD	RGS
Radial	1,775 lbs	379 lbs
Thrust/Axial	925 lbs	545 lbs
Moment	1,572 in-lb	791 in-lb

Accuracy ±73 arcsec / ±.0011" at 3" Radius

Repeatability ±18 arcsec / ±.0003" at 3" Radius

Optional Accessories

- R180 Reducer (Ratios from 15:1 to 60:1)
 - Double Extended Worm Shaft (Input)
 - Worm Shaft Handwheel
- 1/3 hp AC Drive Package with Inverter Duty Motor and IM-pAC AC Drive (up to 60 cpm)
- Cycle Cam and Limit Switch Mounted to Camshaft
- Right Hand Cam
- Universal Mounting Capability

Dimensions and technical information are subject to change without notice.

70RGD/70RGS Product Overview, Technical Information

70RGD

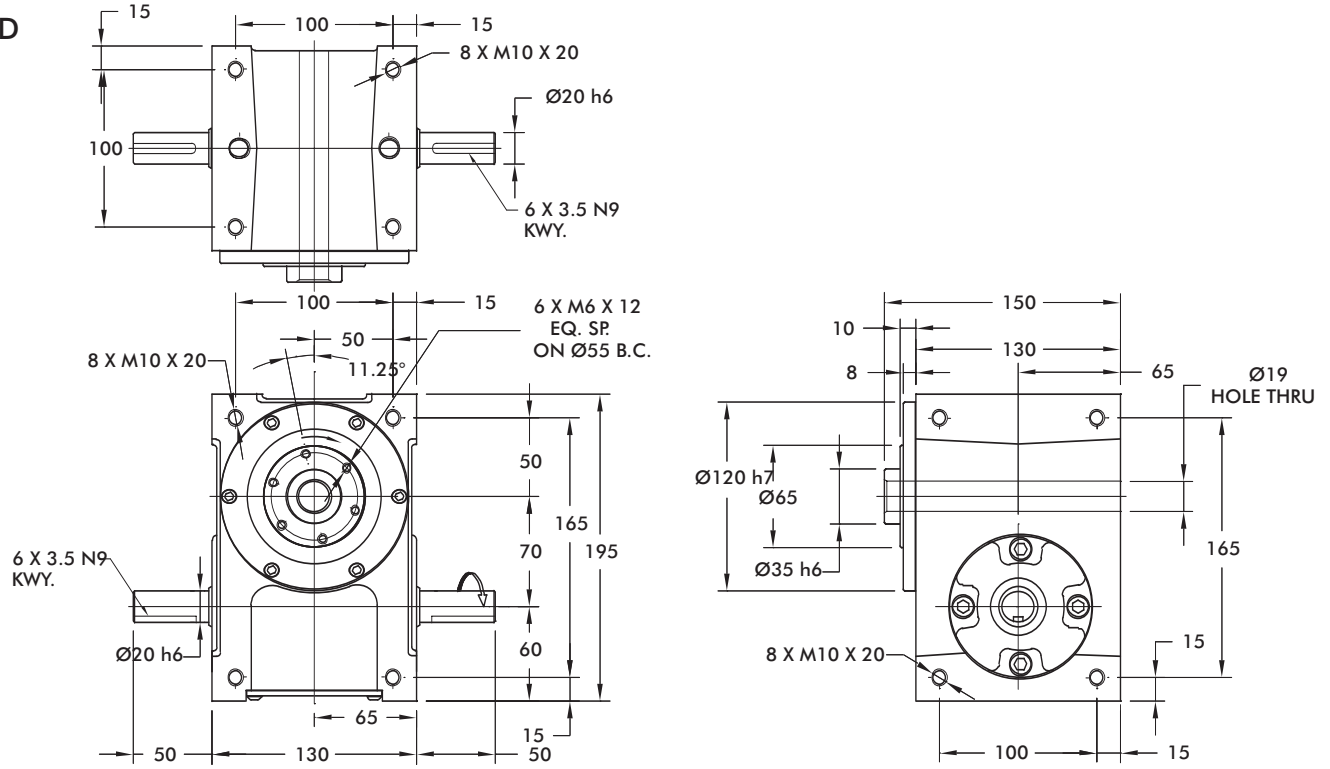

70RGS

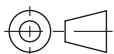
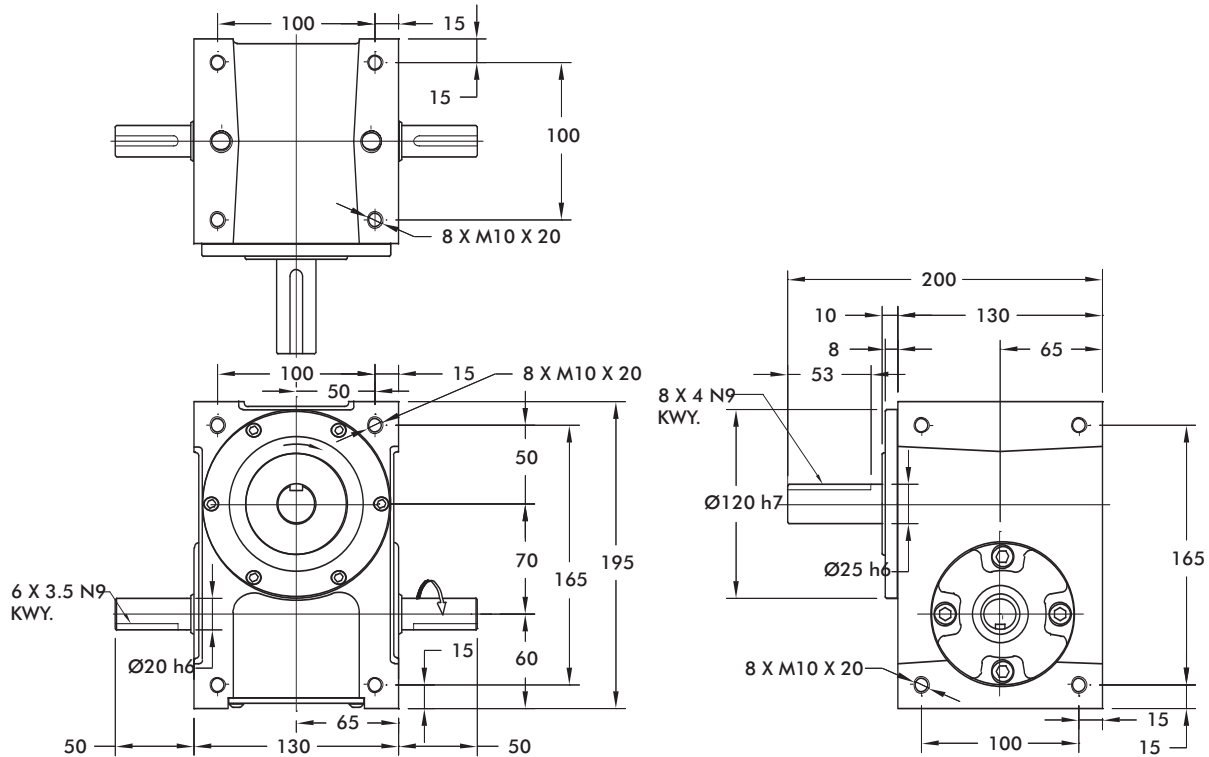

Unless otherwise noted, all dimensions are in mm.

Dimensions and technical information are subject to change without notice.



70RGD/70RGS Product Overview, Technical Information

70RGD/70RGS Indexer Capacities						
Stops	Index Period	Motion	B ₁₀ Capacity at 50 RPM (in-lb)	RGD Internal Inertia (lb-in ²)	RGS Internal Inertia (lb-in ²)	Model
2	270	ms	585	7	8	70RG(D/S)2H20-270
	180	ms	562	7	8	70RG(D/S)2H18-180
3	270	ms	720	7	8	70RG(D/S)3H20-270
	180	ms	753	7	8	70RG(D/S)3H20-180
4	270	ms	821	9	10	70RG(D/S)4H20-270
	120	msc.33	1107	10	10	70RG(D/S)4H18-120
6	270	ms	1406	9	10	70RG(D/S)6H24-270
	90	msc.33	2110	9	10	70RG(D/S)6H24-90
8	270	ms	853	9	10	70RG(D/S)8H20-270
	90	ms	1063	9	10	70RG(D/S)8H20-90
12	270	ms	470	10	10	70RG(D/S)12H14-270
	90	ms	584	10	10	70RG(D/S)12H14-90
24	180	ms	635	10	10	70RG(D/S)24H14-180 II

Other Motions (stops and index periods) available. Contact your DE-STA-CO sales representative for more information.

Features

- Fully Metric
- Universal Mounting: mounting holes on any of 6 sides
- Center Through Hole (.75 in./19 mm Diameter) in RGD model.
- Right Hand Cam

Output Load Capacity (loads carried during index):

	RGD	RGS
Radial	2,833 lbs	560 lbs
Thrust/Axial	2,224 lbs	802 lbs
Moment	3,626 in-lb	1,545 in-lb

Accuracy ±50 arcsec / ±.0008" at 3" Radius

Repeatability ±13 arcsec / ±.0002" at 3" Radius

Optional Accessories

- R180 Reducer (Ratios from 5:1 to 60:1)
- 1/3 hp AC Drive Package with Inverter Duty Motor and Inverter Drive (up to 60 cpm)
- 1/3 hp DC Motor with Varipak DC Motor Control (up to 30 cpm)
- Single or Dual Cycle Cam and Limit Switch
- Left Hand Cam
- Relief in Dwell for shot-pin applications

Dimensions and technical information are subject to change without notice.

80RGD/80RGS Product Overview, Technical Information

80RGD

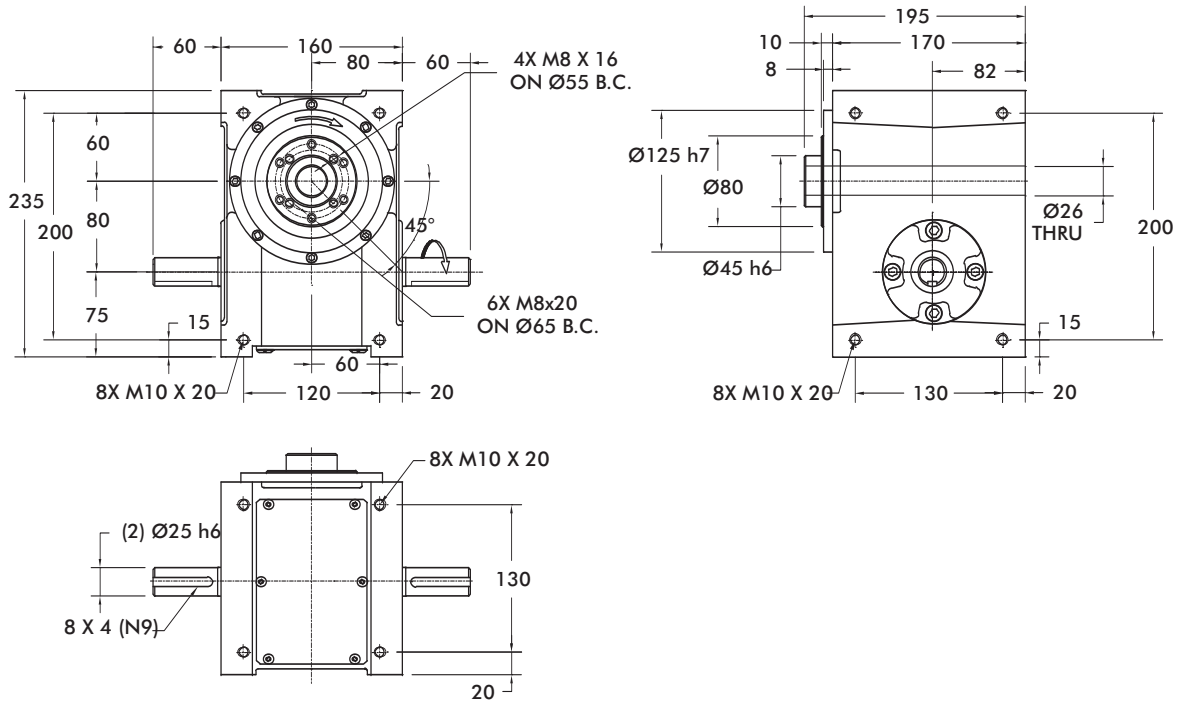

80RGS

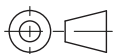
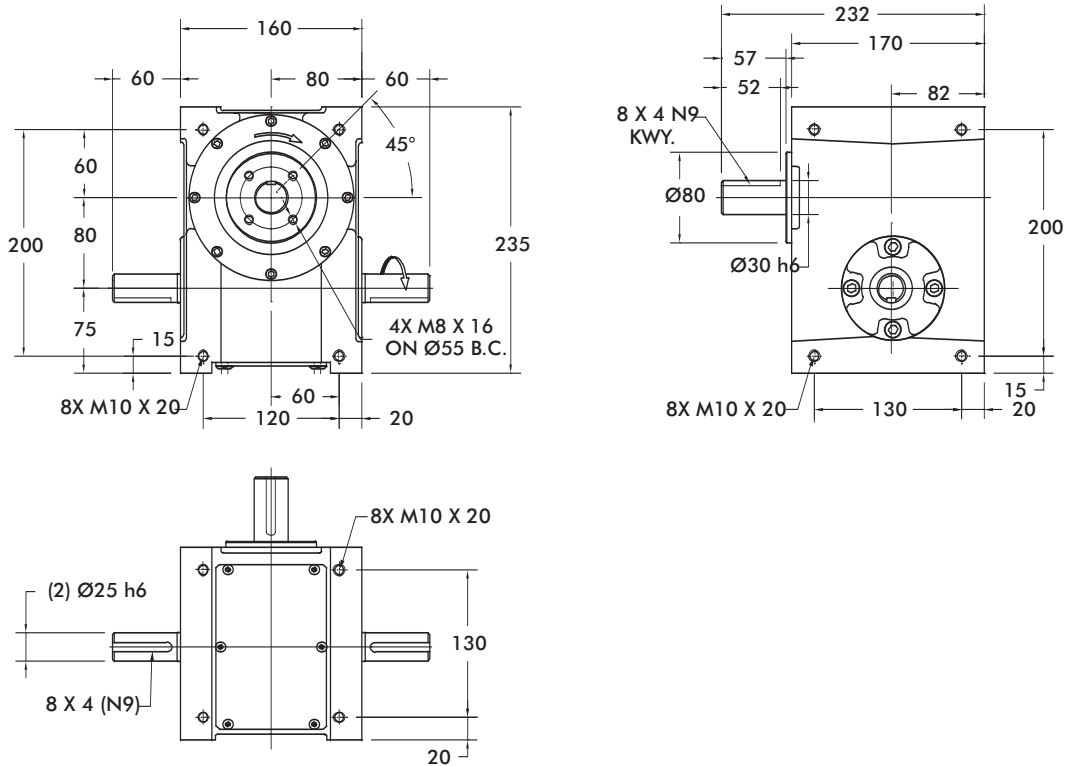

Unless otherwise noted, all dimensions are in mm.

Dimensions and technical information are subject to change without notice.



80RGD/80RGS Product Overview, Technical Information

80RGD/80RGS Indexer Capacities						
Stops	Index Period	Motion	B ₁₀ Capacity at 50 RPM (in-lb)	RGD Internal Inertia (lb-in ²)	RGS Internal Inertia (lb-in ²)	Model
2	330	ms	1144	16	17	80RG(D/S)2H24-330
	270	msc.33	1388	16	17	80RG(D/S)2H24-270
3	270	ms	1422	16	17	80RG(D/S)3H24-270
	180	ms	1513	16	17	80RG(D/S)3H24-180
4	270	ms	1663	21	21	80RG(D/S)4H24-270
	180	msc.33	2377	21	21	80RG(D/S)4H24-180
6	270	ms	1524	18	19	80RG(D/S)6H28-270
	90	msc.50	2323	18	19	80RG(D/S)6H28-90
8	270	ms	1733	21	21	80RG(D/S)8H24-270
	90	msc.33	2937	21	21	80RG(D/S)8H24-90
12	270	ms	1011	20	20	80RG(D/S)12H18-270
	90	msc.60	1725	20	20	80RG(D/S)12H18-90

Other Motions (stops and index periods) available. Contact your DE-STA-CO sales representative for more information.

Features

- Fully Metric
- Universal Mounting: mounting holes on any of 6 sides
- Center Through Hole (1.02 in./26 mm Diameter) in RGD model.
- Right Hand Cam

Output Load Capacity (loads carried during index):

	RGD	RGS
Radial	4,790 lbs	1,189 lbs
Thrust/Axial	3,470 lbs	1,246 lbs
Moment	7,544 in-lb	2,669 in-lb

Accuracy ±48 arcsec / ±.0007" at 3" Radius

Repeatability ±12 arcsec / ±.0002" at 3" Radius

Optional Accessories

- R180 Reducer (Ratios from 5:1 to 60:1)
- 1/3 hp AC Drive Package with Inverter Duty Motor and Inverter Drive (up to 60 cpm)
- 1/3 hp DC Motor with Varipak DC Motor Control (up to 30 cpm)
- Single or Dual Cycle Cam and Limit Switch
- Left Hand Cam
- Relief in Dwell for shot-pin applications

Dimensions and technical information are subject to change without notice.

110RGD/110RGS Product Overview, Technical Information

110RGD

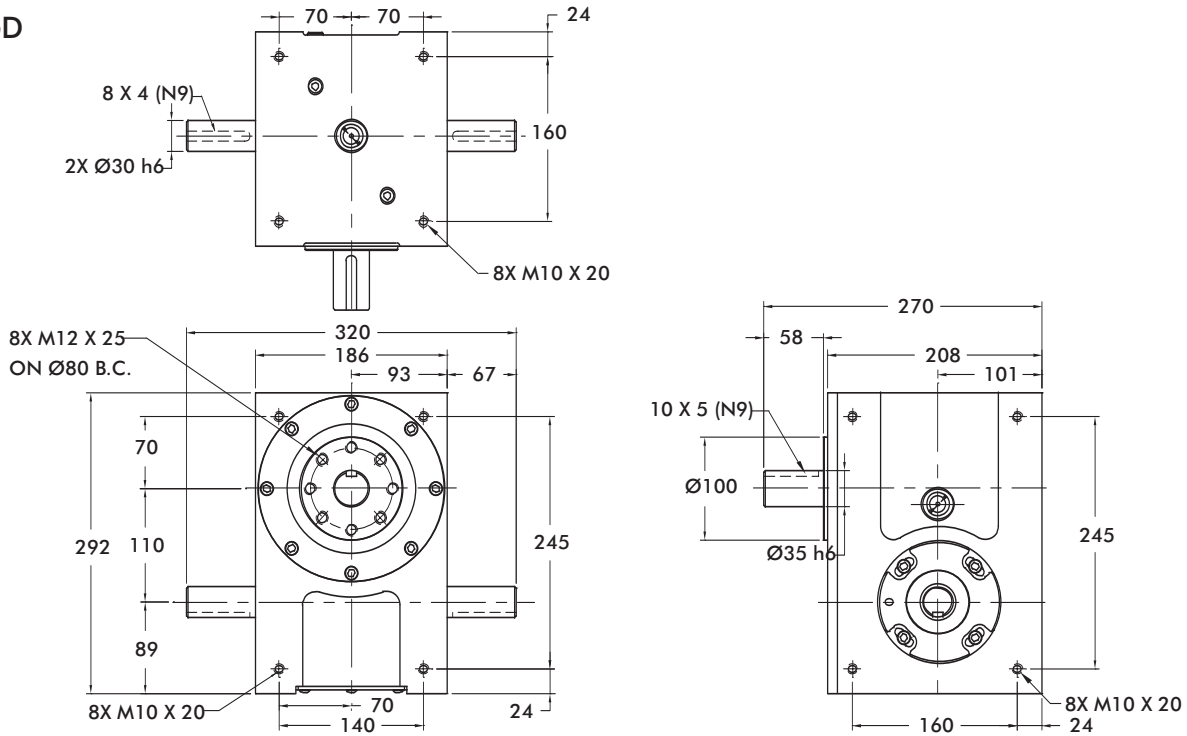

110RGS

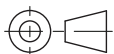
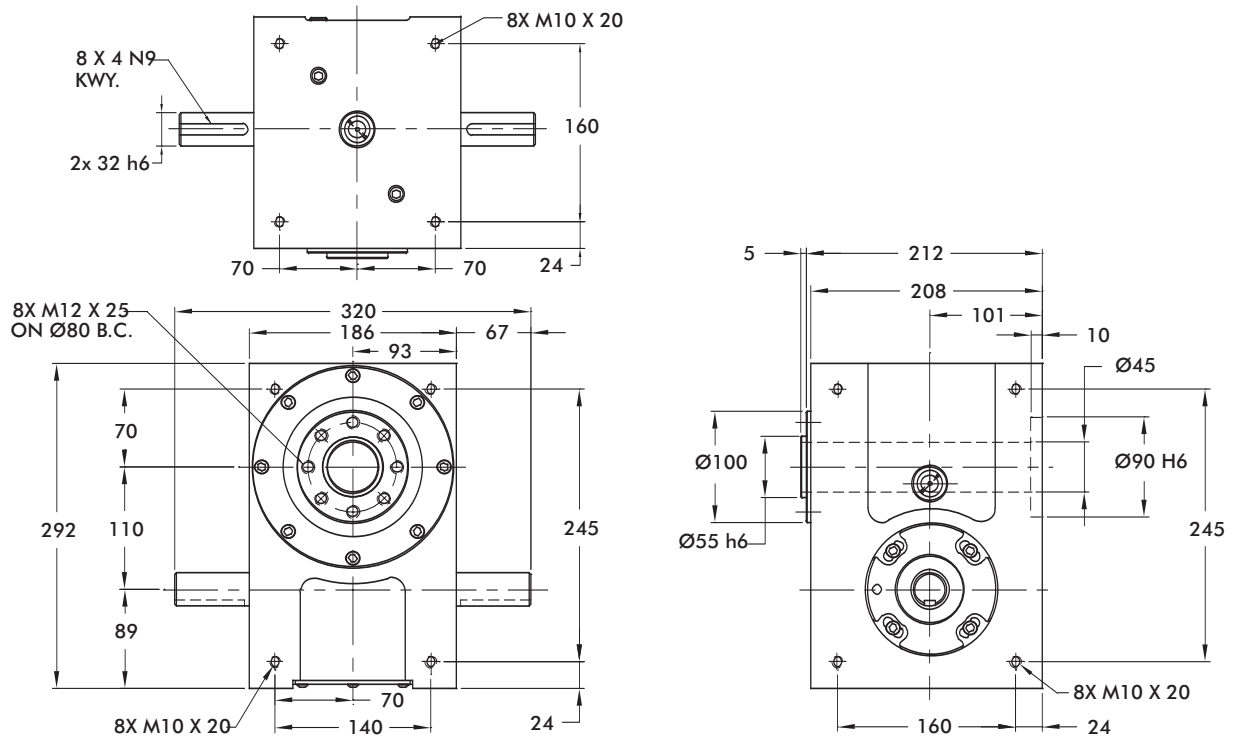

Unless otherwise noted,
all dimensions are in mm.

Dimensions and technical information are subject to change without notice.



110RGD/110RGS Product Overview, Technical Information

110RGD/110RGS Indexer Capacities						
Stops	Index Period	Motion	B ₁₀ Capacity at 50 RPM (in-lb)	RGD Internal Inertia (lb-in ²)	RGS Internal Inertia (lb-in ²)	Model
2	300	msc.33	5271	51	56	110RG(D/S)2H40-300
	270	msc.50	6126	51	56	110RG(D/S)2H40-270
3	270	ms	5609	51	56	110RG(D/S)3H40-270
	180	msc.50	7829	51	56	110RG(D/S)3H40-180
4	270	ms	3282	48	55	110RG(D/S)4H32-270
	180	msc.33	4147	48	55	110RG(D/S)4H32-180
6	270	ms	7378	52	70	110RG(D/S)6H48-270
	120	msc.33	8127	51	56	110RG(D/S)6H40-120
8	270	ms	3440	48	55	110RG(D/S)8H32-270
	120	ms	4149	48	55	110RG(D/S)8H32-120
12	270	ms	2815	47	55	110RG(D/S)12H28-270
	120	ms	3367	45	51	110RG(D/S)12H24-120
16	270	ms	1610	45	53	110RG(D/S)16H20-270
	120	ms	1992	45	53	110RG(D/S)16H20-120
24	270	ms	3650	45	51	110RG(D/S)24H24-270 II
	180	ms	4134	45	51	110RG(D/S)24H24-180 II

Other Motions (stops and index periods) available. Contact your DE-STA-CO sales representative for more information.

Features

- Fully Metric
- Universal Mounting: mounting holes on any of 6 sides
- Center Through Hole (1.77 in./45 mm Diameter) in RGD model.
- Right Hand Cam

Output Load Capacity (loads carried during index):

	RGD	RGS
Radial	5,613 lbs	1,856 lbs
Thrust/Axial	4,411 lbs	2,053 lbs
Moment	11,050 in-lb	4,238 in-lb

Accuracy ±30 arcsec / ±.0009" at 6" Radius

Repeatability ±8 arcsec / ±.0002" at 6" Radius

Optional Accessories

- KH37 Reducer
 - Ratios from 5.36:1 to 106.38:1 (consult factory for exact ratios available)
 - 1 hp AC Drive Package with Inverter Duty Motor and Inverter Drive (up to 60 cpm)
- Single or Dual Cycle Cam and Limit Switch
- Left Hand Cam
- Relief in Dwell for shot-pin applications

Dimensions and technical information are subject to change without notice.



350RGD/350RGS Product Overview, Technical Information

350RGD

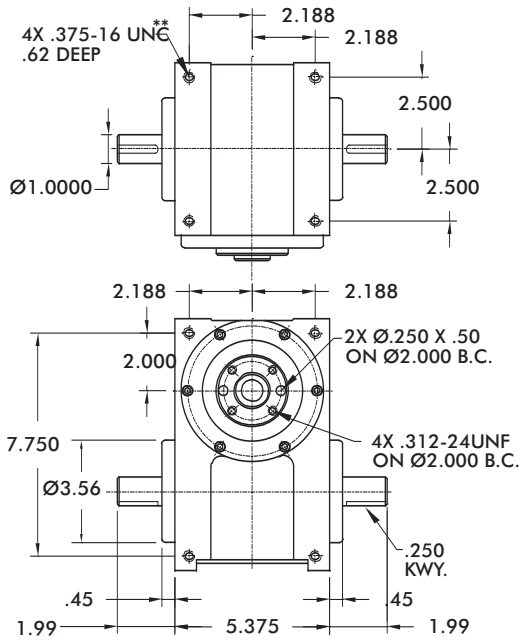

** 4 TAPPED MOUNTING HOLES IN ANY ONE OF SIX FINISHED SIDES, TO BE SPECIFIED BY CUSTOMER

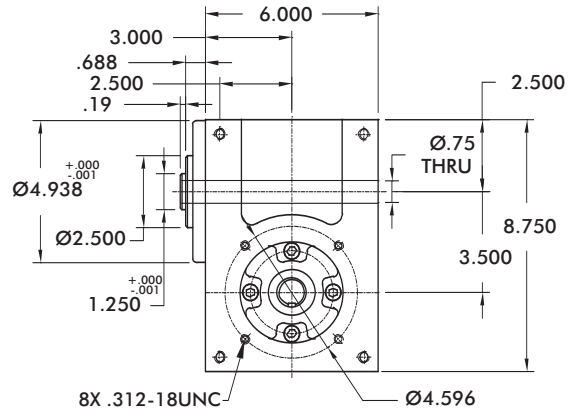

350RGS

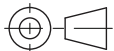
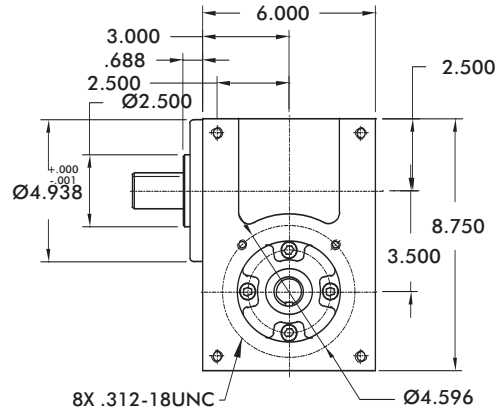
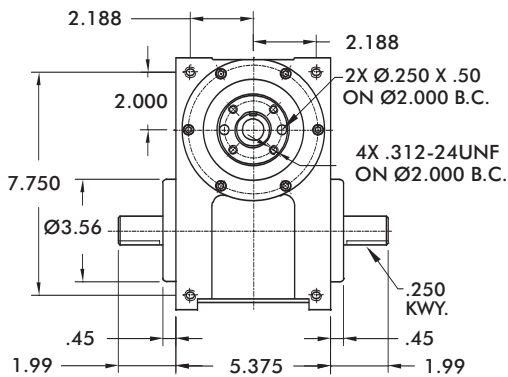
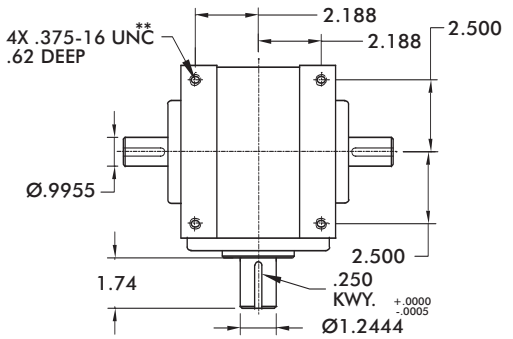

Unless otherwise noted, all dimensions are in mm.

Dimensions and technical information are subject to change without notice.



350RGD/350RGS Product Overview, Technical Information

350RGD/350RGS Indexer Capacities						
Stops	Index Period	Motion	B ₁₀ Capacity at 50 RPM (in-lb)	RGD Internal Inertia (lb-in ²)	RGS Internal Inertia (lb-in ²)	Model
1	330	msc.50	1774	7.7	9.7	350RG(D/S)1H24-330
2	270	ms	1244	7.7	9.7	350RG(D/S)2H24-270
	180	msc.67	2047	7.7	9.7	350RG(D/S)2H24-180
3	270	ms	1530	7.7	9.7	350RG(D/S)3H24-270
	180	ms	1601	7.7	9.7	350RG(D/S)3H24-180
4	300	ms	1701	8.1	10.1	350RG(D/S)4H24-300
	180	ms	2001	8.1	10.1	350RG(D/S)4H24-180
6	270	ms	1615	7.7	9.7	350RG(D/S)6H24-270
	90	ms	2063	7.7	9.7	350RG(D/S)6H24-90
8	270	ms	1840	8.1	10.1	350RG(D/S)8H24-270
	90	ms	2716	8.1	10.1	350RG(D/S)8H24-90
12	270	ms	1132	7.9	9.9	350RG(D/S)12H20-270
	90	ms	1476	7.9	9.9	350RG(D/S)12H20-90

Other Motions (stops and index periods) available. Contact your DE-STA-CO sales representative for more information.

Features

- Universal Mounting: mounting holes on any of 6 sides
- Center Through Hole (.75 in. Diameter) in RGD model.
- Right Hand Cam Standard

Output Load Capacity (loads carried during index):

	RGD	RGS
Radial	1,935 lbs	1,808 lbs
Thrust/Axial	1,406 lbs	786 lbs
Moment	2,419 in-lb	3,164 in-lb

Accuracy ±41 arcsec / ±.0012" at 6" Radius

Repeatability ±10 arcsec / ±.0003" at 6" Radius

Optional Accessories

- R180 Reducer (Ratios from 5:1 to 60:1)
 - 1/3 hp AC Drive Package with Inverter Duty Motor and Inverter Drive (up to 60 cpm)
 - 1/3 hp DC Motor with Varipak DC Motor Control (up to 30 cpm)
- R225 Reducer (Ratios from 5:1 to 60:1)
 - 56C Motor Adapter and Coupling
 - 1 hp AC Drive Package with Inverter Duty Motor and Inverter Drive (up to 60 cpm)
 - 1 hp DC Motor with Varipak DC Motor Control (up to 30 cpm)
- Single or Dual Cycle Cam and Limit Switch
- Relief in Dwell for shot-pin applications
- Left Hand Cam
- Relief in Dwell for shot-pin applications

Dimensions and technical information are subject to change without notice.



500RGD/500RGS Product Overview, Technical Information

500RGD

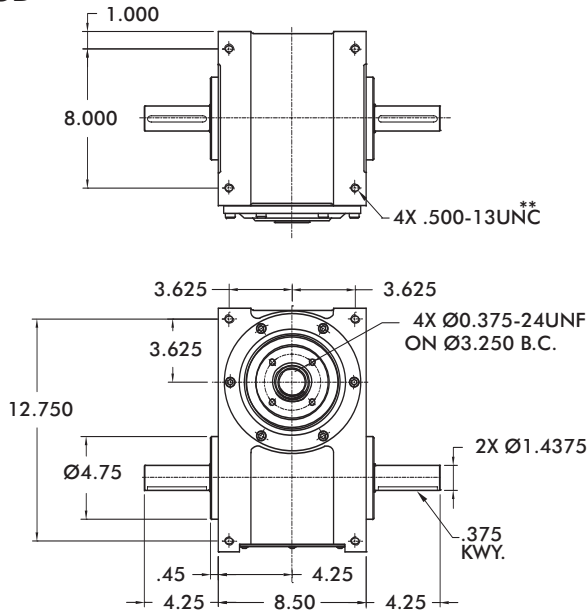

** 4 TAPPED MOUNTING HOLES IN ANY ONE OF SIX FINISHED SIDES, TO BE SPECIFIED BY CUSTOMER

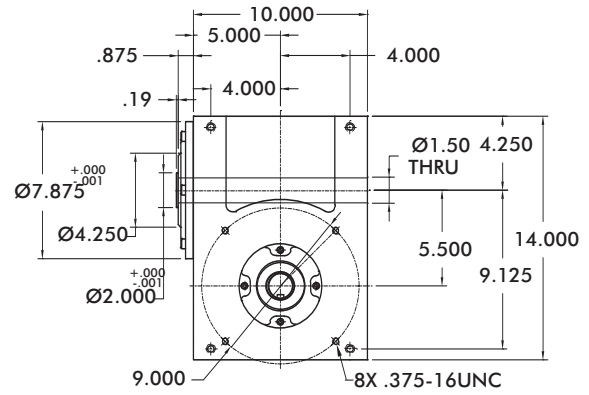

500RGS

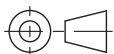
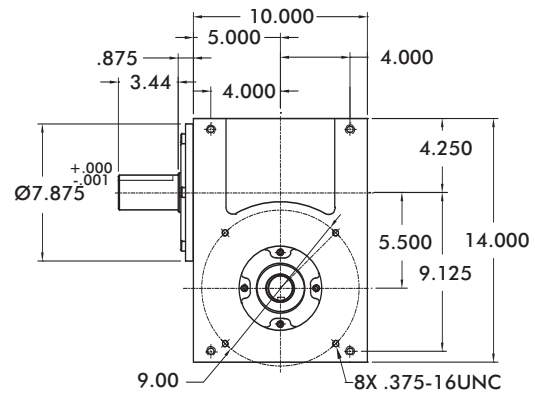
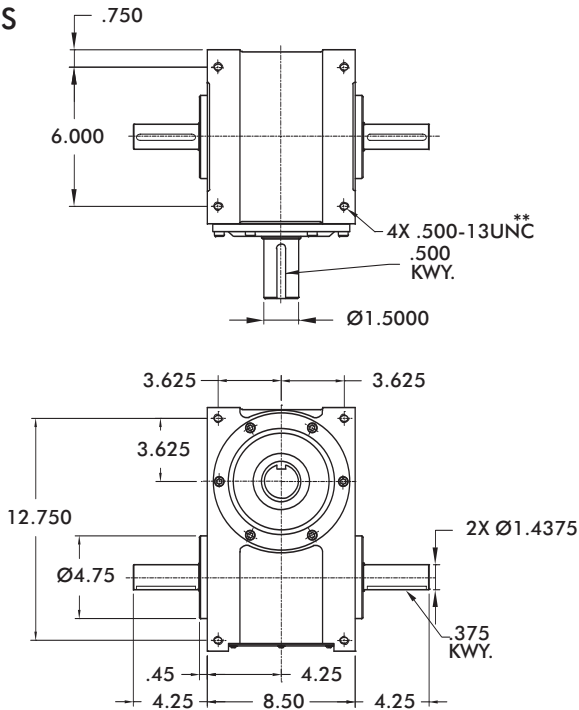

Unless otherwise noted, all dimensions are in mm.

Dimensions and technical information are subject to change without notice.



500RGD/500RGS Product Overview, Technical Information

500RGD/500RGS Indexer Capacities						
Stops	Index Period	Motion	B ₁₀ Capacity at 50 RPM (in-lb)	RGD Internal Inertia (lb-in ²)	RGS Internal Inertia (lb-in ²)	Model
1	330	msc.60	6767	62	45	500RG(D/S)1H40-330
2	270	ms	4400	62	45	500RG(D/S)2H40-270
3	270	ms	5265	62	45	500RG(D/S)3H40-270
	180	ms	5706	62	45	500RG(D/S)3H40-180
4	270	ms	6121	66	48	500RG(D/S)4H40-270
	120	msc.20	3892	60	42	500RG(D/S)4H32-120
6	270	ms	5464	62	45	500RG(D/S)6H40-270
	90	ms	6909	62	45	500RG(D/S)6H40-90
8	270	ms	6151	66	48	500RG(D/S)8H40-270
	90	ms	8219	66	48	500RG(D/S)8H40-90
12	270	ms	2616	58	40	500RG(D/S)12H28-270
	90	ms	3449	58	40	500RG(D/S)12H28-90

Other Motions (stops and index periods) available. Contact your DE-STA-CO sales representative for more information.

Features

- Universal Mounting: mounting holes on any of 6 sides
- Center Through Hole (1.50 in. Diameter) in RGD model.
- Right Hand Cam Standard

Output Load Capacity (loads carried during index):

	RGD	RGS
Radial	4,004 lbs	3,767 lbs
Thrust/Axial	2,759 lbs	1,433 lbs
Moment	8,509 in-lb	12,959 in-lb

Accuracy ±29 arcsec / ±.0008" at 6" Radius

Repeatability ±7 arcsec / ±.0002" at 6" Radius

Optional Accessories

- R225 Reducer (Ratios from 5:1 to 60:1)
 - 1 hp AC Drive Package with Inverter Duty Motor and Inverter Drive (up to 60 cpm)
 - 1 hp DC Motor with Varipak DC Motor Control (up to 30 cpm)
- Single or Dual Cycle Cam and Limit Switch
- Output Overload Clutch Models: 11S, 11C, 11F, 11C-SD, 11S-SD, 11FC-SD
 - Available Settings (in-lbs): 2300, 4000, 6000, 8500, 11000
- Left Hand Cam
- Relief in Dwell for shot-pin applications
- Left Hand Cam

Dimensions and technical information are subject to change without notice.

600RGD/600RGS Product Overview, Technical Information

600RGD

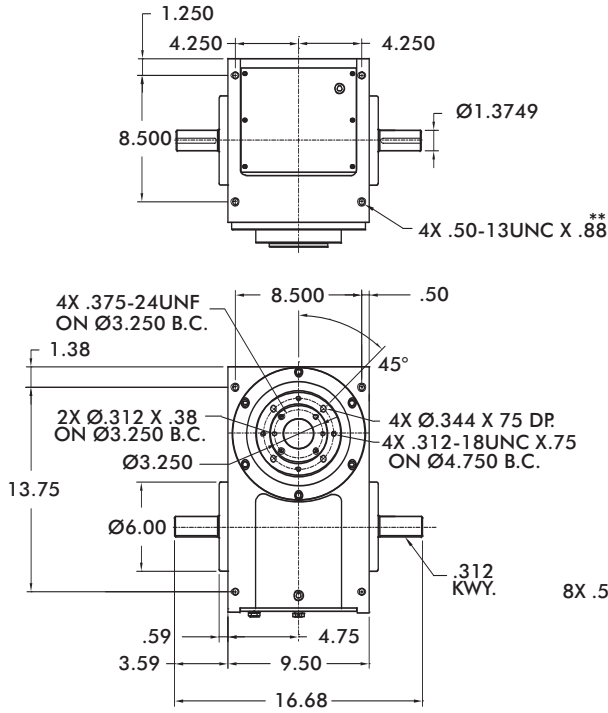

** 4 TAPPED MOUNTING HOLES IN ANY ONE OF SIX FINISHED SIDES, TO BE SPECIFIED BY CUSTOMER

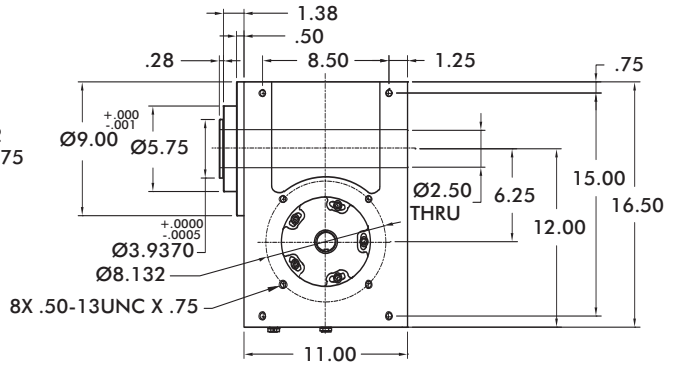

600RGS

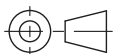
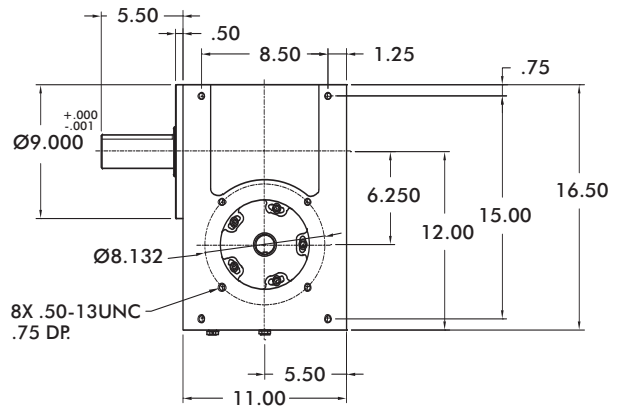
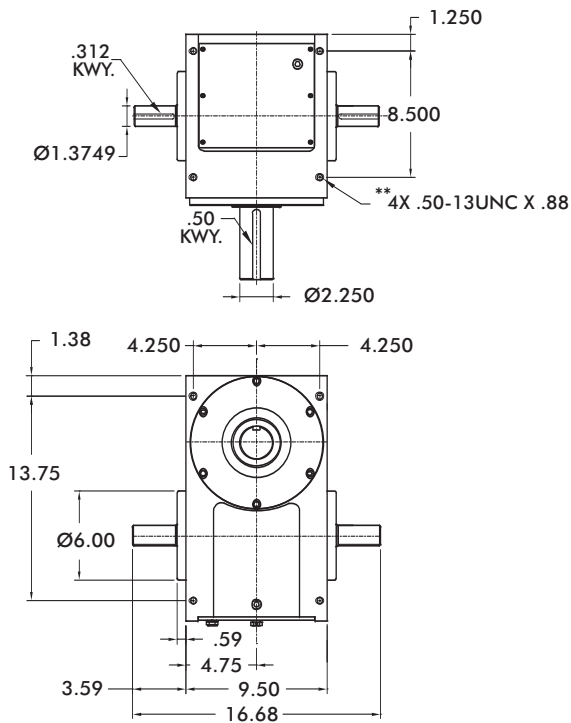

Unless otherwise noted, all dimensions are in mm.

Dimensions and technical information are subject to change without notice.



600RGD/600RGS Product Overview, Technical Information

600RGD/600RGS Indexer Capacities						
Stops	Index Period	Motion	B ₁₀ Capacity at 50 RPM (in-lb)	RGD Internal Inertia (lb-in ²)	RGS Internal Inertia (lb-in ²)	Model
2	300	ms	6516	256	137	600RG(D/S)2H48-300
3	270	ms	7955	256	137	600RG(D/S)3H48-270
	180	ms	8769	256	137	600RG(D/S)3H48-180
4	270	ms	6749	249	131	600RG(D/S)4H40-270
	180	ms	7477	249	131	600RG(D/S)4H40-180
6	270	ms	8286	256	137	600RG(D/S)6H48-270
	90	ms	10715	256	137	600RG(D/S)6H48-90
8	270	ms	6928	244	126	600RG(D/S)8H40-270
	90	ms	8936	244	126	600RG(D/S)8H40-90
12	270	ms	4091	244	126	600RG(D/S)12H32-270
	90	ms	5444	244	126	600RG(D/S)12H32-90
16	270	ms	9553	249	131	600RG(D/S)16H40-270 II
	90	ms	12224	249	131	600RG(D/S)16H40-90 II

Other Motions (stops and index periods) available. Contact your DE-STA-CO sales representative for more information.

Features

- Universal Mounting: mounting holes on any of 6 sides
- Center Through Hole (2.50 in. Diameter) in RGD model.
- Right Hand Cam Standard

Output Load Capacity (loads carried during index):

	RGD	RGS
Radial	5,667 lbs	3,828 lbs
Thrust/Axial	3,528 lbs	3,529 lbs
Moment	16,292 in-lb	18,451 in-lb

Accuracy ±40 arcsec / ±.0011" at 6" Radius

Repeatability ±10 arcsec / ±.0003" at 6" Radius

Optional Accessories

- 7300C or 7350C Reducer (Ratios from 5:1 to 60:1)
- 1 or 2 hp AC Drive Package with Inverter Duty Motor and Inverter Drive (up to 60 cpm)
- 1 or 2 hp DC Motor with Varipak DC Motor Control (up to 30 cpm)
- Single or Dual Cycle Cam and Limit Switch
- Output Overload Clutch Models: 11FM, 11SM – Available Settings (in-lbs): 2300, 4000, 6000, 8500, 11000
- Left Hand Cam
- Relief in Dwell for shot-pin applications
- Left Hand Cam

Dimensions and technical information are subject to change without notice.

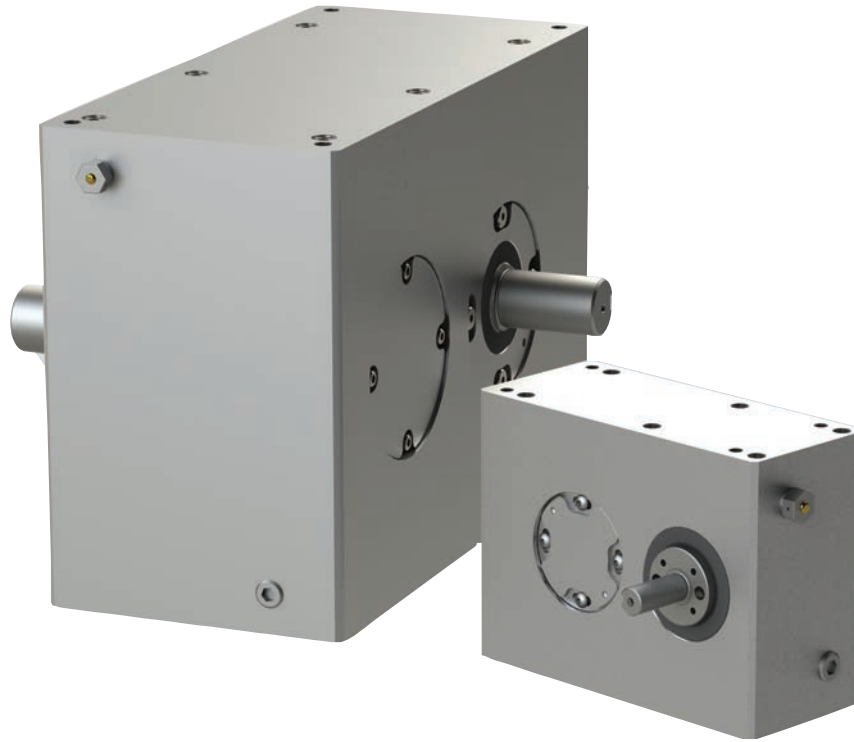

Features:

Camco Parallel Index Drives are ideal for high-speed applications or for actuation-type applications such as driving a linkage or a conveyor.

- Hardened and ground conjugate cams
- Yoke-mounted, preloaded cam followers are non-reversing for high capacity and speed capability
- Whole or fractional stops, oscillating and complex custom motions are available
- Long transfer distances achieved with simple linkages
- Preloaded, tapered roller bearings for rigidity and backlash-free operation

Table of Contents

How to Order	138
250P	140
387P	142
512P	144
662P	146

Dimensions and technical information are subject to change without notice.



P Series How to Order

Indexer Ordering Procedure

1. Input Assembly: Right, Left or Double (DE)
2. Output Assembly: Right, Left or Double (DE).
 - Flanged output is primary output. For Double Output, specify whether flanged output is on right or left side.

NOTE: Input may rotate in either direction to achieve desired direction of output rotation.

3. Mounting Position: 1-6

Reducer Ordering Procedure

1. Model
2. Ratio: 5:1, 10:1, 15:1, 20:1, 25:1, 30:1, 40:1, 50:1, 60:1
3. Motor Adapter
4. Reducer Input Shaft Extension: Single Input (SE) or Double Input (DE)
5. Mounting (see diagram below)

Position of Shafts (Top View)

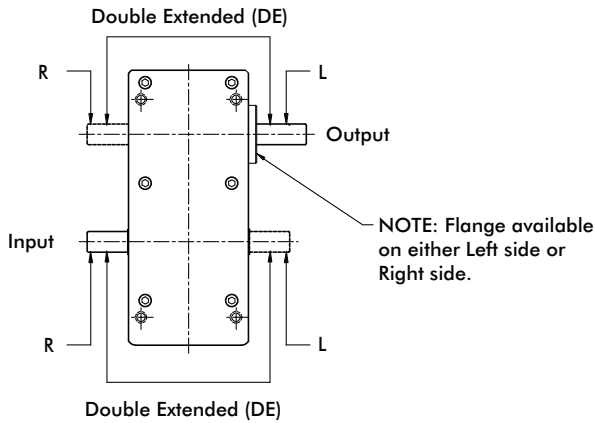

Input/Output Shaft Rotation

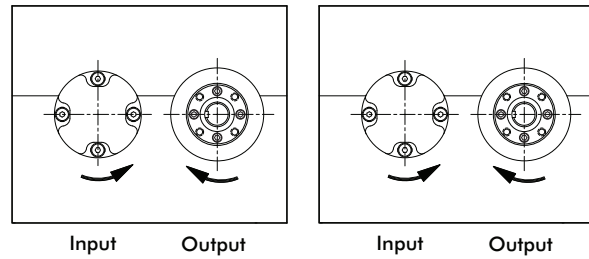

Dimensions and technical information are subject to change without notice.



Indexer Mounting Position

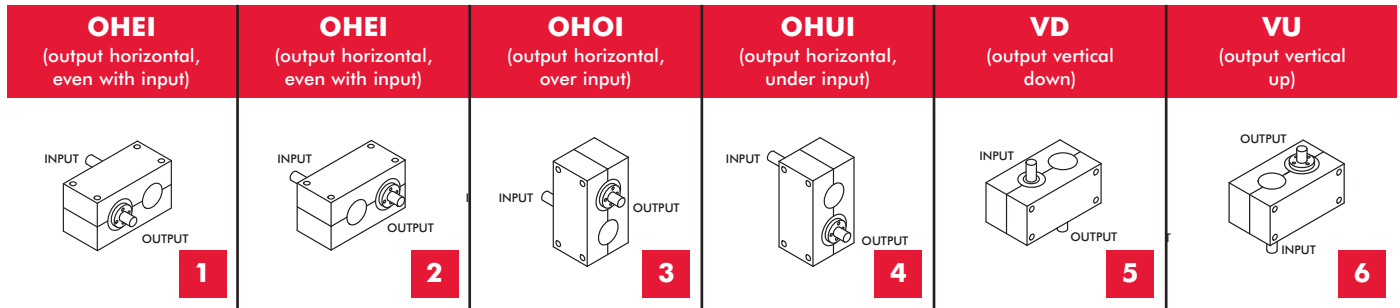

Gear Reducer Mounting Positions (Figure 4)

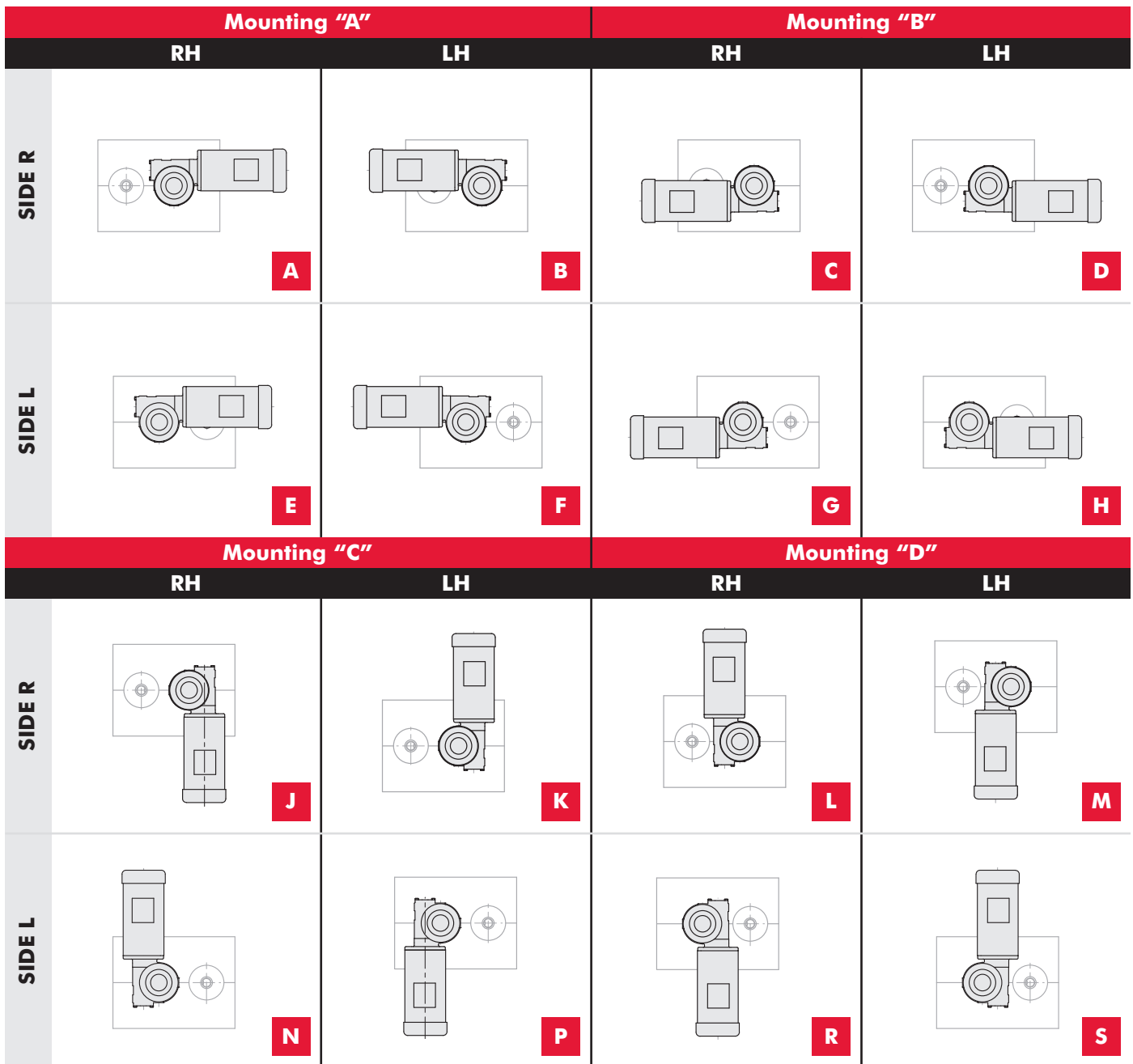

Dimensions and technical information are subject to change without notice.

250P Standard Dimensions

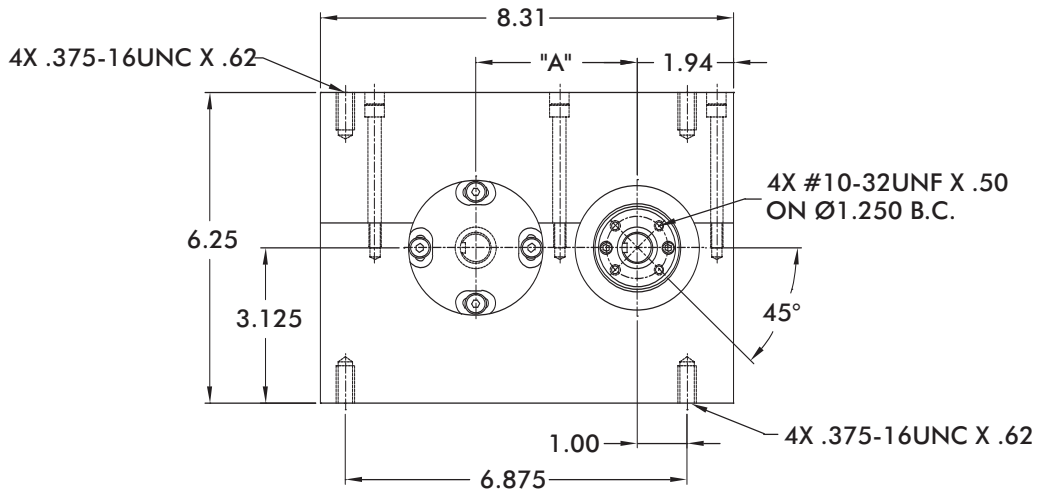
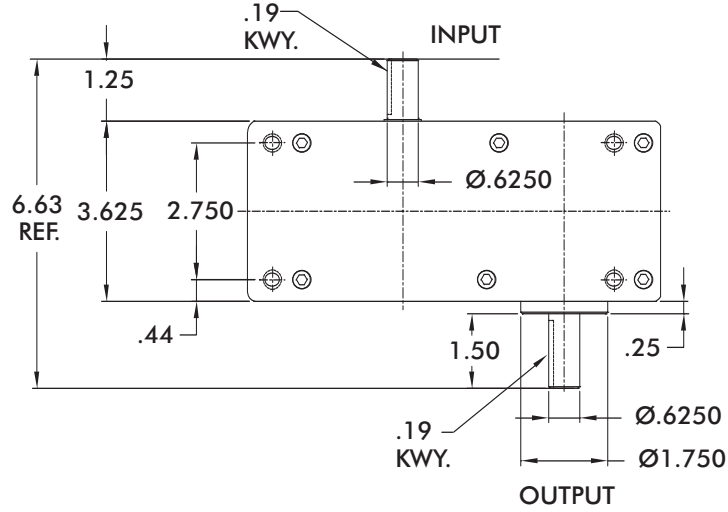

Dimensions and technical information are subject to change without notice.



250P Product Overview and Technical Specifications

250P Indexer Capacities						
Stops	Index Period	Motion	B ₁₀ Capacity at 50 RPM (in-lb)	Internal Inertia (lb-in ²)	Model	"A" Center
1	300	msc.50	444	3	250P1H20-300	3.25
1.5	270	msc.33	481	2	250P1.5H20-270	3.25
2	270	ms	433	3	250P2H20-270	3.25
	180	msc.33	546	3	250P2H20-180	3.25
3	270	ms	582	2	250P3H20-270	2.75
	120	ms	653	2	250P3H20-120	3.25
4	270	ms	571	3	250P4H20-270	2.75
	90	msc.25	782	3	250P4H20-90	3.25
6	270	ms	888	2	250P6H20-270 II	2.75
	180	msc.33	2078	3	250P6H24-180 II	2.75
8	270	ms	843	3	250P8H20-270 II	2.75
	120	ms	993	3	250P8H20-120 II	3.25

Other Motions (stops and index periods) available. Contact your DE-STA-CO sales representative for more information.

Features

- Single Input Shaft and Single Output Shaft
- Output horizontal even with input Mounting
- R180 Reducer (ratios from 15:1 to 60:1)
 - Double Extended Worm (input) Shaft
 - Worm Shaft Handwheel
- 1/3 or 1 hp AC Drive Package with Inverter Duty Motor and Inverter Drive (up to 60 cpm)
- Single Cycle Cam and Limit Switch

Output Load Capacity (loads carried during index):

- Radial 316 lbs
- Thrust/Axial 314 lbs
- Moment 395 in-lb

Accuracy ±77 arcsec / ±.0011" at 3" Radius

Repeatability ±19 arcsec / ±.0003" at 3" Radius

Optional Accessories

- 1/3 hp DC motor
- Varipak DC Motor Control (up to 30 cpm)
- R225 Reducer (ratios from 10:1 to 60:1)
 - 1 hp AC or DC drive package
 - 56C Motor Adapter and Coupling
- Output Overload Clutch Models: .39F, .39FC, .39S and .39C, .39C-SD, .39FC-SD, .39S-SD
 - Available Settings (in-lb): 160, 210, 270, 320, 390
- Dual Cycle Cam and Limit Switch
- Oscillating motion
- Double Input Shaft
- Double Output Shaft
- Output and Input Vertical Mounting

Dimensions and technical information are subject to change without notice.



387P Standard Dimensions

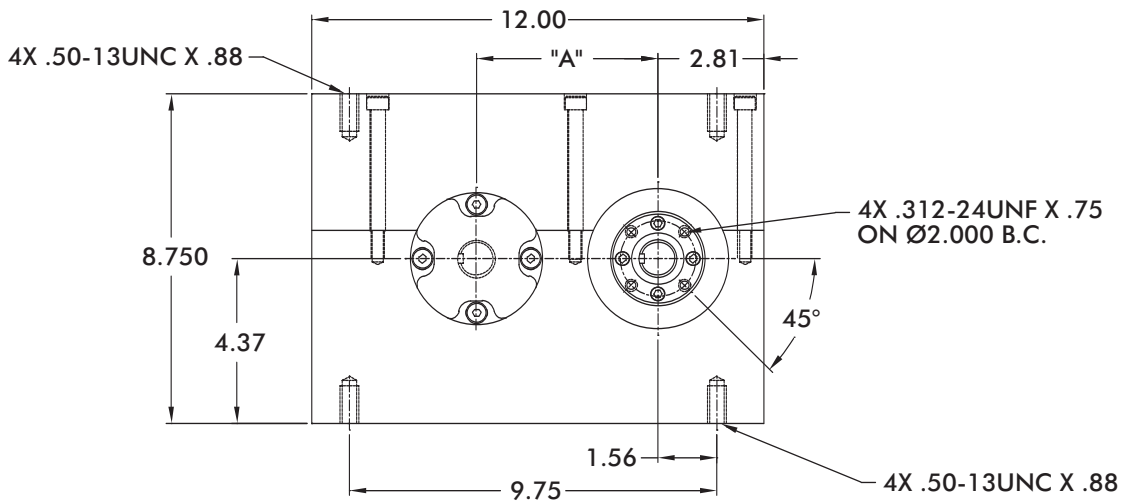
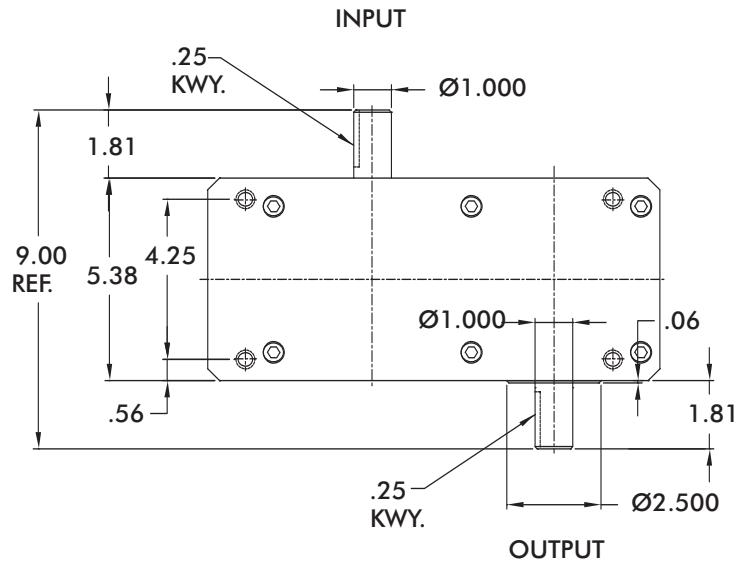

Dimensions and technical information are subject to change without notice.



387P Product Overview and Technical Specifications

387P Indexer Capacities						
Stops	Index Period	Motion	B ₁₀ Capacity at 50 RPM (in-lb)	Internal Inertia (lb-in ²)	Model	"A" Center
1	300	msc.66	1385	14	387P1H28-300	4.812
1.33	315	msc.10	1062	13	387P1.33H28-315	4.812
1.5	300	ms	1099	13	387P1.5H28-300	4.812
2	270	msc.33	1788	14	387P2H32-270	4.812
	180	msc.33	2095	14	387P2H32-180	4.812
2.67	270	msc.33	2171	14	387P2.67H28-270 II	4.812
3	270	ms	1601	13	387P3H28-270	4
	120	msc.33	2067	14	387P3H28-120	4.812
4	270	ms	1605	14	387P4H28-270	4
	90	msc.33	2214	14	387P4H28-90	4.812
6	270	ms	2445	13	387P6H28-270 II	4
	180	ms	2463	13	387P6H28-180 II	4.812
8	270	ms	2378	14	387P8H28-270 II	4

Other Motions (stops and index periods) available. Contact your DE-STA-CO sales representative for more information.

Features

- Single Input Shaft and Single Output Shaft
- Output horizontal even with input Mounting
- R225 Reducer (ratios from 10:1 to 60:1)
 - 56C Motor Adapter and Coupling
- 1 hp AC Drive Package with Inverter Duty Motor and Inverter Drive (up to 60 cpm)
- Single Cycle Cam and Limit Switch

Output Load Capacity (loads carried during index):

Radial	895 lbs
Thrust/Axial	577 lbs
Moment	1,620 in-lb

Accuracy ±50 arcsec / ±.0007" at 3" Radius

Repeatability ±12 arcsec / ±.0002" at 3" Radius

Optional Accessories

- 1 hp DC motor
- Varipak DC Motor Control (up to 30 cpm)
- R260 Reducer (ratios from 5:1 to 60:1)
 - 1 hp AC or DC drive package
 - 56C Motor Adapter and Coupling
- Output Overload Clutch Models: 2.3F, 2.3FC, 2.3S and 2.3C, 2.3C-SD, 2.3FC-SD, 2.3S-SD
 - Available Settings (in-lb): 400, 600, 700, 850, 1000, 1300, 1800, 2000, 2300
- Dual Cycle Cam and Limit Switch
- Oscillating motion
- Double Input Shaft
- Double Output Shaft
- Output and Input Vertical Mounting

Dimensions and technical information are subject to change without notice.

512P Standard Dimensions

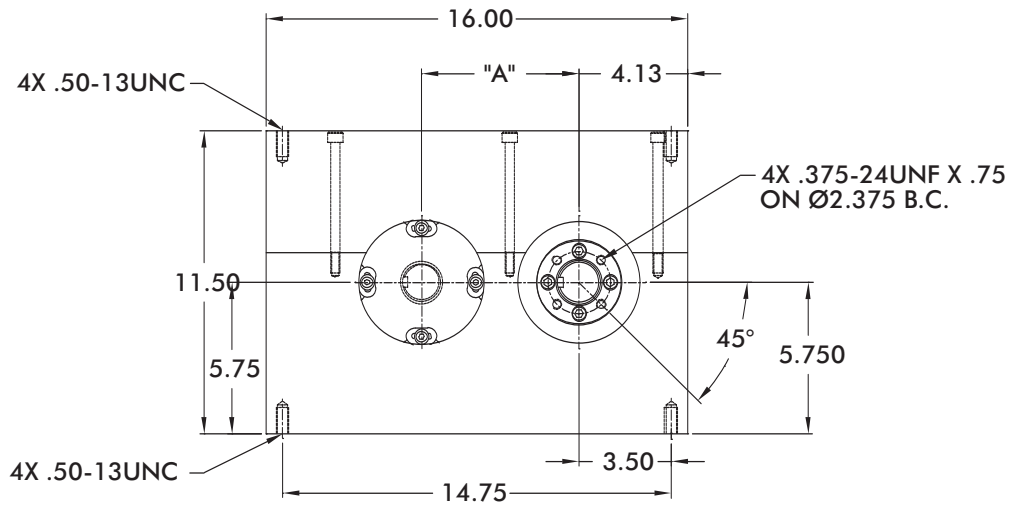
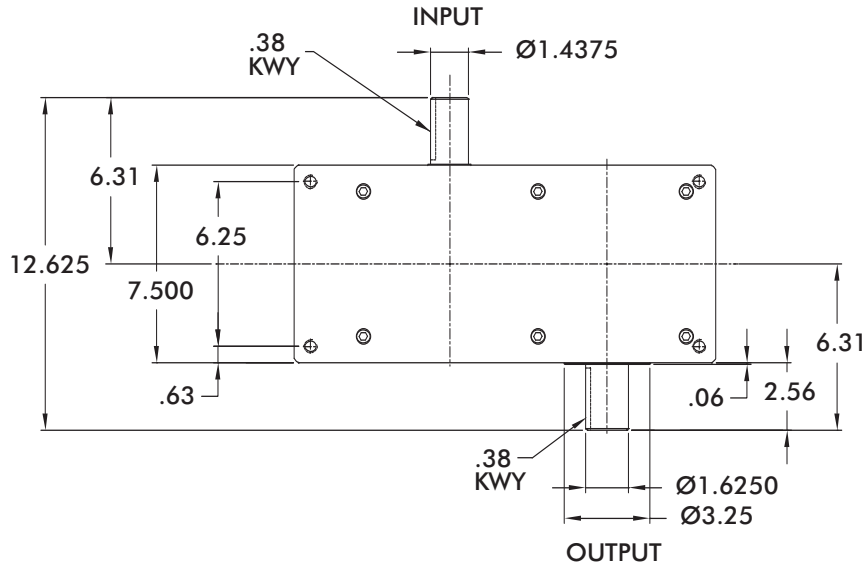

Dimensions and technical information are subject to change without notice.



512P Product Overview and Technical Specifications

512P Indexer Capacities						
Stops	Index Period	Motion	B ₁₀ Capacity at 50 RPM (in-lb)	Internal Inertia (lb-in ²)	Model	"A" Center
1	330	msc.75	6441	63	512P1H48-330	5.979
1.33	330	msc.33	4928	61	512P1.33H48-330	5.979
1.5	330	ms	4860	63	512P1.5H48-330	5.979
	270	msc.33	4373	61	512P2H40-270	5.979
2	180	msc.50	5416	61	512P2H40-180	5.979
	120	msc.50	4131	61	512P2H40-120	5.979
3	300	msc.33	7116	61	512P2.67H40-300 II	5.979
	180	ms	5462	56	512P3H40-180	5.979
4	270	ms	5619	61	512P4H40-270	4.858
	120	ms	6252	61	512P4H40-120	5.979
6	270	ms	8315	56	512P6H40-270 II	4.858
	180	ms	8261	56	512P6H40-180 II	5.979
8	270	ms	8387	61	512P8H40-270 II	4.858
	180	ms	7894	61	512P8H40-180 II	5.979

Other Motions (stops and index periods) available. Contact your DE-STA-CO sales representative for more information.

Features

- Single Input Shaft and Single Output Shaft
- Output horizontal even with input Mounting
- R225 Reducer (ratios from 10:1 to 60:1)
 - 56C Motor Adapter and Coupling
- 1 hp AC Drive Package with Inverter Duty Motor and Inverter Drive (up to 60 cpm)
- Single Cycle Cam and Limit Switch

Output Load Capacity (loads carried during index):

- Radial 2,715 lbs
- Thrust/Axial 1,374 lbs
- Moment 6,951 in-lb

Accuracy ±37 arcsec / ±.0005" at 3" Radius

Repeatability ±9 arcsec / ±.0001" at 3" Radius

Optional Accessories

- 1 hp DC motor
- Varipak DC Motor Control (up to 30 cpm)
- R260 Reducer (ratios from 5:1 to 60:1)
 - 1 hp AC or DC drive package
 - 56C Motor Adapter and Coupling
- Output Overload Clutch Models: 6.0F, 6.0FC, 6.0S and 6.0C, 6.0C-SD, 6.0FC-SD, 6.0S-SD
 - Available Settings (in-lb): 670, 825, 1100, 1400, 1700, 2000, 2300, 2500, 3000, 3800, 4000, 5000, 6000
- Dual Cycle Cam and Limit Switch
- Oscillating motion
- Double Input Shaft
- Double Output Shaft
- Output and Input Vertical Mounting

Dimensions and technical information are subject to change without notice.



For more information or to place an order call 1-800-645-5207 or www.camco.com or camco@destaco.com

destaco.com

662P Standard Dimensions

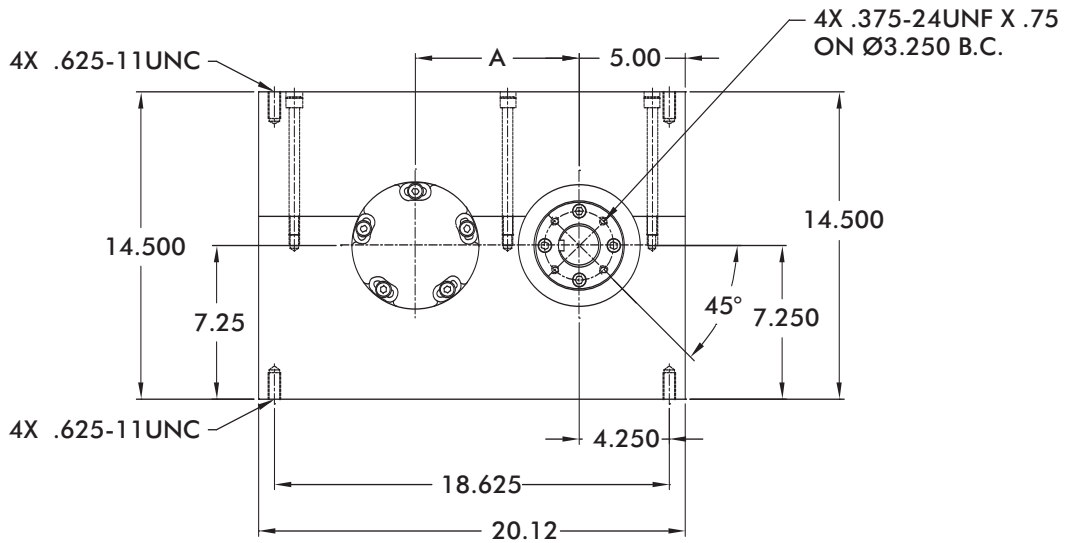
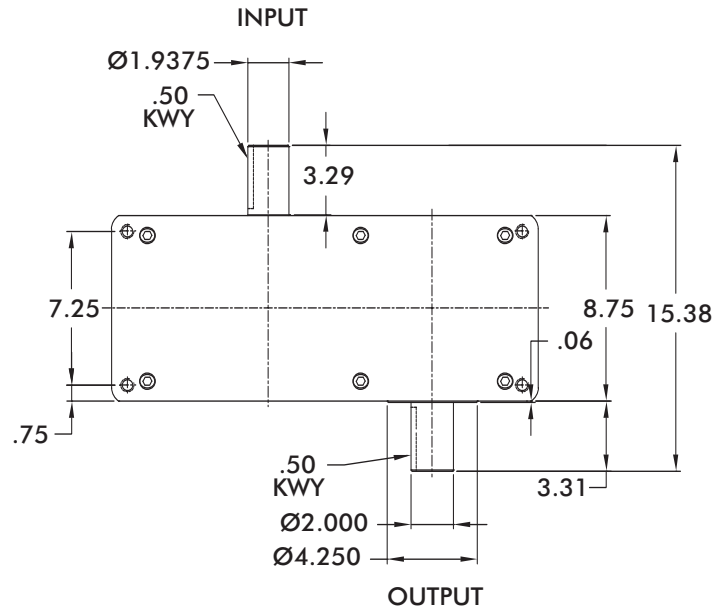

Dimensions and technical information are subject to change without notice.



662P Product Overview and Technical Specifications

662P Indexer Capacities						
Stops	Index Period	Motion	B ₁₀ Capacity at 50 RPM (in-lb)	Internal Inertia (lb-in ²)	Model	"A" Center
1	330	msc.50	5824	138	662P1H48-330	7.729
1.33	330	msc.20	10368	332	662P1.33H64-330	7.729
1.5	270	msc.33	12617	306	662P1.5H64-270	7.729
2	270	msc.33	6811	181	662P2H48-270	7.729
	180	msc.50	11760	204	662P2H56-180	7.729
3	270	ms	8446	166	662P3H48-270	6.628
	180	ms	8506	166	662P3H48-180	7.729
4	270	ms	8752	181	662P4H48-270	6.628
	120	ms	9738	181	662P4H48-120	7.729
6	270	ms	12946	166	662P6H48-270 II	6.628
	180	ms	12863	166	662P6H48-180 II	7.729
8	270	ms	13060	181	662P8H48-270 II	6.628
	120	msc.33	15780	181	662P8H48-120	7.729

Other Motions (stops and index periods) available. Contact your DE-STA-CO sales representative for more information.

Features

- Single Input Shaft and Single Output Shaft
- Output horizontal even with input Mounting
- R225 Reducer (ratios from 10:1 to 60:1) – 56C Motor Adapter and Coupling
- 1 hp AC Drive Package with Inverter Duty Motor and Inverter Drive (up to 60 cpm)
- Single Cycle Cam and Limit Switch

Output Load Capacity (loads carried during index):

- Radial 3,915 lbs
- Thrust/Axial 2,042 lbs
- Moment 12,959 in-lb

Accuracy ±36 arcsec / ±.001" at 6" Radius

Repeatability ±9 arcsec / ±.0003" at 6" Radius

Optional Accessories

- 7350C or 7400C Reducer (ratios from 5:1 to 60:1) with Motor Adapter and Coupling
- 1 hp DC Motor
- Output Overload Clutch Models: 11F, 11FC, 11FC-SD – Available Settings (in-lb): 2300, 4000, 6000, 8500, 11000
- Dual Cycle Cam and Limit Switch
- Electric Clutch-Brake
- Air Clutch-Brake
- Oscillating motion
- Double Input Shaft
- Double Output Shaft
- Output and Input Vertical Mounting

Dimensions and technical information are subject to change without notice.



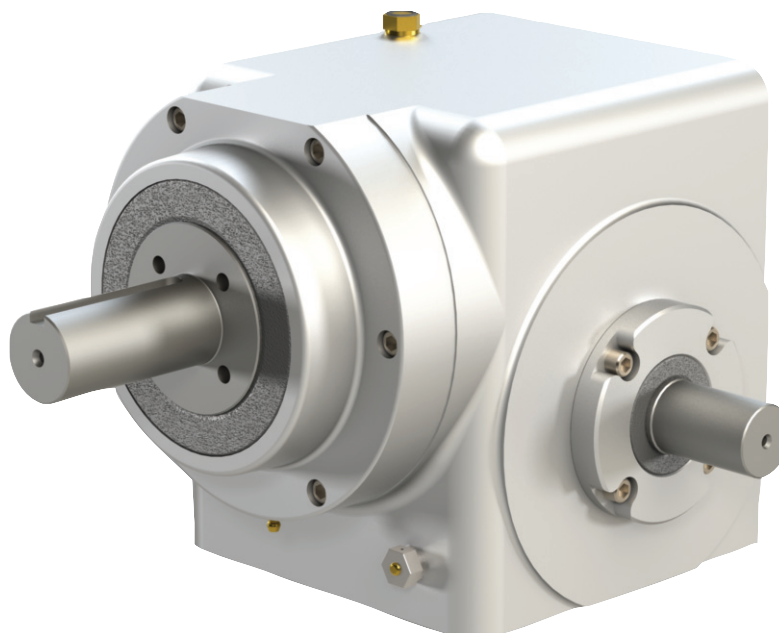

Features:

CAMCO Right Angle Index Drives are ideal for dial applications or actuation-type applications such as driving a linkage or in-line conveyor.

- Fixed center distance between input and output
- Hardened, ground barrel cam
- Compact design requiring minimum use of floor space.
- Preloaded “rib-centered” design with modified-sine motion provides smooth acceleration and deceleration with precision positioning.
- Universal mounting available on RA models.

Table of Contents

How to Order	150
400RA	152
512RA	154
662RA	156

Dimensions and technical information are subject to change without notice.



RA Series How to Order

Indexer Ordering Procedure

1. Model
2. Input Shaft Configuration
 - Side 1
 - Side 2
 - Double Input – DI (Standard)
4. Indexer Mounting Position: 1-6
5. Indexer Housing Mounting Holes: Side 1-6 (more than one side can be selected)

Reducer Ordering Procedure

1. Model
2. Ratio: 5:1, 10:1, 15:1, 20:1, 25:1, 30:1, 40:1, 50:1, 60:1
3. Motor Adapter
4. Reducer Input Shaft Extension: Single Input (SE) or Double Input (DE)
5. Mounting (see diagram below)

Input Shaft Configuration (Top View)

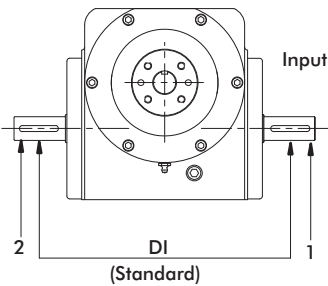

Input Shaft Rotation

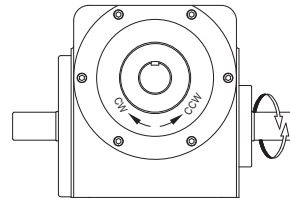

Dimensions and technical information are subject to change without notice.

Indexer Mounting Position

OVOI (output vertical, over input)	OVUI (output vertical, under input)	OHOI (output horizontal, over input)	OHUI (output horizontal, under input)	H-S1-UP (output horizontal, side 1 up)	H-S2-UP (output horizontal, side 2 up)
1	2	3	4	5	6

Gear Reducer Mounting Positions

		Mounting "A"		Mounting "B"	
		RH	LH	RH	LH
SIDE 1	A	B	C	D	
	SIDE 2	E	F	G	H
		Mounting "C"		Mounting "D"	
		RH	LH	RH	LH
SIDE 1	J	K	L	M	
	SIDE 2	N	P	R	S

Dimensions and technical information are subject to change without notice.

400RA Standard Dimensions

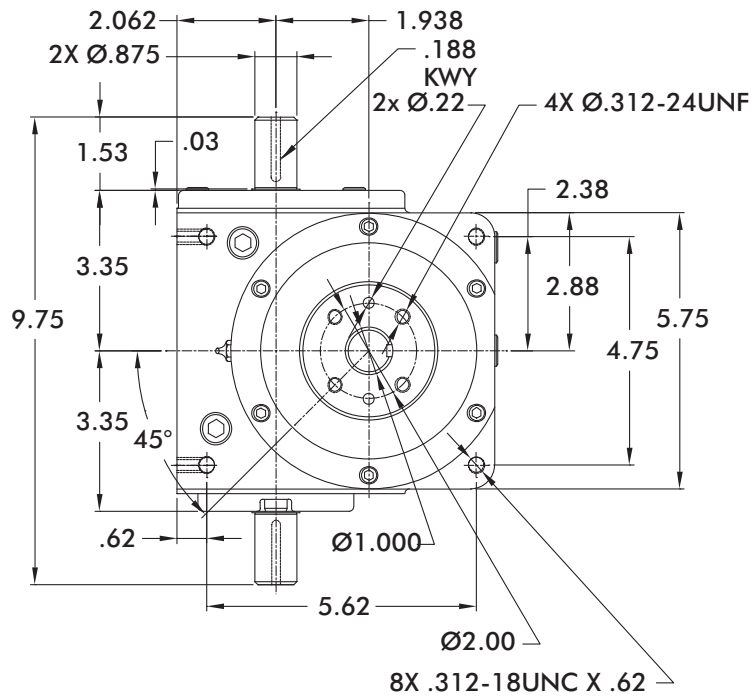

Dimensions and technical information are subject to change without notice.



400RA Product Overview and Technical Specifications

400RA Indexer Capacities					
Stops	Index Period	Motion	B ₁₀ Capacity at 50 RPM (in-lb)	Internal Inertia (lb-in ²)	Model
2	330	ms	595	15	400RA2H20-330
3	270	ms	1591	15	400RA3H24-270
4	270	ms	1858	15	400RA4H24-270
	180	ms	2098	15	400RA4H24-180
6	270	ms	1711	15	400RA6H24-270
	120	ms	2024	15	400RA6H24-120
8	270	ms	1987	15	400RA8H24-270
	120	ms	2354	15	400RA8H24-120
12	270	ms	1290	15	400RA12H20-270
	120	ms	1568	15	400RA12H20-120
16	270	ms	1426	15	400RA16H20-270 II
	180	ms	2947	15	400RA16H24-180 II
24	270	ms	1640	15	400RA24H20-270 II
	180	ms	1894	15	400RA24H20-180 II

Other Motions (stops and index periods) available. Contact your DE-STA-CO sales representative for more information.

Features

- R180 Reducer (ratios from 15:1 to 60:1)
 - Double Extended Worm Shaft (Input)
 - Worm Shaft Handwheel
- Double Extended Camshaft (Input Shaft)
- 1/3 hp AC Drive Package with Inverter Duty Motor and IM-pAC AC Drive (up to 60 cpm)
- Cycle Cam and Limit Switch Mounted to Camshaft
- Right Hand Cam

Output Load Capacity (loads carried during index):

- Radial 810 lbs
- Thrust/Axial 1,406 lbs
- Moment 1,620 in-lb

Accuracy ±48 arcsec / ±.0007" at 3" Radius

Repeatability ±12 arcsec / ±.0002" at 3" Radius

Optional Accessories

- 1/3 hp DC motor
- R225 Reducer (ratios from 10:1 to 60:1)
 - 1 hp DC Motor
 - 56C Motor Adapter and Coupling
- Varipak DC Motor Control (up to 30 cpm)
- Output Overload Clutch Models: 2.3F, 2.3FC, 2.3S, 2.3C, 2.3FC-SD, 2.3S-SD, 2.3C-SD
 - Available Settings (in-lb): 400, 600, 700, 850, 1000, 1300, 1800, 2000, 2300
- Dual Cycle Cam and Limit Switch
- Finished cover for ceiling mount or tooling plate mounting
- Left Hand Cam
- Relief in Dwell for shot-pin applications

Dimensions and technical information are subject to change without notice.



512RA Standard Dimensions

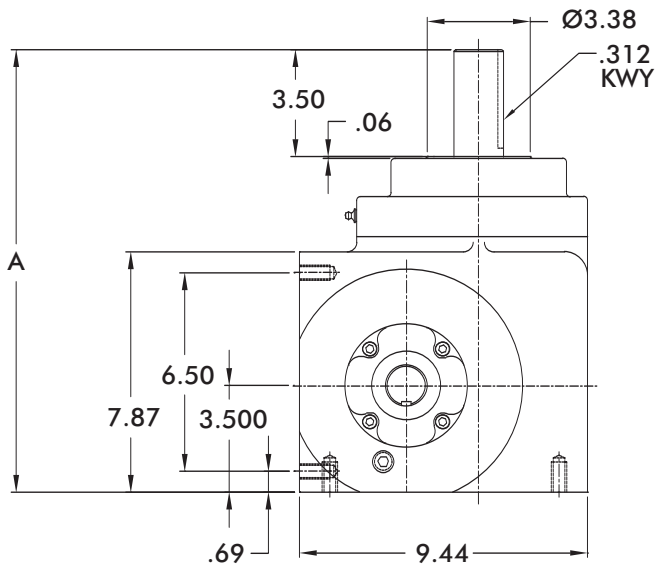
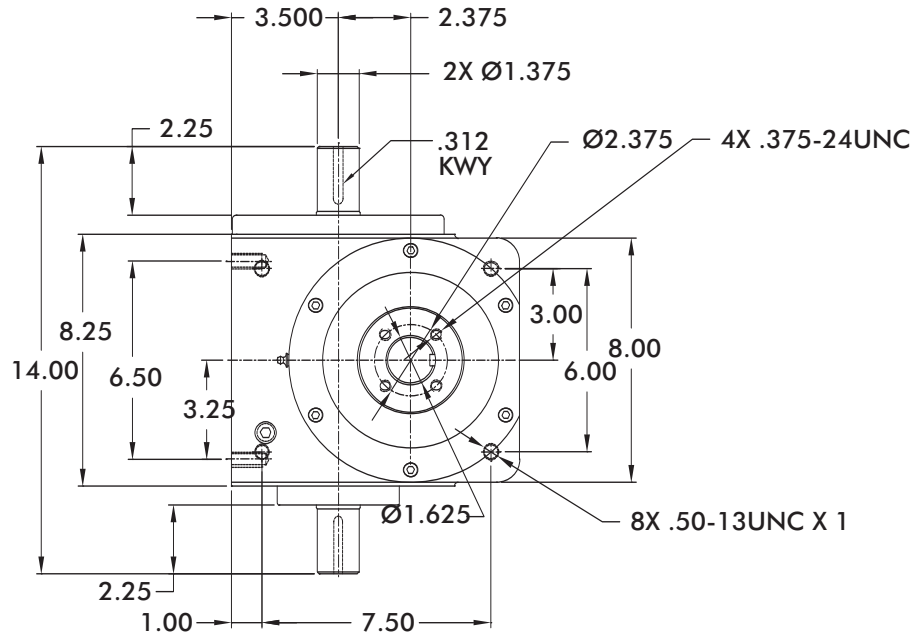

Dimensions and technical information are subject to change without notice.



512RA Product Overview and Technical Specifications

512RA Indexer Capacities						
Stops	Index Period	Motion	B ₁₀ Capacity at 50 RPM (in-lb)	Internal Inertia (lb-in ²)	Model	A
2	270	msc.33	2061	45	512RA2H32-270 MSC.33	14.93
3	270	ms	2360	45	512RA3H32-270	14.50
	180	msc.33	2852	45	512RA3H32-180 MSC 0.33	14.93
4	270	ms	2710	45	512RA4H32-270	14.50
	120	msc.33	3648	45	512RA4H32-120 MSC 0.33	14.93
6	270	ms	2613	45	512RA6H32-270	14.50
	120	ms	3179	45	512RA6H32-120	14.50
8	270	ms	3172	45	512RA8H32-270	14.50
	120	ms	3802	45	512RA8H32-120	14.50
12	270	ms	2738	45	512RA12H28-270	14.50
	120	ms	3176	45	512RA12H28-120	14.93

Other Motions (stops and index periods) available. Contact your DE-STA-CO sales representative for more information.

Features

- R225 Reducer (ratios from 10:1 to 60:1) – 56C Motor Adapter and Coupling
- Double Extended Camshaft (Input Shaft)
- 1 hp AC Drive Package with Inverter Duty Motor and Inverter Drive (up to 60 cpm)
- Cycle Cam and Limit Switch Mounted to Camshaft
- Right Hand Cam

Output Load Capacity (loads carried during index):

- Radial 1,986 lbs
- Thrust/Axial 2,277 lbs
- Moment 6,951 in-lb

Accuracy

±37 arcsec / ±.0011" at 6" Radius

Repeatability

±9 arcsec / ±.0003" at 6" Radius

Optional Accessories

- 1 hp DC motor
- Varipak DC Motor Control (up to 30 cpm)
- Output Overload Clutch Models: 6.0F, 6.0FC, 6.0S and 6.0C, 6.0C-SD, 6.0FC-SD, 6.0S-SD – Available Settings (in-lb): 670, 825, 1100, 1400, 1700, 2000, 2300, 2500, 3000, 3800, 4000, 5000, 6000
- Dual Cycle Cam and Limit Switch
- Finished cover for ceiling mount or tooling plate mounting
- Left Hand Cam
- Relief in Dwell for shot-pin applications

Dimensions and technical information are subject to change without notice.



662RA Standard Dimensions

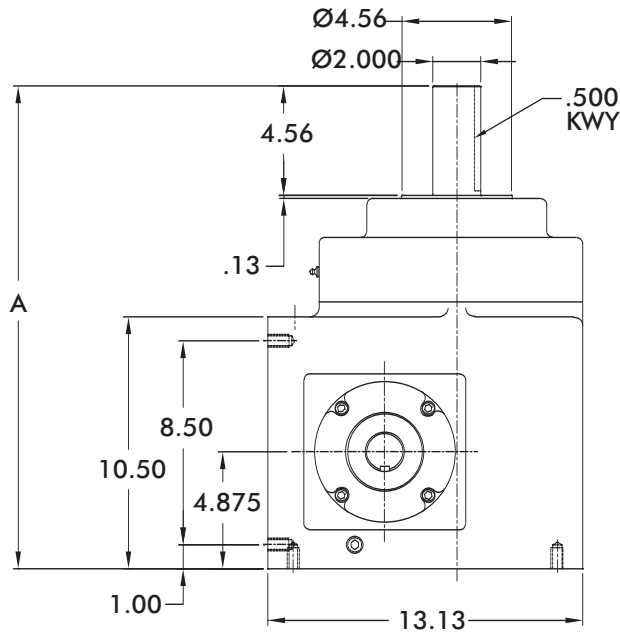
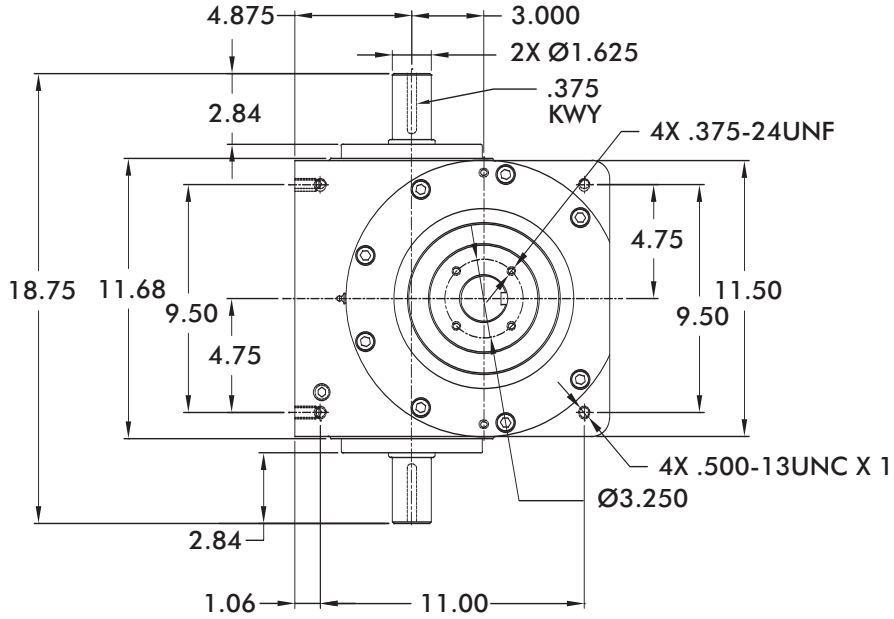

Dimensions and technical information are subject to change without notice.



662RA Product Overview and Technical Specifications

662RA Indexer Capacities						
Stops	Index Period	Motion	B ₁₀ Capacity at 50 RPM (in-lb)	Internal Inertia (lb-in ²)	Model	A
2	270	ms	6534	172	662RA2H48-270	20.88
3	270	ms	5913	169	662RA3H40-270	20.13
	180	ms	6146	169	662RA3H40-180	20.88
4	270	ms	6903	172	662RA4H40-270	20.13
	120	ms	7751	172	662RA4H40-120	20.88
6	270	ms	5734	169	662RA6H40-270	20.13
	120	ms	7551	169	662RA6H40-120	20.13
8	270	ms	7187	172	662RA8H40-270	20.13
	90	ms	8987	172	662RA8H40-90	20.88
12	270	ms	4504	165	662RA12H32-270	20.13
	90	ms	5536	165	662RA12H32-90	20.88

Other Motions (stops and index periods) available. Contact your DE-STA-CO sales representative for more information.

Features

- 7300C Reducer (ratios from 5:1 to 60:1)
 - Motor Adapter and Coupling
- Double Extended Camshaft (Input Shaft)
- 1 or 2 hp AC Drive Package with Inverter Duty Motor and Inverter Drive (up to 60 cpm)
- Varipak DC Motor Control (up to 30 cpm)
- Cycle Cam and Limit Switch Mounted to Camshaft
- Right Hand Cam

Output Load Capacity (loads carried during index):

- Radial 2,842 lbs
- Thrust/Axial 5,239 lbs
- Moment 2,959 in-lb

Accuracy ±36 arcsec / ±.001" at 6" Radius

Repeatability ±9 arcsec / ±.0003" at 6" Radius

Optional Accessories

- 1 hp DC motor
- 7350C Reducer (ratios from 5:1 to 60:1)
 - Motor Adapter and Coupling
- 2 hp DC Motor with Varipak DC Motor Control (up to 30 cpm)
- Output Overload Clutch Models: 11F, 11FC, 11FC-SD
 - Available Settings (in-lb): 2300, 4000, 6000, 8500, 11,000
- Dual Cycle Cam and Limit Switch
- Finished cover for ceiling mount or tooling plate mounting
- Left Hand Cam
- Relief in Dwell for shot-pin applications

Dimensions and technical information are subject to change without notice.



For more information or to place an order call 800-645-5207 or visit www.comoso.com or email camco@destaco.com

destaco.com

Rite-Link Series Product Overview, Technical Information

Right Sized Conveying

The **CAMCO Rite-Link Conveyor** is a thin-profile, preassembled, precision link system offering maintenance free accuracy and durability for industrial conveying applications.

- Precision positioning requiring higher precision or speed than roller chain can provide
- Material conveying (industrial or medical): for example, narrow cleat or bucket conveyor for constant speed applications. The conveyor can be mounted for either over/under or carousel operation

Features:

- Assembly
 - Fully designed, assembled and tested for your application
 - Can be used in an over/under or carousel configuration
- Size
 - Slim, compact design with narrow links accommodates oversized tooling
 - Easy to integrate
 - Servo-friendly for flexible indexing with CAMCO RSD rotary servo drive
- Accuracy
 - Precision motion from the trusted industry leader
 - More accurate and stable than roller chain
- Operation
 - High operation speeds
 - No lubrication needed
 - Energy efficient
 - Cost Effective



Maximum Load	Units	75RL...	115RL...	150RL...
Max Load per Link	kg	4	4	4
Max Overhung Load per Link	Nm	1.0	1.0	1.0

* shipping/clearance dimensions

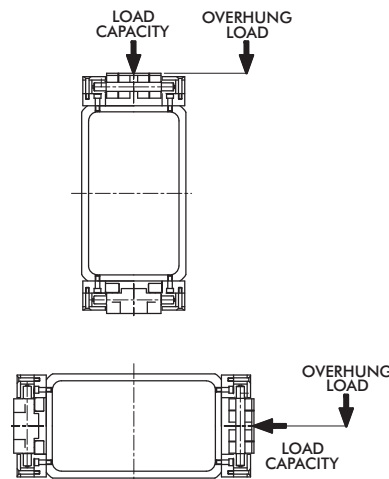

Dimensions and technical information are subject to change without notice.



Rite-Link Series Link Dimensions

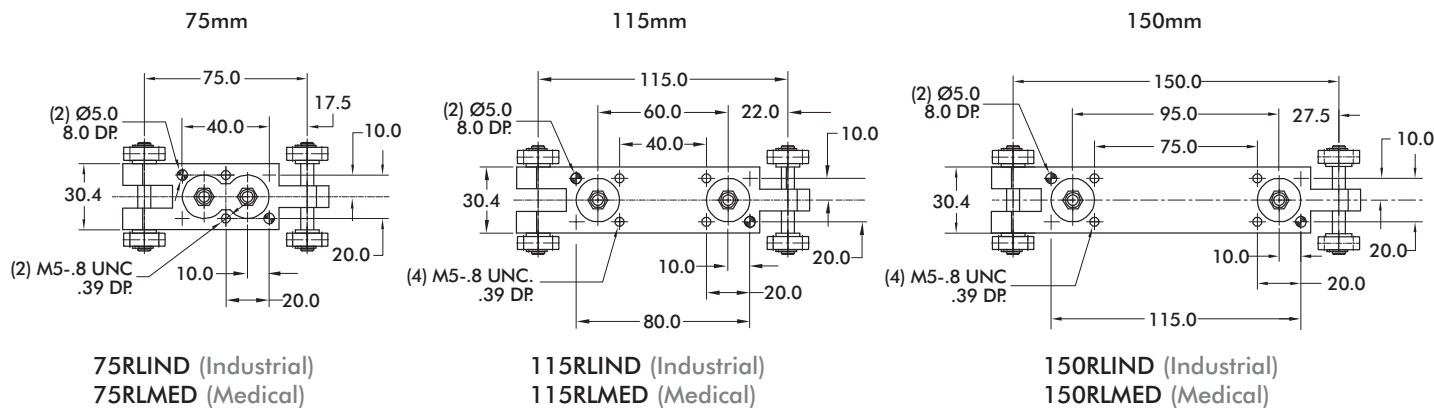

Rite-Link Series Standard Centers Dimensions

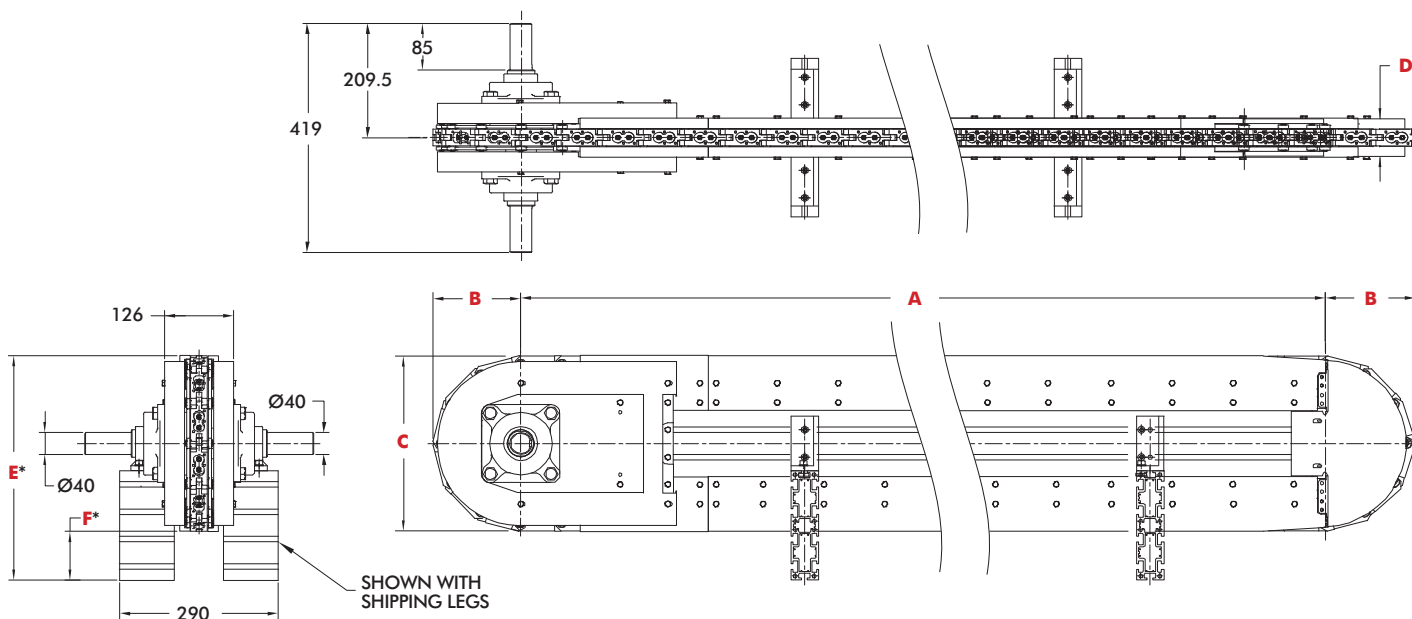

Rite-Link Series Technical Information

Dimensions	Units	75RL...	115RL...	150RL...
A Standard Center Distances				
Option 1	(meters)	1.20	1.38	1.20
Option 2		2.10	2.30	2.10
Option 3		3.00	3.22	3.00
Option 4		3.90	4.14	3.90
Option 5		4.80	5.06	4.80
B	mm	162.5	166	162.5
C	mm	320	332	332
D*	mm	78.1	78.1	78.1
E*	mm	411	466.2	416
F*	mm	89	133.8	84

* shipping/clearance dimensions

Dimensions and technical information are subject to change without notice.

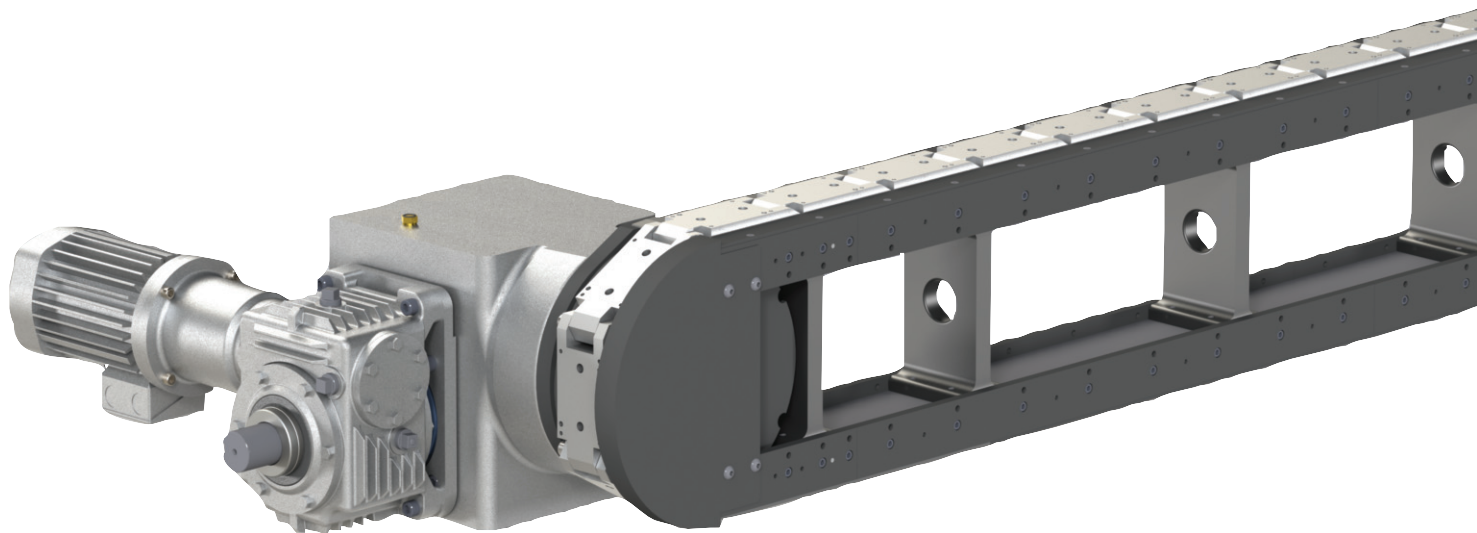

Features:

CAMCO Modular Table Top Precision Link Conveyors are ideal for linear transfer applications with features including:

- Modular frame design in fixed increment lengths facilitates quick assembly and delivery.
- Table-Top or Base mounted
- Available in carousel or over-under style
- Precision positioning of parts for assembly or manufacturing processes
- High-speed station-to-station parts transfer
- Precision links with roller bearing cam followers for smooth transfer and long life.
- Link sizes (3-inch, 4.5-inch, 6-inch) to meet most application requirements
- Open frame design for pass-through of belting, linkages, electric and air supply components.
- Optional bases, line shafts & tooling plates
- Complete with motorized index drive system including overload protection.

Table of Contents

3.0 Inch	162
4.5 Inch	164
6.0 Inch	166
Conveyor Options	168

Dimensions and technical information are subject to change without notice.



3.0 Inch Series Modular Conveyor (module only)

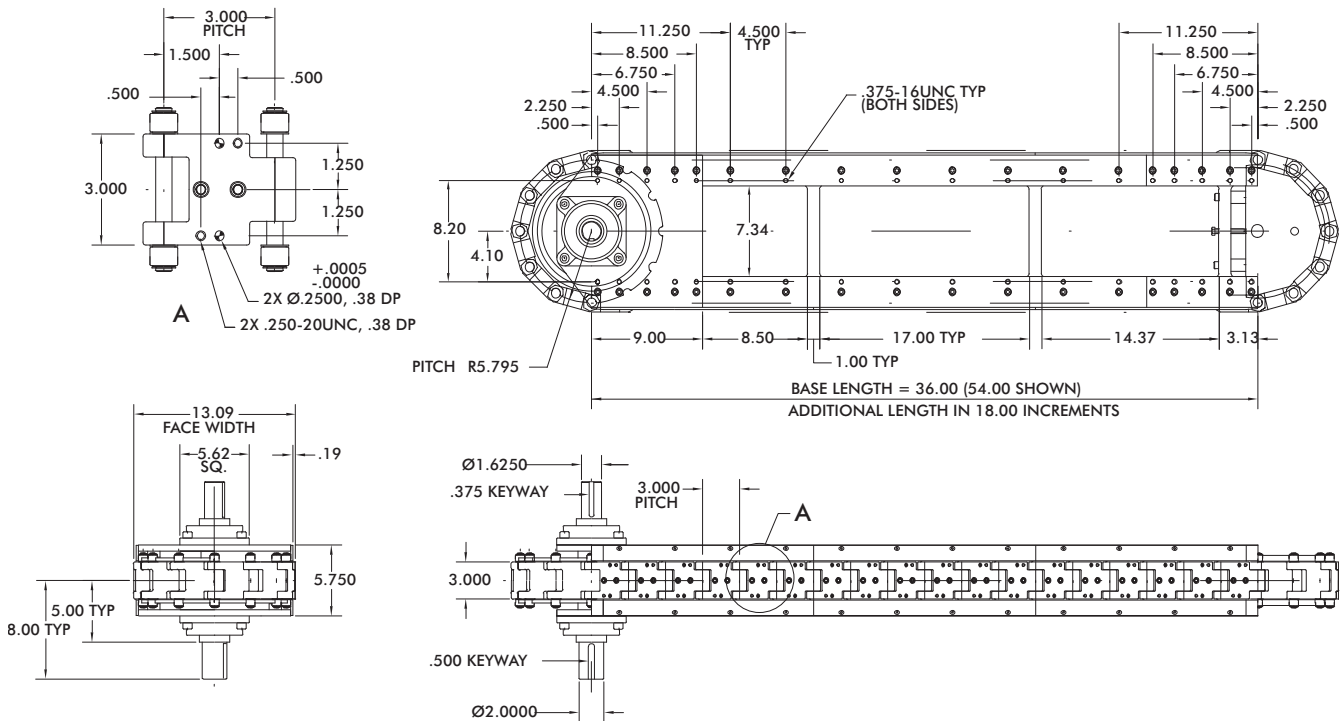

3.0 Inch Series Modular Conveyor (drive package)

Standard Drive Package

- 512RA Index Drive
- R225 Gear Reducer
- 6.0FC-SD Overload Clutch (Shaft Drive)
- 6.0S-SD Overload Clutch (Direct Drive)
- 1 hp high-cycling, performance AC Motor
- IM-pAC Motor Control

Heavy-Duty Drive Package

- 662RA Index Drive
- 7300C Gear Reducer
- 11FC-SD Overload Clutch (Shaft Drive)
- 6.0-SD Overload Clutch (Direct Drive)
- 1 hp high-cycling, performance AC Motor
- IM-pAC Motor Control

Index Distance [in.]	Indexer Stops
3.00	12
6.00	6
9.00	4
12.00	3

3.0 Inch Series Direct Drive Carousel

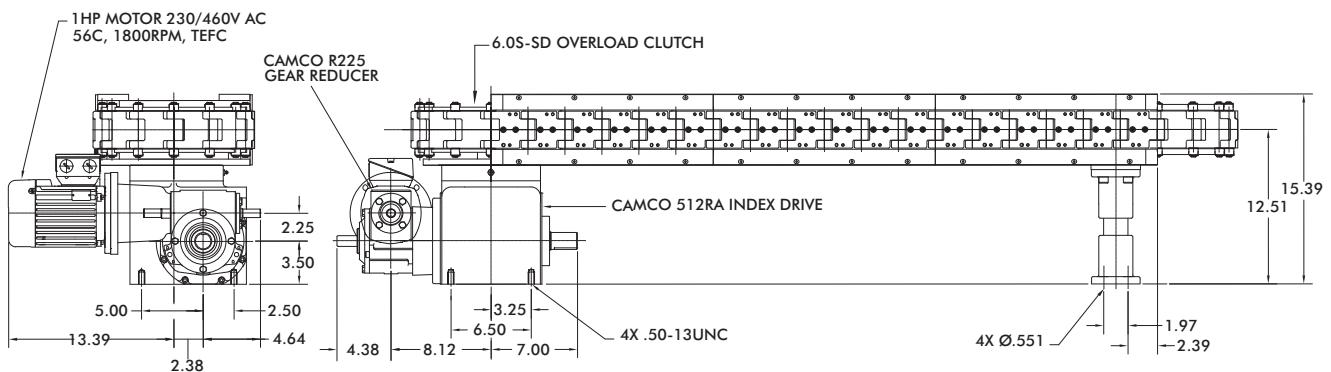

Dimensions and technical information are subject to change without notice.

3.0 Inch Series Shaft Drive Carousel

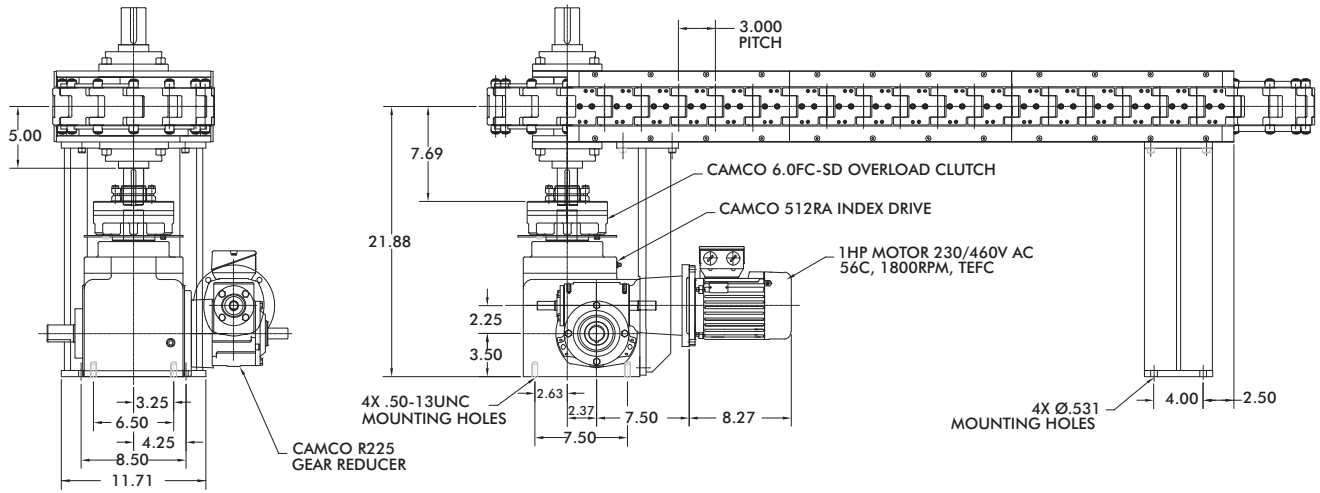

3.0 Inch Series Shaft Drive Over/Under

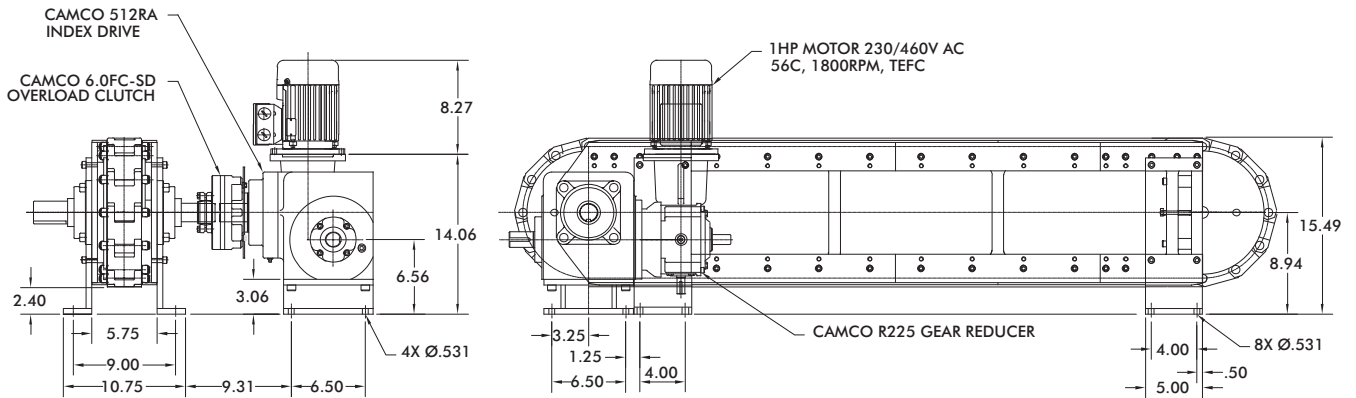

3.0 Inch Series Direct Drive Over/Under

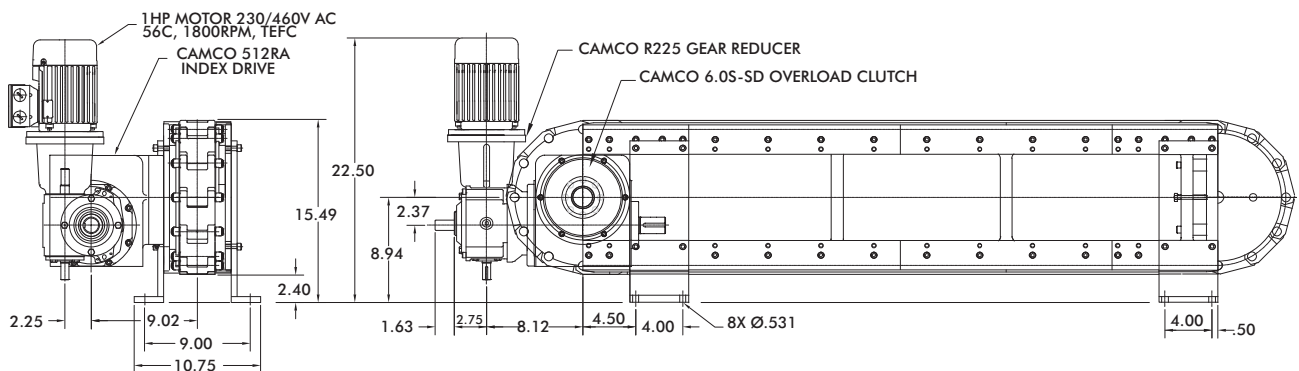

Dimensions and technical information are subject to change without notice.

4.5 Inch Series Modular Conveyor (module only)

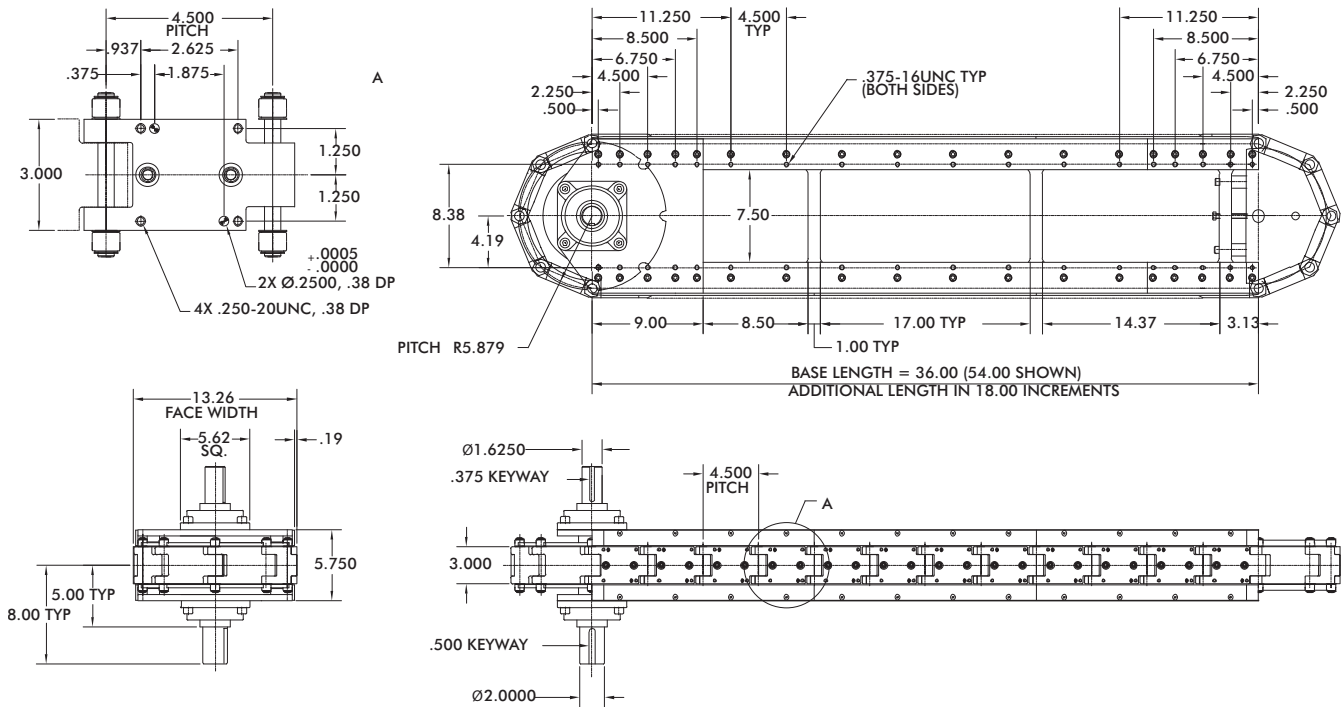

4.5 Inch Series Modular Conveyor (drive package)

Standard Drive Package

- 512RA Index Drive
- R225 Gear Reducer
- 6.0FC-SD Overload Clutch (Shaft Drive)
- 6.0S-SD Overload Clutch (Direct Drive)
- 1 hp high-cycling, performance AC Motor
- IM-pAC Motor Control

Heavy-Duty Drive Package

- 662RA Index Drive
- 7300C Gear Reducer
- 11FC-SD Overload Clutch (Shaft Drive)
- 6.0-SD Overload Clutch (Direct Drive)
- 1 hp high-cycling, performance AC Motor
- IM-pAC Motor Control

Index Distance [in.]	Indexer Stops
4.50	8
9.00	4
18.00	2

4.5 Inch Series Direct Drive Carousel

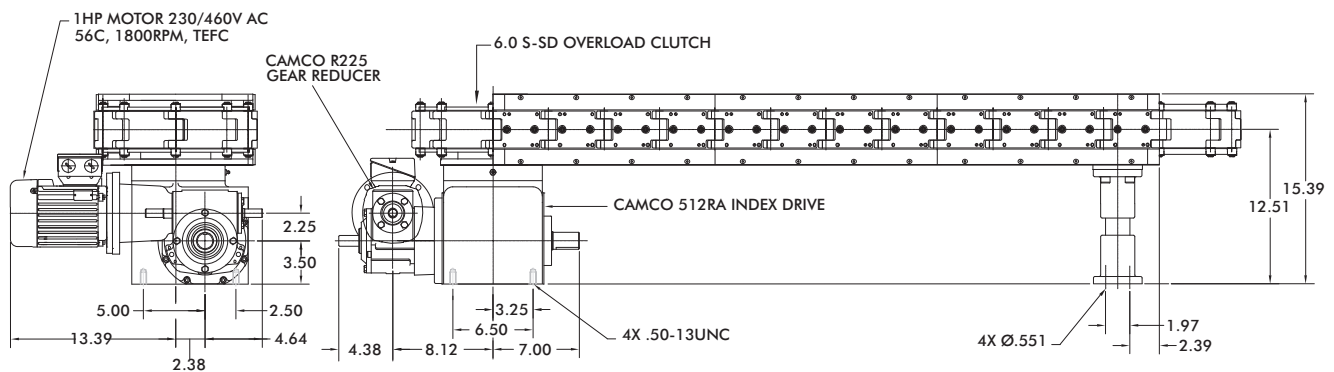

Dimensions and technical information are subject to change without notice.

4.5 Inch Series Shaft Drive Carousel

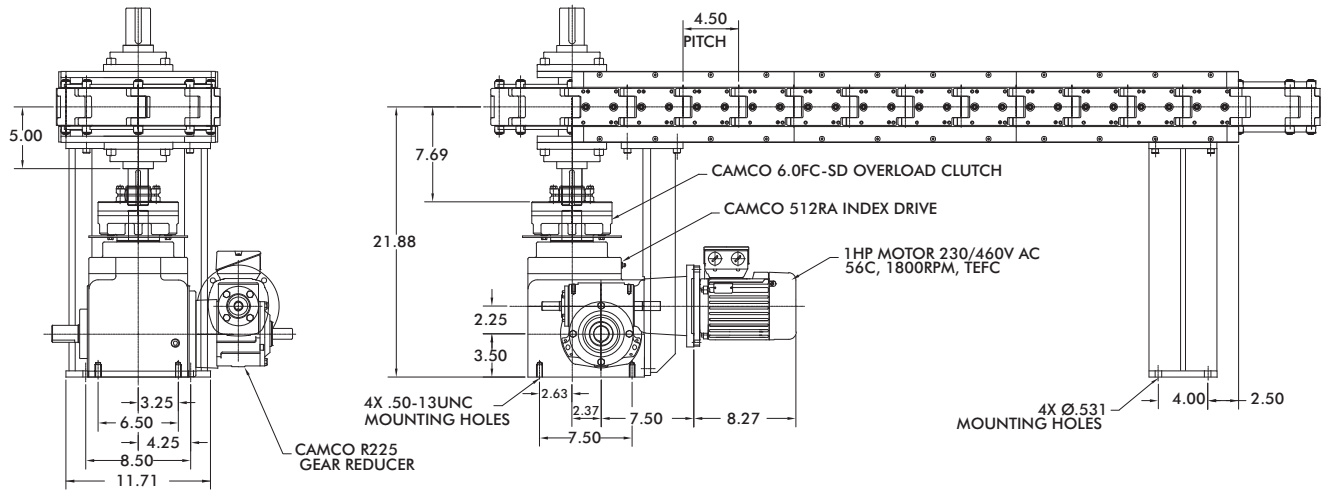

4.5 Inch Series Shaft Drive Over/Under

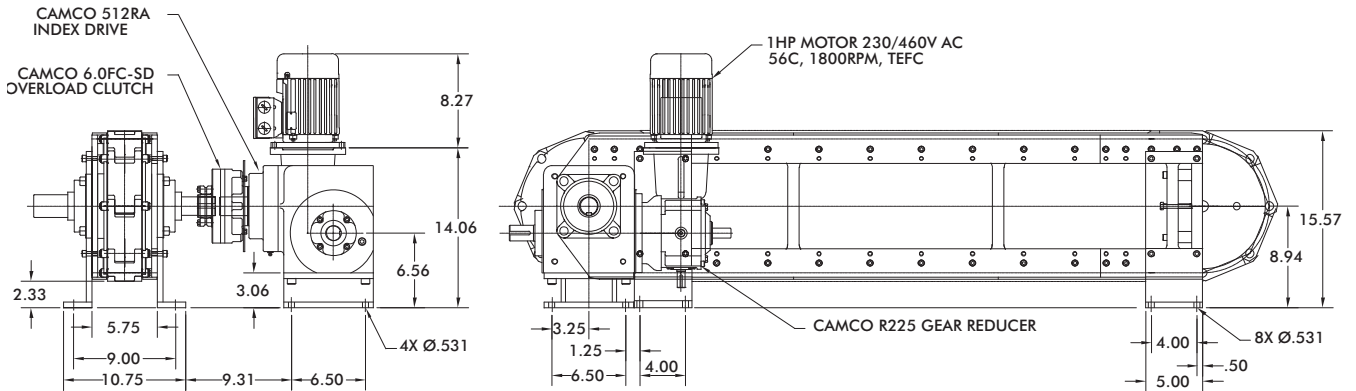

4.5 Inch Series Direct Drive Over/Under

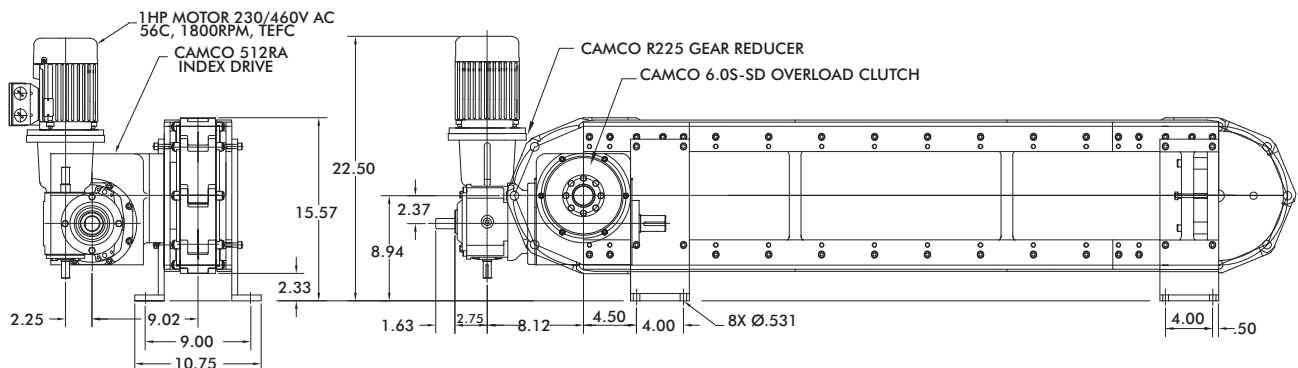

Dimensions and technical information are subject to change without notice.

6.0 Inch Series Modular Conveyor (module only)

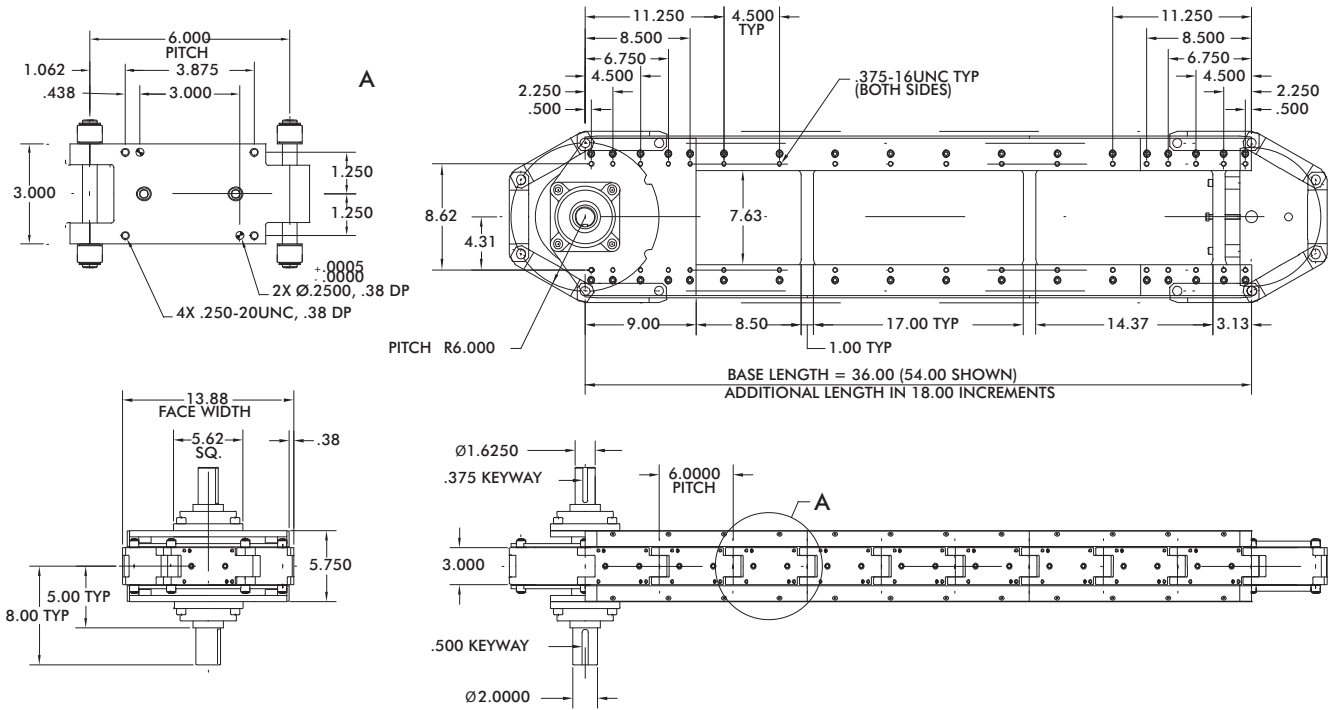

6.0 Inch Series Modular Conveyor (drive package)

Standard Drive Package

- 662RA Index Drive
- 7300C Gear Reducer
- 11FC-SD Overload Clutch (Shaft Drive)
- 6.0S-SD Overload Clutch (Direct Drive)
- 1 hp high-cycling, performance AC Motor
- IM-pAC Motor Control

Heavy-Duty Drive Package

- 800RD Index Drive
- 7300C Gear Reducer
- 25FC-SD Overload Clutch
- 1 hp high-cycling, performance AC Motor
- IM-pAC Motor Control

Index Distance [in.]	Indexer Stops
6.00	6
12.00	3
18.00	2

6.0 Inch Series Direct Drive Carousel

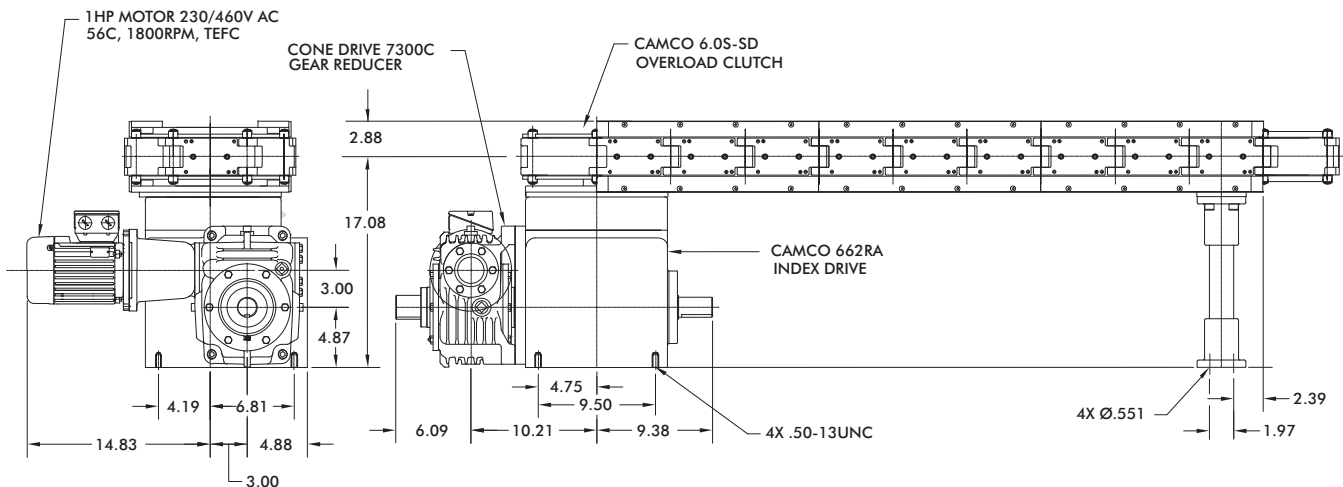

Dimensions and technical information are subject to change without notice.

6.0 Inch Series Shaft Drive Carousel

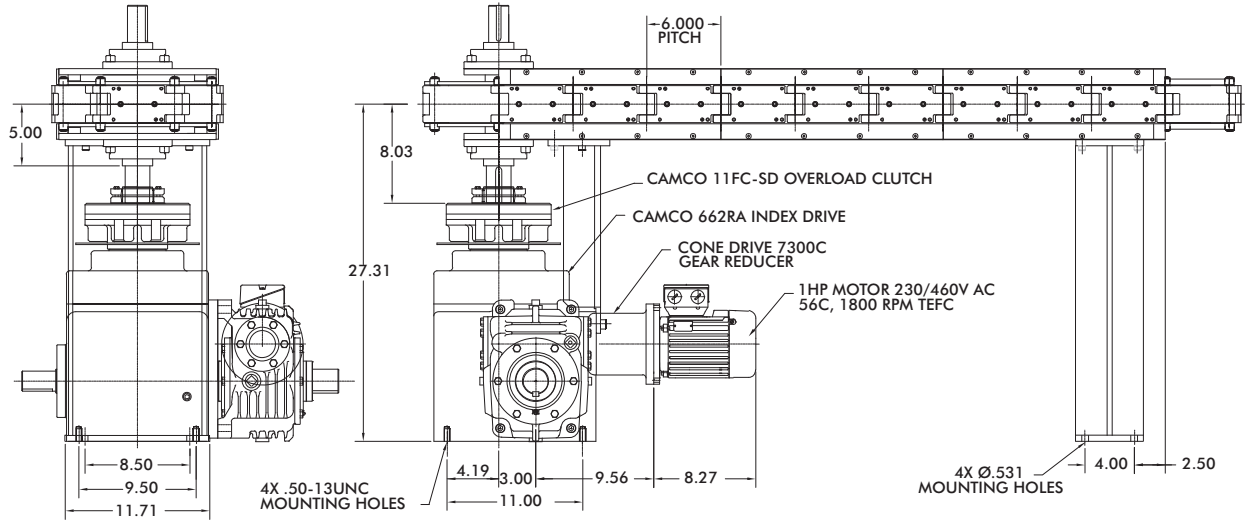

6.0 Inch Series Shaft Drive Over/Under

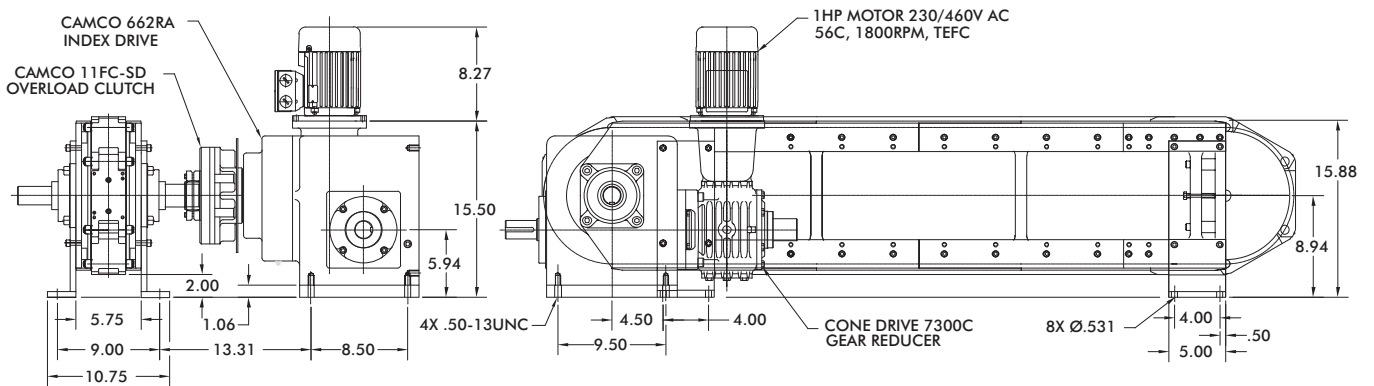

6.0 Inch Series Direct Drive Over/Under

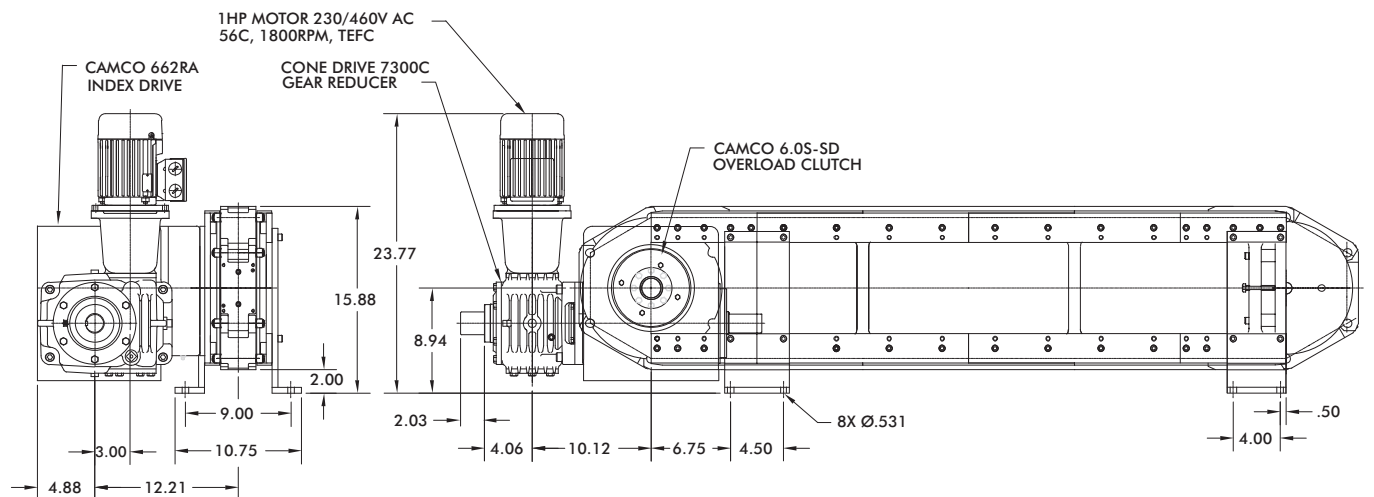

Dimensions and technical information are subject to change without notice.

Conveyor Type

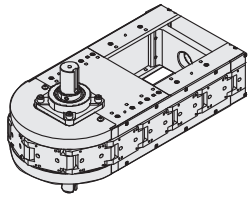

MODULE ONLY

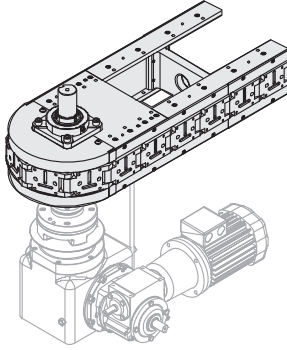

CAROUSEL-SHAFT DRIVEN

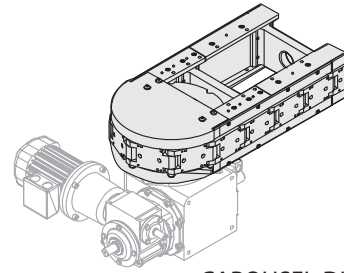

CAROUSEL-DIRECT DRIVEN

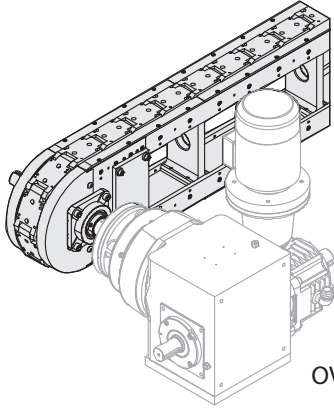

OVER-UNDER SHAFT DRIVEN

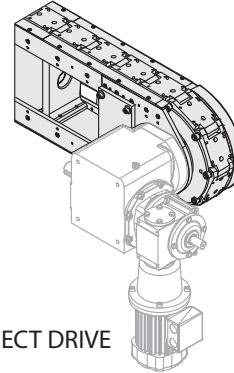

OVER-UNDER DIRECT DRIVE

Carousel Indexer Position

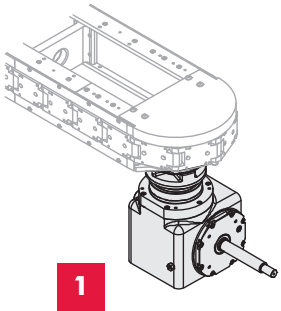

1

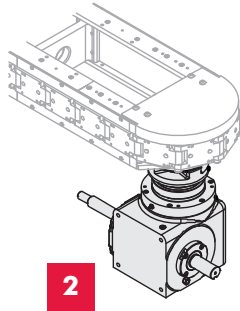

2

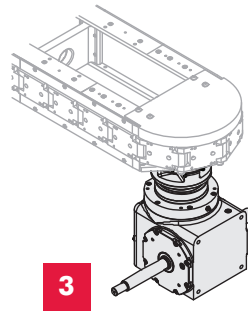

3

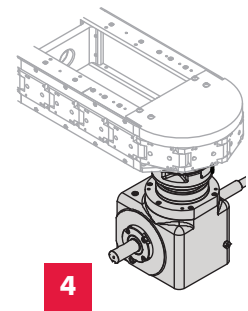

4

Over/Under Side

DRIVE - SIDE 1

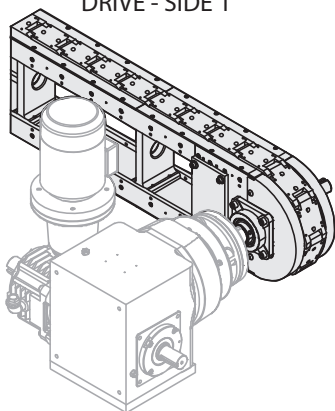

DRIVE - SIDE 2

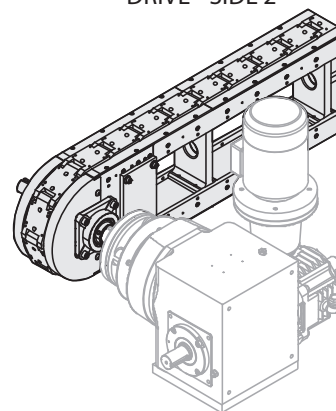

Dimensions and technical information are subject to change without notice.

Tooling Plate Options Carousel

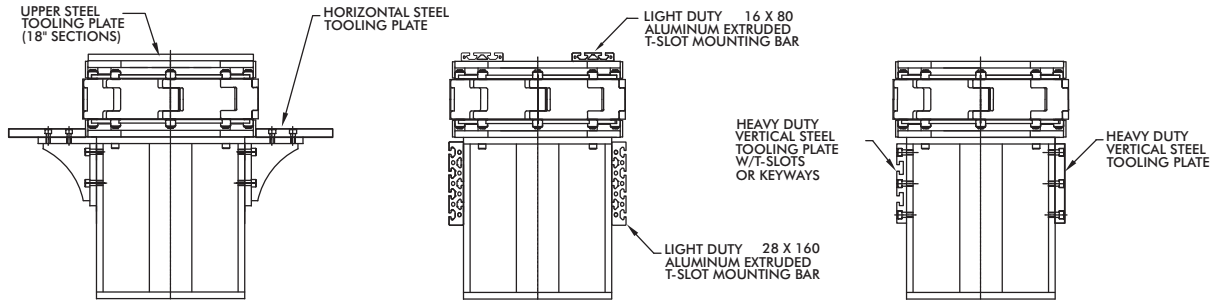

Tooling Plate Options Over/Under

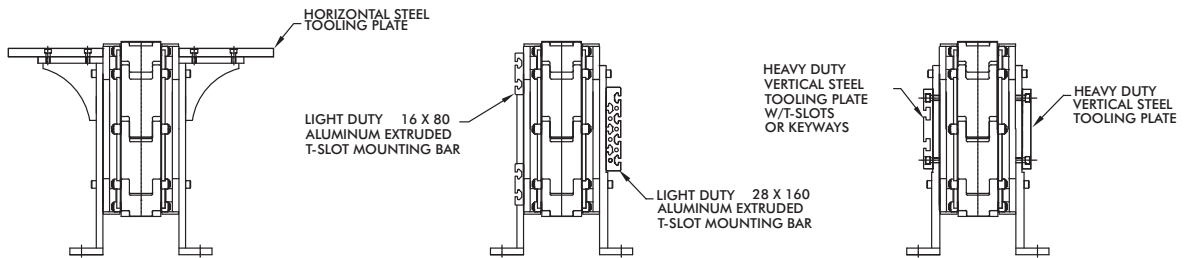

Support Leg Options

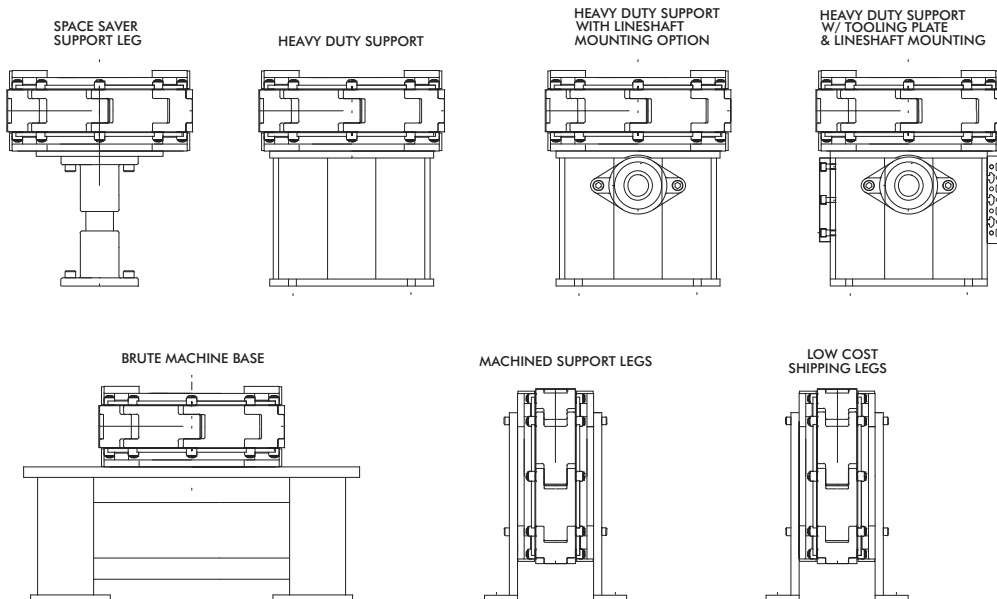

Dimensions and technical information are subject to change without notice.

Lower Lineshaft Options Belt Driven

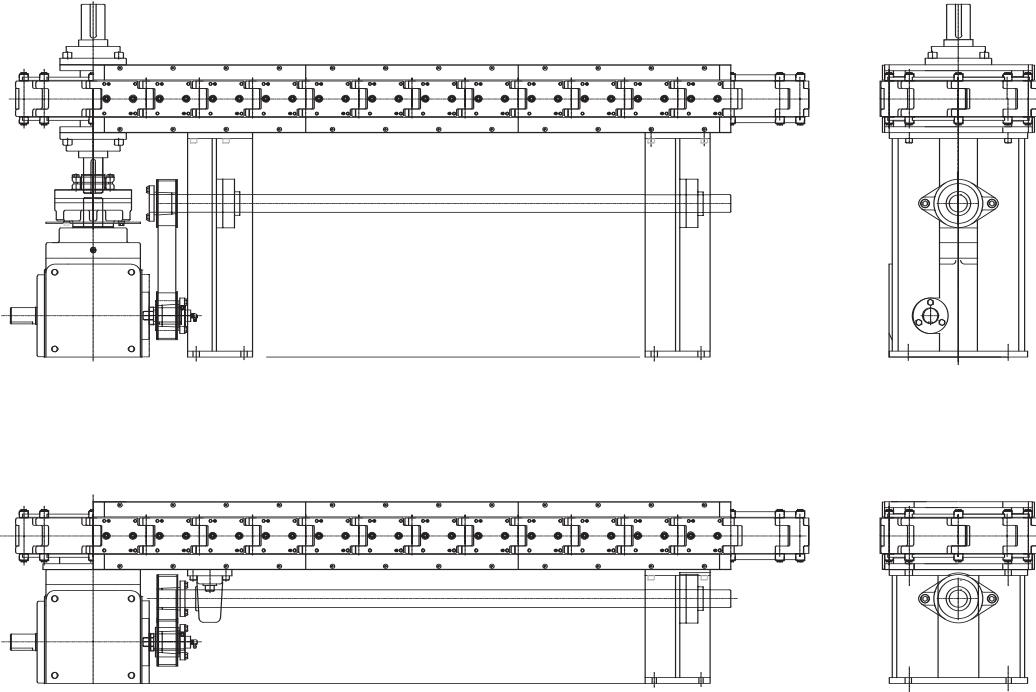

Lower Lineshaft Options Direct Driven

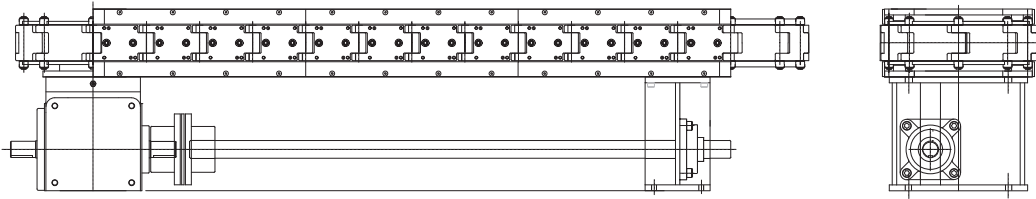

Drive Side Lineshaft Options Belt Driven

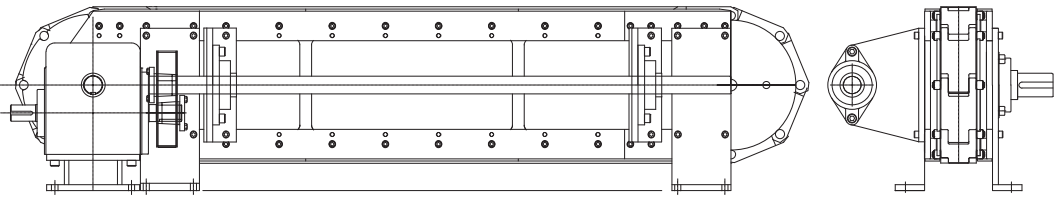

Drive Side Lineshaft Options Direct Driven

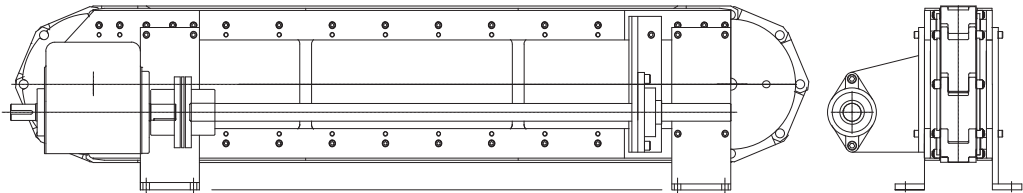

Dimensions and technical information are subject to change without notice.

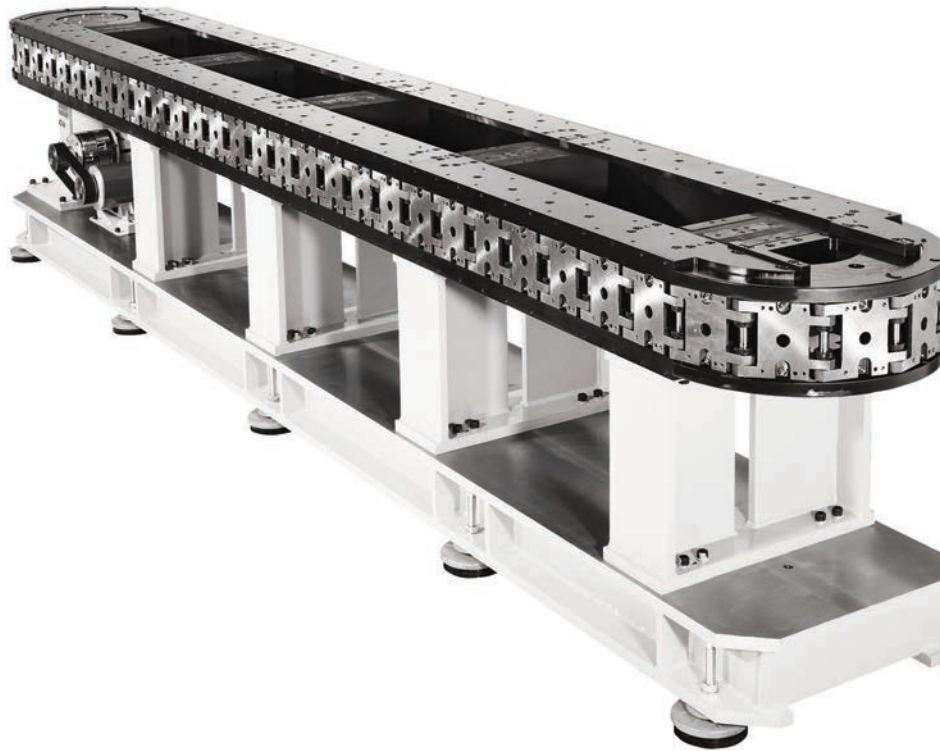

Features:

CAMCO Heavy Duty Precision Link Conveyors combine excellent accuracy with high load capacity to provide the versatility needed to meet virtually any automated assembly or manufacturing challenge.

- Standard link lengths of 6.0", 9.0" and 12"
- Over/Under and Carousel configurations
- Precision links with roller bearing cam followers for smooth transfer and long life
- Provided with heavy-duty legs and a precision machined base designed to hold large loads and maintain system accuracy
- Available with adjustable soft machine mounts to accommodate inconsistent on-site flooring
- Customize length and height and add optional line shafts or tooling plates to fit your application

Table of Contents

How to Order172

Conveyor Options173

6.0 Inch Heavy Duty174

9.0 Inch Heavy Duty176

12.0 Inch Heavy Duty178

Dimensions and technical information are subject to change without notice.



Heavy-Duty Precision Link Conveyors Series How to Order

Required Information

- **Link Size:** 1.5, 2.0, 3.0, 4.5, 6.0, 9.0 or 12.0
- **Type:** Table Top or Heavy Duty
- **Style:** Over/Under or Carousel
- **Length:** Standard per catalog or Custom, expressed as center distance, in inches
- **Height:** Standard per catalog or Custom, in inches

Required Information when ordering Drive Package

- **Type:** Standard, Alternate, Heavy-Duty or Special
- **Drive Side:** 1 or 2 (for Over/Under)
- **Index Distance:** In inches
- **Indexer Model:** Specific model number or special

Technical Assistance

All Precision Link Conveyor applications are verified by a IMC sales agent using the IMC Sizing Program.

Your IMC agent is available to make all sizing calculations for you.

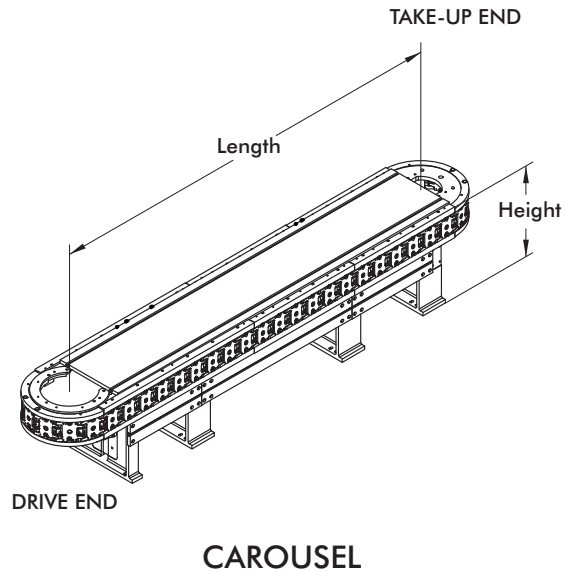
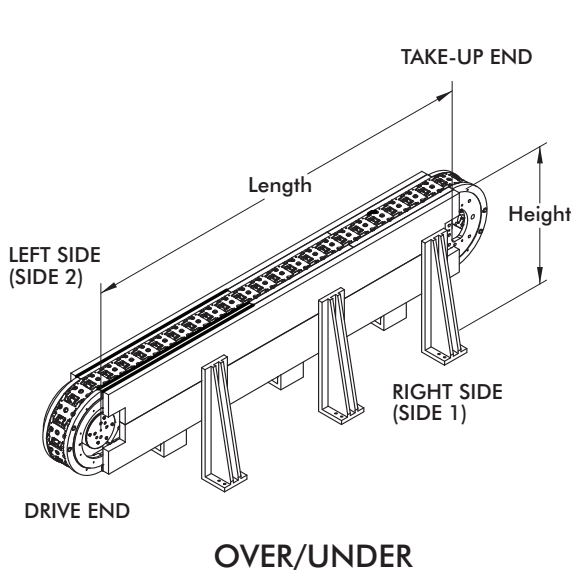

Dimensions and technical information are subject to change without notice.

Heavy Duty Precision Link Conveyors Options

CAMCO offers a wide variety of standard and custom options on all precision link conveyors. Tooling plates and conveyor mainframes can be ordered with custom hole configurations or burnouts. Other standard options include timing chains, timing belts and extended lineshafts. Standard drive package options include CAMCO indexers with AC motors and clutch-brakes, DC motors or servo motors. CAMCO's special Indexer output overload clutches are highly recommended to protect the indexer, link assembly and tooling.

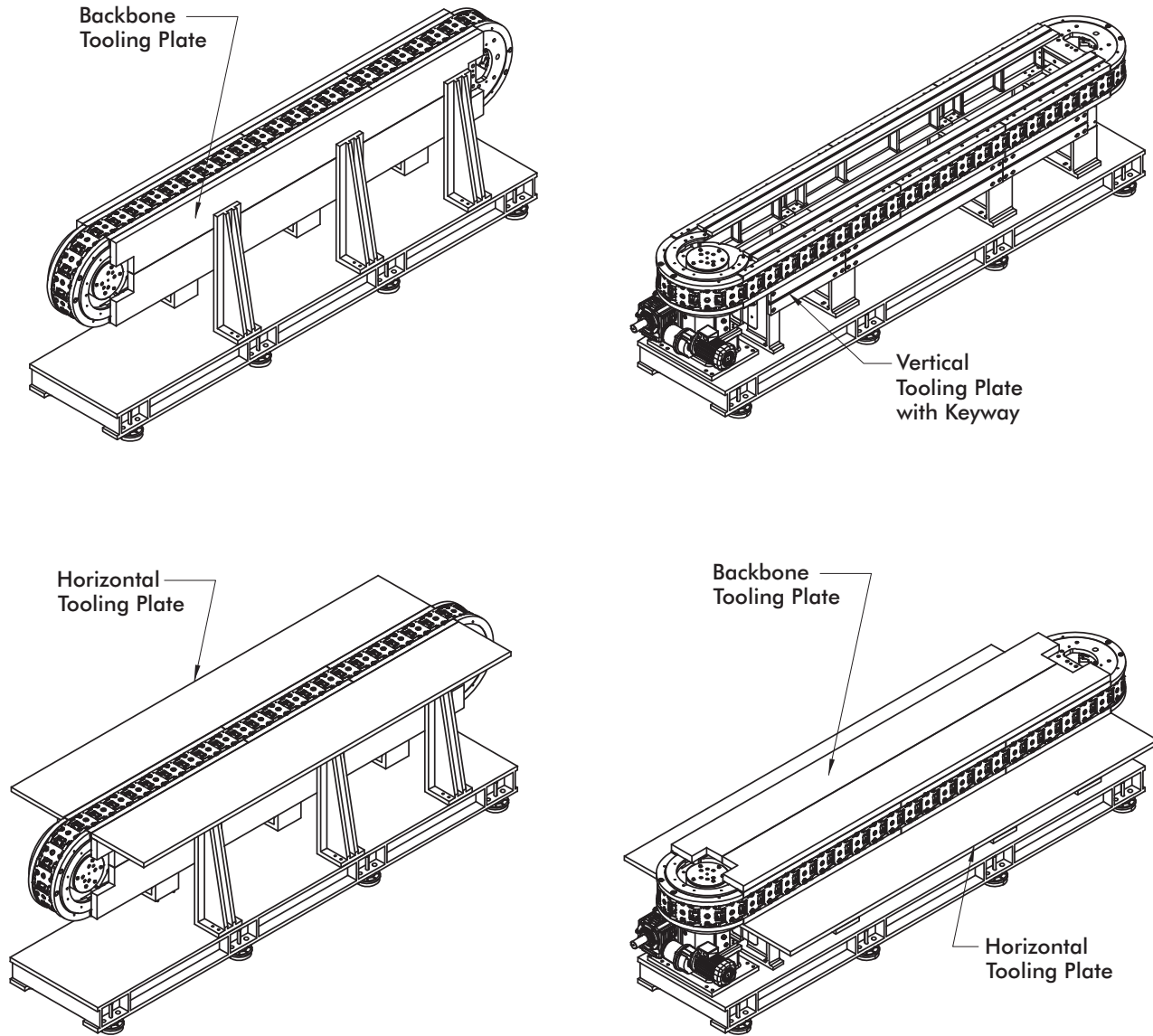

Using Cambot Parts Handlers with Precision Link Conveyors

Cambot linear pick-and-place parts handlers have custom cam motions incorporated into each unit, providing complex synchronize timings for your application. They can be mounted onto the backbone tooling plates of the conveyor. Cambot linear pick-and-place parts handlers can be belt driven off a common line shaft for perfect synchronization. See the Rotary Parts Handler section (page 181) for other possible configurations, such as a rotary pick-and-place device loading parts from a continuous line conveyor to a CAMCO index drive conveyor.

Dimensions and technical information are subject to change without notice.

6.0 Inch Heavy Duty Series Link

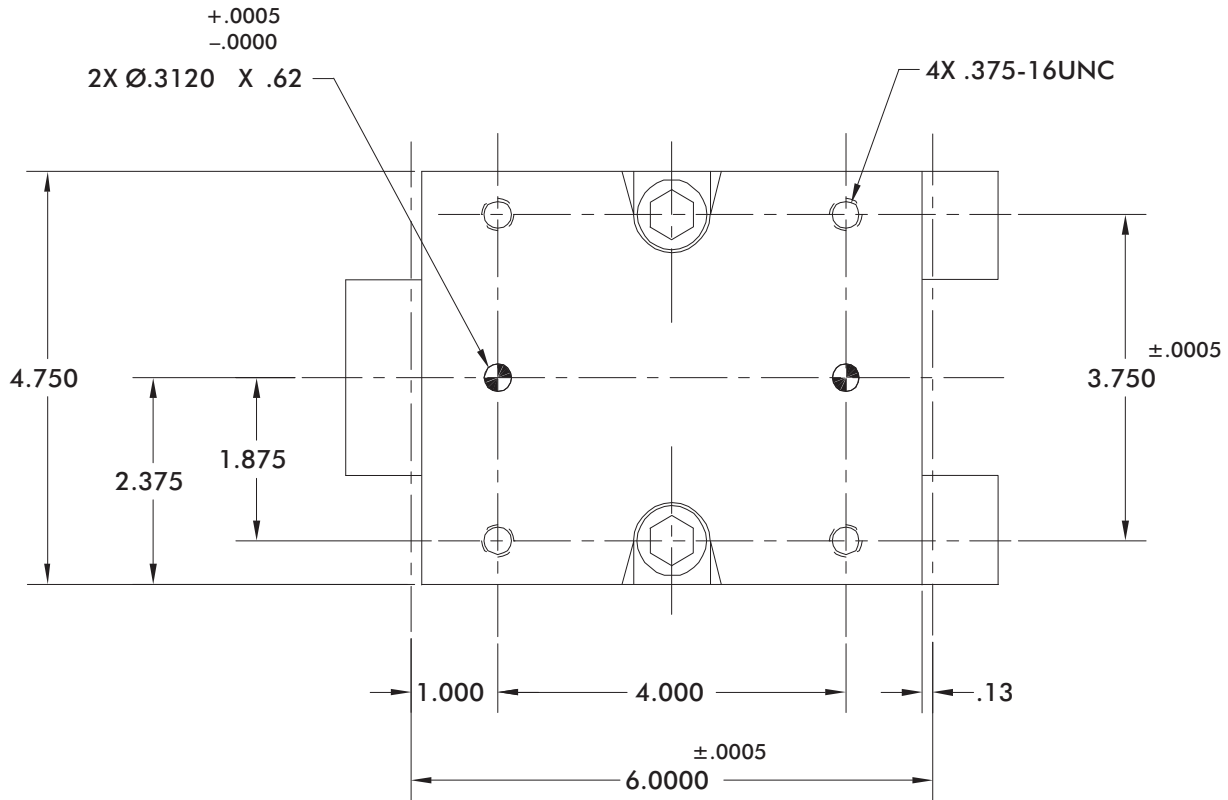

6.0 Heavy Duty Inch Series Modular Conveyor (drive package)

Standard Drive Package

- 1301RD Intermittor
- 73500C Reducer
- 5 hp AC Motor
- MDB-1125 Air Clutch-Brake
- Cycle Cam & Limit Switch

Index Distance [in.]	Indexer Stops
6.00	12
12.00	6
18.00	4
24.00	3

Dimensions and technical information are subject to change without notice.

6.0 Heavy Duty Inch Series Carousel

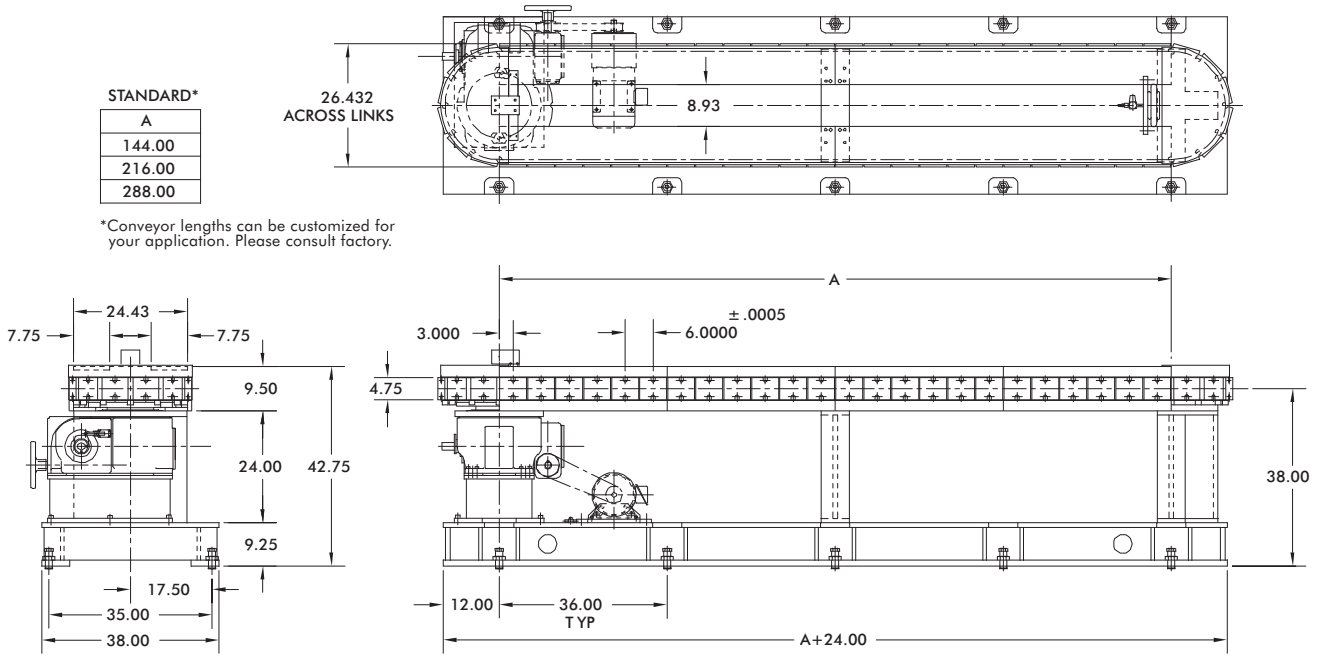

6.0 Heavy Duty Inch Series Over/Under

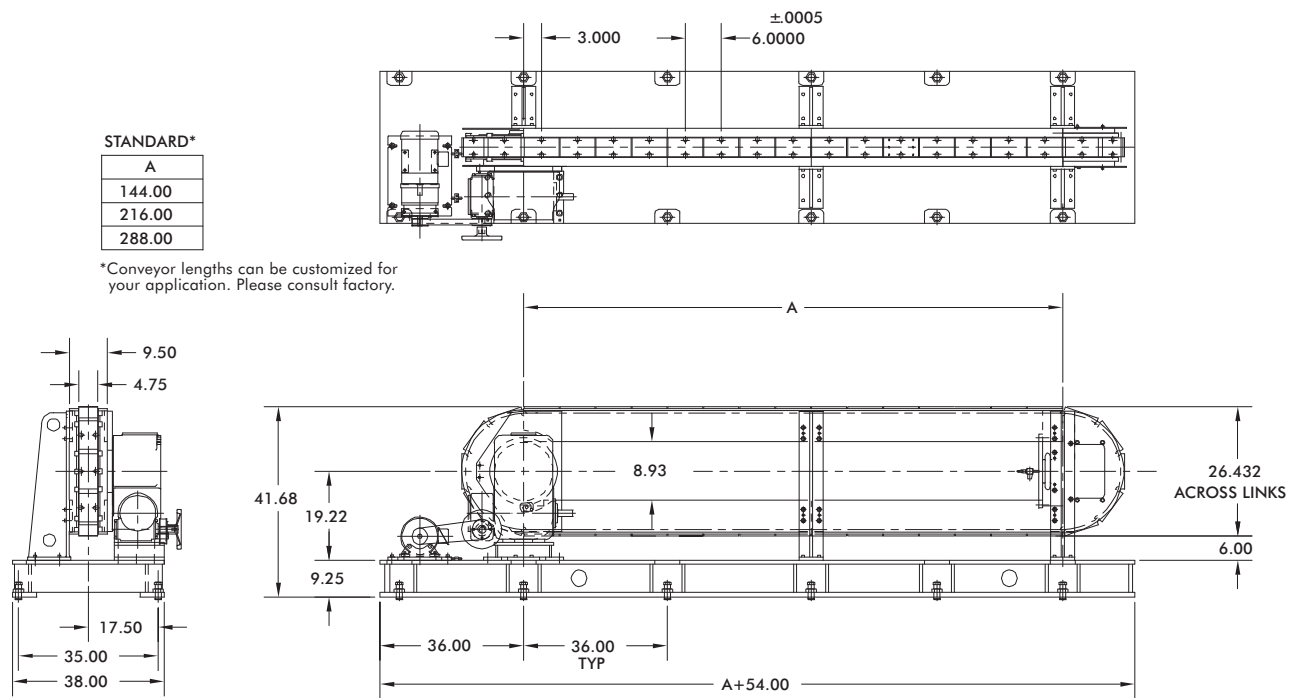

Dimensions and technical information are subject to change without notice.

9.0 Inch Heavy Duty Series Link

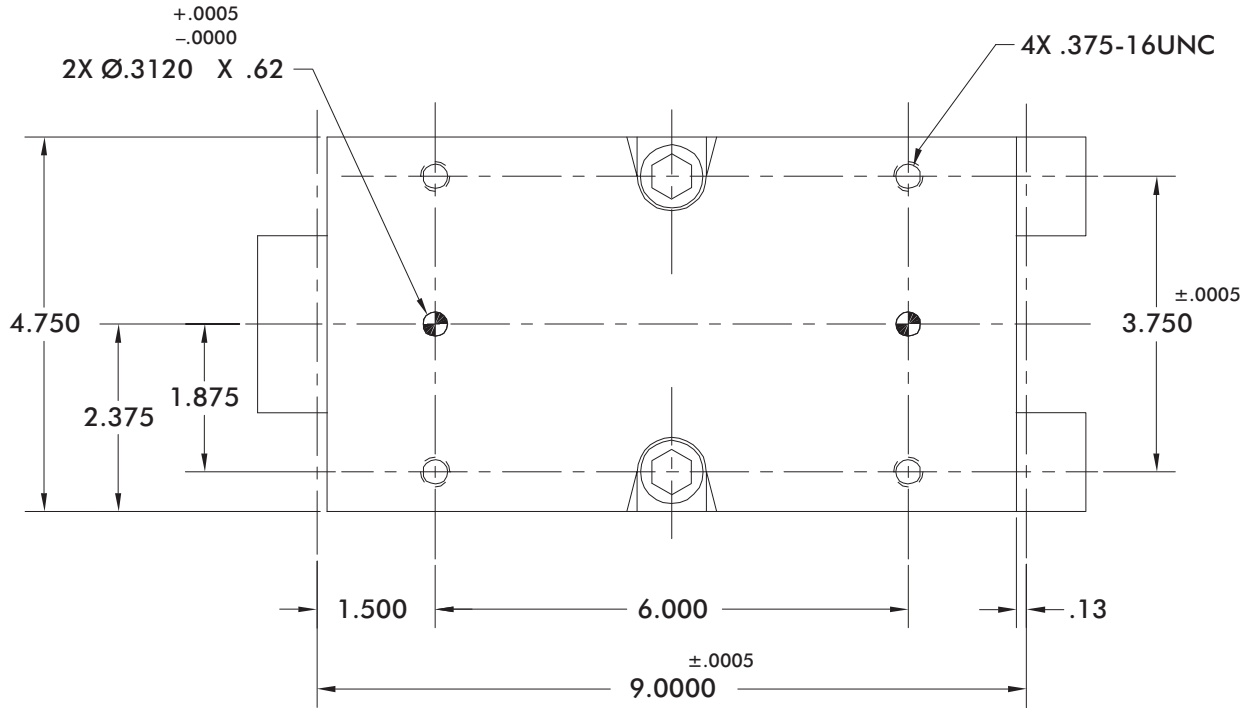

9.0 Inch Heavy Duty Series Modular Conveyor (drive package)

Standard Drive Package

- 1301RD Intermittor
- 73500C Reducer
- 5 hp AC Motor
- MDB-1125 Air Clutch-Brake
- Cycle Cam & Limit Switch

Index Distance [in.]	Indexer Stops
9.00	12
18.00	6
27.00	4
36.00	3

Dimensions and technical information are subject to change without notice.

9.0 Inch Heavy Duty Series Carousel

STANDARD*

A
144.00
216.00
288.00

*Conveyor lengths can be customized for your application. Please consult factory.

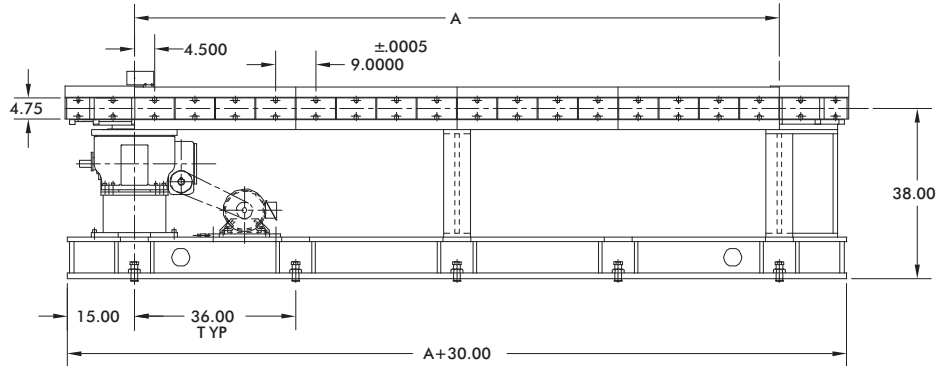
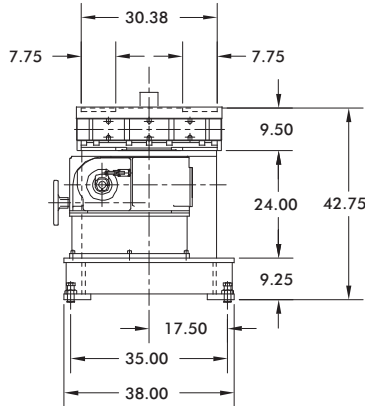
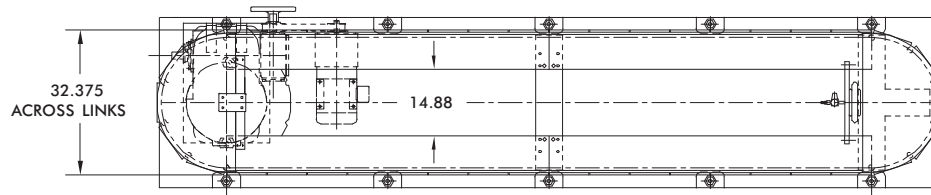

CONVEYOR SHOWN WITH 10-TOOTH SPROCKET

9.0 Inch Heavy Duty Series Over/Under

STANDARD*

A
144.00
216.00
288.00

*Conveyor lengths can be customized for your application. Please consult factory.

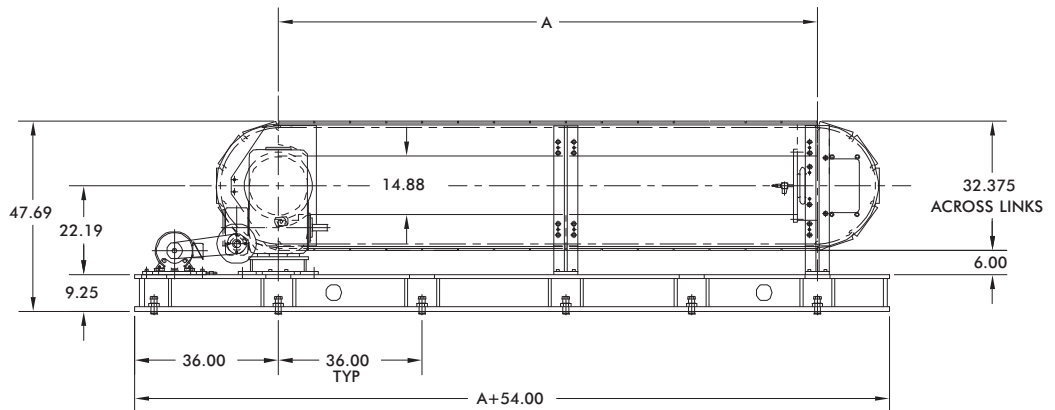
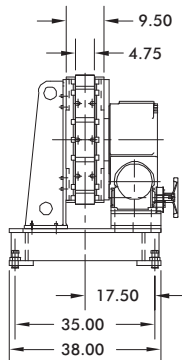
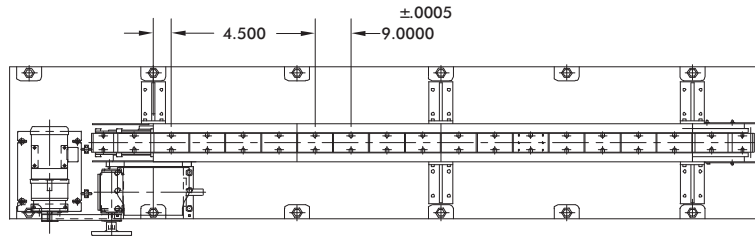

CONVEYOR SHOWN WITH 10-TOOTH SPROCKET

Dimensions and technical information are subject to change without notice.

12.0 Inch Heavy Duty Series Link

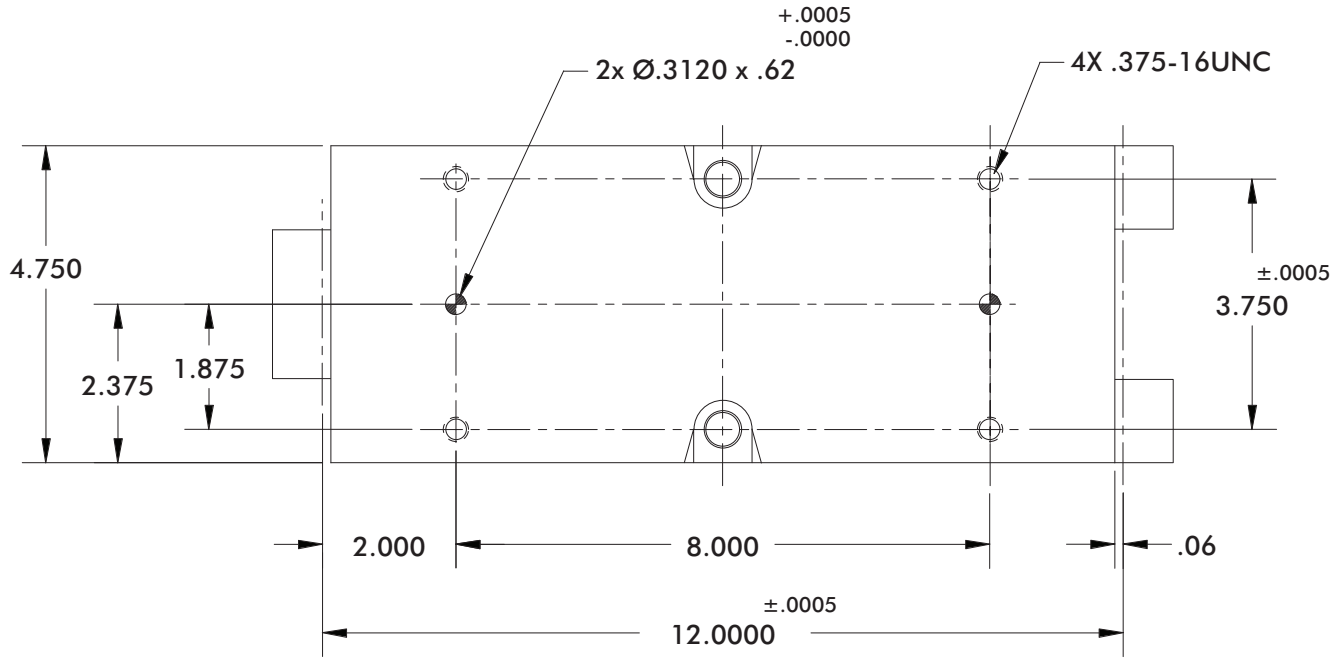

12.0 Inch Heavy Duty Series Modular Conveyor (drive package)

Standard Drive Package

- 1301RD Intermittor
- 7500C Reducer
- 5 hp AC Motor
- MDB-1125 Air Clutch-Brake
- Cycle Cam & Limit Switch

Index Distance [in.]	Indexer Stops	Sprocket
12.00	8, 10, 12	8T, 10T, 12T
24.00	4, 5, 6	8T, 10T, 12T
36.00	4	12T
48.00	2, 3	8T, 12T

Dimensions and technical information are subject to change without notice.

12.0 Inch Heavy Duty Series Carousel

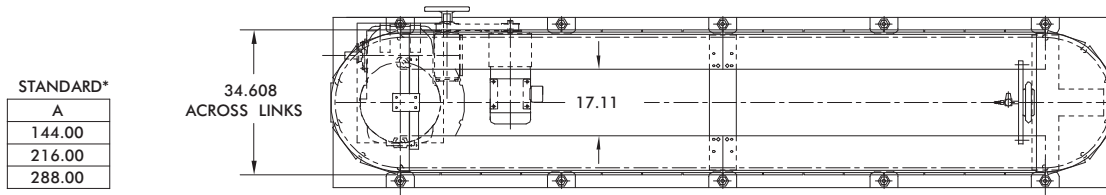

*Conveyor lengths can be customized for your application. Please consult factory.

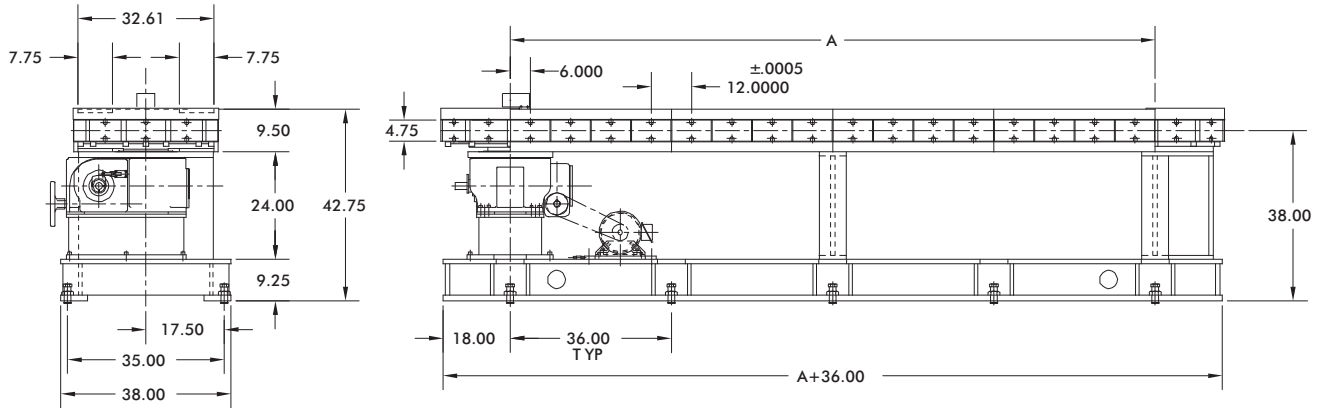

12.0 Inch Heavy Duty Series Over/Under

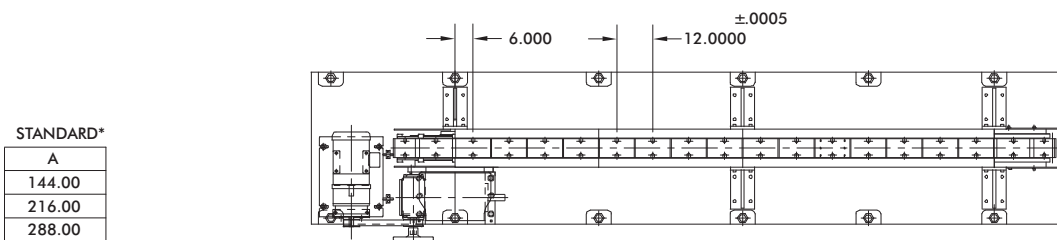

*Conveyor lengths can be customized for your application. Please consult factory.

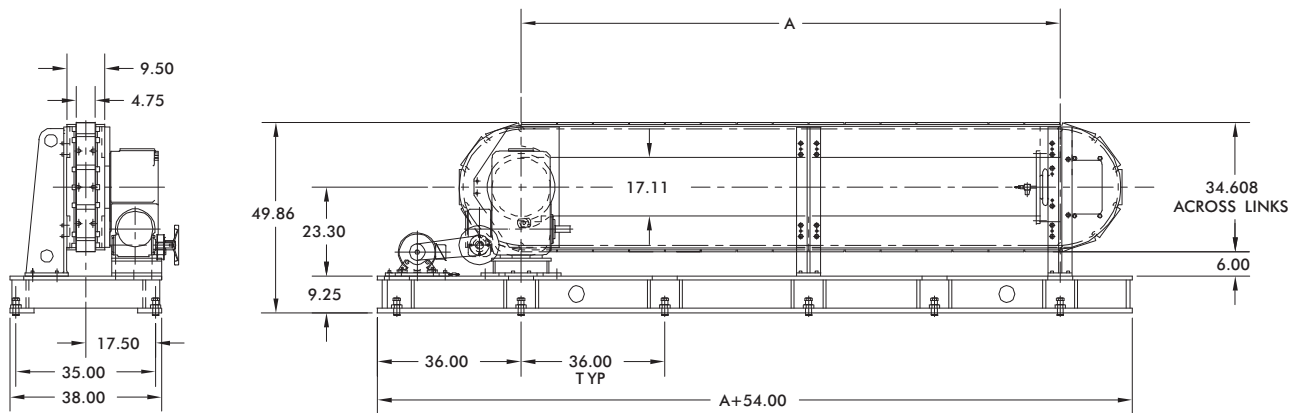

Dimensions and technical information are subject to change without notice.



Notes

Large grid area for notes.

Dimensions and technical information are subject to change without notice.



LPP Series Linear Parts Handler

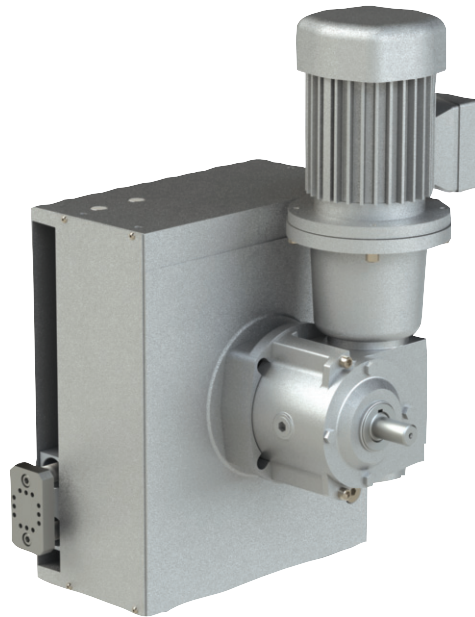

Features:

CAMCO Cambot® Linear Parts Handlers, combined with other DE-STA-CO products, offer a low maintenance, cost-effective solution for a complete parts handling package.

- Cost effective design for low-cost operation
 - Reliable CAMCO mechanical cam design
 - Lubed for Life
- Easy integration with other DE-STA-CO products for one-stop shopping
 - Camco Modular Precision Link Conveyors and Ring Drives
 - DE-STA-CO Vacuum products
 - Robohand Direct Connect™ Grippers (no adapter plates) and E-Gripper
- Customized for your application
 - Input shaft available on either side for ease of integration
 - Line shaft drive or gear reducer and motor drive package for synchronous or asynchronous operation
- Standard or custom strokes and timing designed for your specific requirements

Applications:

Automated production systems with small parts transfer such as consumer products, electronics, and medical device assembly and test.

Table of Contents

How to Order	182
M100/M150	184
Gripper Mounting Accessory	186

Dimensions and technical information are subject to change without notice.



LPP Series How to Order

LPP Ordering Procedure

1. Model
2. Lift (Vertical) Stroke
3. Transfer (Horizontal) Stroke

Standard Strokes: Lift (mm) x Transfer (mm)	
M100	M150
15 x 100	15 x 150
45 x 100	45 x 150
65 x 20	75 x 50
65 x 60	75 x 110
65 x 100	75 x 150

4. Output Sequence (Standard or Custom)

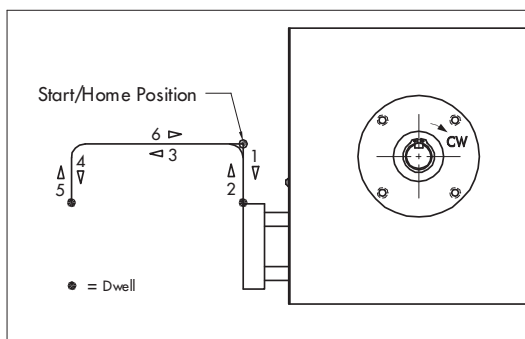

5. Drive Page including Gear Reducer, Motor, and AC Drive

Model	Gear Reducer	AC Motor	1 hp AC Drive Input Voltage (select 1)		
M100	R180	1/3 hp	120 VAC	240 VAC	480 VAC
M150	R225	3/4 hp	120 VAC	240 VAC	480 VAC

Dimensions and technical information are subject to change without notice.

Mounting Position

OHUI (output horizontal, under input)	OHOI (output horizontal, over input)	OHID (output horizontal, input down)	OHIU (output horizontal, input up)	VU (output vertical up)	VD (output vertical down)
 1	 2	 3	 4	 5	 6

Gear Reducer Mounting Positions

		Mounting "A"		Mounting "B"	
		RH	LH	RH	LH
SIDE 1	 A	 B	 C	 D	
	SIDE 2	 E	 F	 G	 H
		Mounting "C"		Mounting "D"	
		RH	LH	RH	LH
SIDE 1	 J	 K	 L	 M	
	SIDE 2	 N	 P	 R	 S

Dimensions and technical information are subject to change without notice.

M100/M150 Standard Dimensions, Technical Information

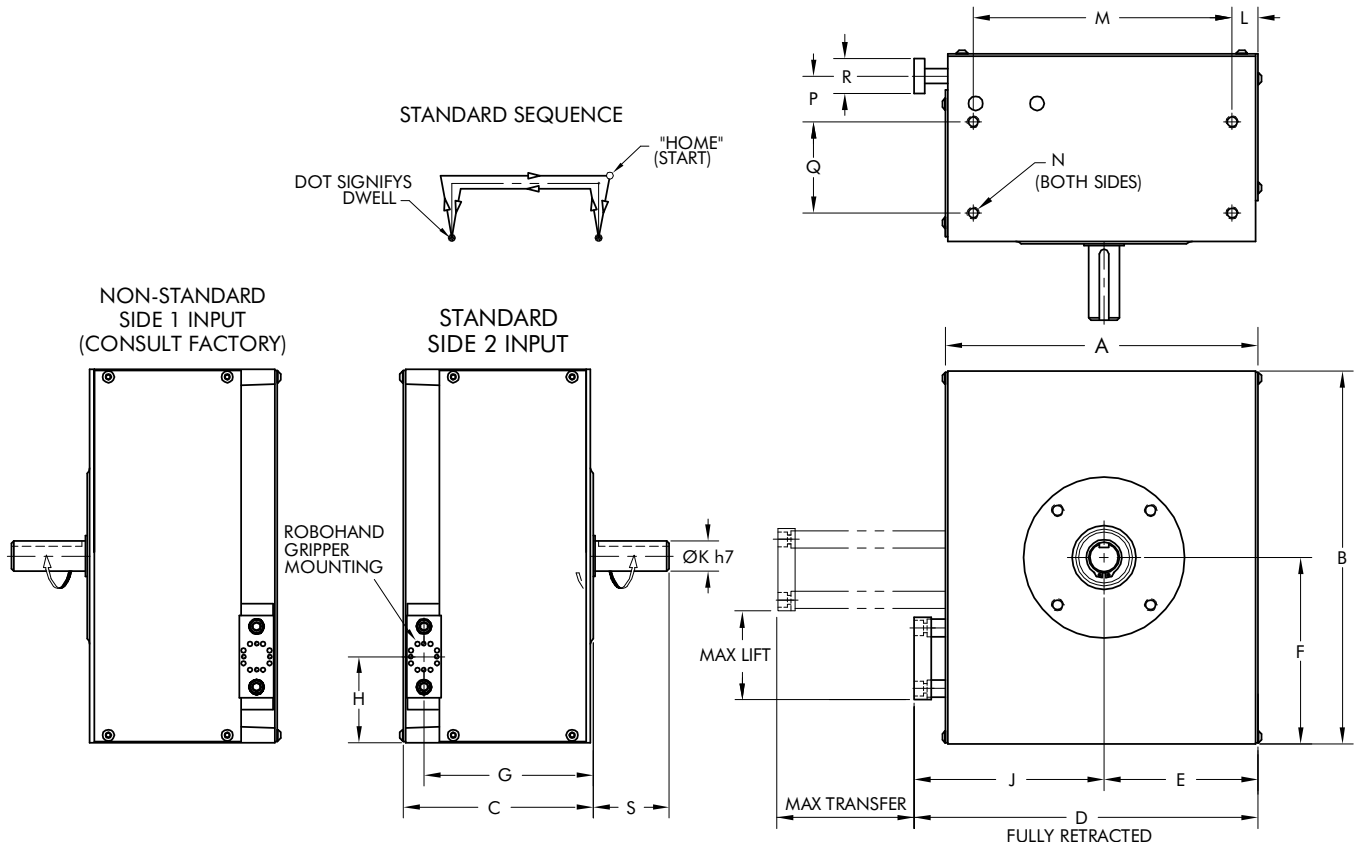

Model	A	B	C	D	E	F	G	H	J	K	L	M	N	P	Q	R	S
M100	251	290	145	279.7	123	145	130	65	157	25	12	225	4 x M8	40	65	25.4	50
M150	332	400	170	366	160	200	148	90	206	30	15	300	4 x M10	40	80	51	55

Technical Specifications				
Model	Maximum Lift	Maximum Transfer	Capacity at 30 rpm	Capacity at 60 rpm
M100	65 mm	100 mm	8 kg (18 lbs)	3.6 kg (8 lbs)
M150	75 mm	150 mm	18 kg (40 lbs)	9 kg (20 lbs)

Model	Lift		Transfer	
	Accuracy	Repeatability	Accuracy	Repeatability
M100	±.13 mm (±.005")	±.03 mm (±.001")	±.08 mm (±.003")	±.03 mm (±.001")
M150	±.20 mm (±.008")	±.08 mm (±.003")	±.08 mm (±.003")	±.03 mm (±.001")

Dimensions and technical information are subject to change without notice.

Gripper Mounting Block Accessories

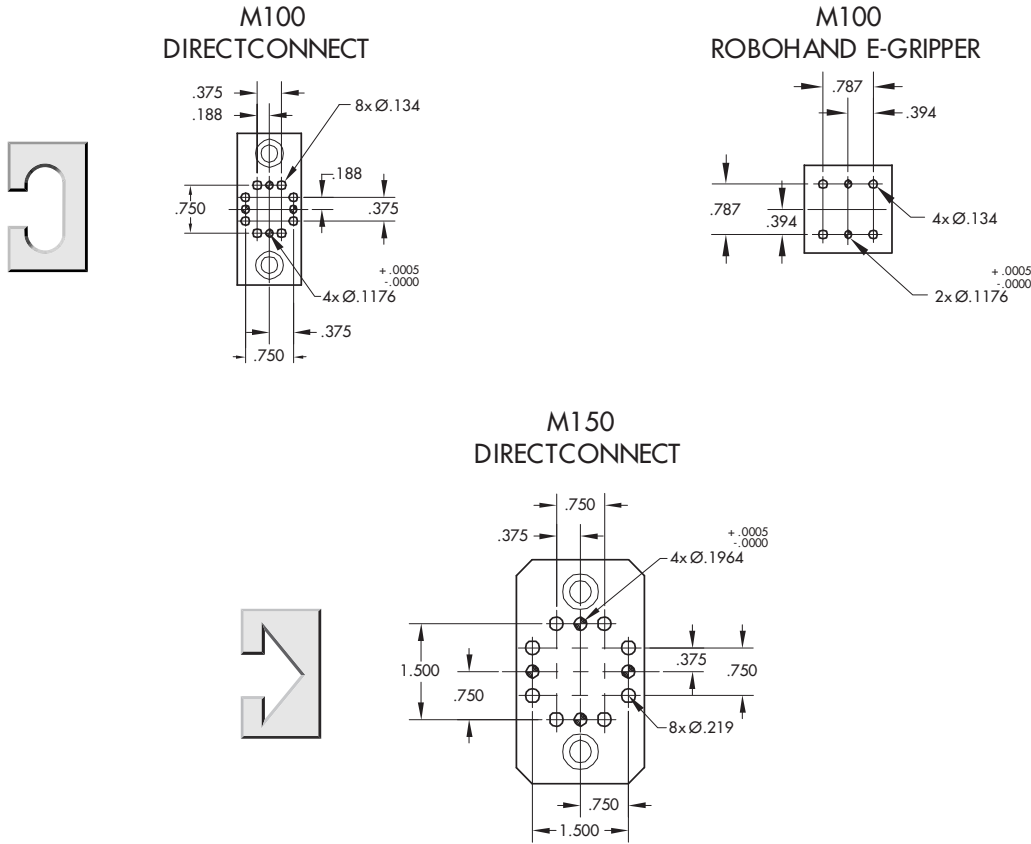

RoboHand DirectConnect Grippers & Rotaries

Consult the DE-STA-CO Automation Catalog or your local sales representative for information about these items.

Model	E-Gripper	DPDS/DPDL	DPG	DPP	DPW	DCT	DRF
M100	RPE-100M RPE-101M	DPDS-047M DPDS-056M DPDL-047M DPDL-056M	N/A	DPP-10M-06 DPP-10M-12 DPP-14M-15 DPP-14M-25	DPW-250M-1 DPW-250M-2	DCT-12M DCT-16M DCT-20M	N/A
M150	N/A	DPDS-088M DPDS-125M DPDL-088M DPDL-125M	DPG-10M-1 DPG-10M-2 DPG-10M-3 DPG-10M-4	DPP-20M-25 DPP-20M-28 DPP-28M-31 DPP-28M-50	DPW-375M-1 DPW-375M-2 DPW-500M-1 DPW-500M-2	DCT-25M	DRF/DRG-075M DRF/DRG-094M DRF/DRG-106M

Dimensions and technical information are subject to change without notice.

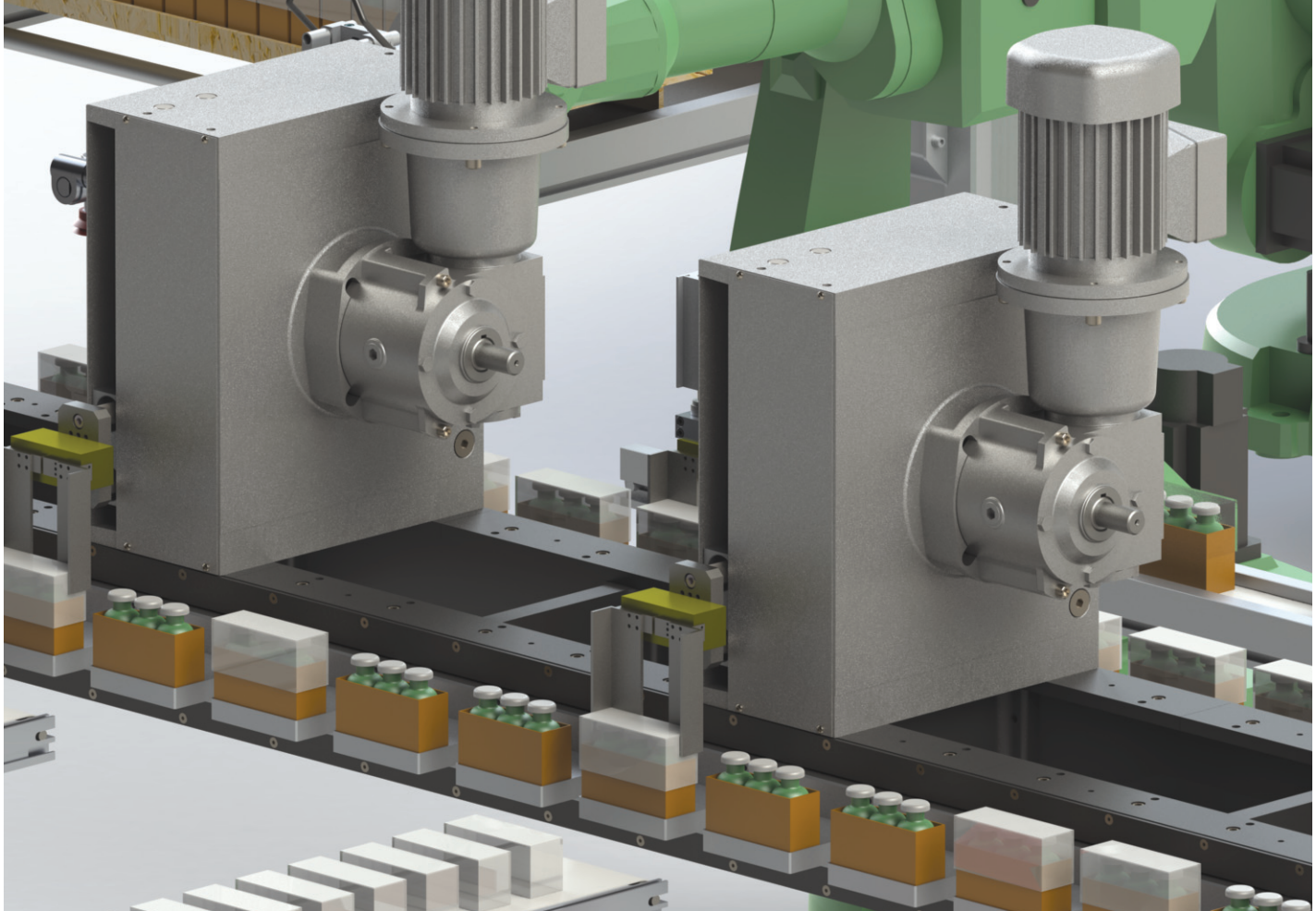

Indexer driving a conveyor and Linear Part Handlers

- Operation can be asynchronous (cycle on demand) – a single index followed by a variable dwell time, or the operation can be continuous.
- Index motion time is changed by changing the motion profile of the servo motor.
- Dwell time is variable. Single axis servo or multiple axis servo controllers can be used.
- More than 60 cycles per minute – maximum cycle rate can be determined by your application engineer.

Dimensions and technical information are subject to change without notice.



RPP Series Rotary Parts Handler



Features:

The **CAMCO RPP Cambot® Rotary Parts Handler** is designed for high precision and high capacity. This proven design can be used in a wide variety of industries including automotive, packaging and electronics among others. The RPP can be combined with other CAMCO products such as index drives and precision conveyors for a complete, automated system. The RPP is ideal for pick and place applications with features including:

- Rugged and precise cam operated mechanisms engineered for a minimum of 8000 hours of maintenance-free life.
- Hardened and ground cams drive both the lift and rotary axes.
- Preloaded precision cam followers eliminate backlash and ensure smooth movement.
- Preloaded taper roller bearings on the camshaft (Input Shaft).
- Four-point contact preloaded roller bearing on the rotary axis.
- All bearings are lubricated by an oil bath.
- One-piece lift arm.
- Ball bushings (recirculating-ball type) support the main lift shaft and turn the large output surface and ride on hardened shafts for stability and stiffness.
- Manufactured in a fully integrated application, design, manufacturing and inspection environment.

Table of Contents

How to Order	188
300RPP	190
500RPP	192
Timing Diagrams	194

Dimensions and technical information are subject to change without notice.



RPP Series How to Order

RPP Ordering Procedure

1. Model
2. Rotary Motion (degrees)
 - Oscillator or indexer
 - Oscillator: Home at X or Y
 - Indexer: CW or CCW index
3. Lift (inches)
4. Input Shaft: Side 1, Side 2 or Double Input (DI)
5. Mounting Position: 1-6

Reducer Ordering Procedure

1. Reducer Model, Ratio and Mounting Position
2. Motor Adaptor Model
3. Motor size

Input Shaft Configuration

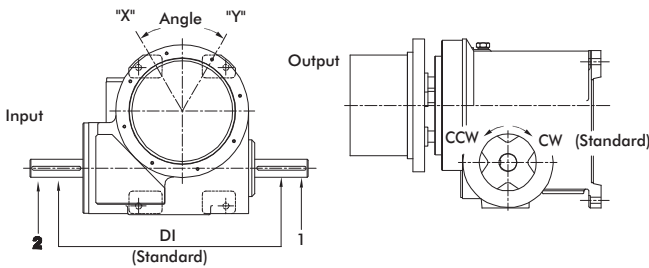

Standard Output Sequence

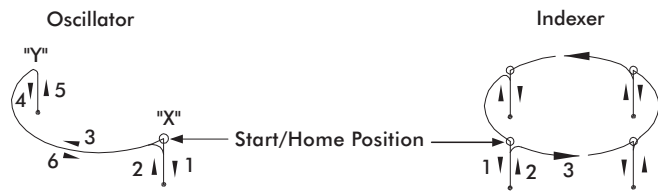

Dimensions and technical information are subject to change without notice.

Mounting Position

OVOI (output vertical, over input)	OVUI (output vertical, under input)	OHOI (output horizontal, over input)	OHUI (output horizontal, under input)	H-S1-UP (output horizontal, side 1 up)	H-S2-UP (output horizontal, side 2 up)
 1	 2	 3	 4	 5	 6

Gear Reducer Mounting Positions

		Mounting "A"		Mounting "B"	
		RH	LH	RH	LH
SIDE 1		 A	 B	 C	 D
SIDE 2		 E	 F	 G	 H
		Mounting "C"		Mounting "D"	
		RH	LH	RH	LH
SIDE 1		 J	 K	 L	 M
SIDE 2		 N	 P	 R	 S

Dimensions and technical information are subject to change without notice.

300RPP Standard Dimensions

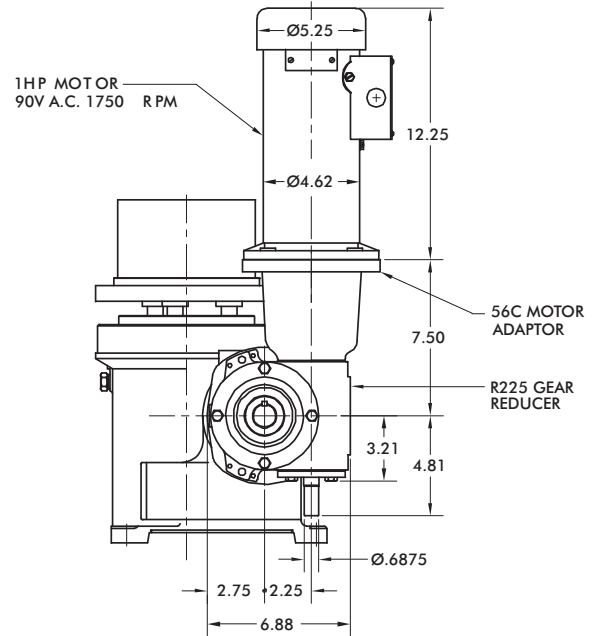
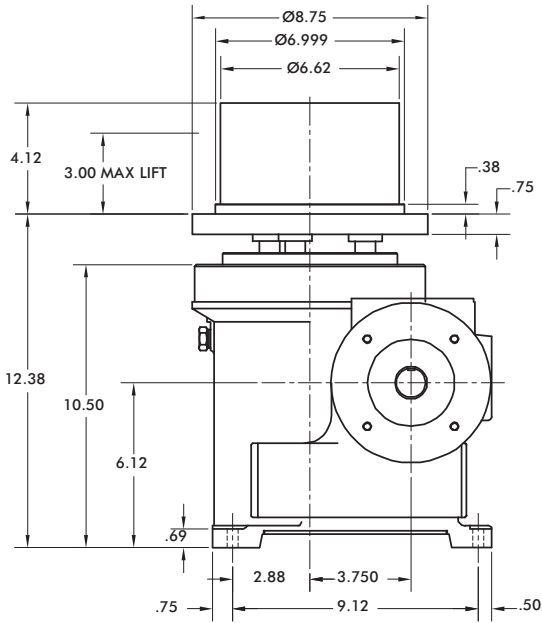
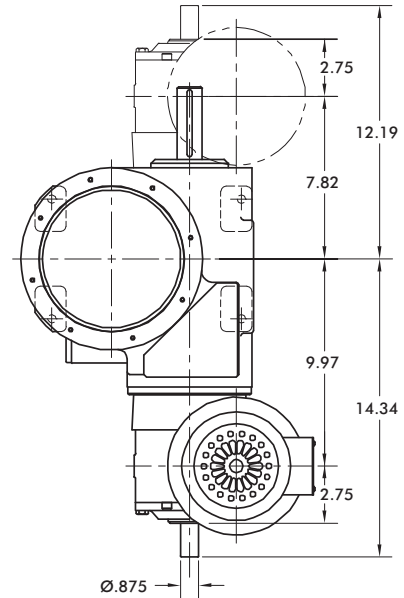
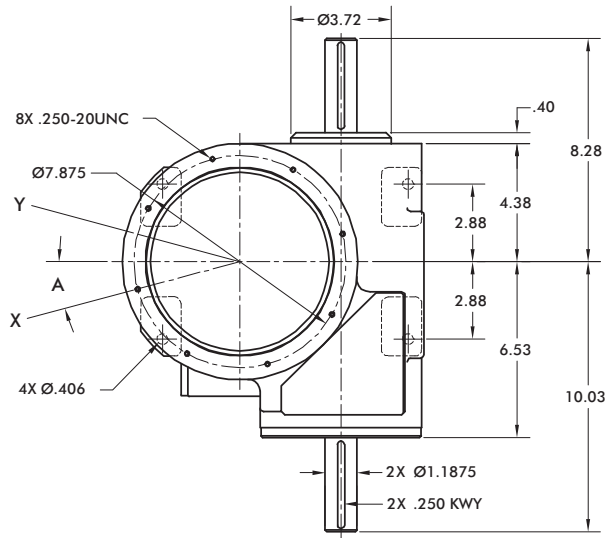

Dimensions and technical information are subject to change without notice.



300RPP Product Overview and Technical Specifications

Oscillating Motion				Indexing Motion			
Rotation	Angle A	Lift (in.)	Model	Rotation	Angle A	Lift (in.)	Model
120°	0°	1	300RPP120H24-1H24	180°	0°	1	300RPP2H24-1H24
		2	300RPP120H24-2H24			2	300RPP2H24-2H24
90°	15°	1	300RPP90H24-1H24			3	300RPP2H24-3H24
		2	300RPP90H24-2H24	120°	0°	1	300RPP3H24-1H24
		3	300RPP90H24-3H24			2	300RPP3H24-2H24
60°	0°	1	300RPP60H24-1H24	3	300RPP3H24-3H24		
		2	300RPP60H24-2H24	90°	0°	1	300RPP4H24-1H24
		3	300RPP60H24-3H24			2	300RPP4H24-2H24
45°	22.5°	1	300RPP45H24-1H24			3	300RPP4H24-3H24
		2	300RPP45H24-2H24	60°	0°	1	300RPP6H24-1H24
		3	300RPP45H24-3H24			2	300RPP6H24-2H24

Features

- Standard Indexing or Oscillating Motion
- R225 Reducer (Ratios from 5:1 to 60:1)
— 56C Motor Adapter and Coupling
- 1 hp AC Drive Package with Inverter Duty Motor and Inverter Drive (up to 60 cpm)

Optional Accessories

- 1 hp DC Motor
- Varipak DC Motor Control (up to 30 cpm)

Capacity:*

Maximum Mass 150 lbs
Maximum Inertia 1700 lb-in²

* Note: These values are for speeds of less than 30 rpm, the minimum cam time for rise and rotation, and are for reference only. Each application must be reviewed and approved by CAMCO Engineering.

Dimensions and technical information are subject to change without notice.

500RPP Standard Dimensions

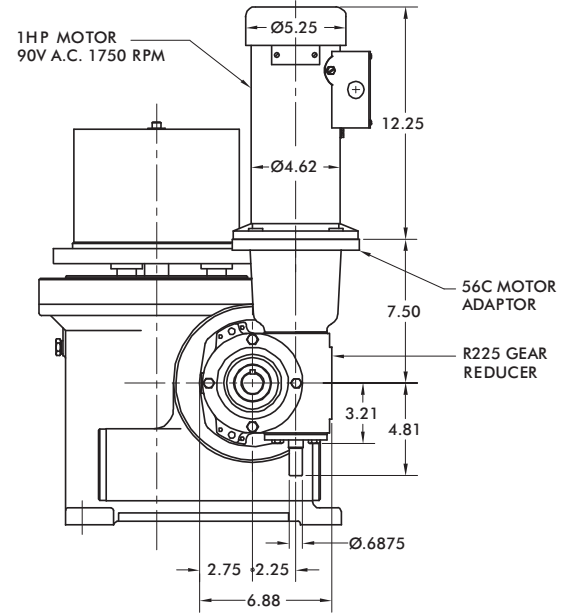
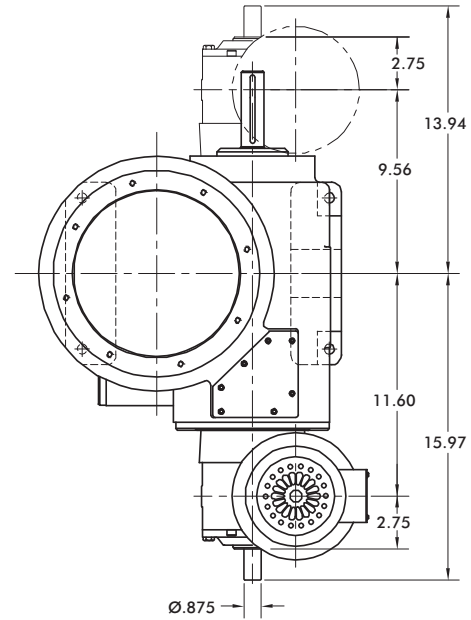
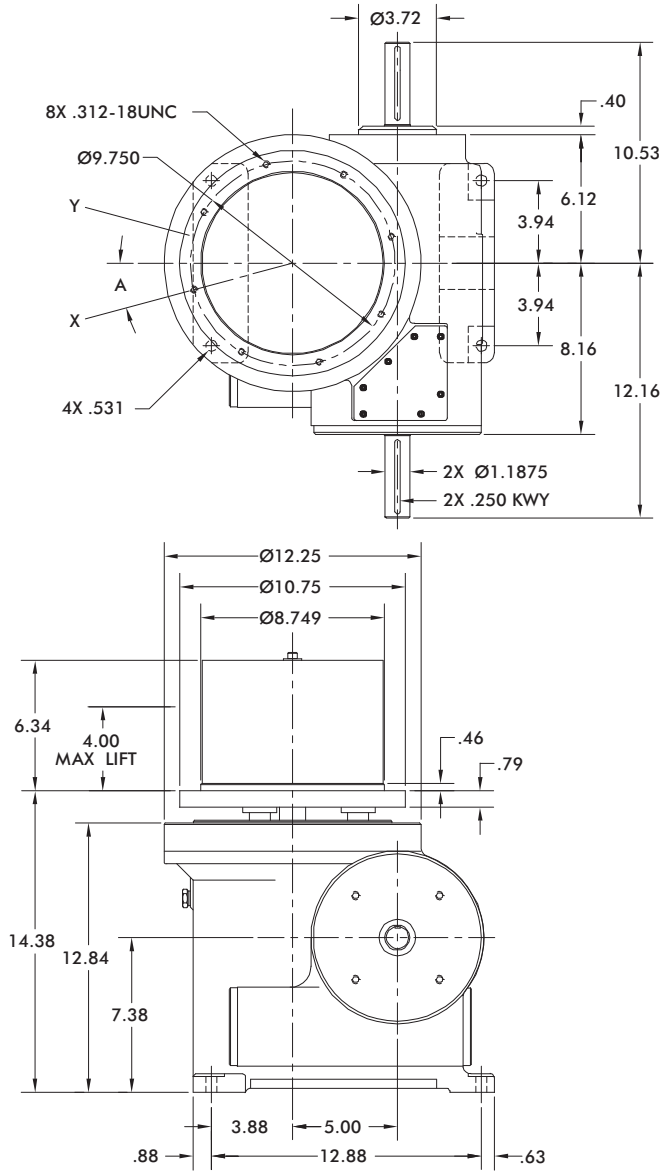

Dimensions and technical information are subject to change without notice.



500RPP Product Overview and Technical Specifications

Oscillating Motion				Indexing Motion			
Rotation	Angle A	Lift (in.)	Model	Rotation	Angle A	Lift (in.)	Model
180°	0°	2	500RPP2H32-2H32	120°	0°	2	500RPP120H32-2H32
		3	500RPP2H32-3H32			3	500RPP120H32-3H32
		4	500RPP2H32-4H32	90°	15°	2	500RPP90H32-2H32
2	500RPP3H32-2H32	3	500RPP90H32-3H32				
3	500RPP3H32-3H32	4	500RPP90H32-4H32				
120°	0°	4	500RPP3H32-4H32	60°	0°	2	500RPP60H32-2H32
		2	500RPP4H32-2H32			3	500RPP60H32-3H32
		3	500RPP4H32-3H32			4	500RPP60H32-4H32
90°	0°	4	500RPP4H32-4H32	45°	22.5°	2	500RPP45H32-2H32
		2	500RPP6H32-2H32			3	500RPP45H32-3H32
		3	500RPP6H32-3H32			4	500RPP45H32-4H32
60°	0°	4	500RPP6H32-4H32				

Features

- Standard Indexing or Oscillating Motion
- R225 Reducer (Ratios from 5:1 to 60:1)
— 56C Motor Adapter and Coupling
- 1 hp AC Drive Package with Inverter Duty Motor and Inverter Drive (up to 60 cpm)

Capacity:*

Maximum Mass 180 lbs
Maximum Inertia 3415 lb-in²

* Note: These values are for speeds of less than 30 rpm, the minimum cam time for rise and rotation, and are for reference only. Each application must be reviewed and approved by CAMCO Engineering.

Optional Accessories

- 1 hp DC Motor
- Varipak DC Motor Control (up to 30 cpm)

Dimensions and technical information are subject to change without notice.



Timing Diagram Oscillator

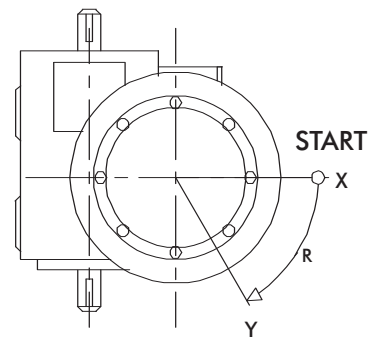
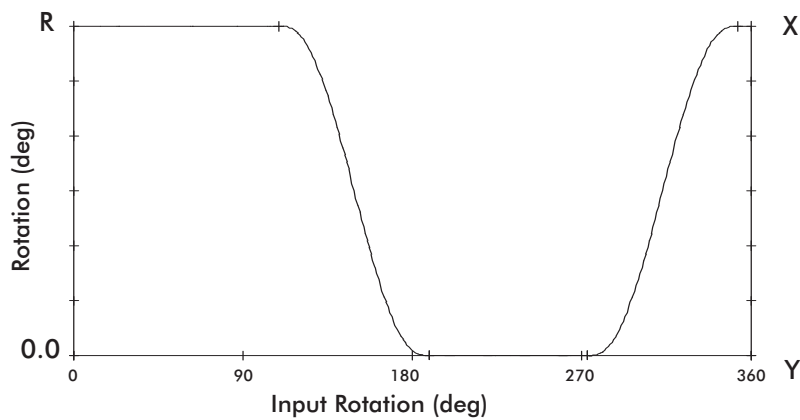
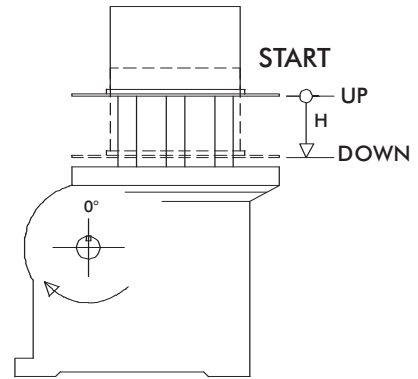
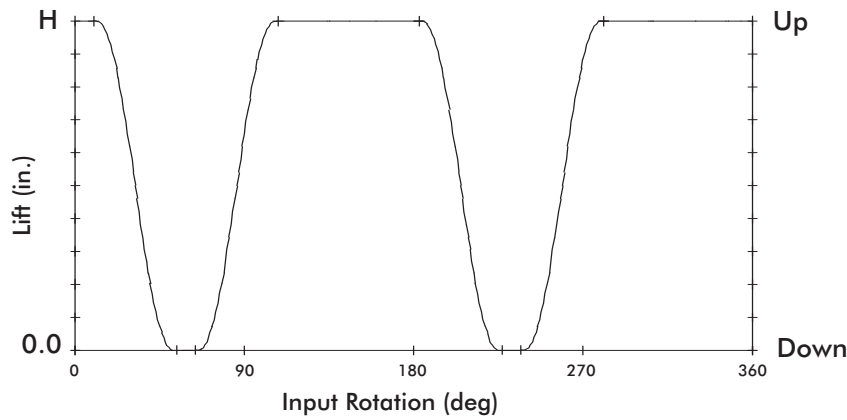

Motion Options

- Standard starting position (home) at time 0 is at maximum rise (up) and at the X rotary position.
- The standard sequence can be mirrored in either the lift, rotary or both:
 - The mirrored lift starts in the zero elevation or down position
 - The mirrored rotary motion starts at Y.
- Custom motion times are also available – consult your Sales Agent for more information.

Dimensions and technical information are subject to change without notice.

Timing Diagram Indexer

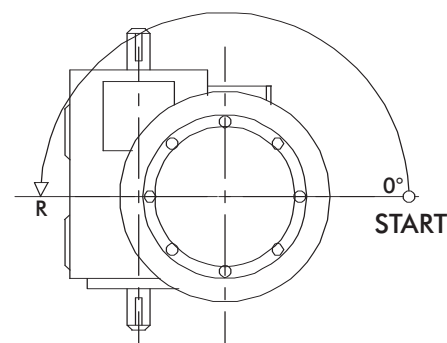
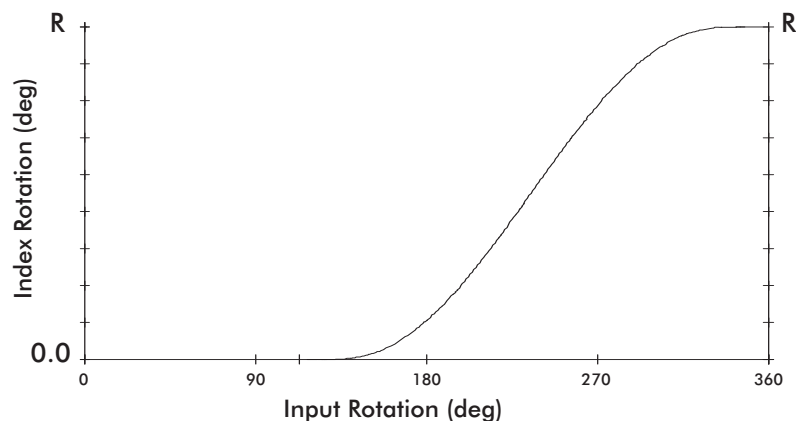
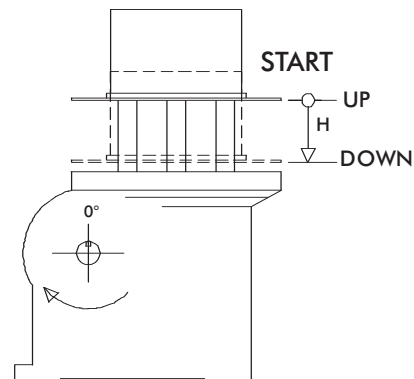
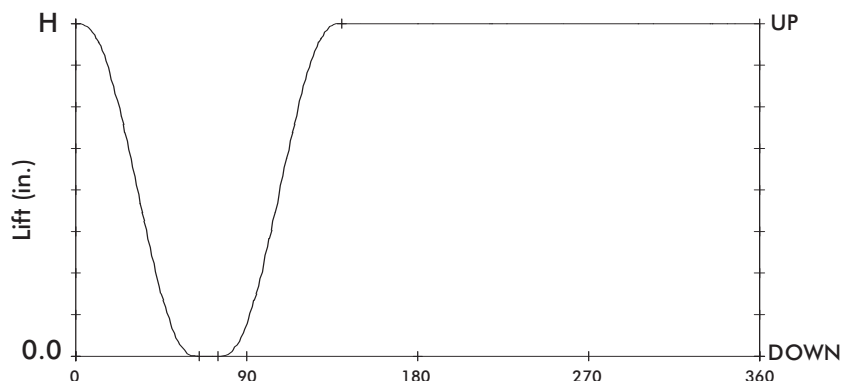

Motion Options

- Standard starting position (home) at time 0 is at maximum rise (up) and at the start of a counter-clockwise index (right-hand cam helix).
- The standard sequence can be mirrored in either the lift, rotary or both:
 - The mirrored lift starts in the zero elevation or down position
 - The mirrored rotary motion is a clockwise index (left-hand helix)
- Custom motion times are also available – consult your Sales Agent for more information.

Dimensions and technical information are subject to change without notice.



Features:

CAMCO Output Overload Clutches are designed to protect your indexing equipment from costly downtime due to overload or jam conditions by quickly disengaging the drive system.

- Easily Mounted to CAMCO index drives
- Single Position reset to maintain accuracy and machine timing
- Precision hardened and ground plungers and drive plate
- Overload Detector plate provides actuation for overload detector switch
- Variety of Models for all applications
- Standard & custom torque settings

Table of Contents

Overview	198
D	200
F	201
S	202
F	203
C.....	204
S-SD	205
FC-SD	206
C-SD	207

Dimensions and technical information are subject to change without notice.



Standard Output Overload Clutches Mounting Overview

CAMCO Output Overload Clutches quickly disengage the drive system in overload or jam conditions, protecting indexers from costly downtime. A variety of models are available in standard and custom torque settings. An overload detector plate provides actuation for the overload detector switch, and the clutch's single-position reset function maintains accuracy and machine timing.

- Standard and custom torque settings
- Single-position reset maintains timing, accuracy
- Range of models for all applications
- Rigid, backlash-free design



Indexer Type	Clutch Type
RDM RD	D (Flange Mounted Body)
Roller Gear (RGS / RGD) Parallel (P) Right Angle (RA)	F (Flange to Flange)
	FC (Flange to Shaft)
	FC-SD (Flange to Shaft, Shrink-Disk)
	S (Shaft to Flange)
	S-SD (Shaft to Flange, Shrink-Disk)
	C (Shaft to Shaft Mounting)
	C-SD (Shaft to Shaft, Shrink-Disk)

CAMCO Output Overload Clutches

D Clutch: Flange-Mounted Body

For CAMCO Index Drives with large dial mounting surfaces. The dial plate rests directly on the index drive output flange, providing stability and accuracy.

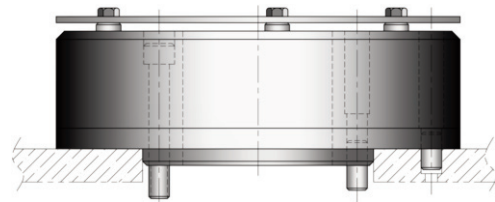

Dimensions and technical information are subject to change without notice.

CAMCO Output Overload Clutches

F Clutch: Flange-Mounted Body

F clutches are designed to mount a dial/sprocket/flanged component to a shaft output CAMCO index drive. These clutches will flange mount to the output shaft, providing a rigid, compact, and accurate connection with the driven member.

F clutches may be mounted in two positions, "A" (right, top) or "B" (right, bottom). Mounting "B" provides greater rigidity and overhung loading and should be used whenever high loads are exerted on driven members.

A Mounting

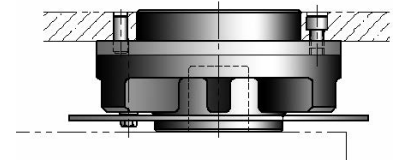

B Mounting

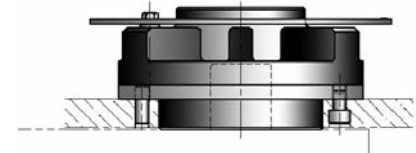

S & S-SD Clutch: Shaft to Flange

S clutches are designed to mount on CAMCO index drives without output flanges. The combination of key and clamped hub design provides a rigid and backlash-free connection.

S clutches may be mounted two positions, "A" or "B." Mounting "B" provides greater rigidity and overhung loading and should be used whenever high loads are exerted on driven members.

The S-SD clutch employs a shrink disk to connect to the shaft.

A Mounting

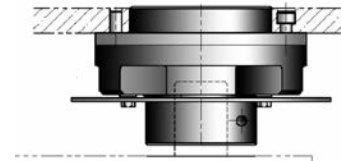

B Mounting

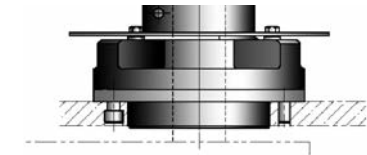

FC & FC-SD Clutch: Flange to Shaft

FC clutches are designed to mount on CAMCO index drives with flanged output shafts. These clutches will flange mount to the output shaft, providing a rigid, compact and accurate connection. The FC-SD clutch employs a shrink disk to connect to the shaft.

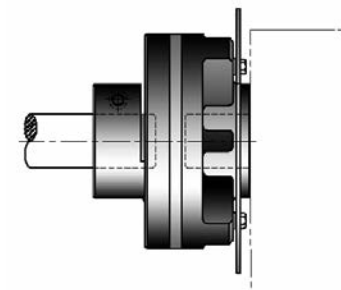

C Clutch: Shaft to Shaft

C clutches are designed to mount on CAMCO index drives without output flanges. These clutches are used whenever a positive connection is required between two shafts. The C-SD clutch employs shrink disks at both ends to connect to the shafts.

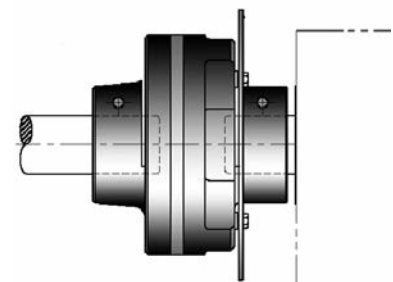

Dimensions and technical information are subject to change without notice.

D Type Flange-Mounted Body Product Overview, Technical Information

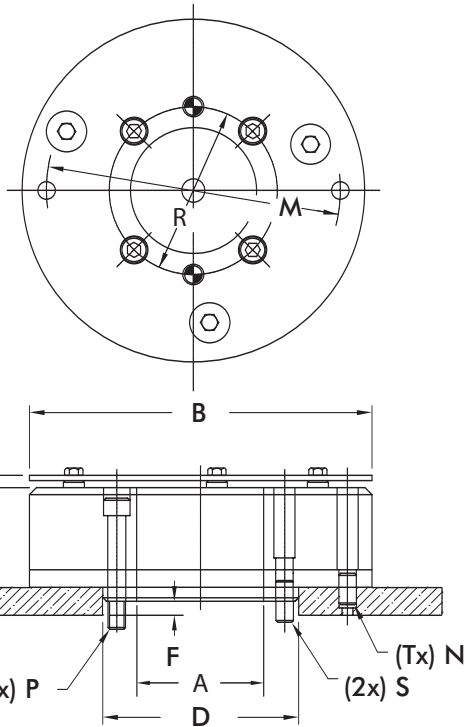

“D” Type clutches are designed to mount on CAMCO Index Drives with large dial mounting surfaces. The dial plate rests directly on the index drive output flange, providing stability and accuracy.

D Type Dimensions

Model	A	B	C	D	E	F	G	M	N	P	Q	R	S	T
2.8D	1.00	5.12	2.50	2.500	0.22	0.250	0.500	4.250	0.312	.312-18	4	2.00	0.31	2
4.0D	2.25	6.12	2.50	3.500	0.22	0.250	0.500	5.250	0.312	.312-18	4	3.00	0.31	2
7.8D	3.41	8.50	2.88	5.000	0.25	0.188	0.750	6.750	0.500	.500-20	4	4.25	0.50	2
18D	2.62	10.25	4.53	5.000	0.31	0.188	1.000	8.250	0.625	.500-20	4	4.25	0.50	2
31D	5.25	14.50	4.03	9.000	0.34	-	1.000	11.750	0.750	.500-20	6	8.25	0.50	4
32D	5.25	14.50	4.03	9.000	0.34	-	1.000	11.750	0.750	.500-13	6	8.25	0.50	4
33D (mm)	133	368	102	228.6	8.4***	-	25	298.5	20	M12	6	210	12	4
61D	7.25	18.38	5.40	11.000	0.34	-	1.250	16.000	0.750	.625-11	8	10.00	.625 (4)	4

* Dimension increases .06 during overload
 ** Dimension increases .09 during overload
 *** Dimension increases .12 during overload

D Type Specifications

Model	Internal Inertia	Torque Setting	Index Drive
2.8D	29	400 480 700 850 1100 1300 1800 2200 3100	425RD
4.0D	69	420 620 750 1150 1750 2950 4000	601RDM
7.8D	266	1400 1700 2600 3200 4200 5000 7200 10000	902RDM 663RAD 900RAD
18D	743	5000 7000 7800 10,000 13000 15000 20000 25000	900RAD
31D	2910	8500 13000 20000 31000	1200RAD
32D	2910	8500 13000 20000 31000	1305RDM
33D	2910	8500 13000 20000 25500	1100RDM
61D	4900	23000 36000 44000 50000 60000	1800RDM

Dimensions and technical information are subject to change without notice.



F Type Shaft to Flange Mounting Product Overview, Technical Information

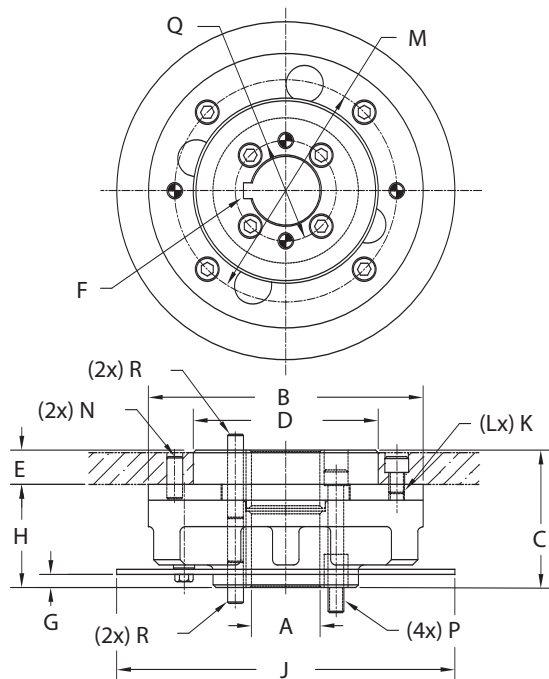

IMC "F" type clutches are designed to mount on IMC index drives. These clutches will flange mount to the output shaft, providing a rigid, compact, and accurate connection with the driven member.

F Type Dimensions

Model	A	B	C	D	E	F	G	H	J	K	L	M	N	P	Q	R
.39F	0.625	3.38	2.19	2.375	0.41	0.1875	.22†	1.78	4.75	Oct-32	4	2.875	0.25	Oct-32	1.25	0.25
2.3F	1.000*	5.12	2.78	3.5	0.56	0.25	.22†	2.22	6.5	5/16/24	4	4.25	0.312	5/16/24	2	0.31
6.0F	1.625	6.5	3.25	4.375	0.81	0.375	.31††	2.44	8	3/8/24	4	5.25	0.375	3/8/24	2.38	0.38
11F	2	8.5	3.72	5.75	0.81	0.5	.38††	2.91	10	3/8/24	4	6.75	0.5	3/8/24	3.25	0.5
25F	2.75	10.25	4.97	7.125	1.06	0.625	.38†††	3.91	12	1/2/13	6	8.25	0.625	1/2/20	4.25	0.63

* Also 1.250

† Dimension decreases .06 during overload

†† Dimension decreases .09 during overload

††† Dimension decreases .12 during overload

†††† Dimension decreases 1.5 mm during overload

F Type Specifications

Model	Internal Inertia	Torque Setting	Index Drive
.39F	5	160 210 270 320 390	250P
2.3F	32	400 600 700 850 1000 1300 1800 2000 230	387P 350RGS/RGD 400RA
6.0F	87	670 825 1100 1400 1700 2000 2300 2500 3000 3800 4000 5000 6000	512P 512RA
11F	340	2300 4000 6000 8500 11000	662P 662RA
25F	842	5000 7000 10000 13000 15000 20000 25000	900P

Dimensions and technical information are subject to change without notice.

S Type Shaft to Flange Mounting Product Overview, Technical Information

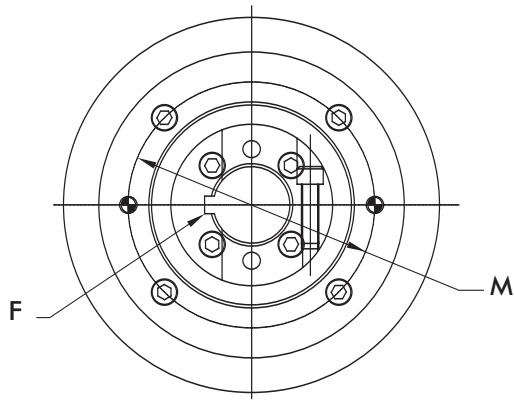

IMC "S" type clutches are designed to mount on CAMCO index drives without output flanges. The combination of key and clamped hub design provides a rigid and backlash-free connection.

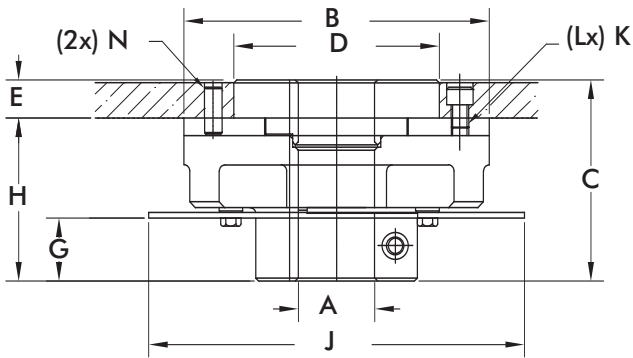

S Type Dimensions

Model	A	B	C	D	E	F	G	H	J	K	L	M	N
.39S	0.6250	3.38	2.63	2.375	0.40	0.187	.66†	2.22	4.75	10-32	4	2.88	0.250
2.3S	1.0000**	5.12	3.31	3.500	0.56	0.250	.75†	2.75	6.50	5/16-24	4	4.25	0.312
6.0S	1.6250	6.50	4.28	4.375	0.81	0.375	1.34††	3.47	8.00	3/8-24	4	5.25	0.375
11S	2.0000	8.50	5.00	5.750	0.81	0.500	1.69††	4.19	10.00	3/8-24	4	6.75	0.500
25S	2.5000	10.25	6.25	7.125	1.06	0.625	1.66†††	5.19	12.00	1/2-13	6	8.25	0.625

* Dimensions in millimeters

** Also 1.2500

† Dimension decreases .06 during overload

†† Dimension decreases .09 during overload

††† Dimension decreases .12 during overload

†††† Dimension decreases 1.5 mm during overload

S Type Specifications

Model	Internal Inertia	Torque Setting	Index Drive
.39S	5	160 210 270 320 390	250P
2.3S	31	400 600 700 850 1000 1300 1800 2000 2300	387P 350RGS/RGD 400RA
6.0S	83	670 825 1100 1400 1700 2000 2300 2500 3000 3800 4000 5000 6000	512P 512RA
11S	320	2300 4000 6000 8500 11000	500RGD/RGS 662RA 662P
25S	803	5000 7000 10000 13000 15000 20000 25000	700RGS

Dimensions and technical information are subject to change without notice.



FC Type Flange to Shaft Mounting Product Overview, Technical Information

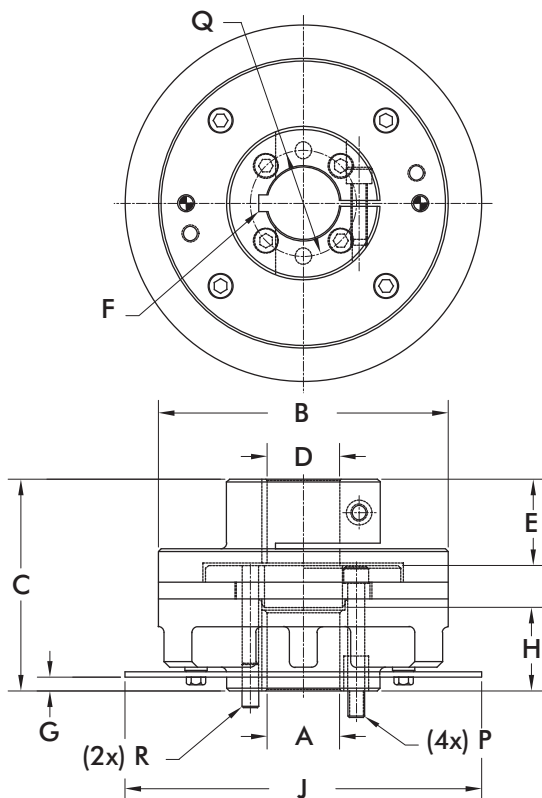

“FC” type clutches are designed to mount on CAMCO index drives. These clutches will flange mount to the output shaft, providing a rigid, compact and accurate connection.

FC Type Dimensions

Model	A	B	C	D	E	F	G	H	J	P	Q	R
.39FC	0.6250	3.38	3.03	0.625	1.06	0.187	.22†	1.41	4.75	10-32	1.25	0.25
2.3FC	1.0000**	5.12	3.81	1.000	1.28	0.250	.22†	1.75	6.50	5/16-24	2.00	0.31
6.0FC	1.6250	6.50	4.75	1.625	1.94	0.375	.31††	1.88	8.00	3/8-24	2.38	0.38
11FC	2.0000	8.50	5.72	2.000	2.38	0.500	.38††	2.25	10.00	3/8-24	3.25	0.38

* Dimensions in millimeters
 ** Also 1.2500

† Dimension decreases .06 during overload
 †† Dimension decreases .09 during overload
 ††† Dimension decreases .12 during overload
 †††† Dimension decreases 1.5 mm during overload

FC Type Specifications

Model	Internal Inertia	Torque Setting	Index Drive
.39FC	7	160 210 270 320 390	250P
2.3FC	43	400 600 700 850 1000 1300 1800 2000 2300	387P 350RGS/RGD 400RA
6.0FC	118	670 825 1100 1400 1700 2000 2300 2500 3000 3800 4000 5000 6000	512P 512RA
11FC	456	2300 4000 6000 8500 11000	662P 662RA

Dimensions and technical information are subject to change without notice.



For more information or to place an order call 1-800-645-5207 or visit www.camco.com or email camco@destaco.com

C Type Shaft to Shaft Mounting Product Overview, Technical Information

“C” type clutches are designed to mount on CAMCO index drives without output flanges. These clutches are used whenever a positive connection is required between two shafts.

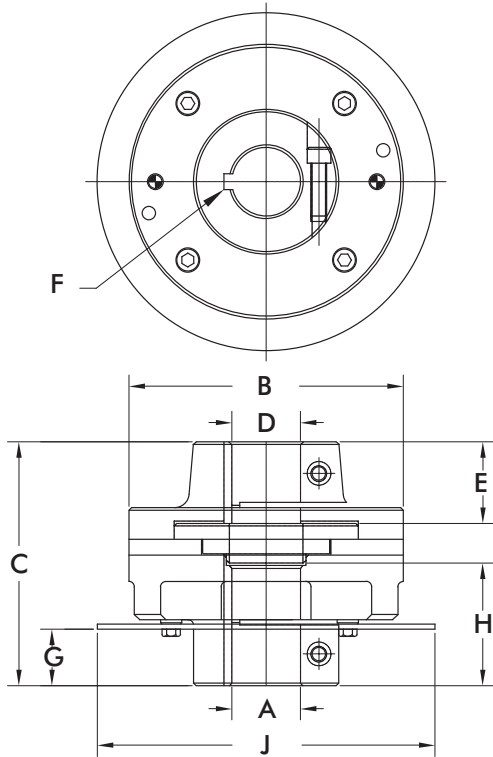

C Type Dimensions

Model	A	B	C	D	E	F	G	H	J	P	Q	R
.39C	0.6250	3.38	3.03	0.625	1.06	0.187	.22†	1.41	4.75	10-32	1.25	0.25
2.3C	1.0000**	5.12	3.81	1.000	1.28	0.250	.22†	1.75	6.50	5/16-24	2.00	0.31
6.0C	1.6250	6.50	4.75	1.625	1.94	0.375	.31††	1.88	8.00	3/8-24	2.38	0.38
11C	2.0000	8.50	5.72	2.000	2.38	0.500	.38††	2.25	10.00	3/8-24	3.25	0.38

* Dimensions in millimeters
 ** Also 1.2500

† Dimension decreases .06 during overload
 †† Dimension decreases .09 during overload
 ††† Dimension decreases .12 during overload
 †††† Dimension decreases 1.5 mm during overload

C Type Specifications

Model	Internal Inertia	Torque Setting	Index Drive
.39C	7	160 210 270 320 390	250P
2.3C	44	400 600 700 850 1000 1300 1800 2000 2300	387P 350RGS/RGD 400RA
6.0C	122	670 825 1100 1400 1700 2000 2300 2500 3000 3800 4000 5000 6000	512P 512RA
11C	476	2300 4000 6000 8500 11000	500RGD/RGS 662P

Dimensions and technical information are subject to change without notice.



S-SD Type Shaft to Flange, Shrink-Disk Mounting Product Overview, Technical Information

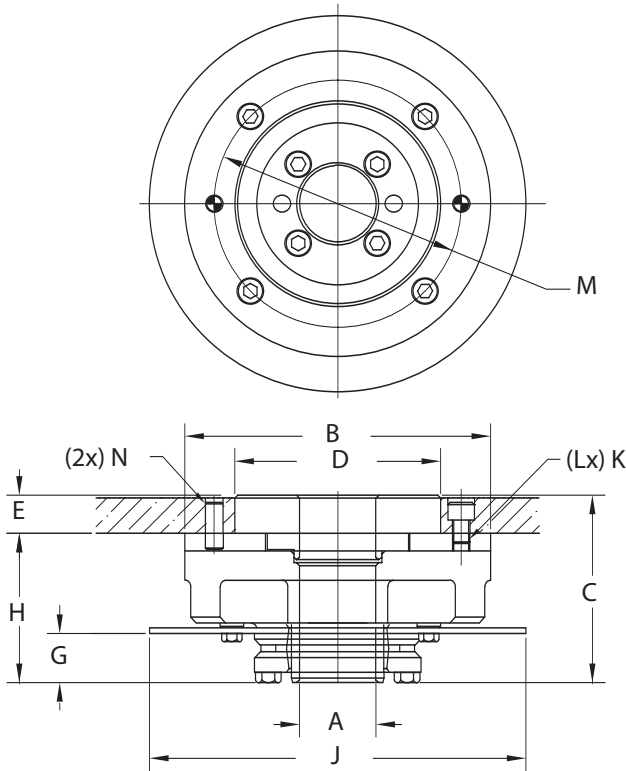

“S-SD” type clutches are designed to mount on CAMCO index drives without output flanges. The shrink disk design converts clamp loads from multiple high strength locking screws to radial gripping force through the use of circular wedges, providing the highest capacity mechanical interference connection available.

S-SD Type Dimensions

Model	A	B	C	D	E	F	G	H	J	K	L	N
.39-SD	0.6250	3.38	2.62	2.375	0.40	.66†	2.22	4.75	10-32	4	2.88	0.250
2.3-SD	1.0000	5.12	3.31	3.500	0.56	.75†	2.75	6.50	5/16-24	4	4.25	0.312
6.0-SD	1.6250	6.50	3.98	4.375	0.81	1.04††	3.17	8.00	3/8-24	4	5.25	0.375
11-SD	2.0000	8.50	4.38	5.750	0.82	1.06††	3.56	10.00	3/8-24	4	6.75	0.500

* Dimensions in millimeters

† Dimension decreases .06 during overload

†† Dimension decreases .09 during overload

††† Dimension decreases .12 during overload

†††† Dimension decreases 1.5 mm during overload

S-SD Type Specifications

Model	Internal Inertia	Torque Setting	Index Drive
.39-SD	5	160 210 270 320 390	250P
2.3-SD	32	400 600 700 850 1000 1300 1800 2000 2300	387P 350RGS/RGD 400RA
6.0-SD	87	670 825 1100 1400 1700 2000 2300 2500 3000 3800 4000 5000 6000	512P 512RA
11-SD	340	2300 4000 6000 8500 11000	500RGD/RGS 662P

Dimensions and technical information are subject to change without notice.

FC-SD Type Flange to Shaft, Shrink-Disk Mounting Product Overview, Technical Information

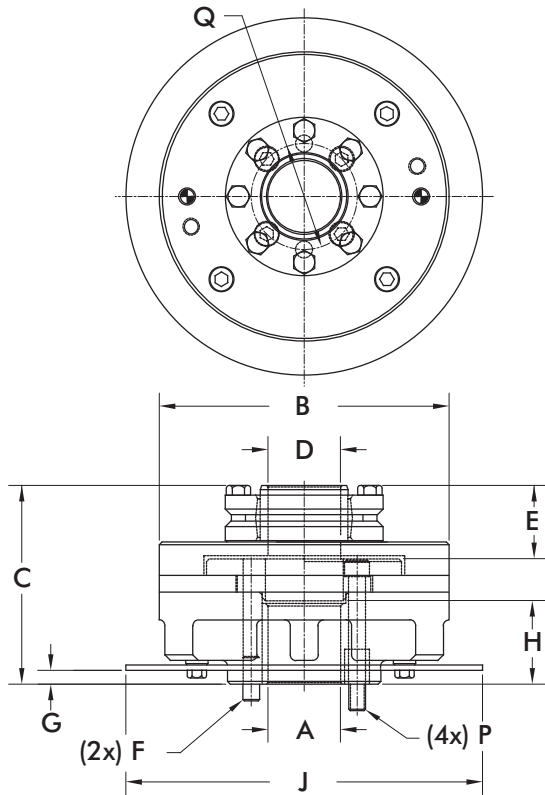

“FC-SD” type clutches are designed to mount on CAMCO index drives with output flanges. The shrink disk design converts clamp loads from multiple high strength locking screws to radial gripping force through the use of circular wedges, providing the highest capacity mechanical interference connection available.

FC-SD Type Dimensions

Model	A	B	C	D	E	F	G	H	J	P	Q
.39FC-SD	0.6250	3.38	3.00	0.625	1.03	0.25	.22†	1.41	4.75	10-32	1.25
2.3FC-SD	1.0000	5.12	3.81	1.000	1.27	0.31	.22†	1.75	6.50	5/16-24	2.00
6.0FC-SD	1.6250	6.50	4.46	1.625	1.64	0.38	.31††	1.88	8.00	3/8-24	2.38
11FC-SD	2.0000	8.50	5.06	2.000	1.75	0.38	.38††	2.25	10.00	3/8-24	3.25

* Dimensions in millimeters

† Dimension decreases .06 during overload

†† Dimension decreases .09 during overload

††† Dimension decreases .12 during overload

†††† Dimension decreases 1.5 mm during overload

FC-SD Type Specifications

Model	Internal Inertia	Torque Setting	Index Drive
.39FC-SD	7	160 210 270 320 390	250P
2.3FC-SD	34	400 600 700 850 1000 1300 1800 2000 2300	387P 350RGS/RGD 400RA
6.0FC-SD	118	670 825 1100 1400 1700 2000 2300 2500 3000 3800 4000 5000 6000	512P 512RA
11FC-SD	456	2300 4000 6000 8500 11000	500RGD/RGS 662P 662RA

Dimensions and technical information are subject to change without notice.



C-SD Type Shaft to Shaft, Shrink-Disk Mounting Product Overview, Technical Information

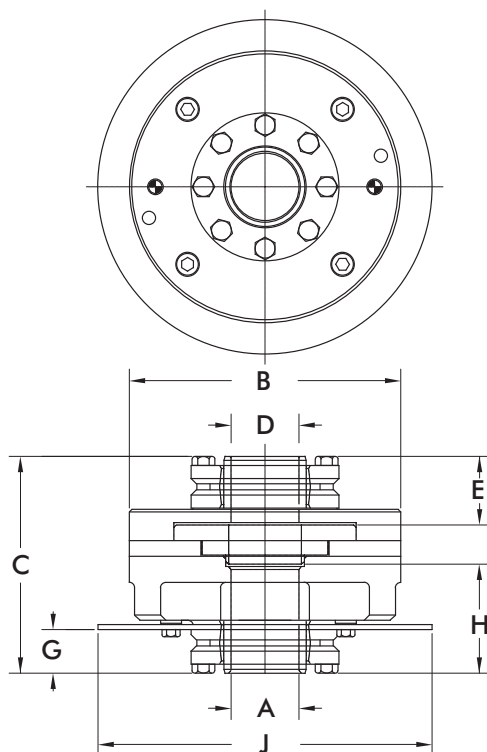

“C-SD” type clutches are designed to mount on CAMCO index drives without output flanges. The shrink disk design converts clamp loads from multiple high strength locking screws to radial gripping force through the use of circular wedges, providing the highest capacity mechanical interference connection available.

C-SD Type Dimensions

Model	A	B	C	D	E	G	H	J
.39C-SD	0.6250	3.38	3.44	0.625	1.03	.66†	1.84	4.75
2.3C-SD	1.0000	5.12	4.34	1.000	1.28	.75†	2.28	6.50
6.0C-SD	1.6250	6.50	5.19	1.625	1.64	1.04††	2.61	8.00
11C-SD	2.0000	8.50	5.75	2.000	1.75	1.06††	2.93	10.00

* Dimensions in millimeters

† Dimension decreases .06 during overload
 †† Dimension decreases .09 during overload
 ††† Dimension decreases .12 during overload
 †††† Dimension decreases 1.5 mm during overload

C-SD Type Specifications

Model	Internal Inertia	Torque Setting	Index Drive
.39C-SD	7	160 210 270 320 390	250P
2.3C-SD	44	400 600 700 850 1000 1300 1800 2000 2300	387P 350RGS/RGD 400RA
6.0C-SD	122	670 825 1100 1400 1700 2000 2300 2500 3000 3800 4000 5000 6000	512P 512RA
11C-SD	476	2300 4000 6000 8500 11000	500RGD/RGS 662P 662RA

Dimensions and technical information are subject to change without notice.

Custom Cams



CAMCO Custom Cams serve as an economical alternative to "in house" cam design, engineering and manufacturing. Backed by over 100 years of experience, we offer cams in a comprehensive range of configurations, tolerances and materials.





Our designers employ the most advanced computer technology available for detailed kinematic studies and dynamic analysis. In addition to common dimensional inspection, we perform computerized contour measurements with sophisticated, unique inspection equipment in both 2D and 3D.

Our commitment to applied engineering allows us to respond quickly to complicated manufacturing issues with specialized solutions that are precise, economical and engineered to your exacting specifications. Alternative materials, milling, and grinding techniques are explored to provide the best solution for your application at the most economical price.

To assist in your in-house cam design, you can download Clyde H. Moon's "Cam Design Manual for Engineers, Designers, and Draftsman" from the DE-STA-CO website, www.destaco.com.

Dimensions and technical information are subject to change without notice.

Custom Cams are available in a variety of styles:

<p>Plate Cams Popular, economical design used in low speed applications.</p>	
<p>Globoidal Cams Complex, tapered rib globoidal cams, commonly known as roller gear cams, are the heart of IMC's indexers. Controlled follower preloads increase follower life, speeds and accuracy for the ultimate solution in motion control.</p>	
<p>Face-Grooved Cams Medium speed cams using a groove slightly larger than the follower diameter providing minimal running clearance and reduced backlash.</p>	
<p>Conjugate Cams Dual cams controlling preloaded followers which provide higher speed capabilities and better accuracy.</p>	
<p>Barrel Cams Cylindrical cams which can be provided as an end cam, grooved type with minimal follower clearance or as a ribbed type utilizing preloaded followers for increased life and accuracy.</p>	

Dimensions and technical information are subject to change without notice.

**Product/Application Overview** 4**Engineering Overview** 9**RDM**

80RDM 42

601RDM 44

902RDM 46

1100RDM 48

1305RDM 50

1800RDM 52

RD

425RD 58

800RD 60

1301RD 62

1801RD 64

E-Series

750E 70

950E 72

1150E 74

1550E 76

Ring Drive

750RNG 82

1100RNG 84

1550RNG 86

Servo

115RSD 88

DX 91

RGD/RGS

40RGD/S 120

50RGD/S 122

70RGD/S 124

80RGD/S 126

110RGD/S 128

350RGD/S 130

500RGD/S 132

600RGD/S 134

Parallel

250P 140

387P 142

512P 144

662P 146

RA

400RA 152

512RA 154

662RA 156

RiteLink Conveyors

75mm, 115mm, 150mm 158

Modular Conveyors

3.0 Inch 162

4.5 Inch 164

6.0 Inch 168

Heavy Duty Conveyors

6.0 Inch HD 174

9.0 Inch HD 176

12.0 Inch HD 178

Parts Handlers

M100/150 LPP 184

300RPP 190

500RPP 192

Overload Clutches

D 200

S 201

FC 202

C 203

F 204

S-SD 205

FC-SD 206

C-SD 207

Custom Applications

Custom Cams 208

EACH DAY, DE-STA-CO PROVIDES CUSTOMERS WITH A COMPLETE RANGE OF WORKHOLDING AND AUTOMATION PRODUCTS AND SERVICES that reduce costs, minimize waste and eliminate bottlenecks. As a global supplier, we have extensive experience in bringing optimal solutions to customers of all needs and sizes. When you partner with DE-STA-CO, you put a world of resources at your fingertips.



MODULAR AUTOMATION

Our full continuum of products provides an extremely flexible approach to automation. Through DE-STA-CO, you receive a solution that is specifically tailored to meet the needs and demands of your operations



TRAINING

Providing true solutions requires more than just standard-setting products. DE-STA-CO provides customers with a variety of optional training opportunities, including online, onsite and customized training programs.



GLOBAL WEB RESOURCE

In addition to working closely with customers on a face-to-face basis, we provide a wealth of accessible, user-friendly material through our website, www.destaco.com. DE-STA-CO's website contains the comprehensive product information you would expect, as well as intuitive tools designed to provide instant customer support.



3D CAD & CONFIGURATOR

DE-STA-CO supports a wide variety of CAD programs, ranging from AutoCAD to SolidWorks. Our innovative online digital catalog features a 3D CAD library that allows engineers to configure individual 3D models from DE-STA-CO's extensive product lines.

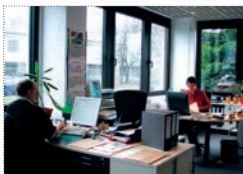

CUSTOMER SUPPORT

DE-STA-CO provides support to customers available via fax, email or telephone. Our highly trained customer service staff work diligently to address any and all questions you might have.



TECHNICAL SUPPORT

DE-STA-CO customers receive technical support from our own expert engineers. These highly trained employees work hand-in-hand with you to develop and implement the best possible solutions for your operations.

PRODUCT WARRANTY

All DE-STA-CO Industrial Products are thoroughly inspected and tested. We fully guarantee all materials and workmanship to be free of defects. Any product that is found to be defective in design, material or workmanship in the course of its normal use will be promptly replaced.

This Warranty does not apply to any product where the failure is a result of misapplication or abuse, nor is there any Warranty expressed or implied as to the merchantability or fitness for a particular purpose of the product and any warranty is limited to the above express warranty.

This Warranty is null and void if the product is repaired, modified or altered in any way. DE-STA-CO is not liable for labor, special, direct, incidental, or consequential damages and under no circumstances any charges in excess of the invoice amount of the product proven to be defective.



A DOVER COMPANY

Workholding

- Widest variety of workholding products
- High durability and reliability
- Flexible solutions for all applications
- Custom products for unique requirements

Automation

- Broad range of engineered automation products
- Complementary products for modular integration
- Unmatched accuracy, reliability and performance
- Unparalleled global sales, service and engineering support

GLOBAL LOCATIONS

NORTH AMERICA

DE-STA-CO Headquarters
 Auburn Hills, Michigan
 Tel: 1.248.836.6700
 Toll Free: 1.888.DESTACO
 Marketing: marketing@destaco.com
 Customer Service: customerservice@destaco.com

Charlevoix, Michigan
 Tel: 1.888.DESTACO
 Customer Service: customerservice@destaco.com

Wheeling, Illinois
 Tel: 1.800.645.5207
 Customer Service: camco@destaco.com

Red Wing, Minnesota (Central Research Laboratories)
 Tel: 651.385.2142
 Customer Service: sales@centres.com

SOUTH AMERICA

Brazil
 Tel: 0800-124070
 Customer Service: samerica@destaco.com

ASIA

Thailand
 Tel: +66-2-326-0812
 Customer Service: info@destaco.com

China
 Tel: +86-21-6081-2888
 Customer Service: china@destaco.com

India
 Tel: +91-80-41123421-426
 Customer Service: india@destaco.com

EUROPE

Germany
 Tel: +49-6171-705-0
 Customer Service: europa@destaco.com

France
 Tel: +33-1-3996-5000
 Customer Service: france@destaco.com

UK
 Tel: +44-1902-797980
 Customer Service: uk@destaco.com

Spain
 Tel: +34-936361680
 Customer Service: spain@destaco.com

Netherlands
 Tel: +31-297285332
 Customer Service: benelux@destaco.com



A DOVER COMPANY

CAMCO Products

1444 South Wolf Road
 Wheeling, IL 60090
 phone: 1.847.494.5200
 fax: 1.847.459.3064
 Email: camco@destaco.com
 Web: www.destaco.com



© Copyright, 2012 DE-STA-CO. All rights for layout, photos and text rest with the publisher DE-STA-CO. All photomechanical or other reproductions only with our express permission. All sales are based on our terms and conditions of sale, delivery and payment.

DSC_PI-C_1212_US_XXK